

BHTS ZZ FB 375°

BECO PLUS

NEW
2017

Extreme Temperature Bearings



6200 SERIE

Designation	Bore (B)	Diam (D)	Width (W)	Speed, RPM	Static Load, kN at 375°C	Static Load, kN at 20°C
6200 BHTS ZZ FB 375° BECO PLUS	10	30	9	90	1,79	2,60
6201 BHTS ZZ FB 375° BECO PLUS	12	32	10	85	2,14	3,10
6202 BHTS ZZ FB 375° BECO PLUS	15	35	11	80	2,59	3,75
6203 BHTS ZZ FB 375° BECO PLUS	17	40	12	75	3,28	4,75
6204 BHTS ZZ FB 375° BECO PLUS	20	47	14	70	4,52	6,55
6205 BHTS ZZ FB 375° BECO PLUS	25	52	15	65	5,52	8,00
6206 BHTS ZZ FB 375° BECO PLUS	30	62	16	60	7,72	11,2
6207 BHTS ZZ FB 375° BECO PLUS	35	72	17	55	10,55	15,3
6208 BHTS ZZ FB 375° BECO PLUS	40	80	18	50	12,41	18,0

6300 SERIE

Designation	Bore (B)	Diam (D)	Width (W)	Speed, RPM	Static Load, kN at 375°C	Static Load, kN at 20°C
6300 BHTS ZZ FB 375° BECO PLUS	10	35	11	90	2,38	3,45
6301 BHTS ZZ FB 375° BECO PLUS	12	37	12	85	2,86	4,15
6302 BHTS ZZ FB 375° BECO PLUS	15	42	13	80	3,72	5,40
6303 BHTS ZZ FB 375° BECO PLUS	17	47	14	75	4,52	6,55
6304 BHTS ZZ FB 375° BECO PLUS	20	52	15	70	5,86	8,50
6305 BHTS ZZ FB 375° BECO PLUS	25	62	17	65	11,24	11,4
6306 BHTS ZZ FB 375° BECO PLUS	30	72	19	60	13,10	16,3
6307 BHTS ZZ FB 375° BECO PLUS	35	80	21	55	16,53	19,0
6308 BHTS ZZ FB 375° BECO PLUS	40	90	23	50	17,20	25,0
6309 BHTS ZZ FB 375° BECO PLUS	45	100	25	45	22,00	32,0
6310 BHTS ZZ FB 375° BECO PLUS	50	110	27	40	26,20	38,0

AVAILABLE ON REQUEST:

6000 SERIE

Designation	Bore (B)	Diam (D)	Width (W)	Speed, RPM	Static Load, kN at 375°C	Static Load, kN at 20°C
6000 BHTS ZZ FB 375° BECO PLUS	10	26	8	90	1,35	1,96
6001 BHTS ZZ FB 375° BECO PLUS	12	28	8	85	1,63	2,36
6002 BHTS ZZ FB 375° BECO PLUS	15	32	9	80	1,97	2,85
6003 BHTS ZZ FB 375° BECO PLUS	17	35	10	75	2,24	3,25
6004 BHTS ZZ FB 375° BECO PLUS	20	42	12	70	3,45	5,00
6005 BHTS ZZ FB 375° BECO PLUS	25	47	12	65	4,03	5,85
6006 BHTS ZZ FB 375° BECO PLUS	30	55	13	60	5,52	8,00
6007 BHTS ZZ FB 375° BECO PLUS	35	62	14	55	7,17	10,4
6008 BHTS ZZ FB 375° BECO PLUS	40	68	15	50	8,14	11,8
6009 BHTS ZZ FB 375° BECO PLUS	45	75	16	45	9,86	14,3
6010 BHTS ZZ FB 375° BECO PLUS	50	80	16	40	10,76	15,6

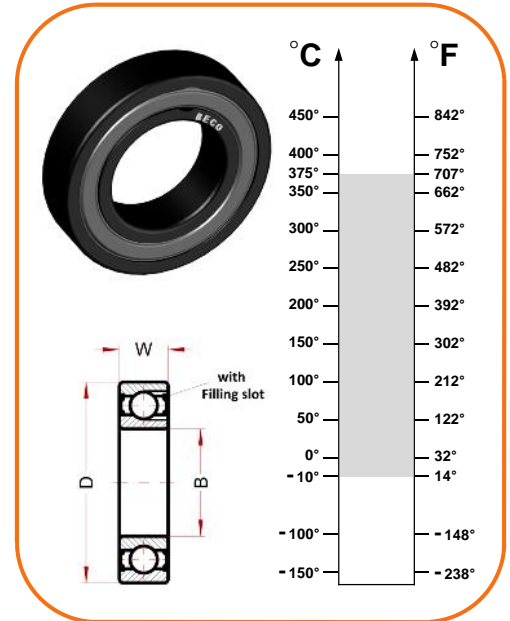

Technical characteristics:

- Bearing material: steel AISI 52100 (Chrome) stabilized to the application
- Treatment of manganese phosphate coating on all steel parts of the bearing
- Radial Clearance 4xC5
- Shields type ZZ
- Lubricated for life with BECO grease-compound for temperature up to 375°C

Fields of application:

- Paint Ovens
- Steel industry
- Furnaces for Ceramic Industry
- Trolley Industry, Trolley for Brick Kilns Industry

BECCO

12100 Cuneo - Italy

phone: 0039 0171 66883

fax: 0039 0171 648913

www.becoitalia.it