

BHTS ZZ C4 200°

High Temperature Bearings



6000 SERIE

Designation	Bore (B)	Diam (D)	Width (W)	Speed, RPM	Static Load, kN at 200°C	Static Load, kN at 20°C
6000 BHTS ZZ C4 200°	10	26	8	6000	1,76	1,96
6001 BHTS ZZ C4 200°	12	28	8	5800	2,10	2,36
6002 BHTS ZZ C4 200°	15	32	9	5600	2,50	2,85
6003 BHTS ZZ C4 200°	17	35	10	5400	2,90	3,25
6004 BHTS ZZ C4 200°	20	42	12	5200	4,50	5,00
6005 BHTS ZZ C4 200°	25	47	12	4800	5,20	5,85
6006 BHTS ZZ C4 200°	30	55	13	4400	7,20	8,00
6007 BHTS ZZ C4 200°	35	62	14	4000	9,30	10,4
6008 BHTS ZZ C4 200°	40	68	15	3600	10,6	11,8
6009 BHTS ZZ C4 200°	45	75	16	3200	12,8	14,3
6010 BHTS ZZ C4 200°	50	80	16	2800	14,0	15,6
6011 BHTS ZZ C4 200°	55	90	18	2400	19,0	21,2
6012 BHTS ZZ C4 200°	60	95	18	2000	20,8	23,2
6013 BHTS ZZ C4 200°	65	100	18	1800	22,5	25,0
6014 BHTS ZZ C4 200°	70	110	20	1600	28,3	31,5
6015 BHTS ZZ C4 200°	75	115	20	1400	30,6	34,0
6016 BHTS ZZ C4 200°	80	125	22	1200	36,0	40,0
6017 BHTS ZZ C4 200°	85	130	22	1000	38,7	42,9
6018 BHTS ZZ C4 200°	90	140	24	900	45,0	49,9
6019 BHTS ZZ C4 200°	95	145	24	800	48,6	53,9
6020 BHTS ZZ C4 200°	100	150	24	700	48,6	53,9

6200 SERIE

Designation	Bore (B)	Diam (D)	Width (W)	Speed, RPM	Static Load, kN at 200°C	Static Load, kN at 20°C
6200 BHTS ZZ C4 200°	10	30	9	5800	2,30	2,60
6201 BHTS ZZ C4 200°	12	32	10	5600	2,80	3,10
6202 BHTS ZZ C4 200°	15	35	11	5400	3,30	3,75
6203 BHTS ZZ C4 200°	17	40	12	5200	4,20	4,75
6204 BHTS ZZ C4 200°	20	47	14	4800	5,90	6,55
6205 BHTS ZZ C4 200°	25	52	15	4400	7,20	8,00
6206 BHTS ZZ C4 200°	30	62	16	4000	10,0	11,2
6207 BHTS ZZ C4 200°	35	72	17	3600	13,7	15,3
6208 BHTS ZZ C4 200°	40	80	18	3200	16,2	18,0
6209 BHTS ZZ C4 200°	45	85	19	2800	18,3	20,4
6210 BHTS ZZ C4 200°	50	90	20	2400	21,6	24,0
6211 BHTS ZZ C4 200°	55	100	21	2000	26,1	29,0
6212 BHTS ZZ C4 200°	60	110	22	1800	32,4	36,0
6213 BHTS ZZ C4 200°	65	120	23	1600	37,3	41,5
6214 BHTS ZZ C4 200°	70	125	24	1400	39,6	44,0
6215 BHTS ZZ C4 200°	75	130	25	1200	44,1	49,0
6216 BHTS ZZ C4 200°	80	140	26	1000	49,5	55,0
6217 BHTS ZZ C4 200°	85	150	28	900	57,6	64,0
6218 BHTS ZZ C4 200°	90	160	30	800	66,1	73,5
6219 BHTS ZZ C4 200°	95	170	32	700	73,3	81,5
6220 BHTS ZZ C4 200°	100	180	34	600	83,7	93,0

6300 SERIE

Designation	Bore (B)	Diam (D)	Width (W)	Speed, RPM	Static Load, kN at 200°C	Static Load, kN at 20°C
6300 BHTS ZZ C4 200°	10	35	11	5600	3,1	3,45
6301 BHTS ZZ C4 200°	12	37	12	5400	3,7	4,15
6302 BHTS ZZ C4 200°	15	42	13	5200	4,8	5,40
6303 BHTS ZZ C4 200°	17	47	14	4800	5,8	6,55
6304 BHTS ZZ C4 200°	20	52	15	4400	7,6	8,50
6305 BHTS ZZ C4 200°	25	62	17	4000	10,2	11,4
6306 BHTS ZZ C4 200°	30	72	19	3600	14,6	16,3
6307 BHTS ZZ C4 200°	35	80	21	3200	17,1	19,0
6308 BHTS ZZ C4 200°	40	90	23	2800	22,5	25,0
6309 BHTS ZZ C4 200°	45	100	25	2400	28,8	32,0
6310 BHTS ZZ C4 200°	50	110	27	2000	34,2	38,0
6311 BHTS ZZ C4 200°	55	120	29	1800	42,7	47,5
6312 BHTS ZZ C4 200°	60	130	31	1600	46,8	52,0
6313 BHTS ZZ C4 200°	65	140	33	1400	54,0	60,0
6314 BHTS ZZ C4 200°	70	150	35	1200	61,2	68,0
6315 BHTS ZZ C4 200°	75	160	37	1000	68,8	76,5
6316 BHTS ZZ C4 200°	80	170	39	900	77,8	86,5
6317 BHTS ZZ C4 200°	85	180	41	800	86,8	96,5
6318 BHTS ZZ C4 200°	90	190	43	700	97,2	108
6319 BHTS ZZ C4 200°	95	200	45	600	106,2	118
6320 BHTS ZZ C4 200°	100	215	47	500	126,0	140

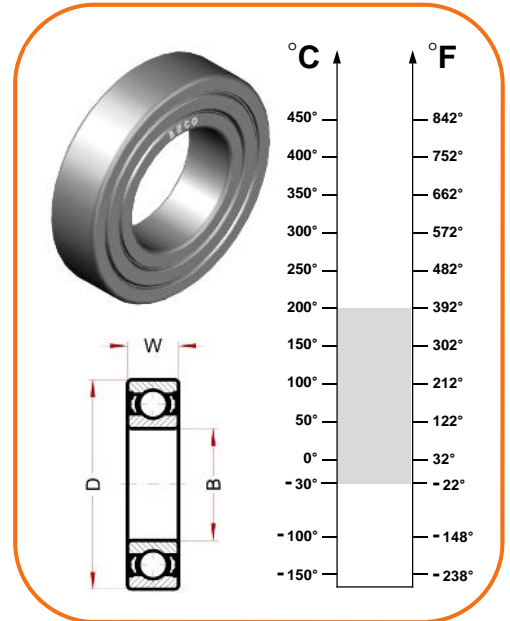

Technical characteristics:

- Bearing material: steel AISI 52100 (Chrome) stabilized to the application
- Radial Clearance C4
- Shields type ZZ
- Lubricated for life with grease for temperatures up to 200°C
- Do not need additional lubrication
- 61800 Serie bearings also available

Fields of application:

- Air conveyors
- Industrial Fans
- Packaging machinery
- Steel industry
- Ceramic Industry
- Papermaking industry



12100 Cuneo - Italy

phone: 0039 0171 66883

fax: 0039 0171 648913

www.becoitalia.it