

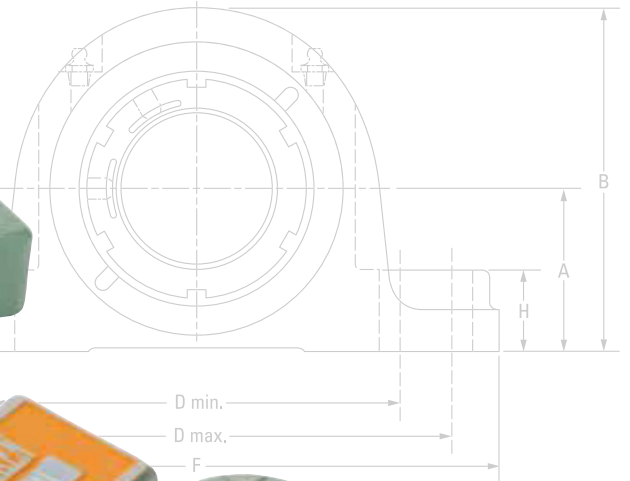

TIMKEN

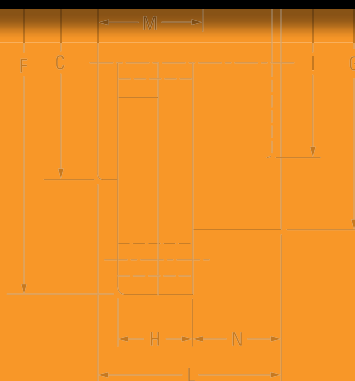

TIMKEN® SAF SPLIT-BLOCK HOUSED UNITS

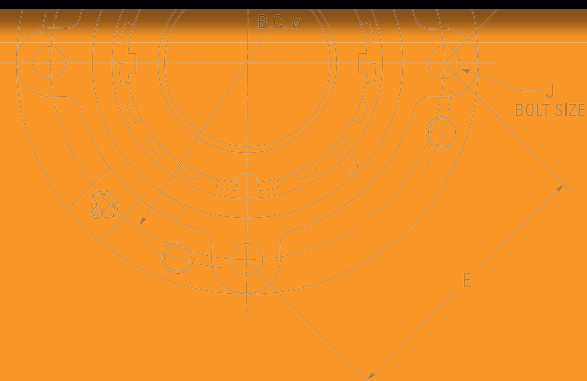



TIMKEN® HOUSED UNIT CATALOG INDEX

OVERVIEW.....	2
INTRODUCTION.....	4
SHELF LIFE POLICY.....	10
Timken® SAF Split-Block Housed Units.....	D-1



GROW STRONGER WITH TIMKEN

Every day, people around the world count on the strength of Timken. Our expertise in metallurgy, friction management and mechanical power transmission helps them accelerate improvements in productivity and uptime.

We supply products and services that can help keep your operations moving forward, whether you need drive train kits for commercial vehicles, durable housings for bearings in dirty environments, couplings that avoid metal-to-metal contact between motors and gearboxes, repair services for rail bearings, steel for an aircraft engine shaft, or other products and services for your applications.

When you choose Timken, you receive more than high-quality products and services: You gain a worldwide team of highly trained and experienced Timken people committed to working collaboratively with you to improve your business.

Globally, our 20,000 people provide reliable answers for a wide range of operations in manufacturing, mining, medical equipment, aerospace, transportation, oil and gas – and other diverse industries.

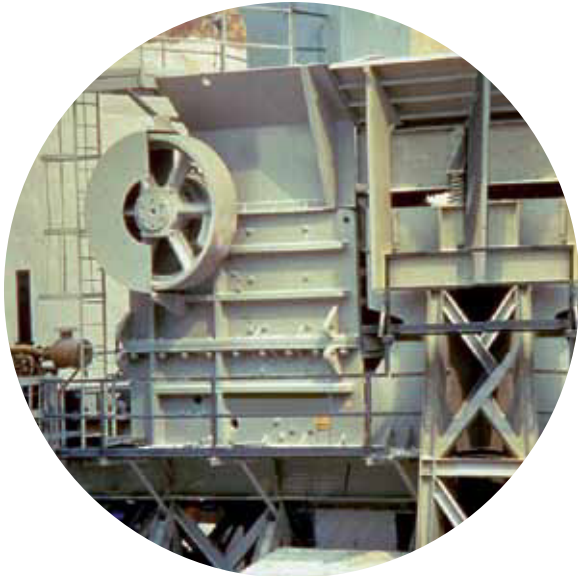

INCREASE YOUR EQUIPMENT UPTIME

In addition to high-quality bearings, engineered steel and mechanical power transmission components, we provide valuable integrated products and services. For example, we offer repair services and equipment monitoring equipment that can alert you to problems before they impact your uptime.

Additionally, we offer a broad selection of seals, premium lubricants, lubricators, couplings and chain to keep your operations moving smoothly.

Our 10 technology centers in the United States, Europe and Asia help pioneer tomorrow's innovations with extensive basic and applied scientific research programs. Through internal development and strategic acquisition of innovative companies, we continue to expand our portfolio of highly engineered bearings, steel and components.





RUGGED TIMKEN® HOUSED UNITS HELP PROTECT YOUR BEARINGS

When you choose sturdy Timken housings, your bearings can keep rolling smoothly, even in harsh environments impacted by dirt, debris, water and other contaminants. Timken engineers designed special housings to withstand tough challenges on the job.

Protected inside durable cast iron or steel, our highly engineered Timken® ball and roller bearings work hard to help you manufacture and transport materials, without excessive maintenance due to contaminants.

Choose from our selection of housed units designed with ball, tapered and spherical bearings. Select enhancements like Timken® seals, lubricants and housing covers best suited for each task. Our engineers help you choose the right combination of bearings and accessories to extend bearing life, increase uptime and reduce maintenance costs.

Of course, you can interchange existing products with Timken housed units because our bolt holes and shaft centerline dimensions are designed to conform to industry standards.

Timken® housed units reflect our strengths in metallurgy, engineering and manufacturing. We produce all our bearings in adherence with the Timken Quality Management System for consistency in all our facilities around the world.





TIMKEN® BALL HOUSED UNITS OFFER EASY INSTALLATION, FLEXIBLE OPTIONS

Timken® ball housed units, available in a variety of sizes and types, feature wide-inner-ring ball bearings that provide additional shaft support and locking options. The Timken® wide-inner-ring ball bearing is designed for straight shafts and can be positioned without shoulders, locknuts or adapters.

For easy installation, our ball housed units can be ordered pre-assembled with bearings, housings, seals and locking systems. Choose from pillow blocks, flanged cartridges, take-up units and cylindrical cartridges. Our cast-iron, pressed-steel and other optional materials give you durable choices for the exterior covers. Timken® locking options include set screws, self-locking collars and concentric collars.

Timken® Shaft Guarding Technology™ deters set-screw damage to shafts by placing a hardened band in the groove along the inner ring of the bearing. The set screws press against the band to transfer gripping pressure onto the shaft, preventing nicks, as well as raised-metal or permanent shaft damage. The stainless-steel band resists corrosion on the shaft. This system is particularly helpful for applications where it would be expensive and time-consuming to replace shafts.

TYPICAL INDUSTRIES AND APPLICATIONS

Use Timken ball bearing housed units in agricultural applications, fans, blowers, food processing devices and conveyors.



TIMKEN® TYPE E HOUSED UNITS REPEL CONTAMINANTS, ENHANCE PERFORMANCE

Timken® Type E tapered roller bearing housed units feature double-lip seals and locking collars that protect against water and other contaminants. This double-lip seal design blocks debris and retains grease better than single-lip or triple-lip seals, according to Timken 2012 laboratory tests.

Its cast-iron exterior includes a corrosion-resistant electro-coat finish for the housing and collar, a more durable shield than industry-standard powder coating or black oxide. Set screws with nylon patches reduce back-out, even in rigorous applications.

Premium Timken® tapered roller bearings inside Type E housings are manufactured with advanced technology that results in longer predicted useful bearing life than other housed units with standard bearings. Designed with optimized bearing profiles and improved surface finishes, Timken tapered roller bearings operate efficiently within the housing.

TYPICAL INDUSTRIES AND APPLICATIONS

Use Timken Type E housings for pulp and paper, power generation, mining, cement and aggregate industries. Our Type E housed units also are widely used in equipment for air-handling and treatment of water and waste water. Other common machine applications include mixers, washers, shredders, mills and oven/furnace roller beds.



TIMKEN® SPHERICAL ROLLER BEARING SOLID-BLOCK HOUSED UNITS WITHSTAND HARSH CONDITIONS

Timken® spherical roller bearing solid-block housed units stand up to rugged conditions. Composed of solid steel, they withstand most falling debris and handle up to ± 1.5 degrees of misalignment. The steel used in these products is up to two times stronger than cast iron, which may break or pound out in tough applications.

Timken spherical roller bearing solid-block housed units come in five locking configurations: single and double set screws, eccentric locks for reversing applications, tapered-adaptor locks and double-tapered locks.

Choose from three sealing options: labyrinth seals (for high-speed, high-temperature applications) and triple-lip seals made of either nitrile or urethane. Timken® steel auxiliary covers provide an extra layer of protection, and they can be filled with Timken lubricants.

TYPICAL INDUSTRIES AND APPLICATIONS

Use Timken spherical roller bearing solid-block housed units in metals mills, aggregate and cement, mining, power generation, agriculture, pulp, paper, sawmills and other forest industries.



TIMKEN® SAF SPLIT-BLOCK HOUSED UNITS BEAR HEAVY LOADS

Timken® SAF split-block housed units are available in rugged cast iron, ductile iron or cast steel to match a range of industrial environments. Our Timken SAF housed units have separate, matched caps and bases. In larger sizes where housed units are heavier, this split-block design eases installation. Remove the cap using a pry-tool slot for bearing inspection, service and replacement.

Available in a variety of shaft sizes, Timken SAF units offer the choice of tapered-bore design for easy mounting or a straight-bore design for better axial location. The block can be converted from fixed to float by removing the stabilizing ring. Several sealing options protect against contamination, including a standard seal, which is a precision aluminum triple-ring labyrinth seal.

TYPICAL INDUSTRIES AND APPLICATIONS

Use Timken SAF housed bearings in power generation, coal, mining, aggregate, cement, metals, pulp, paper and other forestry operations, water treatment and food processing industries. Applications include warehousing, conveyors, movable bridges/heavy structures, industrial fans and blowers.



HOW TO USE THIS CATALOG

We designed this catalog to help you find the Timken housed units best suited to your specifications.

Timken offers an extensive range of bearings and accessories in both imperial and metric sizes. For your convenience, size ranges are indicated in millimeters and inches. Contact your Timken engineer to learn more about our complete line for the special needs of your application.

This publication contains dimensions, tolerances and load ratings, as well as engineering sections describing fitting practices for shafts and housings, internal clearances, materials and other bearing features. It provides valuable assistance in the initial consideration of the type and characteristics of the bearings that may best suit your particular needs.

ISO and ANSI/ABMA, as used in this publication, refer to the International Organization for Standardization and the American National Standards Institute/American Bearing Manufacturers Association.

Updates are made periodically to this catalog. Visit www.timken.com for the most recent version of the Timken® Housed Unit Catalog.

DISCLAIMER

This catalog is provided solely to give you analysis tools and data to assist you in your product selection. Product performance is affected by many factors beyond the control of Timken. Therefore, you must validate the suitability and feasibility of all product selections for your applications.

Timken products are sold subject to Timken terms and conditions of sale, which include our limited warranty and remedy. You can find these at <http://www.timken.com/en-us/purchase/Pages/TermsandConditionsofSale.aspx>.

Please consult with your Timken engineer for more information and assistance.

Every reasonable effort has been made to ensure the accuracy of the information in this writing, but no liability is accepted for errors, omissions or for any other reason.





SHELF LIFE AND STORAGE OF GREASE-LUBRICATED BEARINGS AND COMPONENTS

To help you get the most value from our products, Timken provides guidelines for the shelf life of grease-lubricated ball and roller bearings, components and assemblies. Shelf life information is based on Timken and industry test data and experience.



SHELF LIFE POLICY

Shelf life should be distinguished from lubricated bearing/component design life as follows:

- Shelf life of the grease-lubricated bearing/component represents the period of time prior to use or installation.
- The shelf life is a portion of the anticipated aggregate design life. It is impossible to accurately predict design life due to variations in lubricant bleed rates, oil migration, operating conditions, installation conditions, temperature, humidity and extended storage.
- Shelf life values, available from Timken, represent a maximum limit and assume adherence to the storage and handling guidelines suggested in this catalog or by a Timken associate. Deviations from the Timken storage and handling guidelines may reduce shelf life. Any specification or operating practice that defines a shorter shelf life should be used.

Timken cannot anticipate the performance of the grease lubricant after the bearing or component is installed or placed in service.

TIMKEN IS NOT RESPONSIBLE FOR THE SHELF LIFE OF ANY BEARING/COMPONENT LUBRICATED BY ANOTHER PARTY.

European REACH Compliance

Timken lubricants, greases and similar products sold in standalone containers or delivery systems are subject to the European REACH (**R**egistration, **E**valuation, **A**uthorization and **R**estriction of **C**hemicals) directive. For import into the European Union, Timken can sell and provide only those lubricants and greases that are registered with ECHA (**E**uropean **C**hemical **A**gency). For further information, please contact your Timken engineer.

STORAGE

Timken suggests the following storage guidelines for our finished products (bearings, components and assemblies, referred to as “products”):

- Unless directed otherwise by Timken, products should be kept in their original packaging until they are ready to be placed into service.
- Do not remove or alter any labels or stencil markings on the packaging.
- Products should be stored in such a way that the packaging is not pierced, crushed or otherwise damaged.
- After a product is removed from its packaging, it should be placed into service as soon as possible.
- When removing a product that is not individually packaged from a bulk pack container, the container should be resealed immediately after the product is removed.
- Do not use product that has exceeded its shelf life as defined in the Timken shelf life guidelines statement.
- The storage area temperature should be maintained between 0° C (32° F) and 40° C (104° F); temperature fluctuations should be minimized.
- The relative humidity should be maintained below 60 percent and the surfaces should be dry.
- The storage area should be kept free from airborne contaminants such as, but not limited to, dust, dirt, harmful vapors, etc.
- The storage area should be isolated from undue vibration.
- Extreme conditions of any kind should be avoided.

Due to the fact that Timken is not familiar with your particular storage conditions, we strongly suggest following these guidelines. However, you may be required by circumstances or applicable government requirements to adhere to stricter storage requirements.





Most bearing components typically ship protected with a corrosion-preventive compound that is not a lubricant. These components may be used in oil-lubricated applications without removal of the corrosion-preventive compound. When using some specialized grease lubrications, we advise you to remove the corrosion-preventive compound before packing the bearing components with suitable grease.

We pre-pack most housed unit types in this catalog with general-purpose grease suitable for their normal applications. It may be necessary for you to frequently replenish the grease for optimum performance.

Be careful in selecting lubrication, however, since different lubricants are often incompatible. You may order housed units pre-lubricated with a specified lubrication.

When you receive a bearing or housed unit shipment, do not remove products from their packaging until they are ready for mounting so they do not become corroded or contaminated.

Store bearings and housed units in an appropriate atmosphere so they remain protected for the intended period.

**WARNING**

Failure to observe the following warnings could create a risk of death or serious injury.

Proper maintenance and handling practices are critical. Failure to follow selection recommendations and installation instructions and to maintain proper lubrication can result in equipment failure.

Overheated bearings can ignite explosive atmospheres. Special care must be taken to properly select, install, maintain, and lubricate housed unit bearings that are used in or near atmospheres that may contain explosive levels of combustible gases or accumulations of dust such as from grain, coal, or other combustible materials. Consult your equipment designer or supplier for installation and maintenance instructions.

**CAUTION**

Failure to follow these cautions could create a risk of injury.

Do not use damaged housed units. The use of a damaged housed unit can result in equipment damage and/or injury.

CAUTION

Failure to follow these cautions may result in property damage.

If hammer and bar are used for installation or removal of a part, use a mild steel bar (e.g., 1010 or 1020 grade). Mild steel bars are less likely to cause release of high-speed fragments from the hammer, bar or the part being removed.

NOTE

Do not use excessive force when mounting or dismantling the unit.

Follow all tolerance, fit, and torque recommendations.

Always follow the Original Equipment Manufacturer's installation and maintenance guidelines.

Ensure proper alignment.

Never weld housed units.

Do not heat components with an open flame.

Do not operate at bearing temperatures above 121° C (250° F).

Warnings for this product line are in this catalog and posted on www.timken.com/en-us/products/warnings/Pages/TimkenHousedUnitWarnings.aspx.





TIMKEN® SAF SPLIT-BLOCK HOUSED UNITS

Timken’s split-block spherical pillow blocks combine rugged cast-iron or cast-steel housings with high-capacity spherical roller bearings to meet the toughest demands of heavy industry. The convenient split-housing design simplifies assembly and service. Each pillow block contains an advanced-design spherical roller bearing with improved geometry and raceway finish for optimal load capacity and service life. Timken manufactures pillow blocks in two main styles: SAF and SDAF. The larger SDAF block is suggested for extremely heavy duty applications.

Updates are made periodically to this catalog. Visit www.timken.com for the most recent version of the Timken® Housed Unit Catalog.

TYPICAL INDUSTRIES AND APPLICATIONS

Common uses include processing and material handling equipment found in many industries, including power generation (coal), mining, aggregate, cement, metal mills, pulp, paper and other forestry operations, water treatment and food processing. Applications include conveyors, movable bridges/heavy structures, industrial fans and blowers.

Engineering D-3
 SAF Lubrication D-23
 Spherical Roller Bearing Nomenclature D-36
 Spherical Roller Bearing Product Data Tables D-37
 SAF Housed Unit Nomenclature D-46
 SAF Housed Unit Introduction D-47
 SAF Pillow Block Product Data Tables D-50
 SAF Spherical Roller Bearing Inch Accessories D-83

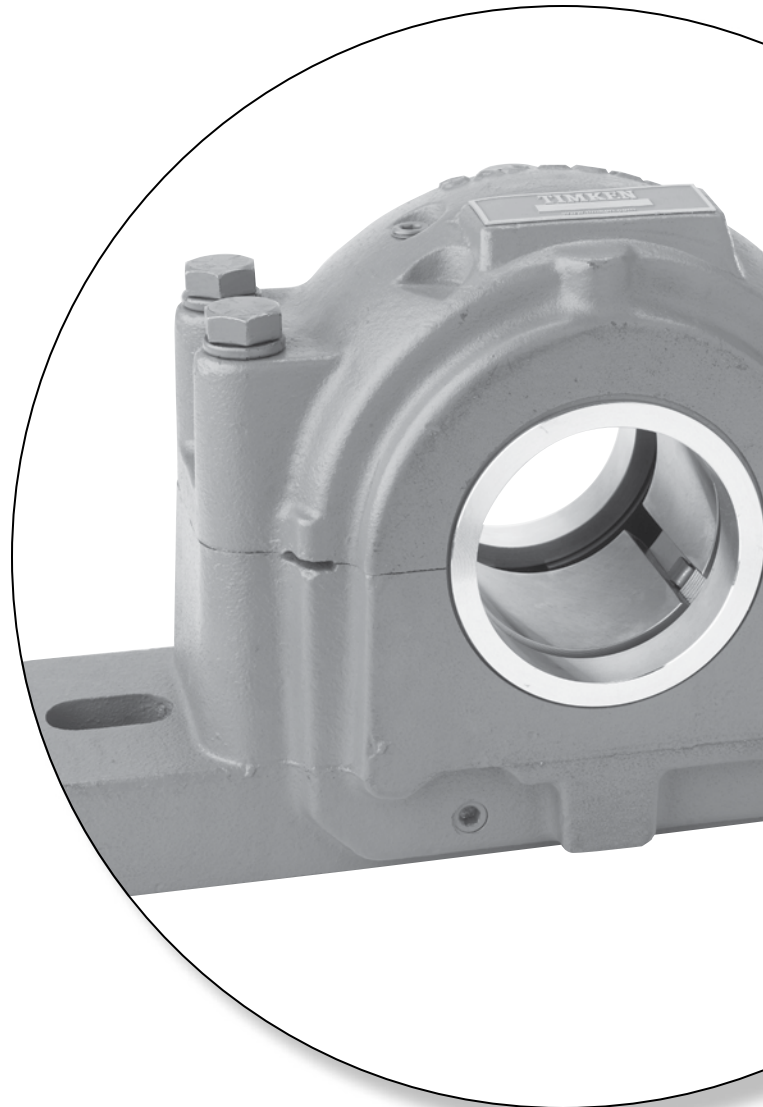



WARNING

Failure to observe the following warnings could create a risk of death or serious injury.

Proper maintenance and handling practices are critical. Always follow installation instructions and maintain proper lubrication.

Overheated bearings can ignite explosive atmospheres. Special care must be taken to properly select, install, maintain, and lubricate housed unit bearings that are used in or near atmospheres that may contain explosive levels of combustible gases or accumulations of dust such as from grain, coal, or other combustible materials. Consult your equipment designer or supplier for installation and maintenance instructions.



CAUTION

Failure to follow these cautions could create a risk of injury.

Do not use damaged housed units. The use of a damaged housed unit can result in equipment damage and/or injury.

CAUTION

Failure to follow these cautions may result in property damage.

If hammer and bar are used for installation or removal of a part, use a mild steel bar (e.g., 1010 or 1020 grade). Mild steel bars are less likely to cause release of high-speed fragments from the hammer, bar or the part being removed.

NOTE

Do not use excessive force when mounting or dismantling the unit.

Follow all tolerance, fit and torque recommendations.

Always follow the Original Equipment Manufacturer's installation and maintenance guidelines.

Ensure proper alignment.

Never weld housed units.

Do not heat components with an open flame.

Do not operate at bearing temperatures above 121°C (250°F).

DISCLAIMER

This catalog is provided solely to give you analysis tools and data to assist you in your product selection. Product performance is affected by many factors beyond the control of Timken. Therefore, you must validate the suitability and feasibility of all product selections for your applications.

Timken products are sold subject to Timken terms and conditions of sale, which include our limited warranty and remedy. You can find these at <http://www.timken.com/en-us/purchase/Pages/TermsandConditionsofSale.aspx>.

Please consult with your Timken engineer for more information and assistance.

Every reasonable effort has been made to ensure the accuracy of the information in this writing, but no liability is accepted for errors, omissions or for any other reason.

Updates are made periodically to this catalog. Visit www.timken.com for the most recent version of the Timken® Housed Unit Catalog.

Warnings for this product line are in this catalog and posted on www.timken.com/en-us/products/warnings/Pages/TimkenHousedUnitWarnings.aspx.



ENGINEERING

The following topics are covered within this engineering section:

- Spherical roller bearing design types.
- Shaft fitting practice and mounting recommendations.

This engineering section is not intended to be comprehensive, but does serve as a useful guide in spherical roller bearing and SAF pillow block housing selection.

To view the complete engineering catalog, please visit www.timken.com. To order the catalog, please contact your Timken engineer and request a copy of the Timken Engineering Manual, order number 10424.

Radial Spherical Roller Bearing Types and Cages	D-4
Spherical Roller Bearing Tolerances	D-4
Spherical Roller Bearing Mounting, Fitting, Setting and Installation	D-7
Shaft Fits for Cylindrical Bore Bearings	D-15
Fitting Practice Tables	D-16

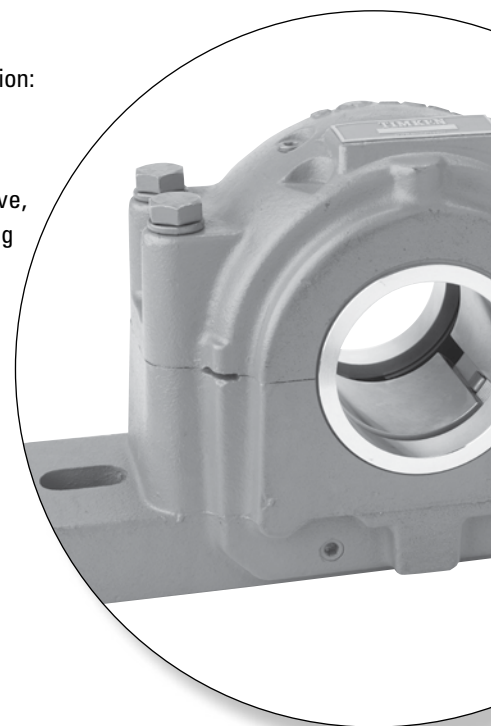

RADIAL SPHERICAL ROLLER BEARING TYPES AND CAGES

The principle styles of radial spherical roller bearings that Timken offers are:

- ≤280 mm bore: EJ, EM and EMB
- >280 mm bore: YM and YMB

Above suffixes correspond to different types of designs depending on a bearing size and geometry. Main differences are the cage type used in the assembly. Spherical roller bearings with an EJ cage suffix are fitted with a stamped-steel cage. YM/EM/YMB suffixes are used with brass cage designs.

The newly redesigned Timken® EJ, EM and EMB bearings offer higher load ratings, increased thermal speed ratings and reduced

operating temperatures compared to the previous offering.

In addition to these improvements, cage designs vary between the different styles as noted below.

Style	Cage Design
EJ	Land-riding steel cage; one per row
EM/YM	Roller-riding one-piece brass cage
EMB/YMB	Land-riding one-piece brass cage

Most Timken® spherical roller bearings are available with a cylindrical bore as well as a tapered bore. Tapered bore bearing part numbers are designated with a K suffix.

METRIC SYSTEM TOLERANCES

Spherical roller bearings are manufactured to a number of specifications, with each having classes that define tolerances on dimensions such as bore, O.D., width and runout. Metric bearings have been manufactured to corresponding standard negative tolerances.

The following table summarizes the different specifications and classes for spherical roller bearings and other available Timken bearing lines. For the purposes of this catalog, ISO specifications are shown for spherical roller bearings.

Boundary dimension tolerances for spherical roller bearing usage are listed in the following tables. These tolerances are provided for use in selecting bearings for general applications, in conjunction with the bearing mounting and fitting practices offered in later sections.

TABLE D-1. BEARING SPECIFICATIONS AND CLASSES

System	Specification	Bearing Type	Standard Bearing Class		Precision Bearing Class			
			P0	P6	P5	P4	P2	--
Metric	ISO/DIN	All Bearing Types						
Imperial	ABMA	Spherical	RBEC 1	RBEC 3	RBEC 5	RBEC 7	RBEC 9	--

Standard Timken radial spherical roller bearings maintain normal tolerances according to ISO 492. Tables D-2 and D-3 list the critical tolerances for these bearing types. Timken SAF housings are supplied with bearings that conform to ISO P0, or standard tolerances.

The term deviation is defined as the difference between a single ring dimension and the nominal dimension. For metric tolerances, the nominal dimension is at a +0 mm (0 in.) tolerance. The deviation is the tolerance range for the listed parameter. Variation is defined as the difference between the largest and smallest measurements of a given parameter for an individual ring.

TABLE D-2. SPHERICAL ROLLER BEARING TOLERANCES – INNER RING (METRIC)⁽¹⁾

Bearing Bore		Bore Deviation ⁽²⁾ Δ_{dmp}			Width Variation V_{BS}			Radial Runout K_{ia}			Face Runout with Bore S_d	Axial Runout S_{ia}	Width Deviation Inner & Outer Rings ⁽²⁾ Δ_{Bs} and Δ_{Cs}	
Over	Incl.	P0	P6	P5	P0	P6	P5	P0	P6	P5	P5	P5	P0, P6	P5
mm	mm	mm	mm	mm	mm	mm	mm	mm	mm	mm	mm	mm	mm	mm
in.	in.	in.	in.	in.	in.	in.	in.	in.	in.	in.	in.	in.	in.	in.
2.5000 0.0984	10.000 0.3937	-0.008 -0.0003	-0.007 -0.0003	-0.005 -0.0002	0.015 0.0006	0.015 0.0006	0.005 0.0002	0.010 0.0004	0.006 0.0002	0.004 0.0002	0.007 0.0003	0.007 0.0003	-0.120 -0.0047	-0.040 -0.0157
10.000 0.3937	18.000 0.7087	-0.008 -0.0003	-0.007 -0.0003	-0.005 -0.0002	0.020 0.0008	0.020 0.0008	0.005 0.0002	0.010 0.0004	0.007 0.0003	0.004 0.0002	0.007 0.0003	0.007 0.0003	-0.120 -0.0047	-0.080 -0.0031
18.000 0.7087	30.000 1.1811	-0.010 -0.0004	-0.008 -0.0003	-0.006 -0.0002	0.020 0.0008	0.020 0.0008	0.005 0.0002	0.013 0.0005	0.008 0.0003	0.004 0.0002	0.008 0.0003	0.008 0.0003	-0.120 -0.0047	-0.120 -0.0047
30.000 1.1811	50.000 1.9685	-0.012 -0.0005	-0.010 -0.0004	-0.008 -0.0003	0.020 0.0008	0.020 0.0008	0.005 0.0002	0.015 0.0006	0.010 0.0004	0.005 0.0002	0.008 0.0003	0.008 0.0003	-0.120 -0.0047	-0.120 -0.0047
50.000 1.9685	80.000 3.1496	-0.015 -0.0006	-0.012 -0.0005	-0.009 -0.0004	0.025 0.0010	0.025 0.0010	0.006 0.0002	0.020 0.0008	0.010 0.0004	0.005 0.0002	0.008 0.0003	0.008 0.0003	-0.150 -0.0059	-0.150 -0.0059
80.000 3.1496	120.000 4.7244	-0.020 -0.0008	-0.015 -0.0006	-0.010 -0.0004	0.025 0.0010	0.025 0.0010	0.007 0.0003	0.025 0.0010	0.013 0.0005	0.006 0.0002	0.009 0.0004	0.009 0.0004	-0.200 -0.0079	-0.200 -0.0079
120.000 4.7244	150.000 5.9055	-0.025 -0.0010	-0.018 -0.0007	-0.013 -0.0005	0.030 0.0012	0.030 0.0012	0.008 0.0003	0.030 0.0012	0.018 0.0007	0.008 0.0003	0.010 0.0004	0.010 0.0004	-0.250 -0.0098	-0.250 -0.0098
150.000 5.9055	180.000 7.0866	-0.025 -0.0010	-0.018 -0.0007	-0.013 -0.0005	0.030 0.0012	0.030 0.0012	0.008 0.0003	0.030 0.0012	0.018 0.0007	0.008 0.0003	0.010 0.0004	0.010 0.0004	-0.250 -0.0098	-0.250 -0.0098
180.000 7.0866	250.000 9.8425	-0.030 -0.0012	-0.022 -0.0009	-0.015 -0.0006	0.030 0.0012	0.030 0.0012	0.010 0.0004	0.040 0.0016	0.020 0.0008	0.010 0.0004	0.011 0.0004	0.013 0.0005	-0.300 -0.0018	-0.300 -0.0018
250.000 9.8425	315.000 12.4016	-0.035 -0.0014	-0.025 -0.0010	-0.018 -0.0007	0.035 0.0014	0.035 0.0014	0.013 0.0005	0.050 0.0020	0.025 0.0010	0.013 0.0005	0.013 0.0005	0.015 0.0006	-0.350 -0.0138	-0.350 -0.0138
315.000 12.4016	400.000 15.7480	-0.040 -0.0016	-0.030 -0.0012	-0.023 -0.0009	0.040 0.0016	0.040 0.0016	0.015 0.0006	0.060 0.0024	0.030 0.0012	0.015 0.0006	0.015 0.0006	0.020 0.0008	-0.400 -0.0157	-0.400 -0.0157
400.000 15.7480	500.000 19.6850	-0.045 -0.0018	-0.035 -0.0014	-	0.050 0.0020	0.045 0.0018	-	0.065 0.0026	0.035 0.0014	-	-	-	-0.450 -0.0177	-
500.000 19.6850	630.000 24.8031	-0.050 -0.0020	-0.040 -0.0016	-	0.060 0.0024	0.050 0.0020	-	0.070 0.0028	0.040 0.0016	-	-	-	-0.500 -0.0197	-
630.000 24.8031	800.000 31.4961	-0.075 -0.0030	-	-	0.070 0.0028	-	-	0.080 0.0031	-	-	-	-	-0.750 -0.0295	-

⁽¹⁾Symbol definitions are found on pages 32-33 of the Timken Engineering Manual (order number 10424).

⁽²⁾Tolerance range is from +0 to value listed.

NOTE: Tolerance and shaft diameters are shown in the table as variances from nominal bearing bore.



TABLE D-3. SPHERICAL ROLLER BEARING TOLERANCES – OUTER RING (METRIC)⁽¹⁾

Bearing O.D.		Outside Deviation ⁽²⁾			Width Variation		Radial Runout			Axial Runout	Outside Diameter Runout With Face
Over	Incl.	Δ_{Dmp}			V_{CS}		K_{ea}			S_{ea}	S_D
		P0	P6	P5	P0	P6	P0	P6	P5	P5	P5
mm	mm	mm	mm	mm	mm	mm	mm	mm	mm	mm	mm
in.	in.	in.	in.	in.	in.	in.	in.	in.	in.	in.	in.
0.000 0.0000	18.000 0.7087	-0.008 -0.0003	-0.007 -0.0003	-0.005 -0.0002	0.015 0.0006	0.005 0.0002	0.015 0.0006	0.008 0.0003	0.005 0.0002	0.008 0.0003	0.008 0.0003
18.000 0.7087	30.000 1.1811	-0.009 -0.0004	-0.008 -0.0003	-0.006 -0.00024	0.020 0.0008	0.005 0.0002	0.015 0.0006	0.009 0.0004	0.006 0.00024	0.008 0.0003	0.008 0.0003
30.000 1.1811	50.000 1.9685	-0.011 -0.0004	-0.009 -0.0004	-0.007 -0.0003	0.020 0.0008	0.005 0.0002	0.020 0.0008	0.010 0.0004	0.007 0.0003	0.008 0.0003	0.008 0.0003
50.000 1.9685	80.000 3.1496	-0.013 -0.0005	-0.011 -0.0004	-0.009 -0.0004	0.025 0.0010	0.006 0.00024	0.025 0.0010	0.013 0.0005	0.008 0.0003	0.010 0.0004	0.008 0.0003
80.000 3.1496	120.000 4.7244	-0.015 -0.0006	-0.013 -0.0005	-0.010 -0.0004	0.025 0.0010	0.008 0.0003	0.035 0.0014	0.018 0.0007	0.010 0.0004	0.011 0.0004	0.009 0.0004
120.000 4.7244	150.000 5.9055	-0.018 -0.0007	-0.015 -0.0006	-0.011 -0.0004	0.030 0.0012	0.008 0.0003	0.040 0.0016	0.020 0.0008	0.011 0.0004	0.013 0.0005	0.010 0.0004
150.000 5.9055	180.000 7.0866	-0.025 -0.0010	-0.018 -0.0007	-0.013 -0.0005	0.030 0.0012	0.008 0.0003	0.045 0.0018	0.023 0.0009	0.013 0.0005	0.014 0.0006	0.010 0.0004
180.000 7.0866	250.000 9.8425	-0.030 -0.0012	-0.020 -0.0008	-0.015 -0.0006	0.030 0.0012	0.010 0.0004	0.050 0.0020	0.025 0.0010	0.015 0.0006	0.015 0.0006	0.011 0.0004
250.000 9.8425	315.000 12.4016	-0.035 -0.0014	-0.025 -0.0010	-0.018 -0.0007	0.035 0.0014	0.011 0.0004	0.060 0.0024	0.030 0.0012	0.018 0.0007	0.018 0.0007	0.013 0.0005
315.000 12.4016	400.000 15.7480	-0.040 -0.0016	-0.028 -0.0011	-0.020 -0.0008	0.040 0.0016	0.013 0.0005	0.070 0.0028	0.035 0.0014	0.020 0.0008	0.020 0.0008	0.013 0.0005
400.000 15.7480	500.000 19.6850	-0.045 -0.0018	-0.033 -0.0013	-0.023 -0.0009	0.045 0.0018	0.015 0.0006	0.080 0.0031	0.040 0.0016	0.023 0.0009	0.023 0.0009	0.015 0.0006
500.000 19.6850	630.000 24.8031	-0.050 -0.0020	-0.038 -0.0015	-0.028 -0.0011	0.050 0.0020	0.018 0.0007	0.100 0.0039	0.050 0.0020	0.025 0.0010	0.025 0.0010	0.018 0.0007
630.000 24.8031	800.000 31.4961	-0.075 -0.0030	-0.045 -0.0018	-0.035 -0.0014	–	0.020 0.0008	0.120 0.0047	0.060 0.0024	0.030 0.0012	0.030 0.0012	0.020 0.0008
800.000 31.4961	1000.000 39.3701	-0.100 -0.0040	-0.060 -0.0024	–	–	–	0.140 0.0055	0.075 0.0030	–	–	–
1000.000 39.3701	1250.000 49.2126	-0.125 -0.0050	–	–	–	–	0.160 0.0063	–	–	–	–

⁽¹⁾Symbol definitions are found on pages 32-33 of the Timken Engineering Manual (order number 10424).

⁽²⁾Tolerance range is from +0 to value listed.

NOTE: Tolerance and shaft diameters are shown in the table as variances from nominal bearing bore.

SPHERICAL ROLLER BEARING MOUNTING, FITTING, SETTING AND INSTALLATION

MOUNTING

Spherical roller bearings can be mounted individually, but most often are mounted in combination with another spherical roller bearing or a cylindrical roller bearing.

With spherical roller bearings, typically one bearing is fixed axially and the other is mounted with loose fits and axial space. This allows movement or float for environmental conditions such as uneven thermal growth between shaft and housing. In SAF housings, a stabilizing ring, sometimes called a locating ring, is provided. When this ring is installed in the assembly, it creates a fixed bearing. When it is removed, and the bearing is properly located in the housing, the bearing can float freely.

Fig. D-1 shows a fixed SAF housing with a stabilizing ring installed and a float bearing without the stabilizing ring.

FITTING PRACTICE

Tables D-6 through D-8 on pages D-15 through D-21 list the recommended fitting practice for spherical roller bearing inner rings on shafts. The tables assume:

- The bearing is of normal precision.
- The shaft is solid and made from steel.
- The bearing seats are ground or accurately turned to less than approximately 1.6 Ra finish.

The suggested fit symbols are in accordance with ISO 286. For help with recommended fitting practice, contact your Timken engineer.

As a general guideline, rotating inner rings should be applied with an interference fit. Loose fits may permit the inner rings to creep or turn, and wear the shaft and the backing shoulder. This wear may result in excessive bearing looseness and possible bearing and shaft damage. Additionally, abrasive metal particles resulting from creep or turning may enter into the bearing and cause damage and vibration.

The load conditions and bearing envelope dimensions should be used to select the suggested shaft fit from the tables.

Timken SAF housings are supplied with a predetermined loose fit practice for the bearing O.D. Contact your Timken engineer if you require the specific fit practice used for a given SAF housing.

WARNING

Failure to observe the following warnings could create a risk of death or serious injury.

Proper maintenance and handling practices are critical. Always follow installation instructions and maintain proper lubrication.

Overheated bearings can ignite explosive atmospheres. Special care must be taken to properly select, install, maintain, and lubricate housed unit bearings that are used in or near atmospheres that may contain explosive levels of combustible gases or accumulations of dust such as from grain, coal, or other combustible materials. Consult your equipment designer or supplier for installation and maintenance instructions.

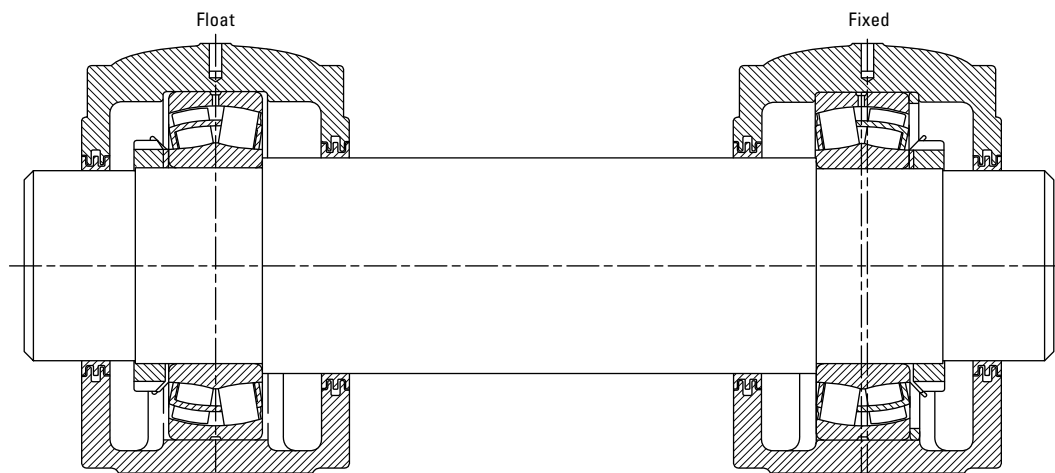

Fig. D-1. Spherical roller bearing direct mounting.

TAPERED BORE DESIGNS

Typically, tapered bore bearings are selected to simplify shaft mounting and dismounting. Since the spherical roller bearing is not separable, mounting can be simplified by use of an adapter sleeve with a cylindrical bore and tapered O.D. A tapered bore roller bearing also can be mounted directly onto a tapered shaft.

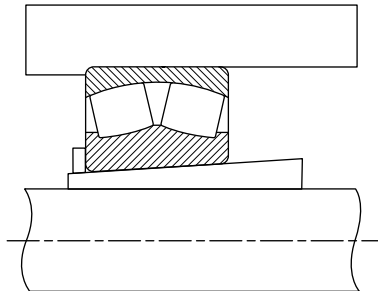

Fig. D-2. Spherical roller bearing mounted with an adapter sleeve.

Bearings with a tapered bore typically require a tighter fit on the shaft than bearings with a cylindrical bore. A locknut is typically used to drive the inner ring up a tapered shaft sleeve. The locknut position is then secured by use of a lockwasher or lockplate. Timken offers a wide range of accessories to ease the assembly of spherical roller bearings with a tapered bore (see page D-11). For approximating the clearance loss for axial drive-up, an 85 percent radial loss approximation can be used. That is, the radial clearance loss per axial drive-up can roughly be approximated as $71 \mu\text{m}/\text{mm}$ for a 1:12 tapered. Table D-5 on page D-10 provides a direct relation between suggested RIC (radial internal clearance) reduction due to installation and the corresponding axial displacement of the inner ring.

SETTING

To achieve appropriate operating clearance, attention must be paid to the effects that fitting practice and thermal gradients have within the bearing.

FITTING PRACTICE

- An interference fit between the inner ring and a solid steel shaft will reduce the radial clearance within the bearing by approximately 80 percent of the fit.
- Spherical roller bearings with a tapered bore require a slightly greater interference fit on the shaft than a cylindrical bore bearing.

NOTE

It is critical to select the RIC that allows for this reduction.

THERMAL GRADIENTS

- Thermal gradients within the bearing are primarily a function of the bearing rotational speed. As speed increases, thermal gradients increase, thermal growth occurs and the radial clearance is reduced.
- As a rule of thumb, radial clearance should be increased for speeds in excess of 70 percent of the speed rating.

For help selecting the correct radial internal clearance for your application, consult with your Timken engineer.

Radial internal clearance tolerances are listed in tables D-4 and D-5 for spherical roller bearings.

Spherical roller bearings are ordered with a specified standard or non-standard radial internal clearance value. The standard radial internal clearances are designated as C2, C0 (normal), C3, C4 or C5 and are in accordance with ISO 5753. C2 represents the minimum clearance and C5 represents the maximum clearance. Non-standardized values also are available by special request.

The clearance required for a given application depends on the desired operating precision, the rotational speed of the bearing, and the fitting practice used. SAF housings are supplied with a C3 clearance bearing, though other clearances may be ordered for specific applications, such as a C4 clearance for a paper machine dryer. Typically, larger clearance reduces the operating load zone of the bearing, increases the maximum roller load, and reduces the bearing's expected life. However, a spherical roller bearing that has been put into a preload condition can experience premature bearing damage caused by excessive heat generation and/or material fatigue. As a general guideline, spherical roller bearings should not operate in a preloaded condition.

TABLE D-4. RADIAL INTERNAL CLEARANCE LIMITS – SPHERICAL ROLLER BEARINGS – CYLINDRICAL BORE

Bore (Nominal)		Cylindrical Bore					
		Normal C0		C4			
		Min.	Max.	Min.	Max.		
Over	Incl.	C2		C3		C5	
		Min.	Max.	Min.	Max.	Min.	Max.
mm in.	mm in.	mm in.	mm in.	mm in.	mm in.	mm in.	mm in.
20 0.9449	30 1.1811	0.015 0.0006	0.025 0.001	0.04 0.0016	0.055 0.0022	0.075 0.003	0.095 0.0037
30 1.1811	40 1.5748	0.015 0.0006	0.03 0.0012	0.045 0.0018	0.06 0.0024	0.08 0.0031	1 0.0039
40 1.5748	50 1.9685	0.02 0.0008	0.035 0.0014	0.055 0.0022	0.075 0.003	0.1 0.0039	0.125 0.0049
50 1.9685	65 2.5591	0.02 0.0008	0.04 0.0016	0.065 0.0026	0.09 0.0035	0.12 0.0047	0.15 0.0059
65 2.5591	80 3.1496	0.03 0.0012	0.05 0.002	0.08 0.0031	0.11 0.0043	0.145 0.0057	0.18 0.0071
80 3.1496	100 3.9370	0.035 0.0014	0.06 0.0024	0.1 0.0039	0.135 0.0053	0.18 0.0071	0.225 0.0089
100 3.9370	120 4.7244	0.04 0.0016	0.075 0.003	0.12 0.0047	0.16 0.0063	0.21 0.0083	0.26 0.0102
120 4.7244	140 5.5118	0.05 0.002	0.095 0.0037	0.145 0.0057	0.19 0.0075	0.24 0.0094	0.3 0.0118
140 5.5118	160 6.2992	0.06 0.0024	0.11 0.0043	0.17 0.0067	0.22 0.0087	0.28 0.011	0.35 0.0138
160 6.2992	180 7.0866	0.065 0.0026	0.12 0.0047	0.18 0.0071	0.24 0.0094	0.31 0.0122	0.39 0.0154
180 7.0866	200 7.8740	0.07 0.0028	0.13 0.0051	0.2 0.0079	0.26 0.0102	0.34 0.0134	0.43 0.0169
200 7.8740	225 8.8582	0.08 0.0031	0.14 0.0055	0.22 0.0087	0.29 0.0114	0.38 0.015	0.47 0.0185
225 8.8582	250 9.8425	0.09 0.0035	0.15 0.0059	0.24 0.0094	0.32 0.0126	0.42 0.0165	0.52 0.0205
250 9.8425	280 11.0236	0.1 0.0039	0.17 0.0067	0.26 0.0102	0.35 0.0138	0.46 0.0181	0.57 0.0224
280 11.0236	315 12.4016	0.11 0.0043	0.19 0.0075	0.28 0.011	0.37 0.0146	0.5 0.0197	0.63 0.0248
315 12.4016	355 13.9764	0.12 0.0047	0.2 0.0079	0.31 0.0122	0.41 0.0161	0.55 0.0217	0.69 0.0272
355 13.9764	400 15.7480	0.13 0.0051	0.22 0.0087	0.34 0.0134	0.45 0.0177	0.6 0.0236	0.75 0.0295
400 15.7480	450 17.7165	0.14 0.0055	0.24 0.0094	0.37 0.0146	0.5 0.0197	0.66 0.026	0.82 0.0323
450 17.7165	500 19.6850	0.14 0.0055	0.26 0.0102	0.41 0.0161	0.55 0.0217	0.72 0.0283	0.9 0.0354
500 19.6850	560 22.0472	0.15 0.0059	0.28 0.011	0.44 0.0173	0.6 0.0236	0.78 0.0307	1 0.0394
560 22.0472	630 24.8031	0.17 0.0067	0.31 0.0122	0.48 0.0189	0.65 0.0256	0.85 0.0335	1.1 0.0433
630 24.8031	710 27.9528	0.19 0.0075	0.35 0.0138	0.53 0.0209	0.7 0.0276	0.92 0.0362	1.19 0.0469
710 27.9528	800 31.4961	0.21 0.0083	0.39 0.0154	0.58 0.0228	0.77 0.0303	1.01 0.0398	1.3 0.0512
800 31.4961	900 35.4331	0.23 0.0091	0.43 0.0169	0.65 0.0256	0.86 0.0339	1.12 0.0441	1.44 0.0567
900 35.4331	1000 39.3701	0.26 0.0102	0.48 0.0189	0.71 0.028	0.93 0.0366	1.22 0.048	1.57 0.0618

NOTE: Tolerance and shaft diameters are shown in the table as variances from nominal bearing bore.

TABLE D-5. RADIAL INTERNAL CLEARANCE LIMITS – SPHERICAL ROLLER BEARINGS – TAPERED BORE

Bore (Nominal)		Tapered Bore						Suggested Reduction of RIC Due to Installation		Axial Displacement of Inner Ring for RIC Reduction – Tapered Shaft ⁽¹⁾⁽²⁾				Suggested RIC After Installation ⁽¹⁾
		Normal CO		C4		C5				Taper 1:12		Taper 1:30		
		Min.	Max.	Min.	Max.	Min.	Max.			Min.	Max.	Min.	Max.	
Over	Incl.	Min.	Max.	Min.	Max.	Min.	Max.	Min.	Max.	Min.	Max.	Min.	Max.	Min.
mm	mm	mm	mm	mm	mm	mm	mm	mm	mm	mm	mm	mm	mm	mm
in.	in.	in.	in.	in.	in.	in.	in.	in.	in.	in.	in.	in.	in.	in.
20 0.9449	30 1.1811	0.02 0.0008	0.03 0.0012	0.04 0.0016	0.055 0.0022	0.075 0.003	0.095 0.0037	0.015 0.0006	0.02 0.0008	0.23 0.0091	0.30 0.0118	–	–	0.015 0.0006
30 1.1811	40 1.5748	0.025 0.001	0.035 0.0014	0.05 0.002	0.065 0.0026	0.085 0.0033	0.105 0.0041	0.02 0.0008	0.025 0.001	0.30 0.0118	0.38 0.0150	–	–	0.015 0.0006
40 1.5748	50 1.9685	0.03 0.0012	0.045 0.0018	0.06 0.0024	0.08 0.0031	0.1 0.0039	0.13 0.0051	0.025 0.001	0.03 0.0012	0.38 0.0150	0.46 0.0181	–	–	0.02 0.0008
50 1.9685	65 2.5591	0.04 0.0016	0.055 0.0022	0.075 0.003	0.095 0.0037	0.12 0.0047	0.16 0.0063	0.03 0.0012	0.038 0.0015	0.46 0.0181	0.56 0.0220	–	–	0.025 0.001
65 2.5591	80 3.1496	0.05 0.002	0.07 0.0028	0.095 0.0037	0.12 0.0047	0.15 0.0059	0.2 0.0079	0.038 0.0015	0.051 0.002	0.56 0.0220	0.76 0.0299	–	–	0.025 0.001
80 3.1496	100 3.9370	0.055 0.0022	0.08 0.003	0.11 0.0043	0.14 0.0055	0.18 0.0071	0.23 0.0091	0.046 0.0018	0.064 0.0025	0.68 0.0268	0.97 0.0382	–	–	0.036 0.0014
100 3.9370	120 4.7244	0.065 0.0026	0.1 0.0039	0.135 0.0053	0.17 0.0067	0.22 0.0087	0.28 0.011	0.051 0.002	0.071 0.0028	0.76 0.0299	1.07 0.0421	1.90 0.0748	2.54 0.1000	0.051 0.002
120 4.7244	140 5.5118	0.08 0.0031	0.12 0.0047	0.16 0.0063	0.2 0.0079	0.26 0.0102	0.33 0.013	0.064 0.0025	0.089 0.0035	0.89 0.0350	1.27 0.0500	2.29 0.0902	3.05 0.1201	0.056 0.0022
140 5.5118	160 6.2992	0.09 0.0035	0.13 0.0051	0.18 0.0071	0.23 0.0091	0.3 0.0118	0.38 0.015	0.076 0.003	0.102 0.004	1.14 0.0449	1.52 0.0598	2.67 0.1051	3.43 0.1350	0.056 0.0022
160 6.2992	180 7.0866	0.1 0.0039	0.14 0.0055	0.2 0.0079	0.26 0.0102	0.34 0.0134	0.43 0.0169	0.076 0.003	0.114 0.0045	1.14 0.0449	1.65 0.0650	2.67 0.1051	4.06 0.1598	0.061 0.0024
180 7.0866	200 7.8740	0.11 0.0043	0.16 0.0063	0.22 0.0087	0.29 0.0114	0.37 0.0146	0.47 0.0185	0.089 0.0035	0.127 0.005	1.40 0.0551	1.90 0.0748	3.05 0.1201	4.45 0.1752	0.071 0.0028
200 7.8740	225 8.8582	0.12 0.0047	0.18 0.0071	0.25 0.0098	0.32 0.0126	0.41 0.0161	0.52 0.0205	0.102 0.004	0.14 0.0055	1.52 0.0598	2.03 0.0799	3.56 0.1402	4.83 0.1902	0.076 0.003
225 8.8582	250 9.8425	0.14 0.0055	0.2 0.0079	0.27 0.0106	0.35 0.0138	0.45 0.0177	0.57 0.0224	0.114 0.0045	0.152 0.006	1.78 0.0701	2.29 0.0902	4.06 0.1598	5.33 0.2098	0.089 0.0035
250 9.8425	280 11.0236	0.15 0.0059	0.22 0.0087	0.3 0.0118	0.39 0.0154	0.49 0.0193	0.62 0.0244	0.114 0.0045	0.165 0.0065	1.78 0.0701	2.54 0.1000	4.06 0.1598	5.84 0.2299	0.102 0.004
280 11.0236	315 12.4016	0.17 0.0067	0.24 0.0094	0.33 0.013	0.43 0.0169	0.54 0.0213	0.68 0.0268	0.127 0.005	0.178 0.007	1.90 0.0748	2.67 0.1051	4.45 0.1752	6.22 0.2449	0.102 0.004
315 12.4016	355 13.9764	0.19 0.0075	0.27 0.0106	0.36 0.0142	0.47 0.0185	0.59 0.0232	0.74 0.0291	0.14 0.0055	0.19 0.0075	2.03 0.0799	2.79 0.1098	4.83 0.1902	6.60 0.2598	0.114 0.0045
355 13.9764	400 15.7480	0.21 0.0083	0.3 0.0118	0.4 0.0157	0.52 0.0205	0.65 0.0256	0.82 0.0323	0.152 0.006	0.203 0.008	2.29 0.0902	3.05 0.1201	5.33 0.2098	7.11 0.2799	0.127 0.005
400 15.7480	450 17.7165	0.23 0.0091	0.33 0.013	0.44 0.0173	0.57 0.0224	0.72 0.0283	0.91 0.0358	0.165 0.0065	0.216 0.0085	2.54 0.1000	3.3 0.1299	5.84 0.2299	7.62 0.3000	0.152 0.006
450 17.7165	500 19.6850	0.26 0.0102	0.37 0.0146	0.49 0.0193	0.63 0.0248	0.79 0.0311	1 0.0394	0.178 0.007	0.229 0.009	2.67 0.1051	3.43 0.1350	6.22 0.2449	8.00 0.3150	0.165 0.0065
500 19.6850	560 22.0472	0.29 0.0114	0.41 0.0161	0.54 0.0213	0.68 0.0268	0.87 0.0343	1.1 0.0433	0.203 0.008	0.254 0.01	3.05 0.1201	3.81 0.1500	7.11 0.2799	8.89 0.3500	0.178 0.007
560 22.0472	630 24.8031	0.32 0.0126	0.46 0.0181	0.6 0.0236	0.76 0.0299	0.98 0.0386	1.23 0.0484	0.229 0.009	0.279 0.011	3.43 0.1350	4.19 0.1650	8.00 0.3150	9.78 0.3850	0.203 0.008
630 24.8031	710 27.9528	0.35 0.0138	0.51 0.0201	0.67 0.0264	0.85 0.0335	1.09 0.0429	1.36 0.0535	0.254 0.01	0.305 0.012	3.81 0.1500	4.57 0.1799	8.89 0.3500	10.67 0.4201	0.203 0.008
710 27.9528	800 31.4961	0.39 0.0154	0.57 0.0224	0.75 0.0295	0.96 0.0378	1.22 0.048	1.5 0.0591	0.279 0.011	0.356 0.014	4.19 0.1650	5.33 0.2098	9.78 0.3850	12.45 0.4902	0.229 0.009
800 31.4961	900 35.4331	0.44 0.0173	0.64 0.0252	0.84 0.0331	1.07 0.0421	1.37 0.0539	1.69 0.0665	0.305 0.012	0.381 0.015	4.57 0.1799	5.72 0.2252	10.67 0.4201	13.33 0.5248	0.252 0.01
900 35.4331	1000 39.3701	0.49 0.0193	0.71 0.028	0.93 0.0366	1.19 0.0469	1.52 0.0598	1.86 0.0732	0.356 0.014	0.432 0.017	5.33 0.2100	6.48 0.2551	12.45 0.4902	15.11 0.5949	0.279 0.011

⁽¹⁾This displacement is valid for assembly of tapered bore bearings and is measured starting from a line-to-line fit of the bearing bore to the tapered shaft.
⁽²⁾1:12 Taper used for 222, 223, 230, 231, 232, 233, 239 series. 1:30 Taper used for 240, 241, 242 series. For sleeve mounting, multiply axial displacement values by 1.1 for 1:12 Taper or by 1.05 for 1:30 Taper. For questions on tapered shaft data, consult your Timken engineer.
 NOTE: Axial displacement values apply to solid steel shafts or hollow shafts with bore diameter less than half the shaft diameter. For shaft materials other than steel, or for thin-walled shafts, please consult your Timken engineer.
 NOTE: Tolerance and shaft diameters are shown in the table as variances from nominal bearing bore.

EXAMPLE #1 –

Calculating RIC Reduction Using a Spherical Roller Bearing with Tapered Bore

Given bearing number 22328K C3 (140 mm bore with C3 clearance) is to be mounted on a tapered shaft. Using a set of feeler gages, RIC is measured at (see fig. D-3):

$$RIC = 0.178 \text{ mm (0.007 in.)}$$

Suggested reduction of RIC due to installation = 0.064 mm – 0.089 mm (0.0025 in. – 0.0035 in.), found in table D-5 on page D-10.

Calculate the clearance after mounting (see fig. D-4):

$$0.178 \text{ mm} - 0.076 \text{ mm} = 0.102 \text{ mm } \textit{or}$$

$$(0.007 \text{ in.} - 0.003 \text{ in.} = 0.004 \text{ in.})$$

For this example, the value of 0.076 mm (0.003 in.) was obtained by taking the mid-range value of the upper and lower limits found in the tables on pages D-9 and D-10.

Therefore, the locknut should be tightened until RIC reaches 0.102 mm (0.004 in.).



Fig. D-3. Measure RIC before installation.



Fig. D-4. During mounting, the RIC should be checked at the unloaded roller.

It also should be noted that the value obtained by reading the suggested RIC after installation directly from the table is 0.056 mm (0.0022 in.). This differs from the value calculated in the example. The value taken directly from the table is provided as a minimum value. It is not suggested to use a calculated value that falls below this minimum.

EXAMPLE #2 –

Calculating RIC Reduction Using a Spherical Roller Bearing with Cylindrical Bore

Observations:

- Bearing 22230EM, nominal 150 mm (5.0955 in.) bore and 270 mm (10.6299 in.) O.D., standard class, operating at 1200 RPM.
- Float bearing position so the stationary O.D. should be free to move in SAF housing, with the stabilizing ring removed.
- With shaft/inner ring rotation and the moderate loading 0.09C, the bore should be tight fit.

We can use the nominal fit charts on page D-15 (shaft fit) to help guide our ISO fit selection.

Shaft Fit at 150 mm Bore: ISO p6

From the shaft fit chart at 150 mm nominal bore at p6 (page D-20), the shaft tolerance is nominal +0.043 to +0.068 mm (+0.0017 to +0.0027 in.). Therefore we have the following bore range:

$$\text{max. shaft} = 150.068 \text{ mm (5.0955 in.)}$$

$$\text{min. shaft} = 150.043 \text{ mm (5.0945 in.)}$$

This yields a shaft fit:

$$\begin{aligned} \text{max. fit} &= \text{max. shaft} - \text{min. bore} \\ &= 150.068 - 149.075 \\ &= 0.093 \text{ mm (0.0037 in.) tight} \end{aligned}$$

$$\begin{aligned} \text{min. fit} &= \text{min. shaft} - \text{max. bore} \\ &= 150.043 - 150.000 \\ &= 0.043 \text{ mm (0.0017 in.) tight} \end{aligned}$$

For the primary selection of RIC, the major parameters are the bearing speed and the fits. For our example, we know that the shaft fit is 0.043 mm (0.0017 in.) tight to 0.093 mm (0.0037 in.) tight.

We know the housing fit is loose. We also know that the bearing speed is 1200 RPM or 60 percent of the speed rating.

As a general rule of thumb, we increase the clearance for operating speeds that exceed 70 percent of the speed rating, due to concerns over internal heat generation and thermal growth. In this case, we are at 60 percent of the speed rating, so normal clearance, ISO CO or the SAF standard C3, can be selected.

Observing the RIC chart on page D-9, we find for 150 mm nominal bore at CO, the RIC will be 0.110 mm to 0.170 mm (0.0043 in. to 0.0067 in.). We also note that the minimum recommended RIC (installed) is 0.056 mm (0.0022 in.).

Also from page D-9, we note that we get an approximate reduction of RIC that is 80 percent of interference fit on a solid housing. Since we have a loose housing fit, there will be no RIC reduction from that fit.

Shaft fit RIC reductions and clearance:

For a 150 mm nominal bore at C3, the RIC will be 0.115 to 0.165 mm (0.0045 to 0.0065 in.). Recalculating shaft fit RIC reduction and clearance:

$$\begin{aligned} \text{max. clearance} &= \text{max. RIC} - \text{min. fit reduction} \\ &= 0.165 - 0.034 = 0.131 \text{ mm (0.0052 in.)} \end{aligned}$$

$$\begin{aligned} \text{min. clearance} &= \text{min. RIC} - \text{max. fit reduction} \\ &= 0.115 - 0.074 = 0.041 \text{ mm (0.0016 in.)} \end{aligned}$$

Since the minimum mounted clearance is less than the minimum suggested RIC of 0.056 mm (0.0022 in.), the C3 RIC clearance limit needs to be reevaluated.

INSTALLATION

When using a tight fit inner ring, the method of assembly will depend on whether the bearing has a cylindrical or tapered bore.

CLEANLINESS

- Choose a clean environment, free from dust and moisture.
- The installer should make every effort to ensure cleanliness by use of protective screens and clean cloths.

PLAN THE WORK

- Know your plans in advance and have the necessary tools at hand. This reduces the amount of time for the job and decreases the chance for dirt to get into the bearing.

INSPECTION AND PREPARATION

- All component parts of the machine should be on hand and thoroughly cleaned before proceeding.
- Housings should be cleaned, including blowing out the oil holes.
- Do not use air hose on bearings.
- If blind holes are used, insert a magnetic rod to remove metal chips that might be lodged there during fabrication.
- Shaft shoulders and spacer rings contacting the bearing should be square with the shaft axis.
- The shaft fillet must be small enough to clear the radius of the bearing.
- On original installations, all component parts should be checked against the detail specification prints for dimensional accuracy. Shaft and housing should be carefully checked for size and form (roundness, etc.).

SHAFT AND HOUSING FINISH

- Shaft surfaces on which the bearing will be mounted must be clean and free from nicks and burrs.
- For applications with stationary housing and rotating shaft, it is suggested that the bearing seat on the shaft be ground to 1.6 µm (65 µin.) Ra maximum.
- If it is impractical to use a ground finish, a machined finish of 3.2 µm (125 µin.) Ra is acceptable in many cases, but the amount of interference fit should be slightly increased.

INSTALLING CYLINDRICAL BORE BEARINGS

Heat expansion method

- Most applications require a tight interference fit on the shaft.
- Mounting is simplified by heating the bearing to expand it sufficiently to slide easily onto the shaft.
- Two methods of heating are commonly used:
 1. Tank of heated oil.
 - Accomplished by heating the bearing in a tank of oil that has a high flash point (see fig. D-5).
 - The oil temperature should not be allowed to exceed 121° C (250° F). A temperature of 93° C (200° F) is sufficient for most applications.
 - The bearing should be heated for 20 or 30 minutes, or until it is expanded sufficiently to slide onto the shaft easily.
 - The oil bath is shown in fig. D-5. The bearing should not be in direct contact with the heat source.
 - The usual arrangement is to have a screen several inches from the bottom of the tank. Small support blocks separate the bearing from the screen.
 - It is important to keep the bearing away from any localized high-heat source that may raise its temperature excessively, resulting in ring hardness reduction.
 - Flame-type burners are commonly used. An automatic device for temperature control is desirable.
 - If safety regulations prevent the use of an open heated oil bath, a mixture of 15 percent soluble-oil water may be used. This mixture may be heated to a maximum of 93° C (200° F) without being flammable.



WARNING

Failure to observe the following warnings could create a risk of death or serious injury.

Proper maintenance and handling practices are critical. Always follow installation instructions and maintain proper lubrication.



CAUTION

Failure to follow these cautions could create a risk of injury.

Remove oil or rust inhibitor from parts before heating, to avoid fire and fumes.

2. Induction heating.

- The induction heating process can be used for mounting bearings.
- Induction heating is rapid. Care must be taken to prevent bearing temperature from exceeding 93° C (200° F).
- Trial runs with the unit and bearing are usually necessary to obtain proper timing.
- Thermal crayons melted at predetermined temperatures or thermal gun can be used to check the bearing temperature.
- While the bearing is hot, it should be positioned squarely against the shoulder.
- Lockwashers and locknuts or clamping plates are then installed to hold the bearing against the shoulder of the shaft.
- As the bearing cools, the locknut or clamping plate should be tightened.
- For more information see the Timken Spherical Roller Bearing Catalog (order no. 10446), found on www.timken.com.

NOTE

Never use steam or hot water when cleaning the bearings because these methods can create rust or corrosion.

Never expose any surface of a bearing to the flame of a torch.

Do not heat bearing beyond 149° C (300° F).

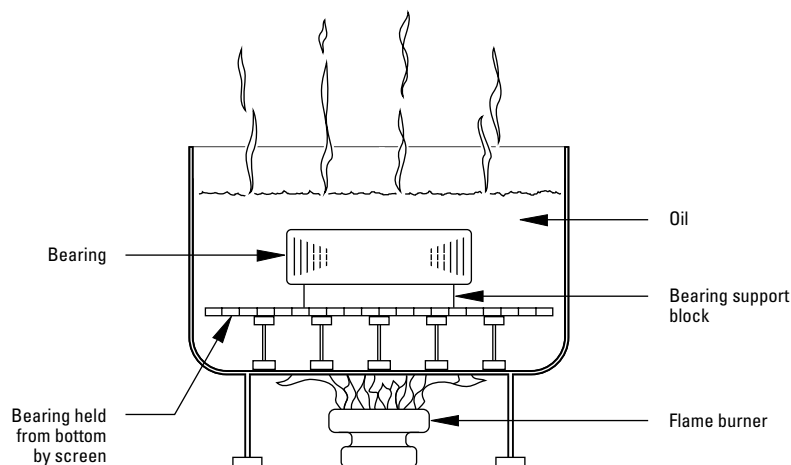

Fig. D-5. Heat expansion method.

Arbor press method

- An alternate method of mounting, generally used only on smaller size bearings, is to press the bearing onto the shaft or into the housing. This can be done by using an arbor press and a mounting tube as shown in fig. D-6.
- The tube should be made from soft steel with an inside diameter slightly larger than the shaft.
- The O.D. of the tube should not exceed the shaft backing diameter given in the Timken Spherical Roller Bearing Catalog (order no. 10446), found on www.timken.com.
- The tube should be faced square at both ends. It should be thoroughly clean inside and out, and long enough to clear the end of the shaft after the bearing is mounted.
- If the outer ring is being pressed into the housing, the O.D. of the mounting tube should be slightly smaller than the housing bore. The I.D. should not be less than the suggested housing backing diameter in the table of dimensions available in the Timken Spherical Roller Bearing Catalog (order no. 10446), found on www.timken.com.
- Coat the shaft with a light machine oil to reduce the force needed for a press fit.
- Carefully place the bearing on the shaft, making sure it is square with the shaft axis.
- Apply steady pressure from the arbor ram to drive the bearing firmly against the shoulder.

NOTE

Never attempt a press fit on a shaft by applying pressure to the outer ring or a press fit in a housing by applying pressure to the inner ring.

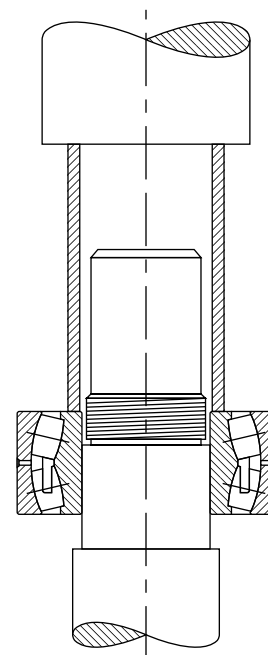

Fig. D-6. Arbor press method.

Mounting tapered bore spherical roller bearings

- Use a feeler gage with the thinnest blade of 0.038 mm (0.0015 in.).
- Place the bearing in an upright position with the inner and outer ring faces parallel.
- Place thumbs on the inner ring bore and oscillate the inner ring the distance of two or three roller spacings.
- Position the individual roller assemblies so that a roller is at the top of the inner ring on both sides of the bearing.
- With the roller in the correct position, insert a thin blade of the feeler gage between the roller and the outer ring, as shown in fig. D-7.
- Move the feeler gage carefully along the top roller between the roller and outer ring raceway. Repeat this procedure using thicker feeler gage blades until one is found that will not go through.
- The blade thickness that preceded the no-go blade is a measure of RIC before installation.
- Start the mounting procedure by lubricating the tapered shaft with a light coat of machine oil.
- Slide the bearing onto the shaft as far as it will go by hand.
- As the locknut is tightened, the interference fit builds up, resulting in expansion of the inner ring.
- Periodically measure to keep track of the reduction in RIC.
- Continue the procedure until the proper amount of reduction is obtained. Do not exceed suggested amount of reduction.
- As a final check, make sure the remaining RIC equals or exceeds the minimum mounted clearance shown in table D-5 on page D-10.
- During mounting, the RIC should be checked at the unloaded roller. If this is at the bottom, make sure that the roller is raised to seat firmly at the inboard position of the inner ring.
- When the suggested amount of RIC reduction has been accomplished, the bearing is properly fitted.
- Complete the procedure by peening the lockwasher tang into the locknut slot or securing the lockplate.



Fig. D-7. Measure RIC before installation.

SHAFT FITS FOR CYLINDRICAL BORE BEARINGS

This chart is a guideline for specifying shaft fits related to particular operating conditions. Please contact your Timken engineer for more information.

TABLE D-6. RADIAL SPHERICAL ROLLER BEARING SHAFT FITS

	Conditions	Examples	Shaft Dia.		Tolerance Symbol ⁽¹⁾	Remarks
			mm	in.		
Stationary inner ring load	The inner ring not to be easily displaced on the shaft	Wheel on non-rotating shaft	All diameters		g6	
		Tension pulleys and rope sheaves			h6	
Rotating inner ring load or indeterminate load direction	Light and variable loads $P \leq 0.07C$	Electrical apparatus, machine tools, pumps, ventilators, industrial trucks	over	incl.	k6	In very accurate applications, k5 and m5 are used instead of k6 and m6 respectively.
			18 0.7087	100 3.9370		
			100 3.9370	200 7.8740	m6	
	Normal and heavy loads $P > 0.07C$ $\leq 0.25C$	Applications in general, electrical motors, turbines, pumps, combustion engines, gear transmissions, woodworking machines	18 0.7087	65 2.5590	m5	
			65 2.5590	100 3.9370	m6	
			100 3.9370	140 5.5118	n6	
			140 5.5118	280 11.0236	p6	
			280 11.0236	500 19.6850	r6	
	500 19.6850	and up	r7			
	Very heavy loads and shock loads $P > 0.25C$	Journal boxes for locomotives and other heavy rail vehicles, traction motors	18 0.7087	65 2.5590	m6	Bearings with greater clearance than normal must be used.
			65 2.5590	100 3.9370	n6	
			100 3.9370	140 5.5118	p6	
			140 5.5118	200 7.8740	r6	
			200 7.8740	500 19.6850	r7	
	BEARINGS WITH TAPERED BORE AND ADAPTER SLEEVE					
	All loads	Applications in general	All diameters			See tables for Reduction of RIC on pages D-9 and D-10.

⁽¹⁾For solid steel shaft. See tables on pages D-16 through D-21 for tolerance value.
NOTE: Tolerance and shaft diameters are shown in the table as variances from nominal bearing bore.

These charts are guidelines for specifying shaft and housing fits related to particular operating conditions in table D-6 on page D-15.

FITTING PRACTICE TABLES

TABLE D-7. SPHERICAL ROLLER BEARINGS - SHAFT TOLERANCES (CLASSES g6, h5, h6, j5, j6, k5, k6, m5)

Bearing Bore			g6			h6			h5			j5		
Nominal (Max.)		Tolerance ⁽¹⁾	Shaft Dia.			Shaft Dia.			Shaft Dia.			Shaft Dia.		
Over	Incl.		Max.	Min.	Fit	Max.	Min.	Fit	Max.	Min.	Fit	Max.	Min.	Fit
mm	mm	mm	mm	mm	mm	mm	mm	mm	mm	mm	mm	mm	mm	mm
in.	in.	in.	in.	in.	in.	in.	in.	in.	in.	in.	in.	in.	in.	in.
30.000	50.000	-0.014	-0.009	-0.025	0.003T	0.000	-0.016	0.012T	-	-	-	+0.006	-0.005	0.018T
1.1811	1.9685	-0.0006	-0.0004	-0.0010	0.0010L	0.0000	-0.0006	0.0006L				+0.0002	-0.0002	0.0002L
					0.0001T			0.0005T						0.0007T
50.000	80.000	-0.015	-0.010	-0.029	0.005T	0.000	-0.019	0.015T	-	-	-	+0.006	-0.007	0.021T
1.9685	3.1496	-0.0006	-0.0004	-0.0011	0.0011L	0.0000	-0.0007	0.0007L				+0.0002	-0.0003	0.0003L
					0.0002T			0.0006T						0.0008T
80.000	120.000	-0.020	-0.012	-0.034	0.008T	0.000	-0.022	0.020T	-	-	-	+0.006	-0.009	0.026T
3.1496	4.7244	-0.0008	-0.0005	-0.0013	0.0013L	0.0000	-0.0009	0.0009L				+0.0002	-0.0004	0.0004L
					0.0003T			0.0008T						0.0010T
120.000	180.000	-0.025	-0.014	-0.039	0.011T	0.000	-0.025	0.025T	-	-	-	+0.007	-0.011	0.032T
4.7244	7.0866	-0.0010	-0.0006	-0.0015	0.0015L	0.0000	-0.0010	0.0010L				+0.0003	-0.0004	0.0004L
					0.0004T			0.0010T						0.0013T
180.000	200.000	-0.030	-0.015	-0.044	0.015T	0.000	-0.029	0.030T	-	-	-	+0.007	-0.013	0.037T
7.0866	7.8740	-0.0012	-0.0006	-0.0017	0.0017L	0.0000	-0.0011	0.0011L				+0.0003	-0.0005	0.0005L
					0.0006T			0.0012T						0.0015T
200.000	225.000	-0.030	-0.015	-0.044	0.015T	0.000	-0.029	0.030T	-	-	-	+0.007	-0.013	0.037T
7.8740	8.8583	-0.0012	-0.0006	-0.0017	0.0017L	0.0000	-0.0011	0.0011L				+0.0003	-0.0005	0.0005L
					0.0006T			0.0012T						0.0015T
225.000	250.000	-0.030	-0.015	-0.044	0.015T	0.000	-0.029	0.030T	-	-	-	+0.007	-0.013	0.037T
8.8583	9.8425	-0.0012	-0.0006	-0.0017	0.0017L	0.0000	-0.0011	0.0011L				+0.0003	-0.0005	0.0005L
					0.0006T			0.0012T						0.0015T
250.000	280.000	-0.035	-0.017	-0.049	0.018T	0.000	-0.032	0.035T	-	-	-	+0.007	-0.016	0.042T
9.8425	11.0236	-0.0014	-0.0007	-0.0019	0.0019L	0.0000	-0.0013	0.0013L				+0.0003	-0.0006	0.0006L
					0.0007T			0.0014T						0.0017T
280.000	315.000	-0.035	-0.017	-0.049	0.018T	0.000	-0.032	0.035T	-	-	-	+0.007	-0.016	0.042T
11.0236	12.4016	-0.0014	-0.0007	-0.0019	0.0019L	0.0000	-0.0013	0.0013L				+0.0003	-0.0006	0.0006L
					0.0007T			0.0014T						0.0017T
315.000	355.000	-0.040	-0.018	-0.054	0.022T	0.000	-0.036	0.040T	-	-	-	+0.007	-0.018	0.047T
12.4016	13.9764	-0.0016	-0.0007	-0.0021	0.0021L	0.0000	-0.0014	0.0014L				+0.0003	-0.0007	0.0007L
					0.0009T			0.0016T						0.0019T

⁽¹⁾Tolerance range is from +0 to value listed.

NOTE: Tolerance and shaft diameters are shown in the table as variances from nominal bearing bore.

These charts are guidelines for specifying shaft and housing fits related to particular operating conditions in table D-6 on page D-15.

j6			k5			k6			m5		
Shaft Dia.		Fit	Shaft Dia.		Fit	Shaft Dia.		Fit	Shaft Dia.		Fit
Max.	Min.		Max.	Min.		Max.	Min.		Max.	Min.	
mm	mm	mm	mm	mm	mm	mm	mm	mm	mm	mm	mm
in.	in.	in.	in.	in.	in.	in.	in.	in.	in.	in.	in.
		0.005L			0.002T			0.002T			0.009T
+0.011	-0.005	0.023T	+0.013	+0.002	0.025T	+0.018	+0.002	0.030T	+0.020	+0.009	0.032T
+0.0004	-0.0002	0.0002L	+0.0005	+0.0001	0.0001T	+0.0007	+0.0001	0.0001T	+0.0008	+0.0004	0.0004T
		0.00085T			0.0010T			0.0012T			0.00125T
		0.007L			0.002T			0.002T			0.011T
+0.012	-0.007	0.027T	+0.015	+0.002	0.030T	+0.021	+0.002	0.036T	+0.024	+0.011	0.039T
+0.0005	-0.0003	0.0003L	+0.0006	+0.0001	0.0001T	+0.0008	+0.0001	0.0001T	+0.0009	+0.0004	0.0004T
		0.0011T			0.0012T			0.0014T			0.0015T
		0.009L			0.003T			0.003T			0.013T
+0.013	-0.009	0.033T	+0.018	+0.003	0.038T	+0.025	+0.003	0.045T	+0.028	+0.013	0.048T
+0.0005	-0.0004	0.0004L	+0.0007	+0.0001	0.0001T	+0.0010	+0.0001	0.0001T	+0.0011	+0.0005	0.0005T
		0.0013T			0.0015T			0.0018T			0.0019T
		0.011L			0.003T			0.003T			0.015T
+0.014	-0.011	0.039T	+0.021	+0.003	0.046T	+0.028	+0.003	0.053T	+0.033	+0.015	0.058T
+0.0006	-0.0004	0.0004L	+0.0008	+0.0001	0.0001T	+0.0011	+0.0001	0.0001T	+0.0013	+0.0006	0.0006T
		0.0016T			0.0018T			0.0021T			0.0023T
		0.013L			0.004T						0.017T
+0.016	-0.013	0.046T	+0.024	+0.004	0.054T	-	-	-	+0.037	+0.017	0.067T
+0.0006	-0.0005	0.0005L	+0.0009	+0.0002	0.0002T				+0.0015	+0.0007	0.0007T
		0.0018T			0.0021T						0.0027T
		0.013L			0.004T						0.017T
+0.016	-0.013	0.046T	+0.024	+0.004	0.054T	-	-	-	+0.037	+0.017	0.067T
+0.0006	-0.0005	0.0005L	+0.0009	+0.0002	0.0002T				+0.0015	+0.0007	0.0007T
		0.0018T			0.0021T						0.0027T
		0.013L			0.004T						0.017T
+0.016	-0.013	0.046T	+0.024	+0.004	0.054T	-	-	-	+0.037	+0.017	0.067T
+0.0006	-0.0005	0.0005L	+0.0009	+0.0002	0.0002T				+0.0015	+0.0007	0.0007T
		0.0018T			0.0021T						0.0027T
		0.016L			0.004T						0.020T
+0.016	-0.016	0.051T	+0.027	+0.004	0.062T	-	-	-	+0.043	+0.020	0.078T
+0.0006	-0.0006	0.0006L	+0.0011	+0.0002	0.0002T				+0.0017	+0.0008	0.0008T
		0.0020T			0.0025T						0.0031T
		0.016L			0.004T						0.020T
+0.016	-0.016	0.051T	+0.027	+0.004	0.062T	-	-	-	+0.043	+0.020	0.078T
+0.0006	-0.0006	0.0006L	+0.0011	+0.0002	0.0002T				+0.0017	+0.0008	0.0008T
		0.0020T			0.0025T						0.0031T
		0.018L			0.004T						0.021T
+0.018	-0.018	0.058T	+0.029	+0.046	0.069T	-	-	-	+0.046	+0.021	0.086T
+0.0007	-0.0007	0.0007L	+0.0011	+0.0002	0.0002T				+0.0018	+0.0008	0.0008T
		0.0023T			0.0027T						0.0034T

⁽¹⁾Tolerance range is from +0 to value listed.

NOTE: Tolerance and shaft diameters are shown in the table as variances from nominal bearing bore.

Continued on next page.



These charts are guidelines for specifying shaft and housing fits related to particular operating conditions in table D-6 on page D-15.

TABLE D-7. SPHERICAL ROLLER BEARINGS - SHAFT TOLERANCES (CLASSES g6, h5, h6, j5, j6, k5, k6, m5) – continued

Bearing Bore			g6			h6			h5			j5		
Nominal (Max.)		Tolerance ⁽¹⁾	Shaft Dia.			Shaft Dia.			Shaft Dia.			Shaft Dia.		
Over	Incl.		Max.	Min.	Fit	Max.	Min.	Fit	Max.	Min.	Fit	Max.	Min.	Fit
mm	mm	mm	mm	mm	mm	mm	mm	mm	mm	mm	mm	mm	mm	mm
in.	in.	in.	in.	in.	in.	in.	in.	in.	in.	in.	in.	in.	in.	in.
355.000	400.000	-0.040			0.054L			0.036L						0.018L
13.9764	15.7480	-0.0016	-0.018	-0.054	0.022T	0.000	-0.036	0.040T	-	-	-	+0.007	-0.018	0.047T
			-0.0007	-0.0021	0.0021L	0.0000	-0.0014	0.0014L				+0.0003	-0.0007	0.0007L
					0.0009T			0.0016T						0.0019T
					0.060L			0.040L						0.020L
400.000	450.000	-0.045	-0.020	-0.060	0.025T	0.000	-0.040	0.045T	-	-	-	+0.007	-0.020	0.052T
15.7480	17.7165	-0.0018	-0.0008	-0.0024	0.0024L	0.0000	-0.0016	0.0016L				+0.0003	-0.0008	0.0008L
					0.0010T			0.0018T						0.0021T
					0.060L			0.040L						0.020L
450.000	500.000	-0.045	-0.020	-0.060	0.025T	0.000	-0.040	0.045T	-	-	-	+0.007	-0.020	0.052T
17.7165	19.6850	-0.0018	-0.0008	-0.0024	0.0024L	0.0000	-0.0016	0.0016L				+0.0003	-0.0008	0.0008L
					0.0010T			0.0018T						0.0020T

⁽¹⁾Tolerance range is from +0 to value listed.

NOTE: Tolerance and shaft diameters are shown in the table as variances from nominal bearing bore.

These charts are guidelines for specifying shaft and housing fits related to particular operating conditions in table D-6 on page D-15.

j6			k5			k6			m5		
Shaft Dia.		Fit	Shaft Dia.		Fit	Shaft Dia.		Fit	Shaft Dia.		Fit
Max.	Min.		Max.	Min.		Max.	Min.		Max.	Min.	
mm	mm	mm	mm	mm	mm	mm	mm	mm	mm	mm	mm
in.	in.	in.	in.	in.	in.	in.	in.	in.	in.	in.	in.
		0.018L			0.004T						0.021T
+0.018	-0.018	0.058T	+0.029	+0.004	0.069T	-	-	-	+0.046	+0.021	0.086T
+0.0007	-0.0007	0.0007L	+0.0011	+0.0002	0.0002T				+0.0018	+0.0008	0.0008T
		0.0023T			0.0027T						0.0034T
		0.020L			0.005T						0.023T
+0.020	-0.020	0.065T	+0.032	+0.005	0.077T	-	-	-	+0.050	+0.023	0.095T
+0.0008	-0.0008	0.0008L	+0.0013	+0.0002	0.0002T				+0.0020	+0.0009	0.0009T
		0.0026T			0.0031T						0.0037T
		0.020L			0.005T						0.023T
+0.020	-0.020	0.065T	+0.032	+0.005	0.077T	-	-	-	+0.050	+0.023	0.095T
+0.0008	-0.0008	0.0008L	+0.0013	+0.0002	0.0002T				+0.0020	+0.0009	0.0009T
		0.0026T			0.0031T						0.0037T

⁽¹⁾Tolerance range is from +0 to value listed.

NOTE: Tolerance and shaft diameters are shown in the table as variances from nominal bearing bore.



These charts are guidelines for specifying shaft and housing fits related to particular operating conditions in table D-6 on page D-15.

TABLE D-8. SPHERICAL ROLLER BEARINGS - SHAFT TOLERANCES (CLASSES m6, n6, p6, r6, r7)

Bearing Bore			m6			n6			p6			r6			r7		
Nominal (Max.)		Tolerance ⁽¹⁾	Shaft Dia.			Shaft Dia.			Shaft Dia.			Shaft Dia.			Shaft Dia.		
Over	Incl.		Max.	Min.	Fit	Max.	Min.	Fit	Max.	Min.	Fit	Max.	Min.	Fit	Max.	Min.	Fit
mm	mm	mm	mm	mm	mm	mm	mm	mm	mm	mm	mm	mm	mm	mm	mm	mm	mm
in.	in.	in.	in.	in.	in.	in.	in.	in.	in.	in.	in.	in.	in.	in.	in.	in.	in.
30.000	50.000	-0.014	+0.025	+0.009	0.037T												
1.1811	1.9685	-0.0006	+0.0010	+0.0004	0.0004T	-	-	-	-	-	-	-	-	-	-	-	-
					0.0145T												
50.000	80.000	-0.015	+0.030	+0.011	0.045T	+0.039	+0.020	0.054T									
1.9685	3.1496	-0.0006	+0.0012	+0.0004	0.0004T	+0.0015	+0.0008	0.0008T	-	-	-	-	-	-	-	-	-
					0.0018T			0.0021T									
80.000	120.000	-0.020	+0.035	+0.013	0.055T	+0.045	+0.023	0.065T	+0.059	+0.037	0.079T						
3.1496	4.7244	-0.0008	+0.0014	+0.0005	0.0005T	+0.0018	+0.0009	0.0009T	+0.0023	+0.0015	0.0015T	-	-	-	-	-	-
					0.0022T			0.0026T			0.0031T						
120.000	180.000	-0.025	+0.040	+0.015	0.065T	+0.052	+0.027	0.077T	+0.068	+0.043	0.093T	+0.090	+0.065	0.115T			
4.7244	7.0866	-0.0010	+0.0016	+0.0006	0.0006T	+0.0020	+0.0011	0.0011T	+0.0027	+0.0017	0.0017T	+0.0035	+0.0026	0.0026T	-	-	-
					0.0026T			0.0030T			0.0037T			0.0045T			
180.000	200.000	-0.030	+0.046	+0.017	0.076T	+0.060	+0.031	0.090T	+0.079	+0.050	0.109T	+0.106	+0.077	0.136T			
7.0866	7.8740	-0.0012	+0.0018	+0.0007	0.0007T	+0.0024	+0.0012	0.0012L	+0.0031	+0.0020	0.0020T	+0.0042	+0.0030	0.0030T	-	-	-
					0.0030T			0.0036T			0.0043T			0.0054T			
200.000	225.000	-0.030	+0.046	+0.017	0.076T	+0.060	+0.031	0.090T	+0.079	+0.050	0.109T	+0.109	+0.080	0.139T	+0.126	+0.080	0.156T
7.8740	8.8583	-0.0012	+0.0018	+0.0007	0.0007T	+0.0024	+0.0012	0.0012L	+0.0031	+0.0020	0.0020T	+0.0043	+0.0031	0.0031T	+0.0050	+0.0031	0.0031T
					0.0030T			0.0036T			0.0043T			0.0055T			0.0062T
225.000	250.000	-0.030	+0.046	+0.017	0.076T	+0.060	+0.031	0.090T	+0.079	+0.050	0.109T	+0.113	+0.084	0.143T	+0.130	+0.084	0.160T
8.8583	9.8425	-0.0012	+0.0018	+0.0007	0.0007T	+0.0024	+0.0012	0.0012L	+0.0031	+0.0020	0.0020T	+0.0044	+0.0033	0.0033T	+0.0051	+0.0033	0.0033T
					0.0030T			0.0036T			0.0043T			0.0056T			0.0063T
250.000	280.000	-0.035	+0.052	+0.020	0.087T	+0.066	+0.034	0.101T	+0.088	+0.056	0.123T	+0.126	+0.094	0.161T	+0.146	+0.094	0.181T
9.8425	11.0236	-0.0014	+0.0020	+0.0008	0.0008T	+0.0026	+0.0013	0.0013T	+0.0035	+0.0022	0.0022T	+0.0050	+0.0037	0.0037T	+0.0057	+0.0037	0.0037T
					0.0034T			0.0040T			0.0049T			0.0064T			0.0071T
280.000	315.000	-0.035	+0.052	+0.020	0.087T	+0.066	+0.034	0.101T	+0.088	+0.056	0.123T	+0.130	+0.098	0.165T	+0.150	+0.098	0.185T
11.0236	12.4016	-0.0014	+0.0020	+0.0008	0.0008T	+0.0026	+0.0013	0.0013T	+0.0035	+0.0022	0.0022T	+0.0051	+0.0039	0.0039T	+0.0059	+0.0039	0.0039T
					0.0034T			0.0040T			0.0049T			0.0065T			0.0073T
315.000	355.000	-0.040	+0.057	+0.021	0.097T	+0.073	+0.037	0.113T	+0.098	+0.062	0.138T	+0.144	+0.108	0.184T	+0.165	+0.108	0.205T
12.4016	13.9764	-0.0016	+0.0022	+0.0008	0.0008T	+0.0029	+0.0015	0.0015T	+0.0039	+0.0024	0.0024T	+0.0057	+0.0043	0.0043T	+0.0065	+0.0043	0.0043T
					0.0038T			0.0045T			0.0055T			0.0073T			0.0081T

⁽¹⁾Tolerance range is from +0 to value listed.

NOTE: Tolerance and shaft diameters are shown in the table as variances from nominal bearing bore.

Continued on next page.

These charts are guidelines for specifying shaft and housing fits related to particular operating conditions in table D-6 on page D-15.

Continued from previous page.

Bearing Bore			m6			n6			p6			r6			r7		
Nominal (Max.)		Tolerance ⁽¹⁾	Shaft Dia.		Fit	Shaft Dia.		Fit	Shaft Dia.		Fit	Shaft Dia.		Fit	Shaft Dia.		Fit
Over	Incl.		Max.	Min.		Max.	Min.		Max.	Min.		Max.	Min.		Max.	Min.	
mm	mm	mm	mm	mm	mm	mm	mm	mm	mm	mm	mm	mm	mm	mm	mm	mm	mm
in.	in.	in.	in.	in.	in.	in.	in.	in.	in.	in.	in.	in.	in.	in.	in.	in.	in.
355.000	400.000	-0.040	-	-	-	0.037T			0.062T			0.114T			0.114T		
						+0.073	+0.037	0.113T	+0.098	+0.062	0.138T	+0.150	+0.114	0.190T	+0.171	+0.114	0.211T
13.9764	15.7480	-0.0016	-	-	-	+0.0029	+0.0015	0.0015T	+0.0039	+0.0024	0.0024T	+0.0059	+0.0045	0.0045T	+0.0067	+0.0045	0.0045T
								0.0045T			0.0055T			0.0075T			0.0083T
400.000	450.000	-0.045	-	-	-	0.040T			0.068T			0.126T			0.126T		
						+0.080	+0.040	0.125T	+0.108	+0.068	0.153T	+0.166	+0.126	0.211T	+0.189	+0.126	0.234T
15.7480	17.7165	-0.0018	-	-	-	+0.0031	+0.0016	0.0016T	+0.0043	+0.0027	0.0027T	+0.0065	+0.0050	0.0050T	+0.0074	+0.0050	0.0050T
								0.0049T			0.0061T			0.0083T			0.0092T
450.000	500.000	-0.045	-	-	-	0.040T			0.068T			0.132T			0.132T		
						+0.080	+0.040	0.125T	+0.108	+0.068	0.153T	+0.172	+0.132	0.217T	+0.195	+0.132	0.240T
17.7165	19.6850	-0.0018	-	-	-	+0.0031	+0.0016	0.0016T	+0.0043	+0.0027	0.0027T	+0.0068	+0.0052	0.0052T	+0.0077	+0.0052	0.0052T
								0.0049T			0.0061T			0.0086T			0.0095T

⁽¹⁾Tolerance range is from +0 to value listed.

NOTE: Tolerance and shaft diameters are shown in the table as variances from nominal bearing bore.





SAF LUBRICATION

To help maintain a bearing's antifriction characteristics, lubrication is needed to:

- Minimize rolling resistance caused by deformation of the rolling elements and raceway under load by separating the mating surfaces.
- Minimize sliding friction occurring between rolling elements, raceways and cage.
- Transfer heat (with oil lubrication).
- Protect from corrosion and, with grease lubrication, from contaminant ingress.

SAF Lubrication D-24
 Grease Lubrications for Bearing/Housing Assemblies D-32
 General-Purpose Industrial Grease D-32



SAF LUBRICATION

The wide range of bearing types and operating conditions precludes any simple, all-inclusive statement or guideline allowing the selection of the proper lubricant. At the design level, the first consideration is whether oil or grease is best for the particular operation. The advantages of oil and grease are outlined in the table below. When heat must be carried away from the bearing, oil must be used. It is almost always preferred for very high-speed applications. Timken SAF housings are designed to allow lubrication via grease, oil bath, or oil circulation.

TABLE D-10. ADVANTAGES OF OIL AND GREASE

Oil	Grease
Carries heat away from the bearings	Simplifies seal design and acts as a sealant
Carries away moisture and particulate matter	Permits prelubrication of sealed or shielded bearings
Easily controlled lubrication	Generally requires less frequent lubrication

European REACH compliance

Timken-branded lubricants, greases and similar products sold in stand-alone containers or delivery systems are subject to the European REACH (Registration, Evaluation, Authorization and Restriction of Chemicals) directive. For import into the European Union, Timken can sell and provide only those lubricants and greases that are registered with ECHA (European Chemical Agency). For further information, please contact your Timken engineer.

OIL LUBRICATION

Oils used for bearing lubrication should be high-quality mineral oils or synthetic oils with similar properties. Selection of the proper type of oil depends on bearing speed, load, operating temperature and lubrication method. Some features and advantages of oil lubrication, in addition to the above are:

- Oil is a better lubricant for high speeds or high temperatures. It can be cooled to help reduce bearing temperature.
- It is easier to handle and control the amount of lubricant reaching the bearing. It is harder to retain in the bearing. Lubricant losses may be higher than with grease.
- Oil can be introduced to the bearing in many ways, such as drip-feed, wick-feed, pressurized circulating systems, oil bath or air-oil mist. Each is suited for certain types of applications.
- Oil is easier to keep clean for recirculating systems.

Oil may be introduced to the bearing housing in many ways.

The most common systems are:

- **Oil bath.** The SAF housing is designed to provide a sump through which the rolling elements of the bearing will pass. Generally, the oil level should be no higher than the center point of the lowest rolling element. If speed is high, lower oil levels should be used to reduce churning. Gages or controlled elevation drains are used to achieve and maintain the proper oil level.
- **Circulating system.** This system has the advantages of:
 - An adequate supply of oil for both cooling and lubrication.
 - Metered control of the quantity of oil delivered to each bearing.
 - Removal of contaminants and moisture from the bearing by flushing action.
 - Suitability for multiple bearing installations.
 - Large reservoir, which reduces deterioration. Increased lubricant life provides economical efficiency.
 - Incorporation of oil-filtering devices.
 - Positive control to deliver the lubricant where needed.
 - A typical circulating oil system consists of an oil reservoir, pump, piping and filter. A heat exchange may be required.
- **Oil-mist lubrication.** Oil-mist lubrication systems are used in high-speed, continuous-operation applications. This system permits close control of the amount of lubricant reaching the bearings. The oil may be metered, atomized by compressed air and mixed with air, or it may be picked up from a reservoir using a venturi effect. In either case, the air is filtered and supplied under sufficient pressure to assure adequate lubrication of the bearings. Control of this type of lubrication system is accomplished by monitoring the operating temperatures of the bearings being lubricated. The continuous passage of the pressurized air and oil through the labyrinth seals used in the system prevents the entrance of contaminants from the atmosphere to the system. The successful operation of this type of system is based upon the following factors:
 - Proper location of the lubricant entry ports in relation to the bearings being lubricated.
 - Avoidance of excessive pressure drops across void spaces within the system.
 - Proper air pressure and oil quantity ratio to suit the particular application.
 - Adequate exhaust of the air-oil mist after lubrication has been accomplished.

To ensure wetting of the bearings, and to prevent possible damage to the rolling elements and rings, it is imperative that the oil-mist system be turned on for several minutes before the equipment is started. The importance of wetting the bearing before starting cannot be overstated, and it also has particular significance for equipment that has been idled for extended periods of time.

Lubricating oils are commercially available in many forms for automotive, industrial, aircraft and other uses. Oils are classified as either petroleum types (refined from crude oil) or synthetic types (produced by chemical synthesis).

PETROLEUM OILS

Petroleum oils are made from a petroleum hydrocarbon derived from crude oil, with additives to improve certain properties. Petroleum oils are used for nearly all oil-lubricated applications of bearings.

SYNTHETIC OILS

Synthetic oils cover a broad range of categories and include polyalphaolefins, silicones, polyglycols and various esters. In general, synthetic oils are less prone to oxidation and can operate at extreme hot or cold temperatures. Physical properties, such as pressure-viscosity coefficients, tend to vary between oil types; use caution when making oil selections.

The polyalphaolefins (PAO) have a hydrocarbon chemistry that parallels petroleum oil both in chemical structures and pressure-viscosity coefficients. Therefore, PAO oil is mostly used in the oil-lubricated applications of bearings when severe temperature environments (hot and cold) are encountered or when extended lubricant life is required.

The silicone, ester and polyglycol oils have an oxygen-based chemistry that is structurally quite different from petroleum oils and PAO oils. This difference has a profound effect on its physical properties where pressure-viscosity coefficients can be lower compared to mineral and PAO oils. This means that these types of synthetic oils may actually generate a smaller elastohydrodynamic (EHD) film thickness than a mineral or PAO oil of equal viscosity at operating temperature. Reductions in bearing fatigue life and increases in bearing wear could result from this reduction of lubricant film thickness.

VISCOSITY

The selection of oil viscosity for any bearing application requires consideration of several factors: load, speed, bearing setting, type of oil and environmental factors. Since oil viscosity varies inversely with temperature, a viscosity value must always be stated with the temperature at which it was determined. High-viscosity oil is used for low-speed or high-ambient-temperature applications. Low-viscosity oil is used for high-speed or low-ambient-temperature applications.

There are several classifications of oils based on viscosity grades. The most familiar are the Society of Automotive Engineers (SAE) classifications for automotive engine and gear oils. The American Society for Testing and Materials (ASTM) and the International Organization for Standardization (ISO) have adopted standard viscosity grades for industrial fluids. Fig. D-8 shows the viscosity comparisons of ISO/ASTM with SAE classification systems at 40° C (104° F).

VISCOSITY CLASSIFICATION COMPARISON

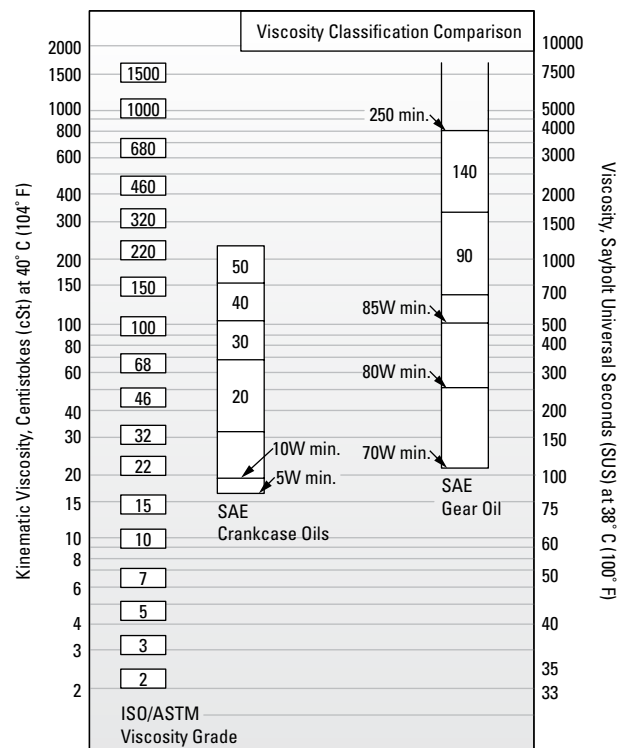

Fig. D-8. Comparison between ISO/ASTM grades (ISO 3448/ASTM D2442) and SAE grades (SAE J 300-80 for crankcase oils, SAE J 306-81 for axle and manual transmission oils).

⚠ WARNING

Failure to observe the following warnings could create a risk of death or serious injury.

Proper maintenance and handling practices are critical. Always follow installation instructions and maintain proper lubrication.

The ASTM/ISO viscosity grade system for industrial oils is depicted in fig. D-9 below.

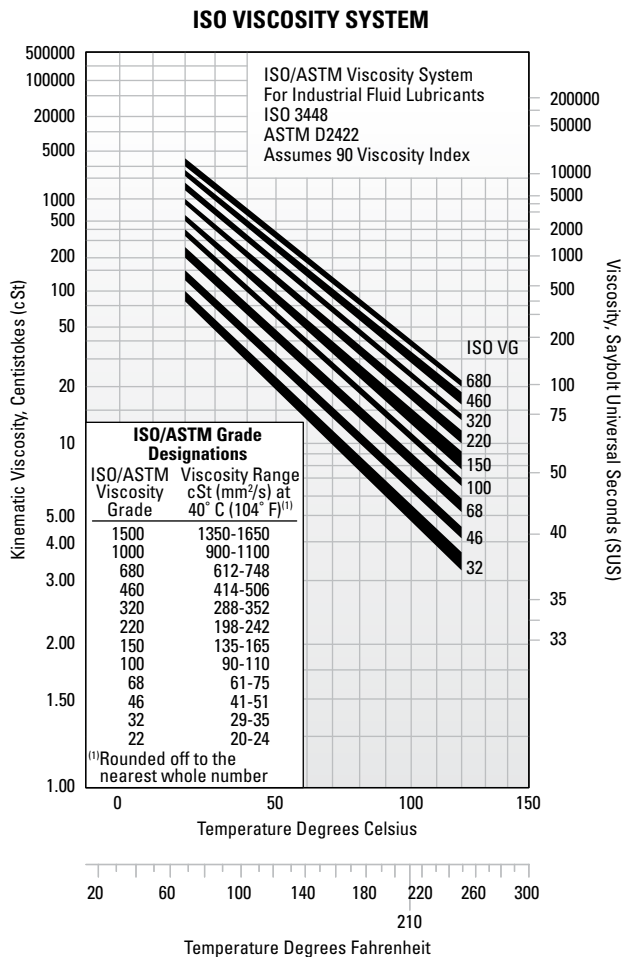

Fig. D-9. Viscosity grade system for industrial oils.

TYPICAL BEARING LUBRICATION OILS

In this section, the properties and characteristics of lubricants for typical roller bearing applications are listed. These general characteristics are derived from successful performance in applications across all industries.

General-purpose rust and oxidation inhibited oil

General-purpose rust and oxidation (R&O) inhibited oils are the most common type of industrial lubricant (see table D-11). They are used to lubricate Timken® bearings in all types of industrial applications where conditions requiring special considerations do not exist.

TABLE D-11. SUGGESTED GENERAL-PURPOSE R&O INHIBITED OIL PROPERTIES

Properties	
Base stock	Solvent-refined, high viscosity-index petroleum oil
Additives	Corrosion and oxidation inhibitors
Viscosity index	80 min.
Pour point	-10° C max. (14° F)
Viscosity grades	ISO/ASTM 32 through 220

Some low-speed and/or high-ambient-temperature applications require the higher viscosity grades. High-speed and/or low-temperature applications require the lower viscosity grades.

Industrial extreme-pressure (EP) gear oil

Extreme-pressure gear oils are used to lubricate Timken bearings in most types of heavily loaded industrial equipment (see table D-12). They should be capable of withstanding abnormal shock loads that are common in heavy-duty equipment.

TABLE D-12. SUGGESTED INDUSTRIAL EP GEAR OIL PROPERTIES

Properties	
Base stock	Solvent-refined, high viscosity-index petroleum oil
Additives	Corrosion and oxidation inhibitors Extreme-pressure (EP) additive ⁽¹⁾ - 15.8 kg (35 lb.) min.
Viscosity index	80 min.
Pour point	-10° C max. (14° F)
Viscosity grades	ISO/ASTM 100, 150, 220, 320, 460

⁽¹⁾ASTM D 2782

Industrial EP gear oils should be composed of a highly refined petroleum oil-based stock plus appropriate inhibitors and additives. They should not contain materials that are corrosive or abrasive to bearings. The inhibitors should provide long-term protection from oxidation and protect the bearing from corrosion in the presence of moisture. The oils should resist foaming in service and have good water-separation properties. An EP additive protects against scoring under boundary-lubrication conditions. The viscosity grades suggested represent a wide range. High-temperature and/or slow-speed applications generally require the higher viscosity grades. Low temperatures and/or high speeds require the use of lower viscosity grades.

GREASE LUBRICATION

Grease lubrication is generally applicable to low-to-moderate speed applications that have operating temperatures within the limits of the grease. There is no universal antifriction bearing grease. Each grease has limiting properties and characteristics.

Greases consist of a base oil, a thickening agent and additives. Conventionally, bearing greases have consisted of petroleum base oils thickened to the desired consistency by some form of metallic soap. More recently synthetic base oils have been used with organic and inorganic thickeners. Table D-13 summarizes the composition of typical lubricating greases.

TABLE D-13. COMPOSITION OF GREASES

Base Oil	+	Thickening Agents	+	Additives	=	Lubricating Grease
Mineral oil		Soaps and complex soaps		Rust inhibitors		
Synthetic hydrocarbon		lithium, aluminum, barium, calcium		Dyes		
Esters		Non-Soap (inorganic)		Tactifiers		
Perfluorinated oil		microgel (clay), carbon black, silica-gel, PTFE		Metal deactivates		
Silicone		Non-Soap (organic)		Oxidation inhibitors		
		Urea compounds		Anti-wear EP		

Calcium- and aluminum-based greases have excellent water resistance and are used in industrial applications where water ingress is an issue. Lithium-based greases are multi-purpose and are used in industrial applications and wheel bearings.

Synthetic base oils such as esters, organic esters and silicones used with conventional thickeners and additives typically have higher maximum operating temperatures than petroleum-based greases. Synthetic greases can be designed to operate in temperatures from -73° C (-100° F) to 288° C (550° F).

In table D-14 are the general characteristics of common thickeners used with petroleum base oils.

Use of the thickeners in table D-14 with synthetic hydrocarbon or ester base oils increases the maximum operating temperature by approximately 10° C (50° F).

Using polyurea as a thickener for lubricating fluids is one of the most significant lubrication developments in more than 30 years. Polyurea grease performance is outstanding in a wide range of bearing applications.

CONSISTENCY

Greases may vary in consistency from semi-fluids that are hardly thicker than a viscous oil to solid grades almost as hard as a soft wood.

Consistency is measured by a penetrometer in which a standard weighted cone is dropped into the grease. The distance the cone penetrates (measured in tenths of a millimeter in a specific time) is the penetration number.

The National Lubricating Grease Institute (NLGI) classification of grease consistency is shown in table D-15 below:

TABLE D-14. GENERAL CHARACTERISTICS OF THICKENERS USED WITH PETROLEUM-BASED OILS

Thickener	Typical Dropping Point		Maximum Temperature		Typical Water Resistance
	°C	°F	°C	°F	
Lithium soap	193	380	121	250	Good
Lithium complex	260+	500+	149	300	Good
Aluminum complex	249	480	149	300	Excellent
Calcium sulfonate	299	570	177	350	Excellent
Polyurea	260	500	149	300	Good

TABLE D-15. NLGI CLASSIFICATIONS

NLGI Grease Grades	Penetration No.
0	355-385
1	310-340
2	265-295
3	220-250
4	175-205
5	130-160
6	85-115

Grease consistency is not fixed; it normally becomes softer when sheared or worked. In the laboratory, this working is accomplished by forcing a perforated plate up and down through a closed container of grease. This working does not compare with the violent shearing action that takes place in a bearing and does not necessarily correlate with actual performance.



LOW TEMPERATURES

Starting torque in a grease-lubricated bearing at low temperatures can be critical. Some greases may function adequately as long as the bearing is operating, but resistance to initial movement may be excessive. In certain smaller machines, starting may be impossible when very cold. Under such operating circumstances, greases containing low-temperature characteristic oils are generally required.

If the operating temperature range is wide, synthetic greases offer advantages. Synthetic greases are available to provide very low starting and running torque at temperatures as low as -73° C (-100° F). In certain instances, these greases perform better in this respect than oil.

An important point concerning lubricating greases is that the starting torque is not necessarily a function of the consistency or the channel properties of the grease. Starting torque is more a function of the individual rheological properties of a particular grease and is best evaluated by application experience.

HIGH TEMPERATURES

The high temperature limit for lubricating greases is generally a function of the thermal and oxidation stability of the fluid and the effectiveness of the oxidation inhibitors. Grease temperature ranges are defined by both the dropping point of the grease thickener and composition of the base oil. Table D-16 shows the temperature ranges of various base oils used in grease formulations.

A rule of thumb, developed from years of testing grease-lubricated bearings, indicates that grease life is halved for every 10° C (50° F) increase in temperature. For example, if a particular grease provides 2000 hours of life at 90° C (194° F), by raising the temperature to 100° C (212° F), reduction in life to approximately 1000 hours would result. On the other hand, 4000 hours could be expected by lowering the temperature to 80° C (176° F).

Thermal stability, oxidation resistance and temperature limitations must be considered when selecting greases for high-temperature applications. In non-relubricatable applications, highly refined mineral oils or chemically stable synthetic fluids are required as the oil component of greases for operation at temperatures above 121° C (250° F).

TABLE D-16. TEMPERATURE RANGES FOR BASE OILS USED IN LUBRICATING GREASES

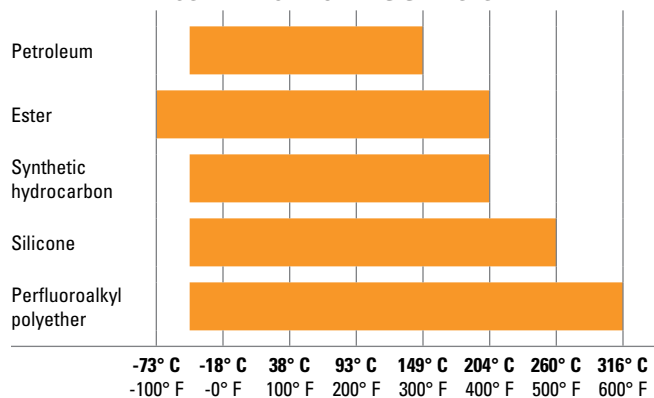

CONTAMINATION

Abrasive Particles

When roller bearings operate in a clean environment, the primary cause of damage is the eventual fatigue of the surfaces where rolling contact occurs. However, when particle contamination enters the bearing system, it is likely to cause damage such as bruising, which can shorten bearing life.

When dirt from the environment or metallic wear debris from some component in the application are allowed to contaminate the lubricant, wear can become the predominant cause of bearing damage. If bearing wear becomes significant, changes will occur to critical bearing dimensions that could adversely affect machine operation.

Bearings operating in a contaminated lubricant exhibit a higher initial rate of wear than those running in an uncontaminated lubricant. With no further contaminant ingress, this wear rate quickly diminishes. The contamination particles are reduced in size as they pass through the bearing contact area during normal operation.

Water

Water and moisture can be particularly conducive to bearing damage. Lubricating greases may provide a measure of protection from this contamination. Certain greases, such as calcium and aluminum-complex, are highly water-resistant.

Sodium-soap greases are water-soluble and should not be used in applications involving water.

Either dissolved or suspended water in lubricating oils can exert a detrimental influence on bearing fatigue life. Water can cause bearing etching that also can reduce bearing fatigue life. The exact mechanism by which water lowers fatigue life is not fully understood. It has been suggested that water enters micro-cracks in the bearing rings that are caused by repeated stress cycles. This leads to corrosion and hydrogen embrittlement in the micro-cracks, reducing the time required for these cracks to propagate to an unacceptable-sized spall.

Water-based fluids, such as water glycol and invert emulsions, also have shown a reduction in bearing fatigue life. Although water from these sources is not the same as contamination, the results support the previous discussion concerning water-contaminated lubricants.

GREASE SELECTION

The successful use of bearing grease depends on the physical and chemical properties of the lubricant as well as application and environmental conditions. Because the choice of grease for a particular bearing under certain service conditions is often difficult to make, you should consult with your lubricant supplier or equipment maker for specific questions about lubrication requirements for your application. You also can contact your Timken engineer for general lubrication guidelines for any application.

Grease must be carefully selected with regard to its consistency at operating temperature. It should not exhibit thickening, separation of oil, acid formation or hardening to any marked degree. It should be smooth, non-fibrous and entirely free from chemically active ingredients. Its dropping point should be considerably higher than the operating temperature.



Timken® application-specific lubricants were developed by leveraging our knowledge of tribology and antifriction bearings, and how these two elements affect overall system performance. Timken lubricants help bearings and related components operate effectively in demanding industrial operations. High-temperature, anti-wear and water-resistant additives offer superior protection in challenging environments. Table D-17 provides an overview of the Timken greases available for general applications. Contact your Timken engineer for a more detailed publication on Timken lubrication solutions.

TABLE D-17. GREASE LUBRICATION SELECTION GUIDE

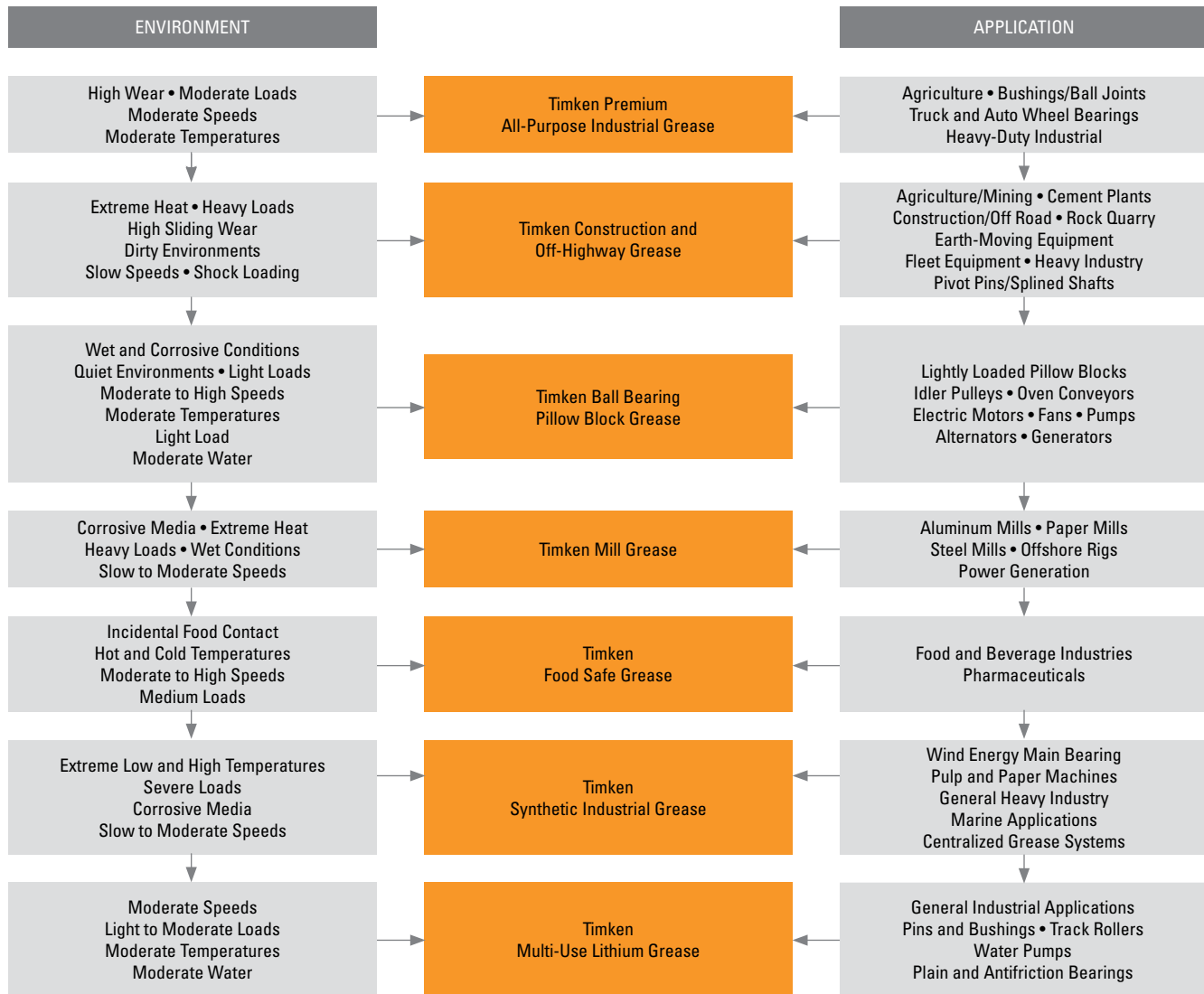

This selection guide is not intended to replace the specifications by the equipment builder, who is responsible for its performance.

Many bearing applications require lubricants with special properties or lubricants formulated specifically for certain environments, such as:

- Friction oxidation (fretting corrosion).
- Chemical and solvent resistance.
- Food handling.

For assistance with these or other areas requiring special lubricants, consult your Timken engineer.

GREASE USE GUIDELINES

It is important to use the proper amount of grease in the application. In typical industrial applications, the bearing cavity should be kept approximately one-third to one-half full. Less grease may result in the bearing being starved for lubrication. More grease may result in churning. Both conditions may result in excessive heat generation. As the grease temperature rises, viscosity decreases and the grease becomes thinner. This can reduce the lubricating effect and increase leakage of the grease from the bearing. It also may cause the grease components to separate, leading to a general breakdown of the lubricant properties. As the grease breaks down, bearing torque increases. In the case of excess grease resulting in churning, torque may also increase due to the resistance caused by the grease.

For best results, there should be ample space in the housing to allow room for excess grease to be thrown from the bearing. However, it is equally important that the grease be retained all around the bearing. If a large void exists between the bearings, grease closures should be used to prevent the grease from leaving the bearing area.

Only in low-speed applications may the housing be entirely filled with grease. This method of lubrication is a safeguard against the entry of foreign matter, where sealing provisions are inadequate for exclusion of contaminants or moisture.

During periods of non-operation, it is often wise to completely fill the housings with grease to protect the bearing surfaces. Prior to restarting operation, remove the excess grease and restore the proper level.

Applications utilizing grease lubrication should have a grease fitting and a vent at opposite ends of the housing near the top. A drain plug should be located near the bottom of the housing to allow the old grease to purge from the bearing.

Bearings should be relubricated at regular intervals to help prevent damage. Relubrication intervals are difficult to determine. If plant practice or experience with other applications is not available, consult your lubricant supplier.

Timken offers a range of lubricants to help bearings and related components operate effectively in demanding industrial operations. High-temperature, anti-wear and water-resistant additives offer greater protection in challenging environments. Timken also offers a line of single- and multi-point lubricators to simplify grease delivery.



Fig. D-10. Grease can easily be packed by hand.



Fig. D-11. Mechanical grease packer.

Grease application methods

Grease, in general, is easier to use than oil in industrial bearing applications. Most bearings that are initially packed with grease require periodic relubrication to operate efficiently.

Grease should be packed into the bearing so that it gets between the rolling elements.

Grease can be easily packed into small- and medium-size bearings by hand (fig. D-10). In shops where bearings are frequently regreased, a mechanical grease packer that forces grease through the bearing under pressure may be appropriate (fig. D-11). Regardless of the method, after packing the internal areas of the bearing, a small amount of grease also should be smeared on the outside of the rollers.

The two primary considerations that determine the relubrication cycle are operating temperature and sealing efficiency. High-operating-temperature applications generally require more frequent regreasing. The less efficient the seals, the greater the grease loss and the more frequently grease must be added.

Grease should be added any time the amount in the bearing falls below the desired amount. The grease should be replaced when its lubrication properties have been reduced through contamination, high temperature, water, oxidation or any other factors. For additional information on appropriate regreasing cycles, consult with the equipment manufacturer or your Timken engineer.

GREASE LUBRICATIONS FOR BEARING/HOUSING ASSEMBLIES

Polyurea and lithium-based greases are normally preferred for general-purpose bearing lubrication and are advantageous in high moisture applications. Both greases have good water-resistant characteristics. For temperature ranges of standard greases, see table D-16.

Frictional torque is influenced by the quantity and the quality of lubricant present. Excessive quantities of grease cause churning. The adverse effects of churn are accelerated with increases in operating speed. The churn results in excessive temperatures, separation of the grease components, and breakdown in lubrication values. In normal-speed applications, the housings should be kept approximately one-third to one-half full. Only in low-speed applications may the housing be entirely filled with grease. This method of lubrication is a safeguard against the entry of foreign matter, where sealing provisions are inadequate for exclusion of contaminants or moisture.

GENERAL-PURPOSE INDUSTRIAL GREASE

Polyurea and and lithium-based greases are typical of greases that can be used to lubricate many Timken bearing applications in all types of standard equipment.

Special consideration should be given to applications where speed, load, temperature or environmental conditions are extreme.

Lithium greases, lithium complex greases, or calcium sulfonate thickened grease are suitable for most centralized, single-point, or manually lubricated product. They should be a smooth, homogeneous and uniform, premium-quality product composed of mineral or synthetic oil, a thickener and appropriate inhibitors (see table D-18).

TABLE D-18. SUGGESTED LITHIUM SOAP, LITHIUM COMPLEX AND CALCIUM SULFONATE GREASE PROPERTIES

Thickener type	Lithium Complex, or equivalent
Consistency	NLGI No.1 or No. 2
Additives	Anti-wear, corrosion and oxidation inhibitors
Base oil	Mineral oil or synthetic
Viscosity at 40° C	ISO VG 150-220
Viscosity index	80 min.
Pour point	-18° C (0° F) max.

They should not contain materials that are corrosive or abrasive to roller bearings. The grease should have excellent mechanical and chemical stability. The grease should contain inhibitors to provide long-term protection against oxidation in high-performance applications and protect the bearings from corrosion in the presence of moisture. The suggested base oil viscosity covers a fairly wide range. Lower viscosity products should be used in high-speed and/or lightly loaded applications to minimize heat generation and torque. Higher viscosity products should be used in moderate- to low-speed applications and under heavy loads to maximize lubricant film thickness. Speed ratings are listed for each size/class part number in the Spherical Roller Bearing Catalog (order no. 10446) on pages 59-88. When application speeds exceed 70 percent of grease speed rating, consider increasing RIC by one ISO clearance range (CNormal to C3). Table D-19 is provided as a reference for typical grease thickener compatibilities. Consult your lubricant supplier for further information for your specific requirement. For general industrial applications, consider a grease that is NLGI No. 1 or No. 2, with a ISO 150 to 220 viscosity grade.

NOTE

Mixing greases can result in improper bearing lubrication. Always follow the specific lubrication instructions of your equipment supplier.

TABLE D-19. GREASE COMPATIBILITY CHART

	Al Complex	Ba Complex	Ca Stearate	Ca 12 Hydroxy	Ca Complex	Ca Sulfonate	Non-Soap Clay	Li Stearate	Li 12 Hydroxy	Li Complex	Polyurea	Polyurea S S
Aluminum Complex	Best Choice	Incompatible	Incompatible	Compatible	Incompatible	Borderline	Incompatible	Incompatible	Incompatible	Compatible	Incompatible	Compatible
Timken Food Safe	Best Choice	Incompatible	Incompatible	Compatible	Incompatible	Borderline	Incompatible	Incompatible	Incompatible	Compatible	Incompatible	Compatible
Barium Complex	Incompatible	Best Choice	Incompatible	Compatible	Incompatible	Compatible	Incompatible	Incompatible	Incompatible	Incompatible	Incompatible	Borderline
Calcium Stearate	Incompatible	Incompatible	Best Choice	Compatible	Incompatible	Compatible	Compatible	Compatible	Borderline	Compatible	Incompatible	Compatible
Calcium 12 Hydroxy	Compatible	Compatible	Compatible	Best Choice	Borderline	Borderline	Compatible	Compatible	Compatible	Compatible	Incompatible	Compatible
Calcium Complex	Incompatible	Incompatible	Incompatible	Borderline	Best Choice	Incompatible	Incompatible	Incompatible	Incompatible	Compatible	Compatible	Compatible
Calcium Sulfonate	Borderline	Compatible	Compatible	Borderline	Incompatible	Best Choice	Incompatible	Borderline	Borderline	Compatible	Incompatible	Compatible
Timken Premium Mill Timken Heavy-Duty Moly	Borderline	Compatible	Compatible	Borderline	Incompatible	Best Choice	Incompatible	Borderline	Borderline	Compatible	Incompatible	Compatible
Clay Non-Soap	Incompatible	Incompatible	Compatible	Compatible	Incompatible	Incompatible	Best Choice	Incompatible	Incompatible	Incompatible	Incompatible	Borderline
Lithium Stearate	Incompatible	Incompatible	Compatible	Compatible	Incompatible	Borderline	Incompatible	Best Choice	Compatible	Compatible	Incompatible	Compatible
Lithium 12 Hydroxy	Incompatible	Incompatible	Borderline	Compatible	Incompatible	Borderline	Incompatible	Compatible	Best Choice	Compatible	Incompatible	Compatible
Lithium Complex	Compatible	Incompatible	Compatible	Compatible	Compatible	Compatible	Incompatible	Compatible	Compatible	Best Choice	Incompatible	Compatible
Polyurea Conventional	Incompatible	Incompatible	Incompatible	Incompatible	Compatible	Incompatible	Incompatible	Incompatible	Incompatible	Incompatible	Best Choice	Compatible
Polyurea Shear Stable	Compatible	Borderline	Compatible	Compatible	Compatible	Compatible	Borderline	Compatible	Compatible	Compatible	Compatible	Best Choice
Timken Multi-Use	Incompatible	Incompatible	Borderline	Compatible	Incompatible	Borderline	Incompatible	Compatible	Best Choice	Compatible	Incompatible	Compatible
Timken All -Purpose Timken Synthetic	Compatible	Incompatible	Compatible	Compatible	Compatible	Compatible	Incompatible	Compatible	Compatible	Best Choice	Incompatible	Compatible
Timken Pillow Block	Compatible	Borderline	Compatible	Compatible	Compatible	Compatible	Borderline	Compatible	Compatible	Compatible	Compatible	Best Choice



APPLICATION CONSIDERATIONS

For higher-speed applications (operating at 75 percent of the grease speed rating or more), a grease with a lighter base oil viscosity (ISO 100-150) can be considered. Conversely, for lower-speed applications, a grease with a heavier base oil viscosity (ISO 320-460) can be considered. For lower-speed applications operating at colder start-up temperatures ($>-18^{\circ}\text{C}$ [0°F]), consider a softer grease (NLGI grade 1) with an approved EP additive. The lighter grade will allow more grease flow into the bearing contact area and the EP additive will reduce wear during start-up. An ISO 460 base oil viscosity also can be considered.

When lower-speed applications operate at higher temperatures ($>149^{\circ}\text{C}$ [300°F]), consult a local Timken engineer.

GREASE FILL

For normal industrial applications, fill the bearing void to 100 percent full and the housing void to 40–60 percent full. For high-speed applications, fill the bearing void to 100 percent full and the housing void to 30–40 percent full. The free volume of the bearing can be estimated by first calculating the solid ring volume of the bearing. Then, weigh the bearing and divide the weight by the density of steel. This actual volume can then be subtracted from the solid ring volume. The resultant value is an estimate of the free volume of the bearing available for grease fill. When the grease volume is determined for the application, multiplying this value by the density of the grease will yield the approximate weight of the grease fill. After weighing the grease required, apply approximately 75 percent of the amount into the cage and roller assembly. The remaining amount of grease should then be applied to both inner and outer rings in equal amounts. The preservatives applied to bearing components are compatible with nearly all industrial greases and should not be wiped or cleaned prior to packing the bearing. If in doubt, contact a local Timken engineer.



SPHERICAL ROLLER BEARINGS

Timken® spherical roller bearings feature all of the characteristics that have made Timken renowned – superior design, reliable performance and comprehensive technical support. Spherical roller bearings are designed to manage high radial loads and perform consistently, even when misalignment, marginal lubrication, contamination, extreme speeds and critical application stresses are present.

Nomenclature.....	D-36
Spherical Roller Bearing Product Data Tables	D-37





SPHERICAL ROLLER BEARINGS NOMENCLATURE

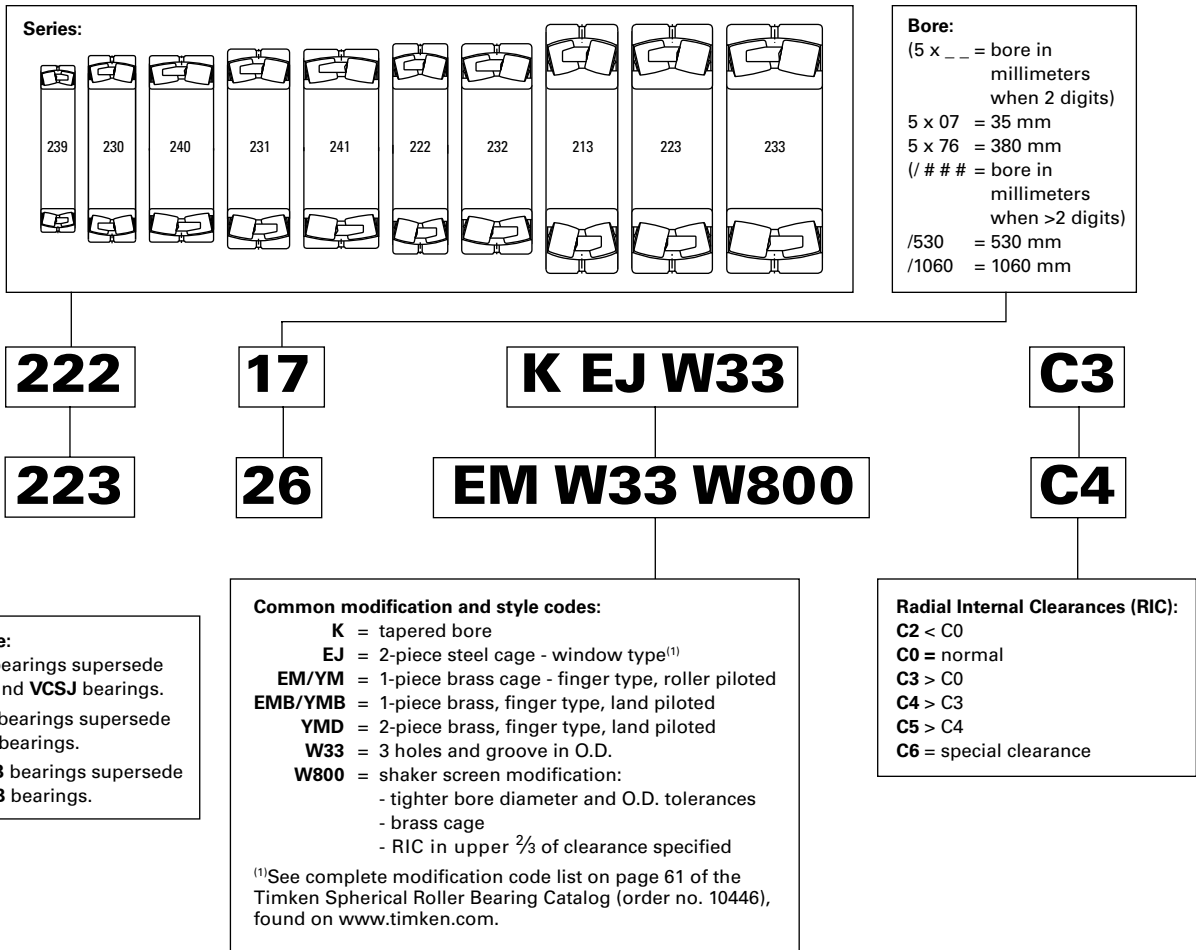

Fig. D-12. Timken® spherical roller bearing nomenclature.

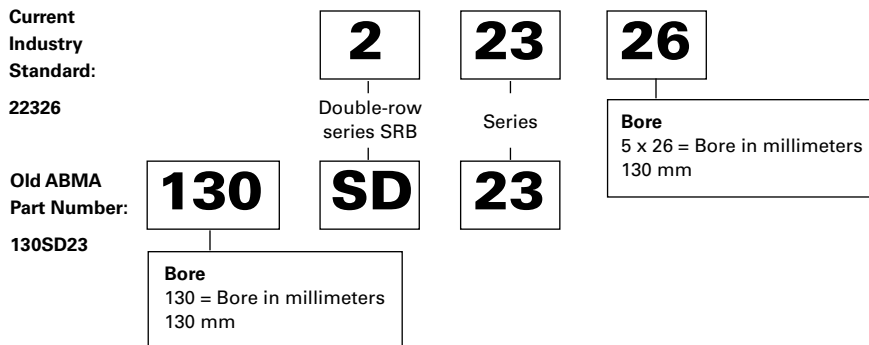
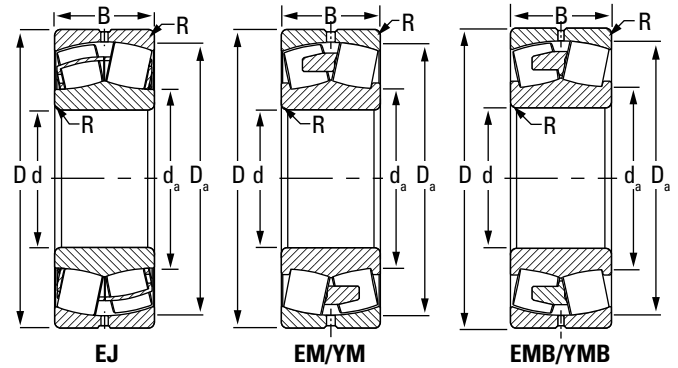

Fig. D-13. Equivalence between current ISO and old ABMA part numbering.

222 SERIES (225, 222 SERIES SAF, SDAF)

- Bearings are available with a tapered bore for adapter-type mounting. To order, add the suffix K to bearing number (e.g., 23120K).
- Consult your Timken engineer and www.timken.com for up-to-date information about the availability of the bearings you have selected.



Bearing Part No.	Bearing Dimensions			Load Ratings		Cage Type	Mounting Data			Equivalent Radial Load Factors ⁽²⁾				Geometry Factor ⁽³⁾	Thermal Speed Ratings ⁽⁴⁾		Wt.
							Fillet ⁽¹⁾ (Max.)	Backing Dia.		Dynamic		Static	Oil		Grease		
	R	Shaft d _a	Housing D _a	F _a ≤ e F _r	F _a > e F _r			In All Cases	RPM	RPM							
	mm in.	mm in.	mm in.	kN lbf.	kN lbf.		mm in.	mm in.	mm in.	e	Y	Y	Y ₀		C _g	RPM	
22209	45 1.7717	85 3.3465	23 0.9055	104 23500	101 22800	EJ / EM	1 0.04	55 2.2	77 3	0.26	2.64	3.93	2.58	0.046	6800	5500	0.6 1.3
22210	50 1.9685	90 3.5433	23 0.9055	112 25200	112 25100	EJ / EM	1 0.04	59 2.3	82 3.2	0.24	2.84	4.23	2.78	0.049	6200	5000	0.6 1.3
22211	55 2.1654	100 3.937	25 0.9843	134 30100	134 30100	EJ / EM	1.5 0.06	66 2.6	91 3.6	0.23	2.95	4.4	2.89	0.052	5800	4700	0.9 2.0
22212	60 2.3622	110 4.3307	28 1.1024	163 36600	164 36900	EJ / EM	1.5 0.06	72 2.8	100 4	0.24	2.84	4.23	2.78	0.055	5500	4400	1.2 2.6
22213	65 2.5591	120 4.7244	31 1.2205	198 44600	204 45900	EJ / EM	1.5 0.06	78 3.1	109 4.3	0.24	2.79	4.15	2.73	0.058	5100	4200	1.6 3.5
22214	70 2.7559	125 4.9213	31 1.2205	205 46000	219 49200	EJ / EM	1.5 0.06	84 3.3	114 4.5	0.23	2.9	4.32	2.84	0.063	4800	3900	1.6 3.5
22215	75 2.9528	130 5.1181	31 1.2205	222 49900	240 54100	EJ	1.5 0.06	88 3.5	120 4.7	0.22	3.14	4.67	3.07	0.062	4600	3700	1.7 3.7
22216	80 3.1496	140 5.5118	33 1.2992	254 57200	278 62500	EJ / EM	2 0.08	95 3.7	129 5.1	0.22	3.14	4.67	3.07	0.065	4300	3500	2.2 4.8
22216	80 3.1496	140 5.5118	33 1.2992	245 55100	263 59200	EJ / EM	2 0.08	95 3.7	129 5.1	0.22	3.14	4.67	3.07	0.065	4400	3600	2.2 4.8
22217	85 3.3465	150 5.9055	36 1.4173	286 64200	302 67900	EJ / EM	2 0.08	101 4	139 5.5	0.22	3.07	4.57	3	0.068	4200	3400	2.7 5.9
22218	90 3.5433	160 6.2992	40 1.5748	355 79700	388 87200	EJ / EM	2 0.08	105 4.2	146 5.8	0.23	2.9	4.31	2.83	0.07	4000	3300	3.5 7.7
22219	95 3.7402	170 6.6929	43 1.6929	385 86600	441 99000	EJ / EM	2 0.08	114 4.5	155 6.1	0.23	2.88	4.29	2.82	0.076	3900	3200	4.2 9.2
22220	100 3.937	180 7.0866	46 1.811	435 97700	502 113000	EJ / EM	2 0.08	120 4.7	163 6.4	0.24	2.85	4.24	2.78	0.079	3800	3100	5.0 11.0
22222	110 4.3307	200 7.874	53 2.0866	555 125000	653 147000	EJ / EM	2 0.08	133 5.2	182 7.2	0.25	2.73	4.06	2.67	0.084	3500	2900	7.2 15.8

⁽¹⁾Maximum shaft or housing fillet radius that bearing corners will clear.

⁽²⁾These factors apply for both inch and metric calculations. See Timken Engineering Manual (order no. 10424) for instructions on use.

⁽³⁾Geometry constant for Lubrication Life Factor a₃₁ is found in the Bearing Ratings section of the Engineering Manual (order no. 10424).

⁽⁴⁾See thermal speed ratings in the Engineering Manual (order no. 10424).

NOTE: Where EJ and EM/EMB have different load ratings, the more conservative one was taken to use for both assemblies.

NOTE: Tolerance and shaft diameters are shown in the tables D-2 and D-3 on pages D-5 and D-6 as variances from nominal bearing bore.

Continued on next page.



TIMKEN® SAF SPLIT-BLOCK HOUSED UNITS

SPHERICAL ROLLER BEARINGS • 225 SERIES (225, 222 SERIES SAF, SDAF)

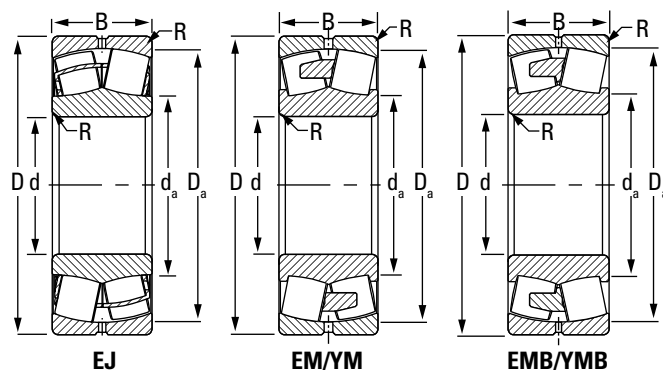

Continued from previous page.

Bearing Part No.	Bearing Dimensions			Load Ratings		Cage Type	Mounting Data			Equivalent Radial Load Factors ⁽²⁾				Geometry Factor ⁽³⁾ C _g	Thermal Speed Ratings ⁽⁴⁾		Wt.
							Fillet ⁽¹⁾ (Max.) R	Backing Dia.		Dynamic		Static In All Cases Y ₀	Oil		Grease		
	Shaft d _a	Housing D _a	$\frac{F_a}{F_r} \leq e$ X = 1 Y	$\frac{F_a}{F_r} > e$ X = 0.67 Y	Oil RPM			Grease RPM									
	mm in.	mm in.	mm in.	kN lbf.	kN lbf.		mm in.	mm in.	mm in.	e	Y	Y	Y ₀		C _g	RPM	
22224	120 4.7244	215 8.4646	58 2.2835	647 145000	772 174000	EJ / EM	2 0.08	143 5.6	196 7.7	0.25	2.7	4.02	2.64	0.081	3200	2600	9.0 19.8
22226	130 5.1181	230 9.0551	64 2.5197	757 170000	945 212000	EJ / EM	2.5 0.1	155 6.1	210 8.3	0.26	2.62	3.9	2.56	0.079	2900	2400	11.3 24.9
22228	140 5.5118	250 9.8425	68 2.6772	863 194000	1060 237000	EJ / EM	2.5 0.1	167 6.6	228 9	0.25	2.67	3.98	2.61	0.082	2600	2200	14.2 31.2
22230	150 5.9055	270 10.6299	73 2.874	1000 225000	1230 276000	EJ / EM	2.5 0.1	179 7	246 9.7	0.25	2.69	4	2.63	0.087	2400	2000	17.8 39.2
22232	160 6.2992	290 11.4173	80 3.1496	1170 263000	1450 326000	EJ / EM	2.5 0.1	192 7.5	264 10.4	0.26	2.62	3.91	2.57	0.09	2200	1800	23.0 50.6
22234	170 6.6929	310 12.2047	86 3.3858	1340 301000	1680 379000	EJ / EM	3 0.12	204 8	281 11.1	0.26	2.61	3.89	2.55	0.094	2000	1700	28.5 62.7
22236	180 7.0866	320 12.5984	86 3.3858	1340 301000	1700 382000	EJ / EM	3 0.12	215 8.5	292 11.5	0.25	2.72	4.05	2.66	0.097	1900	1600	29.1 64.0
22238	190 7.4803	340 13.3858	92 3.622	1550 348000	1960 440000	EJ / EMB	3 0.12	226 8.9	310 12.2	0.25	2.67	3.98	2.62	0.1	1800	1500	36.1 79.4
22240	200 7.874	360 14.1732	98 3.8583	1580 356000	2010 452000	EJ / EMB	3 0.12	236 9.3	323 12.7	0.27	2.5	3.72	2.44	0.103	1700	1500	43.6 95.9
22244	220 8.6614	400 15.748	108 4.252	1850 415000	2310 520000	EJ / EMB	3 0.12	261 10.3	359 14.1	0.27	2.51	3.73	2.45	0.11	1500	1300	59.4 130.7

⁽¹⁾Maximum shaft or housing fillet radius that bearing corners will clear.

⁽²⁾These factors apply for both inch and metric calculations. See engineering section for instructions on use.

⁽³⁾Geometry constant for Lubrication Life Factor a₃ is found in the Bearing Ratings section of the Engineering Manual (order no. 10424).

⁽⁴⁾See thermal speed ratings in the Engineering Manual (order no. 10424).

NOTE: Where EJ and EM/EMB have different load ratings, the more conservative one was taken to use for both assemblies.

NOTE: Tolerance and shaft diameters are shown in the tables D-2 and D-3 on pages D-5 and D-6 as variances from nominal bearing bore.

223 SERIES (226, 223 SERIES SAF, SDAF)

- Bearings are available with a tapered bore for adapter-type mounting. To order, add the suffix K to bearing number (e.g., 23120K).
- Consult your Timken engineer and www.timken.com for up-to-date information about the availability of the bearings you have selected.

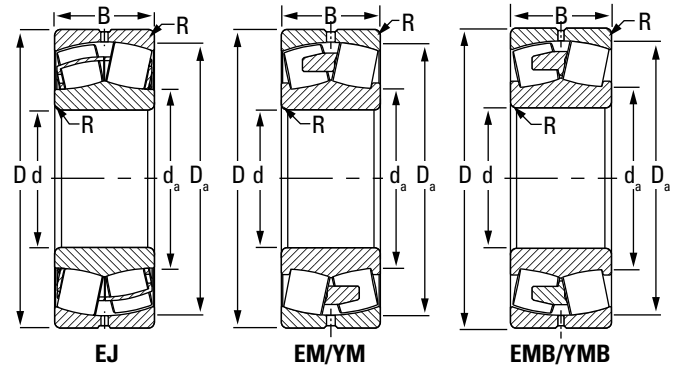

Bearing Part No.	Bearing Dimensions			Load Ratings		Cage Type	Mounting Data			Equivalent Radial Load Factors ⁽²⁾				Geometry Factor ⁽³⁾	Thermal Speed Ratings ⁽⁴⁾		Wt.
										Dynamic		Static			Oil	Grease	
	Bore d	O.D. D	Width B	Dynamic C	Static Co		Dynamic $\frac{F_a \leq e}{F_r}$	Dynamic $\frac{F_a > e}{F_r}$	Static In All Cases	RPM	RPM	kg lbs.					
22315	75 2.9528	160 6.2992	55 2.1654	450 101000	478 107000	EJ / EM	2 0.08	97 3.8	144 5.7	0.33	2.04	3.04	2	0.071	3900	3300	5.4 11.9
22316	80 3.1496	170 6.6929	58 2.2835	499 112000	534 120000	EJ / EM	2 0.08	103 4.1	153 6	0.33	2.06	3.06	2.01	0.073	3700	3200	6.4 14.1
22317	85 3.3465	180 7.0866	60 2.3622	569 128000	623 140000	EJ / EM	2.5 0.1	110 4.3	162 6.4	0.32	2.11	3.14	2.06	0.076	3500	3000	7.5 16.5
22318	90 3.5433	190 7.4803	64 2.5197	634 143000	703 158000	EJ / EM	2.5 0.1	116 4.6	171 6.7	0.32	2.09	3.11	2.04	0.079	3300	2800	8.8 19.4
22319	95 3.7402	200 7.874	67 2.6378	694 156000	774 174000	EJ / EM	2.5 0.1	122 4.8	180 7.1	0.32	2.1	3.13	2.05	0.082	3000	2600	10.2 22.4
22320	100 3.937	215 8.4646	73 2.874	779 175000	856 193000	EJ / EM	2.5 0.1	130 5.1	193 7.6	0.33	2.06	3.07	2.02	0.072	2800	2400	12.8 28.2
22322	110 4.3307	240 9.4488	80 3.1496	949 213000	1050 236000	EJ / EM	2.5 0.1	144 5.7	215 8.5	0.32	2.08	3.1	2.04	0.076	2500	2100	17.8 39.2
22324	120 4.7244	260 10.2362	86 3.3858	1080 244000	1210 272000	EJ / EM	2.5 0.1	157 6.2	234 9.2	0.32	2.11	3.15	2.07	0.081	2100	1900	22.0 48.4
22326	130 5.1181	280 11.0236	93 3.6614	1250 281000	1410 318000	EJ / EM	3 0.12	169 6.7	252 9.9	0.32	2.11	3.14	2.06	0.085	1900	1700	27.4 60.3
22328	140 5.5118	300 11.811	102 4.0157	1450 326000	1670 375000	EJ / EM	3 0.12	182 7.1	270 10.6	0.33	2.06	3.06	2.01	0.089	1700	1500	34.5 75.9
22330	150 5.9055	320 12.5984	108 4.252	1700 382000	2010 452000	EJ / EMB	3 0.12	194 7.6	288 11.3	0.33	2.08	3.09	2.03	0.093	1600	1400	43.0 94.6
22332	160 6.2992	340 13.3858	114 4.4882	1890 424000	2250 507000	EJ / EMB	3 0.12	207 8.1	306 12	0.32	2.09	3.11	2.04	0.096	1500	1300	51.0 112.2
22334	170 6.6929	360 14.1732	120 4.7244	2100 471000	2510 565000	EJ / EMB	3 0.12	219 8.6	325 12.8	0.32	2.11	3.15	2.07	0.1	1300	1200	59.9 131.8
22336	180 7.0866	380 14.9606	126 4.9606	2290 514000	2770 623000	EJ / EMB	3 0.12	232 9.2	343 13.5	0.32	2.13	3.17	2.08	0.083	1200	1100	70.0 154.0
22338	190 7.4803	400 15.748	132 5.1969	2490 559000	3010 678000	EJ / EMB	4 0.16	245 9.6	361 14.2	0.32	2.12	3.15	2.07	0.086	1200	1000	80.9 178.0
22340	200 7.874	420 16.5354	138 5.4331	2260 507000	2910 655000	YMB	4 0.157	247 9.74	369 14.52	0.33	2.02	3.01	1.98	0.076	1100	970	93.0 204.6

⁽¹⁾Maximum shaft or housing fillet radius that bearing corners will clear.

⁽²⁾These factors apply for both inch and metric calculations. See engineering section for instructions on use.

⁽³⁾Geometry constant for Lubrication Life Factor a_{31} is found in the Bearing Ratings section of the Engineering Manual (order no. 10424).

⁽⁴⁾See thermal speed ratings in the Engineering Manual (order no. 10424).

NOTE: Where EJ and EM/EMB have different load ratings, the more conservative one was taken to use for both assemblies.

NOTE: Tolerance and shaft diameters are shown in the tables D-2 and D-3 on pages D-5 and D-6 as variances from nominal bearing bore.

**230 SERIES
(230K SERIES SAF, SDAF)**

- Bearings are available with a tapered bore for adapter-type mounting. To order, add the suffix K to bearing number (e.g., 23120K).
- Consult your Timken engineer and www.timken.com for up-to-date information about the availability of the bearings you have selected.

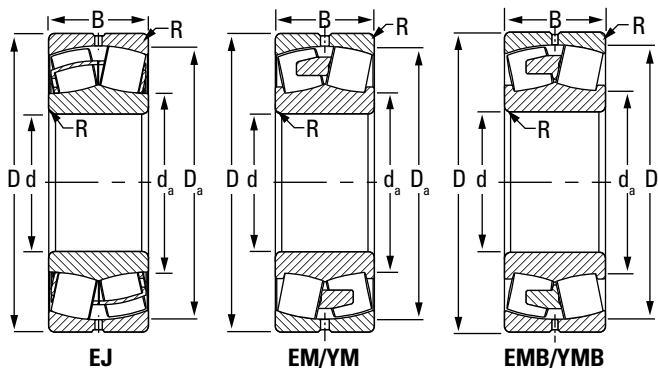

Bearing Part No.	Bearing Dimensions			Load Ratings		Cage Type	Mounting Data			Equivalent Radial Load Factors ⁽²⁾				Geometry Factor ⁽³⁾	Thermal Speed Ratings ⁽⁴⁾		Wt.
							Fillet ⁽¹⁾ (Max.)	Backing Dia.		e	Dynamic		Static		Oil	Grease	
	R	Shaft d _a	Housing D _a	F _a / F _r ≤ e	F _a / F _r > e			In All Cases	RPM		RPM						
	Bore d	O.D. D	Width B	Dynamic C	Static C ₀		mm in.	mm in.	mm in.	Y	Y	Y ₀	kg lbs.				
23024	120 4.7244	180 7.0866	46 1.811	408 91700	574 129000	EJ	2 0.08	134 5.3	167 6.6	0.22	3.02	4.49	2.95	0.084	3300	2700	4.0 8.8
24024	120 4.7244	180 7.0866	60 2.3622	523 117000	762 171000	EJ	2 0.08	132 5.2	167 6.6	0.29	2.32	3.45	2.26	0.083	2700	2200	5.2 11.4
23026	130 5.1181	200 7.874	52 2.0472	518 116000	723 162000	EJ	2 0.08	146 5.8	185 7.3	0.23	2.94	4.37	2.87	0.089	3100	2500	5.9 13.0
23028	140 5.5118	210 8.2677	53 2.0866	551 124000	802 180000	EJ	2 0.08	158 6.2	196 7.7	0.22	3.1	4.61	3.03	0.085	2800	2300	6.2 13.6
23030	150 5.9055	225 8.8583	56 2.2047	621 140000	911 205000	EJ / EM	2 0.08	169 6.7	210 8.3	0.21	3.14	4.68	3.07	0.089	2600	2100	7.7 16.9
23032	160 6.2992	240 9.4488	60 2.3622	705 159000	1040 235000	EJ / EM	2 0.08	180 7.1	224 8.8	0.22	3.12	4.65	3.05	0.093	2400	2000	9.4 20.7
23034	170 6.6929	260 10.2362	67 2.6378	858 193000	1250 282000	EJ / EM	2 0.08	192 7.6	242 9.5	0.22	3.02	4.49	2.95	0.097	2200	1800	12.8 28.2
23036	180 7.0866	280 11.0236	74 2.9134	1020 229000	1480 332000	EJ / EM	2 0.08	204 8	260 10.2	0.23	2.91	4.34	2.85	0.093	2000	1700	16.8 37.0
23038	190 7.4803	290 11.4173	75 2.9528	1060 239000	1580 355000	EJ / EM	2 0.08	214 8.4	270 10.6	0.23	3	4.47	2.93	0.096	1900	1600	17.8 39.2
23040	200 7.874	310 12.2047	82 3.2283	1230 276000	1760 395000	EJ / EM	2 0.08	225 8.9	289 11.4	0.23	2.95	4.4	2.89	0.095	1800	1500	22.6 49.7
23044	220 8.6614	340 13.3858	90 3.5433	1340 300000	1970 443000	EJ / EM	2.5 0.1	247 9.7	313 12.3	0.24	2.77	4.13	2.71	0.105	1700	1400	29.8 65.6
23048	240 9.4488	360 14.1732	92 3.622	1400 315000	2140 480000	EJ / EM	2.5 0.1	267 10.5	334 13.1	0.23	2.91	4.34	2.85	0.111	1500	1300	31.9 70.2
23052	260 10.2362	400 15.748	104 4.0945	1820 409000	2740 617000	EJ / EMB	3 0.12	291 11.5	369 14.5	0.24	2.85	4.24	2.78	0.078	1300	1100	47.6 104.7
23056	280 11.024	420 16.535	106 4.173	1660 373000	2790 627000	YMB	3 0.12	312 12.3	389 15.3	0.23	2.92	4.35	2.86	0.088	1100	930	51.0 112.2

⁽¹⁾Maximum shaft or housing fillet radius that bearing corners will clear.

⁽²⁾These factors apply for both inch and metric calculations. See engineering section for instructions on use.

⁽³⁾Geometry constant for Lubrication Life Factor a₃₁ is found in the Bearing Ratings section of the Engineering Manual (order no. 10424).

⁽⁴⁾See thermal speed ratings in the Engineering Manual (order no. 10424).

NOTE: Where EJ and EM/EMB have different load ratings, the more conservative one was taken to use for both assemblies.

NOTE: Tolerance and shaft diameters are shown in the tables D-2 and D-3 on pages D-5 and D-6 as variances from nominal bearing bore.

Continued on next page.

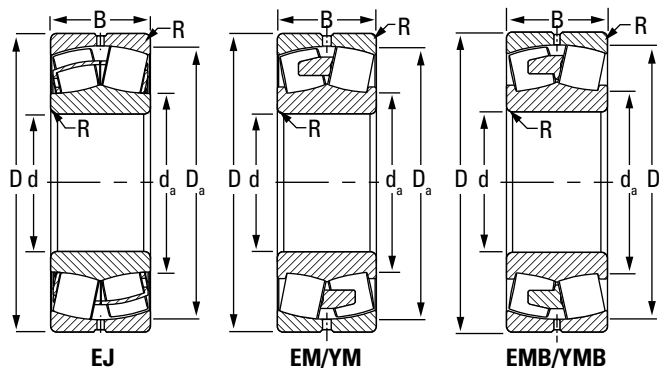

Continued from previous page.

Bearing Part No.	Bearing Dimensions			Load Ratings		Cage Type	Mounting Data			Equivalent Radial Load Factors ⁽²⁾				Geometry Factor ⁽³⁾	Thermal Speed Ratings ⁽⁴⁾		Wt.
							Fillet ⁽¹⁾ (Max.)	Backing Dia.		e	Dynamic		Static		Oil	Grease	
	R	Shaft d _a	Housing D _a	F _a /F _r ≤ e	F _a /F _r > e			In All Cases	RPM		RPM						
	Bore d	O.D. D	Width B	Dynamic C	Static C ₀		mm in.	mm in.	mm in.	Y	Y	Y ₀	kg lbs.				
23060	300 11.811	460 18.11	118 4.646	2120 477000	3540 796000	YMB	3 0.12	336 13.2	425 16.8	0.24	2.87	4.27	2.8	0.093	980	830	71.0 156.2
23064	320 12.598	480 18.898	121 4.764	2200 494000	3850 867000	YMB	3 0.12	357 14.1	444 17.5	0.23	2.93	4.36	2.86	0.096	910	780	77.4 170.3
23068	340 13.386	520 20.472	133 5.236	2640 593000	4620 1040000	YMB	4 0.16	384 15.1	481 18.9	0.23	2.96	4.4	2.89	0.101	830	710	102.7 225.9
23072	360 14.173	540 21.26	134 5.276	2590 583000	4600 1030000	YMB	4 0.16	403 15.9	499 19.7	0.23	2.94	4.38	2.88	0.102	800	680	108.3 238.3
23076	380 14.961	560 22.047	135 5.315	2800 630000	5090 1140000	YMB	4 0.16	422 16.6	520 20.5	0.22	3.08	4.58	3.01	0.105	740	630	114.2 251.2
23080	400 15.748	600 23.622	148 5.827	3310 744000	5950 1340000	YMB	4 0.16	447 17.6	555 21.9	0.23	2.98	4.44	2.92	0.111	690	590	148.7 327.1
23084	420 16.535	620 24.409	150 5.906	3450 774000	6360 1430000	YMB	4 0.16	467 18.4	576 22.7	0.22	3.05	4.54	2.98	0.114	650	560	156.0 343.2
23088	440 17.323	650 25.591	157 6.181	3750 844000	6970 1570000	YMB	5 0.2	489 19.3	603 23.7	0.22	3.04	4.53	2.97	0.117	610	520	180.0 396.0
23092	460 18.11	680 26.772	163 6.417	4060 913000	7570 1700000	YMB	5 0.2	512 20.1	631 24.9	0.22	3.06	4.56	2.99	0.118	580	500	205.0 451.0
23096	480 18.898	700 27.559	165 6.496	4170 938000	7980 1790000	YMB	5 0.2	532 21	651 25.6	0.22	3.14	4.67	3.07	0.124	550	470	215.0 473.0
230/500	500 19.685	720 28.347	167 6.575	4290 965000	8160 1840000	YMB	5 0.2	550 21.7	673 26.5	0.21	3.26	4.85	3.18	0.126	530	460	222.0 488.4
230/530	530 20.866	780 30.709	185 7.284	5150 1160000	9720 2190000	YMB	5 0.2	588 23.2	725 28.6	0.21	3.14	4.68	3.07	0.132	480	420	302.6 665.7

⁽¹⁾Maximum shaft or housing fillet radius that bearing corners will clear.

⁽²⁾These factors apply for both inch and metric calculations. See engineering section for instructions on use.

⁽³⁾Geometry constant for Lubrication Life Factor a₃ is found in the Bearing Ratings section of the Engineering Manual (order no. 10424).

⁽⁴⁾See thermal speed ratings in the Engineering Manual (order no. 10424).

NOTE: Where EJ and EM/EMB have different load ratings, the more conservative one was taken to use for both assemblies.

NOTE: Tolerance and shaft diameters are shown in the tables D-2 and D-3 on pages D-5 and D-6 as variances from nominal bearing bore.

**231 SERIES
(231, 231K SERIES SDAF)**

- Bearings are available with a tapered bore for adapter-type mounting. To order, add the suffix K to bearing number (e.g., 23120K).
- Consult your Timken engineer and www.timken.com for up-to-date information about the availability of the bearings you have selected.

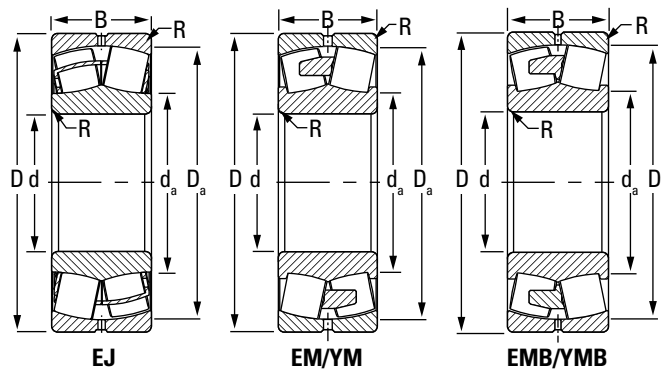

Bearing Part No.	Bearing Dimensions			Load Ratings		Cage Type	Mounting Data			Equivalent Radial Load Factors ⁽²⁾				Geometry Factor ⁽³⁾	Thermal Speed Ratings ⁽⁴⁾		Wt.
							Fillet ⁽¹⁾ (Max.)	Backing Dia.		e	Dynamic		Static In All Cases		Oil	Grease	
	R	Shaft d _a	Housing D _a	$\frac{F_a}{F_r} \leq e$ X = 1	$\frac{F_a}{F_r} > e$ X = 0.67			Y ₀	RPM		RPM						
	Bore d	O.D. D	Width B	Dynamic C	Static C ₀		mm in.	mm in.	mm in.		Y	Y	Y ₀		C _g		
23152	260 10.236	440 17.323	144 5.669	2440 549000	3910 879000	YMB	3 0.12	302 11.9	400 15.7	0.30	2.23	3.31	2.18	0.086	870	760	90.0 198.0
23156	280 11.024	460 18.11	146 5.748	2530 570000	4140 930000	YMB	4 0.16	320 12.6	419 16.5	0.30	2.26	3.36	2.21	0.09	800	710	94.5 207.9
23160	300 11.811	500 19.685	160 6.299	3070 691000	5110 1150000	YMB	4 0.16	345 13.6	453 17.8	0.30	2.25	3.35	2.20	0.093	710	630	128.7 283.1
23164	320 12.598	540 21.26	176 6.929	3650 819000	5930 1330000	YMB	4 0.16	367 14.4	490 19.3	0.31	2.14	3.19	2.10	0.099	650	580	167.2 367.8
23168	340 13.386	580 22.835	190 7.48	4110 924000	6830 1540000	YMB	4 0.16	397 15.6	526 20.7	0.30	2.22	3.30	2.17	0.103	590	530	210.3 462.7
23172	360 14.173	600 23.622	192 7.559	4250 956000	7280 1640000	YMB	4 0.16	419 16.5	546 21.5	0.29	2.29	3.42	2.24	0.106	560	500	222.1 488.6
23176	380 14.961	620 24.409	194 7.638	4490 1010000	7580 1700000	YMB	4 0.16	431 17	566 22.3	0.30	2.28	3.39	2.23	0.109	530	470	232.6 511.7
23180	400 15.748	650 25.591	200 7.874	4770 1070000	8110 1820000	YMB	5 0.2	454 17.9	594 23.4	0.29	2.32	3.46	2.27	0.11	500	450	261.6 575.5
23184	420 16.535	700 27.559	224 8.819	5720 1290000	9640 2170000	YMB	5 0.2	480 18.9	636 25.1	0.31	2.21	3.20	2.16	0.117	450	410	350.8 771.8
23188	440 17.323	720 28.347	226 8.898	5970 1340000	10300 2310000	YMB	5 0.2	500 19.7	657 25.9	0.30	2.26	3.37	2.21	0.117	430	390	367.8 809.2
23192	460 18.11	760 29.921	240 9.449	6500 1460000	11100 2500000	YMB	6 0.24	524 20.6	692 27.2	0.30	2.24	3.33	2.19	0.123	410	370	436.9 961.2
23196	480 18.898	790 31.102	248 9.764	7110 1600000	12400 2790000	YMB	6 0.24	547 21.5	719 28.3	0.30	2.26	3.36	2.21	0.124	380	340	490.4 1078.9

⁽¹⁾Maximum shaft or housing fillet radius that bearing corners will clear.

⁽²⁾These factors apply for both inch and metric calculations. See engineering section for instructions on use.

⁽³⁾Geometry constant for Lubrication Life Factor a_3 is found in the Bearing Ratings section of the Engineering Manual (order no. 10424).

⁽⁴⁾See thermal speed ratings in the Engineering Manual (order no. 10424).

NOTE: Tolerance and shaft diameters are shown in the tables D-2 and D-3 on pages D-5 and D-6 as variances from nominal bearing bore.

232 SERIES (232, 232K SERIES SDAF)

- Bearings are available with a tapered bore for adapter-type mounting. To order, add the suffix K to bearing number (e.g., 23120K).
- Consult your Timken engineer and www.timken.com for up-to-date information about the availability of the bearings you have selected.

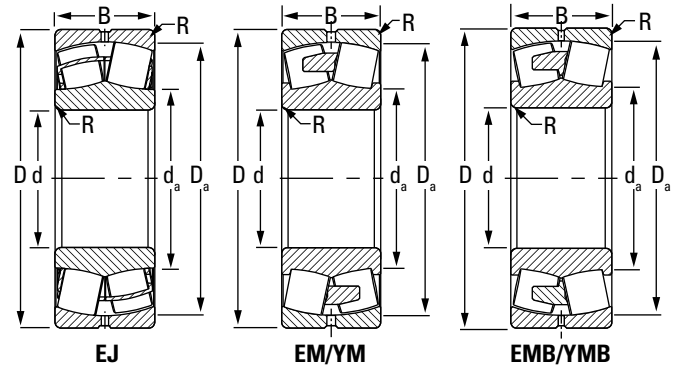

Bearing Part No.	Bearing Dimensions			Load Ratings		Cage Type	Mounting Data			Equivalent Radial Load Factors ⁽²⁾				Geometry Factor ⁽³⁾	Thermal Speed Ratings ⁽⁴⁾		Wt.
							Fillet ⁽¹⁾ (Max.)	Backing Dia.		e	$\frac{F_a}{F_r} \leq e$ X = 1	$\frac{F_a}{F_r} > e$ X = 0.67	Static In All Cases Y ₀		Oil	Grease	
	R	Shaft d _a	Housing D _a	Y	Y			Y ₀									
	mm in.	mm in.	mm in.	kN lbf.	kN lbf.		mm in.	mm in.	mm in.						RPM	RPM	
23248	240 9.449	440 17.323	160 6.299	2780 625000	4150 932000	YMB	3 0.12	281 11.1	394 15.5	0.35	1.92	2.86	1.88	0.082	760	680	108.1 237.8
23252	260 10.236	480 18.898	174 6.85	3210 721000	4830 1090000	YMB	4 0.16	308 12.1	430 16.9	0.34	1.98	2.95	1.94	0.087	680	610	140.1 308.2
23256	280 11.024	500 19.685	176 6.929	3360 756000	5240 1180000	YMB	4 0.16	329 13	450 17.7	0.33	2.07	3.08	2.02	0.092	620	560	149.7 329.3
23260	300 11.811	540 21.26	192 7.559	3840 864000	6150 1380000	YMB	4 0.16	353 13.9	482 19	0.34	2.00	2.98	1.96	0.095	560	510	194.5 427.9
23264	320 12.598	580 22.835	208 8.189	4350 978000	7060 1590000	YMB	4 0.16	379 14.9	516 20.3	0.34	1.98	2.94	1.93	0.101	510	460	245.1 539.2
23268	340 13.386	620 24.409	224 8.819	5160 1160000	8200 1840000	YMB	5 0.2	399 15.7	554 21.8	0.35	1.91	2.84	1.86	0.103	460	420	301.5 663.3
23272	360 14.173	650 25.591	232 9.134	5530 1240000	8790 1980000	YMB	5 0.2	420 16.5	583 22.9	0.35	1.95	2.91	1.91	0.109	430	400	338.6 744.9
23276	380 14.961	680 26.772	240 9.449	5970 1340000	9520 2140000	YMB	5 0.2	442 17.4	611 24.1	0.34	1.98	2.95	1.94	0.11	410	370	379.4 834.7
23280	400 15.748	720 28.347	256 10.079	6720 1510000	10800 2430000	YMB	5 0.2	466 18.4	646 25.4	0.34	1.96	2.93	1.92	0.116	370	340	457.5 1006.5
23284	420 16.535	760 29.921	272 10.709	7360 1650000	11800 2660000	YMB	6 0.24	490 19.3	681 26.8	0.35	1.90	2.83	1.86	0.119	350	320	525.0 1155.0
23288	440 17.323	790 31.102	280 11.024	8090 1820000	13200 2970000	YMB	6 0.24	512 20.1	710 28	0.35	1.95	2.91	1.91	0.123	320	300	602.0 1324.4

⁽¹⁾Maximum shaft or housing fillet radius that bearing corners will clear.

⁽²⁾These factors apply for both inch and metric calculations. See engineering section for instructions on use.

⁽³⁾Geometry constant for Lubrication Life Factor a_{31} is found in the Bearing Ratings section of the Engineering Manual (order no. 10424).

⁽⁴⁾See thermal speed ratings in the Engineering Manual (order no. 10424).

NOTE: Tolerance and shaft diameters are shown in the tables D-2 and D-3 on pages D-5 and D-6 as variances from nominal bearing bore.





SAF SPHERICAL ROLLER BEARING PILLOW BLOCKS

Spherical roller bearing pillow blocks combine rugged cast-iron or steel housings with high-capacity bearings to meet the toughest demands of industry. Each pillow block contains an advanced-design spherical roller bearing with improved geometry and raceway finish for maximized load capacity and service life. Integrated housing and bearing features enhance unit lubrication characteristics. Multiple sealing options protect against contamination.

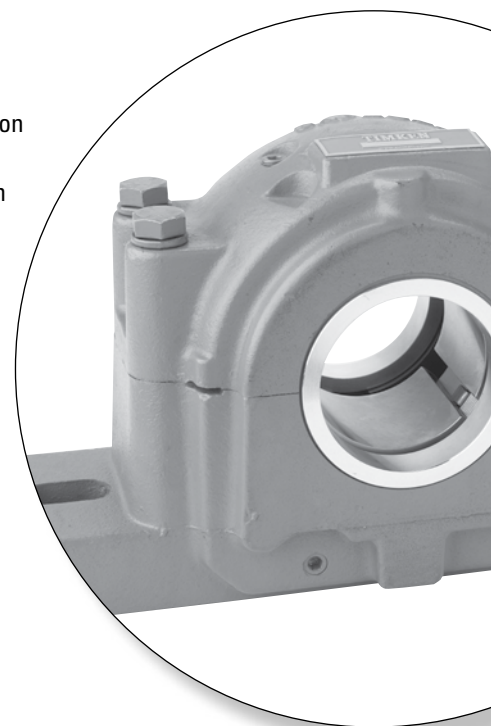

Nomenclature.....	D-46
Introduction.....	D-47
Design and Construction	D-47
Mounting	D-48
Lubrication	D-49
Seals.....	D-49
Load Ratings and Life	D-49
Inch Tapered Bore Mounting	
SAF225 and SAF226 Series.....	D-50
Inch Tapered Bore Mounting	
SDAF225 and SDAF226 Series.....	D-60
Inch Tapered Bore Mounting	
SAF230K, SDAF230K Series	D-64
Inch Tapered Bore Mounting	
SDAF231K and SDAF232K Series	D-68
Inch Straight Bore Mounting	
SAF222 and SAF223 Series.....	D-70
Inch Straight Bore Mounting	
SDAF222 and SDAF223 Series.....	D-72
Inch Straight Bore Mounting	
SDAF231 and SDAF232 Series.....	D-74
Inch Shaft Diameters.....	D-76
Inch TU Take-Up Units Series	D-77
Inch TTU Take-Up Units Series	D-78
Inch DUSTAC™ Shaft Seals.....	D-80
Inch Sine Bar Gages.....	D-81



SAF HOUSED UNIT NOMENCLATURE

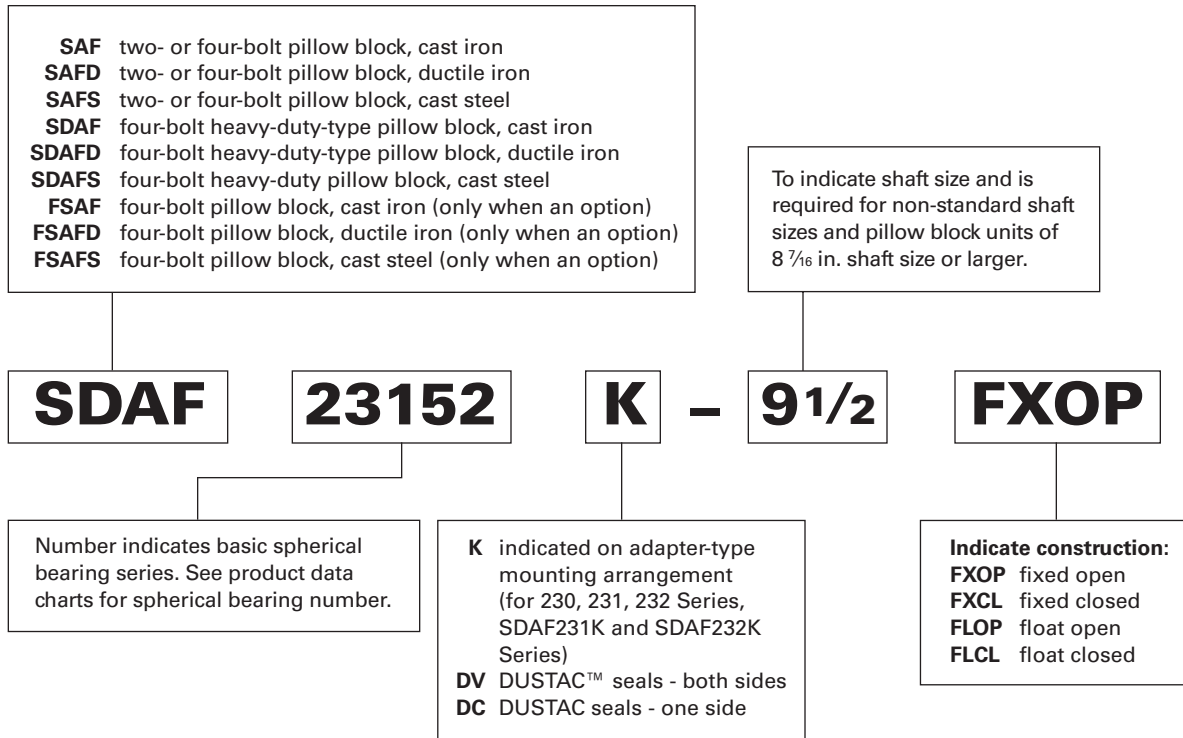

Fig. D-14. Pillow blocks.

SAF HOUSED UNIT INTRODUCTION

Timken’s capabilities in engineering and manufacturing heavy-duty pillow blocks provide important user benefits. In addition, Timken’s worldwide sales organization is staffed with experienced engineers who are available for consultation on any pillow block or bearing application. Our expert engineering assistance also is available for applications involving shaft sizes 1016 mm (40 in.) and larger, such as BOF trunnions, bridge blocks and ball mills. If your design calls for shaft sizes or loads not listed in this catalog, contact your Timken engineer for information about availability of special units.

- **Sizes:** 35-300 mm shafts (1 3/8 up to 11 7/8 in.). Special shaft sizes up to 1000 mm (39 3/8 in.) and beyond.
- **Applications:** Conveyors, ball mills, casters, rolling mills, heavy movable structures.
- **Features:** Split construction for convenient assembly and disassembly. These units include pry tool slots and the exclusive Pry-Lug fulcrum, which simplifies bearing inspection, service and replacement.
- **Benefits:** Caps can be removed easily and quickly without damage to the bearing or housing.

DESIGN AND CONSTRUCTION

Timken supplies pillow blocks equipped with either tapered bore bearings with adapters for mounting on straight shafts or cylindrical bore bearings for assembly on shouldered shafts.

Timken uses a system of doweling caps and bases together at an early stage of manufacturing, so that they remain a single unit during machining. They are not interchangeable as separate parts and become precisely mated components, helping to ensure a precise fit. Timken manufactures pillow blocks in two styles: SAF and SDAF. The larger SDAF block is suggested for extreme-duty applications.

Standard caps and bases are made from high-grade, stress-relieved cast iron. They also are available in cast steel.

All Timken® split pillow blocks are designed for four-bolt mounting. Certain smaller sizes are normally furnished for two-bolt mounting. These assemblies are indicated in the following tables and can be ordered with an optional four-bolt base.

Four cap bolts are used in most Timken pillow blocks in order to equalize the pressure between the cap and the base, helping to prevent lubricant loss.

The illustration below shows all parts of a pillow block assembly that are described throughout this section.



Fig. D-15.

Protects Bearing, Reduces Leaks
Precision triple-ring labyrinth seal and extra-large oil return holes in the housing protect the bearing



Avoids Damage to Bearing and Housing During Inspections
Pry-tool slots allow quick and easy cap removal

Runs Cooler for Longer Bearing Life
Timken® spherical roller bearings, available with either a steel or brass cage, feature optimized internal geometries and improved lubrication distribution. These high-performance bearings allow ±1.5 degree misalignment

Timken® Spherical Roller Bearing

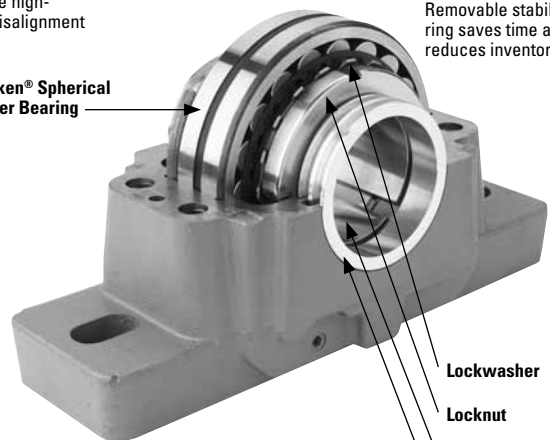

Speed Up Conversion from Fixed to Float Units
Removable stabilizing ring saves time and reduces inventory

Lockwasher
Locknut
Tapered Ring
LER Seal Ring

Shields Bearing
Matched cap and base protect bearing

Fig. D-16. SAF housed unit components and features.

MOUNTING

ADAPTER VERSUS STRAIGHT BORE

Usually a spherical roller bearing pillow block assembly is mounted on a straight shaft using a tapered bore bearing and adapter assembly. Standard commercial shafting can be used without additional machining. (Suggested inch shaft diameters are shown in table D-20 on page D-76.) Adapter mount also permits maximum flexibility in the axial positioning of the bearing on the shaft and will accommodate light locational thrust loads. Timken pillow blocks for tapered bore and adapter-mounted bearings are available in series 225, 226, 230, 231K and 232K.

Adapter-mounted spherical roller bearings require the correct removal of diametral clearance from the bearing to prevent relative rotation between inner race and sleeve or shaft. For proper shaft mounting of adapter-type spherical roller bearings, see page D-7.

When application conditions produce heavy thrust loads, or a need exists for exact axial location or a positive shaft interference fit, a direct straight bore mounting may be the best option. This requires a shouldered shaft, machined for proper fit, and a straight bore bearing. Timken pillow block assemblies for straight bore applications are available in series 222, 223, 231 and 232.

Suggested fits for shafts in cylindrical bore spherical roller bearings are shown in the engineering section of this catalog in table D-4 on page D-9. For applications involving heavy shock, vibration, unbalanced rotating loads or other non-standard conditions, consult your Timken engineer.

FIXED AND FLOAT PILLOW BLOCKS

Any style of Timken split pillow blocks can be easily installed at either the float or fixed position on the shaft. For the fixed position, a stabilizing ring is added between the bearing outer-face ring and the housing shoulder to positively locate the shaft and prevent axial movement.

Some applications require centering of the bearing in its housing. To accomplish this, two special-width stabilizing rings can be ordered.

In the float position, the ring is not used, allowing the bearing to move axially (a maximum of $\frac{3}{8}$ in.) to compensate for thermal expansion or contraction of the shaft.

Pillow blocks ordered by the numbers in the dimension tables are fixed units. To order float units, specify by adding suffix float or FL to the pillow block number.

CLOSED-END INSTALLATIONS

In some applications, the shaft end is designed to terminate inside the pillow block. For this design, positive fitting end-cap inserts are available to help seal out contaminants and retain lubricant. Timken heavy-duty end plugs include O-rings for positive sealing.

Designers and installers need to make sure the shaft end does not contact the closure. A minimum of $\frac{1}{8}$ in. clearance at maximum thermal expansion is suggested between the end of the shaft and the closure. Dimension Y in the tables defines the maximum permissible length of the shaft from the centerline of the pillow block housing. If end closure is desired, specify by adding CL (one end closed) to the pillow block assembly number.

NOTE

Failure to employ proper mounting procedures can cause heating and reduced bearing performance.

LUBRICATION

Timken pillow block housings are designed for grease and oil-bath lubrication. They also can be modified easily to accommodate circulating oil- or oil/air-mist systems. Grease fittings or sight gages are available upon request.

A lubrication groove and oil holes are provided in the bearing outer ring. This feature, designated by adding suffix W33 to the bearing number, should be specified whenever re-ordering bearings for pillow blocks. In most cases, the fresh lubricant is fed directly to the center of the bearing between the rows of rollers and distributed to the rest of the bearing. This helps ensure the used lubricant is purged from the bearing.

SEALS

Precision triple-ring labyrinth seals are supplied with all Timken split pillow blocks to help exclude foreign matter and retain lubricants. The pillow block base includes extra-large oil return holes at the bottom of the seal grooves to help prevent leakage past the seals.

For extremely contaminated or abrasive environments, the DUSTAC™ seal offers protection against concentrations of dust or abrasive material that a labyrinth seal cannot keep out. See page D-80 for further information on DUSTAC.

LOAD RATINGS AND LIFE

Load ratings for the spherical roller bearings that are used in pillow blocks are found in the dimension tables on pages D-37 through D-43. Life calculation formulas are found in the Engineering Manual (order no. 10424) on page 48 available on www.timken.com.

In addition to individual bearing selection, the ability of the pillow block to carry the operating load should be considered.

It should be noted that the load rating figures supplied in this catalog are applicable only when the load direction is generally toward the base of the pillow block. If the pillow block must be mounted so the load can be applied in any other direction, consult your Timken engineer.

INCH TAPERED BORE MOUNTING SAF225 AND SAF226 SERIES

- The basic number for ordering complete pillow block assemblies is listed in the table below.
- Each assembly includes the housing cap and base, cap bolts, bearing, bearing adapter, locknut and lockwasher, stabilizing ring and triple-ring seals.
- If only the pillow block housing is desired, use the numbers listed in column headed Housing Only. These units include cap, base, cap bolts, triple-ring seals and stabilizing ring.
- Assemblies and pillow blocks described on this page constitute a fixed unit. To order float units, specify the part number plus the suffix float or FL.
- Assemblies shown are furnished in cast iron. If cast steel is desired, add the letter S to the alpha prefix (e.g., SAFS 22515).
- Four-bolt bases are standard on all assemblies unless as noted.
- If one end closed assembly is required, specify CL in assembly number when ordering.

Pillow Block Assembly ⁽¹⁾	Shaft Dia. S-1 ⁽²⁾	A	B	C	D	E		F	H
						Max.	Min.		
	in.	in.	in.	in.	in.	in.	in.	in.	in.
SERIES SAF225									
SAF22509	1 3/8 1 7/16 1 1/2	2 1/4	8 1/4	2 3/8	13/16	7	6 1/4	–	4 3/8
SAF22510	1 5/8 1 11/16 1 3/4	2 1/2	8 1/4	2 3/8	15/16	7	6 1/2	–	4 3/4
SAF22511	1 7/8 1 15/16 2	2 3/4	9 5/8	2 3/4	15/16	7 7/8	7 3/8	–	5 11/32
SAF22513	2 1/8 2 3/16 2 1/4	3	11	3 1/8	1	9 1/2	8 1/8	–	5 25/32
SAF22515	2 3/8 2 7/16 2 1/2	3 1/4	11 1/4	3 1/8	1 1/8	9 5/8	8 5/8	–	6 3/8
FSAF22515	2 3/8 2 7/16 2 1/2	3 1/4	11 1/4	3 1/8	1 1/8	9 5/8	8 5/8	1 7/8	6 3/8
SAF22516	2 5/8 2 11/16 2 3/4	3 1/2	13	3 1/2	1 3/16	11	9 5/8	–	6 7/8
FSAF22516	2 5/8 2 11/16 2 3/4	3 1/2	13	3 1/2	1 3/16	11	9 5/8	2 1/8	6 7/8
SAF22517	2 13/16 2 7/8 2 15/16 3	3 3/4	13	3 1/2	1 1/4	11	9 7/8	–	7 1/4
FSAF22517	2 13/16 2 7/8 2 15/16 3	3 3/4	13	3 1/2	1 1/4	11	9 7/8	2 1/8	7 1/4

⁽¹⁾ Bold shaft sizes are standard. When ordering non-standard pillow block assemblies specify the shaft size.

⁽²⁾ See page D-76, table D-20 for suggested shaft diameter S-1 tolerances.

⁽³⁾ Includes sleeve, locknut and lockwasher. Add shaft size to order.

⁽⁴⁾ Housing Only includes cap, base, cap bolts, triple-ring seals and stabilizing ring as required. When ordering non-standard housing only, specify the shaft size.

⁽⁵⁾ Stabilizing ring used for fixed (FX) block; do not use for float (FL) mounting.

NOTE: Speed ratings are found in the dimension tables on pages D-37 through D-43.

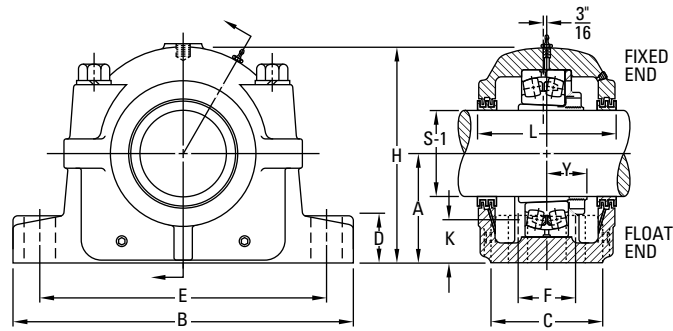

K Oil Level	L	Y	Base Bolts Required		Bearing No.	Adapter Assembly No. ⁽³⁾	Housing Only ⁽⁴⁾	Stabilizing Ring 1 Req'd ⁽⁵⁾	Triple Seal 2 Req'd	Assembly Wt.
			No.	Size						
in.	in.	in.		in.						lbs.
3 ¹ / ₃₂	3 ⁵ / ₁₆	1 ³ / ₃₂	2	1/2	22209K	SNW-09 x 1 ³ / ₈	SAF509	SR-9-9	LER 16	12
						SNW-09 x 1 ⁷/₁₆			LER 17	
						SNW-09 x 1 ¹ / ₂			LER 18	
1 ³ / ₃₂	3 ⁵ / ₁₆	1 ³ / ₃₂	2	1/2	22210K	SNW-10 x 1 ⁵ / ₈	SAF510	SR-10-0	LER 19	13
						SNW-10 x 1 ¹¹/₁₆			LER 20	
						SNW-10 x 1 ³ / ₄			LER 21	
1 ³ / ₁₆	3 ³ / ₄	1 ³ / ₁₆	2	1/2	22211K	SNW-11 x 1 ⁷ / ₈	SAF 511	SR-11-0	LER 23	16
						SNW-11 x 1 ¹⁵/₁₆			LER 24	
						SNW-11 x 2			LER 25	
1 ¹ / ₈	4 ⁵ / ₁₆	1 ⁷ / ₃₂	2	1/2	22213K	SNW-13 x 2 ¹ / ₈	SAF 513	SR-13-0	LER 28	19.5
						SNW-13 x 2 ³/₁₆			LER 29	
						SNW-13 x 2 ¹ / ₄			LER 30	
1 ¹ / ₄	4 ³ / ₄	1 ⁹ / ₃₂	2	5/8	22215K	SNW-15 x 2 ³ / ₈	SAF515	SR-15-0	LER 35	30
						SNW-15 x 2 ⁷/₁₆			LER 37	
						SNW-15 x 2 ¹ / ₂			LER 39	
1 ¹ / ₄	4 ³ / ₄	1 ⁹ / ₃₂	4	1/2	22215K	SNW-15 x 2 ³ / ₈	FSAF515	SR-15-0	LER 35	30
						SNW-15 x 2 ⁷/₁₆			LER 37	
						SNW-15 x 2 ¹ / ₂			LER 39	
1 ¹¹ / ₃₂	4 ⁷ / ₈	1 ²¹ / ₆₄	2	3/4	22216K	SNW-16 x 2 ⁵ / ₈	SAF516	SR-16-13	LER 41	37
						SNW-16 x 2 ¹¹/₁₆			LER 44	
						SNW-16 x 2 ³ / ₄			LER 45	
1 ¹¹ / ₃₂	4 ⁷ / ₈	1 ²¹ / ₆₄	4	5/8	22216K	SNW-16 x 2 ⁵ / ₈	FSAF516	SR-16-13	LER 41	37
						SNW-16 x 2 ¹¹/₁₆			LER 44	
						SNW-16 x 2 ³ / ₄			LER 45	
1 ⁷ / ₁₆	4 ¹⁵ / ₁₆	1 ²⁷ / ₆₄	2	3/4	22217K	SNW-17 x 2 ¹³ / ₁₆	SAF517	SR-17-14	LER 51	40
						SNW-17 x 2 ⁷ / ₈			LER 52	
						SNW-17 x 2 ¹⁵/₁₆			LER 53	
1 ⁷ / ₁₆	4 ¹⁵ / ₁₆	1 ²⁷ / ₆₄	4	5/8	22217K	SNW-17 x 2 ¹³ / ₁₆	FSAF517	SR-17-14	LER 51	40
						SNW-17 x 2 ⁷ / ₈			LER 52	
						SNW-17 x 2 ¹⁵/₁₆			LER 53	
						SNW-17 x 3			LER 54	

⁽¹⁾ Bold shaft sizes are standard. When ordering non-standard pillow block assemblies specify the shaft size.

⁽²⁾ See page D-76, table D-20 for suggested shaft diameter S-1 tolerances.

⁽³⁾ Includes sleeve, locknut and lockwasher. Add shaft size to order.

⁽⁴⁾ Housing Only includes cap, base, cap bolts, triple-ring seals and stabilizing ring as required. When ordering non-standard housing only, specify the shaft size.

⁽⁵⁾ Stabilizing ring used for fixed (FX) block; do not use for float (FL) mounting.

NOTE: Speed ratings are found in the dimension tables on pages D-37 through D-43.

Continued on next page.

INCH TAPERED BORE MOUNTING SAF225 AND SAF226 SERIES – continued

- The basic number for ordering complete pillow block assemblies is listed in the table below.
- Each assembly includes the housing cap and base, cap bolts, bearing, bearing adapter, locknut and lockwasher, stabilizing ring and triple-ring seals.
- If only the pillow block housing is desired, use the numbers listed in column headed Housing Only. These units include cap, base, cap bolts, triple-ring seals and stabilizing ring.
- Assemblies and pillow blocks described on this page constitute a fixed unit. To order float units, specify the part number plus the suffix float or FL.
- Assemblies shown are furnished in cast iron. If cast steel is desired, add the letter S to the alpha prefix (e.g., SAFS 22515).
- Four-bolt bases are standard on all assemblies unless as noted.
- If one end closed assembly is required, specify CL in assembly number when ordering.

Continued from previous page.

Pillow Block Assembly ⁽¹⁾	Shaft Dia. S-1 ⁽²⁾	A	B	C	D	E		F	H
						Max.	Min.		
	in.	in.	in.	in.	in.	in.	in.	in.	in.
SAF22518	3 1/16 3 1/8 3 3/16 3 1/4	4	13 3/4	3 7/8	1 1/2	11 5/8	10 3/8	–	7 3/4
FSAF22518	3 1/16 3 1/8 3 3/16 3 1/4	4	13 3/4	3 7/8	1 1/2	11 5/8	10 3/8	2 1/8	7 3/4
SAF22520	3 3/8 3 7/16 3 1/2	4 1/2	15 1/4	4 3/8	1 3/4	13 1/8	11 5/8	–	8 11/16
FSAF22520	3 3/8 3 7/16 3 1/2	4 1/2	15 1/4	4 3/8	1 3/4	13 1/8	11 5/8	2 3/8	8 11/16
SAF22522	3 13/16 3 7/8 3 15/16 4	4 15/16	16 1/2	4 3/4	2	14 1/2	12 5/8	2 3/4	9 9/16
SAF22524	4 1/16 4 1/8 4 3/16 4 1/4	5 1/4	16 1/2	4 3/4	2 1/8	14 1/2	13 1/4	2 3/4	10 1/4
SAF22526	4 5/16 4 3/8 4 7/16 4 1/2	6	18 3/8	5 1/8	2 3/8	16	14 5/8	3 1/4	11 9/16
SAF22528	4 13/16 4 7/8 4 15/16 5	6	20 1/8	5 7/8	2 3/8	17 1/8	16	3 3/8	11 3/4
SAF22530	5 1/8 5 3/16 5 1/4	6 5/16	21 1/4	6 1/4	2 1/2	18 1/4	17	3 3/4	12 1/2

⁽¹⁾Bold shaft sizes are standard. When ordering non-standard pillow block assemblies specify the shaft size.

⁽²⁾See page D-76, table D-20 for suggested shaft diameter S-1 tolerances.

⁽³⁾Includes sleeve, locknut and lockwasher. Add shaft size to order.

⁽⁴⁾Housing Only includes cap, base, cap bolts, triple-ring seals and stabilizing ring as required. When ordering non-standard housing only, specify the shaft size.

⁽⁵⁾Stabilizing ring used for fixed (FX) block; do not use for float (FL) mounting.

NOTE: Speed ratings are found in the dimension tables on pages D-37 through D-43.

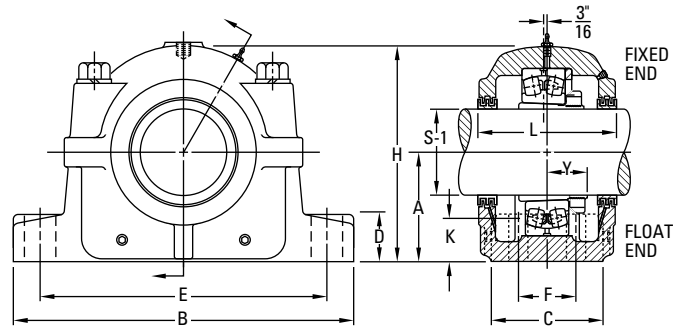

K Oil Level	L	Y	Base Bolts Required		Bearing No.	Adapter Assembly No. ⁽³⁾	Housing Only ⁽⁴⁾	Stabilizing Ring 1 Req'd ⁽⁵⁾	Triple Seal 2 Req'd	Assembly Wt.
			No.	Size						
in.	in.	in.		in.						lbs.
1 17/32	6 1/4	1 37/64	2	3/4	22218K	SNW-18 x 3 1/16	SAF518	SR-18-15	LER 67	49
						SNW-18 x 3 1/8			LER 68	
						SNW-18 x 3 3/16			LER 69	
1 17/32	6 1/4	1 37/64	4	5/8	22218K	SNW-18 x 3 1/16	FSAF518	SR-18-15	LER 70	49
						SNW-18 x 3 1/8			LER 67	
						SNW-18 x 3 3/16			LER 68	
1 3/4	6	1 49/64	2	7/8	22220K	SNW-20 x 3 3/8	SAF520	SR-20-17	LER 101	65
						SNW-20 x 3 7/16			LER 102	
						SNW-20 x 3 1/2			LER 103	
1 3/4	6	1 49/64	4	3/4	22220K	SNW-20 x 3 3/8	FSAF520	SR-20-17	LER 101	65
						SNW-20 x 3 7/16			LER 102	
						SNW-20 x 3 1/2			LER 103	
1 7/8	6 3/8	1 61/64	4	3/4	22222K	SNW-22 x 3 13/16	SAF522	SR-22-19	LER 107	81
						SNW-22 x 3 7/8			LER 108	
						SNW-22 x 3 15/16			LER 109	
1 15/16	7 3/8	2 3/32	4	3/4	22224K	SNW-22 x 4	SAF524	SR-24-20	LER 110	94
						SNW-24 x 4 1/16			LER 111	
						SNW-24 x 4 1/8			LER 112	
2 7/16	8	2 17/64	4	7/8	22226K	SNW-24 x 4 3/16	SAF526	SR-26-0	LER 113	137
						SNW-24 x 4 1/4			LER 114	
						SNW-26 x 4 3/16			LER 115	
2 7/16	8	2 17/64	4	7/8	22226K	SNW-26 x 4 3/8	SAF526	SR-26-0	LER 115	137
						SNW-26 x 4 7/16			LER 117	
						SNW-26 x 4 1/2			LER 118	
2 1/8	7 3/4	2 13/32	4	1	22228K	SNW-28 x 4 13/16	SAF528	SR-28-0	LER 120	159
						SNW-28 x 4 7/8			LER 121	
						SNW-28 x 4 15/16			LER 122	
2 3/16	8 3/8	2 37/64	4	1	22230K	SNW-28 x 5	SAF530	SR-30-0	LER 123	189
						SNW-30 x 5 1/8			LER 124	
						SNW-30 x 5 3/16			LER 125	
						SNW-30 x 5 1/4			LER 126	

⁽¹⁾ Bold shaft sizes are standard. When ordering non-standard pillow block assemblies specify the shaft size.

⁽²⁾ See page D-76, table D-20 for suggested shaft diameter S-1 tolerances.

⁽³⁾ Includes sleeve, locknut and lockwasher. Add shaft size to order.

⁽⁴⁾ Housing Only includes cap, base, cap bolts, triple-ring seals and stabilizing ring as required. When ordering non-standard housing only, specify the shaft size.

⁽⁵⁾ Stabilizing ring used for fixed (FX) block; do not use for float (FL) mounting.

NOTE: Speed ratings are found in the dimension tables on pages D-37 through D-43.

Continued on next page.

INCH TAPERED BORE MOUNTING SAF225 AND SAF226 SERIES – continued

- The basic number for ordering complete pillow block assemblies is listed in the table below.
- Each assembly includes the housing cap and base, cap bolts, bearing, bearing adapter, locknut and lockwasher, stabilizing ring and triple-ring seals.
- If only the pillow block housing is desired, use the numbers listed in column headed Housing Only. These units include cap, base, cap bolts, triple-ring seals and stabilizing ring.
- Assemblies and pillow blocks described on this page constitute a fixed unit. To order float units, specify the part number plus the suffix float or FL.
- Assemblies shown are furnished in cast iron. If cast steel is desired, add the letter S to the alpha prefix (e.g., SAFS 22515).
- Four-bolt bases are standard on all assemblies unless as noted.
- If one end closed assembly is required, specify CL in assembly number when ordering.

Continued from previous page.

Pillow Block Assembly ⁽¹⁾	Shaft Dia. S-1 ⁽²⁾	A	B	C	D	E		F	H
						Max.	Min.		
	in.	in.	in.	in.	in.	in.	in.	in.	in.
SAF22532	5 3/8 5 7/16 5 1/2	6 11/16	22	6 1/4	2 5/8	19 1/4	17 3/8	3 3/4	13 5/16
SAF22534	5 13/16 5 7/8 5 15/16	7 1/16	24 3/4	6 3/4	2 3/4	21 5/8	19 3/8	4 1/4	14 9/16
SAF22536	6 5/16 6 3/8 6 7/16 6 1/2	7 1/2	26 3/4	7 1/8	3	23 5/8	20 7/8	4 5/8	15 1/2
SAF22538	6 13/16 6 7/8 6 15/16 7	7 7/8	28	7 1/2	3 1/8	24 3/8	21 5/8	4 1/2	15 11/16
SAF22540	7 1/8 7 3/16 7 1/4	8 1/4	29 1/2	8	3 3/8	25	22 1/2	5	17 3/16
SAF22544	7 13/16 7 7/8 7 15/16 8	9 1/2	32 3/4	8 3/4	3 3/4	27 7/8	24 3/4	5 1/4	19 5/8
SERIES SAF226									
SAF22615	2 3/8 2 7/16 2 1/2	4	13 3/4	3 7/8	1 5/8	11 5/8	10 3/8	2 1/8	7 9/16
SAF22616	2 5/8 2 11/16 2 3/4	4 1/4	14 1/4	3 7/8	1 3/4	12 5/8	10 5/8	2 1/8	8 1/4

⁽¹⁾ Bold shaft sizes are standard. When ordering non-standard pillow block assemblies specify the shaft size.

⁽²⁾ See page D-76, table D-20 for suggested shaft diameter S-1 tolerances.

⁽³⁾ Includes sleeve, locknut and lockwasher. Add shaft size to order.

⁽⁴⁾ Housing Only includes cap, base, cap bolts, triple-ring seals and stabilizing ring as required. When ordering non-standard housing only, specify the shaft size.

⁽⁵⁾ Stabilizing ring used for fixed (FX) block; do not use for float (FL) mounting.

NOTE: Speed ratings are found in the dimension tables on pages D-37 through D-43.

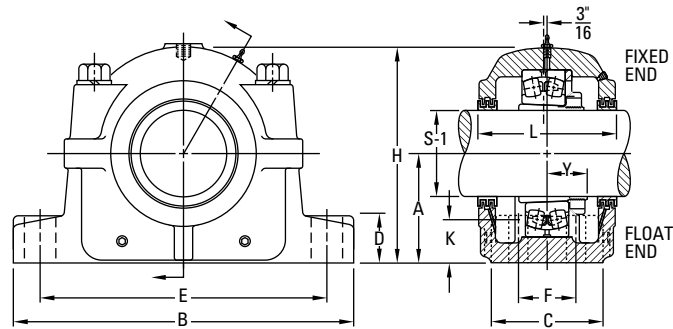

K Oil Level	L	Y	Base Bolts Required		Bearing No.	Adapter Assembly No. ⁽³⁾	Housing Only ⁽⁴⁾	Stabilizing Ring 1 Req'd ⁽⁵⁾	Triple Seal 2 Req'd	Assembly Wt.
			No.	Size						
in.	in.	in.		in.						lbs.
2 3/16	8 3/4	2 49/64	4	1	22232K	SNW-32 x 5 3/8	SAF532	SR-32-0	LER 129	225
						SNW-32 x 5 7/16			LER 130	
						SNW-32 x 5 1/2			LER 131	
2 5/16	9 3/8	2 59/64	4	1	22234K	SNW-34 x 5 13/16	SAF534	SR-34-0	LER 138	300
						SNW-34 x 5 7/8			LER 139	
						SNW-34 x 5 15/16			LER 140	
2 9/16	9 11/16	2 61/64	4	1	22236K	SNW-36 x 6 5/16	SAF536	SR-36-30	LER 146	330
						SNW-36 x 6 3/8			LER 147	
						SNW-36 x 6 7/16			LER 148	
2 5/8	10 3/4	3 7/64	4	1 1/4	22238K	SNW-38 x 6 13/16	SAF538	SR-38-32	LER 153	375
						SNW-38 x 6 7/8			LER 154	
						SNW-38 x 6 15/16			LER 155	
2 11/16	10 13/16	3 9/32	4	1 1/4	22240K	SNW-40 x 7 1/8	SAF540	SR-40-34	LER 158	445
						SNW-40 x 7 3/16			LER 159	
						SNW-40 x 7 1/4			LER 160	
3 3/8	11 1/2	3 17/32	4	1 1/2	22244K	SNW-44 x 7 13/16	SAF544	SR-44-38	LER 165	615
						SNW-44 x 7 7/8			LER 166	
						SNW-44 x 7 15/16			LER 167	
1 19/32	5 7/8	1 7/8	2, 4	3/4, 5/8	22315K	SNW-115 x 2 3/8	SAF 615	SR-18-15	LER 36	52
						SNW-115 x 2 7/16			LER 37	
						SNW-115 x 2 1/2			LER 38	
1 11/16	6 1/2	1 15/16	2, 4	3/4, 5/8	22316K	SNW-116 x 2 5/8	SAF 616	SR-19-16	LER 43	71
						SNW-116 x 2 11/16			LER 44	
						SNW-116 x 2 3/4			LER 45	

⁽¹⁾ Bold shaft sizes are standard. When ordering non-standard pillow block assemblies specify the shaft size.

⁽²⁾ See page D-76, table D-20 for suggested shaft diameter S-1 tolerances.

⁽³⁾ Includes sleeve, locknut and lockwasher. Add shaft size to order.

⁽⁴⁾ Housing Only includes cap, base, cap bolts, triple-ring seals and stabilizing ring as required. When ordering non-standard housing only, specify the shaft size.

⁽⁵⁾ Stabilizing ring used for fixed (FX) block; do not use for float (FL) mounting.

NOTE: Speed ratings are found in the dimension tables on pages D-37 through D-43.

Continued on next page.

INCH TAPERED BORE MOUNTING SAF225 AND SAF226 SERIES – continued

- The basic number for ordering complete pillow block assemblies is listed in the table below.
- Each assembly includes the housing cap and base, cap bolts, bearing, bearing adapter, locknut and lockwasher, stabilizing ring and triple-ring seals.
- If only the pillow block housing is desired, use the numbers listed in column headed Housing Only. These units include cap, base, cap bolts, triple-ring seals and stabilizing ring.
- Assemblies and pillow blocks described on this page constitute a fixed unit. To order float units, specify the part number plus the suffix float or FL.
- Assemblies shown are furnished in cast iron. If cast steel is desired, add the letter S to the alpha prefix (e.g., SAFS 22515).
- Four-bolt bases are standard on all assemblies unless as noted.
- If one end closed assembly is required, specify CL in assembly number when ordering.

Continued from previous page.

Pillow Block Assembly ⁽¹⁾	Shaft Dia. S-1 ⁽²⁾	A	B	C	D	E		F	H
						Max.	Min.		
	in.	in.	in.	in.	in.	in.	in.	in.	in.
SAF22617	2 ¹³ / ₁₆ 2 ⁷ / ₈ 2 ¹⁵/₁₆ 3	4 ¹/₂	15 ¹/₄	4 ³/₈	1 ³/₄	13 ¹/₈	11 ⁵/₈	–	8 ¹¹/₁₆
FSAF22617	2 ¹³ / ₁₆ 2 ⁷ / ₈ 2 ¹⁵/₁₆ 3	4 ¹/₂	15 ¹/₄	4 ³/₈	1 ³/₄	13 ¹/₈	11 ⁵/₈	2 ³/₈	8 ¹¹/₁₆
SAF22618	3 ¹ / ₁₆ 3 ¹ / ₈ 3 ³/₁₆ 3 ¹ / ₄	4 ³/₄	15 ¹/₂	4 ³/₈	2	13 ¹/₂	12	2 ¹/₄	9 ³/₁₆
SAF22620	3 ⁵ / ₁₆ 3 ³ / ₈ 3 ⁷/₁₆ 3 ¹ / ₂	5 ¹/₄	16 ¹/₂	4 ³/₄	2 ¹/₈	14 ¹/₂	13 ¹/₄	2 ³/₄	10 ¹/₄
SAF22622	3 ¹³ / ₁₆ 3 ⁷ / ₈ 3 ¹⁵/₁₆ 4	6	18 ³/₈	5 ¹/₈	2 ³/₈	16	14 ⁵/₈	3 ¹/₄	11 ⁹/₁₆
SAF22624	4 ¹ / ₁₆ 4 ¹ / ₈ 4 ³/₁₆ 4 ¹ / ₄	6 ⁵/₁₆	21 ¹/₄	6 ¹/₄	2 ¹/₂	18 ¹/₄	17	3 ³/₄	12 ¹/₂
SAF22626	4 ⁵ / ₁₆ 4 ³ / ₈ 4 ⁷/₁₆ 4 ¹ / ₂	6 ¹¹/₁₆	22	6 ¹/₄	2 ⁵/₈	19 ¹/₄	17 ³/₈	3 ³/₄	13 ⁵/₁₆
SAF22628	4 ¹³ / ₁₆ 4 ⁷ / ₈ 4 ¹⁵/₁₆ 5	7 ¹/₁₆	24 ³/₄	6 ³/₄	2 ³/₄	21 ⁵/₈	19 ³/₈	4 ¹/₄	14 ⁹/₁₆

⁽¹⁾ Bold shaft sizes are standard. When ordering non-standard pillow block assemblies specify the shaft size.

⁽²⁾ See page D-76, table D-20 for suggested shaft diameter S-1 tolerances.

⁽³⁾ Includes sleeve, locknut and lockwasher. Add shaft size to order.

⁽⁴⁾ Housing Only includes cap, base, cap bolts, triple-ring seals and stabilizing ring as required. When ordering non-standard housing only, specify the shaft size.

⁽⁵⁾ Stabilizing ring used for fixed (FX) block; do not use for float (FL) mounting.

NOTE: Speed ratings are found in the dimension tables on pages D-37 through D-43.

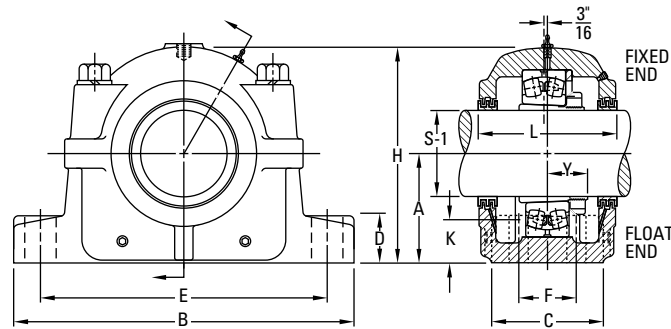

K Oil Level	L	Y	Base Bolts Required		Bearing No.	Adapter Assembly No. ⁽³⁾	Housing Only ⁽⁴⁾	Stabilizing Ring 1 Req'd ⁽⁵⁾	Triple Seal 2 Req'd	Assembly Wt.
			No.	Size						
in.	in.	in.		in.						lbs.
1 13/16	6 5/8	1 57/64	2	7/8	22317K	SNW-117 x 2 13/16	SAF617	SR-20-17	LER 182	81
						SNW-117 x 2 7/8			LER 183	
						SNW-117 x 2 15/16			LER 184	
1 13/16	6 5/8	1 57/64	4	3/4	22317K	SNW-117 x 2 13/16	FSAF617	SR-20-17	LER 182	81
						SNW-117 x 2 7/8			LER 183	
						SNW-117 x 2 15/16			LER 184	
2	7	2 3/64	4	3/4	22318K	SNW-118 x 3 1/16	SAF618	SR-21-18	LER 186	90
						SNW-118 x 3 1/8			LER 187	
						SNW-118 x 3 3/16			LER 188	
2 1/8	7 3/8	2 19/64	4	3/4	22320K	SNW-120 x 3 5/16	SAF620	SR-24-20	LER 100	113
						SNW-120 x 3 3/8			LER 101	
						SNW-120 x 3 7/16			LER 102	
2 1/2	8	2 31/64	4	7/8	22322K	SNW-122 x 3 13/16	SAF622	SR-0-22	LER 107	151
						SNW-122 x 3 7/8			LER 108	
						SNW-122 x 3 15/16			LER 109	
2 3/16	8 3/8	2 41/64	4	1	22324K	SNW-124 x 4 1/16	SAF624	SR-0-24	LER 111	201
						SNW-124 x 4 1/8			LER 112	
						SNW-124 x 4 3/16			LER 113	
2 5/8	8 3/4	2 27/32	4	1	22326K	SNW-126 x 4 5/16	SAF626	SR-0-26	LER 115	245
						SNW-126 x 4 3/8			LER 116	
						SNW-126 x 4 7/16			LER 117	
2 11/16	9 3/8	3 5/64	4	1	22328K	SNW-126 x 4 9/16	SAF628	SR-0-28	LER 118	310
						SNW-126 x 4 1/2			LER 119	
						SNW-128 x 4 13/16			LER 120	
									LER 121	
									LER 122	
									LER 123	

⁽¹⁾ Bold shaft sizes are standard. When ordering non-standard pillow block assemblies specify the shaft size.

⁽²⁾ See page D-76, table D-20 for suggested shaft diameter S-1 tolerances.

⁽³⁾ Includes sleeve, locknut and lockwasher. Add shaft size to order.

⁽⁴⁾ Housing Only includes cap, base, cap bolts, triple-ring seals and stabilizing ring as required. When ordering non-standard housing only, specify the shaft size.

⁽⁵⁾ Stabilizing ring used for fixed (FX) block; do not use for float (FL) mounting.

NOTE: Speed ratings are found in the dimension tables on pages D-37 through D-43.

Continued on next page.

INCH TAPERED BORE MOUNTING SAF225 AND SAF226 SERIES – continued

- The basic number for ordering complete pillow block assemblies is listed in the table below.
- Each assembly includes the housing cap and base, cap bolts, bearing, bearing adapter, locknut and lockwasher, stabilizing ring and triple-ring seals.
- If only the pillow block housing is desired, use the numbers listed in column headed Housing Only. These units include cap, base, cap bolts, triple-ring seals and stabilizing ring.
- Assemblies and pillow blocks described on this page constitute a fixed unit. To order float units, specify the part number plus the suffix float or FL.
- Assemblies shown are furnished in cast iron. If cast steel is desired, add the letter S to the alpha prefix (e.g., SAFS 22515).
- Four-bolt bases are standard on all assemblies unless as noted.
- If one end closed assembly is required, specify CL in assembly number when ordering.

Continued from previous page.

Pillow Block Assembly ⁽¹⁾	Shaft Dia. S-1 ⁽²⁾	A	B	C	D	E		F	H
						Max.	Min.		
	in.	in.	in.	in.	in.	in.	in.	in.	in.
SAF22630	5 1/8 5 3/16 5 1/4	7 1/2	26 3/4	7 1/8	3	23 5/8	20 7/8	4 5/8	15 1/2
SAF22632	5 3/8 5 7/16 5 1/2	7 7/8	28	7 1/2	3 1/8	24 3/8	21 5/8	4 1/2	15 11/16
SAF22634	5 13/16 5 7/8 5 15/16 6	8 1/4	29 1/2	8	3 3/8	25	22 1/2	5	17 3/16
SAF22636	6 7/16 6 13/16 6 7/8 6 15/16 7	8 7/8	31 1/4	8 1/4	3 1/2	26 5/8	24	5 1/4	18 1/2
SAF22638	7 1/8 7 3/16 7 1/4	9 1/2	32 3/4	8 3/4	3 3/4	27 7/8	24 3/4	5 1/4	19 5/8
SAF22640	7 1/8 7 3/16 7 1/4	9 7/8	34 1/4	9	4	29 1/2	26 1/4	5 1/2	20 3/16

⁽¹⁾Bold shaft sizes are standard. When ordering non standard pillow block assemblies specify the shaft size.

⁽²⁾See page D-76, table D-20 for suggested shaft diameter S-1 tolerances.

⁽³⁾Includes sleeve, locknut and lockwasher. Add shaft size to order.

⁽⁴⁾Housing Only includes cap, base, cap bolts, triple-ring seals and stabilizing ring as required. When ordering non-standard housing only, specify the shaft size.

⁽⁵⁾Stabilizing ring used for fixed (FX) block; do not use for float (FL) mounting.

NOTE: Speed ratings are found in the dimension tables on pages D-37 through D-43.

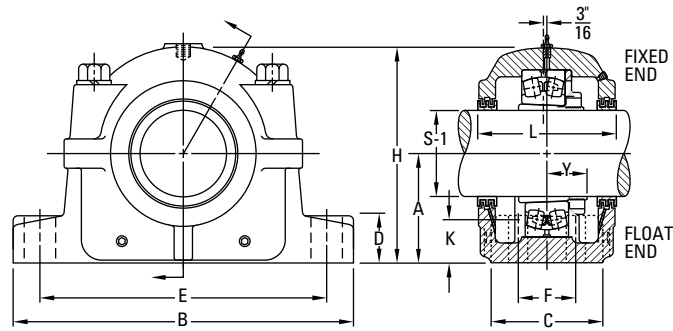

K Oil Level	L	Y	Base Bolts Required		Bearing No.	Adapter Assembly No. ⁽³⁾	Housing Only ⁽⁴⁾	Stabilizing Ring 1 Req'd ⁽⁵⁾	Triple Seal 2 Req'd	Assembly Wt.
			No.	Size						
in.	in.	in.		in.						lbs.
2 7/8	9 11/16	3 17/64	4	1	22330K	SNW-130 x 5 1/8	SAF630	SR-36-30	LER 124	350
						SNW-130 x 5 3/16			LER 125	
						SNW-130 x 5 1/4			LER 126	
2 15/16	10 3/4	3 7/16	4	1 1/4	22332K	SNW-132 x 5 3/8	SAF632	SR-38-32	LER 129	420
						SNW-132 x 5 7/16			LER 130	
						SNW-132 x 5 1/2			LER 131	
3 1/16	10 19/16	3 19/32	4	1 1/4	22334K	SNW-134 x 5 13/16	SAF634	SR-40-34	LER 138	485
						SNW-134 x 5 7/8			LER 139	
						SNW-134 x 5 15/16			LER 140	
3 3/8	11 1/4	3 47/64	4	1 1/4	22336K	SNW-136 x 6 7/16	SAF636	SR-0-36	LER 141	545
3 11/16	11 1/2	3 57/64	4	1 1/2	22338K	SNW-138 x 6 13/16	SAF638	SR-44-38	LER 153	655
						SNW-138 x 6 7/8			LER 154	
						SNW-138 x 6 15/16			LER 155	
						SNW-138 x 7			LER 156	
3 3/4	12 1/4	4 5/64	4	1 1/2	22340K	SNW-140 x 7 1/8	SAF640	SR-0-40	LER 158	725
						SNW-140 x 7 3/16			LER 159	
						SNW-140 x 7 1/4			LER 160	

⁽¹⁾Bold shaft sizes are standard. When ordering non-standard pillow block assemblies specify the shaft size.

⁽²⁾See page D-76, table D-20 for suggested shaft diameter S-1 tolerances.

⁽³⁾Includes sleeve, locknut and lockwasher. Add shaft size to order.

⁽⁴⁾Housing Only includes cap, base, cap bolts, triple-ring seals and stabilizing ring as required. When ordering non-standard housing only, specify the shaft size.

⁽⁵⁾Stabilizing ring used for fixed (FX) block; do not use for float (FL) mounting.

NOTE: Speed ratings are found in the dimension tables on pages D-37 through D-43.

INCH TAPERED BORE MOUNTING SDAF225 AND SDAF226 SERIES

- Each assembly includes the housing cap and base, cap bolts, bearing, bearing adapter, locknut and lockwasher, stabilizing ring and triple-ring seals.
- To order pillow block housing only, use the number listed in the Housing Only column. These units include cap, base, cap bolts, triple-ring seals and stabilizing ring.
- Assemblies and pillow blocks described on this page constitute fixed units.
- To order float units, specify the part number plus the suffix float or FL.
- Assemblies shown are furnished in cast iron. If cast steel is desired, add the letter S to the alpha prefix (e.g., SDAFS 22515).

Pillow Block Assembly ⁽¹⁾	Shaft Dia. S-1 ⁽²⁾	A	B	C	D	E		F	H
						Max.	Min.		
	in.	in.	in.	in.	in.	in.	in.	in.	in.
SERIES SDAF225									
SDAF22520	3 3/8 3 7/16 3 1/2	4 1/2	15 1/4	6	1 7/8	13 1/8	11 5/8	3 3/8	8 15/16
SDAF22522	3 13/16 3 7/8 3 15/16 4	4 15/16	16 1/2	6 3/4	2 1/8	14 1/2	12 5/8	4	9 7/8
SDAF22524	4 1/16 4 1/8 4 3/16 4 1/4	5 1/4	16 1/2	6 7/8	2 1/4	14 1/2	13 1/4	4 1/8	10 1/2
SDAF22526	4 5/16 4 3/8 4 7/16 4 1/2	6	18 3/8	7 1/2	2 3/8	16	14 5/8	4 1/2	11 7/8
SDAF22528	4 13/16 4 7/8 4 15/16 5	6	20 1/8	7 1/2	2 3/8	17 1/8	16	4 1/2	12 1/16
SDAF22530	5 1/8 5 3/16 5 1/4	6 5/16	21 1/4	7 7/8	2 1/2	18 1/4	17	4 3/4	12 13/16
SDAF22532	5 3/8 5 7/16 5 1/2	6 11/16	22	8 1/4	2 1/2	19 1/4	17 3/8	5	13 11/16
SDAF22534	5 15/16	7 1/16	24 3/4	9	2 1/2	21 5/8	19 3/8	5 1/2	14 1/4
SDAF22536	6 5/16 6 3/8 6 7/16 6 1/2	7 1/2	26 3/4	9 3/8	2 3/4	23 5/8	20 7/8	5 7/8	15 3/16
SDAF22538	6 15/16	7 7/8	27 5/8	10	3	23 1/2	21 1/2	6 1/4	16 1/4
SDAF22540	7 3/16	8 1/4	28 3/4	10 1/2	3 1/4	25	23	6 3/4	17 7/8
SDAF22544	7 15/16	9 1/2	32	11 1/4	3 1/2	27 7/8	25 5/8	7 1/4	19 1/4

⁽¹⁾ Bold shaft sizes are standard. When ordering non-standard pillow block assemblies, specify the shaft size.

⁽²⁾ See page D-76, table D-20 for suggested shaft diameter S-1 tolerances.

⁽³⁾ Includes sleeve, locknut and lockwasher. Add shaft size to order.

⁽⁴⁾ Housing Only includes cap, base, cap bolts, triple-ring seals and stabilizing ring as required. When ordering non-standard housing only specify the shaft size.

⁽⁵⁾ Stabilizing ring used for fixed (FX) block; do not use for float (FL) mounting.

NOTE: Speed ratings are found in the dimension tables on pages D-37 through D-43.

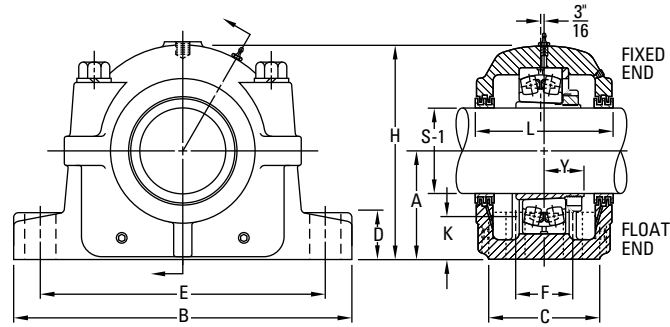

K Oil Level	L	Y	Base Bolts Required		Bearing No.	Adapter Assembly No. ⁽³⁾	Housing Only ⁽⁴⁾	Stabilizing Ring 1 Req'd ⁽⁵⁾	Triple Seal 2 Req'd	Assembly Wt.
			No.	Size						
in.	in.	in.		in.						lbs.
1 3/4	6 3/4	1 49/64	4	3/4	22220K	SNW-20 x 3 3/8 SNW-20 x 3 7/16 SNW-20 x 3 1/2	SDAF520	SR-20-17	LER 74 LER 75 LER 76	81
1 7/8	7 1/4	1 61/64	4	7/8	22222K	SNW-22 x 3 13/16 SNW-22 x 3 7/8 SNW-22 x 3 15/16 SNW-22 x 4	SDAF522	SR-22-19	LER 91 LER 92 LER 93 LER 94	94
1 15/16	7 3/8	2 3/32	4	7/8	22224K	SNW-24 x 4 1/16 SNW-24 x 4 1/8 SNW-24 x 4 3/16 SNW-24 x 4 1/4	SDAF524	SR-24-20	LER 111 LER 112 LER 113 LER 114	137
2 7/16	8	2 17/64	4	1	22226K	SNW-26 x 4 5/16 SNW-26 x 4 3/8 SNW-26 x 4 7/16 SNW-26 x 4 1/2	SDAF526	SR-26-0	LER 115 LER 116 LER 117 LER 118	159
2 1/8	7 13/16	2 13/32	4	1 1/8	22228K	SNW-28 x 4 13/16 SNW-28 x 4 7/8 SNW-28 x 4 15/16 SNW-28 x 5	SDAF528	SR-28-0	LER 120 LER 121 LER 122 LER 123	189
2 3/16	8 3/8	2 37/64	4	1 1/8	22230K	SNW-30 x 5 1/8 SNW-30 x 5 3/16 SNW-30 x 5 1/4	SDAF530	SR-30-0	LER 124 LER 125 LER 126	225
2 3/16	8 3/4	2 49/64	4	1 1/8	22232K	SNW-32 x 5 3/8 SNW-32 x 5 7/16 SNW-32 x 5 1/2	SDAF532	SR-32-0	LER 129 LER 130 LER 131	300
2 5/16	9 5/8	2 59/64	4	1 1/4	22234K	SNW-34 x 5 15/16	SDAF534	SR-34-0	LER 140	310
2 9/16	10	2 61/64	4	1 1/4	22236K	SNW-36 x 6 5/16 SNW-36 x 6 3/8 SNW-36 x 6 7/16 SNW-36 x 6 1/2	SDAF536	SR-36-30	LER 146 LER 147 LER 148 LER 149	350
2 5/8	10 5/8	3 7/64	4	1 3/8	22238K	SNW-38 x 6 15/16	SDAF538	SR-38-32	LER 224	420
2 11/16	11 1/8	3 9/32	4	1 3/8	22240K	SNW-40 x 7 3/16	SDAF540	SR-40-34	LER 228	545
3 3/8	11 7/8	3 17/32	4	1 1/2	22244K	SNW-44 x 7 15/16	SDAF544	SR-44-38	LER 236	665

⁽¹⁾ Bold shaft sizes are standard. When ordering non-standard pillow block assemblies, specify the shaft size.

⁽²⁾ See page D-76, table D-20 for suggested shaft diameter S-1 tolerances.

⁽³⁾ Includes sleeve, locknut and lockwasher. Add shaft size to order.

⁽⁴⁾ Housing Only includes cap, base, cap bolts, triple-ring seals and stabilizing ring as required. When ordering non-standard housing only specify the shaft size.

⁽⁵⁾ Stabilizing ring used for fixed (FX) block; do not use for float (FL) mounting.

NOTE: Speed ratings are found in the dimension tables on pages D-37 through D-43.

Continued on next page.

INCH TAPERED BORE MOUNTING SDAF225 AND SDAF226 SERIES – continued

- Each assembly includes the housing cap and base, cap bolts, bearing, bearing adapter, locknut and lockwasher, stabilizing ring and triple-ring seals.
- To order pillow block housing only, use the number listed in the Housing Only column. These units include cap, base, cap bolts, triple-ring seals and stabilizing ring.
- Assemblies and pillow blocks described on this page constitute fixed units.
- To order float units, specify the part number plus the suffix float or FL.
- Assemblies shown are furnished in cast iron. If cast steel is desired, add the letter S to the alpha prefix (e.g., SAFS 22515).

Continued from previous page.

Pillow Block Assembly ⁽¹⁾	Shaft Dia. S-1 ⁽²⁾	A	B	C	D	E		F	H
						Max.	Min.		
	in.	in.	in.	in.	in.	in.	in.	in.	in.
SERIES SDAF226									
SDAF22617	2 7/8 2 15/16 3	4 1/2	15 1/4	6	1 7/8	13 1/8	11 5/8	3 3/8	8 15/16
SDAF22618	3 1/16 3 1/8 3 3/16 3 1/4	4 3/4	15 1/2	6 1/8	2	13 1/2	12	3 5/8	9 7/16
SDAF22620	3 5/16 3 3/8 3 7/16 3 1/2	5 1/4	16 1/2	6 7/8	2 1/4	14 1/2	13 1/4	4 1/8	10 1/2
SDAF22622	3 13/16 3 7/8 3 15/16 4	6	18 3/8	7 1/2	2 3/8	16	14 5/8	4 1/2	11 7/8
SDAF22624	4 1/16 4 1/8 4 3/16 4 1/4	6 5/16	21 1/4	7 7/8	2 1/2	18 1/4	17	4 3/4	12 13/16
SDAF22626	4 5/16 4 3/8 4 7/16 4 1/2 4 9/16	6 11/16	22	8 1/4	2 1/2	19 1/4	17 3/8	5	13 11/16
SDAF22628	4 15/16	7 1/16	24 3/4	9	2 1/2	21 5/8	19 3/8	5 1/2	14 1/4
SDAF22630	5 1/8 5 3/16 5 1/4 5 3/8 5 5/16	7 1/2	26 3/4	9 3/8	2 3/4	23 5/8	20 7/8	5 7/8	15 3/16
SDAF22632	5 7/16	7 7/8	27 5/8	10	3	23 1/2	21 1/2	6 1/4	16 1/4
SDAF22634	5 15/16	8 1/4	28 3/4	10 1/2	3 1/4	25	23	6 3/4	17 7/8
SDAF22636	6 7/16	8 7/8	30 1/2	10 3/4	3 1/4	26 3/8	24 1/8	6 7/8	17 15/16
SDAF22638	6 15/16	9 1/2	32	11 1/4	3 1/2	27 7/8	25 5/8	7 1/4	19 1/4
SDAF22640	7 3/16	9 7/8	33 1/2	11 3/4	3 1/2	29 1/4	26 5/8	7 5/8	19 15/16

⁽¹⁾Bold shaft sizes are standard. When ordering non-standard pillow block assemblies, specify the shaft size.

⁽²⁾See page D-76, table D-20 for suggested shaft diameter S-1 tolerances.

⁽³⁾Includes sleeve, locknut and lockwasher. Add shaft size to order.

⁽⁴⁾Housing Only includes cap, base, cap bolts, triple-ring seals and stabilizing ring as required. When ordering non-standard housing only specify the shaft size.

⁽⁵⁾Stabilizing ring used for fixed (FX) block; do not use for float (FL) mounting.

NOTE: Speed ratings are found in the dimension tables on pages D-37 through D-43.

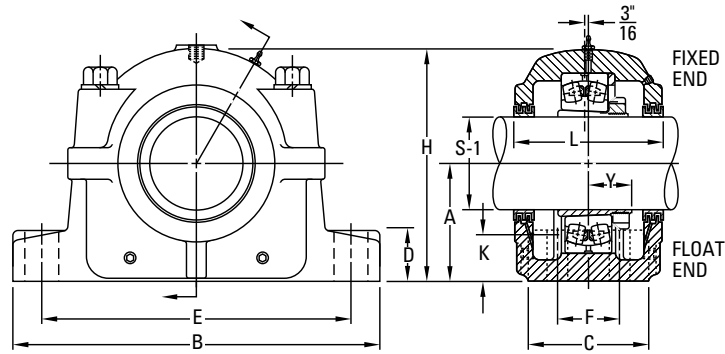

K Oil Level	L	Y	Base Bolts Required		Bearing No.	Adapter Assembly No. ⁽³⁾	Housing Only ⁽⁴⁾	Stabilizing Ring 1 Req'd ⁽⁵⁾	Triple Seal 2 Req'd	Assembly Wt.
			No.	Size						
in.	in.	in.		in.						lbs.
1 13/16	6 3/4	1 57/64	4	3/4	22317K	SNW-117 x 2 7/8	SDAF617	SR-20-17	LER 58	94
						SNW-117 x 2 15/16			LER 59	
						SNW-117 x 3			LER 60	
2	6 7/8	2 3/64	4	3/4	22318K	SNW-118 x 3 1/16	SDAF618	SR-21-18	LER 67	137
						SNW-118 x 3 1/8			LER 68	
						SNW-118 x 3 3/16			LER 69	
2 1/8	7 3/8	2 19/64	4	7/8	22320K	SNW-118 x 3 1/4	SDAF620	SR-24-20	LER 70	159
						SNW-120 x 3 3/16			LER 73	
						SNW-120 x 3 3/8			LER 74	
2 1/2	8	2 31/64	4	1	22322K	SNW-120 x 3 1/2	SDAF622	SR-0-22	LER 75	189
						SNW-122 x 3 13/16			LER 76	
						SNW-122 x 3 7/8			LER 91	
2 5/8	8 3/8	2 41/64	4	1 1/8	22324K	SNW-122 x 4	SDAF624	SR-0-24	LER 92	225
						SNW-124 x 4 1/16			LER 93	
						SNW-124 x 4 1/8			LER 94	
2 5/8	8 3/4	2 27/64	4	1 1/8	22326K	SNW-124 x 4 1/4	SDAF626	SR-0-26	LER 111	300
						SNW-126 x 4 5/16			LER 112	
						SNW-126 x 4 3/8			LER 113	
2 11/16	9 5/8	3 5/64	4	1 1/8	22328K	SNW-126 x 4 1/2	SDAF628	SR-0-28	LER 114	310
						SNW-126 x 4 9/16			LER 115	
						SNW-126 x 4 3/4			LER 116	
2 7/8	9 3/4	3 17/64	4	1 1/4	22330K	SNW-126 x 4 5/8	SDAF630	SR-36-30	LER 117	395
						SNW-130 x 5 1/8			LER 118	
						SNW-130 x 5 1/4			LER 119	
2 15/16	10 5/8	3 7/16	4	1 3/8	22332K	SNW-130 x 5 3/8	SDAF632	SR-38-32	LER 120	420
						SNW-132 x 5 7/16			LER 211	
						SNW-130 x 5 1/2			LER 124	
3 1/16	11 1/8	3 19/32	4	1 3/8	22334K	SNW-130 x 5 5/8	SDAF634	SR-40-34	LER 125	525
						SNW-134 x 5 15/16			LER 126	
						SNW-130 x 5 3/4			LER 127	
3 7/8	11 3/8	3 47/64	4	1 1/2	22336K	SNW-130 x 5 7/8	SDAF636	SR-0-36	LER 128	645
						SNW-136 x 6 7/16			LER 220	
						SNW-130 x 6 1/4			LER 129	
3 11/16	11 13/16	4 57/64	4	1 1/2	22338K	SNW-130 x 6 3/8	SDAF638	SR-44-38	LER 130	705
						SNW-138 x 6 15/16			LER 224	
						SNW-130 x 6 1/2			LER 131	
3 3/4	12 1/4	4 5/64	4	1 5/8	22340K	SNW-130 x 6 5/8	SDAF640	SR-0-40	LER 132	825
						SNW-140 x 7 3/16			LER 228	
						SNW-130 x 6 3/4			LER 133	

⁽¹⁾ Bold shaft sizes are standard. When ordering non-standard pillow block assemblies, specify the shaft size.

⁽²⁾ See page D-76, table D-20 for suggested shaft diameter S-1 tolerances.

⁽³⁾ Includes sleeve, locknut and lockwasher. Add shaft size to order.

⁽⁴⁾ Housing Only includes cap, base, cap bolts, triple-ring seals and stabilizing ring as required. When ordering non-standard housing only specify the shaft size.

⁽⁵⁾ Stabilizing ring used for fixed (FX) block; do not use for float (FL) mounting.

NOTE: Speed ratings are found in the dimension tables on pages D-37 through D-43.

INCH TAPERED BORE MOUNTING SAF230K, SDAF230K SERIES

- Each assembly includes the housing cap and base, cap bolts, bearing, bearing adapter, locknut and lockwasher, stabilizing ring and triple-ring seals.
- If only the pillow block is desired, use the numbers listed in the Housing Only column. These units include cap and base, cap bolts, triple-ring seals and stabilizing ring.
- Assembly and pillow blocks described on this page constitute fixed units.
- To order float units, specify the part number plus the suffix float or FL.
- All assemblies shown are furnished in cast iron. If cast steel is desired, add the letter S to the alpha prefix (e.g., SAFS 23024).
- Please note that for applications SAF23048 and larger, the shaft size must be included in the part description when ordering (e.g., SAF23048-8^{15/16}).
- Two stabilizing rings are supplied with housings SAF048 through SAF056 and SDAF060K through SDAF076K. For fixed applications both rings must be used. Do not use stabilizing rings for float mounting.

Pillow Block Assembly ⁽¹⁾	Shaft Dia. S-1 ⁽²⁾	A	B	C	D	E		F	H	K
						Max.	Min.			
	in.	in.	in.	in.	in.	in.	in.	in.	in.	Oil Level
SERIES SAF230K										
SAF23024K	4 1/16	4 1/2	15 1/4	4 3/8	1 3/4	13 1/8	11 5/8	2 3/8	8 11/16	1 9/16
	4 1/8									
	4 3/16									
SAF23026K	4 5/16	4 15/16	16 1/2	4 3/4	2	14 1/2	12 5/8	2 3/4	9 9/16	1 11/16
	4 3/8									
	4 7/16									
SAF23028K	4 13/16	5 1/4	16 1/2	4 3/4	2 1/8	14 1/2	13 1/4	2 3/4	10 1/4	1 13/16
	4 7/8									
	4 15/16									
SAF23030K	5 1/8	6	18 3/8	5 1/8	2 3/8	16	14 5/8	3 1/4	11 9/16	2 5/16
	5 3/16									
	5 1/4									
SAF23032K	5 3/8	6	18 3/8	5 1/8	2 3/8	16	14 5/8	3 1/4	11 9/16	2 1/16
	5 7/16									
	5 1/2									
SAF23034K	5 13/16	6	20 1/8	5 7/8	2 3/8	17 1/8	16	3 3/8	11 3/4	1 3/4
	5 7/8									
	5 15/16									
SAF23036K	6 5/16	6 11/16	22	6 1/4	2 5/8	19 1/4	17 3/8	3 3/4	13 5/16	2 3/16
	6 3/8									
	6 7/16									
SAF23038K	6 13/16	6 11/16	22	6 1/4	2 5/8	19 1/4	17 3/8	3 3/4	13 5/16	1 15/16
	6 7/8									
	6 15/16									
SAF23040K	7 1/8	7 1/16	24 3/4	6 3/4	2 3/4	21 5/8	19 3/8	4 1/4	14 9/16	2 13/16
	7 3/16									
	7 1/4									
SAF23044K	7 13/16	7 7/8	28	7 1/2	3 1/8	24 3/8	21 5/8	4 1/2	15 11/16	2 3/8
	7 7/8									
	7 15/16									
	8									

⁽¹⁾ Bold shaft sizes are standard. When ordering non-standard pillow block assemblies, specify shaft size.

⁽²⁾ See page D-76, table D-20 for suggested shaft diameter S-1 tolerances.

⁽³⁾ Includes sleeve, locknut and lockwasher. Add shaft size to order.

⁽⁴⁾ Housing Only includes cap, base, cap bolts, triple-ring seals and stabilizing ring as required. When ordering non-standard housing only specify the shaft size.

⁽⁵⁾ Stabilizing ring used for fixed (FX) block; do not use for float (FL) mounting.

NOTE: Speed ratings are found in the dimension tables on pages D-37 through D-43.

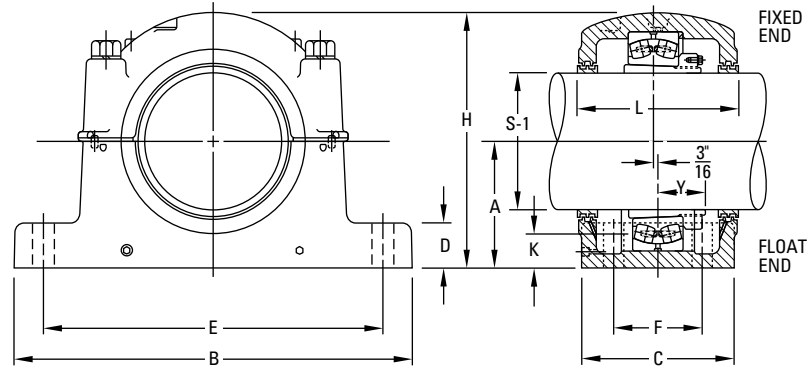

L	Y	Base Bolts 4 Req'd	Bearing No.	Adapter Assembly No. ⁽³⁾	Housing Only ⁽⁴⁾	Stabilizing Ring 1 Req'd ⁽⁵⁾	Triple Seal 2 Req'd	Assembly Wt.
in.	in.	in.						lbs.
6	1 ⁵⁵ / ₆₄	3/4	23024K	SNW-3024 x 4 ¹ / ₁₆ SNW-3024 x 4 ¹ / ₈ SNW-3024 x 4 ³/₁₆ SNW-3024 x 4 ¹ / ₄	SAF024K	SR-20-17	LER 111 LER 112 LER 113 LER 114	60
6 ³ / ₈	2 ¹ / ₃₂	3/4	23026K	SNW-3026 x 4 ⁵ / ₁₆ SNW-3026 x 4 ³ / ₈ SNW-3026 x 4 ⁷/₁₆ SNW-3026 x 4 ¹ / ₂	SAF026K	SR-22-19	LER 115 LER 116 LER 117 LER 118	76
7 ³ / ₈	2 ¹ / ₈	3/4	23028K	SNW-3028 x 4 ¹³ / ₁₆ SNW-3028 x 4 ⁷ / ₈ SNW-3028 x 4 ¹⁵/₁₆ SNW-3028 x 5	SAF028K	SR- 0-20	LER 120 LER 121 LER 122 LER 123	90
8	2 ¹³ / ₆₄	7/8	23030K	SNW-3030 x 5 ¹ / ₈ SNW-3030 x 5 ³/₁₆ SNW-3030 x 5 ¹ / ₄	SAF030K	SR- 0-21	LER 124 LER 125 LER 126	125
8	2 ¹¹ / ₃₂	7/8	23032K	SNW-3032 x 5 ³ / ₈ SNW-3032 x 5 ⁷/₁₆ SNW-3032 x 5 ¹ / ₂	SAF032K	SR- 0-22	LER 129 LER 130 LER 131	132
7 ³ / ₄	2 ²³ / ₆₄	1	23034K	SNW-3034 x 5 ¹³ / ₁₆ SNW-3034 x 5 ⁷ / ₈ SNW-3034 x 5 ¹⁵/₁₆ SNW-3034 x 6	SAF034K	SR- 0-24	LER 138 LER 139 LER 140 LER 141	154
8 ³ / ₄	2 ¹¹ / ₁₆	1	23036K	SNW-3036 x 6 ⁵ / ₁₆ SNW-3036 x 6 ³ / ₈ SNW-3036 x 6 ⁷/₁₆ SNW-3036 x 6 ¹ / ₂	SAF036K	SR- 0-26	LER 146 LER 147 LER 148 LER 149	212
8 ³ / ₄	2 ⁴⁷ / ₆₄	1	23038K	SNW-3038 x 6 ¹³ / ₁₆ SNW-3038 x 6 ⁷ / ₈ SNW-3038 x 6 ¹⁵/₁₆ SNW-3038 x 7	SAF038K	SR-32- 0	LER 153 LER 154 LER 155 LER 156	220
9 ³ / ₈	2 ¹⁵ / ₁₆	1	23040K	SNW-3040 x 7 ¹ / ₈ SNW-3040 x 7 ³/₁₆ SNW-3040 x 7 ¹ / ₄	SAF040K	SR-34- 0	LER 158 LER 159 LER 160	295
10 ³ / ₄	3 ⁵ / ₃₂	1 ¹ / ₄	23044K	SNW-3044 x 7 ¹³ / ₁₆ SNW-3044 x 7 ⁷ / ₈ SNW-3044 x 7 ¹⁵/₁₆ SNW-3044 x 8	SAF044K	SR-38-32	LER 165 LER 166 LER 167 LER 168	370

⁽¹⁾ Bold shaft sizes are standard. When ordering non-standard pillow block assemblies, specify shaft size.

⁽²⁾ See page D-76, table D-20 for suggested shaft diameter S-1 tolerances.

⁽³⁾ Includes sleeve, locknut and lockwasher. Add shaft size to order.

⁽⁴⁾ Housing Only includes cap, base, cap bolts, triple-ring seals and stabilizing ring as required. When ordering non-standard housing only specify the shaft size.

⁽⁵⁾ Stabilizing ring used for fixed (FX) block; do not use for float (FL) mounting.

NOTE: Speed ratings are found in the dimension tables on pages D-37 through D-43.

Continued on next page.

INCH TAPERED BORE MOUNTING SAF230K, SDAF230K SERIES – continued

- Each assembly includes the housing cap and base, cap bolts, bearing, bearing adapter, locknut and lockwasher, stabilizing ring and triple-ring seals.
- If only the pillow block is desired, use the numbers listed in the Housing Only column. These units include cap and base, cap bolts, triple-ring seals and stabilizing ring.
- Assembly and pillow blocks described on this page constitute fixed units.
- To order float units, specify the part number plus the suffix float or FL.
- All assemblies shown are furnished in cast iron. If cast steel is desired, add the letter S to the alpha prefix (e.g., SAFS 23024).
- Please note that for applications SAF23048 and larger, the shaft size must be included in the part description when ordering (e.g., SAF23048-8^{15/16}).
- Two stabilizing rings are supplied with housings SAF048 through SAF056 and SDAF060K through SDAF076K. For fixed applications both rings must be used. Do not use stabilizing rings for float mounting.

Continued from previous page.

Pillow Block Assembly ⁽¹⁾	Shaft Dia. S-1 ⁽²⁾	A	B	C	D	E		F	H	K
						Max.	Min.			
	in.	in.	in.	in.	in.	in.	in.	in.	in.	Oil Level
SAF23048K-8 ^{7/16}	8 ^{7/16}	8 ^{1/4}	29 ^{1/2}	8	3 ^{3/8}	25	22 ^{1/2}	5	17 ^{3/16}	2 ^{1/4}
SAF23048K-8 ^{1/2}	8 ^{1/2}	8 ^{1/4}	29 ^{1/2}	8	3 ^{3/8}	25	22 ^{1/2}	5	17 ^{3/16}	2 ^{1/4}
SAF23048K-8 ^{15/16}	8 ^{15/16}	8 ^{1/4}	29 ^{1/2}	8	3 ^{3/8}	25	22 ^{1/2}	5	17 ^{3/16}	2 ^{1/4}
SAF23048K-9	9	8 ^{1/4}	29 ^{1/2}	8	3 ^{3/8}	25	22 ^{1/2}	5	17 ^{3/16}	2 ^{1/4}
SAF23052K-9 ^{7/16}	9 ^{7/16}	9 ^{1/2}	32 ^{3/4}	8 ^{3/4}	3 ^{3/4}	27 ^{7/8}	24 ^{3/4}	5 ^{1/4}	19 ^{7/16}	2 ^{15/16}
SAF23052K-9 ^{1/2}	9 ^{1/2}	9 ^{1/2}	32 ^{3/4}	8 ^{3/4}	3 ^{3/4}	27 ^{7/8}	24 ^{3/4}	5 ^{1/4}	19 ^{7/16}	2 ^{15/16}
SAF23056K-9 ^{15/16}	9 ^{15/16}	9 ^{7/8}	34 ^{1/4}	9	4	29 ^{1/2}	26 ^{1/4}	5 ^{1/2}	20 ^{3/16}	2 ^{15/16}
SAF23056K-10	10	9 ^{7/8}	34 ^{1/4}	9	4	29 ^{1/2}	26 ^{1/4}	5 ^{1/2}	20 ^{3/16}	2 ^{15/16}
SAF23056K-10 ^{7/16}	10 ^{7/16}	9 ^{7/8}	34 ^{1/4}	9	4	29 ^{1/2}	26 ^{1/4}	5 ^{1/2}	20 ^{3/16}	2 ^{15/16}
SAF23056K-10 ^{1/2}	10 ^{1/2}	9 ^{7/8}	34 ^{1/4}	9	4	29 ^{1/2}	26 ^{1/4}	5 ^{1/2}	20 ^{3/16}	2 ^{15/16}
SERIES SDAF230K										
SDAF23060K-10 ^{15/16}	10 ^{15/16}	12	38 ^{1/4}	14 ^{3/4}	3 ^{1/2}	33 ^{1/2}	32 ^{3/4}	9	23 ^{7/16}	4 ^{7/16}
SDAF23060K-11	11	12	38 ^{1/4}	14 ^{3/4}	3 ^{1/2}	33 ^{1/2}	32 ^{3/4}	9	23 ^{7/16}	4 ^{7/16}
SDAF23064K-11 ^{7/16}	11 ^{7/16}	12	38 ^{1/4}	14 ^{3/4}	3 ^{1/2}	33 ^{1/2}	32 ^{3/4}	9	23 ^{7/16}	4 ^{1/16}
SDAF23064K-11 ^{1/2}	11 ^{1/2}	12	38 ^{1/4}	14 ^{3/4}	3 ^{1/2}	33 ^{1/2}	32 ^{3/4}	9	23 ^{7/16}	4 ^{1/16}
SDAF23064K-11 ^{15/16}	11 ^{15/16}	12	38 ^{1/4}	14 ^{3/4}	3 ^{1/2}	33 ^{1/2}	32 ^{3/4}	9	23 ^{7/16}	4 ^{1/16}
SDAF23064K-12	12	12	38 ^{1/4}	14 ^{3/4}	3 ^{1/2}	33 ^{1/2}	32 ^{3/4}	9	23 ^{7/16}	4 ^{1/16}
SDAF23068K-12 ^{7/16}	12 ^{7/16}	12	39	15 ^{1/4}	4 ^{3/16}	33 ^{1/2}	32	10	24	3 ^{7/16}
SDAF23068K-12 ^{1/2}	12 ^{1/2}	12	39	15 ^{1/4}	4 ^{3/16}	33 ^{1/2}	32	10	24	3 ^{7/16}
SDAF23072K-12 ^{15/16}	12 ^{15/16}	12 ^{13/16}	41 ^{3/4}	15 ^{3/4}	4 ^{1/2}	36 ^{1/2}	35	10 ^{1/2}	26	3 ^{7/8}
SDAF23072K-13	13	12 ^{13/16}	41 ^{3/4}	15 ^{3/4}	4 ^{1/2}	36 ^{1/2}	35	10 ^{1/2}	26	3 ^{7/8}
SDAF23072K-13 ^{7/16}	13 ^{7/16}	12 ^{13/16}	41 ^{3/4}	15 ^{3/4}	4 ^{1/2}	36 ^{1/2}	35	10 ^{1/2}	26	3 ^{7/8}
SDAF23072K-13 ^{1/2}	13 ^{1/2}	12 ^{13/16}	41 ^{3/4}	15 ^{3/4}	4 ^{1/2}	36 ^{1/2}	35	10 ^{1/2}	26	3 ^{7/8}
SDAF23076K-13 ^{15/16}	13 ^{15/16}	12 ^{13/16}	41 ^{3/4}	15 ^{3/4}	4 ^{1/2}	36 ^{1/2}	35	10 ^{1/2}	26	3 ^{7/16}
SDAF23076K-14	14	12 ^{13/16}	41 ^{3/4}	15 ^{3/4}	4 ^{1/2}	36 ^{1/2}	35	10 ^{1/2}	26	3 ^{7/16}
SDAF23080K-15	15	14 ^{1/2}	46	17 ^{1/8}	5 ^{1/4}	40 ^{3/4}	39 ^{1/4}	11	29	4 ^{7/16}
SDAF23084K-15 ^{3/4}	15 ^{3/4}	14 ^{1/2}	46	17 ^{1/8}	5 ^{1/4}	40 ^{3/4}	39 ^{1/4}	11	29	4 ^{1/16}
SDAF23088K-16 ^{1/2}	16 ^{1/2}	15 ^{1/2}	48 ^{3/4}	18 ^{3/4}	5 ^{1/2}	43 ^{1/2}	41 ^{3/4}	12 ^{1/4}	30 ^{1/2}	4 ^{1/2}
SDAF23092K-17	17	15 ^{1/2}	48 ^{3/4}	18 ^{3/4}	5 ^{1/2}	43 ^{1/2}	41 ^{3/4}	12 ^{1/4}	30 ^{1/2}	4
SDAF23096K-18	18	17	53	21	5 ^{1/2}	46 ^{1/8}	44 ^{3/8}	14 ^{1/2}	33 ^{3/4}	5 ^{1/8}
SDAF230/530K-18 ^{1/2}	18 ^{1/2}	17	53	21	5 ^{1/2}	46 ^{1/8}	44 ^{3/8}	14 ^{1/2}	33 ^{3/4}	4 ^{3/4}
SDAF230/530K-19 ^{1/2}	19 ^{1/2}	18	54 ^{1/4}	21 ^{5/8}	5 ^{3/4}	48 ^{7/8}	47 ^{1/8}	15	35 ^{3/4}	4 ^{13/16}

⁽¹⁾ Bold shaft sizes are standard. When ordering non-standard pillow block assemblies, specify shaft size.

⁽²⁾ See page D-76, table D-20 for suggested shaft diameter S-1 tolerances.

⁽³⁾ Includes sleeve, locknut and lockwasher. Add shaft size to order.

⁽⁴⁾ Housing Only includes cap, base, cap bolts, triple-ring seals and stabilizing ring as required. When ordering non-standard housing only specify the shaft size.

⁽⁵⁾ Stabilizing ring used for fixed (FX) block; do not use for float (FL) mounting.

NOTE: Speed ratings are found in the dimension tables on pages D-37 through D-43.

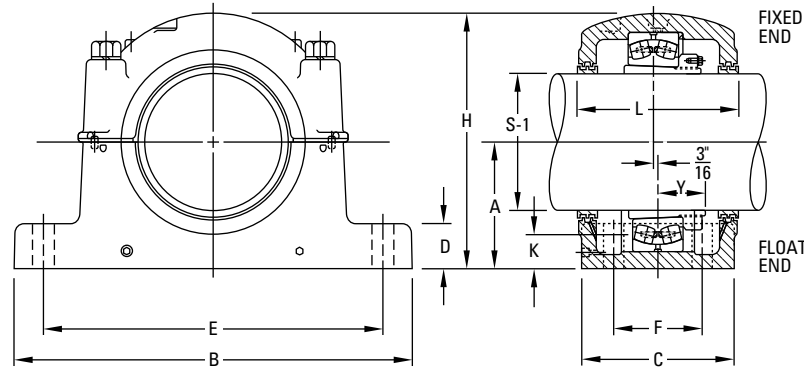

L	Y	Base Bolts 4 Req'd	Bearing No.	Adapter Assembly No. ⁽³⁾	Housing Only ⁽⁴⁾	Stabilizing Ring 1 Req'd ⁽⁵⁾	Triple Seal 2 Req'd	Assembly Wt.
in.	in.	in.						lbs.
11 1/8	3 1/32	1 1/4	23048K	SNP-3048 x 8 7/16	SAF048K-8 7/16	A8897	LER 526	430
11 1/8	3 1/32	1 1/4	23048K	SNP-3048 x 8 1/2	SAF048K-8 1/2	A8897	LER 527	428
11 1/8	3 1/32	1 1/4	23048K	SNP-3048 x 8 15/16	SAF048K-8 15/16	A8897	LER 529	422
11 1/8	3 1/32	1 1/4	23048K	SNP-3048 x 9	SAF048K-9	A8897	LER 530	420
11 7/8	3 5/64	1 1/2	23052K	SNP-3052 x 9 7/16	SAF052K-9 7/16	A8898	LER 178-1	587
11 7/8	3 5/64	1 1/2	23052K	SNP-3052 x 9 1/2	SAF052K-9 1/2	A8898	LER 178	585
12 1/16	3 9/64	1 1/2	23056K	SNP-3056 x 10	SAF056K-9 15/16	A8819	ER 751	640
12 1/16	3 9/64	1 1/2	23056K	SNP-3056 x 10 7/16	SAF056K-10	A8819	ER705	635
12 1/16	3 9/64	1 1/2	23056K	SNP-3056 x 10 1/2	SAF056K-10 1/16	A8819	ER 745	625
12 1/16	3 9/64	1 1/2	23056K	SNP-3056 x 9 15/16	SAF056K-10 1/2	A8819	ER 710	620
15 1/2	4 3/32	1 5/8	23060K	SNP-3060 x 10 15/16	SDAF060K-10 15/16	A8967	ER 858	1175
15 1/2	4 3/32	1 5/8	23060K	SNP-3060 x 11	SDAF060K-11	A8967	ER 825	1174
15 1/2	4 7/16	1 5/8	23064K	SNP-3064 x 11 7/16	SDAF064K-11 7/16	A8968	ER 861	1275
15 1/2	4 7/16	1 5/8	23064K	SNP-3064 x 11 1/2	SDAF064K-11 1/2	A8968	ER 832	1274
15 1/2	4 7/16	1 5/8	23064K	SNP-3064 x 11 15/16	SDAF064K-11 15/16	A8968	ER 859	1269
15 1/2	4 7/16	1 5/8	23064K	SNP-3064 x 12	SDAF064K-12	A8968	ER 818	1268
15 3/4	4 13/16	1 7/8	23068K	SNP-3068 x 12 7/16	SDAF068K-12 7/16	A8969	ER 865	1553
15 3/4	4 13/16	1 7/8	23068K	SNP-3068 x 12 1/2	SDAF068K-12 1/2	A8969	ER 866	1552
16 1/4	4 53/64	1 7/8	23072K	SNP-3072 x 12 15/16	SDAF072K-12 15/16	A8970	ER 869	1632
16 1/4	4 53/64	1 7/8	23072K	SNP-3072 x 13	SDAF072K-13	A8970	ER 846	1630
16 1/4	4 53/64	1 7/8	23072K	SNP-3072 x 13 7/16	SDAF072K-13 7/16	A8970	ER 872	1614
16 1/4	4 53/64	1 7/8	23072K	SNP-3072 x 13 1/2	SDAF072K-13 1/2	A8970	ER 823	1610
16 1/4	5 1/16	1 7/8	23076K	SNP-3076 x 13 15/16	SDAF076K-13 15/16	A8971	ER 875	1687
16 1/4	5 1/16	1 7/8	23076K	SNP-3076 x 14	SDAF076K-14	A8971	ER 876	1685
17 5/8	5 17/32	4, 2	23080K	SNP-3080 x 15	SDAF080K-15	A8974	ER 847	2300
17 5/8	5 3/16	4, 2	23087K	SNP-3084 x 15 3/4	SDAF084K-15 3/4	A8978	ER 885	2300
19 1/4	5 3/4	4, 2 1/4	230994K	SNP-3088 x 16 1/2	SDAF3088K-16 1/2	A8979	ER 958	2550
19 1/4	5 7/8	4, 2 1/4	23082K	SNP-3092 x 17	SDAF3092K-17	A8980	ER 838	2850
21 3/4	5 29/32	4, 2 1/4	23096K	SNP-3096 x 18	SDAF3096K-18	A8984	ER 888	4250
21 3/4	6 1/2	4, 2 1/4	230/500K	SNP-30-500 x 18 1/2	SDAF30-500K-18 1/2	A8976	ER 978	4350
22 1/4	6 7/32	4, 2 1/2	230/530/K	SNP-30-530 x 19 1/2	SDAF 30-530K-19 1/2		ER 926	5200

⁽¹⁾ Bold shaft sizes are standard. When ordering non-standard pillow block assemblies, specify shaft size.

⁽²⁾ See page D-76, table D-20 for suggested shaft diameter S-1 tolerances.

⁽³⁾ Includes sleeve, locknut and lockwasher. Add shaft size to order.

⁽⁴⁾ Housing Only includes cap, base, cap bolts, triple-ring seals and stabilizing ring as required. When ordering non-standard housing only specify the shaft size.

⁽⁵⁾ Stabilizing ring used for fixed (FX) block; do not use for float (FL) mounting.

NOTE: Speed ratings are found in the dimension tables on pages D-37 through D-43.

INCH TAPERED BORE MOUNTING SDAF231K AND SDAF232K SERIES

- Each assembly includes the housing cap and base, cap bolts, bearing, bearing adapter, locknut and lockwasher, stabilizing ring and triple-ring seals.
- To order pillow block housing only, use the numbers listed in the Housing Only column. These units include cap and base, cap bolts, triple-ring seals and stabilizing ring.
- Assembly and pillow blocks described on this page constitute fixed units.
- To order float units, specify part number plus suffix float or FL.
- All assemblies shown are furnished in cast iron. If cast steel is desired, add the letter S to the alpha prefix (e.g., SDAFS 23152K).

Pillow Block Assembly	Shaft Dia. S-1 ⁽¹⁾	A	B	C	D	E		F	H
						Max.	Min.		
	in.	in.	in.	in.	in.	in.	in.	in.	in.
SERIES SDAF231K									
SDAF23152K	9 ⁷ / ₁₆ 9 ¹ / ₂	10 ¹ / ₄	35	13 ¹ / ₈	3 ³ / ₄	30 ¹ / ₂	29	8 ³ / ₄	20 ⁷ / ₈
SDAF23156K	9 ¹⁵ / ₁₆ 10 10 ⁷ / ₁₆ 10 ¹ / ₂	12	38 ¹ / ₄	14 ³ / ₄	3 ³ / ₈	33 ¹ / ₂	32 ³ / ₄	9	23 ⁷ / ₁₆
SDAF23160K	10 ¹⁵ / ₁₆ 11	12	38 ¹ / ₄	14 ³ / ₄	3 ³ / ₈	33 ¹ / ₂	32 ³ / ₄	9	23 ⁷ / ₁₆
SDAF23164K	11 ¹⁵ / ₁₆	12 ¹³ / ₁₆	41 ³ / ₄	15 ³ / ₄	4 ¹ / ₂	36 ¹ / ₂	35	10 ¹ / ₂	25 ³ / ₄
SDAF23168K	12 ⁷ / ₁₆	14	43 ³ / ₄	17 ³ / ₄	5	38 ¹ / ₄	36 ³ / ₄	10 ³ / ₄	27 ⁷ / ₈
SDAF23172K	13 ⁷ / ₁₆ 13 ¹ / ₂	14 ¹ / ₂	46	17 ¹ / ₈	5 ¹ / ₄	40 ³ / ₄	39 ¹ / ₄	11	28 ⁷ / ₈
SDAF23176K	13 ¹⁵ / ₁₆ 14 14 ¹⁵ / ₁₆	14 ¹ / ₂	46	17 ¹ / ₈	5 ¹ / ₄	40 ³ / ₄	39 ¹ / ₄	11	28 ⁷ / ₈
SDAF23180K	15	15 ¹ / ₂	48 ³ / ₄	18 ³ / ₄	5 ¹ / ₂	43 ¹ / ₂	41 ³ / ₄	12 ¹ / ₄	30 ¹ / ₂
SDAF23184K	15 ³ / ₄	17	52	21	5 ¹ / ₂	46 ¹ / ₈	44 ³ / ₈	14 ¹ / ₂	33 ³ / ₄
SDAF23188K	16 ¹ / ₂	17	52	21	5 ¹ / ₂	46 ¹ / ₈	44 ³ / ₈	14 ¹ / ₂	33 ³ / ₄
SDAF23192K	17	18	54 ¹ / ₄	21 ⁵ / ₈	5 ³ / ₄	48 ⁷ / ₈	47 ¹ / ₈	15	35 ³ / ₄
SDAF23196K	18	18	54 ¹ / ₄	21 ⁵ / ₈	5 ³ / ₄	48 ⁷ / ₈	47 ¹ / ₈	15	35 ³ / ₄
SERIES SDAF232K									
SDAF23248K	8 ¹⁵ / ₁₆ 9	10 ¹ / ₄	35	13 ¹ / ₈	3 ³ / ₄	30 ¹ / ₂	29	8 ³ / ₄	20 ⁷ / ₈
SDAF23252K	9 ⁷ / ₁₆ 9 ¹ / ₂	12	38 ¹ / ₄	14 ³ / ₄	3 ³ / ₈	33 ¹ / ₂	32 ³ / ₄	9	23 ⁷ / ₁₆
SDAF23256K	10 ⁷ / ₁₆ 10 ¹ / ₂	12	38 ¹ / ₄	14 ³ / ₄	3 ³ / ₈	33 ¹ / ₂	32 ³ / ₄	9	23 ⁷ / ₁₆
SDAF23260K	10 ¹⁵ / ₁₆ 11	12 ¹³ / ₁₆	41 ³ / ₄	15 ³ / ₄	4 ¹ / ₂	36 ¹ / ₂	35	10 ¹ / ₂	25 ³ / ₄
SDAF23264K	11 ¹⁵ / ₁₆	14	43 ³ / ₄	17 ³ / ₄	5	38 ¹ / ₄	36 ³ / ₄	10 ³ / ₄	27 ⁷ / ₈
SDAF23268K	12 ⁷ / ₁₆	14 ¹ / ₂	46	17 ¹ / ₈	5 ¹ / ₄	40 ³ / ₄	39 ¹ / ₄	11	28 ⁷ / ₈
SDAF23272K	13 ⁷ / ₁₆	15 ¹ / ₂	48 ³ / ₄	18 ³ / ₄	5 ¹ / ₂	43 ¹ / ₂	41 ³ / ₄	12 ¹ / ₄	30 ¹ / ₂
SDAF23276K	13 ¹⁵ / ₁₆	15 ¹ / ₂	48 ³ / ₄	18 ³ / ₄	5 ¹ / ₂	43 ¹ / ₂	41 ³ / ₄	12 ¹ / ₄	30 ¹ / ₂
SDAF23280K	14 ¹⁵ / ₁₆	17	52	21	5 ¹ / ₂	46 ¹ / ₈	44 ³ / ₈	14 ¹ / ₂	33 ³ / ₄
SDAF23284K	15 ³ / ₄	18	54 ¹ / ₄	21 ⁵ / ₈	5 ³ / ₄	48 ⁷ / ₈	47 ¹ / ₈	15	35 ³ / ₄
SDAF23288K	16 ¹ / ₂	18	54 ¹ / ₄	21 ⁵ / ₈	5 ³ / ₄	48 ⁷ / ₈	47 ¹ / ₈	15	35 ³ / ₄

⁽¹⁾Bold shaft sizes are standard. When ordering non-standard pillow block assemblies, specify shaft size.

⁽²⁾See page D-76, table D-20 for suggested shaft diameter S-1 tolerances.

⁽³⁾Includes sleeve, locknut and lockwasher. Add shaft size to order.

⁽⁴⁾Housing Only includes cap, base, cap bolts, triple-ring seals and stabilizing ring as required. When ordering non-standard housing only specify the shaft size.

⁽⁵⁾Stabilizing ring used for fixed (FX) block; do not use for float (FL) mounting.

NOTE: Speed ratings are found in the dimension tables on pages D-37 through D-43.

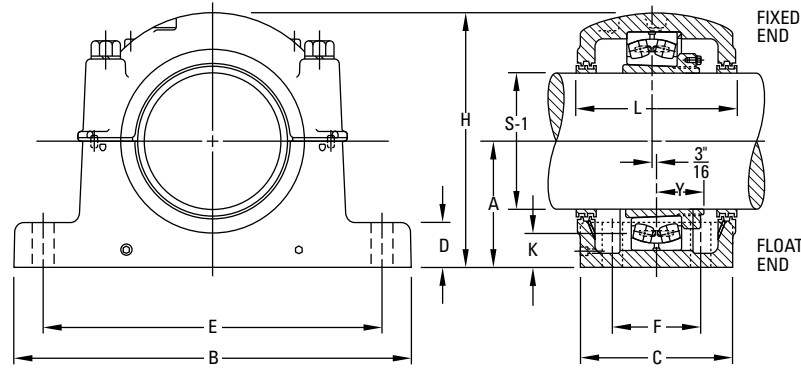

K Oil Level	L	Base Bolts 4 Req'd	Bearing No.	Adapter Assembly No. ⁽³⁾	Housing Only ⁽⁴⁾	Stabilizing Ring 1 Req'd ⁽⁵⁾	Triple Seal 2 Req'd	Assembly Wt.
in.	in.	in.						lbs.
3 3/8	13 3/4	1 5/8	23152K	SNP-3152 x 9 7/16 SNP-3152 x 9 1/2	SDAF3152K	A5679	ER 891 ER 842	1050
4 3/4	15 3/8	1 5/8	23156K	SNP-3156 x 10 SNP-3156 x 10 7/16 SNP-3156 x 10 1/2 SNP-3156 x 9 15/16	SDAF3156K	A8967	ER 845 ER 820 ER 973 ER 840	1300
4 1/8	15 3/8	1 5/8	23160K	SNP-3160 x 10 15/16 SNP-3160 x 11	SDAF3160K	A8975	ER 858 ER 825	1350
4 3/8	16 1/4	1 7/8	23164K	SNP-3164 x 11 15/16	SDAF3164K	A8970	ER 900	1900
4 15/16	18 1/4	2	23168K	SNP-3168 x 12 7/16	SDAF3168K	A8977	ER 975	2550
5	17 3/4	2	23172K	SNP-3172 x 13 7/16 SNP-3172 x 13 1/2	SDAF3172K	A8974	ER 872 ER 823	2600
4 5/8	17 3/4	2	23176K	SNP-3176 x 13 15/16 SNP-3176 x 14 SNP-3180 x 14 15/16	SDAF3176K	A8978	ER 875 ER 876 ER 976	2600
5 1/8	19 1/4	2 1/4	23180K	SNP-3180 x 15	SDAF3180K	A8979	ER 847	3000
6	21 3/4	2 1/4	23184K	SNP-3184 x 15 3/4	SDAF3184K	A8984	ER 907	4400
5 9/16	21 3/4	2 1/4	23188K	SNP-3188 x 16 1/2	SDAF3188K	A8976	ER 958	4600
6	22 1/4	2 1/2	23192K	SNP-3192 x 17	SDAF3192K	A8990	ER 838	5100
5 1/2	22 1/4	2 1/2	23196K	SNP-3196 x 18	SDAF3196K	A8998	ER 888	5200
3 9/16	13 3/4	1 5/8	23248K	SNP-148 x 8 15/16 SNP-148 x 9	SDAF3248K	A5679	ER 914 ER 828	1100
4 3/4	15 3/8	1 5/8	23252K	SNP-152 x 9 7/16 SNP-152 x 9 1/2	SDAF3252K	A8968	ER 891 ER 842	1400
4 3/8	15 3/8	1 5/8	23256K	SNP-3256 x 10 7/16 SNP-3256 x 10 1/2	SDAF3256K	A8975	ER 973 ER 840	1400
4 1/2	16 1/4	1 7/8	23260K	SNP-3260 x 10 15/16 SNP-3260 x 11	SDAF3260K	A8970	ER 974 ER 974-1	1900
5 1/8	18 1/4	2	23264K	SNP-3264 x 11 15/16	SDAF3264K	A8977	ER 900	2600
5	17 3/4	2	23268K	SNP-3268 x 12 7/16	SDAF3268K	A8978	ER 975	2700
5 1/2	19 1/4	2 1/4	23272K	SNP-3272 x 13 7/16	SDAF3272K	A8979	ER 979	3050
4 3/8	19 1/4	2 1/4	23276K	SNP-3276 x 13 15/16	SDAF3276K	A8980	ER 875	3000
6	21 3/4	2 1/4	23280K	SNP-3280 x 14 15/16	SDAF3280K	A8976	ER976	4650
6 3/8	22 1/4	2 1/2	23284K	SNP-3284 x 15 3/4	SDAF3284K	A8990	ER 907	4900
5 7/8	22 1/4	2 1/2	23288K	SNP-3288 x 16 1/2	SDAF3288K	A8988	ER 907	5200

⁽¹⁾ Bold shaft sizes are standard. When ordering non-standard pillow block assemblies, specify shaft size.

⁽²⁾ See page D-76, table D-20 for suggested shaft diameter S-1 tolerances.

⁽³⁾ Includes sleeve, locknut and lockwasher. Add shaft size to order.

⁽⁴⁾ Housing Only includes cap, base, cap bolts, triple-ring seals and stabilizing ring as required. When ordering non-standard housing only specify the shaft size.

⁽⁵⁾ Stabilizing ring used for fixed (FX) block; do not use for float (FL) mounting.

NOTE: Speed ratings are found in the dimension tables on pages D-37 through D-43.

INCH STRAIGHT BORE MOUNTING SAF222 AND SAF223 SERIES

- Each assembly includes the housing cap and base, cap bolts, bearing, locknut and lockwasher, stabilizing ring and triple-ring seals.
- To order pillow block housing only, use the numbers listed in Housing Only column. These units include cap and base, cap bolts, triple-ring seals and stabilizing ring.
- Assembly and pillow blocks described on this page constitute fixed units.
- To order float units, specify part number plus suffix float or FL.
- All assemblies shown are furnished in cast iron. If cast steel is desired, add the letter S to the alpha prefix (e.g., SAFS 22217).
- Four-bolt bases are standard on all assemblies, unless noted.

Pillow Block Assembly	Shaft Dia. ⁽¹⁾		A	B	C	D	E		F	H	K	L	Y	Base Bolts Required		
	S-2	S-3					Max.	Min.						Oil Level	No.	Size
	in.	in.														
SERIES SAF222																
SAF22217	3 15/16	3 3/16	3 3/4	13	3 1/2	1 1/4	11	9 7/8	—	7 1/4	1 7/16	4 15/16	1 27/64	2	3/4	
FSAF22217	3 15/16	3 3/16	3 3/4	13	3 1/2	1 1/4	11	9 7/8	2 1/8	7 1/4	1 7/16	4 15/16	1 27/64	4	5/8	
SAF22218	4 1/8	3 3/8	4	13 3/4	3 7/8	1 1/2	11 5/8	10 3/8	—	7 3/4	1 17/32	6 1/4	1 37/64	2	3/4	
FSAF22218	4 1/8	3 3/8	4	13 3/4	3 7/8	1 1/2	11 5/8	10 3/8	2 1/8	7 3/4	1 17/32	6 1/4	1 37/64	4	5/8	
SAF22220	4 1/2	3 13/16	4 1/2	15 1/4	4 3/8	1 3/4	13 1/8	11 5/8	—	8 11/16	1 3/4	6	1 49/64	2	7/8	
FSAF22220	4 1/2	3 13/16	4 1/2	15 1/4	4 3/8	1 3/4	13 1/8	11 5/8	2 3/8	8 11/16	1 3/4	6	1 49/64	4	3/4	
SAF22222	4 7/8	4 3/16	4 15/16	16 1/2	4 3/4	2	14 1/2	12 5/8	2 3/4	9 9/16	1 7/8	6 3/8	1 61/64	4	3/4	
SAF22224	5 5/16	4 9/16	5 1/4	16 1/2	4 3/4	2 1/8	14 1/2	13 1/4	2 3/4	10 1/4	1 15/16	7 3/8	2 3/32	4	3/4	
SAF22226	5 7/8	4 15/16	6	18 3/8	5 1/8	2 3/8	16	14 3/8	3 1/4	11 1/16	2 7/16	8	2 17/64	4	7/8	
SAF22228	6 1/4	5 5/16	6	20 1/8	5 7/8	2 3/8	17 1/8	16	3 3/8	11 3/4	2 1/8	7 3/4	2 13/32	4	1	
SAF22230	6 5/8	5 3/4	6 5/16	21 1/4	6 1/4	2 1/2	18 1/4	17	3 3/4	12 1/2	2 3/16	8 3/8	2 37/64	4	1	
SAF22232	7	6 1/16	6 11/16	22	6 1/4	2 5/8	19 1/4	17 3/8	3 3/4	13 5/16	2 3/16	8 3/4	2 49/64	4	1	
SAF22234	7 7/16	6 7/16	7 1/16	24 3/4	6 3/4	2 3/4	21 5/8	19 3/8	4 1/4	14 9/16	2 5/16	9 3/8	2 59/64	4	1	
SAF22236	7 13/16	6 7/8	7 1/2	26 3/4	7 1/8	3	23 5/8	20 7/8	4 5/8	15 1/2	2 9/16	9 11/16	2 61/64	4	1	
SAF22238	8 3/8	7 1/4	7 7/8	28	7 1/2	3 1/8	24 3/8	21 5/8	4 1/2	15 11/16	2 5/8	10 3/4	3 7/64	4	1 1/4	
SAF22240	8 3/4	7 5/8	8 1/4	29 1/2	8	3 3/8	25	22 1/2	5	17 3/16	2 11/16	10 13/16	3 3/32	4	1 1/4	
SAF22244	9 9/16	8 5/16	9 1/2	32 3/4	8 3/4	3 3/4	27 7/8	24 3/4	5 1/4	19 5/8	3 3/8	11 1/2	3 17/32	4	1 1/2	
SERIES SAF223																
SAF22317	3 15/16	3 3/16	4 1/2	15 1/4	4 3/8	1 3/4	13 1/8	11 5/8	—	8 11/16	1 13/16	6	1 57/64	2	7/8	
FSAF22317	3 15/16	3 3/16	4 1/2	15 1/4	4 3/8	1 3/4	13 1/8	11 5/8	2 3/8	8 11/16	1 13/16	6	1 57/64	4	3/4	
SAF22318	4 1/8	3 3/8	4 3/4	15 1/2	4 3/8	2	13 1/2	12	2 1/4	9 3/16	2	7	2 3/64	4	3/4	
SAF22320	4 1/2	3 13/16	5 1/4	16 1/2	4 3/4	2 1/8	14 1/2	13 1/4	2 3/4	10 1/4	2 1/8	7 3/8	2 19/64	4	3/4	
SAF22322	4 7/8	4 3/16	6	18 3/8	5 1/8	2 3/8	16	14 3/8	3 1/4	11 9/16	2 1/2	8	2 31/64	4	7/8	
SAF22324	5 5/16	4 9/16	6 5/16	21 1/4	6 1/4	2 1/2	18 1/4	17	3 3/4	12 1/2	2 9/16	8 3/8	2 41/64	4	1	
SAF22326	5 7/8	4 15/16	6 11/16	22	6 1/4	2 5/8	19 1/4	17 3/8	3 3/4	13 15/16	2 5/8	8 3/4	2 27/32	4	1	
SAF22328	6 1/4	5 5/16	7 1/16	24 3/4	6 3/4	2 3/4	21 5/8	19 3/8	4 1/4	14 9/16	2 11/16	9 3/8	3 5/64	4	1	
SAF22330	6 5/8	5 3/4	7 1/2	26 3/4	7 1/8	3	23 5/8	20 7/8	4 5/8	15 1/2	2 7/8	9 11/16	3 17/64	4	1	
SAF22332	7	6 1/16	7 7/8	28	7 1/2	3 1/8	24 3/8	21 5/8	4 1/2	15 11/16	2 15/16	10 3/4	3 7/16	4	1 1/4	
SAF22334	7 7/16	6 7/16	8 1/4	29 1/2	8	3 3/8	25	22 1/2	5	17 3/16	3 1/16	10 13/16	3 19/32	4	1 1/4	
SAF22336	7 13/16	6 7/8	8 7/8	31 1/4	8 1/4	3 1/2	26 5/8	24	5 1/4	18 1/2	3 3/8	11 1/4	3 47/64	4	1 1/4	
SAF22338	8 3/8	7 1/4	9 1/2	32 3/4	8 3/4	3 3/4	27 7/8	24 3/4	5 1/4	19 5/8	3 11/16	11 1/2	3 57/64	4	1 1/2	
SAF22340	8 3/4	7 5/8	9 7/8	34 1/4	9	4	29 1/2	26 1/4	5 1/2	20 3/16	3 3/4	12 1/4	4 5/64	4	1 1/2	

⁽¹⁾See page D-76, table D-20 for suggested shaft diameter S-2, S-3 tolerances.

⁽²⁾Housing Only includes cap, base, cap bolts, triple-ring seals and stabilizing rings as required.

⁽³⁾Stabilizing ring used for fixed (FX) block; do not use for float (FL) mounting.

⁽⁴⁾Triple-ring seals for other shaft diameters are available upon special order.

NOTE: Speed ratings are found in the dimension tables on pages D-37 through D-43.

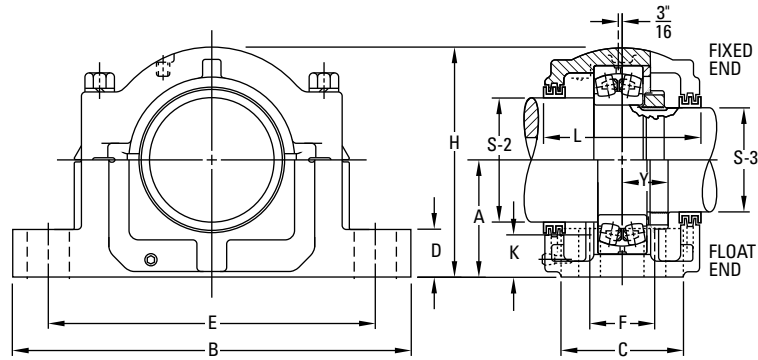

Bearing No.	Locknut	Lockwasher	Housing Only ⁽²⁾	Stabilizing Ring 1 Req'd ⁽³⁾	Triple Seal 1 Req'd ⁽⁴⁾		Assembly Wt.
					S-2	S-3	
							lbs.
22217	AN17	W17	SAF217	SR-17-14	LER89	LER63	43
22217	AN17	W17	FSAF217	SR-17-14	LER89	LER63	43
22218	AN18	W18	SAF218	SR-18-15	LER96	LER72	50
22218	AN18	W18	FSAF218	SR-18-15	LER96	LER72	50
22220	AN20	W20	SAF220	SR-20-17	LER118	LER106	71
22220	AN20	W20	FSAF220	SR-20-17	LER118	LER106	71
22222	AN22	W22	SAF222	SR-22-19	LER121	LER113	81
22224	AN24	W24	SAF224	SR-24-20	LER127	LER119	90
22226	AN26	W26	SAF226	SR-26-0	LER136	LER122	127
22228	AN28	W28	SAF228	SR-28-0	LER144	LER127	149
22230	AN30	W30	SAF230	SR-30-0	LER151	LER134	175
22232	AN32	W32	SAF232	SR-32-0	LER156	LER142	210
22234	AN34	W34	SAF234	SR-34-0	LER161	LER148	280
22236	AN36	W36	SAF236	SR-36-30	LER165	LER154	305
22238	AN38	W38	SAF238	SR-38-32	LER171	LER160	350
22240	AN40	W40	SAF240	SR-40-34	LER175	LER164	420
22244	N44	W44	SAF244	SR-44-38	LER179	LER170	590
22317	AN17	W17	SAF317	SR-20-17	LER109	LER188	80
22317	AN17	W17	FSAF317	SR-20-17	LER109	LER188	80
22318	AN18	W18	SAF318	SR-21-18	LER112	LER191	92
22320	AN20	W20	SAF320	SR-24-20	LER118	LER106	109
22322	AN22	W22	SAF322	SR-0-22	LER121	LER113	145
22324	AN24	W24	SAF324	SR-0-24	LER127	LER119	195
22326	AN26	W26	SAF326	SR-0-26	LER136	LER122	235
22328	AN28	W28	SAF328	SR-0-28	LER144	LER127	300
22330	AN30	W30	SAF330	SR-36-30	LER151	LER134	335
22332	AN32	W32	SAF332	SR-38-32	LER156	LER142	405
22334	AN34	W34	SAF334	SR-40-34	LER161	LER148	465
22336	AN36	W36	SAF336	SR-0-36	LER165	LER154	525
22338	AN38	W38	SAF338	SR-44-38	LER171	LER160	635
22340	AN40	W40	SAF340	SR-0-40	LER175	LER164	700

⁽¹⁾See page D-76, table D-20 for suggested shaft diameter S-2, S-3 tolerances.

⁽²⁾Housing Only includes cap, base, cap bolts, triple-ring seals and stabilizing rings as required.

⁽³⁾Stabilizing ring used for fixed (FX) block; do not use for float (FL) mounting.

⁽⁴⁾Triple-ring seals for other shaft diameters are available upon special order.

NOTE: Speed ratings are found in the dimension tables on pages D-37 through D-43.

INCH STRAIGHT BORE MOUNTING SDAF222 AND SDAF223 SERIES

- Each assembly includes the housing cap and base, cap bolts, bearing, locknut and washer, stabilizing ring, and triple-ring seals.
- To order pillow block housing only, use the numbers listed in the Housing Only column. These units include cap and base, cap bolts, triple-ring seals and stabilizing ring.
- Assembly and pillow blocks described on this page constitute fixed units.
- To order float units, specify part number plus suffix float or FL.
- All assemblies shown are furnished in cast iron. If cast steel is desired, add the letter S to the alpha prefix (e.g., SDAS 22220).

Pillow Block Assembly	Shaft Dia. ⁽¹⁾		A	B	C	D	E		F	H	K	L	Y	Base Bolts Required	
	S-2	S-3					Max.	Min.						No.	Size
	in.	in.													
SERIES SDAF222															
SDAF22220	4 1/2	3 13/16	4 1/2	15 1/4	6	1 7/8	13 1/8	11 5/8	3 3/8	8 15/16	1 3/4	6 3/4	1 49/64	4	3/4
SDAF22222	4 7/8	4 3/16	4 15/16	16 1/2	6 3/4	2 1/8	14 1/2	12 5/8	4	9 7/8	1 7/8	7 1/4	1 81/64	4	7/8
SDAF22224	5 5/16	4 9/16	5 1/4	16 1/2	6 7/8	2 1/4	14 1/2	13 1/4	4 1/8	10 1/2	1 15/16	7 3/8	2 3/32	4	7/8
SDAF22226	5 7/8	4 15/16	6	18 3/8	7 1/2	2 3/8	16	14 3/8	4 1/2	11 7/8	2 7/16	8	2 17/64	4	1
SDAF22228	6 1/4	5 5/16	6	20 1/8	7 1/2	2 3/8	17 1/8	16	4 1/2	12 1/16	2 1/8	7 13/16	2 13/32	4	1
SDAF22230	6 5/8	5 3/4	6 5/16	21 1/4	7 7/8	2 1/2	18 1/4	17	4 3/4	12 13/16	2 3/16	8 3/8	2 37/64	4	1 1/8
SDAF22232	7	6 1/16	6 11/16	22	8 1/4	2 1/2	19 1/4	17 3/8	5	13 11/16	2 3/16	8 3/4	2 49/64	4	1 1/8
SDAF22234	7 7/16	6 7/16	7 1/16	24 3/4	9	2 1/2	21 5/8	19 3/8	5 1/2	14 1/4	2 5/16	9 3/8	2 59/64	4	1 1/4
SDAF22236	7 13/16	6 7/8	7 1/2	26 3/4	9 3/8	2 3/4	23 3/8	20 7/8	5 7/8	15 3/16	2 9/16	10	2 61/64	4	1 1/4
SDAF22238	8 3/8	7 1/4	7 7/8	27 5/8	10	3	23 1/2	21 1/2	6 1/4	16 1/4	2 5/8	10 5/8	3 7/64	4	1 3/8
SDAF22240	8 3/4	7 5/8	8 1/4	28 3/4	10 1/2	3 1/4	25	23	6 3/4	17 7/8	2 11/16	11 1/8	3 9/32	4	1 3/8
SDAF22244	9 9/16	8 5/16	9 1/2	32	11 1/4	3 1/2	27 7/8	25 5/8	7 1/4	19 1/4	3 3/8	11 7/8	3 17/32	4	1 1/2
SERIES SDAF223															
SDAF22317	3 15/16	3 3/16	4 1/2	15 1/4	6	1 7/8	13 1/8	11 5/8	3 3/8	8 15/16	1 3/16	6 3/4	1 57/64	4	3/4
SDAF22318	4 1/8	3 3/8	4 3/4	15 1/2	6 1/8	2	13 1/2	12	3 5/8	9 7/16	2	6 7/8	2 3/64	4	3/4
SDAF22320	4 1/2	3 13/16	5 1/4	16 1/2	6 7/8	2 1/4	14 1/2	13 1/4	4 1/8	10 1/2	2 1/8	7 3/8	2 19/64	4	7/8
SDAF22322	4 7/8	4 3/16	6	18 3/8	7 1/2	2 3/8	16	14 3/8	4 1/2	11 7/8	2 1/2	8	2 31/64	4	1
SDAF22324	5 5/16	4 9/16	6 5/16	21 1/4	7 7/8	2 1/2	18 1/4	17	4 3/4	12 13/16	2 9/16	8 3/8	2 41/64	4	1 1/8
SDAF22326	5 7/8	4 15/16	6 11/16	22	8 1/4	2 1/2	19 1/4	17 3/8	5	13 11/16	2 5/8	8 3/4	2 27/64	4	1 1/8
SDAF22328	6 1/4	5 5/16	7 1/16	24 3/4	9	2 1/2	21 5/8	19 3/8	5 1/2	14 1/4	2 11/16	9 5/8	3 5/64	4	1 1/4
SDAF22330	6 5/8	5 3/4	7 1/2	26 3/4	9 3/8	2 3/4	23 3/8	20 7/8	5 7/8	15 3/16	2 7/8	9 3/4	3 17/64	4	1 1/4
SDAF22332	7	6 1/16	7 7/8	27 5/8	10	3	23 1/2	21 1/2	6 1/4	16 1/4	2 15/16	10 5/8	3 7/16	4	1 3/8
SDAF22334	7 7/16	6 7/16	8 1/4	28 3/4	10 1/2	3 1/4	25	23	6 3/4	17 7/8	3 1/16	11 1/8	3 19/32	4	1 3/8
SDAF22336	7 13/16	6 7/8	8 3/8	30 1/2	10 3/4	3 1/4	26 3/8	24 1/8	6 7/8	17 15/16	3 3/8	11 3/8	3 47/64	4	1 1/2
SDAF22338	8 3/8	7 1/4	9 1/2	32	11 1/4	3 1/2	27 7/8	25 5/8	7 1/4	19 1/4	3 11/16	11 13/16	3 57/64	4	1 1/2
SDAF22340	8 3/4	7 5/8	9 3/8	33 1/2	11 3/4	3 1/2	29 1/4	26 5/8	7 5/8	19 15/16	3 3/4	12 1/4	4 5/64	4	1 5/8

⁽¹⁾See page D-76, table D-20 for suggested shaft diameter S-2, S-3 tolerances.

⁽²⁾Housing Only includes cap, base, cap bolts, triple-ring seals and stabilizing rings as required.

⁽³⁾Stabilizing ring used for fixed (FX) block; do not use for float (FL) mounting.

⁽⁴⁾Triple-ring seals for other shaft diameters are available upon special order.

NOTE: Speed ratings are found in the dimension tables on pages D-37 through D-43.

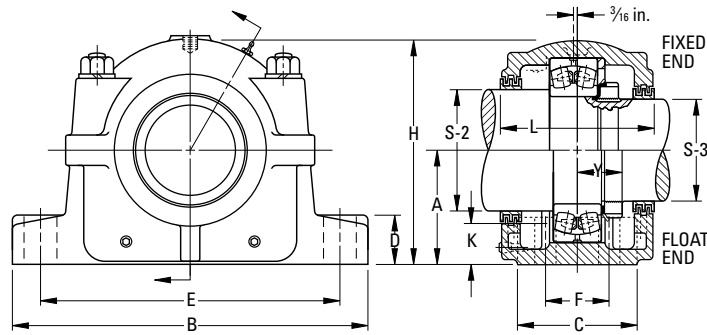

Bearing No.	Locknut	Lockwasher	Housing Only ⁽²⁾	Stabilizing Ring 1 Req'd ⁽³⁾	Triple Seal 1 Req'd ⁽⁴⁾		Assembly Wt. lbs.
					S-2	S-3	
22220	AN20	W20	SDAF220	SR-20-17	LER118	LER106	81
22222	AN22	W22	SDAF222	SR-22-19	LER121	LER113	109
22224	AN24	W24	SDAF224	SR-24-20	LER127	LER119	113
22226	AN26	W26	SDAF226	SR-26-0	LER136	LER122	151
22228	AN28	W28	SDAF228	SR-28-0	LER144	LER127	175
22230	AN30	W30	SDAF230	SR-30-0	LER151	LER134	201
22232	AN32	W32	SDAF232	SR-32-0	LER156	LER142	245
22234	AN34	W34	SDAF234	SR-34-0	LER161	LER148	300
22236	AN36	W36	SDAF236	SR-36-30	LER165	LER154	335
22238	AN38	W38	SDAF238	SR-38-32	LER240	LER229	405
22240	AN40	W40	SDAF240	SR-40-34	LER244	LER233	465
22244	N44	W44	SDAF240	SR-44-38	LER248	LER239	650
22317	AN17	W17	SDAF317	SR-20-17	LER109	LER188	80
22318	AN18	W18	SDAF318	SR-21-18	LER112	LER191	92
22320	AN20	W20	SDAF320	SR-24-20	LER118	LER106	109
22322	AN22	W22	SDAF322	SR-0-22	LER121	LER113	145
22324	AN24	W24	SDAF324	SR-0-24	LER127	LER119	195
22326	AN26	W26	SDAF326	SR-0-26	LER136	LER122	280
22328	AN28	W28	SDAF328	SR-0-28	LER144	LER127	305
22330	AN30	W30	SDAF330	SR-36-30	LER151	LER134	375
22332	AN32	W32	SDAF332	SR-38-32	LER225	LER217	445
22334	AN34	W34	SDAF334	SR-40-34	LER230	LER220	525
22336	AN36	W36	SDAF336	SR-0-36	LER234	LER223	635
22338	AN38	W38	SDAF338	SR-44-38	LER240	LER229	700
22340	AN40	W40	SDAF340	SR-0-40	LER244	LER233	725

⁽¹⁾See page D-76, table D-20 for suggested shaft diameter S-2, S-3 tolerances.
⁽²⁾Housing Only includes cap, base, cap bolts, triple-ring seals and stabilizing rings as required.
⁽³⁾Stabilizing ring used for fixed (FX) block; do not use for float (FL) mounting.
⁽⁴⁾Triple-ring seals for other shaft diameters are available upon special order.
 NOTE: Speed ratings are found in the dimension tables on pages D-37 through D-43.

INCH STRAIGHT BORE MOUNTING SDAF231 AND SDAF232 SERIES

- Each assembly includes the housing cap and base, cap bolts, bearing, locknut and washer, stabilizing ring and triple-ring seals.
- To order pillow block housing only, use the numbers listed in the Housing Only column. These units include cap and base, cap bolts, triple-ring seals and stabilizing ring.
- Assembly and pillow blocks described on this page constitute fixed units.
- To order float units, specify part number plus suffix float or FL.
- Assemblies shown are furnished in cast iron. If cast steel is desired, add the letter S to the alpha prefix. If ductile iron is desired, add the letter D to the alpha prefix (e.g., SAFS 22515 or SAFD 22515).
- For fixed applications, both stabilizing rings must be used. Do not use stabilizing rings for float mounting.

Pillow Block Assembly	Shaft Dia. ⁽¹⁾		A	B	C	D	E		F	H	K	L	
	S-2	S-3					Max.	Min.					Oil Level
	in.	in.											
SERIES SDAF231													
SDAF23152	11 ½	9 15/16	10 ¼	35	13 1/8	3 ¾	30 ½	29	8 ¾	20 7/8	3 ¾	14 ¼	
SDAF23156	12 ½	10 ¾	12	38 ¼	14 ¾	3 ¾	33 ½	32 ¾	9	23 7/16	4 ¾	15 7/8	
SDAF23160	13	11 ½	12	38 ¼	14 ¾	3 ¾	33 ½	32 ¾	9	23 7/16	4 ¾	15 7/8	
SDAF23164	14	12 ¼	12 13/16	41 ¾	15 ¾	4 ½	36 ½	35	10 ½	25 ¾	4 ¾	16 ¾	
SDAF23168	15	13	14	43 ¾	17 ¾	5	38 ¼	36 ¾	10 ¾	27 7/8	4 15/16	18 ¾	
SDAF23172	16	13 ¾	14 ½	46	17 1/8	5 ¼	40 ¾	39 ¼	11	28 7/8	5	18	
SDAF23176	17	14 ½	14 ½	46	17 1/8	5 ¼	40 ¾	39 ¼	11	28 7/8	4 5/8	18	
SDAF23180	17 ½	15 ¼	15 ½	48 ¾	18 ¾	5 ½	43 ½	41 ¾	12 ¼	30 ½	5 1/8	19 ¾	
SDAF23184	18 ½	15 ¾	17	52	21	5 ½	46 1/8	44 3/8	14 ½	33 ¾	6	22 ¼	
SDAF23188	19 ½	17	17	52	21	5 ½	46 1/8	44 3/8	14 ½	33 ¾	5 9/16	22 ¼	
SDAF23192	20	17 ¾	18	54 ¼	21 5/8	5 ¾	48 7/8	47 1/8	15	35 ¾	6	22 ¾	
SERIES SDAF232													
SDAF23248	10 ½	9 3/16	10 ¼	35	13 1/8	3 ¾	30 ½	29	8 ¾	20 7/8	3 9/16	14 ¼	
SDAF23252	11 ½	9 15/16	12	38 ¼	14 ¾	3 ¾	33 ½	32 ¾	9	23 7/16	4 ¾	15 7/8	
SDAF23256	12 ½	10 ¾	12	38 ¼	14 ¾	3 ¾	33 ½	32 ¾	9	23 7/16	4 ¾	15 7/8	
SDAF23260	13	11 ½	12 13/16	41 ¾	15 ¾	4 ½	36 ½	35	10 ½	25 ¾	4 ½	16 ¾	
SDAF23264	14	12 ¼	14	43 ¾	17 ¾	5	38 ¼	36 ¾	10 ¾	27 7/8	5 1/8	18 ¾	
SDAF23268	15	13	14 ½	46	17 1/8	5 ¼	40 ¾	39 ¼	11	28 7/8	5	18	
SDAF23272	16	13 ¾	15 ½	48 ¾	18 ¾	5 ½	43 ½	41 ¾	12 ¼	30 ½	5 1/2	19 ¾	
SDAF23276	17	14 ½	15 ½	48 ¾	18 ¾	5 ½	43 ½	41 ¾	12 ¼	30 ½	4 ¾	19 ¾	
SDAF23280	17 ½	15 ¼	17	52	21	5 ½	46 1/8	44 3/8	14 ½	33 ¾	6	22 ¼	
SDAF23284	18 ½	15 ¾	18	54 ½	21 5/8	5 ¾	48 7/8	47 1/8	15	35 ¾	6 1/8	22 ¾	
SDAF23288	19 ½	17	18	54 ½	21 5/8	5 ¾	48 7/8	47 1/8	15	35 ¾	5 7/8	22 ¾	

⁽¹⁾See page D-76, table D-20 for suggested shaft diameter S-2, S-3 tolerances.

⁽²⁾Housing Only includes cap, base, cap bolts, triple-ring seals and stabilizing rings as required.

⁽³⁾Stabilizing ring used for fixed (FX) block; do not use for float (FL) mounting.

⁽⁴⁾Triple-ring seals for other shaft diameters are available upon special order.

NOTE: Speed ratings are found in the dimension tables on pages D-37 through D-43.

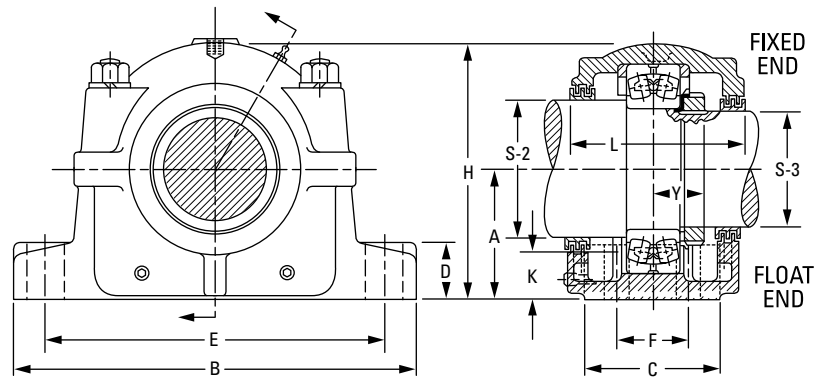

4 Base Bolts Req'd	Bearing No.	Locknut	Lockwasher	Housing Only ⁽²⁾	Stabilizing Ring 1 Req'd ⁽³⁾	Triple Seal 1 Req'd ⁽⁴⁾		Assembly Wt.
						S-2	S-3	
in.								lbs.
1 5/8	23152	N052	P52	SDAF3152	A5679	ER832	ER845	1050
1 5/8	23156	N056	P56	SDAF3156	A8967	ER866	ER826	1250
1 5/8	23160	N060	P60	SDAF3160	A8975	ER824	ER832	1350
1 7/8	23164	N064	P64	SDAF3164	A8970	ER876	ER983	1850
2	23168	N068	P68	SDAF3168	A8977	ER847	ER846	2450
2	23172	N072	P72	SDAF3172	A8974	ER809	ER874	2500
2	23176	N076	P76	SDAF3176	A8978	ER811	ER950	2500
2 1/4	23180	N080	P80	SDAF3180	A8979	ER967	ER895	2800
2 1/4	23184	N084	P84	SDAF3184	A8984	ER978	ER907	4300
2 1/4	23188	N088	P88	SDAF3188	A8976	ER926	ER838	4300
2 1/2	23192	N092	P92	SDAF3192	A8990	ER808	ER906	5000
1 5/8	23248	N048	P48	SDAF3248	A5679	ER840	ER923	1100
1 5/8	23252	N052	P52	SDAF3252	A8968	ER832	ER845	1350
1 5/8	23256	N056	P56	SDAF3256	A8975	ER866	ER826	1400
1 7/8	23260	N060	P60	SDAF3260	A8970	ER846	ER856	1900
2	23264	N064	P64	SDAF3264	A8977	ER876	ER983	2500
2	23268	N068	P68	SDAF3268	A8978	ER847	ER846	2650
2 1/4	23272	N072	P72	SDAF3272	A8979	ER965	ER981	2950
2 1/4	23276	N076	P76	SDAF3276	A8980	ER838	ER984	3050
2 1/4	23280	N080	P80	SDAF3280	A8976	ER967	ER895	4500
2 1/2	23284	N084	P84	SDAF3284	A8990	ER978	ER907	5000
2 1/2	23288	N088	P88	SDAF3288	A8988	ER926	ER838	5050

⁽¹⁾ See page D-76, table D-20 for suggested shaft diameter S-2, S-3 tolerances.
⁽²⁾ Housing Only includes cap, base, cap bolts, triple-ring seals and stabilizing rings as required.
⁽³⁾ Stabilizing ring used for fixed (FX) block; do not use for float (FL) mounting.
⁽⁴⁾ Triple-ring seals for other shaft diameters are available upon special order.

NOTE: Speed ratings are found in the dimension tables on pages D-37 through D-43.

**INCH SHAFT DIAMETERS****TABLE D-20. SUGGESTED S-1, S-2, S-3 INCH SHAFT DIAMETERS**

Diameter	Max.	Min.	Diameter	Max.	Min.
1 1/16	1.4375	1.4345	7 1/4	7.2500	7.2450
1 11/16	1.6875	1.6845	7 7/16	7.4375	7.4325
1 1/8	1.8750	1.8720	7 5/8	7.6250	7.6200
1 15/16	1.9375	1.9345	7 13/16	7.8125	7.8075
2 1/16	2.0625	2.0585	7 15/16	7.9375	7.9325
2 1/8	2.1250	2.1210	8 1/16	8.3125	8.3065
2 3/16	2.1875	2.1835	8 3/8	8.3750	8.3690
2 1/4	2.2500	2.2460	8 7/16	8.4375	8.4315
2 3/8	2.3750	2.3710	8 1/2	8.5000	8.4940
2 7/16	2.4375	2.4335	8 3/4	8.7500	8.7440
2 9/16	2.5625	2.5585	8 15/16	8.9375	8.9315
2 5/8	2.6250	2.6210	9	9.0000	8.9940
2 11/16	2.6875	2.6835	9 1/16	9.4375	9.4315
2 13/16	2.8125	2.8085	9 1/2	9.5000	9.4940
2 7/8	2.8750	2.8710	9 9/16	9.5625	9.5565
2 15/16	2.9375	2.9335	9 15/16	9.9375	9.9315
3	3.0000	2.9960	10	10.0000	9.9940
3 1/16	3.0625	3.0585	10 7/16	10.4375	10.4305
3 3/16	3.1875	3.1835	10 1/2	10.5000	10.4930
3 1/4	3.2500	3.2460	10 15/16	10.9375	10.9305
3 5/8	3.3750	3.3710	11	11.0000	10.9930
3 7/16	3.4375	3.4335	11 1/16	11.4375	11.4305
3 5/8	3.6250	3.6210	11 1/2	11.5000	11.4930
3 15/16	3.9375	3.9335	11 15/16	11.9375	11.9305
4 1/8	4.1250	4.1200	12	12.0000	11.9930
4 3/16	4.1875	4.1825	12 7/16	12.4375	12.4295
4 7/16	4.4375	4.4325	12 1/2	12.5000	12.4920
4 1/2	4.5000	4.4950	12 15/16	12.9375	12.9295
4 9/16	4.5625	4.5575	13	13.0000	12.9920
4 7/8	4.8750	4.8700	13 7/16	13.4375	13.4295
4 15/16	4.9375	4.9325	13 1/2	13.5000	13.4920
5 3/16	5.1875	5.1825	13 15/16	13.9375	13.9295
5 1/8	5.3125	5.3075	14	14.0000	13.9920
5 1/16	5.4375	5.4325	15	15.0000	14.9920
5 3/4	5.7500	5.7450	16	16.0000	15.9920
5 7/8	5.8750	5.8700	17	17.0000	16.9920
5 15/16	5.9375	5.9325	17 1/2	17.5000	17.4920
6 1/16	6.0625	6.0575	18 1/2	18.5000	18.4920
6 1/4	6.2500	6.2450	19 1/2	19.5000	19.4920
6 7/16	6.4375	6.4325	20	20.0000	19.9920
6 5/8	6.6250	6.6200			
6 7/8	6.8750	6.8700			
6 15/16	6.9375	6.9325			
7	7.0000	6.9950			
7 1/16	7.1875	7.1825			

INCH TU TAKE-UP UNITS

- The same care taken in the selection of stationary pillow blocks also must be applied to selecting the proper take-up unit.
- Load requirements should be carefully evaluated before specifying a particular Timken take-up assembly.
- The pedestal is made of stress-relieved cast iron. End bases are made of ductile iron. The guide rail and screw are steel.
- Units are available with travel lengths from 12 to 36 in., in 6-in. increments.
- Catalog numbers shown here are for the TU take-up unit only; pillow block assemblies must be ordered separately.
- Both two- and four-bolt pedestals are available and must be specified.

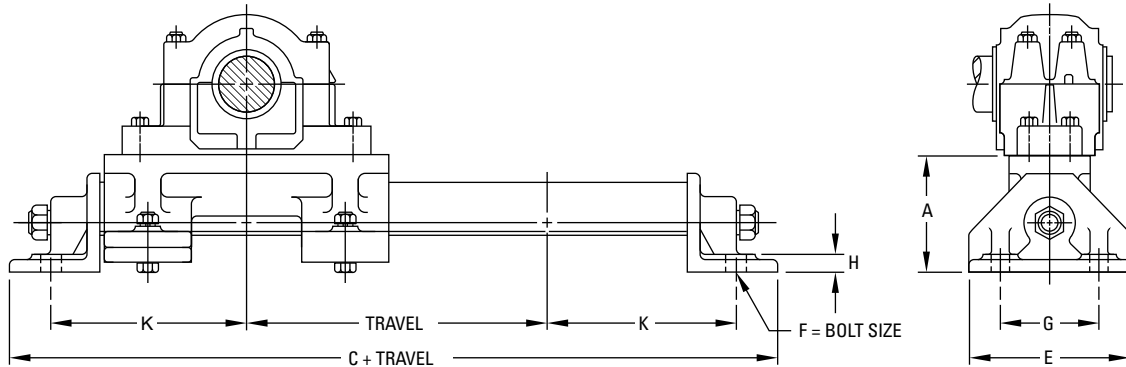

TU Take-Up Unit Catalog No. ⁽¹⁾	Pillow Block Housing No. (SAF or SDAF)			A	C	E	Bolt Size F	G	H	K
				in.	in.	in.	in.	in.	in.	in.
TU-3x	515L	—	—	4 ⁷ / ₈	20	6 ¹ / ₂	⁵ / ₈	4	³ / ₄	8 ¹ / ₄
TU-4x	516L	—	517L	5	21 ³ / ₄	6 ¹ / ₂	³ / ₄	4	³ / ₄	9 ¹ / ₈
TU-5x	518L	—	615L	5 ¹ / ₄	23	7 ¹ / ₂	³ / ₄	5	³ / ₄	9 ³ / ₄
TU-6x	520L	—	617L	5 ¹ / ₂	24 ³ / ₄	7 ¹ / ₂	³ / ₄	5	⁷ / ₈	10 ³ / ₄
TU-7x	522L	524L	620L	6	26	9	³ / ₄	6 ¹ / ₂	1	11 ¹ / ₂
TU-8x	526L	—	622L	6	28	9	³ / ₄	6 ¹ / ₂	1	12 ¹ / ₂
TU-8-1x	528L	—	—	6	29 ¹ / ₂	9	³ / ₄	6 ¹ / ₂	1	13 ¹ / ₄

⁽¹⁾Enter 12, 18, 24, 30 or 36 to indicate travel in inches.



INCH TTU TAKE-UP UNITS

- The same care taken in the selection of stationary pillow blocks also must be applied to selecting the proper take-up unit.
- Load requirements should be carefully evaluated before specifying a particular take-up assembly.
- The frame assembly and adjusting screw of TTU units are made of steel.
- The bearing housing is cast iron. Steel or ductile iron housings are additional options.
- Units include housing for adapter-mounted bearings only, for either fixed or float position (be sure to specify).
- One stabilizing ring is included for fixed-position assemblies.
- Sealing is triple-ring labyrinth or end closures.
- For extremely contaminated environments, the DUSTAC seal is suggested. See page D-80 for more information.

Take-Up Unit and Frame No. (Travel in Bold)	Shaft Dia. S-1 ⁽¹⁾	Bolt Size											
		A	B	C	D	E	F	G	H	L	N	R	T
	in.	in.	in.	in.	in.	in.	in.	in.	in.	in.	in.	in.	in.
TTU-55-12	1 15/16	4 5/8	28 1/2	3 1/2	1 3/4	26 1/2	—	5/8	9	4	3/4	7 1/4	4
TTU-55-18		4 5/8	34 1/2	3 1/2	1 3/4	32 1/2	—	5/8	9	4	3/4	7 1/4	4
TTU-55-24		4 5/8	40 1/2	3 1/2	1 3/4	38 1/2	—	5/8	9	4	3/4	7 1/4	4
TTU-65-12	2 3/16	5	29 1/2	3 1/2	1 3/4	27 1/2	—	5/8	10	4 1/2	3/4	7 3/4	4
TTU-65-18		5	35 1/2	3 1/2	1 3/4	33 1/2	—	5/8	10	4 1/2	3/4	7 3/4	4
TTU-65-24		5	41 1/2	3 1/2	1 3/4	39 1/2	—	5/8	10	4 1/2	3/4	7 3/4	4
TTU-75-6	2 7/16	5 3/16	24 1/2	3 1/2	1 3/4	22 1/2	—	3/4	10 1/2	4 1/2	7/8	8 1/4	4
TTU-75-12		5 3/16	30 1/2	3 1/2	1 3/4	28 1/2	—	3/4	10 1/2	4 1/2	7/8	8 1/4	4
TTU-75-18		5 3/16	36 1/2	3 1/2	1 3/4	34 1/2	—	3/4	10 1/2	4 1/2	7/8	8 1/4	4
TTU-75-24		5 3/16	42 1/2	3 1/2	1 3/4	40 1/2	—	3/4	10 1/2	4 1/2	7/8	8 1/4	4
TTU-75-30		5 3/16	48 1/2	3 1/2	1 3/4	46 1/2	—	3/4	10 1/2	4 1/2	7/8	8 1/4	4
TTU-85-6	2 15/16	6	26 1/2	4 5/8	2	24 1/2	2	5/8	12 1/4	4 3/4	1	9 1/4	5
TTU-85-12		6	32 1/2	4 5/8	2	30 1/2	2	5/8	12 1/4	4 3/4	1	9 1/4	5
TTU-85-18		6	38 1/2	4 5/8	2	36 1/2	2	5/8	12 1/4	4 3/4	1	9 1/4	5
TTU-85-24		6	44 1/2	4 5/8	2	42 1/2	2	5/8	12 1/4	4 3/4	1	9 1/4	5
TTU-85-30		6	50 1/2	4 5/8	2	48 1/2	2	5/8	12 1/4	4 3/4	1	9 1/4	5
TTU-100-12	3 7/16	6 5/8	34 1/4	4 5/8	2	32	2	3/4	13 7/8	6	1 1/8	10	5 1/2
TTU-100-18		6 5/8	40 1/4	4 5/8	2	38	2	3/4	13 7/8	6	1 1/8	10	5 1/2
TTU-100-24		6 5/8	46 1/4	4 5/8	2	44	2	3/4	13 7/8	6	1 1/8	10	5 1/2
TTU-100-30		6 5/8	52 1/4	4 5/8	2	50	2	3/4	13 7/8	6	1 1/8	10	5 1/2
TTU-110-12	3 15/16	7 3/4	38 1/2	5 5/8	2 1/4	36	2 1/2	3/4	16 1/4	6 1/2	1 1/4	12	7
TTU-110-18		7 3/4	44 1/2	5 5/8	2 1/4	42	2 1/2	3/4	16 1/4	6 1/2	1 1/4	12	7
TTU-110-24		7 3/4	50 1/2	5 5/8	2 1/4	48	2 1/2	3/4	16 1/4	6 1/2	1 1/4	12	7
TTU-110-30		7 3/4	56 1/2	5 5/8	2 1/4	54	2 1/2	3/4	16 1/4	6 1/2	1 1/4	12	7
TTU-110-36		7 3/4	62 1/2	5 5/8	2 1/4	60	2 1/2	3/4	16 1/4	6 1/2	1 1/4	12	7
TTU-130-12	4 7/16	8 5/8	45 3/4	8 3/4	2 3/4	40 3/4	5	1 1/8	18 7/8	7 1/4	2	14 3/8	10
TTU-130-18		8 5/8	51 3/4	8 3/4	2 3/4	46 3/4	5	1 1/8	18 7/8	7 1/4	2	14 3/8	10
TTU-130-24		8 5/8	57 3/4	8 3/4	2 3/4	52 3/4	5	1 1/8	18 7/8	7 1/4	2	14 3/8	10
TTU-130-30		8 5/8	63 3/4	8 3/4	2 3/4	58 3/4	5	1 1/8	18 7/8	7 1/4	2	14 3/8	10
TTU-140-12	4 15/16	9 1/2	49 1/2	9 3/4	3	44 1/2	5 1/2	1 1/4	20 3/8	7 1/2	2 1/4	16 1/4	11
TTU-140-18		9 1/2	55 1/2	9 3/4	3	50 1/2	5 1/2	1 1/4	20 3/8	7 1/2	2 1/4	16 1/4	11
TTU-140-24		9 1/2	61 1/2	9 3/4	3	56 1/2	5 1/2	1 1/4	20 3/8	7 1/2	2 1/4	16 1/4	11
TTU-140-30		9 1/2	67 1/2	9 3/4	3	62 1/2	5 1/2	1 1/4	20 3/8	7 1/2	2 1/4	16 1/4	11

⁽¹⁾See page D-76, table D-20 for suggested shaft diameter S-2, S-3 tolerances.

⁽²⁾Includes sleeve, locknut and lockwasher. Add shaft size to order.

⁽³⁾Stabilizing ring is used for fixed (FX) block; do not use for float (FL) mounting.

NOTE: Speed ratings are found in dimension tables on pages D-37 through D-43.

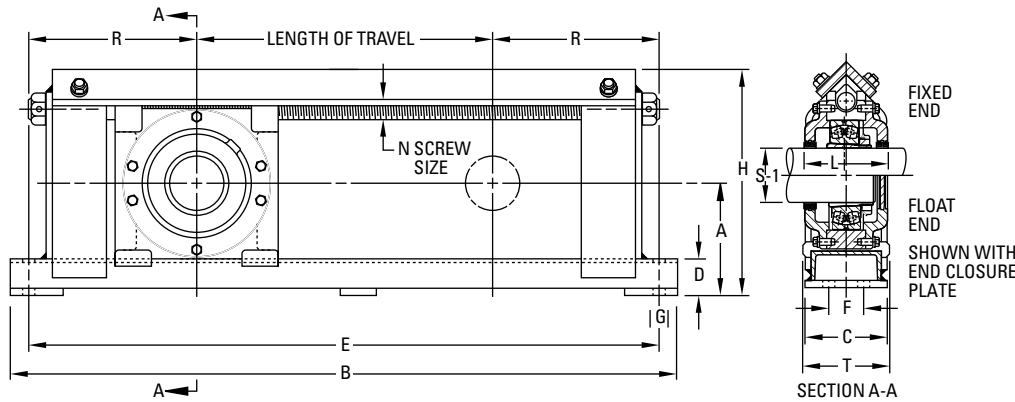

Bearing No.	Adapter Assembly No. ⁽²⁾	Stabilizing Ring 1 Req'd ⁽³⁾	Triple Seal 2 Req'd	Approx. Wt.
				lbs.
22211K	SNW-11	SR-11-0	LER24	55
22211K	SNW-11	SR-11-0	LER24	60
22211K	SNW-11	SR-11-0	LER24	65
22213K	SNW-13	SR-13-0	LER29	60
22213K	SNW-13	SR-13-0	LER29	65
22213K	SNW-13	SR-13-0	LER29	70
22215K	SNW-15	SR-15-0	LER37	65
22215K	SNW-15	SR-15-0	LER37	70
22215K	SNW-15	SR-15-0	LER37	75
22215K	SNW-15	SR-15-0	LER37	80
22215K	SNW-15	SR-15-0	LER37	85
22217K	SNW-17	SR-17-14	LER53	95
22217K	SNW-17	SR-17-14	LER53	100
22217K	SNW-17	SR-17-14	LER53	105
22217K	SNW-17	SR-17-14	LER53	110
22217K	SNW-17	SR-17-14	LER53	115
22220K	SNW-20	SR-20-17	LER102	140
22220K	SNW-20	SR-20-17	LER102	145
22220K	SNW-20	SR-20-17	LER102	150
22220K	SNW-20	SR-20-17	LER102	155
22222K	SNW-22	SR-22-19	LER109	200
22222K	SNW-22	SR-22-19	LER109	210
22222K	SNW-22	SR-22-19	LER109	220
22222K	SNW-22	SR-22-19	LER109	230
22222K	SNW-22	SR-22-19	LER109	240
22226K	SNW-26	SR-26-0	LER117	360
22226K	SNW-26	SR-26-0	LER117	380
22226K	SNW-26	SR-26-0	LER117	400
22226K	SNW-26	SR-26-0	LER117	420
22228K	SNW-28	SR-28-0	LER122	460
22228K	SNW-28	SR-28-0	LER122	480
22228K	SNW-28	SR-28-0	LER122	510
22228K	SNW-28	SR-28-0	LER122	530

⁽¹⁾ See page D-76, table D-20 for suggested shaft diameter S-2, S-3 tolerances.
⁽²⁾ Includes sleeve, locknut and lockwasher. Add shaft size to order.
⁽³⁾ Stabilizing ring is used for fixed (FX) block; do not use for float (FL) mounting.
 NOTE: Speed ratings are found in dimension tables on pages D-37 through D-43.

INCH DUSTAC™ SHAFT SEAL

- Suggested for pillow blocks used in extremely contaminated environments, such as taconite mines.
- Provides protection against residual and airborne contaminants better than the triple-labyrinth shaft seal.

- Contributes significantly to extending service bearing life; reduces costs by helping prevent premature bearing damage.
- Because of its unique design, no special finish is required on the shaft. DUSTAC utilizes a V-shaped nitrile ring that rotates with the shaft and applies pressure to the cartridge face to help exclude contaminants.

TABLE D-21.

Pillow Block Housing No.		Shaft Dia. S-1	Assembly Standout B	DUSTAC™ Seal Assembly	V-Ring Seal	O-Ring	End Plug
500	600						
515	615	2 ⁷ / ₁₆	⁵⁹ / ₆₄	DV-37	V-60-A	2-228	EPS-4
516	616	2 ¹¹ / ₁₆	⁵⁹ / ₆₄	DV-44	V-65-A	2-231	EPS-5
517	—	2 ¹⁵ / ₁₆	1	DV-53	V-75-A	2-230	EPS-6
518	—	3 ³ / ₁₆	1	DV-69	V-80-A	2-235	EPS-9
520	620	3 ⁷ / ₁₆	1	DV-102	V-85-A	2-234	EPS-11
522	622	3 ¹⁵ / ₁₆	1	DV-109	V-100-A	2-239	EPS-13
524	624	4 ³ / ₁₆	1 ¹ / ₁₆	DV-113	V-110-A	2-238	EPS-14
526	626	4 ⁷ / ₁₆	1 ¹ / ₁₆	DV-117	V-110-A	2-242	EPS-15
528	628	4 ¹⁵ / ₁₆	1 ¹ / ₁₆	DV-122	V-130-A	2-244	EPS-16
530	630	5 ³ / ₁₆	1 ¹ / ₁₆	DV-125	V-130-A	2-247	EPS-17
532	632	5 ⁷ / ₁₆	1 ¹ / ₁₆	DV-130	V-140-A	2-249	EPS-18
534	634	5 ¹⁵ / ₁₆	1 ¹ / ₁₆	DV-140	V-150-A	2-253	EPS-20
536	636	6 ⁷ / ₁₆	1 ³ / ₆₄	DV-148	V-160-A	2-259	EPS-21
538	638	6 ¹⁵ / ₁₆	1 ³ / ₆₄	DV-155	V-180-A	2-259	EPS-22
540	640	7 ³ / ₁₆	1 ³ / ₆₄	DV-159	V-180-A	2-259	EPS-23
544	—	7 ¹⁵ / ₁₆	1 ¹⁵ / ₃₂	DV-167	V-200-A	2-262	EPS-25

ORDER INSTRUCTIONS

- Shaft seal may be ordered in place of the standard LER triple-ring seals supplied with the pillow blocks listed. They also are available to retrofit existing installations.
- To order any pillow block housings with DUSTAC shaft seal on both sides, add the suffix DV to the number (e.g., SAF2522DV).
- To order pillow block housings with DUSTAC shaft seal and one end closed, add the suffix DC to the number (e.g., SAF22522DC).
- Standard sizes of DUSTAC shaft seals are shown in the table. Other sizes are available upon request.

- On each shaft, there must be only one fixed bearing. If the bearing is to be fixed, the stabilizing ring can be inserted between the bearing outer ring and the housing shoulder on the locknut side of the bearing. All other bearings on this shaft should be centered in the housing.
- The upper half of the housing or cap should be thoroughly cleaned and checked for burrs. Place it over the bearing and seals. The dowel pins will align the cap to the base.
- After the cap bolts are tightened, it is most important to position the V-ring seal to its proper fitted width. This is accomplished by moving the seal until it is flush with the outside face of the cavity. This provides proper compression of the lip against the cartridge face.

INSTALLATION PROCEDURE

- Check shaft diameters to print specification. Remove any burrs or sharp edges. Be sure that the shaft surface is clean and dry beyond the area of seal location.
- Expand the V-ring seal over the shaft to the approximate inboard position (reference dimension B in the tables). *Make sure the lip of the seal faces the bearing.*
- Slide the seal cartridge onto the shaft until the V-ring fits into its cavity.
- Mount the bearing, sleeve, lockwasher and locknut in a normal manner and adjust for internal clearance.
- If both ends have seals, repeat steps 2 and 3 with the V-ring going on last with its lip facing the bearing.
- Thoroughly clean the housing base and remove any paint or burrs from the mating surfaces of the housing cap.
- Lower shaft, bearing and seals into the housing base, taking care to guide the seals into the seal grooves.

NOTE

Housing caps and bases are not interchangeable.

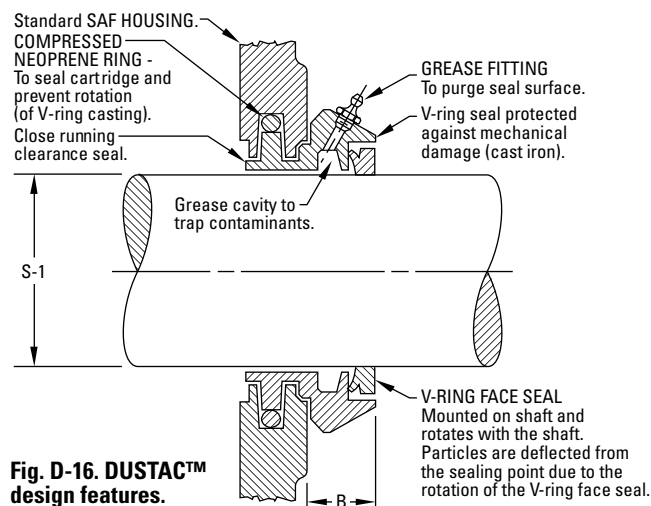

INCH SINE BAR GAGES

- Tapered-bore, antifriction bearings are mounted either on adapter sleeves or on tapered shaft seats.
- In cases where tapered bore bearings are mounted directly on the shaft, the shaft must conform to the tapered bore of the bearing to ensure a proper fit. If a proper fit is not achieved, the results could be:
 - Turning of the bearing inner race on the shaft.
 - Uneven loading of the bearing.
 - Severe inner race hoop stress.
 - Insufficient support (back-up) of the inner race on the shaft.
- All of these conditions could lead to premature bearing wear. Therefore, the manufacture, maintenance and measurement of accurate shaft tapers is important.
- There are two accepted ways of measuring tapered shafts: ring gages and sine bar gages.
- Precision measurement of tapered shafts is difficult with ring gages and may be impossible in the case of large shafts where gages are large, cumbersome and heavy.
- Sine bar gages provide an accurate and easy method of measurement.
- Lightweight, and easy to handle and use, sine bar gages achieve precise gaging of the shaft size and taper.
- A complete set for measurement of 1:12 shaft tapers consists of 3 in., 4 in., 5½ in., 7 in., 10 in. and 14 in. sine bar

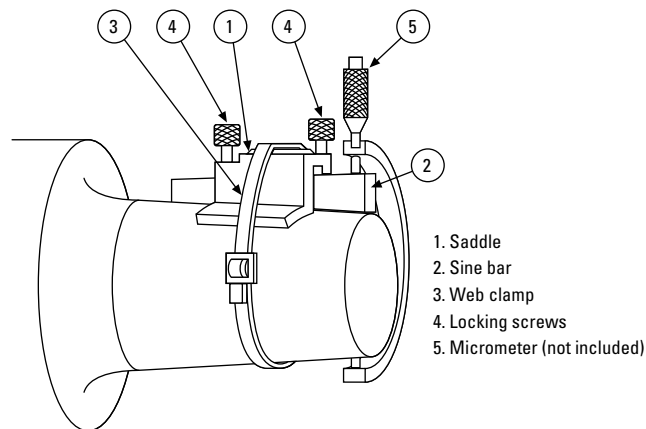

Fig. D-17. Parts of a sine gage.

gages, sine bar saddle no. T-5491-C, web clamp no. T-5489-A and a wooden box no. T-5224-C. A complete set for 1:30 shaft tapers consists of 4 in., 6 in., 8 in. and 12 in. sine bar gages.

- Sine bars can be purchased individually or in any combination of sizes to meet your individual needs. Use tables D-22 and D-23 to select appropriate sine bar part number.
- All sine bars require a sine bar saddle and web clamp. A wooden box is optional.
- For information on the use of sine bars, prices and delivery, consult your Timken engineer.

TABLE D-22.

Part No.	Size in.	For Bearings
T-3071-C	3.0000	22232K to 22240K
	3.0000	22322K to 22328K
	3.0000	23040K to 23048K
	3.0000	23130K to 23136K
	3.0000	23226K to 23230K
T-3072-C	4.0000	22248K to 22256K
	4.0000	22330K to 22340K
	4.0000	23052K to 23076K
	4.0000	23138K to 23148K
	4.0000	23232K to 23240K
T-3073-C	5.5000	22260K to 22264K
	5.5000	23080K to 230/500K
	5.5000	23152K to 23164K
	5.5000	23244K to 23256K
		239/600K to 239/710K

NOTE: All sine bars require a sine bar saddle, T-5491-C, and a web clamp, T-5489-A.

TABLE D-23.

Part No.	Size in.	For Bearings
T-3074-C	7.0000	230/530K to 230/750K
	7.0000	23168K to 23196K
	7.0000	23260K to 23276K
T-3075-C	10.0000	239/750K to 239/1120K
	10.0000	230/800K to 230/1180
	10.0000	231/500K to 231/710K
T-3076-C	14.0000	23280K to 232/530K
	14.0000	230/1250 and up
	14.0000	231/750K and up
T-5476-C	4.0000	232/560K and up
	4.0000	239/118K and up
T-5477-C	4.0000	24040K to 24056K
	6.0000	24132K to 24144K
T-5478-C	6.0000	24060K to 24084K
	8.0000	24148K to 24160K
T-5479-C	8.0000	24089K to 240/630K
	12.0000	24164K to 24192K
	12.0000	240/670K and up
	12.0000	24196K and up

NOTE: The table above represents the sine bar sizes developed for a full range of tapered bore bearings with a 1:12 and a 1:30 taper. Additional sizes are available to fit a variety of width-and-taper combinations. Consult your local Timken engineer for availability.





SAF SPHERICAL ROLLER BEARING INCH ACCESSORIES

Spherical roller bearing accessories are manufactured to the same quality standards as our bearings, ensuring a secure fit to straight and stepped shafts.

- **Sizes:** Standard accessories for use with SAF assemblies are available in inch shaft sizes up to 1000 mm (40 in.). Accessories for metric shaft sizes also are available upon request.
- **Features:** Extensive product range, including hydraulic assist, for integration into a full range of industrial applications.
- **Benefits:** Supports full range of installation and removal needs, minimizing the chance for damage to the bearing.

Nomenclature.....D-84
 Accessories Prefixes and Suffixes.....D-85
 Inch Accessories – Pull-Type Sleeves.....D-86
 Inch Accessories – Push-Type Sleeves.....D-96
 Inch Accessories – Locknuts and Lockwashers.....D-100
 Inch Accessories – Locknuts and Lockplates.....D-104
 Inch HMVC Hydraulic Nuts.....D-108

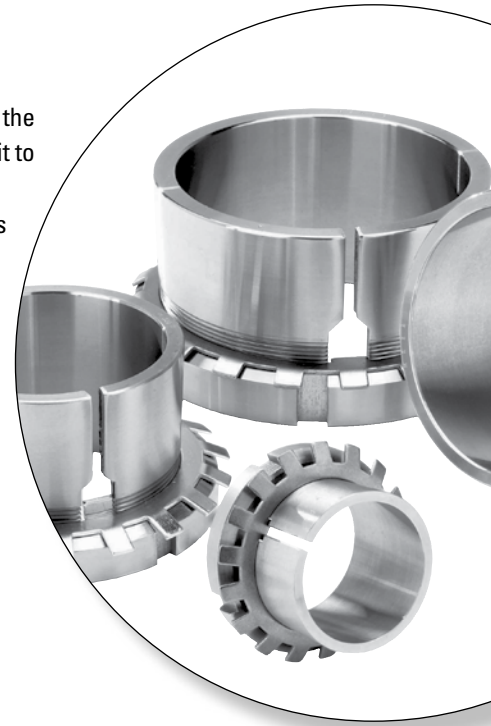

NOMENCLATURE

Timken provides accessories for your every need. To complement our line of Timken® spherical roller bearings, we offer bearing sleeves and locking devices in a wide range of sizes. These accessories are manufactured to the same quality standards as our bearings, ensuring a secure fit to straight and stepped shafts. Available in sizes up to 1000 mm (39.3701 in.), bearing sleeves are available in two distinct designs: assembled adapter sleeves and withdrawal sleeves.

ADAPTER SLEEVES

Timken adapter sleeves are used in conjunction with a nut and locking device to mount a tapered bore bearing onto a straight shaft using a pull-type fit. Smaller size assemblies (20 mm [0.78 in.] - 200 mm [12 in.] shaft) commonly use simple nuts, whereas larger assemblies (sizes >200 mm [12 in.]) may use HMV hydraulic nuts to assist in mounting. Table D-24 outlines our part number nomenclature, which is consistent with world standards for adapter sleeves.

TABLE D-24. INCH ADAPTER SLEEVES (SNW, SNP) FOR INCH SHAFT SIZES ARE SUPPLIED WITH CORRESPONDING LOCKNUT AND LOCKING DEVICE

Assembly	Sleeve	Locknut	Locking Device
SNW	S	N, AN	W
SNP	S	N	P

NOTE: SNW assembly consists of a sleeve, locknut and lockwasher.

NOTE: SNP assembly consists of a sleeve, locknut and lockplate.

NOTE: Metric accessories are available. Please reference the Timken Spherical Roller Bearing Catalog (order no. 10446).

WITHDRAWAL SLEEVES

Withdrawal sleeves feature a push-type mounting arrangement and a locking device (i.e., locknut or lockplate) to secure a bearing to a shaft. This design is not as widely used as the adapter sleeve assembly, and it does require the use of a specially designed dismantling nut. Timken’s part number nomenclature for withdrawal sleeves also conforms to industry-accepted standards. Nuts are not supplied with the withdrawal sleeve and must be ordered separately. The dismantling of large assemblies can be eased by using a hydraulic nut (HMV).

TABLE D-25. INCH WITHDRAWAL SLEEVE FOR INCH SHAFT SIZES

Sleeve	Locknut	Lockwasher/Plate	Dismounting Nut
SK	N, AN	W, P	AN, ARN, RN, N



LOCKING DEVICE

Timken offers a wide range of locknuts to locate bearing assemblies on application shafts. Sometimes referred to as shaft or withdrawal nuts, they are used to secure the assembly onto, and sometimes aid with the removal from the shaft.

LOCKWASHERS (W)

Locking washers are designed to secure the relative movement of a properly positioned locknut, so that a bearing and adapter sleeve remain tightly fitted to a shaft or a bearing remains secure against a shaft shoulder. The tab in the bore of the washer engages a keyway in the shaft or slot in the adapter sleeve. There are tabs on the O.D. of the washer that can be bent over into slots on the circumference of the locknut. Locking washers are used with locknuts with inch dimensions in the N and AN series.

LOCKPLATES (P)

Lockplates are bolted onto the outboard face of the locknut and fit into a keyway machined in the shaft or a slot in the adapter sleeve.

- P series are mounted on inch shafts sizes with N locknuts.

To learn more about our spherical roller bearing accessories, contact your Timken engineer. Standard suffixes and prefixes are found on page D-85.

INCH ACCESSORIES – PULL-TYPE SLEEVES

SNW/SNP – PULL-TYPE SLEEVE, LOCKNUT, LOCKWASHER/LOCKPLATE ASSEMBLIES

- The table below shows dimensions for adapter assemblies and components used in the mounting of tapered bore bearings on shafts.
- SNW assembly consists of a sleeve, locknut and lockwasher.
- SNP assembly consists of a sleeve, locknut and lockplate.

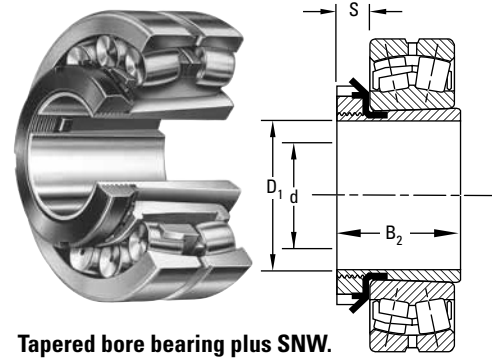

Tapered bore bearing plus SNW.

Bearing No. ⁽¹⁾	Accessory Numbers				Shaft Dimensions		Adapter Dimensions			SNW/SNP Assembly Wt. lbs.
	Assembly	Sleeve	Locknut	Lockwasher Lockplate	Diameter d	Tolerance ⁽²⁾	B ₂	S	D ₁	
					in.	in.	in.	in.	in.	
SERIES 222K										
22207K	SNW-07 x 1 3/16	S-07	N-07	W-07	1 3/16	-0.003	1 29/64	29/64	2 1/16	0.32
22208K	SNW-08 x 1 5/16	S-08	N-08	W-08	1 5/16	-0.003	1 21/32	29/64	2 1/4	0.42
	SNW-09 x 1 3/8	S-09 x 1 3/8			1 3/8					
22209K	SNW-09 x 1 7/16	S-09	N-09	W-09	1 7/16	-0.003	1 37/64	1/2	2 17/32	0.6
	SNW-09 x 1 1/2	S-09 x 1 1/2			1 1/2					
22210K	SNW-10 x 1 5/8	S-10 x 1 5/8			1 5/8		1 49/64	9/16	2 11/16	0.7
	SNW-10 x 1 11/16	S-10	N-10	W-10	1 11/16	-0.003				
22210K	SNW-10 x 1 3/4	S-10 x 1 3/4			1 3/4					
	SNW-11 x 1 7/8	S-11 x 1 7/8			1 7/8					
22211K	SNW-11 x 1 15/16	S-11	N-11	W-11	1 15/16	-0.003	1 27/32	9/16	2 31/32	0.8
	SNW-11 x 2	S-11 x 2			2					
22212K	SNW-12 x 2 1/16	S-12	N-12	W-12	2 1/16	-0.004	1 63/64	19/32	3 5/32	1.1
	SNW-13 x 2 1/8	S-13 x 2 1/8			2 1/8					
22213K	SNW-13 x 2 3/16	S-13	N-13	W-13	2 3/16	-0.004	2 3/32	5/8	3 3/8	1.4
	SNW-13 x 2 1/4	S-13 x 2 1/4			2 1/4					
22214K	SNW-14 x 2 5/16	S-14	N-14	W-14	2 5/16	-0.004	2 11/64	5/8	3 5/8	1.8
	SNW-15 x 2 3/8	S-15 x 2 3/8			2 3/8					
22215K	SNW-15 x 2 7/16	S-15	AN-15	W-15	2 7/16	-0.004	2 19/64	43/64	3 7/8	2.0
	SNW-15 x 2 1/2	S-15 x 2 1/2			2 1/2					
22216K	SNW-16 x 2 5/8	S-16 x 2 5/8			2 5/8					
	SNW-16 x 2 11/16	S-16	AN-16	W-16	2 11/16	-0.004	2 3/8	43/64	4 5/32	2.4
22216K	SNW-16 x 2 3/4	S-16 x 2 3/4			2 3/4					
	SNW-17 x 2 13/16	S-17 x 2 13/16			2 13/16					
22217K	SNW-17 x 2 7/8	S-17 x 2 7/8			2 7/8					
	SNW-17 x 2 15/16	S-17	AN-17	W-17	2 15/16	-0.004	2 31/64	45/64	4 13/32	3.0
22217K	SNW-17 x 3	S-17 x 3			3					
	SNW-18 x 3 1/16	S-18 x 3 1/16			3 1/16					
22218K	SNW-18 x 3 1/8	S-18 x 3 1/8			3 1/8					
	SNW-18 x 3 3/16	S-18	AN-18	W-18	3 3/16	-0.004	2 41/64	25/32	4 21/32	3.0
22218K	SNW-18 x 3 1/4	S-18 x 3 1/4			3 1/4					
	SNW-19 x 3 5/16	S-19 x 3 5/16			3 5/16					
22219K	SNW-19 x 3 5/16	S-19	AN-19	W-19	3 5/16	-0.004	2 49/64	13/16	4 15/16	3.3
	SNW-20 x 3 3/8	S-20 x 3 3/8			3 3/8					

⁽¹⁾Bold shaft sizes are standard. When ordering non-standard accessories, specify shaft size.

⁽²⁾Tolerance range is from +0 to value listed.

Continued on next page.

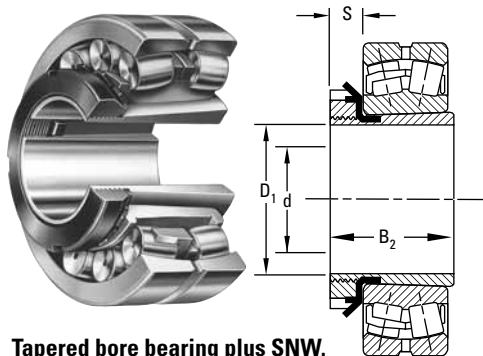

Tapered bore bearing plus SNW.

Continued from previous page.

Bearing No. ⁽¹⁾	Accessory Numbers				Shaft Dimensions		Adapter Dimensions			SNW/SNP Assembly Wt.
	Assembly	Sleeve	Locknut	Lockwasher Lockplate	Diameter d	Tolerance ⁽²⁾	B ₂	S	D ₁	
					in.	in.	in.	in.	in.	lbs.
22220K	SNW-20 x 3 7/16	S-20	AN-20	W-20	3 7/16	-0.004	2 7/8	27/32	5 3/16	4.4
	SNW-20 x 3 1/2	S-20 x 3 1/2			3 1/2					
22222K	SNW-22 x 3 13/16	S-22 x 3 13/16			3 13/16					
	SNW-22 x 3 7/8	S-22 x 3 7/8			3 7/8					
	SNW-22 x 3 15/16	S-22	AN-22	W-22	3 15/16	-0.004	3 13/64	29/32	5 23/32	5.0
	SNW-22 x 4	S-22 x 4			4					
22224K	SNW-24 x 4 1/16	S-22 x 4 1/16			4 1/16					
	SNW-24 x 4 1/8	S-22 x 4 1/8			4 1/8					
	SNW-24 x 4 3/16	S-24	AN-24	W-24	4 3/16	-0.005	3 15/32	15/16	6 1/8	6.7
	SNW-24 x 4 1/4	S-24 x 4 1/4			4 1/4					
22226K	SNW-26 x 4 5/16	S-26 x 4 5/16			4 5/16					
	SNW-26 x 4 3/8	S-26 x 4 3/8			4 3/8					
	SNW-26 x 4 7/16	S-26	AN-26	W-26	4 7/16	-0.005	3 49/64	1	6 3/4	8.6
	SNW-26 x 4 1/2	S-26 x 4 1/2			4 1/2					
22228K	SNW-28 x 4 13/16	S-28 x 4 13/16			4 13/16					
	SNW-28 x 4 7/8	S-28 x 4 7/8			4 7/8					
	SNW-28 x 4 15/16	S-28	AN-28	W-28	4 15/16	-0.005	3 63/64	1 1/16	7 3/32	10.3
	SNW-28 x 5	S-28 x 5			5					
22230K	SNW-30 x 5 1/8	S-30 x 5 1/8			5 1/8					
	SNW-30 x 5 3/16	S-30	AN-30	W-30	5 3/16	-0.005	4 15/64	1 1/8	7 11/16	13.5
	SNW-30 x 5 1/4	S-30 x 5 1/4			5 1/4					
22232K	SNW-32 x 5 3/8	S-30 x 5 3/8			5 3/8					
	SNW-32 x 5 7/16	S-32	AN-32	W-32	5 7/16	-0.005	4 37/64	1 3/16	8 1/16	15.6
	SNW-32 x 5 1/2	S-32 x 5 1/2			5 1/2					
22234K	SNW-34 x 5 13/16	S-34 x 5 13/16			5 13/16					
	SNW-34 x 5 7/8	S-34 x 5 7/8			5 7/8					
	SNW-34 x 5 15/16	S-34	AN-34	W-34	5 15/16	-0.005	4 27/32	1 7/32	8 21/32	19.4
	SNW-34 x 6	S-34 x 6			6					
22236K	SNW-36 x 6 15/16	S-36 x 6 15/16			6 15/16					
	SNW-36 x 6 3/8	S-36 x 6 3/8			6 3/8					
	SNW-36 x 6 7/16	S-36	AN-36	W-36	6 7/16	-0.005	5 1/32	1 1/4	9 1/16	20.5
	SNW-36 x 6 1/2	S-36 x 6 1/2			6 1/2					

⁽¹⁾ Bold shaft sizes are standard. When ordering non-standard accessories, specify shaft size.

⁽²⁾ Tolerance range is from +0 to value listed.

Continued on next page.

INCH ACCESSORIES – PULL-TYPE SLEEVES – continued
SNW/SNP – PULL-TYPE SLEEVE, LOCKNUT, LOCKWASHER/LOCKPLATE ASSEMBLIES

- The table below shows dimensions for adapter assemblies and components used in the mounting of tapered bore bearings on shafts.
- SNW assembly consists of a sleeve, locknut and lockwasher.
- SNP assembly consists of a sleeve, locknut and lockplate.

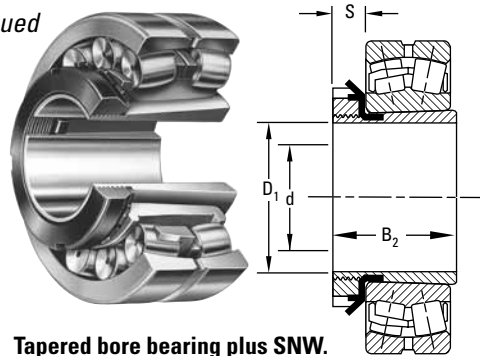

Tapered bore bearing plus SNW.

Continued from previous page.

Bearing No. ⁽¹⁾	Accessory Numbers				Shaft Dimensions		Adapter Dimensions			SNW/SNP Assembly Wt.
	Assembly	Sleeve	Locknut	Lockwasher Lockplate	Diameter d	Tolerance ⁽²⁾	B ₂	S	D ₁	
					in.	in.	in.	in.	in.	lbs.
22238K	SNW-38 x 6 13/16	S-38 x 6 13/16			6 13/16					
	SNW-38 x 6 7/8	S-38 x 6 7/8			6 7/8					
	SNW-38 x 6 15/16	S-38	AN-38	W-38	6 15/16	-0.005	5 17/64	1 9/32	9 15/32	23.4
	SNW-38 x 7	S-38 x 7			7					
22240K	SNW-40 x 7 1/8	S-40 x 7 1/8			7 1/8					
	SNW-40 x 7 3/16	S-40	AN-40	W-40	7 3/16	-0.005	5 31/64	1 11/32	9 27/32	30.5
	SNW-40 x 7 1/4	S-40 x 7 1/4			7 1/4					
22244K	SNW-44 x 7 13/16	S-44 x 7 13/16			7 13/16					
	SNW-44 x 7 7/8	S-44 x 7 7/8			7 7/8					
	SNW-44 x 7 15/16	S-44	N-044	W-44	7 15/16	-0.005	5 29/32	1 3/8	11	33.0
22248K	SNW-44 x 8	S-44 x 8			8					
	SNP-48 x 8 7/16	S-48	N-048	P-48	8 7/16	-0.006	6 5/8	1 23/64	11 7/16	37.5
22252K	SNP-48 x 8 15/16	S-48 x 8 15/16			8 15/16					
	SNP-52 x 9 7/16	S-52	N-052	P-52	9 7/16	-0.006	7 37/64	1 27/64	12 3/16	44.0
SERIES 230K										
23024K	SNW-3024 x 4 1/16	S-3024 x 4 1/16			4 1/16					
	SNW-3024 x 4 1/8	S-3024 x 4 1/8			4 1/8					
	SNW-3024 x 4 3/16	S-3024	N-024	W-024	4 3/16	-0.005	2 61/64	13/16	5 11/16	6.1
	SNW-3024 x 4 1/4	S-3024 x 4 1/4			4 1/4					
23026K	SNW-3026 x 4 5/16	S-3024 x 4 5/16			4 5/16					
	SNW-3026 x 4 3/8	S-3024 x 4 3/8			4 3/8					
	SNW-3026 x 4 7/16	S-3026	N-026	W-026	4 7/16	-0.005	3 15/64	7/8	6 1/8	7.5
SNW-3026 x 4 1/2	S-3026 x 4 1/2			4 1/2						
	23028K	SNW-3028 x 4 13/16	S-3028 x 4 13/16		4 13/16					
SNW-3028 x 4 7/8		S-3028 x 4 7/8		4 7/8						
SNW-3028 x 4 15/16		S-3028	N-028	W-028	4 15/16	-0.005	3 11/32	15/16	6 1/2	8.4
23030K	SNW-3030 x 5 1/8	S-3030 x 5 1/8			5 1/8					
	SNW-3030 x 5 3/16	S-3030	N-030	W-030	5 3/16	-0.005	3 31/64	31/32	7 1/8	9.8
	SNW-3030 x 5 1/4	S-3030 x 5 1/4			5 1/4					
23032K	SNW-3032 x 5 3/8	S-3032 x 5 3/8			5 3/8					
	SNW-3032 x 5 7/16	S-3032	N-032	W-032	5 7/16	-0.005	3 23/32	1 1/32	7 1/2	11.8
SNW-3032 x 5 1/2	S-3032 x 5 1/2			5 1/2						

⁽¹⁾Bold shaft sizes are standard. When ordering non-standard accessories, specify shaft size.

⁽²⁾Tolerance range is from +0 to value listed.

Continued on next page.

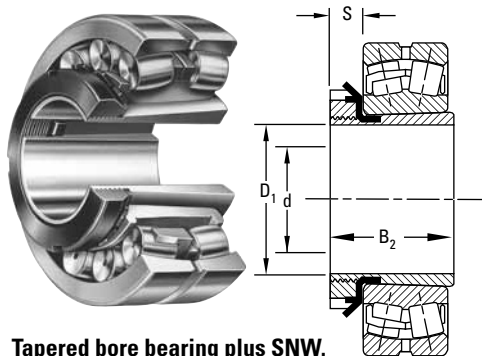

Tapered bore bearing plus SNW.

Continued from previous page.

Bearing No. ⁽¹⁾	Accessory Numbers				Shaft Dimensions		Adapter Dimensions			SNW/SNP Assembly Wt. lbs.
	Assembly	Sleeve	Locknut	Lockwasher Lockplate	Diameter d	Tolerance ⁽²⁾	B ₂	S	D ₁	
					in.	in.	in.	in.	in.	
23034K	SNW-3034 x 5 13/16	S-3034 x 5 13/16			5 13/16					
	SNW-3034 x 5 7/8	S-3034 x 5 7/8			5 7/8					
	SNW-3034 x 5 15/16	S-3034	N-034	W-034	5 15/16	-0.005	4 1/64	1 1/16	7 7/8	13.3
	SNW-3034 x 6	S-3034 x 6			6					
23036K	SNW-3036 x 6 5/16	S-3036 x 6 5/16			6 5/16					
	SNW-3036 x 6 3/8	S-3036 x 6 3/8			6 3/8					
	SNW-3036 x 6 7/16	S-3036	N-036	W-036	6 7/16	-0.005	4 11/32	1 3/32	8 1/4	15.2
	SNW-3036 x 6 1/2	S-3036 x 6 1/2			6 1/2					
23038K	SNW-3038 x 6 13/16	S-3038 x 6 13/16			6 13/16					
	SNW-3038 x 6 7/8	S-3038 x 6 7/8			6 7/8					
	SNW-3038 x 6 15/16	S-3038	N-038	W-038	6 15/16	-0.005	4 13/32	1 1/8	8 11/16	16.7
	SNW-3038 x 7	S-3038 x 7			7					
23040K	SNW-3040 x 7 1/8	S-3040 x 7 1/8			7 1/8					
	SNW-3040 x 7 3/16	S-3040	N-040	W-040	7 3/16	-0.005	4 3/4	1 3/16	9 7/16	19.7
	SNW-3040 x 7 1/4	S-3040 x 7 1/4			7 1/4					
23044K	SNW-3044 x 7 13/16	S-3044 x 7 13/16			7 13/16					
	SNW-3044 x 7 7/8	S-3044 x 7 7/8			7 7/8					
	SNW-3044 x 7 15/16	S-3044	N-044	W-044	7 15/16	-0.005	5 1/8	1 1/4	10 1/4	24.4
	SNW-3044 x 8	S-3044 x 8			8					
23048K	SNP-3048 x 8 7/16	S-3048 x 8 7/16			8 7/16					
	SNP-3048 x 8 1/2	S-3048 x 8 1/2			8 1/2					
	SNP-3048 x 8 15/16	S-3048	N-048	P-48	8 15/16	-0.006	5 7/16	1 11/32	11 7/16	32.2
	SNP-3048 x 9	S-3048 x 9			9					
23052K	SNP-3052 x 9 7/16	S-3052	N-052	P-52	9 7/16	-0.006	6 1/64	1 13/32	12 3/16	41.1
	SNP-3052 x 9 1/2	S-3052 x 9 1/2			9 1/2					
23056K	SNP-3056 x 9 15/16	S-3056 x 9 15/16			9 15/16					
	SNP-3056 x 10	S-3056 x 10			10					
	SNP-3056 x 10 7/16	S-3056	N-056	P-56	10 7/16	-0.007	6 3/16	1 1/2	13	45.4
	SNP-3056 x 10 1/2	S-3056 x 10 1/2			10 1/2					
23060K	SNP-3060 x 10 15/16	S-3060	N-060	P-60	10 15/16	-0.007	6 47/64	1 9/16	14 3/16	58.9
	SNP-3060 x 11	S-3060 x 11			11					
23064K	SNP-3064 x 11 7/16	S-3060 x 11 7/16			11 7/16					
	SNP-3064 x 11 1/2	S-3060 x 11 1/2			11 1/2					
	SNP-3064 x 11 15/16	S-3064	N-064	P-64	11 15/16	-0.007	6 61/64	1 21/32	15	65.7
	SNP-3064 x 12	S-3064 x 12			12					

⁽¹⁾ Bold shaft sizes are standard. When ordering non-standard accessories, specify shaft size.

⁽²⁾ Tolerance range is from +0 to value listed.

Continued on next page.

INCH ACCESSORIES – PULL-TYPE SLEEVES – continued
SNW/SNP – PULL-TYPE SLEEVE, LOCKNUT, LOCKWASHER/LOCKPLATE ASSEMBLIES

- The table below shows dimensions for adapter assemblies and components used in the mounting of tapered bore bearings on shafts.
- SNW assembly consists of a sleeve, locknut and lockwasher.
- SNP assembly consists of a sleeve, locknut and lockplate.

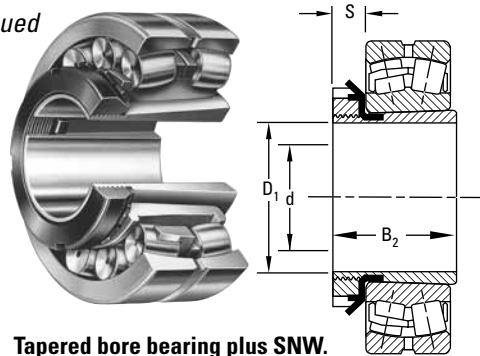

Tapered bore bearing plus SNW.

Continued from previous page.

Bearing No. ⁽¹⁾	Accessory Numbers				Shaft Dimensions		Adapter Dimensions			SNW/SNP Assembly Wt.
	Assembly	Sleeve	Locknut	Lockwasher Lockplate	Diameter d	Tolerance ⁽²⁾	B ₂	S	D ₁	
					in.	in.	in.	in.	in.	lbs.
23068K	SNP-3068 X 12 7/16	S-3068	N-068	P-68	12 7/16	-0.008	7 39/64	1 25/32	15 3/4	77.8
	SNP-3068 X 12 1/2	S-3068 x 12 1/2			12 1/2					
	SNP-3072 X 12 15/16	S-3072 x 12 15/16			12 15/16					
	SNP-3072 X 13	S-3072 x 13			13					
23072K	SNP-3072 X 13 7/16	S-3072	N-072	P-72	13 7/16	-0.008	7 37/64	1 25/32	16 1/2	86.2
	SNP-3072 X 13 1/2	S-3072 x 13 1/2			13 1/2					
23076K	SNP-3076 X 13 15/16	S-3076	N-076	P-76	13 15/16	-0.008	7 3/4	1 57/64	17 3/4	94.3
	SNP-3076 X 14	S-3076 x 14			14					
23080K	SNP-3080 x 15	S-3080	N-080	P-80	15	-0.008	8 13/32	2 1/16	18 1/2	100.0
23084K	SNP-3084 x 15 3/4	S-3084	N-084	P-84	15 3/4	-0.008	8 31/64	2 1/16	19 5/16	110.0
23088K	SNP-3088 x 16 1/2	S-3088	N-088	P-88	16 1/2	-0.008	9 7/64	2 3/8	20 1/2	144.0
23092K	SNP-3092 x 17	S-3092	N-092	P-92	17	-0.008	9 11/32	2 3/8	21 1/4	153.0
23096K	SNP-3096 x 18	S-3096	N-096	P-96	18	-0.008	9 29/64	2 3/8	22 1/16	162.0
230/500K	SNP-30/500 x 18 1/2	S-30/500	N-500	P-500	18 1/2	-0.008	9 27/32	2 45/64	22 13/16	180.0
230/530K	SNP-30/530 x 19 1/2	S-30/530	N-530	P-530	19 1/2	-0.008	10 37/64	2 45/64	24 13/16	221.0
230/560K	SNP-30/560 x 20 15/16	S-30/560	N-560	P-560	20 15/16	-0.008	11 7/32	2 61/64	25 9/16	243.0
230/600K	SNP-30/600 x 21 15/16	S-30/600	N-600	P-600	21 15/16	-0.008	11 29/64	2 61/64	27 9/16	322.0
230/630K	SNP-30/630 x 23 15/16	S-30/630	N-630	P-630	23 15/16	-0.008	11 59/64	2 61/64	28 3/4	350.0
230/670K	SNP-30/670 x 24 15/16	S-30/670	N-670	P-670	24 15/16	-0.008	12 27/32	3 9/64	30 11/16	421.0
230/710K	SNP-30/710 x 26 7/16	S-30/710	N-710	P-710	26 7/16	-0.008	13 1/2	3 37/64	32 11/16	492.0
230/750K	SNP-30/750 x 27 15/16	S-30/750	N-750	P-750	27 15/16	-0.008	14 3/32	3 37/64	34 1/4	536.0
230/800K	SNP-30/800 x 29 7/16	S-30/800	N-800	P-800	29 7/16	-0.008	14 13/32	3 37/64	36 1/4	662.0
230/850K	SNP-30/850 x 31 7/16	S-30/850	N-850	P-850	31 7/16	-0.008	15	3 37/64	38 9/16	747.0
230/900K	SNP-30/900 x 33 7/16	S-30/900	N-900	P-900	33 7/16	-0.008	15 11/16	3 61/64	40 9/16	853.0
230/950K	SNP-30/950 x 34 7/16	S-30/950	N-950	P-950	35 7/16	-0.008	16 1/2	3 61/64	43	935.0

⁽¹⁾ Bold shaft sizes are standard. When ordering non-standard accessories, specify shaft size.

⁽²⁾ Tolerance range is from +0 to value listed.

Continued on next page.

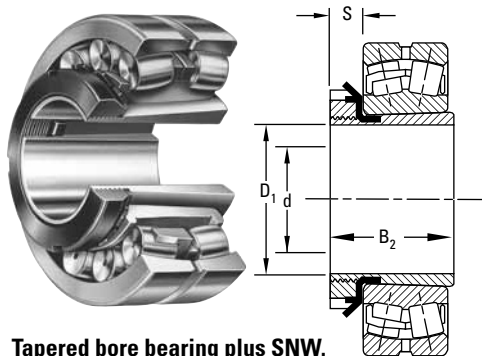

Tapered bore bearing plus SNW.

Continued from previous page.

Bearing No. ⁽¹⁾	Accessory Numbers				Shaft Dimensions		Adapter Dimensions			SNW/SNP Assembly Wt. lbs.
	Assembly	Sleeve	Locknut	Lockwasher Lockplate	Diameter d	Tolerance ⁽²⁾	B ₂	S	D ₁	
SERIES 223K AND 232K										
22308K	SNW-108 x 1 5/16	S-108	N-08	W-08	1 5/16	-0.003	2 1/64	1/2	2 1/4	0.8
22309K	SNW-109 x 1 7/16	S-109	N-09	W-09	1 7/16	-0.003	2 9/64	1/2	2 17/32	0.8
22310K	SNW-110 x 1 11/16	S-110	N-10	W-10	1 11/16	-0.003	2 25/64	9/16	2 11/16	0.9
22311K	SNW-111 x 1 15/16	S-111	N-11	W-11	1 15/16	-0.003	2 33/64	9/16	2 31/32	0.9
22312K	SNW-112 x 2 1/16	S-112	N-12	W-12	2 1/16	-0.004	2 21/32	19/32	3 5/32	1.2
22313K	SNW-113 x 2 3/16	S-113	N-13	W-13	2 3/16	-0.004	2 49/64	5/8	3 3/8	1.7
22314K	SNW-114 x 2 5/16	S-114	N-14	W-14	2 5/16	-0.004	2 61/64	5/8	3 5/8	2.3
	SNW-115 x 2 3/8	S-115 x 2 3/8			2 3/8					
22315K	SNW-115 x 2 7/16	S-115	AN-15	W-15	2 7/16	-0.004	3 5/64	43/64	3 7/8	3.0
	SNW-115 x 2 1/2	S-115 x 2 1/2			2 1/2					
	SNW-116 x 2 5/8	S-116 x 2 5/8			2 5/8					
22316K	SNW-116 x 2 11/16	S-116	AN-16	W-16	2 11/16	-0.004	3 13/64	43/64	4 5/32	3.2
	SNW-116 x 2 3/4	S-116 x 3/4			2 3/4					
	SNW-117 x 2 13/16	S-117 x 2 13/16			2 13/16					
	SNW-117 x 2 7/8	S-117 x 2 7/8			2 7/8					
22317K	SNW-117 x 2 15/16	S-117	AN-17	W-17	2 15/16	-0.004	3 5/16	45/64	4 13/32	3.5
	SNW-117 x 3	S-117 x 3			3					
	SNW-118 x 3 1/16	S-118 x 3 1/16			3 1/16					
	SNW-118 x 3 1/8	S-118 x 3 1/8			3 1/8					
22318K	SNW-118 x 3 3/16	S-118	AN-18	W-18	3 3/16	-0.004	3 35/64	25/32	4 21/32	4.0
	SNW-118 x 3 1/4	S-118 x 3 1/4			3 1/4					
22319K	SNW-119 x 3 5/16	S-119	AN-19	W-19	3 5/16	-0.004	3 45/64	13/16	4 15/16	5.0
	SNW-120 x 3 5/16	S-120 x 3 5/16			3 5/16					
	SNW-120 x 3 3/8	S-120 x 3 3/8			3 3/8					
22320K 23220K	SNW-120 x 3 7/16	S-120	AN-20	W-20	3 7/16	-0.004	3 31/32	27/32	5 3/16	6.2
	SNW-120 x 3 1/2	S-120 x 3 1/2			3 1/2					
	SNW-122 x 3 13/16	S-122 x 3 13/16			3 13/16					
	SNW-122 x 3 3/8	S-122 x 3 3/8			3 3/8					
22322K 23222K	SNW-122 x 3 15/16	S-122	AN-22	W-22	3 15/16	-0.004	4 11/32	29/32	5 23/32	6.5
	SNW-122 x 4	S-122 x 4			4					

⁽¹⁾Bold shaft sizes are standard. When ordering non-standard accessories, specify shaft size.

⁽²⁾Tolerance range is from +0 to value listed.

Continued on next page.

INCH ACCESSORIES – PULL-TYPE SLEEVES – continued
SNW/SNP – PULL-TYPE SLEEVE, LOCKNUT, LOCKWASHER/LOCKPLATE ASSEMBLIES

- The table below shows dimensions for adapter assemblies and components used in the mounting of tapered bore bearings on shafts.
- SNW assembly consists of a sleeve, locknut and lockwasher.
- SNP assembly consists of a sleeve, locknut and lockplate.

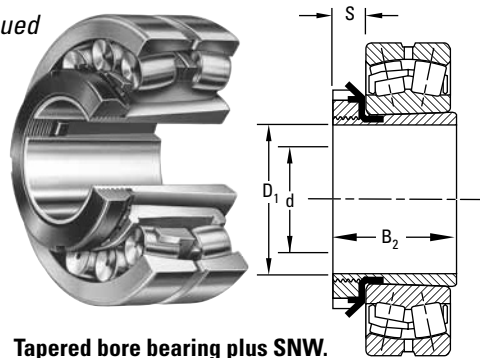

Tapered bore bearing plus SNW.

Continued from previous page.

Bearing No. ⁽¹⁾	Accessory Numbers				Shaft Dimensions		Adapter Dimensions			SNW/SNP Assembly Wt.
	Assembly	Sleeve	Locknut	Lockwasher Lockplate	Diameter d	Tolerance ⁽²⁾	B ₂	S	D ₁	
					in.	in.	in.	in.	in.	lbs.
22324K 23224K	SNW-124 x 4 1/16	S-124 x 4 1/16			4 1/16					
	SNW-124 x 4 1/8	S-124 x 4 1/8			4 1/8					
	SNW-124 x 4 3/16	S-124	AN-24	W-24	4 3/16	-0.005	4 41/64	15/16	6 1/8	8.0
	SNW-124 x 4 1/4	S-124 x 4 1/4			4 1/4					
22326K 23226K	SNW-126 x 4 3/16	S-126 x 4 3/16			4 3/16					
	SNW-126 x 4 3/8	S-126 4 3/8			4 3/8					
	SNW-126 x 4 7/16	S-126	AN-26	W-26	4 7/16	-0.005	4 63/64	1	6 3/4	12.4
	SNW-126 x 4 1/2	S-126 x 4 1/2			4 1/2					
22328K 23228K	SNW-126 x 4 9/16	S-126 x 4 9/16			4 9/16					
	SNW-128 x 4 13/16	S-128 x 4 13/16			4 13/16					
	SNW-128 x 4 7/8	S-128 x 4 7/8			4 7/8					
	SNW-128 x 4 15/16	S-128	AN-28	W-28	4 15/16	-0.005	5 21/64	1 1/16	7 3/32	13.0
22330K 23230K	SNW-128 x 5	S-128 x 5			5					
	SNW-130 x 5 1/8	S-130 x 5 1/8			5 1/8					
	SNW-130 x 5 3/16	S-130	AN-30	W-30	5 3/16	-0.005	5 5/8	1 1/8	7 11/16	17.6
	SNW-130 x 5 1/4	S-130 x 5 1/4			5 1/4					
22332K 23232K	SNW-130 x 5 5/16	S-130 x 5 5/16			5 5/16					
	SNW-130 x 5 3/8	S-130 x 5 3/8			5 3/8					
	SNW-132 x 5 7/16	S-132	AN-32	W-32	5 7/16	-0.005	5 59/64	1 3/16	8 1/16	18.5
	SNW-132 x 5 1/2	S-132 x 5 1/2			5 1/2					
22334K 23234K	SNW-132 x 5 3/4	S-132 x 5 3/4			5 3/4					
	SNW-134 x 5 13/16	S-134 x 5 13/16			5 13/16					
	SNW-134 x 5 7/8	S-134 x 5 7/8			5 7/8					
	SNW-134 x 5 15/16	S-134	AN-34	W-34	5 15/16	-0.005	6 3/16	1 7/32	8 21/32	21.0
22336K 23236K	SNW-134 x 6	S-134 x 6			6					
	SNW-136 x 6 7/16	S-136	AN-36	W-36	6 7/16	-0.005	6 29/64	1 1/4	9 1/16	22.5
	SNW-136 x 6 1/2	S-136 x 6 1/2			6 1/2					
	SNW-138 x 6 5/8	S-138 x 6 5/8			6 5/8					
22338K 23238K	SNW-138 x 6 3/4	S-138 x 6 3/4			6 3/4					
	SNW-138 x 6 15/16	S-138	AN-38	W-38	6 15/16	-0.005	6 3/4	1 9/32	9 15/32	28.0
	SNW-138 x 7	S-138 x 7			7					
	SNW-140 x 7 1/8	S-140 x 7 1/8			7 1/8					
22340K 23240K	SNW-140 x 7 3/16	S-140	AN-40	W-40	7 3/16	-0.005	7 3/32	1 11/32	9 27/32	36.0
	SNW-140 x 7 1/4	S-140 x 7 1/4			7 1/4					

⁽¹⁾Bold shaft sizes are standard. When ordering non-standard accessories, specify shaft size.

⁽²⁾Tolerance range is from +0 to value listed.

Continued on next page.

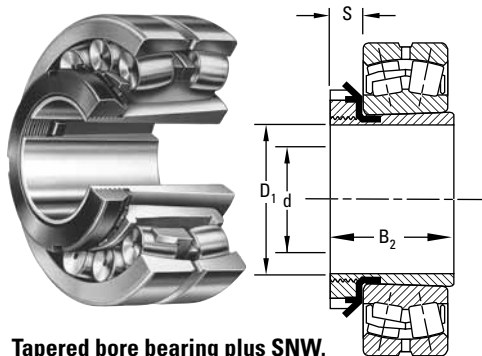

Tapered bore bearing plus SNW.

Continued from previous page.

Bearing No. ⁽¹⁾	Accessory Numbers					Shaft Dimensions		Adapter Dimensions			SNW/SNP Assembly Wt. lbs.
	Assembly	Sleeve	Locknut	Lockwasher Lockplate	Diameter d	Tolerance ⁽²⁾	B ₂	S	D ₁		
					in.	in.	in.	in.	in.		
22344K 23244K	SNW-144 x 7 ¹⁵/₁₆	S-144	N-044	W-44	7 ¹⁵/₁₆	-0.005	7 ⁹/₃₂	1 ³/₈	11	47.0	
22348K 23248K	SNP-148 x 8 ¹⁵/₁₆	S-148	N-048	P-48	8 ¹⁵/₁₆	-0.006	8 ⁷/₆₄	1 ¹¹/₃₂	11 ⁷/₁₆	38.3	
	SNP-148 x 9	S-148 x 9			9						
22352K 23252K	SNP-152 x 9 ⁷/₁₆	S-152	N-052	P-52	9 ⁷/₁₆	-0.006	8 ⁴⁹/₆₄	1 ¹³/₃₂	12 ¹³/₁₆	53.4	
	SNP-152 x 9 1/2	S-152 x 9 1/2			9 1/2						
22356K 23256K	SNP-3256 x 10 ⁷/₁₆	S-3256	N-056	P-56	10 ⁷/₁₆	-0.007	8 ¹⁵/₁₆	1 1/2	13	61.3	
	SNP-3256 x 10 1/2	S-3256 x 10 1/2			10 1/2	-0.007					
23260K	SNP-3260 x 10 ¹⁵/₁₆	S-3260	N-060	P-60	10 ¹⁵/₁₆	-0.007	9 ⁵/₈	1 ⁹/₁₆	14 ³/₃₂	68.5	
	SNP-3260 x 11	S-3260 x 11			11	-0.007					
23264K	SNP-3264 x 11 ¹⁵/₁₆	S-3264	N-064	P-64	11 ¹⁵/₁₆	-0.007	10 ²³/₆₄	1 ²¹/₃₂	15	98.0	
	SNP-3264 x 12	S-3264 x 12			12	-0.007					
	SNP-3268 x 12 1/2	S-3268 x 12 1/2			12 1/2	-0.007					
23268K	SNP-3268 x 12 ⁷/₈	S-3268	N-068	P-68	12 ⁷/₈	-0.007	11 ¹/₈	1 ²⁵/₃₂	15 ³/₄	105.0	
23272K	SNP-3272 x 13 ⁷/₁₆	S-3272	N-072	P-72	13 ⁷/₁₆	-0.007	11 ²⁷/₆₄	1 ²⁵/₃₂	16 ¹/₂	135.0	
	SNP-3272 x 13 1/2	S-3272 x 13 1/2			13 1/2	-0.007					
23276K	SNP-3276 x 13 ¹⁵/₁₆	S-3276	N-076	P-76	13 ¹⁵/₁₆	-0.007	11 ⁷/₈	1 ²⁹/₃₂	17 ³/₄	145.0	
	SNP-3276 x 14	S-3276 x 14			14	-0.007					
23280K	SNP-3280 x 15	S-3280	N-080	P-80	15	-0.007	12 ²¹/₃₂	2 ¹/₁₆	18 ¹/₂	165.0	
23284K	SNP-3284 x 15 ³/₄	S-3284	N-084	P-84	15 ³/₄	-0.007	13 ¹⁹/₆₄	2 ¹/₁₆	19 ⁵/₁₆	170.0	
23288K	SNP-3288 x 16 ¹/₂	S-3288	N-088	P-88	16 ¹/₂	-0.007	13 ⁶¹/₆₄	2 ³/₈	20 ¹/₂	260.0	
23292K	SNP-3292 x 16 ¹⁵/₁₆	S-3292	N-092	P-92	16 ¹⁵/₁₆	-0.007	18 ¹/₁₆	2 ³/₈	21 ¹/₄	291.0	
23296K	SNP-3296 x 17 ¹⁵/₁₆	S-3296	N-096	P-96	17 ¹⁵/₁₆	-0.007	15 ⁵/₃₂	2 ³/₈	22 ¹/₁₆	335.0	
232500K	SNP-32/500 x 18 ⁷/₁₆	S-32/500	N-500	P-500	18 ⁷/₁₆	-0.007	16 ¹/₂	2 ⁴⁵/₆₄	22 ¹³/₁₆	366.0	
232530K	SNP-32/530 x 18 ¹⁵/₁₆	S-32/530 x 18 ¹⁵/₁₆	N-530	P-530	18 ¹⁵/₁₆	-0.007	17 ¹⁷/₆₄	2 ⁴⁵/₆₄	24 ¹³/₁₆	421.0	
	SNP-32/530 x 19 1/16	S-32/530 x 19 1/16			19 1/16	-0.007					
232560K	SNP-32/560 x 20 ¹⁵/₁₆	S-32/560	N-560	P-560	20 ¹⁵/₁₆	-0.007	17 ⁵⁹/₆₄	2 ⁶¹/₆₄	25 ⁹/₁₆	478.0	
232600K	SNP-32/600 x 21 ¹⁵/₁₆	S-32/600	N-600	P-600	21 ¹⁵/₁₆	-0.007	18 ⁵⁵/₆₄	2 ⁶¹/₆₄	27 ⁹/₁₆	613.0	
232630K	SNP-32/630 x 23 ¹⁵/₁₆	S-32/630	N-630	P-630	23 ¹⁵/₁₆	-0.007	19 ⁵¹/₆₄	2 ⁶¹/₆₄	28 ³/₄	657.0	
232670K	SNP-32/670 x 24 ¹⁵/₁₆	S-32/670	N-670	P-670	24 ¹⁵/₁₆	-0.007	21 ¹/₃₂	3 ⁹/₆₄	30 ¹¹/₁₆	891.0	
232710K	SNP-32/710 x 26 ⁷/₁₆	S-32/710	N-710	P-710	26 ⁷/₁₆	-0.007	21 ¹⁵/₁₆	3 ³⁷/₆₄	32 ¹¹/₁₆	979.0	
232750K	SNP-32/750 x 27 ¹⁵/₁₆	S-32/750	N-750	P-750	27 ¹⁵/₁₆	-0.007	22 ⁶³/₆₄	3 ³⁷/₆₄	34 ¹/₄	1118.0	

⁽¹⁾Bold shaft sizes are standard. When ordering non-standard accessories, specify shaft size.

⁽²⁾Tolerance range is from +0 to value listed.

Continued on next page.

INCH ACCESSORIES – PULL-TYPE SLEEVES – continued

SNW/SNP – PULL-TYPE SLEEVE, LOCKNUT, LOCKWASHER/LOCKPLATE ASSEMBLIES

- The table below shows dimensions for adapter assemblies and components used in the mounting of tapered bore bearings on shafts.
- SNW assembly consists of a sleeve, locknut and lockwasher.
- SNP assembly consists of a sleeve, locknut and lockplate.

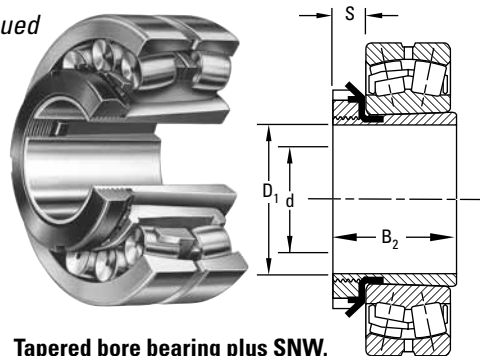

Tapered bore bearing plus SNW.

Continued from previous page.

Bearing No. ⁽¹⁾	Accessory Numbers				Shaft Dimensions		Adapter Dimensions			SNW/SNP Assembly Wt.
	Assembly	Sleeve	Locknut	Lockwasher Lockplate	Diameter d	Tolerance ⁽²⁾	B ₂	S	D ₁	
					in.	in.	in.	in.	in.	lbs.
SERIES 231K										
23122K	SNW-3122 x 3 15/16	S-22	N-022	W-022	3 15/16	-0.004	3 13/64	25/32	5 5/32	4.2
23124K	SNW-3124 x 4 3/16	S-24	N-024	W-024	4 3/16	-0.005	3 15/32	13/16	5 11/16	5.8
23126K	SNW-3126 x 4 7/16	S-26	N-026	W-026	4 7/16	-0.005	3 49/64	7/8	6 1/8	8.3
23128K	SNW-3128 x 4 15/16	S-28	N-028	W-028	4 15/16	-0.005	3 63/64	15/16	6 1/2	8.8
23130K	SNW-3130 x 5 3/16	S-30	N-030	W-030	5 3/16	-0.005	4 15/64	31/32	7 1/8	13.7
23132K	SNW-3132 x 5 7/16	S-32	N-032	W-032	5 7/16	-0.005	4 37/64	1 1/32	7 1/2	13.3
23134K	SNW-3134 x 5 15/16	S-34	N-034	W-034	5 15/16	-0.005	4 27/32	1 1/16	7 7/8	16.1
23136K	SNW-3136 x 6 7/16	S-36	N-036	W-036	6 7/16	-0.005	5 1/32	1 3/32	8 1/4	17.1
23138K	SNW-3138 x 6 15/16	S-38	N-038	W-038	6 15/16	-0.005	5 17/64	1 1/8	8 11/16	19.7
23140K	SNW-3140 x 7 3/16	S-40	N-040	W-040	7 3/16	-0.005	5 31/64	1 3/16	9 7/16	28.4
23144K	SNW-3144 x 7 15/16	S-44	N-044	W-044	7 15/16	-0.005	5 29/32	1 1/4	10 1/4	28.1
23148K	SNW-3144 x 8 15/16	S-48	N-048	P-48	8 15/16	-0.006	6 41/64	1 11/32	11 7/16	36.0
23152K	SNP-3152 x 9 7/16	S-52	N-052	P-52	9 7/16	-0.006	7 19/32	1 13/32	12 3/16	39.0
	SNP-3152 x 9 1/2	S-52 x 9 1/2			9 1/2					
	SNP-3156 x 9 15/16	S-3156 x 9 15/16			9 15/16					
	SNP-3156 x 10	S-3156 x 10			10					
23156K	SNP-3156 x 10 7/16	S-3156	N-056	P-56	10 7/16	-0.007	7 49/64	1 1/2	13	60.0
	SNP-3156 x 10 1/2	S-3156 x 10 1/2			10 1/2					
23160K	SNP-3160 x 10 15/16	S-3160	N-060	P-60	10 15/16	-0.007	8 3/8	1 9/16	14 3/16	65.0
	SNP-3160 x 11	S-3160 x 11			11					
23164K	SNP-3164 x 11 15/16	S-3164	N-064	P-64	11 15/16	-0.007	9 7/64	1 21/32	15	70.0
	SNP-3164 x 12	S-3164 x 12			12					
	SNP-3168 x 12 1/2	S-3168 x 12 1/2			12 1/2					
23168K	SNP-3168 x 12 7/8	S-3168	N-068	P-68	12 7/8	-0.007	9 25/32	1 25/32	15 3/4	93.5
23172K	SNP-3172 x 13 7/16	S-3172	N-072	P-72	13 7/16	-0.007	11 27/64	1 25/32	16 1/2	120.0
	SNP-3172 x 13 1/2	S-3172 x 13 1/2			13 1/2					
23176K	SNP-3176 x 13 15/16	S-3176	N-076	P-76	13 15/16	-0.007	11 7/8	1 29/32	17 3/4	125.0
	SNP-3176 x 14	S-3176 x 14			14					
	SNP-3180 x 14 15/16	S-3180 x 14 15/16			14 15/16					
23180K	SNP-3180 x 15	S-3180	N-080	P-80	15	-0.007	12 21/32	2 1/16	18 1/2	140.0

⁽¹⁾Bold shaft sizes are standard. When ordering non-standard accessories, specify shaft size.

⁽²⁾Tolerance range is from +0 to value listed.

Continued on next page.

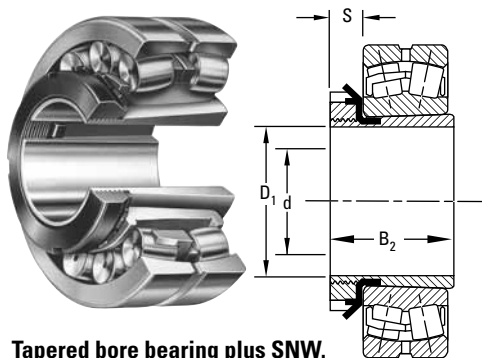

Tapered bore bearing plus SNW.

Continued from previous page.

Bearing No. ⁽¹⁾	Accessory Numbers				Shaft Dimensions		Adapter Dimensions			SNW/SNP Assembly Wt.
	Assembly	Sleeve	Locknut	Lockwasher Lockplate	Diameter d	Tolerance ⁽²⁾	B ₂	S	D ₁	
					in.	in.	in.	in.	in.	lbs.
23184K	SNP-3184 x 15 3/4	S-3184	N-084	P-84	15 3/4	-0.007	13 19/64	2 1/16	19 5/16	145.0
23188K	SNP-3188 x 16 1/2	S-3188	N-088	P-88	16 1/2	-0.007	13 61/64	2 3/8	20 1/2	229.0
23192K	SNP-3192 x 17	S-3192	N-092	P-92	17	-0.007	18 1/16	2 3/8	21 1/4	255.0
23196K	SNP-3196 x 18	S-3196	N-096	P-96	18	-0.007	15 5/32	2 3/8	22 1/16	293.0
231/500K	SNP-31/500 x 18 7/16	S-31/500	N-500	P-500	18 7/16	-0.007	16 1/2	2 45/64	22 13/16	315.0
231/530K	SNP-31/530 x 18 15/16 SNP-31/530 x 19 7/16	S-31/500 x 18 15/16 S-31/530 x 19 7/16	N-530	P-530	18 15/16 19 7/16	-0.007	17 17/64	2 45/64	24 13/16	355.0
231/560K	SNP-31/560 x 20 15/16	S-31/560	N-560	P-560	20 15/16	-0.007	17 59/64	2 61/64	25 9/16	408.0
231/600K	SNP-31/600 x 21 15/16	S-31/600	N-600	P-600	21 15/16	-0.007	18 55/64	2 61/64	27 9/16	516.0
231/630K	SNP-31/630 x 23 15/16	S-31/630	N-630	P-630	23 15/16	-0.007	19 51/64	2 61/64	28 3/4	556.0
231/670K	SNP-31/670 x 24 15/16	S-31/670	N-670	P-670	24 15/16	-0.007	21 1/32	3 3/64	30 11/16	759.0
231/710K	SNP-31/710 x 26 7/16	S-31/710	N-710	P-710	26 7/16	-0.007	21 15/16	3 37/64	32 11/16	833.0
231/750K	SNP-31/750 x 27 15/16	S-31/750	N-750	P-750	27 15/16	-0.007	22 63/64	3 37/64	34 1/4	997.0
231/800K	SNP-31/800 x 29 7/16	S-31/800	N-800	P-800	29 7/16	-0.007	19 1/64	3 37/64	36 1/4	1136.0
231/850K	SNP-31/850 x 31 7/16	S-31/850	N-850	P-850	31 7/16	-0.007	20 1/32	3 37/64	38 9/16	1303.0

⁽¹⁾Bold shaft sizes are standard. When ordering non-standard accessories, specify shaft size.

⁽²⁾Tolerance range is from +0 to value listed.



INCH ACCESSORIES – PUSH-TYPE SLEEVES

**PUSH-TYPE REMOVABLE SLEEVE,
LOCKNUT AND LOCKWASHER**

The chart below shows dimensions for adapter assemblies and components used in the mounting of tapered bore bearings on shafts.

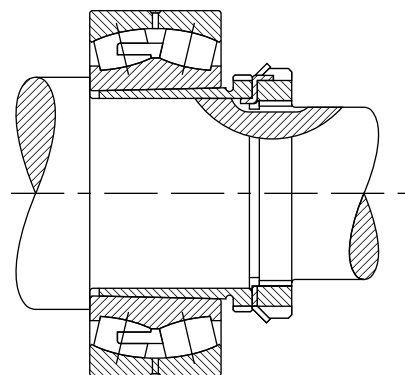

Bearing No.	Accessory Numbers				Shaft Dimensions		Adapter Dimensions			Removal Nut O.D. C	Sleeve Wt.
	Sleeve	Locknut	Lockwasher Lockplate	Removal Nut	Diameter d	Tolerance ⁽¹⁾	Pitch Dia. B	L	a		
					mm in.	mm in.	mm in.	mm in.	mm in.	mm in.	kg lbs.
SERIES 222K											
22216K	SK-8022	N-14	W-14	AN-18	70 2.7559	-0.10 -0.004	88.19 3.472	50 1.969	3.50 0.138	118.39 4.661	0.5 1.2
22217K	SK-8522	AN-15	W-15	AN-19	75 2.9528	-0.10 -0.004	93.35 3.675	52 2.047	3.50 0.138	125.55 4.943	0.6 1.4
22218K	SK-9022	AN-16	W-16	AN-20	80 3.1496	-0.10 -0.004	98.12 3.863	53 2.087	3.50 0.138	131.90 5.193	0.6 1.5
22219K	SK-9522	AN-17	W-17	AN-21	85 3.3465	-0.10 -0.004	103.28 4.066	57 2.244	4.00 0.157	138.25 5.443	0.8 1.8
22220K	SK-10022	AN-18	W-18	AN-22	90 3.5433	-0.10 -0.004	109.12 4.269	59 2.323	4.00 0.157	145.39 5.724	0.9 2.0
22222K	SK-11022	AN-20	W-20	ARN-22	100 3.9370	-0.10 -0.004	119.94 4.722	65 2.559	4.00 0.157	158.75 6.250	1.1 2.4
22224K	SK-12022	AN-22	W-22	ARN-24	110 4.3307	-0.13 -0.005	130.28 5.129	72 2.835	4.00 0.157	174.63 6.875	1.4 3.1
22226K	SK-13022	AN-22	W-22	ARN-26	115 4.5276	-0.13 -0.005	141.38 5.566	78 3.071	4.00 0.15.7	184.15 7.250	2.2 5.0
22228K	SK-14022	AN-24	W-24	RN-28	125 4.9213	-0.13 -0.005	152.73 6.013	82 3.228	5.00 0.197	200.03 7.875	2.6 5.8
22230K	SK-15022	AN-26	W-26	RN-30	135 5.3150	-0.13 -0.005	163.04 6.419	88 3.465	5.00 0.197	209.55 8.250	3.0 6.8
22232K	SK-16022	AN-28	W-28	RN-32	140 5.5118	-0.13 -0.005	173.76 6.841	96 3.780	5.00 0.197	225.43 8.875	4.5 9.9

⁽¹⁾Tolerance range is from +0 to value listed.

Continued on next page.

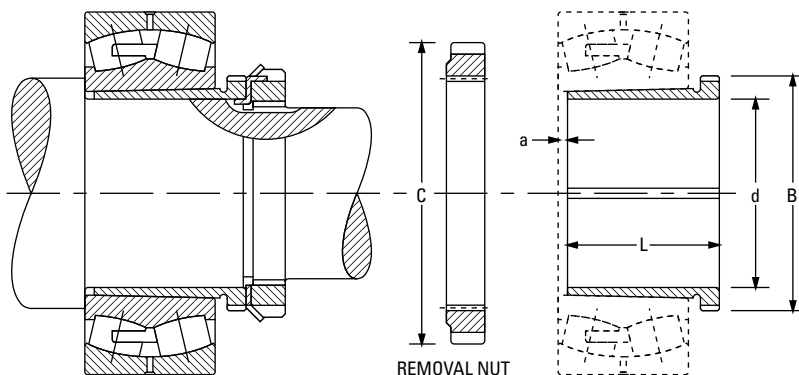

Tapered bore bearing mounted with push-type removable sleeve.

Continued from previous page.

Bearing No.	Accessory Numbers				Shaft Dimensions		Adapter Dimensions			Removal Nut O.D. C	Sleeve Wt.
	Sleeve	Locknut	Lockwasher Lockplate	Removal Nut	Diameter d	Tolerance ⁽¹⁾	Pitch Dia. B	L	a		
					mm in.	mm in.	mm in.	mm in.	mm in.	mm in.	kg lbs.
22234K	SK-17022	AN-30	W-30	RN-34	150 5.9055	-0.13 -0.005	184.07 7.247	104 4.095	5.00 0.197	234.95 9.250	5.2 11.5
22236K	SK-18022	AN-32	W-32	RN-36	160 6.2992	-0.13 -0.005	194.79 7.669	104 4.095	5.00 0.197	247.65 9.750	5.6 12.5
22238K	SK-19022	AN-34	W-34	RN-38	170 6.6929	-0.13 -0.005	205.92 8.107	112 4.409	5.00 0.197	269.88 10.625	6.5 14.5
22240K	SK-20022	AN-36	W-36	N-044	180 7.0866	-0.13 -0.005	217.02 8.544	118 4.646	5.00 0.197	279.53 11.005	7.4 16.3
22244K	SK-22022	AN-40	W-40	N-048	200 7.8740	-0.13 -0.005	236.98 9.330	130 5.118	6.00 0.236	290.65 11.443	8.8 19.6
22248K	SK-24022	N-44	W-44	N-052	220 8.6614	-0.15 -0.006	256.03 10.080	144 5.669	6.00 0.236	309.70 12.193	11.0 24.3
22252K	SK-26022	N-048	P-48	N-056	240 9.4488	-0.15 -0.006	276.66 10.892	155 6.102	6.00 0.236	330.33 13.005	14.0 30.9
22256K	SK-28022	N-052	P-52	RN-56	260 10.2362	-0.15 -0.006	301.27 11.861	155 6.102	8.00 0.315	425.45 16.750	15.0 33.1
22260K	SK-30022	N-056	P-56	RN-60	280 11.0236	-0.15 -0.006	325.88 12.830	170 6.693	8.00 0.315	416.10 16.382	17.7 39.2
22264K	SK-32022	N-060	P-60	RN-64	300 11.8110	-0.15 -0.006	345.72 13.611	180 7.087	10.00 0.394	431.8 17.000	21.0 46.3

⁽¹⁾Tolerance range is from +0 to value listed.

Continued on next page.

INCH ACCESSORIES – PUSH-TYPE SLEEVES – continued

PUSH-TYPE REMOVABLE SLEEVE, LOCKNUT AND LOCKWASHER

The chart below shows dimensions for adapter assemblies and components used in the tapered bore bearings on shafts.

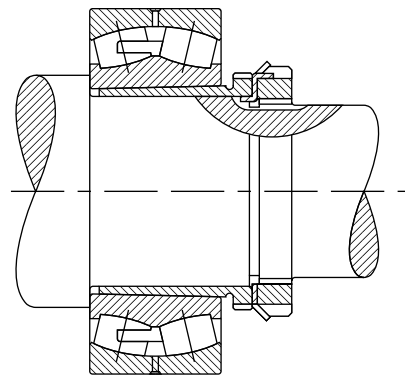

Continued from previous page.

Bearing No.	Accessory Numbers				Shaft Dimensions		Adapter Dimensions			Removal Nut O.D. C	Sleeve Wt.
	Sleeve	Locknut	Lockwasher Lockplate	Removal Nut	Diameter d	Tolerance ⁽¹⁾	Pitch Dia. B	L	a		
					mm in.	mm in.	mm in.	mm in.	mm in.	mm in.	kg lbs.
SERIES 223K											
22308K	SK-4023	N-07	W-07	N-09	35 1.3780	-0.08 -0.003	43.94 1.730	40 1.575	3.00 0.118	64.41 2.536	0.1 0.2
22309K	SK-4523	N-08	W-08	N-10	40 1.5748	-0.08 -0.003	49.02 1.930	44 1.732	3.00 0.118	68.40 2.693	0.1 0.3
22310K	SK-5023	N-09	W-09	RN-10	45 1.7717	-0.08 -0.003	55.04 2.167	50 1.969	3.00 0.118	76.20 3.000	0.2 0.4
22311K	SK-5523	N-10	W-10	RN-11	50 1.9685	-0.08 -0.003	60.20 2.370	54 2.126	3.00 0.118	81.76 3.219	0.2 0.5
22312K	SK-6023	N-11	W-11	RN-12	55 2.1654	-0.10 -0.004	65.76 2.589	57 2.244	3.50 0.138	87.33 3.438	0.3 0.6
22313K	SK-6523	N-12	W-12	AN-15	60 2.3622	-0.10 -0.004	73.10 2.878	61 2.402	3.50 0.138	98.55 3.880	0.3 0.8
22314K	SK-7023	N-12	W-12	AN-16	60 2.3622	-0.10 -0.004	78.28 3.082	65 2.559	3.50 0.138	105.69 4.161	0.6 1.5
22315K	SK-7523	N-13	W-13	AN-17	65 2.5591	-0.10 -0.004	83.44 3.285	69 2.717	3.50 0.138	112.04 4.411	0.8 1.7
22316K	SK-8023	N-14	W-14	AN-18	70 2.7559	-0.10 -0.004	88.19 3.472	72 2.835	3.50 0.138	118.39 4.661	0.9 2.0
22317K	SK-8523	AN-15	W-15	AN-19	75 2.9528	-0.10 -0.004	93.35 3.675	75 2.953	3.50 0.138	125.55 4.943	1.0 2.2
22318K	SK-9023	AN-16	W-16	AN-20	80 3.1496	-0.10 -0.004	98.12 3.863	80 3.150	3.50 0.138	131.90 5.193	1.1 2.5
22319K	SK-9523	AN-17	W-17	AN-21	85 3.3465	-0.10 -0.004	103.28 4.066	85 3.346	4.00 0.157	138.25 5.443	1.3 2.9
22320K	SK-10023	AN-18	W-18	AN-22	90 3.5433	-0.10 -0.004	109.12 4.269	90 3.543	4.00 0.157	145.39 5.724	1.5 3.3

⁽¹⁾Tolerance range is from +0 to value listed.

Continued on next page.

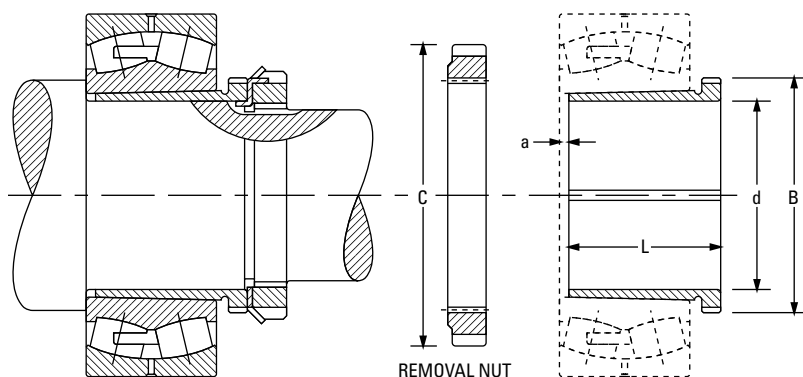

Tapered bore bearing mounted with push-type removable sleeve.

Continued from previous page.

Bearing No.	Accessory Numbers				Shaft Dimensions		Adapter Dimensions			Removal Nut O.D. C	Sleeve Wt.
	Sleeve	Locknut	Lockwasher Lockplate	Removal Nut	Diameter d	Tolerance ⁽¹⁾	Pitch Dia. B	L	a		
					mm in.	mm in.	mm in.	mm in.	mm in.	mm in.	kg lbs.
22322K	SK-11023	AN-20	W-20	ARN-22	100 3.9370	-0.10 -0.004	119.94 4.722	98 3.858	4.00 0.157	158.75 6.250	1.9 4.2
22324K	SK-12023	AN-22	W-22	ARN-24	110 4.3307	-0.13 -0.005	130.28 5.129	105 4.134	4.00 0.157	174.63 6.875	2.2 5.0
22326K	SK-13023	AN-22	W-22	ARN-26	115 4.5276	-0.13 -0.005	141.38 5.566	115 4.528	4.00 0.157	184.15 7.250	3.6 8.0
22328K	SK-14023	AN-24	W-24	RN-28	125 4.9213	-0.13 -0.005	152.73 6.013	125 4.921	5.00 0.197	200.03 7.875	4.3 9.5
22330K	SK-15023	AN-26	W-26	RN-30	135 5.3150	-0.13 -0.005	163.04 6.419	135 5.315	5.00 0.197	209.55 8.250	5.1 11.4
22332K	SK-16023	AN-28	W-28	RN-32	140 5.5118	-0.13 -0.005	173.76 6.841	140 5.512	6.00 0.236	225.43 8.875	7.0 15.5
22334K	SK-17023	AN-30	W-30	RN-34	150 5.9055	-0.13 -0.005	184.07 7.247	146 5.748	6.00 0.236	234.95 9.250	7.8 17.2
22336K	SK-18023	AN-32	W-32	RN-36	160 6.2992	-0.13 -0.005	194.79 7.669	154 6.063	6.00 0.236	247.65 9.750	9.1 20.2
22338K	SK-19023	AN-34	W-34	RN-38	170 6.6929	-0.13 -0.005	205.92 8.107	160 6.299	7.00 0.276	269.88 10.625	10.0 22.1
22340K	SK-20023	AN-36	W-36	N-044	180 7.0866	-0.13 -0.005	217.02 8.544	170 6.693	7.00 0.276	279.53 11.005	11.4 25.2
22344K	SK-22023	AN-40	W-40	N-048	200 7.8740	-0.13 -0.005	236.98 9.330	181 7.126	8.00 0.315	290.65 11.443	13.3 29.5
22348K	SK-24023	N-44	W-44	N-052	220 8.6614	-0.15 -0.006	256.03 10.080	189 7.441	8.00 0.315	309.70 12.193	15.5 34.2
22352K	SK-26023	N-048	P-48	N-056	240 9.4488	-0.15 -0.006	276.66 10.892	200 7.874	8.00 0.315	330.33 13.005	18.2 40.2
22356K	SK-28023	N-052	P-52	RN-56	260 10.2362	-0.15 -0.006	301.27 11.861	210 8.268	10.00 0.394	425.45 16.75	22.0 48.5

⁽¹⁾Tolerance range is from +0 to value listed.

INCH ACCESSORIES – LOCKNUTS AND LOCKWASHERS

- The chart below shows dimensions for locknuts and lockwashers used in the mounting of straight bore bearings on shafts.
- Other dimensions and tolerances related to shaft configurations are also shown.
- Dimensions are presented according to bearing bore size and are applicable to bearings in the various series (e.g., 222, 223, etc.).

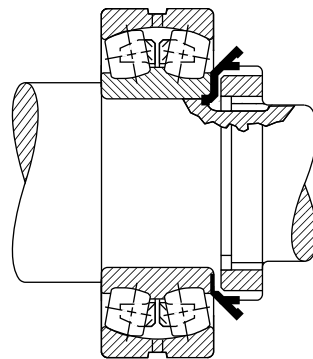

Bearing Bore	Locknut	Lockwasher	Threads Per Inch	Threads					
				Major Dia.		Pitch Dia.		Minor Dia.	Relief Dia. A
				Max.	Min.	Max.	Min.		
mm				mm in.	mm in.	mm in.	mm in.	mm in.	mm in.
35	N 07	W 07	18	34.950 1.3760	34.740 1.3678	34.030 1.3399	33.930 1.3359	33.220 1.3078	32.820 1.2922
40	N 08	W 08	18	39.700 1.5630	39.490 1.5548	38.780 1.5269	38.670 1.5224	37.970 1.4948	37.570 1.4792
45	N 09	W 09	18	44.880 1.7670	44.670 1.7588	43.960 1.7309	43.850 1.7264	43.150 1.6988	42.750 1.6832
50	N 10	W 10	18	49.960 1.9670	49.750 1.9588	49.050 1.9309	48.930 1.9264	48.230 1.8988	47.830 1.8832
55	N 11	W 11	18	54.790 2.1570	54.580 2.1488	53.870 2.1209	53.740 2.1158	53.060 2.0888	52.660 2.0732
60	N 12	W 12	18	59.940 2.3600	59.740 2.3518	59.030 2.3239	58.900 2.3188	58.210 2.2918	57.820 2.2762
65	N 13	W 13	18	64.720 2.5480	64.510 2.5398	63.800 2.5119	63.670 2.5068	62.990 2.4798	62.590 2.4642
70	N 14	W 14	18	69.880 2.7510	69.670 2.7428	68.960 2.7149	68.830 2.7098	68.140 2.6828	67.750 2.6672
75	AN 15	W 15	12	74.500 2.9330	74.210 2.9218	73.120 2.8789	72.990 2.8735	71.900 2.8308	71.110 2.7995
80	AN 16	W 16	12	79.680 3.1370	79.400 3.1258	78.310 3.0829	78.160 3.0770	77.080 3.0348	76.290 3.0035
85	AN 17	W 17	12	84.840 3.3400	84.550 3.3288	83.460 3.2859	83.310 3.2800	82.240 3.2378	81.450 3.2065
90	AN 18	W 18	12	89.590 3.5270	89.300 3.5158	88.210 3.4729	88.020 3.4655	86.990 3.4248	86.200 3.3935
95	AN 19	W 19	12	94.740 3.7300	94.460 3.7188	93.370 3.6759	93.180 3.6685	92.150 3.6278	91.350 3.5965
100	AN 20	W 20	12	99.520 3.9180	99.230 3.9068	98.140 3.8639	97.960 3.8565	96.920 3.8158	96.130 3.7845
105	AN 21	W 21	12	104.700 4.1220	104.410 4.1108	103.320 4.0679	103.110 4.0596	102.100 4.0198	101.310 3.9885
110	AN 22	W 22	12	109.860 4.3250	109.570 4.3138	108.480 4.2709	108.270 4.2626	107.260 4.2228	106.460 4.1915
120	AN 24	W 24	12	119.790 4.7160	119.500 4.7048	118.410 4.6619	118.200 4.6536	117.190 4.6138	116.400 4.5825

⁽¹⁾See page D-76, table D-20 for suggested S-3 shaft limits.

⁽²⁾For W, L, H, S and M, tolerance is -0 to +0.4 mm, -0 to +1/64 in.

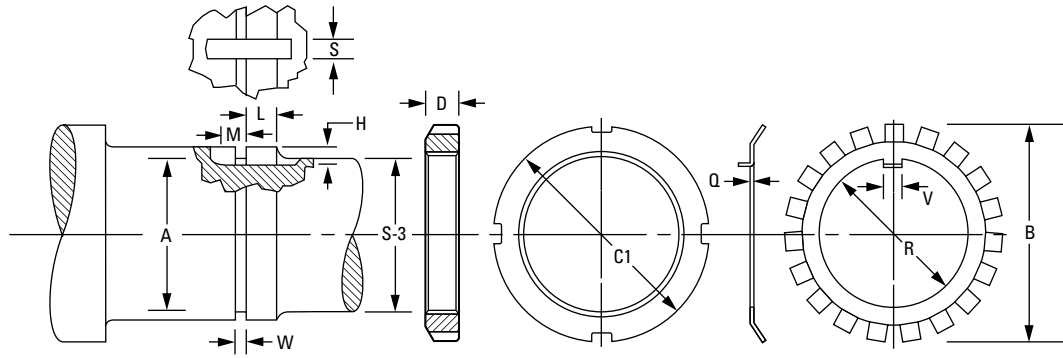

Shaft						Locknut		Lockwasher			
S-3 ⁽¹⁾	W ⁽²⁾	L ⁽²⁾	H ⁽²⁾	S ⁽²⁾	M ⁽²⁾	C1	D	Q	R	B	V
mm in.	mm in.	mm in.	mm in.	mm in.	mm in.	mm in.	mm in.	mm in.	mm in.	mm in.	mm in.
31.750 1 ¼	2.4 ¾	12.7 ½	2.4 ¾	4.8 ¾	3.2 ⅛	52.39 2 ⅛	11.40 0.448	1.30 0.050	36.00 1.416	57.20 2 ¼	4.50 0.176
36.510 1 ⅞	3.2 ⅛	13.5 ½	2.4 ¾	7.9 ⅝	3.2 ⅛	57.15 2 ¼	11.40 0.448	1.50 0.058	40.70 1.603	62.70 2 ⅝	7.40 0.290
42.860 1 ⅞	3.2 ⅛	13.5 ½	2.4 ¾	7.9 ⅝	4.0 ⅝	64.30 2 ⅞	11.40 0.448	1.50 0.058	46.20 1.817	69.50 2 ⅞	7.40 0.290
47.630 1 ⅞	3.2 ⅛	15.1 ⅝	2.4 ¾	7.9 ⅝	4.0 ⅝	68.30 2 ⅞	13.00 0.510	1.50 0.058	51.20 2.017	74.20 2 ⅞	7.40 0.290
52.390 2 ⅛	3.2 ⅛	15.1 ⅝	3.2 ⅛	7.9 ⅝	4.0 ⅝	75.40 2 ¾	13.00 0.510	1.60 0.063	56.10 2.207	79.00 3 ¼	7.40 0.290
57.150 2 ¼	3.2 ⅛	15.9 ⅝	3.2 ⅛	7.9 ⅝	4.0 ⅝	80.20 3 ⅞	13.70 0.541	1.60 0.063	61.60 2.425	85.00 3 ⅞	7.40 0.290
61.910 2 ⅞	3.2 ⅛	16.7 ⅝	3.2 ⅛	7.9 ⅝	4.0 ⅝	85.70 3 ⅞	14.60 0.573	1.60 0.063	66.40 2.613	90.90 3 ⅞	7.40 0.290
66.680 2 ⅞	3.2 ⅛	16.7 ⅝	3.2 ⅛	7.9 ⅝	6.4 ¼	92.10 3 ⅞	14.60 0.573	1.60 0.063	71.50 2.816	97.20 3 ⅞	7.40 0.290
71.440 2 ⅞	4.0 ⅝	17.5 ⅝	3.2 ⅛	7.9 ⅝	6.4 ¼	98.40 3 ⅞	15.30 0.604	1.60 0.072	76.30 3.003	104.40 4 ⅞	7.40 0.290
76.200 3	4.0 ⅝	17.5 ⅝	3.2 ⅛	9.5 ⅝	6.4 ¼	105.60 4 ⅞	15.30 0.604	1.80 0.072	81.50 3.207	111.10 4 ⅞	9.00 0.353
80.960 3 ⅞	4.0 ⅝	16.7 ⅝	3.2 ⅛	9.5 ⅝	6.4 ¼	111.90 4 ⅞	16.10 0.635	1.80 0.072	87.00 3.425	117.50 4 ⅞	9.00 0.353
85.730 3 ⅞	4.0 ⅝	20.6 ⅞	4.0 ⅝	9.5 ⅝	6.4 ¼	118.30 4 ⅞	17.70 0.698	2.40 0.094	91.70 3.612	125.40 4 ⅞	9.00 0.353
90.490 3 ⅞	4.0 ⅝	21.4 ⅞	4.0 ⅝	9.5 ⅝	6.4 ¼	125.40 4 ⅞	18.50 0.729	2.40 0.094	97.30 3.830	132.60 5 ⅞	9.00 0.353
96.840 3 ⅞	4.0 ⅝	22.2 ⅞	4.0 ⅝	9.5 ⅝	7.9 ⅝	131.80 5 ⅞	19.30 0.760	2.40 0.094	102.10 4.018	139.70 5 ½	9.00 0.353
100.010 3 ⅞	4.0 ⅝	22.2 ⅞	4.0 ⅝	9.5 ⅝	7.9 ⅝	138.10 5 ⅞	19.30 0.760	2.40 0.094	107.20 4.222	144.90 5 ⅞	9.00 0.353
106.360 4 ⅞	4.0 ⅝	23 ⅞	4.8 ⅝	9.5 ⅝	7.9 ⅝	145.30 5 ⅞	20.10 0.791	3.20 0.125	112.40 4.425	154.00 6 ⅞	9.00 0.353
115.890 4 ⅞	4.0 ⅝	23.8 ⅞	4.8 ⅝	9.5 ⅝	7.9 ⅝	155.60 6 ⅞	20.90 0.823	3.20 0.125	122.70 4.831	164.30 6 ⅞	9.00 0.353

⁽¹⁾See page D-76, table D-20 for suggested S-3 shaft limits.

⁽²⁾For W, L, H, S and M, tolerance is -0 to +0.4 mm, -0 to +1/64 in.

Continued on next page.

INCH ACCESSORIES – LOCKNUTS AND LOCKWASHERS – continued

- The chart below shows dimensions for locknuts and lockwashers used in the mounting of straight bore bearings on shafts.
- Other dimensions and tolerances related to shaft configurations are also shown.
- Dimensions are presented according to bearing bore size and are applicable to bearings in the various series (e.g., 222 and 223, etc.).

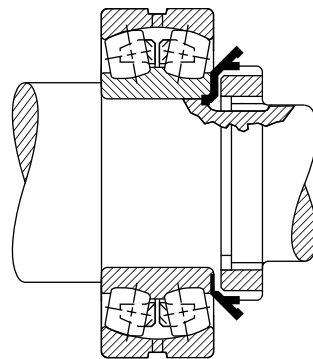

Continued from previous page.

Bearing Bore	Locknut	Lockwasher	Threads Per Inch	Threads					
				Major Dia.		Pitch Dia.		Minor Dia.	Relief Dia. A
				Max.	Min.	Max.	Min.		
mm				mm in.	mm in.	mm in.	mm in.	mm in.	mm in.
130	AN 26	W 26	12	129.690 5.1060	129.410 5.0948	128.320 5.0519	128.110 5.0436	127.100 5.0038	126.300 4.9725
140	AN 28	W 28	12	139.620 5.4970	139.340 5.4858	138.250 5.4429	138.040 5.4346	137.030 5.3948	136.230 5.3635
150	AN 30	W 30	12	149.560 5.8880	149.270 5.8768	148.180 5.8339	147.970 5.8256	146.960 5.7858	146.160 5.7545
160	AN 32	W 32	8	159.610 6.2840	159.230 6.2688	157.550 6.2028	157.320 6.1937	155.720 6.1306	154.920 6.0993
170	AN 34	W 34	8	169.140 6.6590	168.750 6.6438	167.080 6.5778	166.850 6.5687	165.240 6.5056	164.450 6.4743
180	AN 36	W 36	8	179.480 7.0660	179.090 7.0508	177.410 6.9848	177.180 6.9757	175.580 6.9126	174.790 6.8813
190	AN 38	W 38	8	189.790 7.4720	189.400 7.4568	187.730 7.3908	187.500 7.3817	185.890 7.3186	185.100 7.2873
200	AN 40	W 40	8	199.310 7.8470	198.930 7.8318	197.250 7.7658	196.960 7.7544	195.420 7.6936	194.620 7.6623
220	N 044	W 44	8	219.150 8.6280	218.770 8.6128	217.090 8.5468	216.780 8.5347	215.250 8.4746	214.460 8.4433

⁽¹⁾See page D-76, table D-20 for suggested S-3 shaft limits.

⁽²⁾For W, L, H, S and M, tolerance is -0 to +0.4 mm, -0 to +1/64 in.

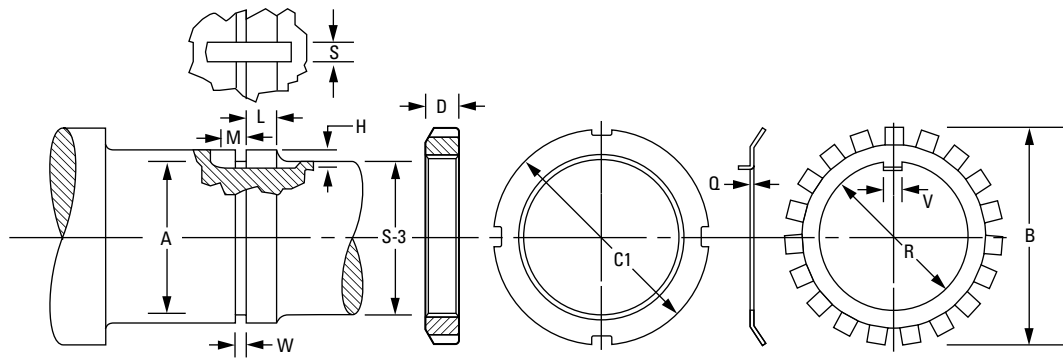

Shaft						Locknut		Lockwasher			
S-3 ⁽¹⁾	W ⁽²⁾	L ⁽²⁾	H ⁽²⁾	S ⁽²⁾	M ⁽²⁾	C1	D	Q	R	B	V
mm in.	mm in.	mm in.	mm in.	mm in.	mm in.	mm in.	mm in.	mm in.	mm in.	mm in.	mm in.
125.410 4 15/16	4.0 5/32	25.4 1	4.8 3/16	12.7 1/2	7.9 5/16	171.50 6 3/4	22.50 0.885	3.20 0.125	132.70 5.226	178.60 7 1/32	11.10 0.435
134.940 5 5/16	4.0 5/32	27 1 1/16	4.8 3/16	15.9 5/8	7.9 5/16	180.20 7 3/32	24.10 0.948	3.20 0.125	142.70 5.617	188.90 7 7/16	15.00 0.590
146.050 5 3/4	4.0 5/32	28.6 1 1/8	5.6 7/32	15.9 5/8	9.5 3/8	195.30 7 11/16	24.90 0.979	4.00 0.156	152.90 6.018	204.80 8 1/16	15.00 0.590
153.990 6 1/16	6.4 1/4	30.2 1 3/16	6.0 15/64	15.9 5/8	9.5 3/8	204.80 8 1/16	26.40 1.041	4.00 0.156	163.20 6.424	214.30 8 7/16	15.00 0.590
163.510 6 7/16	6.4 1/4	31 1 1/32	6.0 15/64	19.1 3/4	9.5 3/8	219.90 8 27/32	27.30 1.073	4.00 0.156	172.70 6.799	230.20 9 1/16	18.20 0.715
174.630 6 5/8	6.4 1/4	31.8 1 1/4	6.0 15/64	19.1 3/4	9.5 3/8	230.20 9 1/16	28.00 1.104	4.00 0.156	183.00 7.206	239.70 9 5/16	18.20 0.715
184.150 7 1/4	6.4 1/4	32.5 1 3/32	6.0 15/64	19.1 3/4	9.5 3/8	240.50 9 15/32	28.80 1.135	4.00 0.156	193.30 7.612	250.80 9 3/8	18.20 0.715
193.680 7 5/8	6.4 1/4	34.1 1 11/32	6.0 15/64	22.2 7/8	9.5 3/8	250.00 9 27/32	30.40 1.198	4.00 0.156	203.60 8.017	261.90 10 5/16	21.30 0.840
211.140 8 5/16	6.4 1/4	34.9 1 3/8	9.5 3/8	27.0 1 1/16	9.5 3/8	279.40 11	31.80 1.250	3.20 0.125	221.10 8.703	290.50 11 7/16	23.90 0.940

⁽¹⁾See page D-76, table D-20 for suggested S-3 shaft limits.

⁽²⁾For W, L, H, S and M, tolerance is -0 to +0.4 mm, -0 to +1/64 in.

INCH ACCESSORIES – LOCKNUTS AND LOCKPLATES

- The chart below shows dimensions for locknuts and lockplates used in the mounting of straight bore bearings on shafts.
- Other dimensions and tolerances related to shaft configurations are also shown.
- Dimensions are presented according to bearing bore size and are applicable to bearings in the various series (e.g., 222, 223, etc.).

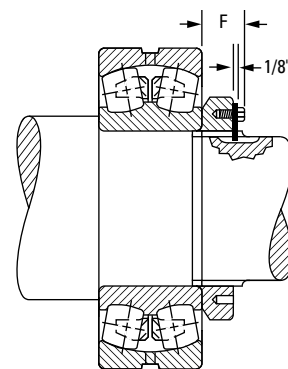

Bearing Bore	Locknut	Lockplate	Threads Per Inch	Threads					
				Major Dia.		Pitch Dia.		Minor Dia.	Relief Dia. A
				Max.	Min.	Max.	Min.		
mm				mm in.	mm in.	mm in.	mm in.	mm in.	mm in.
240	N 048	P 48	6	239.83 9.442	239.31 9.4218	237.08 9.3337	236.76 9.3213	234.63 9.2374	233.44 9.1905
260	N 052	P 52	6	258.88 10.192	258.36 10.1718	256.13 10.0837	255.8 10.0707	253.68 9.9874	252.49 9.9405
280	N 056	P 56	6	279.50 11.004	278.99 10.9838	276.75 10.8957	276.42 10.8827	274.31 10.7994	273.11 10.7525
300	N 060	P 60	6	299.34 11.785	298.83 11.7648	296.59 11.6767	296.26 11.6637	294.14 11.5804	292.95 11.5335
320	N 064	P 64	6	319.08 12.562	318.56 12.5418	316.32 12.4537	315.98 12.4402	313.88 12.3574	312.69 12.3105
340	N 068	P 68	5	337.90 13.303	337.49 13.287	335.36 13.203	334.95 13.187	332.31 13.083	331.11 13.036
360	N 072	P 72	5	359.00 14.134	358.60 14.118	356.46 14.034	356.06 14.018	353.42 13.914	352.22 13.867
380	N 076	P 76	5	378.99 14.921	378.59 14.905	376.45 14.821	376.05 14.805	373.41 14.701	372.21 14.654
400	N 080	P 80	5	399.01 15.709	398.60 15.693	396.47 15.609	396.06 15.593	393.42 15.489	392.23 15.442
420	N 084	P 84	5	419.00 16.496	418.59 16.480	416.46 16.396	416.05 16.380	413.41 16.276	412.22 16.229
440	N 088	P 88	5	438.99 17.283	438.58 17.267	436.45 17.183	436.05 17.167	433.40 17.063	432.21 17.016
460	N 092	P 92	5	459.00 18.071	458.60 18.055	456.46 17.971	456.06 17.955	453.42 17.851	452.22 17.804
480	N 096	P 96	5	478.99 18.858	478.59 18.842	476.45 18.758	476.05 18.742	473.41 18.638	472.21 18.591

⁽¹⁾See page D-76, table D-20 for suggested S-3 shaft limits.

⁽²⁾C is outer-ring width that may be obtained from bearing dimension tables.

⁽³⁾For L, H, S and M, tolerance is -0 to +1/64 in., -0 to + 0.4 mm.

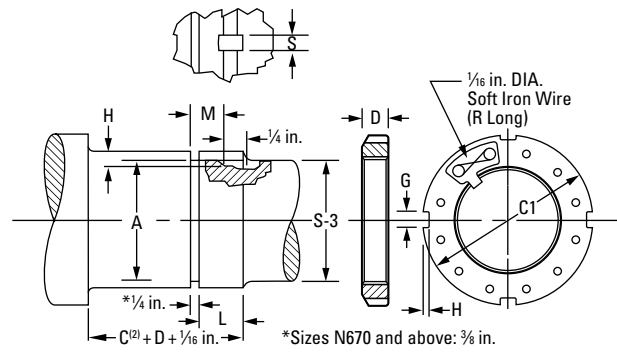

Shaft					Locknut/Lockplate					
S-3 ⁽¹⁾	L ⁽³⁾	H ⁽³⁾	S ⁽³⁾	M ⁽³⁾	C1	D	G	H ±0.25 mm ±0.010 in.	R	F
mm in.	mm in.	mm in.	mm in.	mm in.	mm in.	mm in.	mm in.	mm in.	mm in.	mm in.
233.36 9 3/16	42.86 1 11/16	11.1 7/16	28.6 1 1/8	34.9 1 3/8	290.5 11 7/16	34.1 1 1/2	22.48 0.885	9.5 3/8	203.2 8	43.26 1 45/64
252.41 9 15/16	45.24 1 25/32	11.1 7/16	30.2 1 3/16	37.3 1 15/32	309.6 12 3/16	35.7 1 13/32	22.48 0.885	9.5 3/8	228.6 9	44.85 1 49/64
273.05 10 3/4	47.63 1 7/8	11.1 7/16	31.8 1 1/4	39.7 1 5/16	330.2 13	38.1 1 1/2	25.65 1.010	9.5 3/8	228.6 9	47.23 1 55/64
292.1 11 1/2	49.21 1 15/16	11.1 7/16	34.9 1 3/8	41.3 1 5/8	360.4 14 3/16	39.7 1 7/16	25.65 1.010	12.7 1/2	254.0 10	50.01 1 31/32
312.74 12 3/16	51.59 2 1/32	11.1 7/16	36.5 1 7/16	43.7 1 23/32	381.0 15	42.1 1 21/32	25.65 1.010	12.7 1/2	254.0 10	52.39 2 1/16
331.79 13 1/16	56.36 2 3/32	11.1 7/16	38.1 1 1/2	48.4 1 29/32	400.1 15 3/4	45.2 1 25/32	25.65 1.010	12.7 1/2	279.4 11	55.56 2 3/16
350.84 13 13/16	56.36 2 3/32	12.7 1/2	38.1 1 1/2	48.4 1 29/32	419.1 16 1/2	45.2 1 25/32	32.00 1.260	12.7 1/2	279.4 11	55.56 2 3/16
371.48 14 5/8	59.53 2 11/32	12.7 1/2	38.1 1 1/2	51.59 2 1/32	450.9 17 3/4	48.4 1 29/32	32.00 1.260	15.1 19/32	304.8 12	61.12 2 19/32
390.53 15 3/8	63.50 2 1/2	12.7 1/2	41.3 1 5/8	55.6 2 3/16	469.9 18 1/2	52.4 2 1/16	32.00 1.260	15.1 19/32	330.2 13	65.09 2 9/16
411.16 16 3/16	63.50 2 1/2	12.7 1/2	41.3 1 5/8	55.6 2 3/16	490.5 19 5/16	52.4 2 1/16	35.18 1.385	15.1 19/32	330.2 13	65.09 2 9/16
431.80 17	71.44 2 13/16	12.7 1/2	46.0 1 13/16	63.50 2 1/2	520.7 20 1/2	60.3 2 3/8	35.18 1.385	15.1 19/32	355.6 14	75.41 2 31/32
450.85 17 3/4	71.44 2 13/16	12.7 1/2	46.0 1 13/16	63.50 2 1/2	539.8 21 1/4	60.3 2 3/8	35.18 1.385	15.1 19/32	406.4 16	75.41 2 31/32
469.9 18 1/2	71.44 2 13/16	12.7 1/2	46.0 1 13/16	63.50 2 1/2	560.4 22 1/16	60.3 2 3/8	38.35 1.510	15.1 19/32	406.4 16	75.41 2 31/32

⁽¹⁾See page D-76, table D-20 for suggested S-3 shaft limits.

⁽²⁾C is outer-ring width that may be obtained from bearing dimension tables.

⁽³⁾For L, H, S and M, tolerance is -0 to +1/64 in., -0 to +0.4 mm.

Continued on next page.

**INCH ACCESSORIES –
LOCKNUTS AND LOCKPLATES** – *continued*

- The chart below shows dimensions for locknuts and lockplates used in the mounting of straight bore bearings on shafts.
- Other dimensions and tolerances related to shaft configurations are also shown.
- Dimensions are presented according to bearing bore size and are applicable to bearings in the various series (e.g., 222, 223, etc.).

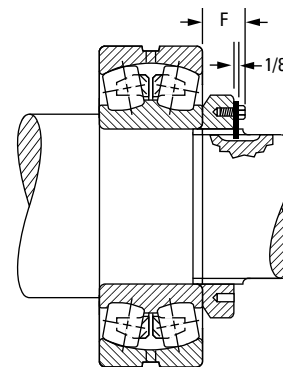

Continued from previous page.

Bearing Bore	Locknut	Lockplate	Threads Per Inch	Threads					
				Major Dia.		Pitch Dia.		Minor Dia.	Relief Dia. A
				Max.	Min.	Max.	Min.		
mm				mm in.	mm in.	mm in.	mm in.	mm in.	mm in.
500	N 500	P 500	5	499.01 19.646	498.60 19.630	496.47 19.546	496.06 19.530	493.42 19.426	492.23 19.379
530	N 530	P 530	4	529.01 20.827	528.50 20.807	525.83 20.702	525.32 20.682	522.15 20.557	520.55 20.494
560	N 560	P 560	4	559.00 22.008	558.50 21.988	555.83 21.883	555.32 21.863	552.15 21.738	550.55 21.675
600	N 600	P 600	4	599.01 23.583	598.50 23.563	595.83 23.458	595.33 23.438	592.15 23.313	590.55 23.250
630	N 630	P 630	4	629.01 24.764	628.50 24.744	625.83 24.639	625.32 24.619	622.15 24.494	520.55 24.431
670	N 670	P 670	4	669.01 26.339	668.50 26.319	665.84 26.214	665.33 26.194	662.15 26.069	660.55 26.006
710	N 710	P 710	3	709.02 27.914	708.33 27.887	704.77 27.747	704.09 27.720	700.02 27.56	698.42 27.497
750	N 750	P 750	3	749.02 29.489	748.34 29.462	744.78 29.322	744.09 29.295	740.03 29.135	738.43 29.072
800	N 800	P 800	3	799.01 31.457	798.32 31.430	794.77 31.290	794.08 31.263	790.02 31.103	788.42 31.040
850	N 850	P 850	3	849.02 33.426	848.34 33.399	844.78 33.259	844.09 33.232	840.03 33.072	838.43 33.009
900	N 900	P 900	3	899.01 35.394	898.32 35.367	894.77 35.227	894.08 35.200	890.02 35.040	888.42 34.977
950	N 950	P 950	3	949.02 37.363	948.33 37.336	944.78 37.196	944.09 37.169	940.03 37.009	938.43 36.946

⁽¹⁾See page D-76, table D-20 for suggested S-3 shaft limits.

⁽²⁾C is outer-ring width that may be obtained from bearing dimension tables.

⁽³⁾For L, H, S and M, tolerance is -0 to +1/4 in., -0 to + 0.4 mm.

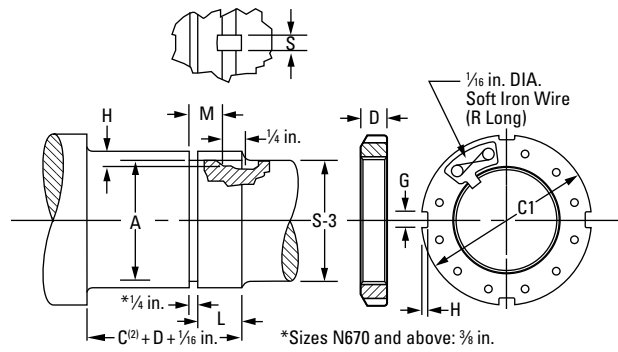

Shaft					Locknut/Lockplate					
S-3 ⁽¹⁾	L ⁽³⁾	H ⁽³⁾	S ⁽³⁾	M ⁽³⁾	C1	D	G	H ±0.25 mm ±0.010 in.	R	F
mm in.	mm in.	mm in.	mm in.	mm in.	mm in.	mm in.	mm in.	mm in.	mm in.	mm in.
489.0 19 1/4	79.4 3 1/8	12.7 1/2	46.0 1 13/16	71.4 2 13/16	579.4 22 13/16	68.3 2 11/16	38.35 1.510	15.1 19/32	406.4 16	83.3 3 3/32
517.5 20 3/8	79.4 3 1/8	12.7 1/2	46.0 1 13/16	71.4 2 13/16	630.2 24 13/16	68.3 2 11/16	41.53 1.635	20.6 13/16	425.5 16 3/4	83.3 3 3/32
549.3 21 5/8	85.7 3 3/8	12.7 1/2	46.0 1 13/16	77.8 3 1/16	649.3 25 5/16	74.6 2 5/16	41.53 1.635	20.6 13/16	476.3 18 3/4	89.7 3 11/32
587.4 23 1/8	85.7 3 3/8	12.7 1/2	46.0 1 13/16	77.8 3 1/16	700.1 27 5/16	74.6 2 5/16	41.53 1.635	20.6 13/16	508.0 20	89.7 3 11/32
619.1 24 3/8	85.7 3 3/8	12.7 1/2	50.8 2	77.8 3 1/16	730.3 28 3/4	74.6 2 5/16	47.88 1.885	20.6 13/16	520.7 20 1/2	92.1 3 3/8
657.2 25 7/8	90.5 3 9/16	12.7 1/2	50.8 2	82.6 3 1/4	779.5 30 11/16	79.4 3 1/8	47.88 1.885	20.6 13/16	546.1 21 1/2	96.8 3 13/16
695.3 27 3/8	101.6 4	15.9 5/8	50.8 2	93.7 3 11/16	830.3 32 11/16	90.5 3 3/16	51.30 2.020	25.4 1	571.5 22 1/2	108.0 4 1/4
736.6 29	101.6 4	15.9 5/8	50.8 2	93.7 3 11/16	870.0 34 1/4	90.5 3 3/16	57.66 2.270	25.4 1	584.2 23	108.0 4 1/4
787.4 31	101.6 4	15.9 5/8	50.8 2	93.7 3 11/16	920.8 36 1/4	90.5 3 3/16	57.66 2.270	25.4 1	616.0 24 1/4	108.0 4 1/4
835.0 32 7/8	101.6 4	15.9 5/8	50.8 2	93.7 3 11/16	979.5 38 3/16	90.5 3 3/16	64.01 2.520	25.4 1	647.7 25 1/2	108.0 4 1/4
885.8 34 7/8	111.1 4 3/8	15.9 5/8	50.8 2	103.2 4 1/16	1030.3 40 9/16	100.0 3 1/16	64.01 2.520	25.4 1	666.8 26 1/4	117.5 4 5/8
933.5 36 3/4	114.3 4 1/2	19.1 3/4	50.8 2	108 4 1/4	1092.2 43	100.0 3 15/16	64.01 2.520	25.4 1	692.2 27 1/4	117.5 4 5/8

⁽¹⁾See page D-76, table D-20 for suggested S-3 shaft limits.

⁽²⁾C is outer-ring width that may be obtained from bearing dimension tables.

⁽³⁾For L, H, S and M, tolerance is -0 to +1/64 in., -0 to +0.4 mm.



INCH HMVC HYDRAULIC NUTS

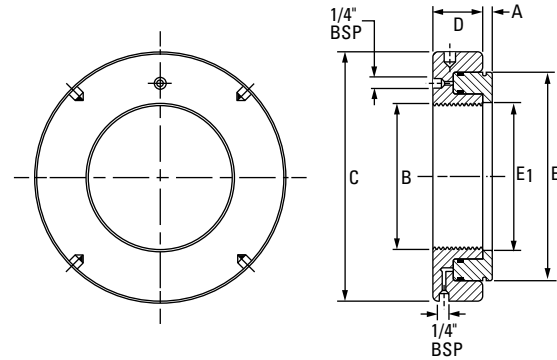

Part No.	Major Dia. B	Threads Per Inch	Dimensions					Piston Length of Travel	Piston Area	Assembly Wt.
			C	D	E	E ₁	A			
	in.		in.	in.	in.	in.	in.	in.	in. ²	lbs.
HMVC - 10	1.967	18	4.488	1.496	3.386	2.008	0.157	0.197	4.5	5.5
HMVC - 12	2.360	18	4.921	1.496	3.701	2.402	0.197	0.197	5.0	6.2
HMVC - 13	2.548	18	5.315	1.496	3.976	2.598	0.197	0.197	5.4	6.6
HMVC - 14	2.751	18	5.512	1.496	4.213	2.795	0.197	0.197	6.0	7.3
HMVC - 15	2.933	12	5.709	1.496	4.409	2.992	0.197	0.197	6.3	7.7
HMVC - 16	3.137	12	5.906	1.496	4.606	3.189	0.197	0.197	6.5	8.4
HMVC - 17	3.340	12	6.102	1.496	4.803	3.386	0.197	0.197	6.8	8.6
HMVC - 18	3.527	12	6.299	1.496	5.000	3.583	0.197	0.197	7.4	9.0
HMVC - 19	3.730	12	6.496	1.496	5.236	3.780	0.197	0.197	7.7	9.7
HMVC - 20	3.918	12	6.693	1.496	5.433	3.976	0.236	0.197	8.1	10.0
HMVC - 22	4.325	12	7.087	1.496	5.866	4.370	0.236	0.197	8.8	12.5
HMVC - 24	4.716	12	7.480	1.496	6.260	4.764	0.236	0.197	9.5	11.7
HMVC - 26	5.106	12	7.874	1.496	6.693	5.157	0.236	0.197	10.1	12.5
HMVC - 28	5.497	12	8.268	1.496	7.087	5.551	0.276	0.197	10.7	13.4
HMVC - 30	5.888	12	8.661	1.535	7.480	5.945	0.276	0.197	11.6	14.5
HMVC - 32	6.284	8	9.252	1.575	8.110	6.339	0.276	0.236	13.3	17.0
HMVC - 34	6.659	8	9.645	1.614	8.465	6.732	0.276	0.236	14.7	18.5
HMVC - 36	7.066	8	10.039	1.615	8.858	7.126	0.276	0.236	16.0	20.0
HMVC - 38	7.472	8	10.630	1.653	9.409	7.520	0.315	0.276	17.8	23.1
HMVC - 40	7.847	8	11.024	1.693	9.882	7.913	0.315	0.276	19.4	25.1
HMVC - 44	8.628	8	12.008	1.732	10.748	8.740	0.315	0.354	22.3	29.5
HMVC - 48	9.442	6	12.992	1.811	11.654	9.528	0.354	0.394	25.6	35.9
HMVC - 52	10.192	6	13.976	1.850	12.559	10.315	0.354	0.433	29.1	41.8
HMVC - 56	11.004	6	14.961	1.929	13.425	11.102	0.354	0.472	32.7	48.4
HMVC - 60	11.785	6	15.945	2.008	14.331	11.890	0.394	0.551	36.6	56.3
HMVC - 64	12.562	6	16.929	2.087	15.236	12.677	0.394	0.551	40.8	65.1
HMVC - 68	13.334	5	17.717	2.087	16.063	13.465	0.394	0.551	44.0	71.5
HMVC - 72	14.170	5	18.701	2.205	16.969	14.252	0.394	0.590	48.5	81.4
HMVC - 76	14.957	5	19.685	2.283	17.795	15.039	0.433	0.630	52.1	90.2
HMVC - 80	15.745	5	20.669	2.362	18.701	15.827	0.433	0.669	56.9	101.2
HMVC - 84	16.532	5	21.457	2.401	19.606	16.614	0.433	0.669	62.0	110.9
HMVC - 88	17.319	5	22.244	2.441	20.433	17.402	0.472	0.669	65.9	121.0
HMVC - 92	18.107	5	23.228	2.520	21.299	18.189	0.472	0.669	69.8	134.2
HMVC - 96	18.894	5	24.094	2.559	22.165	18.976	0.472	0.748	75.2	143.0
HMVC - 100	19.682	5	25.000	2.598	23.031	19.764	0.472	0.748	80.6	157.3
HMVC - 106	20.867	4	26.378	2.716	24.291	20.945	0.512	0.827	87.1	176.0
HMVC - 112	21.923	4	27.756	2.795	25.591	22.126	0.512	0.866	94.9	198.0
HMVC - 120	23.623	4	29.528	2.874	27.283	23.701	0.512	0.905	104.5	220.0
HMVC - 126	24.804	4	30.709	2.913	28.583	24.882	0.551	0.905	113.0	242.0
HMVC - 134	26.379	4	32.480	2.992	30.236	26.457	0.551	0.945	123.2	270.6
HMVC - 142	27.961	3	34.252	3.071	31.969	28.031	0.590	0.984	135.9	301.4
HMVC - 150	29.536	3	36.024	3.110	33.661	29.606	0.590	0.984	150.4	330.0
HMVC - 160	31.504	3	38.189	3.150	35.748	31.575	0.630	0.984	161.2	380.6
HMVC - 170	33.473	3	40.157	3.268	37.874	33.543	0.630	1.024	177.6	418.0
HMVC - 180	35.441	3	42.126	3.386	39.960	35.511	0.669	1.181	192.2	462.0
HMVC - 190	37.410	3	44.291	3.386	42.087	37.480	0.669	1.181	210.2	523.6

HMVC - 10 through HMVC - 64 have American National Threads Class 3.

HMVC - 68 through HMVC - 190 have Acme General-Purpose Threads Class 3G.

INDEX

TIMKEN® SAF SPLIT-BLOCK HOUSED UNITS

222 Series (225, 222 Series SAF, SDAF)	D-37
223 Series (226, 223 Series SAF, SDAF)	D-39
230 Series (230K Series SAF, SDAF)	D-40
231 Series (231, 231K Series SDAF)	D-42
232 Series (232, 232K Series SDAF)	D-43
Engineering	D-3
Inch Accessories – Locknuts and Lockplates	D-104
Inch Accessories – Locknuts and Lockwashers	D-100
Inch Accessories – Pull-Type Sleeves	D-86
Inch Accessories – Push-Type Sleeves	D-96
Inch DUSTAC™ Shaft Seal	D-80
Inch HMVC Hydraulic Nuts	D-108
Inch Sine Bar Gages	D-81
Inch Straight Bore Mounting SAF222 and SAF223 Series	D-70
Inch Straight Bore Mounting SDAF222 and SDAF223 Series ..	D-72
Inch Straight Bore Mounting SDAF231 and SDAF232 Series ..	D-74
Inch Tapered Bore Mounting SAF225 and SAF226 Series	D-50
Inch Tapered Bore Mounting SAF230K, SDAF230K Series	D-64
Inch Tapered Bore Mounting SDAF225 and SDAF226 Series ..	D-60
Inch Tapered Bore Mounting SDAF231K and SDAF232K Series	D-68
Inch TTU Take-Up Units	D-78
Inch TU Take-Up Units	D-77
SAF Housed Unit Introduction	D-47
Timken® SAF Split-Block Housed Units	D-1



TIMKEN

The Timken team applies their know-how to improve the reliability and performance of machinery in diverse markets worldwide. The company designs, makes and markets high-performance steel as well as mechanical components, including bearings, gears, chain and related mechanical power transmission products and services.

www.timken.com



Stronger. Commitment. Stronger. Value. Stronger. Worldwide. Stronger. Together. | Stronger. By Design.

Price: USD \$75