

BHTS 330°

Extreme Temperature Bearings

ONLY FOR AUTOMATIC LUBRICATION



6000 SERIE

Designation	Bore (B)	Diam (D)	Width (W)	Speed, RPM	Static Load, kN at 330°C	Static Load, kN at 20°C
6000 BHTS 330°	10	26	8	282	1,35	1,96
6001 BHTS 330°	12	28	8	262	1,63	2,36
6002 BHTS 330°	15	32	9	242	1,97	2,85
6003 BHTS 330°	17	35	10	222	2,24	3,25
6004 BHTS 330°	20	42	12	200	3,45	5,00
6005 BHTS 330°	25	47	12	170	4,04	5,85
6006 BHTS 330°	30	55	13	130	5,52	8,00
6007 BHTS 330°	35	62	14	110	7,17	10,4
6008 BHTS 330°	40	68	15	100	8,14	11,8
6009 BHTS 330°	45	75	16	90	9,86	14,3
6010 BHTS 330°	50	80	16	85	10,76	15,6
6011 BHTS 330°	55	90	18	75	14,62	21,2
6012 BHTS 330°	60	95	18	70	16,00	23,2
6013 BHTS 330°	65	100	18	63	17,24	25,0
6014 BHTS 330°	70	110	20	60	21,72	31,5
6015 BHTS 330°	75	115	20	50	23,45	34,0
6016 BHTS 330°	80	125	22	50	27,58	40,0
6017 BHTS 330°	85	130	22	50	29,59	42,9
6018 BHTS 330°	90	140	24	50	34,41	49,9
6019 BHTS 330°	95	145	24	50	37,21	53,9
6020 BHTS 330°	100	150	24	50	37,21	53,9

6200 SERIE

Designation	Bore (B)	Diam (D)	Width (W)	Speed, RPM	Static Load, kN at 330°C	Static Load, kN at 20°C
6200 BHTS 330°	10	30	9	262	1,79	2,60
6201 BHTS 330°	12	32	10	242	2,14	3,10
6202 BHTS 330°	15	35	11	180	2,59	3,75
6203 BHTS 330°	17	40	12	175	3,28	4,75
6204 BHTS 330°	20	47	14	150	4,52	6,55
6205 BHTS 330°	25	52	15	140	5,52	8,00
6206 BHTS 330°	30	62	16	110	7,72	11,2
6207 BHTS 330°	35	72	17	100	10,55	15,3
6208 BHTS 330°	40	80	18	85	12,41	18,0
6209 BHTS 330°	45	85	19	80	14,06	20,4
6210 BHTS 330°	50	90	20	75	16,55	24,0
6211 BHTS 330°	55	100	21	67	20,00	29,0
6212 BHTS 330°	60	110	22	60	24,83	36,0
6213 BHTS 330°	65	120	23	53	28,62	41,5
6214 BHTS 330°	70	125	24	50	30,35	44,0
6215 BHTS 330°	75	130	25	50	33,79	49,0
6216 BHTS 330°	80	140	26	50	37,93	55,0
6217 BHTS 330°	85	150	28	50	44,14	64,0
6218 BHTS 330°	90	160	30	50	50,69	73,5
6219 BHTS 330°	95	170	32	50	56,21	81,5
6220 BHTS 330°	100	180	34	50	64,14	93,0

6300 SERIE

Designation	Bore (B)	Diam (D)	Width (W)	Speed, RPM	Static Load, kN at 330°C	Static Load, kN at 20°C
6300 BHTS 330°	10	35	11	220	2,38	3,45
6301 BHTS 330°	12	37	12	200	2,86	4,15
6302 BHTS 330°	15	42	13	180	3,72	5,40
6303 BHTS 330°	17	47	14	160	4,52	6,55
6304 BHTS 330°	20	52	15	140	5,86	8,50
6305 BHTS 330°	25	62	17	110	7,86	11,4
6306 BHTS 330°	30	72	19	95	11,24	16,3
6307 BHTS 330°	35	80	21	85	13,10	19,0
6308 BHTS 330°	40	90	23	75	17,24	25,0
6309 BHTS 330°	45	100	25	67	22,06	32,0
6310 BHTS 330°	50	110	27	60	26,21	38,0
6311 BHTS 330°	55	120	29	53	32,76	47,5
6312 BHTS 330°	60	130	31	50	35,86	52,0
6313 BHTS 330°	65	140	33	50	41,38	60,0
6314 BHTS 330°	70	150	35	50	46,90	68,0
6315 BHTS 330°	75	160	37	50	52,76	76,5
6316 BHTS 330°	80	170	39	50	59,66	86,5
6317 BHTS 330°	85	180	41	50	66,55	96,5
6318 BHTS 330°	90	190	43	50	74,48	108
6319 BHTS 330°	95	200	45	50	81,38	118
6320 BHTS 330°	100	215	47	50	96,55	140

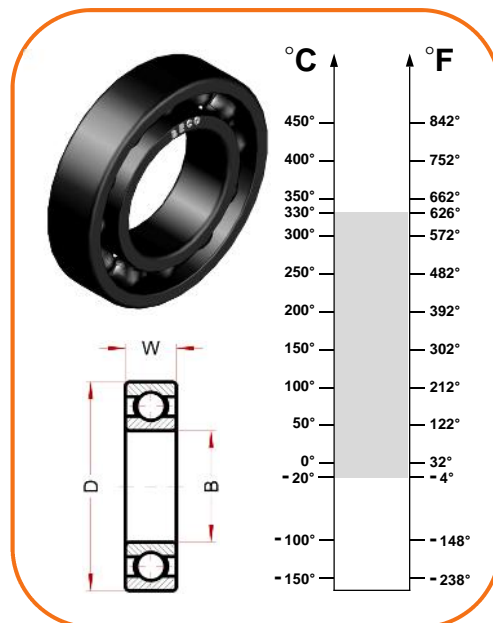

Technical characteristics:

- Bearing material: steel AISI 52100 (Chrome) stabilized to the application
- Treatment of manganese phosphate coating on all steel parts of the bearing
- Radial Clearance 4xC5
- Bearing running open
- Lubricated with molybdenum disulphide grease*
- **Need additional lubrication with oil for High Temperature**

Note:

*Bearing, lubricated with molybdenum grease, requires additional dropping of oil for high temperature. Absence of additional periodical lubrication causes fast oxidation, locking of the bearing and strong reduction of lifetime. Its use is suggested only in existing applications with automatic oil dropping system.



12100 Cuneo - Italy

phone: 0039 0171 66883

fax: 0039 0171 648913

www.becoitalia.it