



OVERRUNNING CLUTCHES AND BACKSTOPS

OVERRUNNING CLUTCHES AND BACKSTOPS

Product Catalogue // 2008

Combined bearing/freewheel

20



IMPRINT

1st Edition 11.2007
PART-NO. ST1354r-en

Published by:
© Stieber GmbH
Hatschekstraße 36
69126 Heidelberg
Germany

This document must not be re-printed, duplicated or translated in full or in part without our prior written consent and without reference to the source of the material.

All content including pictures and diagrams is subject to alteration. We accept no liability.

Layout and Production:
Hela Werbung GmbH
www.hela.com

| | |
|------------|----|
| CSK | 20 |
| CSK..2RS | 20 |
| CSK..P | 22 |
| CSK..PP | 22 |
| CSK..P-2RS | 22 |
| ASK | 24 |
| GFK | 26 |

| | | | |
|--------------------------------------|----|-----------------------------|----|
| Stieber – Competence is our strength | 4 | Mounting instructions | 16 |
| The principle | 6 | Lubrication and maintenance | 18 |
| Design | 7 | Products | 20 |
| Selection | 10 | Special design | 90 |
| Selection procedure | 11 | Alphabetical list | 91 |
| Selection table | 14 | Product names old new | 91 |

Built-in freewheels

28



| | |
|----------|----|
| ▶ KI | 28 |
| AS | 30 |
| ASNU | 32 |
| AE | 34 |
| AA | 36 |
| NF | 38 |
| S200 | 40 |
| DC | 42 |
| DC-Races | 44 |
| NFR | 46 |

Self-contained freewheels

48



| | |
|----------------|----|
| ▶ RSBW | 48 |
| AV | 50 |
| AL | 52 |
| ALP | 52 |
| AL..F2D2 | 54 |
| AL..F4D2 | 54 |
| ALP.. F7D7 | 56 |
| ALMP..F7D7 | 56 |
| AL..KEED2 | 58 |
| AL..KMSD2 | 60 |
| GFR | 62 |
| GFRN | 62 |
| GFR..F1F2 | 64 |
| GFR..F2F7 | 64 |
| GFRN..F5F6 | 64 |
| GFR..F2F3 | 66 |
| GFR..F3F4 | 66 |
| SMZ | 68 |
| FSO 300-700 | 70 |
| FSO-GR 300-700 | 70 |
| HPI 300-700 | 70 |
| FS 750-1027 | 72 |
| FSO 750-1027 | 72 |
| HPI 750-1027 | 72 |
| AL..G | 74 |

Centrifugal lift-off sprags freewheels

76



| | |
|-------------------------|----|
| ▶ Built-in freewheels | |
| RSCI 20-130 | 76 |
| RSCI 180-300 | 78 |
| Self-contained clutches | |
| RIZ-RINZ | 80 |
| RIZ..G1G2 | 82 |
| RIZ.. G2G7 | 82 |
| RINZ..G5G5 | 82 |
| RIZ..G2G3 | 84 |
| RIZ..G3G4 | 84 |
| RIZ..ELG2 | 86 |
| RIZ..ESG2 | 88 |



STIEBER: COMPETENCE IS OUR STRENGTH.



INNOVATIVE: DEVELOPEMENT

Throughout its long history Stieber has been familiar with all types of freewheel designs such as roller and sprag variants and consistently led the way in developing new designs and technologies.

We have an unmatched ability in the field of over-running clutches, built on the long experience of our team of qualified engineers and always seeking the best answers in design and manufacture. Alongside a continuous programme of product development unique solutions have been found over the years including:

- Encased overrunning clutches lubricated and cooled by internal oil circulation without the need for a pump.
- Overrunning clutches that may be disengaged either manually or pneumatically.
- Irreversible locks. A novel adaptation of the freewheel principle.

and more than 3,000 special designs developed for specific customer requirements. We can supply anything from 0.8 to 1.7 million Nm so you can be sure of finding the best solution, whatever the application.

ACCURATE: PRODUCTION

Standard products and customer-specific items are produced according to the latest techniques and quality requirements in our two manufacturing plants. Our skilled and experienced workforce take every care to deliver to you a reliable, quality product.

Our commitment to continuous improvement ensures that our systems and processes are constantly under review. Over the past few years this has led to a 30% time saving in manufacture, for example.

The assembly and warehouse departments control stock and material flow using a Kanban system to ensure the correct availability of standard parts and on-time delivery to you the customer.

If you buy your freewheels from Stieber you can be sure of the best in quality and reliability for you and your customers—guaranteed.



STIEBER

Stieber was founded in Munich in 1937 and is now a medium-sized company employing 140 people at its locations in Heidelberg and Garching near Munich.

Our core business activity is the design and production of drive elements for mechanical engineering systems. Our major strength is the development and production of overrunning clutches and backstops, which transmit torque by means of friction.

Stieber can reflect on numerous innovative developments during the course of the company's history innovations that have made it the European market leader. Stieber proved its technical ability once again during the development and design of the largest backstop in the world, for example. This and other backstops are being successfully used even under the toughest of conditions.

Stieber, part of the Altra Industrial Motion Group is – together with its sister companies Formsprag and Marland in the USA – the world's market leader for overrunning clutches and backstops.

Our extensive world-wide service network including more than 1000 stocking distributors and technical centres ensures we are always close to the customers.

Our company philosophy is total customer satisfaction. To achieve this, our processes undergo continual refinement.

Stieber has been certified according to DIN EN ISO 9001 since 1997 and according to ISO 14001 (environment management system) since the year 2000. In addition, an internal monitoring process ensures that quality, timeliness and costs are always to the fore.

TRADEMARK: QUALITY

Total quality is assured both by meeting prescribed product performance specifications and thanks to the reliability of manufacturing methods and process workflows including integrated tests. The key technical data of Stieber products are either calculated using FVA* methods and/or verified on our test benches.

We have test machines with a torque capacity of up to 700.000 Nm. During idling, units with a bore up to 600 mm can be tested at speeds of up to 1.500 rpm. The modern equipment in our quality department allows

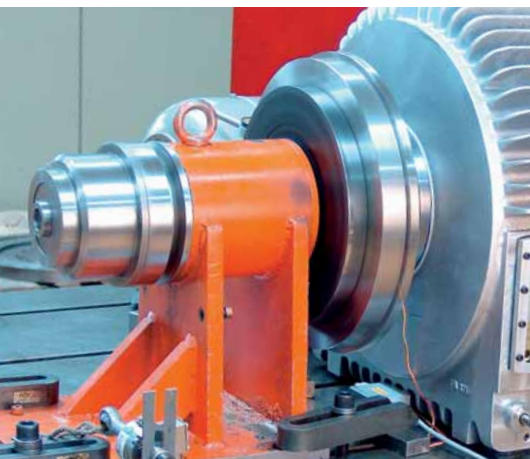

us to carry out all the necessary tests ourselves, such as those for the nuclear power industry, for example. Thanks to this, Stieber has been certified by Framatome/Siemens among others in compliance with KT 1401."

*1) Power transmission Research Association

THE PRINCIPLE: THE RIGHT ANSWER – EVERY TIME.

1

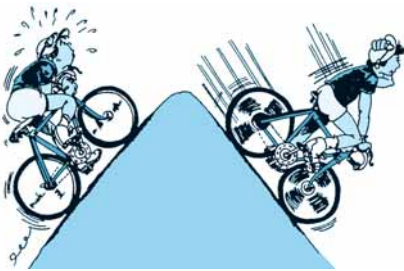

1 Overrunning clutch

The freewheel disengages automatically when the driven member rotates faster than the driving member.

2 Indexing clutch

The freewheel allows the conversion of reciprocating motion into rotational movement.

3 Backstop

The freewheel allows rotation in one direction only. It overruns continuously during operation. The freewheel prevents reverse rotation if the drive is disconnected.

2

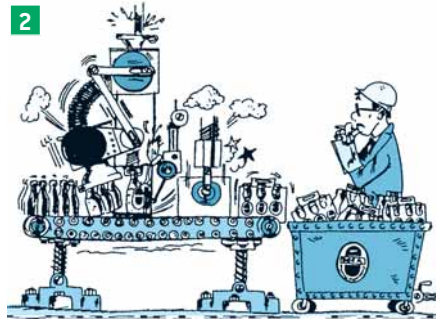

3



Overrunning clutches are directional couplings, which means they are engaged and disengaged automatically, depending on the relative direction of rotation of the driving and driven sides. Practical applications of this principle:

1 Overrunning clutch

for multiple-machine drives or to separate the inertia of masses of a driven machine from the driving machine after it has been switched off.

2 Indexing clutch

which turns a shaft step by step, thus achieving indexed material feed or a variable speed.

3 Backstop

to prevent a machine shaft turning backwards. In this case the overrunning clutch acts as a brake.

BASIC FORMS: ALWAYS A PERFECT SOLUTION.

To achieve the functions described overleaf, so-called locking elements are positioned between an outer and an inner race which effect engaging and disengaging. These locking elements are of two basic designs:

Roller clutch

Mainly used as overrunning and indexing clutches.

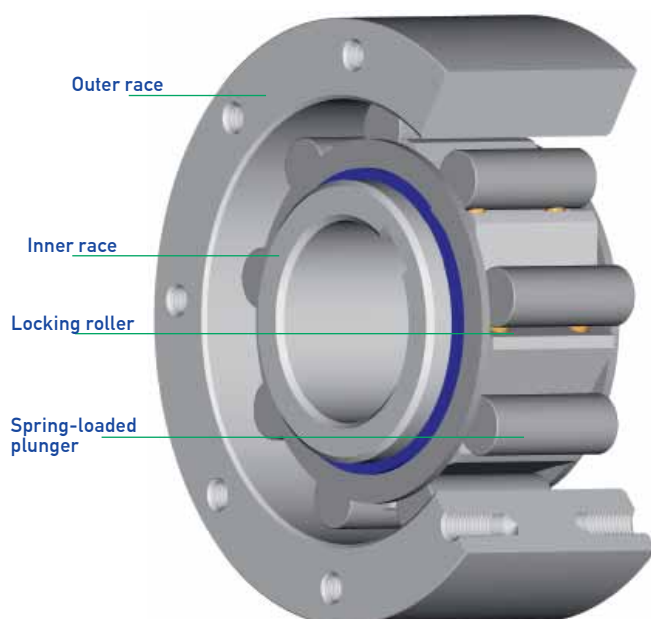

- Rugged
 - Versatile
 - High indexing accuracy
 - High performance
- overrunning clutch

Sprag clutch

Most suitable as backstops, and mostly the contact-free versions.

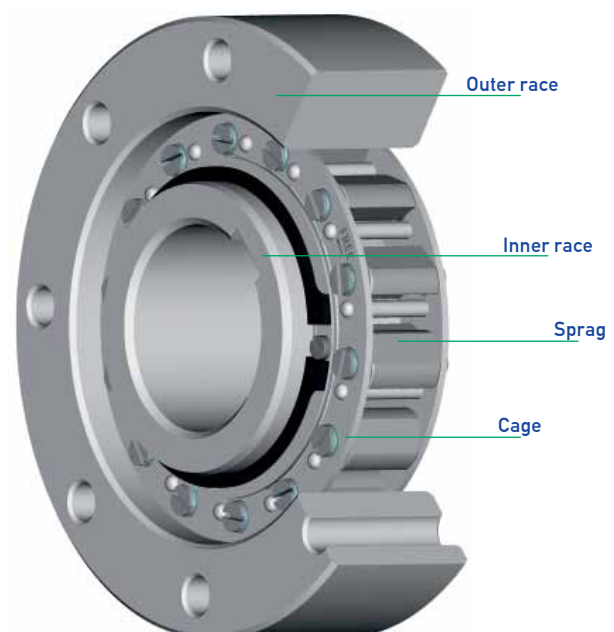

- High overrunning speed
- High torque capacity
- High eccentricity tolerances
- Accepts any lubricant

We offer our freewheels in different versions either without bearing support (built-in) or with bearing support (self-contained). (» see selection table page 14)

DESIGN: MANY VERSIONS – ONE QUALITY.

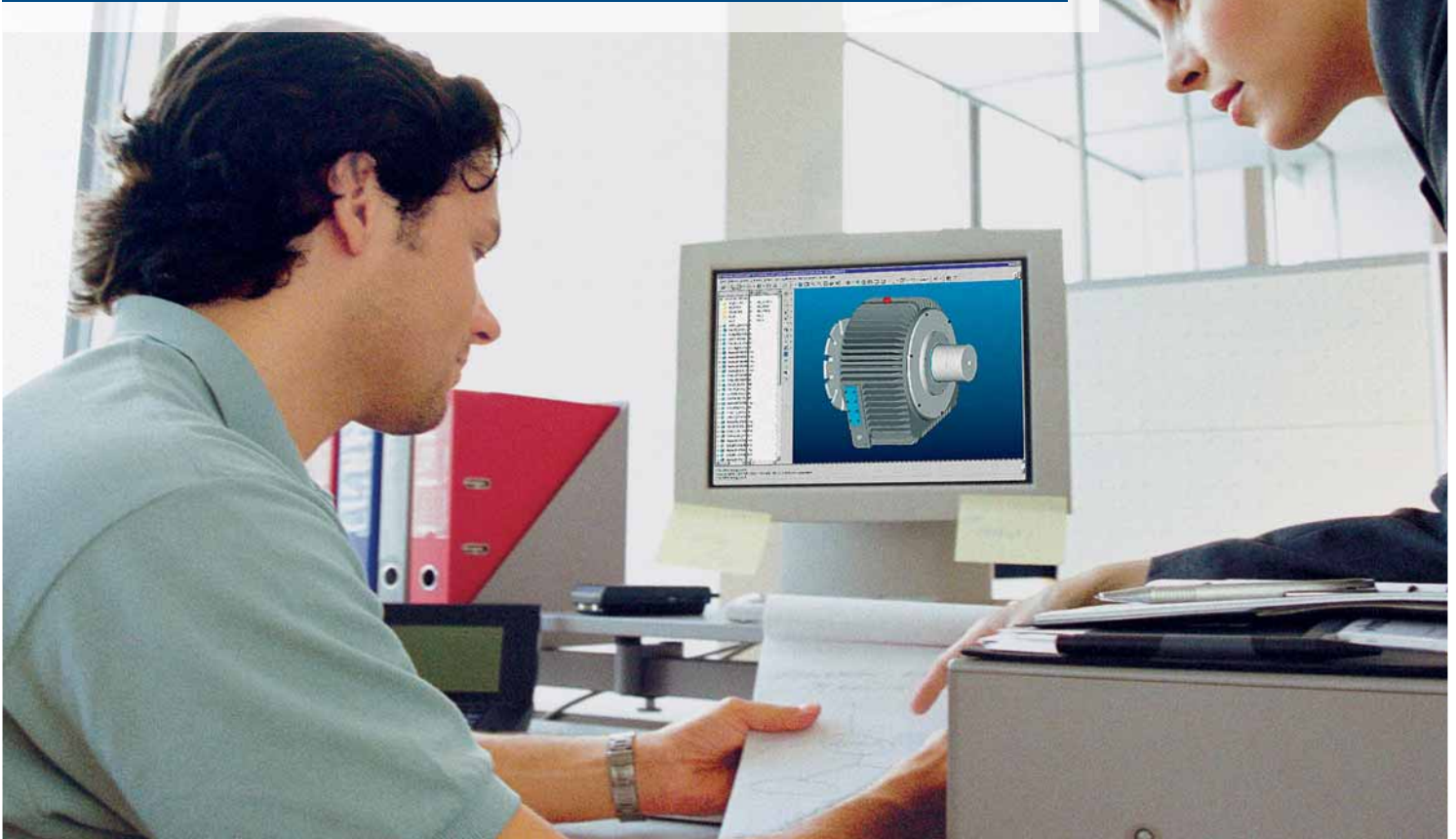

ROLLER FREEWHEELS

These freewheels feature a cylindrical outer race and an inner consisting of ramps on which rollers are located. Springs and plungers ensure a permanent contact between the different elements for an instant torque transmission. This rugged, reliable versatile design can be used as an overrunning clutch, indexing clutch or backstop.

Note: the highest overrunning speed is possible if the outer race is overrunning. For this reason it is particularly adapted to high speed overrunning clutch application for dual drivers.

This design is recommended for use as an indexing clutch. To maximise accuracy, specify »V« type, fitted with stronger springs.



SPRAG FREEWHEELS

In this type of freewheel, the two races are cylindrical. The sprags, fitted in a cage, feature an active profile that ensures engagement or disengagement according to the relative motion of the races.

It is possible to adapt the design of sprags and cage to get significantly different characteristics from one model to another. For example, models which have permanent contact or are contact free during overrunning, are available.

1 Outer race 2 Sprag 3 Inner race

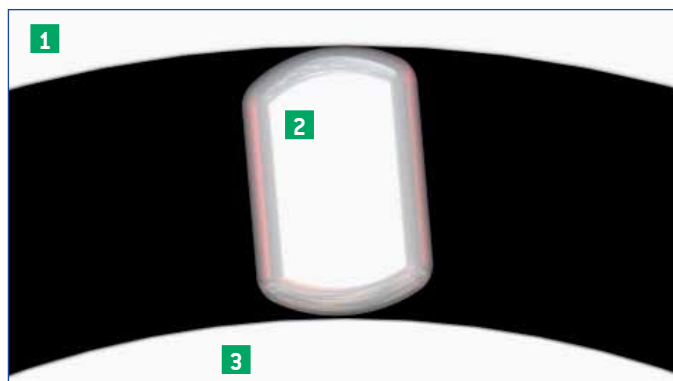

1 Outer race 2 Cage 3 Spring 4 Sprag 5 Inner race

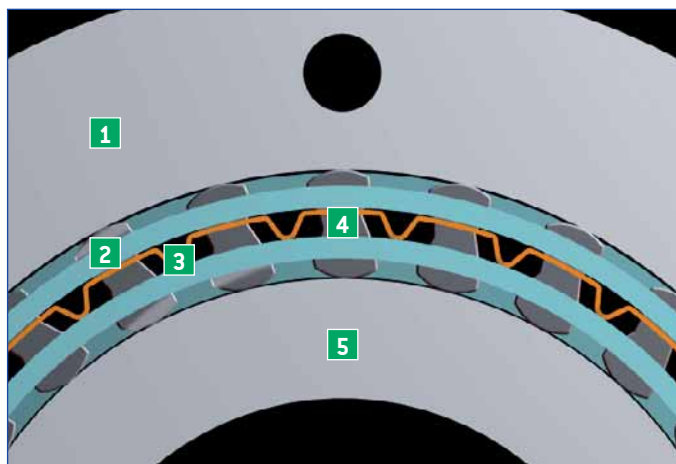

DC DESIGN

This model features a large number of sprags controlled by two concentric cages. The transmitted torque is high compared to the required space. Sprags are synchronised by the double cage design, and individually energized by a special spring.

In addition to the DC series offered in this catalogue, the CSK, GFK, and RSBW ranges use a similar principle.

Torque transmission

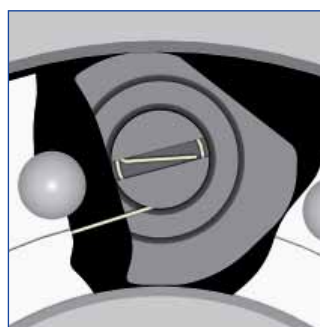

Overrunning

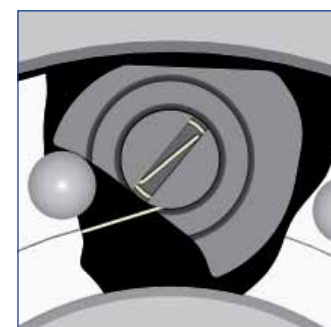

RSCI, RIZ DESIGN

Sprags in this design, are fitted into a cage connected to the overrunning member. The sprag configuration is such that its centre of gravity is offset to its rotation axis.

Centrifugal force creates a lift off moment against an engaging spring. When the centrifugal force moment is greater than that of the spring, the sprag tilts over to a contact free position.

The sprag height and its active profile length allow this type of freewheel to accept significant eccentricity tolerances and to work with all the current lubricants used in power transmissions.

STIEBER SOLUTIONS: ALWAYS THE RIGHT CHOICE.

Unit selection is initially determined by the type of application:
OC Overrunning clutch, IC Indexing clutch, BS Backstop.

Different technical information is required for each one of them. Mounting details and lubrication requirements finally determine the unit selected. The information required for each type of application is as follows:

OC

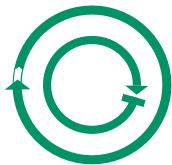

IC

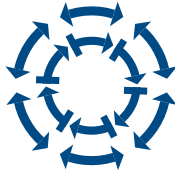

BS

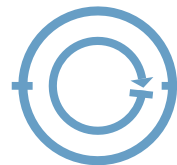

OVERRUNNING CLUTCH

- Type of motor
- $Nm_{start}/Nm_{nominal}$ of E-motors
- Internal combustion engines, please consult Stieber
- Nominal driving torque
- Range of driving speed
- Inertia „J“ of the driven masses
- Range of overrunning speed
- Number of start during service life
- Shaft diameter

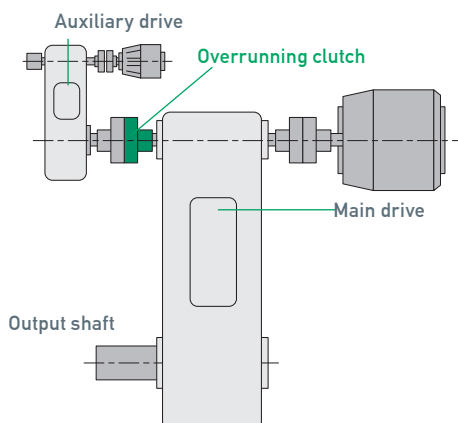

INDEXING CLUTCH

- Number of cycles/min
- Index angle
- Nominal torque
- Inertia „J“ of the driven masses
- Accelerations of the driving member
- Number of indexes during service life
- Shaft diameter

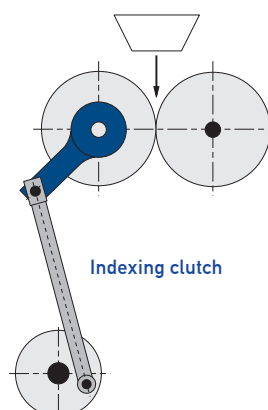

BACKSTOP

- Static reverse torque
- Maximum dynamic reverse torque. due to elasticity of the locked parts (elastic belts, shafts more than 3 meters long)
- Range of overrunning speed
- Number of torque applications during service life
- Shaft diameter

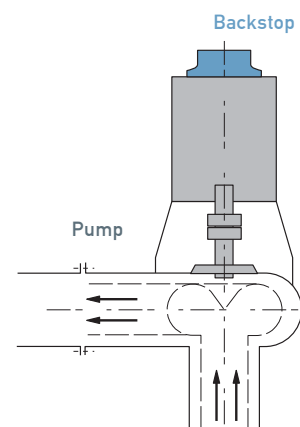

THE SELECTION PROCEDURE: WE ADVISE, YOU DECIDE.

If we have the data described on the previous page, Stieber can make the most accurate selection.

If all of the information is not available, or if you want to make a selection yourself, the following service factor procedure may be used.

Note: The following method and the service factors used are only a guide based on experience and cannot cover all situations. We cannot accept responsibility for incorrect selection resulting from the use of these tables.

STEP 1 TORQUE SELECTION

The first step is to calculate the catalogue torque (T_{KN}) of the unit to be chosen. This torque is derived from the application nominal torque (T_{appl}) multiplied by a service factor (S.F.) depending on the function of the freewheel and working conditions.

Nominal torque of the application::

$$T_{appl} \text{ (Nm)} = \frac{9550 \times P \text{ (kW)}}{n \text{ (min}^{-1}\text{)}}$$

The unit catalogue torque will be:

$$T_{KN} \geq T_{appl} \times \text{S.F.}$$

S.F. (service factor) can be read from the selection tables on page 12.

Note: All the units shown in this catalogue can support a maximum torque equal to 2 times the catalogue torque T_{KN} indicated in the respective data tables.

The following curve may be used as a guide to determine the relationship between torque transmitted and the number of cycles (applications of this torque) the unit would withstand in its life time. Average values are shown.

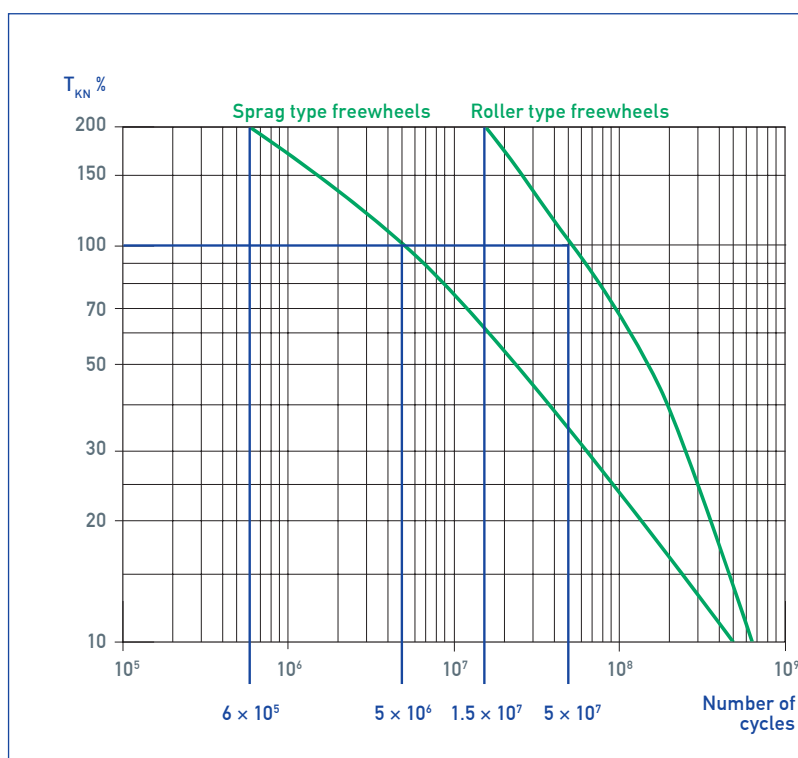

SERVICE FACTORS.

APPLICATION INDEXING

| Indexing speed | Type of freewheel | |
|---|-------------------|------------|
| | Roller type | Sprag type |
| Over 150 strokes/min | 3.0 | 4.0 |
| Angle > 90° Over 100 strokes/min | 2.5 | 4.0 |
| Angle > 90° Less than 100 strokes/min | 2.0 | 3.5 |

APPLICATION BACKSTOP

| Driving machine | Driven machine | | | | |
|--|---|---|------|----------------|-------------------|
| | Elastic conveyor belts with risk of jam | Pump drives with more than 5 metres shaft | Fans | Other machines | |
| | | | | No overloads | Dynamic overloads |
| Motors with hydraulic couplings | 1.3 | 1.6 | 0.5 | 1.0 | 1.5 |
| Asynchronous motors with direct start ¹ | 1.6 | 1.6 | 0.5 | 1.0 | 1.5 |
| Steam or gas turbine | — | 1.6 | 0.5 | 1.0 | 1.5 |
| Internal combustion engine | 1.6 | 1.6 | 0.5 | 1.0 | 1.5 |

1) These values do not cover a motor start in the wrong direction.

APPLICATION OVERRUNNING

| Driving machine | Working conditions | | | |
|---|--|---|---|---|
| | Starting torque not higher than nominal Smooth drive. | Starting torque up to 2 times running torque. Moderate load variations. | Starting torque 2 to 3 times running torque. Load variations. | High starting torque. High load torque variations. |
| DC - motor. AC - motor with soft start or hydraulic coupling | 1.3 | 1.5 | 1.8 | — |
| Asynchronous motor with direct start | Speed reduction between motor & freewheel < 4 | — | 3.0 | 4.0 |
| | Speed reduction between motor & freewheel > 4 | — | 1.8 | 2.3 |
| Steam or gas turbine | 1.3 | 1.5 | — | — |
| Internal combustion engine | Petrol 4 cyl.or Diesel < 6 cyl. | 4.0 | 5.0 | Contact Stieber. |
| | Diesel ≥ 6 cyl. | 5.0 | 6.0 | Contact Stieber. |



STEP 2 MODEL SELECTION

When the catalogue torque is known, the model will be selected from the following criteria:

- Built-in or self-contained design
- Driving and overrunning speed limits
- Dimensions
- Lubrication and maintenance

Please refer to the selection table page 14 for a guide to selection. The product range is presented in this order:

SELF-CONTAINED BALL BEARING UNITS (CSK RANGE)

General purpose, economical units for light applications. Grease lubricated, maintenance free. With or without key(s) mounting to shaft and housing.

BUILT-IN UNITS

roller types with inner and outer races (A-series) or only a cage (DC sprag series). Bearing support, lubrication and maintenance must be provided.

SELF-CONTAINED UNITS

- Low speed, grease lubricated, maintenance free (RSBW, AV series)
- Medium overrunning speed inner race. High overrunning speed outer race. Roller types, oil lubricated. (AL, GFR series).

- High overrunning speed inner race. Medium overrunning speed outer race. Sprag types, oil or grease lubricated (SMZ, FS, FSO series).
- High speed, high power, for continuous duty encased overrunning clutches (AL..G series).

CENTRIFUGAL LIFT OFF SPRAG TYPES















Special overrunning clutches and backstops contact free during overrunning. Please be aware of the speeds permissible in driving and overrunning modes.

- Built-in units: Low lubrication requirement. Accept a large range of lubricants (RSCI series).
- Self-contained units: Grease lubricated, long life and maintenance free (RIZ series).

SELECTION TABLE

| | Applications groups | Type of support |    | | | Bore range-diameter | Torque range |
|---|---|--------------------|--|-------------|-------|---------------------|--------------|
| | | | OC | IC | BS | | |
| CSK..2RS CSK/CSK..P ASK GFK | Integral bearing/ freewheel based on series 62, 60 and 59 | Bearing support | ○ | ○ | ○ | 8–40 | 2.5–325 |
| | | | ● | ● | ● | 12–40 | 2.5–325 |
| | | | ○ | ○ | ○ | 12–40 | 16.9–325 |
| | | | ● | ● | ● | 20–30 | 50–138 |
| | | | ○ | ○ | ○ | 40–60 | 72–250 |
| | | | ● | ● | ● | 20–50 | 51–460 |
| KI AS (NSS) ASNU (NFS) AE AA NF S200 DC DC-Races NFR | Built-in freewheels: Must be integrated in a housing that provides bearing support and lubrication. Low to medium torque and speeds. | No bearing support | ○ | ○ | ○ | 4–10 | 0.8–2.9 |
| | | | ● | ● | ● | 6–80 | 2.1–1 063 |
| | | | ○ | ○ | ○ | 8–200 | 12–44 500 |
| | | | ● | ● | ● | 12–70 | 17–5813 |
| | | | ○ | ○ | ○ | 12–70 | 17–5813 |
| | | | ● | ● | ● | 8–150 | 20–44 375 |
| | | | ○ | ○ | ○ | 16–56 | 45–850 |
| | | | ● | ● | ● | 10–70 | 63–4 875 |
| | | | ○ | ○ | ○ | 10–70 | |
| | | ● | ● | ● | 8–130 | 20–34 750 | |
| RSBW AV AL/ALP AL..F2D2/F4D2 ALP../ALMP..F7D7 AL..KEED2 AL..KMSD2 GFR/GFRN GFR..F1F2 GFR..F2F7 GFRN..F5F6 GFR..F2F3 GFR..F3F4 SMZ FSO/FSO-GR/HPI FS/FSO/HPI AL..G | Self-contained clutches: Sealed, with integral lubrication. From small to high torques, low to max speeds. Applications in all types of industry. | Bearing support | | | ○ | 25–90 | 375–4 875 |
| | | | | ● | ● | 20–120 | 265–11 000 |
| | | | ○ | ○ | ○ | 12–250 | 55–287 500 |
| | | | ● | ● | ● | 12–250 | 55–287 500 |
| | | | ○ | ○ | ○ | 12–250 | 55–287 500 |
| | | | ● | ● | ● | 12–250 | 55–287 500 |
| | | | ○ | ○ | ○ | 12–250 | 55–250 000 |
| | | | ● | ● | ● | 12–120 | 50–20 000 |
| | | | ○ | ○ | ○ | 12–150 | 55–70 000 |
| | | | ● | ● | ● | 12–150 | 55–70 000 |
| | | | ○ | ○ | ○ | 12–150 | 55–70 000 |
| | | | | | ● | 12–150 | 55–70 000 |
| | | | | | ○ | 12–150 | 55–70 000 |
| | | | ● | ● | ● | 20–70 | 300–4 300 |
| | | | ○ | ○ | ○ | 12–80 | 379–6 900 |
| ● | ● | ● | 57–175 | 9660–36 612 | | | |
| | | ○ | 12–150 | 288–45 000 | | | |
| RSCI 20-130 RSCI 180-300 RIZ / RINZ RIZ..G1G2/..G2G7 RINZ..G5G5 RIZ..G2G2/..G3G4 RIZ..ELG2 RIZ..ESG2 | Centrifugally lift off sprags: Wear free above a given speed. High speeds with little lubrication demand. Specifically designed for: gear reducers, motors, pumps, ventilators, turbines. | No bearing support | ○ | | ○ | 100–240 | 7250–38 250 |
| | | | ● | | ● | 20–240 | 212–100 000 |
| | | Bearing support | ○ | | ○ | 30–130 | 313–16 875 |
| | | | ● | | ● | 30–130 | 313–16 875 |
| | | | ○ | | ○ | 30–130 | 313–16 875 |
| | | | | | ● | 30–130 | 313–16 875 |
| | | | | | ○ | 30–130 | 313–16 875 |
| | | | ● | | | 30–130 | 313–16 875 |
| | | | ○ | | | 30–130 | 80–16 000 |

OC = Overrunning clutch | IC = Indexing clutch | BS = Backstop | ○ = Special working conditions

| Overrunning Speed inner race | Overrunning Speed outer race | Lubrication | Types | Page | |
|--|---|---|---|--|--|
|  |  |  | CSK CSK..2RS CSK..P. CSK..PP CSK..P-2RS ASK GFK | 20 20 22 22 24 26 | |
|  |  |  | KI AS (NSS) ASNU (NFS) AE AA NF | 28 30 32 34 36 38 | |
|  |  | | S200 DC DC Ringe | 40 42 44 | |
|  |  | | NFR | 46 | |
|  | not possible | |  | RSBW AV | 48 50 |
|  |  |  | AL/ALP AL..F2D2 AL..F4D2 ALP..F7D7 AL..KEED2 AL..KMSD2 GFR-GFRN GFR..F1F2/F2F7 GFRN..F5F6 | 52 54 54 56 58 60 62 64 64 | |
| | not possible | | GFR..F2F3 GFR..F3F4 | 66 66 | |
|  |  | |   | SMZ FSO 300-700 FSO 750-1027 | 68 70 72 |
| not possible |  | |  | AL..G | 74 |
|  | not possible | |   | RSCI 20-130 RSCI 180-300 | 76 78 |
|  | not possible | |  | RIZ-RINZ RIZ..G1G2/G2G7 RINZ..G5G5 RIZ..G2G3 RIZ..G3G4 RIZ..ELG2 RIZ..ESG2 | 80 82 82 84 84 86 88 |

 = high speed |  = middle speed |  = low speed

MOUNTING INSTRUCTIONS: SO THAT IT FITS.

KEY ASSEMBLIES

For all freewheel inner races connected to shaft by a key, our standard bore tolerance is H7, with keyway to JS10.

We recommend a shaft tolerance of h6 or j6. For maximum indexing accuracy, adjusted keys should be machined to give no clearance.

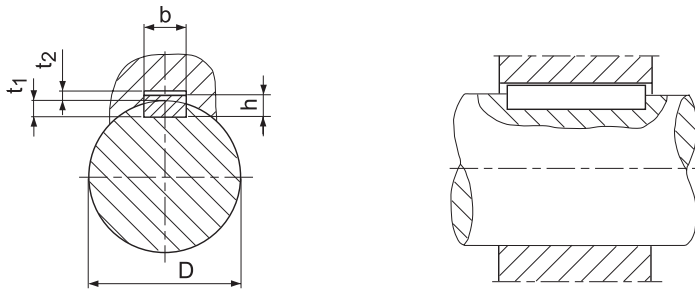

| Bore size | DIN 6885* Sheet 1 | | | | DIN 6885* Sheet 3 | | | |
|-----------|---------------------|----|----------------|----------------|---------------------|----|----------------|----------------|
| | b ^{JS10} | h | t ₁ | t ₂ | b ^{JS10} | h | t ₁ | t ₂ |
| > 6–8 | 2 ± 0.020 | 2 | 1.2 + 0.1 | 1 + 0.3 | | | | |
| > 8–10 | 3 ± 0.020 | 3 | 1.8 + 0.1 | 1.4 + 0.3 | | | | |
| > 10–12 | 4 ± 0.024 | 4 | 2.5 + 0.1 | 1.8 + 0.3 | | | | |
| > 12–17 | 5 ± 0.024 | 5 | 3 + 0.1 | 2.3 + 0.3 | 5 ± 0.024 | 3 | 1.9 + 0.1 | 1.2 + 0.3 |
| > 17–22 | 6 ± 0.024 | 6 | 3.5 + 0.1 | 2.8 + 0.3 | 6 ± 0.024 | 4 | 2.5 + 0.1 | 1.6 + 0.3 |
| > 22–30 | 8 ± 0.029 | 7 | 4 + 0.2 | 3.3 + 0.4 | 8 ± 0.029 | 5 | 3.1 + 0.1 | 2 + 0.3 |
| > 30–38 | 10 ± 0.029 | 8 | 5 + 0.2 | 3.3 + 0.4 | 10 ± 0.029 | 6 | 3.7 + 0.2 | 2.4 + 0.3 |
| > 38–44 | 12 ± 0.035 | 8 | 5 + 0.2 | 3.3 + 0.4 | 12 ± 0.035 | 6 | 3.9 + 0.2 | 2.2 + 0.3 |
| > 44–50 | 14 ± 0.035 | 9 | 5.5 + 0.2 | 3.8 + 0.4 | 14 ± 0.035 | 6 | 4 + 0.2 | 2.1 + 0.3 |
| > 50–58 | 16 ± 0.035 | 10 | 6 + 0.2 | 4.3 + 0.4 | 16 ± 0.035 | 7 | 4.7 + 0.2 | 2.4 + 0.3 |
| > 58–65 | 18 ± 0.035 | 11 | 7 + 0.2 | 4.4 + 0.4 | 18 ± 0.035 | 7 | 4.8 + 0.2 | 2.3 + 0.3 |
| > 65–75 | 20 ± 0.042 | 12 | 7.5 + 0.2 | 4.9 + 0.4 | 20 ± 0.042 | 8 | 5.4 + 0.2 | 2.7 + 0.3 |
| > 75–85 | 22 ± 0.042 | 14 | 9 + 0.2 | 5.4 + 0.4 | 22 ± 0.042 | 9 | 6 + 0.2 | 3.1 + 0.4 |
| > 85–95 | 25 ± 0.042 | 14 | 9 + 0.2 | 5.4 + 0.4 | 25 ± 0.042 | 9 | 6.2 + 0.2 | 2.9 + 0.4 |
| > 95–110 | 28 ± 0.042 | 16 | 10 + 0.2 | 6.4 + 0.4 | 28 ± 0.042 | 10 | 6.9 + 0.2 | 3.2 + 0.4 |
| > 110–130 | 32 ± 0.050 | 18 | 11 + 0.3 | 7.4 + 0.4 | 32 ± 0.050 | 11 | 7.6 + 0.2 | 3.5 + 0.4 |
| > 130–150 | 36 ± 0.050 | 20 | 12 + 0.3 | 8.4 + 0.4 | 36 ± 0.050 | 12 | 8.3 + 0.2 | 3.8 + 0.4 |

*1) Keyway tolerances for hardened parts are not given in DIN6885.



PRESS FIT ASSEMBLIES

Shaft and bore tolerances are specified on the pages for each type where press fitting is appropriate.

As with standard bearings, suitable tooling must be used for press fitting such that no axial load is transmitted through the inner part of the freewheel during assembly.



BOLT ASSEMBLIES

In freewheel technology torque is often transmitted through bolts. Experience has shown that it is a practical and reliable way since freewheels transmit torque in only one direction.

Bolt quality and tightening torques to use are as follows:

| Thread | Strength standard | | | |
|--------|-------------------|------|------|------|
| | 8.8 | | 10.9 | |
| | Type | [Nm] | Type | [Nm] |
| M5 | | 6 | | 8 |
| M6 | | 10 | AA | 14 |
| M8 | | 25 | AL | 34 |
| M10 | RSCI | 48 | FSO | 68 |
| M12 | | 84 | GFR | 118 |
| M16 | | 206 | HPI | 290 |
| M20 | | 402 | RIZ | 550 |
| M24 | | 696 | | 950 |
| M30 | | 1420 | | 1900 |

RUN-OUT

Permitted run-out tolerances for the mounting of non self supported roller freewheels AA, AE, AS, ASNU, KI and NF (» see table on the right).

In order to maintain these limits, ball bearings with standard clearance must be installed adjacent to the freewheel. The permitted run-out for sprag type freewheels DC, RSCI and S200 are given in their respective tables.

| Bores-diameter [mm] | AA, AE, AS, ASNU, KI, NF | |
|---------------------|--------------------------|----------------|
| | Runout TIR | Squareness TIR |
| 4–8 | 0.020 | 0.02 |
| 10–17 | 0.035 | 0.03 |
| 20–50 | 0.060 | 0.03 |
| 55–100 | 0.100 | 0.03 |
| 110–150 | 0.160 | 0.03 |

LUBRICATION AND MAINTENANCE: NOW LET'S LOOK AFTER IT.

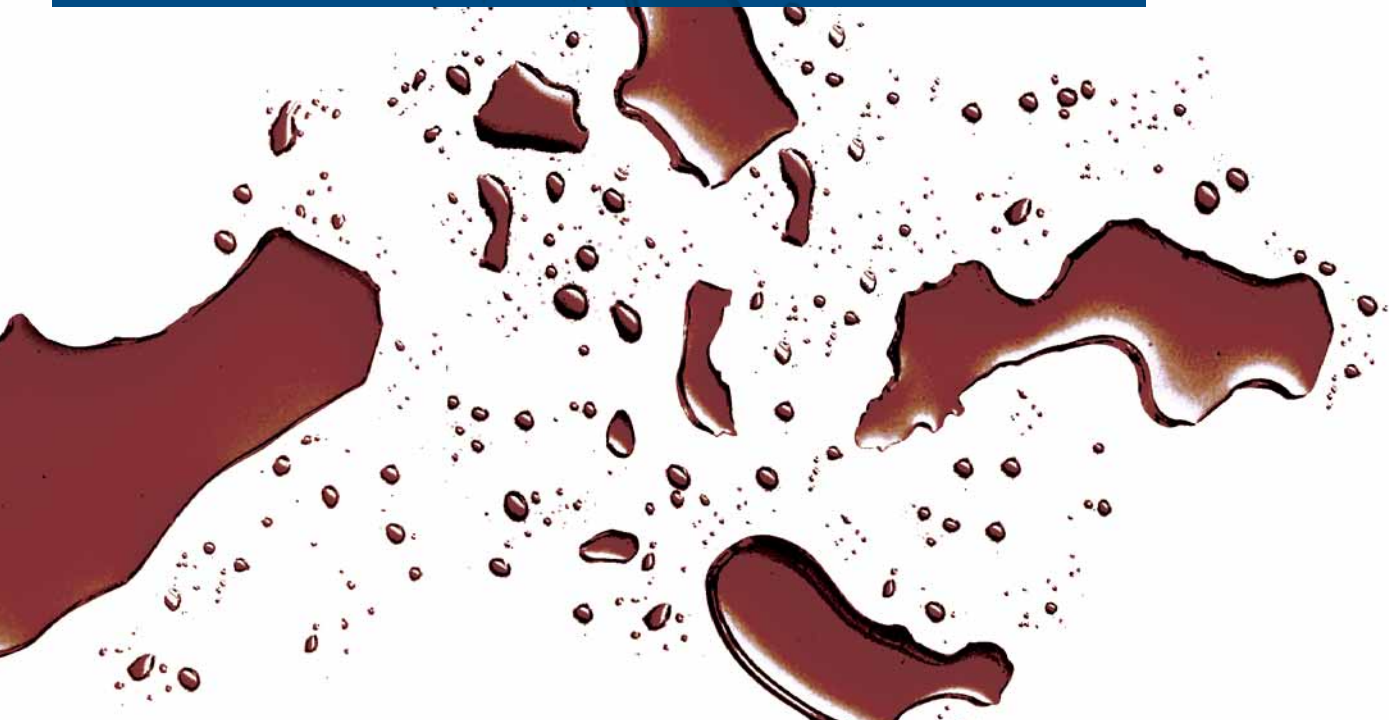

| Oil |  Operating -20°C to +20°C Ambient -40°C to -15°C |  Operating +10°C to +50°C Ambient -15°C to +15°C |  Operating +40°C to +70°C Ambient +15°C to +30°C |  Operating +50°C to +85°C Ambient +30°C to +50°C | Grease |
|---|--|--|--|--|----------------------|
| | ISO-VG/DIN 51519 mm ² /s | 10 | 22 | 46 | |
|          | SUMOROL | SUMOROL | SUMOROL CM 46 | DEGOL CL 100 T | ARALUB |
| | CM10 | CM22 | MOTANOL HE 46 | MOTANOL HE 100 | HL2 |
| | ENERGOL | ENERGOL | ENERGOL CS 46 | ENERGOL CS 100 | ENERGREASE |
| | CS10 | CS22 | ENERGOL RC-R 46 | ENERGOL RC 100 | LS2 |
| | — | — | AIRCOL | AIRCOL | SPHEEROL |
| | — | — | PD 46 | PD 100 | MP 2 |
| | SPINESSO | SPINESSO | TERESSTIC | NUTO | UNIREX |
| | 10 | 22 | T46 | 100 | N2 |
| | RENOLIN | RENOLIN | RENOLIN | RENOLIN | RENOLIT |
| | MR3 | DTA22 | DTA46 | MR30 | LZR2 |
| | ISOFLEX | ISOFLEX | LAMORA | LAMORA | POLYLUB WH2 |
| | PDP 38 | PDP 48 | HLP 46 | 100 | Klübersynth BM 44-42 |
| VELOCITE | VELOCITE | MOBIL | MOBIL DTE | POLYREX | |
| No 6 | No 10 | DTE 798 | OIL HEAVY | EM | |
| MORLINA | MORLINA | MORLINA | MORLINA | ALVANIA | |
| 10 | 22 | 46 | 100 | RL2 | |
| AZZOLA | AZZOLA | AZZOLA | AZZOLA | MULTIS 2 | |
| ZS10 | ZS22 | ZS46 | ZS100 | | |

OIL

DThe oil lubricated freewheels from this catalogue are delivered lubricated if they are sealed, self-contained units (except ALP..F7D7, GFRN..F5F6 and GFR..F3F4).

Other freewheels are delivered without lubricant, other than a protection against corrosion. Before putting a unit into operation, it is necessary to remove the anti corrosive fluid and to fill the unit with appropriate oil. Generally, for a horizontally mounted unit, the correct oil level is 1/3 of the internal clutch height unless specified. (For vertically mounted units please contact us). Correct lubricants to use are given in the lubrication chart.

Oils including graphite, molybdenum and EP additives should be avoided. This chart is for guidance only. In the case of low or high overrunning speeds, or limiting temperatures, please contact our technical department.

Note: Unlike all other designs, sprag types RSCI can work with all the current lubricants used in power transmissions.

Initially change the oil after 10 hours of operation. Afterwards every 2000 hours, every 1000 hours in a dirty environment.

Level and oil condition as well as rotating seals should be checked regularly. For working temperatures below -40°C and above $+100^{\circ}\text{C}$, please contact us.

If grease lubrication is the only option for one of these types, we recommend you contact our technical department for approval.

GREASE

A number of models have been designed specially for grease lubrication as standard (» see page 14–15).

In this case, the unit will always be delivered lubricated, ready for mounting either in horizontal or vertical position. The grease used is a long life type, with high thermal and chemical stability.

Unless specified, no maintenance is required. To increase the service life of units we recommend to remove, clean, inspect and re-grease them after two years of operation

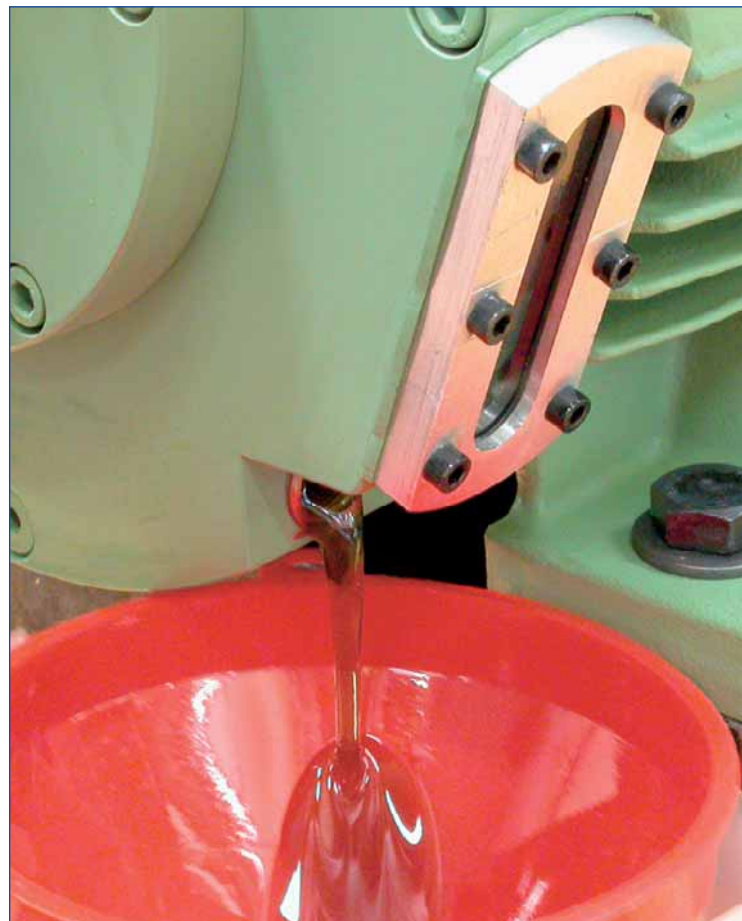

CSK CSK..2RS



TYPE

CSK..2RS



CSK

Type CSK is a sprag type freewheel integrated into a 62 series ball bearing (except sizes 8 and 40). It is bearing supported, delivered grease lubricated and protected against dust of more than 0,3 mm. The use of additional "nylos" type seals is recommended especially when the working temperature exceeds 50°C. Oil bath lubrication is also possible.

All the CSK versions are equipped with "formchromed" sprags. This process increases several times the

overrunning life time. Torque transmission is ensured by a press fit assembly into a rigid outer housing with N6 tolerance, and onto a shaft with n6 tolerance. The initial bearing radial clearance is set at C5, and is reduced if using the press fit as specified.

Please contact us when either the ambient or the operating temperature is not within the range +5°C to +60°C. CSK..2RS is 5 mm wider but is equipped with lip seals to be water splash resistant.

CSK

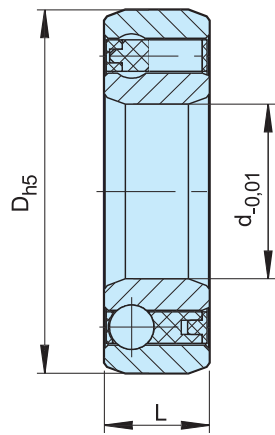

CSK..2RS

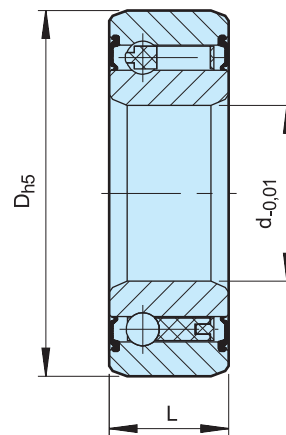

| Type | Size | Bearing series | | | | | Bearing loads | | Weight [kg] | Drag torque T_R [Ncm] |
|----------|--------------------|----------------|-----------------------|-----------------------------------|-----------|-----------|----------------------|----------------------------------|----------------|-------------------------------|
| | | | $T_{KN}^{1)}$ [Nm] | n_{max} [min ⁻¹] | D [mm] | L [mm] | dynamic C [kN] | static C ₀ [kN] | | |
| CSK (KK) | \varnothing^* | — | 2,5 | 15000 | 22 | 9 | 3,28 | 0,86 | 0,015 | 0,5 |
| | 12 | 6201 | 9,3 | 10000 | 32 | 10 | 6,1 | 2,77 | 0,04 | 0,7 |
| | 15 | 6202 | 17 | 8400 | 35 | 11 | 7,4 | 3,42 | 0,06 | 0,9 |
| | 17 | 6203 | 30 | 7350 | 40 | 12 | 7,9 | 3,8 | 0,070 | 1,1 |
| | 20 | 6204 | 50 | 6000 | 47 | 14 | 9,4 | 4,46 | 0,110 | 1,3 |
| | 25 | 6205 | 85 | 5200 | 52 | 15 | 10,7 | 5,46 | 0,140 | 2,0 |
| | 30 | 6206 | 138 | 4200 | 62 | 16 | 11,7 | 6,45 | 0,210 | 4,4 |
| | 35 | 6207 | 175 | 3600 | 72 | 17 | 12,6 | 7,28 | 0,300 | 5,8 |
| | 40 | — | 325 | 3000 | 80 | 22 | 15,54 | 12,25 | 0,5 | 7,0 |
| CSK..2RS | \varnothing^{**} | — | 2,5 | 15000 | 22 | 9 | 3,28 | 0,86 | 0,015 | 0,8 |
| | 12 | — | 9,3 | 10000 | 32 | 14 | 6,1 | 2,77 | 0,05 | 3,0 |
| | 15 | — | 17 | 8400 | 35 | 16 | 7,4 | 3,42 | 0,070 | 4,0 |
| | 17 | — | 30 | 7350 | 40 | 17 | 7,9 | 3,8 | 0,09 | 5,6 |
| | 20 | — | 50 | 6000 | 47 | 19 | 9,4 | 4,46 | 0,145 | 6,0 |
| | 25 | — | 85 | 5200 | 52 | 20 | 10,7 | 5,46 | 0,175 | 6,0 |
| | 30 | — | 138 | 4200 | 62 | 21 | 11,7 | 6,45 | 0,270 | 7,5 |
| | 35 | — | 175 | 3600 | 72 | 22 | 12,6 | 7,28 | 0,400 | 8,2 |
| | 40 | — | 325 | 3000 | 80 | 27 | 15,54 | 12,25 | 0,6 | 10 |

NOTES

1) $T_{max} = 2 \times T_{KN}$

» Refer to Selection page 10 to 13

*) One Z seal on the bearing side only. Looking from this side, the outer race runs free in the counterclockwise direction

**) Only one RS seal on the ball bearing side looking from this side, the outer race runs free in the counterclockwise direction

» Refer to mounting and maintenance instructions page 16 to 19

MOUNTING EXAMPLES

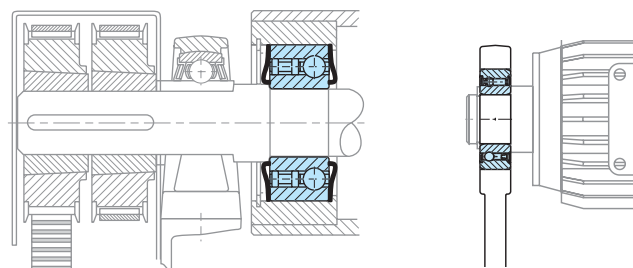

CSK..P CSK..PP CSK..P-2RS



TYPE

CSK..PP



CSK..P



Types CSK..P and CSK..PP are sprag type freewheels integrated into 62.. series ball bearings (except size 40). They are bearing supported, delivered grease lubricated and protected against dust of more than 0.3 mm.

The use of additional “nylos” type seals is recommended especially when the working temperature exceeds 50°C. Oil bath lubrication is also possible.

In addition to the basic CSK model, type CSK..P features a keyway on the inner race. For this reason it can

be keyed to a shaft to k6 tolerance. The outer race must still be pressed into a rigid housing to N6 tolerance.

CSK..PP features a keyway on both the inner and outer race. The recommended mounting tolerances are h6 on the shaft and H6 in a rigid housing. Please contact us when either the ambient or the operating temperature is not within the range +5°C to +60°C.

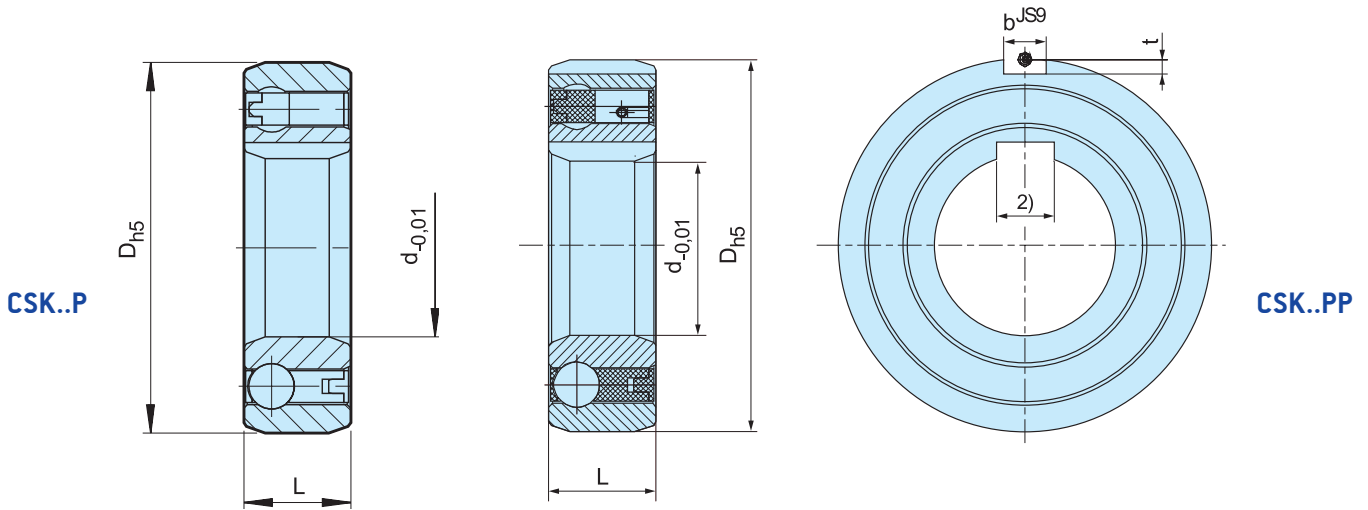

| Type | Size | Bearing series | | | | | | | Bearing loads | | Weight (kg) | Drag torque T_R (Ncm) |
|--------------------------|------|----------------|-----------------------|-----------------------------------|-----------|-----------|-----------|-----------|----------------------|----------------------------------|----------------|-------------------------------|
| | | | $T_{KN}^{1)}$ (Nm) | n_{max} (min ⁻¹) | D (mm) | L (mm) | b (mm) | t (mm) | dynamic C (kN) | static C ₀ (kN) | | |
| CSK..P ²⁾ | 12 | 6201 | 9,3 | 10000 | 32 | 10 | | | 6,1 | 2,77 | 0,04 | 0,7 |
| | 15 | 6202 | 17 | 8400 | 35 | 11 | | | 7,4 | 3,42 | 0,06 | 0,9 |
| | 17 | 6203 | 30 | 7350 | 40 | 12 | | | 7,9 | 3,8 | 0,070 | 1,1 |
| | 20 | 6204 | 50 | 6000 | 47 | 14 | | | 9,4 | 4,46 | 0,110 | 1,3 |
| | 25 | 6205 | 85 | 5200 | 52 | 15 | | | 10,7 | 5,46 | 0,140 | 2,0 |
| | 30 | 6206 | 138 | 4200 | 62 | 16 | | | 11,7 | 6,45 | 0,210 | 4,4 |
| | 35 | 6207 | 175 | 3600 | 72 | 17 | | | 12,6 | 7,28 | 0,300 | 5,8 |
| | 40 | — | 325 | 3000 | 80 | 22 | | | 15,54 | 12,25 | 0,5 | 7,0 |
| CSK..PP ²⁾ | 15 | 6202 | 17 | 8400 | 35 | 11 | 2 | 0,6 | 7,4 | 3,42 | 0,06 | 0,9 |
| | 17 | 6203 | 30 | 7350 | 40 | 12 | 2 | 1,0 | 7,9 | 3,8 | 0,070 | 1,1 |
| | 20 | 6204 | 50 | 6000 | 47 | 14 | 3 | 1,5 | 9,4 | 4,46 | 0,110 | 1,3 |
| | 25 | 6205 | 85 | 5200 | 52 | 15 | 6 | 2,0 | 10,7 | 5,46 | 0,140 | 2,0 |
| | 30 | 6206 | 138 | 4200 | 62 | 16 | 6 | 2,0 | 11,7 | 6,45 | 0,210 | 4,4 |
| | 35 | 6207 | 175 | 3600 | 72 | 17 | 8 | 2,5 | 12,6 | 7,28 | 0,300 | 5,8 |
| | 40 | — | 325 | 3000 | 80 | 22 | 10 | 3,0 | 15,54 | 12,25 | 0,5 | 7,0 |
| CSK..P-2RS ²⁾ | 12 | — | 9,3 | 10000 | 32 | 14 | | | 6,1 | 2,77 | 0,05 | 3 |
| | 15 | — | 17 | 8400 | 35 | 16 | | | 7,4 | 3,42 | 0,07 | 4 |
| | 17 | — | 30 | 7350 | 40 | 17 | | | 7,9 | 3,8 | 0,09 | 5,6 |
| | 20 | — | 50 | 6000 | 47 | 19 | | | 9,4 | 4,46 | 0,145 | 6,0 |
| | 25 | — | 85 | 5200 | 52 | 20 | | | 10,7 | 5,46 | 0,175 | 6,0 |
| | 30 | — | 138 | 4200 | 62 | 21 | | | 11,7 | 6,45 | 0,270 | 7,5 |
| | 35 | — | 175 | 3600 | 72 | 22 | | | 12,6 | 7,28 | 0,4 | 8,2 |
| | 40 | — | 325 | 3000 | 80 | 27 | | | 15,54 | 12,25 | 0,6 | 10 |

NOTES

1) $T_{max} = 2 \times T_{KN}$

» Refer to Selection page 10 to 13

2) Keyway to DIN 6885.3

Size 40 keyway to DIN 6885.1

» Refer to mounting and maintenance instructions page 16 to 19

MOUNTING EXAMPLE

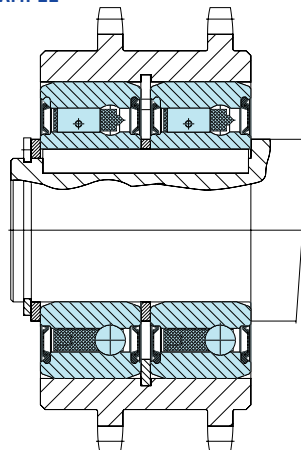

ASK

TYPE



Type ASK is a roller type freewheel bearing supported by two rows of roller bearings. It is a self-contained dust protected unit, delivered grease lubricated.

Nominal outside dimensions are the same as a 60.. series bearing. Torque transmission must be ensured by a press fit on both the inner and outer race. Because of this press fit, the standard radial clearance is C4. The interference tolerances are on the freewheel dimensions,

allowing a direct mounting in a standard series 60.. bearing location: Shaft tolerance should be h6 or j6 The outer race should be pressed into a rigid housing to K6 tolerance.

Radial bearing load capacities are given in the table. Type ASK freewheels can not accept axial loading. In cases of such loads, thrust bearings must be provided.

ASK

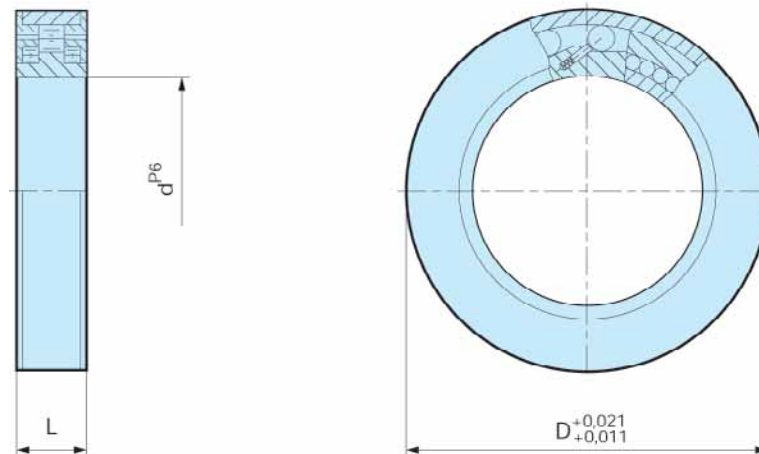

| Type | Size | Bearing series | | | | | Bearing loads | | Weight (kg) | Drag torque TR (Ncm) |
|------|-------------------------|----------------|-----------------------|-----------------------------------|-----------|-----------|----------------------|----------------------------------|----------------|----------------------------|
| | | | $T_{KN}^{1)}$ (Nm) | n_{max} (min ⁻¹) | D (mm) | L (mm) | dynamic C (kN) | static C ₀ (kN) | | |
| ASK | d ^{P6} (mm) | | | | | | | | | |
| | 40 | 6008 | 72 | 3500 | 68 | 15 | 16 | 20,6 | 0,25 | 15 |
| | 50 | 6010 | 125 | 2200 | 80 | 16 | 19,6 | 23,5 | 0,34 | 20 |
| | 60 | 6012 | 250 | 1800 | 95 | 18 | 25,3 | 35,1 | 0,5 | 25 |

NOTES

1) $T_{max} = 2 \times T_{KN}$

» Refer to Selection page 10 to 13

» Refer to mounting and maintenance instructions
page 16 to 19

MOUNTING EXAMPLE

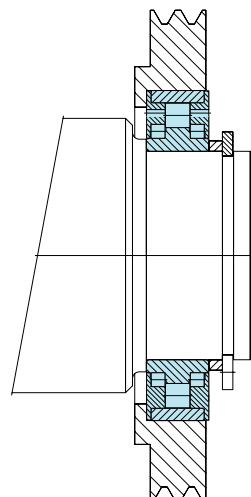

GFK



TYPE



Type GFK is a sprag type freewheel integrated into a 59.. series ball bearing. This design provides high torque capacity for minimal outside diameter. It is a bearing supported type, delivered grease lubricated.

Oil bath lubrication is also possible. Whatever the lubrication type, seals should be provided, as illustrated on the next page.

Torque transmission must be ensured by a press fit assembly into a rigid outer housing with R6 tolerance, and onto a shaft with p5 tolerance.

Initial radial clearance has been provided to take into account this heavy press fit. Operating temperature range: -20°C to $+100^{\circ}\text{C}$. Peaks up to $+120^{\circ}\text{C}$ are acceptable for short periods. Please contact us for higher temperatures.

GFK

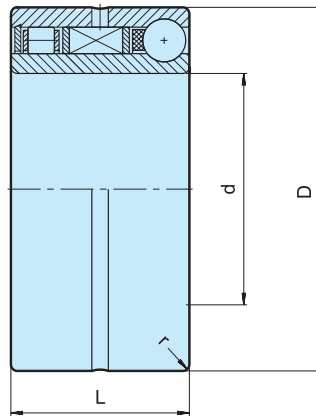

| Type | Size | Overrunning speeds | | | Bearing series | Loads | | | | | | | Weight (kg) |
|------|------|-----------------------|---|---|----------------|-----------------------------|---------------------------|---|---|-----------|-----------|-----------|----------------|
| | | $T_{KN}^{1)}$ (Nm) | $n_{imax}^{2)}$ (min ⁻¹) | $n_{amax}^{3)}$ (min ⁻¹) | | Rollers dyn. C (N) | Balls dyn. C (N) | Rollers stat. C ₀ (N) | Balls stat. C ₀ (N) | D (mm) | L (mm) | r (mm) | |
| GFK | 20 | 51 | 5500 | 4000 | 5904 | 5600 | 4400 | 2900 | 2750 | 37 | 23 | 0,5 | 0,09 |
| | 25 | 65 | 5300 | 3800 | 5905 | 6300 | 5300 | 3450 | 3350 | 42 | 23 | 0,5 | 0,11 |
| | 30 | 95 | 5000 | 3500 | 5906 | 7700 | 5500 | 4600 | 3650 | 47 | 23 | 0,5 | 0,13 |
| | 35 | 204 | 4600 | 3200 | 5907 | 8200 | 8500 | 5200 | 5700 | 55 | 27 | 1 | 0,20 |
| | 40 | 315 | 4200 | 3000 | 5908 | 8650 | 9300 | 5750 | 6700 | 62 | 30 | 1 | 0,30 |
| | 45 | 370 | 3800 | 2500 | 5909 | 9200 | 9700 | 6350 | 7300 | 68 | 30 | 1 | 0,34 |
| | 50 | 460 | 3400 | 2200 | 5910 | 9650 | 10000 | 6950 | 7800 | 72 | 30 | 1 | 0,36 |

NOTES

- 1) $T_{max} = 2 \times T_{KN}$
» Refer to Selection page 10 to 13
 - 2) Inner race overruns
 - 3) Outer race overruns
- » Refer to mounting and maintenance instructions page 16 to 19

MOUNTING EXAMPLE

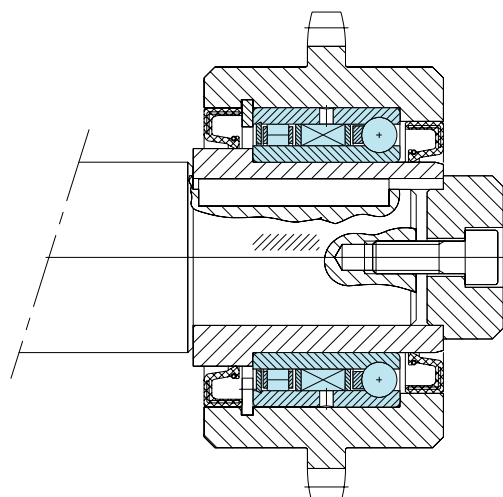

KI

TYPE



Type KI is a roller type freewheel. It is an assembly comprising of an inner race and rollers fitted into a polyamide cage. This type of unit can not be dismantled. It is designed for small mechanisms in office equipment, or packaging machines, to be mounted inside gears or feed rollers.

The gear or feed roller inner diameter is used as the outer race. Additional bearing support is required, and the freewheel must not be subjected to axial loading; mounting

examples are shown on the following page. The outer race does not need to be hardened; min. strength: 700 N/mm^2

The surface roughness will not exceed 22 CLA.

Mounting onto the shaft can be a press fit to r6 tolerance or a glue fit with a clearance of 0,02 to 0,05mm.

Sizes 8 mm and above can be supplied with a keyway. Temperature range: -40°C to $+100^\circ\text{C}$ (continuous operation). Peak temperatures of $+120^\circ\text{C}$ are acceptable for short periods of time.

KI

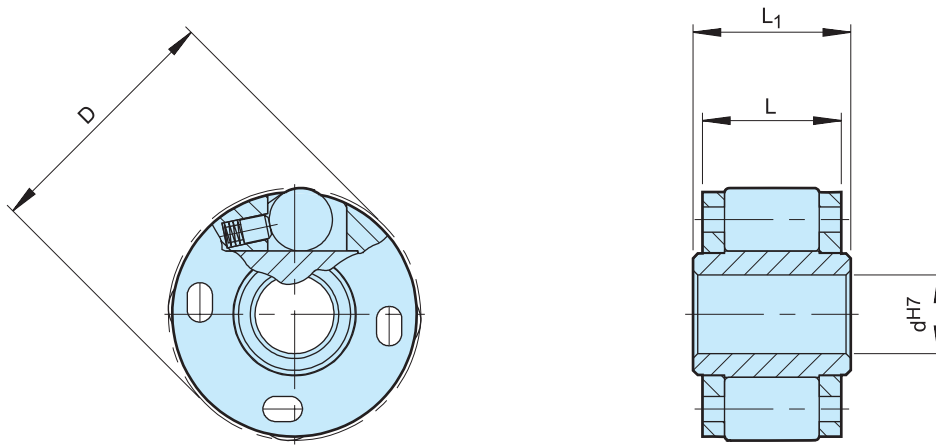

| Type | Size | Overrunning speeds | | | D ^{H7} [mm] | d ^{H7} [mm] | L ₁ [mm] | L [mm] | Weight [kg] |
|------|-------|---------------------------------------|---|---|-------------------------|-------------------------|------------------------|-----------|----------------|
| | | T _{KN} ¹⁾ [Nm] | n _{imax} ²⁾ [min ⁻¹] | n _{amax} ³⁾ [min ⁻¹] | | | | | |
| Ki | 164 | 0,8 | 8000 | 10000 | 16 | 4 | 10 | 9 | 0,008 |
| | 165 | 0,8 | 8000 | 10000 | 16 | 5 | 10 | 9 | 0,007 |
| | 194 | 0,9 | 7000 | 9000 | 19 | 4 | 10 | 9 | 0,012 |
| | 195 | 0,9 | 7000 | 9000 | 19 | 5 | 10 | 9 | 0,011 |
| | 196 | 0,9 | 7000 | 9000 | 19 | 6 | 10 | 9 | 0,010 |
| | 268* | 2,9 | 5000 | 6000 | 26 | 8 | 14 | 13 | 0,023 |
| | 269* | 2,9 | 5000 | 6000 | 26 | 9 | 14 | 13 | 0,021 |
| | 2610* | 2,9 | 5000 | 6000 | 26 | 10 | 14 | 13 | 0,019 |

NOTES

1) $T_{\max} = 2 \times T_{KN}$

» Refer to Selection page 10 to 13

*) Can be also supplied with a keyway to DIN 6885.1

2) Inner race overruns

3) Outer race overruns

» Refer to mounting and maintenance instructions page 16 to 19

MOUNTING EXAMPLES

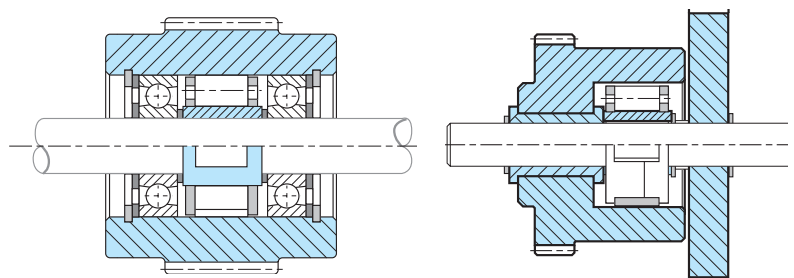

AS

TYPE



Type AS is a roller type freewheel non-bearing supported. Bearings are required to support axial and radial loads. Lubrication and sealing must also be provided by the installation. Nominal outside dimensions are the same as series 62.. ball bearings.

A typical arrangement is to install this type alongside a series 62 bearing within the same location tolerances, as shown on the following page.

The inner race is keyed to the shaft (except 6 mm bore). The outer race has a positive r6 tolerance to give a press fit in a H7 housing. The outer housing must be strong enough to not expand after assembly. This design can accept an axial misalignment of inner and outer race of $\pm S/2$.

AS

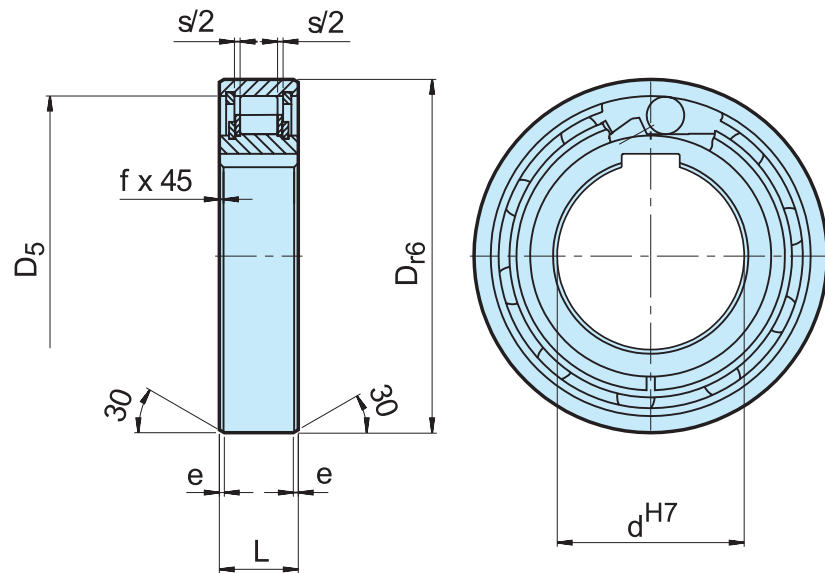

| Type | Size | Overrunning speeds | | | | | | | | | Weight | Drag torque |
|----------|------|-----------------------|---|---|------------------|---------------|-----------|-----------|-----------|-----------|--------|-------------|
| | | $T_{KN}^{1)}$ [Nm] | $n_{imax}^{2)}$ [min ⁻¹] | $n_{amax}^{3)}$ [min ⁻¹] | D_{r6} [mm] | D_5 [mm] | L [mm] | s [mm] | e [mm] | f [mm] | | |
| AS (NSS) | 6 | 2,10 | 5000 | 7500 | 19 | 15,8 | 6 | 0,3 | 0,6 | 0,3 | 0,01 | 0,18 |
| | 8 | 3,8 | 4300 | 6500 | 24 | 20 | 8 | 1,3 | 0,6 | 0,6 | 0,02 | 0,24 |
| | 10 | 6,8 | 3500 | 5200 | 30 | 25,9 | 9 | 1,3 | 0,6 | 0,6 | 0,03 | 0,36 |
| | 12 | 13 | 3200 | 4800 | 32 | 28 | 10 | 1,3 | 0,6 | 0,6 | 0,04 | 0,48 |
| | 15 | 14 | 2800 | 4300 | 35 | 31 | 11 | 1,4 | 0,6 | 0,6 | 0,05 | 0,70 |
| | 20 | 40 | 2200 | 3300 | 47 | 40 | 14 | 2,4 | 0,8 | 0,8 | 0,12 | 1,4 |
| | 25 | 56 | 1900 | 2900 | 52 | 45,9 | 15 | 2,4 | 0,8 | 0,8 | 0,14 | 2,4 |
| | 30 | 90 | 1600 | 2400 | 62 | 55 | 16 | 2,4 | 0,8 | 1 | 0,22 | 7,8 |
| | 35 | 143 | 1300 | 2000 | 72 | 64 | 17 | 2,5 | 0,8 | 1 | 0,31 | 9,0 |
| | 40 | 185 | 1200 | 1800 | 80 | 72 | 18 | 2,5 | 0,8 | 1 | 0,39 | 10 |
| | 45 | 218 | 1000 | 1600 | 85 | 77 | 19 | 2,5 | 1,2 | 1 | 0,44 | 11 |
| | 50 | 230 | 950 | 1500 | 90 | 82 | 20 | 2,5 | 1,2 | 1 | 0,49 | 13 |
| | 55 | 308 | 800 | 1300 | 100 | 90 | 21 | 2,5 | 1,2 | 1 | 0,66 | 14 |
| | 60 | 508 | 700 | 1100 | 110 | 100 | 22 | 2,5 | 1,2 | 1,5 | 0,81 | 26 |
| | 80 | 1063 | 600 | 900 | 140 | 128 | 26 | 2,5 | 1,2 | 1,5 | 1,41 | 58 |

NOTES

AS6 without keyway. $\varnothing D = \begin{smallmatrix} -0 \\ -0,009 \end{smallmatrix}$
 AS8-12 keyway to DIN 6885.1.
 Other sizes to DIN 6885.3

1) $T_{max} = 2 \times T_{KN}$
 » Refer to Selection page 10 to 13

2) Inner race overruns

3) Outer race overruns

Mounting dimensions are identical to ball bearings series 62.
 » Refer to mounting and maintenance instructions
 page 16 to 19

MOUNTING EXAMPLE

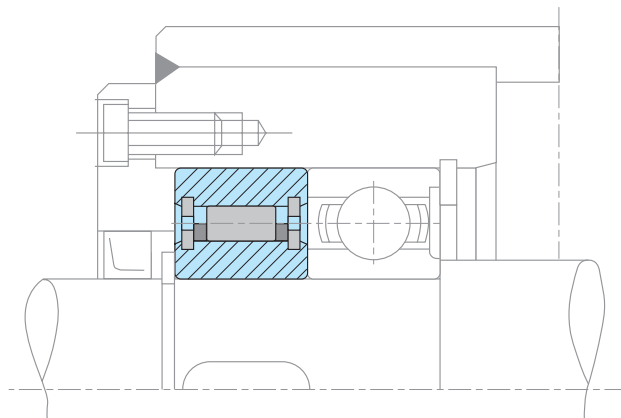

ASNU

TYPE



Type ASNU is a roller type freewheel non-bearing supported. Bearings are required to support axial and radial loads. Lubrication and sealing must also be provided by the installation. Nominal outer diameter is the same as a series 63.. ball bearing.

A typical arrangement is to install this type alongside a bearing within the same location tolerances, as shown on the following page. The inner race is keyed to the shaft.

The outer race has positive $n6$ tolerance, to give a press fit in a H7 housing. Additional side notches in the outer race provide for positive torque transmission.

If the housing is to K6 tolerance, use of the notches is not necessary, but the housing must be strong enough to not expand after assembly. This design can accept an axial misalignment of inner and outer race of $\pm S/2$.

ASNU

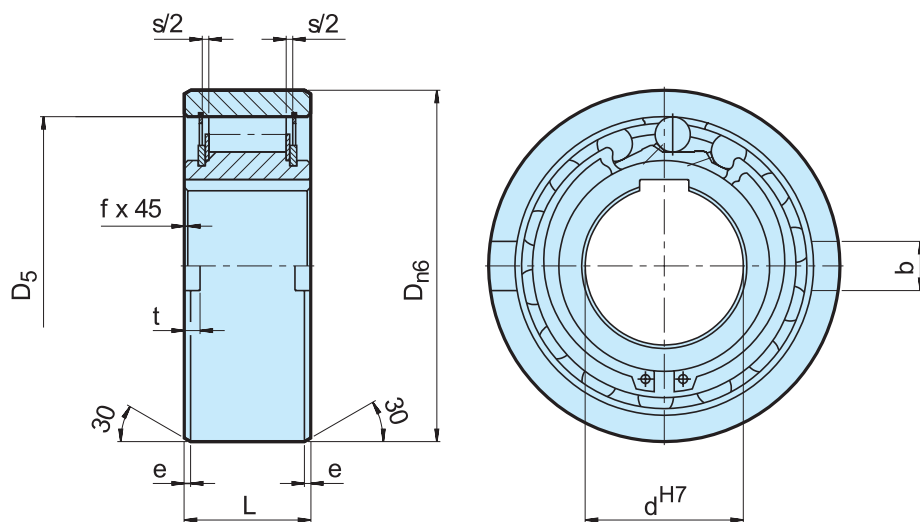

| Type | Size | Overrunning Speeds | | | | | | | | | | | Weight (kg) | Drag torque T_R (Ncm) |
|------|-------|--------------------|-----------------------|---|---|------------------|-----------|---------------|-----------|-----------|-----------|-----------|----------------|-------------------------------|
| | | d^{H7} (mm) | $T_{KN}^{1)}$ (Nm) | $n_{imax}^{2)}$ (min ⁻¹) | $n_{amax}^{3)}$ (min ⁻¹) | D_{n6} (mm) | L (mm) | D_5 (mm) | b (mm) | t (mm) | s (mm) | e (mm) | | |
| ASNU | 8 | 12 | 3300 | 5000 | 35 | 13 | 28 | 4 | 1.4 | 2.4 | 0.6 | 0.3 | 0.07 | 1.6 |
| | 12 | 12 | 3300 | 5000 | 35 | 13 | 28 | 4 | 1.4 | 2.4 | 0.6 | 0.3 | 0.06 | 1.6 |
| | 15 | 30 | 2400 | 3600 | 42 | 18 | 37 | 5 | 1.8 | 2.4 | 0.8 | 0.3 | 0.11 | 1.9 |
| | 17 | 49 | 2300 | 3400 | 47 | 19 | 40 | 5 | 2.3 | 2.4 | 1.2 | 0.8 | 0.15 | 1.9 |
| | 20 | 78 | 2100 | 3100 | 52 | 21 | 42 | 6 | 2.3 | 2.4 | 1.2 | 0.8 | 0.19 | 1.9 |
| | 25 | 125 | 1700 | 2600 | 62 | 24 | 51 | 8 | 2.8 | 2.4 | 1.2 | 0.8 | 0.38 | 5.6 |
| | 30 | 255 | 1400 | 2200 | 72 | 27 | 60 | 10 | 2.5 | 2.4 | 1.8 | 1 | 0.54 | 14 |
| | 35 | 383 | 1200 | 1900 | 80 | 31 | 70 | 12 | 3.5 | 2.4 | 1.8 | 1 | 0.74 | 16 |
| | 40 | 538 | 1100 | 1700 | 90 | 33 | 78 | 12 | 4.1 | 2.5 | 1.8 | 1 | 0.92 | 38 |
| | 45 | 780 | 1000 | 1600 | 100 | 36 | 85 | 14 | 4.6 | 2.5 | 1.8 | 1 | 1.31 | 43 |
| | 50 | 1013 | 850 | 1350 | 110 | 40 | 92 | 14 | 5.6 | 2.5 | 1.8 | 1 | 1.74 | 55 |
| | 60 | 1825 | 750 | 1050 | 130 | 46 | 110 | 18 | 5.5 | 3.6 | 2.6 | 1.5 | 2.77 | 110 |
| | 70 | 2300 | 600 | 950 | 150 | 51 | 125 | 20 | 6.9 | 3.6 | 2.6 | 1.5 | 4.16 | 140 |
| | 80 | 3275 | 550 | 850 | 170 | 58 | 140 | 20 | 7.5 | 3.6 | 2.6 | 1.5 | 6.09 | 180 |
| | 90 | 5325 | 500 | 750 | 190 | 64 | 160 | 20 | 8.0 | 3.6 | 2.6 | 2 | 8.2 | 230 |
| | 100 | 7250 | 450 | 680 | 215 | 73 | 175 | 24 | 8.5 | 3.6 | 2.6 | 2 | 12.6 | 380 |
| | 120 | 13500 | 370 | 550 | 260 | 86 | 215 | 28 | 10 | 3.6 | 2.6 | 2.5 | 22 | 650 |
| | 150 | 26625 | 300 | 460 | 320 | 108 | 260 | 32 | 12 | 3.6 | 3.6 | 2.5 | 42 | 1000 |
| 200 | 44500 | 230 | 350 | 420 | 138 | 350 | 45 | 16 | 7.6 | 3.6 | 3 | 93 | 2000 | |

NOTES

ASNU8-12, ASNU200 keyway to DIN 6885. 1.
other sizes to DIN 6885.3

1) $T_{max} = 2 \times T_{KN}$

» Refer to Selection page 10 to 13

2) Inner race overruns

3) Outer race overruns

» Refer to mounting and maintenance instructions
page 16 to 19

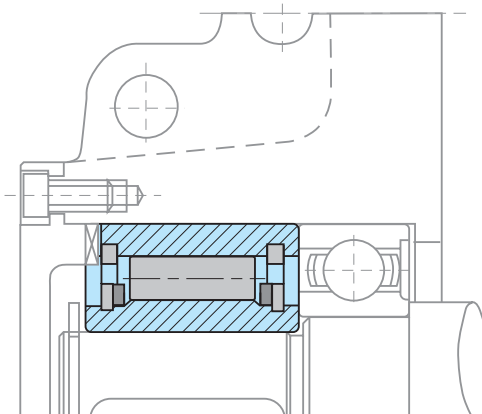
MOUNTING EXAMPLE

AE

TYPE



Type AE is a roller type freewheel non-bearing supported. Bearings are required to support axial and radial loads. Lubrication and sealing must also be provided by the installation. Nominal outside diameter is a standard ball bearing dimension.

A typical arrangement is to install this type beside a bearing with the same housing diameter tolerance as shown on the following page.

The inner race is keyed to the shaft. The outer race has a h6 tolerance and should be fitted in a housing with a K7 tolerance. Additional side notches provide for positive torque transmission.

If the housing tolerance is to R6, use of the notches is not necessary, but the housing must be strong enough to not expand after assembly. This design can accept an axial misalignment of inner and outer race of $\pm S/2$.

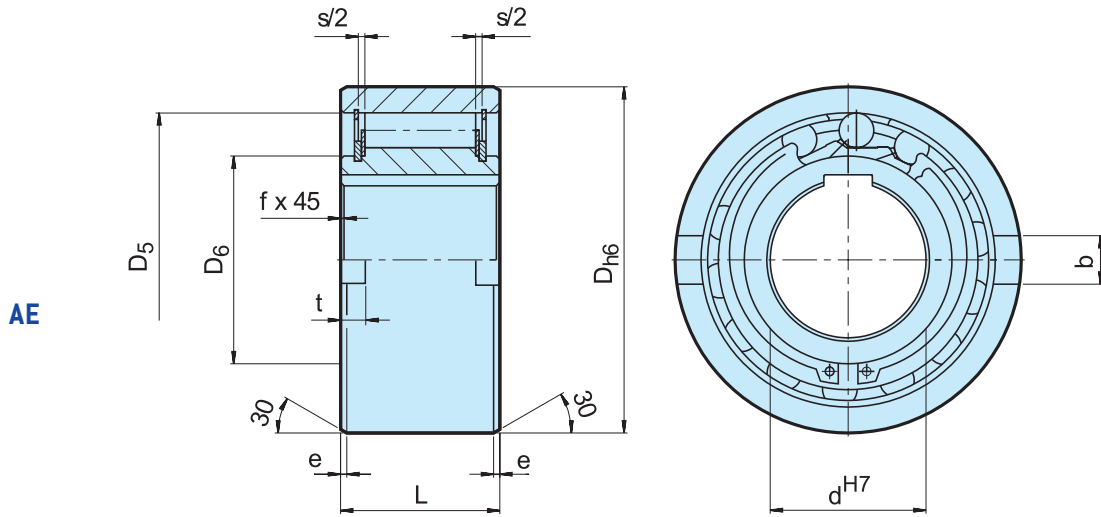

| Type | Size | Overrunning speeds | | | | | | | | | | | Weight (kg) | Drag torque T_R (Ncm) | |
|------|------|-----------------------|---|---|------------------|---------------|---------------|-----------|-----------|-----------|-----------|-----------|----------------|-------------------------------|-----------|
| | | $T_{KN}^{1)}$ (Nm) | $n_{imax}^{2)}$ (min ⁻¹) | $n_{smax}^{3)}$ (min ⁻¹) | D_{H6} (mm) | D_5 (mm) | D_6 (mm) | L (mm) | s (mm) | f (mm) | e (mm) | b (mm) | | | t (mm) |
| AE | 12 | 17 | 3100 | 6000 | 37 | 28 | 20 | 20 | 4,5 | 0,5 | 0,8 | 6 | 3 | 0,11 | 0,7 |
| | 15 | 55 | 2300 | 5400 | 47 | 37 | 26 | 30 | 4,5 | 0,8 | 1,2 | 7 | 3,5 | 0,30 | 3,5 |
| | 20 | 146 | 2000 | 3600 | 62 | 50 | 35 | 34 | 5,5 | 0,8 | 1,2 | 8 | 3,5 | 0,55 | 8,4 |
| | 25 | 285 | 1700 | 2600 | 80 | 68 | 45 | 37 | 6,5 | 1 | 1,8 | 9 | 4 | 0,98 | 14 |
| | 30 | 500 | 1500 | 2100 | 90 | 75 | 50 | 44 | 6,2 | 1 | 1,8 | 12 | 5 | 1,50 | 23 |
| | 35 | 720 | 1300 | 1950 | 100 | 80 | 55 | 48 | 3,8 | 1 | 1,8 | 13 | 6 | 2,00 | 60 |
| | 40 | 1030 | 1200 | 1700 | 110 | 90 | 60 | 56 | 3,8 | 1,5 | 1,8 | 15 | 7 | 2,80 | 72 |
| | 45 | 1125 | 1050 | 1600 | 120 | 95 | 65 | 56 | 3,8 | 1,5 | 2,6 | 16 | 7 | 3,30 | 140 |
| | 50 | 2150 | 950 | 1300 | 130 | 110 | 75 | 63 | 5,8 | 1,5 | 2,6 | 17 | 8 | 4,20 | 180 |
| | 55 | 2675 | 850 | 1200 | 140 | 115 | 82 | 67 | 3,8 | 2 | 2,6 | 18 | 9 | 5,20 | 190 |
| | 60 | 3500 | 800 | 1100 | 150 | 125 | 90 | 78 | 7,6 | 2 | 2,6 | 18 | 9 | 6,80 | 240 |
| | 70 | 5813 | 650 | 900 | 170 | 140 | 100 | 95 | 7,6 | 2,5 | 2,6 | 20 | 9 | 10,5 | 320 |

NOTES

1) $T_{max} = 2 \times T_{KN}$
 » Refer to Selection page 10 to 13

2) Inner race overruns

3) Outer race overruns

Keyway to DIN 6885.1
 » Refer to mounting and maintenance instructions page 16 to 19

MOUNTING EXAMPLE

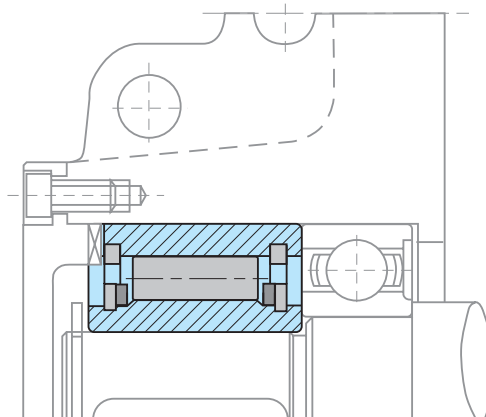

AA



TYPE



Type AA is a roller type freewheel non-bearing supported. Bearings are required to support axial and radial loads. Lubrication and sealing must also be provided by the installation.

Standard lubrication is oil. A typical installation is shown on the following page.

The inner race is keyed to the shaft. The fit for centering of the outer race must be to H7 tolerance. Connection of the outer race is via through bolts to grade 10.9 or better.

This design can accept an axial misalignment of inner and outer race of $\pm S/2$.

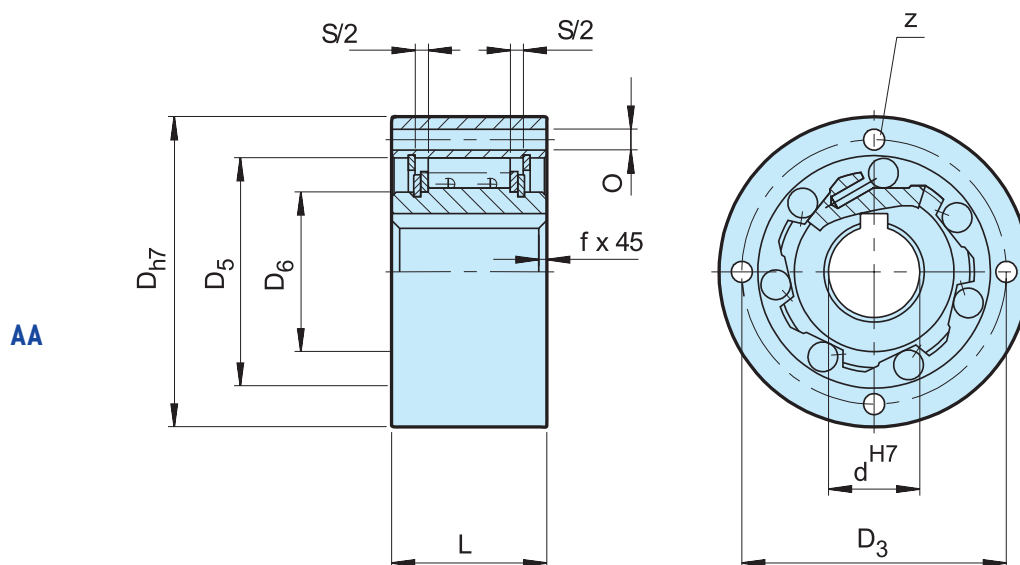

| Type | Size | Overrunning speeds | | | | | | | | | | | Weight | Drag torque | | |
|------|------|-----------------------|-----------------------|---|---|------------------|-----------|---------------|---------------|---------------|----|-----------|--------|-------------|-----------|-----------|
| | | $d_{H7}^{1)}$ [mm] | $T_{KN}^{1)}$ [Nm] | $n_{imax}^{2)}$ [min ⁻¹] | $n_{amax}^{3)}$ [min ⁻¹] | D_{h7} [mm] | L [mm] | D_5 [mm] | D_6 [mm] | D_3 [mm] | Z | o [mm] | | | f [mm] | s [mm] |
| AA | 12 | 17 | | 3100 | 6000 | 47 | 20 | 28 | 20 | 38 | 3 | 5,5 | 0,5 | 4,5 | 0,21 | 0,7 |
| | 15 | 55 | | 2300 | 5400 | 55 | 30 | 37 | 26 | 45 | 3 | 5,5 | 0,8 | 4,5 | 0,44 | 3,5 |
| | 20 | 146 | | 2000 | 3600 | 68 | 34 | 50 | 35 | 58 | 4 | 5,5 | 0,8 | 5,5 | 0,70 | 8,4 |
| | 25 | 285 | | 1700 | 2600 | 90 | 37 | 68 | 45 | 78 | 6 | 5,5 | 1 | 6,5 | 1,30 | 14 |
| | 30 | 500 | | 1500 | 2100 | 100 | 44 | 75 | 50 | 87 | 6 | 6,6 | 1 | 6,5 | 2,00 | 23 |
| | 35 | 720 | | 1300 | 1950 | 110 | 48 | 80 | 55 | 96 | 6 | 6,6 | 1 | 6,5 | 2,60 | 60 |
| | 40 | 1030 | | 1200 | 1700 | 125 | 56 | 90 | 60 | 108 | 6 | 9 | 1,5 | 7,6 | 3,90 | 72 |
| | 45 | 1125 | | 1050 | 1500 | 130 | 56 | 95 | 65 | 112 | 8 | 9 | 1,5 | 7,6 | 4,00 | 140 |
| | 50 | 2150 | | 950 | 1300 | 150 | 63 | 110 | 75 | 132 | 8 | 9 | 1,5 | 7,6 | 6,00 | 180 |
| | 55 | 2675 | | 850 | 1200 | 160 | 67 | 115 | 82 | 138 | 8 | 11 | 2 | 7,6 | 7,20 | 190 |
| | 60 | 3500 | | 800 | 1100 | 170 | 78 | 125 | 90 | 150 | 10 | 11 | 2 | 7,6 | 9,20 | 240 |
| | 70 | 5813 | | 650 | 900 | 190 | 95 | 140 | 100 | 165 | 10 | 11 | 2,5 | 7,6 | 11,8 | 320 |

NOTES

1) $T_{max} = 2 \times T_{KN}$
 » Refer to Selection page 10 to 13

2) Inner race overruns

3) Outer race overruns

Keyway to DIN 6885.1

» Refer to mounting and maintenance instructions
 page 16 to 19

MOUNTING EXAMPLE

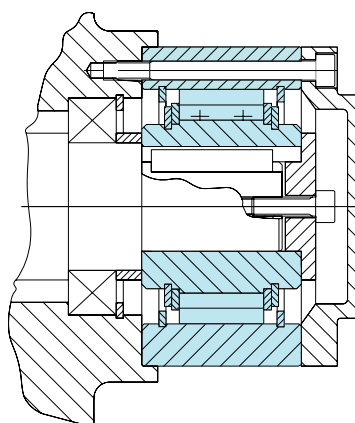

NF

TYPE



Type NF is a roller type freewheel non-bearing supported. Bearings are required to support axial and radial loads. Lubrication and sealing must also be provided by the installation.

Standard lubrication is oil. Nominal outside diameter is a standard ball bearing dimension. A typical arrangement is to install this type alongside a bearing with the same housing tolerances, as shown on the following page. The

inner race is keyed to the shaft. The outer race has a positive $n6$ tolerance to give a press fit in a H7 housing. Additional side notches provide for positive torque transmission.

If the housing tolerance is to K6, use of the notches is not necessary, but the housing must be strong enough to not expand after assembly.

NF

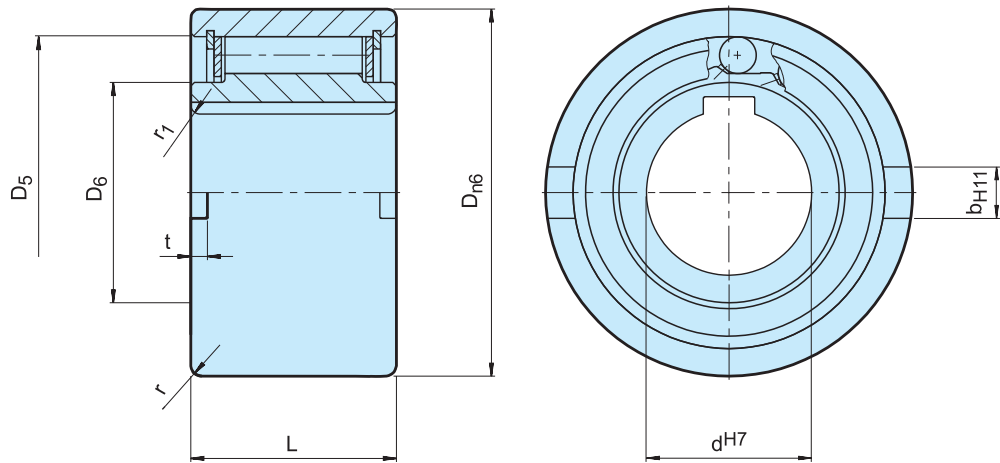

| Type | Size | Overrunning speeds | | | | | | | | | | | Weight [kg] |
|------|-------|-----------------------|---|---|------------------|---------------|---------------|-----------|-----------|-------------------|-----------|---------------|----------------|
| | | $T_{KN}^{1)}$ [Nm] | $n_{imax}^{2)}$ [min ⁻¹] | $n_{amax}^{3)}$ [min ⁻¹] | D_{n6} [mm] | D_5 [mm] | D_6 [mm] | L [mm] | t [mm] | b^{H11} [mm] | r [mm] | r_1 [mm] | |
| NF | 8 | 20 | 5000 | 6000 | 37 | 30 | 20 | 20 | 3 | 6 | 1.0 | 1.5 | 0.1 |
| | 12 | 20 | 5000 | 6000 | 37 | 30 | 20 | 20 | 3 | 6 | 1.0 | 1.5 | 0.1 |
| | 15 | 78 | 4500 | 5400 | 47 | 37 | 26 | 30 | 3.5 | 7 | 1.5 | 1.5 | 0.3 |
| | 20 | 188 | 3000 | 3600 | 62 | 52 | 37 | 36 | 3.5 | 8 | 2.0 | 2.0 | 0.6 |
| | 25 | 250 | 2200 | 2600 | 80 | 68 | 49 | 40 | 4 | 9 | 2.5 | 2.0 | 1.1 |
| | 30 | 500 | 1800 | 2100 | 90 | 75 | 52.5 | 48 | 5 | 12 | 2.5 | 2.0 | 1.6 |
| | 35 | 663 | 1600 | 1950 | 100 | 80 | 58 | 53 | 6 | 13 | 2.5 | 2.5 | 2.3 |
| | 40 | 1100 | 1250 | 1700 | 110 | 90 | 62 | 63 | 7 | 15 | 3.0 | 2.5 | 3.1 |
| | 45 | 1500 | 1100 | 1500 | 120 | 95 | 69 | 63 | 7 | 16 | 3.0 | 2.5 | 3.7 |
| | 50 | 2375 | 850 | 1300 | 130 | 110 | 82 | 80 | 8.5 | 17 | 3.5 | 3.0 | 5.4 |
| | 55 | 2500 | 800 | 1200 | 140 | 115 | 83 | 80 | 9 | 18 | 3.5 | 3.0 | 6.1 |
| | 60 | 4250 | 700 | 1100 | 150 | 125 | 93.5 | 95 | 9 | 18 | 3.5 | 3.5 | 8.5 |
| | 70 | 5875 | 620 | 900 | 170 | 140 | 106 | 110 | 9 | 20 | 3.5 | 3.5 | 13.0 |
| | 80 | 10000 | 550 | 800 | 190 | 160 | 122 | 125 | 9 | 20 | 4.0 | 3.5 | 18.0 |
| | 90 | 17250 | 480 | 700 | 215 | 180 | 133 | 140 | 11.5 | 24 | 4.0 | 4.0 | 25.3 |
| | 100 | 19625 | 400 | 600 | 260 | 210 | 157 | 150 | 14.5 | 28 | 4.0 | 4.0 | 42.1 |
| | 130 | 34750 | 300 | 480 | 300 | 240 | 188 | 180 | 17 | 32 | 5.0 | 5.0 | 65.0 |
| 150 | 44375 | 250 | 400 | 320 | 260 | 205 | 180 | 17 | 32 | 5.0 | 5.0 | 95.0 | |

NOTES

1) $T_{max} = 2 \times T_{KN}$
 » Refer to Selection page 10 to 13

2) Inner race overruns

3) Outer race overruns

Keyway to DIN 6885.1
 » Refer to mounting and maintenance instructions
 page 16 to 19

MOUNTING EXAMPLE

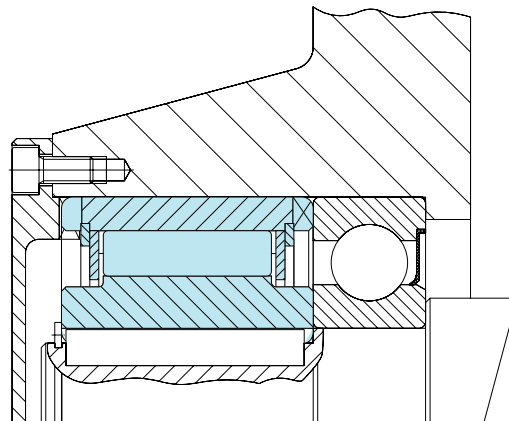

S200

TYPE



Type S200 is a non bearing supported sprag type freewheel. The sprags run directly on the shaft provided by the user. Bearings are required to support axial and radial loads. Lubrication and sealing must also be provided by the installation.

A typical arrangement is to install this type alongside a bearing as shown on the following page. The housing bore to receive the outer race will be machined with a H7 tolerance. A key will transmit the torque. The shaft on which the sprags run must have a surface hardness of

HRc 60 to 62 for a finished depth of 0,6 mm minimum. Core hardness should be HRc 35 to 45. Surface roughness must not exceed 22 CLA. Maximum shaft taper 0,01 mm per 50 mm length. Concentricity between shaft and housing bore should be maintained within TIR 0,05 mm.

The preferred lubrication is oil. The Stieber design allows the use of most of the common lubricants used in power transmission including gear oils with EP additives. When necessary grease lubrication is also possible.

S200

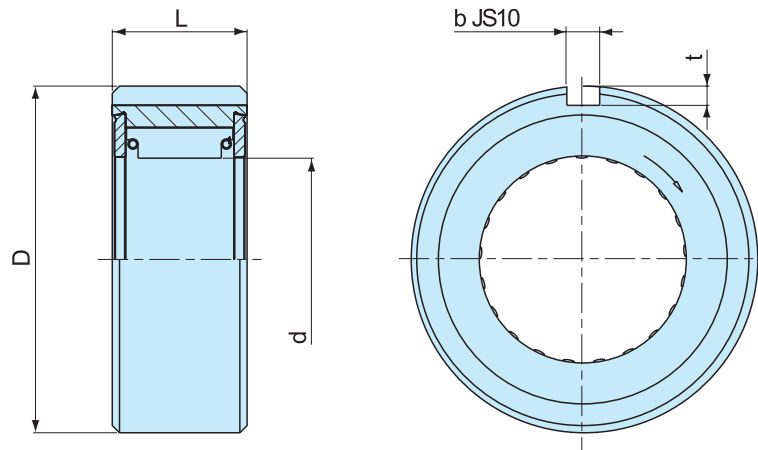

| Type | Size | d _{±0.025} [mm] | T _{KN} ¹⁾ [Nm] | Overrunning speeds | | D [mm] | L [mm] | b [mm] | t [mm] | Bearing series | Drag torque T _r [Ncm] | Weight [kg] |
|------|------|-----------------------------|---------------------------------------|--|---|---------------------------------|-----------|-----------|-----------|----------------|--|----------------|
| | | | | n _{max} ²⁾ [min ⁻¹] | n _{amax} ³⁾ [min ⁻¹] | | | | | | | |
| S200 | 203 | 16.510 | 45 | 2400 | 500 | 40 _{-0.014 -0.039} | 25 | 4 | 2.5 | 6203 | 0.01 | 0.25 |
| | 204 | 18.796 | 60 | 2400 | 500 | 47 _{-0.014 -0.039} | 25 | 5 | 3 | 6204 | 0.01 | 0.35 |
| | 205 | 23.622 | 100 | 1800 | 400 | 52 _{-0.017 -0.042} | 25 | 5 | 3 | 6205 | 0.02 | 0.45 |
| | 206 | 32.766 | 240 | 1800 | 350 | 62 _{-0.017 -0.042} | 28 | 7 | 4 | 6206 | 0.02 | 0.70 |
| | 207 | 42.088 | 380 | 1800 | 300 | 72 _{-0.017 -0.042} | 28 | 7 | 4 | 6207 | 0.02 | 0.80 |
| | 208 | 46.761 | 560 | 1800 | 200 | 80 _{-0.017 -0.042} | 32 | 10 | 4.5 | 6208 | 0.02 | 0.90 |
| | 209 | 46.761 | 560 | 1800 | 200 | 85 _{-0.020 -0.042} | 32 | 10 | 4.5 | 6209 | 0.02 | 0.95 |
| | 210 | 56.09 | 850 | 1200 | 200 | 90 _{-0.020 -0.042} | 32 | 10 | 4.5 | 6210 | 0.03 | 1.00 |

NOTES

- 1) $T_{max} = 2 \times T_{KN}$
» Refer to Selection page 10 to 13
 - 2) Inner race overruns
 - 3) Outer race overruns
- » Refer to mounting and maintenance instructions page 16 to 19

MOUNTING EXAMPLE

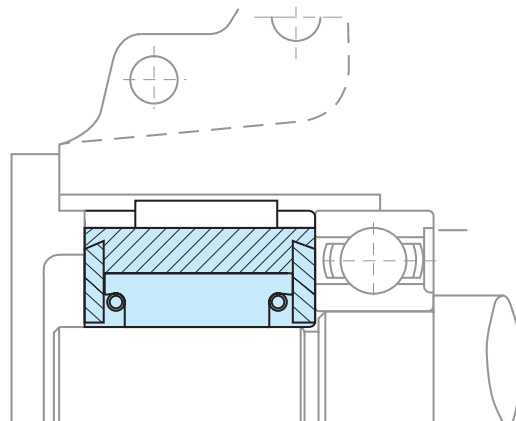

DC

TYPE



Type DC is a sprag type freewheel cage without inner or outer races. It must be installed in a design providing races, bearing support for axial and radial loads, lubrication and sealing.

The sprag space tolerance must not be exceeded. Inner and outer races must both have a minimum plain width "e", without any recess, to ensure the freewheel functions correctly as shown on following pages.

Alternatively, races can be made in case hardened steel shafts, or housings, to the specification below. Surface hardness of the finished part should be HRC 60 to 62, for a depth of 0,6 mm minimum.

Core hardness to be HRC35 to 45. Surface roughness not to exceed 22CLA. Maximum taper between races: 0,007 mm for 25 mm width.

DC

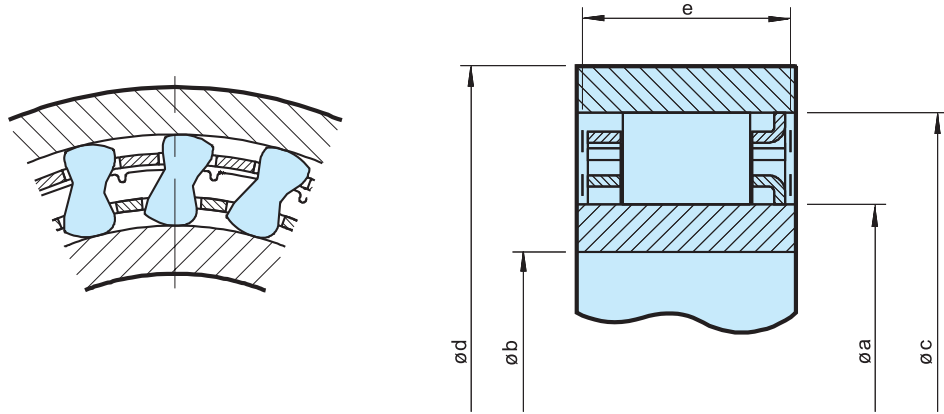

| Size | Overrunning speeds | | | Sparg space | | | Number of dips | Number of sprags | Weight | | | |
|---------------|-----------------------|---|---|---|-------------------------------------|---------------------|----------------|------------------|--------|-------------------|-------------------------------|-------------------------------|
| | $T_{KN}^{1)}$ [Nm] | $n_{imax}^{2)}$ [min ⁻¹] | $n_{amax}^{3)}$ [min ⁻¹] | $\varnothing a^{+0,008}_{-0,005}$ [mm] | $\varnothing c^{\pm 0,013}$ [mm] | Sparg space [mm] | | | | e_{min} [mm] | $\varnothing d_{min}$ [mm] | $\varnothing b_{max}$ [mm] |
| DC2222G | 63 | 8600 | 4300 | 22,225 | 38,885 | 8,33 $\pm 0,1$ | 10,0 | 50 | 15 | — | 12 | 0,030 |
| DC2776 | 119 | 6900 | 3400 | 27,762 | 44,422 | 8,33 $\pm 0,1$ | 13,5 | 58 | 18 | — | 14 | 0,055 |
| DC3034 | 124 | 6300 | 3100 | 30,340 | 47,000 | 8,33 $\pm 0,1$ | 13,5 | 62 | 20 | — | 14 | 0,060 |
| DC3175(3C) | 159 | 6000 | 3000 | 31,750 | 48,410 | 8,33 $\pm 0,1$ | 13,5 | 63 | 21 | 3 | 16 | 0,060 |
| DC3809A | 275 | 5000 | 2500 | 38,092 | 54,752 | 8,33 $\pm 0,1$ | 16,0 | 71 | 25 | — | 18 | 0,085 |
| DC4127(3C) | 224 | 4600 | 2300 | 41,275 | 57,935 | 8,33 $\pm 0,1$ | 13,5 | 75 | 27 | 3 | 18 | 0,090 |
| DC4445A | 363 | 4300 | 2100 | 44,450 | 61,110 | 8,33 $\pm 0,1$ | 16,0 | 79 | 29 | — | 20 | 0,095 |
| DC4972(4C) | 306 | 3800 | 1900 | 49,721 | 66,381 | 8,33 $\pm 0,1$ | 13,5 | 86 | 33 | 4 | 22 | 0,100 |
| DC5476A | 525 | 3500 | 1700 | 54,765 | 71,425 | 8,33 $\pm 0,1$ | 16,0 | 92 | 36 | — | 24 | 0,110 |
| DC5476A(4C) | 525 | 3500 | 1700 | 54,765 | 71,425 | 8,33 $\pm 0,1$ | 16,0 | 92 | 36 | 4 | 24 | 0,130 |
| DC5476B(4C) | 769 | 3500 | 1700 | 54,765 | 71,425 | 8,33 $\pm 0,1$ | 21,0 | 92 | 36 | 4 | 24 | 0,180 |
| DC5476C(4C) | 990 | 3500 | 1700 | 54,765 | 71,425 | 8,33 $\pm 0,1$ | 25,4 | 92 | 36 | 4 | 24 | 0,200 |
| DC5776A | 604 | 3300 | 1600 | 57,760 | 74,420 | 8,33 $\pm 0,1$ | 16,0 | 98 | 38 | — | 26 | 0,110 |
| DC6334B | 806 | 3000 | 1500 | 63,340 | 80,000 | 8,33 $\pm 0,1$ | 21,0 | 104 | 42 | — | 26 | 0,175 |
| DC7221(5C) | 675 | 2600 | 1300 | 72,217 | 88,877 | 8,33 $\pm 0,1$ | 13,5 | 115 | 48 | 5 | 30 | 0,140 |
| DC7221B | 1279 | 2600 | 1300 | 72,217 | 88,877 | 8,33 $\pm 0,1$ | 21,0 | 115 | 48 | — | 30 | 0,185 |
| DC7221B(5C) | 1279 | 2600 | 1300 | 72,217 | 88,877 | 8,33 $\pm 0,1$ | 21,0 | 115 | 48 | 5 | 30 | 0,210 |
| DC7969C(5C) | 2038 | 2400 | 1200 | 79,698 | 96,358 | 8,33 $\pm 0,1$ | 25,4 | 124 | 53 | 5 | 34 | 0,280 |
| DC8334C | 2055 | 2300 | 1100 | 83,340 | 100,000 | 8,33 $\pm 0,1$ | 25,4 | 132 | 55 | — | 34 | 0,270 |
| DC8729A | 1250 | 2200 | 1100 | 87,290 | 103,960 | 8,33 $\pm 0,1$ | 16,0 | 134 | 58 | — | 34 | 0,165 |
| DC10323A(5C)* | 1612 | 1800 | 900 | 103,231** | 119,891 | 8,33 $\pm 0,1$ | 16,0 | 155 | 68 | 5 | 40 | 0,205 |
| DC12334C* | 4800 | 1500 | 750 | 123,340** | 140,000 | 8,33 $\pm 0,1$ | 25,4 | 184 | 80 | — | 50 | 0,400 |
| DC12388C(11C) | 4875 | 1500 | 750 | 123,881 | 142,880 | 9,50 $\pm 0,1$ | 25,4 | 186 | 80 | 11 | 44 | 0,400 |

NOTES

1) $T_{max} = 2 \times T_{KN}$
» Refer to Selection page 12 to 19

2) Inner race overruns

3) Outer race overruns

*) The inner cage centering flange is on the opposite side

**) Extension of tolerance to $\pm 0,013$ permissible

Other dimensions on request

» Refer to mounting and maintenance instructions page 16 to 19

MOUNTING EXAMPLES

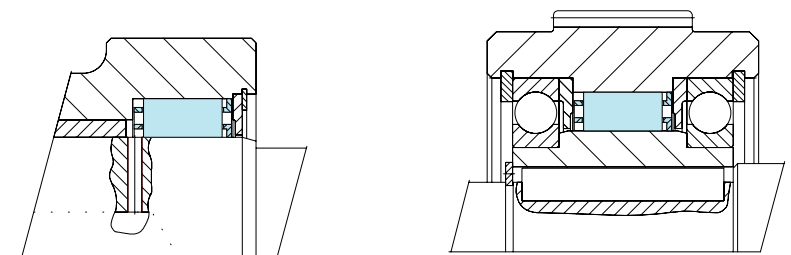

DC-RACES



TYPE



DC races are offered for use with the DC freewheel cages shown on the previous pages. The cage and race assembly, makes a non-bearing supported freewheel.

Bearing support for axial and radial loads must be provided, along with lubrication and sealing. The sprag space tolerance must not be exceeded when all bearing clearances and mounting tolerances are considered, (» see table page 43).

Taper between races should be below 0,007 mm for 25 mm width. Outer races type A and B should be pressed into housings that will not deform after assembly. Please contact our technical department if you need to transmit maximum freewheel torque capacity with A and G type. Key stresses may have to be checked.

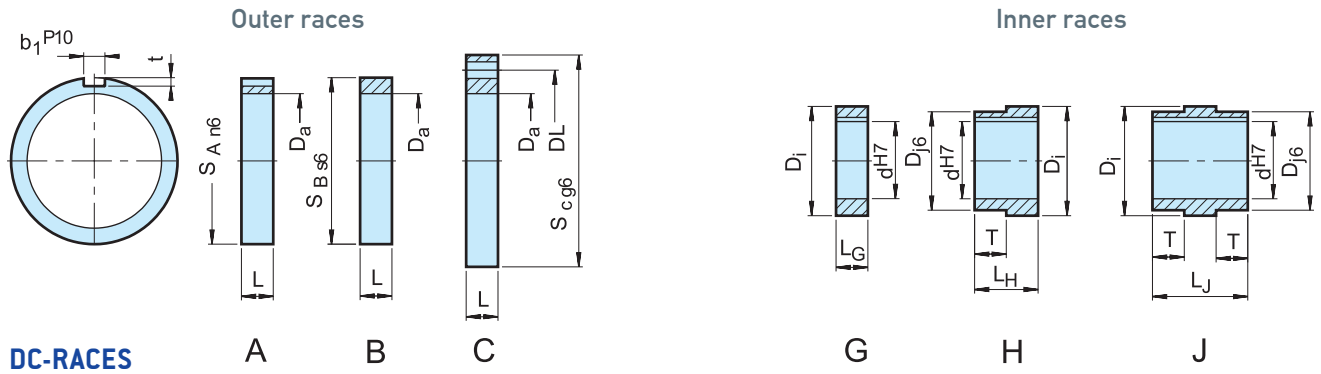

DC-RACES

1) Keyway to DIN 6885.1

| Size | | | | | | | | | | | | | | | Number of holes × ø | Corresponding DC Type | | |
|-------------|------------------|---------------|---------------|---------------|------------------|-----------|------------------------------------|-----------|-------------------|-------------|-----|------------|--------------------|------------------------|------------------------|--------------------------|--|---------|
| | d_{H7} (mm) | L_G (mm) | L_H (mm) | L_J (mm) | D_{j6} (mm) | T (mm) | $D_i^{+0.008}$ -0.005 (mm) | L (mm) | S_{An6} (mm) | b_1^{P10} | t | $S_{B s6}$ | $S_{c g6}$ (mm) | $DL_{\pm 0.1}$ (mm) | | $D_a \pm 0.013$ (mm) | | |
| DC 230A | | | | | | | | 16 | 72 | 6 | 3.5 | | | | | | | |
| DC 230B | | | | | | | | 16 | | | | 72 | | | | | | 54,752 |
| DC 230C | | | | | | | | 16 | | | | | 95 | 78 | 8 × 7 | | | 54,752 |
| DC 230 G-10 | 10 | 16 | | | | | | 38,092 | | | | | | | | | | |
| DC 230 G-15 | 15 | 16 | | | | | | 38,092 | | | | | | | | | | |
| DC 230 G-20 | 20 | 16 | | | | | | 38,092 | | | | | | | | | | |
| DC 230 H-10 | 10 | | 33 | | 35 | 17 | | 38,092 | | | | | | | | | | |
| DC 230 H-15 | 15 | | 33 | | 35 | 17 | | 38,092 | | | | | | | | | | |
| DC 230 H-20 | 20 | | 33 | | 35 | 17 | | 38,092 | | | | | | | | | | |
| DC 230 J-10 | 10 | | | 50 | 35 | 17 | | 38,092 | | | | | | | | | | |
| DC 230 J-15 | 15 | | | 50 | 35 | 17 | | 38,092 | | | | | | | | | | |
| DC 230 J-20 | 20 | | | 50 | 35 | 17 | | 38,092 | | | | | | | | | | |
| DC 167A | | | | | | | | 16 | 90 | 10 | 5 | | | | | | | 71,425 |
| DC 167B | | | | | | | | 16 | | | | 90 | | | | | | 71,425 |
| DC 167C | | | | | | | | 16 | | | | | 110 | 95 | 8 × 9 | | | 71,425 |
| DC 167G-25 | 25 | 16 | | | | | | 54,765 | | | | | | | | | | |
| DC 167G-30 | 30 | 16 | | | | | | 54,765 | | | | | | | | | | |
| DC 167G-35 | 35 | 16 | | | | | | 54,765 | | | | | | | | | | |
| DC 167H-25 | 25 | | 35 | | 50 | 19 | | 54,765 | | | | | | | | | | |
| DC 167H-30 | 30 | | 35 | | 50 | 19 | | 54,765 | | | | | | | | | | |
| DC 167H-35 | 35 | | 35 | | 50 | 19 | | 54,765 | | | | | | | | | | |
| DC 167J-25 | 25 | | | 54 | 50 | 19 | | 54,765 | | | | | | | | | | |
| DC 167J-30 | 30 | | | 54 | 50 | 19 | | 54,765 | | | | | | | | | | |
| DC 167J-35 | 35 | | | 54 | 50 | 19 | | 54,765 | | | | | | | | | | |
| DC 168A | | | | | | | | 21 | 110 | 14 | 5.5 | | | | | | | 88,877 |
| DC 168B | | | | | | | | 21 | | | | 110 | | | | | | 88,877 |
| DC 168C | | | | | | | | 21 | | | | | 140 | 120 | 8 × 11 | | | 88,877 |
| DC 168G-40 | 40 | 21 | | | | | | 72,217 | | | | | | | | | | |
| DC 168G-45 | 45 | 21 | | | | | | 72,217 | | | | | | | | | | |
| DC 168G-50 | 50 | 21 | | | | | | 72,217 | | | | | | | | | | |
| DC 168H-40 | 40 | | 42 | | 65 | 21 | | 72,217 | | | | | | | | | | |
| DC 168H-45 | 45 | | 42 | | 65 | 21 | | 72,217 | | | | | | | | | | |
| DC 168H-50 | 50 | | 42 | | 65 | 21 | | 72,217 | | | | | | | | | | |
| DC 168J-40 | 40 | | | 63 | 65 | 21 | | 72,217 | | | | | | | | | | |
| DC 168J-45 | 45 | | | 63 | 65 | 21 | | 72,217 | | | | | | | | | | |
| DC 168J-50 | 50 | | | 63 | 65 | 21 | | 72,217 | | | | | | | | | | |
| DC 235A | | | | | | | | 16 | 150 | 20 | 7.5 | | | | | | | 119,891 |
| DC 235B | | | | | | | | 16 | | | | 150 | | | | | | 119,891 |
| DC 235C | | | | | | | | 16 | | | | | 190 | 170 | 8 × 11 | | | 119,891 |
| DC 235G-55 | 55 | 16 | | | | | | 103,231 | | | | | | | | | | |
| DC 235G-60 | 60 | 16 | | | | | | 103,231 | | | | | | | | | | |
| DC 235G-75 | 75 | 16 | | | | | | 103,231 | | | | | | | | | | |
| DC 235H-55 | 55 | | 43 | | 100 | 27 | | 103,231 | | | | | | | | | | |
| DC 235H-60 | 60 | | 43 | | 100 | 27 | | 103,231 | | | | | | | | | | |
| DC 235H-75 | 75 | | 43 | | 100 | 27 | | 103,231 | | | | | | | | | | |
| DC 235J-55 | 55 | | | 70 | 100 | 27 | | 103,231 | | | | | | | | | | |
| DC 235J-60 | 60 | | | 70 | 100 | 27 | | 103,231 | | | | | | | | | | |

NFR

TYPE



Type NFR is a bearing supported roller type freewheel without any sealing. Lubrication and sealing must be provided by the installation. Standard lubrication is oil.

Size 8 to 20 units use steel on steel bearing support from the inner race. Above size 20, two 160.. series ball bearings are used, giving a higher overrunning speed capacity. A typical arrangement is shown overleaf.

The inner race is keyed to the shaft. The outer race has a positive n6 tolerance to give a press fit in a housing to H7. Additional side notches provide for positive torque transmission. The housing must be strong enough to not expand after assembly.

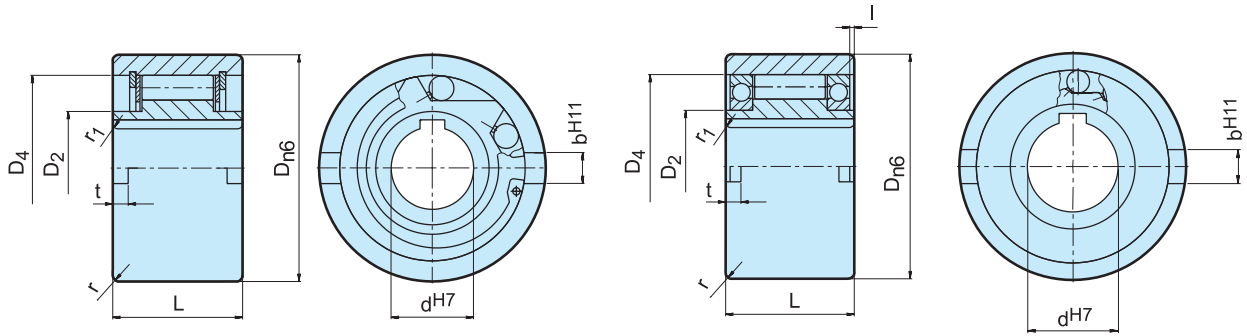

NFR 8-20*

NFR 25-130**

| Type | Size | Overrunning speeds | | | Bearing | | | | | | | | | | Weight |
|------------------|-------|-----------------------|--|---|---------|------------------|---------------|---------------|-------------|-------------|-------------|-------------------|-------------|---------------|--------|
| | | $T_{KN}^{1)}$ [Nm] | $n_{max}^{2)}$ [min ⁻¹] | $n_{omax}^{3)}$ [min ⁻¹] | | D_{n6} [mm] | D_2 [mm] | D_4 [mm] | L [mm] | l [mm] | t [mm] | b^{H11} [mm] | r [mm] | r_1 [mm] | |
| NFR (ANR-ANG) | 8 | 20 | 1000 | 1000 | * | 37 | 20 | 30 | 20 | | 3 | 6 | 1 | 1.5 | 0.1 |
| | 12 | 20 | 1000 | 1000 | * | 37 | 20 | 30 | 20 | | 3 | 6 | 1 | 1.5 | 0.1 |
| | 15 | 78 | 850 | 850 | * | 47 | 26 | 37 | 30 | | 3.5 | 7 | 1.5 | 1.5 | 0.3 |
| | 20 | 188 | 650 | 650 | * | 62 | 37 | 52 | 36 | | 3.5 | 8 | 2 | 2 | 0.6 |
| | 25 | 250 | 2100 | 3600 | 16008** | 80 | 40 | 68 | 40 | 0.2 | 4 | 9 | 2.5 | 2 | 1.2 |
| | 30 | 500 | 1700 | 3200 | 16009** | 90 | 45 | 75 | 48 | 0.2 | 5 | 12 | 2.5 | 2 | 1.8 |
| | 35 | 663 | 1550 | 3000 | 16010** | 100 | 50 | 80 | 53 | 1.2 | 6 | 13 | 2.5 | 2.5 | 2.4 |
| | 40 | 1100 | 1150 | 2600 | 16011** | 110 | 55 | 90 | 63 | 2.2 | 7 | 15 | 3 | 2.5 | 3.3 |
| | 45 | 1500 | 1000 | 2400 | 16012** | 120 | 60 | 95 | 63 | 2.2 | 7 | 16 | 3 | 2.5 | 4.0 |
| | 50 | 2375 | 800 | 2150 | 16014** | 130 | 70 | 110 | 80 | 2.7 | 8.5 | 17 | 3.5 | 3 | 5.7 |
| | 55 | 2550 | 750 | 2000 | 16015** | 140 | 75 | 115 | 80 | 4.2 | 9 | 18 | 3.5 | 3 | 6.5 |
| | 60 | 4250 | 650 | 1900 | 16016** | 150 | 80 | 125 | 95 | 3.2 | 9 | 18 | 3.5 | 3.5 | 8.9 |
| | 70 | 5875 | 550 | 1750 | 16018** | 170 | 90 | 140 | 110 | 1.1 | 9 | 20 | 3.5 | 3.5 | 13.5 |
| | 80 | 10000 | 500 | 1600 | 16021** | 190 | 105 | 160 | 125 | 0 | 9 | 20 | 4 | 3.5 | 19.0 |
| | 90 | 17250 | 450 | 1450 | 16024** | 215 | 120 | 180 | 140 | 0.6 | 11.5 | 24 | 4 | 4 | 27.2 |
| 100 | 19625 | 350 | 1250 | 16028** | 260 | 140 | 210 | 150 | 2.6 | 14.5 | 28 | 4 | 4 | 44.5 | |
| 130 | 34750 | 250 | 1000 | 16032** | 300 | 160 | 240 | 180 | 2 | 17.5 | 32 | 5 | 5 | 68.0 | |

NOTES

- 1) $T_{max} = 2 \times T_{KN}$
» Refer to Selection page 10 to 13
- 2) Inner race overruns
- 3) Outer race overruns
Keyway to DIN 6885.1
- *) With plain bearing steel on steel
- **) With 2 ball bearings series 160..
- » Refer to mounting and maintenance instructions page 16 to 19

MOUNTING EXAMPLE

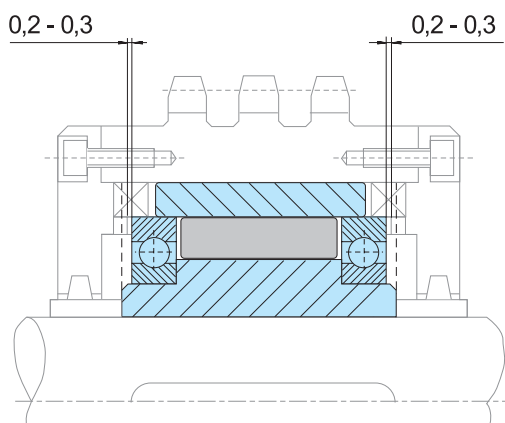

RSBW

TYPE



Type RSBW is a DC sprag type freewheel. It is self-contained, centered by plain bearings for low rotational speeds and sealed using shield protected O Rings.

Unit is delivered grease lubricated ready for installation in either a horizontal or vertical position. Primarily used as a backstop, this type provides a high torque capacity with a minimum space requirement.

The design allows installation in difficult environments such as high humidity or water splash areas. A bolt, secured to a fixed part of the machine and passing through the slot in the torque arm, provides the rotational stop. Radial clearance on this bolt should be equal to 1–3 % of the slot width. The torque arm and the bearings must not be prestressed.

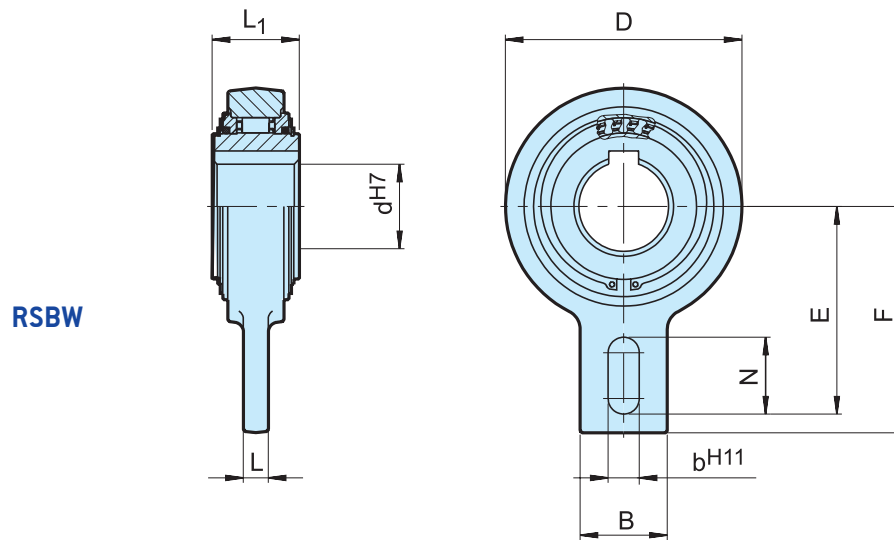

| Type | Size | Overrunning speed | | | | | | | | | | | Weight (kg) |
|------|------|-----------------------|-----------------------------------|-----------|---------------|-----------|-----------|-----------|-----------|-----------|-------------------|-----|----------------|
| | | $T_{KN}^{1)}$ (Nm) | n_{max} (min ⁻¹) | D (mm) | L_1 (mm) | F (mm) | E (mm) | B (mm) | N (mm) | L (mm) | b^{H11} (mm) | | |
| RSBW | 20 | 375 | 400 | 106 | 35 | 113 | 102,5 | 40 | 35 | 15 | 18 | 2 | |
| | 25 | 606 | 400 | 106 | 48 | 113 | 102,5 | 40 | 35 | 15 | 18 | 2,6 | |
| | 30 | 606 | 400 | 106 | 48 | 113 | 102,5 | 40 | 35 | 15 | 18 | 2,5 | |
| | 35M | 375 | 400 | 106 | 35 | 113 | 102,5 | 40 | 35 | 15 | 18 | 2 | |
| | 35 | 606 | 400 | 106 | 48 | 113 | 102,5 | 40 | 35 | 15 | 18 | 2,4 | |
| | 40 | 1295 | 300 | 132 | 52 | 125 | 115 | 60 | 35 | 15 | 18 | 4,6 | |
| | 45 | 1295 | 300 | 132 | 52 | 125 | 115 | 60 | 35 | 15 | 18 | 4,5 | |
| | 50 | 1295 | 300 | 132 | 52 | 125 | 115 | 60 | 35 | 15 | 18 | 4,5 | |
| | 55 | 1295 | 300 | 132 | 52 | 125 | 115 | 60 | 35 | 15 | 18 | 4,4 | |
| | 60 | 2550 | 250 | 161 | 54 | 140 | 130 | 70 | 35 | 15 | 18 | 6,5 | |
| | 70 | 2550 | 250 | 161 | 54 | 140 | 130 | 70 | 35 | 15 | 18 | 6,4 | |
| | 80 | 4875 | 200 | 190 | 70 | 165 | 150 | 70 | 45 | 20 | 25 | 9,9 | |
| | 90 | 4875 | 200 | 190 | 70 | 165 | 150 | 70 | 45 | 20 | 25 | 9,8 | |

NOTES

- 1) $T_{max} = 2 \times T_{KN}$
 » Refer to Selection page 10 to 13

Keyway to DIN 6885.1

- » Refer to mounting and maintenance instructions
 page 16 to 19

MOUNTING EXAMPLE

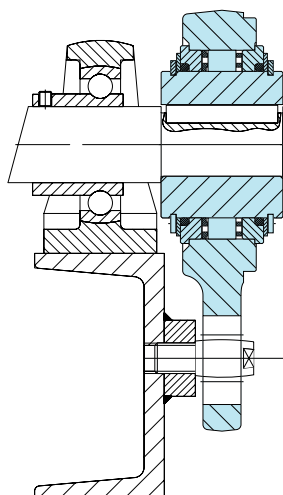

AV

TYPE



Type AV is a roller type freewheel. It is self-contained, centered by plain bearings for low rotational speeds, and sealed using shield protected metallic labyrinth seals

Unit is delivered grease lubricated, ready to install in a horizontal or vertical position. Primarily used as a backstop, the torque capacity is high for a minimum space requirement. This design is suitable for use in difficult environments. A bolt, secured to a fixed part of the

machine and passing through the slot in the torque arm, provides the rotational stop. Radial clearance on this bolt should be equal to 1–3 % of the slot width.

The torque arm and the bearings must not be prestressed. The roller design makes the AV type ideal for light indexing applications.

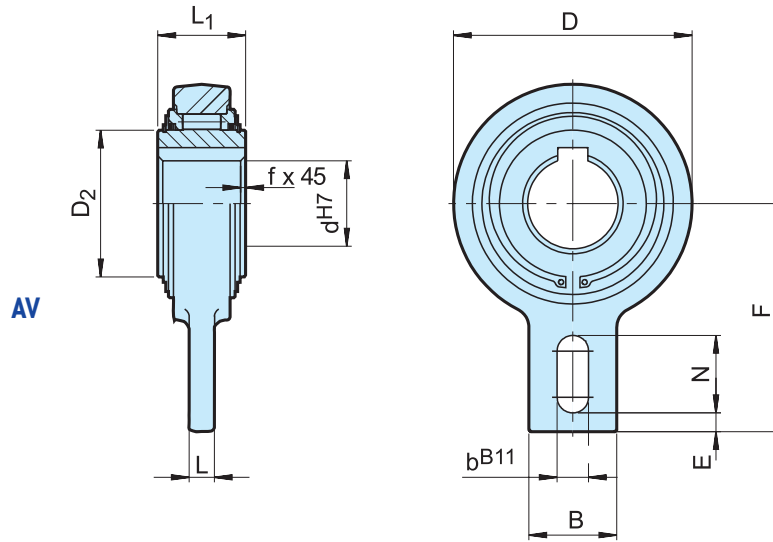

| Type | Size | Overrunning speed | | | | | | | | | | | Weight | Drag torque | |
|------|------|-------------------|-----------------------|-----------------------------------|-----------|------------------------|------------------------|-----------|-----------|-----------|--------------------------|-----------|--------|-------------|-----------|
| | | d^{H7} [mm] | $T_{KN}^{1)}$ [Nm] | n_{max} [min ⁻¹] | D [mm] | D ₂ [mm] | L ₁ [mm] | L [mm] | B [mm] | F [mm] | b ^{B11} [mm] | N [mm] | | | E [mm] |
| AV | 20 | 265 | 450 | 83 | 42 | 35 | 12 | 40 | 90 | 15 | 35 | 5 | 0,8 | 1,3 | 18 |
| | 25 | 265 | 450 | 83 | 42 | 35 | 12 | 40 | 90 | 15 | 35 | 5 | 0,8 | 1,3 | 18 |
| | 30 | 1200 | 320 | 118 | 60 | 54 | 15 | 40 | 110 | 15 | 35 | 8 | 1 | 3,5 | 130 |
| | 35 | 1200 | 320 | 118 | 60 | 54 | 15 | 40 | 110 | 15 | 35 | 8 | 1 | 3,4 | 130 |
| | 40 | 1200 | 320 | 118 | 60 | 54 | 15 | 40 | 110 | 15 | 35 | 8 | 1 | 3,3 | 130 |
| | 45 | 2150 | 280 | 155 | 90 | 54 | 20 | 80 | 140 | 18 | 47 | 10 | 1 | 5,5 | 240 |
| | 50 | 2150 | 280 | 155 | 90 | 54 | 20 | 80 | 140 | 18 | 47 | 10 | 1 | 5,4 | 240 |
| | 55 | 2150 | 280 | 155 | 90 | 54 | 20 | 80 | 140 | 18 | 47 | 10 | 1 | 5,3 | 240 |
| | 60 | 2150 | 280 | 155 | 90 | 54 | 20 | 80 | 140 | 18 | 47 | 10 | 1 | 5,2 | 240 |
| | 70 | 2150 | 280 | 155 | 90 | 54 | 20 | 80 | 140 | 18 | 47 | 10 | 1 | 5,0 | 240 |
| | 80 | 2900 | 200 | 190 | 110 | 64 | 20 | 80 | 155 | 20 | 40 | 10 | 1,5 | 8,7 | 360 |
| | 90* | 7125 | 150 | 260 | 160 | 90 | 25 | 120 | 220 | - | - | - | 3 | 24,5 | 360 |
| | 100* | 7125 | 150 | 260 | 160 | 90 | 25 | 120 | 220 | - | - | - | 3 | 23,5 | 360 |
| | 110* | 7125 | 150 | 260 | 160 | 90 | 25 | 120 | 220 | - | - | - | 3 | 22,5 | 360 |
| | 120* | 11000 | 130 | 300 | 180 | 110 | 30 | 140 | 260 | - | - | - | 3 | 42 | 600 |

NOTES

1) $T_{max} = 2 \times T_{KN}$
 » Refer to Selection page 10 to 13
 Keyway to DIN 6885.1

*) 2 Keyways 120° offset

» Refer to mounting and maintenance instructions
 page 16 to 19

MOUNTING EXAMPLE

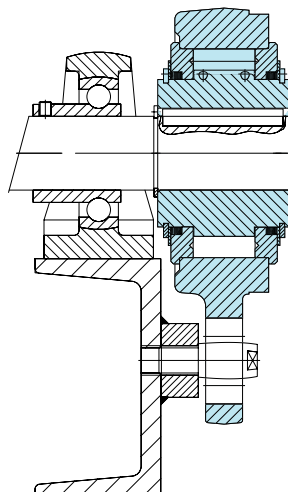

AL ALP



TYPE



AL

ALP

Types AL, ALP are roller type freewheels. These units are part of the Stieber modular system. They are bearing supported, using two 160.. series bearings, and require oil lubrication. These units may be used in designs providing oil lubrication and sealing as on the example overleaf.

The bearings must not be axially stressed. Typically, types AL, ALP are used with standard covers that are designed to transmit torque, and provide oil lubrication

and sealing. Usually these covers are used in pairs according to combinations shown on the following pages. The outer race of the AL model is plain to receive and center any component bored to H7 tolerance. Torque is transmitted by bolts through the cover plate in this case. Types AL, ALP are identical except that type ALP has a keyway on the outside diameter to transmit the torque. Two paper seals are delivered with each unit to be placed between the outer race and cover plates.

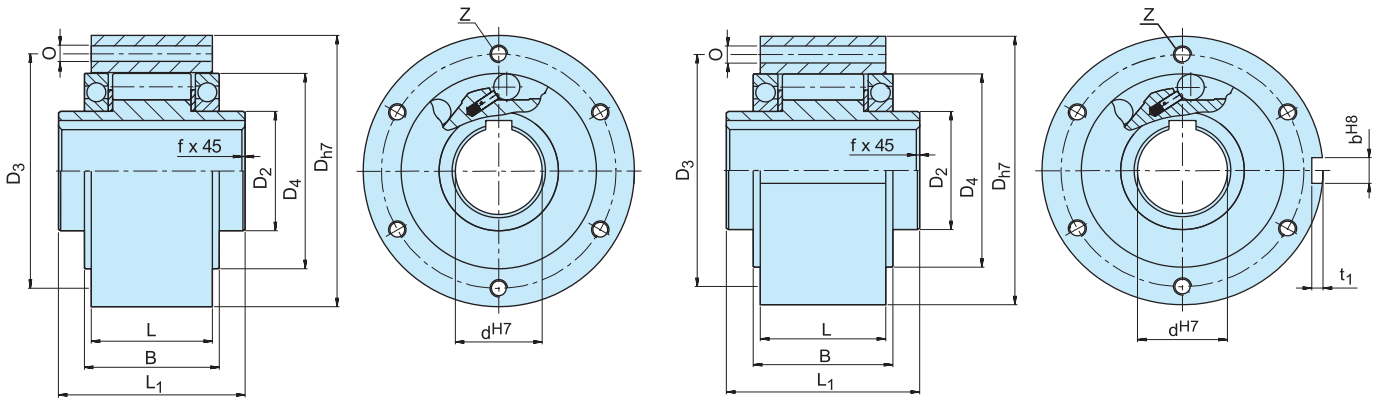

AL

ALP

| Type | Size | Overrunning speeds | | | | Number | | | | | | | | | | | Weight | Drag torque |
|-----------|--------|-----------------------|---|---|------------------|---------------|---------------|---------------|-----|-----|---------------|----------------|-------------|---------------|------------------|-------------|--------|-------------|
| | | $T_{KN}^{1)}$ [Nm] | $n_{imax}^{2)}$ [min ⁻¹] | $n_{amax}^{3)}$ [min ⁻¹] | D_{h7} [mm] | D_2 [mm] | D_4 [mm] | D_3 [mm] | 0 | z | L^1 [mm] | $L^4)$ [mm] | B [mm] | t_1 [mm] | b^{H8} [mm] | f [mm] | | |
| AL ALP | 12 | 55 | 4000 | 7200 | 62 | 20 | 42 | 51 | 5,5 | 3 | 42 | 20,3 | 27 | 2,4 | 4 | 0,5 | 0,5 | 3,4 |
| | 15 | 125 | 3600 | 6500 | 68 | 25 | 47 | 56 | 5,5 | 3 | 52 | 30,3 | 34,1 | 2,9 | 5 | 0,8 | 0,8 | 4,1 |
| | 20 | 181 | 2700 | 5600 | 75 | 30 | 55 | 64 | 5,5 | 4 | 57 | 34,3 | 39,1 | 3,5 | 6 | 0,8 | 1,0 | 8 |
| | 25 | 288 | 2100 | 4500 | 90 | 40 | 68 | 78 | 5,5 | 6 | 60 | 37,3 | 42,1 | 4,1 | 8 | 1,0 | 1,5 | 14 |
| | 30 | 500 | 1700 | 4100 | 100 | 45 | 75 | 87 | 6,6 | 6 | 68 | 44,3 | 49,1 | 4,1 | 8 | 1,0 | 2,2 | 23 |
| | 35 | 725 | 1550 | 3800 | 110 | 50 | 80 | 96 | 6,6 | 6 | 74 | 48,3 | 54,1 | 4,7 | 10 | 1,0 | 3,0 | 60 |
| | 40 | 1025 | 1150 | 3400 | 125 | 55 | 90 | 108 | 9 | 6 | 86 | 56,3 | 62,1 | 4,9 | 12 | 1,5 | 4,6 | 72 |
| | 45 | 1125 | 1000 | 3200 | 130 | 60 | 95 | 112 | 9 | 8 | 86 | 56,3 | 62,1 | 5,5 | 14 | 1,5 | 4,7 | 140 |
| | 50 | 2125 | 800 | 2800 | 150 | 70 | 110 | 132 | 9 | 8 | 92 | 63,3 | 69,1 | 5,5 | 14 | 1,5 | 7,2 | 180 |
| | 55 | 2625 | 750 | 2650 | 160 | 75 | 115 | 138 | 11 | 8 | 104 | 67 | 73,1 | 6,2 | 16 | 2,0 | 8,6 | 190 |
| | 60 | 3500 | 650 | 2450 | 170 | 80 | 125 | 150 | 11 | 10 | 114 | 78 | 84 | 6,8 | 18 | 2,0 | 10,5 | 240 |
| | 70 | 5750 | 550 | 2150 | 190 | 90 | 140 | 165 | 11 | 10 | 134 | 95 | 103 | 7,4 | 20 | 2,5 | 13,5 | 320 |
| | 80 | 8500 | 500 | 1900 | 210 | 105 | 160 | 185 | 11 | 10 | 144 | 100 | 108 | 8,5 | 22 | 2,5 | 18,2 | 330 |
| | 90 | 14500 | 450 | 1700 | 230 | 120 | 180 | 206 | 14 | 10 | 158 | 115 | 125 | 8,7 | 25 | 3,0 | 28,5 | 650 |
| | 100 | 20000 | 350 | 1450 | 270 | 140 | 210 | 240 | 18 | 10 | 182 | 120 | 131 | 9,9 | 28 | 3,0 | 42,5 | 830 |
| | 120 | 31250 | 250 | 1250 | 310 | 160 | 240 | 278 | 18 | 12 | 202 | 140 | 152 | 11,1 | 32 | 3,0 | 65,0 | 1080 |
| 150 | 70000 | 200 | 980 | 400 | 200 | 310 | 360 | 22 | 12 | 246 | 180 | 196 | 12,3 | 36 | 4,0 | 138,0 | 1240 | |
| 200 | 175000 | 150 | 750 | 520 | 260 | 400 | 460 | 26 | 18 | 326 | 240 | 265 | 15 | 45 | 5,0 | 315,0 | 3800 | |
| 250 | 287500 | 120 | 620 | 610 | 320 | 480 | 545 | 33 | 20 | 396 | 300 | 330 | 15 | 45 | 5,0 | 512,0 | 6100 | |
| ALM | 25 | 388 | 2100 | 2800 | 90 | 40 | 68 | 78 | 5,5 | 6 | 60 | 37,3 | 42,1 | 4,1 | 8 | 1,0 | 1,7 | 22 |
| | 30 | 588 | 1700 | 2500 | 100 | 45 | 75 | 87 | 6,6 | 6 | 68 | 44,3 | 49,1 | 4,1 | 8 | 1,0 | 2,5 | 37 |
| | 35 | 838 | 1550 | 2400 | 110 | 50 | 80 | 96 | 6,6 | 6 | 74 | 48,3 | 54,1 | 4,7 | 10 | 1,0 | 3,2 | 66 |

NOTES

- 1) $T_{max} = 2 \times T_{KN}$
» Refer to Selection page 10 to 13
 - 2) Inner race overruns, values without lip seals
 - 3) Outer race overruns
Keyway to DIN 6885.1
 - 4) The dimension L includes up to size 50 the each 0.25 mm thick paper seals to be located on both faces
- » Refer to mounting and maintenance instructions page 16 to 19

MOUNTING EXAMPLE

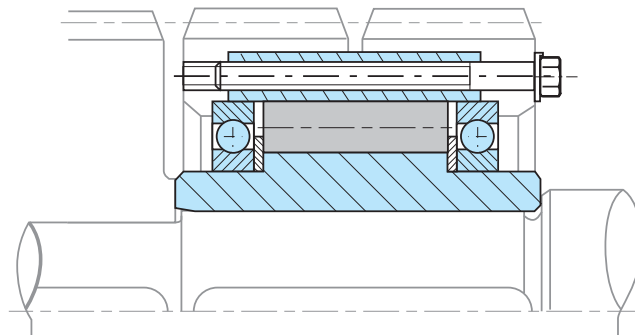

AL..F2D2 AL..F4D2



TYPE



AL..F2D2

AL..F4D2

Types AL..F2D2/F4D2 are roller type freewheels, self-contained, sealed and bearing supported, using two 160.. series bearings. Units are delivered oil lubricated.

Primarily used as overrunning or indexing clutches, the cover combination is chosen according to the type of drive, as shown overleaf. D2 cover is used to close the unit.

It is equipped with two screws for oil filling, drain and level. The shaft seal is a V-ring type. Cover and seal have been designed to be oil proof with minimum drag torque.

We recommend the unit is supplied assembled. Please specify inner race direction of rotation seen from the D2 flange.

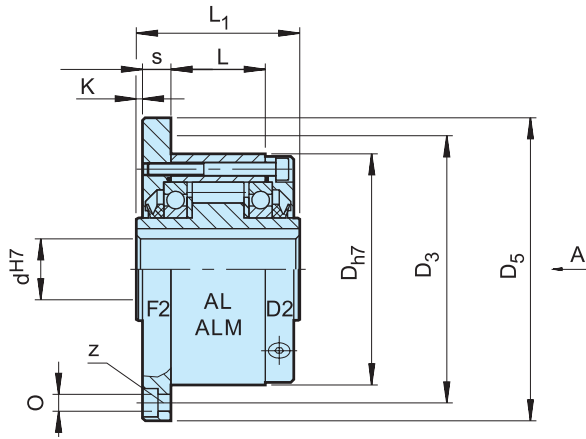

AL..F2D2

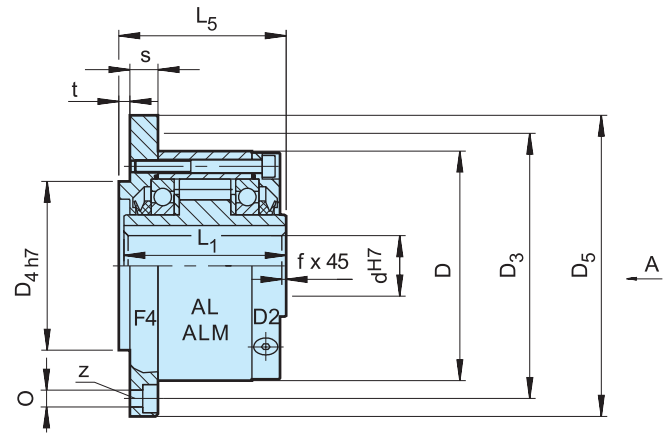

AL..F4D2

| Type | Size | Overrunning speeds | | | | | | | | | | | | | | | Weight | Drag torque |
|------------------------|--------|--------------------|----------------------|----------------------|------------------|----------|-------|-------|-------|------|------|-----------|-------|-------|------|------|--------|-------------|
| | | $d_{H7}^{(1)}$ | $T_{KN}^{(1)}$ | $n_{imax}^{(2)}$ | $n_{amax}^{(3)}$ | D_{h7} | L_1 | D_5 | D_3 | z | O | D_{4h7} | t | L_5 | K | s | | |
| | [mm] | [Nm] | [min ⁻¹] | [min ⁻¹] | [mm] | [mm] | [mm] | [mm] | | [mm] | [mm] | [mm] | [mm] | [mm] | [mm] | [mm] | [kg] | [Ncm] |
| AL..F2D2 AL..F4D2 | 12 | 55 | 2500 | 7200 | 62 | 42 | 85 | 72 | 3 | 5,5 | 42 | 3 | 44 | 0,5 | 10,3 | 0,5 | 0,9 | 11 |
| | 15 | 125 | 1900 | 6500 | 68 | 52 | 92 | 78 | 3 | 5,5 | 47 | 3 | 54 | 0,5 | 10,3 | 0,8 | 1,3 | 15 |
| | 20 | 181 | 1600 | 5600 | 75 | 57 | 98 | 85 | 4 | 5,5 | 55 | 3 | 59 | 0,5 | 10,8 | 0,8 | 1,7 | 18 |
| | 25 | 288 | 1400 | 4500 | 90 | 60 | 118 | 104 | 4 | 6,6 | 68 | 3 | 62 | 0,5 | 10,5 | 1 | 2,6 | 36 |
| | 30 | 500 | 1300 | 4100 | 100 | 68 | 128 | 114 | 6 | 6,6 | 75 | 3 | 70 | 0,5 | 11,3 | 1 | 3,5 | 4 |
| | 35 | 725 | 1100 | 3800 | 110 | 74 | 138 | 124 | 6 | 6,6 | 80 | 3,5 | 76 | 1 | 11,8 | 1 | 4,5 | 60 |
| | 40 | 1025 | 950 | 3400 | 125 | 86 | 160 | 142 | 6 | 9 | 90 | 3,5 | 88 | 1 | 13,8 | 1,5 | 6,9 | 84 |
| | 45 | 1125 | 900 | 3200 | 130 | 86 | 165 | 146 | 8 | 9 | 95 | 3,5 | 88 | 1 | 13,8 | 1,5 | 7,1 | 94 |
| | 50 | 2125 | 850 | 2800 | 150 | 92 | 185 | 166 | 8 | 9 | 110 | 4 | 94 | 1 | 12,8 | 1,5 | 10,1 | 128 |
| | 55 | 2625 | 720 | 2650 | 160 | 104 | 204 | 182 | 8 | 11 | 115 | 4 | 106 | 1,5 | 16,8 | 2 | 13,1 | 150 |
| | 60 | 3500 | 680 | 2450 | 170 | 114 | 214 | 192 | 10 | 11 | 125 | 4 | 116 | 1,5 | 16,3 | 2 | 15,6 | 160 |
| | 70 | 5750 | 580 | 2150 | 190 | 134 | 234 | 212 | 10 | 11 | 140 | 4 | 136 | 1,5 | 17,8 | 2,5 | 20,4 | 360 |
| | 80 | 8500 | 480 | 1900 | 210 | 144 | 254 | 232 | 10 | 11 | 160 | 4 | 146,3 | 1,5 | 20,3 | 2,5 | 26,7 | 360 |
| | 90 | 14500 | 380 | 1700 | 230 | 158 | 278 | 254 | 10 | 14 | 180 | 4,5 | 161 | 1,5 | 20 | 3 | 39 | 680 |
| | 100 | 20000 | 350 | 1450 | 270 | 182 | 335 | 305 | 10 | 18 | 210 | 5 | 184 | 2,5 | 28 | 3 | 66 | 880 |
| | 120 | 31250 | 250 | 1250 | 310 | 202 | 375 | 345 | 12 | 18 | 240 | 5 | 204 | 2,5 | 28,5 | 3 | 91 | 1200 |
| | 150 | 70000 | 180 | 980 | 400 | 246 | 485 | 445 | 12 | 22 | 310 | 5 | 249 | 2,5 | 31 | 4 | 186 | 1350 |
| 200 | 175000 | 120 | 750 | 520 | 326 | 625 | 565 | 18 | 26 | 400 | 5 | 328 | 3 | 40 | 5 | 425 | 4200 | |
| 250 | 287500 | 100 | 620 | 610 | 396 | 740 | 680 | 20 | 33 | 480 | 5 | 398 | 3 | 45 | 5 | 680 | 6500 | |
| ALM..F2D2 ALM..F4D2 | 25 | 388 | 1100 | 2800 | 90 | 60 | 118 | 104 | 4 | 6,6 | 68 | 3 | 62 | 0,5 | 10,5 | 1 | 2,7 | 41 |
| | 30 | 588 | 1000 | 2500 | 100 | 68 | 128 | 114 | 6 | 6,6 | 75 | 3 | 70 | 0,5 | 11,3 | 1 | 3,65 | 64 |
| | 35 | 838 | 900 | 2400 | 110 | 74 | 138 | 124 | 6 | 6,6 | 80 | 3,5 | 76 | 1 | 11,8 | 1 | 4,7 | 76 |

NOTES

1) $T_{max} = 2 \times T_{KN}$
» Refer to Selection page 10 to 13

2) Inner race overruns

3) Outer race overruns
Keyway to DIN 6885.1

When ordering, please specify direction of rotation seen from arrow

A": „R“ Inner race overruns in clockwise direction..L“ Inner race overruns in counterclockwise

» Refer to mounting and maintenance instructions page 16 to 19

MOUNTING EXAMPLE

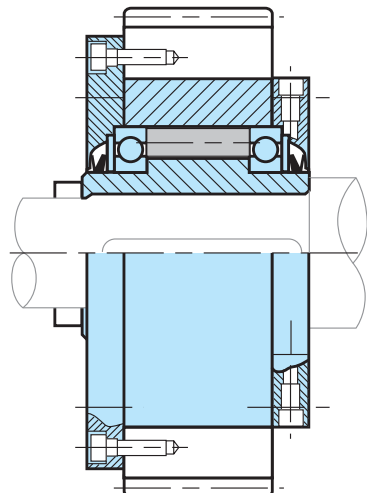

ALP..F7D7 ALMP..F7D7



TYPE



Type ALP..F7D7 is a roller type freewheel, self-contained, sealed and bearing supported using two 160.. series bearings. Unit is not delivered oil lubricated.

This cover combination is mostly used as an overrunning or indexing clutch as shown overleaf. A keyway is machined on the outer race for the connection to the drive or driven member centered on its outside.

D7 cover is used to close the unit. It is equipped with two screws for oil filling, drain and level. The shaft seal is a V-ring type. Cover and seal have been designed to be oil proof with minimum drag torque.

ALP..F7D7

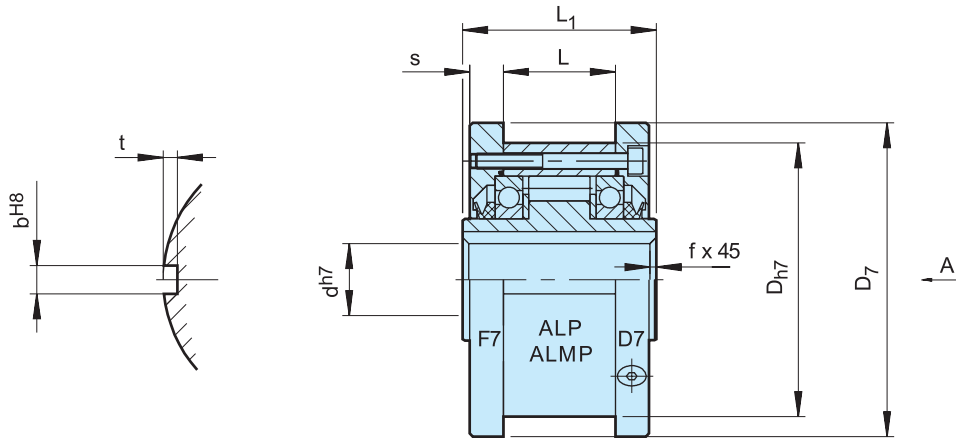

| Type | Size | Overrunning speeds ⁿ | | | | | | | | | | | Weight | Drag torque |
|-----------|--------|---------------------------------|-----------------------|---|---|------------------|---------------|---------------|-------------|-------------|------------------|-------------|--------|-------------|
| | | $d_{h7}^{1)}$ [mm] | $T_{KN}^{2)}$ [Nm] | $n_{imax}^{3)}$ [min ⁻¹] | $n_{amax}^{3)}$ [min ⁻¹] | D_{h7} [mm] | L_1 [mm] | D_7 [mm] | s [mm] | L [mm] | b^{H8} [mm] | t [mm] | | |
| ALP..F7D7 | 12 | 55 | 2500 | 7200 | 62 | 42 | 70 | 10,4 | 20 | 4 | 2,4 | 0,5 | 1,0 | 11 |
| | 15 | 125 | 1900 | 6500 | 68 | 52 | 76 | 11,4 | 28 | 5 | 2,9 | 0,8 | 1,4 | 15 |
| | 20 | 181 | 1600 | 5600 | 75 | 57 | 84 | 10,9 | 34 | 6 | 3,5 | 0,8 | 1,9 | 18 |
| | 25 | 288 | 1400 | 4500 | 90 | 60 | 99 | 11,9 | 35 | 8 | 4,1 | 1 | 2,8 | 36 |
| | 30 | 500 | 1300 | 4100 | 100 | 68 | 109 | 11,9 | 43 | 8 | 4,1 | 1 | 3,7 | 45 |
| | 35 | 725 | 1100 | 3800 | 110 | 74 | 119 | 13,4 | 45 | 10 | 4,7 | 1 | 4,7 | 60 |
| | 40 | 1025 | 950 | 3400 | 125 | 86 | 135 | 15,4 | 53 | 12 | 4,9 | 1,5 | 7,1 | 84 |
| | 45 | 1125 | 900 | 3200 | 130 | 86 | 140 | 15,4 | 53 | 14 | 5,5 | 1,5 | 7,4 | 94 |
| | 50 | 2125 | 850 | 2800 | 150 | 92 | 160 | 12,9 | 64 | 14 | 5,5 | 1,5 | 10,4 | 128 |
| | 55 | 2625 | 720 | 2650 | 160 | 104 | 170 | 17,5 | 66 | 16 | 6,2 | 2 | 13,4 | 150 |
| | 60 | 3500 | 680 | 2450 | 170 | 114 | 182 | 16,5 | 78 | 18 | 6,8 | 2 | 15,9 | 160 |
| | 70 | 5750 | 580 | 2150 | 190 | 134 | 202 | 18 | 95 | 20 | 7,4 | 2,5 | 20,8 | 360 |
| | 80 | 8500 | 480 | 1900 | 210 | 144 | 222 | 20,5 | 100 | 22 | 8,5 | 2,5 | 27,1 | 360 |
| | 90 | 14500 | 380 | 1700 | 230 | 158 | 242 | 20 | 115 | 25 | 8,7 | 3 | 39,4 | 680 |
| | 100 | 20000 | 350 | 1450 | 270 | 182 | 282 | 28,5 | 120 | 28 | 9,9 | 3 | 66,4 | 880 |
| | 120 | 31250 | 250 | 1250 | 310 | 202 | 322 | 22,5 | 152 | 32 | 11,1 | 3 | 91,5 | 1200 |
| | 150 | 70000 | 180 | 980 | 400 | 246 | 412 | 31 | 180 | 36 | 12,3 | 4 | 187 | 1350 |
| 200 | 175000 | 120 | 750 | 520 | 326 | 540 | 40 | 240 | 45 | 15 | 5 | 430 | 4200 | |
| 250 | 287500 | 100 | 620 | 610 | 396 | 630 | 45 | 300 | 45 | 15 | 5 | 688 | 6500 | |
| ALMP F7D7 | 25 | 388 | 1100 | 2800 | 90 | 60 | 99 | 11,9 | 35 | 8 | 4,1 | 1 | 2,9 | 41 |
| | 30 | 588 | 1000 | 2500 | 100 | 68 | 109 | 11,9 | 43 | 8 | 4,1 | 1 | 3,85 | 64 |
| | 35 | 838 | 900 | 2400 | 110 | 74 | 119 | 13,4 | 45 | 10 | 4,7 | 1 | 4,9 | 76 |

NOTES

1) $T_{max} = 2 \times T_{KN}$
» Refer to Selection page 10 to 13

2) Inner race overruns

3) Outer race overruns

Keyway to DIN 6885.1

When ordering, please specify direction of rotation seen from arrow „A“: „R“ Inner race overruns in clockwise direction, „L“ Inner race overruns in counterclockwise direction

» Refer to mounting and maintenance instructions page 16 to 19

MOUNTING EXAMPLE

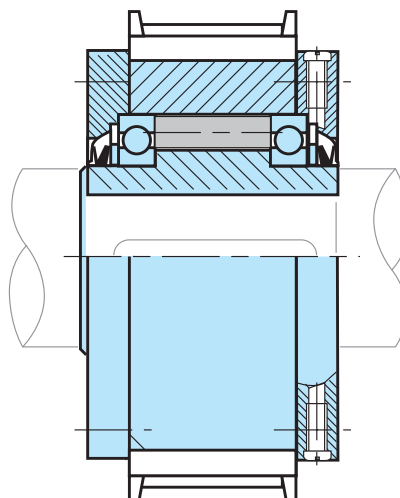

AL..KEED2



TYPE



Type AL..KEED2 is a roller type freewheel, self-contained, sealed and bearing supported, using two 160.. series bearings. Unit is delivered oil lubricated.

This combination is used as overrunning clutch as shown overleaf. In this design, a standard AL freewheel is connected to a flexible coupling for in-line mounting.

The KEE type is a high performance coupling used to damp torsional vibrations and to accept misalignment

without excess bearing loads. D2 cover is used to close the unit. It is equipped with two screws for oil filling, drain and level. We recommend the unit is supplied assembled. Please specify inner race direction of rotation seen from the D2 flange. Refer to manufacturer's catalogue to check coupling selection.

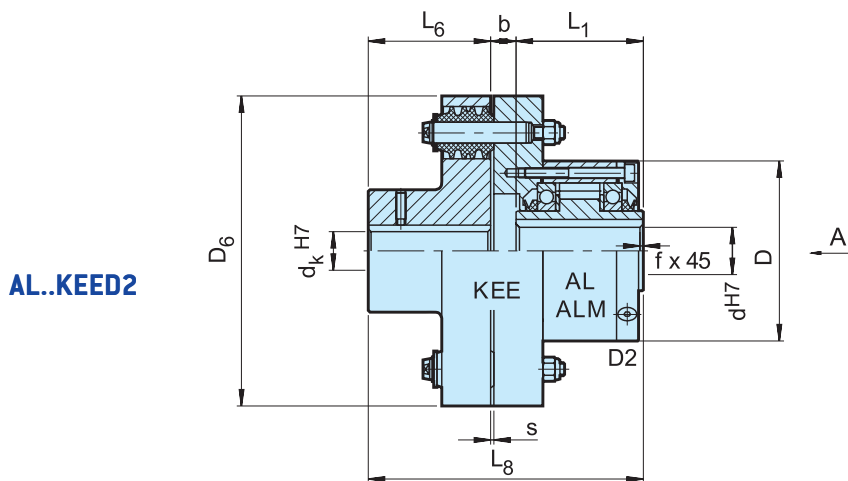

| Type | Size | Overrunning speeds | | | | | | | | | | | Weight | | |
|------------|------|--------------------|------------------|---|---|--------------------|-----------|---------------|---------------|---------------|---------------|-----------|--------|-----------|-----------|
| | | KEE | T_{KN} [Nm] | $n_{imax}^{1)}$ [min ⁻¹] | $n_{amax}^{2)}$ [min ⁻¹] | d_k^{H7} [mm] | D [mm] | L_1 [mm] | D_6 [mm] | L_6 [mm] | L_8 [mm] | b [mm] | | s [mm] | f [mm] |
| AL..KEED2 | 12 | 2 | 55 | 2500 | 6000 | 12...25 | 62 | 42 | 97 | 35 | 90 | 13 | 3 | 0,5 | 3 |
| | 15 | 3 | 122 | 1900 | 6000 | 16...30 | 68 | 52 | 112 | 40 | 110 | 18 | 3 | 0,8 | 4,4 |
| | 20 | 3 | 122 | 1600 | 5600 | 16...30 | 75 | 57 | 112 | 40 | 114,5 | 17,5 | 3 | 0,8 | 4,6 |
| | 25 | 4 | 288 | 1400 | 4500 | 20...40 | 90 | 60 | 130 | 50 | 127,5 | 17,5 | 3 | 1 | 6,4 |
| | 30 | 5 | 500 | 1300 | 4100 | 20...50 | 100 | 68 | 160 | 60 | 148 | 20 | 2 | 1 | 11 |
| | 35 | 6 | 725 | 1100 | 3800 | 25...65 | 110 | 74 | 190 | 75 | 168 | 19 | 2 | 1 | 17 |
| | 40 | 6 | 1025 | 950 | 3400 | 25...65 | 125 | 86 | 190 | 75 | 178 | 17 | 2 | 1,5 | 19 |
| | 45 | 6 | 1050 | 900 | 3200 | 25...65 | 130 | 86 | 190 | 75 | 178 | 17 | 2 | 1,5 | 19 |
| | 50 | 7 | 1750 | 850 | 2800 | 30...75 | 150 | 92 | 225 | 90 | 207 | 25 | 2,5 | 1,5 | 31 |
| | 55 | 8 | 2625 | 720 | 2650 | 35...90 | 160 | 104 | 270 | 100 | 233,5 | 29,5 | 3 | 2 | 47 |
| | 60 | 8 | 2750 | 680 | 2450 | 35...90 | 170 | 114 | 270 | 100 | 244 | 30 | 3 | 2 | 49 |
| | 70 | 10 | 5750 | 580 | 2150 | 45...110 | 190 | 134 | 340 | 140 | 312,5 | 38,5 | 3 | 2,5 | 90 |
| | 80 | 11 | 8500 | 480 | 1900 | 55...125 | 210 | 144 | 380 | 160 | 340 | 36 | 3 | 2,5 | 107 |
| | 90 | 12 | 13750 | 380 | 1700 | 65...140 | 230 | 158 | 440 | 180 | 388 | 50 | 3,5 | 3 | 170 |
| | 100 | 14 | 20000 | 350 | 1450 | 75...160 | 270 | 182 | 500 | 200 | 422,5 | 40,5 | 3,5 | 3 | 230 |
| | 120 | 16 | 30000 | 250 | 1250 | 85...180 | 310 | 202 | 560 | 220 | 471 | 49 | 4 | 3 | 330 |
| | 150 | 18 | 43750 | 180 | 980 | 95...200 | 400 | 246 | 640 | 250 | 543 | 47 | 4 | 4 | 500 |
| 200 | 22 | 97500 | 120 | 750 | 125...250 | 520 | 326 | 880 | 320 | 700,5 | 54,5 | 4,5 | 5 | 965 | |
| 250 | 28 | 250000 | 100 | 620 | 160...320 | 610 | 396 | 1160 | 400 | 868 | 72 | 5 | 5 | 1725 | |
| ALM..KEED2 | 25 | 4 | 288 | 1100 | 2800 | 20...40 | 90 | 60 | 130 | 50 | 127,5 | 17,5 | 3 | 1 | 6,4 |
| | 30 | 5 | 588 | 1000 | 2500 | 20...50 | 100 | 68 | 160 | 60 | 148 | 20 | 2 | 1 | 11 |
| | 35 | 6 | 838 | 900 | 2400 | 25...65 | 110 | 74 | 190 | 75 | 168 | 19 | 2 | 1 | 17 |

NOTES

1) Inner race overrun

2) Outer race overruns

Keyway to DIN 6885.1

When ordering, please specify bore $\varnothing d_k$ and direction of rotation seen from arrow „A“: „R“ Inner race overruns in clockwise direction, „L“ Inner race overruns in counter-clockwise direction

» Refer to mounting and maintenance instructions page 16 to 19

MOUNTING EXAMPLE

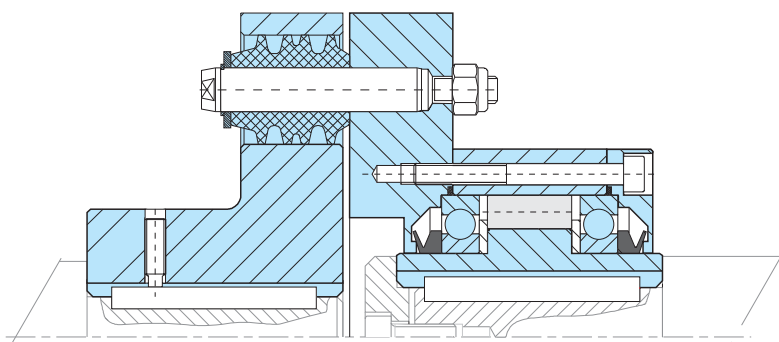

AL..KMSD2



TYPE



Type AL..KMSD2 is a roller type freewheel, self-contained, sealed and bearing supported, using two 160.. series bearings. Unit is delivered oil lubricated. This combination is used as overrunning clutch as shown overleaf.

In this design, a standard AL freewheel is connected to a KMS flexible coupling for in-line mounting. The KMS type is a rugged coupling, economical and suitable for

many applications. D2 cover is used to close the unit. It is equipped with two screws for oil filling, drain and level. We recommend the unit is supplied assembled.

Please specify inner race direction of rotation seen from the D2 flange. Refer to manufacturer's catalogue to check coupling selection.

Coupling half: keyway tolerance P9

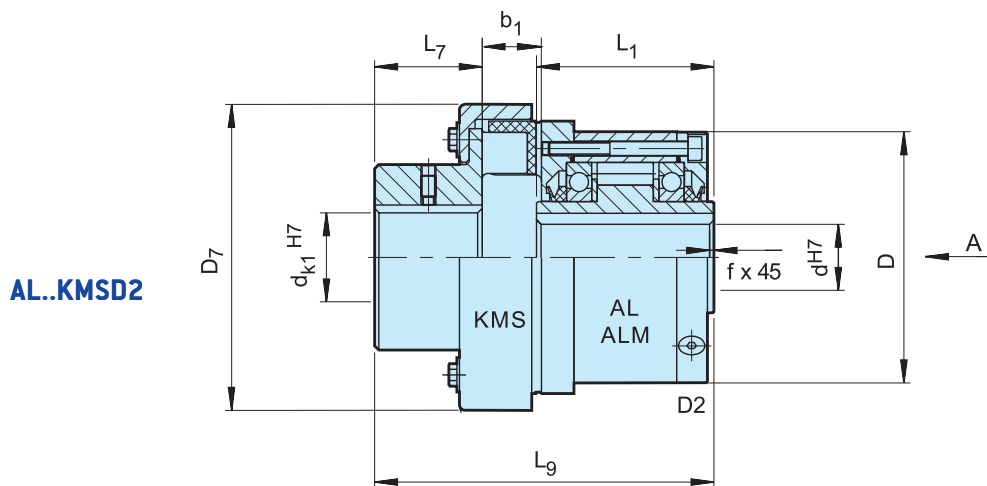

| Type | Size | KMS | T_{KN} [Nm] | Overrunning speeds | | | | | | | | Weight [kg] | |
|-------------|------------|------------|------------------|---|---|-----------------------|-----------|---------------|---------------|---------------|---------------|----------------|---------------|
| | | | | $n_{imax}^{1)}$ [min ⁻¹] | $n_{amax}^{2)}$ [min ⁻¹] | d_{k1}^{H7} [mm] | D [mm] | L_1 [mm] | D_7 [mm] | L_7 [mm] | L_9 [mm] | | b_1 [mm] |
| AL..KMSD2 | 12 | 4 | 50 | 2500 | 6000 | 7... 35 | 62 | 42 | 78 | 40 | 100 | 18 | 2,10 |
| | 15 | 6,3 | 79 | 1900 | 6000 | 12... 40 | 68 | 52 | 90 | 45 | 116 | 20 | 2,70 |
| | 20 | 10 | 125 | 1600 | 5600 | 10... 45 | 75 | 57 | 107 | 48 | 123,5 | 17 | 3,80 |
| | 25 | 10 | 125 | 1400 | 4500 | 10... 45 | 90 | 60 | 107 | 48 | 126,5 | 17 | 4,4 |
| | 30 | 16 | 200 | 1300 | 4100 | 10... 50 | 100 | 68 | 120 | 52 | 140 | 19 | 5,9 |
| | 35 | 25 | 313 | 1100 | 3800 | 15... 55 | 110 | 74 | 134 | 57 | 155 | 22 | 8,1 |
| | 40 | 40 | 500 | 950 | 3400 | 20... 60 | 125 | 86 | 155 | 61 | 173 | 26 | 11,4 |
| | 45 | 63 | 788 | 900 | 3200 | 20... 70 | 130 | 86 | 174 | 67 | 186 | 30 | 13,3 |
| | 50 | 100 | 1250 | 850 | 2800 | 25... 75 | 150 | 92 | 195 | 75 | 208,5 | 35 | 19,1 |
| | 55 | 100 | 1250 | 720 | 2650 | 25... 75 | 160 | 104 | 195 | 75 | 216,5 | 35 | 20,4 |
| | 60 | 160 | 2000 | 680 | 2450 | 30... 80 | 170 | 114 | 221 | 82 | 243 | 41 | 27,1 |
| | 70 | 250 | 3125 | 580 | 2150 | 35... 90 | 190 | 134 | 250 | 89 | 277,5 | 47 | 40,4 |
| | 80 | 400 | 5000 | 480 | 1900 | 45... 100 | 210 | 144 | 282 | 97 | 305 | 56 | 57 |
| | 90 | 630 | 7875 | 380 | 1700 | 60... 120 | 230 | 158 | 332 | 116 | 346,5 | 64 | 87 |
| | 100 | 1000 | 12500 | 350 | 1450 | 75... 140 | 270 | 182 | 382 | 140 | 386 | 75 | 131 |
| | 120 | 1600 | 20000 | 250 | 1250 | 90... 160 | 310 | 202 | 432 | 160 | 430 | 85 | 196 |
| | 150 | On Request | | | | | | | | | | | |
| 200 | On Request | | | | | | | | | | | | |
| 250 | On Request | | | | | | | | | | | | |
| ALM.. KMSD2 | 25 | 16 | 200 | 1100 | 2800 | 12... 50 | 90 | 60 | 120 | 52 | 132,5 | 19 | 4,4 |
| | 30 | 25 | 313 | 1000 | 2500 | 15... 55 | 100 | 68 | 134 | 57 | 150 | 22 | 5,9 |
| | 35 | 40 | 500 | 900 | 2400 | 18... 60 | 110 | 74 | 155 | 61 | 163 | 26 | 8,1 |

NOTES

1) Inner race overruns

2) Outer race overruns

Keyway to DIN 6885.1

When ordering, please specify bore $\varnothing d_k$ and direction of rotation seen from arrow „A“: „R“ Inner race overruns in clockwise direction, „L“ Inner race overruns in counter-clockwise direction

» Refer to mounting and maintenance instructions page 16 to 19

MOUNTING EXAMPLE

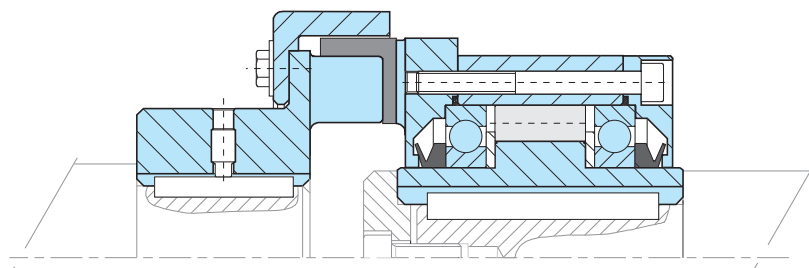

GFR GFRN

TYPE



GFR

GFRN

Types GFR,GFRN are roller type freewheels. These units are part of the Stieber modular system. They are bearing supported, using two 160.. series bearings, and require oil lubrication. These units may be used in designs providing oil lubrication and sealing as on the example overleaf. The bearings must not be axially stressed.

Typically, types GFR,GFRN are used with the F series covers that are designed to transmit torque, and provide oil lubrication and sealing. Usually these covers are used

in pairs according to combinations shown on the following pages. The outer race of the GFR model is plain to receive and center any component bored to H7 tolerance.

Torque is transmitted by bolts through the cover plate in this case. Types GFR, GFRN are identical except that type GFRN has a keyway on the outside diameter to transmit the torque. Two paper seals are delivered with each unit to be placed between the outer race and cover plates.

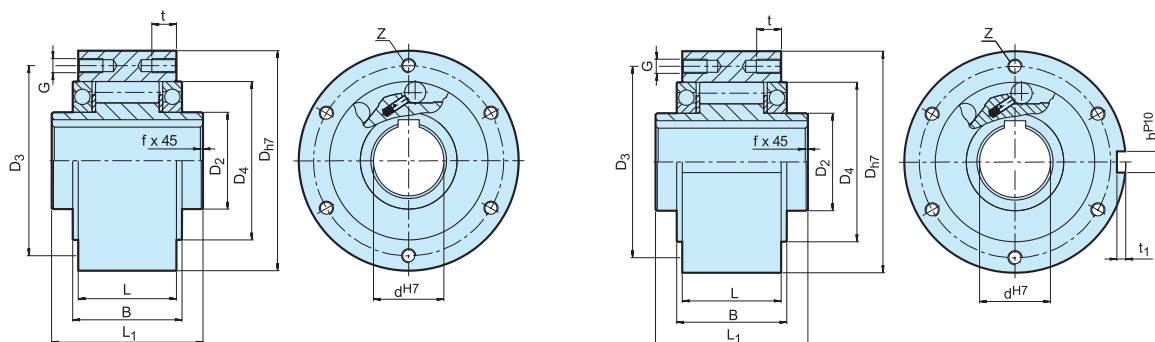

GFR

GFRN

| Type | Size | Overrunning speeds | | | | | | | Number | | | | | | | Weight | | |
|-------------|-------|-----------------------|-----------------------|---|---|------------------|---------------|---------------|---------------|----|-----------|-----|---------------|-----------|-----------|--------|---------------|-------------------|
| | | $d_{H7}^{1)}$ [mm] | $T_{KN}^{1)}$ [Nm] | $n_{imax}^{2)}$ [min ⁻¹] | $n_{amax}^{3)}$ [min ⁻¹] | D_{H7} [mm] | D_2 [mm] | D_4 [mm] | D_3 [mm] | G | t [mm] | z | L_1 [mm] | L [mm] | B [mm] | | t_1 [mm] | b^{P10} [mm] |
| GFR GFRN | 12* | 55 | 4000 | 7200 | 62 | 20 | 42 | 51 | ø5,5 | — | 3 | 42 | 20 | 27 | 2,5 | 4 | 0,5 | 0,5 |
| | 15 | 125 | 3600 | 6500 | 68 | 25 | 47 | 56 | M5 | 8 | 3 | 52 | 28 | 32 | 3 | 5 | 0,8 | 0,8 |
| | 20 | 181 | 2700 | 5600 | 75 | 30 | 55 | 64 | M5 | 8 | 4 | 57 | 34 | 39 | 3,5 | 6 | 0,8 | 1,0 |
| | 25 | 288 | 2100 | 4500 | 90 | 40 | 68 | 78 | M6 | 10 | 4 | 60 | 35 | 40 | 4 | 8 | 1,0 | 1,5 |
| | 30 | 500 | 1700 | 4100 | 100 | 45 | 75 | 87 | M6 | 10 | 6 | 68 | 43 | 48 | 4 | 8 | 1,0 | 2,2 |
| | 35 | 725 | 1550 | 3800 | 110 | 50 | 80 | 96 | M6 | 12 | 6 | 74 | 45 | 51 | 5 | 10 | 1,0 | 3,0 |
| | 40 | 1025 | 1150 | 3400 | 125 | 55 | 90 | 108 | M8 | 14 | 6 | 86 | 53 | 59 | 5 | 12 | 1,5 | 4,6 |
| | 45 | 1125 | 1000 | 3200 | 130 | 60 | 95 | 112 | M8 | 14 | 8 | 86 | 53 | 59 | 5,5 | 14 | 1,5 | 4,7 |
| | 50 | 2125 | 800 | 2800 | 150 | 70 | 110 | 132 | M8 | 14 | 8 | 94 | 64 | 72 | 5,5 | 14 | 1,5 | 7,2 |
| | 55 | 2625 | 750 | 2650 | 160 | 75 | 115 | 138 | M10 | 16 | 8 | 104 | 66 | 72 | 6 | 16 | 2,0 | 8,6 |
| | 60 | 3500 | 650 | 2450 | 170 | 80 | 125 | 150 | M10 | 16 | 10 | 114 | 78 | 89 | 7 | 18 | 2,0 | 10,5 |
| | 70 | 5750 | 550 | 2150 | 190 | 90 | 140 | 165 | M10 | 16 | 10 | 134 | 95 | 108 | 7,5 | 20 | 2,5 | 13,5 |
| | 80 | 8500 | 500 | 1900 | 210 | 105 | 160 | 185 | M10 | 16 | 10 | 144 | 100 | 108 | 9 | 22 | 2,5 | 18,2 |
| | 90 | 14500 | 450 | 1700 | 230 | 120 | 180 | 206 | M12 | 20 | 10 | 158 | 115 | 125 | 9 | 25 | 3,0 | 28,5 |
| | 100 | 20000 | 350 | 1450 | 270 | 140 | 210 | 240 | M16 | 24 | 10 | 182 | 120 | 131 | 10 | 28 | 3,0 | 42,5 |
| 130 | 31250 | 250 | 1250 | 310 | 160 | 240 | 278 | M16 | 24 | 12 | 212 | 152 | 168 | 11 | 32 | 3,0 | 65,0 | |
| 150 | 70000 | 200 | 980 | 400 | 200 | 310 | 360 | M20 | 32 | 12 | 246 | 180 | 194 | 12 | 36 | 4,0 | 138,0 | |

NOTES

- 1) $T_{max} = 2 \times T_{KN}$
» Refer to Selection page 10 to 13
- 2) Inner race overruns. Values without radial lip seals
- 3) Outer race overruns. Values without radial lip seals
Keyway to DIN 6885.1
- *) GFR12 has through holes in outer race
» Refer to mounting and maintenance instructions
page 16 to 19

MOUNTING EXAMPLE

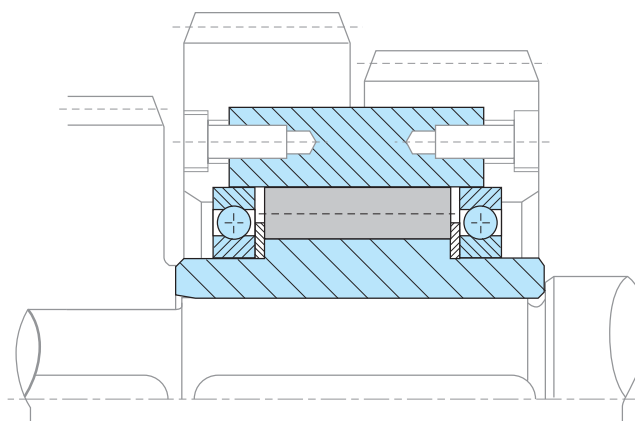

GFR..F1F2 GFR..F2F7 GFRN..F5F6



TYPE



GFRN..F5F6

GFR..F2F7

GFR..F1F2

Types GFR..F1F2/F2F7 and GFRN..F5F6 are roller type freewheels, self-contained, sealed and bearing supported, using two 160.. series bearings.

They use the GFR, GFRN base modules described on previous pages. Units must be oil lubricated before use if they are delivered disassembled. Primarily used as overrunning or indexing clutches, the cover combination is chosen according to the type of drive, as shown overleaf.

F2 and F6 covers are used to close the unit. They are equipped with 3 screws for oil filling, drain and level.

The shaft seal is a standard lip seal. Covers may be easily assembled by a qualified user, allowing direction of rotation to be selected on site. Alternatively, units can be delivered assembled and lubricated (except GFRN.. F5F6).

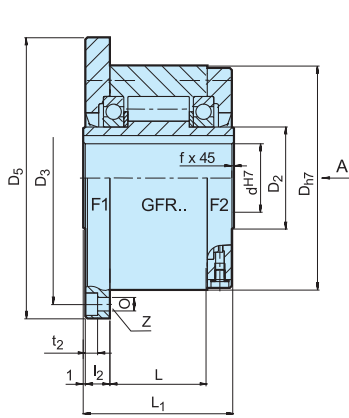

GFR...F1F2

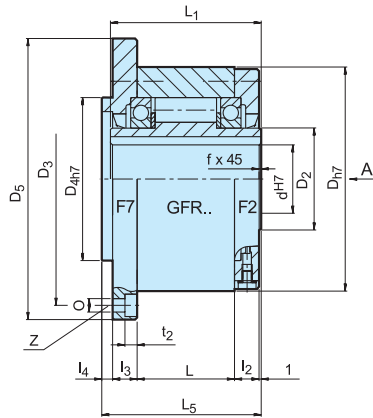

GFR...F2F7

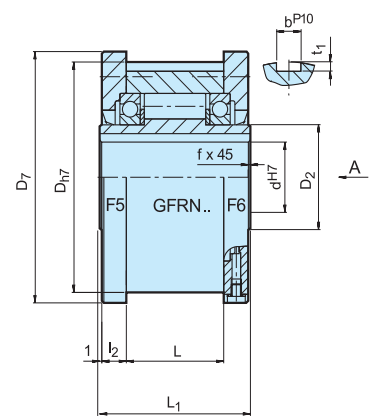

GFRN...F5F6

| Type | Size | Overrunning speeds | | | | Number | | | | | | | Keyway outer race | | | | | | | Weight | | |
|---|-------|-----------------------|-----------------------|---|---|----------|-------|-------|-------|-----------|------|-------|-------------------|-------|-------|------|-------|-------|-------|--------|-------|-----------|
| | | $d_{h7}^{1)}$ (mm) | $T_{KN}^{1)}$ (Nm) | $n_{imax}^{2)}$ (min ⁻¹) | $n_{amax}^{3)}$ (min ⁻¹) | D_{h7} | D_5 | D_7 | D_3 | D_{4h7} | 0 | t_2 | z | L_1 | L_5 | L | l_2 | l_3 | l_4 | | t_1 | b^{P10} |
| GFR...F1F2, GFR...F2F7, GFRN...F5F6 | 12 | 55 | 3100 | 4700 | 62 | 85 | 70 | 72 | 42 | 5,5 | 5,7 | 3 | 42 | 44 | 20 | 10 | 10 | 3 | 2,5 | 4 | 0,5 | 1,2 |
| | 15 | 125 | 2800 | 4400 | 68 | 92 | 76 | 78 | 47 | 5,5 | 5,7 | 3 | 52 | 54 | 28 | 11 | 11 | 3 | 3 | 5 | 0,8 | 1,6 |
| | 20 | 181 | 2400 | 4100 | 75 | 98 | 84 | 85 | 55 | 5,5 | 5,7 | 4 | 57 | 59 | 34 | 10,5 | 10,5 | 3 | 3,5 | 6 | 0,8 | 1,9 |
| | 25 | 288 | 1600 | 3800 | 90 | 118 | 99 | 104 | 68 | 6,6 | 6,8 | 4 | 60 | 62 | 35 | 11,5 | 11,5 | 3 | 4 | 8 | 1,0 | 2,9 |
| | 30 | 500 | 1300 | 2800 | 100 | 128 | 109 | 114 | 75 | 6,6 | 6,8 | 6 | 68 | 70 | 43 | 11,5 | 11,5 | 3 | 4 | 8 | 1,0 | 3,9 |
| | 35 | 725 | 1200 | 2600 | 110 | 140 | 119 | 124 | 80 | 6,6 | 6,8 | 6 | 74 | 76 | 45 | 13,5 | 13 | 3,5 | 5 | 10 | 1,0 | 4,9 |
| | 40 | 1025 | 850 | 2300 | 125 | 160 | 135 | 142 | 90 | 9 | 9 | 6 | 86 | 88 | 53 | 15,5 | 15 | 3,5 | 5 | 12 | 1,5 | 7,5 |
| | 45 | 1125 | 740 | 2200 | 130 | 165 | 140 | 146 | 95 | 9 | 9 | 8 | 86 | 88 | 53 | 15,5 | 15 | 3,5 | 5,5 | 14 | 1,5 | 7,8 |
| | 50 | 2125 | 580 | 1950 | 150 | 185 | 160 | 166 | 110 | 9 | 9 | 8 | 94 | 96 | 64 | 14 | 13 | 4 | 5,5 | 14 | 1,5 | 10,8 |
| | 55 | 2625 | 550 | 1800 | 160 | 204 | 170 | 182 | 115 | 11 | 11 | 8 | 104 | 106 | 66 | 18 | 17 | 4 | 6 | 16 | 2,0 | 14,0 |
| | 60 | 3500 | 530 | 1700 | 170 | 214 | 182 | 192 | 125 | 11 | 11 | 10 | 114 | 116 | 78 | 17 | 16 | 4 | 7 | 18 | 2,0 | 16,8 |
| | 70 | 5750 | 500 | 1600 | 190 | 234 | 202 | 212 | 140 | 11 | 11 | 10 | 134 | 136 | 95 | 18,5 | 17,5 | 4 | 7,5 | 20 | 2,5 | 20,8 |
| | 80 | 8500 | 480 | 1500 | 210 | 254 | 222 | 232 | 160 | 11 | 11 | 10 | 144 | 146 | 100 | 21 | 20 | 4 | 9 | 22 | 2,5 | 27,0 |
| | 90 | 14500 | 450 | 1300 | 230 | 278 | 242 | 254 | 180 | 14 | 13 | 10 | 158 | 160 | 115 | 20,5 | 19 | 4,5 | 9 | 25 | 3,0 | 40,0 |
| | 100 | 20000 | 350 | 1100 | 270 | 335 | 282 | 305 | 210 | 18 | 17,5 | 10 | 182 | 184 | 120 | 30 | 28 | 5 | 10 | 28 | 3,0 | 67,0 |
| 130 | 31250 | 250 | 900 | 310 | 380 | 322 | 345 | 240 | 18 | 17,5 | 12 | 212 | 214 | 152 | 29 | 27 | 5 | 11 | 32 | 3,0 | 94,0 | |
| 150 | 70000 | 200 | 700 | 400 | 485 | 412 | 445 | 310 | 22 | 21,5 | 12 | 246 | 248 | 180 | 32 | 30 | 5 | 12 | 36 | 4,0 | 187,0 | |

NOTES

1) $T_{max} = 2 \times T_{KN}$
» Refer to Selection page 10 to 13

2) Inner race overruns

3) Outer race overruns
Keyway to DIN 6885.1

When ordered assembled, please specify direction of rotation seen from arrow „A“: „R“ Inner race overruns in clockwise direction „L“ Inner race overruns in counter-clockwise direction

» Refer to mounting and maintenance instructions page 16 to 19

MOUNTING EXAMPLES

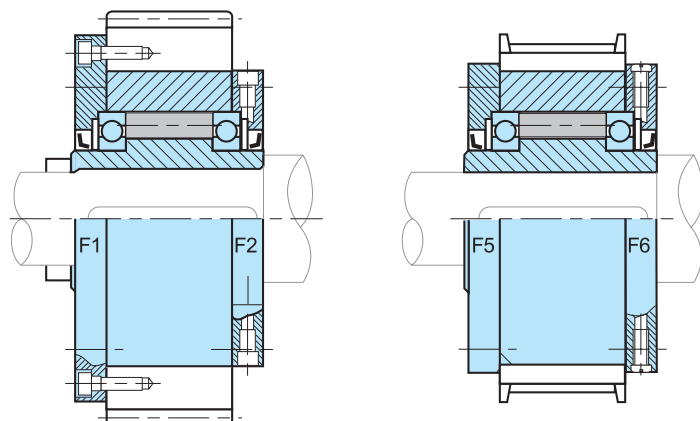

GFR..F2F3

GFR..F3F4



TYPE



GFR..F2F3

GFR..F3F4

Types GFR..F2F3/F3F4 are roller type freewheels, self-contained, sealed and bearing supported, using two 160.. series bearings.

They use the GFR base module. Units must be oil lubricated before use if they are delivered disassembled and in any case for the F3F4 combination. These cover combinations are primarily used as backstops, as shown overleaf. The F3 cover acts as a torque arm and has an integrated stop bolt. The stop bolt should go into a slot in a fixed part of the machine. The stop bolt must have a radial

clearance of 1–3 % of the bolt's diameter. The torque arm and bearings must not be prestressed in any way. F2 and F4 covers are used to close the unit. They are equipped with 3 screws for oil filling, drain and level.

If using cover type F4, shaft end plate and its screw must be sealed to avoid oil leakage through the keyway. Covers are easily fitted, allowing on site selection of rotation direction. If requested units can be delivered assembled and lubricated for the F2F3 combination.

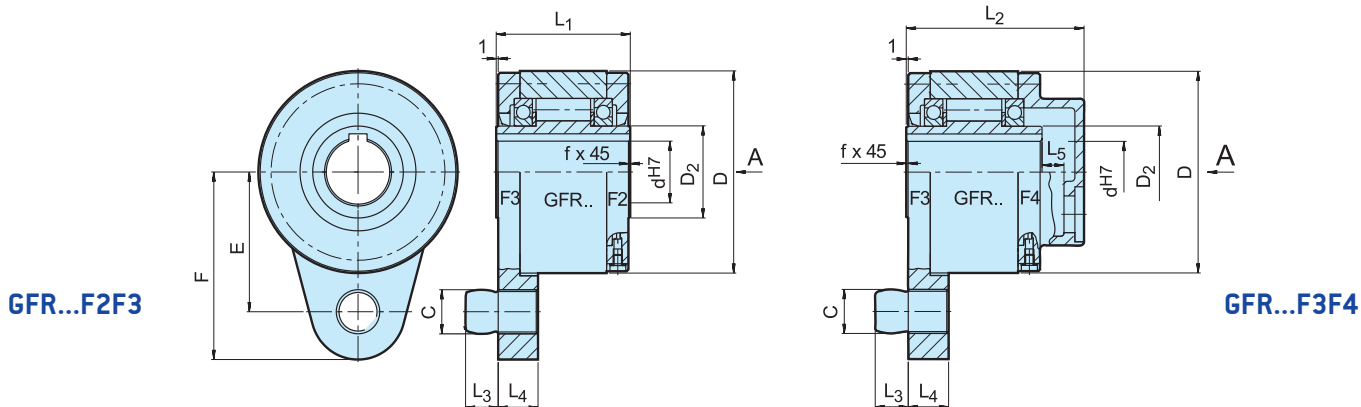

| Type | Size | Overrunning speed | | | | | | | | | | | | | Weight |
|--------------------------|-------|-------------------|-----------------------|---|-----------|------------------------|-----------|------------------------|------------------------|------------------------|------------------------|-----------|-----------|------------------------|--------|
| | | d^{H7} [mm] | $T_{KN}^{1)}$ [Nm] | $n_{imax}^{2)}$ [min ⁻¹] | D [mm] | D ₂ [mm] | C [mm] | L ₁ [mm] | L ₂ [mm] | L ₃ [mm] | L ₄ [mm] | F [mm] | E [mm] | L ₅ [mm] | |
| GFR..F2-F3 GFR..F3-F4 | 12 | 55 | 3100 | 62 | 20 | 10 | 42 | 64 | 10 | 13 | 59 | 44 | 6 | 0,5 | 1,4 |
| | 15 | 125 | 2800 | 68 | 25 | 10 | 52 | 78 | 10 | 13 | 62 | 47 | 10 | 0,8 | 1,8 |
| | 20 | 181 | 2400 | 75 | 30 | 12 | 57 | 82 | 11 | 15 | 72 | 54 | 10 | 0,8 | 2,3 |
| | 25 | 288 | 1600 | 90 | 40 | 16 | 60 | 85 | 14 | 18 | 84 | 62 | 10 | 1,0 | 3,4 |
| | 30 | 500 | 1300 | 100 | 45 | 16 | 68 | 95 | 14 | 18 | 92 | 68 | 10 | 1,0 | 4,5 |
| | 35 | 725 | 1200 | 110 | 50 | 20 | 74 | 102 | 18 | 25 | 102 | 76 | 12 | 1,0 | 5,6 |
| | 40 | 1025 | 850 | 125 | 55 | 20 | 86 | 115 | 18 | 25 | 112 | 85 | 12 | 1,5 | 8,5 |
| | 45 | 1125 | 740 | 130 | 60 | 25 | 86 | 115 | 22 | 25 | 120 | 90 | 12 | 1,5 | 8,9 |
| | 50 | 2125 | 580 | 150 | 70 | 25 | 94 | 123 | 22 | 25 | 135 | 102 | 12 | 1,5 | 12,8 |
| | 55 | 2625 | 550 | 160 | 75 | 32 | 104 | 138 | 25 | 30 | 142 | 108 | 15 | 2,0 | 16,2 |
| | 60 | 3500 | 530 | 170 | 80 | 32 | 114 | 147 | 25 | 30 | 145 | 112 | 15 | 2,0 | 19,3 |
| | 70 | 5750 | 500 | 190 | 90 | 38 | 134 | 168 | 30 | 35 | 175 | 135 | 16 | 2,5 | 23,5 |
| | 80 | 8500 | 480 | 210 | 105 | 38 | 144 | 178 | 30 | 35 | 185 | 145 | 16 | 2,5 | 32 |
| | 90 | 14500 | 450 | 230 | 120 | 50 | 158 | 192 | 40 | 45 | 205 | 155 | 16 | 3,0 | 47,2 |
| | 100 | 20000 | 350 | 270 | 140 | 50 | 182 | 217 | 40 | 45 | 230 | 180 | 16 | 3,0 | 76 |
| 130 | 31250 | 250 | 310 | 160 | 68 | 212 | 250 | 55 | 60 | 268 | 205 | 18 | 3,0 | 110 | |
| 150 | 70000 | 200 | 400 | 200 | 68 | 246 | 286 | 55 | 60 | 325 | 255 | 20 | 4,0 | 214 | |

NOTES

1) $T_{max} = 2 \times T_{KN}$
» Refer to Selection page 10 to 13

2) Inner race overruns
Keyway to DIN 6885.1

When ordered assembled, please specify direction of rotation seen from arrow „A“: „R“ Inner race overruns in clockwise direction, „L“ Inner race overruns in counter-clockwise direction

» Refer to mounting and maintenance instructions page 16 to 19

MOUNTING EXAMPLE

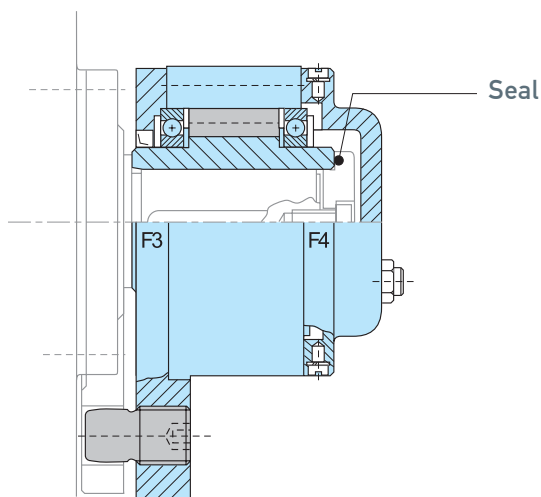

SMZ

TYPE



Type SMZ is a sealed, sprag type freewheel, bearing supported using two 60..ZZ series grease lubricated bearings.

Units are delivered grease lubricated ready for installation. SMZ units are intended as multipurpose, to be used in various applications. A typical mounting

arrangement is shown on the following page. The inner race is keyed to the shaft. The inside diameter of the outer race (dimension D4) should be used as the mounting register for the connected parts (sprocket, pulley, gear, torque arm...). The mounting spigot should be to g6 tolerance.

SMZ

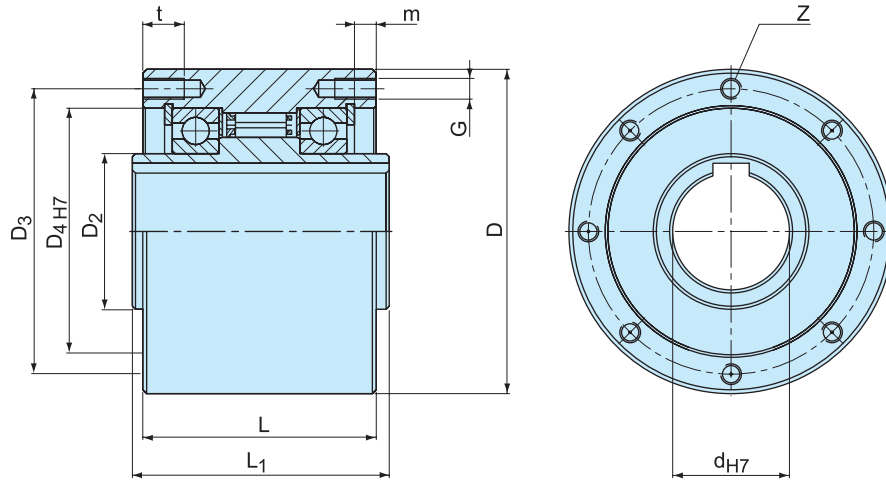

| Type | Size | Overrunning speeds | | | | | | | | | | | | | | Weight |
|------|------|-----------------------|--|---|-----|----------------|----------------|------------------------------|-----|----------------|----|---|----|-----|------|--------|
| | | $T_{KN}^{1)}$ [Nm] | $n_{max}^{2)}$ [min ⁻¹] | $n_{amax}^{3)}$ [min ⁻¹] | D | D ₂ | D ₃ | D ₄ ^{H7} | L | L ₁ | G | z | t | m | | |
| SMZ | 20 | 300 | 1600 | 700 | 80 | 30 | 68 | 55 | 65 | 67 | M6 | 6 | 12 | 7.6 | 2 | |
| | 30 | 1035 | 1500 | 500 | 100 | 45 | 88 | 75 | 80 | 82 | M8 | 6 | 16 | 8.9 | 3.7 | |
| | 35 | 1100 | 1400 | 300 | 110 | 50 | 95 | 80 | 85 | 87 | M8 | 6 | 16 | 8.7 | 4.8 | |
| | 45 | 1750 | 1300 | 300 | 125 | 60 | 110 | 95 | 90 | 92 | M8 | 8 | 16 | 8.4 | 6.2 | |
| | 60 | 3400 | 1100 | 250 | 155 | 80 | 140 | 125 | 100 | 102 | M8 | 8 | 16 | 9.1 | 10.2 | |
| | 70 | 4300 | 1000 | 250 | 175 | 95 | 162 | 145 | 103 | 105 | M8 | 8 | 16 | 8.6 | 13.2 | |

NOTES

- 1) $T_{max} = 2 \times T_{KN}$
» Refer to Selection page 10 to 13
- 2) Inner race overruns
- 3) Outer race overruns
Keyway to DIN 6885.1
- » Refer to mounting and maintenance instructions
page 16 to 19

MOUNTING EXAMPLE

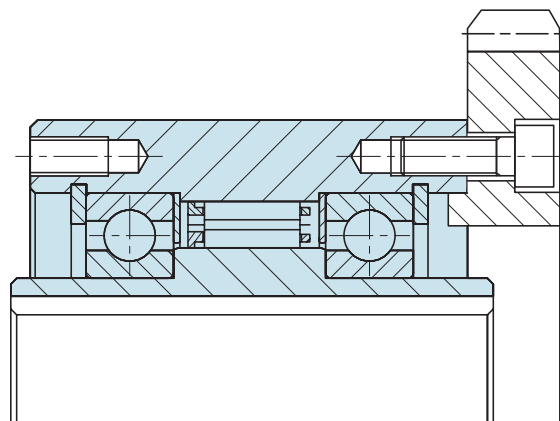

FSO 300-700 FSO-GR 300-700 HPI 300-700



TYPE



FSO..GR

Types FSO, FSO-GR, and HPI 300 to 700 are sprag type freewheels self-contained, sealed and bearing supported, using two ball bearings.

Units are delivered oil or grease lubricated according to the type. It is a Formsprag USA design with a »full sprag complement« that gives a very high torque for a

given diameter. Any overload is resisted by a sprag to sprag abutment, avoiding a sprag tilt over. Type FSO is oil lubricated and uses standard shaft lip seals. Type FSO-GR is grease lubricated and can be equipped with contact free labyrinth seals. Type HPI is specially designed for high speed indexing applications.

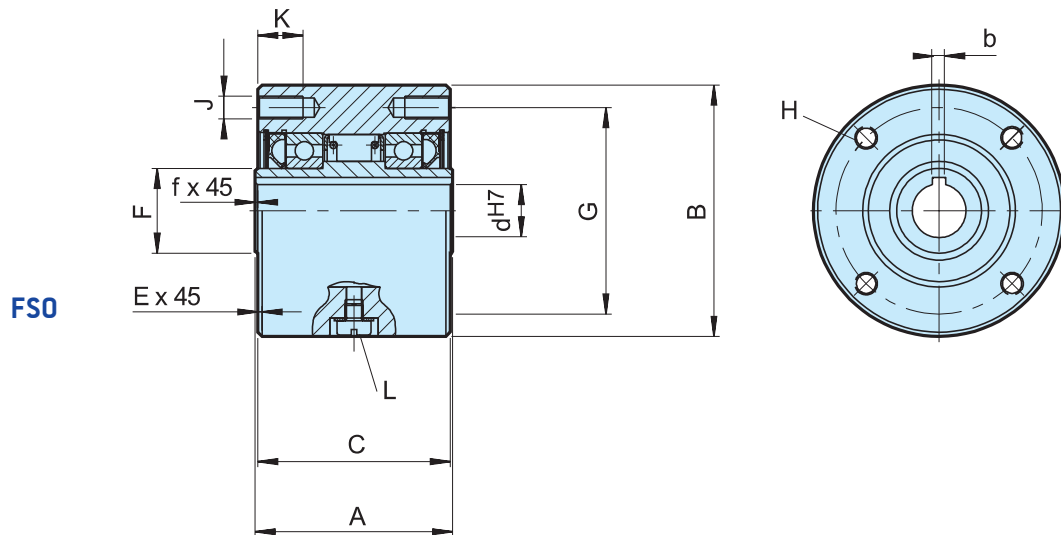

| Type | Size | Overrunning speeds | | | | | | | | | | | | | | Lubricant | | | Weight | Drag torque | | | |
|----------------------|------|---------------------------------------|--|--|-----------------|----------|----------|---------|---------|------|---------------------|--------|-------|------|----|-----------|-----|---------|--------|-------------|-----|----------------|----|
| | | FSO | FSO-GR | d ^{H7} -bxh | d ^{h1} | A | B | C | E | F | G | H | J | K | L | f | FSO | FSO..GR | | | HPI | T _R | |
| | | T _{KN} ¹⁾ [Nm] | n _{max} ²⁾ [min ⁻¹] | n _{max} ³⁾ [min ⁻¹] | | min-max | -0,05 | | | | | | | | | | | | | | | | |
| FSO FSO-GR HPI | 300 | 379 | 3000/900 | 3600/900 | 15-5x5 | 12... 19 | 63,50 | 76,20 | 60,45 | 1,6 | 28,58 | 66,67 | 4 | M8 | 13 | M6 | 0,8 | 7 | 10 | 14 | 1,6 | 18 | |
| | 400 | 407 | 2800/850 | 3600/850 | 18-6x6 | 12... 22 | 69,85 | 88,90 | 68,07 | 1,6 | 30 | 73 | 4 | M8 | 13 | M6 | 0,8 | 10 | 20 | 20 | 2,7 | 27 | |
| | 500 | 1621 | 2500/800 | 3000/800 | 30-8x7 | 19... 33 | 88,90 | 107,95 | 85,73 | 1,6 | 45 | 92 | 4 | M8 | 16 | M6 | 1,5 | 22 | 35 | 35 | 4,8 | 31 | |
| | 600 | 3105 | 2200/750 | 2400/750 | 40-12x8 | | | | | | | | | | | | | | | | | | |
| | | | | | | 45-14x9 | 24... 57 | 95,25 | 136,525 | 92,2 | 1,6 | 63,5 | 120,6 | 6 | M8 | 16 | M6 | 1,6 | 52 | 84 | 84 | 8,6 | 62 |
| | | | | | | 50-14x6 | | | | | | | | | | | | | | | | | |
| | | | | | | 50-14x9 | | | | | | | | | | | | | | | | | |
| | 700 | 6900 | 1600/450 | 2000/450 | 60-18x11 | 48... 82 | 127,00 | 180,975 | 123,85 | 1,6 | 90 | 158,75 | 8* | M10* | 20 | M6 | 1,6 | 168 | 280 | 280 | 19 | 156 | |
| | | | | | 65-18x11 | | | | | | | | | | | | | | | | | | |
| | | | | | 70-20x12 | | | | | | 101,6 ⁵⁾ | | | | | | | | | | | | |

NOTES

- 1) $T_{max} = 2 \times T_{KN}$
» Refer to Selection page 10 to 13
 - 2) Inner race/outer race
 - 3) Inner race/outer race labyrinth seal
 - 4) Inch bore available on request
 - 5) Only for oversize bore
Size 600 > 50 mm
Size 700 > 75 mm
 - *) 6 holes equally spaced at 60° plus
2 extra-holes at 180°
- » Refer to mounting and maintenance instructions
page 16 to 19

EMOUNTING EXAMPLE

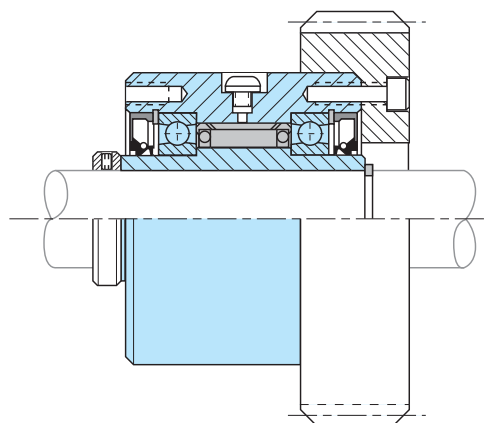

FS 750-1027 FSO 750-1027 HPI 750-1027



TYPE



FSO

Types FS, FSO, and HPI 750 to 1027 are sprag type freewheels self-contained, sealed and bearing supported, using two ball bearings.

Units are delivered oil or grease lubricated according to the type. It is a Formsprag USA design that uses tall sprags with multi-radius active surfaces. Designed specially for large size freewheels to compensate for any eccentricity due to bearing wear. Type FS is oil lubricated

and uses standard shaft lip seals. Type FSO is grease lubricated and equipped with special grease seals.

Type HPI is specially designed for high speed indexing applications. Each of the different models show a range of standard metric bore diameters. We can supply any bore size between the minimum and maximum specified in the table, including imperial sizes.

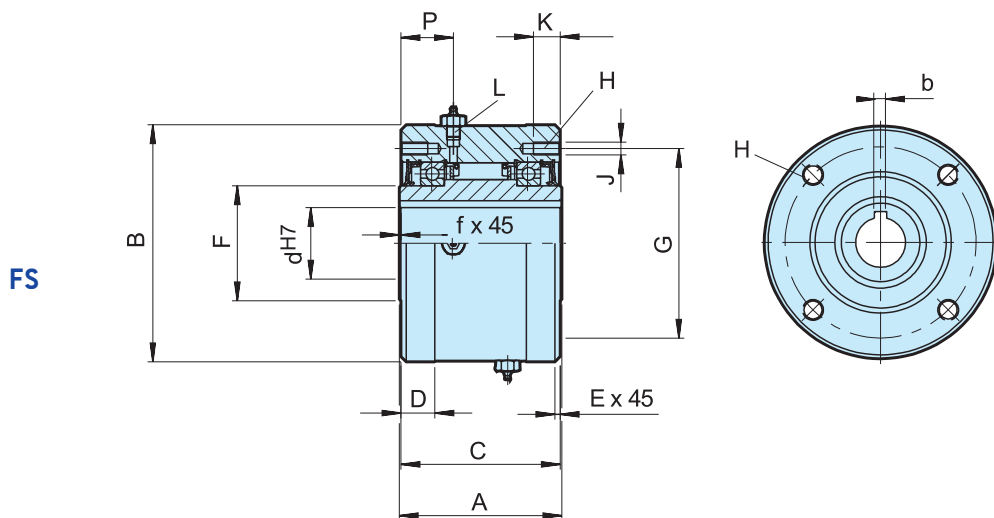

| Type | Size | Overrunning speeds | | | | | | | | | | | | | | | | | | Lubricant | | | Weight | Drag torque | | | | | |
|------------------|------|-----------------------|--|--|----------------------|-----------------------------|-----------|----------------------------------|-----------|-----------|-----------|-----------|-----------|-----------|-----------|-----------|-------------|-----------|-----------|-------------|-------------|------------|--------|----------------|-----|-----|-----|------|------|
| | | $T_{KN}^{1)}$ [Nm] | $n_{max}^{2)}$ [min ⁻¹] | $n_{max}^{3)}$ [min ⁻¹] | d^{H7-bxh} [mm] | $d^{4)}$ min-max [mm] | A [mm] | B ⁵⁾ -0.05 [mm] | C [mm] | D [mm] | E [mm] | F [mm] | G [mm] | H [mm] | J [mm] | K [mm] | L [inch] | P [mm] | f [mm] | FSO [ml] | HPI [ml] | FS [ml] | [kg] | T_R [Ncm] | | | | | |
| FSO FS HPI | 750 | 9660 | 1800/650 | 1000/450 | 65-18x11 | | | | | | | | | | | | | | | | | | | | | | | | |
| | | | | | 70-20x12 | | | | | | | | | | | | | | | | | | | | | | | | |
| | | | | | 75-20x12 | 57-87 | 152.4 | 222.25 | 149.2 | 31.7 | 1.6 | 107.74 | 177.8 | 8* | M12* | 25 | 1/2-20 | 49.2 | 1.6 | 222 | 384 | 207 | 38 | 5.08 | | | | | |
| | | | | | 80-22x14 | | | | | | | | | | | | | | | | | | | | | | | | |
| | | | | | 85-22x14 | | | | | | | | | | | | | | | | | | | | | | | | |
| | | | | | 80-22x14 | | | | | | | | | | | | | | | | | | | | | | | | |
| | | | | | 800 | 17940 | 1500/525 | 850/525 | 90-25x14 | 66-112 | 152.4 | 254.00 | 149.2 | 31.7 | 1.6 | 139.70 | 227.0 | 8 | M12 | 25 | 1/2-20 | 49.2 | 1.6 | 222 | 444 | 251 | 46 | 7.12 | |
| | | | | | | | | | 100-28x16 | | | | | | | | | | | | | | | | | | | | |
| | | | | | | | | | 110-28x16 | | | | | | | | | | | | | | | | | | | | |
| | | | | | | | | | 100-28x16 | | | | | | | | | | | | | | | | | | | | |
| | | | | | | 900 | 24408 | 1350/500 | 700/500 | 110-28x16 | 92-138 | 161.9 | 304.80 | 158.7 | 34.9 | 1.6 | 161.92 | 247.65 | 10 | M16 | 32 | 1/2-20 | 54 | 1.6 | 532 | 473 | 340 | 71 | 8.47 |
| | | | | | | | | | | 120-32x18 | | | | | | | | | | | | | | | | | | | |
| | | | | | | | | | | 130-32x18 | | | | | | | | | | | | | | | | | | | |
| | | | | | | | | | | 130-32x18 | | | | | | | | | | | | | | | | | | | |
| | 1027 | 36612 | 1100/375 | 500/375 | 150-36x20 | 125-177 | 168.3 | 381.00 | 165.1 | 34.9 | 3.2 | 228.60 | 298.45 | 12 | M16 | 32 | 1/2-20 | 54 | 3.2 | 651 | 946 | 473 | 113 | 13.56 | | | | | |
| | | | | | 175-45x25 | | | | | | | | | | | | | | | | | | | | | | | | |

NOTES

- $T_{max} = 2 \times T_{KN}$
» Refer to Selection page 10 to 13
- Inner race/outer race
- Inner race/outer race
- Inch bore available on request
- * 6 holes equally spaced at 60° plus 2 extra-holes at 180°
- 5) Tolerance for sizes 900 and 1027: -0,08

MOUNTING EXAMPLE

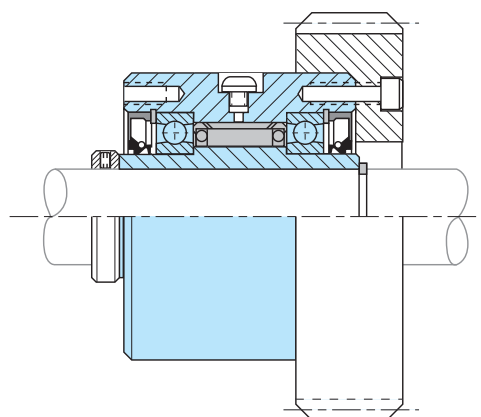

AL..G



TYPE

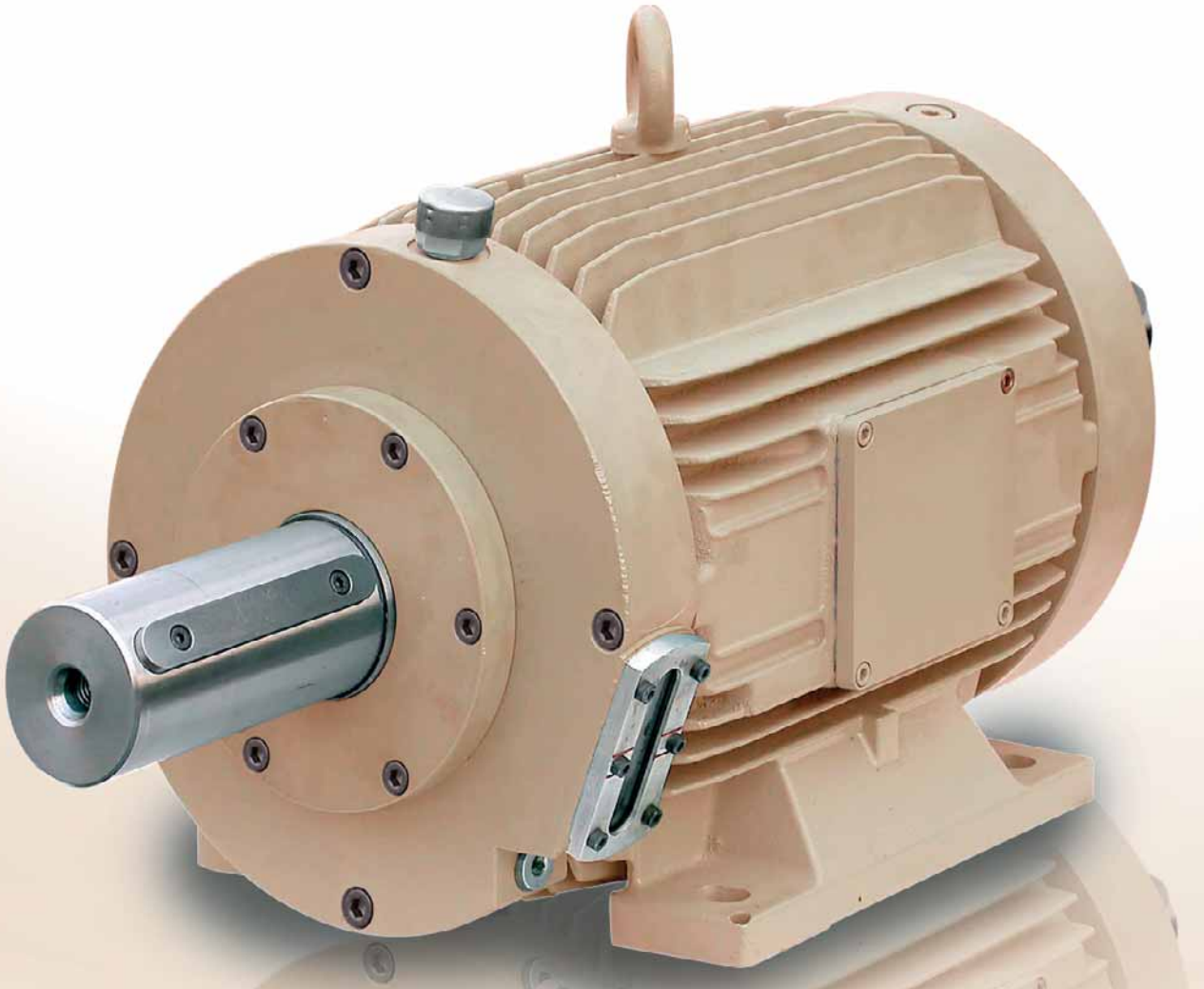

Type AL..G is a roller type freewheel bearing supported and self-contained in a cast iron housing. Standard lubrication is oil.

This type is designed for dual or standby drives on large equipment requiring high power at high speeds such as, industrial fans, pumps, and turbines. The housing provides a cooling surface, a large oil volume and maximum safety for equipment running continuously

without supervision. Units of this type must be connected with the driver and driven machine using flexible couplings.

Integrated forced lubrication allows hydrodynamic contact free operation during overrunning. The given overrunning speeds are valid for a maximum ambient temperature of 40°C. On request oil circulation from an external source, or additional air cooling can be provided.

AL..G

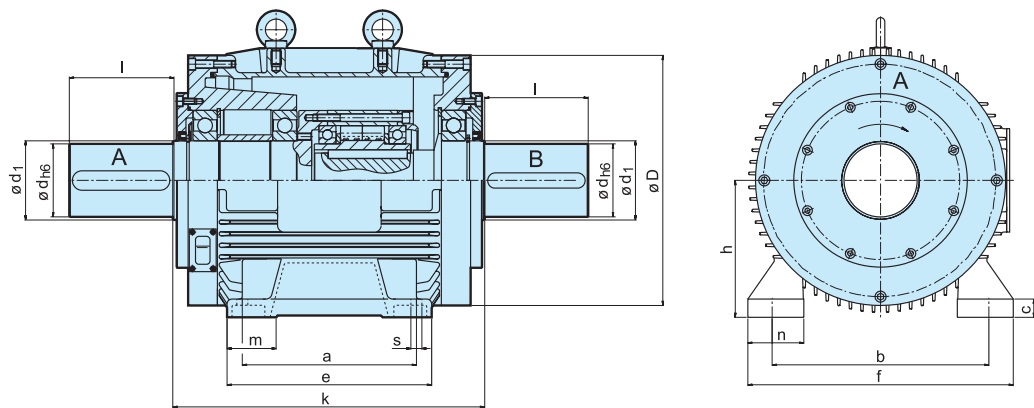

| Type | Size | Overrunning Speed shaft A | | | | | | | | | | | | | | | | Weight |
|-------|--------|---------------------------|-----------------------------------|------------------|-------------|-------------|-------------|---------------|-------------|-------------|-------------|-------------|-------------|-------------|-------------|-------------|-------------|--------|
| | | $T_{KN}^{1)}$ (Nm) | n_{max} (min ⁻¹) | d_{h6} (mm) | l (mm) | k (mm) | D (mm) | d_1 (mm) | h (mm) | m (mm) | n (mm) | f (mm) | e (mm) | a (mm) | b (mm) | s (mm) | c (mm) | (kg) |
| AL..G | 30-G1 | 288 | 5500 | 38 | 80 | 280 | 194 | 45 | 100 | 33,5 | 42 | 200 | 175 | 140 | 160 | 14 | 14 | 50 |
| | 40-G2 | 612 | 4000 | 42 | 110 | 330 | 258 | 55 | 132 | 40 | 55 | 260 | 218 | 178 | 216 | 14 | 16 | 85 |
| | 50-G3 | 1375 | 3400 | 65 | 140 | 430 | 310 | 80 | 160 | 58 | 71,5 | 318 | 260 | 210 | 254 | 18 | 22 | 115 |
| | 60-G3 | 2250 | 2900 | 75 | 140 | 430 | 310 | 80 | 160 | 58 | 71,5 | 318 | 260 | 210 | 254 | 18 | 22 | 125 |
| | 70-G3 | 3312 | 2600 | 75 | 140 | 430 | 310 | 80 | 160 | 58 | 71,5 | 318 | 260 | 210 | 254 | 18 | 22 | 138 |
| | 80-G4 | 5000 | 2400 | 90 | 170 | 510 | 434 | 95 | 225 | 80,5 | 92 | 436 | 346 | 286 | 356 | 22 | 30 | 284 |
| | 90-G4 | 9375 | 2000 | 120 | 170 | 510 | 434 | 130 | 225 | 80,5 | 92 | 436 | 346 | 286 | 356 | 22 | 30 | 300 |
| | 100-G4 | 11900 | 1700 | 100 | 210 | 510 | 434 | 130 | 225 | 80,5 | 92 | 436 | 346 | 286 | 356 | 22 | 30 | 330 |
| | 120-G5 | 20000 | 1500 | 120 | 210 | 800 | 610 | 130 | 315 | 100 | 131 | 620 | 550 | 457 | 508 | 30 | 46 | 980 |
| | 150-G5 | 45000 | 1200 | 160 | 250 | 800 | 610 | 190 | 315 | 100 | 131 | 620 | 550 | 457 | 508 | 30 | 46 | 1100 |

NOTES

- 1) $T_{max} = 2 \times T_{KN}$
 » Refer to Selection page 10 to 13
 Keyway to DIN 6885.1

rotation seen from shaft „A“: „R“ Shaft „A“ overruns in clockwise direction, „L“ Shaft „A“ overruns in counterclockwise direction

Note: The constant overrunning function must be performed by the driven shaft „A“

- » Refer to mounting and maintenance instructions page 16 to 19

MOUNTING EXAMPLE

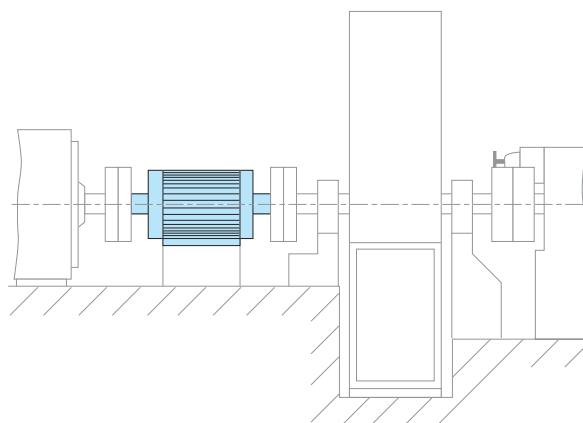

RSCI 20-130



TYPE



Type RSCI is a centrifugal lift off sprag type freewheel with the inner race rotating. Only the inner race is designed for freewheeling. It is a non self-supported type.

Bearings must be provided to ensure concentricity of the inner and outer races and support axial and radial loads, as shown overleaf. Concentricity and run-out limits must be observed. The RSCI type accepts all types of lubricant currently used in power transmission equipment.

It is possible to mount these freewheels directly in gear-boxes without separate lubrication. An oil mist is generally sufficient. Grease lubrication may be acceptable if the unit works mostly in overrunning condition, as on E-motors.

When used as a backstop, it must be checked that the overrunning speed will not go below the minimum speed given in the characteristics table. Please refer to page 78 (RSCI 180-300) for further information.

RSCI

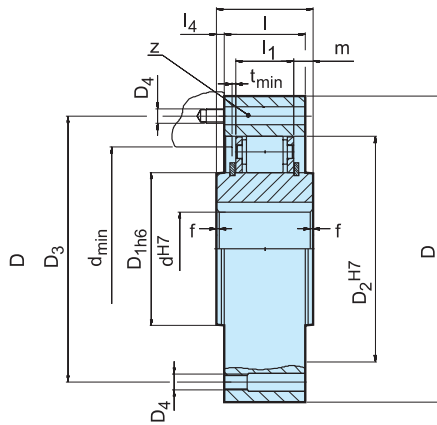

F8

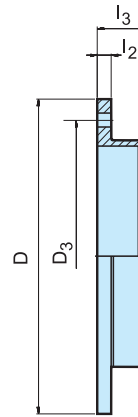

| Type | Size | Speeds | | | | Number | | | | | | | | | | Weight | | | | | | | |
|------|------------------|-----------------------|--|---|---|--------|-------------------|--------------------|---------------|-------|----|----|----|---------------|---------------|-----------------------------|-------------------|------|-------------------|---------------|---------------|--------------|------------|
| | d^{H7} (mm) | $T_{KN}^{1)}$ (Nm) | $n_{max}^{2)}$ (min ⁻¹) | $n_{imin}^{3)}$ (min ⁻¹) | $n_{imax}^{4)}$ (min ⁻¹) | D | D_{1h6} (mm) | D_2^{H7} (mm) | D_3 (mm) | D_4 | z | L | l | l_1 (mm) | l_4 (mm) | $f \times 45^\circ$ (mm) | d_{min} (mm) | m | t_{min} (mm) | l_2 (mm) | l_3 (mm) | RSCI (kg) | F8 (kg) |
| RSCI | 20 | 212 | 380 | 875 | 14500 | 90 | 36 | 66 | 78 | M6 | 6 | 35 | 35 | 25 | 0 | 0,8 | 52 | 5 | 1 | 8 | 16 | 1,5 | 0,3 |
| | 25 | 319 | 355 | 825 | 14300 | 95 | 40 | 70 | 82 | M6 | 6 | 35 | 35 | 25 | 0 | 1,0 | 56 | 5 | 1 | 8 | 16 | 1,6 | 0,4 |
| | 30 | 375 | 350 | 780 | 11400 | 100 | 45 | 75 | 87 | M6 | 6 | 35 | 35 | 25 | 0 | 1,5 | 62 | 5 | 1 | 8 | 16 | 1,8 | 0,4 |
| | 35 | 550 | 320 | 740 | 10500 | 110 | 50 | 80 | 96 | M6 | 8 | 35 | 35 | 25 | 0 | 1,5 | 66 | 5 | 1 | 8 | 16 | 2,1 | 0,5 |
| | 40 | 800 | 315 | 720 | 7600 | 125 | 60 | 90 | 108 | M8 | 8 | 35 | 35 | 25 | 0 | 1,5 | 76 | 5 | 1 | 10 | 21 | 2,7 | 0,7 |
| | 45 | 912 | 285 | 665 | 6600 | 130 | 65 | 95 | 112 | M8 | 8 | 35 | 35 | 25 | 0 | 1,5 | 82 | 5 | 1 | 10 | 21 | 2,9 | 0,9 |
| | 50 | 1400 | 265 | 610 | 6100 | 150 | 80 | 110 | 132 | M8 | 8 | 40 | 40 | 25 | 0 | 1,5 | 100 | 7,5 | 1 | 10 | 21 | 4,3 | 1 |
| | 60 | 2350 | 200 | 490 | 5300 | 175 | 85 | 125 | 155 | M10 | 8 | 60 | 50 | 36 | 5 | 2,0 | 110 | 12 | 2 | 12 | 35 | 6,5 | 1,8 |
| | 70 | 3050 | 210 | 480 | 4100 | 190 | 100 | 140 | 165 | M10 | 12 | 60 | 50 | 36 | 5 | 2,0 | 120 | 12 | 2 | 12 | 35 | 8,6 | 1,9 |
| | 80 | 4500 | 190 | 450 | 3600 | 210 | 120 | 160 | 185 | M10 | 12 | 70 | 60 | 36 | 5 | 2,0 | 140 | 17 | 3 | 12 | 35 | 12,5 | 2,6 |
| | 90 | 5600 | 180 | 420 | 2700 | 230 | 140 | 180 | 206 | M12 | 12 | 80 | 70 | 36 | 5 | 2,5 | 165 | 22 | 3 | 12 | 35 | 17,4 | 3,0 |
| | 100 | 10500 | 200 | 455 | 2700 | 290 | 140 | 210 | 258 | M16 | 12 | 90 | 80 | 52,6 | 5 | 2,5 | 180 | 18,6 | 3 | 15 | 37 | 28 | 5,0 |
| | 130 | 15750 | 180 | 415 | 2400 | 322 | 170 | 240 | 278 | M16 | 12 | 90 | 80 | 52,6 | 5 | 3,0 | 210 | 18,6 | 3 | 15 | 37 | 35 | 6,0 |

NOTES

- $T_{max} = 2 \times T_{KN}$
» Refer to Selection page 10 to 13
 - This maximum allowable torque transmission speed n_{max} must not be exceeded when transmitting torque
 - This minimum allowable overrunning speed n_{imin} should not be reduced under continuous operation. Possible reduction of this minimum speed on request
 - Inner race overruns
Keyway to DIN 6885.1
- Cover F8 must be ordered separately
» Refer to mounting and maintenance instructions page 16 to 19
- Other bore diameters on request

MOUNTING EXAMPLE

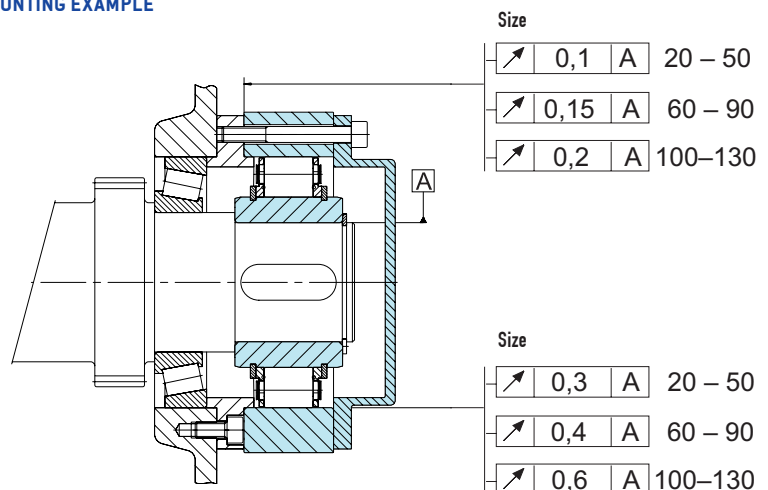

RSCI 180-300



TYPE



Type RSCI is a centrifugal lift off sprag type freewheel with the inner race rotating. Only the inner race is designed for freewheeling.

Primarily designed as a backstop, this type can be also used as an overrunning clutch in crawl drives, where the

overrunning speed is high but the driving speed is low and does not exceed the maximum driving speed shown in the table. Centering of the outer race must use the inner bore. The centering spigot must not contact the sprag cage. Please refer to page 76 (RSCI 20-130) for further information.

RSCI

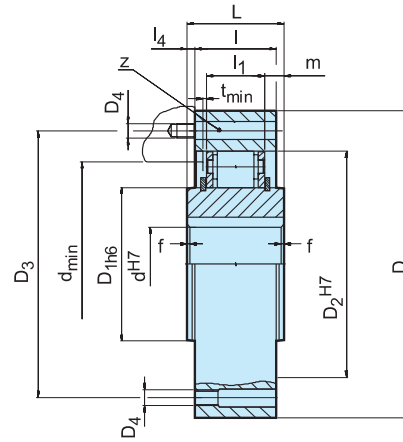

| Size | Torque | Speeds | | | Number | | | | | | | | | | Weight | | | | |
|------------------|-----------------------|--|---|---|--------|-----------|------------|-------|-------|----|-----|-----|-------|-------|---------------------|-----------|------|-----------|----------------|
| d^{H7} [mm] | $T_{KN}^{1)}$ [Nm] | $n_{max}^{2)}$ [min ⁻¹] | $n_{imin}^{3)}$ [min ⁻¹] | $n_{imax}^{4)}$ [min ⁻¹] | D | D_{1h6} | D_2^{H7} | D_3 | D_4 | z | L | l | l_1 | l_4 | $f \times 45^\circ$ | d_{min} | m | t_{min} | Weight [kg] |
| 180 | 31500 | 150 | 310 | 1300 | 412 | 240 | 310 | 360 | M20 | 12 | 90 | 80 | 53 | 5 | 3.5 | 280 | 18.6 | 3 | 59 |
| 180 M | 50000 | 115 | 260 | 1300 | 422 | 240 | 310 | 370 | M20 | 18 | 120 | 120 | 83 | 0 | 4 | 280 | 18.5 | 2 | 92 |
| 180 II | 63000 | 150 | 310 | 1300 | 412 | 240 | 310 | 360 | M20 | 24 | 160 | 160 | 118 | 0 | 3.5 | 280 | 21 | 3 | 116 |
| 180 II-M | 100000 | 115 | 260 | 1300 | 425 | 240 | 310 | 370 | M24 | 24 | 240 | 240 | 176 | 0 | 4 | 280 | 32 | 3 | 190 |
| 220 | 42500 | 135 | 290 | 1100 | 470 | 290 | 360 | 410 | M20 | 16 | 105 | 80 | 60 | 5 | 4 | 330 | 19.5 | 3 | 90 |
| 220 M | 68000 | 105 | 240 | 1100 | 480 | 290 | 360 | 410 | M24 | 16 | 120 | 120 | 83 | 0 | 4 | 330 | 18.5 | 2 | 109 |
| 220 II | 85000 | 135 | 290 | 1100 | 480 | 290 | 360 | 410 | M24 | 18 | 160 | 160 | 130 | 0 | 4 | 330 | 15 | 3 | 159 |
| 220 II-M | 136000 | 105 | 240 | 1100 | 490 | 290 | 360 | 425 | M30 | 20 | 240 | 240 | 176 | 0 | 4 | 330 | 32 | 2 | 249 |
| 240 | 52000 | 130 | 275 | 1100 | 500 | 320 | 390 | 440 | M20 | 16 | 105 | 90 | 60 | 7.5 | 4 | 360 | 15 | 2 | 95 |
| 240 M | 83000 | 100 | 225 | 1100 | 520 | 320 | 390 | 440 | M24 | 16 | 120 | 120 | 83 | 0 | 4 | 360 | 18.5 | 2 | 137 |
| 240 II | 104000 | 130 | 275 | 1100 | 505 | 320 | 390 | 440 | M24 | 24 | 180 | 180 | 132 | 0 | 4 | 360 | 24 | 2 | 191 |
| 240 II-M | 166000 | 100 | 225 | 1100 | 530 | 320 | 390 | 440 | M30 | 24 | 240 | 240 | 176 | 0 | 4 | 360 | 32 | 2 | 292 |
| 260 | 65000 | 125 | 260 | 1000 | 550 | 360 | 430 | 500 | M24 | 16 | 105 | 105 | 60 | 0 | 4 | 400 | 22.5 | 2 | 130 |
| 260 M | 100000 | 95 | 215 | 1000 | 580 | 360 | 430 | 500 | M24 | 24 | 125 | 125 | 83 | 0 | 4 | 400 | 21 | 2 | 183 |
| 260 II | 130000 | 125 | 260 | 1000 | 550 | 360 | 430 | 500 | M24 | 24 | 210 | 210 | 132 | 0 | 4 | 400 | 39 | 2 | 262 |
| 260 II-M | 200000 | 95 | 215 | 1000 | 580 | 360 | 430 | 500 | M30 | 24 | 250 | 250 | 176 | 0 | 4 | 400 | 37 | 2 | 369 |
| 300 | 78000 | 115 | 235 | 1000 | 630 | 410 | 480 | 560 | M24 | 24 | 105 | 105 | 60 | 0 | 4 | 460 | 22.5 | 3 | 174 |
| 300 M | 125000 | 90 | 205 | 1000 | 630 | 410 | 480 | 560 | M24 | 24 | 125 | 125 | 83 | 0 | 4 | 460 | 21 | 3 | 210 |
| 300 II | 156000 | 115 | 235 | 1000 | 630 | 410 | 480 | 560 | M24 | 24 | 210 | 210 | 134 | 0 | 4 | 460 | 38 | 3 | 351 |

NOTES

- $T_{max} = 2 \times T_{KN}$
» Refer to Selection page 10 to 13
- This maximum allowable torque transmission speed n_{max} must not be exceeded when transmitting torque
- This minimum allowable overrunning speed n_{imin} should not be reduced under continuous operation.
Possible reduction of this minimum speed on request
- Inner race overruns
Keyway to DIN 6885.1

Cover F8 must be ordered separately
» Refer to mounting and maintenance instructions page 16 to 19

Other bore diameters on request

MOUNTING EXAMPLE

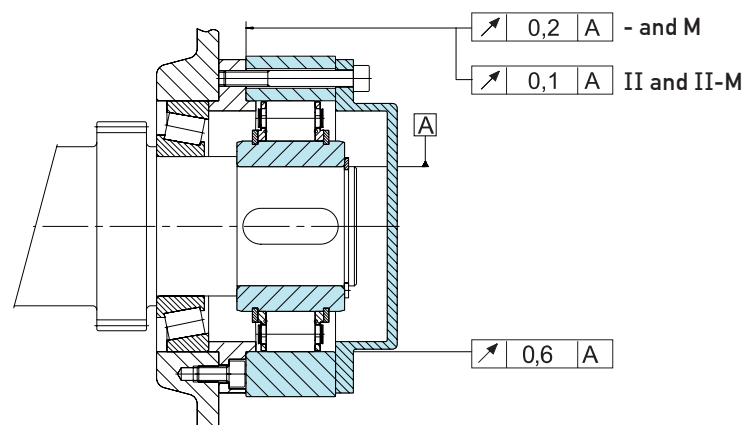

RIZ RINZ



TYPE

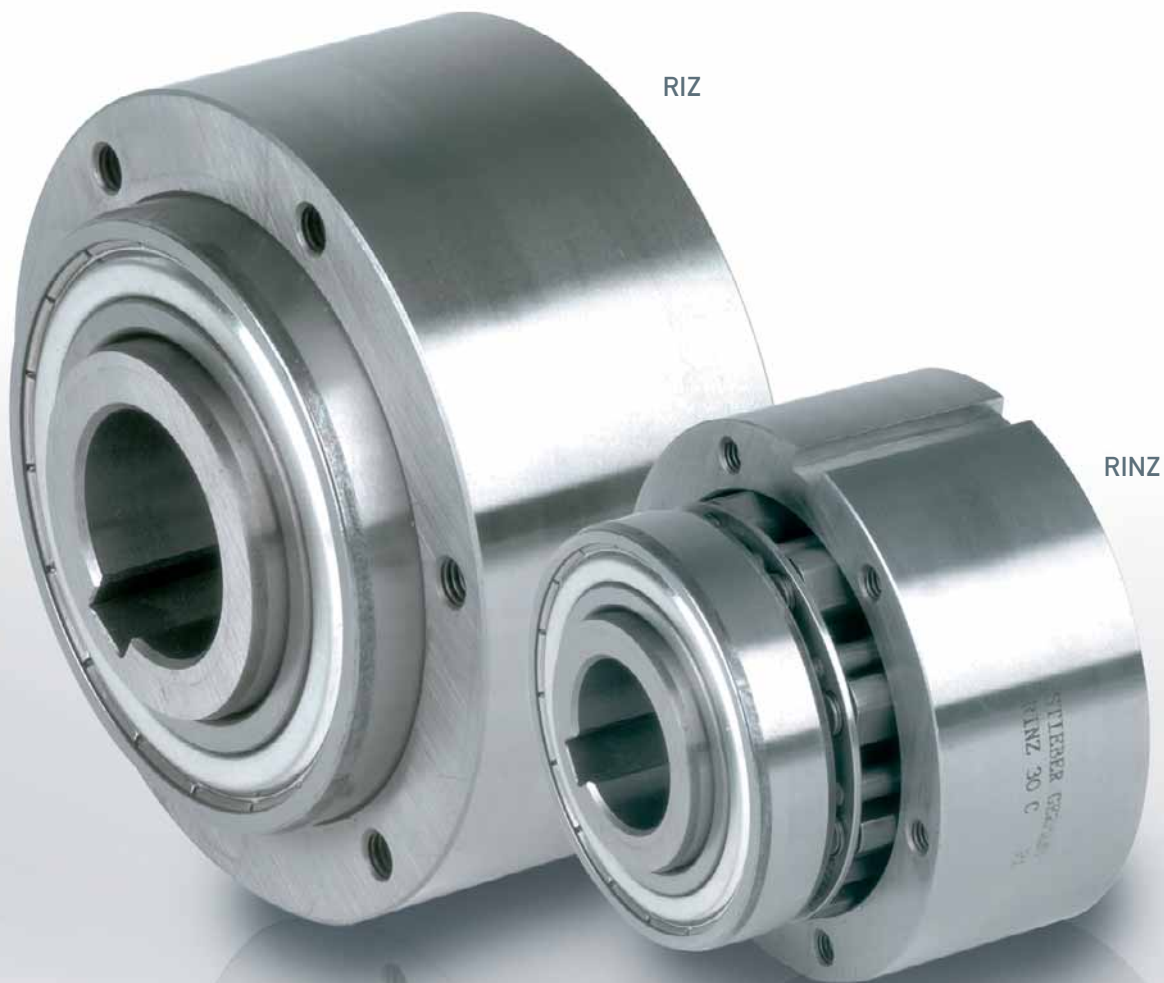

Types RIZ, RINZ are centrifugal lift off sprag type freewheels with the inner race rotating. Suitable for backstop, or overrunning clutch applications. Only the inner race is designed for freewheeling.

These units are part of the Stieber modular system. They are bearing supported using series 60.. bearings, grease lubricated and fitted with ZZ seals. Units are delivered as standard lubricated with grease and ready to

install in either a horizontal or vertical position. Types RIZ, RINZ are designed to be used with G series covers (see following pages) but if the unit is to be installed inside a housing where oil lubrication is available, please specify type RIW, RIWN.

The F series covers from type GFR, GFRN are then used without shaft seals. The following pages give further important information for use of this type unit

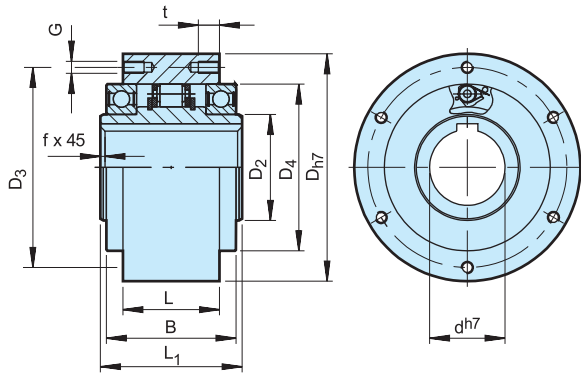

RIZ

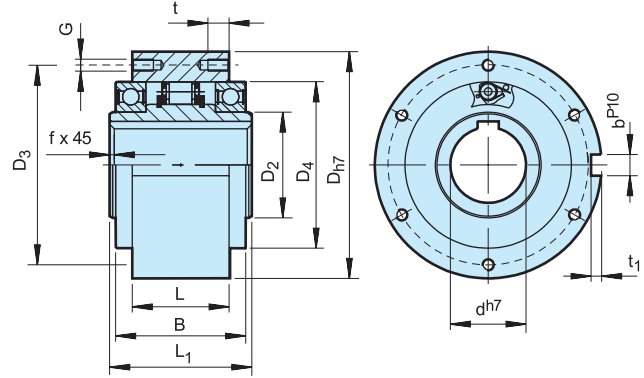

RINZ

| Type | Size | Speeds | | | | | Number | | | | | | | | | | | | | Weight |
|-------------|------|-----------------------|--|---|---|------------------|---------------|---------------|---------------|-----|----|---------------|-----------|-----------|-----------|-----------|---------------|-------------------|------|--------|
| | | $T_{KN}^{1)}$ [Nm] | $n_{max}^{2)}$ [min ⁻¹] | $n_{imin}^{3)}$ [min ⁻¹] | $n_{imax}^{4)}$ [min ⁻¹] | D_{h7} [mm] | D_2 [mm] | D_4 [mm] | D_3 [mm] | G | z | L_1 [mm] | L [mm] | B [mm] | t [mm] | f [mm] | t_1 [mm] | b^{P10} [mm] | [kg] | |
| RIZ RINZ | 30 | 375 | 350 | 780 | 9000 | 100 | 45 | 75 | 87 | M6 | 6 | 68 | 43 | 60 | 10 | 1.0 | 4 | 8 | 2.3 | |
| | 35 | 550 | 320 | 740 | 8500 | 110 | 50 | 80 | 96 | M6 | 6 | 74 | 45 | 63 | 12 | 1.0 | 5 | 10 | 3.2 | |
| | 40 | 800 | 315 | 720 | 7500 | 125 | 55 | 90 | 108 | M8 | 6 | 86 | 53 | 73 | 14 | 1.5 | 5 | 12 | 4.8 | |
| | 45 | 912 | 285 | 665 | 6600 | 130 | 60 | 95 | 112 | M8 | 8 | 86 | 53 | 73 | 14 | 1.5 | 5.5 | 14 | 5.0 | |
| | 50 | 1400 | 265 | 610 | 6000 | 150 | 70 | 110 | 132 | M8 | 8 | 94 | 64 | 86 | 14 | 1.5 | 5.5 | 14 | 7.5 | |
| | 60 | 2350 | 200 | 490 | 5300 | 170 | 80 | 125 | 150 | M10 | 10 | 114 | 78 | 105 | 16 | 2.0 | 7 | 18 | 12.7 | |
| | 70 | 3050 | 210 | 480 | 4100 | 190 | 90 | 140 | 165 | M10 | 10 | 134 | 95 | 124 | 16 | 2.5 | 7.5 | 20 | 14.5 | |
| | 80 | 4500 | 190 | 450 | 3600 | 210 | 105 | 160 | 185 | M10 | 10 | 144 | 100 | 124 | 16 | 2.5 | 9 | 22 | 19.0 | |
| | 90 | 5600 | 180 | 420 | 2700 | 230 | 120 | 180 | 206 | M12 | 10 | 158 | 115 | 143 | 20 | 3.0 | 9 | 25 | 29.5 | |
| | 100 | 10500 | 200 | 455 | 2700 | 270 | 140 | 210 | 240 | M16 | 10 | 182 | 120 | 153 | 24 | 3.0 | 10 | 28 | 42.5 | |
| | 130 | 15750 | 180 | 415 | 2400 | 310 | 160 | 240 | 278 | M16 | 12 | 212 | 152 | 194 | 24 | 3.0 | 11 | 32 | 70 | |

NOTES

- 1) $T_{max} = 2 \times T_{KN}$
» Refer to Selection page 10 to 13
 - 2) This maximum allowable torque transmission speed n_{max} must not be exceeded when transmitting torque
 - 3) This minimum allowable overrunning speed n_{imin} should not be reduced under continuous operation. Possible reduction of this minimum speed on request
 - 4) Inner race overruns
Keyway to DIN 6885.1
- » Refer to mounting and maintenance instructions page 16 to 19

MOUNTING EXAMPLE

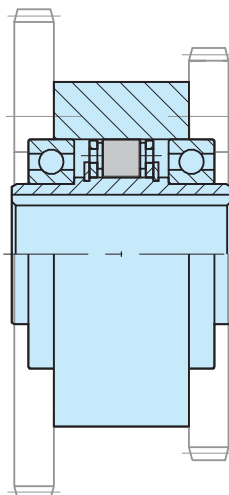

RIZ..G1G2 RIZ..G2G7 RINZ..G5G5



RIZ.. G1G2

TYPE

RIZ..G1G2

RINZ.. G5G5



Types RIZ..G1G2/G7G2, RINZ..G5G5 are centrifugal lift off sprag type freewheels with the inner race rotating. Only the inner race is designed for freewheeling.

These are self-contained units designed for overrunning clutch applications. Typically used in crawl drives, where the overrunning speed is high but the drive speed is low and does not exceed the maximum driving

speed specified in the table. They are type RIZ, RINZ (» see page 80 for more information) equipped with G type covers featuring a grease pocket and contact free seal. When ordered complete, the unit is delivered grease lubricated, ready for either horizontal or vertical installation.

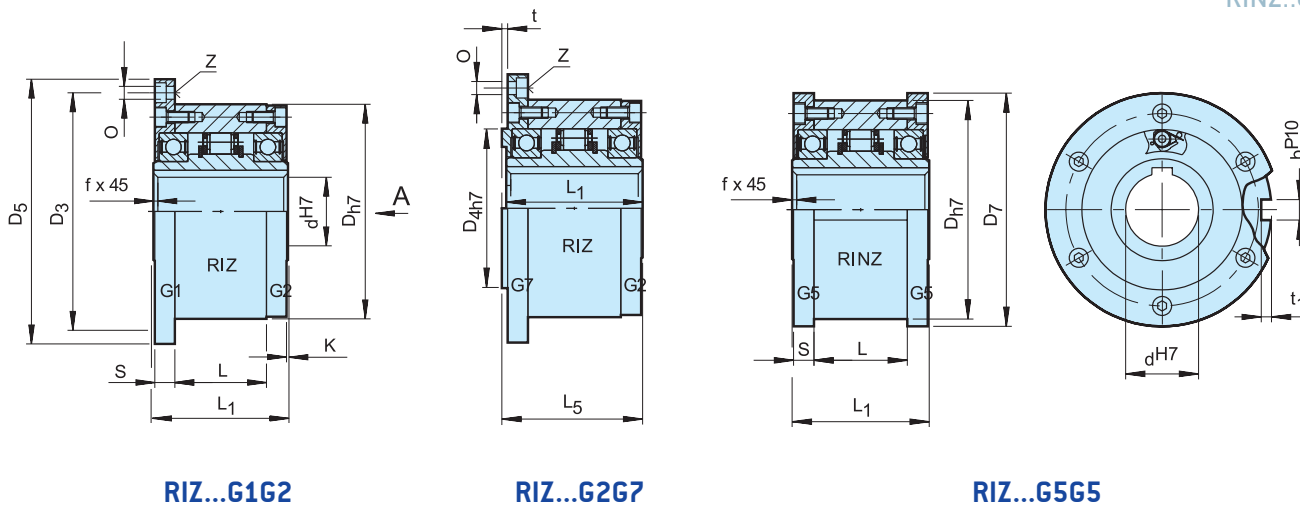

RIZ...G1G2

RIZ...G2G7

RINZ...G5G5

| Type | Size | Speeds | | | | | Number | | | | | | | | | | Weight | | | | |
|-------------|------------------|-----------------------|--|---|---|------------------|---------------|---------------|---------------|---------------|-----|----|-----------|---------------|-----------|---------------|-----------|---------------|-------------------|-----------|------------|
| RIZ RINZ | d_{H7} [mm] | $T_{KN}^{1)}$ [Nm] | $n_{max}^{2)}$ [min ⁻¹] | $n_{imin}^{3)}$ [min ⁻¹] | $n_{imax}^{4)}$ [min ⁻¹] | D_{H7} [mm] | D_3 [mm] | D_4 [mm] | D_5 [mm] | D_7 [mm] | 0 | z | S [mm] | L_1 [mm] | L [mm] | L_5 [mm] | t [mm] | t_1 [mm] | b^{P10} [mm] | f [mm] | G1 [kg] |
| | 30 | 375 | 350 | 780 | 9000 | 100 | 114 | 75 | 128 | 109 | 6,6 | 6 | 11,5 | 68 | 43 | 70 | 3 | 4 | 8 | 1,0 | 3,9 |
| | 35 | 550 | 320 | 740 | 8500 | 110 | 124 | 80 | 140 | 119 | 6,6 | 6 | 13,5 | 74 | 45 | 76 | 3,5 | 5 | 10 | 1,0 | 4,9 |
| | 40 | 800 | 315 | 720 | 7500 | 125 | 142 | 90 | 160 | 135 | 9 | 6 | 15,5 | 86 | 53 | 88 | 3,5 | 5 | 12 | 1,5 | 7,5 |
| | 45 | 912 | 285 | 665 | 6600 | 130 | 146 | 95 | 165 | 140 | 9 | 8 | 15,5 | 86 | 53 | 88 | 3,5 | 5,5 | 14 | 1,5 | 7,8 |
| | 50 | 1400 | 265 | 610 | 6000 | 150 | 166 | 110 | 185 | 160 | 9 | 8 | 14 | 94 | 64 | 96 | 4 | 5,5 | 14 | 1,5 | 10,8 |
| | 60 | 2350 | 200 | 490 | 5300 | 170 | 192 | 125 | 214 | 182 | 11 | 10 | 17 | 114 | 78 | 116 | 4 | 7 | 18 | 2,0 | 16,8 |
| | 70 | 3050 | 210 | 480 | 4100 | 190 | 212 | 140 | 234 | 202 | 11 | 10 | 18,5 | 134 | 95 | 136 | 4 | 7,5 | 20 | 2,5 | 20,8 |
| | 80 | 4500 | 190 | 450 | 3600 | 210 | 232 | 160 | 254 | 222 | 11 | 10 | 21 | 144 | 100 | 146 | 4 | 9 | 22 | 2,5 | 27 |
| | 90 | 5600 | 180 | 420 | 2700 | 230 | 254 | 180 | 278 | 242 | 14 | 10 | 20,5 | 158 | 115 | 160 | 4,5 | 9 | 25 | 3,0 | 40 |
| | 100 | 10500 | 200 | 455 | 2700 | 270 | 305 | 210 | 335 | 282 | 18 | 10 | 30 | 182 | 120 | 184 | 5 | 10 | 28 | 3,0 | 67 |
| | 130 | 15750 | 180 | 415 | 2400 | 310 | 345 | 240 | 380 | 322 | 18 | 12 | 29 | 212 | 152 | 214 | 5 | 11 | 32 | 3,0 | 94 |

NOTES

- $T_{max} = 2 \times T_{KN}$
» Refer to Selection page 10 to 13
- This maximum allowable torque transmission speed n_{max} must not be exceeded when transmitting torque
- This minimum allowable overrunning speed n_{imin} should not be reduced under continuous operation. Possible reduction of this minimum speed on request
- Inner race overruns
Keyway to DIN 6885.1

When ordering, please specify direction of rotation seen from arrow „A“: „R“ Inner race overruns in clockwise direction, „L“ Inner race overruns in counterclockwise direction

» Refer to mounting and maintenance instructions page 16 to 19

MOUNTING EXAMPLE

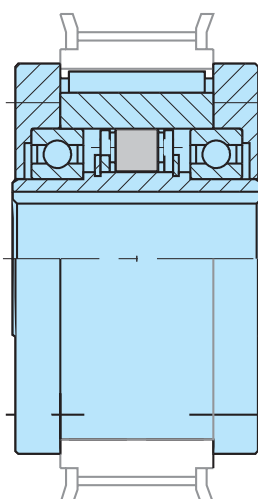

RIZ..G2G3 RIZ..G3G4



TYPE



RIZ..G2G3

RIZ..G3G4

Types RIZ..G2G3/G3G4 are centrifugal lift off sprag type freewheels with the inner race rotating. Only the inner race is designed for freewheeling.

They are self-contained units designed for backstop applications. The overrunning speed must not be less than the minimum specified in the table. This must be considered if using a variable speed drive. The torque bolt must be fitted into a slot on a fixed part of the machine.

The radial clearance should be 1–3 % of the bolt diameter. The torque arm and bearings must not be axially loaded.

They are a type RIZ. (» see page 80) equipped with G type covers featuring grease pockets and contact free seals. When ordered complete, the unit is delivered grease lubricated, ready for either horizontal or vertical installation.

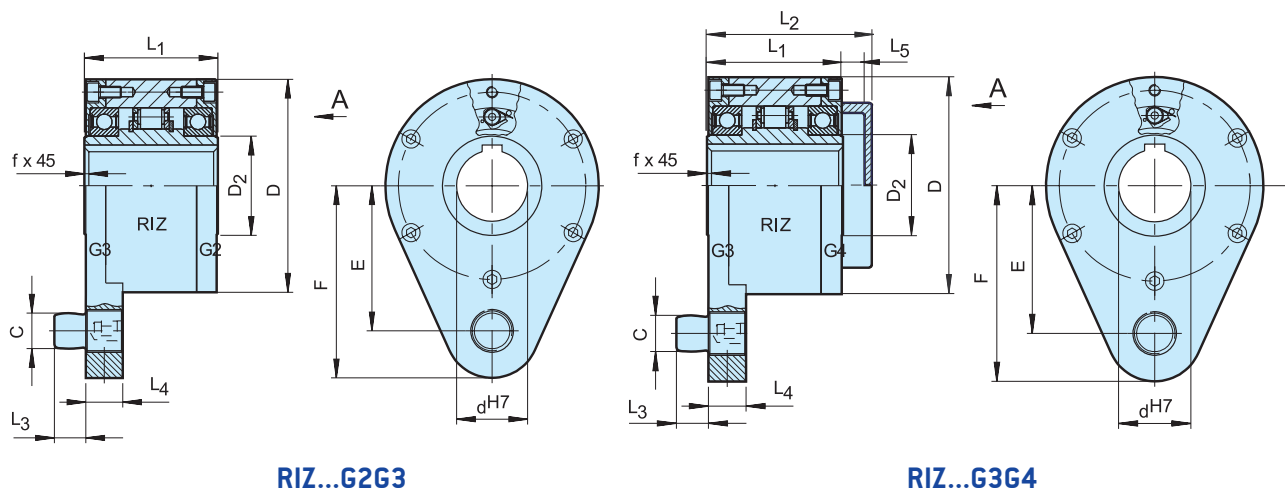

RIZ...G2G3

RIZ...G3G4

| Type | Size | Speeds | | | | | | | | | | | | | | Weight |
|------------------------|------|------------------|-----------------------|--|--|-----|----------------|-----|----------------|----------------|----------------|----------------|-----|----|----------------|--------|
| | | d^{H7} [mm] | $T_{KN}^{1)}$ [Nm] | $n_{min}^{2)}$ [min ⁻¹] | $n_{max}^{3)}$ [min ⁻¹] | D | D ₂ | C | L ₁ | L ₂ | L ₃ | L ₄ | F | E | L ₅ | |
| RIZ..G2G3 RIZ..G3G4 | 30 | 375 | 780 | 9000 | 100 | 45 | 16 | 68 | 88 | 14 | 18 | 92 | 68 | 15 | 1.0 | 4,5 |
| | 35 | 550 | 740 | 8500 | 110 | 50 | 20 | 74 | 96 | 18 | 25 | 102 | 76 | 17 | 1.0 | 5,6 |
| | 40 | 800 | 720 | 7500 | 125 | 55 | 20 | 86 | 109 | 18 | 25 | 112 | 85 | 18 | 1,5 | 8,5 |
| | 45 | 912 | 665 | 6600 | 130 | 60 | 25 | 86 | 109 | 22 | 25 | 120 | 90 | 18 | 1,5 | 8,9 |
| | 50 | 1400 | 610 | 6000 | 150 | 70 | 25 | 94 | 116 | 22 | 25 | 135 | 102 | 18 | 1,5 | 12,8 |
| | 60 | 2350 | 490 | 5300 | 170 | 80 | 32 | 114 | 139 | 25 | 30 | 145 | 112 | 20 | 2,0 | 19,3 |
| | 70 | 3050 | 480 | 4100 | 190 | 90 | 38 | 134 | 168 | 30 | 35 | 175 | 135 | 26 | 2,5 | 23,5 |
| | 80 | 4500 | 450 | 3600 | 210 | 105 | 38 | 144 | 178 | 30 | 35 | 185 | 145 | 26 | 2,5 | 32 |
| | 90 | 5600 | 420 | 2700 | 230 | 120 | 50 | 158 | 192 | 40 | 45 | 205 | 155 | 26 | 3,0 | 47,2 |
| | 100 | 10500 | 455 | 2700 | 270 | 140 | 50 | 182 | 217 | 40 | 45 | 230 | 180 | 26 | 3,0 | 76 |
| | 130 | 15750 | 415 | 2400 | 310 | 160 | 68 | 212 | 250 | 55 | 60 | 268 | 205 | 28 | 3,0 | 110 |

NOTES

- 1) $T_{max} = 2 \times T_{KN}$
» Refer to Selection page 10 to 13
- 2) This minimum allowable overrunning speed n_{imi} should not be reduced under continuous operation.
Possible reduction of this minimum speed on request.
- 3) Inner race overruns
Keyway to DIN 6885.1

When ordering, please specify direction of rotation seen from arrow „A“: „R“ Inner race overruns in clockwise direction, „L“ Inner race overruns in counterclockwise direction

» Refer to mounting and maintenance instructions page 16 to 19

MOUNTING EXAMPLE

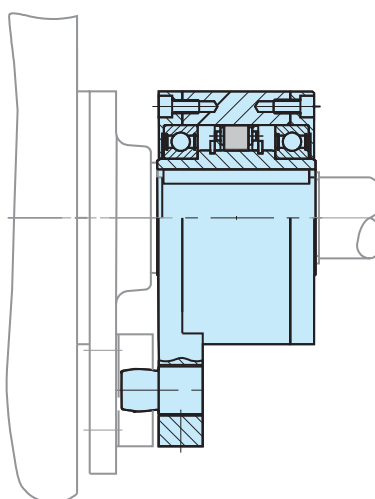

RIZ..ELG2



TYPE



Type RIZ..ELG2 is a centrifugal lift off sprag type freewheel when the inner race is overrunning. Only this race is designed for freewheeling. It is a self-contained unit designed for overrunning clutch applications.

Typically used in crawl drives where the overrunning speed is high, but the drive speed is low and does not exceed the maximum driving speed specified in the table. It is a type RIZ (» see page 80 for further information) equipped with an EL elastic coupling and a cover G2.

The EL type is a high performance coupling used to damp torsional vibrations and to accept misalignment without excess bearing load.

The inner race must overrun and will be connected to the driven machine shaft. When ordered complete, the unit is delivered grease lubricated, ready for either horizontal or vertical installation. The torques given in the table are determined by the freewheel capacity.

RIZ..ELG2

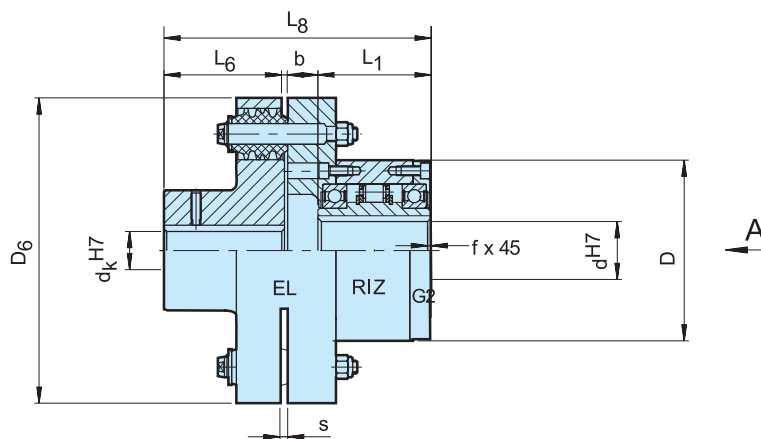

| Type | Size | EL | T_{KN} (Nm) | Speeds | | | d_K^{H7} (mm) | D (mm) | L_1 (mm) | D_6 (mm) | L_6 (mm) | L_8 (mm) | b (mm) | s (mm) | f (mm) | Weight (kg) |
|-----------|------|----|------------------|----------------------------------|----------------------------------|----------------------------------|--------------------|-----------|---------------|---------------|---------------|---------------|-----------|-----------|-----------|----------------|
| | | | | $n_{max}^{1)}$ (min^{-1}) | $n_{min}^{2)}$ (min^{-1}) | $n_{max}^{3)}$ (min^{-1}) | | | | | | | | | | |
| RIZ..ELG2 | 30 | 5 | 375 | 350 | 780 | 9000 | 20...55 | 100 | 68 | 160 | 60 | 147,5 | 19,5 | 2 | 1 | 11 |
| | 35 | 6 | 550 | 320 | 740 | 8500 | 25...75 | 110 | 74 | 190 | 75 | 166,5 | 17,5 | 2 | 1 | 17 |
| | 40 | 6 | 800 | 315 | 720 | 7500 | 25...75 | 125 | 86 | 190 | 75 | 176,5 | 15,5 | 2 | 1,5 | 19 |
| | 45 | 6 | 912 | 285 | 665 | 6600 | 25...75 | 130 | 86 | 190 | 75 | 176,5 | 15,5 | 2 | 1,5 | 19 |
| | 50 | 7 | 1400 | 265 | 610 | 6000 | 30...85 | 150 | 94 | 225 | 90 | 208,5 | 24,5 | 2,5 | 1,5 | 31 |
| | 60 | 8 | 2350 | 200 | 490 | 5300 | 35...100 | 170 | 114 | 270 | 100 | 244 | 30 | 3 | 2 | 49 |
| | 70 | 10 | 3050 | 210 | 480 | 4100 | 45...120 | 190 | 134 | 340 | 140 | 312,5 | 38,5 | 3 | 2,5 | 90 |
| | 80 | 11 | 4500 | 190 | 450 | 3600 | 55...145 | 210 | 144 | 380 | 160 | 340 | 36 | 3 | 2,5 | 107 |
| | 90 | 12 | 5600 | 180 | 420 | 2700 | 65...165 | 230 | 158 | 440 | 180 | 388 | 50 | 3,5 | 3 | 170 |
| | 100 | 14 | 10500 | 200 | 455 | 2700 | 75...170 | 270 | 182 | 500 | 200 | 422,5 | 40,5 | 3,5 | 3 | 230 |
| | 130 | 16 | 15750 | 180 | 415 | 2400 | 85...180 | 310 | 212 | 560 | 220 | 482 | 50 | 4 | 3 | 330 |

NOTES

- 1) Inner race overruns
This maximum allowable torque transmission speed n_{max} must not be exceeded when transmitting torque
- 2) This minimum allowable overrunning speed n_{min} should not be reduced under continuous operation.
Possible reduction of this minimum speed on request
- 3) Inner race overruns
Keyway to DIN 6885.1

When ordering, please specify d_K bore diameter and direction of rotation seen from arrow „A“: „R“ Inner race overruns in clockwise direction, „L“ Inner race overruns in counterclockwise direction

» Refer to mounting and maintenance instructions page 16 to 19

MOUNTING EXAMPLE

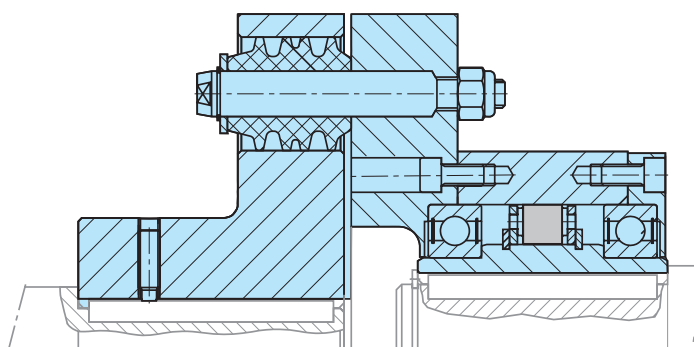

RIZ..ESG2



TYPE



Type RIZ..ESG2 is a centrifugal lift off sprag type freewheel when the inner race is overrunning. Only this race is designed for freewheeling.

It is a self-contained unit designed for overrunning clutch applications. Typically used in crawl drives where the overrunning speed is high, but the drive speed is low and does not exceed the maximum driving speed specified in the table.

It is a type RIZ (» see page 80 for further information) equipped with an ES elastic coupling and a cover G2. The ES type is a rugged coupling, economical and suitable for many applications.

The inner race must overrun and will be connected to the driven machine shaft. When ordered complete, the unit is delivered grease lubricated, ready for either horizontal or vertical installation.

Coupling half: keyway tolerance P9

RIZ..ESG2

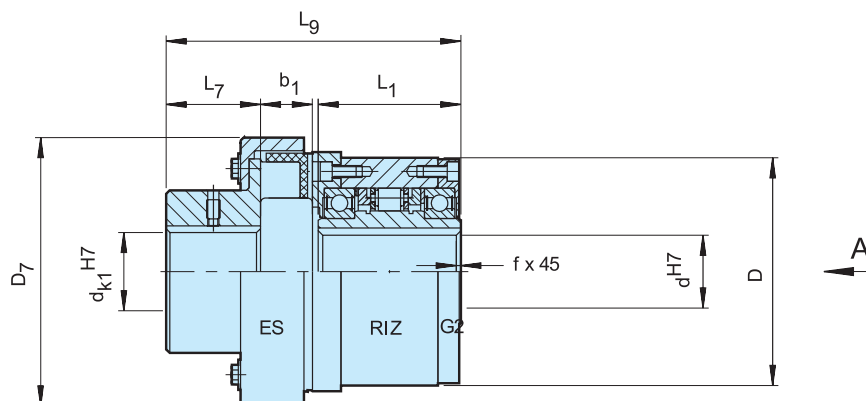

| Type | Size | ES | T_{KN} (Nm) | Speeds | | | d_{k1}^{H7} (mm) | D (mm) | L_1 (mm) | D_7 (mm) | L_7 (mm) | L_9 (mm) | b_1 (mm) | Weight (kg) |
|-----------|------------------|------|------------------|----------------------------------|----------------------------------|----------------------------------|-----------------------|-----------|---------------|---------------|---------------|---------------|---------------|----------------|
| | d^{H7} (mm) | | | $n_{max}^{1)}$ (min^{-1}) | $n_{min}^{2)}$ (min^{-1}) | $n_{max}^{3)}$ (min^{-1}) | | | | | | | | |
| RIZ..ESG2 | 30 | 10 | 80 | 350 | 780 | 9000 | 10.. 45 | 100 | 68 | 114 | 48 | 133,5 | 17 | 5,0 |
| | 35 | 16 | 250 | 320 | 740 | 8500 | 10.. 50 | 110 | 74 | 127 | 52 | 143,5 | 19 | 6,6 |
| | 40 | 25 | 400 | 315 | 720 | 7500 | 15.. 55 | 125 | 86 | 143 | 57 | 163,5 | 22 | 9,9 |
| | 45 | 40 | 625 | 285 | 665 | 6600 | 20.. 60 | 130 | 86 | 158 | 61 | 171,5 | 26 | 11,3 |
| | 50 | 63 | 1000 | 265 | 610 | 6000 | 20.. 70 | 150 | 94 | 181 | 67 | 194 | 30 | 16,7 |
| | 60 | 100 | 1600 | 200 | 490 | 5300 | 25.. 75 | 170 | 114 | 202 | 75 | 227 | 35 | 24,0 |
| | 70 | 160 | 2500 | 210 | 480 | 4100 | 30.. 80 | 190 | 134 | 230 | 82 | 261,5 | 41 | 32,5 |
| | 80 | 250 | 4000 | 190 | 450 | 3600 | 35.. 90 | 210 | 144 | 257 | 89 | 285 | 47 | 44,2 |
| | 90 | 400 | 5600 | 180 | 420 | 2700 | 45.. 100 | 230 | 158 | 294 | 97 | 319,5 | 56 | 65 |
| | 100 | 630 | 9500 | 200 | 455 | 2700 | 60.. 120 | 270 | 182 | 330 | 116 | 361 | 64 | 105 |
| | 130 | 1000 | 15750 | 180 | 415 | 2400 | 75.. 140 | 310 | 212 | 378 | 140 | 417 | 75 | 163 |

NOTES

- 1) This maximum allowable torque transmission speed n_{max} must not be exceeded when transmitting torque
- 2) Inner race
This minimum allowable overrunning speed n_{min} should not be reduced under continuous operation.
Possible reduction of this minimum speed on request
- 3) Inner race
Keyway to DIN 6885.11

When ordering, please specify d_k bore diameter and direction of rotation seen from arrow „A“: „R“ Inner race overruns in clockwise direction. „L“ Inner race overruns in counterclockwise direction

» Refer to mounting and maintenance instructions page 16 to 19

MOUNTING EXAMPLE

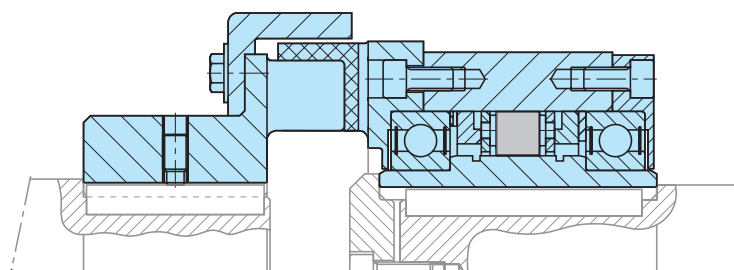

SPECIAL DESIGNS: ANYTHING IS POSSIBLE.



Stainless steel indexing clutch
for use in the food processing industry

Self-contained freewheels CSK..P
and roller chain sprocket assembly

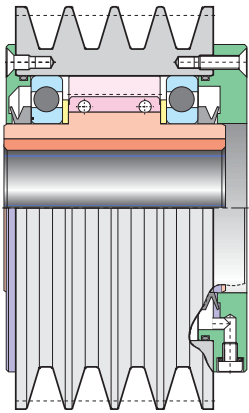
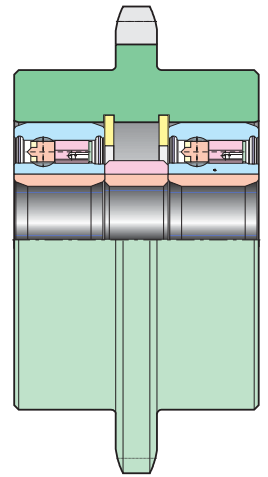

Self-contained freewheel
and v-belt pulley assembly

High performance indexing clutch
for use on an offset printing machine



Indexing clutch and
backstop combination for
high voltage switch-gear



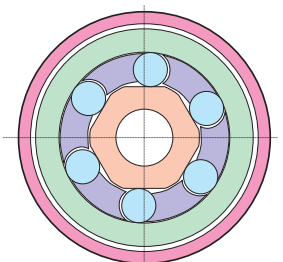
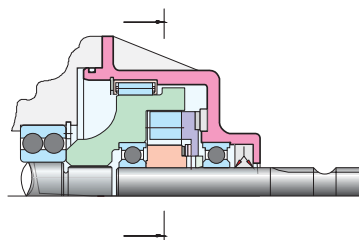

Overrunning clutch for two directions
of rotation, automatic change of direction



ALPHABETICAL LIST: QUALITY FROM A TO Z.

| | | | | | | | |
|----------|-----------------------|----------|----------------------|----------|--------------------|----------|------------------------|
| A | AA..... 36 | C | CSK/CSK..P..... 22 | G | GFK..... 26 | R | RINZ..G5G5..... 82 |
| | AE..... 34 | | CSK..2RS..... 20 | | GFR/GFRN..... 62 | | RIZ/RINZ..... 80 |
| | AL/ALP..... 52 | | CSK..P-2RS..... 22 | | GFR..F1F2..... 64 | | RIZ..ELG2..... 86 |
| | AL..F2D2/F4D2... 54 | | | | GFR..F2F3..... 66 | | RIZ..ESG2..... 88 |
| | AL..G..... 74 | D | DC..... 42 | | GFR..F2F7..... 64 | | RIZ..G1G2/..G2G7... 82 |
| | AL..KEED2..... 58 | | DC-Races..... 44 | | GFR..F3F4..... 66 | | RIZ..G2G2/..G3G4... 84 |
| | AL..KMSD2..... 60 | F | | | GFRN..F5F6..... 64 | | RSBW..... 48 |
| | ALP../ALMP..F7D7.. 56 | | FS/FSO/HPI..... 72 | K | | | RSCI..... 76 |
| | AS (NSS)..... 30 | | FSO/FSO-GR/HPI... 70 | | KI..... 28 | | RSCI 180-300..... 78 |
| | ASK..... 24 | | | N | | | |
| | ASNU (NFS)..... 32 | | | | NF..... 38 | S | S200..... 40 |
| | AV..... 50 | | | | NFR..... 46 | | SMZ..... 68 |

| | |
|---|--------------------------------|
|  | Combined bearing/freewheel |
|  | Built-in freewheels |
|  | Self-contained freewheels |
|  | Centrifugally plift off sprags |

NEW PRODUCT NAMES

The table overleaf gives the status of Stieber designations not listed in the catalogue.

| Designation | Status |
|-------------|-----------------------------|
| ALB..M | on request |
| ALZ | on request |
| ANG/ANR | superseded through NFR |
| BAT/BATS | still available |
| CLA | superseded through RIW, RIZ |
| CLV | still available |
| CR | still available |
| CRA | superseded through RSCI |
| CRLA | superseded through RIW, RIZ |

| Designation | Status |
|-------------|-------------------------------|
| BW-cages | superseded through DC.. cages |
| ETK | still available |
| KK | superseded through CSK |
| NFS | superseded through ASNU |
| NSS | superseded through AS |
| RIW | still available. See also RIZ |
| RSBF | still available up to size 70 |
| RSBI | superseded through RSCI |

Stieber GmbH

www.stieber.de // sales@stieber.de



Hatschekstraße 36
69126 Heidelberg
Fon +49(0)6221.30470
Fax +49(0)6221.304731

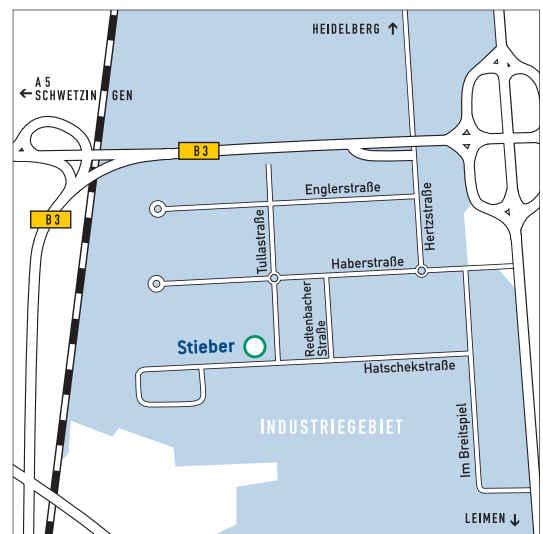

Dieselstraße 14
85748 Garching
Fon +49(0)89.329010
Fax +49(0)89.32901124

