

Rolling bearings

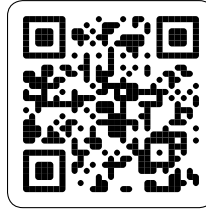

SKF mobile apps

SKF mobile apps are available from both Apple App Store and Google Play. These apps provide useful information and allow you to make critical calculations, providing SKF Knowledge Engineering at your fingertips.



Apple AppStore

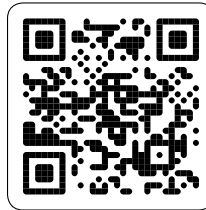

Google Play

© SKF, Duoflex, CARB, ICOS, INSOCOAT, KMT, KMTA, Monoflex, Multiflex, NoWear, SensorMount, SKF Explorer, SYSTEM 24 and Wave are registered trademarks of the SKF Group.

™ AMP Superseal 1.6 Series is a trademark of the TE connectivity family of companies

Apple is a trademark of Apple Inc., registered in the US and other countries.

Google Play is a trademark of Google Inc.

© SKF Group 2013

The contents of this publication are the copyright of the publisher and may not be reproduced (even extracts) unless prior written permission is granted. Every care has been taken to ensure the accuracy of the information contained in this publication but no liability can be accepted for any loss or damage whether direct, indirect or consequential arising out of the use of the information contained herein.

PUB BU/P1 10000/2 EN · August 2013

This publication supersedes publications 6000 EN, 6000/I EN, PUB PSD/P1 06003 EN, PUB BU/P1 10000 EN and PUB BU/P1 10000/1 EN.

Certain image(s) used under license from Shutterstock.com

Notice

For important updates and changes to this catalogue, go to skf.com/10k

Rolling bearings



Rolling bearings

Unit conversions	8
Foreword	9
This is SKF	14
SKF – the knowledge engineering company	16
Principles of bearing selection and application	18
A Bearing basics	21
Selecting rolling bearings	22
Terminology	23
Bearing types and designs	26
Boundary dimensions	40
Basic bearing designation system	42
Basic selection criteria	46
B Selecting bearing size	61
A systems approach to bearing selection	62
Bearing life and load ratings	63
Selecting bearing size using the life equations	64
Dynamic bearing loads	84
Selecting bearing size using static load carrying capacity	87
Calculation examples	90
SKF calculation tools	92
SKF Engineering Consultancy Services	94
SKF life testing	95
C Friction	97
Estimating the frictional moment	98
The SKF model for calculating the frictional moment	99
Starting torque	114
Power loss and bearing temperature	114
D Speeds	117
Basics of bearing speed	118
Reference speed	118
Limiting speed	126
Special cases	127
Vibration generation at high speeds	128

E	Bearing specifics	131
	Dimensions	132
	Tolerances	132
	Bearing internal clearance	149
	Materials for rolling bearings	150
F	Design considerations	159
	Bearing systems	160
	Radial location of bearings	165
	Axial location of bearings	204
	Design of associated components	210
	Selecting internal clearance or preload	212
	Sealing solutions	226
G	Lubrication	239
	Basics of lubrication	240
	Grease lubrication	242
	Lubricating greases	244
	SKF greases	249
	Relubrication	252
	Relubrication procedures	258
	Oil lubrication	262
H	Mounting, dismounting and bearing care	271
	General	272
	Mounting	275
	Dismounting	285
	Bearing storage	291
	Inspection and cleaning	291
	Product data	292
1	Deep groove ball bearings	295
	Product tables	
	1.1 Single row deep groove ball bearings	322
	1.2 Capped single row deep groove ball bearings	346
	1.3 ICOS oil sealed bearing units	374
	1.4 Single row deep groove ball bearings with a snap ring groove	376
	1.5 Single row deep groove ball bearings with a snap ring and shields	382
	1.6 Stainless steel deep groove ball bearings	386
	1.7 Capped stainless steel deep groove ball bearings	394
	1.8 Single row deep groove ball bearings with filling slots	410
	1.9 Single row deep groove ball bearings with filling slots and a snap ring	414
	1.10 Double row deep groove ball bearings	416
2	Y-bearings (insert bearings)	421
	Product tables	
	2.1 Y-bearings with grub screws, metric shafts	458
	2.2 Y-bearings with grub screws, inch shafts	460
	2.3 Y-bearings with an eccentric locking collar, metric shafts	464
	2.4 Y-bearings with an eccentric locking collar, inch shafts	466
	2.5 SKF ConCentra Y-bearings, metric shafts	468
	2.6 SKF ConCentra Y-bearings, inch shafts	469

2.7	Y-bearings with a tapered bore on an adapter sleeve, metric shafts	470
2.8	Y-bearings with a tapered bore on an adapter sleeve, inch shafts	471
2.9	Y-bearings with a standard inner ring, metric shafts	472
3	Angular contact ball bearings	475
	Product tables	
3.1	Single row angular contact ball bearings	506
3.2	Double row angular contact ball bearings	522
3.3	Capped double row angular contact ball bearings	526
3.4	Four-point contact ball bearings	530
4	Self aligning ball bearings	537
	Product tables	
4.1	Self-aligning ball bearings	552
4.2	Sealed self-aligning ball bearings	560
4.3	Self-aligning ball bearings with an extended inner ring	562
4.4	Self-aligning ball bearings on an adapter sleeve	564
5	Cylindrical roller bearings	567
	Product tables	
5.1	Single row cylindrical roller bearings	604
5.2	High-capacity cylindrical roller bearings	640
5.3	Single row full complement cylindrical roller bearings	644
5.4	Double row full complement cylindrical roller bearings	656
5.5	Sealed double row full complement cylindrical roller bearings	668
6	Needle roller bearings	673
	Product tables	
6.1	Needle roller and cage assemblies	722
6.2	Drawn cup needle roller bearings	730
6.3	Needle roller bearings with machined rings with flanges, without an inner ring	744
6.4	Needle roller bearings with machined rings with flanges, with an inner ring	758
6.5	Needle roller bearings with machined rings without flanges, without an inner ring	770
6.6	Needle roller bearings with machined rings without flanges, with an inner ring	774
6.7	Alignment needle roller bearings, without an inner ring	776
6.8	Alignment needle roller bearings with an inner ring	778
6.9	Needle roller / angular contact ball bearings	780
6.10	Needle roller / thrust ball bearings, full complement thrust bearing	784
6.11	Needle roller / thrust ball bearings, thrust bearing with a cage	786
6.12	Needle roller / cylindrical roller thrust bearings	788
6.13	Needle roller bearing inner rings	790
6.14	Needle rollers	794
7	Tapered roller bearings	797
	Product tables	
7.1	Metric single row tapered roller bearings	824
7.2	Inch single row tapered roller bearings	842
7.3	Single row tapered roller bearings with a flanged outer ring	864
7.4	Matched bearings arranged face-to-face	866

7.5	Matched bearings arranged back-to-back	872
7.6	Matched bearings arranged in tandem	876
8	Spherical roller bearings	879
	Product tables	
8.1	Spherical roller bearings	904
8.2	Sealed spherical roller bearings	928
8.3	Spherical roller bearings for vibratory applications	936
8.4	Spherical roller bearings on an adapter sleeve	940
8.5	Spherical roller bearings on a withdrawal sleeve	946
8.6	Sealed spherical roller bearings on an adapter sleeve	954
9	CARB toroidal roller bearings	957
	Product tables	
9.1	CARB toroidal roller bearings	980
9.2	Sealed CARB toroidal roller bearings	996
9.3	CARB toroidal roller bearings on an adapter sleeve	1000
9.4	CARB toroidal roller bearings on a withdrawal sleeve	1004
10	Thrust ball bearings	1009
	Product tables	
10.1	Single direction thrust ball bearings	1016
10.2	Single direction thrust ball bearings with a sphered housing washer	1026
10.3	Double direction thrust ball bearings	1030
10.4	Double direction thrust ball bearings with sphered housing washers	1034
11	Cylindrical roller thrust bearings	1037
	Product table	
11.1	Cylindrical roller thrust bearings	1048
12	Needle roller thrust bearings	1057
	Product tables	
12.1	Needle roller and cage thrust assemblies and appropriate washers	1070
12.2	Needle roller thrust bearings with a centring flange and appropriate washers ..	1074
13	Spherical roller thrust bearings	1077
	Product table	
13.1	Spherical roller thrust bearings	1090
14	Track runner bearings	1099
	Product tables	
14.1	Single row cam rollers	1126
14.2	Double row cam rollers	1128
14.3	Support rollers without flange rings, without an inner ring	1130
14.4	Support rollers without flange rings, with an inner ring	1132
14.5	Support rollers with flange rings, with an inner ring	1134
14.6	Cam followers	1140
15	Engineered products	1149
15A	Sensor bearing units	1151
	Product table	
15A.1	Motor encoder units	1166

15B	Bearings for extreme temperatures	1169
	Product tables	
15B.1	Single row deep groove ball bearings for extreme temperatures	1178
15B.2	Y-bearings for extreme temperatures, metric shafts	1182
15B.3	Y-bearings for extreme temperatures, inch shafts	1183
15C	Bearings with Solid Oil	1185
15D	SKF DryLube bearings	1191
15E	INSOCOAT bearings	1205
	Product tables	
15E.1	INSOCOAT deep groove ball bearings	1212
15E.2	INSOCOAT cylindrical roller bearings	1214
15F	Hybrid bearings	1219
	Product tables	
15F.1	Hybrid deep groove ball bearings	1230
15F.2	Sealed hybrid deep groove ball bearings	1232
15F.3	XL hybrid deep groove ball bearings	1236
15F.4	Hybrid cylindrical roller bearings	1238
15G	NoWear coated bearings	1241
15H	Polymer ball bearings	1247
	Product tables	
15H.1	Polymer single row deep groove ball bearings	1262
15H.2	Polymer thrust ball bearings	1266
16	Bearing accessories	1269
	Product tables	
16.1	Adapter sleeves for metric shafts	1290
16.2	Adapter sleeves for inch shafts	1298
16.3	Adapter sleeves with inch dimensions	1304
16.4	Withdrawal sleeves	1310
16.5	KM(L) and HM.. T lock nuts	1316
16.6	MB(L) lock washers	1318
16.7	HM(E) lock nuts	1320
16.8	MS locking clips	1324
16.9	N and AN inch lock nuts	1326
16.10	W inch lock washers	1330
16.11	PL inch locking plates	1332
16.12	KMK lock nuts with an integral locking device	1333
16.13	KMFE lock nuts with a locking screw	1334
16.14	KMT precision lock nuts with locking pins	1336
16.15	KMTA precision lock nuts with locking pins	1338
16.16	KMD precision lock nuts with axial locking screws	1340
Indexes	1342
Text index	1343
Product index	1364

Unit conversions

Unit conversions					
Quantity	Unit	Conversion			
Length	inch	1 mm	0.03937 in.	1 in.	25,40 mm
	foot	1 m	3.281 ft.	1 ft.	0,3048 m
	yard	1 m	1.094 yd.	1 yd.	0,9144 m
	mile	1 km	0.6214 mi.	1 mi.	1,609 km
Area	square inch	1 mm ²	0.00155 sq-in	1 sq-in	645,16 mm ²
	square foot	1 m ²	10.76 sq-ft	1 sq-ft	0,0929 m ²
Volume	cubic inch	1 cm ³	0.061 cu-in	1 cu-in	16,387 cm ³
	cubic foot	1 m ³	35 cu-ft	1 cu-ft	0,02832 m ³
	imperial gallon	1 l	0.22 gallon	1 gallon	4,5461 l
	US gallon	1 l	0.2642 US gallon	1 US gallon	3,7854 l
Speed, velocity	foot per second	1 m/s	3.28 ft/s	1 ft/s	0,30480 m/s
	mile per hour	1 km/h	0.6214 mph	1 mph	1,609 km/h
Mass	ounce	1 g	0.03527 oz.	1 oz.	28,350 g
	pound	1 kg	2.205 lb.	1 lb.	0,45359 kg
	short ton	1 tonne	1.1023 short ton	1 short ton	0,90719 tonne
	long ton	1 tonne	0.9842 long ton	1 long ton	1,0161 tonne
Density	pound per cubic inch	1 g/cm ³	0.0361 lb/cu-in	1 lb/cu-in	27,680 g/cm ³
Force	pound-force	1 N	0.225 lbf.	1 lbf.	4,4482 N
Pressure, stress	pounds per square inch	1 MPa	145 psi	1 psi	6,8948 × 10 ³ Pa
		1 N/mm ²	145 psi	1 psi	0,068948 bar
		1 bar	14.5 psi		
Moment	pound-force inch	1 Nm	8.85 lbf-in	1 lbf-in	0,113 Nm
Power	foot-pound per second	1 W	0.7376 ft-lbf/s	1 ft-lbf/s	1,3558 W
	horsepower	1 kW	1.36 hp	1 hp	0,736 kW
Temperature	degree	Celsius	$t_C = 0.555 (t_F - 32)$	Fahrenheit	$t_F = 1,8 t_C + 32$

Foreword

This catalogue contains the standard assortment of SKF rolling bearings typically used in industrial applications. To provide the highest levels of quality and customer service, these products are available worldwide through SKF sales channels. For information about lead times and deliveries, contact your local SKF representative or SKF Authorized Distributor.

The data in this catalogue reflect SKF's state-of-the-art technology and production capabilities as of 2012. The data contained within may differ from that shown in earlier catalogues because of redesign, technological developments, or revised calculation methods. SKF reserves the right to continually improve its products with respect to materials, design and manufacturing methods, some of which are driven by technological developments.

Getting started

This catalogue contains detailed information about standard SKF rolling bearings, several special engineered products and bearing accessories. Engineered products include motor encoder units, which can measure the speed and direction of rotation, polymer bearings and rolling bearings designed to fulfil additional requirements, such as:

- extreme temperatures
- electrical insulation
- dry lubrication
- insufficient lubrication
- rapid speed changes
- high vibration levels
- oscillating movements

The first section, which contains general technical information, is designed to help the reader select the best, most effective products

for a particular application. In this section, bearing service life, speed capabilities, friction, general design considerations and lubrication are discussed in detail. Installation and maintenance information is also included. More practical information about mounting and maintenance is provided in the *SKF bearing maintenance handbook* (ISBN 978-91-978966-4-1).

The latest developments

The main content updates compared to the previous catalogue include the addition of Y-bearings and needle roller bearings as well as the following featured products:

SKF Energy Efficient bearings

To meet the ever-increasing demand to reduce energy use, SKF has developed the SKF Energy Efficient (E2) performance class of rolling bearings. SKF E2 bearings are characterized by a frictional moment in the bearing

SKF Energy Efficient bearings are identified by the designation prefix E2.



Foreword

that is at least 30% lower when compared to a same-sized SKF standard bearing.

High-capacity cylindrical roller bearings

SKF high-capacity cylindrical roller bearings combine the high load carrying capacity of full complement bearings and the high speed capability of bearings with a cage. They are designed for applications such as industrial gearboxes, gearboxes in wind turbines and mining equipment.



SKF high-capacity cylindrical roller bearing

SKF DryLube bearings

SKF DryLube bearings are a new option for extreme temperature applications. They are filled with a dry lubricant, based on graphite and molybdenum disulfide. The dry lubricant can protect the rolling elements and raceways from damage caused by solid contaminants. SKF DryLube bearings provide effective lubrication for high temperature applications, low start-up torque at any temperature and low frictional moment during operation.



SKF DryLube bearing

Polymer ball bearings

Polymer ball bearings are an excellent solution from both a technical and economic perspective, in applications where resistance to moisture or chemicals is essential. Polymer ball bearings use bearing rings or washers made of various polymer materials and balls made of glass, stainless steel or polymers. They are lightweight, self lubricating, quiet running, and resistant to corrosion, chemicals and wear and fatigue.



Polymer ball bearing

SKF ConCentra Y-bearings (insert bearings)

The SKF ConCentra locking technology provides a true concentric fit of the bearing on a shaft, to virtually eliminate fretting corrosion. These bearings are as easy to mount as bearings with grub screw locking.



SKF ConCentra Y-bearing

Grease life calculation for capped deep groove ball bearings

Capped deep groove ball bearings and Y-bearings (insert bearings) are typically greased for life. SKF did extensive research to enable a theoretical approach to estimate the grease life depending on bearing speed, operating temperature, load and other factors.

Extended assortment for value-added bearings

The assortment of capped bearings, SKF Explorer bearings, electrically insulated bearings and hybrid bearings has been extended.

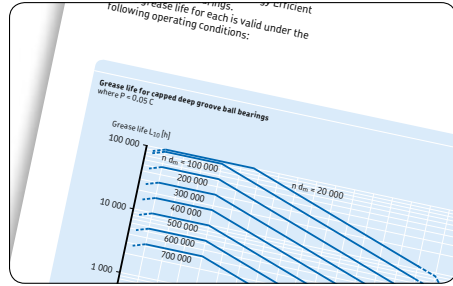

Grease life estimation for capped bearings

How to use this catalogue

This catalogue is divided into two main sections: a technical section and a product section. The technical section describes in detail how to select and apply rolling bearings and covers eight main topics marked with printed tabs from A to H. The product section is divided into chapters by product type. Each chapter contains specific information about the bearing type and its optional variants and product tables. Each product chapter is clearly marked by cut tabs with an easily identifiable icon.

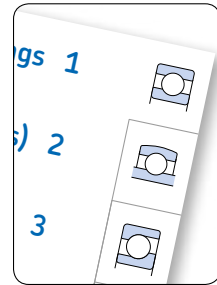
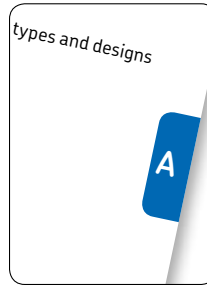

Printed and cut tabs simplify navigation

Find information quickly

The catalogue is designed so that specific information can be found quickly. At the front of the catalogue there is the full table of contents. At the back, there is a product index and a full text index.

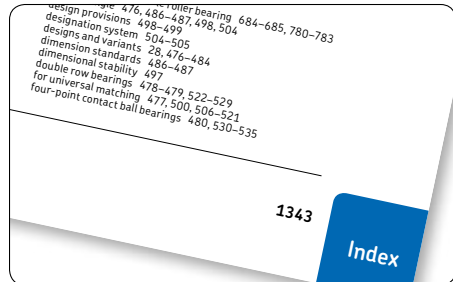

A comprehensive text index helps to locate specific information quickly.

Units of measurement

This catalogue is for global use. Therefore, the predominant units of measurement are in accordance with ISO 80000-1. Exceptionally, imperial units are used when it is required by the product. Unit conversions can be made using the conversion table (→ **page 8**).

For easier use, temperature values are provided in both, °C and °F. Temperature values are typically rounded. Therefore, the two values do not always exactly match when using the conversion formula.

More SKF rolling bearings

Other rolling bearings, not presented in this catalogue, include:

- super-precision bearings
- ball and roller bearing units
- fixed section ball bearings
- large deep groove ball bearings with filling slots
- large angular contact thrust ball bearings
- tapered roller thrust bearings
- multi-row ball or roller bearings
- split roller bearings
- crossed tapered roller bearings
- slewing bearings
- linear ball bearings
- bearings for inline skates and skateboards
- backing bearings for cluster mills
- indexing roller units for continuous furnaces of sintering plants
- application specific bearings for railway rolling stock
- application specific bearings for cars and trucks
- triple ring bearings for the pulp and paper industry
- bearings for printing press rollers
- bearings for critical aerospace applications

For information about these products, contact SKF or visit skf.com.

This is SKF

From one simple but inspired solution to a misalignment problem in a textile mill in Sweden, and fifteen employees in 1907, SKF has grown to become a global industrial knowledge leader. Over the years we have built on our expertise in bearings, extending it to seals, mechatronics, services and lubrication systems. Our knowledge network includes 46 000 employees, 15 000 distributor partners, offices in more than 130 countries, and a growing number of SKF Solution Factory sites around the world.



Research and development

We have hands-on experience in over forty industries, based on our employees' knowledge of real life conditions. In addition our world-leading experts and university partners who pioneer advanced theoretical research and development in areas including tribology, condition monitoring, asset management and bearing life theory. Our ongoing commitment to research and development helps us keep our customers at the forefront of their industries.



SKF Solution Factory makes SKF knowledge and manufacturing expertise available locally, to provide unique solutions and services to our customers.

Meeting the toughest challenges

Our network of knowledge and experience along with our understanding of how our core technologies can be combined helps us create innovative solutions that meet the toughest of challenges. We work closely with our customers throughout the asset life cycle, helping them to profitably and responsibly grow their businesses.

Working for a sustainable future

Since 2005, SKF has worked to reduce the negative environmental impact from our own operations and those of our suppliers. Our continuing technology development introduced the SKF BeyondZero portfolio of products and services which improve efficiency and reduce energy losses, as well as enable new technologies harnessing wind, solar and ocean power. This combined approach helps reduce the environmental impact both in our own operations and in our customers'.



Working with SKF IT and logistics systems and application experts, SKF Authorized Distributors deliver a valuable mix of product and application knowledge to customers worldwide.



SKF – the knowledge engineering company

Our knowledge – your success

SKF Life Cycle Management is how we combine our technology platforms and advanced services, and apply them at each stage of the asset life cycle, to help our customers to be more successful, sustainable and profitable.

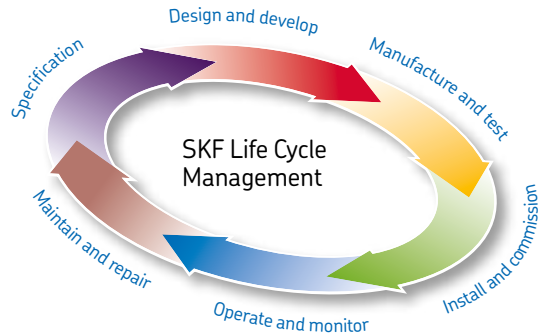

Working closely with you

Our objective is to help our customers improve productivity, minimize maintenance, achieve higher energy and resource efficiency, and optimize designs for long service life and reliability.

Innovative solutions

Whether the application is linear or rotary or a combination of the two, SKF engineers can work with you at each stage of the asset life cycle to improve machine performance by looking at the

entire application. This approach doesn't just focus on individual components like bearings or seals. It looks at the whole application to see how each component interacts with the next.

Design optimization and verification

SKF can work with you to optimize current or new designs with proprietary 3-D modeling software that can also be used as a virtual test rig to confirm the integrity of the design.



Bearings

SKF is the world leader in the design, development and manufacture of high performance rolling bearings, plain bearings, bearing units and housings.



Machinery maintenance

Condition monitoring technologies and maintenance services from SKF can help minimize unplanned downtime, improve operational efficiency and reduce maintenance costs.



Sealing solutions

SKF offers standard seals and custom engineered sealing solutions to increase uptime, improve machine reliability, reduce friction and power losses, and extend lubricant life.



Mechatronics

SKF fly-by-wire systems for aircraft and drive-by-wire systems for off-road, agricultural and forklift applications replace heavy, grease or oil consuming mechanical and hydraulic systems.



Lubrication solutions

From specialized lubricants to state-of-the-art lubrication systems and lubrication management services, lubrication solutions from SKF can help to reduce lubrication related downtime and lubricant consumption.



Actuation and motion control

With a wide assortment of products – from actuators and ball screws to profile rail guides – SKF can work with you to solve your most pressing linear system challenges.



Principles of bearing selection and application

Bearing basics	21
Selecting bearing size	61
Friction	97
Speeds	117
Bearing specifics	131
Design considerations	159
Lubrication	239
Mounting, dismounting and bearing care	271

A

B

C

D

E

F

G

H

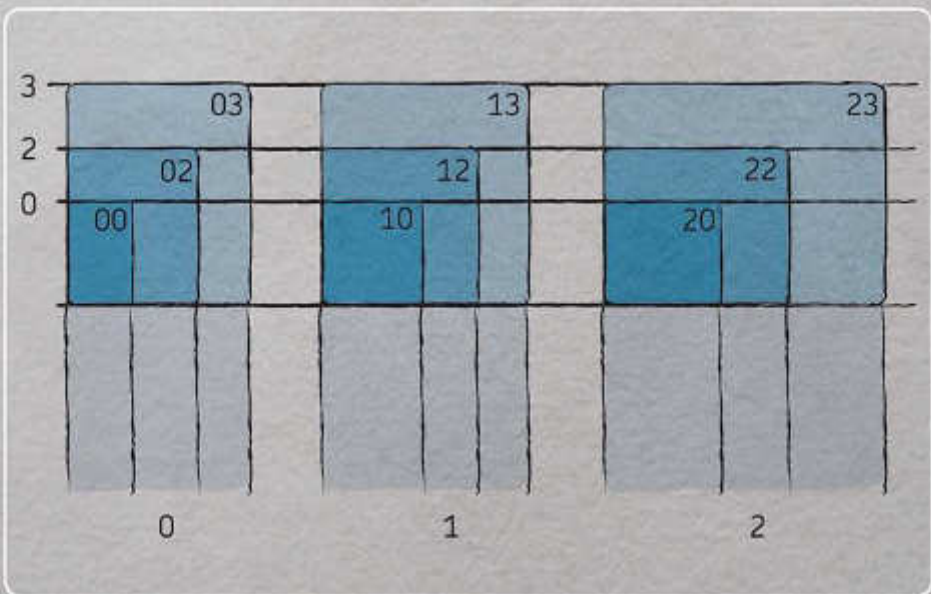

Bearing basics

A

Selecting rolling bearings	22	Basic selection criteria	46
Terminology	23	Available space	47
Symbols	23	Loads	48
Bearing systems	24	Magnitude of load	48
Radial bearings	24	Direction of load	48
Thrust bearings	25	Misalignment	52
Bearing types and designs	26	Precision	53
Radial bearings	26	Speed	53
Thrust bearings	33	Friction	54
Track runner bearings	35	Quiet running	54
Cages	37	Stiffness	54
Stamped metal cages	37	Axial displacement	55
Machined metal cages	38	Mounting and dismounting	56
Polymer cages	38	Cylindrical bore	56
Cage guidance	39	Tapered bore	56
Materials	39	Sealing solutions	58
Boundary dimensions	40		
ISO general plans	40		
General plans for inch bearings	41		
Basic bearing designation system	42		
Basic designations	42		
Prefixes and suffixes	45		
Bearing designations not covered by the basic bearing designation system	45		

Selecting rolling bearings

A bearing system consists of more than just bearings. Associated components like the shaft and housings are integral parts of the overall system. The lubricant and sealing elements also play a critical role. To maximize bearing performance, the correct amount of an appropriate lubricant must be present to reduce friction in the bearing and protect it from corrosion. Sealing elements are important, because they keep the lubricant in and contaminants out of the bearing. This is particularly important because cleanliness has a profound effect on bearing service life – which is why SKF manufactures and sells a wide range of industrial seals and lubrication systems.

There are a number of factors that go into the bearing selection process. Understanding the dynamic behaviour of the application is probably one of the most important. Dynamic behaviour, in this case, means:

- available space
- loads (magnitude and direction)
- misalignment
- precision and stiffness
- speeds
- operating temperature
- vibration levels
- contamination levels
- lubrication type and method

Once the dynamic behaviour has been established, a suitable bearing type and size can be selected. However, during the bearing selection process there are several other factors that need to be considered:

- a suitable form and design of other components of the arrangement
- appropriate fits and bearing internal clearance or preload
- holding devices
- adequate seals
- the type and quantity of lubricant
- installation and removal methods

When designing an application, every decision affects the performance, reliability and economy of the bearing system.

As the leading bearing supplier, SKF manufactures a large number of bearing types, series, designs, variants and sizes. The most common of them are introduced under *Bearing types and designs* (→ page 26). There are also bearings that are not included in this catalogue. Information about most of these bearings is provided in special catalogues or online at skf.com/bearings.

In this section and in sections B through H, the designer of a bearing system can find the necessary basic information presented in the order in which it is generally required. Obviously, it is impossible to include all the information needed to cover every conceivable application. For this reason, in many places, reference is made to the SKF application engineering service. This technical service can perform complex calculations, diagnose and solve bearing performance issues, and help with the bearing selection process. SKF also recommends this service to anyone working to improve the performance of their application.

The information contained in this section and in sections B through H is general and applies to most rolling bearings. Information specific to one bearing type is provided in the relevant product chapter. Additional catalogues and brochures covering specific application areas are available on request. Detailed information about almost all SKF rolling bearings, bearing units, housings, plain bearings and seals is available online at skf.com/bearings.

It should be noted that the values listed in the product tables for load and speed ratings as well as for the fatigue load limit are heavily rounded.

Fig. 1

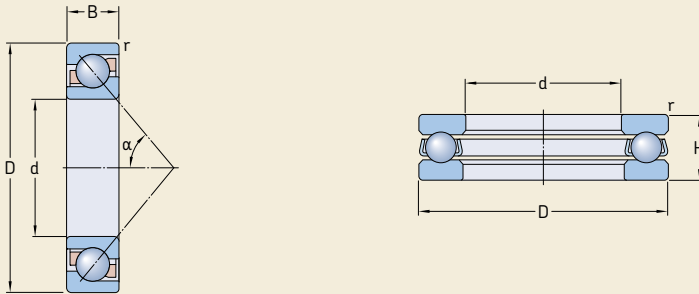

Terminology

Some frequently used bearing terms are explained here. For a detailed collection of bearing-specific terms and definitions, refer to ISO 5593 Rolling bearings – Vocabulary.

Symbols

Symbols used in this catalogue are mainly in accordance with ISO standards. Most common symbols for bearing boundary dimensions are shown in **fig. 1**. Other symbols are listed below. All symbols can be used with a subscript to identify specifications.

- A = speed factor
= $n \cdot d_m$ [mm/min]
- C = bearing load rating [kN]
- d_m = bearing mean diameter [mm]
= $0,5 (d + D)$
- F = actual bearing load [kN]
- L = life, typically in million revolutions or operating hours
- n = rotational speed [r/min]
- P = equivalent bearing load [kN]
- P_u = fatigue load limit [kN]
- η_c = factor for contamination level
- κ = viscosity ratio: actual versus required
- ν = oil viscosity [mm²/s]

Bearing systems (→ fig. 2)

- 1 Cylindrical roller bearing
- 2 Four-point contact ball bearing
- 3 Housing
- 4 Shaft
- 5 Shaft abutment shoulder
- 6 Shaft diameter
- 7 Shaft seat
- 8 End plate
- 9 Radial shaft seal
- 10 Distance ring
- 11 Housing bore diameter
- 12 Housing seat
- 13 Housing cover
- 14 Snap ring

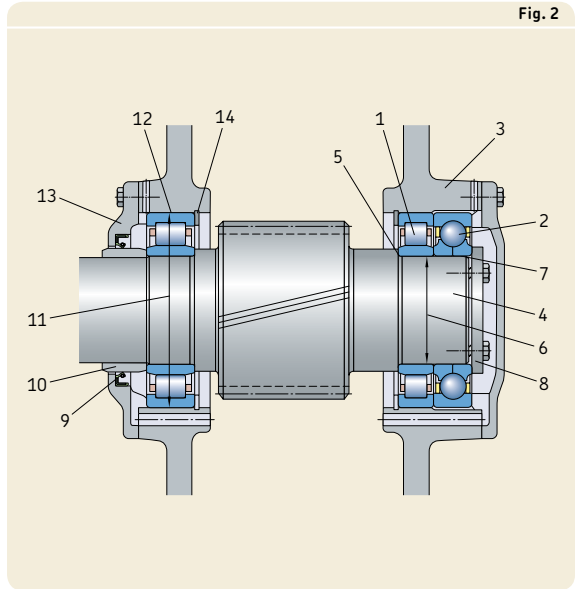

Radial bearings (→ figs. 3 and 4)

- 1 Inner ring
- 2 Outer ring
- 3 Rolling element: ball, cylindrical roller, needle roller, tapered roller, spherical roller, toroidal roller
- 4 Cage
- 5 Capping device
- 6 Seal – made of elastomer
- 7 Shield – made of sheet steel
- 8 Outer ring outside surface
- 9 Inner ring bore
- 10 Inner ring shoulder surface
- 11 Outer ring shoulder surface
- 12 Snap ring groove
- 13 Snap ring
- 14 Outer ring side face
- 15 Recess for capping device
- 16 Seal
- 17 Shield
- 18 Snap ring groove
- 19 Snap ring

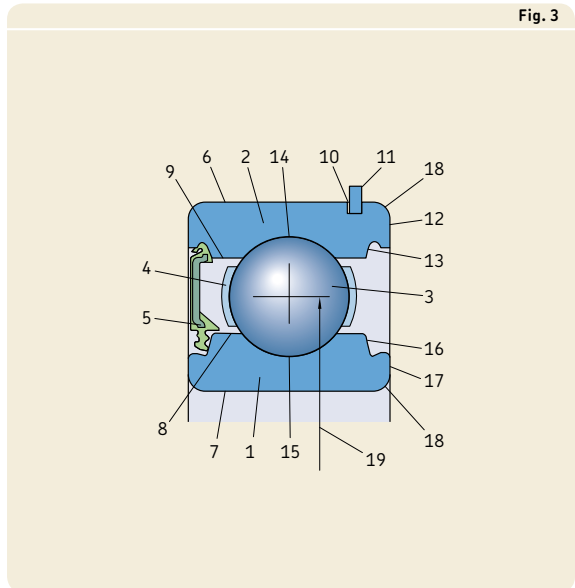

- 14 Outer ring raceway
- 15 Inner ring raceway
- 16 Recess for capping device
- 17 Inner ring side face
- 18 Chamfer
- 19 Bearing pitch circle diameter
- 20 Total bearing width
- 21 Guide flange
- 22 Retaining flange
- 23 Contact angle

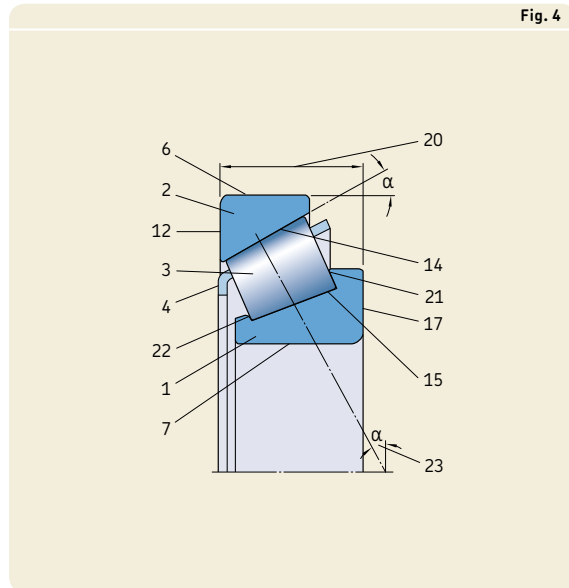

Thrust bearings (→ fig. 5)

- 24 Shaft washer
- 25 Rolling element and cage assembly
- 26 Housing washer
- 27 Housing washer with a sphered seat surface
- 28 Seat washer

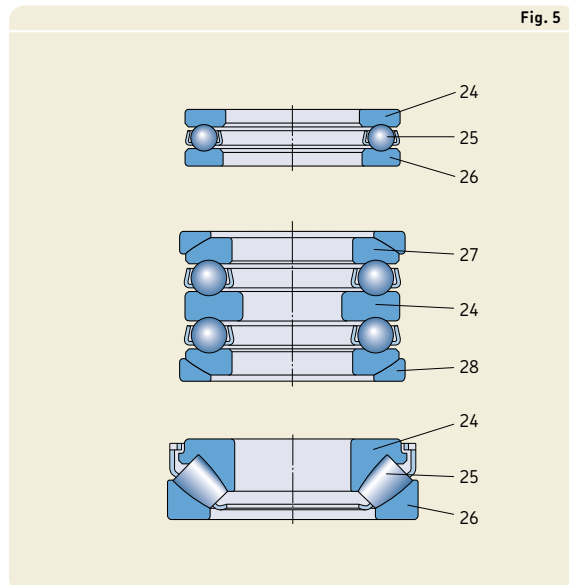

Bearing types and designs

Radial bearings

Radial bearings accommodate loads that are predominantly perpendicular to the shaft. The bearings are typically classified by the type of rolling element and shape of the raceways.

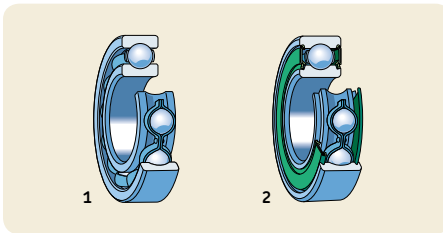

Deep groove ball bearings (→ page 295)

single row
open basic design (1)

with shields (2)

single row, stainless steel

open basic design (1)

with shields (2)

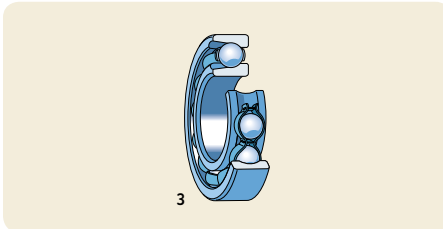

single row, with filling slots

open basic design (3)

with shields

with a snap ring groove, with or without
a snap ring

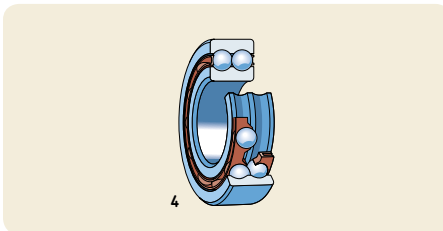

double row (4)

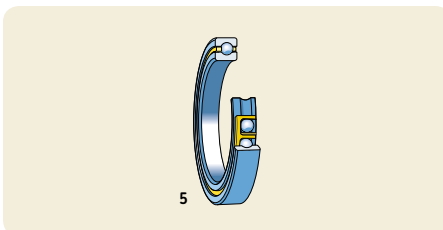

thin section bearings¹⁾

open basic design (5)

with contact seals

¹⁾ Contact the SKF application engineering service.

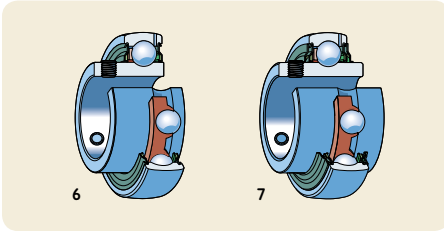

Y-bearings (insert bearings) (→ page 421)
 with grub screws
 inner ring extended on one side (6)
 inner ring extended on both sides (7)

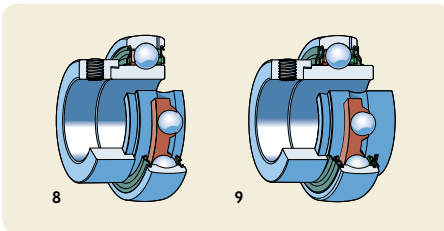

with an eccentric locking collar
 inner ring extended on one side (8)
 inner ring extended on both sides (9)

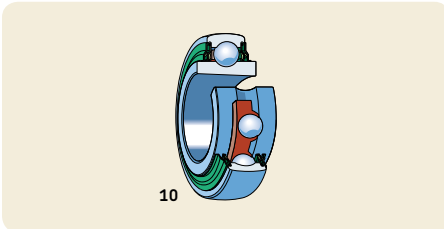

with a tapered bore
 inner ring extended on both sides,
 for adapter sleeve mounting (10)

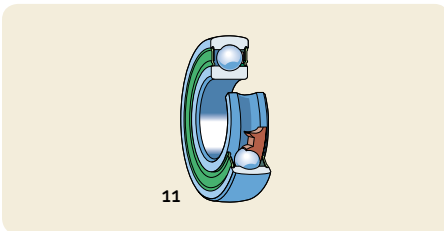

with a standard inner ring
 for locating by interference fit
 on the shaft (11)

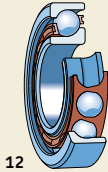

12

Angular contact ball bearings (→ page 475)

- single row
 - basic design for single mounting
 - design for universal matching (**12**)

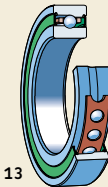

13

- super-precision single row¹⁾
 - basic design
 - open or with contact seals
 - high-speed design
 - open or with contact seals (**13**)
 - high-capacity design
 - open or with contact seals

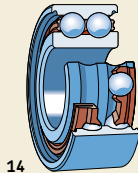

14

- double row
 - with a one-piece inner ring (**14**)
 - open basic design
 - with shields
 - with contact seals
 - with a two-piece inner ring

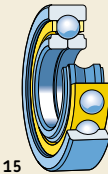

15

four-point contact ball bearings (15)



16



17

Self-aligning ball bearings (→ page 537)

- with a cylindrical or tapered bore
 - open basic design (**16**)
 - with contact seals (**17**)

¹⁾ Refer to product information available online at skf.com/super-precision or separate catalogue.

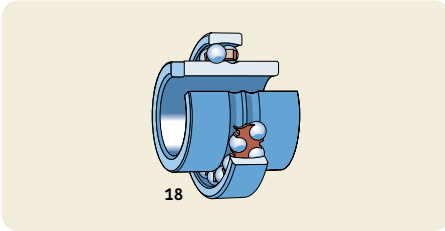

with an extended inner ring (18)

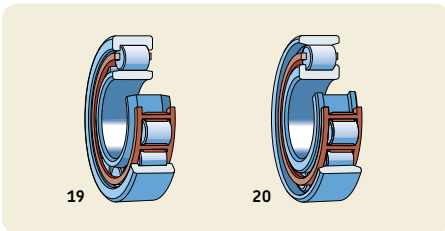

Cylindrical roller bearings (→ page 567)

single row
 NU design (19)
 with one or two angle rings
 N design (20)

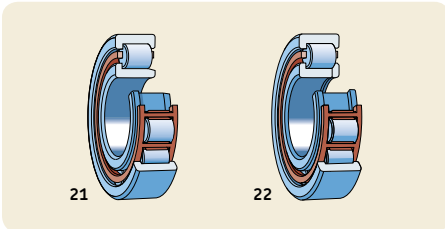

single row
 NJ design (21)
 with an angle ring
 NUP design (22)

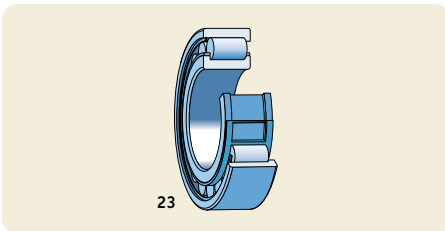

single row
 high-capacity
 NCF design (23)
 NJF design
 NUH design

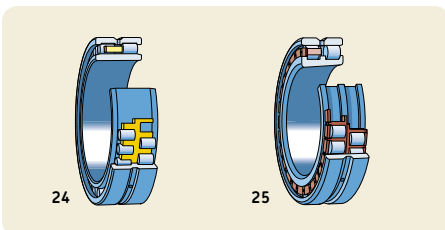

double row¹⁾
 with a cylindrical or tapered bore
 NNU design (24)
 NN design (25)
 NNUP design

¹⁾ Refer to product information available online at skf.com/bearings or separate catalogue.

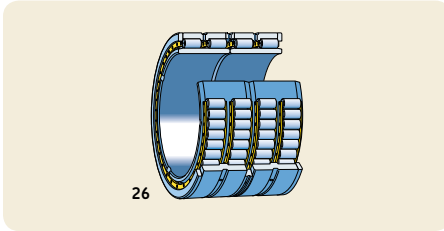

Cylindrical roller bearings (cont.)
four-row¹⁾
with a cylindrical or tapered bore
open design (26)
with contact seals

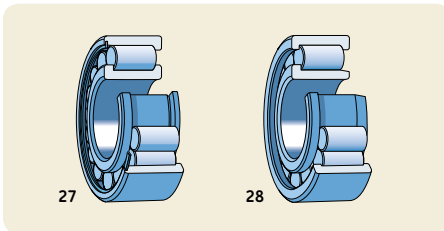

full complement cylindrical roller bearings
single row
NCF design (27)
NJG design (28)

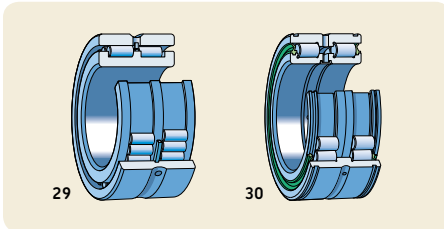

double row
with integral flanges on the inner ring (29)
with integral flanges on the inner and
outer rings
with contact seals (30)

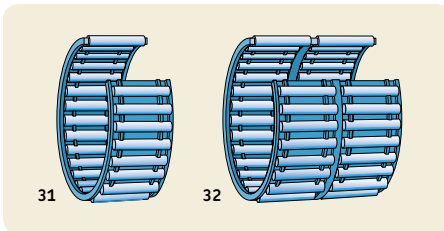

Needle roller bearings (→ page 673)
needle roller and cage assemblies
single row (31)
double row (32)

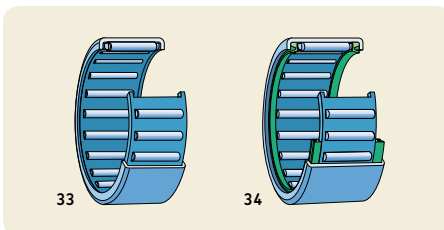

drawn cup needle roller bearings, open ends
single and double row
open basic design (33)
with contact seals (34)

¹⁾ Refer to product information available online at skf.com/bearings or separate catalogue.

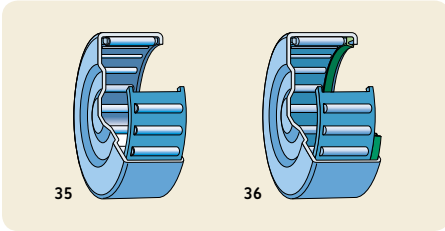

drawn cup needle roller bearings, closed end
single and double row
open basic design (35)
with a contact seal (36)

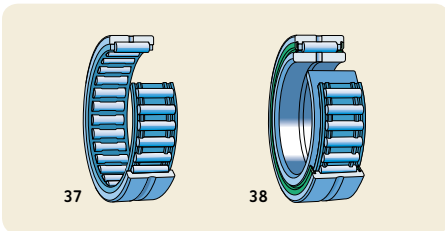

needle roller bearings with flanges
single and double row
without an inner ring (37)
with an inner ring
open basic design
with contact seals (38)

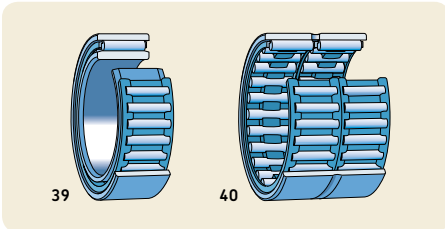

needle roller bearings without flanges
single and double row
with an inner ring (39)
without an inner ring (40)

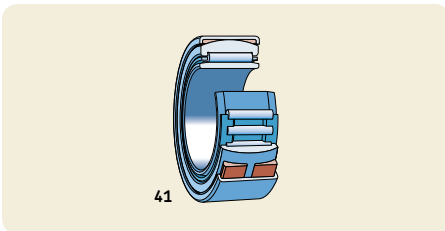

alignment needle roller bearings
without an inner ring
with an inner ring (41)

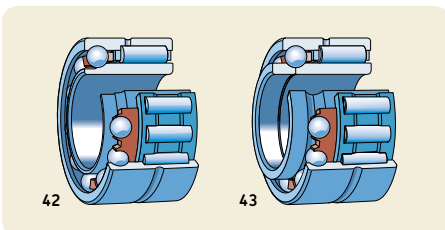

combined needle roller bearings
needle roller / angular contact ball bearings
single direction (42)
double direction (43)

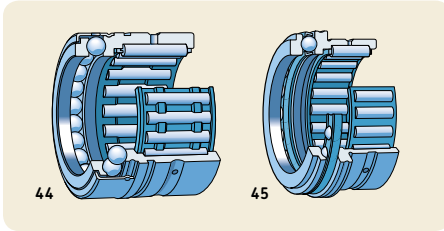

Needle roller bearings (cont.)

needle roller / thrust ball bearings
with a full complement ball set (44)
with a cage-guided ball set
with or without (45) a cover

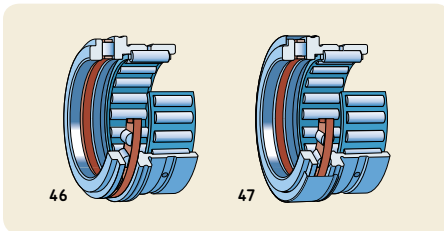

needle roller / cylindrical roller thrust
bearings
without a cover (46)
with a cover (47)

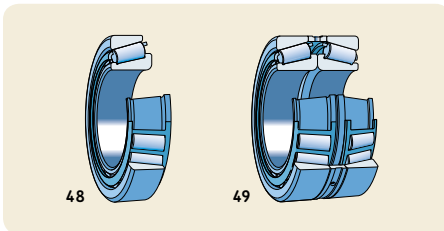

Tapered roller bearings (→ page 797)

single row
single bearings (48)
matched bearings
face-to-face (49)
back-to-back
tandem

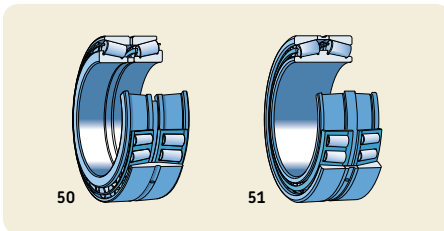

double row¹⁾

TDO configuration (back-to-back) (50)
TDI configuration (face-to-face) (51)

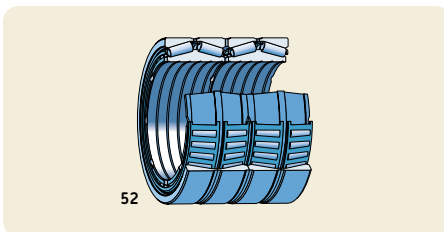

four-row¹⁾

TQO configuration
open design (52)
with contact seals
TQI configuration

¹⁾ Refer to product information available online at skf.com/bearings or separate catalogue.

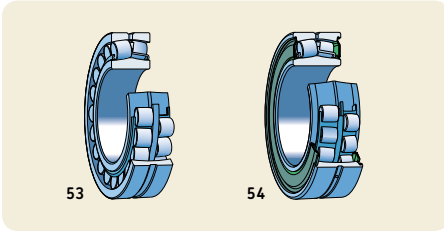

Spherical roller bearings (→ page 879)
 with a cylindrical or tapered bore
 open basic designs (53)
 with contact seals (54)
 for vibratory applications

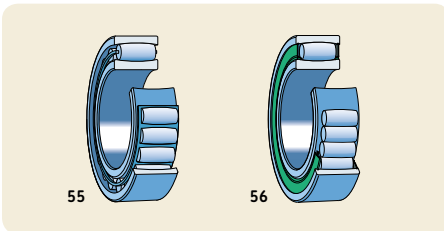

CARB toroidal roller bearings (→ page 957)
 with a cylindrical or tapered bore
 with a cage-guided roller set (55)
 with a full complement roller set
 with contact seals (56)

Thrust bearings

Thrust bearings accommodate loads that are predominantly in the direction of the shaft. The bearings are typically classified by the type of rolling element and shape of the raceways.

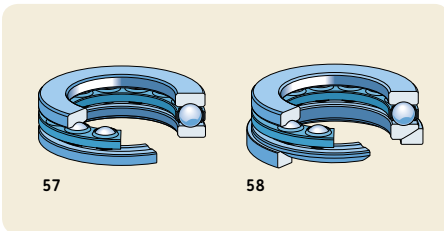

Thrust ball bearings (→ page 1009)
 single direction
 with a flat housing washer (57)
 with a sphered housing washer
 with (58) or without a sphered seat washer

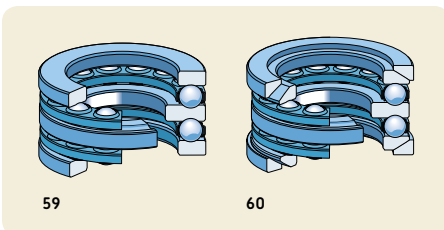

double direction
 with flat housing washers (59)
 with sphered housing washers
 with (60) or without seat washers

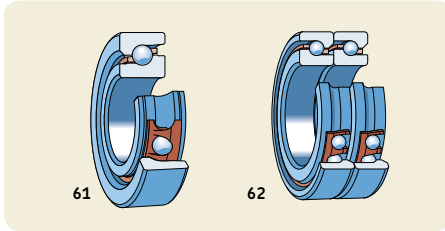

Angular contact thrust ball bearings¹⁾
super-precision bearings
single direction
basic design for single mounting (61)
design for universal matching
matched bearings (62)

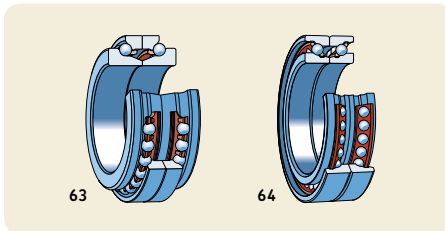

double direction
basic design (63)
high-speed design (64)

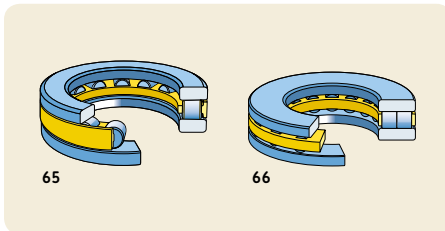

Cylindrical roller thrust bearings (→ page 1037)

single direction
single row (65)
double row (66)
double direction
components
cylindrical roller and cage thrust assemblies
shaft and housing washers

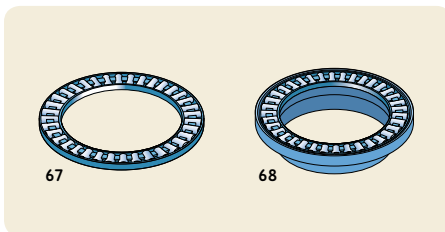

Needle roller thrust bearings (→ page 1057)

single direction
needle roller and cage thrust assemblies (67)
needle roller thrust bearings with a centring
flange (68)
universal washers
thin universal washers
double direction

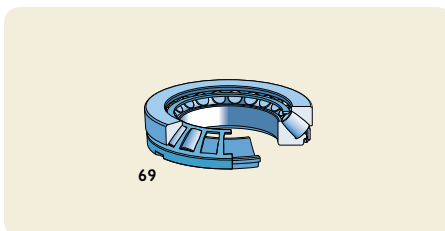

Spherical roller thrust bearings (→ page 1077)

single direction (69)

¹⁾ Refer to product information available online at skf.com/super-precision or separate catalogue.

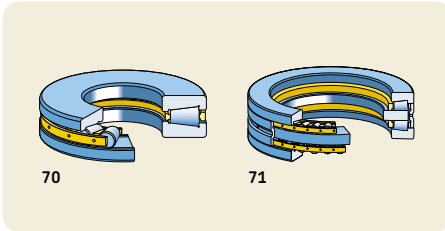

Tapered roller thrust bearings¹⁾
 single direction
 with or without (70) a cover
 screw down bearings
 double direction (71)

Track runner bearings

Track runner bearings (→ page 1099) are bearings with a thick walled outer ring. These ready-to-mount units are used in all types of cam drives, tracks and conveyor systems.

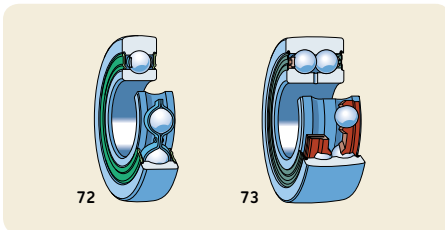

Cam rollers
 single row (72)
 double row (73)

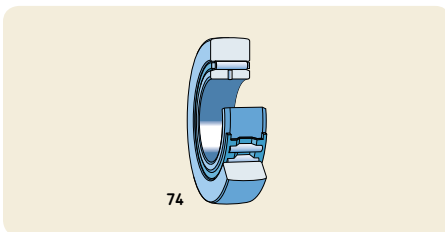

Support rollers
 without flange rings
 with or without contact seals
 without an inner ring
 with an inner ring (74)

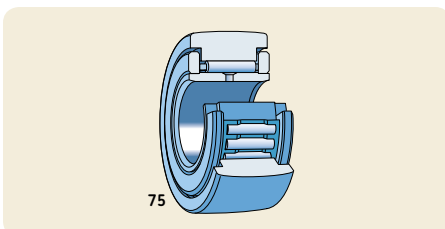

with flange rings, based on needle roller bearings
 with or without contact seals
 with a cage-guided roller set (75)
 with a full complement roller set

¹⁾ Refer to product information available online at skf.com/bearings or separate catalogue.

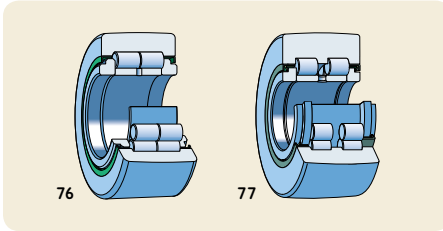

Support rollers (cont.)

with flange rings, based on cylindrical roller bearings
with labyrinth seals (76)
with contact seals (77)
with lamellar seals

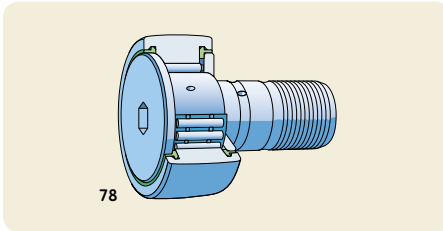

Cam followers

based on needle roller bearings
with or without contact seals
with a concentric seat (78)
with an eccentric seat collar
with a cage-guided roller set (78)
with a full complement roller set

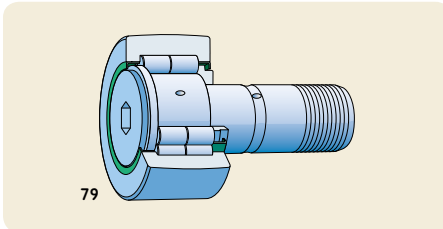

based on cylindrical roller bearings
with labyrinth seals (79)
with contact seals
with a concentric seat (79)
with an eccentric seat collar

Cages

With the exception of full complement bearings, all rolling bearings contain a cage. The number of cages depends on the number of ball or roller sets within the bearing and on the cage design. The primary purposes of a cage are:

- Keeping the rolling elements at a proper distance from each other to reduce the frictional moment and frictional heat in the bearing.
- Keeping the rolling elements evenly spaced to optimize load distribution and enable quiet and uniform operation.
- Guiding the rolling elements in the unloaded zone, to improve the rolling conditions and to prevent damaging sliding movements.
- Retaining the rolling elements of separable bearings when one bearing ring is removed during mounting or dismounting.

Cages are mechanically stressed by frictional, strain and inertial forces. They can also be chemically stressed by certain lubricants, lubricant additives or by-products of their ageing, organic solvents or coolants. Therefore, the design and material of a cage have a significant influence on the suitability of a rolling bearing for a particular application. Therefore, SKF has developed a variety of cages, made of different materials, for the different bearing types.

In each product chapter, information about standard cages and possible alternatives is provided. If a bearing with a non-standard cage is required, check availability prior to ordering.

Cages can be classified according to the manufacturing process and material group into:

- stamped metal cages
- machined metal cages
- polymer cages

Fig. 6

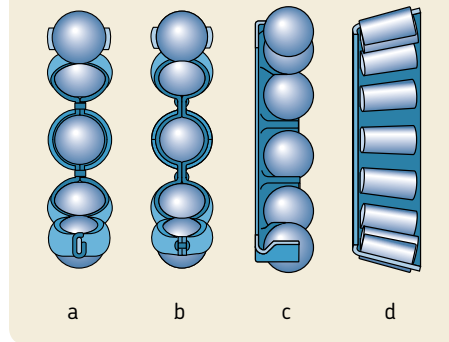

Stamped metal cages

Stamped metal cages for SKF bearings (→ fig. 6) are generally made of sheet steel and with some exceptions, of sheet brass. Depending on the bearing type, the following stamped metal cages are available:

- a ribbon-type cage (a)
- a riveted cage (b)
- a snap-type cage (c)
- a window-type cage (d)

Stamped metal cages are lightweight. They provide ample space inside the bearing to maximize the effects of the lubricant.

Fig. 7

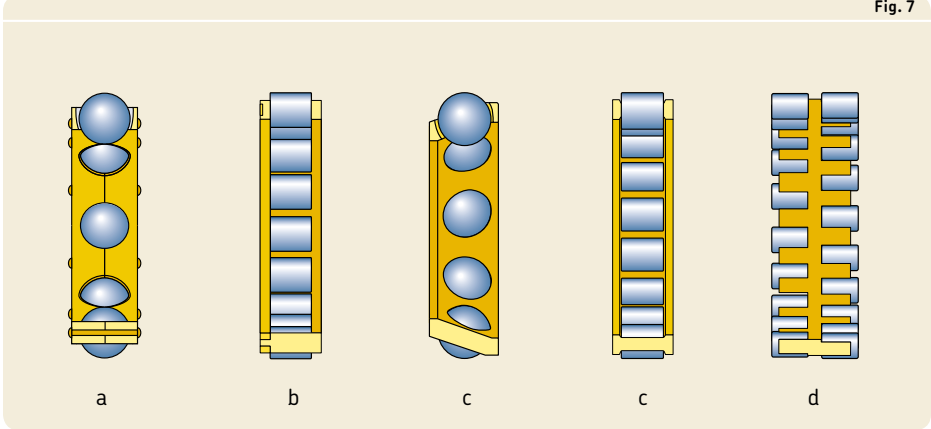

Machined metal cages

Machined metal cages for SKF bearings (→ fig. 7) are made of brass, steel or light alloy. Depending on the bearing type, design and size, the following machined metal cages are available:

- a two-piece machined riveted metal cage (a)
- a two-piece machined metal cage with integral rivets (b)
- a one-piece machined window-type metal cage (c)
- a double prong-type machined metal cage (d)

Machined metal cages, which generally permit higher speeds, are typically used when forces, other than pure rotational forces, are super-imposed on the cage.

Polymer cages

Polymer cages for SKF bearings (→ fig. 8) are injection moulded. SKF also manufactures a fabric reinforced phenolic resin cage, but only for super-precision bearings, which are not included in this catalogue. Depending on the bearing type, design and size, the following polymer cages are available:

- a polymer window-type cage (a)
- a polymer snap-type cage (b)

Polymer cages are characterized by a favourable combination of strength and elasticity. The good sliding properties of the polymer on

Fig. 8

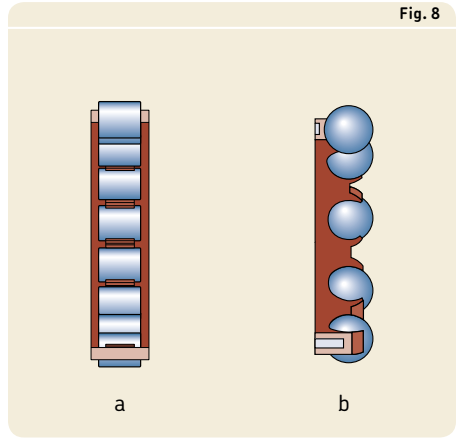

lubricated steel surfaces and the smoothness of the cage surfaces in contact with the rolling elements produce little friction so that frictional heat and wear in the bearing are minimized. The low density of the material means that the inertial forces generated by the cage are minor. The excellent running properties of polymer cages under poor lubrication conditions permit continued operation of the bearing for some time without the risk of seizure and secondary damage.

Cage guidance

Stamped metal cages are typically guided by the rolling elements.

Depending on the bearing type and design, machined metal and polymer cages are radially centred (→ **fig. 9**) either on:

- the rolling elements (a)
- the inner ring (shoulder(s)) (b)
- the outer ring (shoulder(s)) (c)

Cages guided by the rolling elements permit the lubricant to enter the bearing easily.

Ring guided cages, which provide more precise guidance, are typically used when bearing arrangements must accommodate high speeds, frequent, rapid accelerations or high vibration levels. Suitable steps must be taken to provide a sufficient supply of lubricant to the guiding surfaces of the cage. For higher speeds, SKF recommends oil lubrication (→ *Lubrication*, **page 239** and/or relevant product chapter).

Materials

For information about materials used for cages, refer to *Cage materials* (→ **page 152**).

Fig. 9

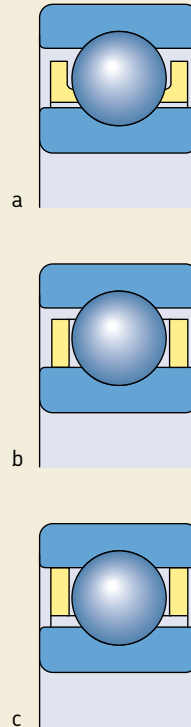

A

Boundary dimensions

Boundary dimensions are the main dimensions of a bearing (→ **fig. 10**). They comprise:

- the bore diameter (d)
- the outside diameter (D)
- the width or height (B , C , T or H)
- the chamfer dimensions (r)

The boundary dimensions for standard metric bearings are contained in the general plans as specified in ISO (International Organization for Standardization) standards:

- ISO 15 for radial rolling bearings, except Y-bearings, some types of needle roller bearings and tapered roller bearings
- ISO 104 for thrust bearings
- ISO 355 for tapered roller bearings

ISO general plans

The ISO general plans for boundary dimensions of radial bearings contain a progressive series of standardized outside diameters for every standard bore diameter arranged in diameter series 7, 8, 9, 0, 1, 2, 3 and 4 (in order of increasing outside diameter). Within each diameter series different width series have also been established (width series 8, 0, 1, 2, 3, 4, 5 and 6 in order of increasing width).

The height series for thrust bearings (height series 7, 9, 1 and 2 in order of increasing height) corresponds to the width series for radial bearings.

Dimension series are formed by combining the number for the width or height series with the number for the diameter series (→ **fig. 11**).

In the ISO general plan for single row metric tapered roller bearings (ISO 355), the boundary dimensions are grouped for certain ranges of the contact angle α , known as the angle series (angle series 2, 3, 4, 5, 6 and 7 in order of increasing angle). Based on the relationship between the bore and outside diameter, and between the total bearing width and the cross-sectional height, diameter and width series have also been established. Here, a dimension series is obtained by combining an angle series with a diameter and a width series (→ **fig. 12**). The dimension series consists of a number for the angle series and two letters. The first letter identifies the diameter series; the second identifies the width series.

With very few exceptions, the bearings in this catalogue comply with the ISO general

Fig. 10

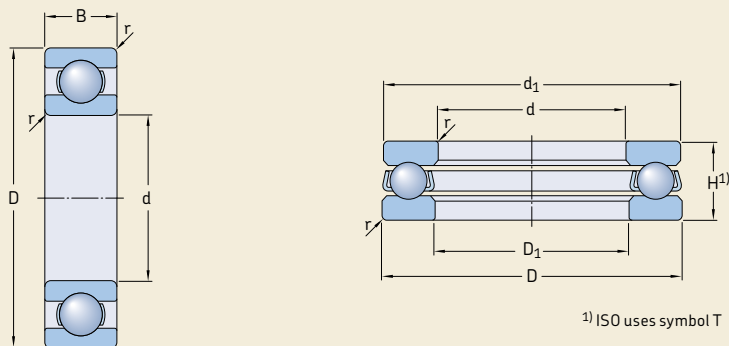

plans. Experience has shown that the requirements of the vast majority of bearing applications can be met using bearings with these standardized dimensions. Following ISO standards for the boundary dimensions is a prerequisite for interchangeability of bearings. Specific information about compliance to dimension standards is provided in each product chapter.

General plans for inch bearings

A large group of bearings with inch dimensions are inch tapered roller bearings. The dimensions of these bearings are in accordance with AFBMA Standard 19 (ANSI B3.19). ANSI/ABMA Standard 19.2 has replaced this standard, but does not include dimensions.

In addition to the inch tapered roller bearings, some inch ball bearings and cylindrical roller bearings are also available, but not listed in this catalogue.

A

Fig. 11

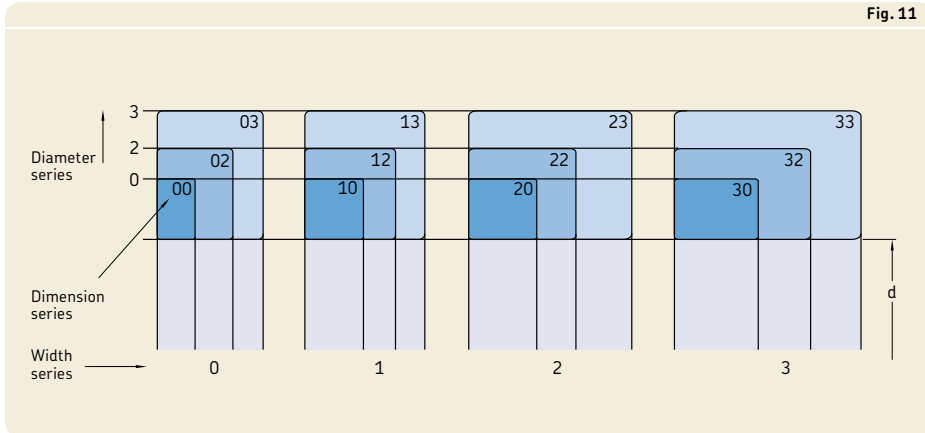
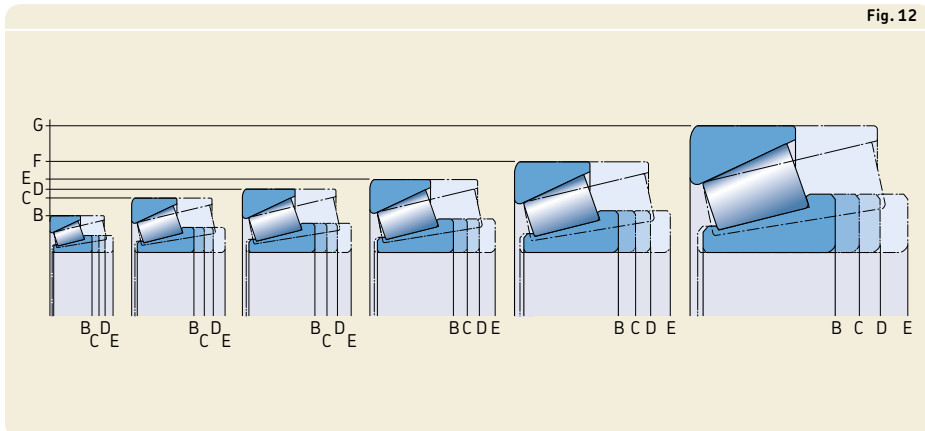

Fig. 12



Basic bearing designation system

The designations of most SKF rolling bearings follow a designation system. The complete bearing designation may consist of a basic designation with or without one or more supplementary designations (→ **diagram 1**). The complete designation is always marked on the bearing package, whereas the marking on the bearing may be incomplete or deviate from the designation.

The basic designation identifies:

- the bearing type
- the basic design
- the boundary dimensions

Prefixes and suffixes identify bearing components or variants having a design and/or feature(s) that differ in some respect from the basic design.

Basic designations

A basic designation typically contains three to five digits. Some products, like cylindrical roller bearings, can have a combination of alphanumeric characters. The basic designation system is shown in **diagram 2**. The number and letter combinations have the following meaning:

- The first digit or letter or combination of letters identifies the bearing type and eventually a basic variant.
- The following two digits identify the ISO dimension series. The first digit indicates the width or height series (dimensions B, T or H). The second digit identifies the diameter series (dimension D).
- The last two digits of the basic designation identify the size code of the bearing bore. The size code multiplied by 5 gives the bore diameter (d) in mm.

The most important exceptions in the basic bearing designation system are:

- 1 In a few cases the digit for the bearing type or the first digit of the dimension series identification is omitted. These digits are shown in brackets in **diagram 2**.

Diagram 1

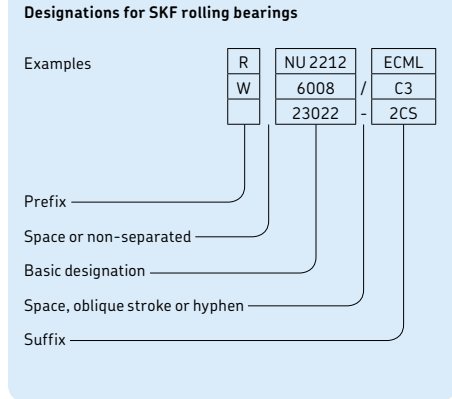

- 2 Bearings with a bore diameter of 10, 12, 15 or 17 mm have the following size code identifications:

00 = 10 mm
 01 = 12 mm
 02 = 15 mm
 03 = 17 mm

- 3 For bearings with a bore diameter < 10 mm, or ≥ 500 mm, the bore diameter is generally given in millimetres (uncoded). The size identification is separated from the rest of the bearing designation by an oblique stroke, e.g. 618/8 (d = 8 mm) or 511/530 (d = 530 mm). This is also true of standard bearings in accordance with ISO 15 that have a bore diameter of 22, 28 or 32 mm, e.g. 62/22 (d = 22 mm).
- 4 For some bearings with a bore diameter < 10 mm, such as deep groove, self-aligning and angular contact ball bearings, the bore diameter is also given in millimetres (uncoded) but is not separated from the series designation by an oblique stroke, e.g. 629 or 129 (d = 9 mm).
- 5 Bore diameters that deviate from the standard bore diameter of a bearing are uncoded and given in millimetres up to three decimal places. This bore diameter identification is part of the basic designation and is separated from the basic designation by an oblique stroke, e.g. 6202/15.875 (d = 15,875 mm = 5/8 in).

Diagram 2



Basic designation system for SKF standard metric ball and roller bearings

Bearing series														
				6(0)4										
				544	623					(0)4				
				524	6(0)3					33				
				543	622					23				
				523	6(0)2					(0)3				
				542	630			23		22				
				522	6(1)0			32		22				
				522	6(1)0			22		12				
				231	16(0)0			41		(0)2				
				240	323			31		31		41		
				230	313			60		30		31		
				249	303			50		20		60		
				139	239	332	513	638	7(0)4	814	40	10	50	
				130	248	322	532	628	7(0)3	894	30	39	40	23
				(1)23	238	302	512	618	7(0)2	874	69	29	30	(0)3
				1(0)3	331	511	608	7(1)0	813	59	19	69	12	
				(1)22	294	330	510	637	719	893	49	38	49	(0)2
(0)33	1(0)2	293	320	4(2)3	591	627	718	812	39	28	39	10		
(0)32	1(1)0	292	329	4(2)2	590	617	708	811	29	18	48	19		

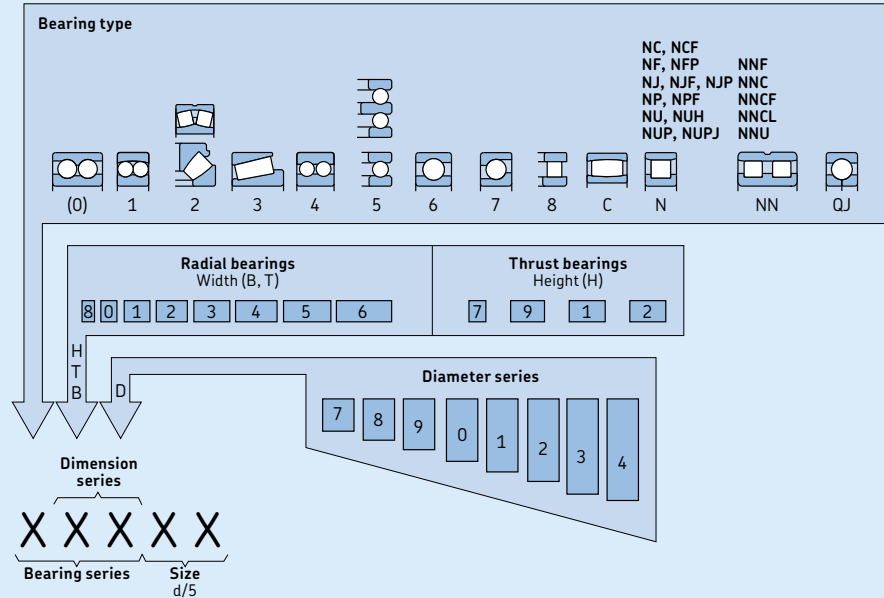

Code	Bearing type	Code	Bearing type	Code	Bearing type
0	Double row angular contact ball bearing	7	Single row angular contact ball bearing	QJ	Four-point contact ball bearing
1	Self-aligning ball bearing	8	Cylindrical roller thrust bearing	T	Tapered roller bearing in accordance with ISO 355
2	Spherical roller bearing, spherical roller thrust bearing	C	CARB toroidal roller bearing		
3	Tapered roller bearing	N	Cylindrical roller bearing. Two or more letters are used to identify the number of the rows or the configuration of the flanges, e.g. NJ, NU, NUP, NN, NNU, NNCF etc.		
4	Double row deep groove ball bearing				
5	Thrust ball bearing				
6	Single row deep groove ball bearing				

Designation system for suffixes

Designation example

	Group 1	Group 2	Group 3	/	Group 4					
					4.1	4.2	4.3	4.4	4.5	4.6
6205-RS1NRTN9/P63LT20CVB123	6205	-RS1NR	TN9	/		P63			LT20C	VB123
23064 CCK/HA3C084S2W33	23064	CC	K	/	HA3	C084		S2	W33	

Basic designation —

Space —

Suffixes

Group 1: Internal design —

Group 2: External design (seals, snap ring groove, etc.) —

Group 3: Cage design —

Oblique stroke —

Group 4: Variants

Group 4.1: Materials, heat treatment —

Group 4.2: Accuracy, clearance, quiet running —

Group 4.3: Bearing sets, matched bearings —

Group 4.4: Stabilization —

Group 4.5: Lubrication —

Group 4.6: Other variants —

Series designations

Each standard bearing belongs to a given bearing series, which is identified by the basic designation without the size identification. Series designations often include a suffix A, B, C, D or E or a combination of these letters. These letters are used to identify differences in internal design.

The most common series designations are shown in **diagram 2** (→ **page 43**) above the illustrations. The digits in brackets are omitted in the series designation.

Prefixes and suffixes

Prefixes and suffixes provide additional information about the bearing. Prefixes and suffixes and their significance are explained in the relevant product chapter.

Prefixes

Prefixes are mainly used to identify components of a bearing. They can also identify bearing variants.

Suffixes

Suffixes identify designs or variants, which differ in some way from the original design or from the current basic design. The suffixes are divided into groups. When more than one special feature is to be identified, suffixes are provided in the order shown in **diagram 3**.

Bearing designations not covered by the basic bearing designation system

Y-bearings (insert bearings)

The designations for Y-bearings differ somewhat from the system described above and are covered in the relevant product chapter.

Needle roller bearings

The designations for needle roller bearings do not fully follow the system described above and are covered in the relevant product chapter.

Tapered roller bearings

The designations for metric tapered roller bearings follow either the system described above or a designation system established by ISO in 1977 (→ ISO 355). Inch tapered roller bearings are designated in accordance with the relevant ANSI/ABMA standard.

The designation system for tapered roller bearings is explained in the relevant product chapter.

Customized bearings

Bearings designed to meet a specific customer requirement are typically designated by a drawing number. The drawing number does not provide any information about the bearing.

Other rolling bearings

Rolling bearings not covered in this catalogue, such as super-precision bearings, thin section bearings, slewing bearings or linear bearings follow designation systems, which can differ significantly from the system described above. Information about these designation systems is provided in the relevant catalogues.

Basic selection criteria

Each bearing type displays characteristic properties, based on its design, which makes it more, or less, appropriate for a given application. For example, deep groove ball bearings can accommodate radial loads and axial loads. These bearings, which are also available in the SKF Energy Efficient performance class, can be manufactured with a high degree of running accuracy and are available in quiet running variants. Therefore, they are preferred for small and medium-size electric motors.

Spherical and toroidal roller bearings can accommodate very heavy loads and are self-aligning. These properties make them popular for applications, where there are heavy loads, shaft deflections and misalignment.

In many cases, however, several factors have to be considered and weighed against each other when selecting a bearing, so that no general rules can be given. The information provided here should serve to indicate the most important factors to be considered when selecting a standard bearing:

- available space
- loads
- misalignment
- precision
- speed
- friction
- quiet running
- stiffness
- axial displacement
- mounting and dismounting
- sealing solutions

The total cost of a bearing system and inventory considerations can also influence bearing selection.

Some of the most important criteria to consider, when designing a bearing arrangement, are covered in depth in separate sections of this catalogue. These include load carrying capacity and life, friction, permissible speeds, bearing internal clearance or preload, lubrication and sealing solutions.

Detailed information on the individual bearing types, including their characteristics and the available designs, is provided in each product chapter.

Fig. 13

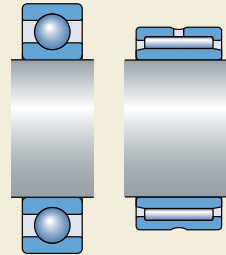

Fig. 14

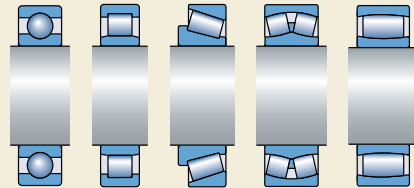
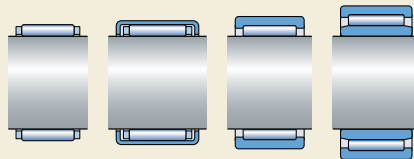

Fig. 15



This catalogue does not cover the complete SKF rolling bearings assortment. Specific catalogues and brochures are available for bearings not covered here. For additional information, contact SKF.

Available space

In many cases, the principal dimensions of a bearing are predetermined by the machine's design. For example, the shaft diameter determines the bearing bore diameter.

For small-diameter shafts all types of ball bearings can be used, the most popular being deep groove ball bearings; needle roller bearings are also suitable (→ **fig. 13**). For large-diameter shafts, cylindrical, tapered, spherical and toroidal roller bearings and deep groove ball bearings are available (→ **fig. 14**).

When radial space is limited, bearings with a low cross-sectional height, should be chosen. These can include needle roller and cage assemblies, drawn cup needle roller bearings and needle roller bearings with or without an inner ring (→ **fig. 15**). Other bearing types in the 8 or 9 diameter series can also be used.

When axial space is limited, narrow series cylindrical roller bearings and deep groove ball bearings can be used to accommodate radial or combined loads (→ **fig. 16**). Combined needle roller bearings (→ **fig. 17**) can also be used. For purely axial loads, needle roller and cage thrust assemblies (with or without washers) as well as thrust ball bearings and cylindrical roller thrust bearings can be used (→ **fig. 18**).

Fig. 16

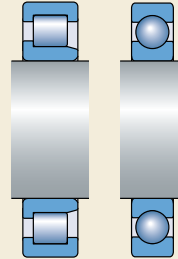

Fig. 17

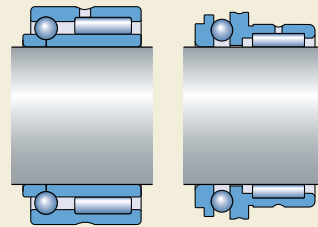
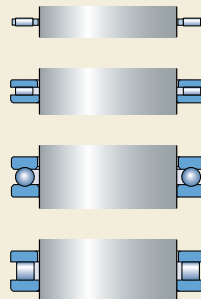

Fig. 18



Bearing basics

Loads

Magnitude of load

The magnitude of the load is one of the factors that usually determines the size of the bearing. Generally, roller bearings are able to support heavier loads than similar-sized ball bearings (→ **fig. 19**). Bearings with a full complement of rolling elements can accommodate heavier loads than corresponding bearings with a cage. Ball bearings are typically used in applications where loads are light to normal. Roller bearings are used in applications where loads are heavier.

Direction of load

Radial loads

NU and N design cylindrical roller bearings, needle roller bearings and toroidal roller bearings can only support pure radial loads (→ **fig. 20**). All other radial bearings can accommodate some axial loads in addition to radial loads (→ *Combined loads*, **page 50**).

Axial loads

Thrust ball bearings and four-point contact ball bearings (→ **fig. 21**) are suitable for light or normal loads that are purely axial. Single direction thrust ball bearings can only accommodate axial loads in one direction. For axial loads acting in both directions, double direction thrust ball bearings are needed.

Fig. 19

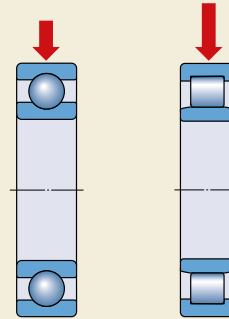

Fig. 20

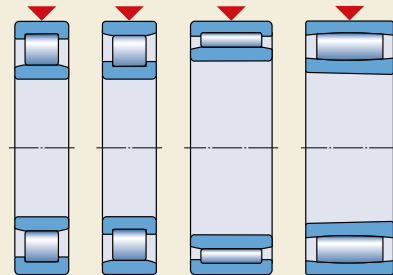
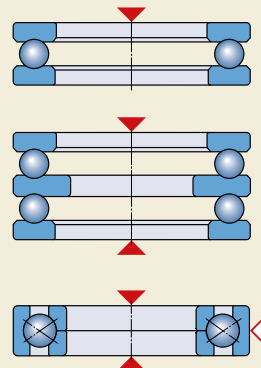

Fig. 21



Angular contact thrust ball bearings can support normal axial loads at high speeds. Here, the single direction bearings can also accommodate simultaneously acting radial loads, while double direction bearings are normally used only for purely axial loads (→ **fig. 22**).

For normal to heavy loads that are purely axial and act in one direction only, needle roller thrust bearings, cylindrical and tapered roller thrust bearings are suitable. Spherical roller thrust bearings (→ **fig. 23**) can accommodate axial loads in one direction only as well as radial loads. For heavy alternating axial loads, two cylindrical roller thrust bearings or two spherical roller thrust bearings can be mounted in pairs.

Fig. 22

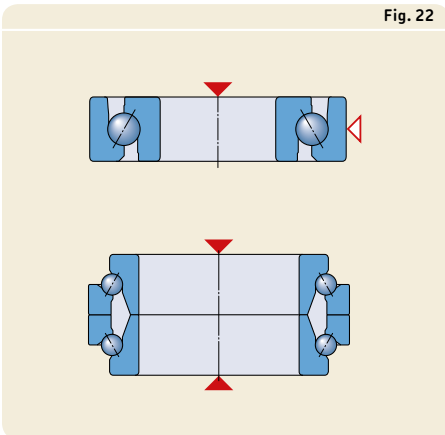
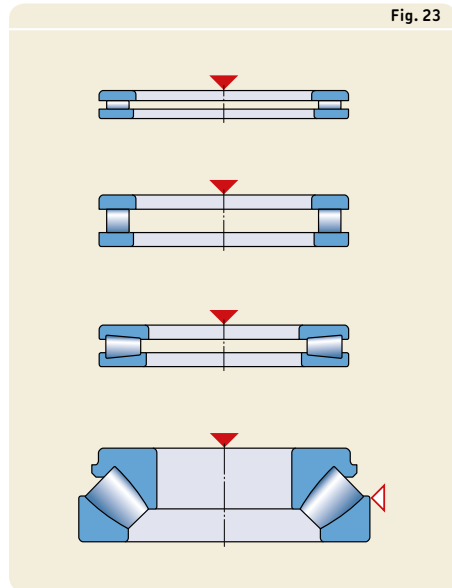

Fig. 23



Bearing basics

Combined loads

A combined load consists of a radial and axial load acting simultaneously. The ability of a bearing to accommodate an axial load is determined by the contact angle α . The greater the angle, the higher the axial load carrying capacity of the bearing. An indication of this is given by the calculation factor Y , which becomes smaller as the contact angle α increases. The values of the angle α or the factor Y are listed in the relevant product chapter.

The axial load carrying capacity of a deep groove ball bearing depends on its internal design and the operational internal clearance (→ *Deep groove ball bearings*, **page 295**).

For combined loads, single and double row angular contact ball bearings and single row tapered roller bearings are most commonly used, although deep groove ball bearings and spherical roller bearings are suitable (→ **fig. 24**). In addition, self-aligning ball bearings and NJ and NUP design cylindrical roller bearings as well as NJ and NU design cylindrical roller bearings with HJ angle rings can be used for combined loads when the axial component is relatively small (→ **fig. 25**).

Single row angular contact ball bearings, single row tapered roller bearings, NJ design cylindrical roller bearings, NU design cylindrical roller bearings with an HJ angle ring and spherical roller thrust bearings can accommodate axial loads in one direction only. For axial loads that alternate direction, these bearings must be combined with a second bearing. For this reason, universally matchable angular contact ball bearings and matched sets of tapered roller bearings are available (→ *Bearings for universal matching*, **page 477**, or *Matched bearings*, **page 802**).

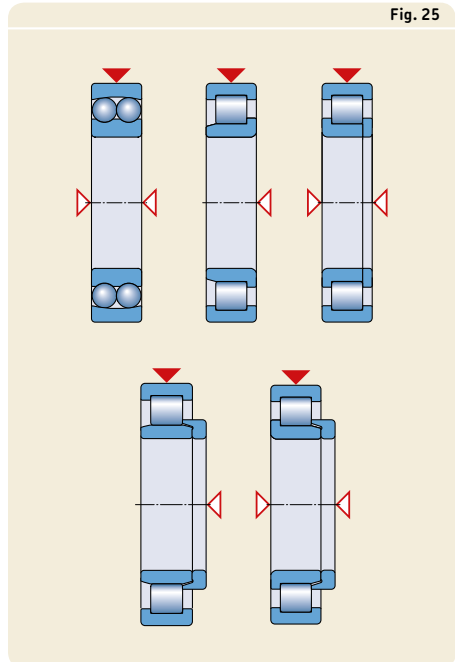
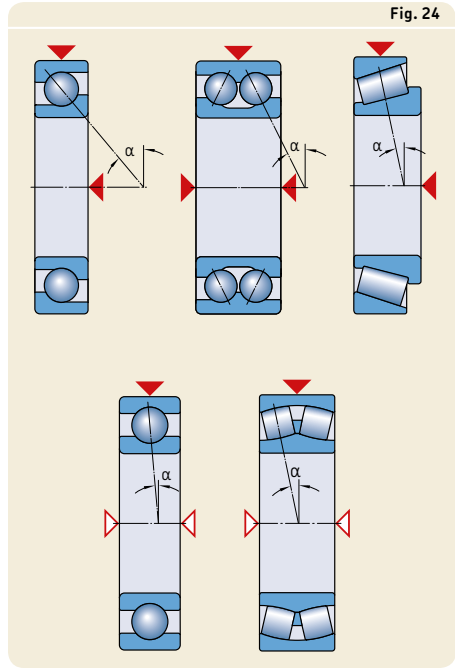

When the axial component of the combined load is significantly large, a second bearing, free of radial load may be necessary. In addition to thrust bearings, some radial bearings, e.g. deep groove ball bearings or four-point contact ball bearings (→ **fig. 26**) are suitable. To make sure that the bearing is subjected to a purely axial load, the bearing outer ring must be mounted with radial clearance.

Moment loads

When a load acts eccentrically on a bearing, a tilting moment occurs. Double row bearings, e.g. deep groove and angular contact ball bearings, can accommodate tilting moments, but paired single row angular contact ball bearings and tapered roller bearings arranged back-to-back, are more suitable (→ **fig. 27**).

Fig. 26

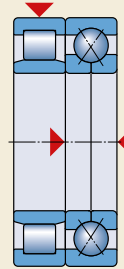

A

Fig. 27

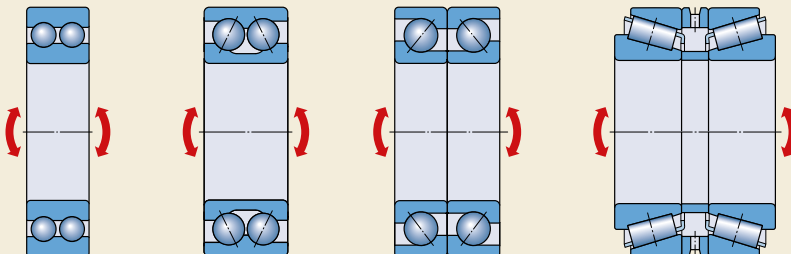

Misalignment

Angular misalignment between the shaft and housing occurs when the shaft deflects (bends) under the operating load. Misalignment can also occur when the bearings are too far apart.

Rigid bearings, i.e. deep groove ball bearings and cylindrical roller bearings can accommodate only a few minutes of angular misalignment without damaging the bearing. Self-aligning bearings, e.g. self-aligning ball bearings, spherical roller bearings, toroidal roller bearings and spherical roller thrust bearings (→ **fig. 28**), can accommodate shaft deflections as well as initial misalignment resulting from machining or mounting errors. Values for the permissible misalignment are

listed in the relevant product chapter. If the expected misalignment exceeds the permissible values, contact the SKF application engineering service.

Thrust ball bearings with sphered housing and seat washers, Y-bearing units and alignment needle roller bearings (→ **fig. 29**) can compensate for initial misalignment arising from machining or mounting errors.

Fig. 28

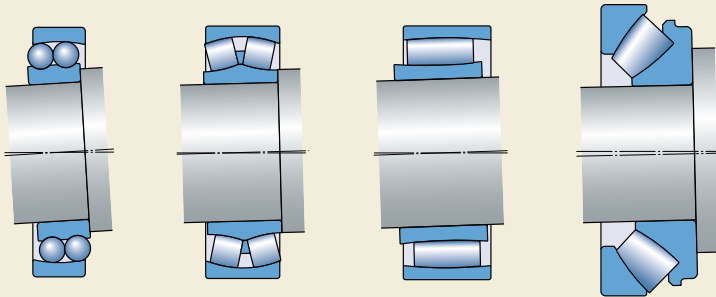
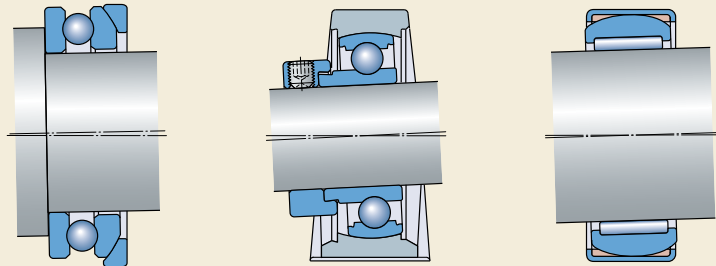

Fig. 29



Precision

When dealing with rolling bearings, precision is described by tolerance classes for running accuracy and dimensional accuracy.

Each product chapter provides information about the tolerance classes to which the bearings are manufactured. SKF manufactures a comprehensive assortment of super-precision bearings, including single row angular contact ball bearings, single and double row cylindrical roller bearings and single and double direction angular contact thrust ball bearings. For information about super-precision bearings, refer to the product information available online at skf.com/super-precision.

Speed

The permissible operating temperature puts limits on the speed at which rolling bearings can be operated. Bearing types that operate with low friction and generate low frictional heat are therefore the most suitable for high-speed operation.

The highest speeds can be achieved with deep groove ball bearings and self-aligning ball bearings (→ **fig. 30**) when loads are purely radial. Angular contact ball bearings (→ **fig. 31**) are typically used when there are combined loads. This is particularly true for super-precision angular contact ball bearings and deep groove ball bearings with ceramic rolling elements, also referred to as hybrid bearings.

Because of their design, thrust bearings cannot accommodate speeds as high as radial bearings.

Fig. 30

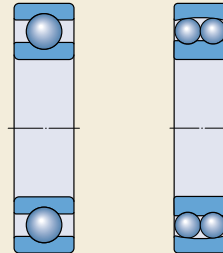

Fig. 31



A

Friction

Rolling bearings are also known as “anti-friction bearings”, but of course, some frictional losses occur in the bearing. One contributing factor to rolling friction in a bearing is the result of elastic deformation of the rolling elements and raceways under load. Other sources include, but are not limited to, the sliding friction that occurs between the rolling elements and cage, flanges and guide rings, and between seals and their counterface. Friction in the lubricant also contributes to the total frictional moment. The frictional moment of SKF rolling bearings can be calculated (→ *Friction*, page 97).

In general, ball bearings have a lower frictional moment than roller bearings. If very low friction is an essential requirement, SKF Energy Efficient (E2) bearings should be considered. The frictional moment in SKF E2 bearings is at least 30% lower than a similar-sized SKF standard bearing. SKF E2 bearings are available for several bearing types:

- single row deep groove ball bearings
- Y-bearings (insert bearings)
- double row angular contact ball bearings
- single row tapered roller bearings
- spherical roller bearings
- cylindrical roller bearings

Quiet running

In certain applications, e.g. small electric motors for household appliances or office machinery, the noise level in operation is an important factor and can influence the choice of bearing type. SKF manufactures a deep groove ball bearing variant specifically for these types of applications.

Stiffness

The stiffness of a rolling bearing is characterized by the magnitude of the elastic deformation (resilience) in the bearing under load. Generally, this deformation is very small and can be neglected. However, in applications like machine tool spindles and transmission differentials, stiffness is a key operational parameter.

Because of the contact conditions between the rolling elements and raceways, roller bearings, e.g. cylindrical or tapered roller bearings (→ **fig. 32**), have a higher degree of stiffness than ball bearings. Bearing stiffness can be further enhanced by applying a preload (→ *Bearing preload*, page 214).

Fig. 32

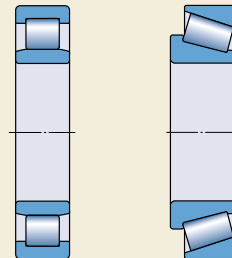

Axial displacement

Shafts, or other rotating machine components, are generally supported by a locating and a non-locating bearing (→ *Bearing systems, page 160*).

The bearing in the locating position must be able to locate the shaft axially in both directions. The most suitable bearings for the locating position are those bearings that can accommodate combined loads, or can provide axial guidance in combination with a second bearing.

Non-locating bearings must accommodate axial movement of the shaft, to avoid induced axial loads when, for example, thermal elongation of the shaft occurs. Bearings suitable for the non-locating position include needle roller bearings and NU and N design cylindrical roller bearings (→ **fig. 33**). NJ design cylindrical roller bearings and some full complement design cylindrical roller bearings can also be used.

In applications where the required axial displacement is relatively large and misalignment may also occur, a CARB toroidal roller bearing is an excellent choice as the non-locating bearing (→ **fig. 34**).

All of these bearings accommodate axial displacement between the shaft and the housing, within the bearing. Values for the permissible axial displacement within the bearing are listed in the relevant product tables.

If non-separable bearings, e.g. deep groove ball bearings or spherical roller bearings (→ **fig. 35**) are used as non-locating bearings, one of the bearing rings must have a loose fit (→ *Radial location of bearings, page 165*).

Fig. 33

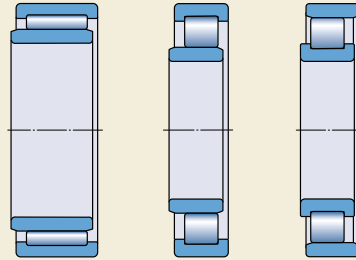

Fig. 34

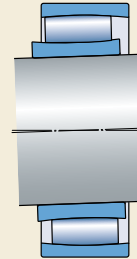
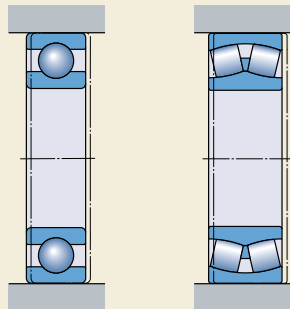

Fig. 35



Mounting and dismounting

Cylindrical bore

Bearings with a cylindrical bore are easier to mount and dismount if they are separable, particularly if interference fits are required for both rings. Separable bearings are also preferable if frequent mounting and dismounting are required, because the ring with the rolling element and cage assembly of these separable bearings can be fitted independently of the other ring, e.g. four-point contact ball bearings, cylindrical, needle and tapered roller bearings (→ **fig. 36**), as well as ball and roller thrust bearings.

Tapered bore

Bearings with a tapered bore (→ **fig. 37**) can be mounted easily on a tapered shaft seat or on a cylindrical shaft seat using an adapter or withdrawal sleeve (→ **fig. 38**).

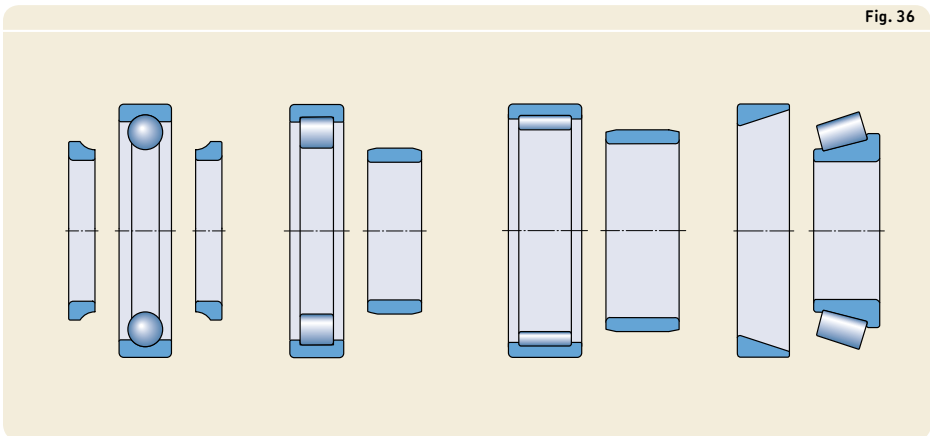

Fig. 36

Fig. 37

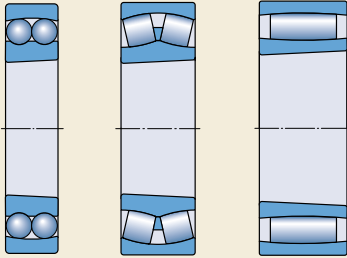
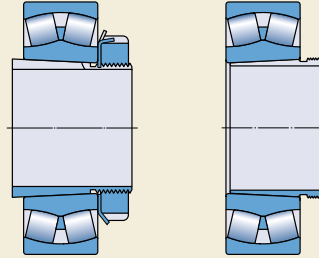

Fig. 38



A

Bearing basics

Sealing solutions

To keep lubricant in and contaminants out of the bearing, SKF supplies bearings capped with integral seals or shields:

- shields (→ **fig. 39**)
- non-contact seals (→ **fig. 40**)
- low-friction seals (→ **fig. 41**)
- contact seals (→ **fig. 42**)

These bearings can provide cost-effective and space-saving solutions for many applications. Capped bearings are available for different bearing types:

- deep groove ball bearings
- angular contact ball bearings
- self-aligning ball bearings
- cylindrical roller bearings
- needle roller bearings
- spherical roller bearings
- CARB toroidal roller bearings
- track runner bearings
- Y-bearings (insert bearings)

Bearings capped on both sides are typically lubricated for the life of the bearing and should not be washed or relubricated. They are filled with the appropriate amount of high-quality grease under clean conditions.

Fig. 39

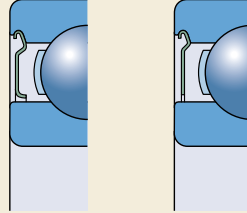

Fig. 40

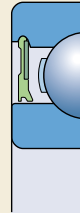

Fig. 41

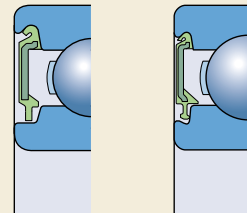
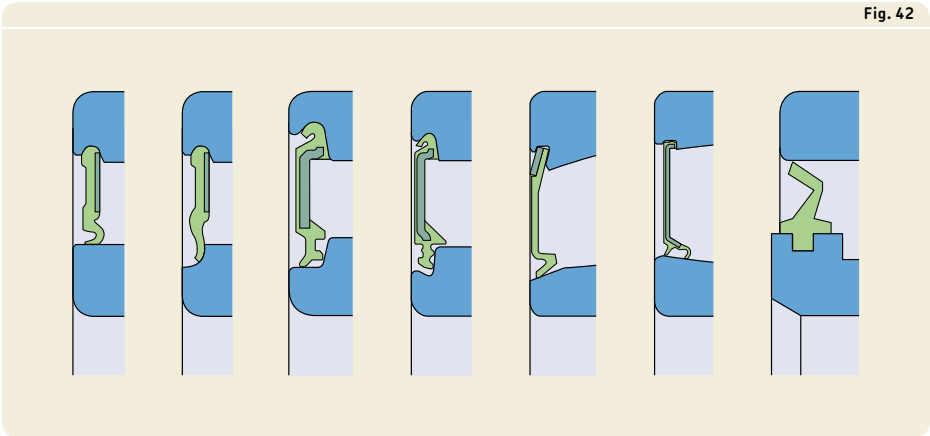
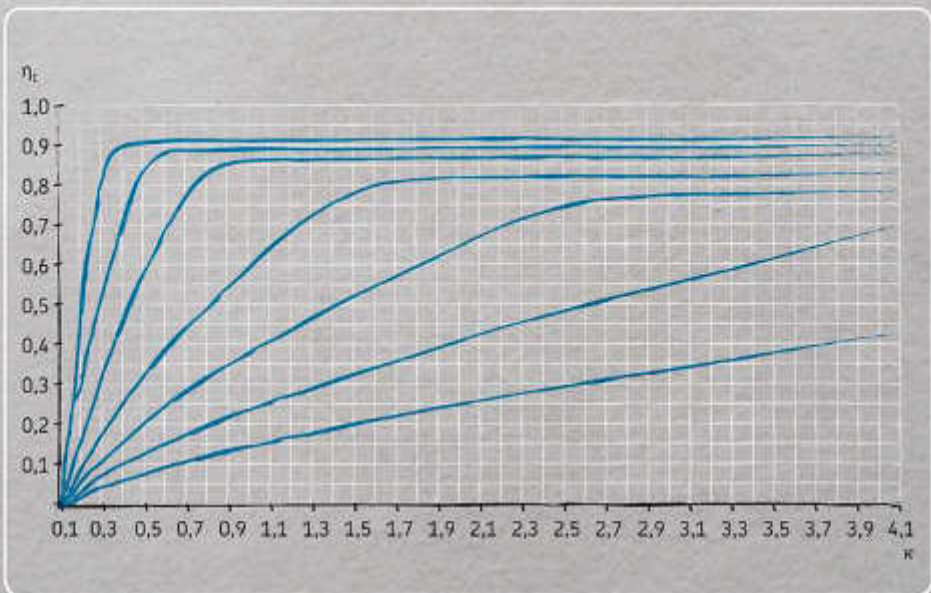

Fig. 42



A



Selecting bearing size

A systems approach to bearing selection	62	SKF calculation tools	92
Bearing system life	62	Calculation tools available online at skf.com/bearingcalculator	92
Bearing life and load ratings	63	SKF Bearing Beacon	93
Bearing life definition	63	Orpheus	93
Load ratings	63	Beast	93
Dynamic load ratings	63	Other programs	93
Static load ratings	64	SKF Engineering Consultancy Services	94
Selecting bearing size using the life equations	64	Advanced computer programs	94
Basic rating life	64	SKF life testing	95
SKF rating life	64		
SKF life modification factor a_{SKF}	65		
Lubrication conditions – the viscosity ratio κ	71		
Considering EP additives	73		
Factor η_c for contamination level	74		
Calculating life with variable operating conditions	81		
Influence of the operating temperature	82		
Requisite rating life	82		
Dynamic bearing loads	84		
Calculating dynamic bearing loads	84		
Equivalent dynamic bearing load	85		
Requisite minimum load	86		
Selecting bearing size using static load carrying capacity	87		
Equivalent static bearing load	88		
Required basic static load rating	88		
Checking the static load carrying capacity	89		
Calculation examples	90		

A systems approach to bearing selection

In the SKF life rating equation, the stresses resulting from external loads are considered together with the tribological stresses in the rolling contact area. Understanding the influence of these combined stress systems on bearing life enables a more accurate prediction of how a bearing will perform in its application.

Due to its complexity, a detailed description of the theory is beyond the scope of this catalogue. Therefore, a simplified approach is presented under *SKF rating life* (→ page 64). This enables users to fully exploit bearing life potential, to undertake controlled downsizing, and to recognize the influence of lubrication and contamination on bearing service life.

Bearing system life

Metal fatigue of the rolling contact surfaces is a well-known failure mode for rolling bearings. Metal fatigue can be the result of a variety of factors including but not limited to excessive frictional heat, poor or contaminated lubrication conditions, and heavy external and/or indeterminate loads.

Therefore, a criterion based on raceway fatigue is generally sufficient for the selection and sizing of a rolling bearing for a given application. International standards such as ISO 281 are based on metal fatigue of the rolling contact surfaces. Nevertheless, it is import-

ant to remember that the complete bearing can be viewed as a system in which the life of each component, i.e. rolling elements, raceways, cage, lubricant and seals, when present, contributes equally and in some cases dictates the effective endurance of the bearing (→ fig. 1).

In the different sections of this catalogue, references are made to relevant aspects of the strength and suitability of other components of the bearing viewed as a system that need to be checked to ensure the best performance.

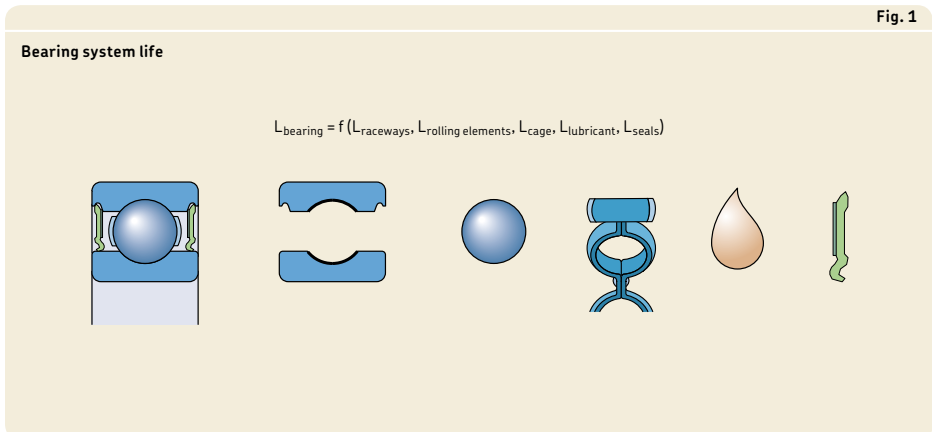

Bearing life and load ratings

Bearing life definition

The individual life of a rolling bearing is expressed as the number of revolutions or the number of operating hours at a given speed that the bearing is capable of enduring before the first sign of metal fatigue (spalling) occurs on a raceway of the inner or outer ring or a rolling element. However, under controlled laboratory conditions, seemingly identical bearings operating under identical conditions have different individual endurance lives. A clearer definition of the term “bearing life” is therefore essential to calculate bearing size. All information presented by SKF with regard to load ratings is based on the life that 90% of a sufficiently large group of apparently identical bearings can be expected to attain or exceed.

The rated life based on the above definition has to satisfy the requisite life expectations of the bearing application. In the absence of previous experience, guidelines regarding specification life of different bearing applications are provided in **tables 9 and 10 (→ page 83)**.

Due to the statistical nature of bearing life, it must be pointed out that the observed time to failure of an individual bearing installed in an application can be related to its rated life only if the failure probability, of that particular bearing, can be determined in relation to the general population of bearings running under similar conditions. For instance, if a bearing failure is observed in a bearing fan application counting a total of two hundred installed bearings working under similar conditions, this represent a failure probability of just 0,5%, thus a reliability for the installed application of 99,5%.

Several investigations performed throughout the years regarding the failures of bearings used in a variety of applications have shown that in a very large population (several million bearings), the observed failures are a relatively rare event and not directly related to typical raceway spalling. This shows that the design guidelines based on 90% reliability and the use of static and dynamic safety factors can lead to robust bearing solutions in which typical fatigue failures are in general avoided. Indeed, observed field failures are mostly related to abrasive wear, moisture, corrosion, improper installation, improper shaft/housing

fits, skidding of rolling elements, unforeseen contamination or related to failure of the cage, of the sealing or of the lubrication system.

Load ratings

A bearing is typically selected on the basis of its load rating relative to the applied loads and the requirements regarding bearing life and reliability. Values for the basic dynamic load rating C and the basic static load rating C_0 are listed in the product tables.

Both dynamic and static bearing load conditions should be independently verified and should include any heavy, short duration shock loads that may occur on rare occasions.

Dynamic load ratings

The basic dynamic load rating C is used for life calculations involving dynamically stressed bearings, i.e. bearings that rotate under load. It expresses the bearing load that will result in an ISO 281 basic rating life of 1 000 000 revolutions. It is assumed that the load is constant in magnitude and direction and is radial for radial bearings and axial, centrally acting, for thrust bearings.

The basic dynamic load ratings for SKF bearings are determined in accordance with the procedures outlined in ISO 281. The load ratings provided in this catalogue apply to chromium steel bearings, heat-treated to a minimum hardness of 58 HRC, and operating under normal conditions. An exception to this are polymer bearings (→ **page 1247**).

SKF Explorer performance class bearings have undergone, among other things, material and manufacturing improvements that require adjusted factors to calculate the dynamic load ratings in accordance with ISO 281.

Selecting bearing size

Static load ratings

The basic static load rating as defined in ISO 76 corresponds to a calculated contact stress at the centre of the most heavily loaded rolling element / raceway contact. The contact stress values are:

- 4 600 MPa for self-aligning ball bearings
- 4 200 MPa for all other ball bearings
- 4 000 MPa for all roller bearings

This stress produces a total permanent deformation of the rolling element and raceway, which is approximately 0,0001 of the rolling element diameter. The loads are purely radial for radial bearings and centrally acting axial loads for thrust bearings.

The basic static load rating C_0 is used under the following conditions:

- very slow rotational speeds ($n < 10$ r/min)
- very slow oscillating movements
- stationary bearings under load for extended periods

Verification of static bearing loads is performed by checking the static safety factor of the application, which is defined as

$$s_0 = \frac{C_0}{P_0}$$

where

s_0 = static safety factor

C_0 = basic static load rating [kN]

P_0 = equivalent static bearing load [kN]

The maximum load that can occur on a bearing should be used when calculating the equivalent static bearing load. For additional information about the recommended values for the safety factor and its calculation, refer to *Selecting bearing size using static load carrying capacity* (→ page 87).

Selecting bearing size using the life equations

Basic rating life

The basic rating life of a bearing in accordance with ISO 281 is

$$L_{10} = \left(\frac{C}{P} \right)^p$$

If the speed is constant, it is often preferable to calculate the life expressed in operating hours using

$$L_{10h} = \frac{10^6}{60 n} L_{10}$$

where

L_{10} = basic rating life (at 90% reliability) [million revolutions]

L_{10h} = basic rating life (at 90% reliability) [operating hours]

C = basic dynamic load rating [kN]

P = equivalent dynamic bearing load [kN] (→ page 85)

n = rotational speed [r/min]

p = exponent of the life equation

– for ball bearings, $p = 3$

– for roller bearings, $p = 10/3$

SKF rating life

For modern high quality bearings, the basic rating life can deviate significantly from the actual service life in a given application. Service life in a particular application depends on a variety of influencing factors including lubrication, the degree of contamination, proper installation and other environmental conditions.

Therefore, ISO 281 uses a modified life factor to supplement the basic rating life. The SKF life modification factor a_{SKF} applies the same concept of a fatigue load limit P_u as used in ISO 281. Values of P_u are listed in the product tables. Like ISO 281, the SKF life modification factor a_{SKF} takes the lubrication conditions (viscosity ratio κ , → page 71) and a factor η_c (→ page 74) for the contamination level into

consideration to reflect the operating conditions using

$$L_{nm} = a_1 a_{SKF} L_{10} = a_1 a_{SKF} \left(\frac{C}{P} \right)^p$$

If the speed is constant, the life can be expressed in operating hours using

$$L_{nmh} = \frac{10^6}{60 n} L_{nm}$$

where

L_{nm} = SKF rating life (at $100 - n^1$ % reliability) [million revolutions]

L_{nmh} = SKF rating life (at $100 - n^1$ % reliability) [operating hours]

L_{10} = basic rating life (at 90% reliability) [million revolutions]

a_1 = life adjustment factor for reliability (→ **table 1**, values in accordance with ISO 281)

a_{SKF} = SKF life modification factor (→ **diagrams 1 to 4**)

C = basic dynamic load rating [kN]

P = equivalent dynamic bearing load [kN]

n = rotational speed [r/min]

p = exponent of the life equation
 – for ball bearings, $p = 3$
 – for roller bearings, $p = 10/3$

Table 2 (→ **page 70**) provides commonly used conversion factors for bearing life in units other than million revolutions.

SKF life modification factor a_{SKF}

This factor represents the relationship between the fatigue load limit ratio (P_u/P), the lubrication condition (viscosity ratio κ) and the contamination level in the bearing (η_c). Values for the factor a_{SKF} can be obtained from four diagrams, depending on the bearing type, as a function of $\eta_c (P_u/P)$ for SKF standard and SKF Explorer bearings and for different values of the viscosity ratio κ . The diagrams are referenced in the following.

- for radial ball bearings (→ **diagram 1, page 66**)
- for radial roller bearings (→ **diagram 2, page 67**)
- for thrust ball bearings (→ **diagram 3, page 68**)
- for thrust roller bearings (→ **diagram 4, page 69**)

The diagrams are drawn for values and safety factors typically associated with fatigue load limits for other mechanical components. Considering the simplifications inherent in the SKF rating life equation, even if the operating conditions are accurately identified, it is not meaningful to use values of a_{SKF} in excess of 50.



Table 1

Values for life adjustment factor a_1

Reliability	Failure probability n	SKF rating life L_{nm}	Factor a_1
%	%	million revolutions	–
90	10	L_{10m}	1
95	5	L_{5m}	0,64
96	4	L_{4m}	0,55
97	3	L_{3m}	0,47
98	2	L_{2m}	0,37
99	1	L_{1m}	0,25

¹⁾ The factor n represents the failure probability, which is the difference between the requisite reliability and 100%.

Factor a_{SKF} for radial ball bearings

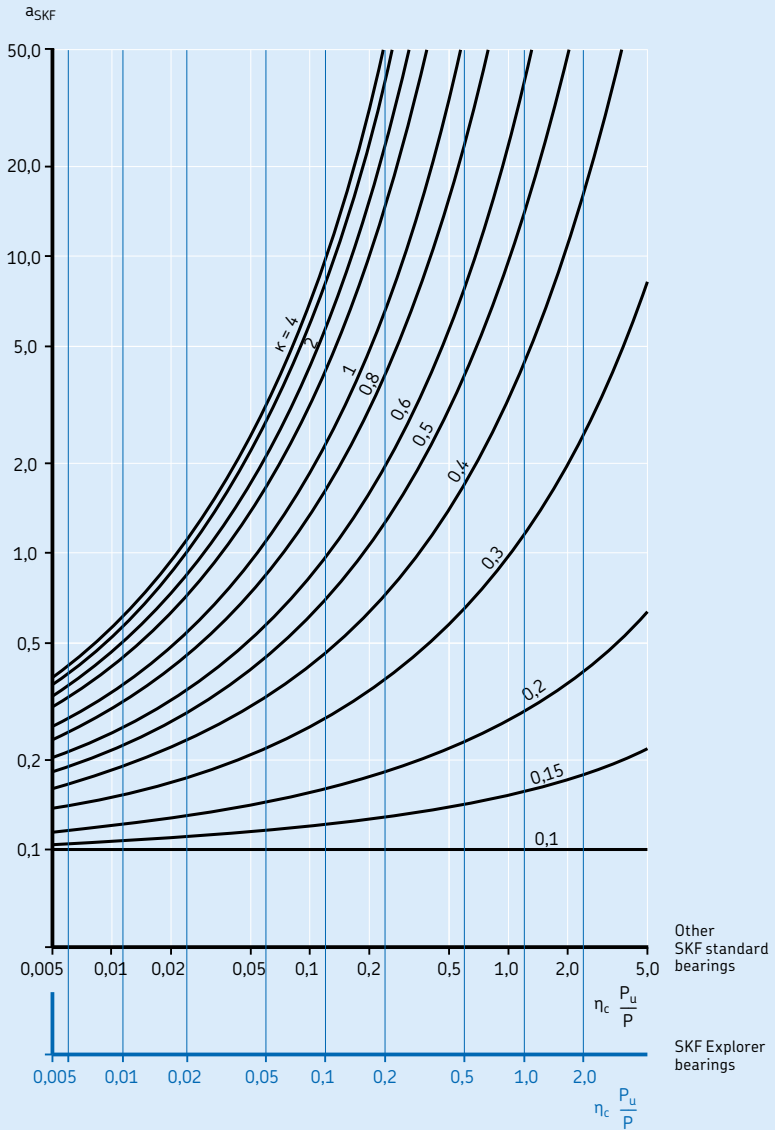

If $\kappa > 4$, use curve for $\kappa = 4$.

As the value of $\eta_c (P_u/P)$ tends to zero, a_{SKF} tends to 0,1 for all values of κ .

Diagram 2

Factor a_{SKF} for radial roller bearings

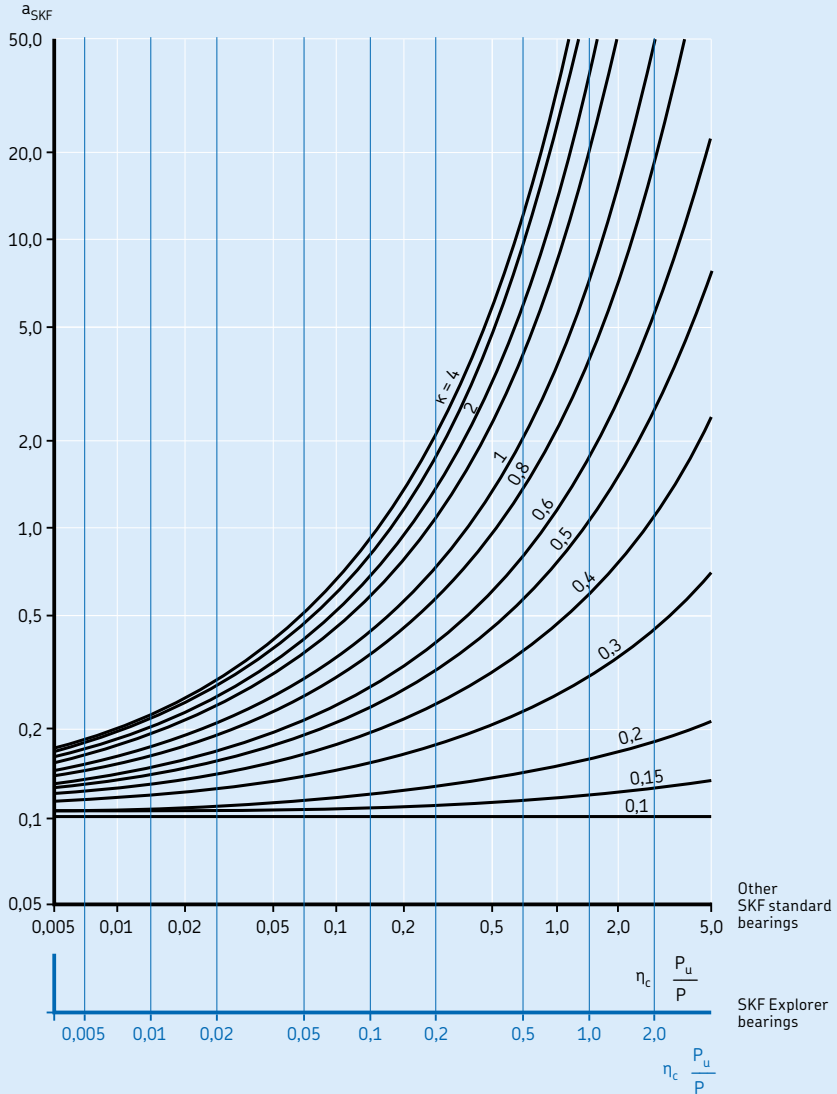

If $\kappa > 4$, use curve for $\kappa = 4$.

As the value of $\eta_c (P_u/P)$ tends to zero, a_{SKF} tends to 0,1 for all values of κ .



Factor a_{SKF} for thrust ball bearings

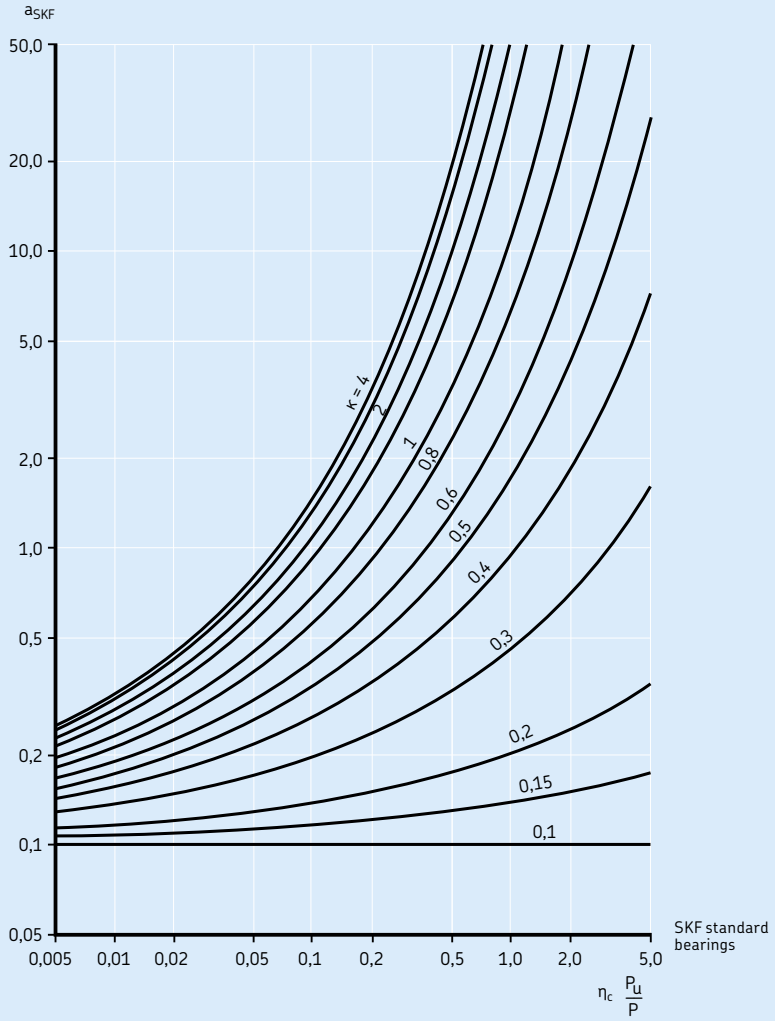

If $\kappa > 4$, use curve for $\kappa = 4$.

As the value of $\eta_c (P_u/P)$ tends to zero, a_{SKF} tends to 0,1 for all values of κ .

Diagram 4

Factor a_{SKF} for thrust roller bearings

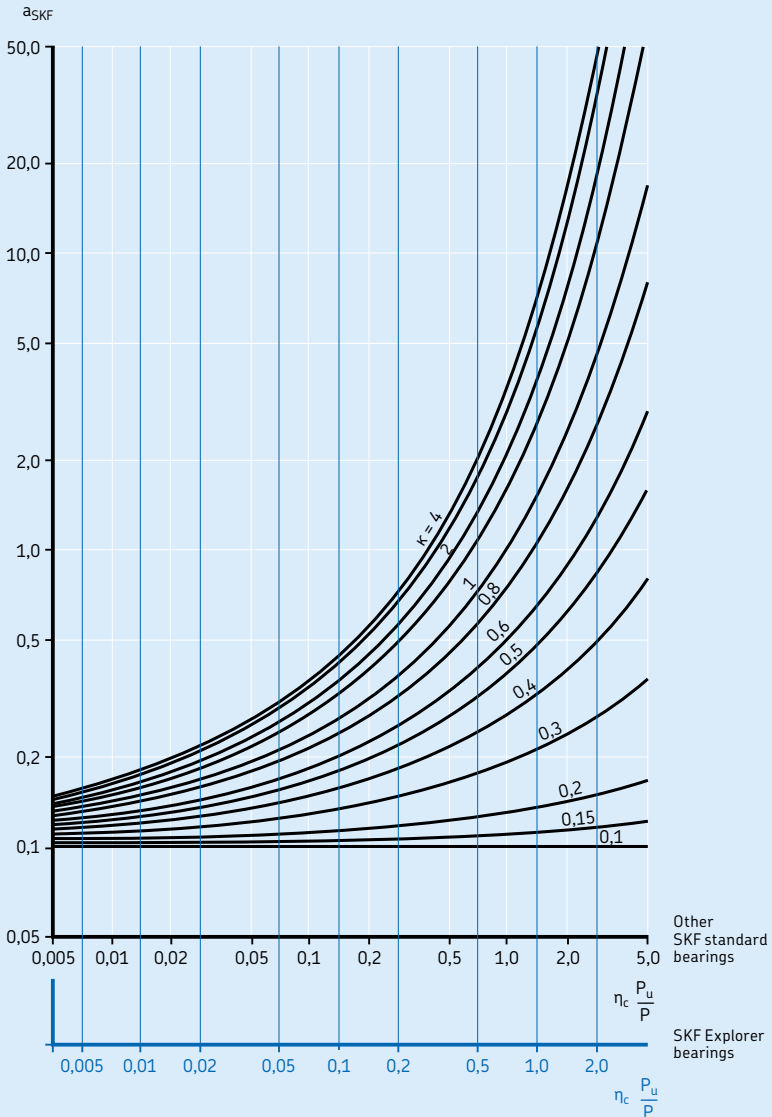

If $\kappa > 4$, use curve for $\kappa = 4$.

As the value of $\eta_c (P_u/P)$ tends to zero, a_{SKF} tends to 0,1 for all values of κ .



Selecting bearing size

Calculating the life modification factor a_{SKF}

SKF engineering programs like *SKF Bearing Select*, available online at skf.com/bearingselect can be used to calculate the factor a_{SKF} . Furthermore, SKF has also developed sophisticated computer programs incorporating the SKF rating life equation directly at the rolling contact stress level, permitting other factors influencing bearing life, such as misalignment, shaft deflection and housing deformation, to be taken into account (→ *SKF calculation tools*, page 92).

Table 2

Units conversion factors for bearing life

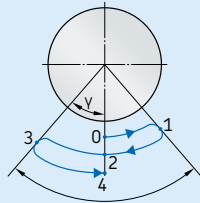

The complete oscillation = 4γ
(= from point 0 to point 4)

Basic units	Conversion factor Million revolutions	Operating hours	Million kilometres travelled	Million oscillation cycles ¹⁾
1 million revolutions	1	$\frac{10^6}{60 n}$	$\frac{\pi D}{10^3}$	$\frac{180}{2 \gamma}$
1 operating hour	$\frac{60 n}{10^6}$	1	$\frac{60 n \pi D}{10^9}$	$\frac{180 \times 60 n}{2 \gamma 10^6}$
1 million kilometres	$\frac{10^3}{\pi D}$	$\frac{10^9}{60 n \pi D}$	1	$\frac{180 \times 10^3}{2 \gamma \pi D}$
1 million oscillation cycles ¹⁾	$\frac{2 \gamma}{180}$	$\frac{2 \gamma 10^6}{180 \times 60 n}$	$\frac{2 \gamma \pi D}{180 \times 10^3}$	1

D = vehicle wheel diameter [m]

n = rotational speed [r/min]

γ = oscillation amplitude (angle of max. deviation from centre position) [°]

¹⁾ Not valid for small amplitudes ($\gamma < 10^\circ$).

Lubrication conditions – the viscosity ratio κ

The effectiveness of a lubricant is primarily determined by the degree of surface separation between the rolling contact surfaces. If an adequate lubricant film is to be formed, the lubricant must have a given minimum viscosity when the application has reached its operating temperature. The condition of the lubricant is described by the viscosity ratio κ as the ratio of the actual viscosity ν to the rated viscosity ν_1 for adequate lubrication, when the lubricant is at normal operating temperature (→ *Selecting lubricating oils*, page 266). It follows from using

$$\kappa = \frac{\nu}{\nu_1}$$

where

κ = viscosity ratio

ν = actual operating viscosity of the lubricant [mm²/s]

ν_1 = rated viscosity of the lubricant depending on the bearing mean diameter and rotational speed [mm²/s]

The rated viscosity ν_1 , required for adequate lubrication (→ *Viscosity ratio κ* , page 241), can be determined from **diagram 5** (→ page 72), using the bearing mean diameter $d_m = 0,5 (d + D)$ [mm] and the rotational speed of the bearing n [r/min]. This diagram takes the latest findings of tribology in rolling bearings into account.

When the operating temperature is known from experience or can otherwise be determined, the corresponding viscosity at the internationally standardized reference temperature of 40 °C (105 °F) can be obtained from **diagram 6** (→ page 73), or can be calculated. The diagram is compiled for a viscosity index of 95. **Table 3** lists the viscosity grades in accordance with ISO 3448 showing the viscosity range for each grade at 40 °C (105 °F). Certain bearing types like spherical roller bearings, tapered roller bearings and spherical roller thrust bearings, normally have a higher operating temperature than other bearing types, such as deep groove ball bearings and cylindrical roller bearings, under comparable operating conditions.

Table 3

Viscosity classification in accordance with ISO 3448

Viscosity grade	Kinematic viscosity limits at 40 °C (105 °F)		
	mean	min.	max.
–	mm ² /s		
ISO VG 2	2,2	1,98	2,42
ISO VG 3	3,2	2,88	3,52
ISO VG 5	4,6	4,14	5,06
ISO VG 7	6,8	6,12	7,48
ISO VG 10	10	9,00	11,0
ISO VG 15	15	13,5	16,5
ISO VG 22	22	19,8	24,2
ISO VG 32	32	28,8	35,2
ISO VG 46	46	41,4	50,6
ISO VG 68	68	61,2	74,8
ISO VG 100	100	90,0	110
ISO VG 150	150	135	165
ISO VG 220	220	198	242
ISO VG 320	320	288	352
ISO VG 460	460	414	506
ISO VG 680	680	612	748
ISO VG 1 000	1 000	900	1 100
ISO VG 1 500	1 500	1 350	1 650

Selecting bearing size

Calculation example

A bearing with a bore diameter $d = 340$ mm and an outside diameter $D = 420$ mm is required to operate at a speed $n = 500$ r/min. Since $d_m = 0,5 (d + D) = 380$ mm, from **diagram 5**, the minimum rated viscosity ν_1 required to provide adequate lubrication at the operating temperature is approximately $11 \text{ mm}^2/\text{s}$. From **diagram 6**, assuming that the operating temperature of the bearing is 70°C (160°F), a lubricant in the ISO VG 32

viscosity class, with an actual viscosity ν of at least $32 \text{ mm}^2/\text{s}$ at the reference temperature of 40°C (105°F), is required.

Diagram 5

Estimation of the rated viscosity ν_1 at operating temperature

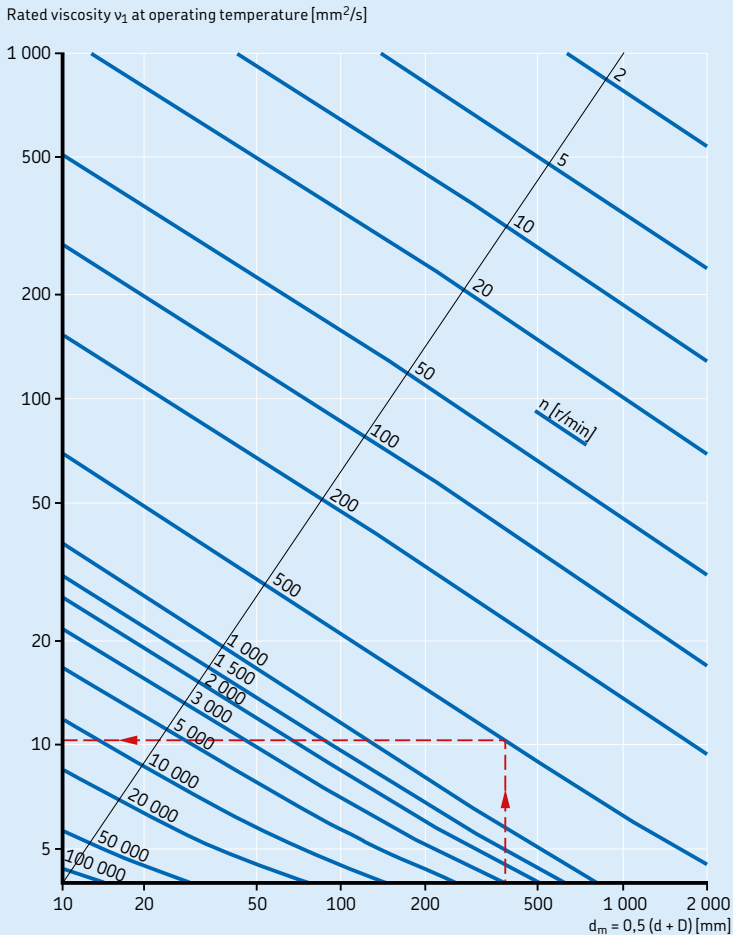

Considering EP additives

EP additives in the lubricant can extend bearing service life when, in accordance with ISO 281, $\kappa < 1$ and the factor for the contamination level $\eta_c \geq 0,2$. Under these conditions, a value of $\kappa = 1$ can be applied in the calculation of a_{SKF} , if a proven lubricant with effective EP additives is used. In this case, the life modification factor has to be limited to $a_{SKF} \leq 3$, but should never be lower than a_{SKF} for normal lubricants.

For the remaining range, the life modification factor a_{SKF} can be determined using the actual κ of the application. In case of severe contamination, i.e. contamination factor $\eta_c < 0,2$, the possible benefit of an EP additive should be proven by testing. Refer to the information about EP additives under *Lubrication* (→ page 239).



Diagram 6

Viscosity-temperature diagram for ISO viscosity grades
(Mineral oils, viscosity index 95)

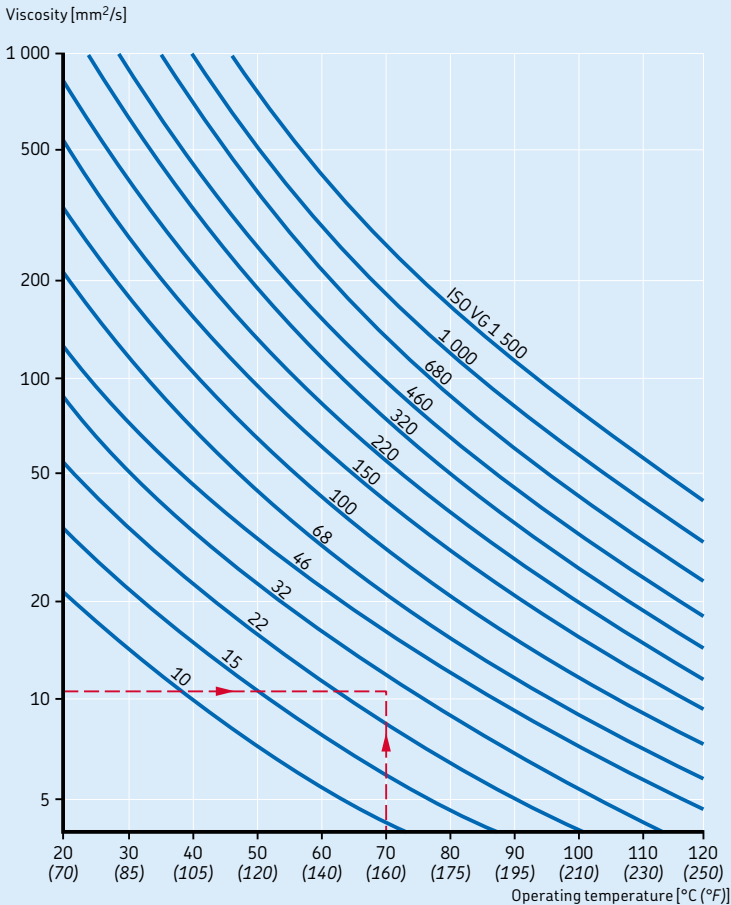

Selecting bearing size

Factor η_c for contamination level

This factor was introduced to consider the contamination level of the lubricant in the bearing life calculation. The influence of contamination on bearing fatigue depends on a number of parameters including bearing size, relative lubricant film thickness, size and distribution of solid contaminant particles and types of contaminants (soft, hard etc.). The influence of these parameters on bearing life is complex and many of the parameters are difficult to quantify. It is therefore not possible to allocate precise values to η_c that would have general validity. However, some guideline values in accordance with ISO 281 are listed in **table 4**.

ISO contamination classification and filter rating

The standard method for classifying the contamination level in a lubrication system is described in ISO 4406. In this classification system, the result of the solid particle count is converted into a code using a scale number (→ **table 5** and **diagram 7, pages 75 and 78**).

One method to check the contamination level of bearing oil is the microscope counting method. This method uses two particle size ranges: $\geq 5 \mu\text{m}$ and $\geq 15 \mu\text{m}$. Another more modern method is to use an optical automatic particle counter in accordance with ISO 11171. The calibration scale of the automatic counting method differs from that of the microscopic counting method. It uses three particle size ranges indicated by the symbol (c) e.g. $\geq 4 \mu\text{m}(c)$,

Table 4

Guideline values for factor η_c for different levels of contamination

Conditions	Factor η_c ¹⁾ for bearings with mean diameter	
	$d_m < 100 \text{ mm}$	$d_m \geq 100 \text{ mm}$
Extreme cleanliness <ul style="list-style-type: none"> particle size approximately the same as the lubricant film thickness laboratory conditions 	1	1
High cleanliness <ul style="list-style-type: none"> oil filtered through an extremely fine filter typical conditions: sealed bearings that are greased for life 	0,8 ... 0,6	0,9 ... 0,8
Normal cleanliness <ul style="list-style-type: none"> oil filtered through a fine filter typical conditions: shielded bearings that are greased for life 	0,6 ... 0,5	0,8 ... 0,6
Slight contamination <ul style="list-style-type: none"> typical conditions: bearings without integral seals, coarse filtering, wear particles and slight ingress of contaminants 	0,5 ... 0,3	0,6 ... 0,4
Typical contamination <ul style="list-style-type: none"> conditions typical of bearings without integral seals, coarse filtering, wear particles and ingress from surroundings 	0,3 ... 0,1	0,4 ... 0,2
Severe contamination <ul style="list-style-type: none"> typical conditions: high levels of contamination due to excessive wear and/or ineffective seals bearing arrangement with ineffective or damaged seals 	0,1 ... 0	0,1 ... 0
Very severe contamination <ul style="list-style-type: none"> typical conditions: contamination levels so severe that values of η_c are outside the scale, which significantly reduces the bearing life 	0	0

¹⁾ The scale for η_c refers only to typical solid contaminants. Contaminants like water or other fluids detrimental to bearing life is not included. Due to strong abrasive wear in highly contaminated environments ($\eta_c = 0$) the useful life of a bearing can be significantly shorter than the rated life.

$\geq 6 \mu\text{m}(c)$ and $\geq 14 \mu\text{m}(c)$. Typically, only the two larger particle size ranges are used, as the larger particles have a more significant impact on bearing fatigue.

Typical examples of contamination level classifications for lubricating oils are -/15/12 (A) or 22/18/13 (B), as shown in **diagram 7** (→ **page 78**).

Example A indicates that the oil contains between 160 and 320 particles $\geq 5 \mu\text{m}$ and between 20 and 40 particles $\geq 15 \mu\text{m}$ per millilitre of oil. Though it would be optimal if lubricating oils were continuously filtered, the viability of a filtration system would depend on the equipment costs versus maintenance and downtime costs.

A filter rating is an indication of filter efficiency and is expressed as a reduction factor (β). The higher the β value, the more efficient the filter is for the specified particle size. The filter rating β is expressed as a ratio between the number of specified particles before and after filtering. This can be calculated using

$$\beta_{x(c)} = \frac{n_1}{n_2}$$

where

- $\beta_{x(c)}$ = filter rating related to a specified particle size x
- x = particle size (c) [μm] based on the automatic particle counting method, calibrated in accordance with ISO 11171
- n_1 = number of particles per volume unit larger than x , upstream the filter
- n_2 = number of particles per volume unit larger than x , downstream the filter

NOTE: The filter rating β only relates to one particle size in μm , which is shown in the index such as $\beta_{3(c)}$, $\beta_{6(c)}$, $\beta_{12(c)}$, etc. For example, a complete rating " $\beta_{6(c)} = 75$ " means that only 1 in 75 particles, $6 \mu\text{m}$ or larger passes through the filter.



Table 5

ISO classification – allocation of scale number		
Number of particles per millilitre oil over	incl.	Scale number
2 500 000		> 28
1 300 000	2 500 000	28
640 000	1 300 000	27
320 000	640 000	26
160 000	320 000	25
80 000	160 000	24
40 000	80 000	23
20 000	40 000	22
10 000	20 000	21
5 000	10 000	20
2 500	5 000	19
1 300	2 500	18
640	1 300	17
320	640	16
160	320	15
80	160	14
40	80	13
20	40	12
10	20	11
5	10	10
2,5	5	9
1,3	2,5	8
0,64	1,3	7
0,32	0,64	6
0,16	0,32	5
0,08	0,16	4
0,04	0,08	3
0,02	0,04	2
0,01	0,02	1
0,00	0,01	0

Selecting bearing size

Determining η_c when the contamination level is known

Once the oil contamination level is known, either from the microscope counting method or the automatic particle counting method, both in accordance with ISO 4406, or indirectly as a result of the filtration ratio that is applied in an oil circulation system, this information can be used to determine the factor η_c . Note that the factor η_c cannot be derived solely from a particle count. It depends largely on the lubrication conditions, such as κ , and the size of the bearing. A simplified method in accordance with ISO 281 is presented here to obtain the η_c factor for a given application. From the oil contamination code (or filtration ratio of the application), the contamination factor η_c is obtained, using the bearing mean diameter $d_m = 0,5 (d + D)$ [mm] and the viscosity ratio κ for that bearing (→ **diagrams 8 and 9, page 79**).

Diagrams 8 and 9 provide typical values for the factor η_c for circulating oil lubrication systems with different degrees of oil filtration and oil contamination codes. Similar contamination factors can be applied in applications where an oil bath shows virtually no increase in the contamination particles present in the system. On the other hand, if the number of particles in an oil bath continues to increase over time, due to excessive wear or the ingress of contaminants, this must be reflected in the choice of the factor η_c used for the oil bath system as indicated in ISO 281.

For grease lubrication, η_c can be determined in a similar way using ISO values for five levels of contamination as shown in **table 6**.

Diagrams 10 and 11 (→ page 80), provide typical values for the factor η_c for grease lubrication for high and normal cleanliness (→ **table 6**).

Table 6

Factors to determine contamination levels for a grease lubricated application in accordance with ISO 281

Contamination level	Operating conditions	c_1	c_2
High cleanliness	<ul style="list-style-type: none"> very clean assembly; very good sealing system relative to the operating conditions; relubrication is continuous or at short intervals sealed bearings that are greased for life, with appropriate sealing capacity for the operating conditions 	0,0864	0,6796
Normal cleanliness	<ul style="list-style-type: none"> clean assembly; good sealing system relative to the operating conditions; relubrication according to manufacturer's specifications shielded bearings that are greased for life with appropriate sealing capacity for the operating conditions 	0,0432	1,141
Slight to typical contamination	<ul style="list-style-type: none"> clean assembly; moderate sealing capacity relative to the operating conditions; relubrication according to manufacturer's specifications 	0,0177	1,887 ¹⁾
Severe contamination	<ul style="list-style-type: none"> assembly in workshop; bearing and application not adequately washed prior to mounting; ineffective seal relative to the operating conditions; relubrication intervals longer than recommended by manufacturer 	0,0115	2,662
Very severe contamination	<ul style="list-style-type: none"> assembly in contaminated environment; inadequate sealing system; too long relubrication intervals 	0,00617	4,06

¹⁾ When $d_m \geq 500$ mm, use 1,677

For other degrees of contamination or in the most general case of circulating oil, oil bath and grease lubrication, the contamination factor for a bearing arrangement can be determined using the simplified equation

$$\eta_c = \min (c_1 \kappa^{0,68} d_m^{0,55}, 1) \left[1 - \left(\frac{c_2}{3\sqrt{d_m}} \right) \right]$$

min (#1, #2) = use the smallest of the two values

where c_1 and c_2 are constants characterizing the cleanliness of the oil in accordance with ISO 4406, or of the grease according to the classifications in **table 6**. Note that in case of oil filtration, the corresponding level of filtration efficiency (in accordance with ISO 16689) (→ **table 7**) can also be applied in place of the metrological characterization of the status of cleanliness of the oil.



Table 7

Factors to determine contamination levels for an oil lubricated application in accordance with ISO 281

Filtration ratio $\beta_{x(c)}$	ISO 4406 Basic code	Circulating oil lubrication with in-line filters		Oil lubrication without filtration or with off-line filters	
		c_1	c_2	c_1	c_2
$\beta_{6(c)} = 200$	-/13/10	0,0864	0,5663	0,0864	0,5796
$\beta_{12(c)} = 200$	-/15/12	0,0432	0,9987	0,0288	1,141
$\beta_{25(c)} = 75$	-/17/14	0,0288	1,6329	0,0133	1,67
$\beta_{40(c)} = 75$	-/19/16	0,0216	2,3362	0,00864	2,5164
-	-/21/18	-	-	0,00411	3,8974

ISO classification of contamination level and examples for particle counting

Number of particles per millilitre of oil larger than indicated size

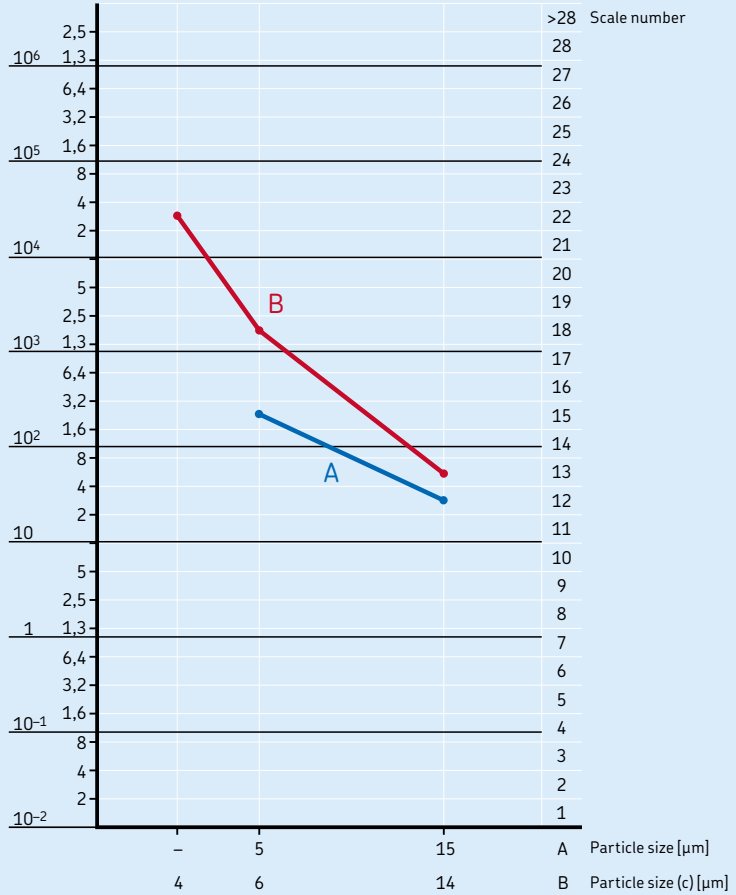

A = microscope particle count (-/15/12)
 B = automatic particle count (22/18/13)

Diagram 8

Contamination factor η_c for
 – circulating oil lubrication
 – solid contamination level –/15/12 in accordance with ISO 4406
 – filter rating $\beta_{12(c)} = 200$

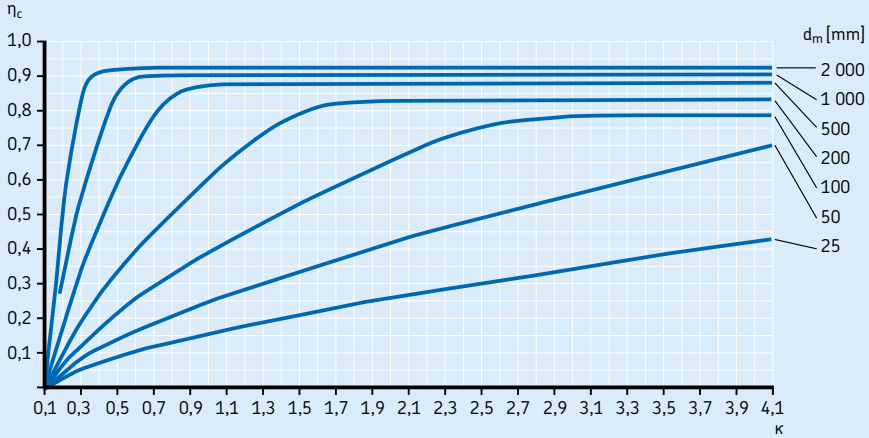

B

Diagram 9

Contamination factor η_c for
 – circulating oil lubrication
 – solid contamination level –/17/14 in accordance with ISO 4406
 – filter rating $\beta_{25(c)} = 75$

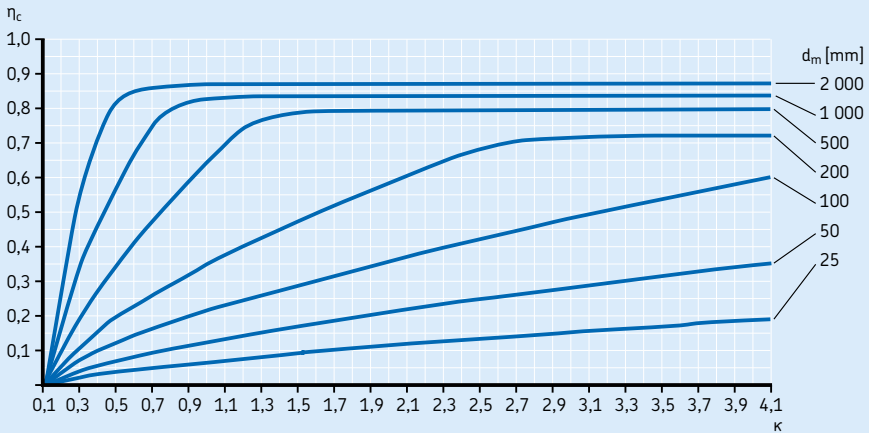

Selecting bearing size

Diagram 10

Contamination factor η_c for grease lubrication, high cleanliness

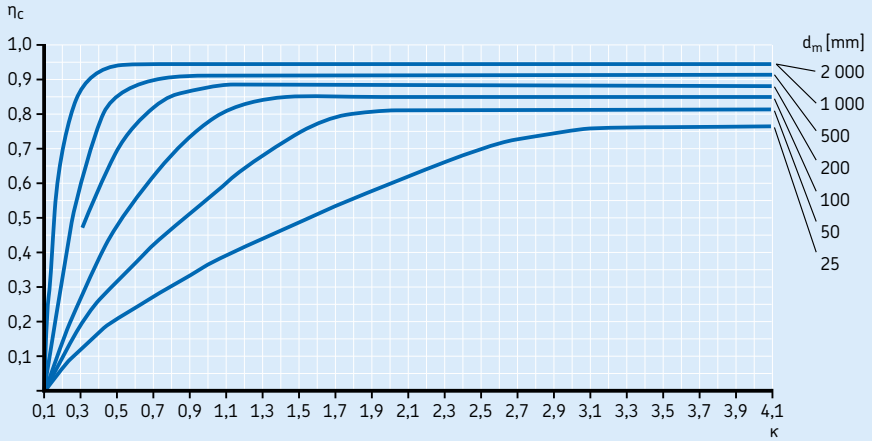
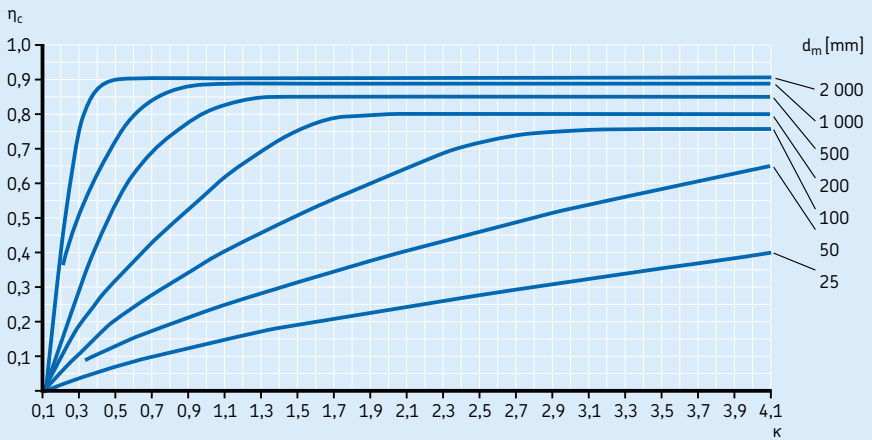

Diagram 11

Contamination factor η_c for grease lubrication, normal cleanliness



Calculating life with variable operating conditions

In some applications, like industrial gearboxes, the operating conditions, such as the magnitude and direction of loads, speeds, temperatures and lubrication conditions are continually changing. In these types of applications, bearing life cannot be calculated without first reducing the load spectrum or duty cycle of the application to a limited number of simpler load cases (→ **diagram 12**). In case of continuously changing load, each different load level can be accumulated and the load spectrum reduced to a histogram of constant load blocks. Each block should characterize a given percentage or time-fraction during operation. Note that heavy and normal loads consume bearing life at a faster rate than light loads. Therefore, it is important to have shock and peak loads well represented in the load diagram, even if the occurrence of these loads is relatively rare and limited to a few revolutions.

Within each duty interval, the bearing load and operating conditions can be averaged to some constant value. The number of operating hours or revolutions expected from each duty interval showing the life fraction required by that particular load condition should also be included. Therefore, if N_1 equals the number of revolutions required under the load condition P_1 , and N is the expected number of revolutions for the completion of all variable loading cycles, then the cycle fraction $U_1 = N_1/N$ is used by the load condition P_1 , which has a calculated life of L_{10m1} . Under variable operating conditions, bearing life can be rated using

$$L_{10m} = \frac{1}{\frac{U_1}{L_{10m1}} + \frac{U_2}{L_{10m2}} + \frac{U_3}{L_{10m3}} + \dots}$$

where
 L_{10m} = SKF rating life (at 90% reliability) [million revolutions]
 $L_{10m1}, L_{10m2}, \dots$ = SKF rating lives (at 90% reliability) under constant conditions 1, 2, ... [million revolutions]
 U_1, U_2, \dots = life cycle fraction under the conditions 1, 2, ...
 Note: $U_1 + U_2 + \dots U_n = 1$

The use of this calculation method depends very much on the availability of representative load diagrams for the application. Note that this type of load history can also be derived from a similar type of application.



Diagram 12

Duty intervals with constant bearing load P and number of revolutions N

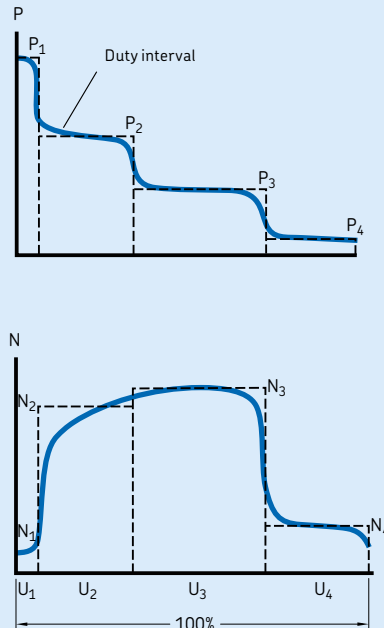

Selecting bearing size

Influence of the operating temperature

In operation, the dimensions of a bearing change as a result of structural transformations within the material. These transformations are influenced by temperature, time and stress.

To avoid inadmissible dimensional changes as a result of structural transformation, bearing components undergo a special heat treatment (→ **table 8**).

Depending on the bearing type, standard bearings made of steels for through-hardening or induction-hardening have a recommended maximum operating temperature between 120 and 200 °C (250 and 390 °F). These maximum operating temperatures are directly related to the heat treatment that was applied. For additional information, refer to the introductory text of the relevant product chapter. If the normal operating temperatures of the application are higher than the recommended temperature limit, a bearing with a higher stabilization class should be considered. For applications where bearings operate continuously at elevated temperatures, the dynamic load carrying capacity of the bearing may need to be adjusted in the life calculations. For additional information, contact the SKF application engineering service.

The satisfactory operation of bearings at elevated temperatures also depends on whether the lubricant retains its lubricating properties and whether the materials used for the seals, cages etc. are suitable (→ *Lubrication*, **page 239**, and *Materials for rolling bearings*, **page 150**).

For bearings operating at high temperatures requiring a higher stabilization class than S1, contact the SKF application engineering service.

Requisite rating life

When determining bearing size, verify the calculated SKF rating life with the specification life of the application, if it is available. This usually depends on the type of machine and the requirements regarding duration of service and operational reliability. In the absence of previous experience, the guideline values listed in **tables 9** and **10** can be used.

Table 8

Dimensional stability	Stabilized up to	
	°C	°F
–		
SN	120	250
S0	150	300
S1	200	390
S2	250	480
S3	300	570
S4	350	660

Table 9

Guideline values of specification life for different machine types

Machine type	Specification life Operating hours
Household machines, agricultural machines, instruments, technical equipment for medical use	300 ... 3 000
Machines used for short periods or intermittently: electric hand tools, lifting tackle in workshops, construction equipment and machines	3 000 ... 8 000
Machines used for short periods or intermittently where high operational reliability is required: lifts (elevators), cranes for packaged goods or slings of drums etc.	8 000 ... 12 000
Machines for use 8 hours a day, but not always fully utilized: gear drives for general purposes, electric motors for industrial use, rotary crushers	10 000 ... 25 000
Machines for use 8 hours a day and fully utilized: machine tools, woodworking machines, machines for the engineering industry, cranes for bulk materials, ventilator fans, conveyor belts, printing equipment, separators and centrifuges	20 000 ... 30 000
Machines for continuous 24 hour use: rolling mill gear units, medium-size electrical machinery, compressors, mine hoists, pumps, textile machinery	40 000 ... 50 000
Wind energy machinery, this includes main shaft, yaw, pitching gearbox, generator bearings	30 000 ... 100 000
Water works machinery, rotary furnaces, cable stranding machines, propulsion machinery for ocean-going vessels	60 000 ... 100 000
Large electric machines, power generation plant, mine pumps, mine ventilator fans, tunnel shaft bearings for ocean-going vessels	> 100 000



Table 10

Guideline values of specification life for axlebox bearings and units for railway vehicles

Type of vehicle	Specification life Million kilometres
Freight wagons to UIC specification based on continuously acting maximum axle load	0,8
Mass transit vehicles: suburban trains, underground carriages, light rail and tramway vehicles	1,5
Main line passenger coaches	3
Main line diesel and electric multiple units	3 ... 4
Main line diesel and electric locomotives	3 ... 5

Dynamic bearing loads

Calculating dynamic bearing loads

The loads acting on a bearing can be calculated according to the laws of mechanics if the external forces, such as forces from power transmission, work forces or inertial forces, are known or can be calculated. When calculating the load components for a single bearing, the shaft is considered as a beam resting on rigid, moment-free supports for the sake of simplification. Elastic deformations in the bearing, the housing or the machine frame are not considered, nor are the moments produced in the bearing as a result of shaft deflection.

These simplifications are necessary if a bearing arrangement is to be calculated without a computer program. The standardized methods for calculating basic load ratings and equivalent bearing loads are based on similar assumptions.

It is possible to calculate bearing loads based on the theory of elasticity, without making the above assumptions, but this requires the use of complex computer programs. In these programs, the bearings, shaft and housing are considered as resilient components of a system.

If external forces and loads like inertial forces or loads resulting from the weight of a shaft and its components are not known, they can be calculated. However, when determining work forces and loads, e.g. rolling forces, moment loads, unbalanced loads and shock loads, it may be necessary to rely on estimates based on experience with similar machines or bearing arrangements.

Geared transmissions

With geared transmissions, the theoretical tooth forces can be calculated from the power transmitted and the design characteristics of the gear teeth. However, there are additional dynamic forces, produced either by the gear, or by the input or output shaft. Additional dynamic forces from gears can be the result of form errors of the teeth and from unbalanced rotating components. Because of the requirements for quiet running, gears are made to such a high level of accuracy that these forces are generally negligible, and not considered when making bearing calculations.

Additional forces arising from the type and mode of operation of the machines coupled to the transmission can only be determined when the operating conditions are known. Their influence on the rating lives of the bearings is considered using an "operation" factor that takes shock loads and the efficiency of the gears into account. Values of this factor for different operating conditions can usually be found in information published by the gear manufacturer.

Belt drives

When calculating bearing loads for belt driven applications, "belt pull" must be taken into consideration. Belt pull, which is a circumferential load, depends on the amount of torque being transmitted. The belt pull must be multiplied by a factor, which depends on the type of belt, belt tension and any additional dynamic forces. Belt manufacturers usually publish values. However, should information not be available, the following values can be used:

- toothed belts = 1,1 to 1,3
- V-belts = 1,2 to 2,5
- plain belts = 1,5 to 4,5

The larger values apply when the distance between shafts is short, for heavy or shock-type duty, or where belt tension is high.

Equivalent dynamic bearing load

The above information can be used to calculate the bearing load F . When the bearing load fulfills the requirements for the basic dynamic load rating C , i.e. the load is constant in magnitude and direction and acts radially on a radial bearing or axially and centrally on a thrust bearing, then $P = F$ and the load may be inserted directly into the life equations.

In all other cases, the equivalent dynamic bearing load must be calculated first. The equivalent dynamic bearing load is defined as that hypothetical load, constant in magnitude and direction, acting radially on a radial bearing or axially and centrally on a thrust bearing which, if applied, would have the same influence on bearing life as the actual loads to which the bearing is subjected (→ **fig. 2**).

Radial bearings are often subjected to simultaneously acting radial and axial loads. If the resultant load is constant in magnitude and direction, the equivalent dynamic bearing load P can be obtained from the general equation

$$P = X F_r + Y F_a$$

where

P = equivalent dynamic bearing load [kN]

F_r = actual radial bearing load [kN]

F_a = actual axial bearing load [kN]

X = radial load factor for the bearing

Y = axial load factor for the bearing

An additional axial load only influences the equivalent dynamic load P for a single row

radial bearing if the ratio F_a/F_r exceeds a certain limiting factor e . With double row bearings, even light axial loads are generally significant.

The same general equation also applies to spherical roller thrust bearings, which can accommodate both axial and radial loads. Other thrust bearings like thrust ball bearings and cylindrical and needle roller thrust bearings, can accommodate pure axial loads only. For these bearings, provided the load acts centrally, the equation can be simplified to

$$P = F_a$$

Information and data required for calculating the equivalent dynamic bearing load is provided in the relevant product chapter.

Fluctuating bearing load

In many cases, the magnitude of the load fluctuates. The formula to calculate fluctuating loads can be found under *Calculating life with variable operating conditions* (→ **page 81**).

Mean load within a duty interval

Within each loading interval the operating conditions can vary slightly from the nominal value. Assuming that the operating conditions like speed and load direction are fairly constant and the magnitude of the load constantly varies between a minimum value F_{\min} and a maximum value F_{\max} (→ **diagram 13, page 86**), the mean load can be obtained from

$$F_m = \frac{F_{\min} + 2 F_{\max}}{3}$$

Fig. 2

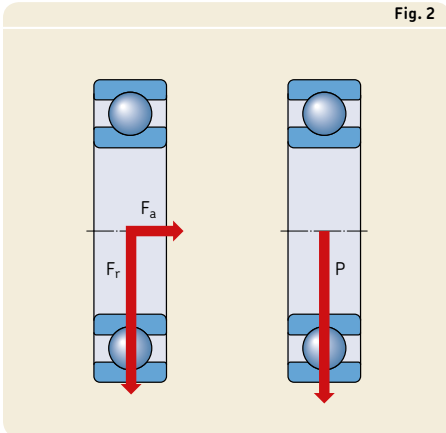

Selecting bearing size

Diagram 13

Load averaging

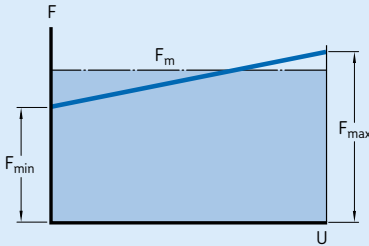

Rotating load

If, as illustrated in **diagram 14**, the load on a bearing consists of a load F_1 , which is constant in magnitude and direction, such as the weight of a rotor, and a rotating constant load F_2 , such as an unbalance load, the mean load can be obtained from

$$F_m = f_m (F_1 + F_2)$$

Values for the factor f_m are provided in **diagram 15**.

Requisite minimum load

The correlation between load and service life is less important for applications where there are very light loads. Failure mechanisms other than fatigue often prevail.

To provide satisfactory operation, ball and roller bearings must always be subjected to a given minimum load. A general “rule of thumb” indicates that minimum loads corresponding to 0,02 C should be imposed on roller bearings and minimum loads corresponding to 0,01 C on ball bearings. The importance of applying a minimum load increases in applications where there are rapid accelerations or rapid starts and stops, and where speeds exceed 50% of the limiting speeds listed in the product tables (→ *Speeds*, **page 117**). If minimum load requirements cannot be met, NoWear coated bearings should be considered (→ **page 1241**).

Recommendations for calculating the requisite minimum load for different bearing types are provided in the relevant product chapter.

Diagram 14

Rotating load

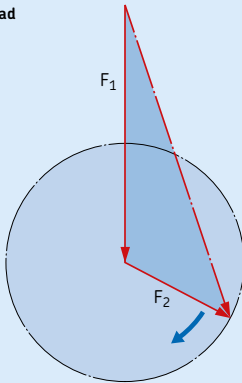
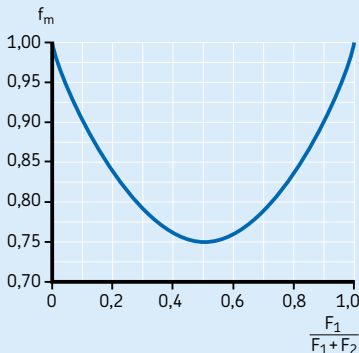

Diagram 15

Rotating load



Selecting bearing size using static load carrying capacity

Bearing size should be selected on the basis of static load ratings C_0 instead of on bearing life when one of the following conditions exist:

- The bearing is stationary and is subjected to continuous or intermittent (shock) loads.
- The bearing makes slow oscillating or alignment movements under load.
- The bearing rotates under load at very slow speed ($n < 10$ r/min) and is only required to have a short life. In other words, the life equation in this case, for a given equivalent load P , would give such a low requisite basic dynamic load rating C , that the bearing selected on a life basis would be seriously overloaded in service.
- The bearing rotates and, in addition to the normal operating loads, has to sustain heavy shock loads.

In all these cases, the permissible load for the bearing is the maximum load the bearing can accommodate without permanent deformation to the rolling elements or raceways. Permanent deformation is typically caused by:

- heavy loads acting on the bearing while it is stationary or oscillating slowly
- heavy shock loads acting on the bearing while it is rotating

Depending on the operating conditions and load, the resulting damage can be flattened areas on the rolling elements or indentations on the raceways. The indentations can be irregularly spaced around the raceway, or may be evenly spaced at positions corresponding to the spacing of the rolling elements.

Permanent deformations usually lead to higher vibration and/or noise levels and increased friction. It is also possible that the internal clearance will increase or the character of the fits may be changed.

The extent to which these changes are detrimental to bearing performance depends on the demands placed on the bearing in a particular application. It is therefore necessary to make sure that permanent deformations do not occur, or only occur to a very limited extent by selecting a bearing with sufficiently high static load carrying capacity, if one of the following demands has to be satisfied:

- high reliability
- quiet running, such as for electric motors
- vibration-free operation, such as for machine tools
- constant bearing frictional moment, such as for measuring apparatus and test equipment
- low starting friction under load, such as for cranes

B

Selecting bearing size

Equivalent static bearing load

Static loads comprising radial and axial components must be converted into an equivalent static bearing load. This is defined as that hypothetical load (radial for a radial bearing and axial for a thrust bearing) which, if applied, would cause the same maximum rolling element load in the bearing as the actual loads to which the bearing is subjected. It is obtained from the general equation

$$P_0 = X_0 F_r + Y_0 F_a$$

where

P_0 = equivalent static bearing load [kN]

F_r = actual radial bearing load (see below) [kN]

F_a = actual axial bearing load (see below) [kN]

X_0 = radial load factor for the bearing

Y_0 = axial load factor for the bearing

Information and data required for calculating the equivalent static bearing load is provided in the relevant product chapter.

When calculating P_0 , the maximum load that can occur should be used and its radial and axial components (→ **fig. 3**) inserted in the equation above. If a static load acts in different directions on a bearing, the magnitude of these components changes. In these cases, the components of the load with the highest value of the equivalent static bearing load P_0 should be used.

Required basic static load rating

When determining bearing size based on the static load carrying capacity, a given safety factor s_0 , which represents the relationship between the basic static load rating C_0 and the equivalent static bearing load P_0 , is used to calculate the requisite basic static load rating.

The required basic static load rating C_0 can be determined from

$$C_0 = s_0 P_0$$

where

C_0 = basic static load rating [kN]

P_0 = equivalent static bearing load [kN]

s_0 = static safety factor

Guideline values for the static safety factor s_0 based on experience are listed in **table 11**. At elevated temperatures, the static load carrying capacity is reduced. For additional information, contact the SKF application engineering service.

Fig. 3

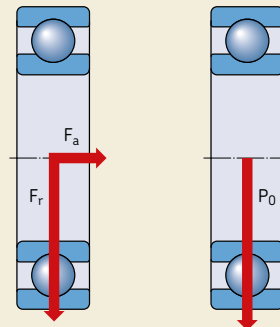

Checking the static load carrying capacity

For dynamically loaded bearings, where the equivalent static bearing load P_0 is known, it is advisable to check that the static load carrying capacity is adequate using

$$s_0 = \frac{C_0}{P_0}$$

If the s_0 value obtained is less than the recommended guideline value (→ **table 11**), a bearing with a higher basic static load rating should be selected.

B

Table 11

Guideline values for the static safety factor s_0

Type of operation	Rotating bearing						Non-rotating bearing	
	Performance requirements (e.g. quiet running or vibration-free operation)							
	unimportant		normal		high			
	Ball bearings	Roller bearings	Ball bearings	Roller bearings	Ball bearings	Roller bearings	Ball bearings	Roller bearings
Smooth, vibration-free	0,5	1	1	1,5	2	3	0,4	0,8
Normal	0,5	1	1	1,5	2	3,5	0,5	1
Pronounced shock loads¹⁾	≥ 1,5	≥ 2,5	≥ 1,5	≥ 3	≥ 2	≥ 4	≥ 1	≥ 2

For spherical roller thrust bearings, it is advisable to use $s_0 \geq 4$.

¹⁾ Where the magnitude of the shock load is not known, values of s_0 at least as large as those quoted above should be used. If the magnitude of the shock loads is known, smaller values of s_0 can be applied.

Calculation examples

Example 1: Basic rating life and SKF rating life

An SKF Explorer 6309 deep groove ball bearing is to operate at 3 000 r/min under a constant radial load $F_r = 10$ kN. Oil lubrication is to be used, the oil has an actual kinematic viscosity $\nu = 20$ mm²/s at normal operating temperature. The desired reliability is 90% and it is assumed that the operating conditions are very clean. What are the basic and SKF rating lives?

a) The basic rating life for 90% reliability is

$$L_{10} = \left(\frac{C}{P} \right)^3$$

From the product table for bearing 6309, $C = 55,3$ kN. Since the load is purely radial, $P = F_r = 10$ kN (→ *Equivalent dynamic bearing load*, page 85).

$$L_{10} = \left(\frac{55,3}{10} \right)^3$$

= 169 million revolutions

or in operating hours, using

$$L_{10h} = \frac{10^6}{60 n} L_{10}$$

$$L_{10h} = \frac{1\,000\,000}{60 \times 3\,000} \times 169$$

= 940 operating hours

b) The SKF rating life for 90% reliability is

$$L_{10m} = a_1 a_{SKF} L_{10}$$

- As a reliability of 90% is required, the L_{10m} life is to be calculated and $a_1 = 1$ (→ **table 1**, page 65).
- From the product table for bearing 6309, $d_m = 0,5 (d + D) = 0,5 (45 + 100) = 72,5$ mm

- From **diagram 5** (→ **page 72**), the rated oil viscosity at operating temperature for a speed of 3 000 r/min, $\nu_1 = 8,15$ mm²/s. Therefore, $\kappa = \nu/\nu_1 = 20/8,15 = 2,45$
- From the product table $P_u = 1,34$ kN and $P_u/P = 1,34/10 = 0,134$. As the conditions are very clean, $\eta_c = 0,8$ (→ **table 4**, page 74) and $\eta_c (P_u/P) = 0,107$. With $\kappa = 2,45$ and using the SKF Explorer scale in **diagram 1** (→ **page 66**), the value of $a_{SKF} = 8$ is obtained. Then, according to the SKF rating life equation

$$\begin{aligned} L_{10m} &= 1 \times 8 \times 169 \\ &= 1\,352 \text{ million revolutions} \end{aligned}$$

or in operating hours using

$$L_{10mh} = \frac{10^6}{60 n} L_{10m}$$

$$L_{10mh} = \frac{1\,000\,000}{60 \times 3\,000} \times 1\,352$$

= 7 512 operating hours

Example 2: Check contamination conditions

An existing application has to be reviewed. An SKF Explorer 6309-2RS1 deep groove ball bearing with integral seals and standard grease fill is working under the same conditions as described in example 1 ($\kappa = 2,45$). The contamination conditions of this application have to be checked to determine if it is possible to use a more cost-effective bearing for a minimum requisite life of 3 000 hours of operation.

- Considering grease lubrication and integral seals, the level of contamination can be characterized as high cleanliness and from **table 4** (→ **page 74**), $\eta_c = 0,8$. With $P_u/P = 0,134$, $\eta_c (P_u/P) = 0,107$, using the SKF Explorer scale in **diagram 1** (→ **page 66**) and $\kappa = 2,45$, $a_{SKF} = 8$.

$$L_{10mh} = 8 \times 940 = 7\,520 \text{ operating hours}$$



- A more cost-effective bearing arrangement would use a shielded SKF Explorer 6309-2Z bearing. The contamination level can be characterized as normal cleanliness, then from **table 4** (→ **page 74**) $\eta_c = 0,5$. With $P_u/P = 0,134$, $\eta_c (P_u/P) = 0,067$, using the SKF Explorer scale in **diagram 1** (→ **page 66**) and $\kappa = 2,45$, $a_{SKF} \approx 3,5$.

$L_{10mh} = 3,5 \times 940 = 3\ 290$ operating hours

Conclusion: This application would be able to take advantage of a more cost-effective solution by replacing the sealed bearing with a shielded bearing.

Example 3: Verify dynamic and static load conditions

The duty cycle of a sealed SKF Explorer spherical roller bearing 24026-2CS2/VT143 used in heavy transportation equipment of a steel plant has the operating conditions listed in the table below.

The static load of this application is determined with reasonable accuracy by taking into account the inertial loads that occur during loading and the shock loads that can occur if something is accidentally dropped.

It is required to verify the dynamic and static load conditions of this application, assuming a required L_{10mh} operating life of 60 000 hours and a minimum static safety factor of 1,5.

- From the product table and introductory text:

Load ratings:
 $C = 540\text{ kN}$; $C_0 = 815\text{ kN}$; $P_u = 81,5\text{ kN}$

Dimensions:
 $d = 130\text{ mm}$; $D = 200\text{ mm}$,
 therefore, $d_m = 0,5 (130 + 200) = 165\text{ mm}$

Grease fill
 Extreme pressure grease with a lithium thickener and mineral base oil, of NLGI consistency class 2, for a temperature range of -20 to $+110\text{ }^\circ\text{C}$ (-5 to $+230\text{ }^\circ\text{F}$) and a base oil viscosity at 40 and 100 $^\circ\text{C}$ (105 and $210\text{ }^\circ\text{F}$) of 200 and 16 mm^2/s , respectively.

- The following calculations are made or values determined:

1 $v_1 =$ rated viscosity, mm^2/s
 (→ **diagram 5, page 72**) – input: d_m and speed

2 $v =$ actual operating viscosity, mm^2/s
 (→ **diagram 6, page 73**) – input: lubricant viscosity at 40 $^\circ\text{C}$ ($105\text{ }^\circ\text{F}$) and operating temperature

3 $\kappa =$ viscosity ratio – calculated (v/v_1)

4 $\eta_c =$ factor for contamination level
 (→ **table 4, page 74**) – “High cleanliness”, sealed bearing: $\eta_c = 0,8$

Example 3/1

Operating conditions						
Duty interval	Equivalent dynamic load P	Time fraction U	Speed n	Temperature T		Equivalent static load P ₀
–	kN	–	r/min	$^\circ\text{C}$	$^\circ\text{F}$	kN
1	200	0,05	50	50	120	500
2	125	0,40	300	65	150	500
3	75	0,45	400	65	150	500
4	50	0,10	200	60	140	500

Selecting bearing size

- 5 L_{10h} = basic rating life according to the equation (→ **page 64**) – input: C, P and n
- 6 a_{SKF} = from **diagram 2** (→ **page 67**) – input: SKF Explorer bearing, η_c , P_u , P and κ
- 7 $L_{10mh1,2, \dots}$ = SKF rating life according to the equation (→ **page 65**) – input: a_{SKF} and $L_{10h1,2, \dots}$
- 8 L_{10mh} = SKF rating life according to the equation (→ **page 81**) – input: L_{10mh1} , L_{10mh2} , ... and U_1 , U_2 , ...

The SKF rating life of 84 300 hours exceeds the required operating life, therefore, the dynamic load conditions of the bearing are verified.

Finally, the static safety factor of this application is verified using

$$s_0 = \frac{C_0}{P_0} = \frac{815}{500} = 1,63$$

$$s_0 = 1,63 > s_{0 \text{ req}}$$

The above shows that the static safety of this application is verified. As the static load is determined accurately, the relatively small margin between the calculated and recommended static safety is of no concern.

SKF calculation tools

SKF possesses one of the most comprehensive and powerful sets of modelling and simulation packages in the bearing industry. They range from easy-to-use tools based on SKF catalogue *Rolling bearings* formulae to the most sophisticated calculation and simulation systems, running on parallel computers.

SKF has developed a range of programs to satisfy a number of customer requirements; from fairly simple design checks, through moderately complex investigations, to the most advanced simulations for bearing and machine design. Wherever possible, these programs are available for customers to use on their computers. Moreover, particular care is taken to provide integration and interoperability of the different systems with each other.

Calculation tools available online at skf.com/bearingcalculator

Easy-to-use tools for bearing selection and calculation are available online at skf.com/bearingcalculator. Bearing searches are available based on designation or dimensions, and simple bearing arrangements can be evaluated as well. The equations used are consistent with those used in this catalogue.

SKF's interactive engineering tools make it possible to generate drawings of bearings and housings that can be used in most commercially available CAD programs.

Example 3/2

Calculation values

Duty interval	Equivalent dynamic load P	Rated viscosity v_1	Operating viscosity v	κ^1	η_c	Basic rating life L_{10h}	a_{SKF}	SKF rating life L_{10mh}	Time fraction U	Resulting SKF rating life L_{10mh}
–	kN	mm ² /s	mm ² /s	–	–	h	–	h	–	h
1	200	120	120	1	0,8	9 136	1,2	11 050	0,05	84 300
2	125	25	60	2,3	0,8	7 295	7,8	57 260	0,40	
3	75	20	60	3	0,8	30 030	43	1 318 000	0,45	
4	50	36	75	2	0,8	232 040	50	11 600 000	0,10	

¹⁾ Grease with EP additives

SKF Bearing Beacon

SKF Bearing Beacon is the mainstream bearing application program used by SKF engineers to find the best solution for customers' bearing systems. Working in a virtual environment, SKF engineers combine mechanical systems containing shafts, gears and housings with a precise bearing model for an in-depth analysis of the system's behaviour. The program can also analyze rolling fatigue in a bearing using the SKF rating life method. SKF Bearing Beacon is the result of years of research and development within SKF.

Orpheus

The numerical tool Orpheus is used to study and optimize the dynamic behaviour of noise and vibration-critical bearing applications, such as electric motors, gearboxes. The program is also used to solve complete non-linear equations of motion for a bearing arrangement and the surrounding components, such as gears, shafts and housings.

Orpheus can provide a profound understanding of the dynamic behaviour of an application, including the bearings, accounting for form deviations (waviness) and misalignment. This enables SKF engineers to determine the most suitable bearing type and size as well as the corresponding mounting and preload conditions for a given application.

Beast

Beast is a simulation program that enables SKF engineers to simulate the detailed dynamics inside a bearing. It can be seen as a virtual test rig performing detailed studies of forces, moments etc. inside a bearing under virtually any load condition. This enables the "testing" of new concepts and designs in a shorter time and with more information gained compared with traditional physical testing.

Other programs

In addition to the above-mentioned programs, SKF has developed dedicated computer programs that enable SKF scientists to provide customers with bearings having an optimized bearing surface finish to extend bearing service life under severe operating conditions. These programs can calculate the lubricant film thickness in elasto-hydrodynamically lubricated contacts. In addition, the local film thickness resulting from the deformation of the three dimensional surface topography inside such contacts is calculated in detail and the consequent reduction of bearing fatigue life.

SKF engineers also use commercial packages to perform, for example, finite element or generic system dynamics analyses. These tools are integrated with the SKF proprietary systems enabling a faster and more robust connection with customer data and models.

B

SKF Engineering Consultancy Services

The basic information required to calculate and design a bearing arrangement can be found in this catalogue. But there are applications where it is desirable to predict the expected bearing life as accurately as possible, either because sufficient experience with similar bearing arrangements is lacking, or because economy and/or operational reliability are of extreme importance. In these cases, for example, it is advisable to consult SKF Engineering Consultancy Services. They provide calculations and simulations utilizing high-tech computer programs, in combination with one hundred years of accumulated experience in the field of rotating machine components.

They can provide support with the complete SKF application know-how. The SKF application engineering specialists can support with the following services:

- analyse technical problems
- suggest appropriate system solutions
- select the appropriate lubricant and lubrication method and an optimized maintenance programme

SKF Engineering Consultancy Services provides a new approach to services concerning machines and installations for OEMs and end-users. Some of these service benefits are:

- faster development processes and reduced time to market
- reduced implementation costs by virtual testing before production starts
- improved bearing arrangement by reducing noise and vibration levels
- higher power density by upgrading
- extended service life by improving the lubrication or sealing system

Advanced computer programs

Within the SKF Engineering Consultancy Services, there are highly advanced computer programs which can be used for the following:

- analytical modelling of complete bearing arrangements, consisting of shaft, housing, gears, couplings, etc.
- static analysis to determine the elastic deformations and stresses in components of mechanical systems
- dynamic analysis to determine the vibration behaviour of systems under working conditions ("virtual testing")
- visual and animated presentation of structural and component deflection
- optimizing system costs, service life, vibration and noise levels

The standard computer programs used within the SKF Engineering Consultancy Services for calculations and simulations are described briefly under *SKF calculation tools* (→ **page 92**).

For additional information about the SKF Engineering Consultancy Services, contact your local SKF representative.

SKF life testing

SKF endurance testing activities are concentrated at the SKF Engineering & Research Centre in the Netherlands. The test facilities are unique in the bearing industry with regard to sophistication and the number of test rigs and are ISO 17025 accredited. The centre also supports work carried out at the research facilities of the major SKF manufacturing facilities.

SKF undertakes life testing, mainly to be able to continuously improve the design, the materials and the manufacturing processes of bearing products. Furthermore it is also essential to develop and continuously improve the engineering models required for the design of bearing applications.

Typical endurance testing activities include tests on bearing population samples under:

- full-film lubrication conditions
- reduced lubricant film conditions
- predefined contamination conditions of the lubricant

SKF also undertakes life tests to:

- verify the performance commitments made in product catalogues
- audit the quality of the SKF standard bearing production
- research the influences of lubricants and lubricating conditions on bearing life
- support the development of theories for rolling contact fatigue
- compare with competitive products

The powerful and firmly controlled life tests combined with post-test investigations with state-of-the-art equipment make it possible to investigate the factors that affect the life of the bearings in a systematic way.

High performance SKF Explorer and SKF Energy Efficient (E2) bearings are examples of the implementation of the optimized influencing factors on the basis of analytical simulation models and experimental verification at the component and complete bearing level.



B

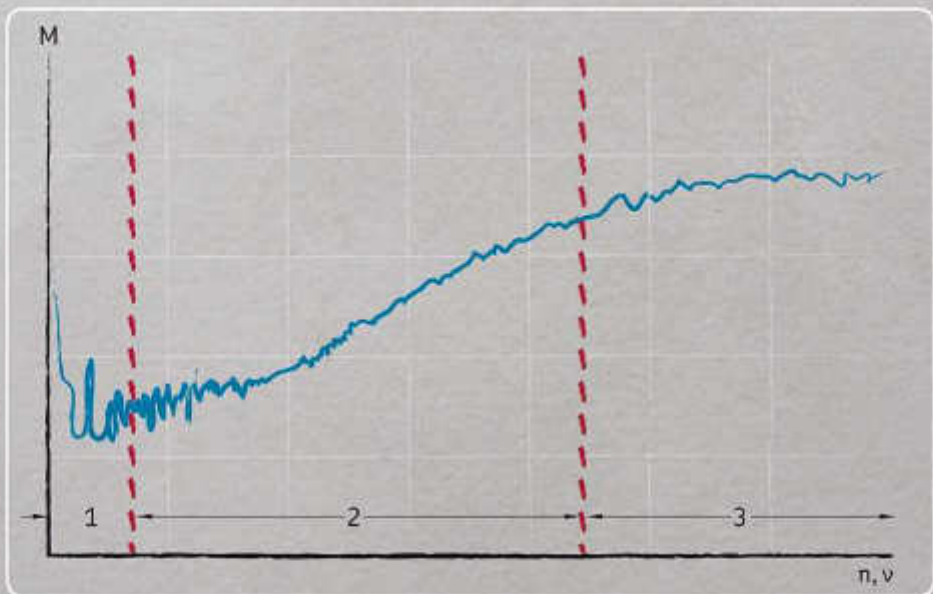

Friction

Estimating the frictional moment	98
The SKF model for calculating the frictional moment	99
Rolling frictional moment.	100
Inlet shear heating reduction factor . .	101
Kinematic replenishment/starvation reduction factor	102
Sliding frictional moment.	103
Effect of lubrication on sliding friction.	103
Frictional moment of seals.	109
Drag losses.	110
Drag losses in oil bath lubrication	110
Drag losses for oil jet lubrication	112
Additional effects on the frictional moment.	113
Effects of clearance and misalignment on friction	113
Effects of grease fill on friction	113
Additional information for specific bearing types and performance classes.	113
Hybrid bearings	113
SKF Energy Efficient bearings	113
Y-bearings (insert bearings).	113
Needle roller bearings	113
Starting torque.	114
Power loss and bearing temperature	114



Friction

The friction in a rolling bearing determines the amount of heat generated by the bearing. The amount of friction depends on the loads and several other factors, including:

- bearing type and size
- operating speed
- properties and quantity of the lubricant

The total resistance to rotation in a bearing is the result of rolling and sliding friction in the contact areas, between the rolling elements and raceways, between the rolling elements and cage, and between the rolling elements and other guiding surfaces. Friction is also generated by lubricant drag and contact seals, if applicable.

Estimating the frictional moment

Under certain conditions, the frictional moment can be estimated with sufficient accuracy using a constant coefficient of friction μ . The conditions are:

- bearing load $P \approx 0,1 C$
- good lubrication
- normal operating conditions

The frictional moment under these conditions can be estimated using

$$M = 0,5 \mu P d$$

For radial needle roller bearings, use F or F_w instead of d .

where

M = frictional moment [Nmm]

μ = constant coefficient of friction for the bearing (→ **table 1**)

P = equivalent dynamic bearing load [N]

d = bearing bore diameter [mm]

F = inner ring raceway diameter [mm]

F_w = diameter under the rollers [mm]

Table 1

Constant coefficient of friction μ for open bearings
(bearings without contact seals)

Bearing type	Coefficient of friction μ
Deep groove ball bearings	0,0015
Angular contact ball bearings	
– single row	0,0020
– double row	0,0024
– four-point contact	0,0024
Self-aligning ball bearings	0,0010
Cylindrical roller bearings	
– with a cage, when $F_a = 0$	0,0011
– full complement, when $F_a = 0$	0,0020
Needle roller bearings with a cage	0,0020
Tapered roller bearings	0,0018
Spherical roller bearings	0,0018
CARB toroidal roller bearings with a cage	0,0016
Thrust ball bearings	0,0013
Cylindrical roller thrust bearings	0,0050
Needle roller thrust bearings	0,0050
Spherical roller thrust bearings	0,0018

The SKF model for calculating the frictional moment

A sketch of the frictional moment in a typical bearing, as a function of rotational speed or viscosity, is presented in **diagram 1**. During the start-up period (zone 1), as speed or viscosity increases, the frictional moment decreases as a hydrodynamic (lubricant) film is being formed. As speeds or viscosity continue to increase and the bearing enters into the full elasto-hydrodynamic lubrication (EHL) zone, the thickness of the hydrodynamic film increases (increasing κ value, **page 241**), which also increases friction (zone 2). Eventually, speed or viscosity increase to the point where kinematic starvation and inlet shear cause friction to reach a plateau or even decrease (zone 3).

For additional information, refer to *Inlet shear heating reduction factor* (→ **page 101**) and *Kinematic replenishment/starvation reduction factor* (→ **page 102**).

To accurately calculate the total frictional moment in a rolling bearing, the following sources and their tribological effects must be taken into account:

- the rolling frictional moment and eventual effects of high-speed starvation and inlet shear heating
- the sliding frictional moment and its effect on the quality of the lubrication
- the frictional moment from seal(s)
- the frictional moment from drag losses, churning, splashing etc.

The SKF model for calculating the frictional moment closely follows the real behaviour of the bearing as it considers all contact areas, design changes and improvements made to SKF bearings as well as internal and external influences.



Diagram 1

Bearing frictional moment as a function of speed or viscosity

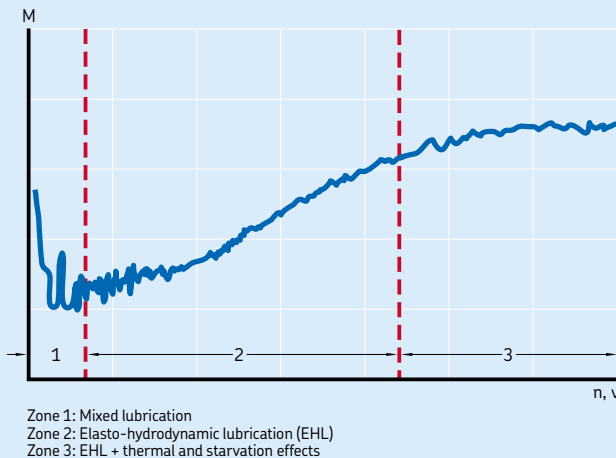

Friction

The SKF model for calculating the frictional moment uses

$$M = M_{rr} + M_{sl} + M_{seal} + M_{drag}$$

where

M = total frictional moment

M_{rr} = rolling frictional moment

M_{sl} = sliding frictional moment (→ page 103)

M_{seal} = frictional moment of seals (→ page 109)

M_{drag} = frictional moment of drag losses, churning, splashing etc. (→ page 110)

The SKF model is derived from more advanced computational models developed by SKF. It is designed to provide approximate reference values under the following application conditions:

- grease lubrication:
 - only steady state conditions (after several hours of operation)
 - lithium soap grease with mineral oil
 - bearing free volume filled approximately 30%
 - ambient temperature 20 °C (70 °F) or higher
- oil lubrication:
 - oil bath, oil-air or oil jet
 - viscosity range from 2 to 500 mm²/s
- loads equal to or larger than the recommended minimum load and at least:
 - 0,01 C for ball bearings
 - 0,02 C for roller bearings
- constant loads in magnitude and direction
- normal operating clearance
- constant speed but not higher than the permissible speed

For paired bearings, the frictional moment can be calculated separately for each bearing and added together. The radial load is divided equally over the two bearings; the axial load is shared according to the bearing arrangement.

Rolling frictional moment

The rolling frictional moment can be calculated using

$$M_{rr} = \phi_{ish} \phi_{rs} G_{rr} (v n)^{0,6}$$

where

M_{rr} = rolling frictional moment [Nmm]

ϕ_{ish} = inlet shear heating reduction factor

ϕ_{rs} = kinematic replenishment/starvation reduction factor (→ page 102)

G_{rr} = variable (→ table 2, page 104), depending on:

- the bearing type
- the bearing mean diameter d_m [mm]
= 0,5 (d + D)
- the radial load F_r [N]
- the axial load F_a [N]

n = rotational speed [r/min]

v = actual operating viscosity of the oil or the base oil of the grease [mm²/s]

NOTE: The formulae provided in this section lead to rather complex calculations. Therefore, SKF strongly recommends calculating the frictional moment using the tools available online at skf.com/bearingcalculator.

Inlet shear heating reduction factor

Compared with the quantity of lubricant available in the bearing, not all of it can go through the contact area. Only a tiny amount of lubricant is used to form a hydrodynamic film. Therefore, some of the oil close to the contact area inlet is rejected and produces a reverse flow (→ **fig. 1**). This reverse flow shears the lubricant, generating heat, which lowers the oil viscosity and reduces the film thickness and rolling friction.

For the effect described above, the inlet shear heating reduction factor can be estimated using

$$\Phi_{ish} = \frac{1}{1 + 1,84 \times 10^{-9} (n d_m)^{1,28} v^{0,64}}$$

where

Φ_{ish} = inlet shear heating reduction factor
(→ **diagram 2**)

n = rotational speed [r/min]

d_m = bearing mean diameter [mm]
= 0,5 (d + D)

v = actual operating viscosity of the oil or the base oil of the grease [mm²/s]

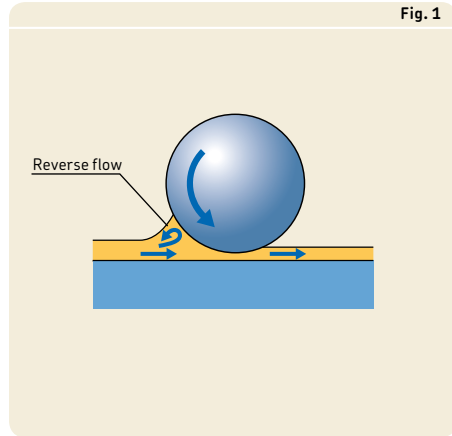
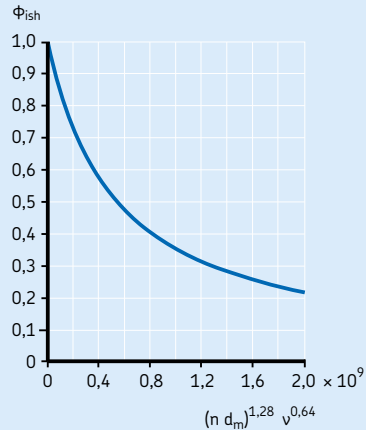

Diagram 2

Inlet shear heating reduction factor Φ_{ish}



Friction

Kinematic replenishment/starvation reduction factor

For oil-air, oil jet, low level oil bath lubrication (i.e. oil level H lower than the centre of the lowest rolling element) and grease lubrication methods, continuous over-rolling displaces excess lubricant from the raceways. In applications where viscosity or speeds are high, the lubricant may not have sufficient time to replenish the raceways, causing a “kinematic starvation” effect. Kinematic starvation reduces the thickness of the hydrodynamic film (decreasing κ value, **page 241**) and rolling friction.

For the type of lubrication methods described above, the kinematic replenishment/starvation reduction factor can be estimated using

$$\Phi_{rs} = \frac{1}{e^{\left[K_{rs} \cdot v \cdot n \cdot (d + D) \cdot \sqrt{\frac{K_z}{2(D-d)}} \right]}}$$

where

Φ_{rs} = kinematic replenishment/starvation reduction factor

e = base of natural logarithm $\approx 2,718$

K_{rs} = replenishment/starvation constant:

- for low level oil bath and oil jet lubrication $\rightarrow 3 \times 10^{-8}$
- for grease and oil-air lubrication $\rightarrow 6 \times 10^{-8}$

K_z = bearing type related geometric constant (\rightarrow **table 5, page 112**)

v = actual operating viscosity of the oil or the base oil of the grease [mm^2/s]

n = rotational speed [r/min]

d = bearing bore diameter [mm]

D = bearing outside diameter [mm]

Sliding frictional moment

The sliding frictional moment can be calculated using

$$M_{sl} = G_{sl} \mu_{sl}$$

where

M_{sl} = sliding frictional moment [Nmm]

G_{sl} = variable (→ **table 2, page 104**),

depending on:

- the bearing type
- the bearing mean diameter d_m [mm]
= $0,5 (d + D)$
- the radial load F_r [N]
- the axial load F_a [N]

μ_{sl} = sliding friction coefficient

Effect of lubrication on sliding friction

The sliding friction coefficient for full-film and mixed lubrication conditions can be estimated using

$$\mu_{sl} = \phi_{bl} \mu_{bl} + (1 - \phi_{bl}) \mu_{EHL}$$

where

μ_{sl} = sliding friction coefficient

ϕ_{bl} = weighting factor for the sliding friction coefficient

$$= \frac{1}{e^{2,6 \times 10^{-8} (n \nu)^{1,4} d_m}}$$

(→ **diagram 3**)

e = base of natural logarithm $\approx 2,718$

n = rotational speed [r/min]

ν = actual operating viscosity of the oil or the base oil of the grease [mm^2/s]

d_m = bearing mean diameter [mm]
= $0,5 (d + D)$

μ_{bl} = coefficient depending on the additive package in the lubricant, generally $\approx 0,15$

μ_{EHL} = sliding friction coefficient in full-film conditions

Values for μ_{EHL} are:

- 0,02 for cylindrical roller bearings
 - 0,002 for tapered roller bearings
- Other bearings
- 0,05 for lubrication with mineral oils
 - 0,04 for lubrication with synthetic oils
 - 0,1 for lubrication with transmission fluids

Diagram 3 shows the influence of lubrication conditions on the weighting factor for the sliding friction coefficient:

- For full-film lubrication (corresponding to large values of κ , **page 241**), the value of the weighting factor for the sliding friction coefficient ϕ_{bl} tends to zero.
- For mixed lubrication, which can occur when lubricant viscosity or the bearing speed is low, the value of the weighting factor for the sliding friction coefficient ϕ_{bl} tends to 1, as occasional metal-to-metal contact may occur and friction increases.



Diagram 3

Weighting factor ϕ_{bl} for the sliding friction coefficient

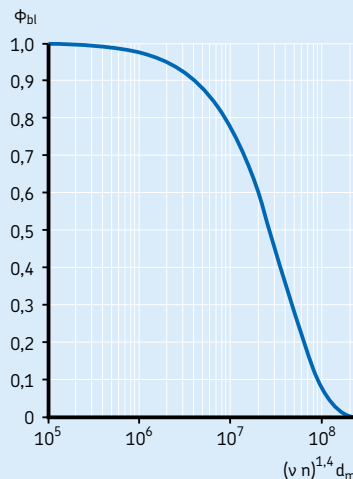

Table 2a

Geometric and load dependent variables for rolling and sliding frictional moments – radial bearings

Bearing type	Rolling frictional variable G_{rr}	Sliding frictional variable G_{sl}
Deep groove ball bearings	when $F_a = 0$ $G_{rr} = R_1 d_m^{1,96} F_r^{0,54}$	when $F_a = 0$ $G_{sl} = S_1 d_m^{-0,26} F_r^{5/3}$
	when $F_a > 0$ $G_{rr} = R_1 d_m^{1,96} \left(F_r + \frac{R_2}{\sin \alpha_F} F_a \right)^{0,54}$	when $F_a > 0$ $G_{sl} = S_1 d_m^{-0,145} \left(F_r^{0,5} + \frac{S_2 d_m^{1,5}}{\sin \alpha_F} F_a^{1,5} \right)^{1/3}$
	$\alpha_F = 24,6 (F_a/C_0)^{0,24} [^\circ]$	
Angular contact ball bearings ¹⁾	$G_{rr} = R_1 d_m^{1,97} [F_r + F_g + R_2 F_a]^{0,54}$ $F_g = R_3 d_m^4 n^2$	$G_{sl} = S_1 d_m^{0,26} [(F_r + F_g)^{4/3} + S_2 F_a^{4/3}]$ $F_g = S_3 d_m^4 n^2$
Four-point contact ball bearings	$G_{rr} = R_1 d_m^{1,97} [F_r + F_g + R_2 F_a]^{0,54}$ $F_g = R_3 d_m^4 n^2$	$G_{sl} = S_1 d_m^{0,26} [(F_r + F_g)^{4/3} + S_2 F_a^{4/3}]$ $F_g = S_3 d_m^4 n^2$
Self-aligning ball bearings	$G_{rr} = R_1 d_m^2 [F_r + F_g + R_2 F_a]^{0,54}$ $F_g = R_3 d_m^{3,5} n^2$	$G_{sl} = S_1 d_m^{-0,12} [(F_r + F_g)^{4/3} + S_2 F_a^{4/3}]$ $F_g = S_3 d_m^{3,5} n^2$
Cylindrical roller bearings	$G_{rr} = R_1 d_m^{2,41} F_r^{0,31}$	$G_{sl} = S_1 d_m^{0,9} F_a + S_2 d_m F_r$
Tapered roller bearings ¹⁾	$G_{rr} = R_1 d_m^{2,38} (F_r + R_2 Y F_a)^{0,31}$	$G_{sl} = S_1 d_m^{0,82} (F_r + S_2 Y F_a)$
For the axial load factor Y for single row bearings → product tables		
Spherical roller bearings	$G_{rr,e} = R_1 d_m^{1,85} (F_r + R_2 F_a)^{0,54}$	$G_{sl,e} = S_1 d_m^{0,25} (F_r^4 + S_2 F_a^4)^{1/3}$
	$G_{rr,l} = R_3 d_m^{2,3} (F_r + R_4 F_a)^{0,31}$	$G_{sl,l} = S_3 d_m^{0,94} (F_r^3 + S_4 F_a^3)^{1/3}$
	when $G_{rr,e} < G_{rr,l}$	when $G_{sl,e} < G_{sl,l}$
	$G_{rr} = G_{rr,e}$	$G_{sl} = G_{sl,e}$
	otherwise	otherwise
	$G_{rr} = G_{rr,l}$	$G_{sl} = G_{sl,l}$
CARB toroidal roller bearings	when $F_r < (R_2^{1,85} d_m^{0,78}/R_1^{1,85})^{2,35}$ $G_{rr} = R_1 d_m^{1,97} F_r^{0,54}$ otherwise	when $F_r < (S_2 d_m^{1,24}/S_1)^{1,5}$ $G_{sl} = S_1 d_m^{-0,19} F_r^{5/3}$ otherwise
	$G_{rr} = R_2 d_m^{2,37} F_r^{0,31}$	$G_{sl} = S_2 d_m^{1,05} F_r$

The geometry constants R and S are listed in **table 3**, starting on **page 105**.

Both loads, F_r and F_a are always considered as positive.

¹⁾ The value to be used for F_a is the external axial load.

Table 2b

Geometric and load dependent variables for rolling and sliding frictional moments – thrust bearings		
Bearing type	Rolling frictional variable G_{rr}	Sliding frictional variable G_{sl}
Thrust ball bearings	$G_{rr} = R_1 d_m^{1,83} F_a^{0,54}$	$G_{sl} = S_1 d_m^{0,05} F_a^{4/3}$
Cylindrical roller thrust bearings	$G_{rr} = R_1 d_m^{2,38} F_a^{0,31}$	$G_{sl} = S_1 d_m^{0,62} F_a$
Spherical roller thrust bearings	$G_{rr,e} = R_1 d_m^{1,96} (F_r + R_2 F_a)^{0,54}$ $G_{rr,l} = R_3 d_m^{2,39} (F_r + R_4 F_a)^{0,31}$ when $G_{rr,e} < G_{rr,l}$ $G_{rr} = G_{rr,e}$ otherwise $G_{rr} = G_{rr,l}$	$G_{sl,e} = S_1 d_m^{-0,35} (F_r^{5/3} + S_2 F_a^{5/3})$ $G_{sl,l} = S_3 d_m^{0,89} (F_r + F_a)$ when $G_{sl,e} < G_{sl,l}$ $G_{sr} = G_{sl,e}$ otherwise $G_{sr} = G_{sl,l}$ $G_f = S_4 d_m^{0,76} (F_r + S_5 F_a)$ $G_{sl} = G_{sr} + \frac{G_f}{e^{10^{-6}} (n v)^{1,4} d_m}$



Table 3

Geometric constants for rolling and sliding frictional moments						
Bearing type	Geometric constants for rolling frictional moments			sliding frictional moments		
	R_1	R_2	R_3	S_1	S_2	S_3
Deep groove ball bearings	→ table 3a)			→ table 3a)		
Angular contact ball bearings						
– single row	$5,03 \times 10^{-7}$	1,97	$1,90 \times 10^{-12}$	$1,30 \times 10^{-2}$	0,68	$1,91 \times 10^{-12}$
– double row	$6,34 \times 10^{-7}$	1,41	$7,83 \times 10^{-13}$	$7,56 \times 10^{-3}$	1,21	$7,83 \times 10^{-13}$
– four-point contact	$4,78 \times 10^{-7}$	2,42	$1,40 \times 10^{-12}$	$1,20 \times 10^{-2}$	0,9	$1,40 \times 10^{-12}$
Self-aligning ball bearings	→ table 3b)			→ table 3b)		
Cylindrical roller bearings	→ table 3c)			→ table 3c)		
Tapered roller bearings	→ table 3d)			→ table 3d)		
Spherical roller bearings	→ table 3e)			→ table 3e)		
CARB toroidal roller bearings	→ table 3f)			→ table 3f)		
Thrust ball bearings	$1,03 \times 10^{-6}$			$1,6 \times 10^{-2}$		
Cylindrical roller thrust bearings	$2,25 \times 10^{-6}$			0,154		
Spherical roller thrust bearings	→ table 3g)			→ table 3g)		

Table 3a

Geometric constants for rolling and sliding frictional moments of deep groove ball bearings

Bearing series	Geometric constants for rolling frictional moments		sliding frictional moments	
	R_1	R_2	S_1	S_2
2, 3	$4,4 \times 10^{-7}$	1,7	$2,00 \times 10^{-3}$	100
42, 43	$5,4 \times 10^{-7}$	0,96	$3,00 \times 10^{-3}$	40
60, 630	$4,1 \times 10^{-7}$	1,7	$3,73 \times 10^{-3}$	14,6
62, 622	$3,9 \times 10^{-7}$	1,7	$3,23 \times 10^{-3}$	36,5
63, 623	$3,7 \times 10^{-7}$	1,7	$2,84 \times 10^{-3}$	92,8
64	$3,6 \times 10^{-7}$	1,7	$2,43 \times 10^{-3}$	198
160, 161	$4,3 \times 10^{-7}$	1,7	$4,63 \times 10^{-3}$	4,25
617, 618, 628, 637, 638	$4,7 \times 10^{-7}$	1,7	$6,50 \times 10^{-3}$	0,78
619, 639	$4,3 \times 10^{-7}$	1,7	$4,75 \times 10^{-3}$	3,6

Table 3b

Geometric constants for rolling and sliding frictional moments of self-aligning ball bearings

Bearing series	Geometric constants for rolling frictional moments			sliding frictional moments		
	R_1	R_2	R_3	S_1	S_2	S_3
12	$3,25 \times 10^{-7}$	6,51	$2,43 \times 10^{-12}$	$4,36 \times 10^{-3}$	9,33	$2,43 \times 10^{-12}$
13	$3,11 \times 10^{-7}$	5,76	$3,52 \times 10^{-12}$	$5,76 \times 10^{-3}$	8,03	$3,52 \times 10^{-12}$
22	$3,13 \times 10^{-7}$	5,54	$3,12 \times 10^{-12}$	$5,84 \times 10^{-3}$	6,60	$3,12 \times 10^{-12}$
23	$3,11 \times 10^{-7}$	3,87	$5,41 \times 10^{-12}$	0,01	4,35	$5,41 \times 10^{-12}$
112	$3,25 \times 10^{-7}$	6,16	$2,48 \times 10^{-12}$	$4,33 \times 10^{-3}$	8,44	$2,48 \times 10^{-12}$
130	$2,39 \times 10^{-7}$	5,81	$1,10 \times 10^{-12}$	$7,25 \times 10^{-3}$	7,98	$1,10 \times 10^{-12}$
139	$2,44 \times 10^{-7}$	7,96	$5,63 \times 10^{-13}$	$4,51 \times 10^{-3}$	12,11	$5,63 \times 10^{-13}$

Table 3c

Geometric constants for rolling and sliding frictional moments of cylindrical roller bearings

Bearing series	Geometric constants for rolling frictional moments		sliding frictional moments	
	R_1		S_1	S_2
Bearing with cage of the N, NU, NJ or NUP design				
2, 3	$1,09 \times 10^{-6}$		0,16	0,0015
4	$1,00 \times 10^{-6}$		0,16	0,0015
10	$1,12 \times 10^{-6}$		0,17	0,0015
12, 20	$1,23 \times 10^{-6}$		0,16	0,0015
22	$1,40 \times 10^{-6}$		0,16	0,0015
23	$1,48 \times 10^{-6}$		0,16	0,0015
High capacity bearings with cage of the NCF .. ECJB, RN .. ECJB, NJF .. ECJA, RNU .. ECJA or NUH .. ECMH design				
22	$1,54 \times 10^{-6}$		0,16	0,0015
23	$1,63 \times 10^{-6}$		0,16	0,0015
Full complement bearings of the NCF, NJG, NNCL, NNCF, NNC or NNF design				
All series	$2,13 \times 10^{-6}$		0,16	0,0015

Table 3d

Geometric constants for rolling and sliding frictional moments of tapered roller bearings

Bearing series	Geometric constants for rolling frictional moments		sliding frictional moments	
	R_1	R_2	S_1	S_2
302	$1,76 \times 10^{-6}$	10,9	0,017	2
303	$1,69 \times 10^{-6}$	10,9	0,017	2
313 (X)	$1,84 \times 10^{-6}$	10,9	0,048	2
320 X	$2,38 \times 10^{-6}$	10,9	0,014	2
322	$2,27 \times 10^{-6}$	10,9	0,018	2
322 B	$2,38 \times 10^{-6}$	10,9	0,026	2
323	$2,38 \times 10^{-6}$	10,9	0,019	2
323 B	$2,79 \times 10^{-6}$	10,9	0,030	2
329	$2,31 \times 10^{-6}$	10,9	0,009	2
330	$2,71 \times 10^{-6}$	11,3	0,010	2
331	$2,71 \times 10^{-6}$	10,9	0,015	2
332	$2,71 \times 10^{-6}$	10,9	0,018	2
LL	$1,72 \times 10^{-6}$	10,9	0,0057	2
L	$2,19 \times 10^{-6}$	10,9	0,0093	2
LM	$2,25 \times 10^{-6}$	10,9	0,011	2
M	$2,48 \times 10^{-6}$	10,9	0,015	2
HM	$2,60 \times 10^{-6}$	10,9	0,020	2
H	$2,66 \times 10^{-6}$	10,9	0,025	2
HH	$2,51 \times 10^{-6}$	10,9	0,027	2
All other	$2,31 \times 10^{-6}$	10,9	0,019	2

Table 3e

Geometric constants for rolling and sliding frictional moments of spherical roller bearings

Bearing series	Geometric constants for rolling frictional moments				sliding frictional moments			
	R ₁	R ₂	R ₃	R ₄	S ₁	S ₂	S ₃	S ₄
213 E, 222 E	1,6 × 10 ⁻⁶	5,84	2,81 × 10 ⁻⁶	5,8	3,62 × 10 ⁻³	508	8,8 × 10 ⁻³	117
222	2,0 × 10 ⁻⁶	5,54	2,92 × 10 ⁻⁶	5,5	5,10 × 10 ⁻³	414	9,7 × 10 ⁻³	100
223	1,7 × 10 ⁻⁶	4,1	3,13 × 10 ⁻⁶	4,05	6,92 × 10 ⁻³	124	1,7 × 10 ⁻²	41
223 E	1,6 × 10 ⁻⁶	4,1	3,14 × 10 ⁻⁶	4,05	6,23 × 10 ⁻³	124	1,7 × 10 ⁻²	41
230	2,4 × 10 ⁻⁶	6,44	3,76 × 10 ⁻⁶	6,4	4,13 × 10 ⁻³	755	1,1 × 10 ⁻²	160
231	2,4 × 10 ⁻⁶	4,7	4,04 × 10 ⁻⁶	4,72	6,70 × 10 ⁻³	231	1,7 × 10 ⁻²	65
232	2,3 × 10 ⁻⁶	4,1	4,00 × 10 ⁻⁶	4,05	8,66 × 10 ⁻³	126	2,1 × 10 ⁻²	41
238	3,1 × 10 ⁻⁶	12,1	3,82 × 10 ⁻⁶	12	1,74 × 10 ⁻³	9 495	5,9 × 10 ⁻³	1 057
239	2,7 × 10 ⁻⁶	8,53	3,87 × 10 ⁻⁶	8,47	2,77 × 10 ⁻³	2 330	8,5 × 10 ⁻³	371
240	2,9 × 10 ⁻⁶	4,87	4,78 × 10 ⁻⁶	4,84	6,95 × 10 ⁻³	240	2,1 × 10 ⁻²	68
241	2,6 × 10 ⁻⁶	3,8	4,79 × 10 ⁻⁶	3,7	1,00 × 10 ⁻²	86,7	2,9 × 10 ⁻²	31
248	3,8 × 10 ⁻⁶	9,4	5,09 × 10 ⁻⁶	9,3	2,80 × 10 ⁻³	3 415	1,2 × 10 ⁻²	486
249	3,0 × 10 ⁻⁶	6,67	5,09 × 10 ⁻⁶	6,62	3,90 × 10 ⁻³	887	1,7 × 10 ⁻²	180

Table 3f

Geometric constants for rolling and sliding frictional moments of CARB toroidal roller bearings with a cage

Bearing series	Geometric constants for rolling frictional moments		sliding frictional moments	
	R ₁	R ₂	S ₁	S ₂
C 22	1,17 × 10 ⁻⁶	2,08 × 10 ⁻⁶	1,32 × 10 ⁻³	0,8 × 10 ⁻²
C 23	1,20 × 10 ⁻⁶	2,28 × 10 ⁻⁶	1,24 × 10 ⁻³	0,9 × 10 ⁻²
C 30	1,40 × 10 ⁻⁶	2,59 × 10 ⁻⁶	1,58 × 10 ⁻³	1,0 × 10 ⁻²
C 31	1,37 × 10 ⁻⁶	2,77 × 10 ⁻⁶	1,30 × 10 ⁻³	1,1 × 10 ⁻²
C 32	1,33 × 10 ⁻⁶	2,63 × 10 ⁻⁶	1,31 × 10 ⁻³	1,1 × 10 ⁻²
C 39	1,45 × 10 ⁻⁶	2,55 × 10 ⁻⁶	1,84 × 10 ⁻³	1,0 × 10 ⁻²
C 40	1,53 × 10 ⁻⁶	3,15 × 10 ⁻⁶	1,50 × 10 ⁻³	1,3 × 10 ⁻²
C 41	1,49 × 10 ⁻⁶	3,11 × 10 ⁻⁶	1,32 × 10 ⁻³	1,3 × 10 ⁻²
C 49	1,49 × 10 ⁻⁶	3,24 × 10 ⁻⁶	1,39 × 10 ⁻³	1,5 × 10 ⁻²
C 59	1,77 × 10 ⁻⁶	3,81 × 10 ⁻⁶	1,80 × 10 ⁻³	1,8 × 10 ⁻²
C 60	1,83 × 10 ⁻⁶	5,22 × 10 ⁻⁶	1,17 × 10 ⁻³	2,8 × 10 ⁻²
C 69	1,85 × 10 ⁻⁶	4,53 × 10 ⁻⁶	1,61 × 10 ⁻³	2,3 × 10 ⁻²

Table 3g

Geometric constants for rolling and sliding frictional moments of spherical roller thrust bearings

Bearing series	Geometric constants for rolling frictional moments				sliding frictional moments				
	R ₁	R ₂	R ₃	R ₄	S ₁	S ₂	S ₃	S ₄	S ₅
292	1,32 × 10 ⁻⁶	1,57	1,97 × 10 ⁻⁶	3,21	4,53 × 10 ⁻³	0,26	0,02	0,1	0,6
292 E	1,32 × 10 ⁻⁶	1,65	2,09 × 10 ⁻⁶	2,92	5,98 × 10 ⁻³	0,23	0,03	0,17	0,56
293	1,39 × 10 ⁻⁶	1,66	1,96 × 10 ⁻⁶	3,23	5,52 × 10 ⁻³	0,25	0,02	0,1	0,6
293 E	1,16 × 10 ⁻⁶	1,64	2,00 × 10 ⁻⁶	3,04	4,26 × 10 ⁻³	0,23	0,025	0,15	0,58
294 E	1,25 × 10 ⁻⁶	1,67	2,15 × 10 ⁻⁶	2,86	6,42 × 10 ⁻³	0,21	0,04	0,2	0,54

Frictional moment of seals

Where bearings are fitted with contact seals, the frictional losses from the seals may exceed those generated by the bearing. The frictional moment of seals for bearings that are sealed on both sides can be estimated using

$$M_{\text{seal}} = K_{S1} d_s^\beta + K_{S2}$$

where

M_{seal} = frictional moment of seals [Nmm]

K_{S1} = constant (→ **table 4**), depending on:

- the seal type
- the bearing type and size

d_s = seal counterface diameter [mm] (→ **table 4**)

β = exponent (→ **table 4**), depending on:

- the seal type
- the bearing type

K_{S2} = constant (→ **table 4**), depending on:

- the seal type
- the bearing type and size

In cases where there is only one seal, the friction generated is 0,5 M_{seal} .

For deep groove ball bearings with RSL seals and $D > 25$ mm, use the calculated value of M_{seal} , irrespective whether there is one or two seals.



Table 4

Seal frictional moment: Exponent and constants

Seal type Bearing type	Bearing outside diameter [mm]		Exponent and constants			Seal counterface diameter $d_s^{1)}$
	D over	incl.	β	K_{S1}	K_{S2}	
RSL seals						
Deep groove ball bearings	–	25	0	0	0	d_2
	25	52	2,25	0,0018	0	d_2
RZ seals						
Deep groove ball bearings	–	175	0	0	0	d_1
RSH seals						
Deep groove ball bearings	–	52	2,25	0,028	2	d_2
RS1 seals						
Deep groove ball bearings	–	62	2,25	0,023	2	d_1, d_2
	62	80	2,25	0,018	20	d_1, d_2
	80	100	2,25	0,018	15	d_1, d_2
	100		2,25	0,018	0	d_1, d_2
Angular contact ball bearings	30	120	2	0,014	10	d_1
Self-aligning ball bearings	30	125	2	0,014	10	d_2
LS seals						
Cylindrical roller bearings	42	360	2	0,032	50	E
CS, CS2 and CS5 seals						
Spherical roller bearings	62	300	2	0,057	50	d_2
CARB toroidal roller bearings	42	340	2	0,057	50	d_2

¹⁾ Designation of the dimension listed in the product tables

Friction

Drag losses

Bearings lubricated by the oil bath method are partially submerged or, in special situations, completely submerged. The drag losses that occur when the bearing is rotating in an oil bath contribute to the total frictional moment and should not be neglected. Drag losses are not only influenced by bearing speed, oil viscosity and oil level, but also by the size and geometry of the oil reservoir. External oil agitation, which can originate from mechanical elements, like gears or cams, in close proximity to the bearing should also be taken into consideration.

Drag losses in oil bath lubrication

The SKF model for calculating the drag losses in oil bath lubrication considers resistance of the rolling elements when moving through the oil and includes the effects of the viscosity of the oil. It provides results with sufficient accuracy under the following conditions:

- The oil reservoir is large. Effects from reservoir size and geometry or external oil agitation are negligible.
- The shaft is horizontal.
- The inner ring rotates at a constant speed. The speed is not higher than the permissible speed.
- The oil viscosity is within the limits:
 - $\leq 500 \text{ mm}^2/\text{s}$ when the bearing is submerged up to half or less (oil level $H \leq D/2$)
 - $\leq 250 \text{ mm}^2/\text{s}$ when the bearing is submerged more than half (oil level $H > D/2$)

The oil level H is measured from the lowest contact point between the outer ring raceway and the rolling element (→ **fig. 2, page 112**). It can be estimated with sufficient accuracy using:

- for tapered roller bearings:
outside diameter D [mm]
- for all other radial rolling bearings:
outer ring mean diameter [mm]
 $= 0,5 (D + D_1)$

The frictional moment of drag losses for ball bearings can be estimated using

$$M_{\text{drag}} = 0,4 V_M K_{\text{ball}} d_m^5 n^2 + 1,093 \times 10^{-7} n^2 d_m^3 \left(\frac{n d_m^2 f_t}{v} \right)^{-1,379} R_s$$

The frictional moment of drag losses for roller bearings can be estimated using

$$M_{\text{drag}} = 4 V_M K_{\text{roll}} C_w B d_m^4 n^2 + 1,093 \times 10^{-7} n^2 d_m^3 \left(\frac{n d_m^2 f_t}{v} \right)^{-1,379} R_s$$

The rolling element related constants are:

$$K_{\text{ball}} = \frac{i_{rw} K_z (d + D)}{D - d} 10^{-12}$$

$$K_{\text{roll}} = \frac{K_L K_z (d + D)}{D - d} 10^{-12}$$

The variables and functions used in the equations for the frictional moment of drag losses are:

$$C_w = 2,789 \times 10^{-10} l_D^3 - 2,786 \times 10^{-4} l_D^2 + 0,0195 l_D + 0,6439$$

$$l_D = 5 \frac{K_L B}{d_m}$$

$$f_t = \begin{cases} \sin(0,5 t), & \text{when } 0 \leq t \leq \pi \\ 1, & \text{when } \pi < t < 2\pi \end{cases}$$

$$R_s = 0,36 d_m^2 (t - \sin t) f_A$$

$$t = 2 \cos^{-1} \left(\frac{0,6 d_m - H}{0,6 d_m} \right) \quad \text{When } H \geq d_m, \text{ use } H = d_m$$

$$f_A = 0,05 \frac{K_z (D + d)}{D - d}$$

where

M_{drag} = frictional moment of drag losses [Nmm]

V_M = drag loss factor (→ **diagram 4, page 112**)

B = bearing width [mm]
 • for tapered roller bearings → width T
 • for thrust bearings → height H

d_m = bearing mean diameter [mm]
 = $0,5 (d + D)$

d = bearing bore diameter [mm]

D = bearing outside diameter [mm]

H = oil level (→ **fig. 2, page 112**) [mm]

i_{rw} = number of ball rows

K_z = bearing type related geometric constant (→ **table 5, page 112**)

K_L = roller bearing type related geometric constant (→ **table 5, page 112**)

n = rotational speed [r/min]

ν = actual operating viscosity of the lubricant [mm^2/s]

Friction

Drag losses for vertical shaft arrangements

To calculate drag losses for vertical shaft arrangements, the model for fully submerged bearings can be used to get an approximate value. The obtained value for M_{drag} should be multiplied by a factor equal to the width (height) that is submerged relative to the total bearing width (height).

Drag losses for oil jet lubrication

To calculate drag losses for the oil jet lubrication method, use the oil bath model, with the oil level H at half the diameter of the lowest rolling element. The obtained value for M_{drag} should be multiplied by a factor of two. Certainly, this approximation can vary depending on the rate and direction of oil. However, if the oil level H is known when oil is flowing and the bearing is at a stand-still, this value can be used directly in the drag loss calculation to obtain a more accurate estimate.

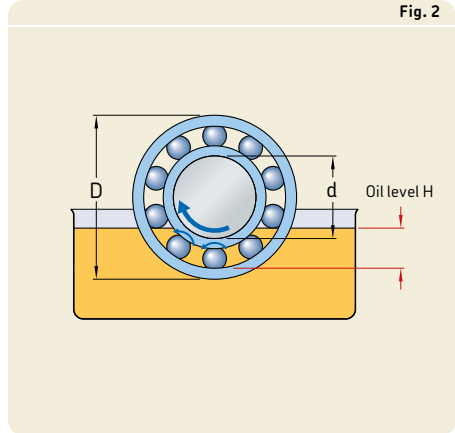
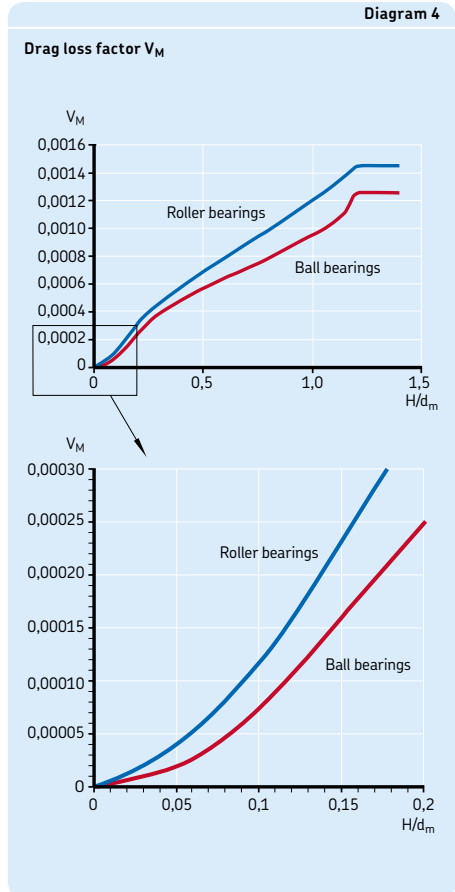

Fig. 2

Geometric constants K_Z and K_L		
Bearing type	Geometric constants K_Z	K_L
Deep groove ball bearings – single and double row	3,1	–
Angular contact ball bearings – single row	4,4	–
– double row	3,1	–
– four-point contact	3,1	–
Self-aligning ball bearings	4,8	–
Cylindrical roller bearings – with a cage	5,1	0,65
– full complement	6,2	0,7
Tapered roller bearings	6	0,7
Spherical roller bearings	5,5	0,8
CARB toroidal roller bearings – with a cage	5,3	0,8
– full complement	6	0,75
Thrust ball bearings	3,8	–
Cylindrical roller thrust bearings	4,4	0,43
Spherical roller thrust bearings	5,6	0,58 ¹⁾

¹⁾ Only for single mounted bearings



Additional effects on the frictional moment

Effects of clearance and misalignment on friction

Changes in clearance or misalignment in bearings influence the frictional moment. The model above considers normal internal operating clearance and an aligned bearing. However, high bearing operating temperatures or speeds might reduce internal bearing clearance, which can increase friction. Misalignment generally increases friction. However, for self-aligning ball bearings, spherical roller bearings, CARB toroidal roller bearings and spherical roller thrust bearings, the corresponding increase of friction is negligible.

For applications that are sensitive to changes in clearance or misalignment, contact the SKF application engineering service.

Effects of grease fill on friction

When a bearing has just been lubricated or relubricated with the recommended amount of grease, the bearing can realize considerably higher frictional values than had been calculated originally. It can be seen as an increase in operating temperature. The time it takes for friction to decrease depends on the speed of the application and how long it takes for the grease to distribute itself within the free space in the bearing.

This effect can be estimated by multiplying the rolling frictional moment by a factor of 2 to 4, where 2 applies for light series bearings (narrow width series) and 4 for heavy series bearings.

However, after the running-in period, the values for the frictional moment in the bearing is similar to, or even lower than the values for oil lubricated bearings. Bearings filled with an excessive amount of grease may show higher values of friction. For additional information, refer to *Relubrication* (→ page 252), or contact the SKF application engineering service.

Additional information for specific bearing types and performance classes

Hybrid bearings

The higher values for the modulus of elasticity of rolling elements made of silicon nitride decreases the contact area in the raceways to significantly reduce rolling and sliding friction. Additionally, the lower density of ceramic rolling elements, when compared with steel, reduces the centrifugal forces, which also may reduce friction at high speeds.

Standard hybrid ball bearings

Using the above equations, the frictional moment for hybrid angular contact ball bearings can be calculated by multiplying the geometric constants R_3 and S_3 of the bearings with steel rolling elements by a factor 0,41, that is 0,41 R_3 and 0,41 S_3 , respectively.

Hybrid deep groove ball bearings in high-speed applications are usually preloaded axially. Under these conditions, hybrid deep groove ball bearings behave like angular contact ball bearings with a similar reduced frictional moment. SKF recommends contacting the SKF application engineering service when calculating the frictional moment for hybrid deep groove ball bearings.

Hybrid super-precision bearings

For information about the frictional moment for SKF super-precision bearings, contact the SKF application engineering service.

SKF Energy Efficient bearings

To obtain values for the frictional moment for SKF Energy Efficient (E2) bearings, SKF recommends using the tools available online at skf.com/bearingcalculator.

Y-bearings (insert bearings)

To obtain values for the frictional moment for Y-bearings, SKF recommends using the tools available online at skf.com/bearingcalculator.

Needle roller bearings

To obtain values for the frictional moment for needle roller bearings, SKF recommends using the tools available online at skf.com/bearingcalculator.

C

Starting torque

The starting torque of a rolling bearing is defined as the frictional moment that must be overcome by the bearing to start rotating. Therefore, only the sliding frictional moment and the frictional moment of seals, if applied, must be taken into consideration. At an ambient temperature of 20 to 30 °C (70 to 85 °F), the starting torque can be calculated using

$$M_{\text{start}} = M_{\text{sl}} + M_{\text{seal}}$$

where

M_{start} = starting frictional moment [Nmm]

M_{sl} = sliding frictional moment [Nmm]

M_{seal} = frictional moment of the seals [Nmm]

However, the starting torque can be considerably higher for roller bearings with a large contact angle. It can be up to four times higher for tapered roller bearings in the 313, 322 B, 323 B and T7FC series, and up to eight times higher for spherical roller thrust bearings.

Power loss and bearing temperature

The power loss in a bearing as a result of bearing friction can be estimated using

$$N_R = 1,05 \times 10^{-4} M n$$

where

N_R = power loss [W]

M = total frictional moment of the bearing [Nmm]

n = rotational speed [r/min]

The cooling factor W_s is defined as the heat being removed from the bearing per degree of temperature difference between the bearing and ambient. If the value of W_s is known, a rough estimate of the temperature increase in the bearing can be obtained using

$$\Delta T = N_R / W_s$$

where

ΔT = temperature increase [°C]

N_R = power loss [W]

W_s = cooling factor [W/°C]

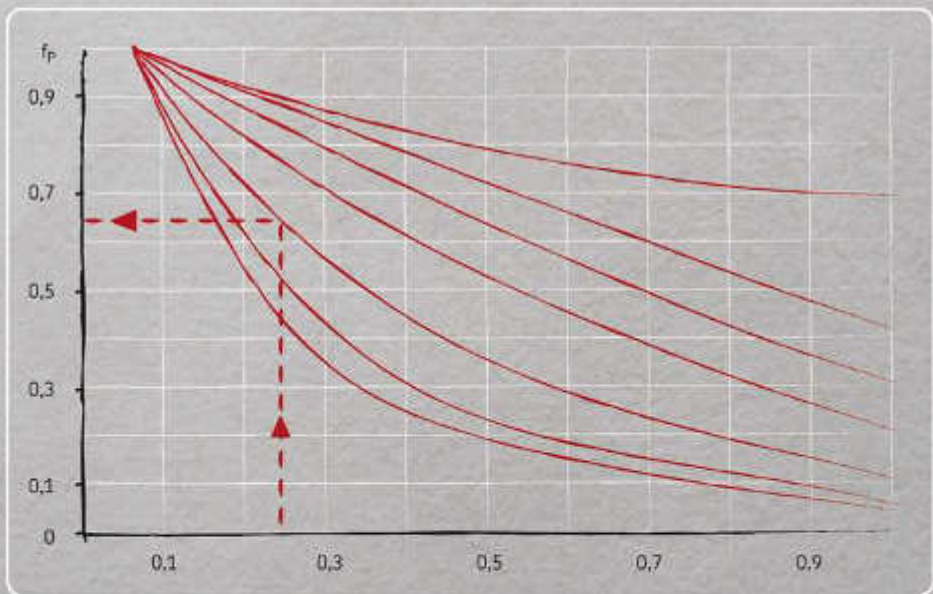

Speeds

Basics of bearing speed	118
Reference speed	118
Influence of load and oil viscosity on reference speed	120
Oil lubrication	120
Grease lubrication	120
Speeds above the reference speed	125
Limiting speed	126
Special cases	127
Slow speeds	127
Oscillating movements	127
Vibration generation at high speeds ..	128
Excitation due to a varying number of loaded rolling elements	128
Accuracy of associated components	128
Influence of the bearing on the vibration behaviour of the application	128

D

Basics of bearing speed

There is a limit to the speed at which rolling bearings can be operated. Generally, the temperature limit of the lubricant or the material of the bearing components sets the speed limit.

The speed at which a bearing reaches its operating temperature limit depends on the heat generated in the bearing, any externally applied heat, and the amount of heat that can be transferred away from the bearing.

The amount of heat generated in the bearing depends on the bearing type and size, internal design, load, lubrication and alignment. Other factors include cage design, accuracy and internal clearance.

In the product tables, two speeds are generally listed: reference speed (thermal) and limiting speed (mechanical).

In general, the limiting speed is higher than the reference speed for a bearing. For some bearing series, however, due to favourable frictional characteristics compared to the mechanical ability of the bearing to sustain high speeds, the reference speed can be higher than the limiting speed. In every case, however, the limiting speed of the bearing must always be observed, even under the most favourable operating conditions.

Reference speed

The main purpose of the reference speed (thermal) is to provide a quick assessment of the speed capabilities of a bearing based on standardized reference values for the heat flow density as established in ISO 15312 (→ **diagram 1**).

This ISO standard provides reference operating conditions and standard values for the heat flow under those reference conditions. The standard reference heat flow densities shown in **diagram 1** are within the values found in bearing applications, shown as the shaded area.

To assess the actual temperature rise and heat flow in a particular application, a detailed analysis of the cooling conditions surrounding the bearing would be required. This is outside the scope of the present ISO speed rating standard. For detailed temperature rise calcu-

lations, contact the SKF application engineering service.

The values of the reference speeds are based on ISO 15312. The ISO standard, established for oil lubrication, is also valid for grease lubrication. Outer ring rotation is not covered by the ISO standard. Therefore, it may be necessary to reduce the reference speed ratings in applications where the outer ring rotates. For additional information, contact the SKF application engineering service.

For bearings with contact seals, speed capability of the bearing is not determined by the frictional heat generated in the rolling element / raceway contacts. Therefore, these bearings are not included in the ISO reference speed standard and only the limiting speeds are listed in the product tables.

The ISO reference speed is based on open bearings under the following operating conditions:

- light loads:
 - radial load $P = 0,05 C_0$ for radial bearings
 - axial load $P = 0,02 C_0$ for thrust bearings
- nominal temperature increase of $50\text{ }^\circ\text{C}$ ($90\text{ }^\circ\text{F}$) above an ambient reference temperature of $20\text{ }^\circ\text{C}$ ($70\text{ }^\circ\text{F}$)
- good lubrication and clean conditions
- normal internal clearance (→ *Bearing internal clearance*, **page 149**)

SKF values for the reference speed comply with these conditions, except for the clearance condition. The SKF values are valid for sufficient operating clearance (→ *Bearing internal clearance*, **page 149**), which in some cases might require bearings with an initial clearance greater than normal.

Grease lubricated bearings may undergo a temperature peak during initial start-up, requiring a running-in period before they reach normal operating temperature.

Diagram 1

Heat flow density

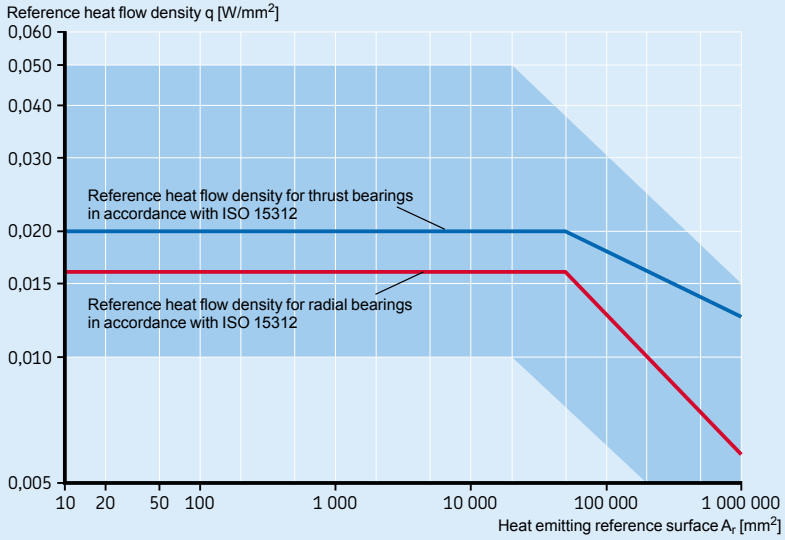

D

Speeds

Influence of load and oil viscosity on reference speed

When load or viscosity values higher than the reference values are applied, the frictional resistance increases and the reference speed should be adjusted. Conversely, lower viscosity or load values can enable higher speeds.

The influence of load and kinematic viscosity on the reference speed can be estimated from the diagrams referenced in the following:

- for radial ball bearings (→ **diagram 2**)
- for radial roller bearings (→ **diagram 3, page 122**)
- for thrust ball bearings (→ **diagram 4, page 123**)
- for thrust roller bearings (→ **diagram 5, page 124**)

Oil lubrication

Values for the adjustment factors for oil lubrication can be obtained from **diagrams 2 to 5** as a function of P/C_0 and the bearing mean diameter d_m :

- f_p for the influence of the equivalent dynamic bearing load P
- f_v for the influence of the viscosity

where

P = equivalent dynamic bearing load [kN]

C_0 = basic static load rating [kN]

(→ **product tables**)

d_m = bearing mean diameter [mm]
= 0,5 (d + D)

The viscosity values in the diagrams are expressed with ISO designations, for example ISO VG 32, where 32 is the oil viscosity at 40 °C (105 °F).

The adjusted reference speed for oil lubrication can be estimated using

$$n_{ar} = n_r f_p f_v$$

where:

n_{ar} = adjusted reference speed [r/min]

n_r = nominal reference speed [r/min]

(→ **product tables**)

f_p = adjustment factor for bearing load P

f_v = adjustment factor for oil viscosity

Grease lubrication

The values for the adjustment factor for the bearing load (f_p) provided in **diagrams 2 to 5** are also valid for grease lubrication. When greases with a base oil viscosity between 100 and 200 mm²/s at 40 °C (105 °F) are used, the value for the adjustment factor for the viscosity $f_v = 1$. For other base oil viscosities, the value for f_v needs to be compared with the value for ISO VG 150 oil. The adjusted reference speed for grease lubrication can be estimated using

$$n_{ar} = n_r f_p \frac{f_{v \text{ actual base oil viscosity}}}{f_{v \text{ ISO VG150}}}$$

Diagram 2

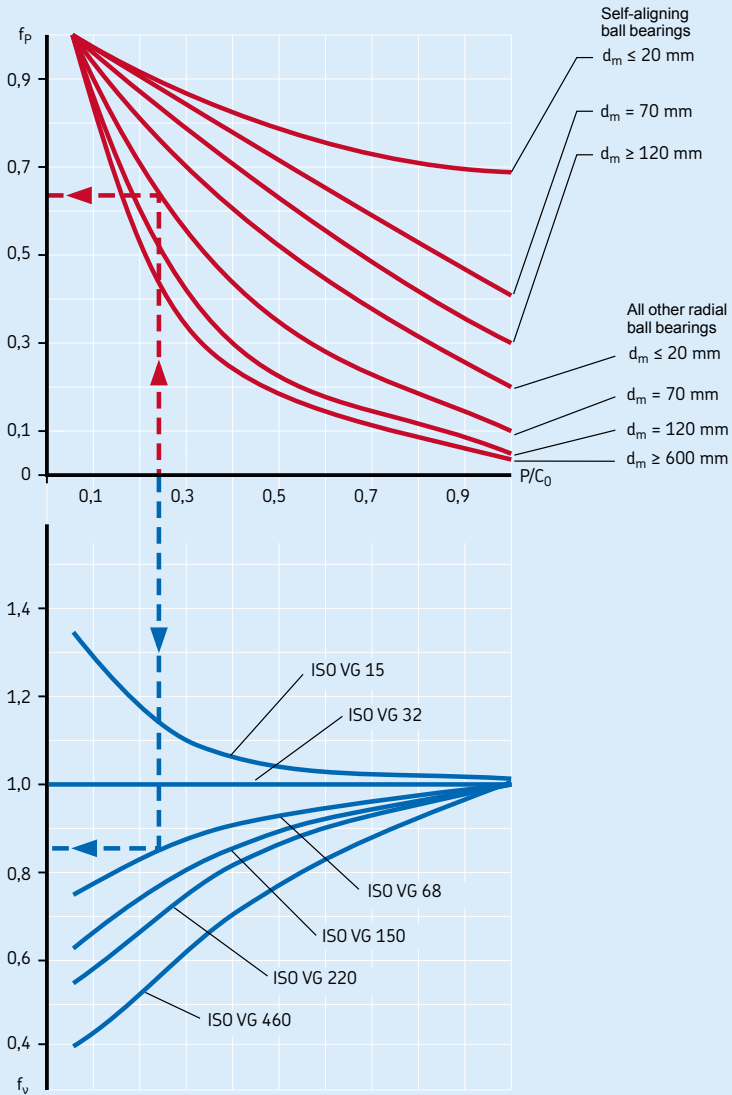
Adjustment factors f_p and f_v for radial ball bearings

D

Adjustment factors f_p and f_v for radial roller bearings

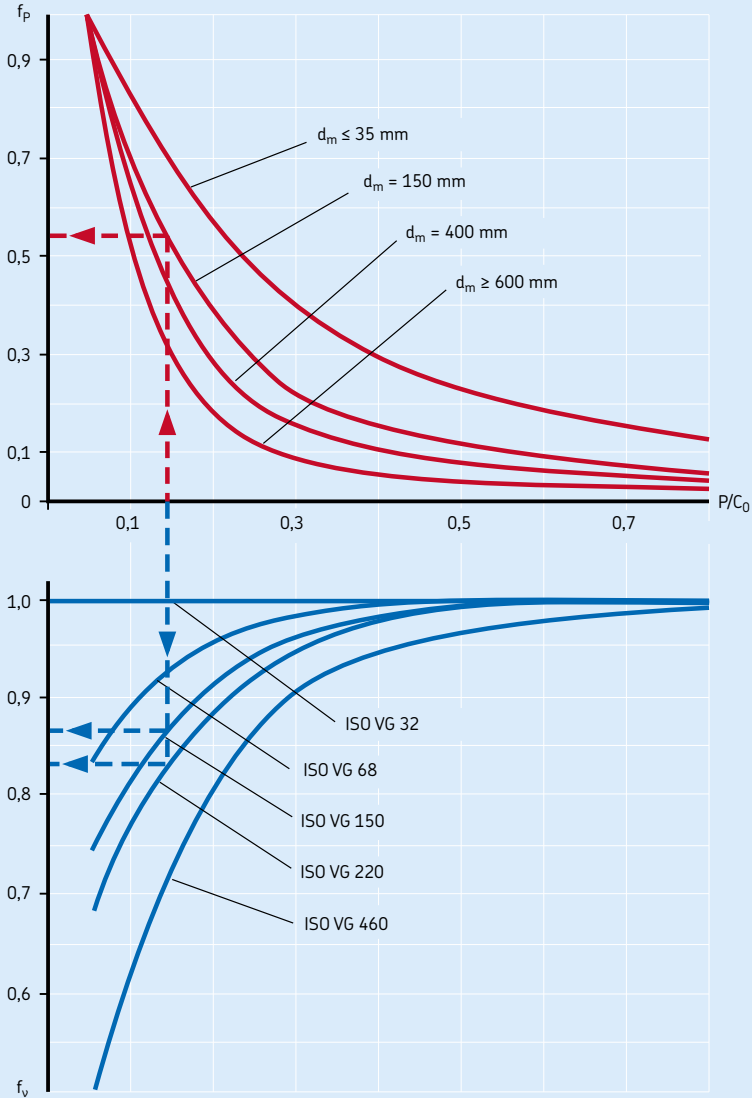
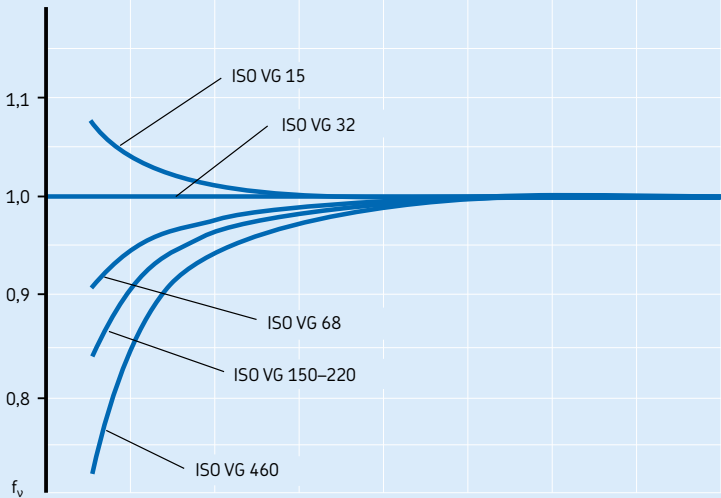
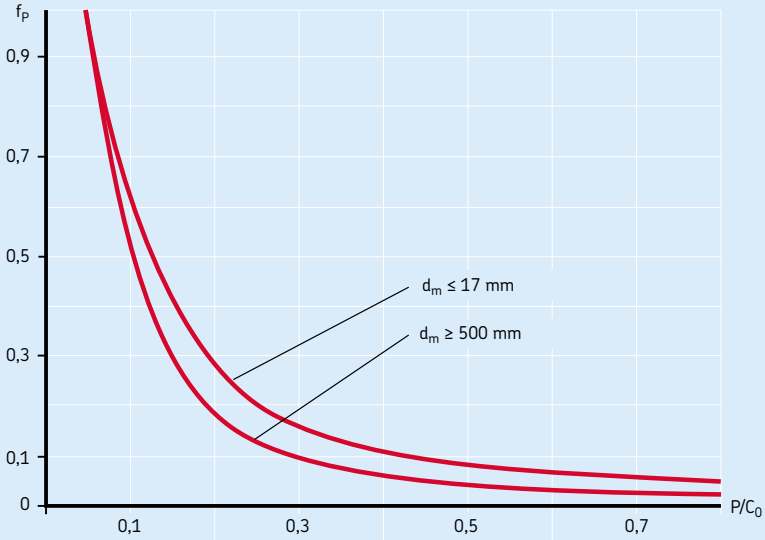
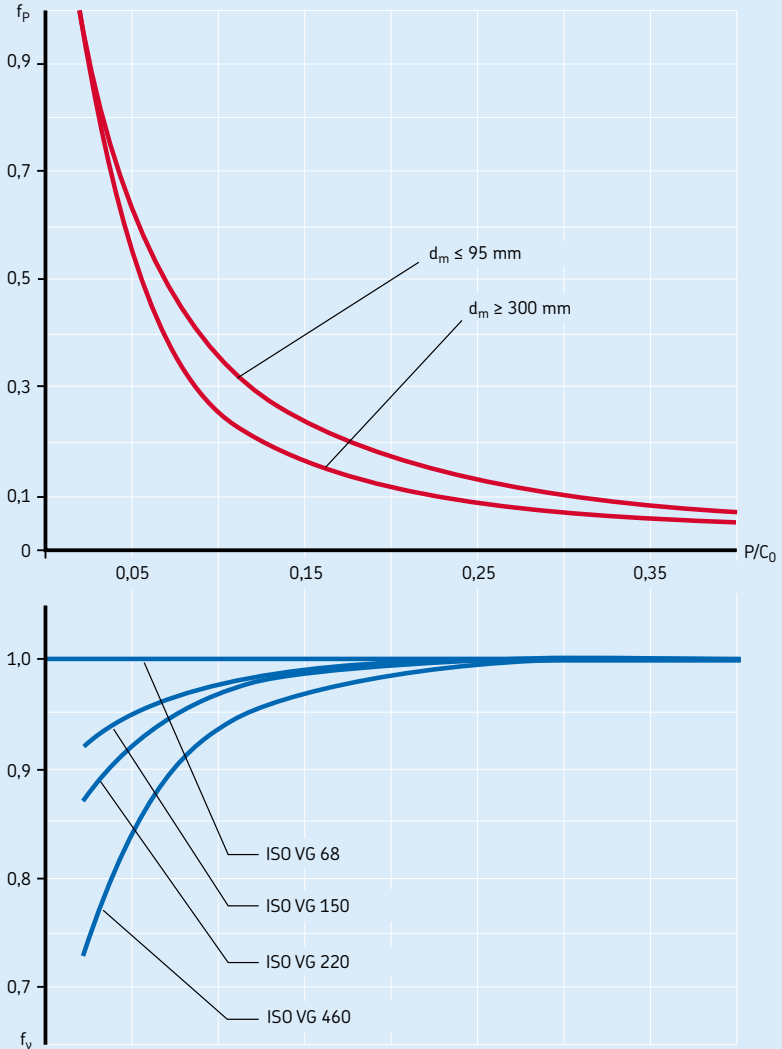

Diagram 4

Adjustment factors f_p and f_v for thrust ball bearings

D

Adjustment factors f_p and f_v for thrust roller bearings



Example 1

An SKF Explorer 6210 deep groove ball bearing is lubricated via an oil bath. The oil viscosity is $68 \text{ mm}^2/\text{s}$ at $40 \text{ }^\circ\text{C}$ ($105 \text{ }^\circ\text{F}$), load $P = 0,24 C_0$. What is the adjusted reference speed?

For bearing 6210: $d_m = 0,5 (50 + 90) = 70 \text{ mm}$ and $n_r = 15\,000 \text{ r/min}$. From **diagram 2, page 121**, with $d_m = 70 \text{ mm}$ and $P/C_0 = 0,24$, $f_P = 0,63$ and with $P/C_0 = 0,24$ and ISO VG 68, $f_v = 0,85$.

$$n_{ar} = 15\,000 \times 0,63 \times 0,85 = 8\,030 \text{ r/min}$$

Note that the limiting speed for this bearing is $10\,000 \text{ r/min}$, which is higher than its adjusted reference speed. In cases like this, the lower of the two rated speeds is the most significant for the service life of the bearing. In general, speeds up to the adjusted reference speed provide conditions favourable for extended bearing service life. Higher speeds up to the bearing limiting speed can, in principle, be adopted after further assessment of the specific temperature conditions surrounding the bearing arrangement.

Example 2

A grease lubricated SKF Explorer 22222 E spherical roller bearing is subjected to a load $P = 0,15 C_0$. The grease has a base oil viscosity of $220 \text{ mm}^2/\text{s}$ at $40 \text{ }^\circ\text{C}$ ($105 \text{ }^\circ\text{F}$). What is the adjusted reference speed?

For bearing 22222 E: $d_m = 0,5 (110 + 200) = 155 \text{ mm}$ and $n_r = 3\,000 \text{ r/min}$. From **diagram 3, page 122**, with $d_m = 155 \text{ mm}$ and $P/C_0 = 0,15$, $f_P = 0,53$ and with $P/C_0 = 0,15$ and ISO VG 220, $f_{v \text{ actual}} = 0,83$; with $P/C_0 = 0,15$ and ISO VG 150, $f_{v \text{ ISO VG150}} = 0,87$.

$$n_{ar} = 3\,000 \times 0,53 \times 0,83/0,87 = 1\,520 \text{ r/min}$$

Up to this speed, the bearing thermal conditions are generally considered normal. Higher speeds, up to the limiting speed of $4\,000 \text{ r/min}$, can also be considered under certain circumstances. This would require an assessment of the temperature rise of the application based on the actual frictional and cooling conditions within the application. In cases like this, the lubricant, heat dissipation, bearing internal clearance and accuracy of the bearing seats must be verified and adapted to accommodate higher speeds. For these types of evaluations,

contact the SKF application engineering service.

Speeds above the reference speed

As mentioned in the previous example, it is possible to operate bearings at speeds above the reference speed provided the increase in operating temperature can be controlled and does not have a negative impact on the bearing or the application.

Prior to operating a bearing above its reference speed, make sure that all bearing components, including the cage(s) and seal(s), can accommodate the increased temperatures. Also, check that clearance or preload values and the lubricant can accommodate higher temperatures.

The operating temperature can be kept under control if friction within the bearing can be reduced or if heat can be removed from the bearing arrangement.

Friction can be reduced to some extent with an optimized lubrication system that applies accurately metered, small quantities of grease or oil to the bearing.

Heat can be removed from a bearing arrangement in a number of ways. Typical solutions to cool the oil in oil lubricated applications include fans, auxiliary coolers and circulating oil systems (\rightarrow *Oil lubrication methods, page 262*).

For bearings that accommodate axial displacement between one bearing ring and its seat, it is important to check that the bearing can move axially under actual operating conditions. In some cases, it may also be necessary to improve other speed-limiting factors such as bearing running accuracy, the cage design and bearing materials. Any increase in bearing temperature lowers the viscosity and effectiveness of the lubricant, making it more difficult for the lubricant to maintain an effective hydrodynamic film.

In most cases, this further increases friction and frictional heat. When temperatures increase to the point that the inner ring becomes significantly hotter than the outer ring, the operating clearance in the bearing can be reduced to the point that the bearing seizes. Any increase in speed above the reference speed generally means that the temperature difference between the inner and outer rings is

greater than normal. Therefore, a bearing with a larger internal clearance than initially selected might be required (→ *Bearing internal clearance*, **page 149**). It may also be necessary to look more closely at the temperature distribution in the bearing, as well as the temperature limits of the cage and lubricant as steady-state temperatures higher than 70 °C (160 °F) may reduce their service life (→ *Polymer cages*, **page 153** and *Lubricating greases*, **page 244**).

For specific assessments of applications operating above the reference speed (thermal), contact the SKF application engineering service. As a general rule, the limiting speed of the bearing must be observed even under the most favourable frictional and cooling conditions.

Limiting speed

The limiting speed (mechanical) is determined by criteria that include the form stability or strength of the cage, lubrication of the cage guiding surfaces, centrifugal and gyrotory forces acting on the rolling elements, bearing-housing precision and other speed-limiting factors, such as seals and the lubricant for sealed bearings.

Experience shows that even under the most favourable loading and frictional conditions, there are maximum speeds that should not be exceeded for technical reasons or because of the very high costs involved in keeping the running conditions stable for any length of time.

The limiting speeds listed in the product tables are valid for the basic bearing design. In cases where the limiting speed is higher than the reference speed, temperatures significantly higher than the reference value can be expected. Under these conditions, appropriate measures might be necessary (→ *Speeds above the reference speed*, **page 125**). If these measures are not adequate, the bearing internal clearance and accuracy of the housing and shaft seats should be verified and adapted to the more demanding operating conditions (→ *Tolerances for total radial run-out*, **page 200**).

The compatibility of the materials in the bearing system must also be considered relative to the bearing temperature and required

service life (→ *Materials for rolling bearings*, **page 150** and *Lubricating greases*, **page 244**). When the steady state operating temperature is higher than the maximum recommended by the bearing material stabilization class, i.e. 120 °C (250 °F) for the SN class (→ *Influence of the operating temperature*, **page 82**), a bearing with a higher stabilization class might be necessary to maintain the mounting stress and bearing internal clearance.

For grease lubrication, additional factors such as lubrication of the cage guiding surfaces and grease consistency at the operating temperature should be taken into consideration (→ *Grease lubrication*, **page 242**).

Some open ball bearings have very low friction, and the reference speeds listed might be higher than the limiting speeds. Therefore, the adjusted reference speed needs to be calculated and compared to the limiting speed. The lower of the two values should be used.

To function satisfactorily, particularly at high speeds, bearings must be subjected to a given minimum load. For detailed information about the required minimum load, refer to *Loads* in the relevant product chapter.

In some special cases, such as for some cylindrical roller bearings, the choice of an alternative cage can make it possible to operate bearings at speeds higher than the limiting speed for the standard execution listed in the tables (→ *Permissible speed*, **table 9**, **page 600**).

In general, if the limiting speed is not able to meet the requirements of the application, modifications to the bearing, lubrication system or application may be required. Modifications could include improving bearing running accuracy, changing cage materials, changing the lubricant or lubrication method, or improving heat dissipation.

In that case, SKF recommends contacting the SKF application engineering service for assistance.

Special cases

In certain applications, the speed limits are superseded in importance by other considerations.

Slow speeds

At very slow speeds, it is very difficult for an elasto-hydrodynamic lubricant film to be built up in the contact areas between the rolling elements and raceways. In these applications, lubricants containing EP additives should be considered (→ *Grease lubrication*, **page 242**). Alternatively, consider the use of Solid Oil (→ **page 1185**).

Oscillating movements

With this type of movement, the direction of rotation changes before the bearing has completed a single revolution. As the rotational speed is zero at the point where the direction of rotation is reversed, a full hydrodynamic lubricant film is impossible to maintain. As a result, SKF recommends using a lubricant containing an effective EP additive to maintain a boundary lubricant film capable of supporting the applied loads. Hybrid bearings (→ **page 1219**) perform well under insufficient lubrication conditions and can therefore provide favourable results in applications where rapid accelerations, decelerations and load reversals (directional changes) occur.

In general, it is not possible to give a limit or a rating for the speed of oscillating movements, as the upper limit is not dictated by a heat balance but by the inertial forces that come into play. With each reversal, there is a danger that inertia causes the rolling elements to slide for a short distance and smear the raceways. The effects of accelerations and decelerations depend on the mass of the rolling elements and cage, the type and quantity of lubricant, the operating clearance and the loads on the bearing.

D

Vibration generation at high speeds

When bearings operate at high speeds, high over-rolling frequencies are generated in the bearing and a high-pitched noise can be expected from the application. What is perceived as “bearing noise” is the audible effect of the vibration generated by the bearing and transmitted through the surrounding structure. The surrounding structure also contributes to the attenuation or amplification of the noise characteristics of the application. In addressing noise issues in high-speed bearing applications, it is useful to consider the following additional aspects.

Excitation due to a varying number of loaded rolling elements

When a radial load is applied to a bearing, the number of rolling elements carrying the load varies slightly during operation, this means alternating between 2–3–2–3. This generates a displacement in the direction of the load. The resulting vibration cannot be avoided, but can be reduced by applying an axial preload to load all the rolling elements. This, however, is not possible for cylindrical roller, needle roller and CARB toroidal roller bearings and is not recommended for double-row bearings.

Accuracy of associated components

In cases where there is a tight fit between the bearing ring and the housing or shaft, the bearing ring may take the shape of the adjacent component. If form deviations are present, these may cause vibrations during operation. Therefore, it is important to machine the shaft and housing seats to the required tolerances (→ *Tolerances for total radial run-out*, page 200).

Presence of local raceway damage or indentations caused by solid contaminants also reduce the accuracy of the raceway micro-geometry and increase vibrations in the bearing. High cleanliness of the lubricant and protection from solid contaminants can help to reduce bearing noise issues in an application.

Influence of the bearing on the vibration behaviour of the application

In many applications, bearing stiffness is of the same order as the stiffness of the surrounding structure. This opens the possibility of reducing vibrations in an application by either replacing the bearing or adjusting the preload or clearance in the bearing arrangement. There are three ways to reduce vibration:

- Remove the critical excitation vibration from the application.
- Dampen the critical excitation vibration between excitant component and resonant components.
- Change the stiffness of the structure to change the critical frequency.

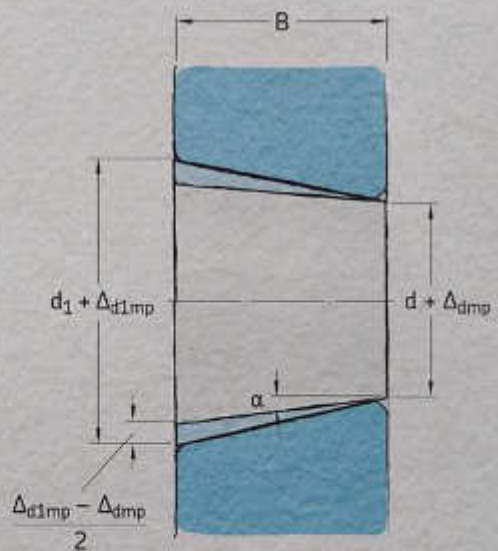
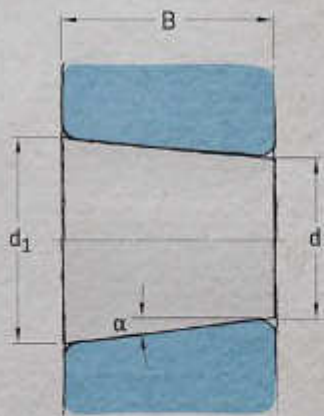

Bearing specifics

Dimensions	132
Chamfer dimensions.	132
Tolerances	132
Tolerance symbols	132
Diameter series identification	132
Tolerance tables	133
Chamfer dimension limits	133
Bearing internal clearance	149
Materials for rolling bearings	150
Materials for bearing rings and rolling elements	151
Bearing steels for through- hardening	151
Bearing steels for induction- hardening	151
Bearing steels for case-hardening . . .	151
Stainless steels.	151
High-temperature bearing steels . . .	151
Ceramics.	152
Cage materials	152
Stamped metal cages.	152
Machined metal cages	153
Polymer cages	153
Cages made of other materials	155
Seal materials.	155
Acrylonitrile-butadiene rubber	155
Hydrogenated acrylonitrile- butadiene rubber	156
Fluoro rubber	156
Polytetrafluoroethylene	156
Polyurethane	157
Lubricants.	157
Coatings	157



Dimensions

For information about main dimensions of a bearing, refer to *Boundary dimensions* (→ page 40).

Chamfer dimensions

Minimum values for the chamfer dimensions (→ fig. 1) in the radial direction (r_1, r_3) and the axial direction (r_2, r_4) are listed in the product tables. These values are in accordance with the general plans listed in the following standards:

- ISO 15, ISO 12043 and ISO 12044 for radial rolling bearings
- ISO 355 for radial tapered roller bearings
- ISO 104 for thrust rolling bearings

The appropriate maximum chamfer limits that are important when dimensioning fillet radii are in accordance with ISO 582 (→ *Tolerances*).

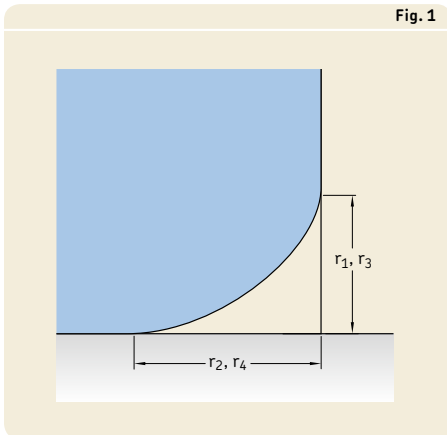

Fig. 1

Tolerances

The dimensional and running accuracy of rolling bearings has been standardized internationally. In addition to the Normal tolerances, the ISO standards also cover closer tolerances, such as:

- tolerance class 6, which corresponds to SKF P6 tolerance class
- tolerance class 5, which corresponds to SKF P5 tolerance class

For special applications like machine tool spindles, SKF also manufactures bearings with higher accuracy. These include the P4, P4A, PA9A, SP and UP tolerance classes. For additional information, refer to *Super-precision bearings* (→ skf.com/super-precision).

For tolerance information about each bearing type, refer to *Tolerances* in the relevant product chapter. Bearings with higher accuracy than Normal are typically identified by a designation suffix for the tolerance class.

Tolerance symbols

The tolerance symbols and their definitions are provided in **table 1** (→ page 134).

Diameter series identification

The bore and outside diameter variation tolerances V_{dp} and V_{Dp} for metric rolling bearings (→ **tables 3 to 5, pages 137 to 139** – except tapered roller bearings) are not universally valid for all diameter series. To determine the diameter series of a radial bearing, refer to **table 2** (→ page 136).

Tolerance tables

The actual tolerances are listed in the tables referenced in the following:

- Normal tolerances for radial bearings, except tapered roller bearings (→ **table 3, page 137**)
- P6 class tolerances for radial bearings, except tapered roller bearings (→ **table 4, page 138**)
- P5 class tolerances for radial bearings, except tapered roller bearings (→ **table 5, page 139**)
- Normal and CL7C class tolerances for metric tapered roller bearings (→ **table 6, page 140**)
- CLN class tolerances for metric tapered roller bearings (→ **table 7, page 141**)
- P5 class tolerances for metric tapered roller bearings (→ **table 8, page 142**)
- Tolerances for inch tapered roller bearings (→ **table 9, page 143**)
- Tolerances for thrust bearings (→ **table 10, page 144**)
- Normal, P6 and P5 class tolerances for tapered bore, taper 1:12 (→ **table 11, page 145**)
- Normal tolerances for tapered bore, taper 1:30 (→ **table 12, page 146**)

Where standardized, the values are in accordance with ISO 492, ISO 199 and ANSI/ABMA Std 19.2.

Chamfer dimension limits

To prevent the improper dimensioning of fillets on associated components for rolling bearings and facilitate calculations to locate retaining rings, the maximum chamfer limits (→ **fig. 2**) for the relevant minimum chamfer dimensions (→ **product tables**) are listed in the following tables:

- chamfer dimension limits for metric radial and thrust bearings, except tapered roller bearings (→ **table 13, page 147**)
- chamfer dimension limits for metric radial tapered roller bearings (→ **table 14, page 147**)
- chamfer dimension limits for inch tapered roller bearings (→ **table 15, page 148**)

The limits for metric bearings are in accordance with ISO 582. The limits for inch tapered roller bearings, which differ considerably from those for metric bearings, are described in ANSI/ABMA 19.2, but are not standardized.

Example

What is the largest radial value ($r_{1\max}$) for the chamfer of a 6211 deep groove ball bearing? From the product table (→ **page 328**),

$r_{1\min} = 1,5$ mm and $d = 55$ mm.

From **table 13** (→ **page 147**) with $r_{s\min} = 1,5$ mm and $d < 120$ mm, the largest radial value $r_{1\max} = 2,3$ mm.

E

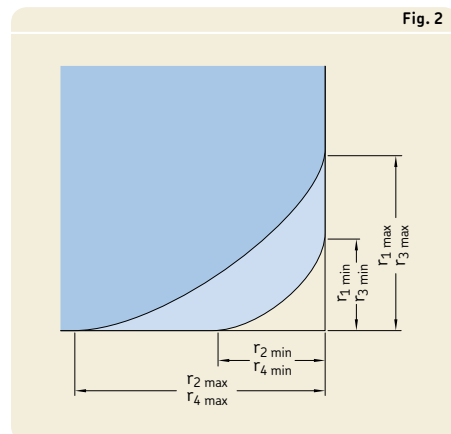

Table 1

Tolerance symbols	
Tolerance symbol	Definition
Bore diameter	
d	Nominal bore diameter
d_s	Single bore diameter
d_{mp}	1 Mean bore diameter; arithmetical mean of the largest and smallest single bore diameters in one plane 2 Mean diameter at the small end of a tapered bore; arithmetical mean of the largest and smallest single diameters
Δ_{d_s}	Deviation of a single bore diameter from the nominal ($\Delta_{d_s} = d_s - d$)
$\Delta_{d_{mp}}$	Deviation of the mean bore diameter from the nominal ($\Delta_{d_{mp}} = d_{mp} - d$)
V_{d_p}	Bore diameter variation; difference between the largest and smallest single bore diameters in one plane
$V_{d_{mp}}$	Mean bore diameter variation; difference between the largest and smallest mean bore diameters
d_1	Nominal diameter at the theoretical large end of a tapered bore
d_{1mp}	Mean diameter at the theoretical large end of a tapered bore; arithmetical mean of the largest and smallest single bore diameters
$\Delta_{d_{1mp}}$	Deviation of the mean bore diameter at the theoretical large end of a tapered bore from the nominal ($\Delta_{d_{1mp}} = d_{1mp} - d_1$)
Outside diameter	
D	Nominal outside diameter
D_s	Single outside diameter
D_{mp}	Mean outside diameter; arithmetical mean of the largest and smallest single outside diameters in one plane
Δ_{D_s}	Deviation of a single outside diameter from the nominal ($\Delta_{D_s} = D_s - D$)
$\Delta_{D_{mp}}$	Deviation of the mean outside diameter from the nominal ($\Delta_{D_{mp}} = D_{mp} - D$)
V_{D_p}	Outside diameter variation; difference between the largest and smallest single outside diameters in one plane
$V_{D_{mp}}$	Mean outside diameter variation; difference between the largest and smallest mean outside diameters
Chamfer limits	
r_s	Single chamfer dimension
$r_{s \min}$	Smallest single chamfer dimension of $r_s, r_1, r_2, r_3, r_4 \dots$
r_1, r_3	Radial direction chamfer dimensions
r_2, r_4	Axial direction chamfer dimensions

cont. table 1

Tolerance symbols

Tolerance symbol	Definition
Width or height	
B, C	Nominal width of an inner ring and outer ring, respectively
B_s, C_s	Single width of an inner ring and outer ring, respectively
B_{1s}, C_{1s}	Single width of an inner ring and outer ring, respectively, of a bearing specifically manufactured for paired mounting ¹⁾
Δ_{Bs}, Δ_{Cs}	Deviation of a single inner ring width or single outer ring width from the nominal (Δ _{Bs} = B _s - B; Δ _{Cs} = C _s - C; Δ _{B1s} = B _{1s} - B ₁ ; Δ _{C1s} = C _{1s} - C ₁)
V_{Bs}, V_{Cs}	Ring width variation; difference between the largest and smallest single widths of an inner ring and outer ring, respectively
T	1 Nominal width (abutment width) of a tapered roller bearing; distance between an inner ring (cone) back face and outer ring (cup) back face 2 Nominal height H of a single direction thrust bearing (except spherical roller thrust bearing → T ₄)
T₁	1 Nominal width of a tapered roller bearing, cone assembled with a master cup 2 Nominal height H ₂ of a single direction thrust ball bearing with a seat washer
T₂	1 Nominal width of a tapered roller bearing, cup assembled with a master cone 2 Nominal height H of a double direction thrust bearing
T₃	Nominal height H ₁ of a double direction thrust ball bearing with seat washers
T₄	Nominal height H of a spherical roller thrust bearing
Δ_{Ts}	1 Deviation of the effective single width of a tapered roller bearing from the nominal 2 Deviation of the height of a single direction thrust bearing from the nominal (except spherical roller thrust bearing → Δ _{T4s})
Δ_{T1s}	1 Deviation of an effective single width of a cone from the nominal 2 Deviation of the height of a single direction thrust ball bearing with a seat washer from the nominal
Δ_{T2s}	1 Deviation of the effective single width of a cup from the nominal 2 Deviation of the height of a double direction thrust bearing from the nominal
Δ_{T3s}	Deviation of the height of a double direction thrust ball bearing with seat washers from the nominal
Δ_{T4s}	Deviation of the height of a spherical roller thrust bearing from the nominal
Running accuracy	
K_{ia}, K_{ea}	Radial run-out of an inner ring and outer ring, respectively, of an assembled bearing
S_d	Side face run-out with reference to the bore (of an inner ring)
S_D	Outside inclination variation; variation in inclination of the outside cylindrical surface to the outer ring side face
S_{ia}, S_{ea}	Axial run-out of the inner ring and outer ring, respectively, of an assembled bearing
S_i, S_e	Thickness variation, measured from the middle of the raceway to the back (seat) face of a shaft washer and of a housing washer, respectively (axial run-out)

¹⁾ Does not apply to universally matchable angular contact ball bearings.



Bearing specifics

Table 2

Diameter series (radial bearings)			
Bearing type	Diameter series 7, 8, 9	0, 1	2, 3, 4
Deep groove ball bearings ¹⁾	617, 618, 619 627, 628 637, 638, 639	60 160, 161 630	2, 3 42, 43 62, 63, 64, 622, 623
Angular contact ball bearings		70	32, 33 72, 73 QJ 2, QJ 3
Self-aligning ball bearings ²⁾	139	10, 130	12, 13, 112 22, 23
Cylindrical roller bearings		NU 10, 20 NJ 10	NU 2, 3, 4, 12, 22, 23 NJ 2, 3, 4, 22, 23 NUP 2, 3, 22, 23 N 2, 3
Needle roller bearings	NA 48, 49, 69		
Full complement cylindrical roller bearings	NCF 18, 19, 28, 29 NNC 48, 49 NNCF 48, 49 NNCL 48, 49	NCF 30 NNF 50 NNCF 50	NCF 22 NJG 23
Spherical roller bearings	238, 239 248, 249	230, 231 240, 241	222, 232 213, 223
CARB toroidal roller bearings	C 39, 49, 59, 69	C 30, 31 C 40, 41	C 22, 23 C 32

¹⁾ Bearings 604, 607, 608, 609 belong to diameter series 0, bearings 623, 624, 625, 626, 627, 628 and 629 to diameter series 2, bearings 634, 635 and 638 to diameter series 3

²⁾ Bearing 108 belongs to diameter series 0, bearings 126, 127 and 129 to diameter series 2, bearing 135 to diameter series 3

Table 3

Normal tolerances for radial bearings, except tapered roller bearings

Inner ring

d		$\Delta_{dmp}^{1)}$		V_{dp} Diameter series 7, 8, 9 0, 1 2, 3, 4			V_{dmp}	Δ_{Bs}		Δ_{B1s}		V_{Bs}	K_{ia}
over	incl.	high	low	max.	max.	max.	max.	high	low	high	low	max.	max.
mm		μm		μm			μm	μm		μm		μm	μm
–	2,5	0	–8	10	8	6	6	0	–40	–	–	12	10
2,5	10	0	–8	10	8	6	6	0	–120	0	–250	15	10
10	18	0	–8	10	8	6	6	0	–120	0	–250	20	10
18	30	0	–10	13	10	8	8	0	–120	0	–250	20	13
30	50	0	–12	15	12	9	9	0	–120	0	–250	20	15
50	80	0	–15	19	19	11	11	0	–150	0	–380	25	20
80	120	0	–20	25	25	15	15	0	–200	0	–380	25	25
120	180	0	–25	31	31	19	19	0	–250	0	–500	30	30
180	250	0	–30	38	38	23	23	0	–300	0	–500	30	40
250	315	0	–35	44	44	26	26	0	–350	0	–500	35	50
315	400	0	–40	50	50	30	30	0	–400	0	–630	40	60
400	500	0	–45	56	56	34	34	0	–450	0	–630	50	65
500	630	0	–50	63	63	38	38	0	–500	0	–800	60	70
630	800	0	–75	–	–	–	–	0	–750	–	–	70	80
800	1 000	0	–100	–	–	–	–	0	–1 000	–	–	80	90
1 000	1 250	0	–125	–	–	–	–	0	–1 250	–	–	100	100
1 250	1 600	0	–160	–	–	–	–	0	–1 600	–	–	120	120
1 600	2 000	0	–200	–	–	–	–	0	–2 000	–	–	140	140

Outer ring

D		Δ_{Dmp}		$V_{Dp}^{2)}$ Diameter series 7, 8, 9 0, 1 2, 3, 4			Capped bearings ³⁾	$V_{Dmp}^{2)}$	$\Delta_{Cs}, \Delta_{C1s}, V_{Cs}$	K_{ea}
over	incl.	high	low	max.	max.	max.	max.	max.		max.
mm		μm		μm			μm	μm		μm
2,5	18	0	–8	10	8	6	10	6	Values are identical to those for the inner ring of the same bearing.	15
18	30	0	–9	12	9	7	12	7		15
30	50	0	–11	14	11	8	16	8		20
50	80	0	–13	16	13	10	20	10		25
80	120	0	–15	19	19	11	26	11		35
120	150	0	–18	23	23	14	30	14		40
150	180	0	–25	31	31	19	38	19		45
180	250	0	–30	38	38	23	–	23		50
250	315	0	–35	44	44	26	–	26		60
315	400	0	–40	50	50	30	–	30		70
400	500	0	–45	56	56	34	–	34		80
500	630	0	–50	63	63	38	–	38		100
630	800	0	–75	94	94	55	–	55		120
800	1 000	0	–100	125	125	75	–	75		140
1 000	1 250	0	–125	–	–	–	–	–		160
1 250	1 600	0	–160	–	–	–	–	–		190
1 600	2 000	0	–200	–	–	–	–	–		220
2 000	2 500	0	–250	–	–	–	–	–		250

¹⁾ Tolerances for tapered bores (→ table 11, page 145 and table 12, page 146).

²⁾ Applies to bearings prior to mounting with any snap rings removed.

³⁾ Applies only to bearings of diameter series 2 and 3.



Table 4

P6 class tolerances for radial bearings, except tapered roller bearings

Inner ring

d		$\Delta_{dmp}^{1)}$		V_{dp} Diameter series 7, 8, 9 0, 1 2, 3, 4			V_{dmp}	Δ_{Bs}		Δ_{B1s}		V_{Bs}	K_{ia}
over	incl.	high	low	max.	max.	max.	max.	high	low	high	low	max.	max.
mm		μm		μm			μm	μm		μm		μm	μm
-	2,5	0	-7	9	7	5	5	0	-40	-	-	12	5
2,5	10	0	-7	9	7	5	5	0	-120	0	-250	15	6
10	18	0	-7	9	7	5	5	0	-120	0	-250	20	7
18	30	0	-8	10	8	6	6	0	-120	0	-250	20	8
30	50	0	-10	13	10	8	8	0	-120	0	-250	20	10
50	80	0	-12	15	15	9	9	0	-150	0	-380	25	10
80	120	0	-15	19	19	11	11	0	-200	0	-380	25	13
120	180	0	-18	23	23	14	14	0	-250	0	-500	30	18
180	250	0	-22	28	28	17	17	0	-300	0	-500	30	20
250	315	0	-25	31	31	19	19	0	-350	0	-500	35	25
315	400	0	-30	38	38	23	23	0	-400	0	-630	40	30
400	500	0	-35	44	44	26	26	0	-450	0	-630	45	35
500	630	0	-40	50	50	30	30	0	-500	0	-800	50	40
630	800	0	-50	-	-	-	-	0	-750	-	-	55	45
800	1000	0	-60	-	-	-	-	0	-1000	-	-	60	50
1000	1250	0	-75	-	-	-	-	0	-1250	-	-	70	60
1250	1600	0	-90	-	-	-	-	0	-1600	-	-	70	70
1600	2000	0	-115	-	-	-	-	0	-2000	-	-	80	80

Outer ring

D		Δ_{Dmp}		V_{Dp} Diameter series 7, 8, 9 0, 1 2, 3, 4			Capped bearings ³⁾	$V_{Dmp}^{2)}$	$\Delta_{Cs}, \Delta_{C1s}, V_{Cs}$	K_{ea}
over	incl.	high	low	max.	max.	max.	max.	max.	max.	
mm		μm		μm			μm	μm	μm	
2,5	18	0	-7	9	7	5	9	5	Values are identical to those for the inner ring of the same bearing.	8
18	30	0	-8	10	8	6	10	6		9
30	50	0	-9	11	9	7	13	7		10
50	80	0	-11	14	11	8	16	8		13
80	120	0	-13	16	16	10	20	10		18
120	150	0	-15	19	19	11	25	11		20
150	180	0	-18	23	23	14	30	14		23
180	250	0	-20	25	25	15	-	15		25
250	315	0	-25	31	31	19	-	19		30
315	400	0	-28	35	35	21	-	21		35
400	500	0	-33	41	41	25	-	25		40
500	630	0	-38	48	48	29	-	29		50
630	800	0	-45	56	56	34	-	34		60
800	1000	0	-60	75	75	45	-	45		75
1000	1250	0	-75	-	-	-	-	-		85
1250	1600	0	-90	-	-	-	-	-		100
1600	2000	0	-115	-	-	-	-	-		100
2000	2500	0	-135	-	-	-	-	-		120

1) Tolerances for tapered bores (→ table 11, page 145).
 2) Applies to bearings prior to mounting with any snap rings removed.
 3) Applies only to bearings of diameter series 0, 1, 2 and 3.

Table 5

P5 class tolerances for radial bearings, except tapered roller bearings

Inner ring

d		Δ_{dmp}		V_{dp} Diameter series 7, 8, 9 0, 1, 2, 3, 4		V_{dmp}	Δ_{Bs}		Δ_{B1s}		V_{Bs}	K_{ia}	S_d	$S_{ia}^{1)}$
over	incl.	high	low	max.	max.	max.	high	low	high	low	max.	max.	max.	max.
mm		μm		μm		μm	μm		μm		μm	μm	μm	μm
–	2,5	0	–5	5	4	3	0	–40	0	–250	5	4	7	7
2,5	10	0	–5	5	4	3	0	–40	0	–250	5	4	7	7
10	18	0	–5	5	4	3	0	–80	0	–250	5	4	7	7
18	30	0	–6	6	5	3	0	–120	0	–250	5	4	8	8
30	50	0	–8	8	6	4	0	–120	0	–250	5	5	8	8
50	80	0	–9	9	7	5	0	–150	0	–250	6	5	8	8
80	120	0	–10	10	8	5	0	–200	0	–380	7	6	9	9
120	180	0	–13	13	10	7	0	–250	0	–380	8	8	10	10
180	250	0	–15	15	12	8	0	–300	0	–500	10	10	11	13
250	315	0	–18	18	14	9	0	–350	0	–500	13	13	13	15
315	400	0	–23	23	18	1	0	–400	0	–630	15	15	15	20
400	500	0	–28	28	21	1	0	–450	0	–630	18	17	18	23
500	630	0	–35	35	26	1	0	–500	0	–800	20	19	20	25
630	800	0	–45	–	–	–	0	–750	–	–	26	22	26	30
800	1 000	0	–60	–	–	–	0	–1 000	–	–	32	26	32	30
1 000	1 250	0	–75	–	–	–	0	–1 250	–	–	38	30	38	30
1 250	1 600	0	–90	–	–	–	0	–1 600	–	–	45	35	45	30
1 600	2 000	0	–115	–	–	–	0	–2 000	–	–	55	40	55	30

Outer ring

D		Δ_{Dmp}		V_{Dp} Diameter series 7, 8, 9 0, 1, 2, 3, 4		$V_{Dmp}^{2)}$	$\Delta_{Cs}, \Delta_{C1s}$	V_{Cs}	K_{ea}	S_D	$S_{ea}^{1)}$
over	incl.	high	low	max.	max.	max.		max.	max.	max.	max.
mm		μm		μm		μm		μm	μm	μm	μm
2,5	18	0	–5	5	4	3	Values are identical to those for the inner ring of the same bearing.	5	5	8	8
18	30	0	–6	6	5	3		5	6	8	8
30	50	0	–7	7	5	4		5	7	8	8
50	80	0	–9	9	7	5		6	8	8	10
80	120	0	–10	10	8	5		8	10	9	11
120	150	0	–11	11	8	6		8	11	10	13
150	180	0	–13	13	10	7		8	13	10	14
180	250	0	–15	15	11	8		10	15	11	15
250	315	0	–18	18	14	9		11	18	13	18
315	400	0	–20	20	15	10		13	20	13	20
400	500	0	–23	23	17	12		15	23	15	23
500	630	0	–28	28	21	14		18	25	18	25
630	800	0	–35	35	26	18		20	30	20	30
800	1 000	0	–50	50	29	25		25	35	25	35
1 000	1 250	0	–63	–	–	–		30	40	30	45
1 250	1 600	0	–80	–	–	–		35	45	35	55
1 600	2 000	0	–100	–	–	–		38	55	40	55
2 000	2 500	0	–125	–	–	–		45	65	50	55

1) Applies only to deep groove and angular contact ball bearings.

2) Does not apply to capped bearings.



Table 6

Normal and CL7C class tolerances for metric tapered roller bearings

Inner ring, bearing width and ring widths

d		Δ_{dmp}		V_{dp}	V_{dmp}	Δ_{Bs}		K_{ja}		Δ_{Ts}		Δ_{T1s}		Δ_{T2s}	
		over	incl.	high	low	max.	max.	high	low	Normal	CL7C	high	low	high	low
mm		μm		μm	μm	μm		μm		μm		μm		μm	
10	18	0	-12	12	9	0	-120	15	7	+200	0	+100	0	+100	0
18	30	0	-12	12	9	0	-120	18	8	+200	0	+100	0	+100	0
30	50	0	-12	12	9	0	-120	20	10	+200	0	+100	0	+100	0
50	80	0	-15	15	11	0	-150	25	10	+200	0	+100	0	+100	0
80	120	0	-20	20	15	0	-200	30	13	+200	-200	+100	-100	+100	-100
120	180	0	-25	25	19	0	-250	35	-	+350	-250	+150	-150	+200	-100
180	250	0	-30	30	23	0	-300	50	-	+350	-250	+150	-150	+200	-100
250	315	0	-35	35	26	0	-350	60	-	+350	-250	+150	-150	+200	-100
315	400	0	-40	40	30	0	-400	70	-	+400	-400	+200	-200	+200	-200

Outer ring

D		Δ_{Dmp}		V_{Dp}	V_{Dmp}	Δ_{Cs}	K_{ea}	
		over	incl.	high	low		max.	max.
mm		μm		μm	μm	μm		
18	30	0	-12	12	9	Values are identical to those for the inner ring of the same bearing.	18	9
30	50	0	-14	14	11		20	10
50	80	0	-16	16	12		25	13
80	120	0	-18	18	14		35	18
120	150	0	-20	20	15		40	20
150	180	0	-25	25	19		45	23
180	250	0	-30	30	23	50	-	
250	315	0	-35	35	26	60	-	
315	400	0	-40	40	30	70	-	
400	500	0	-45	45	34	80	-	
500	630	0	-50	60	38	100	-	
630	800	0	-75	80	55	120	-	

Table 7

CLN class tolerances for metric tapered roller bearings

Inner ring, bearing width and ring widths

d		Δ_{dmp}		V_{dp}	V_{dmp}	Δ_{Bs}		Δ_{Cs}		K_{ia}	Δ_{Ts}		Δ_{T1s}		Δ_{T2s}	
		over	incl.	high	low	max.	max.	high	low	high	low	max.	high	low	high	low
mm		μm		μm	μm	μm		μm		μm	μm		μm		μm	
10	18	0	-12	12	9	0	-50	0	-100	15	+100	0	+50	0	+50	0
18	30	0	-12	12	9	0	-50	0	-100	18	+100	0	+50	0	+50	0
30	50	0	-12	12	9	0	-50	0	-100	20	+100	0	+50	0	+50	0
50	80	0	-15	15	11	0	-50	0	-100	25	+100	0	+50	0	+50	0
80	120	0	-20	20	15	0	-50	0	-100	30	+100	0	+50	0	+50	0
120	180	0	-25	25	19	0	-50	0	-100	35	+150	0	+50	0	+100	0
180	250	0	-30	30	23	0	-50	0	-100	50	+150	0	+50	0	+100	0
250	315	0	-35	35	26	0	-50	0	-100	60	+200	0	+100	0	+100	0
315	400	0	-40	40	30	0	-50	0	-100	70	+200	0	+100	0	+100	0

Outer ring

D		Δ_{Dmp}		V_{Dp}	V_{Dmp}	K_{ea}
		over	incl.	high	low	max.
mm		μm		μm	μm	μm
18	30	0	-12	12	9	18
30	50	0	-14	14	11	20
50	80	0	-16	16	12	25
80	120	0	-18	18	14	35
120	150	0	-20	20	15	40
150	180	0	-25	25	19	45
180	250	0	-30	30	23	50
250	315	0	-35	35	26	60
315	400	0	-40	40	30	70
400	500	0	-45	45	34	80
500	630	0	-50	50	38	100

Table 8

P5 class tolerances for metric tapered roller bearings

Inner ring and bearing width

d		Δ_{dmp}		V_{dp}	V_{dmp}	Δ_{Bs}		K_{ia}	V_{dp}	Δ_{Ts}	
over	incl.	high	low	max.	max.	high	low	max.	max.	high	low
mm		μm		μm	μm	μm		μm	μm	μm	
10	18	0	-7	5	5	0	-200	5	7	+200	-200
18	30	0	-8	6	5	0	-200	5	8	+200	-200
30	50	0	-10	8	5	0	-240	6	8	+200	-200
50	80	0	-12	9	6	0	-300	7	8	+200	-200
80	120	0	-15	11	8	0	-400	8	9	+200	-200
120	180	0	-18	14	9	0	-500	11	10	+350	-250
180	250	0	-22	17	11	0	-600	13	11	+350	-250
250	315	0	-25	19	13	0	-700	16	13	+350	-250
315	400	0	-30	23	15	0	-800	19	15	+400	-400

Outer ring

D		Δ_{Dmp}		V_{Dp}	V_{Dmp}	Δ_{Cs}	K_{ea}	S_D
over	incl.	high	low	max.	max.		max.	max.
mm		μm		μm	μm		μm	μm
18	30	0	-8	6	5	Values are identical to those for the inner ring of the same bearing.	6	8
30	50	0	-9	7	5		7	8
50	80	0	-11	8	6		8	8
80	120	0	-13	10	7		10	9
120	150	0	-15	11	8		11	10
150	180	0	-18	14	9		13	10
180	250	0	-20	15	10		15	11
250	315	0	-25	19	13		18	13
315	400	0	-28	22	14		20	13
400	500	0	-33	25	17		23	15
500	630	0	-38	29	19		25	18

Table 9

Tolerances for inch tapered roller bearings

Inner ring

d		Δ_{ds} Tolerance classes			
over	incl.	Normal, CL2		CL3, CLO	
		high	low	high	low
mm		μm		μm	
-	76,2	+13	0	+13	0
76,2	101,6	+25	0	+13	0
101,6	266,7	+25	0	+13	0
266,7	304,8	+25	0	+13	0
304,8	609,6	+51	0	+25	0
609,6	914,4	+76	0	+38	0

Outer ring

D		Δ_{Ds} Tolerance classes				$K_{ia}, K_{ea}, S_{ia}, S_{ea}$ Tolerance classes			
over	incl.	Normal, CL2		CL3, CLO		Normal	CL2	CL3	CLO
		high	low	high	low	max.	max.	max.	max.
mm		μm		μm		μm			
-	304,8	+25	0	+13	0	51	38	8	4
304,8	609,6	+51	0	+25	0	51	38	18	9
609,6	914,4	+76	0	+38	0	76	51	51	26
914,4	1 219,2	+102	0	+51	0	76	-	76	38
1 219,2	-	+127	0	+76	0	76	-	76	-

Abutment width of single row bearing

d		D		Δ_{Fs} Tolerance classes					
over	incl.	over	incl.	Normal		CL2		CL3, CLO	
				high	low	high	low	high	low
mm		mm		μm		μm		μm	
-	101,6	-	-	+203	0	+203	0	+203	-203
101,6	266,7	-	-	+356	-254	+203	0	+203	-203
266,7	304,8	-	-	+356	-254	+203	0	+203	-203
304,8	609,6	-	508	+381	-381	+381	-381	+203	-203
304,8	609,6	-	508	+381	-381	+381	-381	+381	-381
609,6	-	-	-	+381	-381	-	-	+381	-381



Table 10

Tolerances for thrust bearings

Nominal diameter d, D		Shaft washer Tolerance classes Normal, P6, P5			Tolerance classes			Housing washer Tolerance classes Normal, P6, P5				S _e max.
over	incl.	Δ _{Dmp} high	low	V _{dp} max.	Normal S _i ⁽¹⁾ max.	P6 S _i ⁽¹⁾ max.	P5 S _i ⁽¹⁾ max.	Δ _{Dmp} high	low	V _{DP} max.		
mm		μm		μm	μm	μm	μm	μm		μm		
-	18	0	-8	6	10	5	3	0	-11	8	Values are identical to those for shaft washer of the same bearing.	
18	30	0	-10	8	10	5	3	0	-13	10		
30	50	0	-12	9	10	6	3	0	-16	12		
50	80	0	-15	11	10	7	4	0	-19	14		
80	120	0	-20	15	15	8	4	0	-22	17		
120	180	0	-25	19	15	9	5	0	-25	19		
180	250	0	-30	23	20	10	5	0	-30	23		
250	315	0	-35	26	25	13	7	0	-35	26		
315	400	0	-40	30	30	15	7	0	-40	30		
400	500	0	-45	34	30	18	9	0	-45	34		
500	630	0	-50	38	35	21	11	0	-50	38		
630	800	0	-75	55	40	25	13	0	-75	55		
800	1 000	0	-100	75	45	30	15	0	-100	75		
1 000	1 250	0	-125	95	50	35	18	0	-125	95		
1 250	1 600	0	-160	120	60	40	25	0	-160	120		
1 600	2 000	0	-200	150	75	-	-	0	-200	150		
2 000	2 500	0	-250	190	90	-	-	0	-250	190		

Bearing height

D		Δ _{Ts}		Δ _{T1s}		Δ _{T2s}		Δ _{T3s}		Δ _{T4s} ISO		SKF		SKF Explorer	
over	incl.	high	low	high	low	high	low	high	low	high	low	high	low	high	low
mm		μm		μm		μm		μm		μm					
-	30	+20	-250	+100	-250	+150	-400	+300	-400	-	-	-	-	-	-
30	50	+20	-250	+100	-250	+150	-400	+300	-400	-	-	-	-	-	-
50	80	+20	-300	+100	-300	+150	-500	+300	-500	+20	-300	0	-125	0	-100
80	120	+25	-300	+150	-300	+200	-500	+400	-500	+25	-300	0	-150	0	-100
120	180	+25	-400	+150	-400	+200	-600	+400	-600	+25	-400	0	-175	0	-125
180	250	+30	-400	+150	-400	+250	-600	+500	-600	+30	-400	0	-200	0	-125
250	315	+40	-400	-	-	-	-	-	-	+40	-400	0	-225	0	-150
315	400	+40	-500	-	-	-	-	-	-	+40	-500	0	-300	0	-200
400	500	+50	-500	-	-	-	-	-	-	+50	-500	0	-420	-	-
500	630	+60	-600	-	-	-	-	-	-	+60	-600	0	-500	-	-
630	800	+70	-750	-	-	-	-	-	-	+70	-750	0	-630	-	-
800	1 000	+80	-1 000	-	-	-	-	-	-	+80	-1 000	0	-800	-	-
1 000	1 250	+100	-1 400	-	-	-	-	-	-	+100	-1 400	0	-1 000	-	-
1 250	1 600	+120	-1 600	-	-	-	-	-	-	+120	-1 600	0	-1 200	-	-

¹⁾ Does not apply to spherical roller thrust bearings.

Table 11

Normal, P6 and P5 class tolerances for tapered bores, taper 1:12

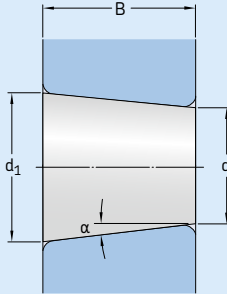

Half angle of taper 1:12

$$\alpha = 2^\circ 23' 9,4''$$

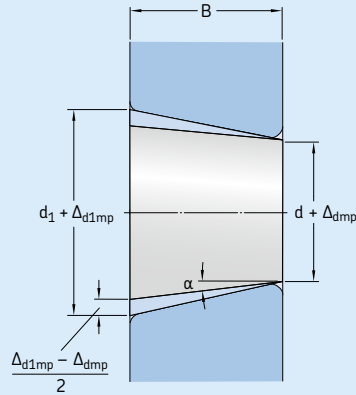
Largest theoretical diameter d_1

$$d_1 = d + \frac{1}{12} B$$

Bore diameter		Tolerance classes			P5		P6		Tolerance classes		
d		Normal, P6			Δ_{dmp}		$V_{dp}^{1)}$		$\Delta_{d1mp} - \Delta_{dmp}$		
over	incl.	high	low	max.	high	low	high	low	max.	high	low
mm		μm		μm	μm		μm		μm		
18	30	+21	0	13	+21	0	+13	0	13	+13	0
30	50	+25	0	15	+25	0	+16	0	15	+16	0
50	80	+30	0	19	+30	0	+19	0	19	+19	0
80	120	+35	0	25	+35	0	+22	0	22	+22	0
120	180	+40	0	31	+40	0	+25	0	25	+25	0
180	250	+46	0	38	+46	0	+29	0	29	+29	0
250	315	+52	0	44	+52	0	+32	0	32	+32	0
315	400	+57	0	50	+57	0	+36	0	36	+36	0
400	500	+63	0	56	+63	0	+40	0	–	+40	0
500	630	+70	0	70	+70	0	+44	0	–	+44	0
630	800	+80	0	–	+80	0	+50	0	–	+50	0
800	1 000	+90	0	–	+90	0	+56	0	–	+56	0
1 000	1 250	+105	0	–	+105	0	+66	0	–	+66	0
1 250	1 600	+125	0	–	+125	0	+78	0	–	+78	0
1 600	2 000	+150	0	–	+150	0	+92	0	–	+92	0

¹⁾ Applies to any single radial plane of the bore.

Table 12

Normal tolerances for tapered bores, taper 1:30

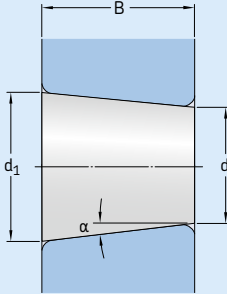

Half angle of taper 1:30
 $\alpha = 0^\circ 57' 17,4''$

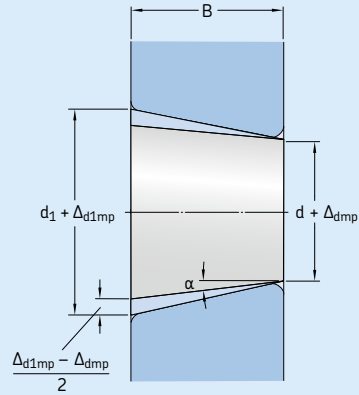

Largest theoretical diameter d_1
 $d_1 = d + \frac{1}{30} B$

Bore diameter		Tolerance class		$V_{dp}^{1)}$	$\Delta_{d1mp} - \Delta_{dmp}$	
d		Normal			high	low
over	incl.	Δ_{dmp}		max.	high	low
mm		μm		μm	μm	
-	80	+15	0	19	+30	0
80	120	+20	0	22	+35	0
120	180	+25	0	40	+40	0
180	250	+30	0	46	+46	0
250	315	+35	0	52	+52	0
315	400	+40	0	57	+57	0
400	500	+45	0	63	+63	0
500	630	+50	0	70	+70	0
630	800	+75	0	-	+100	0
800	1 000	+100	0	-	+100	0
1 000	1 250	+125	0	-	+115	0
1 250	1 600	+160	0	-	+125	0
1 600	2 000	+200	0	-	+150	0

¹⁾ Applies to any single plane of the bore.

Table 13

Chamfer dimension limits for metric radial and thrust bearings, except tapered roller bearings

Minimum single chamfer dimension	Nominal bearing bore diameter		Maximum chamfer dimensions		
	$r_{s \text{ min}}$	d over incl.	$r_{1,3 \text{ max.}}$	$r_{2,4 \text{ max.}}$	$r_{1,2,3,4 \text{ max.}}$
mm	mm		mm		
0,05	-	-	0,1	0,2	0,1
0,08	-	-	0,16	0,3	0,16
0,1	-	-	0,2	0,4	0,2
0,15	-	-	0,3	0,6	0,3
0,2	-	-	0,5	0,8	0,5
0,3	-	40	0,6	1	0,8
	40	-	0,8	1	0,8
0,6	-	40	1	2	1,5
	40	-	1,3	2	1,5
1	-	50	1,5	3	2,2
	50	-	1,9	3	2,2
1,1	-	120	2	3,5	2,7
	120	-	2,5	4	2,7
1,5	-	120	2,3	4	3,5
	120	-	3	5	3,5
2	-	80	3	4,5	4
	80	220	3,5	5	4
	220	-	3,8	6	4
2,1	-	280	4	6,5	4,5
	280	-	4,5	7	4,5
2,5	-	100	3,8	6	-
	100	280	4,5	6	-
	280	-	5	7	-
3	-	280	5	8	5,5
	280	-	5,5	8	5,5
4	-	-	6,5	9	6,5
5	-	-	8	10	8
6	-	-	10	13	10
7,5	-	-	12,5	17	12,5
9,5	-	-	15	19	15
12	-	-	18	24	18

Table 14

Chamfer dimension limits for metric radial tapered roller bearings

Minimum single chamfer dimension	Nominal bearing bore/outside diameter		Maximum chamfer dimensions	
	$r_{s \text{ min}}$	d, D over incl.	$r_{1,3 \text{ max.}}$	$r_{2,4 \text{ max.}}$
mm	mm		mm	
0,3	-	40	0,7	1,4
	40	-	0,9	1,6
0,5	-	40	1,1	1,7
	40	-	1,2	1,9
0,6	-	40	1,1	1,7
	40	-	1,3	2
1	-	50	1,6	2,5
	50	-	1,9	3
1,5	-	120	2,3	3
	120	250	2,8	3,5
	250	-	3,5	4
2	-	120	2,8	4
	120	250	3,5	4,5
	250	-	4	5
2,5	-	120	3,5	5
	120	250	4	5,5
	250	-	4,5	6
3	-	120	4	5,5
	120	250	4,5	6,5
	250	400	5	7
	400	-	5,5	7,5
4	-	120	5	7
	120	250	5,5	7,5
	250	400	6	8
	400	-	6,5	8,5
5	-	180	6,5	8
	180	-	7,5	9
6	-	180	7,5	10
	180	-	9	11

E

Table 15

Chamfer dimension limits for inch tapered roller bearings

Minimum single chamfer dimension		Inner ring				Outer ring					
		Nominal bearing bore diameter		Maximum chamfer dimensions		Nominal bearing outside diameter		Maximum chamfer dimensions			
		r_s min over	incl.	d over	incl.	r_1 max.	r_2 max.	D over	incl.	r_3 max.	r_4 max.
mm		mm		mm		mm		mm		mm	
0,6	1,4	–	101,6	r_1 min + 0,5	r_2 min + 1,3	–	168,3	r_3 min + 0,6	r_4 min + 1,2		
		101,6	254	r_1 min + 0,6	r_2 min + 1,8	168,3	266,7	r_3 min + 0,8	r_4 min + 1,4		
		254	–	r_1 min + 0,9	r_2 min + 2	266,7	355,6	r_3 min + 1,7	r_4 min + 1,7		
								r_3 min + 0,9	r_4 min + 2		
1,4	2,5	–	101,6	r_1 min + 0,5	r_2 min + 1,3	–	168,3	r_3 min + 0,6	r_4 min + 1,2		
		101,6	254	r_1 min + 0,6	r_2 min + 1,8	168,3	266,7	r_3 min + 0,8	r_4 min + 1,4		
		254	–	r_1 min + 2	r_2 min + 3	266,7	355,6	r_3 min + 1,7	r_4 min + 1,7		
								r_3 min + 2	r_4 min + 3		
2,5	4,0	–	101,6	r_1 min + 0,5	r_2 min + 1,3	–	168,3	r_3 min + 0,6	r_4 min + 1,2		
		101,6	254	r_1 min + 0,6	r_2 min + 1,8	168,3	266,7	r_3 min + 0,8	r_4 min + 1,4		
		254	400	r_1 min + 2	r_2 min + 4	266,7	355,6	r_3 min + 1,7	r_4 min + 1,7		
								r_3 min + 2	r_4 min + 4		
								r_3 min + 2,5	r_4 min + 4,5		
4,0	5,0	–	101,6	r_1 min + 0,5	r_2 min + 1,3	–	168,3	r_3 min + 0,6	r_4 min + 1,2		
		101,6	254	r_1 min + 0,6	r_2 min + 1,8	168,3	266,7	r_3 min + 0,8	r_4 min + 1,4		
		254	–	r_1 min + 2,5	r_2 min + 4	266,7	355,6	r_3 min + 1,7	r_4 min + 1,7		
								r_3 min + 2,5	r_4 min + 4		
5,0	6,0	–	101,6	r_1 min + 0,5	r_2 min + 1,3	–	168,3	r_3 min + 0,6	r_4 min + 1,2		
		101,6	254	r_1 min + 0,6	r_2 min + 1,8	168,3	266,7	r_3 min + 0,8	r_4 min + 1,4		
		254	–	r_1 min + 3	r_2 min + 5	266,7	355,6	r_3 min + 1,7	r_4 min + 1,7		
								r_3 min + 3	r_4 min + 5		
6,0	7,5	–	101,6	r_1 min + 0,5	r_2 min + 1,3	–	168,3	r_3 min + 0,6	r_4 min + 1,2		
		101,6	254	r_1 min + 0,6	r_2 min + 1,8	168,3	266,7	r_3 min + 0,8	r_4 min + 1,4		
		254	–	r_1 min + 4,5	r_2 min + 6,5	266,7	355,6	r_3 min + 1,7	r_4 min + 1,7		
								r_3 min + 4,5	r_4 min + 6,5		
7,5	9,5	–	101,6	r_1 min + 0,5	r_2 min + 1,3	–	168,3	r_3 min + 0,6	r_4 min + 1,2		
		101,6	254	r_1 min + 0,6	r_2 min + 1,8	168,3	266,7	r_3 min + 0,8	r_4 min + 1,4		
		254	–	r_1 min + 6,5	r_2 min + 9,5	266,7	355,6	r_3 min + 1,7	r_4 min + 1,7		
								r_3 min + 6,5	r_4 min + 9,5		
9,5	12	–	101,6	r_1 min + 0,5	r_2 min + 1,3	–	168,3	r_3 min + 0,6	r_4 min + 1,2		
		101,6	254	r_1 min + 0,6	r_2 min + 1,8	168,3	266,7	r_3 min + 0,8	r_4 min + 1,4		
		254	–	r_1 min + 8	r_2 min + 11	266,7	355,6	r_3 min + 1,7	r_4 min + 1,7		
								r_3 min + 8	r_4 min + 11		

Bearing internal clearance

Bearing internal clearance (→ **fig. 3**) is defined as the total distance through which one bearing ring can be moved relative to the other in the radial direction (radial internal clearance) or in the axial direction (axial internal clearance).

It is necessary to distinguish between initial internal clearance in the bearing prior to mounting and operating internal clearance, which applies to a bearing in operation that has reached a stable temperature.

In almost all applications, the initial clearance in a bearing is greater than its operating clearance. The difference can be attributed to the need for an interference fit on the shaft and/or in the housing, combined with thermal expansion of the bearing rings and associated components.

Sufficient internal clearance in a bearing during operation is extremely important if the bearing is to operate satisfactorily. As a general rule, ball bearings should have an operating clearance (or preload) that is virtually zero. Cylindrical, needle, spherical and CARB toroidal roller bearings, on the other hand, should always have some residual (radial) clearance – however small – in operation. The same is true for tapered roller and angular contact ball bearings. However, in applications where a high degree of stiffness is required, tapered roller and angular contact ball bearings can be mounted with a certain amount of preload (→ *Bearing preload*, **page 214**).

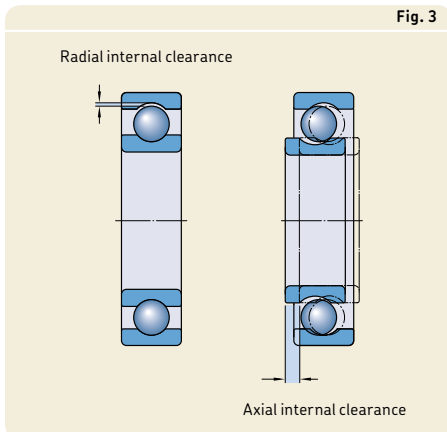

E

The initial internal clearance referred to as Normal implies that a suitable operating clearance can be obtained if the recommended shaft and housing fits are realized during mounting and operating conditions are normal. Where operating and mounting conditions differ from normal, for example, when interference fits are used for both bearing rings or considerable temperature differences prevail, bearings with greater or smaller internal clearance than Normal are required. In these cases, SKF recommends checking residual (radial) clearance in the bearing after it has been mounted.

Bearings with an internal clearance other than Normal are identified by the suffixes C1 to C5 (→ **table 16**).

The clearance values for the various bearing types are listed in the relevant product chapters and are valid for unmounted bearings. For paired (universally matchable) single row angular contact ball bearings and tapered roller bearings, double row angular contact ball bearings and four-point contact ball bearings, values for the axial internal clearance are listed instead of radial clearance, as the axial clearance is of greater importance for these bearing types.

For additional information about clearance or preload, refer to *Selecting internal clearance or preload* (→ **page 212**).

Materials for rolling bearings

The materials from which bearing components are made, determine, to a large extent, the performance and reliability of the bearing. For the bearing rings and rolling elements, typical considerations include hardness for load carrying capacity, fatigue resistance in the rolling contact area, under clean or contaminated lubrication conditions, and the dimensional stability of the bearing components. For the cage, considerations include friction, strain, inertial forces, and in some cases, the chemical action of certain lubricant additives, solvents, coolants and refrigerants. The relative importance of these considerations can be affected by other operational parameters including moisture, elevated temperatures, shock loads or a combination of these and other conditions.

Rolling bearings with integral contact seals can also have a considerable impact on the performance and reliability of the bearings. Their materials must be able to resist heat, chemicals and oxidation. Bearings that are capped on both sides normally are lubricated for life. For detailed information about lubrication and lubricants, refer to *Lubrication* (→ **page 239**).

SKF has the competence and facilities to provide a variety of materials, processes and coatings. Therefore, SKF application engineers can assist in selecting materials that can provide superior performance for a particular application.

Table 16

Supplementary designation for internal clearance

Suffix	Internal clearance
C1	Smaller than C2
C2	Smaller than Normal
CN	Normal, only used together with an additional letter that identifies a reduced or displaced clearance range.
C3	Greater than Normal
C4	Greater than C3
C5	Greater than C4

Materials for bearing rings and rolling elements

Bearing steels for through-hardening

The most common steel for through-hardening is a carbon chromium steel, containing approximately 1% carbon and 1,5% chromium, in accordance with ISO 683-17. Today, carbon-chromium steel is one of the oldest and most intensively investigated steels due to the continuously increasing demands for extended bearing service life. The composition of this bearing steel provides an optimum balance between manufacturing and application performance. This steel normally undergoes a martensitic or bainitic heat treatment to obtain a hardness between 58 and 65 HRC.

Within the last few years, process developments have enabled more stringent cleanliness specifications to be realized, which has had a significant impact on the consistency and quality of SKF's bearing steel. The reduction of oxygen and harmful non-metallic inclusions has led to significantly improved properties of rolling bearing steels – the steels from which SKF Explorer bearings are made.

Bearing steels for induction-hardening

Surface induction-hardening offers the possibility to selectively harden a component's raceway, while leaving the remainder of the component unaffected by the hardening process. The steel grade and the manufacturing processes used prior to surface induction-hardening dictate the properties in the unaffected areas, which means that a combination of properties can be achieved in one component.

An example of this is the flanged wheel hub bearing unit (HBU), where the properties of the unhardened flange must resist structural fatigue, while the raceways are hardened to resist rolling contact fatigue.

Bearing steels for case-hardening

Chromium-nickel and manganese-chromium alloyed steels in accordance with ISO 683-17 with a carbon content of approximately 0,15% are the steels most commonly used for case-hardened SKF rolling bearing components.

In applications where there are high tensile interference fits and heavy shock loads, SKF recommends bearings with case-hardened rings and/or rolling elements.

Stainless steels

The most common stainless steels used for SKF bearing rings and rolling elements are high chromium content steels like X65Cr14 in accordance with ISO 683-17 and X105CrMo17 in accordance with EN 10088-1.

It should be noted that for some applications, corrosion resistant coatings might be an excellent alternative to stainless steel. For additional information about alternative coatings, contact the SKF application engineering service.

High-temperature bearing steels

Depending on the bearing type, standard bearings made of steels for through-hardening and surface-hardening have a recommended maximum operating temperature, which ranges between 120 and 200 °C (250 to 390 °F). The maximum operating temperature is directly related to the heat treat process.

For operating temperatures up to 250 °C (480 °F), a special heat treat (stabilization) process can be applied. In this case, however, the process reduces the load carrying capacity of the bearing, which must be taken into consideration.

For bearings operating at elevated temperatures above 250 °C (480 °F) for extended periods, highly alloyed steels like 80MoCrV42-16, manufactured in accordance with ISO 683-17, should be used. This steel, which retains its hardness, enables the bearing to maintain its performance characteristics even under extreme temperature conditions.

For additional information about high-temperature bearing steels, contact the SKF application engineering service.

Bearing specifics

Ceramics

The common ceramic used for SKF bearing rings and rolling elements is a bearing grade silicon nitride material in accordance with ISO 26602. It consists of fine elongated grains of beta-silicon nitride in a glassy phase matrix. It provides a combination of favourable properties for rolling bearings, such as high hardness, low density, low coefficient of thermal expansion, high electric resistivity, low dielectric constant and no response to magnetic fields (→ **table 17**).

Cage materials

Stamped metal cages

Sheet steel cages

The majority of stamped sheet steel cages are made of continuously hot-rolled low carbon steel in accordance with EN 10111. These lightweight cages have relatively high strength and can be surface treated to further reduce friction and wear.

Stamped cages normally used in stainless steel bearings are made of X5CrNi18-10 stainless steel, in accordance with EN 10088-1.

Sheet brass cages

Stamped sheet brass cages are used for some small and medium-size bearings. The brass used for these cages is in accordance with EN 1652. In applications like refrigeration compressors that use ammonia, season cracking in sheet brass might occur, therefore machined brass or steel cages should be used instead.

Table 17

Comparison of the material properties of bearing steel and bearing grade silicon nitride

Material properties	Bearing steel	Bearing grade silicon nitride
Mechanical properties		
Density [g/cm ³]	7,9	3,2
Hardness	700 HV10	1 600 HV10
Modulus of elasticity [kN/mm ²]	210	310
Thermal expansion [10 ⁻⁶ /K]	12	3
Electrical properties (at 1 MHz)		
Electrical resistivity [Ωm]	0,4 × 10 ⁻⁶ (Conductor)	10 ¹² (Insulator)
Dielectric strength [kV/mm]	–	15
Relative dielectric constant	–	8

Machined metal cages

Machined steel cages

Machined steel cages are normally made of non-alloyed structural S355GT (St 52) type steel in accordance with EN 10 025:1990 + A:1993. To improve sliding and wear-resistance properties, some machined steel cages are surface treated.

Machined steel cages are used for large bearings or in applications where there is a danger that season cracking, caused by a chemical reaction, may occur if a brass cage is used. Steel cages can be used at operating temperatures up to 300 °C (570 °F). They are not affected by the mineral or synthetic oil-based lubricants normally used for rolling bearings, or by the organic solvents used to clean bearings.

Machined brass cages

Most brass cages are machined from a CW612N cast or wrought brass in accordance with EN 1652. They are unaffected by most common bearing lubricants, including synthetic oils and greases, and can be cleaned using normal organic solvents. Brass cages should not be used at temperatures above 250 °C (480 °F).

Polymer cages

Polyamide 66

For the majority of injection moulded cages, polyamide 66 (PA66) is used. This material, with or without glass fibres, is characterized by a favourable combination of strength and elasticity. The mechanical properties like strength and elasticity of polymer materials are temperature dependent and subject to ageing. The most important factors that play a role in the ageing process are temperature, time and the medium (lubricant) to which the polymer is exposed. **Diagram 1** shows the relationship between these factors for glass fibre reinforced PA66. It shows that cage life decreases with increasing temperature and the aggressiveness of the lubricant.

Diagram 1

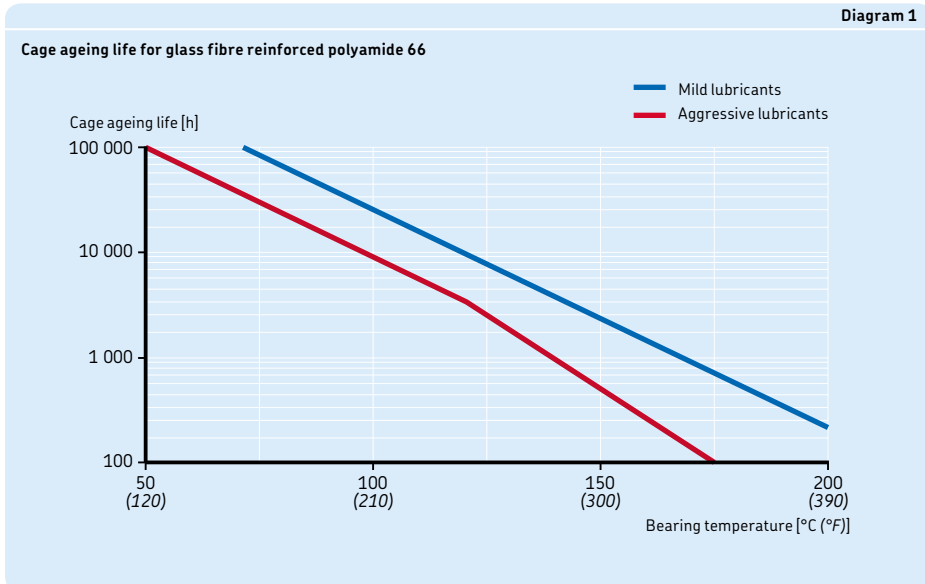

E

Bearing specifics

Therefore, whether polyamide cages are suitable for a specific application depends on the operating conditions and life requirements. The classification of lubricants into “aggressive” and “mild” is reflected by the “permissible operating temperature” for cages made of glass fibre reinforced PA66 with various lubricants (→ **table 18**). The permissible operating temperature in **table 18** is defined as the temperature that provides a cage ageing life of at least 10 000 operating hours.

Some media are even more “aggressive” than those provided in **table 18**. A typical example is ammonia, used as a refrigerant in compressors. In those cases, cages made of glass fibre reinforced PA66 should not be used at operating temperatures above 70 °C (160 °F).

Polyamide also has a low temperature limit because it loses its elasticity, which can cause cage failures under extremely cold conditions. As a result, cages made of glass fibre reinforced PA66 should not be used in applications where

the continuous operating temperature is below –40 °C (–40 °F).

In applications where a high degree of toughness is a critical operational parameter, such as in railway axleboxes, a super-tough modified PA66 can be used. For additional information, contact the SKF application engineering service.

Table 18

Permissible operating temperatures for PA66 cages with various bearing lubricants

Lubricant	Permissible operating temperature ¹⁾	
	°C	°F
–		
Mineral oils		
Oils without EP additives, e.g. machine or hydraulic oils	120	250
Oils with EP additives, e.g. industrial and automotive gearbox oils	110	230
Oils with EP additives, e.g. automotive rear axle and differential gear oils (automotive), hypoid gear oils	100	210
Synthetic oils		
Polyglycols, poly- α -olefins	120	250
Diesters, silicones	110	230
Phosphate esters	80	175
Greases		
Lithium greases	120	250
Polyurea, bentonite, calcium complex greases	120	250

For sodium and calcium greases and other greases with a maximum operating temperature ≤ 120 °C (250 °F), the maximum temperature for a polyamide cage is the same as the maximum operating temperature for the grease.

¹⁾ Measured on the outside surface of the outer ring; defined as the temperature that provides a cage ageing life of at least 10 000 operating hours.

Polyamide 46

Glass fibre reinforced polyamide 46 (PA46) is the standard cage material for some small and medium-size CARB toroidal roller bearings. The permissible operating temperature is 15 °C (25 °F) higher than for glass fibre reinforced PA66.

Polyetheretherketone

The use of the glass fibre reinforced polyetheretherketone (PEEK) has become more popular for demanding conditions regarding high speeds, chemical resistance or high temperatures. The exceptional properties of PEEK provide a superior combination of strength and flexibility, high operating temperature range, high chemical and wear-resistance and good processability. Due to these outstanding features, PEEK cages are available as standard for some ball and cylindrical roller bearings, such as hybrid and/or super-precision bearings. The material does not show signs of ageing by temperature or oil additives up to 200 °C (390 °F). However, the maximum temperature for high-speed use is limited to 150 °C (300 °F) as this is the softening temperature of the polymer.

Phenolic resin

Lightweight, fabric reinforced phenolic resin cages can withstand heavy inertial forces, but are not able to accommodate high operating temperatures. In most cases, these cages are used as standard in super-precision angular contact ball bearings.

Cages made of other materials

In addition to the materials described above, SKF bearings for special applications may be fitted with cages made of other engineered polymers, light alloys or special cast iron. For additional information about alternative cage materials, contact the SKF application engineering service.

Seal materials

Seals integrated in SKF bearings are typically made of elastomers. The type of material can depend on the series and size of the bearing as well as the application requirements. SKF seals are generally made of the materials listed below.

Acrylonitrile-butadiene rubber

Acrylonitrile-butadiene rubber (NBR) is the “universal” seal material. This copolymer, manufactured from acrylonitrile and butadiene, has good resistance to the following media:

- most mineral oils and greases with a mineral oil base
- normal fuels, such as petrol, diesel and light heating oils
- animal and vegetable oils and fats
- hot water

It also can tolerate dry running of the lip for short periods. The permissible operating temperature range is –40 to +100 °C (–40 to +210 °F). Temperatures up to 120 °C (250 °F) can be tolerated for brief periods. At higher temperatures, the material hardens.

E

Hydrogenated acrylonitrile-butadiene rubber

Hydrogenated acrylonitrile-butadiene rubber (HNBR) has appreciably better wear-characteristics than NBR so that seals made of this material have a longer service life. HNBR is also more resistant to heat, ageing and hardening in hot oil or ozone exposure.

The upper operating temperature limit is 150 °C (300 °F), which is appreciably higher than that of NBR.

Fluoro rubber

Fluoro rubbers (FKM) are characterized by their high thermal and chemical resistance. Their resistance to ageing and ozone is very good and their gas permeability is very slight. They have exceptionally good wear-characteristics even under harsh environmental conditions and can withstand operating temperatures up to 200 °C (390 °F). Seals made of this material can tolerate dry running of the lip for short periods.

FKM is also resistant to oils and hydraulic fluids, fuels and lubricants, mineral acids and aliphatic as well as aromatic hydrocarbons which would cause seals made of other materials to fail. In the presence of esters, ethers, ketones, certain amines and hot anhydrous hydrofluorides, FKM should not be used.

Seals made of FKM exposed to an open flame or temperatures above 300 °C (570 °F) are a health and environmental hazard! They remain dangerous even after they have cooled. Read and follow the safety precautions (→ **WARNING**).

WARNING

Safety precautions for fluoro rubber and Polytetrafluoroethylene

Fluoro rubber (FKM) and Polytetrafluoroethylene (PTFE) are very stable and harmless under normal operating conditions up to 200 °C (390 °F). However, if exposed to extreme temperatures above 300 °C (570 °F), such as fire or the open flame of a cutting torch, FKM and PTFE give off hazardous fumes. These fumes can be harmful if inhaled, as well as if they contact the eyes. In addition, once the seals have been heated to such temperatures, they are dangerous to handle even after they have cooled. Therefore, they should never come in contact with the skin. If it is necessary to handle bearings with seals that have been subjected to high temperatures, such as when dismounting the bearing, the following safety precautions should be observed:

- Always wear protective goggles, gloves and an appropriate breathing apparatus.
- Place the remains of the seals in an airtight plastic container marked with a symbol for “material will etch”.
- Follow the safety precautions in the appropriate material safety data sheet (MSDS).

If there is unintentional contact with the seals, wash hands with soap and plenty of water and flush eyes with plenty of water and consult a doctor immediately. If the fumes have been inhaled, consult a doctor immediately.

The user is responsible for the correct use of the product during its service life and its proper disposal. SKF takes no responsibility for the improper handling of FKM or PTFE, or for any injury resulting from their use.

Polyurethane

Polyurethane (PUR) is a wear-resistant organic material which has good elastic properties. It withstands operating temperatures from -20 up to $+80$ °C (-5 to 175 °F). It has good resistance to mineral oil-based greases, mineral oils with no or a low proportion of EP additives, water and water-oil mixtures. It is not resistant to acids, alkalis or polar solvents.

Lubricants

Capped bearings normally have a factory grease fill. The lubricant is an integral part of the bearing. For additional information, refer to the relevant product chapter.

Coatings

Coating is a well-established method to upgrade materials and to provide bearings with additional benefits for specific application conditions. Two different coating methods developed by SKF are available and have been proven successful in many applications.

NoWear is a wear-resistant surface coating that applies a low-friction carbon coating on the bearing inner ring raceway(s) and/or the rolling elements. It can withstand long periods of operation under marginal lubrication conditions. For additional information, refer to *NoWear coated bearings* (→ **page 1241**).

INSOCOAT bearings are standard bearings that have the external surfaces of their inner or outer ring plasma-sprayed with an aluminium oxide to form a coating. It offers resistance to the damage that can be caused by the passage of stray electric current through the bearing. For additional information, refer to *INSOCOAT bearings* (→ **page 1205**).

Other coatings like zinc chromate, for example, can offer an alternative to stainless steel bearings in a corrosive environment, especially for ready-to-mount bearing units.

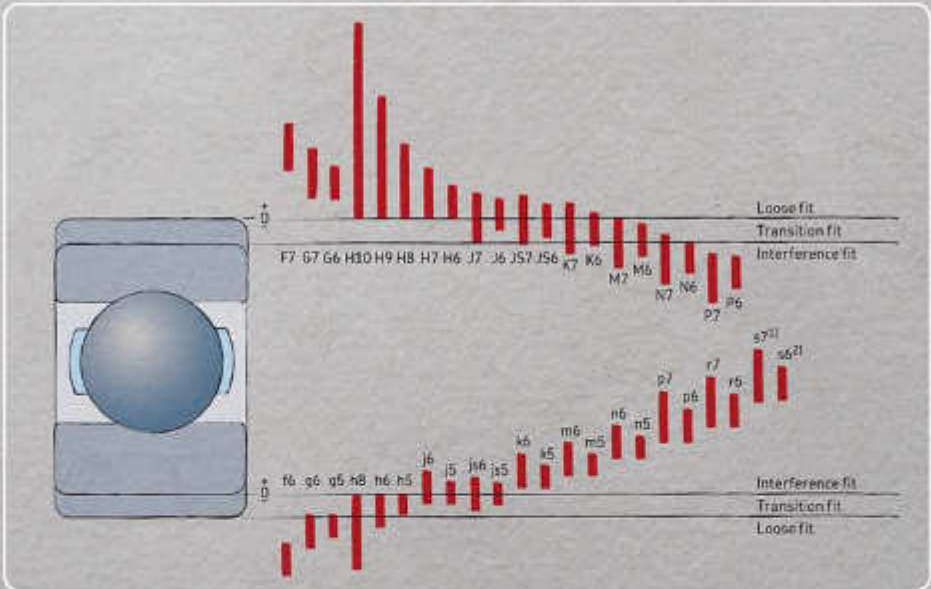

Design considerations

Bearing systems	160	Bearing clearance	213
Locating/non-locating bearing system ..	160	Selecting a clearance class	213
Adjusted bearing system	163	Bearing preload	214
Floating bearing system	164	Considerations for preload	215
		Effects of bearing preload	217
		Preload in bearing systems with	
		angular contact ball or tapered	
		roller bearings	218
Radial location of bearings	165	Adjustment procedures	221
Selecting fits	165	Individual adjustment	221
Bearings with a tapered bore	169	Collective adjustment	224
Recommended fits	169	Preloading with springs	224
Shaft and housing tolerances and fits ..	171	Selecting the correct preload	225
Fits for hollow shafts	176	Bearings for preloaded	
Dimensional and geometrical tolerances		bearing systems	225
of bearing seats and abutments	200		
Dimensional tolerances	200	Sealing solutions	226
Tolerances for total radial run-out ..	200	Seal types	226
Tolerances for total axial run-out ..	200	Selecting seal type	227
Tolerances for tapered shaft seats ..	202	Non-contact seals	228
Surface roughness of bearing seats ...	204	Contact seals	228
		Integral bearing seals	229
Axial location of bearings	204	Bearings with shields	229
Locating methods	205	Bearings with contact seals	229
Bearings with a cylindrical bore	205	External seals	231
Bearings with a tapered bore	207	Non-contact seals	231
Abutment and fillet dimensions	208	Contact seals	234
CARB toroidal roller bearings	209		
Design of associated components	210		
Raceways on shafts and in housings	210		
Provisions for mounting and			
dismounting	210		
Selecting internal clearance or			
preload	212		
Clearance versus preload	213		



Bearing systems

A bearing system, which is typically used to support a rotating shaft, generally requires two bearing arrangements – one at each end of the shaft. Depending on the requirements, such as stiffness or load directions, a bearing arrangement consists of one or more (matched) bearings. Typically, the purpose of a bearing system is to support and locate the shaft radially and axially, relative to stationary components, like housings. Depending on the application, loads, requisite running accuracy and cost considerations, various bearing systems can be designed:

- a locating/non-locating bearing system
- an adjusted bearing system
- a floating bearing system

Bearing systems consisting of a single bearing that can support radial, axial and moment loads, e.g. for an articulated joint, are not covered in this catalogue. For information about these bearing systems, contact the SKF application engineering service.

Locating/non-locating bearing system

A locating/non-locating bearing system in a typical industrial application is designed to accommodate thermal expansion and contraction of a shaft. In this system, the bearing arrangement at one end of the shaft must be able to locate the shaft axially. This is accomplished by securing one bearing axially on the shaft and in the housing. The bearing arrangement on the opposite end of the shaft is non-locating and is designed to accommodate thermal displacements of the shaft relative to the housing to avoid induced internal loads.

For the locating bearing position, radial bearings that can accommodate combined (radial and axial) loads are used. These include deep groove ball bearings, double row or matched single row angular contact ball bearings, self-aligning ball bearings, spherical roller bearings, matched tapered roller bearings, NUP design cylindrical roller bearings, or NJ design cylindrical roller bearings mounted with an HJ angle ring.

Alternatively, the bearing arrangement in the locating position can consist of a combination of two bearings:

- A radial bearing that only accommodates radial load, such as a cylindrical roller bearing that has one ring without flanges.
- A bearing that provides axial location, such as a deep groove ball bearing, a four-point contact ball bearing, or a double direction thrust bearing.

The bearing that locates the shaft axially must not be located radially and is typically mounted with a small radial gap in the housing.

There are two ways to accommodate thermal displacements of the shaft at the non-

Fig. 1

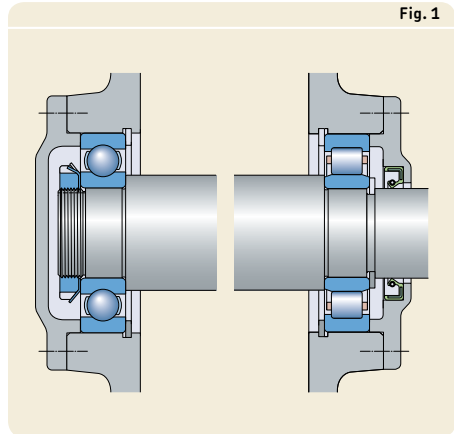
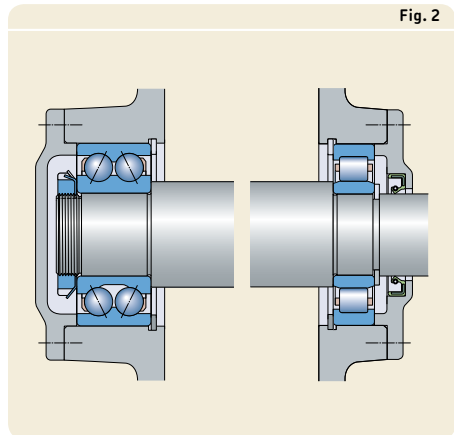

Fig. 2



locating bearing position. The first is to use a bearing that only accommodates radial loads and enables axial displacement within the bearing. These include CARB toroidal roller bearings, needle roller bearings and cylindrical roller bearings that have one ring without flanges. The other method is to use a radial bearing mounted with a small radial gap in the housing so that the outer ring is free to move axially.

From the large number of locating/non-locating bearing combinations, the popular ones are listed in the following.

For stiff bearing arrangements requiring “frictionless” axial displacement within a bearing, the following combinations should be considered:

- deep groove ball bearing / cylindrical roller bearing (→ **fig. 1**)
- double row angular contact ball bearing / NU or N design cylindrical roller bearing (→ **fig. 2**)
- matched single row tapered roller bearings / NU or N design cylindrical roller bearing (→ **fig. 3**)
- NUP design cylindrical roller bearing / NU design cylindrical roller bearing (→ **fig. 4**)
- NU design cylindrical roller bearing and a four-point contact ball bearing / NU design cylindrical roller bearing (→ **fig. 5**)

Fig. 3

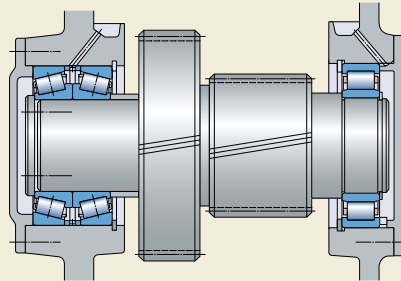

Fig. 4

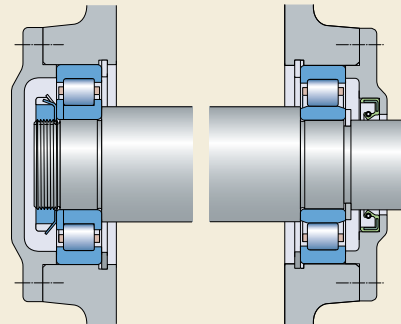
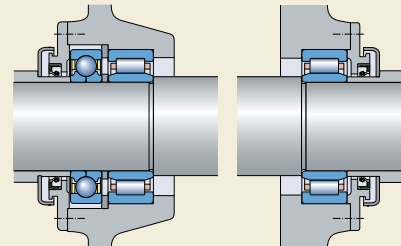

Fig. 5



F

Design considerations

For the bearing systems listed above, angular misalignment of the shaft relative to the housing must be kept to a minimum. If this is not possible, SKF recommends a self-aligning bearing system comprised of either:

- spherical roller bearing / CARB toroidal roller bearing (→ **fig. 6**)
- self-aligning ball bearing / CARB toroidal roller bearing

The ability of this bearing system to accommodate angular misalignment of the shaft relative to the housing, as well as axial displacement of the shaft within the CARB bearing, avoids induced internal axial loads in the bearing system.

For bearing systems with a rotating inner ring load, where changes in the shaft length are to be accommodated between the bearing and its seat, axial displacement should take place between the bearing outer ring and its housing. The most common combinations are:

- deep groove ball bearing / deep groove ball bearing (→ **fig. 7**)
- self-aligning ball or spherical roller bearing / self-aligning ball or spherical roller bearing (→ **fig. 8**)
- matched single row angular contact ball bearings / deep groove ball bearing (→ **fig. 9**)

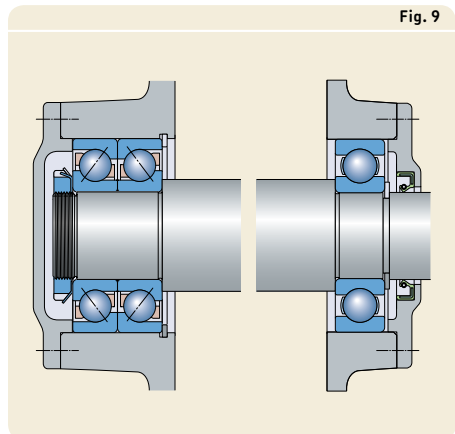
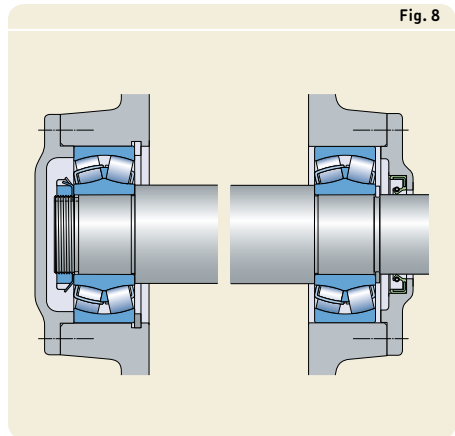
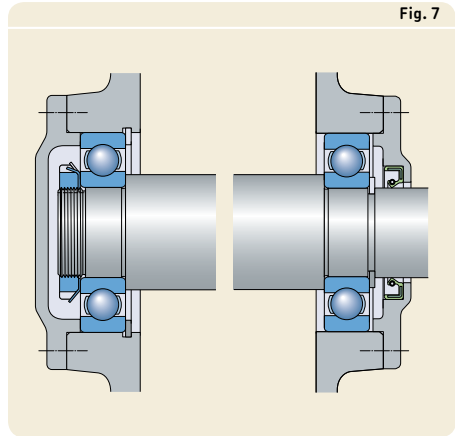
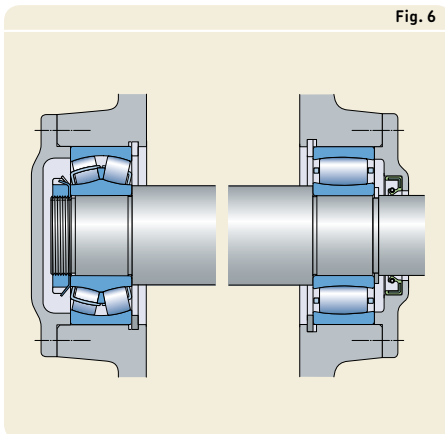

Adjusted bearing system

In an adjusted bearing system, the shaft is located axially in one direction by one bearing arrangement and in the opposite direction by the other. This system is referred to as cross-located and is generally used for short shafts. The most suitable bearings are:

- angular contact ball bearings (→ **fig. 10**)
- tapered roller bearings (→ **fig. 11**)

In a number of cases where single row angular contact ball bearings or tapered roller bearings are used for a cross-locating bearing system preload may be necessary (→ *Bearing preload*, **page 214**).

Fig. 10

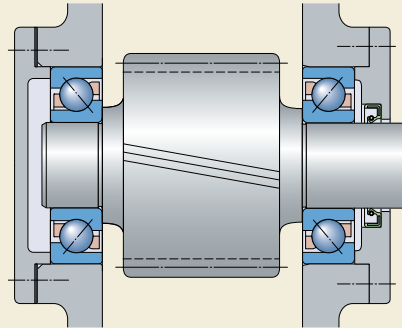
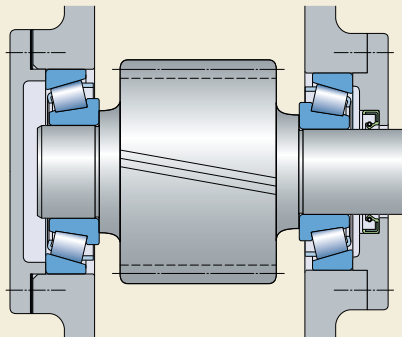

Fig. 11



Design considerations

Floating bearing system

Like an adjusted bearing system, a floating bearing system is also cross-locating. However, a floating bearing system is more suitable for applications where axial stability of the shaft is less demanding or where other components on the shaft locate it axially. Suitable bearings for this system are:

- deep groove ball bearings (→ fig. 12)
- self-aligning ball bearings
- spherical roller bearings

In this system, it is important that one ring of each bearing, preferably the outer ring, is able to move axially on its seat. A floating bearing system can also be obtained with two NJ design cylindrical roller bearings used in mirrored arrangements with offset rings (→ fig. 13). In this case, axial displacement can occur within the bearings.

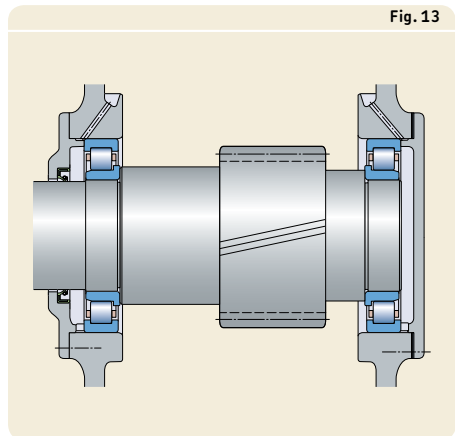
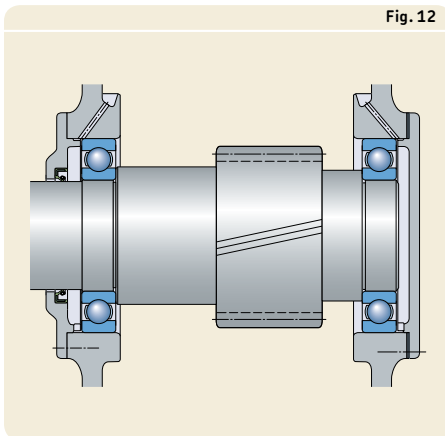

Radial location of bearings

If the load carrying ability of a bearing is to be fully exploited, its rings or washers should be fully supported around their complete circumference and across the entire width of the raceway. The support, which should be firm and even, can be provided by a cylindrical or tapered seat or, for thrust bearing washers, by a flat (plane) support surface. This means that bearing seats should be manufactured to adequate tolerance classes and uninterrupted by grooves, holes or other features. In addition, the bearing rings should be reliably secured to prevent them from turning on or turning in their seats under load.

In general, satisfactory radial location and adequate support can only be obtained when the rings are mounted with an appropriate degree of interference (→ *Bearing clearance*, **page 213** and *Bearing preload*, **page 214**). Inadequately or incorrectly secured bearing rings generally can cause damage to the bearing system. However, when axial displacement (as with a non-locating bearing) or easy mounting and dismantling are required, an interference fit cannot always be used. In cases where a loose fit is required, special precautions are necessary to limit the inevitable wear from creep (turning). This can be done, for example, by surface hardening the bearing seat and abutments, lubricating mating surfaces via special lubrication grooves, or providing locating slots in the bearing ring side faces to accommodate keys or other holding devices (→ **fig 12**, **page 499**).

Selecting fits

When selecting fits, the information provided in this section should be considered, together with the general guidelines in the section thereafter.

1. Conditions of rotation

Conditions of rotation refer to the bearing ring being considered relative to the direction of the load (→ **table 1**, **page 166**). Essentially, there are three different conditions:

- rotating load
- stationary load
- direction of load indeterminate

Rotating loads pertain if either the ring or the direction of the applied load is stationary while the other rotates. Heavy loads that do not rotate but oscillate, such as loads acting on connecting rod bearings, are generally considered to be rotating loads. A bearing ring subjected to a rotating load creeps on its seat if mounted with a too loose fit, and leads to wear and/or fretting corrosion of the contact surfaces. To prevent this, an adequate interference fit between the rotating ring and its seat must be used. The degree of interference is dictated by the operating conditions (→ **points 2** and **4** below).

Stationary loads pertain if either both the bearing ring and the direction of the applied load are stationary or both are rotating at the same speed. Under these conditions, a bearing ring normally does not turn on its seat. Therefore, the ring does not need to have an interference fit, unless it is required for other reasons.

Direction of load indeterminate refers to variable external loads, shock loads, vibrations and unbalanced loads in high-speed applications. These give rise to changes in the direction of load, which cannot be accurately described. When the direction of load is indeterminate and particularly where heavy loads are involved, SKF recommends an interference fit for both rings. For the inner ring, the recommended fit for a rotating load is normally used. However, when the outer ring must be free to move axially in the housing, and the load is not heavy, a somewhat looser fit than that recommended for a rotating load can be used.

Design considerations

2. Magnitude of the load

The degree of interference between the inner ring and the shaft seat must be selected based on the magnitude of the load on the bearing. Typically, the inner ring of a bearing deforms proportionately to the load. This deformation can loosen the interference fit between the inner ring and shaft, causing the ring to creep (turn) on its shaft seat. The heavier the load, the tighter the interference fit required (→ **fig. 14**). An interference fit has an influ-

ence on the bearing clearance or preload (→ *Bearing clearance*, **page 213** and *Bearing preload*, **page 214**). Shock loads and vibration also need to be considered, as a tighter fit might be necessary under these conditions.

Magnitude of bearing load is defined as:

- light load: $P \leq 0,05 C$
- normal load: $0,05 C < P \leq 0,1 C$
- heavy load: $0,1 C < P \leq 0,15 C$
- very heavy load: $P > 0,15 C$

Table 1

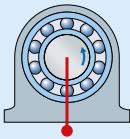
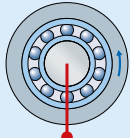
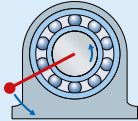
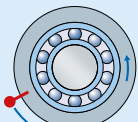
Conditions of rotation and loading				
Operating conditions	Schematic illustration	Load condition	Example	Recommended fits
Rotating inner ring Stationary outer ring Constant load direction		Rotating load on the inner ring Stationary load on the outer ring	Belt driven shafts	Interference fit for the inner ring Loose fit for the outer ring possible
Stationary inner ring Rotating outer ring Constant load direction		Stationary load on the inner ring Rotating load on the outer ring	Conveyor idlers Car wheel hub bearings	Loose fit for the inner ring possible Interference fit for the outer ring
Rotating inner ring Stationary outer ring Load rotates with the inner ring		Stationary load on the inner ring Rotating load on the outer ring	Vibratory applications Vibrating screens or motors	Interference fit for the outer ring Loose fit for the inner ring possible
Stationary inner ring Rotating outer ring Load rotates with the outer ring		Rotating load on the inner ring Stationary load on the outer ring	Gyratory crusher (Merry-go-round drivers)	Interference fit for the inner ring Loose fit for the outer ring possible

3. Bearing internal clearance

Bearings with an interference fit on a shaft or in a housing elastically deform (expand or compress) the ring to reduce the bearing internal clearance. However, a certain minimum clearance should remain (→ *Bearing clearance*, page 213). The interference fit can be so tight that bearings with an initial clearance that is greater than Normal have to be used to prevent unwanted preload (→ fig. 15).

4. Temperature differences

In many applications, the inner ring temperature is higher than the outer ring temperature. This can reduce internal clearance (→ fig. 16 and *Bearing clearance*, page 213) or increase preload (→ *Bearing preload*, page 214).

In operation, bearing rings normally reach a temperature that is higher than that of the components to which they are fitted. This can loosen the fit of the inner ring on its seat, while outer ring expansion can prevent the desired axial displacement of the ring in its housing. Fast start-ups can also loosen the inner ring fit when frictional heat generated by the bearing is not dissipated quickly enough. In some cases, friction from bearing seals can generate enough heat to loosen the inner ring fit.

Temperature differences and the direction of heat flow in the bearing arrangement must be taken into consideration.

5. Running accuracy

For applications requiring a high degree of running accuracy, interference fits are recommended. Loose fits can reduce stiffness and contribute to vibration. Bearing seats should conform at least to IT5 tolerance grade for the shaft and IT6 tolerance grade for the housing. Tight total run-out tolerances should also be applied (→ table 11, page 202).

Fig. 14

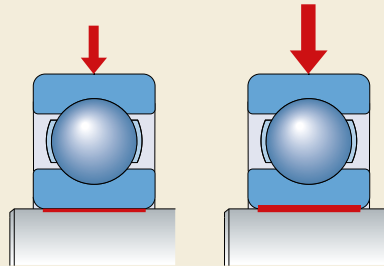

Fig. 15

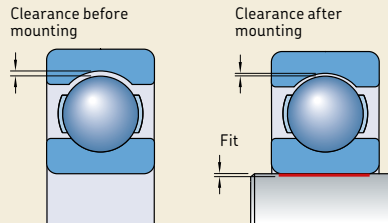
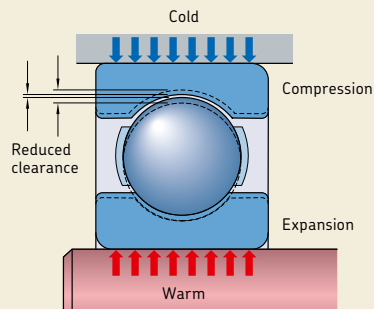

Fig. 16



Design considerations

6. Design and material of the shaft and housing

The fit of a bearing ring on its seat must not distort the ring (out-of-round). This can be caused, for example, by discontinuities in the seat surface. Therefore, SKF generally does not recommend split housings where outer rings require a tight, M7 or even tighter, interference fit.

The selected tolerance class for a split housing should not result in a fit tighter than that obtained with tolerance group H (or at most, tolerance group K).

To provide adequate support for bearing rings mounted in thin-walled housings, light alloy housings or on hollow shafts, tighter interference fits than those normally recommended for thick-walled steel or cast iron housings or for solid shafts should be used (→ *Fits for hollow shafts*, page 176). Also, sometimes interference fits that are not so tight may be required if the shaft material has a higher coefficient of thermal expansion than standard steel.

7. Ease of mounting and dismounting

Bearings with a loose fit are usually easier to mount and dismount than those with interference fits. In applications that require interference fits and relatively easy mounting and dismounting, separable bearings or bearings with a tapered bore should be considered (→ *Bearings with a tapered bore*). Bearings with a tapered bore can be mounted on adapter or withdrawal sleeves on plain or stepped shafts, or mounted directly on a tapered shaft seat (→ figs. 25 to 27, page 207).

8. Displacement of the bearing in the non-locating position

If bearings in the non-locating position cannot accommodate axial displacement internally (within the bearing), the outer ring must be free to move axially on its seat at all times. To do this, the ring that carries a stationary load can have a loose fit (→ fig. 20, page 205). For some particular applications, where the outer ring is under stationary load and the bearing must move axially in the housing seat to accommodate displacement, a hardened intermediate bushing or sleeve can be fitted in the housing bore to prevent the bearing from damaging its seat. Any damage to the housing seat can restrict axial movement or prohibit it

entirely over time. This is particularly important if the housing is made of a light alloy.

If needle roller bearings, CARB toroidal roller bearings or cylindrical roller bearings without flanges on one ring are used, both bearing rings can be mounted with an interference fit, because axial displacement can take place internally, within the bearing.

Bearings with a tapered bore

Bearings with a tapered bore can be mounted directly on tapered shaft seats, or on adapter or withdrawal sleeves (→ **figs. 25 to 28, page 207**). Sleeves that are fitted to cylindrical shaft seats have an external taper. Whether the bearing is mounted on a sleeve or directly on the shaft, the fit of the bearing inner ring is not pre-determined by the bearing seat, as is the case for bearings with a cylindrical bore. Instead, the fit for bearings with a tapered bore is determined by the distance through which the ring is driven up on its tapered seat or on the sleeve. Special precautions relative to the internal clearance reduction must be considered as mentioned under *Bearing clearance* (→ **page 213**) and under *Self-aligning ball bearings* (→ **page 537**), *Spherical roller bearings* (→ **page 879**), and *CARB toroidal roller bearings* (→ **page 957**).

If the bearings are to be mounted on an adapter or withdrawal sleeve, larger diameter tolerances are permitted for the sleeve seat, but the tolerances for total radial run-out must be tighter (→ *Dimensional and geometrical tolerances of bearing seats and abutments, page 200*).

Recommended fits

The tolerances for the bore and outside diameter of rolling bearings are standardized internationally (→ *Tolerances, page 132*).

To achieve an interference or loose fit for metric bearings with a cylindrical bore and outside surface, suitable tolerance classes for the bearing seat on the shaft and in the housing bore are selected from the ISO tolerance system. Only a limited number of ISO tolerance classes need be considered for the shaft and housing seats for rolling bearings. The location of the most commonly used tolerance classes relative to the bearing bore and outside diameter surface are shown in **fig. 17, page 170** (valid for bearings with Normal tolerances).

Each ISO tolerance class is identified by a letter and a number. The letter, lower case for shaft diameters and upper case for housing bores, locates the tolerance zone relative to the nominal dimension. The number indicates the range of the tolerance zone. The higher the number, the larger the tolerance zone.

Recommendations for bearing fits for solid steel shafts are provided in the tables referenced in the following:

- radial bearings with a cylindrical bore (→ **table 2, page 172**)
- thrust bearings (→ **table 3, page 174**)

Recommendations for bearing fits for cast iron and steel housings are provided in the tables referenced in the following:

- radial bearings – non-split housings (→ **table 4, page 174**)
- radial bearings – split or non-split housings (→ **table 5, page 175**)
- thrust bearings (→ **table 6, page 175**)

These recommendations are based on the general selection guidelines described above, which take developments in bearing and housing materials, design and manufacturing into account. Modern bearings and housings can accommodate substantially heavier loads than was previously possible. The recommendations in this catalogue reflect these improvements.

NOTE: All ISO tolerance classes are valid with the envelope requirement (such as H7 $\text{\textcircled{E}}$) in accordance with ISO 14405-1. For practical reasons, this is not indicated in the following tables.

ISO 14405-1 offers more possibilities to specify fits. For additional information, contact the SKF application engineering service.

Design considerations

Stainless steel bearings or shafts

The recommended fits in **tables 2 to 6** (→ **pages 172 to 175**) can be used for stainless steel bearings. However, footnote 3 in **table 2** (→ **page 172**) does not apply, because stainless steel has a much higher coefficient of thermal expansion than standard steel. If tighter fits than those recommended in **table 2** (→ **page 172**) are needed, contact the SKF application engineering service. It may also be necessary to consider the initial bearing clearance, such as when using stainless steel shafts at elevated temperatures (→ *Bearing internal clearance*, **page 149**).

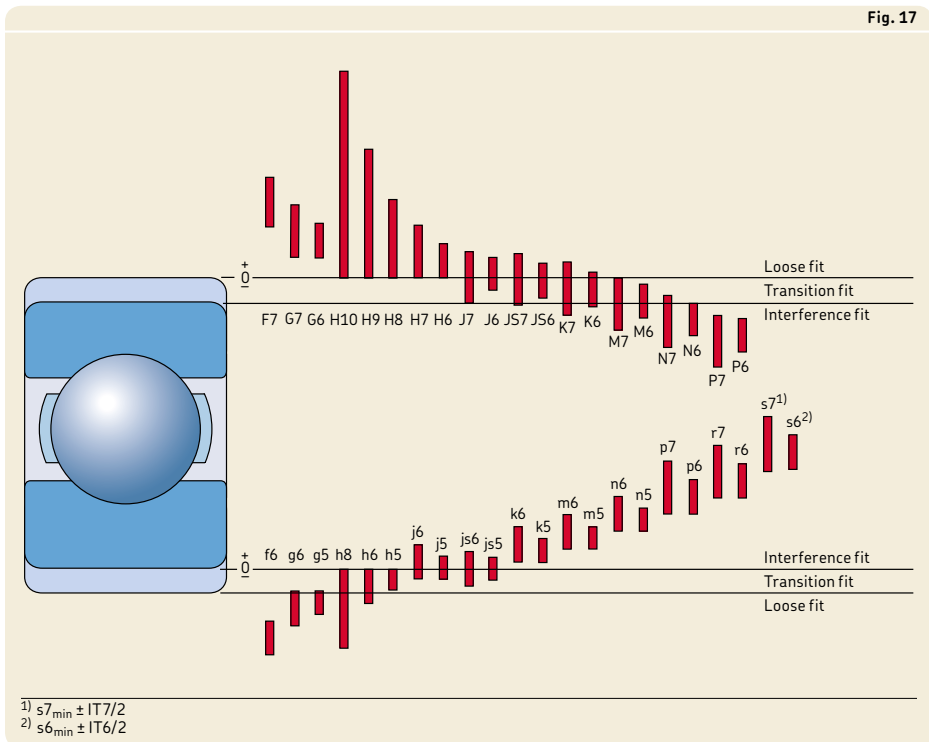

Shaft and housing tolerances and fits

The values listed for the shaft (→ **tables 7, page 178**) and housing (→ **tables 8, page 190**) tolerances enable the character of the fit to be established:

- the upper and lower limits of Normal tolerances for the bearing bore or outside diameter deviations
- the upper and lower limits of the shaft or housing bore diameter deviations in accordance with ISO 286-2
- the smallest and largest values of the theoretical interference (–) or clearance (+) in the fit
- the smallest and largest values of the probable interference (–) or clearance (+) in the fit

The appropriate values for rolling bearing shaft seats are listed for the following tolerances:

- f5, f6, g5, g6, h5 (→ **table 7a, page 178**)
- h6, h8, h9, j5, j6 (→ **table 7b, page 180**)
- js4, js5, js6, js7, k4 (→ **table 7c, page 182**)
- k5, k6, m5, m6, n5 (→ **table 7d, page 184**)
- n6, p6, p7, r6, r7 (→ **table 7e, page 186**)
- $s6_{\min} \pm IT6/2$, $s7_{\min} \pm IT7/2$ (→ **table 7f, page 188**)

The appropriate values for rolling bearing housing seats are listed for the following tolerances:

- F7, G6, G7, H5, H6 (→ **table 8a, page 190**)
- H7, H8, H9, H10, J6 (→ **table 8b, page 192**)
- J7, JS5, JS6, JS7, K5 (→ **table 8c, page 194**)
- K6, K7, M5, M6, M7 (→ **table 8d, page 196**)
- N6, N7, P6, P7 (→ **table 8e, page 198**)

Normal tolerances for the bore and outside diameter, for which the limiting values have been calculated, are valid for all metric rolling bearings except for metric tapered roller bearings when $d \leq 30$ mm or $D \leq 150$ mm and thrust bearings when $D \leq 150$ mm. The diameter tolerances for these bearings deviate from the Normal tolerances for other rolling bearings (→ **tables 3 to 10, pages 137 to 144**).

The values for the probable interference or loose fit cover 99% of all the combinations.

When bearings with higher dimensional accuracy than Normal are used, the bore and outside diameter tolerances are tighter. Therefore, values for an interference or loose fit need to be adjusted correspondingly. For information about calculating these limits more accurately, contact the SKF application engineering service.

NOTE: The signs for clearance and interference in this catalogue are in accordance with ISO 286-1. Clearance is now indicated with a “+” sign and interference with a “–” sign.

Design considerations

Fits for solid steel shafts

Radial bearings with a cylindrical bore¹⁾

Conditions

Examples

Rotating inner ring load or direction of load indeterminate

Light and variable loads ($P \leq 0,05 C$)

Conveyors, lightly loaded gearbox bearings

Normal to heavy loads ($P > 0,05 C$)

General bearing applications, electric motors, turbines, pumps, gearing, wood-working machines

Heavy to very heavy loads and shock loads under difficult operating conditions ($P > 0,1 C$)

Axleboxes for heavy railway vehicles, traction motors, rolling mills, wind turbines

High demands on running accuracy with light loads ($P \leq 0,05 C$)²⁾

Machine tools (precision class bearings)

Stationary inner ring load

Easy axial displacement of inner ring on shaft desirable

Wheels on non-rotating axles

Easy axial displacement of inner ring on shaft unnecessary

Tension pulleys, rope sheaves

Axial loads only

Bearing applications of all kinds

¹⁾ For needle roller bearings → *Shaft and housing tolerances*, page 716. For Y-bearings → *Shaft tolerances*, page 450.

²⁾ All ISO tolerance classes are valid with the envelope requirement (such as H7(E)) in accordance with ISO 14405-1.

³⁾ Ball bearings under normal to heavy loads ($P > 0,05 C$) often require radial internal clearance greater than Normal when the shaft tolerance classes listed above are used. If radial clearance is greater than Normal, but the operating conditions require tighter fits to prevent the inner ring from creeping, use the following tolerance classes:

- k4(E) for shaft diameters 10 to 17 mm
- n6(E) for shaft diameters > 140 to 300 mm
- k5(E) for shaft diameters > 17 to 25 mm
- p6(E) for shaft diameters > 300 to 500 mm
- m5(E) for shaft diameters > 25 to 140 mm

For additional information, contact the SKF application engineering service.

Do not use tighter fits for stainless steel bearings.

⁴⁾ The tolerance in brackets applies to stainless steel bearings.

⁵⁾ For stainless steel bearings within the diameter range 17 to 30 mm, tolerance class j5(E) applies.

Table 2

Shaft diameter [mm] Ball bearings ³⁾	Cylindrical roller bearings	Tapered roller bearings	CARB and spherical roller bearings	Tolerance class ²⁾
≤ 17	–	–	–	js5 (h5) ⁴⁾
> 17 to 100	≤ 25	≤ 25	–	j6 (j5) ⁴⁾
> 100 to 140	> 25 to 60	> 25 to 60	–	k6
–	> 60 to 140	> 60 to 140	–	m6
≤ 10	–	–	–	js5
> 10 to 17	–	–	–	j5 (js5) ⁴⁾
> 17 to 100	–	–	< 25	k5 ⁵⁾
–	≤ 30	≤ 40	–	k6
> 100 to 140	> 30 to 50	–	25 to 40	m5
> 140 to 200	–	> 40 to 65	–	m6
–	> 50 to 65	–	> 40 to 60	n5 ⁶⁾
> 200 to 500	> 65 to 100	> 65 to 200	> 60 to 100	n6 ⁶⁾
–	> 100 to 280	> 200 to 360	> 100 to 200	p6 ⁷⁾
> 500	–	–	–	p7 ⁶⁾
–	> 280 to 500	> 360 to 500	> 200 to 500	r6 ⁶⁾
–	> 500	> 500	> 500	r7 ⁶⁾
–	> 50 to 65	–	> 50 to 70	n5 ⁶⁾
–	> 65 to 85	> 50 to 110	–	n6 ⁶⁾
–	> 85 to 140	> 110 to 200	> 70 to 140	p6 ⁸⁾
–	> 140 to 300	> 200 to 500	> 140 to 280	r6 ⁹⁾
–	> 300 to 500	–	> 280 to 400	s6 _{min} ± IT6/2 ⁸⁾
–	> 500	> 500	> 400	s7 _{min} ± IT7/2 ⁸⁾
8 to 240	–	–	–	js4
–	25 to 40	25 to 40	–	js4 (j5) ¹⁰⁾
–	> 40 to 140	> 40 to 140	–	k4 (k5) ¹⁰⁾
–	> 140 to 200	> 140 to 200	–	m5
–	> 200 to 500	> 200 to 500	–	n5
				g6 ¹²⁾
				h6
≤ 250	–	≤ 250	≤ 250	j6
> 250	–	> 250	> 250	js6

⁶⁾ Bearings with radial internal clearance greater than Normal may be necessary.

⁷⁾ Bearings with radial internal clearance greater than Normal are recommended for $d \leq 150$ mm. When $d > 150$ mm, bearings with radial internal clearance greater than Normal may be necessary.

⁸⁾ Bearings with radial internal clearance greater than Normal are recommended.

⁹⁾ Bearings with radial internal clearance greater than Normal may be necessary. For cylindrical roller bearings, radial internal clearance greater than Normal is recommended.

¹⁰⁾ The tolerance class in brackets applies to tapered roller bearings. For lightly loaded tapered roller bearings adjusted via the inner ring, tolerance class js5 (E) or js6 (E) should be used.

¹¹⁾ For a high degree of running accuracy, bearings with higher precision than Normal are required. The tolerances for the bore and outside diameter are tighter, which has an influence on the probable fits. To obtain relevant values, contact the SKF application engineering service.

¹²⁾ Tolerance class f6 (E) can be selected for large bearings to facilitate axial displacement on the shaft.



Table 3

Fits for solid steel shafts (for thrust bearings) ¹⁾		
Conditions	Shaft diameter [mm]	Tolerance class ²⁾
Axial loads only		
Thrust ball bearings	–	h6
Combined radial and axial loads on spherical roller thrust bearings		
Stationary load on shaft washer	≤ 250	j6
	> 250	js6
Rotating load on shaft washer, or direction of load indeterminate	≤ 200	k6
	> 200 to 400	m6
	> 400	n6

¹⁾ For cylindrical roller thrust bearings → *Cylindrical roller thrust bearings*, page 1037. For needle roller thrust bearings → *Shaft and housing tolerance classes*, page 1068.

²⁾ All ISO tolerance classes are valid with the envelope requirement (such as h7 \oplus) in accordance with ISO 14405-1.

Table 4

Fits for non-split cast iron and steel housings (for radial bearings) ¹⁾			
Conditions	Examples	Tolerance class ²⁾³⁾	Displacement of outer ring
Rotating outer ring load			
Heavy loads on bearings in thin-walled housings, heavy shock loads ($P > 0,1 C$)	Roller bearing wheel hubs, big-end bearings	P7	Cannot be displaced
Normal to heavy loads ($P > 0,05 C$)	Ball bearing wheel hubs, big-end bearings, crane travelling wheels	N7	Cannot be displaced
Light and variable loads ($P \leq 0,05 C$)	Conveyor rollers, rope sheaves, belt tensioner pulleys	M7	Cannot be displaced
Direction of load indeterminate			
Heavy shock loads	Electric traction motors	M7	Cannot be displaced
Normal to heavy loads ($P > 0,05 C$), axial displacement of outer ring unnecessary	Electric motors, pumps, crankshaft bearings	K7	In most cases, cannot be displaced
Accurate or quiet running⁴⁾			
Ball bearings	Small electric motors	J6 ⁵⁾	In most cases, can be displaced
Tapered roller bearings ⁶⁾			

¹⁾ For drawn cup, alignment and combined needle roller bearings → *Shaft and housing tolerances*, page 716.

²⁾ All ISO tolerance classes are valid with the envelope requirement (such as H7 \oplus) in accordance with ISO 14405-1.

³⁾ For ball bearings, when $D \leq 100$ mm, IT6 tolerance grade is often preferable and is recommended for bearings with thin-walled rings, such as in the 7, 8 or 9 diameter series. For these series, total radial run-out tolerances IT4 are also recommended.

⁴⁾ For super-precision bearings to tolerance class P5 or better, other recommendations apply. For additional information, refer to the information available online at skf.com/super-precision.

⁵⁾ Tolerance class H6 \oplus can be selected instead of J6 \oplus to facilitate axial displacement in the housing bore.

⁶⁾ Contact the SKF application engineering service.

Table 5

Fits for split or non-split cast iron and steel housings (for radial bearings)¹⁾

Conditions	Examples	Tolerance class ²⁾³⁾	Displacement of outer ring
Direction of load indeterminate			
Light to normal loads ($P \leq 0,1 C$), axial displacement of outer ring desirable	Medium-size electric motors and generators, pumps, crankshaft bearings	J7	In most cases, can be displaced, but some (induced) axial force might occur
Stationary outer ring load			
Loads of all kinds	General engineering, railway axleboxes	H7 ⁴⁾	Can be displaced
Light to normal loads ($P \leq 0,1 C$) with simple working conditions	General engineering	H8	Can be displaced
Thermal expansion of the shaft	Drying cylinders, large electrical machines with spherical roller bearings	G7 ⁵⁾	Can be displaced

¹⁾ For drawn cup, alignment and combined needle roller bearings → *Shaft and housing tolerances*, page 716.

²⁾ All ISO tolerance classes are valid with the envelope requirement (such as H7(Ⓔ)) in accordance with ISO 14405-1.

³⁾ For ball bearings, when $D \leq 100$ mm, IT6 tolerance grade is often preferable and is recommended for bearings with thin-walled rings, such as in the 7, 8 or 9 diameter series. For these series, cylindricity tolerances IT4 are also recommended.

⁴⁾ For large bearings ($D > 250$ mm) or temperature differences between the outer ring and housing > 10 °C (18 °F), tolerance class G7(Ⓔ) should be used instead of tolerance class H7(Ⓔ).

⁵⁾ For large bearings ($D > 500$ mm) or temperature differences between the outer ring and housing > 10 °C (18 °F), tolerance class F7(Ⓔ) should be used instead of tolerance class G7(Ⓔ).

Table 6

Fits for cast iron and steel housings (for thrust bearings)¹⁾

Conditions	Tolerance class ²⁾	Remarks
Axial loads only		
Thrust ball bearings	H8	For less accurate bearing arrangements, there can be a radial clearance of up to 0,001 D.
Spherical roller thrust bearings where separate bearings provide radial location	–	Housing washer must be fitted with an adequate radial gap so that no radial load can act on the thrust bearings.
Combined radial and axial loads on spherical roller thrust bearings		
Stationary load on housing washer	H7	For additional information, refer to <i>Design of bearing arrangements</i> (→ page 1085).
Rotating load on housing washer	M7	

¹⁾ For cylindrical roller thrust bearings → *Cylindrical roller thrust bearings*, page 1037. For needle roller thrust bearings → For drawn cup, alignment and combined needle roller bearings → *Shaft and housing tolerances*, page 716.

²⁾ All ISO tolerance classes are valid with the envelope requirement (such as H7(Ⓔ)) in accordance with ISO 14405-1.



Fits for hollow shafts

If bearings are to be mounted with an interference fit on a hollow shaft, to achieve the same surface pressure between the inner ring and shaft seat, it is generally necessary to use a tighter interference fit than would be used for a solid shaft. The following diameter ratios are important when deciding on the fit to be used:

$$c_i = \frac{d_i}{d} \quad \text{and} \quad c_e = \frac{d}{d_e}$$

Diameter ratios, c_i , that are $< 0,5$ do not have an appreciable effect on the fit.

If the average outside diameter of the inner ring, i.e. the average diameter between the shoulder and raceway (\rightarrow **diagram 1**), is not known, the diameter ratio c_e can be estimated with sufficient accuracy using

$$c_e = \frac{d}{k(D - d) + d}$$

where

c_i = diameter ratio of the hollow shaft

c_e = diameter ratio of the inner ring

d = outside diameter of the hollow shaft,
bearing bore diameter [mm]

D = bearing outside diameter [mm]

d_i = inside diameter of the hollow shaft [mm]

d_e = average outside diameter of the inner ring [mm] (\rightarrow **diagram 1**)

k = a factor for the bearing type

– for self-aligning ball bearings in the 22 and 23 series, $k = 0,25$

– for cylindrical roller bearings, $k = 0,25$

– for all other bearings, $k = 0,3$

The requisite interference fit for a bearing mounted on a hollow shaft can be determined based on the mean probable interference for the same bearing on a solid shaft, neglecting plastic deformation (smoothing) of the mating surfaces produced during mounting. The mean probable interference for the bearing on a solid shaft, Δ_S , is the mean value of the smallest and largest values of the probable interference listed in **table 7** (\rightarrow **page 178**).

Diagram 1 provides values for the ratio between the mean probable interference of the bearing inner ring on a hollow shaft, Δ_H , and

on a solid shaft, Δ_S , depending on the diameter ratios c_i and c_e .

Example

A 6208 deep groove ball bearing with $d = 40$ mm and $D = 80$ mm is to be mounted on a hollow shaft with a diameter ratio $c_i = 0,8$. What is the requisite interference and what are the appropriate shaft limits?

If the bearing is to be mounted on a solid steel shaft and subjected to normal loads, a tolerance class k5 (E) is recommended. From **table 7d** (\rightarrow **page 184**), for a 40 mm shaft diameter, the mean probable interference $\Delta_S = (22 + 5) / 2 = 13,5$ μm . For $c_i = 0,8$ and

$$c_e = \frac{40}{0,3(80 - 40) + 40} = 0,77$$

so that from **diagram 1** the ratio $\Delta_H / \Delta_S = 1,7$. Therefore, the requisite interference for the hollow shaft $\Delta_H = 1,7 \times 13,5 = 23$ μm . Consequently, tolerance class m6 (E) is selected for the hollow shaft as this gives a similar fit as k5 (E) for a solid shaft.

Diagram 1

Relationship of interference Δ_H , needed for a hollow steel shaft, to the known interference Δ_S for a solid steel shaft

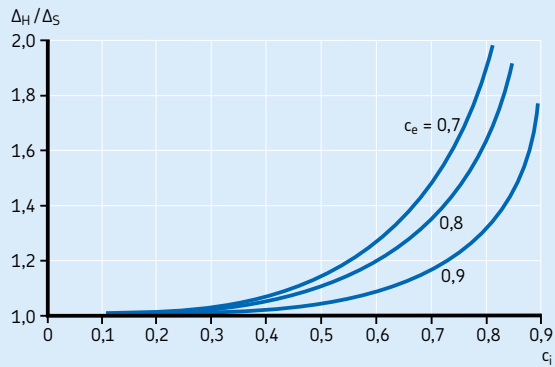
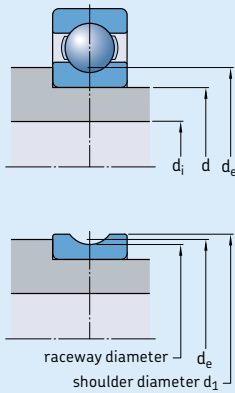



Table 7a

Shaft tolerances and resultant fits



Shaft		Bearing		Shaft diameter deviations, resultant fits																													
Nominal diameter d		Bore diameter tolerance Δ _{dmp}		Tolerance classes																													
				f5(Ⓔ)		f6(Ⓔ)		g5(Ⓔ)		g6(Ⓔ)		h5(Ⓔ)																					
				Deviations (shaft diameter)																													
				Theoretical interference (-)/clearance (+)																													
				Probable interference (-)/clearance (+)																													
over	incl.	low	high	μm																													
mm		μm		μm																													
-	3	-8	0	-6	-10	-6	-12	-2	-6	-2	-8	0	-4	-2	+10	-2	+12	-6	+6	-6	+8	-8	+4	-1	+9	0	+10	-5	+5	-4	+6	-7	+3
3	6	-8	0	-10	-15	-10	-18	-4	-9	-4	-12	0	-5	+2	+15	+2	+18	-4	+9	-4	+12	-8	+5	+3	+14	+4	+16	-3	+8	-2	+10	-7	+4
6	10	-8	0	-13	-19	-13	-22	-5	-11	-5	-14	0	-6	+5	+19	+5	+22	-3	+11	-3	+14	-8	+6	+7	+17	+7	+20	-1	+9	-1	+12	-6	+4
10	18	-8	0	-16	-24	-16	-27	-6	-14	-6	-17	0	-8	+8	+24	+8	+27	-2	+14	-2	+17	-8	+8	+10	+22	+10	+25	0	+12	0	+15	-6	+6
18	30	-10	0	-20	-29	-20	-33	-7	-16	-7	-20	0	-9	+10	+29	+10	+33	-3	+16	-3	+20	-10	+9	+12	+27	+13	+30	-1	+14	0	+17	-8	+7
30	50	-12	0	-25	-36	-25	-41	-9	-20	-9	-25	0	-11	+13	+36	+13	+41	-3	+20	-3	+25	-12	+11	+16	+33	+17	+37	0	+17	+1	+21	-9	+8
50	80	-15	0	-30	-43	-30	-49	-10	-23	-10	-29	0	-13	+15	+43	+15	+49	-5	+23	-5	+29	-15	+13	+19	+39	+19	+45	-1	+19	-1	+25	-11	+9
80	120	-20	0	-36	-51	-36	-58	-12	-27	-12	-34	0	-15	+16	+51	+16	+58	-8	+27	-8	+34	-20	+15	+21	+46	+22	+52	-3	+22	-2	+28	-15	+10
120	180	-25	0	-43	-61	-43	-68	-14	-32	-14	-39	0	-18	+18	+61	+18	+68	-11	+32	-11	+39	-25	+18	+24	+55	+25	+61	-5	+26	-4	+32	-19	+12
180	250	-30	0	-50	-70	-50	-79	-15	-35	-15	-44	0	-20	+20	+70	+20	+79	-15	+35	-15	+44	-30	+20	+26	+64	+28	+71	-9	+29	-7	+36	-24	+14
250	315	-35	0	-56	-79	-56	-88	-17	-40	-17	-49	0	-23	+21	+79	+21	+88	-18	+40	-18	+49	-35	+23	+29	+71	+30	+79	-10	+32	-9	+40	-27	+15
315	400	-40	0	-62	-87	-62	-98	-18	-43	-18	-54	0	-25	+22	+87	+22	+98	-22	+43	-22	+54	-40	+25	+30	+79	+33	+87	-14	+35	-11	+43	-32	+17
400	500	-45	0	-68	-95	-68	-108	-20	-47	-20	-60	0	-27	+23	+95	+23	+108	-25	+47	-25	+60	-45	+27	+32	+86	+35	+96	-16	+38	-13	+48	-36	+18

Values are valid for most bearings with Normal tolerances. For exceptions, refer to *Shaft and housing tolerances and fits* (→ page 171).

Table 7a

Shaft tolerances and resultant fits



Shaft		Bearing		Shaft diameter deviations, resultant fits									
Nominal diameter d		Bore diameter tolerance Δ _{dmp}		Tolerance classes									
				f5		f6		g5		g6		h5	
over	incl.	low	high	Deviations (shaft diameter)									
				Theoretical interference (-)/clearance (+)									
				Probable interference (-)/clearance (+)									
mm		μm		μm									
500	630	-50	0	-76	-104	-76	-120	-22	-50	-22	-66	0	-28
				+26	+104	+26	+120	-28	+50	-28	+66	-50	+28
				+36	+94	+39	+107	-18	+40	-15	+53	-40	+18
630	800	-75	0	-80	-112	-80	-130	-24	-56	-24	-74	0	-32
				+5	+112	+5	+130	-51	+56	-51	+74	-75	+32
				+17	+100	+22	+113	-39	+44	-34	+57	-63	+20
800	1 000	-100	0	-86	-122	-86	-142	-26	-62	-26	-82	0	-36
				-14	+122	-14	+142	-74	+62	-74	+82	-100	+36
				0	+108	+6	+122	-60	+48	-54	+62	-86	+22
1 000	1 250	-125	0	-98	-140	-98	-164	-28	-70	-28	-94	0	-42
				-27	+140	-27	+164	-97	+70	-97	+94	-125	+42
				-10	+123	-3	+140	-80	+53	-73	+70	-108	+25
1 250	1 600	-160	0	-110	-160	-110	-188	-30	-80	-30	-108	0	-50
				-50	+160	-50	+188	-130	+80	-130	+108	-160	+50
				-29	+139	-20	+158	-109	+59	-100	+78	-139	+29
1 600	2 000	-200	0	-120	-180	-120	-212	-32	-92	-32	-124	0	-60
				-80	+180	-80	+212	-168	+92	-168	+124	-200	+60
				-55	+155	-45	+177	-143	+67	-133	+89	-175	+35

Values are valid for most bearings with Normal tolerances. For exceptions, refer to *Shaft and housing tolerances and fits* (→ page 171).



Table 7b

Shaft tolerances and resultant fits

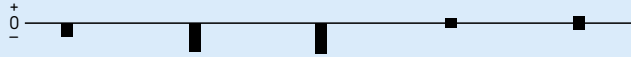

Shaft Nominal diameter d		Bearing Bore diameter tolerance Δ_{dmp}		Shaft diameter deviations, resultant fits									
				Tolerance classes									
				h6(E)	h8(E)	h9(E)	j5(E)	j6(E)					
				Deviations (shaft diameter)									
				Theoretical interference (-)/clearance (+)									
				Probable interference (-)/clearance (+)									
over	incl.	low	high	µm									
mm		µm		µm									
-	3	-8	0	0	-6	0	-14	0	-25	+2	-2	+4	-2
				-8	+6	-8	+14	-8	+25	-10	+2	-12	+2
				-6	+4	-6	+12	-5	+22	-9	+1	-10	0
3	6	-8	0	0	-8	0	-18	0	-30	+3	-2	+6	-2
				-8	+8	-8	+18	-8	+30	-11	+2	-14	+2
				-6	+6	-5	+15	-5	+27	-10	+1	-12	0
6	10	-8	0	0	-9	0	-22	0	-36	+4	-2	+7	-2
				-8	+9	-8	+22	-8	+36	-12	+2	-15	+2
				-6	+7	-5	+19	-5	+33	-10	0	-13	0
10	18	-8	0	0	-11	0	-27	0	-43	+5	-3	+8	-3
				-8	+11	-8	+27	-8	+43	-13	+3	-16	+3
				-6	+9	-5	+24	-5	+40	-11	+1	-14	+1
18	30	-10	0	0	-13	0	-33	0	-52	+5	-4	+9	-4
				-10	+13	-10	+33	-10	+52	-15	+4	-19	+4
				-7	+10	-6	+29	-6	+48	-13	+2	-16	+1
30	50	-12	0	0	-16	0	-39	0	-62	+6	-5	+11	-5
				-12	+16	-12	+39	-12	+62	-18	+5	-23	+5
				-8	+12	-7	+34	-7	+57	-15	+2	-19	+1
50	80	-15	0	0	-19	0	-46	0	-74	+6	-7	+12	-7
				-15	+19	-15	+46	-15	+74	-21	+7	-27	+7
				-11	+15	-9	+40	-9	+68	-17	+3	-23	+3
80	120	-20	0	0	-22	0	-54	0	-87	+6	-9	+13	-9
				-20	+22	-20	+54	-20	+87	-26	+9	-33	+9
				-14	+16	-12	+46	-12	+79	-21	+4	-27	+3
120	180	-25	0	0	-25	0	-63	0	-100	+7	-11	+14	-11
				-25	+25	-25	+63	-25	+100	-32	+11	-39	+11
				-18	+18	-15	+53	-15	+90	-26	+5	-32	+4
180	250	-30	0	0	-29	0	-72	0	-115	+7	-13	+16	-13
				-30	+29	-30	+72	-30	+115	-37	+13	-46	+13
				-22	+21	-18	+60	-17	+102	-31	+7	-38	+5
250	315	-35	0	0	-32	0	-81	0	-130	+7	-16	+16	-16
				-35	+32	-35	+81	-35	+130	-42	+16	-51	+16
				-26	+23	-22	+68	-20	+115	-34	+8	-42	+7
315	400	-40	0	0	-36	0	-89	0	-140	+7	-18	+18	-18
				-40	+36	-40	+89	-40	+140	-47	+18	-58	+18
				-29	+25	-25	+74	-23	+123	-39	+10	-47	+7
400	500	-45	0	0	-40	0	-97	0	-155	+7	-20	+20	-20
				-45	+40	-45	+97	-45	+155	-52	+20	-65	+20
				-33	+28	-28	+80	-26	+136	-43	+11	-53	+8

Values are valid for most bearings with Normal tolerances. For exceptions, refer to *Shaft and housing tolerances and fits* (→ page 171).

Table 7b

Shaft tolerances and resultant fits

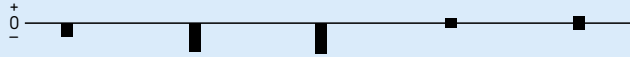

Shaft		Bearing		Shaft diameter deviations, resultant fits									
Nominal diameter d		Bore diameter tolerance Δ _{dmp}		Tolerance classes									
				h6	h8		h9		j5		j6		
				Deviations (shaft diameter)									
				Theoretical interference (-)/clearance (+)									
				Probable interference (-)/clearance (+)									
over	incl.	low	high	μm									
mm		μm		μm									
500	630	-50	0	0	-44	0	-110	0	-175	-	-	+22	-22
				-50	+44	-50	+110	-50	+175	-	-	-72	+22
				-37	+31	-31	+91	-29	+154	-	-	-59	+9
630	800	-75	0	0	-50	0	-125	0	-200	-	-	+25	-25
				-75	+50	-75	+125	-75	+200	-	-	-100	+25
				-58	+33	-48	+98	-45	+170	-	-	-83	+8
800	1 000	-100	0	0	-56	0	-140	0	-230	-	-	+28	-28
				-100	+56	-100	+140	-100	+230	-	-	-128	+28
				-80	+36	-67	+107	-61	+191	-	-	-108	+8
1 000	1 250	-125	0	0	-66	0	-165	0	-260	-	-	+33	-33
				-125	+66	-125	+165	-125	+260	-	-	-158	+33
				-101	+42	-84	+124	-77	+212	-	-	-134	+9
1 250	1 600	-160	0	0	-78	0	-195	0	-310	-	-	+39	-39
				-160	+78	-160	+195	-160	+310	-	-	-199	+39
				-130	+48	-109	+144	-100	+250	-	-	-169	+9
1 600	2 000	-200	0	0	-92	0	-230	0	-370	-	-	+46	-46
				-200	+92	-200	+230	-200	+370	-	-	-246	+46
				-165	+57	-138	+168	-126	+296	-	-	-211	+11

Values are valid for most bearings with Normal tolerances. For exceptions, refer to *Shaft and housing tolerances and fits* (→ page 171).



Table 7c

Shaft tolerances and resultant fits

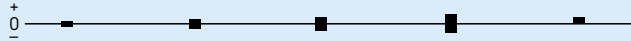

Shaft		Bearing		Shaft diameter deviations, resultant fits																													
Nominal diameter d		Bore diameter tolerance Δ _{dmp}		Tolerance classes																													
				js4(Ⓔ)	js5(Ⓔ)	js6(Ⓔ)	js7(Ⓔ)	k4(Ⓔ)																									
				Deviations (shaft diameter)																													
				Theoretical interference (-)/clearance (+)																													
				Probable interference (-)/clearance (+)																													
over	incl.	low	high	μm																													
mm		μm		μm																													
-	3	-8	0	+1,5	-1,5	+2	-2	+3	-3	+5	-5	+3	0	-9,5	+1,5	-10	+2	-11	+3	-13	+5	-11	0	-8,5	+0,5	-9	+1	-9	+1	-11	+3	-10	-1
3	6	-8	0	+2	-2	+2,5	-2,5	+4	-4	+6	-6	+5	+1	-10	+2	-10,5	+2,5	-12	+4	-14	+6	-13	-1	-9	+1	-9	+1	-10	+2	-12	+4	-12	-2
6	10	-8	0	+2	-2	+3	-3	+4,5	-4,5	+7,5	-7,5	+5	+1	-10	+2	-11	+3	-12,5	+4,5	-15,5	+7,5	-13	-1	-9	+1	-9	+1	-11	+3	-13	+5	-12	-2
10	18	-8	0	+2,5	-2,5	+4	-4	+5,5	-5,5	+9	-9	+6	+1	-10,5	+2,5	-12	+4	-13,5	+5,5	-17	+9	-14	-1	-9,5	+1,5	-10	+2	-11	+3	-14	+6	-13	-2
18	30	-10	0	+3	-3	+4,5	-4,5	+6,5	-6,5	+10,5	-10,5	+8	+2	-13	+3	-14,5	+4,5	-16,5	+6,5	-20,5	+10,5	-18	-2	-10,5	+1,5	-12	+2	-14	+4	-17	+7	-16	-4
30	50	-12	0	+3,5	-3,5	+5,5	-5,5	+8	-8	+12,5	-12,5	+9	+2	-15,5	+3,5	-17,5	+5,5	-20	+8	-24,5	+12,5	-21	-2	-13,5	+1,5	-15	+3	-16	+4	-20	+8	-19	-4
50	80	-15	0	+4	-4	+6,5	-6,5	+9,5	-9,5	+15	-15	+10	+2	-19	+4	-21,5	+6,5	-24,5	+9,5	-30	+15	-25	-2	-15,5	+1,5	-18	+3	-20	+5	-25	+10	-22	-5
80	120	-20	0	+5	-5	+7,5	-7,5	+11	-11	+17,5	-17,5	+13	+3	-25	+5	-27,5	+7,5	-31	+11	-37,5	+17,5	-33	-3	-22	+2	-23	+3	-25	+5	-31	+11	-30	-6
120	180	-25	0	+6	-6	+9	-9	+12,5	-12,5	+20	-20	+15	+3	-31	+6	-34	+9	-37,5	+12,5	-45	+20	-40	-3	-27	+2	-28	+3	-31	+6	-37	+12	-36	-7
180	250	-30	0	+7	-7	+10	-10	+14,5	-14,5	+23	-23	+18	+4	-37	+7	-40	+10	-44,5	+14,5	-53	+23	-48	-4	-32	+2	-34	+4	-36	+6	-43	+13	-43	-9
250	315	-35	0	+8	-8	+11,5	-11,5	+16	-16	+26	-26	+20	+4	-44	+8	-46,5	+11,5	-51	+16	-61	+26	-55	-4	-37	+2	-39	+4	-42	+7	-49	+14	-49	-10
315	400	-40	0	+9	-9	+12,5	-12,5	+18	-18	+28,5	-28,5	+22	+4	-49	+9	-52,5	+12,5	-58	+18	-68,5	+28,5	-62	-4	-42	+2	-44	+4	-47	+7	-55	+15	-55	-11
400	500	-45	0	+10	-10	+13,5	-13,5	+20	-20	+31,5	-31,5	+25	+5	-55	+10	-58,5	+13,5	-65	+20	-76,5	+31,5	-70	-5	-48	+3	-49	+4	-53	+8	-62	+17	-63	-12

Values are valid for most bearings with Normal tolerances. For exceptions, refer to *Shaft and housing tolerances and fits* (→ page 171).

Table 7c

Shaft tolerances and resultant fits

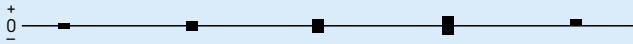

Shaft		Bearing		Shaft diameter deviations, resultant fits									
Nominal diameter d		Bore diameter tolerance Δ_{dmp}		Tolerance classes									
				js4 [Ⓔ]	js5 [Ⓔ]	js6 [Ⓔ]	js7 [Ⓔ]	k4 [Ⓔ]					
				Deviations (shaft diameter)									
over	incl.	low	high	Theoretical interference (-)/clearance (+)									
				Probable interference (-)/clearance (+)									
mm		μm		μm									
500	630	-50	0	-	-	+14	-14	+22	-22	+35	-35	-	-
				-	-	-64	+14	-72	+22	-85	+35	-	-
				-	-	-54	+4	-59	+9	-69	+19	-	-
630	800	-75	0	-	-	+16	-16	+25	-25	+40	-40	-	-
				-	-	-91	+16	-100	+25	-115	+40	-	-
				-	-	-79	+4	-83	+8	-93	+18	-	-
800	1 000	-100	0	-	-	+18	-18	+28	-28	+45	-45	-	-
				-	-	-118	+18	-128	+28	-145	+45	-	-
				-	-	-104	+4	-108	+8	-118	+18	-	-
1 000	1 250	-125	0	-	-	+21	-21	+33	-33	+52	-52	-	-
				-	-	-146	+21	-158	+33	-177	+52	-	-
				-	-	-129	+4	-134	+9	-145	+20	-	-
1 250	1 600	-160	0	-	-	+25	-25	+39	-39	+62	-62	-	-
				-	-	-185	+25	-199	+39	-222	+62	-	-
				-	-	-164	+4	-169	+9	-182	+22	-	-
1 600	2 000	-200	0	-	-	+30	-30	+46	-46	+75	-75	-	-
				-	-	-230	+30	-246	+46	-275	+75	-	-
				-	-	-205	+5	-211	+11	-225	+25	-	-

Values are valid for most bearings with Normal tolerances. For exceptions, refer to *Shaft and housing tolerances and fits* (→ page 171).

F

Table 7d

Shaft tolerances and resultant fits



Shaft		Bearing		Shaft diameter deviations, resultant fits																													
Nominal diameter d		Bore diameter tolerance Δ _{dmp}		Tolerance classes																													
				k5		k6		m5		m6		n5																					
over	incl.	low	high	Deviations (shaft diameter)																													
				Theoretical interference (-)																													
				Probable interference (-)																													
mm		μm		μm																													
-	3	-8	0	+4	0	+6	0	+6	+2	+8	+2	+8	+4	-12	0	-14	0	-14	-2	-16	-2	-16	-4	-11	-1	-12	-2	-13	-3	-14	-4	-15	-5
3	6	-8	0	+6	+1	+9	+1	+9	+4	+12	+4	+13	+8	-14	-1	-17	-1	-17	-4	-20	-4	-21	-8	-13	-2	-15	-3	-16	-5	-18	-6	-20	-9
6	10	-8	0	+7	+1	+10	+1	+12	+6	+15	+6	+16	+10	-15	-1	-18	-1	-20	-6	-23	-6	-24	-10	-13	-3	-16	-3	-18	-8	-21	-8	-22	-12
10	18	-8	0	+9	+1	+12	+1	+15	+7	+18	+7	+20	+12	-17	-1	-20	-1	-23	-7	-26	-7	-28	-12	-15	-3	-18	-3	-21	-9	-24	-9	-26	-14
18	30	-10	0	+11	+2	+15	+2	+17	+8	+21	+8	+24	+15	-21	-2	-25	-2	-27	-8	-31	-8	-34	-15	-19	-4	-22	-5	-25	-10	-28	-11	-32	-17
30	50	-12	0	+13	+2	+18	+2	+20	+9	+25	+9	+28	+17	-25	-2	-30	-2	-32	-9	-37	-9	-40	-17	-22	-5	-26	-6	-29	-12	-33	-13	-37	-20
50	80	-15	0	+15	+2	+21	+2	+24	+11	+30	+11	+33	+20	-30	-2	-36	-2	-39	-11	-45	-11	-48	-20	-26	-6	-32	-6	-35	-15	-41	-15	-44	-24
80	120	-20	0	+18	+3	+25	+3	+28	+13	+35	+13	+38	+23	-38	-3	-45	-3	-48	-13	-55	-13	-58	-23	-33	-8	-39	-9	-43	-18	-49	-19	-53	-28
120	180	-25	0	+21	+3	+28	+3	+33	+15	+40	+15	+45	+27	-46	-3	-53	-3	-58	-15	-65	-15	-70	-27	-40	-9	-46	-10	-52	-21	-58	-22	-64	-33
180	250	-30	0	+24	+4	+33	+4	+37	+17	+46	+17	+51	+31	-54	-4	-63	-4	-67	-17	-76	-17	-81	-31	-48	-10	-55	-12	-61	-23	-68	-25	-75	-37
250	315	-35	0	+27	+4	+36	+4	+43	+20	+52	+20	+57	+34	-62	-4	-71	-4	-78	-20	-87	-20	-92	-34	-54	-12	-62	-13	-70	-28	-78	-29	-84	-42
315	400	-40	0	+29	+4	+40	+4	+46	+21	+57	+21	+62	+37	-69	-4	-80	-4	-86	-21	-97	-21	-102	-37	-61	-12	-69	-15	-78	-29	-86	-32	-94	-45
400	500	-45	0	+32	+5	+45	+5	+50	+23	+63	+23	+67	+40	-77	-5	-90	-5	-95	-23	-108	-23	-112	-40	-68	-14	-78	-17	-86	-32	-96	-35	-103	-49

Values are valid for most bearings with Normal tolerances. For exceptions, refer to *Shaft and housing tolerances and fits* (→ page 171).

Table 7d

Shaft tolerances and resultant fits



Shaft Nominal diameter d		Bearing Bore diameter tolerance Δ_{dmp}		Shaft diameter deviations, resultant fits									
				Tolerance classes									
				k5		k6		m5		m6		n5	
				Deviations (shaft diameter)									
				Theoretical interference (-)									
				Probable interference (-)									
over	incl.	low	high	μm									
mm		μm		μm									
500	630	-50	0	+29	0	+44	0	+55	+26	+70	+26	+73	+44
				-78	0	-94	0	-105	-26	-120	-26	-122	-44
				-68	-10	-81	-13	-94	-36	-107	-39	-112	-54
630	800	-75	0	+32	0	+50	0	+62	+30	+80	+30	+82	+50
				-107	0	-125	0	-137	-30	-155	-30	-157	-50
				-95	-12	-108	-17	-125	-42	-138	-47	-145	-62
800	1 000	-100	0	+36	0	+56	0	+70	+34	+90	+34	+92	+56
				-136	0	-156	0	-170	-34	-190	-34	-192	-56
				-122	-14	-136	-20	-156	-48	-170	-54	-178	-70
1 000	1 250	-125	0	+42	0	+66	0	+82	+40	+106	+40	+108	+66
				-167	0	-191	0	-207	-40	-231	-40	-233	-66
				-150	-17	-167	-24	-190	-57	-207	-64	-216	-83
1 250	1 600	-160	0	+50	0	+78	0	+98	+48	+126	+48	+128	+78
				-210	0	-238	0	-258	-48	-286	-48	-288	-78
				-189	-21	-208	-30	-237	-69	-256	-78	-267	-99
1 600	2 000	-200	0	+60	0	+92	0	+118	+58	+150	+58	+152	+92
				-260	0	-292	0	-318	-58	-350	-58	-352	-92
				-235	-25	-257	-35	-293	-83	-315	-93	-327	-117

Values are valid for most bearings with Normal tolerances. For exceptions, refer to *Shaft and housing tolerances and fits* (→ page 171).



Table 7e

Shaft tolerances and resultant fits

Shaft		Bearing		Shaft diameter deviations, resultant fits									
Nominal diameter d		Bore diameter tolerance Δ _{dmp}		Tolerance classes									
				n6(E)	p6(E)	p7(E)	r6(E)	r7(E)					
				Deviations (shaft diameter)									
				Theoretical interference (-)									
				Probable interference (-)									
over	incl.	low	high	μm									
mm		μm											
50	80	-15	0	+39	+20	+51	+32	+62	+32	-	-	-	-
				-54	-20	-66	-32	-77	-32	-	-	-	-
				-50	-24	-62	-36	-72	-38	-	-	-	-
80	100	-20	0	+45	+23	+59	+37	+72	+37	+73	+51	+86	+51
				-65	-23	-79	-37	-92	-37	-93	-51	-106	-51
				-59	-29	-73	-43	-85	-44	-87	-57	-99	-58
100	120	-20	0	+45	+23	+59	+37	+72	+37	+76	+54	+89	+54
				-65	-23	-79	-37	-92	-37	-96	-54	-109	-54
				-59	-29	-73	-43	-85	-44	-90	-60	-102	-61
120	140	-25	0	+52	+27	+68	+43	+83	+43	+88	+63	+103	+63
				-77	-27	-93	-43	-108	-43	-113	-63	-128	-63
				-70	-34	-86	-50	-100	-51	-106	-70	-120	-71
140	160	-25	0	+52	+27	+68	+43	+83	+43	+90	+65	+105	+65
				-77	-27	-93	-43	-108	-43	-115	-65	-130	-65
				-70	-34	-86	-50	-100	-51	-108	-72	-122	-73
160	180	-25	0	+52	+27	+68	+43	+83	+43	+93	+68	+108	+68
				-77	-27	-93	-43	-108	-43	-118	-68	-133	-68
				-70	-34	-86	-50	-100	-51	-111	-75	-125	-76
180	200	-30	0	+60	+31	+79	+50	+96	+50	+106	+77	+123	+77
				-90	-31	-109	-50	-126	-50	-136	-77	-153	-77
				-82	-39	-101	-58	-116	-60	-128	-85	-143	-87
200	225	-30	0	+60	+31	+79	+50	+96	+50	+109	+80	+126	+80
				-90	-31	-109	-50	-126	-50	-139	-80	-156	-80
				-82	-39	-101	-58	-116	-60	-131	-88	-146	-90
225	250	-30	0	+60	+31	+79	+50	+96	+50	+113	+84	+130	+84
				-90	-31	-109	-50	-126	-50	-143	-84	-160	-84
				-82	-39	-101	-58	-116	-60	-135	-92	-150	-94
250	280	-35	0	+66	+34	+88	+56	+108	+56	+126	+94	+146	+94
				-101	-34	-123	-56	-143	-56	-161	-94	-181	-94
				-92	-43	-114	-65	-131	-68	-152	-103	-169	-106
280	315	-35	0	+66	+34	+88	+56	+108	+56	+130	+98	+150	+98
				-101	-34	-123	-56	-143	-56	-165	-98	-185	-98
				-92	-43	-114	-65	-131	-68	-156	-107	-173	-110
315	355	-40	0	+73	+37	+98	+62	+119	+62	+144	+108	+165	+108
				-113	-37	-138	-62	-159	-62	-184	-108	-205	-108
				-102	-48	-127	-73	-146	-75	-173	-119	-192	-121
355	400	-40	0	+73	+37	+98	+62	+119	+62	+150	+114	+171	+114
				-113	-37	-138	-62	-159	-62	-190	-114	-211	-114
				-102	-48	-127	-73	-146	-75	-179	-125	-198	-127
400	450	-45	0	+80	+40	+108	+68	+131	+68	+166	+126	+189	+126
				-125	-40	-153	-68	-176	-68	-211	-126	-234	-126
				-113	-52	-141	-80	-161	-83	-199	-138	-219	-141

Values are valid for most bearings with Normal tolerances. For exceptions, refer to *Shaft and housing tolerances and fits* (→ page 171).

Table 7e

Shaft tolerances and resultant fits

Shaft		Bearing		Shaft diameter deviations, resultant fits									
Nominal diameter d		Bore diameter tolerance Δ _{dmp}		Tolerance classes									
				n6(E)		p6(E)		p7(E)		r6(E)		r7(E)	
				Deviations (shaft diameter)									
				Theoretical interference (-)									
				Probable interference (-)									
over	incl.	low	high	μm									
mm		μm		μm									
450	500	-45	0	+80	+40	+108	+68	+131	+68	+172	+132	+195	+132
				-125	-40	-153	-68	-176	-68	-217	-132	-240	-132
				-113	-52	-141	-80	-161	-83	-205	-144	-225	-147
500	560	-50	0	+88	+44	+122	+78	+148	+78	+194	+150	+220	+150
				-138	-44	-172	-78	-198	-78	-244	-150	-270	-150
				-125	-57	-159	-91	-182	-94	-231	-163	-254	-166
560	630	-50	0	+88	+44	+122	+78	+148	+78	+199	+155	+225	+155
				-138	-44	-172	-78	-198	-78	-249	-155	-275	-155
				-125	-57	-159	-91	-182	-94	-236	-168	-259	-171
630	710	-75	0	+100	+50	+138	+88	+168	+88	+225	+175	+255	+175
				-175	-50	-213	-88	-243	-88	-300	-175	-330	-175
				-158	-67	-196	-105	-221	-110	-283	-192	-308	-197
710	800	-75	0	+100	+50	+138	+88	+168	+88	+235	+185	+265	+185
				-175	-50	-213	-88	-243	-88	-310	-185	-340	-185
				-158	-67	-196	-105	-221	-110	-293	-202	-318	-207
800	900	-100	0	+112	+56	+156	+100	+190	+100	+266	+210	+300	+210
				-212	-56	-256	-100	-290	-100	-366	-210	-400	-210
				-192	-76	-236	-120	-263	-127	-346	-230	-373	-237
900	1000	-100	0	+112	+56	+156	+100	+190	+100	+276	+220	+310	+220
				-212	-56	-256	-100	-290	-100	-376	-220	-410	-220
				-192	-76	-236	-120	-263	-127	-356	-240	-383	-247
1000	1120	-125	0	+132	+66	+186	+120	+225	+120	+316	+250	+355	+250
				-257	-66	-311	-120	-350	-120	-441	-250	-480	-250
				-233	-90	-287	-144	-317	-153	-417	-274	-447	-283
1120	1250	-125	0	+132	+66	+186	+120	+225	+120	+326	+260	+365	+260
				-257	-66	-311	-120	-350	-120	-451	-260	-490	-260
				-233	-90	-287	-144	-317	-153	-427	-284	-457	-293
1250	1400	-160	0	+156	+78	+218	+140	+265	+140	+378	+300	+425	+300
				-316	-78	-378	-140	-425	-140	-538	-300	-585	-300
				-286	-108	-348	-170	-385	-180	-508	-330	-545	-340
1400	1600	-160	0	+156	+78	+218	+140	+265	+140	+408	+330	+455	+330
				-316	-78	-378	-140	-425	-140	-568	-330	-615	-330
				-286	-108	-348	-170	-385	-180	-538	-360	-575	-370
1600	1800	-200	0	+184	+92	+262	+170	+320	+170	+462	+370	+520	+370
				-384	-92	-462	-170	-520	-170	-662	-370	-720	-370
				-349	-127	-427	-205	-470	-220	-627	-405	-670	-420
1800	2000	-200	0	+184	+92	+262	+170	+320	+170	+492	+400	+550	+400
				-384	-92	-462	-170	-520	-170	-692	-400	-750	-400
				-349	-127	-427	-205	-470	-220	-657	-435	-700	-450

Values are valid for most bearings with Normal tolerances. For exceptions, refer to *Shaft and housing tolerances and fits* (→ page 171).

F

Table 7f

Shaft tolerances and resultant fits



Shaft		Bearing		Shaft diameter deviations, resultant fits			
Nominal diameter d		Bore diameter tolerance Δ _{dmp}		Tolerance classes			
				s6(⊖ _{min} ± IT6/2)		s7(⊖ _{min} ± IT7/2)	
over	incl.	low	high	Deviations (shaft diameter)			
				Theoretical interference (-)			
				Probable interference (-)			
mm		μm		μm			
200	225	-30	0	+144	+115	+153	+107
				-174	-115	-183	-107
				-166	-123	-173	-117
225	250	-30	0	+154	+125	+163	+117
				-184	-125	-193	-117
				-176	-133	-183	-127
250	280	-35	0	+174	+142	+184	+132
				-209	-142	-219	-132
				-200	-151	-207	-144
280	315	-35	0	+186	+154	+196	+144
				-221	-154	-231	-144
				-212	-163	-219	-156
315	355	-40	0	+208	+172	+218	+161
				-248	-172	-258	-161
				-237	-183	-245	-174
355	400	-40	0	+226	+190	+236	+179
				-266	-190	-276	-179
				-255	-201	-263	-192
400	450	-45	0	+252	+212	+263	+200
				-297	-212	-308	-200
				-285	-224	-293	-215
450	500	-45	0	+272	+232	+283	+220
				-317	-232	-328	-220
				-305	-244	-313	-235
500	560	-50	0	+302	+258	+315	+245
				-352	-258	-365	-245
				-339	-271	-349	-261
560	630	-50	0	+332	+288	+345	+275
				-382	-288	-395	-275
				-369	-301	-379	-291
630	710	-75	0	+365	+315	+380	+300
				-440	-315	-455	-300
				-423	-332	-433	-322
710	800	-75	0	+405	+355	+420	+340
				-480	-355	-495	-340
				-463	-372	-473	-362
800	900	-100	0	+458	+402	+475	+385
				-558	-402	-575	-385
				-538	-422	-548	-412

Values are valid for most bearings with Normal tolerances. For exceptions, refer to *Shaft and housing tolerances and fits* (→ page 171).

Table 7f

Shaft tolerances and resultant fits

Shaft		Bearing		Shaft diameter deviations, resultant fits			
Nominal diameter d		Bore diameter tolerance Δ_{dmp}		Tolerance classes			
				$s6(\ominus_{min} \pm IT6/2)$		$s7(\ominus_{min} \pm IT7/2)$	
				Deviations (shaft diameter)			
				Theoretical interference (-)			
				Probable interference (-)			
over	incl.	low	high	μm			
mm		μm		μm			
900	1000	-100	0	+498	+442	+515	+425
				-598	-442	-615	-425
				-578	-462	-588	-452
1000	1120	-125	0	+553	+487	+572	+467
				-678	-487	-697	-467
				-654	-511	-664	-500
1120	1250	-125	0	+613	+547	+632	+527
				-738	-547	-757	-527
				-714	-571	-724	-560
1250	1400	-160	0	+679	+601	+702	+577
				-839	-601	-862	-577
				-809	-631	-822	-617
1400	1600	-160	0	+759	+681	+782	+657
				-919	-681	-942	-657
				-889	-711	-902	-697
1600	1800	-200	0	+866	+774	+895	+745
				-1066	-774	-1095	-745
				-1031	-809	-1045	-795
1800	2000	-200	0	+966	+874	+995	+845
				-1166	-874	-1195	-845
				-1131	-909	-1145	-895

Values are valid for most bearings with Normal tolerances. For exceptions, refer to *Shaft and housing tolerances and fits* (→ page 171).

Table 8a

Housing tolerances and resultant fits



Housing		Bearing		Housing bore diameter deviations, resultant fits									
Nominal bore diameter D		Outside diameter tolerance Δ _{Dmp}		Tolerance classes									
				F7 [Ⓔ]	G6 [Ⓔ]	G7 [Ⓔ]	H5 [Ⓔ]	H6 [Ⓔ]					
				Deviations (housing bore diameter)									
				Theoretical clearance (+)									
				Probable clearance (+)									
over	incl.	high	low										
mm		μm		μm									
6	10	0	-8	+13	+28	+5	+14	+5	+20	0	+6	0	+9
				+13	+36	+5	+22	+5	+28	0	+14	0	+17
				+16	+33	+7	+20	+8	+25	+2	+12	+2	+15
10	18	0	-8	+16	+34	+6	+17	+6	+24	0	+8	0	+11
				+16	+42	+6	+25	+6	+32	0	+16	0	+19
				+19	+39	+8	+23	+9	+29	+2	+14	+2	+17
18	30	0	-9	+20	+41	+7	+20	+7	+28	0	+9	+0	+13
				+20	+50	+7	+29	+7	+37	0	+18	0	+22
				+23	+47	+10	+26	+10	+34	+2	+16	+3	+19
30	50	0	-11	+25	+50	+9	+25	+9	+34	0	+11	0	+16
				+25	+61	+9	+36	+9	+45	0	+22	0	+27
				+29	+57	+12	+33	+13	+41	+3	+19	+3	+24
50	80	0	-13	+30	+60	+10	+29	+10	+40	0	+13	0	+19
				+30	+73	+10	+42	+10	+53	0	+26	0	+32
				+35	+68	+14	+38	+15	+48	+3	+23	+4	+28
80	120	0	-15	+36	+71	+12	+34	+12	+47	0	+15	0	+22
				+36	+86	+12	+49	+12	+62	0	+30	0	+37
				+41	+81	+17	+44	+17	+57	+4	+26	+5	+32
120	150	0	-18	+43	+83	+14	+39	+14	+54	0	+18	0	+25
				+43	+101	+14	+57	+14	+72	0	+36	0	+43
				+50	+94	+20	+51	+21	+65	+5	+31	+6	+37
150	180	0	-25	+43	+83	+14	+39	+14	+54	0	+18	0	+25
				+43	+108	+14	+64	+14	+79	0	+43	0	+50
				+51	+100	+21	+57	+22	+71	+6	+37	+7	+43
180	250	0	-30	+50	+96	+15	+44	+15	+61	0	+20	0	+29
				+50	+126	+15	+74	+15	+91	0	+50	0	+59
				+60	+116	+23	+66	+25	+81	+6	+44	+8	+51
250	315	0	-35	+56	+108	+17	+49	+17	+69	0	+23	0	+32
				+56	+143	+17	+84	+17	+104	0	+58	0	+67
				+68	+131	+26	+75	+29	+92	+8	+50	+9	+58
315	400	0	-40	+62	+119	+18	+54	+18	+75	0	+25	0	+36
				+62	+159	+18	+94	+18	+115	0	+65	0	+76
				+75	+146	+29	+83	+31	+102	+8	+57	+11	+65
400	500	0	-45	+68	+131	+20	+60	+20	+83	0	+27	0	+40
				+68	+176	+20	+105	+20	+128	0	+72	0	+85
				+83	+161	+32	+93	+35	+113	+9	+63	+12	+73
500	630	0	-50	+76	+146	+22	+66	+22	+92	0	+28	0	+44
				+76	+196	+22	+116	+22	+142	0	+78	0	+94
				+92	+180	+35	+103	+38	+126	+10	+68	+13	+81

Values are valid for most bearings with Normal tolerances. For exceptions, refer to *Shaft and housing tolerances and fits* (→ page 171).

Table 8a

Housing tolerances and resultant fits



Housing		Bearing		Housing bore diameter deviations, resultant fits									
Nominal bore diameter D		Outside diameter tolerance $\Delta_{D_{mp}}$		Tolerance classes									
				F7 [Ⓔ]		G6 [Ⓔ]		G7 [Ⓔ]		H5 [Ⓔ]		H6 [Ⓔ]	
				Deviations (housing bore diameter)									
				Theoretical clearance (+)									
				Probable clearance (+)									
over	incl.	high	low	μm									
mm		μm		μm									
630	800	0	-75	+80	+160	+24	+74	+24	+104	0	+32	0	+50
				+80	+235	+24	+149	+24	+179	0	+107	0	+125
				+102	+213	+41	+132	+46	+157	+12	+95	+17	+108
800	1000	0	-100	+86	+176	+26	+82	+26	+116	0	+36	0	+56
				+86	+276	+26	+182	+26	+216	0	+136	0	+156
				+113	+249	+46	+162	+53	+189	+14	+122	+20	+136
1000	1250	0	-125	+98	+203	+28	+94	+28	+133	0	+42	0	+66
				+98	+328	+28	+219	+28	+258	0	+167	0	+191
				+131	+295	+52	+195	+61	+225	+17	+150	+24	+167
1250	1600	0	-160	+110	+235	+30	+108	+30	+155	0	+50	0	+78
				+110	+395	+30	+268	+30	+315	0	+210	0	+238
				+150	+355	+60	+238	+70	+275	+21	+189	+30	+208
1600	2000	0	-200	+120	+270	+32	+124	+32	+182	0	+60	0	+92
				+120	+470	+32	+324	+32	+382	0	+260	0	+292
				+170	+420	+67	+289	+82	+332	+25	+235	+35	+257
2000	2500	0	-250	+130	+305	+34	+144	+34	+209	0	+70	0	+110
				+130	+555	+34	+394	+34	+459	0	+320	0	+360
				+189	+496	+77	+351	+93	+400	+30	+290	+43	+317

Values are valid for most bearings with Normal tolerances. For exceptions, refer to *Shaft and housing tolerances and fits* (→ page 171).

F

Table 8b

Housing tolerances and resultant fits

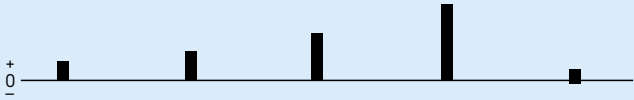

Housing		Bearing		Housing bore diameter deviations, resultant fits									
Nominal bore diameter D		Outside diameter tolerance Δ _{Dmp}		Tolerance classes									
				H7(E)	H8(E)	H9(E)	H10(E)	J6(E)					
				Deviations (housing bore diameter)									
				Theoretical interference (-)/clearance (+)									
				Probable interference (-)/clearance (+)									
over	incl.	high	low										
mm		µm		µm									
6	10	0	-8	0	+15	0	+22	0	+36	0	+58	-4	+5
				0	+23	0	+30	0	+44	0	+66	-4	+13
				+3	+20	+3	+27	+3	+41	+3	+63	-2	+11
10	18	0	-8	0	+18	0	+27	0	+43	0	+70	-5	+6
				0	+26	0	+35	0	+51	0	+78	-5	+14
				+3	+23	+3	+32	+3	+48	+3	+75	-3	+12
18	30	0	-9	0	+21	0	+33	0	+52	0	+84	-5	+8
				0	+30	0	+42	0	+61	0	+93	-5	+17
				+3	+27	+3	+39	+4	+57	+4	+99	-2	+14
30	50	0	-11	0	+25	0	+39	0	+62	0	+100	-6	+10
				0	+36	0	+50	0	+73	0	+111	-6	+21
				+4	+32	+4	+46	+5	+68	+5	+106	-3	+18
50	80	0	-13	0	+30	0	+46	0	+74	0	+120	-6	+13
				0	+43	0	+59	0	+87	0	+133	-6	+26
				+5	+38	+5	+54	+5	+82	+6	+127	-2	+22
80	120	0	-15	0	+35	0	+54	0	+87	0	+140	-6	+16
				0	+50	0	+69	0	+102	0	+155	-6	+31
				+5	+45	+6	+63	+6	+96	+7	+148	-1	+26
120	150	0	-18	0	+40	0	+63	0	+100	0	+160	-7	+18
				0	+58	0	+81	0	+118	0	+178	-7	+36
				+7	+51	+7	+74	+8	+110	+8	+170	-1	+30
150	180	0	-25	0	+40	0	+63	0	+100	0	+160	-7	+18
				0	+65	0	+88	0	+125	0	+185	-7	+43
				+8	+57	+10	+78	+10	+115	+11	+174	0	+36
180	250	0	-30	0	+46	0	+72	0	+115	0	+185	-7	+22
				0	+76	0	+102	0	+145	0	+215	-7	+52
				+10	+66	+12	+90	+13	+132	+13	+202	+1	+44
250	315	0	-35	0	+52	0	+81	0	+130	0	+210	-7	+25
				0	+87	0	+116	0	+165	0	+245	-7	+60
				+12	+75	+13	+103	+15	+150	+16	+229	+2	+51
315	400	0	-40	0	+57	0	+89	0	+140	0	+230	-7	+29
				0	+97	0	+129	0	+180	0	+270	-7	+69
				+13	+84	+15	+114	+17	+163	+18	+252	+4	+58
400	500	0	-45	0	+63	0	+97	0	+155	0	+250	-7	+33
				0	+108	0	+142	0	+200	0	+295	-7	+78
				+15	+93	+17	+125	+19	+181	+20	+275	+5	+66
500	630	0	-50	0	+70	0	+110	0	+175	0	+280	-	-
				0	+120	0	+160	0	+225	0	+330	-	-
				+16	+104	+19	+141	+21	+204	+22	+308	-	-

Values are valid for most bearings with Normal tolerances. For exceptions, refer to *Shaft and housing tolerances and fits* (→ page 171).

Table 8b

Housing tolerances and resultant fits

Housing		Bearing		Housing bore diameter deviations, resultant fits									
Nominal bore diameter D		Outside diameter tolerance $\Delta_{D_{mp}}$		Tolerance classes									
over	incl.	high	low	H7 \oplus		H8 \oplus		H9 \oplus		H10 \oplus		J6 \ominus	
				Deviations (housing bore diameter)									
				Theoretical interference (-)/clearance (+)									
				Probable interference (-)/clearance (+)									
mm		μm		μm									
630	800	0	-75	0	+80	0	+125	0	+200	0	+320	-	-
				0	+155	0	+200	0	+275	0	+395	-	-
				+22	+133	+27	+173	+30	+245	+33	+362	-	-
800	1000	0	-100	0	+90	0	+140	0	+230	0	+360	-	-
				0	+190	0	+240	0	+330	0	+460	-	-
				+27	+163	+33	+207	+39	+291	+43	+417	-	-
1000	1250	0	-125	0	+105	0	+165	0	+260	0	+420	-	-
				0	+230	0	+290	0	+385	0	+545	-	-
				+33	+197	+41	+249	+48	+337	+53	+492	-	-
1250	1600	0	-160	0	+125	0	+195	0	+310	0	+500	-	-
				0	+285	0	+355	0	+470	0	+660	-	-
				+40	+245	+51	+304	+60	+410	+67	+593	-	-
1600	2000	0	-200	0	+150	0	+230	0	+370	0	+600	-	-
				0	+350	0	+430	0	+570	0	+800	-	-
				+50	+300	+62	+368	+74	+496	+83	+717	-	-
2000	2500	0	-250	0	+175	0	+280	0	+440	0	+700	-	-
				0	+425	0	+530	0	+690	0	+950	-	-
				+59	+366	+77	+453	+91	+599	+103	+847	-	-

Values are valid for most bearings with Normal tolerances. For exceptions, refer to *Shaft and housing tolerances and fits* (→ page 171).



Table 8c

Housing tolerances and resultant fits

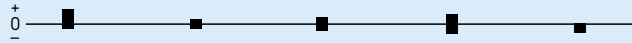

Housing Nominal bore diameter D	Bearing Outside diameter tolerance $\Delta_{D_{mp}}$	Housing bore diameter deviations, resultant fits																																			
		Tolerance classes																																			
				J7(E)		J5(E)		J56(E)		J57(E)		K5(E)																									
		Deviations (housing bore diameter)		Theoretical interference (-)/clearance (+)																																	
		over incl.		Probable interference (-)/clearance (+)																																	
mm	μm	μm	μm	μm																																	
6	10	0	-8	-7	+8	-3	+3	-4,5	+4,5	-7,5	+7,5	-5	+1	-7	+16	-3	+11	-4,5	+12,5	-7,5	+15,5	-5	+9	-4	+13	-1	+9	-3	+11	-5	+13	-3	+7				
				10	18	0	-8	-8	+10	-4	+4	-5,5	+5,5	-9	+9	-6	+2	-8	+18	-4	+12	-5,5	+13,5	-9	+17	-6	+10	-5	+15	-2	+10	-3	+11	-6	+14	-4	+8
								18	30	0	-9	-9	+12	-4,5	+4,5	-6,5	+6,5	-10,5	+10,5	-8	+1	-9	+21	-4,5	+13,5	-6,5	+15,5	-10,5	+19,5	-8	+10	-6	+18	-2	+11	-4	+13
30	50	0	-11	-11	+14	-5,5	+5,5					-8	+8	-12,5	+12,5	-9	+2	-11	+25	-5,5	+16,5	-8	+19	-12,5	+23,5	-9	+13	-7	+21	-3	+14	-5	+16	-9	+20	-6	+10
				50	80	0	-13	-12	+18	-6,5	+6,5	-9,5	+9,5	-15	+15	-10	+3	-12	+31	-6,5	+19,5	-9,5	+22,5	-15	+28	-10	+16	-7	+26	-3	+16	-6	+19	-10	+23	-7	+13
								80	120	0	-15	-13	+22	-7,5	+7,5	-11	+11	-17,5	+17,5	-13	+2	-13	+37	-7,5	+22,5	-11	+26	-17,5	+32,5	-13	+17	-8	+32	-4	+19	-6	+21
120	150	0	-18	-14	+26	-9	+9					-12,5	+12,5	-20	+20	-15	+3	-14	+44	-9	+27	-12,5	+30,5	-20	+38	-15	+21	-7	+37	-4	+22	-7	+25	-13	+31	-10	+16
				150	180	0	-25					-14	+26	-9	+9	-12,5	+12,5	-20	+20	-15	+3	-14	+51	-9	+34	-12,5	+37,5	-20	+45	-15	+28	-6	+43	-3	+28	-6	+31
180	250	0	-30					-16	+30	-10	+10	-14,5	+14,5	-23	+23	-18	+2	-16	+60	-10	+40	-14,5	+44,5	-23	+53	-18	+32	-6	+50	-4	+34	-6	+36	-13	+43	-12	+26
								250	315	0	-35	-16	+36	-11,5	+11,5	-16	+16	-26	+26	-20	+3	-16	+71	-11,5	+46,5	-16	+51	-26	+61	-20	+38	-4	+59	-4	+39	-7	+42
315	400	0	-40	-18	+39	-12,5	+12,5					-18	+18	-28,5	+28,5	-22	+3	-18	+79	-12,5	+52,5	-18	+58	-28,5	+68,5	-22	+43	-5	+66	-4	+44	-7	+47	-15	+55	-14	+35
				400	500	0	-45					-20	+43	-13,5	+13,5	-20	+20	-31,5	+31,5	-25	+2	-20	+88	-13,5	+58,5	-20	+65	-31,5	+76,5	-25	+47	-5	+73	-4	+49	-8	+53
500	630	0	-50					-	-	-14	+14	-22	+22	-35	+35	-	-	-	-	-14	+14	-22	+22	-35	+35	-	-	-	-	-4	+54	-9	+59	-19	+69	-	-
								-	-	-	-	-	-	-	-	-	-	-	-	-	-	-	-	-	-	-	-	-	-								

Values are valid for most bearings with Normal tolerances. For exceptions, refer to *Shaft and housing tolerances and fits* (→ page 171).

Table 8c

Housing tolerances and resultant fits

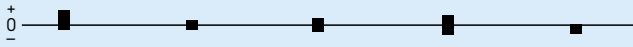

Housing Nominal bore diameter D		Bearing Outside diameter tolerance Δ_{Dmp}		Housing bore diameter deviations, resultant fits																													
				Tolerance classes																													
				J7(E)		J5(E)		J6(E)		J7(E)		K5(E)																					
				Deviations (housing bore diameter)																													
				Theoretical interference (-)/clearance (+)																													
				Probable interference (-)/clearance (+)																													
over	incl.	high	low	μm																													
mm		μm		μm																													
630	800	0	-75	-	-	-16	+16	-25	+25	-40	+40	-	-	-	-	-16	+91	-25	+100	-40	+115	-	-	-	-	-4	+79	-8	+83	-18	+93	-	-
				-	-	-18	+18	-28	+28	-45	+45	-	-	-	-	-18	+118	-28	+128	-45	+145	-	-	-	-	-4	+104	-8	+108	-18	+118	-	-
				-	-	-21	+21	-33	+33	-52	+52	-	-	-	-	-21	+146	-33	+158	-52	+177	-	-	-	-	-4	+129	-9	+134	-20	+145	-	-
1250	1600	0	-160	-	-	-25	+25	-39	+39	-62	+62	-	-	-	-	-25	+185	-39	+199	-62	+222	-	-	-	-	-4	+164	-9	+169	-22	+182	-	-
				-	-	-30	+30	-46	+46	-75	+75	-	-	-	-	-30	+230	-46	+246	-75	+275	-	-	-	-	-5	+205	-11	+211	-25	+225	-	-
				-	-	-35	+35	-55	+55	-87	+87	-	-	-	-	-35	+285	-55	+305	-87	+337	-	-	-	-	-5	+255	-12	+262	-28	+278	-	-
2000	2500	0	-250	-	-	-30	+30	-46	+46	-75	+75	-	-	-	-	-30	+230	-46	+246	-75	+275	-	-	-	-	-5	+205	-11	+211	-25	+225	-	-
				-	-	-35	+35	-55	+55	-87	+87	-	-	-	-	-35	+285	-55	+305	-87	+337	-	-	-	-	-5	+255	-12	+262	-28	+278	-	-
				-	-	-35	+35	-55	+55	-87	+87	-	-	-	-	-35	+285	-55	+305	-87	+337	-	-	-	-	-5	+255	-12	+262	-28	+278	-	-

Values are valid for most bearings with Normal tolerances. For exceptions, refer to *Shaft and housing tolerances and fits* (→ page 171).

F

Table 8d

Housing tolerances and resultant fits

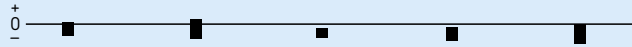

Housing		Bearing		Housing bore diameter deviations, resultant fits																																	
Nominal bore diameter D		Outside diameter tolerance Δ_{Dmp}		Tolerance classes																																	
				K6(Ⓔ)		K7(Ⓔ)		M5(Ⓔ)		M6(Ⓔ)		M7(Ⓔ)																									
				Deviations (housing bore diameter)																																	
				Theoretical interference (-)/clearance (+)																																	
				Probable interference (-)/clearance (+)																																	
over	incl.	high	low																																		
mm		μm		μm																																	
6	10	0	-8	-7	+2	-10	+5	-10	-4	-12	-3	-15	0	-7	+10	-10	+13	-10	+4	-12	+5	-15	+8	-5	+8	-7	+10	-8	+2	-10	+3	-12	+5				
				10	18	0	-8	-9	+2	-12	+6	-12	-4	-15	-4	-18	0	-9	+10	-12	+14	-12	+4	-15	+4	-18	+8	-7	+8	-9	+11	-10	+2	-13	+2	-15	+5
								18	30	0	-9	-11	+2	-15	+6	-14	-4	-17	-4	-21	0	-11	+11	-15	+15	-14	+4	-17	+5	-21	+9	-8	+8	-12	+12	-12	+2
30	50	0	-11	-13	+3	-18	+7					-16	-5	-20	-4	-25	0	-13	+14	-18	+18	-16	+6	-20	+7	-25	+11	-10	+11	-14	+14	-13	+3	-17	+4	-21	+7
				50	80	0	-13	-15	+4	-21	+9	-19	-6	-24	-5	-30	0	-15	+17	-21	+22	-19	+7	-24	+8	-30	+13	-11	+13	-16	+17	-16	+4	-20	+4	-25	+8
								80	120	0	-15	-18	+4	-25	+10	-23	-8	-28	-6	-35	0	-18	+19	-25	+25	-23	+7	-28	+9	-35	+15	-13	+14	-20	+20	-19	+3
120	150	0	-18	-21	+4	-28	+12					-27	-9	-33	-8	-40	0	-21	+22	-28	+30	-27	+9	-33	+10	-40	+18	-15	+16	-21	+23	-22	+4	-27	+4	-33	+11
				150	180	0	-25	-21	+4	-28	+12	-27	-9	-33	-8	-40	0	-21	+29	-28	+37	-27	+16	-33	+17	-40	+25	-14	+22	-20	+29	-21	+10	-26	+10	-32	+17
								180	250	0	-30	-24	+5	-33	+13	-31	-11	-37	-8	-46	0	-24	+35	-33	+43	-31	+19	-37	+22	-46	+30	-16	+27	-23	+33	-25	+13
250	315	0	-35	-27	+5	-36	+16					-36	-13	-41	-9	-52	0	-27	+40	-36	+51	-36	+22	-41	+26	-52	+35	-18	+31	-24	+39	-28	+14	-32	+17	-40	+23
				315	400	0	-40	-29	+7	-40	+17	-39	-14	-46	-10	-57	0	-29	+47	-40	+57	-39	+26	-46	+30	-57	+40	-18	+36	-27	+44	-31	+18	-35	+19	-44	+27
								400	500	0	-45	-32	+8	-45	+18	-43	-16	-50	-10	-63	0	-32	+53	-45	+63	-43	+29	-50	+35	-63	+45	-20	+41	-30	+48	-34	+20
500	630	0	-50	-44	0	-70	0					-	-	-70	-26	-96	-26	-44	+50	-70	+50	-	-	-70	+24	-96	+24	-31	+37	-54	+34	-	-	-57	+11	-80	+8

Values are valid for most bearings with Normal tolerances. For exceptions, refer to *Shaft and housing tolerances and fits* (→ page 171).

Table 8d

Housing tolerances and resultant fits

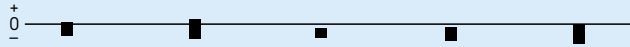

Housing		Bearing		Housing bore diameter deviations, resultant fits									
Nominal bore diameter D		Outside diameter tolerance Δ_{Dmp}		Tolerance classes									
				K6	K7		M5		M6		M7		
				Deviations (housing bore diameter)									
				Theoretical interference (-)/clearance (+)									
				Probable interference (-)/clearance (+)									
over	incl.	high	low	μm									
mm		μm		μm									
630	800	0	-75	-50	0	-80	0	-	-	-80	-30	-110	-30
				-50	+75	-80	+75	-	-	-80	+45	-110	+45
				-33	+58	-58	+53	-	-	-63	+28	-88	+23
800	1000	0	-100	-56	0	-90	0	-	-	-90	-34	-124	-34
				-56	+100	-90	+100	-	-	-90	+66	-124	+66
				-36	+80	-63	+73	-	-	-70	+46	-97	+39
1000	1250	0	-125	-66	0	-105	0	-	-	-106	-40	-145	-40
				-66	+125	-105	+125	-	-	-106	+85	-145	+85
				-42	+101	-72	+92	-	-	-82	+61	-112	+52
1250	1600	0	-160	-78	0	-125	0	-	-	-126	-48	-173	-48
				-78	+160	-125	+160	-	-	-126	+112	-173	+112
				-48	+130	-85	+120	-	-	-96	+82	-133	+72
1600	2000	0	-200	-92	0	-150	0	-	-	-158	-58	-208	-58
				-92	+200	-150	+200	-	-	-150	+142	-208	+142
				-57	+165	-100	+150	-	-	-115	+107	-158	+92
2000	2500	0	-250	-110	0	-175	0	-	-	-178	-68	-243	-68
				-110	+250	-175	+250	-	-	-178	+182	-243	+182
				-67	+207	-116	+191	-	-	-135	+139	-184	+123

Values are valid for most bearings with Normal tolerances. For exceptions, refer to *Shaft and housing tolerances and fits* (→ page 171).



Table 8e

Housing tolerances and resultant fits



Housing		Bearing		Housing bore diameter deviations, resultant fits							
Nominal bore diameter D		Outside diameter tolerance Δ _{Dmp}		Tolerance classes							
				N6 [Ⓔ]		N7 [Ⓔ]		P6 [Ⓔ]		P7 [Ⓔ]	
over	incl.	high	low	Deviations (housing bore diameter)							
				Theoretical interference (-)/clearance (+)							
				Probable interference (-)/clearance (+)							
mm		μm		μm							
6	10	0	-8	-16	-7	-19	-4	-21	-12	-24	-9
				-16	+1	-19	+4	-21	-4	-24	-1
				-14	-1	-16	+1	-19	-6	-21	-4
10	18	0	-8	-20	-9	-23	-5	-26	-15	-29	-11
				-20	-1	-23	+3	-26	-7	-29	-3
				-18	-3	-20	0	-24	-9	-26	-6
18	30	0	-9	-24	-11	-28	-7	-31	-18	-35	-14
				-24	-2	-28	+2	-31	-9	-35	-5
				-21	-5	-25	-1	-28	-12	-32	-8
30	50	0	-11	-28	-12	-33	-8	-37	-21	-42	-17
				-28	-1	-33	+3	-37	-10	-42	-6
				-25	-4	-29	-1	-34	-13	-38	-10
50	80	0	-13	-33	-14	-39	-9	-45	-26	-51	-21
				-33	-1	-39	+4	-45	-13	-51	-8
				-29	-5	-34	-1	-41	-17	-46	-13
80	120	0	-15	-38	-16	-45	-10	-52	-30	-59	-24
				-38	-1	-45	+5	-52	-15	-59	-9
				-33	-6	-40	0	-47	-20	-54	-14
120	150	0	-18	-45	-20	-52	-12	-61	-36	-68	-28
				-45	-2	-52	+6	-61	-18	-68	-10
				-39	-8	-45	-1	-55	-24	-61	-17
150	180	0	-25	-45	-20	-52	-12	-61	-36	-68	-28
				-45	+5	-52	+13	-61	-11	-68	-3
				-38	-2	-44	+5	-54	-18	-60	-11
180	250	0	-30	-51	-22	-60	-14	-70	-41	-79	-33
				-51	+8	-60	+16	-70	-11	-79	-3
				-43	0	-50	+6	-62	-19	-69	-13
250	315	0	-35	-57	-25	-66	-14	-79	-47	-88	-36
				-57	+10	-66	+21	-79	-12	-88	-1
				-48	+1	-54	+9	-70	-21	-76	-13
315	400	0	-40	-62	-26	-73	-16	-87	-51	-98	-41
				-62	+14	-73	+24	-87	-11	-98	-1
				-51	+3	-60	+11	-76	-22	-85	-14
400	500	0	-45	-67	-27	-80	-17	-95	-55	-108	-45
				-67	+18	-80	+28	-95	-10	-108	0
				-55	+6	-65	+13	-83	-22	-93	-15
500	630	0	-50	-88	-44	-114	-44	-122	-78	-148	-78
				-88	+6	-114	+6	-122	-28	-148	-28
				-75	-7	-98	-10	-109	-41	-132	-44

Values are valid for most bearings with Normal tolerances. For exceptions, refer to *Shaft and housing tolerances and fits* (→ page 171).

Table 8e

Housing tolerances and resultant fits

Housing Nominal bore diameter D		Bearing Outside diameter tolerance Δ_{Dmp}		Housing bore diameter deviations, resultant fits Tolerance classes							
				N6 [Ⓔ]	N7 [Ⓔ]		P6 [Ⓔ]		P7 [Ⓔ]		
				Deviations (housing bore diameter)							
				Theoretical interference (-)/clearance (+)							
				Probable interference (-)/clearance (+)							
over	incl.	high	low	μm							
mm		μm		μm							
630	800	0	-75	-100	-50	-130	-50	-138	-88	-168	-88
				-100	+25	-130	+25	-138	-13	-168	-13
				-83	+8	-108	+3	-121	-30	-146	-35
800	1000	0	-100	-112	-56	-146	-56	-156	-100	-190	-100
				-112	+44	-146	+44	-156	0	-190	0
				-92	+24	-119	+17	-136	-20	-163	-27
1000	1250	0	-125	-132	-66	-171	-66	-186	-120	-225	-120
				-132	+59	-171	+59	-186	+5	-225	+5
				-108	+35	-138	+26	-162	-19	-192	-28
1250	1600	0	-160	-156	-78	-203	-78	-218	-140	-265	-140
				-156	+82	-203	+82	-218	+20	-265	+20
				-126	+52	-163	+42	-188	-10	-225	-20
1600	2000	0	-200	-184	-92	-242	-92	-262	-170	-320	-170
				-184	+108	-242	+108	-262	+30	-320	+30
				-149	+73	-192	+58	-227	-5	-270	-20
2000	2500	0	-250	-220	-110	-285	-110	-305	-195	-370	-195
				-220	+140	-285	+140	-305	+55	-370	+55
				-177	+97	-226	+81	-262	+12	-311	-4

Values are valid for most bearings with Normal tolerances. For exceptions, refer to *Shaft and housing tolerances and fits* (→ page 171).

F

Design considerations

Dimensional and geometrical tolerances of bearing seats and abutments

The tolerances for cylindrical bearing seats on shafts and in housings and the seats for thrust bearing washers and for their support surfaces (abutments for bearings provided by shaft and housing shoulders etc.) should correspond to the tolerance class of the bearings. Guideline values for the dimensional and geometrical tolerances are provided hereafter.

Dimensional tolerances

For bearings made to Normal tolerances, the dimensional tolerances for cylindrical seats should be, at the very minimum, IT6 grade for the shaft and IT7 for the housing. Where adapter or withdrawal sleeves are used, wider diameter tolerances (IT9 grade) can be permitted for shaft seats (→ **table 9**). The numerical values of standard IT tolerance grades in accordance with ISO 286-1 are listed in **table 10**. For bearings with higher dimensional accuracy, correspondingly tighter grades should be used.

Tolerances for total radial run-out

Depending on the application requirements, the total radial run-out tolerances as defined in ISO 1101 should be one to two IT grades tighter than the prescribed dimensional tolerance. For example, if the specifications require a shaft seat in accordance with a tolerance class m6 \oplus , the total radial run-out should be IT5 or IT4. The tolerance value t_3 for total radial run-out is obtained for an assumed shaft diameter of 150 mm from $t_3 = IT5/2 = 18/2 = 9 \mu\text{m}$. Guideline values for the tolerances for total radial run-out are listed in **table 11** (→ **page 202**).

When bearings are to be mounted on adapter or withdrawal sleeves, the total radial run-out of the sleeve seat should be IT5/2 for tolerance class h9 \oplus (→ **table 9**).

Tolerances for total axial run-out

Abutments for bearing rings should have a total axial run-out tolerance as defined in ISO 1101, which is better by at least one IT grade than the diameter tolerance of the associated cylindrical seat. For thrust bearing washer seats, the tolerance for total axial run-out should not exceed IT5. Guideline values for the tolerances for total axial run-out are listed in **table 11** (→ **page 202**).

Table 9

Shaft diameter and geometrical tolerances for sleeve mounting

Shaft diameter d		Diameter tolerance h9(ES)		Total radial run-out IT5/2
Nominal over	incl.	Deviations high	low	max.
mm		µm		µm
10	18	0	-43	4
18	30	0	-52	5
30	50	0	-62	6
50	80	0	-74	7
80	120	0	-87	8
120	180	0	-100	9
180	250	0	-115	10
250	315	0	-130	12
315	400	0	-140	13
400	500	0	-155	14
500	630	0	-175	16
630	800	0	-200	18
800	1 000	0	-230	20
1 000	1 250	0	-260	24

Table 10

Values of ISO standard tolerance grades

Nominal dimension		Tolerance grades											
over	incl.	IT1 max.	IT2	IT3	IT4	IT5	IT6	IT7	IT8	IT9	IT10	IT11	IT12
mm		µm											
1	3	0,8	1,2	2	3	4	6	10	14	25	40	60	100
3	6	1	1,5	2,5	4	5	8	12	18	30	48	75	120
6	10	1	1,5	2,5	4	6	9	15	22	36	58	90	150
10	18	1,2	2	3	5	8	11	18	27	43	70	110	180
18	30	1,5	2,5	4	6	9	13	21	33	52	84	130	210
30	50	1,5	2,5	4	7	11	16	25	39	62	100	160	250
50	80	2	3	5	8	13	19	30	46	74	120	190	300
80	120	2,5	4	6	10	15	22	35	54	87	140	220	350
120	180	3,5	5	8	12	18	25	40	63	100	160	250	400
180	250	4,5	7	10	14	20	29	46	72	115	185	290	460
250	315	6	8	12	16	23	32	52	81	130	210	320	520
315	400	7	9	13	18	25	36	57	89	140	230	360	570
400	500	8	10	15	20	27	40	63	97	155	250	400	630
500	630	-	-	-	-	32	44	70	110	175	280	440	700
630	800	-	-	-	-	36	50	80	125	200	320	500	800
800	1 000	-	-	-	-	40	56	90	140	230	360	560	900
1 000	1 250	-	-	-	-	47	66	105	165	260	420	660	1050
1 250	1 600	-	-	-	-	55	78	125	195	310	500	780	1250
1 600	2 000	-	-	-	-	65	92	150	230	370	600	920	1 500
2 000	2 500	-	-	-	-	78	110	175	280	440	700	1 100	1 750

F

Design considerations

Tolerances for tapered shaft seats

When a bearing is mounted directly onto a tapered shaft seat, the tolerance grade of the diameter of the shaft seat can be wider than the tolerance grade for a cylindrical seat.

Fig. 18 shows an IT9 grade diameter tolerance, while the stipulated geometrical tolerance is the same as for a cylindrical shaft seat. For rolling bearings mounted on tapered shaft seats, SKF recommends:

- The permissible deviation for the slope of the taper should be a \pm tolerance in accordance with IT7/2, and is based on the bearing width B (\rightarrow **fig. 18**). For design purposes, the tolerance value has to be expressed in degrees. The value can be determined using

$$\Delta_k = \frac{IT7/2}{B}$$

Table 11

Geometrical tolerances for bearing seats on shafts and in housings

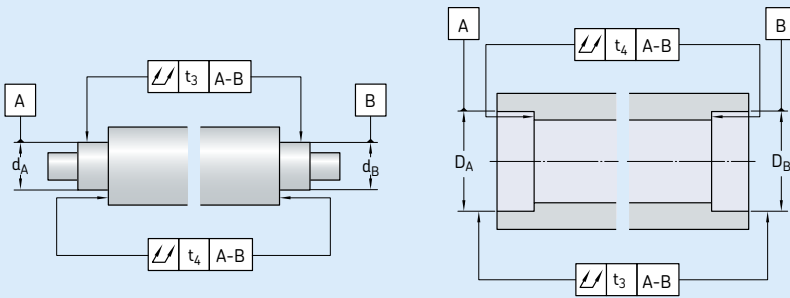

Surface Characteristic	Symbol for geometrical characteristic	tolerance zone	Permissible deviations Bearings of tolerance class ¹⁾		
			Normal, CLN	P6	P5

Cylindrical seat

Total radial run-out		t ₃	IT5/2	IT4/2	IT3/2	IT2/2
----------------------	--	----------------	-------	-------	-------	-------

Flat abutment

Total axial run-out		t ₄	IT5	IT4	IT3	IT2
---------------------	--	----------------	-----	-----	-----	-----

Explanation

	For normal demands	For special demands with respect to running accuracy or even support
--	--------------------	--

¹⁾ For bearings with a tolerance class higher than Normal (tolerance class P4 etc.), refer to *Super-precision bearings* (\rightarrow skf.com/super-precision).

The permissible deviation for the slope of the taper can be determined using

$$V_k = 1/k \pm \frac{IT7/2}{B}$$

where

Δ_k = the permissible deviation of the slope of the taper

V_k = the permissible range of dispersion of the slope of the taper

B = bearing width [mm]

IT7 = the value of the tolerance grade, based on the bearing width [mm]

k = factor for the taper

– for taper 1:12, $k = 12$

– for taper 1:30, $k = 30$

- The straightness tolerance grade IT5/2, based on the diameter d , is defined as: “In each axial plane through the tapered surface of the shaft, the tolerance zone is limited by two parallel lines a distance “ t ” apart.”

- The circularity tolerance grade IT5/2, based on the diameter d , is defined as distance “ t ” in each radial plane between two concentric circles along the tapered surface of the shaft. In applications where a high degree of running accuracy is required, IT4/2 should be used instead.

Only dimensional and geometrical tolerances of the taper are indicated in **fig. 18**. To locate the taper axially, individual specifications have to be provided.

To check whether a shaft taper is within its recommended tolerances, SKF recommends measuring it with a special taper gauge, based on two saddles. More practical, but less accurate measurement methods include ring gauges, taper gauges and sine bars. For information about SKF measuring devices such as RKM, 9205, GRA 30 series ring gauges and DMB taper gauges, contact the SKF application engineering service.

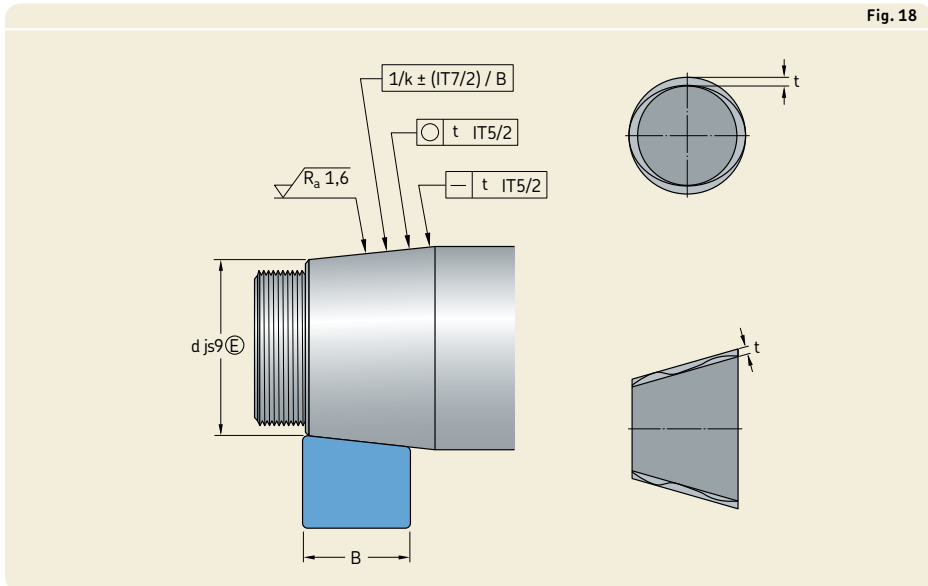

F

Table 12

Surface roughness of bearing seats				
Seat diameter		Recommended R_a value for ground seats		
d (D) ¹⁾		Diameter tolerance grade		
over	incl.	IT7	IT6	IT5
mm		µm		
-	80	1,6	0,8	0,4
80	500	1,6	1,6	0,8
500	1 250	3,2 ²⁾	1,6	1,6

¹⁾ For diameters > 1 250 mm, contact the SKF application engineering service.
²⁾ When using the oil injection method for mounting, R_a should not exceed 1,6 µm.

Surface roughness of bearing seats

The surface roughness of a bearing seat does not have the same degree of influence on bearing performance as the dimensional and geometrical tolerances of the seat. However, obtaining a desired interference fit depends on the roughness of the mating surfaces, which is directly proportional to fit accuracy. For less critical bearing arrangements a relatively rough surface finish is permitted.

Guideline values for the mean surface roughness R_a are listed in **table 12** for different bearing seat tolerance grades. These recommendations apply to ground seats, which are normally assumed for shaft seats.

Axial location of bearings

In general, an interference fit alone is inadequate to locate a bearing ring on a cylindrical seat. Under load and deflection, a bearing ring can creep on its seat. Some suitable means to secure the bearing axially are needed.

For a locating bearing, both rings should be secured axially on both sides.

For a non-separable bearing in the non-locating position, the ring with an interference fit, typically the inner ring, should be secured axially on both sides. The other ring must be free to move axially on its seat to accommodate axial displacement.

For non-locating bearings, CARB, cylindrical and needle roller bearings are exceptions. The inner and outer rings of these bearings must be secured axially in both directions.

For a cross-locating bearing system, each bearing ring needs to be secured axially on one side only.

Locating methods

Bearings with a cylindrical bore

Bearing rings that are mounted with an interference fit typically have one ring that abuts a shoulder on the shaft (→ **fig. 19**) or in the housing. On the opposite side, the inner ring is normally secured by a KM lock nut with an MB lock washer attached to the shaft end (→ **fig. 19**) or an end plate (→ **fig. 20**). Outer rings are typically located by a housing cover (→ **fig. 21**) or a threaded ring (→ **fig. 22**).

Fig. 20

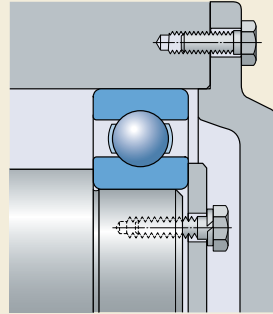

Fig. 21

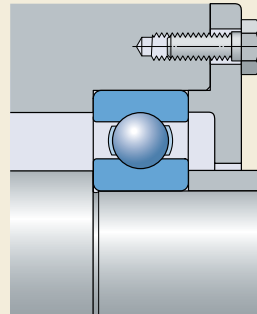

Fig. 19

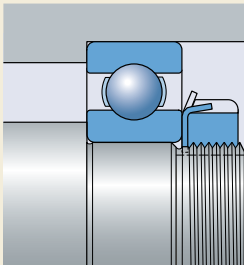
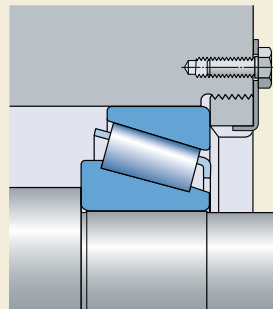

Fig. 22



Design considerations

Instead of integral shaft or housing shoulders, spacer sleeves or collars can be used between the bearing rings or between a bearing ring and an adjacent component, such as a gear (→ **fig. 23**).

The use of snap rings to locate rolling bearings axially, saves space, enables fast mounting and dismounting, and simplifies the machining of shafts and housing bores. If normal or heavy axial loads have to be supported, an abutment collar should be inserted between the bearing ring and snap ring, so that the snap ring is not subjected to excessive bending moments (→ **fig. 24**). The usual axial play between the snap ring and snap ring groove can be reduced, if necessary, by choosing suitable tolerances for the abutment collar or by using shims.

Another way to locate a bearing axially, which is typically found in super-precision bearing applications, is to use a stepped sleeve with a tight interference fit on the shaft. For detailed information, refer to *Super-precision bearings* (→ skf.com/super-precision).

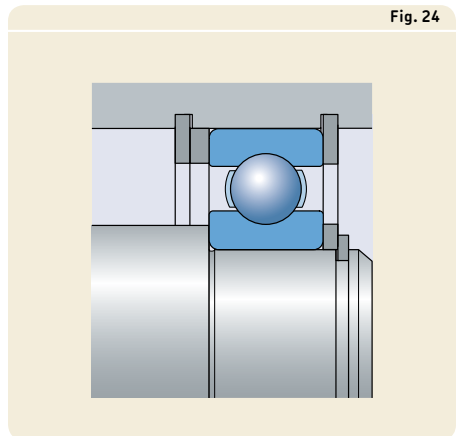
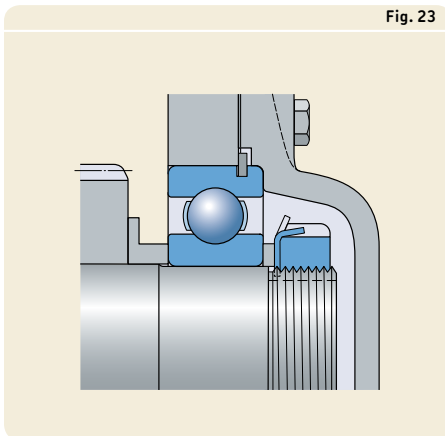

Bearings with a tapered bore

Bearings with a tapered bore, mounted directly on a tapered shaft seat, are typically located axially on the shaft by a lock nut (→ **fig. 25**).

When using an adapter sleeve on a stepped shaft, an L-shaped spacer ring, not supplied by SKF, is fitted between the shaft shoulder and inner ring on one side. A lock nut locates the bearing relative to the sleeve on the opposite side (→ **fig. 26**). Where plain shafts without integral abutments are used (→ **fig. 27**), the friction between the shaft and sleeve governs the axial load carrying capacity of the bearing (→ *Self-aligning ball bearings*, **page 537** and *Spherical roller bearings*, **page 879**).

When bearings are mounted on withdrawal sleeves, an abutment, such as a spacer ring, which is frequently designed as a labyrinth ring, must support the inner ring. The withdrawal sleeve is located axially by an end plate or lock nut (→ **fig. 28**).

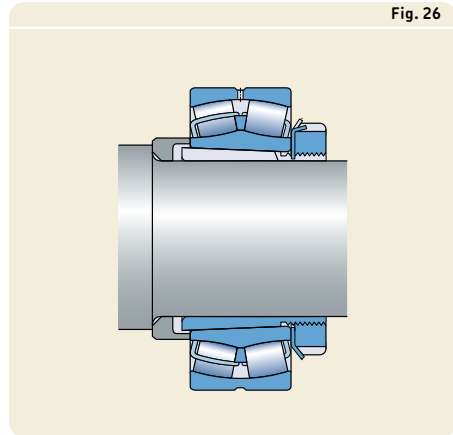

Fig. 26

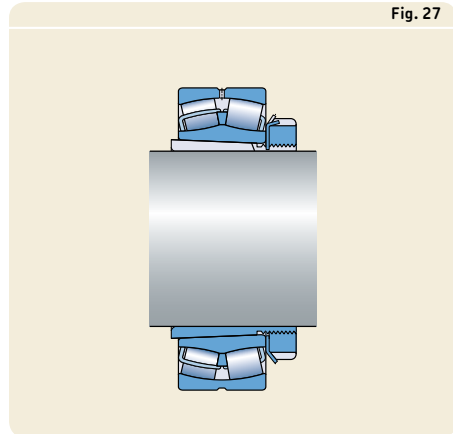

Fig. 27

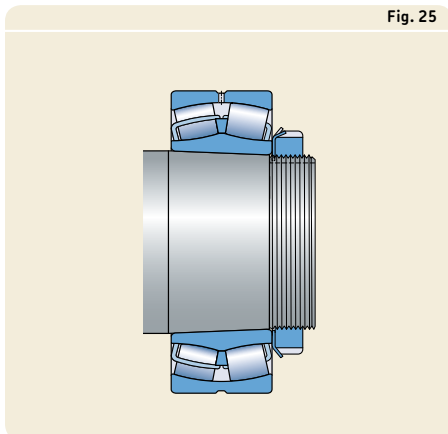

Fig. 25

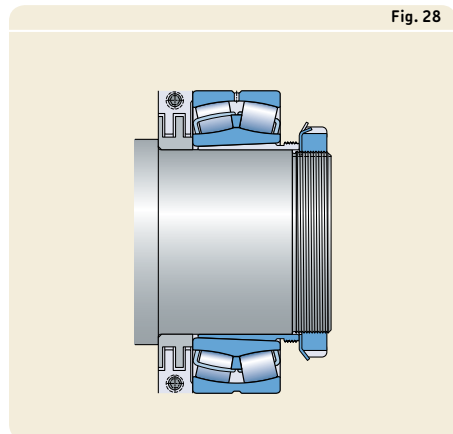

Fig. 28

F

Design considerations

Abutment and fillet dimensions

The dimensions of components adjacent to a bearing (such as shaft and housing shoulders, spacer sleeves) must be able to provide sufficient support for the bearing rings. However, there must not be any contact between the rotating parts of the bearing and a stationary adjacent component. Appropriate abutment and fillet dimensions are listed in the product tables.

The transition between the bearing seat and shaft or housing shoulder can be a fillet in accordance with the dimensions r_a and r_b in the product tables, or an undercut (\rightarrow table 13). As the fillet radius increases, the stress distribution in the fillet area improves. Therefore, heavily loaded shafts, which typically require a larger radius, use a spacing collar between the inner ring and shaft shoulder to provide a sufficiently large support surface for the bearing ring. The side of the collar that abuts the shaft shoulder should be designed so that it does not contact the fillet (\rightarrow fig. 29).

Table 13

Undercut dimensions

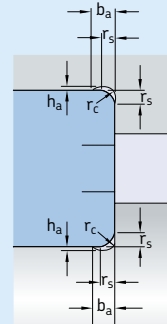

Bearing chamfer dimension

r_s	Undercut dimensions		
	b_a	h_a	r_c
mm	mm		
1	2	0,2	1,3
1,1	2,4	0,3	1,5
1,5	3,2	0,4	2
2	4	0,5	2,5
2,1	4	0,5	2,5
3	4,7	0,5	3
4	5,9	0,5	4
5	7,4	0,6	5
6	8,6	0,6	6
7,5	10	0,6	7
9,5	12	0,6	9

Fig. 29

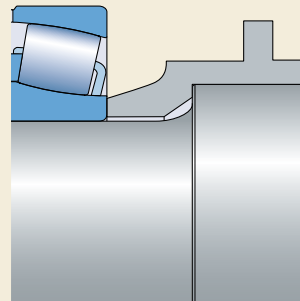

CARB toroidal roller bearings

CARB toroidal roller bearings can accommodate axial displacement of the shaft within the bearing. To be sure that displacement of the shaft relative to the housing can occur, sufficient space C_a must be provided on both sides of the bearing (→ **fig. 30**).

For additional information, refer to *CARB toroidal roller bearings* (→ **page 957**).

Fig. 30

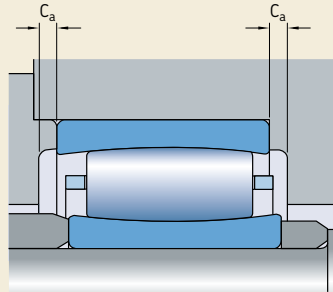

Design of associated components

Raceways on shafts and in housings

If the load carrying capacity of a bearing or assembly is to be fully exploited, the raceways machined in associated components for cylindrical and needle roller bearings with only one ring, must have a hardness between 58 and 64 HRC. The surface roughness should be $R_a \leq 0,2 \mu\text{m}$ or $R_z \leq 1 \mu\text{m}$. For less demanding applications, lower hardness and rougher surfaces may be used.

Roundness should be within 25% and the total radial run-out tolerance should be within 50% of the actual diameter tolerance range of the raceway.

The permissible axial run-out of the raceways for thrust assemblies are the same as for the shaft and housing washers of thrust bearings (→ **table 10, page 144**).

Suitable materials for the raceways include steels for through-hardening, such as 100Cr6 in accordance with ISO 683-17, steels for case-hardening, such as 20Cr3 or 17MnCr5 in accordance with ISO 683-17, as well as steels for induction-hardening that can be partially hardened.

The recommended case depth for raceways machined in associated components depends on various factors, including the dynamic and static load ratios (P/C and P_0/C_0 respectively) as well as the core hardness, which makes it difficult to generalize. For example, when core hardness is 350 HV, the recommended case depth is generally 0,1 times the rolling element diameter for purely static loads less than or equal to the basic static load rating. Shallower case depths are permitted for dynamic loads.

For additional information, contact the SKF application engineering service.

Provisions for mounting and dismounting

Particularly when large bearings are involved, SKF recommends making provisions during the design stage to facilitate mounting and dismounting. If, for example, slots or recesses are machined in the shaft and/or housing shoulders, it is possible to apply withdrawal tools (→ **fig. 31**). Threaded holes in the housing shoulders also enable the use of bolts to push or pull the bearing from its seat (→ **fig. 32**).

If the oil injection method is to be used to mount or dismount bearings on a tapered seat, or to dismount bearings from a cylindrical seat, ducts and grooves should be provided in the shaft (→ **fig. 33**). Recommended dimensions for the appropriate grooves, ducts and threaded holes to connect the oil supply are listed in **tables 14 and 15**.

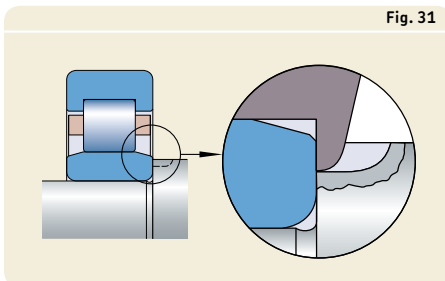

Fig. 31

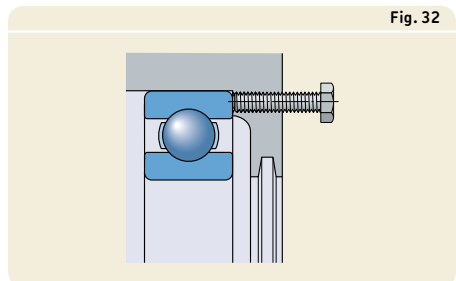

Fig. 32

Fig. 33

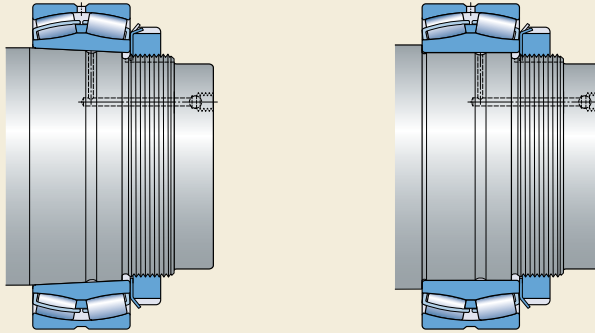
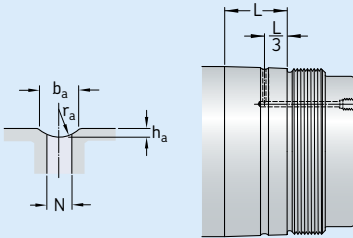

Table 14

Recommended dimensions for oil supply ducts and distribution grooves



Seat diameter		Dimensions			
over	incl.	b_a	h_a	r_a	N
mm		mm			
-	100	3	0,5	2,5	2,5
100	150	4	0,8	3	3
150	200	4	0,8	3	3
200	250	5	1	4	4
250	300	5	1	4	4
300	400	6	1,25	4,5	5
400	500	7	1,5	5	5
500	650	8	1,5	6	6
650	800	10	2	7	7
800	1 000	12	2,5	8	8

L = width of bearing seat

Table 15

Design and recommended dimensions for threaded holes for connecting oil supply

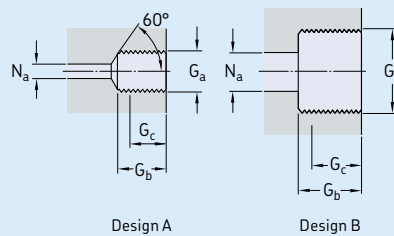

Thread	Design	Dimensions		
G_a		G_b	G_c ¹⁾	N_a max.
-		mm		
M 6	A	10	8	3
G 1/8	A	12	10	3
G 1/4	A	15	12	5
G 3/8	B	15	12	8
G 1/2	B	18	14	8
G 3/4	B	20	16	8

¹⁾ Effective threaded length



Selecting internal clearance or preload

The operating clearance or preload in a bearing is determined by:

- the initial internal clearance prior to mounting
- the actual fits or the distance a bearing is driven-up on a tapered seat
- the effects of form errors
- changes in the clearance or preload that result from mounting
- the dimensional changes resulting from the operating temperature

Shaft deflection and axial displacement, such as in CARB toroidal roller bearings, might also need to be considered.

The operating clearance or preload in a bearing influences friction, size of the load zone and fatigue life. **Diagram 2** shows the relationship between clearance and preload, and the primary parameters. The diagram is based on rolling bearings under radial load.

Diagram 2

Clearance and preload versus performance of primary parameters

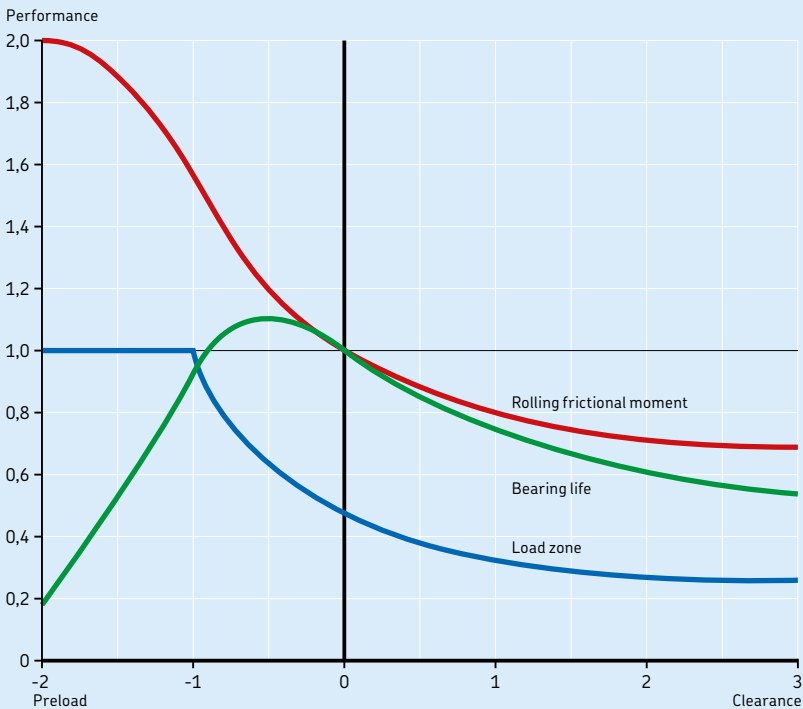

Clearance versus preload

For most applications, bearings operate with some residual clearance. Normally, a positive operating clearance near zero is the optimum (→ **diagram 2**).

A somewhat greater clearance may be more suitable for:

- high-speed applications to reduce frictional heat
- form errors on the shaft or housing seat such as ovality

The initial internal clearance prior to mounting and permissible reduction after mounting, depend on the type and size of the bearing. The reduction in clearance due to an interference fit may require greater initial internal clearance than Normal to avoid preloading the bearing (→ **fig. 15, page 167**).

Preload (negative operating clearance) has advantages, but can also be risky. If a high degree of stiffness is required, light preload can be suitable (→ *Bearing preload*, **page 214**).

A light preload may also be required when there is a very light or no external load on the bearing in operation.

However, there is a risk that too much preload causes the bearing to overheat, which further increases preload, friction and heat. This cycle can continue until the bearing seizes.

It could be argued that preload is acceptable, provided the bearing operates in a zone that does not exceed light preload (→ **diagram 2**, zone between 0 and -1). In this case, however, there is an increase in friction and frictional heat.

Although all bearing types can run with some preload, SKF recommends a positive operating clearance. This is particularly important for roller bearings such as cylindrical roller, needle roller, spherical roller and CARB toroidal roller bearings.

Bearing clearance

Selecting a clearance class

The clearance values listed in the relevant product chapters are valid for unmounted bearings. To select the best clearance value for an application, the required operating clearance in the bearing (in operation) must be determined first.

Because there are many factors that can influence operating clearance in a bearing, these calculations are best done with the aid of sophisticated computer programs. As a result, SKF recommends using one of the computer programs available through the SKF application engineering service. These programs consider tolerances, fits and component temperatures, to calculate the required initial internal clearance.

The required initial internal clearance of an unmounted bearing can be estimated using

$$r = r_{op} + \Delta r_{fit} + \Delta r_{temp}$$

where

r = required initial internal clearance for the unmounted bearing [mm]

r_{op} = desired operating clearance [mm]

Δr_{fit} = clearance reduction caused by the fit [mm]

Δr_{temp} = clearance reduction caused by temperature difference [mm]

Clearance reduction caused by an interference fit

The reduction equals the effective interference fit multiplied by a reduction factor using

$$\Delta r_{fit} = \Delta_1 f_1 + \Delta_2 f_2$$

where

Δr_{fit} = clearance reduction caused by the fit [mm]

f_1 = reduction factor for the inner ring

f_2 = reduction factor for the outer ring

Δ_1 = effective interference between the inner ring and shaft [mm]

Δ_2 = effective interference between the outer ring and housing [mm]



Design considerations

The reduction factors can be obtained from **diagram 3** as a function of the ratio of the bearing bore diameter d to the outside diameter D . It is valid for a solid steel shaft and a cast iron or steel housing. For the effective interference fit, the mean value of the smallest and largest values of the probable interference listed in **table 7** (→ **page 178**) and **table 8** (→ **page 190**) can be used.

Clearance reduction caused by a temperature difference between the bearing rings

When the inner ring temperature is higher than the outer ring temperature, the internal clearance within the bearing is reduced. The internal clearance reduction can be estimated using

$$\Delta r_{\text{temp}} = \alpha d_m \Delta T$$

where

Δr_{temp} = clearance reduction caused by temperature difference [mm]

d_m = bearing mean diameter [mm]
= $0,5 (d + D)$

α = thermal coefficient of expansion [$^{\circ}\text{C}^{-1}$]
for steel, $\alpha = 12 \times 10^{-6}$

ΔT = temperature difference between the shaft and housing [$^{\circ}\text{C}$]

The temperature difference between components during start-up can be much higher than under steady state conditions (→ **diagram 4**) and unwanted preload may result. It is important to avoid unwanted preload during start-up, because even short periods of preload can have a negative impact on bearing service life. One way to avoid excessive heat and the resulting preload is to start the application at a slow speed and increase the speed incrementally.

Bearing preload

Depending on the applications, there might be a need to preload the bearing arrangement i.e. apply a negative operating clearance.

In applications like machine tool spindles, automotive differentials and electric motors, where preload enhances stiffness or running accuracy, SKF recommends applying preload with springs if an adjustment nut is not available. Springs should also be used under very

Diagram 3

Factors f_1 and f_2 for clearance reduction caused by interference fits

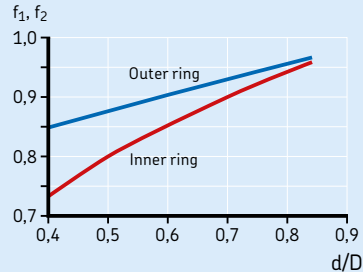

Diagram 4

Temperature differences during start-up

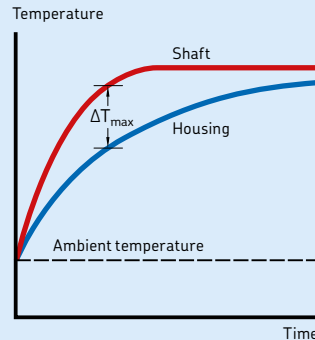

Fig. 34

light or no-load conditions to provide a minimum load on the bearing (→ *Requisite minimum load*, page 86).

Preload can be expressed as a force or as a distance (path), but is typically expressed as a force.

Depending on the adjustment method, preload is also indirectly related to the frictional moment in the bearing.

Empirical preload values can be obtained from proven designs and can be applied to similar designs. For new designs, SKF recommends calculating the preload force and checking its accuracy by testing the application. In general, all influencing factors in operation cannot be fully identified in the design stage and adjustments may be necessary. The accuracy of the calculation depends on how closely the estimated operating temperature and elastic behaviour of the associated components – most importantly the housing – coincide with the actual conditions in operation.

Considerations for preload

Depending on the bearing type, preload may be either radial or axial. Cylindrical roller bearings, for example, can only be preloaded radially because of their design, while thrust ball and cylindrical roller thrust bearings can only be preloaded axially. Single row angular contact ball bearings and tapered roller bearings (→ fig. 34), which are normally subjected to axial preload, are generally mounted together with a second bearing of the same type and size in a back-to-back (load lines diverge) or face-to-face (load lines converge) arrangement. Deep groove ball bearings can also be preloaded axially. If so, the bearings should have a greater radial internal clearance than Normal (such as C3) so that, as with angular contact ball bearings, a contact angle that is greater than zero is obtained.

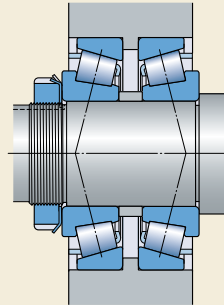

Back-to-back arrangement

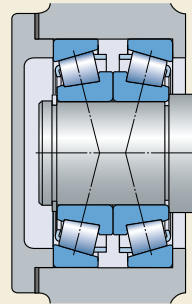

Face-to-face arrangement

F

Design considerations

For both tapered roller and angular contact ball bearings, the distance L between the pressure centres is longer when the bearings are arranged back-to-back (→ **fig. 35**) compared to bearings that are arranged face-to-face (→ **fig. 36**). This means that bearings arranged back-to-back can accommodate relatively large tilting moments even if the distance between the bearing centres is relatively short. The radial loads and bearing deformation resulting from a moment load is smaller for bearings arranged back-to-back than for bearings arranged face-to-face.

If in operation the shaft temperature is higher than the housing temperature, the preload, which was adjusted at ambient temperature during mounting, increases. The in-

crease is greater for bearings arranged face-to-face than for bearings arranged back-to-back. In both cases, however, thermal expansion of the inner ring in the radial direction serves to reduce clearance or increase preload. This tendency is increased by thermal expansion of the rings in the axial direction when the bearings are face-to-face, but is reduced for back-to-back arrangements.

For back-to-back arrangements only: Depending on the distance between the bearings, when the coefficient of thermal expansion is the same for the bearings and associated components, thermal expansion in both the radial and axial directions can cancel each other out so that preload remains unchanged.

Fig. 35

Back-to-back arrangements

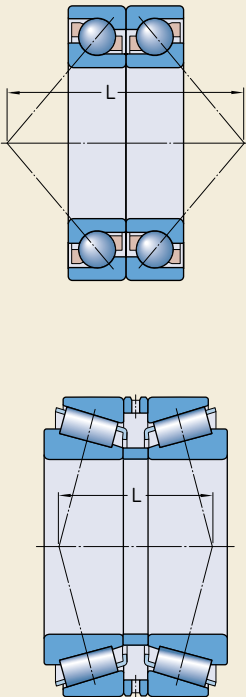
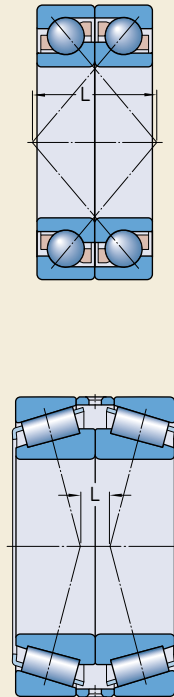

Fig. 36

Face-to-face arrangements



Effects of bearing preload

The primary benefits resulting from preload include but are not limited to:

- enhanced stiffness
- reduced noise levels
- improved shaft guidance
- compensation for wear and settling
- extended bearing service life

Enhanced stiffness

Bearing stiffness is defined as the ratio of the force acting on the bearing to the elastic deformation in the bearing. The elastic deformation caused by a load in preloaded bearings is smaller for a given load range than for bearings that are not preloaded.

Reduced noise levels

As operating clearance in a bearing decreases, guidance of the rolling elements in the unloaded zone improves, which reduces noise levels in operation.

Improved shaft guidance

Preloaded bearings provide more accurate shaft guidance because preload provides a higher degree of stiffness, which limits the ability of the shaft to deflect under load. For example, preloading the ring and pinion bearings in a differential results in increased stiffness, which keeps gear mesh accurate and constant. This minimizes dynamic forces and reduces noise levels, which can extend the service life of the gears.

Compensation for wear and settling

Wear and settling in a bearing arrangement in operation increases the clearance. This clearance can be compensated for with preload.

Extended bearing service life

In certain applications, an optimum preloaded bearing system (→ *Selecting the correct preload*, page 225) can enhance operational reliability, provide more favourable load distribution in the bearings and extend bearing service life.

Design considerations

Preload in bearing systems with angular contact ball or tapered roller bearings

When determining preload, the preload force required to provide an optimum combination of stiffness, bearing service life and operational reliability should be calculated first. Then calculate the preload force to be used when adjusting the bearings during mounting. When mounting, the bearings should be at ambient temperature and should not be subjected to any other load.

The appropriate preload at normal operating temperature depends on the bearing load. An angular contact ball bearing or a tapered roller bearing can accommodate radial and axial loads simultaneously. Under radial load, these bearings produce a resultant axial load which must be accommodated by a second bearing facing the opposite direction. Purely radial displacement of one bearing ring relative to the other means that half of the rolling elements are under load. The resultant axial load produced in the bearing can be determined by:

- for single row angular contact ball bearings
 $F_a = R F_r$
- for single row tapered roller bearings
 $F_a = 0,5 F_r / Y$

where

F_a = axial bearing load (→ fig. 37)

F_r = radial bearing load (→ fig. 37)

R = variable for inside contact conditions

(→ *Calculating the axial load for bearings mounted singly or paired in tandem*, page 495)

Y = calculation factor (→ **product tables**)

When a single bearing is subjected to a radial load F_r , an axial load F_a (external) of the same magnitude as the resultant load must be applied to the bearing if the basic load rating is to be fully exploited. If the applied external load is lighter, there are fewer rolling elements supporting the load and the load carrying capacity of the bearing is correspondingly reduced.

In a bearing system consisting of two single row angular contact ball bearings or two tapered roller bearings arranged back-to-back or face-to-face, each bearing arrangement must accommodate the axial load in one direction. When these bearing systems are adjusted to near-zero clearance, the radial load is shared equally between the two bearings and half the rolling elements in each bearing are loaded.

In other cases, where there is an external axial load, it may be necessary to preload the bearings to compensate for the clearance that can occur when the axially loaded bearing deforms elastically. Preload also distributes the loads more favourably in an axially unloaded bearing.

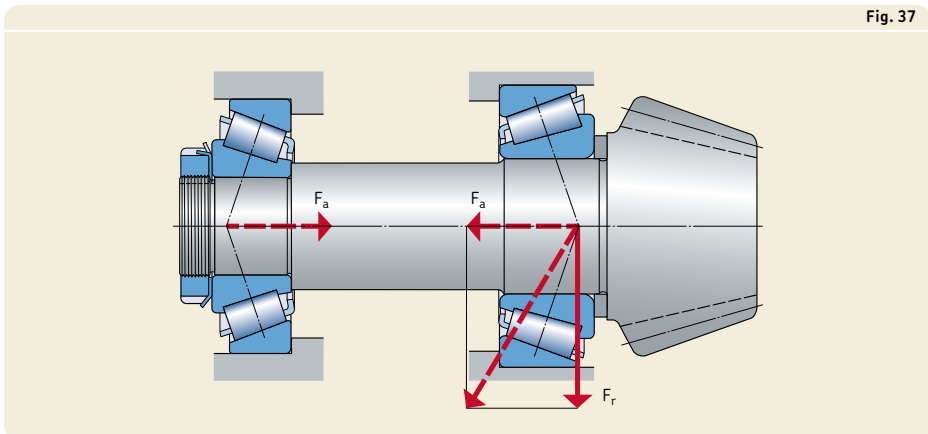

Fig. 37

Preload also increases the stiffness of a bearing system. However, keep in mind that stiffness is also influenced by the elasticity of the shaft and housing, the shaft and housing fits, as well as the elastic deformation of all other components adjacent to the bearings, including the abutments. Each of these has a considerable impact on the resilience of the total bearing system. The axial and radial resilienties of a bearing depend on its internal design, contact conditions (point or line contact), the number and diameter of rolling elements and the contact angle. The greater the contact angle, the higher the degree of stiffness in the axial direction.

If, as a first approximation, a linear dependence of the resilience on the load is assumed, such as a constant spring ratio, a comparison shows that the axial displacement in a bearing system under preload is smaller than for a bearing system without preload for the same external axial force K_a (→ **diagram 5**). A pinion arrangement design (→ **figs. 39 and 40, page 222**) typically consists of two different size tapered roller bearings, A and B, with different spring constants c_A and c_B . Both are subjected to a preload force F_0 . If an axial force K_a acts on bearing A, bearing B becomes unloaded, and the additional load acting on bear-

ing A results in an axial displacement δ_a that is smaller than it would be if the bearings had not been preloaded. However, B is relieved of the axial preload force and the axial displacement under additional load is the same as it is for a bearing system without preload, that means determined solely by the spring constant c_A , if the external axial force exceeds the value

$$K_a = F_0 \left(1 + \frac{c_A}{c_B} \right)$$

To prevent bearing B from becoming unloaded when bearing A is subjected to an axial force K_a , the following preload force is required

$$F_0 = K_a \left(\frac{c_B}{c_A + c_B} \right)$$

Diagram 5

Axial displacement in bearing systems with and without preload

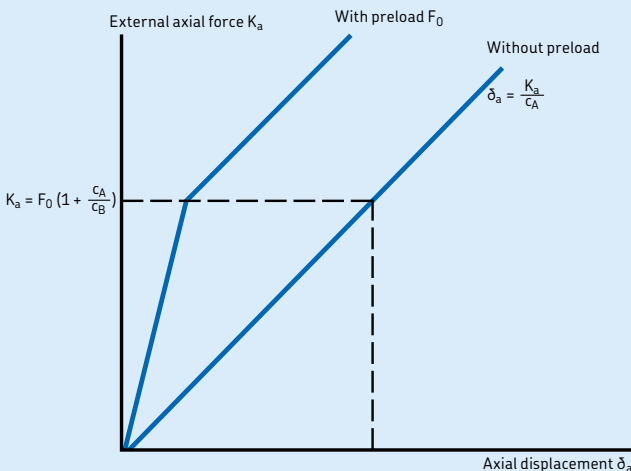

F

Design considerations

Loads and elastic displacements in a preloaded bearing system, as well as the effects of a change in preload, are easily understood from a preload force / axial displacement diagram (→ **diagram 6**). This consists of the spring curves of the components that are adjusted against each other to apply preload and enables the following:

- the relationship of the preload force and axial displacement within the preloaded bearing system
- the relationship between an externally applied axial force K_a and the bearing load for a preloaded bearing system, as well as the elastic deformation produced by an external load

In **diagram 6**, all the components subjected to external loads in operation are represented by the curves that increase from left to right, and all the unloaded components by the curves that increase from right to left. Curves 1, 2 and 3 are for different preload forces (F_{01} , $F_{02} < F_{01}$ and $F_{03} = 0$). The broken lines represent individual bearings, while the solid lines represent the total bearing system (bearing(s) and associated components) for different preload forces.

From **diagram 6**, it is also possible to explain the relationship between components, for example in a pinion arrangement design (→ **fig. 39, page 222**), where bearing A is located adjacent to a gear and is adjusted against bearing B to provide preload. The external axial force K_a (axial component of tooth forces) is superimposed on the preload force F_{01} (curve 1) in such a way that bearing A is subjected to additional load while bearing B is unloaded. The load on bearing A is designated F_{aA} and on bearing B it is designated F_{aB} . Under the influence of the axial force K_a , the pinion shaft is axially displaced by the amount δ_{a1} .

The smaller preload force F_{02} (curve 2) has been chosen so that bearing B is just unloaded by the axial force K_a , that means $F_{aB} = 0$ and $F_{aA} = K_a$. The pinion shaft is displaced in this case by the amount $\delta_{a2} > \delta_{a1}$.

When the arrangement is not preloaded (curve 3), the axial displacement of the pinion shaft is greatest ($\delta_{a3} > \delta_{a2}$).

Diagram 6

Influence of preload and axial load on axial displacement in bearing systems

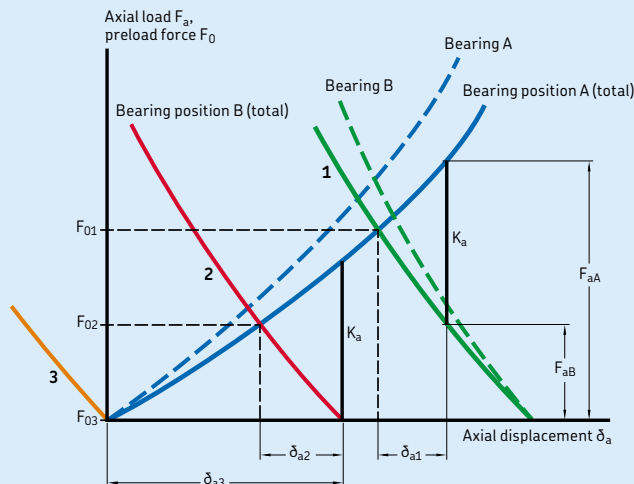

Adjustment procedures

Adjustment means setting the bearing internal clearance (→ *Mounting*, page 275) or preload in a bearing system.

The radial preload typically used for cylindrical roller bearings, double row angular contact ball bearings and sometimes for deep groove ball bearings, for example, is achieved by an interference fit on one or both bearing rings. The degree of interference should reduce residual clearance to zero, which is further reduced to a negative clearance (preload) when the bearing is in operation.

Bearings with a tapered bore are particularly suitable for radial preloading since, by driving the bearing up onto its tapered seat, the preload can be applied to within narrow limits.

Axial preload in a bearing system with single row angular contact ball bearings, tapered roller bearings and deep groove ball bearings is produced by displacing one bearing ring axially, relative to the other, by an amount corresponding to the desired preload force. There are basically two principal methods to adjust preload: individual adjustment and collective adjustment.

Individual adjustment

With individual adjustment, each bearing system is adjusted separately using nuts, shims, spacer sleeves, crush sleeves etc. Measuring and inspection procedures provide that the established nominal preload is obtained with the least possible deviation. There are different methods to obtain the required preload:

- axial displacement method
- frictional moment method
- direct force method

The method used depends on, among other things, the application design and the number of bearings to be mounted. Individual adjustment can accommodate enough tolerance stack-up so that if individual components are produced to Normal tolerances, the desired preload can be achieved with a relatively high degree of accuracy.

Fig. 38

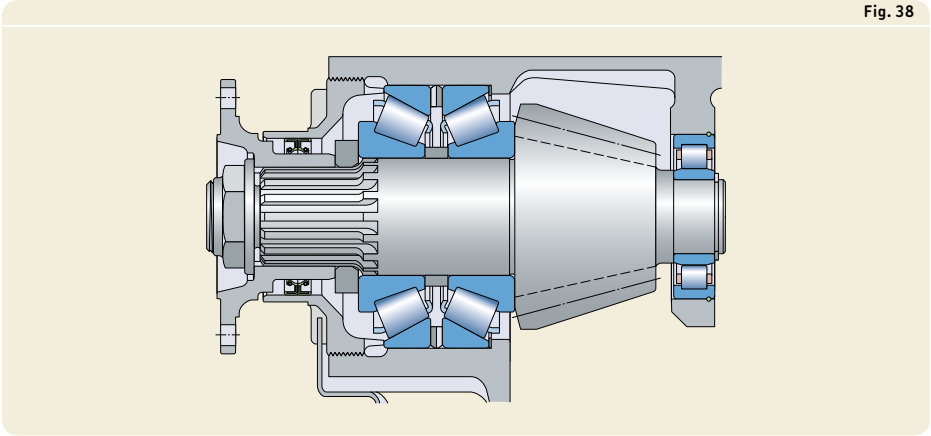

Fig. 39

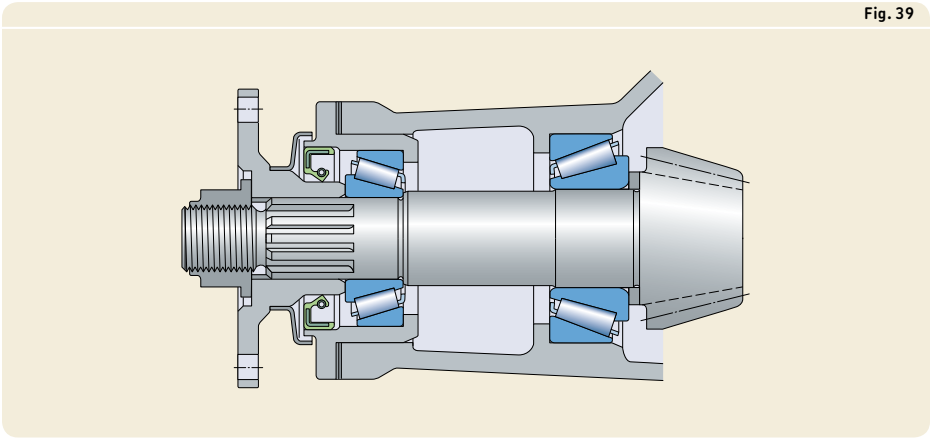
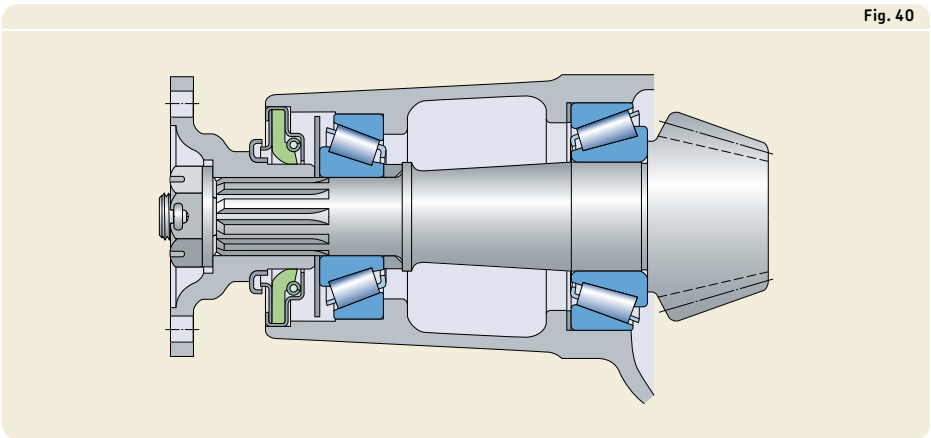

Fig. 40



Axial displacement method

The axial displacement method is based on the relationship between the preload force and the elastic deformations within the bearing system. The requisite preload can be determined from a preload force / axial displacement diagram (→ **diagram 7**).

This method of adjustment is frequently used when the components of a bearing system are pre-assembled. The required preload, which is expressed as a linear value, requires measuring total axial displacement (end play) of the shaft relative to a fixed surface. This is typically done with a dial indicator.

Shims, intermediate rings or spacers can then be used to adjust axial displacement to the correct value. The preload is achieved, for example, for pinion arrangement designs by:

- fitting intermediate rings between the inner and outer rings of the two bearings (→ **fig. 38**)
- inserting shims between the housing shoulder and the bearing outer ring or between the cartridge and the housing (→ **fig. 39**), where the cartridge in this case is the flanged angled insert

- fitting a spacer between a shaft shoulder and one of the bearing inner rings (→ **fig. 40**) or between the inner rings of both bearings

The width of the shims, intermediate rings or spacers is determined by:

- the distance between the shaft and housing shoulders
- the total width of both bearings
- the axial displacement corresponding to the desired preload force
- a correction factor for the axial displacement to account for thermal expansion in operation
- the manufacturing tolerances of all related components, established by measuring the actual dimensions before mounting
- a correction factor to account for a certain loss of preload as a result of settling and wear

Diagram 7

Relationship between the preload force and the axial displacements within a bearing system, for example in a pinion arrangement design

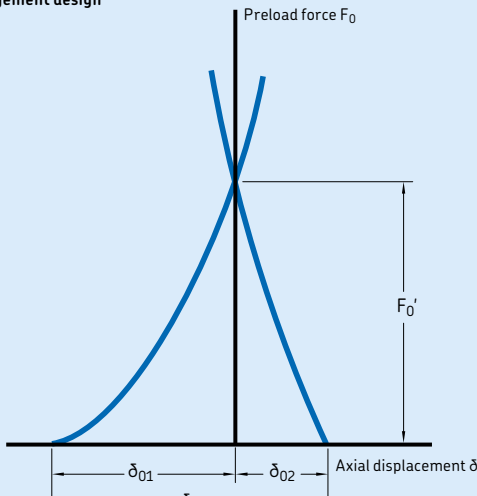

- F_0' Preload force on the pinion shaft (bearing system)
- δ_{01} Axial displacement for the pinion head bearing and surrounding components
- δ_{02} Axial displacement for the bearing at the flange side and surrounding components
- δ_0 Total axial displacement for pinion bearing system



Design considerations

Frictional moment method

This method is common in series production because it is fast and can be automated. Since there is a relationship between bearing preload and the frictional moment in the bearings, it is possible to stop adjustment when a frictional moment corresponding to the desired preload has been reached. This can be done if the frictional moment is continuously monitored while setting preload. However, the frictional moment can vary from bearing to bearing, and it also depends on the preservative, the lubricant and the sealing method.

Direct force method

As the purpose of bearing adjustment is to obtain a specific preload, it would seem sensible to use a method either to produce or to measure the force directly. However, in practice, the indirect methods of adjustment by axial displacement or frictional moment are preferred as they are simple and can be achieved easily and more cost-effectively.

Collective adjustment

This method can also be referred to as "random statistical adjustment". Using this method, the bearings, shaft, housing, and any other components are manufactured to Normal tolerances. The components, which are considered fully interchangeable, are assembled randomly. Where tapered roller bearings are concerned, this interchangeability also extends to the inner ring assemblies and outer rings. To avoid high machining costs and the use of

precision bearings, it is assumed that given the limiting values of the tolerances, it is statistically improbable that tolerance stack-up occurs. If, however, accurate preload is to be obtained with as little scatter as possible, manufacturing tolerances must be narrowed. The advantage of collective adjustment is that no inspection is required and no extra equipment is needed when mounting the bearings.

Preloading with springs

By preloading bearings in small electric motors (up to frame size of 132) or similar applications, it is possible to reduce bearing noise levels. The bearing system in this case comprises a single row deep groove ball bearing at each end of the shaft. The simplest method of applying preload is to use a spring or spring package (→ fig. 41). The spring acts on the outer ring of one of the two bearings. This outer ring must be able to be axially displaced. The preload force remains practically constant, even when there is axial displacement of the bearing as a result of thermal elongation. The requisite preload force can be estimated using

$$F = k d$$

where

F = preload force [kN]

d = bearing bore diameter [mm]

k = a factor, → following

Depending on the design of the electric motor, values of between 0,005 and 0,01 are used for

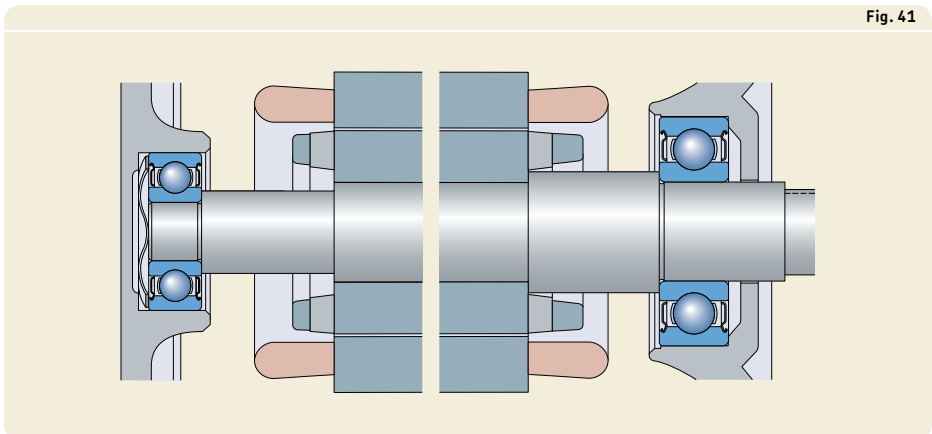

the factor k . If preload is used primarily to protect the bearing from the damage caused by external vibrations when stationary, then greater preload is required and $k = 0,02$ should be used.

Spring loading is also a common method of applying preload to angular contact ball bearings in high-speed grinding spindles. The method is not suitable, however, for bearing applications where a high degree of stiffness is required, where the direction of load changes, or where undefined shock loads can occur.

Selecting the correct preload

When selecting the preload for a bearing system, the degree of stiffness increases marginally once preload exceeds a given optimum value. When exceeding the optimum value, friction and the resulting increase in heat can substantially reduce bearing service life and negate any benefits (→ **diagram 2, page 212**). Excessive preload involves a risk that the operational reliability of a bearing system is compromised. Because of the complexity normally required to calculate an appropriate preload, SKF recommends contacting the SKF application engineering service.

When adjusting preload in a bearing system, it is also important that the established preload value, determined either by calculation or by experience, is attained with the least possible scatter. To reduce scatter when mounting tapered roller bearings, for example, the shaft should be turned several times, if possible, so that the rollers are not skewed and the roller ends are in contact with the guide flange of the inner ring. Turning the shaft also enables the rollers to make full contact with the outer ring and avoids damage to the raceways. When the rollers are not fully settled into position, a much smaller preload than the requisite value results.

Bearings for preloaded bearing systems

For certain applications, SKF supplies single bearings or matched bearings, which are specifically made to enable simple and reliable adjustment, or which are matched during manufacture so that after mounting, a predetermined preload is obtained. These include:

- tapered roller bearings to CL7C specifications for higher running accuracy, such as automotive differentials (→ *Tapered roller bearings, page 797*)
- universally matchable single row angular contact ball bearings (→ *Angular contact ball bearings, page 475*)
- matched single row tapered roller bearings (→ *Tapered roller bearings, page 797*)
- matched single row deep groove ball bearings (→ *Deep groove ball bearings, page 295*)

Sealing solutions

All bearing systems include a shaft, bearings, housing(s), lubricant, associated components, and seals. Seals are vital to the cleanliness of the lubricant and the service life of the bearings.

Where seals for rolling bearings are concerned, a distinction is made between seals that are integrated in the bearing and those that are positioned outside the bearing. Bearings that are capped with seals or shields are generally used in bearing systems where an effective external sealing arrangement is not practical due to space or cost reasons, or where these seals or shields are adequate for the operating conditions.

Seal types

The purpose of a seal is to retain lubricant and prevent any contaminants from entering into a controlled environment. To be effective, a seal should exhibit the following main characteristics:

- flexible enough to compensate for any surface irregularities
- strong enough to withstand operating pressures
- able to accommodate a wide range of operating temperatures
- resistant to common chemicals
- operate with lowest possible friction, frictional heat and wear

There are several basic seal types:

- static seals
- dynamic seals
- non-contact seals
- bellows and membranes

Seals that make contact with stationary surfaces are called static seals. Their effectiveness depends on the radial or axial deformation of their cross section when installed. Gaskets (→ fig. 42) and O-rings (→ fig. 43) are typical examples of static seals.

Seals in contact with sliding surfaces are called dynamic seals and are used to seal passages between machine components that move relative to each other either linearly or

Fig. 42

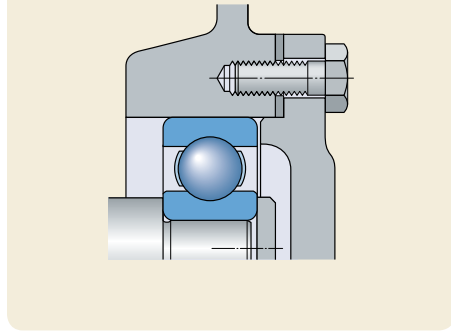

circumferentially. Dynamic seals are designed to retain lubricant, exclude contaminants, separate different media and withstand differential pressures. There are various types of dynamic seals, including packing or piston rings, which are used for linear or oscillating movements. However, the most common seal is the radial shaft seal (→ fig. 44), which makes contact with both a stationary and rotating component.

Non-contact radial shaft seals form a narrow gap between the stationary seal lip and rotating component. The gap can be arranged axially, radially or in combination. Non-contact seals, which range from simple gap-type seals to multi-stage labyrinths (→ fig. 45), generate almost no friction and, therefore, do not wear.

Bellows and membranes are used to seal components that have limited movement relative to each other.

Because of their importance for bearing applications, the following information deals almost exclusively with contact and non-contact radial shaft seals, their various designs and executions.

Fig. 43

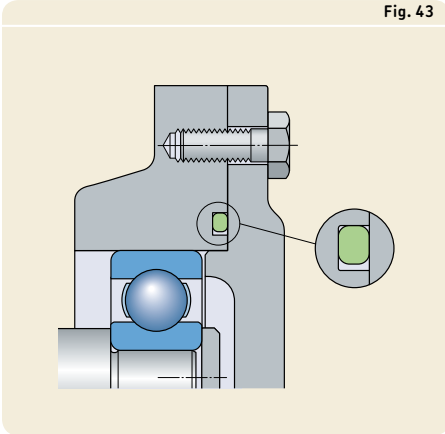

Fig. 44

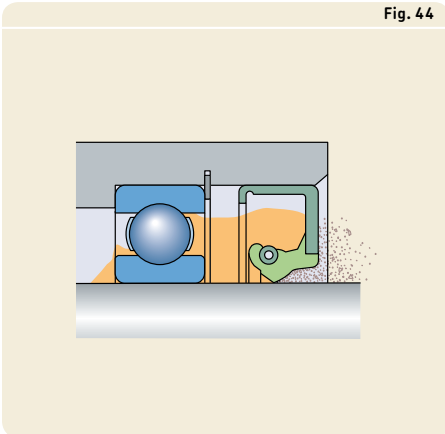
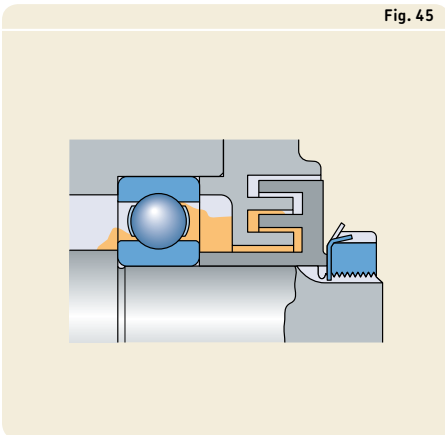

Fig. 45



Selecting seal type

Seals for bearing arrangements should provide maximum protection with a minimum amount of friction and wear, even under the most arduous operating conditions. Because bearing performance and service life are so closely tied to the effectiveness and cleanliness of the lubricant, the seal is a key component in a bearing system. For more information on the influence of contaminants on bearing performance, refer to *Selecting bearing size* (→ page 61).

Many factors have to be considered when selecting the most suitable seal for a particular bearing system. They include:

- the lubricant type: oil, grease or other
- the circumferential speed of the seal counterface
- the shaft arrangement: horizontal or vertical
- possible shaft misalignment or deflection
- run-out and concentricity
- available space
- seal friction and the resulting temperature increase
- environmental influences
- cost

Where full application details are available, refer to:

- *Power transmission seals* (→ skf.com/seals)
- the product information available online at skf.com/seals

SKF is one of the largest seal manufacturers in the world and can assist in the selection process if little or no experience is available for a given application. For additional information, contact the SKF application engineering service.

F

Design considerations

Non-contact seals

The effectiveness of a non-contact seal depends, in principle, on the sealing action of the narrow gap between the shaft and housing. The gap may be arranged radially, axially or in combination (→ **fig. 46**). These seals can be as simple as a gap-type radial shaft seal or more complex, like a labyrinth seal. In either case, because there is no contact, these seals generate almost no friction and do not wear. They are not easily damaged by solid contaminants and are particularly well suited for high speeds and high temperatures.

Contact seals

The effectiveness of a contact seal is determined by the amount of pressure available to keep the seal lip in contact with the seal counterface on the shaft. This pressure (→ **fig. 47**) can be produced either by:

- the resilience of the seal, resulting from the elastic properties of the seal material (**a**)
- the designed interference between the seal and its counterface (**b**)
- a tangential force exerted by a garter spring incorporated in the seal (**c**)

Contact seals are generally very reliable.

Their effectiveness, however, depends on the surface finish of the counterface, the condition of the seal lip and the presence of lubricant between the seal lip and counterface. Friction between the seal lip and counterface can generate a significant amount of heat. As a result, these seals have circumferential speed limits. They are also susceptible to mechanical damage as a result of improper mounting, or by solid contaminants. To protect the seal from the damage caused by solid contaminants, a non-contact seal is typically placed in front of a contact seal.

Fig. 46

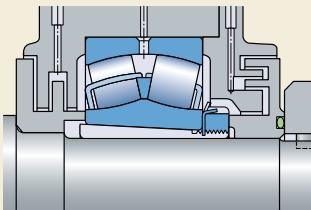
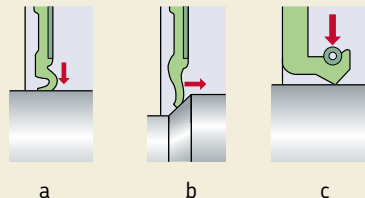

Fig. 47



Integral bearing seals

SKF supplies several bearing types capped with a seal or shield on one or both sides. These provide an economic and space-saving solution to many sealing problems. Bearings capped on both sides are supplied already greased and are generally considered maintenance-free. Actual seal designs are described in detail in the relevant product chapter.

Bearings with shields

Bearings fitted with shields (→ **fig. 48**) are used in applications where the operating conditions are dry and relatively clean. Shields are also used in applications where reduced friction is important due to speed or operating temperature considerations.

Shields form either a narrow gap toward the inner ring shoulder (**a**) or an effective labyrinth with a recess in the inner ring shoulder (**b**).

Bearings with contact seals

Bearings with contact seals, referred to simply as seals, are preferred for arrangements where contamination is moderate and the presence of water or moisture cannot be ruled out, or where maximum bearing service life and minimum maintenance are required.

SKF has developed a variety of seal designs (→ **fig. 49**). Depending on the bearing type or size, the seal makes contact with:

- the inner ring or inner ring shoulder (**a, e**)
- the recess in the inner ring shoulder (**b, c**)
- the lead-in chamfer on the sides of the inner ring raceway (**d**)
- the outer ring (**f**)

Fig. 48

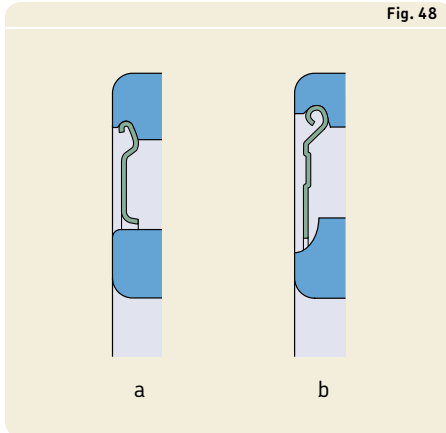
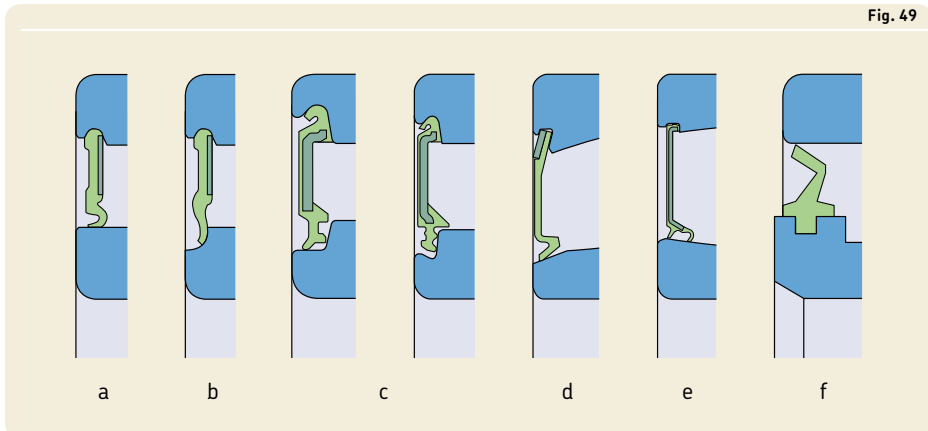

Fig. 49



F

Design considerations

For deep groove ball bearings, SKF has developed additional seal types (→ **fig. 50**):

- The SKF non-contact seal (**a**) forms an extremely narrow gap with the inner ring shoulder.
- The SKF low-friction seal (**b, c**) makes almost no contact with the inner ring, but provides very good low-friction operation.
- The SKF WAVE seal (**d**), a spring-loaded radial shaft seal designed for oil lubricated applications, is incorporated on one side of the bearing (→ *ICOS oil sealed bearing units*, **page 304**)

SKF bearing seals are generally made of an elastomeric compound that is vulcanized to a sheet steel reinforcement ring. Depending on the series, size and the application requirements, typical seal materials are:

- acrylonitrile-butadiene rubber (NBR)
- hydrogenated acrylonitrile-butadiene rubber (HNBR)
- fluoro rubber (FKM)
- polyurethane (PUR)

The selection of the appropriate seal material depends on the expected operating temperature and the lubricant that is applied. For permissible operating temperatures, refer to *Seal materials* (→ **page 155**).

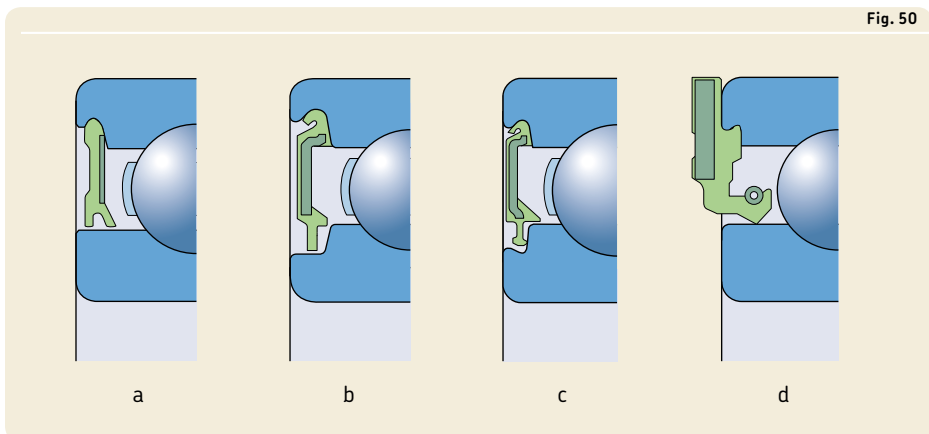

External seals

For bearing arrangements where the effectiveness of the seal under specific operating conditions is more important than space considerations or cost, there are several possible seal types to choose from.

For seals that are not supplied by SKF, the information provided in the following section is to be used as a guideline only. SKF does not accept liability for the performance of any products not supplied by SKF. Make sure to understand the seal's performance criteria before incorporating that seal into an application.

Non-contact seals

The simplest seal used outside a bearing is the gap-type seal, which creates a small gap between the shaft and housing (→ **fig. 51**). This type of seal is adequate for grease lubricated applications that operate in dry, dust-free environments. To enhance the effectiveness of this seal, one or more concentric grooves can be machined in the housing bore at the shaft end (→ **fig. 52**). The grease emerging through the gap fills the grooves and helps to prevent the entry of contaminants.

With oil lubrication and horizontal shafts, helical grooves – right-hand or left-hand depending on the direction of shaft rotation – can be machined into the shaft or housing bore (→ **fig. 53**). These grooves are designed to return emerging oil to the bearing position. Therefore, it is essential that the shaft rotates in one direction only.

Fig. 51

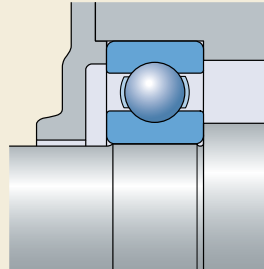

Fig. 52

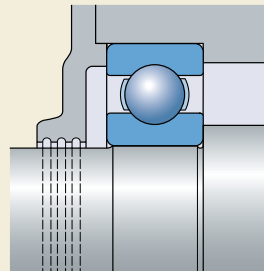
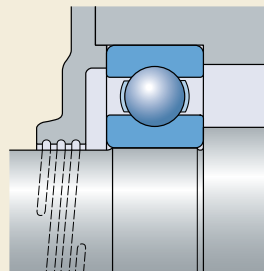

Fig. 53



F

Design considerations

Single or multi-stage labyrinth seals, typically used with grease lubrication, are considerably more effective than simple gap-type seals, but are also more expensive. Their effectiveness can be further improved by periodically applying a water-insoluble grease, such as a grease with a lithium-calcium thickener, via a duct to the labyrinth passages. The passages of the labyrinth seal can be arranged axially (→ **fig. 54**) or radially (→ **fig. 55**), depending on the housing type (split or non-split), mounting procedures, available space etc. The width of the axial passages of the labyrinth (→ **fig. 54**) remain unchanged when axial displacement of the shaft occurs in operation and can therefore be very narrow. If angular misalignment of the shaft relative to the housing can occur, labyrinths with inclined passages can be used (→ **fig. 56**).

Effective and inexpensive labyrinth seals can be made using commercially available products, such as SKF sealing washers (→ **fig. 57**). Sealing effectiveness increases with the number of washer sets and can be further improved by incorporating flocked washers. For additional information on these sealing washers, refer to *Power transmission seals* (→ skf.com/seals).

Rotating discs (→ **fig. 58**) are often fitted to the shaft to improve the sealing action of shields. Flingers, grooves or discs are used for the same purpose with oil lubrication. The oil from the flinger is collected in a channel in the housing and returned to the housing sump through suitable ducts (→ **fig. 59**).

Fig. 54

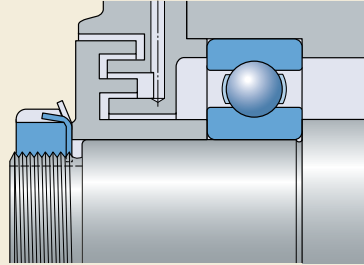

Fig. 55

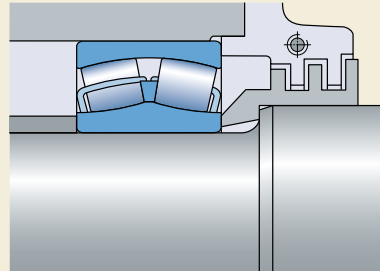

Fig. 56

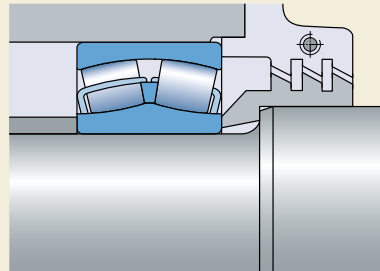

Fig. 57

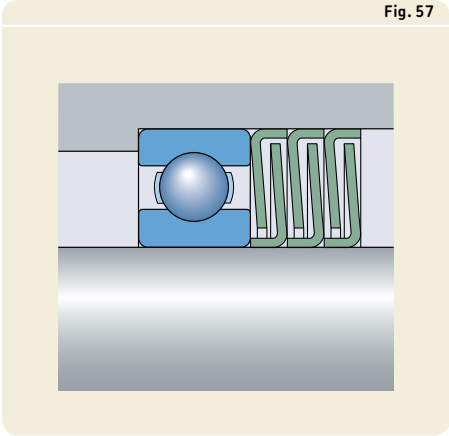

Fig. 58

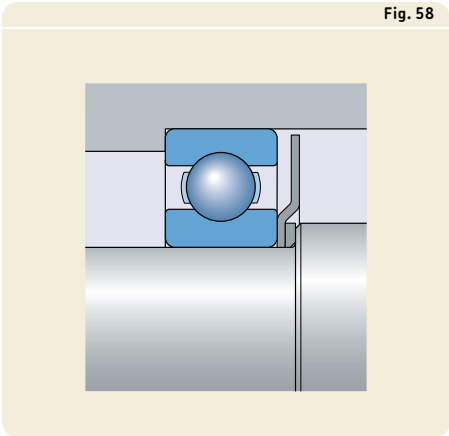
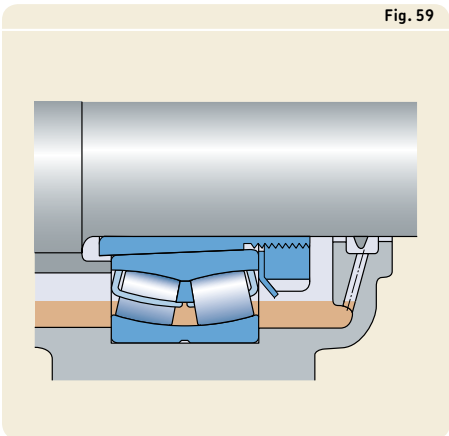

Fig. 59



Design considerations

Contact seals

There are four common types of contact seals:

- radial shaft seals (→ **figs. 60** and **61**)
- V-ring seals (→ **fig. 62**)
- axial clamp seals (→ **fig. 63**)
- mechanical seals (→ **fig. 64, page 236**)

The seal type selected for a particular application typically depends on its primary purpose (retain lubricant or exclude contaminants), type of lubricant (oil, grease or other) and operating conditions (speed, temperature, level of contamination).

Radial shaft seals

Radial shaft seals (→ **figs. 60** and **61**) are contact seals that are used mainly in oil lubricated applications. These ready-to-mount components typically consist of a metal reinforcement or casing, a synthetic rubber body, a seal lip and a garter spring. The seal lip is pressed against the shaft by the garter spring. Depending on the seal material and medium to be retained and/or excluded, radial shaft seals can be used at temperatures between -60 and $+190$ °C (-75 to 375 °F).

The seal counterface, that part of the shaft where the seal lip makes contact, is of vital importance to sealing effectiveness. The surface hardness of the counterface should be at least 55 HRC at a depth of at least 0,3 mm. The surface roughness should be in accordance with ISO 4288 and within the guidelines of $R_a = 0,2$ to $0,8$ μm . In applications where speeds are slow, lubrication is good, and contamination levels are minimal, a lower hardness can be acceptable. To avoid the pumping effect induced by helical grinding marks, SKF recommends plunge grinding the counterface.

If the primary purpose of the radial shaft seal is lubricant retention, the seal should be mounted with the lip facing inward (→ **fig. 60**). If the primary purpose is to exclude contaminants, the lip should face outward, away from the bearing (→ **fig. 61**).

Fig. 60

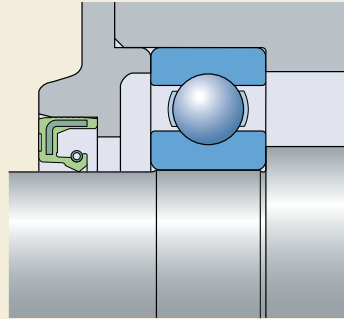
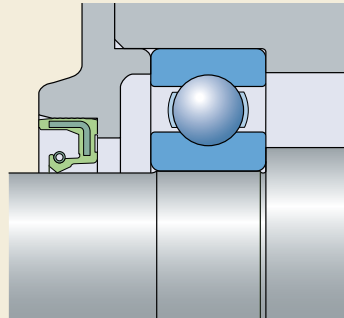

Fig. 61



V-ring seals

V-ring seals (→ **fig. 62**) can be used with either oil or grease lubrication. The elastic rubber body of the seal grips the shaft and rotates with it, while the seal lip exerts a light axial pressure on a stationary component, such as a housing. Depending on the material, V-rings can be used at operating temperatures between -40 and $+150$ °C (-40 to 300 °F). They are simple to install and permit relatively large angular misalignments of the shaft at slow speeds.

A surface roughness of $R_a = 2$ to 3 μm is sufficient for the counterface. At circumferential speeds above 8 m/s, the body of the seal must be located axially on the shaft. At speeds above 12 m/s, the body must be prevented from lifting from the shaft. A sheet metal support ring can be used to do this. When circumferential speeds exceed 15 m/s, the seal lip lifts away from the counterface and the V-ring becomes a gap-type seal.

The good sealing ability of a V-ring seal can be attributed to the body of the seal, which acts as a flinger, repelling dirt and fluids. As a result, these seals are generally arranged outside the housing in grease lubricated applications and inside the housing, with the lip pointing away from the bearing, in oil lubricated applications. Used as a secondary seal, V-rings protect the primary seal from excessive contaminants and moisture.

Axial clamp seals

Axial clamp seals (→ **fig. 63**) are used as secondary seals for large diameter shafts in applications where protection is required for the primary seal. They are clamped in position on a non-rotating component and seal axially against a rotating counterface. For this type of seal, it is sufficient if the counterface is fine turned and has a surface roughness $R_a = 2,5$ μm .

Fig. 62

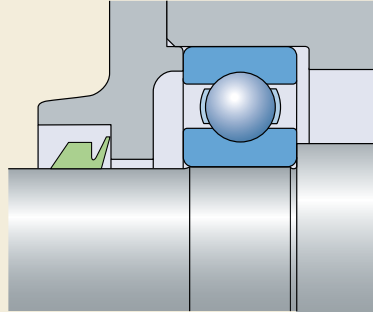
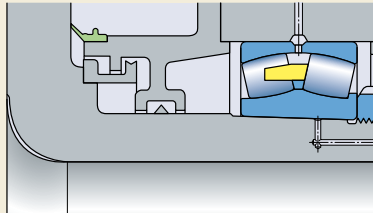

Fig. 63



F

Design considerations

Mechanical seals

Mechanical seals (→ **fig. 64**) are used to seal grease or oil lubricated applications where speeds are relatively slow and operating conditions difficult and arduous. They consist of two sliding steel rings with finely finished sealing surfaces and two plastic cup springs (Belleville washers), which position the sliding rings in the housing bore and provide the necessary preload force to the sealing surfaces. There are no special demands on the mating surfaces in the housing bore.

Other seals

Felt seals (→ **fig. 65**) are generally used with grease lubrication. They are simple, cost-effective and can be used at circumferential speeds of up to 4 m/s and at operating temperatures up to 100 °C (205 °F). The counterface should be ground to a surface roughness $R_a \leq 3,2 \mu\text{m}$. The effectiveness of a felt seal can be improved substantially by mounting a simple labyrinth seal as a secondary seal. Before being inserted in the housing groove, felt seals should be soaked in oil at about 80 °C (175 °F) prior to mounting.

Metal seals (→ **fig. 66**) are simple, cost-effective and space-saving seals for grease lubricated bearings, particularly deep groove ball bearings. The seals are clamped against either the inner or outer ring and exert a resilient axial pressure against the other ring. After a certain running-in period, these seals become non-contact seals by forming a very narrow gap with the rotating ring.

For additional information about seals supplied by SKF, refer to *Power transmission seals* (→ skf.com/seals).

Fig. 64

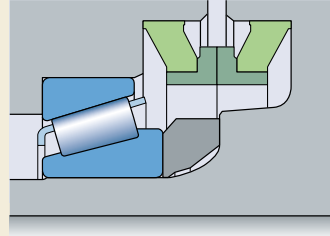

Fig. 65

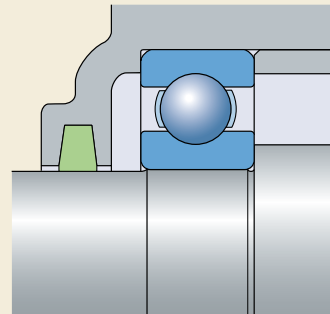
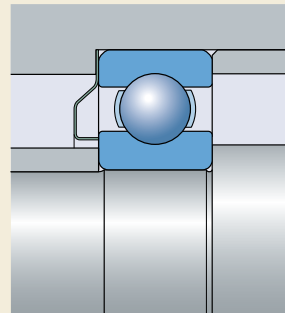

Fig. 66





Temperature



Lubrication

Basics of lubrication	240	Relubrication procedures	258
Viscosity ratio κ	241	Replenishment	258
Grease lubrication	242	Renewing the grease fill.	260
Lubricating greases	244	Continuous relubrication	261
Temperature range – the SKF traffic light concept	244	Oil lubrication	262
Temperature zones	246	Oil lubrication methods	262
Consistency.	246	Oil bath	262
Base oil viscosity.	246	Oil pick-up ring	263
Protection against corrosion	248	Circulating oil	263
Load carrying ability.	248	Oil jet	264
Extreme pressure additives.	248	Oil-air	264
Anti-wear additives	248	Oil mist	264
Miscibility	248	Lubricating oils	265
SKF greases	249	Selecting lubricating oils	266
Relubrication	252	Oil change	267
Relubrication intervals.	252		
Adjustments of relubrication intervals due to operating conditions and bearing types	252		
Operating temperature	252		
Vertical shafts.	253		
Vibration	253		
Outer ring rotation	253		
Contamination	253		
Very slow speeds	254		
High speeds	254		
Heavy and very heavy bearing loads	254		
Very light bearing loads	254		
Misalignment	254		
Large bearings	254		
Cylindrical roller bearings	254		
Observations	255		



Basics of lubrication

Rolling bearings need to be adequately lubricated to operate reliably and to prevent direct metal-to-metal contact between the rolling elements, raceways, cages and other components. The lubricant also inhibits wear and protects the bearing surfaces against corrosion. The choice of a suitable lubricant and lubrication method is important, as is proper maintenance.

A wide assortment of greases, oils and alternative lubricants like graphite-based compounds are available to lubricate rolling bearings. Selecting a lubricant depends primarily on the operating conditions such as the temperature range and speeds. However, other factors like vibration and loads can also influence lubricant selection.

Generally, the most favourable operating temperatures can be obtained when the minimum amount of lubricant needed to reliably lubricate a bearing is provided. However, when the lubricant has additional functions, such as sealing or removing heat, additional amounts of lubricant may be required.

The lubricant in a bearing arrangement gradually loses its lubricating properties as a result of mechanical working, ageing and the build-up of contaminants. It is therefore necessary for grease to be replenished or renewed and for oil to be filtered and changed at regular intervals.

The information and recommendations in this section relate to bearings without integral seals or shields. SKF bearings and bearing units with an integral seal and/or shield on both sides are factory-greased. Information about the standard greases used by SKF is provided in the relevant product chapters, together with a brief description of the performance data.

Under normal operating conditions, the service life of the grease in sealed bearings exceeds the service life of the bearing so that, with some exceptions, no provision is made for the relubrication of these bearings.

For purposes of this discussion, normal operating conditions can be defined as:

- constant loads in magnitude and direction
- loads equal to or larger than the recommended minimum load and at least:
 - 0,01 C for ball bearings
 - 0,02 C for roller bearings
- constant speed, but not higher than the permissible speed
- appropriate operating clearance
- for grease lubrication:
 - only steady state conditions (after several hours of operation)
 - lithium soap grease with mineral oil
 - bearing free volume filled approximately 30%
 - minimum ambient temperature 20 °C (70 °F)
- for oil lubrication:
 - oil bath, oil-air or oil jet
 - viscosity range from 2 to 500 mm²/s

Ring centred cages

Bearings with ring centred cages are primarily designed for oil lubrication. Grease lubrication can be used for moderate speeds. Information about the cage designs and the limits are provided in the relevant product chapters, if applicable.

Lubricant specifications

Differences in the lubricating properties of seemingly identical lubricants – particularly grease – produced at different locations, or even different production batches from the same location, can exist. Therefore, SKF cannot accept liability for any lubricant or its performance. The user is therefore advised to specify lubricant properties in detail to obtain the most suitable lubricant for the application.

Viscosity ratio κ

The importance of the oil viscosity to form a hydrodynamic oil film that separates the bearing contact surfaces is already mentioned under *Lubrication conditions – the viscosity ratio κ* (→ **page 71**). That information applies equally to the base oil viscosity of lubricating greases and oils.

The condition of the lubricant is described by the viscosity ratio κ as the ratio of the actual viscosity ν to the rated viscosity ν_1 for adequate lubrication, when the lubricant is at normal operating temperature.

$$\kappa = \frac{\nu}{\nu_1}$$

where

κ = viscosity ratio

ν = actual operating viscosity of the lubricant
[mm²/s]

ν_1 = rated viscosity of the lubricant depending on the bearing mean diameter and rotational speed [mm²/s]

To separate the bearing contact surfaces, a minimum viscosity ratio $\kappa = 1$ is required. Full-film conditions exist when $\kappa \geq 4$, i.e. a sufficient hydrodynamic film is formed for adequate lubrication. However, SKF recommends limiting κ to 4, otherwise the frictional heat decreases the operating viscosity.

In applications where $\kappa < 1$, a sufficient hydrodynamic film cannot be formed and metal-to-metal contact may occur. The use of lubricants containing extreme pressure or anti-wear additives (→ *Load carrying ability*, **page 248**) might extend bearing service life.

For oil lubricated applications where $\kappa < 0,4$, an oil with EP additives must be used.

In applications where $\kappa < 1$, hybrid bearings (→ *Hybrid bearings*, **page 1219**) can be considered. Even under inadequate lubrication conditions, there is reduced risk of smearing between silicon nitride and steel surfaces.

Grease lubrication

The majority of rolling bearings are grease lubricated. Compared to oil, the advantage is that grease is more easily retained in the bearing arrangement, particularly where shafts are inclined or vertical. Grease also contributes to sealing the arrangement against solid and liquid contaminants as well as moisture.

The terms used to categorize speed ranges, temperatures and loads for grease lubrication can differ from those used for bearings. Terms typically used for grease lubricated bearings are defined in the following tables:

- **table 1:** speed ranges for grease lubricated radial bearings
- **table 2:** grease temperature
- **table 3:** load ranges for greases

The quantity of grease applied to a bearing depends on the application. Too little grease leads to metal-to-metal contact and premature bearing failure. Excessive amounts of grease cause the operating temperature within the bearing to rise rapidly, particularly when running at high speeds. Bearings with seals or shields (capped bearings) are filled by SKF with a sufficient amount of grease to provide long bearing service life.

Depending on the speed range (→ **table 1**), SKF recommends the following grease fill percentages for bearings:

- 100% for slow speeds
- 30–50% for medium to high speeds

The free volume in the housing should be partly filled with grease. Before operating at full speed, the excess grease in the bearing must be given time to settle or escape during a running-in period. At the end of the running-in period, the operating temperature drops considerably, indicating that the grease has been distributed in the bearing arrangement.

In applications where bearings operate at very slow speeds and good protection against contaminants and corrosion is required, SKF recommends filling the housing up to 90% with grease.

Table 1

Speed ranges for grease lubricated radial bearings

Speed range	Speed factor Ball bearings	Needle roller, spherical roller, tapered roller, CARB toroidal roller bearings	Cylindrical roller bearings
–			
mm/min			
VL	Very slow	–	< 30 000
L	Slow	< 100 000	< 75 000
M	Medium	< 300 000	< 210 000
H	High	< 500 000	≥ 270 000
VH	Very high	< 700 000	–
EH	Extremely high	≥ 700 000	–

n = rotational speed [r/min]
 d_m = bearing mean diameter [mm]
 $= 0,5 (d + D)$

Note: Reliable grease life calculations can only be made considering the speed intervals listed in this table.

Table 2

Temperature ranges for greases

Temperature range	Range		
	°C	°F	
–	–		
L	Low	< 50	< 120
M	Medium	50 to 100	120 to 210
H	High	100 to 150	210 to 300
VH	Very high	> 150	> 300

Table 3

Load ranges for greases

Load range	Load ratio C/P	
	–	
L	Low	> 15
M	Medium	> 8
H	High	< 4
VH	Very high	< 2



Lubricating greases

Lubricating greases consist of a mineral or synthetic oil combined with a thickener. The thickeners are usually metallic soaps. However, other thickeners like polyurea are also available, and can be used in applications where there are, for example, high temperatures. Additives are also included to enhance certain properties of the grease. The consistency of the grease depends largely on the type and concentration of the thickener, and on the operating temperature of the application. When selecting a grease, the most important factors to be considered are:

- temperature range
- consistency
- base oil viscosity
- protection against corrosion
- load carrying ability
- miscibility

Temperature range – the SKF traffic light concept

The temperature range over which a grease can be used depends largely on the type of base oil and thickener as well as the additives. The relevant temperatures are schematically illustrated in **diagram 1** in the form of a “double traffic light”.

The extreme temperature limits, low and high, are well-defined.

- The low temperature limit (LTL), the lowest temperature at which a grease enables the bearing to be started up without difficulty, is largely determined by the base oil and its viscosity.
- The high temperature limit (HTL) is determined by the type of thickener and its dropping point. The dropping point is the temperature at which a grease loses its consistency and becomes a fluid.

As indicated in **diagram 1** by the red zones, SKF does not recommend using a grease above or below its temperature limits to lubricate bearings. Although grease suppliers indicate the specific values for the low and high temperature limits in their product literature, the temperatures for reliable operation are indicated by the SKF values for the following limits:

- low temperature performance limit (LTPL)
- high temperature performance limit (HTPL)

Within these two limits, which is indicated by the green zone in **diagram 1**, the grease fulfils its function reliably and the relubrication interval or grease life can be determined accurately. Since the definition of the high temperature performance limit is not standardized internationally, care must be taken when interpreting supplier data.

At temperatures above the high temperature performance limit (HTPL), grease degrades with increasing rapidity and the by-products of oxidation have a detrimental effect on the lubricant. Therefore, temperatures in the amber zone, between the high temperature performance limit (HTPL) and the high temperature limit (HTL), should only be allowed to occur for very short periods and not longer than a few hours.

Diagram 1

The SKF traffic light concept

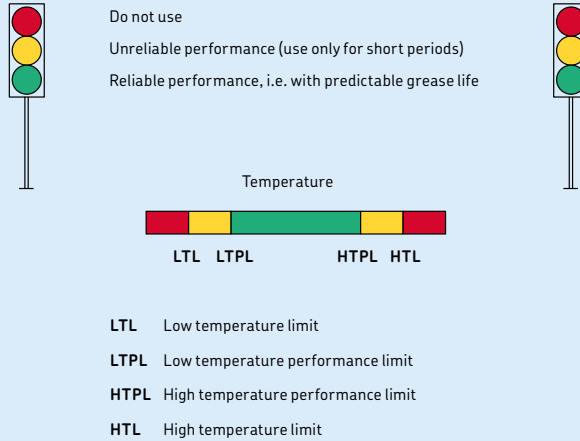

An amber zone also exists for low temperatures. With decreasing temperature, the consistency (stiffness) of grease increases and the tendency of grease to bleed decreases. This ultimately leads to an insufficient supply of lubricant reaching the contact surfaces of the rolling elements and raceways. In **diagram 1**, this temperature limit is indicated by the low temperature performance limit (LTPL). Values for the low temperature performance limit are different for roller bearings than for ball bearings. Since ball bearings are easier to lubricate than roller bearings, the low temperature performance limit is less important for ball bearings. For roller bearings, however, serious damage can result when the bearings are operated continuously below this limit. Short periods in this zone, such as during a cold start, are not harmful because the heat caused by frictional heat brings the bearing temperature into the green zone.

Temperature zones

Temperature zones differ from grease to grease and can only be determined by functional bearing testing.

Typical temperature zones for commonly available NLGI 2 greases without EP additives, which are normally used for rolling bearings, are shown in **diagram 2**. Since the data for each grease type is a summary of many greases of more or less similar composition, the transitions for each zone are not distinct, but fall within a certain range.

Temperature zones for SKF greases are shown in **diagram 3**. These temperature zones are based on extensive tests conducted in SKF laboratories.

The temperatures shown in **diagrams 2** and **3** relate to the measured temperature of the non-rotating ring in operation.

Consistency

Greases are divided into various consistency classes in accordance with the National Lubricating Grease Institute (NLGI). The consistency of lubricating grease should not change drastically when operated within its specified temperature range. Greases that soften at elevated temperatures may leak from the bearing arrangement. Those that stiffen at low temperatures may restrict bearing rotation or limit oil bleeding.

Greases with a metallic soap thickener and a consistency of 1, 2 or 3 on the NLGI scale are typically used for rolling bearings. The most common greases have a consistency of 2. Lower consistency greases are preferred for low temperature applications or to improve pumpability. Greases with a consistency of 3 are recommended for bearing arrangements with a vertical shaft where a baffle plate is arranged beneath the bearing to retain the grease in the bearing.

In applications subjected to vibration, the grease is heavily worked as it is continuously thrown back into the bearing by vibration. For these applications, higher consistency greases that do not change their consistency during operation may help.

Greases thickened with polyurea can soften or harden depending on the shear rate in the application. Therefore, in applications with vertical shafts, there is a danger that under

certain conditions, polyurea grease leaks, irrespective of the operating temperature.

Base oil viscosity

The base oil viscosity for greases typically used to lubricate rolling bearings lies between 15 and 500 mm²/s at 40 °C (105 °F). Greases based on oils having higher viscosities than 500 mm²/s at 40 °C (105 °F) bleed oil so slowly that the bearing may not be adequately lubricated. Therefore, if a viscosity higher than 500 mm²/s at 40 °C (105 °F) is required because of slow speeds, and for bearings operating at extremely high or low temperatures, extreme care must be taken. Under these conditions, contact the SKF application engineering service.

Base oil viscosity also governs the maximum recommended speed for a bearing. The permissible speed for grease is also influenced by the shear strength of the grease which is determined by the thickener. To indicate the speed capability, grease manufacturers often quote a speed factor, which can be calculated using

$$A = n d_m$$

where

A = speed factor [mm/min]

d_m = bearing mean diameter [mm]
= 0,5 (d + D)

n = rotational speed [r/min]

If the speed factor A exceeds 70% of the recommended limits (→ **table 5, page 257**), verify the influence of the selected lubricant on the speed limits that are provided under **Speeds** (→ **page 117**) and check whether the rotational speed is within these limits.

For extreme high-speed applications, contact the SKF application engineering service.

Diagram 2

The SKF traffic light concept – standard greases

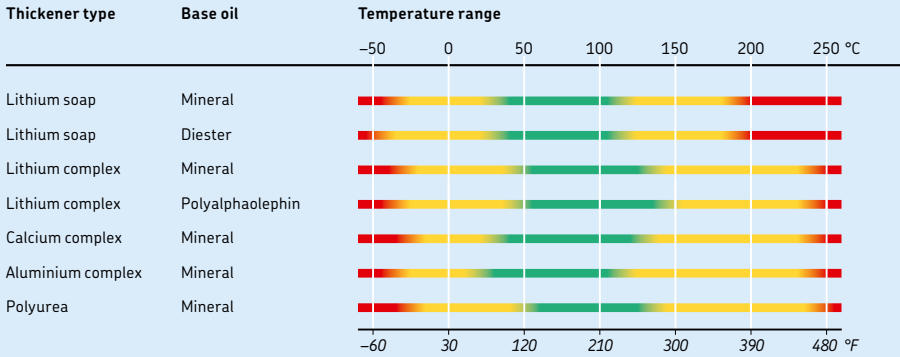
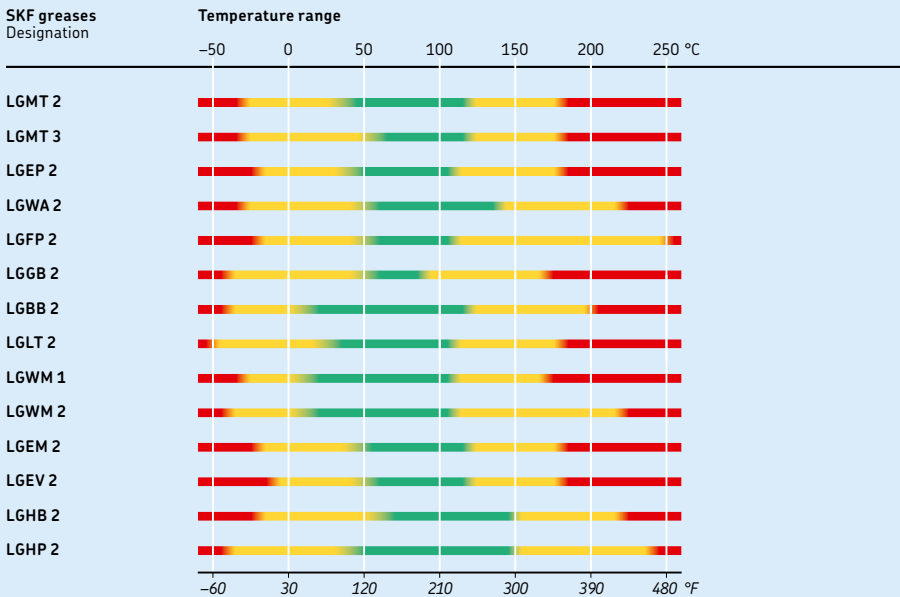

Diagram 3

The SKF traffic light concept – SKF greases



For operating temperatures > 150 °C (300 °F), SKF recommends SKF LGET 2 grease.



Protection against corrosion

Grease should also protect the bearing against corrosion and should not be washed out of the bearing arrangement if water is present. The type of thickener solely determines the ability of the grease to resist water washout. Thickeners with very good washout resistance include lithium complex, calcium complex, and polyurea greases. The ability of a grease to inhibit corrosion is determined by the properties of the rust inhibitor additive for that grease.

For very slow-speed applications, filling the housing up to 90% with grease can improve corrosion protection and help prevent the ingress of water.

Load carrying ability

If the thickness of the hydrodynamic lubricant film is not sufficient to prevent metal-to-metal contact, bearing service life can be extended significantly by using a lubricant containing extreme pressure (EP) or anti-wear (AW) additives.

In applications where $\kappa > 1$ (\rightarrow *Viscosity ratio* κ , page 241), SKF does not generally recommend using EP or AW additives. However, there are circumstances where EP/AW additives may be beneficial such as if excessive sliding between the rolling elements and raceways is expected.

Extreme pressure additives

EP (extreme pressure) additives are an option to overcome metal-to-metal contact of the asperities on the contact surfaces. Elevated temperatures, induced by local asperity contact, activate these additives, which promote mild chemical wear at the points of contact. The result is a smoother surface, lower contact stresses and extended bearing service life.

Some modern EP additives contain sulphur-phosphorus, which may become chemically active even without asperity contact. In these cases, high operating temperatures and/or contact stresses become the catalyst. The resulting chemical activity may not be restricted to the asperity contacts and can have a detrimental effect on the strength of the bearing steel matrix. This can promote corrosion/diffusion mechanisms in the contacts and may lead to accelerated bearing damage, usually initiated by micro spalls.

Therefore, SKF recommends using EP additives that are less reactive in applications with operating temperatures $> 80\text{ }^{\circ}\text{C}$ ($175\text{ }^{\circ}\text{F}$) and $< 100\text{ }^{\circ}\text{C}$ ($210\text{ }^{\circ}\text{F}$). For very slow speeds, solid lubricant additives such as graphite and molybdenum disulfide (MoS_2) can be used to enhance the EP effect. These additives should have a high purity level and a very small particle size. Otherwise, dents due to overrolling of the particles might reduce bearing service life.

For additional information about EP additives, contact the SKF application engineering service.

Anti-wear additives

AW (anti-wear) additives, like EP additives, prevent direct metal-to-metal contact. However, the way they work is very different. The main difference is that AW additives build a protective layer that adheres to the surface of the metal. The asperities can then slide over each other, avoiding direct contact. The surface finish is therefore not affected by mild wear as is the case with EP additives. Note that AW additives, like EP additives, may contain elements that can weaken the steel structure close to the surface.

Certain thickeners (e.g. calcium sulphonate complex) also provide an EP/AW effect without chemical activity and the resulting effect on bearing fatigue life. The temperature limits for these thickeners are well within the temperature limits of most greases and oils.

For additional information about AW additives, contact the SKF application engineering service.

Miscibility

If it becomes necessary to change from one grease to another, the miscibility or the ability to mix greases without adverse effects should be considered. If incompatible greases are mixed, the resulting consistency can change so dramatically that bearing damage due to severe leakage could result.

Greases with the same thickener and similar base oils can generally be mixed without any detrimental consequences. For example, a lithium thickener / mineral oil grease can generally be mixed with another lithium thickener / mineral oil grease. Also, some greases with different thickeners, such as

calcium complex and lithium complex, are miscible.

In cases where changing from one grease to another could cause low grease consistency and grease escaping from the bearing arrangement, all the old grease should be removed from the arrangement and the lubrication ducts (→ *Relubrication*, **page 252**).

The preservative with which SKF bearings are treated is compatible with the majority of lubricating greases with the possible exception of polyurea greases. Note that synthetic fluorinated oil based greases using a PTFE thickener, e.g. SKF LGET 2 grease, are not compatible with standard preservatives and the preservatives must be removed before applying grease.

For additional information, contact the SKF application engineering service.

WARNING

PTFE exposed to an open flame or temperatures above 300 °C (570 °F) are a health and environmental hazard! They remain dangerous even after they have cooled.

Read and follow the safety precautions under *Seal materials* (→ **page 155**).

SKF greases

The assortment of SKF greases for rolling bearings covers virtually all application requirements. These greases have been developed based on the latest information about rolling bearing lubrication. SKF continuously monitors the quality of its greases prior to use or sale.

The most important technical specifications for SKF greases, together with a quick selection guide, are provided in **table 4** (→ **page 250**). The temperature ranges where the SKF greases can be used are schematically illustrated according to the SKF traffic light concept in **diagram 3** (→ **page 247**).

For additional information about SKF greases, refer to the catalogue *SKF Maintenance and Lubrication Products* or visit skf.com/lubrication.

For a more detailed selection of the appropriate grease for a specific bearing type and application, use the internet based SKF grease selection program, SKF LubeSelect, available online at skf.com/lubrication.

SKF greases – technical specifications and characteristics

Designation	Description	Temperature	Speed	Load	NLGI class	Temperature range ¹⁾		Base oil viscosity at	
						LTL	HTPL	40 °C (105 °F)	100 °C (210 °F)
–	–	–	–	–	–	°C/°F		mm ² /s	
LGMT 2	General purpose, industrial and automotive	M	M	L to M	2	–30 –20	120 250	110	11
LGMT 3	General purpose, industrial and automotive	M	M	L to M	3	–30 –20	120 250	120	12
LGEP 2	Extreme pressure, heavy load	M	L to M	H	2	–20 –5	110 230	200	16
LGWA 2	Wide temperature ³⁾ , extreme pressure	M to H	L to M	L to H	2	–30 –20	140 285	185	15
LGFP 2	Food compatible	M	M	L to M	2	–20 –5	110 230	130	7,3
LGGB 2	Green biodegradable, low toxicity	L to M	L to M	M to H	2	–40 –40	90 ²⁾ 195	110	13
LGBB 2	Wind turbine blade and yaw bearing grease	L to M	VL	M to H	2	–40 –40	120 250	68	10
LGLT 2	Low temperature, extremely high speeds	L to M	M to EH	L	2	–50 –60	110 230	18	4,5
LGWM 1	Extreme pressure, low temperature	L to M	L to M	H	1	–30 –20	110 230	200	16
LGWM 2	Heavy load, wide temperature	L to M	L to M	M to H	2	–40 –40	110 230	80	8,6
LGEM 2	High viscosity, solid lubricants	M	VL	H to VH	2	–20 –5	120 250	500	32
LGEV 2	Extremely high viscosity, solid lubricants	M	VL	H to VH	2	–10 –15	120 250	1020	58
LGHB 2	EP high viscosity, high temperature ⁴⁾ ,	M to H	VL to M	L to VH	2	–20 –5	150 300	400	26,5
LGHP 2	High performance polyurea grease	M to H	M to H	L to M	2	–40 –40	150 300	96	10,5
LGEB 2	Extreme temperature	VH	L to M	H to VH	2	–40 –40	260 500	400	38

¹⁾ LTL: Low temperature limit HTPL: High temperature performance limit

²⁾ LGGB 2 can withstand temperature peaks of 120 °C (250 °F)

³⁾ LGWA 2 can withstand temperature peaks of 220 °C (430 °F)

⁴⁾ LGHB 2 can withstand temperature peaks of 200 °C (390 °F)

Table 4

Designation	Vertical shaft	Fast outer ring rotation	Oscillation movements	Severe vibrations	Shock load or frequent start-up	Low noise	Low friction	Rust inhibiting properties
-								
LGMT 2	○	-	-	+	-	-	○	+
LGMT 3	+	○	-	+	-	-	○	○
LGEP 2	○	-	○	+	+	-	○	+
LGWA 2	○	○	○	○	+	-	○	+
LGFP 2	○	-	-	-	-	-	○	+
LGGB 2	○	-	+	+	+	-	-	○
LGBB 2	-	-	+	+	+	-	-	+
LGLT 2	○	-	-	-	○	+	+	○
LGWM 1	-	-	+	-	+	-	-	+
LGWM 2	○	○	+	+	+	-	-	+
LGEM 2	○	-	+	+	+	-	-	+
LGEV 2	○	-	+	+	+	-	-	+
LGHB 2	○	+	+	+	+	-	-	+
LGHP 2	+	-	-	○	○	+	○	+
LGET 2	○	+	+	○	○	-	-	○

Symbols: + Recommended
 ○ Suitable
 - Not suitable

G

Relubrication

Rolling bearings have to be relubricated if the service life of the grease is shorter than the expected service life of the bearing. Relubrication should always occur while the existing lubricant is still satisfactory.

The time at which the bearing should be relubricated depends on many related factors. These include:

- bearing type and size
- speed
- operating temperature
- grease type
- space around the bearing
- bearing environment

It is only possible to base recommendations on statistical rules. The SKF relubrication intervals are defined as the time period, at the end of which 99% of the bearings are still reliably lubricated. This represents the L_{-1} grease life.

SKF recommends using experience based data from actual applications and tests, together with the estimated relubrication intervals provided.

For many applications, there is a temperature limit for standard greases when the bearing ring with the highest temperature exceeds an operating temperature of 100 °C (210 °F). Above this temperature, special greases should be used. In addition, the temperature limits of the bearing and adjacent machine components, such as external seals, should be taken into consideration.

For additional information about high temperature applications, contact the SKF application engineering service.

Relubrication intervals

The relubrication intervals t_f for bearings with a rotating inner ring on horizontal shafts under normal and clean operating conditions can be obtained from **diagram 4** (→ **page 256**) as a function of:

- the speed factor A multiplied by the relevant bearing factor b_f

where

$A = n d_m$ [mm/min]

b_f = bearing factor dependent on bearing type and load conditions (→ **table 5, page 257**)

d_m = bearing mean diameter [mm]
= 0,5 (d + D)

n = rotational speed [r/min]

- the load ratio C/P

The relubrication interval t_f is the estimated number of operating hours that a high-quality grease, consisting of mineral oil and a lithium base thickener, can perform adequately when the operating temperature is 70 °C (160 °F). When bearing operating conditions differ, the relubrication intervals (→ **diagram 4, page 256**) need to be adjusted (→ *Adjustments of relubrication intervals due to operating conditions and bearing types*).

If the speed factor A exceeds 70% of the recommended limits (→ **table 5, page 257**), verify the influence of the selected lubricant on the speed limits that are provided under *Speeds* (→ **page 117**) and check whether the rotational speed is within these limits.

When using high performance greases, an extended relubrication interval and grease life may be possible.

For grease life of capped bearings, refer to the relevant product chapters.

For additional information, contact the SKF application engineering service.

Adjustments of relubrication intervals due to operating conditions and bearing types

Operating temperature

To account for the accelerated ageing of grease with increasing temperature, SKF recommends halving the obtained intervals (→ **diagram 4, page 256**) for every 15 °C (27 °F) increase in operating temperature above 70 °C (160 °F). The high temperature performance limit HTPL for the grease (→ **diagram 1, page 245**) should not be exceeded.

The relubrication interval t_f may be extended at temperatures below 70 °C (160 °F) if the temperature is not close to the lower temperature performance limit LTPL (→ **diagram 1, page 245**). SKF does not recommend extending the relubrication interval t_f by more than a factor of two.

Do not extend the obtained t_f values (→ **diagram 4, page 256**) for full complement bearings or thrust roller bearings. Moreover, it is not advisable to use relubrication intervals in excess of 30 000 hours.

Vertical shafts

For bearings on vertical shafts, the intervals obtained from **diagram 4** (→ **page 256**) should be halved.

The use of an effective seal, shield or baffle plate is a prerequisite to prevent grease leaking from the bearing arrangement.

Vibration

Moderate vibration does not have a negative effect on grease life. However, high vibration and shock levels, such as those in vibrating screen applications, cause the grease to churn. In these cases, the relubrication interval should be reduced. If, during operation, the grease becomes too soft, use a more mechanically stable grease, e.g. SKF LGHB 2 or grease with higher stiffness up to NLGI 3.

Outer ring rotation

In applications where the outer ring rotates, the speed factor A is calculated differently. In this case, use the bearing outside diameter D instead of d_m . The use of an effective seal is a prerequisite to avoid grease leakage.

In applications where there are high outer ring speeds (i.e. > 40% of the reference speed listed in the product tables), greases with good oil bleeding properties should be applied.

For spherical roller thrust bearings with a rotating housing washer, oil lubrication is recommended.

Contamination

In applications where the ingress of solid contaminants is an issue, more frequent relubrication than indicated by the relubrication interval is necessary. Relubrication reduces the level of contamination while reducing the damaging effects caused by overrolling the

particles. Liquid contaminants such as water and/or process fluids also require a reduced relubrication interval. In case of severe contamination, continuous relubrication should be considered.

Lubrication

Very slow speeds

Selecting the proper grease and grease fill is very important for slow speed applications. Bearings that operate at very slow speeds under light loads require a low consistency grease. Bearings that operate at slow speeds under heavy loads should be lubricated with a grease that has a high viscosity base oil containing EP additives.

Solid additives such as graphite and molybdenum disulfide (MoS_2) can be considered for a speed factor $A < 20\,000$ mm/min.

High speeds

Relubrication intervals for bearings used at speeds above the recommended speed factor A (→ **table 5, page 257**) should only be applied when using special greases or modified bearing executions such as hybrid bearings. In these cases, continuous relubrication techniques such as circulating oil or the oil-air method are more effective than grease.

Heavy and very heavy bearing loads

For bearings operating at a speed factor $A > 20\,000$ mm/min and subjected to a load ratio $C/P < 4$, the relubrication interval is reduced to the point that SKF recommends continuous grease relubrication or the oil bath lubrication method.

In applications where the speed factor $A < 20\,000$ mm/min and the load ratio $C/P = 1-2$, refer to *Very slow speeds*.

For heavy loads and high speeds, SKF generally recommends a circulating oil system with auxiliary cooling.

Very light bearing loads

In many cases, the relubrication interval can be extended if the loads are light, i.e. $C/P = 30$ to 50. To obtain satisfactory operation, the bearings should be subjected to the minimum load as stated in the relevant product chapters.

Misalignment

Static misalignment, within the permissible limits, does not adversely affect grease life in spherical roller bearings, self-aligning ball bearings or CARB toroidal roller bearings.

Large bearings

Large roller bearings, $d > 300$ mm, used in process machinery, require a proactive approach. For these critical applications, SKF recommends strict adherence to the relubrication quantities but with shorter initial relubrication intervals.

Prior to relubrication, check the used grease for both solid and liquid contaminants. Also, check the sealing system completely, looking for wear, damage and leaks. If, over time, the condition of the grease and associated components is found to be satisfactory, the relubrication interval can be increased gradually.

SKF recommends a similar procedure for spherical roller thrust bearings, prototype machines and upgrades of high-density power equipment or wherever application experience is limited.

Cylindrical roller bearings

The relubrication intervals (→ **diagram 4, page 256**) are valid for cylindrical roller bearings fitted with:

- a glass fibre reinforced PA66 cage, roller centred, designation suffix P
- a machined brass cage, roller centred, designation suffix M

The obtained relubrication intervals (→ **diagram 4, page 256**) should be halved and a grease with good oil bleeding properties should be applied to cylindrical roller bearings with:

- a stamped steel cage, roller centred, no designation suffix or suffix J
- a machined brass cage, inner or outer ring centred, designation suffixes MA, MB, MH, ML or MP
- a sheet steel cage, inner or outer ring centred, designation suffixes JA or JB

Observations

If, during testing, the determined value for the relubrication interval t_r is too short for a particular application, SKF recommends the following:

- Check the bearing operating temperature.
- Check whether the grease contains solid or liquid contaminants.
- Check the operating conditions, e.g. load or misalignment.
- Check whether a more suitable grease is necessary.

Relubrication intervals at operating temperatures of 70 °C (160 °F)

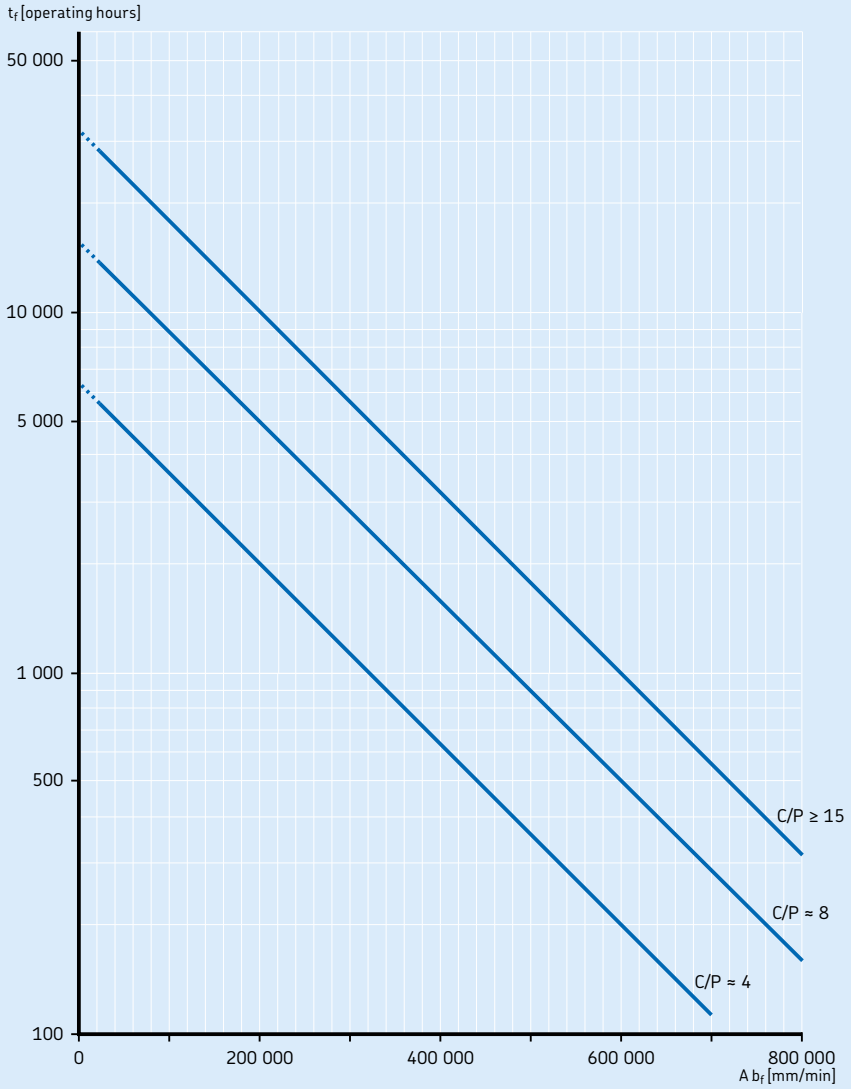

Table 5

Bearing factors and recommended limits for speed factor A

Bearing type ¹⁾	Bearing factor b_f	Recommended limits for speed factor A for load ratio		
		$C/P \geq 15$	$C/P = 8$	$C/P = 4$
–	–	mm/min		
Deep groove ball bearings	1	500 000	400 000	300 000
Y-bearings	1	500 000	400 000	300 000
Angular contact ball bearings	1	500 000	400 000	300 000
Self-aligning ball bearings	1	500 000	400 000	300 000
Cylindrical roller bearings				
– non-locating bearing	1,5	450 000	300 000	150 000
– locating bearing, without external axial loads or with light but alternating axial loads	2	300 000	200 000	100 000
– locating bearing, with constantly acting light axial load	4	200 000	120 000	60 000
– without a cage, full complement ²⁾	4	NA ³⁾	NA ³⁾	20 000
Needle roller bearings				
– with a cage	3	350 000	200 000	100 000
– without a cage, full complement	Contact the SKF application engineering service.			
Tapered roller bearings	2	350 000	300 000	200 000
Spherical roller bearings				
– when the load ratio $F_a/F_r \leq e$ and $d_m \leq 800$ mm				
series 213, 222, 238, 239	2	350 000	200 000	100 000
series 223, 230, 231, 232, 240, 248, 249	2	250 000	150 000	80 000
series 241	2	150 000	80 000 ⁴⁾	50 000 ⁴⁾
– when the load ratio $F_a/F_r \leq e$ and $d_m > 800$ mm				
series 238, 239	2	230 000	130 000	65 000
series 230, 231, 232, 240, 248, 249	2	170 000	100 000	50 000
series 241	2	100 000	50 000 ⁴⁾	30 000 ⁴⁾
– when the load ratio $F_a/F_r > e$				
all series	6	150 000	50 000 ⁴⁾	30 000 ⁴⁾
CARB toroidal roller bearings				
– with a cage	2	350 000	200 000	100 000
– without a cage, full complement ²⁾	4	NA ³⁾	NA ³⁾	20 000
Thrust ball bearings	2	200 000	150 000	100 000
Cylindrical roller thrust bearings	10	100 000	60 000	30 000
Needle roller thrust bearings	10	100 000	60 000	30 000
Spherical roller thrust bearings				
– rotating shaft washer	4	200 000	120 000	60 000
Track runner bearings	Contact the SKF application engineering service.			

¹⁾ The bearing factors and recommended speed factor A limits apply to bearings with standard internal geometry and standard cage execution. For alternative internal bearing design and special cage execution, contact the SKF application engineering service.

²⁾ The t_f value obtained from **diagram 4** needs to be divided by a factor of 10.

³⁾ Not applicable, as a bearing with a cage is recommended for these C/P values.

⁴⁾ For higher speeds, oil lubrication is recommended.



Relubrication procedures

The relubrication procedure generally depends on the application and on the relubrication interval t_r . SKF recommends one of the following procedures:

- Replenishment is a convenient and preferred procedure if the relubrication interval is shorter than six months. It enables uninterrupted operation and provides, when compared with continuous relubrication, a lower steady state temperature.
- Renewing the grease fill is generally recommended when the relubrication interval is longer than six months. This procedure is often applied as part of a bearing maintenance schedule.
- Continuous relubrication is used when the estimated relubrication intervals are short due to the adverse effects of contamination, or when other relubrication methods are inconvenient because access to the bearing is difficult. SKF does not recommend continuous relubrication for applications with high rotational speeds since the intensive churning of the grease can lead to very high operating temperatures and destruction of the grease thickener structure.

When using different bearings in a bearing arrangement, it is common practice to apply the lowest estimated relubrication interval for all bearings in the arrangement. The guidelines and grease quantities for the three alternative procedures are provided below.

Replenishment

As mentioned in the introduction of *Lubrication*, the free volume in the bearing should be completely filled during installation, while the free volume in the housing generally should be partly filled. Depending on the intended method of replenishment, SKF recommends the following grease fill percentages for this free volume in the housing:

- 40% when replenishing from the side of the bearing (→ **fig. 1**).
- 20% when replenishing through the lubrication holes in the bearing inner or outer ring (→ **fig. 2**).

Suitable quantities for replenishment from the side of a bearing can be obtained from

$$G_p = 0,005 D B$$

and for replenishment through the bearing outer or inner ring from

$$G_p = 0,002 D B$$

where

G_p = grease quantity to be added when replenishing [g]

B = total bearing width [mm]
(for tapered roller bearings use T ,
for thrust bearings use height H)

D = bearing outside diameter [mm]

Fig. 1

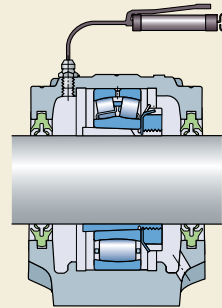
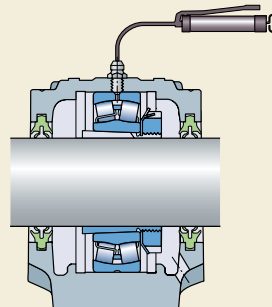

Fig. 2



To apply grease with a grease gun, a grease fitting is needed on the housing. If contact seals are used, an escape hole in the housing should also be provided so that excess grease does not build up in the space surrounding the bearing (→ **figs. 1 and 2**). Otherwise, this can cause a permanent increase in bearing temperature. The escape hole should be plugged when high-pressure water is used for cleaning.

Excess grease collecting in the space surrounding the bearing can cause temperature peaks, which can have a detrimental effect on the grease as well as the bearing. It is more pronounced when bearings operate at high speeds. In these cases, SKF recommends using a grease flinger in combination with an escape hole. This prevents over-lubrication and enables relubrication to be performed while the machine is in operation. A grease flinger is basically a disc that rotates with the shaft and forms a narrow gap together with the housing end cover (→ **fig. 3**). Excess and used grease is flung into an annular cavity and leaves the housing through an opening on the underside of the end cover.

For additional information about the design and dimensioning of grease flingers, contact the SKF application engineering service.

To be sure that fresh grease actually reaches the bearing and replaces the old grease, the lubrication duct in the housing should either feed the grease adjacent to the outer ring side face (→ **figs. 1 and 4**) or, preferably, into the bearing. To facilitate efficient lubrication, some bearing types, e.g. spherical roller bearings, are provided with an annular groove and/or one or more lubrication holes in the inner or outer ring (→ **figs. 2 and 5**).

Fig. 3

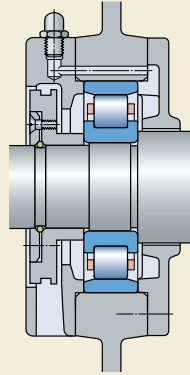

Fig. 4

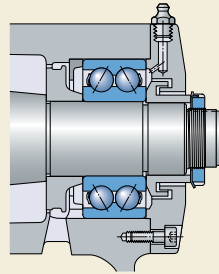
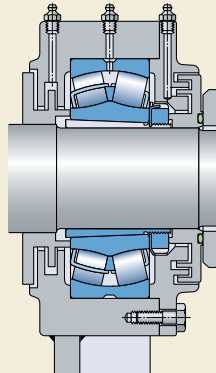

Fig. 5



To effectively replace used grease, it is important to relubricate the bearing while the machine is in operation. In cases where the machine is not in operation, the bearing should be rotated during replenishment. When lubricating the bearing directly through the inner or outer ring, the fresh grease is applied directly to the free volume in the bearing. Therefore, the amount of grease needed is reduced, when compared with relubricating from the side. It is assumed that the lubrication ducts were filled with grease during the mounting process. If not, a larger quantity of grease is needed to compensate for the empty ducts during the first replenishment.

Where long lubrication ducts are used, check whether the grease can be adequately pumped at the prevailing ambient temperature.

The grease in the housing should be replaced when the free volume in the housing is approximately 75% full. When relubricating from the side and starting with 40% initial fill of the housing, the complete grease fill should be replaced after approximately five replenishments. Due to the lower initial fill of the housing and the reduced topping-up quantity during replenishment when relubricating the bearing directly through the inner or outer ring, renewal is only required in exceptional cases.

Renewing the grease fill

When renewing the grease fill at the estimated relubrication interval or after a certain number of replenishments, the used grease in the bearing and housing should be completely removed and replaced. The used grease should be disposed of in an environmentally safe and responsible way.

Filling the bearing and housing with grease should be done in accordance with the guidelines provided under *Replenishment* (→ page 258).

To renew the grease fill, the housing should be accessible and easily opened. The cap of split housings and the covers of non-split housings can usually be removed to expose the bearing. After removing the used grease, fresh grease should first be packed between the rolling elements. Precautions should be taken to prevent contaminants from being introduced into the bearing, housing or grease container. SKF recommends using grease resistant gloves to prevent any allergic skin reactions.

When housings are less accessible, but are provided with grease fittings and escape holes, it is possible to completely renew the grease fill by relubricating several times in close succession until fresh grease is purged from the housing. This procedure requires much more grease than is needed for manual renewal. In addition, this method of renewal has speed limitations. At high speeds, temperatures can increase as a result of grease churning.

Continuous relubrication

This procedure is used when the calculated relubrication interval is very short, e.g. due to the adverse effects of contamination, or when other procedures of relubrication are inconvenient, e.g. access to the bearing is difficult. Due to the excessive churning of the grease, which can lead to increased temperature, continuous lubrication is only recommended when rotational speeds are relatively slow such as the following speed factors:

- $A < 150\,000$ mm/min for ball bearings
- $A < 75\,000$ mm/min for roller bearings

In these cases, the initial grease fill for the housing can be up to 90% and the quantity for relubrication per time unit is derived from the equations for G_p (→ *Replenishment*, **page 258**) by spreading the required quantity over the relubrication interval.

When using continuous relubrication, check whether the grease can be adequately pumped through the ducts at the prevailing ambient temperature.

Continuous lubrication can be achieved via single-point or multi-point automatic lubricators, e.g. SKF SYSTEM 24 or SKF MultiPoint Lubricator.

For additional information, contact the SKF application engineering service.

Centralized lubrication systems, such as SKF Monoflex, SKF ProFlex, SKF Duoflex and SKF Multiflex, can reliably deliver grease in a wide range of quantities. For additional information about SKF lubrication systems, visit skf.com/lubrication.

Oil lubrication

Oil is generally used to lubricate rolling bearings when:

- high speeds or operating temperatures preclude the use of grease
- excessive heat has to be removed from the bearing position
- adjacent components (gears etc.) are lubricated with oil

To extend bearing service life, all methods of bearing lubrication that use clean oil are acceptable. These include:

- the circulating oil lubrication method
- the oil jet method
- the oil-air method

When using the circulating oil or oil-air method, adequately dimensioned ducts should be provided so that oil flowing from the bearing can leave the arrangement.

Oil lubrication methods

Oil bath

The simplest method of oil lubrication is the oil bath (→ **fig. 6**). The oil, which is picked up by the rotating components of the bearing, is distributed within the bearing and then flows back to the sump in the housing. The oil level should almost reach the centre of the lowest rolling element when the bearing is stationary. SKF recommends the use of oil levellers such as the SKF LAHD 500 to maintain the correct oil level.

When operating at high speed, the oil level can drop significantly and the housing can become overfilled by the oil leveller. If this occurs, contact the SKF application engineering service.

Fig. 6

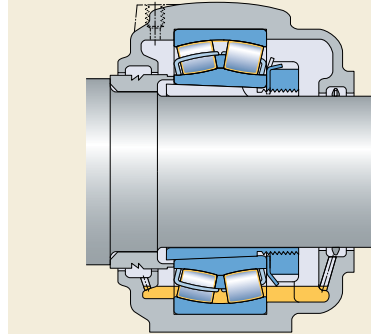

Oil pick-up ring

For bearing applications where speeds and operating temperatures require oil to be delivered reliably, SKF recommends using an oil pick-up ring (→ **fig. 7**). The pick-up ring hangs loosely on a sleeve on the shaft on one side of the bearing and dips into the oil sump in the lower half of the housing. As the shaft rotates, the ring follows and transports oil from the sump to a collecting trough. The oil then flows through the bearing back into the sump. SKF SONL plummer block housings are designed for the oil pick-up ring lubrication method.

For additional information, contact the SKF application engineering service.

Circulating oil

High-speed operation increases the operating temperature and accelerates ageing of the oil. To avoid frequent oil changes and to achieve a fully flooded lubrication condition, the circulating oil lubrication method is generally preferred (→ **fig. 8**). Circulation is usually controlled by a pump. After the oil has passed through the bearing, it generally settles in a tank where it is filtered and, if required, cooled before being returned to the bearing. Proper filtering decreases the contamination level and extends bearing service life (→ *SKF rating life*, **page 64**). Cooling the oil can also significantly reduce the operating temperature of the bearing.

Fig. 7

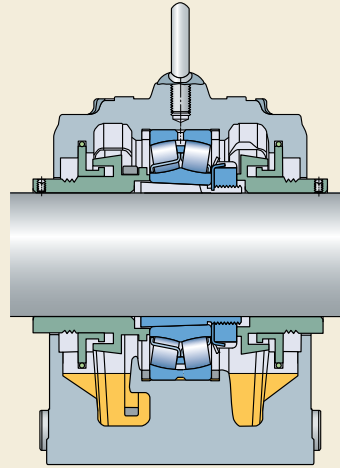
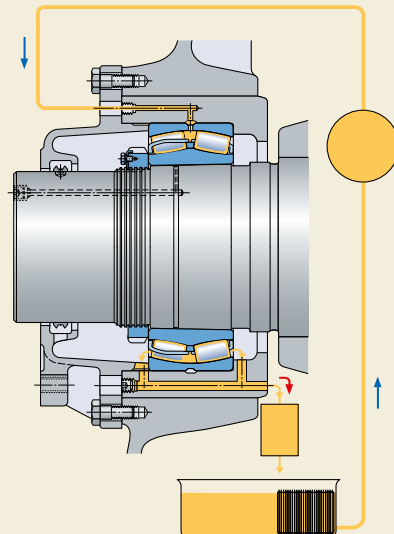

Fig. 8



G

Lubrication

Oil jet

For very high-speed operation, a sufficient but not excessive amount of oil must be supplied to the bearing to provide adequate lubrication, without increasing the operating temperature more than necessary. One particularly effective method of achieving this is the oil jet method (→ **fig. 9**). A jet of oil under high pressure is directed at the side of the bearing. The velocity of the oil jet must be sufficiently high (≥ 15 m/s) to penetrate the turbulence surrounding the rotating bearing.

Oil-air

With the oil-air method (→ **fig. 10**) – also called the oil-spot method – compressed air is mixed with very small, accurately metered quantities of oil and directed at each bearing. This minimum quantity lubrication method enables bearings to operate at lower temperatures or at higher speeds than any other lubrication method. The compressed air serves to cool the bearing and also produces an excess pressure in the bearing housing to prevent contaminants from entering.

For additional information about the design of oil-air lubrication arrangements, visit skf.com/lubrication.

Oil mist

Oil mist lubrication has not been recommended for some time due to possible negative environmental effects.

A new generation of oil mist generators permits to produce oil mist with 5 ppm oil. New designs of special seals also limit the amount of stray mist to a minimum. In case synthetic non-toxic oil is used, the environmental effects are even further reduced. Oil mist lubrication today is used in very specific applications, like the petroleum industry.

Fig. 9

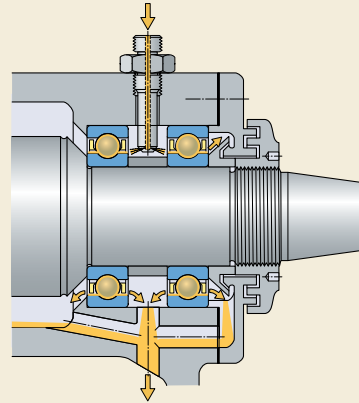
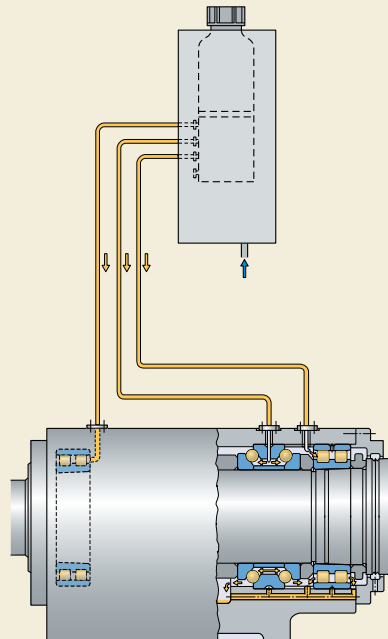

Fig. 10



Lubricating oils

Straight mineral oils are generally the favoured lubricant for lubricating rolling bearings. Oils containing extreme pressure (EP) or anti-wear (AW) additives to improve lubricant properties are generally used only in special cases. The information covering EP and AW additives in grease (→ *Load carrying ability*, page 248) also apply to these additives in oils.

Synthetic versions of many of the popular lubricant classes are available. Synthetic oils are generally only considered for bearing lubrication in extreme cases, e.g. at very low or very high operating temperatures. The term, synthetic oil, covers a wide assortment of different base stocks. The main ones are poly-alphaolefins (PAO), esters and polyalkylene glycols (PAG). These synthetic oils have different properties than mineral oils (→ table 6).

The thickness of the hydrodynamic film, which prevents metal-to-metal contact in a bearing, plays a major role in bearing fatigue life. The thickness of the hydrodynamic film is determined, in part, by the viscosity index (VI) and the pressure-viscosity coefficient. For most mineral oil based lubricants, the pressure-viscosity coefficient is similar, and generic values obtained from literature can be used. However, for synthetic oils, the effect on viscosity to increasing pressure is determined by the chemical structure of its base stock. As a result, there is considerable variation in pressure-viscosity coefficients for different types of synthetic base stocks. Due to the differences in the viscosity index and pressure-

viscosity coefficient, it should be remembered that the formation of a hydrodynamic lubricant film, when using a synthetic oil, may differ from that of a mineral oil with the same viscosity. For additional information about synthetic oils, contact the lubricant supplier.

In addition, additives play a role in the formation of a hydrodynamic film. Due to differences in solubility, different types of additives are used in synthetic oils that are not included in mineral oil based lubricants.

Table 6

Properties of lubricating oil types

Properties	Base oil type				
	Mineral	PAO	Ester	PAG	
Pour point	[°C]	-30 .. 0	-50 .. -40	-60 .. -40	appr. -30
	[°F]	-20 .. 30	-60 .. -40	-75 .. -40	appr. -20
Viscosity index	low	moderate	high	high	high
Pressure-viscosity coefficient	high	moderate	low to moderate	low to moderate	moderate

G

Selecting lubricating oils

Selecting oil is primarily based on the viscosity required to form a sufficiently thick hydrodynamic film at normal operating temperature. The viscosity of oil is temperature dependent, becoming lower as the temperature rises. The viscosity-temperature relationship of an oil is characterized by the viscosity index (VI). For rolling bearings, oils with a viscosity index of at least 95 (little change with temperature) are recommended.

To form a sufficiently thick oil film in the contact area between the rolling elements and raceways, the oil must retain a minimum viscosity at normal operating temperature. The rated viscosity v_1 required at normal operating temperature to provide adequate lubrication can be determined from **diagram 5** (→ **page 268**), provided a mineral oil is used. When the operating temperature is known from experience or can otherwise be determined, the corresponding viscosity at the internationally standardized reference temperature of 40 °C (105 °F), i.e. the oil ISO VG viscosity class, can be obtained from **diagram 6** (→ **page 269**), which is compiled for a viscosity index of 95.

Certain bearing types, such as spherical roller bearings, toroidal roller bearings, tapered roller bearings, and spherical roller thrust bearings, typically have a higher operating temperature than other bearing types such as ball bearings and cylindrical roller bearings, under comparable operating conditions.

When selecting an oil, consider the following:

- Bearing life may be extended by selecting an oil where the viscosity v at normal operating temperature is higher than the obtained viscosity v_1 (→ **diagram 5, page 268**). The condition $v > v_1$ can be obtained by choosing a mineral oil with a higher ISO VG viscosity class or by selecting an oil with a higher viscosity index, provided the oil has the same pressure-viscosity coefficient. Since higher viscosity increases operating temperature, there is frequently a practical limit to the lubrication improvement that can be obtained using this method.
- If the viscosity ratio $\kappa < 1$ (→ *Viscosity ratio κ* , **page 241**), SKF recommends using an oil containing EP additives. If $\kappa < 0,4$ an oil with EP additives must be used. Oils with EP additives may also enhance operational reliability in cases where $\kappa > 1$ and medium- and large-size roller bearings are used. It should be remembered that some EP additives may cause adverse effects.
- For exceptionally slow or high speeds, for critical loading conditions, or for unusual lubricating conditions, contact the SKF application engineering service.

Example

A bearing with a bore diameter $d = 340$ mm and an outside diameter $D = 420$ mm is required to rotate at a speed $n = 500$ r/min. What is the required viscosity v at the reference temperature of 40 °C (105 °F)?

From **diagram 5** (→ **page 268**) with $d_m = 0,5(340 + 420) = 380$ mm and $n = 500$ r/min, the rated viscosity v_1 required for adequate lubrication at normal operating temperature is approximately 11 mm²/s. From **diagram 6** (→ **page 269**), assuming that the normal operating temperature is 70 °C (160 °F), a lubricating oil in the ISO VG 32 viscosity class, with an actual viscosity $v \geq 32$ mm²/s at the reference temperature of 40 °C (105 °F), is required.

Oil change

How frequently oil changes are needed depends mainly on the operating conditions and the quantity of oil.

With the oil bath lubrication method, it is generally sufficient to change the oil once a year, provided the operating temperature does not exceed 50 °C (120 °F) and there is little risk of contamination. Higher temperatures require more frequent oil changes, e.g. for operating temperatures around 100 °C (210 °F), the oil should be changed every three months. Frequent oil changes are also necessary if other operating conditions are arduous.

With circulating oil lubrication systems, the period between oil changes is also determined by how frequently the total oil quantity is circulated and whether or not the oil is cooled. It is only possible to determine a suitable interval through testing and regular inspection to see that the oil is not contaminated or excessively oxidized. The same applies for the oil jet lubrication method. With the oil-air lubrication method, the oil only passes through the bearing once and is not recirculated.

Estimation of the rated viscosity ν_1 at operating temperature

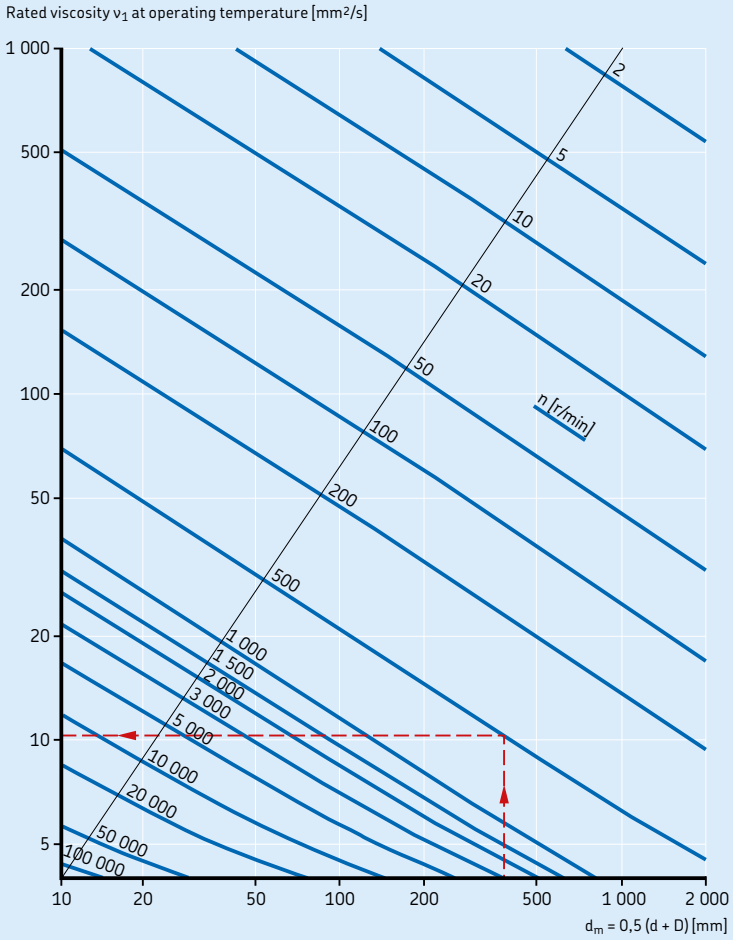
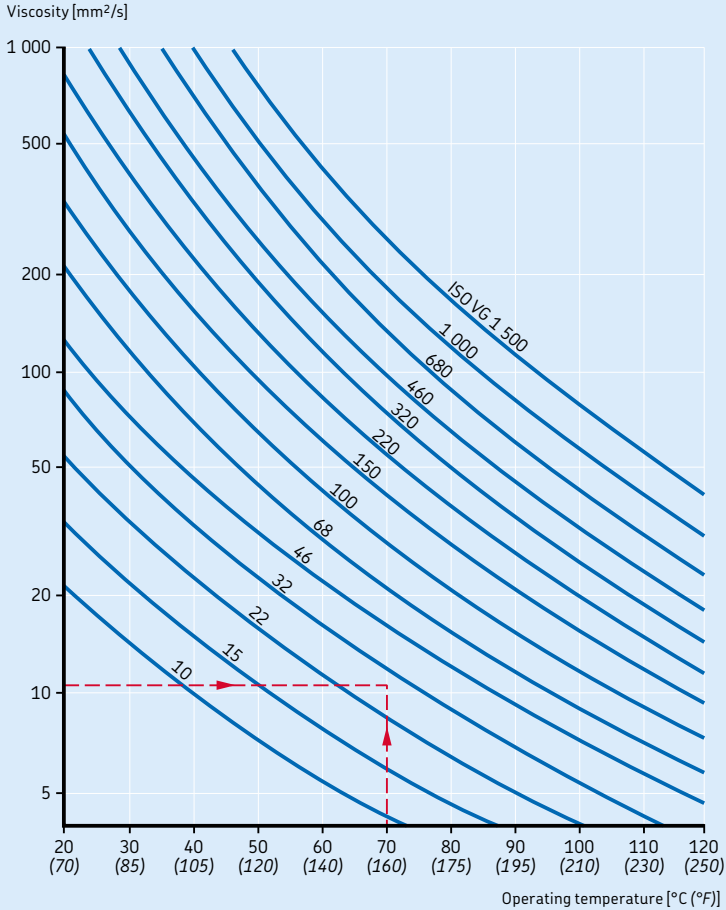
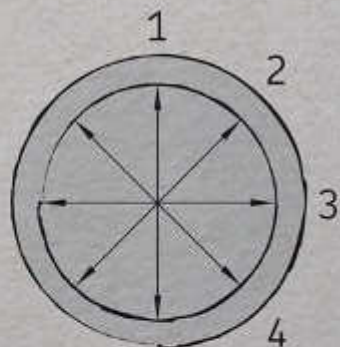
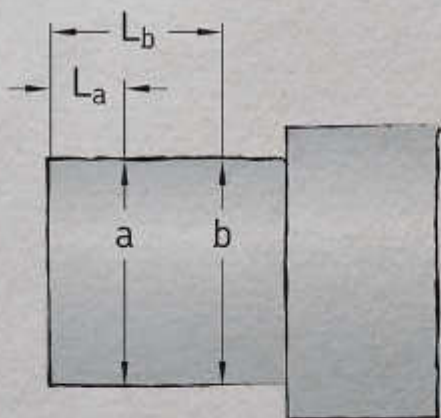

Diagram 6

Viscosity-temperature diagram for ISO viscosity grades
(Mineral oils, viscosity index 95)





Mounting, dismounting and bearing care

General	272
Where to mount	272
Preparations prior to mounting or dismounting	272
Bearing handling	274
Mounting	275
Mounting bearings with a cylindrical bore	275
Cold mounting	275
Hot mounting	276
Bearing adjustment	277
Mounting bearings with a tapered bore	278
Small and medium-size bearings	278
Medium- and large-size bearings	278
Obtaining an interference fit	280
Test running	284
Machines on standby	284
Dismounting	285
Dismounting bearings fitted on a cylindrical shaft seat	285
Cold dismounting	285
Hot dismounting	286
Dismounting bearings fitted on a tapered shaft seat	287
Dismounting bearings fitted on an adapter sleeve	288
Dismounting bearings fitted on a withdrawal sleeve	290
Bearing storage	291
Storage conditions	291
Shelf life of open bearings	291
Shelf life of capped bearings	291
Inspection and cleaning	291



General

Rolling bearings are reliable machine elements that can provide long service life, provided they are mounted and maintained properly. Proper mounting requires experience, accuracy, a clean work environment and the appropriate tools.

To promote proper installation techniques, speed, accuracy and safety, SKF offers a comprehensive assortment of high quality installation and maintenance products. The assortment includes everything from mechanical and hydraulic tools to bearing heaters and grease. For information about SKF maintenance products, refer to the product information available online at skf.com/mapro.

Mounting bearings correctly is often more difficult than it appears, especially where large bearings are concerned. To be sure that bearings are mounted and maintained properly, SKF offers seminars and hands-on training courses as part of the SKF Reliability Systems concept. Installation and maintenance assistance may also be available from your local SKF company or SKF Authorized Distributor.

The information provided in the following section is quite general and is intended primarily to indicate what must be considered by machine and equipment designers to facilitate bearing mounting and dismounting. For additional information about mounting and dismounting procedures, refer to the *SKF bearing maintenance handbook*.

Where to mount

Bearings should be mounted in a dry, dust-free area away from machines producing swarf and dust. When bearings have to be mounted in an unprotected area, which is often the case with large bearings, steps should be taken to protect the bearing and mounting position from contaminants like dust, dirt and moisture. This can be done by covering or wrapping bearings, machine components etc. with plastic or foil.

Preparations prior to mounting or dismounting

Prior to mounting, be sure all the necessary parts, tools, equipment and data are readily available. It is also advisable to review any drawings or instructions to determine the correct order and direction that components are to be assembled. Leave the bearings in their original packages until immediately prior to mounting so that they are not exposed to any contaminants. If there is a risk that the bearings have become contaminated due to improper handling or damaged packaging, they should be washed and dried prior to mounting.

More information

Mounting, dismounting and bearing care
... → *SKF bearing maintenance handbook*
(ISBN 978-91-978966-4-1)

Mounting instructions for individual bearings → skf.com/mount

Mounting bearings on a tapered seat
..... → skf.com/drive-up

Fig. 1

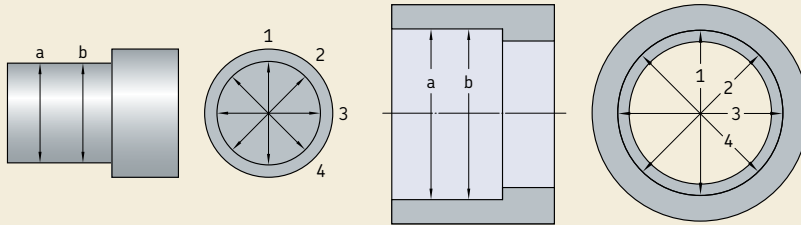

Checking associated components

Housings, shafts, seals and other components of the bearing system should be checked to make sure that they are clean. This is particularly important for threaded holes, lead-ins or grooves where remnants of previous machining operations might have collected. Also, be sure that all unpainted surfaces of cast housings are free of core sand and that any burrs are removed.

When all components have been cleaned and dried, check the dimensional and form tolerances of each piece. The bearings only perform satisfactorily if the associated components comply with the prescribed tolerances. The diameters of cylindrical shaft and housing seats are usually checked with a micrometer or internal gauge at two cross-sections and in four directions (→ fig. 1). Tapered shaft seats can be checked using a ring gauge (GRA 30 series), a taper gauge (DMB or 9205 series) or a sine bar.

It is advisable to keep a record of all measurements. When measuring, it is important that the components and the measuring instruments are approximately the same temperature. This is particularly important for large bearings and their associated components.

Removing the preservative

Normally, the preservative applied to new bearings does not need to be removed. It is only necessary to wipe off the outside and bore surfaces. However, if bearings are to be grease lubricated and used at very high or very low temperatures or if the lubricant to be used is not compatible with the preservative, the bearing should be washed and dried carefully. Bearings capped with seals or shields are filled with grease and should not be washed prior to mounting.

When taken from its original packaging, some large bearings with an outside diameter $D > 420$ mm may be covered with a relatively thick, greasy layer of preservative. These bearings should be washed thoroughly with white mineral spirits or other safe cleaning fluid, and dried.

Bearing handling

SKF recommends using gloves as well as carrying and lifting tools (→ **fig. 2**) that have been specially designed for handling bearings. Using the proper tools enhances safety while saving time and effort.

When handling hot or oily bearings, SKF recommends wearing the appropriate heat or oil resistant gloves.

For large, heavy bearings, lifting tackle that supports the bearing from the bottom should be used (→ **fig. 3**). A spring between the hook and tackle can facilitate positioning the bearing onto the shaft.

To ease lifting, large bearings can be provided, on request, with threaded holes in the ring side faces to accommodate eye bolts. These holes are designed to accommodate only the weight of the bearing, because the size and depth of the hole is limited by the ring thickness. Make sure that the eye bolts are only subjected to load in the direction of the shank axis (→ **fig. 4**).

When mounting a non-split large housing over a bearing that is already in position on a shaft, it is advisable to provide three-point suspension for the housing, and for the length of one sling to be adjustable. This facilitates the process of aligning the housing bore with the bearing outer ring.

Fig. 2

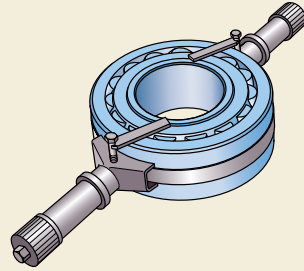

Fig. 3

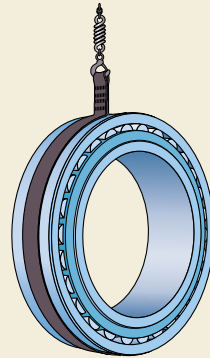
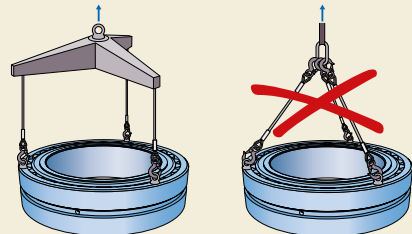

Fig. 4



Mounting

Depending on the bearing type and size, mechanical, thermal or hydraulic methods are used for mounting. In the following, the bearing size is categorized:

- small → $d \leq 80 \text{ mm}$
- medium-size → $80 \text{ mm} < d < 200 \text{ mm}$
- large → $d \geq 200 \text{ mm}$

In all cases, it is important that the bearing rings, cages and rolling elements or seals are never struck directly with any hard object and that the mounting force is never applied through the rolling elements.

For an interference fit, the mating surfaces should be coated with a thin layer of light oil. For a loose fit, the mating surfaces should be coated with SKF anti-fretting agent.

Mounting bearings with a cylindrical bore

With non-separable bearings, the ring that is to have the tighter fit is usually mounted first.

Cold mounting

If the fit is not too tight, small bearings can be driven into position by applying light hammer blows to a sleeve placed against the bearing ring side face. The blows should be evenly distributed around the ring to prevent the bearing from tilting or skewing. The use of a bearing fitting tool (→ fig. 5) or a mounting dolly

(→ fig. 6) instead of a sleeve enables the mounting force to be applied centrally.

Large numbers of bearings are generally mounted with a press.

If a bearing has to be pressed onto the shaft and into the housing bore at the same time, the mounting force must be applied equally to both rings and the abutment surfaces of the mounting tool must lie in the same plane. Whenever possible, mounting should be done with an SKF bearing fitting tool (→ fig. 5).

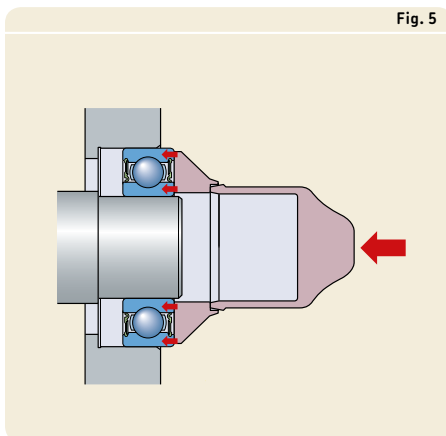

Fig. 5

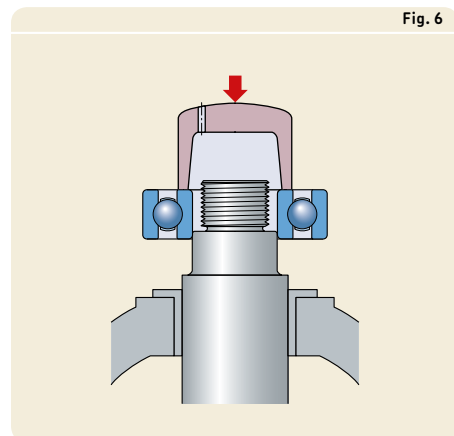

Fig. 6

Mounting, dismounting and bearing care

With self-aligning bearings, the use of an intermediate mounting ring prevents the outer ring from tilting and swiveling when the bearing and shaft assembly is introduced into the housing bore (→ **fig. 7**). The balls of larger self-aligning ball bearings in the 12 and 13 series protrude from the sides of the bearing. This design feature needs to be considered when mounting these bearings.

With separable bearings, the inner ring can be mounted independently of the outer ring, which simplifies mounting, particularly where both rings have an interference fit. When installing the shaft and inner ring assembly into the housing containing the outer ring, careful alignment is required to avoid scoring the raceways and rolling elements. When mounting cylindrical or needle roller bearings with an inner ring without flanges or a flange on one side, a guiding sleeve should be used (→ **fig. 8**). The outside diameter of the sleeve should be the same as the raceway diameter of the inner ring and should be machined to tolerance class d10 (E) for cylindrical roller bearings, and to tolerance 0/-0,025 mm for needle roller bearings.

Hot mounting

It is generally not possible to mount larger bearings without heating either the bearing or the housing, as the force required to mount a bearing increases considerably with increasing bearing size.

The requisite difference in temperature between the bearing ring and shaft or housing depends on the degree of interference and the diameter of the bearing seat. Open bearings must not be heated to more than 120 °C (250 °F). SKF does not recommend heating bearings capped with seals or shields above 80 °C (175 °F). However, if higher temperatures are necessary, make sure that the temperature does not exceed the permissible temperature of either the seal or grease, whichever is lowest.

When heating bearings, local overheating must be avoided. To heat bearings evenly, SKF electric induction heaters (→ **fig. 9**) are recommended. If hotplates are used, the bearing must be turned over a number of times. The seals on sealed bearings should never contact the heating plate directly. Place a ring between the plate and bearing.

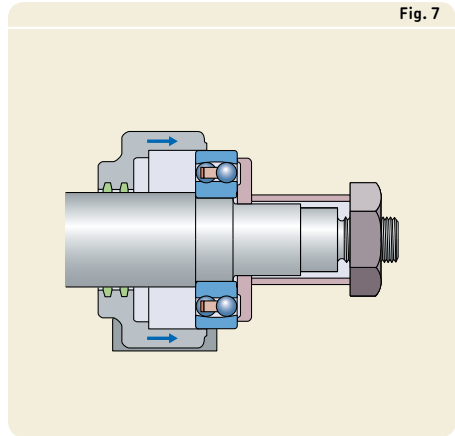

Fig. 7

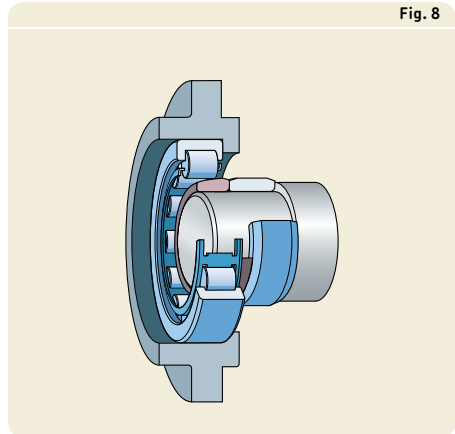

Fig. 8

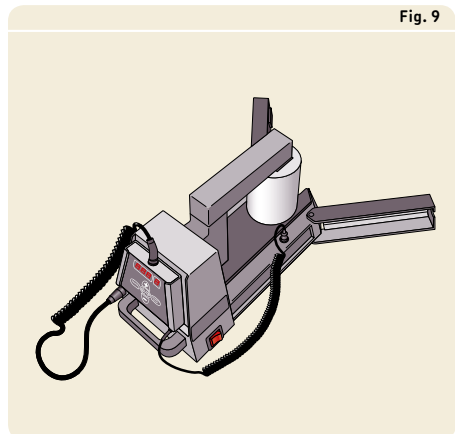

Fig. 9

Bearing adjustment

The internal clearance of single row angular contact ball bearings and single row tapered roller bearings is only established when the bearing is adjusted against a second bearing. Usually, these bearings are arranged in pairs, either back-to-back or face-to-face, and one bearing ring is axially displaced until a given clearance or preload is obtained. For information about bearing preload, refer to *Bearing preload* (→ page 214).

The following recommendations refer only to the adjustment of the internal clearance for bearing arrangements with angular contact ball bearings or tapered roller bearings.

The appropriate value for the clearance to be obtained when mounting, depends on the bearing size and arrangement and operating conditions such as load and temperature. Since there is a definite relationship between the radial and axial internal clearance of angular contact ball bearings and tapered roller bearings, it is sufficient to specify one value, generally the axial internal clearance. This specified value is then obtained, from a condition of zero clearance by loosening or tightening a nut on the shaft or a threaded ring in the housing bore or by inserting calibrated washers or shims between one of the bearing rings and its abutment. The actual method used to adjust and measure the clearance depends largely on the number of bearings to be mounted.

One way to check the axial clearance in a bearing arrangement is to use a dial indicator attached to the hub (→ fig. 10). When adjusting tapered roller bearings and measuring clearance, the shaft or housing should be turned through several revolutions in both directions to be sure that there is proper contact of the roller ends with the guide flange on the inner ring. Without proper contact, the measured result will not be correct.

Fig. 10

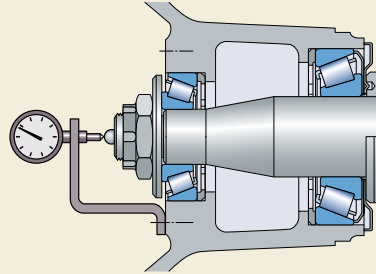

Mounting, dismounting and bearing care

Mounting bearings with a tapered bore

For bearings with a tapered bore, inner rings are always mounted with an interference fit. The degree of interference is determined by how far the bearing is driven up onto a tapered shaft seat or an adapter or withdrawal sleeve. As the bearing is driven up the tapered seat, its radial internal clearance is reduced. This reduction in clearance or the axial drive-up distance can be measured to determine the degree of interference and the proper fit. Recommended values of clearance reduction and axial drive-up are listed in the relevant product chapter.

Small and medium-size bearings

Small and medium-size bearings ($d \leq 120$ mm) can be driven up onto a tapered seat using either a bearing fitting tool or, preferably, a lock nut. For adapter sleeves, use the sleeve nut that can be tightened with a hook or impact spanner. Withdrawal sleeves can be driven into the bearing bore using a bearing fitting tool or an end plate. Starting from a 50 mm thread, SKF hydraulic nuts can also be used.

Medium- and large-size bearings

Because larger bearings ($d > 120$ mm) require considerably more force to mount, SKF hydraulic nuts should be used. Where applicable, SKF also recommends preparing the shaft for the oil injection method prior to mounting. When combining the two methods, bearing installation and removal becomes much faster, easier and safer. For additional information about the oil injection equipment required for both the hydraulic nut and the oil injection method, refer to the information available online at skf.com/mapro.

Mounting with SKF hydraulic nuts

Bearings with a tapered bore can be mounted with the aid of an SKF hydraulic nut:

- on a tapered shaft seat (→ **fig. 11**)
- on an adapter sleeve (→ **fig. 12**)
- on a withdrawal sleeve (→ **fig. 13**)

The hydraulic nut can be positioned onto a threaded section of the shaft (→ **fig. 11**), or onto the thread of a sleeve (→ **figs. 12 and 13**). The annular piston abuts the inner ring of

Fig. 11

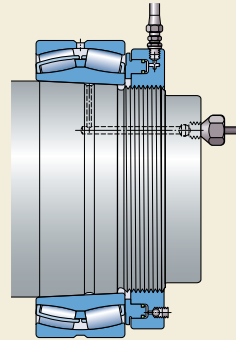

Fig. 12

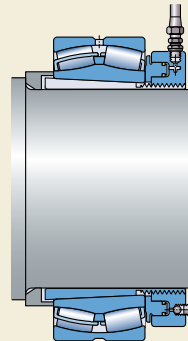

Fig. 13

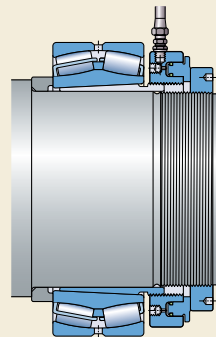
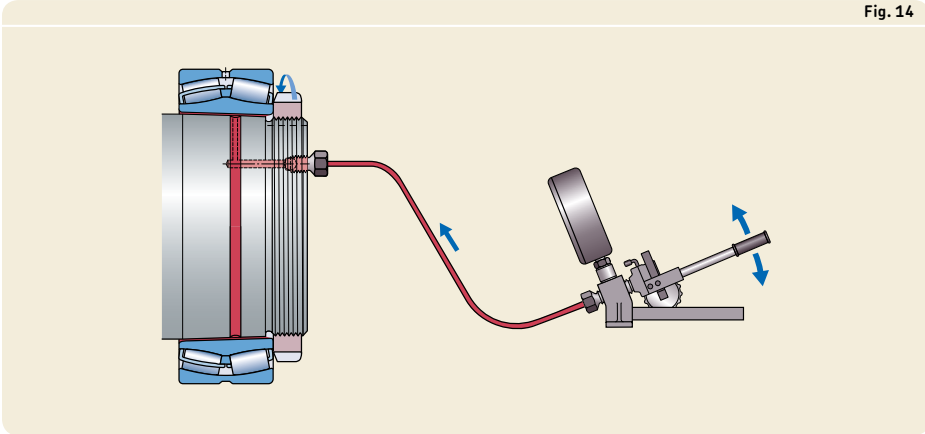

Fig. 14



the bearing (→ **figs. 11 and 12**) or a stop on the shaft, which can be either a nut on a shaft thread (→ **fig. 13**) or a plate attached to the end of the shaft). Pumping oil into the hydraulic nut displaces the piston axially with the force needed for accurate and safe mounting.

Oil injection method

With the oil injection method, oil under high pressure is injected via ducts and distribution grooves between the bearing and bearing seat to form an oil film. This oil film separates the mating surfaces and considerably reduces the friction between them. This method is typically used when mounting bearings directly on tapered shaft seats (→ **fig. 14**). The necessary ducts and grooves should be an integral part of the shaft design. This method can also be used to mount bearings on adapter or withdrawal sleeves if they have been properly prepared.

A spherical roller bearing mounted on a withdrawal sleeve with oil ducts is shown in **fig. 15**. Oil is injected between all mating surfaces so that the withdrawal sleeve can be pressed into the bearing bore as the bolts are tightened.

Fig. 15

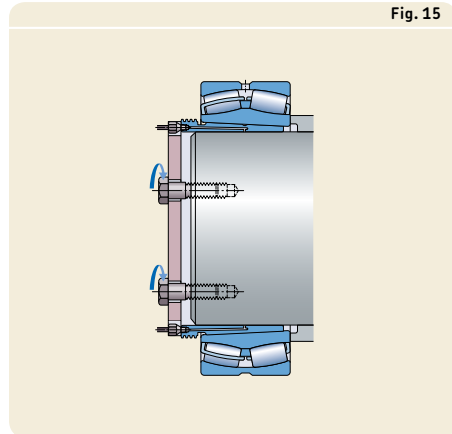

Mounting, dismounting and bearing care

Obtaining an interference fit

During mounting, the degree of interference is normally determined by one of the following methods:

- measuring the clearance reduction
- measuring the lock nut tightening angle
- measuring the axial drive-up
- measuring the inner ring expansion

For self-aligning ball bearings, feeling the clearance reduction by swivelling the outer ring is an additional method (→ **page 548**).

Measuring the clearance reduction

A feeler gauge is most often used to measure the radial internal clearance in medium- and large-size spherical and CARB toroidal roller bearings. Recommended values for the reduction of radial internal clearance to obtain the correct interference fit are listed in the relevant product chapter.

Before mounting, the clearance should be measured between the outer ring and uppermost roller (→ **fig. 16**). After mounting, the clearance should be measured between the inner or outer ring and lowest roller, depending on the bearing internal design (→ **fig. 17**).

Before measuring, the inner or outer ring should be rotated a few times. Both bearing rings and the roller complement must be centrally arranged relative to each other.

For larger bearings, especially those with a thin-walled outer ring, the measurements are affected by the elastic deformation of the rings, caused by the weight of the bearing or the force to draw the feeler gauge blade through the gap between the raceway and an unloaded roller. To establish the “true” clearance before and after mounting, use the following procedure (→ **fig. 18**):

Fig. 16

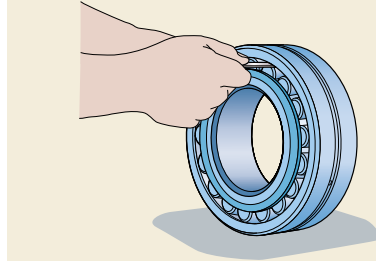

Fig. 17

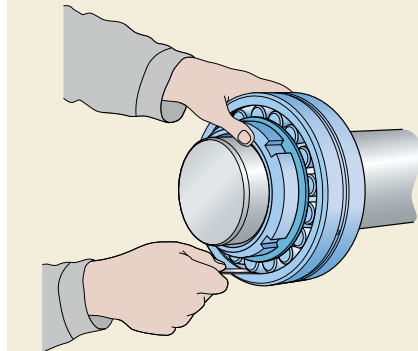

Fig. 18

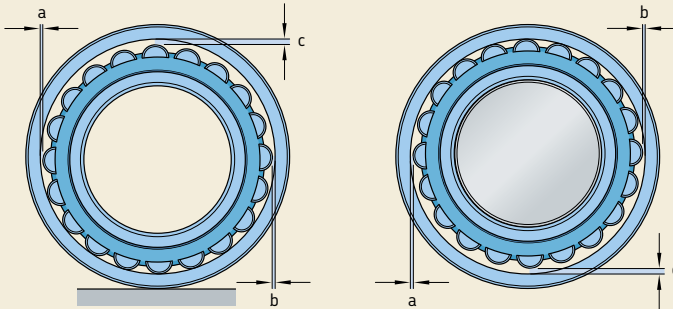
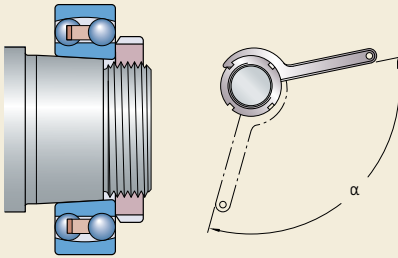

Fig. 19



- 1 Measure the clearance "c" at the 12 o'clock position for a standing bearing or at the 6 o'clock position for an unmounted bearing hanging from the shaft.
- 2 Measure the clearance "a" at the 9 o'clock position and "b" at the 3 o'clock position without moving the bearing.
- 3 Obtain the "true" radial internal clearance with relatively good accuracy from $0,5(a + b + c)$.

Measuring the lock nut tightening angle

This method can be used for mounting small to medium-size bearings with a tapered bore ($d \leq 120$ mm). Recommended values for the tightening angle α are listed in the relevant product chapter.

Before starting the final tightening procedure, the bearing should be pushed up on the tapered seat until it is firmly in position. By tightening the nut through the recommended angle α (→ **fig. 19**), the bearing is driven up over the proper distance on the tapered seat. The bearing inner ring then has the requisite interference fit. The residual clearance should be checked whenever possible.

H

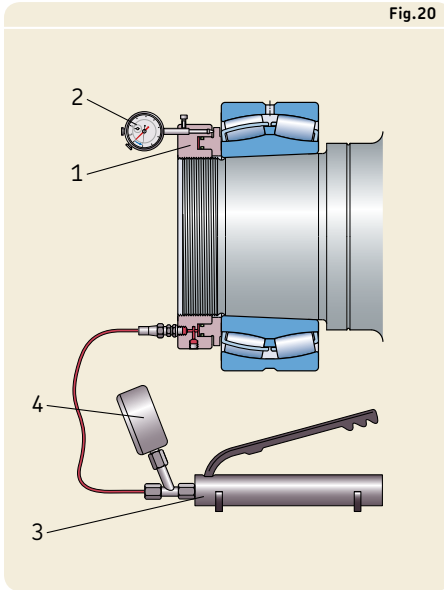

Fig. 20

Measuring the axial drive-up

Mounting bearings with a tapered bore can be done by measuring the axial drive-up of the inner ring on its seat. Recommended values for the required axial drive-up are listed in the relevant product chapter.

However, the SKF Drive-up Method is recommended for medium- and large-size bearings. This method provides a reliable and easy way to determine the degree of interference. The correct fit is achieved by controlling the axial displacement of the bearing from a predetermined position. This method incorporates the use of an SKF hydraulic nut (1) fitted with a dial indicator (2), and a hydraulic pump (3) fitted with a pressure gauge (4), appropriate to the mounting conditions (→ fig. 20).

The SKF Drive-up Method is based on a two stage mounting procedure (→ fig. 21):

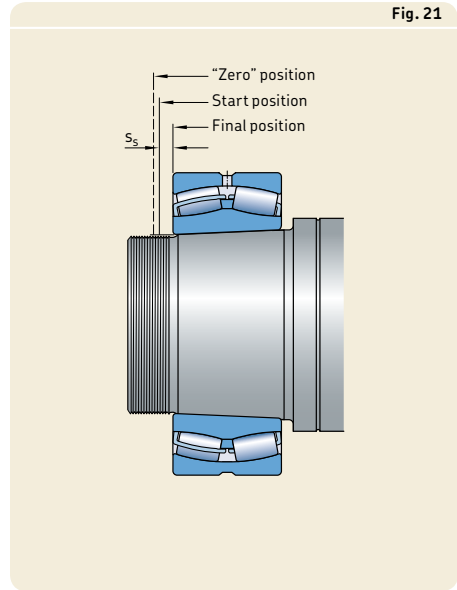
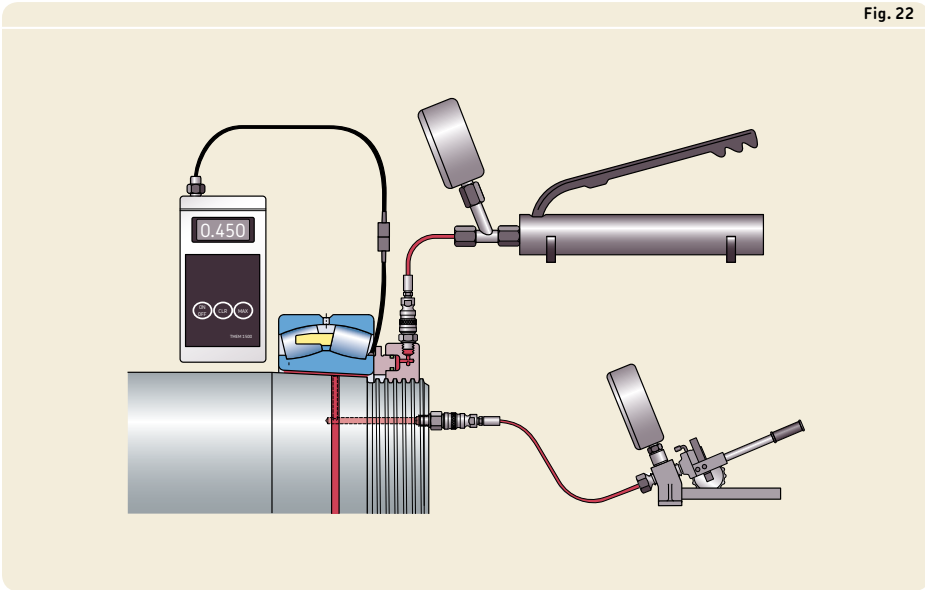

Fig. 21

- Stage one
By applying a predetermined pressure in the hydraulic nut, the bearing is pushed from the "zero" position to a reliable start position.
- Stage two
By increasing the pressure in the hydraulic nut, the bearing inner ring is pushed further on its tapered seat to the final position. The displacement s_s is measured by the dial indicator.

Recommended values for the requisite oil pressure to reach the start position and the axial displacement to reach the final position for individual bearings are available online at skf.com/mount or skf.com/drive-up.

Fig. 22



Measuring the inner ring expansion

Measuring the inner ring expansion is a quick and accurate method to determine the correct position of large spherical and CARB toroidal roller bearings on their seats ($d \geq 340$ mm, depending on the series). To apply this method, use common hydraulic mounting tools and SensorMount, which comprises a bearing with a sensor imbedded in the inner ring and a dedicated hand-held indicator (→ fig. 22). Aspects like bearing size, shaft material and design (solid or hollow), and surface finish do not need any special consideration.

For additional information about SensorMount, contact the SKF application engineering service.

Test running

Once assembly is complete, an application should undergo a test run to determine that all components are operating properly. During a test run, the application should run under partial load and – where there is a wide speed range – at slow or moderate speeds. A rolling bearing should never be started up unloaded and then accelerated to high speed, as there is a risk that the rolling elements slide and damage the raceways, or that the cage is subjected to impermissible stresses. A minimum bearing load needs to be applied (refer to *Minimum load* in the relevant product chapter).

Any noise or vibration can be checked using an SKF electronic stethoscope. Normally, bearings produce an even “purring” noise. Whistling or screeching indicates inadequate lubrication. An uneven rumbling or hammering is in most cases due to the presence of contaminants in the bearing or to bearing damage caused during mounting.

An increase in bearing temperature immediately after start-up is normal. In the case of grease lubrication, the temperature does not drop until the grease has been evenly distributed in the bearing arrangement, after which an equilibrium temperature is reached. Unusually high temperatures or constant peaking indicate that there is too much lubricant in the arrangement or that the bearing is radially or axially distorted. Other causes could be that associated components have not been made or mounted correctly, or that the seals are generating too much heat.

During the test run, or immediately afterwards, check the seals, any lubrication systems and all fluid levels. If noise and vibration levels are severe, it is advisable to check the lubricant for signs of contamination.

Machines on standby

Machines on standby should be rotated or run as frequently as possible to redistribute the lubricant within the bearings and change the position of the rolling elements relative to the raceways.

Fig. 23

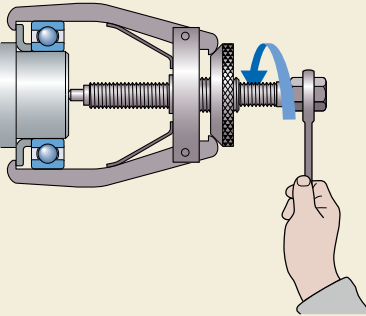

Fig. 24

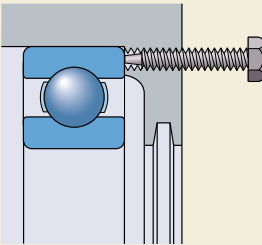
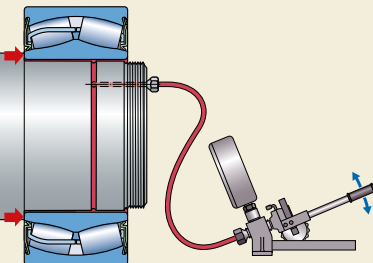

Fig. 25



Dismounting

If bearings are to be used again after removal, the force used to dismount them must never be applied through the rolling elements.

With separable bearings, the ring with the rolling element and cage assembly can be removed independently of the other ring. With non-separable bearings, the ring having the looser fit should be withdrawn from its seat first. To dismount a bearing with an interference fit, the tools described in the following section can be used. The choice of tools depends on the bearing type, size and fit. In the following, the bearing size is categorized:

- small → $d \leq 80 \text{ mm}$
- medium-size → $80 \text{ mm} < d < 200 \text{ mm}$
- large → $d \geq 200 \text{ mm}$

Dismounting bearings fitted on a cylindrical shaft seat

Cold dismounting

Small bearings can be removed from a shaft by applying light hammer blows via a suitable drift to the ring side face, or preferably by using a mechanical puller. The claws must be applied to the inner ring or an adjacent component (→ fig. 23). Dismounting is made easier if slots for the claws of a puller are provided in the shaft and/or housing shoulders. Alternatively, tapped holes in the housing shoulder can be provided to accommodate withdrawal screws (→ fig. 24).

Medium- and large-size bearings generally require greater force than a mechanical tool can provide. Therefore, SKF recommends using either hydraulically assisted tools or the oil injection method, or both. This presupposes that the necessary oil supply ducts and distribution grooves have been designed into the shaft arrangement (→ fig. 25).

Mounting, dismounting and bearing care

Hot dismounting

Dismounting with heat is a suitable method when removing inner rings of needle roller bearings or NU, NJ and NUP design cylindrical roller bearings. Two different tools for this purpose are common: heating rings and adjustable induction heaters.

Heating rings are typically used to mount and dismount the inner ring of small to medium-size bearings that are all the same size. Heating rings are made of light alloy. They are radially slotted and equipped with insulated handles (→ **fig. 26**).

If inner rings with different diameters are dismounted frequently, SKF recommends using an adjustable induction heater. These heaters (→ **fig. 27**) heat the inner ring rapidly without heating the shaft.

Special fixed induction heaters have been developed to dismount the inner rings of large cylindrical roller bearings (→ **fig. 28**).

Induction heaters and heating rings are available from SKF. For additional information, visit skf.com/mapro.

Fig. 26

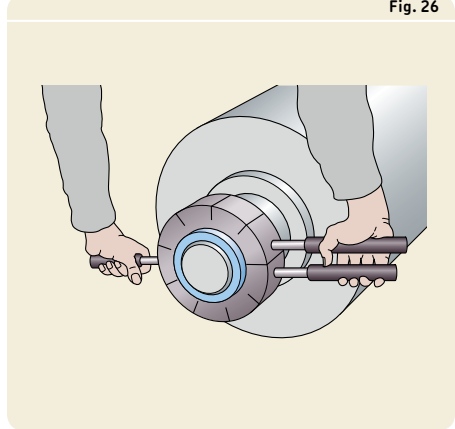

Fig. 27

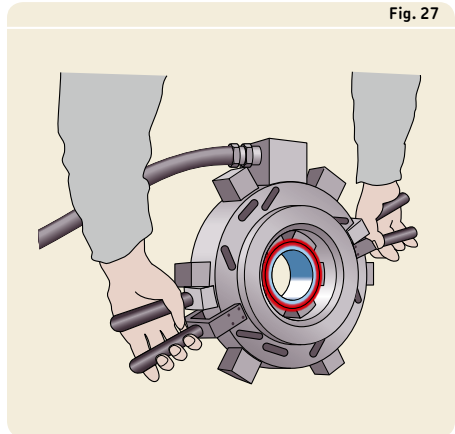
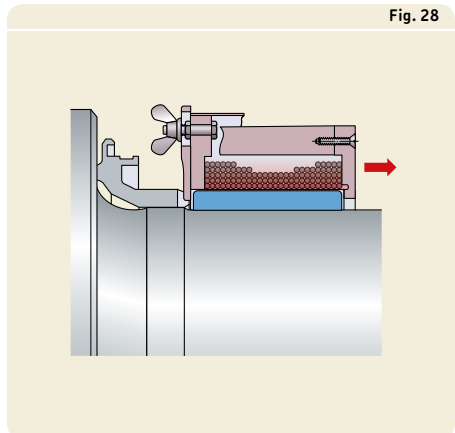

Fig. 28



Dismounting bearings fitted on a tapered shaft seat

Small bearings can be dismounted using a mechanical or hydraulically assisted puller that engages the inner ring. Self-centring pullers equipped with spring-operated arms should be used to simplify the procedure and avoid damage to the bearing seat. If it is not possible to apply the claws of the puller to the inner ring, withdraw the bearing via the outer ring or use a puller in combination with a pulling plate (→ **fig. 29**).

Dismounting medium- and large-size bearings is easier and much safer when the oil injection method is used. This method injects oil, under high pressure, between the two tapered mating surfaces, via a supply duct and a distribution groove. This significantly reduces the friction between the two surfaces and produces an axial force that separates the bearing from its seat (→ **fig. 30**).

Fig. 29

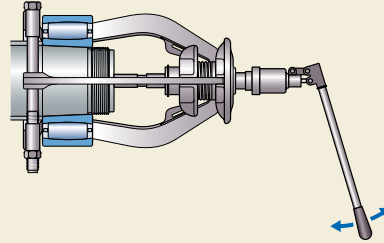
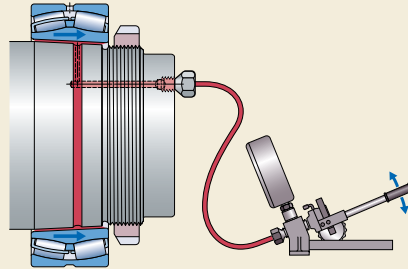

Fig. 30



WARNING

To avoid the risk of serious injury, attach a provision such as a lock nut to the shaft end to limit bearing travel when the bearing suddenly comes loose.

Dismounting bearings fitted on an adapter sleeve

Small bearings fitted on an adapter sleeve and a plain shaft can be dismounted by tapping a small steel block with an appropriate hammer evenly around the bearing inner ring side face (→ **fig. 31**). Before doing so, the sleeve lock nut has to be loosened a few turns.

Small bearings fitted on an adapter sleeve and a stepped shaft can be dismounted by a couple of sharp hammer blows applied to a dolly abutting the sleeve lock nut (→ **fig. 32**). Before doing so, the sleeve lock nut has to be loosened a few turns.

Using a hydraulic nut for dismounting bearings fitted on an adapter sleeve and a stepped shaft makes bearing removal easy. To use this method however, it must be possible to mount a suitable stop that abuts to the piston of the hydraulic nut (→ **fig. 33**). If the sleeves are provided with oil supply ducts and distribution grooves, dismounting becomes easier because the oil injection method can be used.

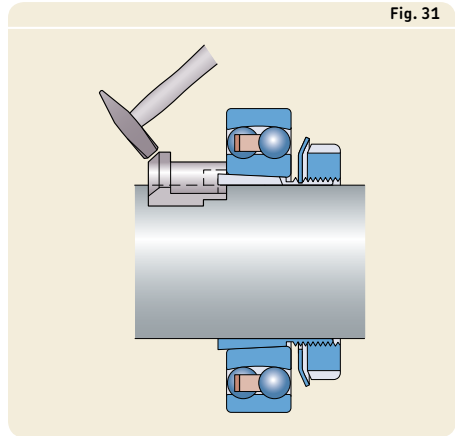

Fig. 32

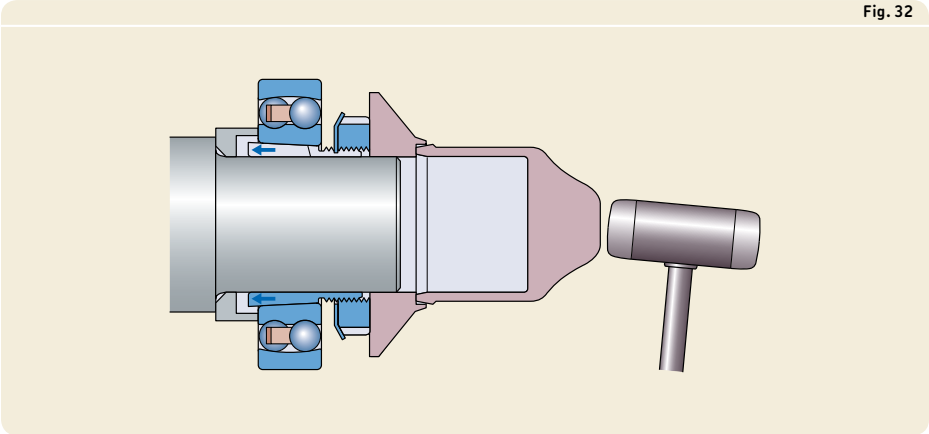
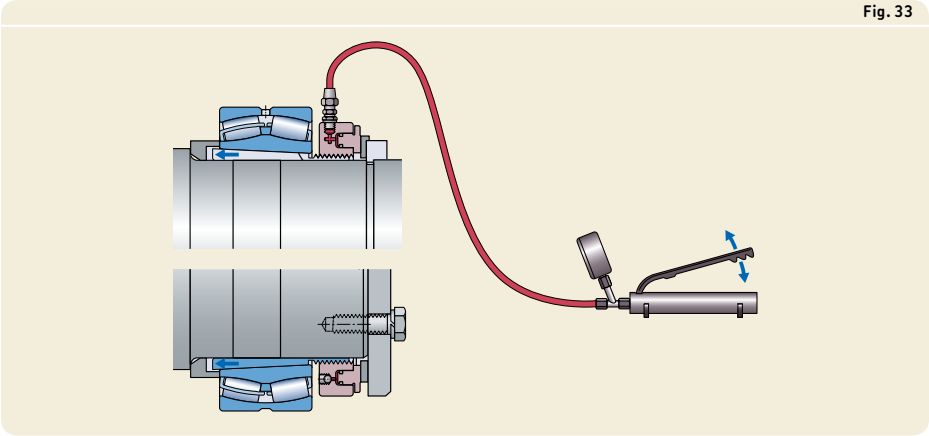

Fig. 33



Dismounting bearings fitted on a withdrawal sleeve

When dismounting a bearing fitted on a withdrawal sleeve, the locking device (e.g. lock nut, end plate etc.) has to be removed.

Small and medium-size bearings can be dismounted with a lock nut and a hook or impact spanner (→ **fig. 34**).

Medium- and large-size bearings fitted on a withdrawal sleeve can be easily dismounted with a hydraulic nut. SKF strongly recommends providing a stop behind the hydraulic nut at the shaft end (→ **fig. 35**). The stop prevents the withdrawal sleeve and hydraulic nut from shooting off the shaft if the sleeve separates suddenly from its seat.

Withdrawal sleeves with a bore diameter ≥ 200 mm are provided, as standard, with two oil supply ducts and distribution grooves in both the bore and outside surface. When using the oil injection method, two hydraulic pumps or oil injectors and appropriate extension pipes are needed (→ **fig. 36**).

Fig. 34

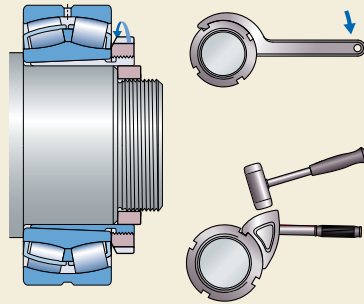

Fig. 35

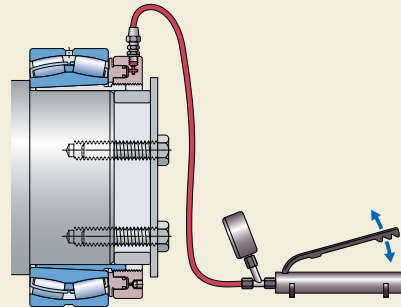
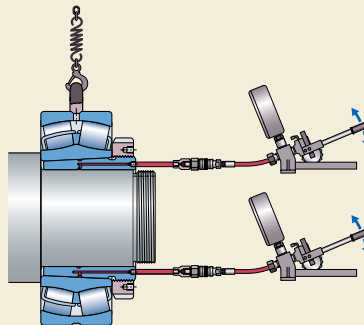

Fig. 36



Bearing storage

The conditions under which bearings, seals and lubricants are stored can have an adverse effect on their performance. Inventory control can also play an important role in performance, particularly if seals and lubricants are involved. Therefore, SKF recommends a “first in, first out” inventory policy.

Storage conditions

To maximize the service life of bearings, SKF recommends the following basic housekeeping practices:

- Store bearings flat, in a vibration-free, dry area with a cool, steady temperature.
- Control and limit the relative humidity of the storage area as follows:
 - 75% at 20 °C (68 °F)
 - 60% at 22 °C (72 °F)
 - 50% at 25 °C (77 °F)
- Keep bearings in their original unopened packages until immediately prior to mounting to prevent the ingress of contaminants and corrosion.
- Bearings that are not stored in their original packaging should be well protected against corrosion and contaminants.

Shelf life of open bearings

SKF bearings are coated with a rust-inhibiting compound and suitably packaged before distribution. For open bearings, the preservative provides protection against corrosion for approximately five years, provided the storage conditions are appropriate.

Shelf life of capped bearings

The maximum storage interval for capped SKF bearings is dictated by the lubricant inside the bearings. Lubricant deteriorates over time as a result of ageing, condensation, and separation of the oil and thickener. Therefore, capped bearings should not be stored for more than three years.

Inspection and cleaning

As with all other important machine components, rolling bearings must be cleaned and inspected frequently. The intervals between these inspections depend entirely on the operating conditions.

If it is possible to ascertain the condition of a bearing during service, by using condition monitoring equipment, listening to the bearing with a stethoscope, monitoring temperature or lubricant analysis, then it is usually sufficient to clean and inspect all components annually. Where loads are heavy, the frequency of inspection should be increased.

After the bearing components have been cleaned with a suitable solvent such as white mineral spirits, they should be oiled or greased immediately to prevent corrosion. This is particularly important for bearings in machines that are left to stand for extended periods.

Product data

Deep groove ball bearings	1	
Y-bearings (insert bearings)	2	
Angular contact ball bearings	3	
Self-aligning ball bearings	4	
Cylindrical roller bearings	5	
Needle roller bearings	6	
Tapered roller bearings	7	
Spherical roller bearings	8	
CARB toroidal roller bearing	9	
Thrust ball bearings	10	
Cylindrical roller thrust bearings	11	
Needle roller thrust bearings	12	
Spherical roller thrust bearings	13	
Track runner bearings	14	
Engineered products	15	
Bearing accessories	16	





1 Deep groove ball bearings

Designs and variants	296	Product tables	
Single row deep groove ball bearings ..	296	1.1 Single row deep groove ball bearings	322
Stainless steel		1.2 Capped single row deep groove ball bearings	346
deep groove ball bearings	296	1.3 ICOS oil sealed bearing units	374
Single row deep groove ball bearings with filling slots.	297	1.4 Single row deep groove ball bearings with a snap ring groove.	376
Double row deep groove ball bearings.	298	1.5 Single row deep groove ball bearings with a snap ring and shields	382
Cages.	298	1.6 Stainless steel deep groove ball bearings	386
Sealing solutions	300	1.7 Capped stainless steel deep groove ball bearings.	394
Shields.	301	1.8 Single row deep groove ball bearings with filling slots.	410
Non-contact seals	301	1.9 Single row deep groove ball bearings with filling slots and a snap ring.	414
Low-friction seals.	302	1.10 Double row deep groove ball bearings	416
Contact seals.	303		
ICOS oil sealed bearing units	304	Other deep groove ball bearings	
Greases for capped bearings	304	Sensor bearing units	1151
Grease life for capped bearings	306	Bearings for extreme temperatures	1169
Bearings with a snap ring groove	308	Bearings with Solid Oil	1185
Quiet running bearings.	309	SKF DryLube bearings	1191
Matched bearings.	309	INSOCOAT bearings	1205
		Hybrid bearings	1219
		NoWear coated bearings	1241
		Polymer ball bearings	1247
Performance classes	310		
SKF Explorer bearings	310		
SKF Energy Efficient (E2) bearings	310		
Bearing data	313		
(Dimension standards, tolerances, internal clearance, misalignment, friction, starting torque, power loss, defect frequencies)			
Loads	317		
(Minimum load, axial load carrying capacity, equivalent loads)			
Temperature limits.	318		
Permissible speed.	318		
Designation system	320		

1 Deep groove ball bearings

Designs and variants

Deep groove ball bearings are particularly versatile. They are simple in design, non-separable, suitable for high and very high speeds and are robust in operation, requiring little maintenance. Because deep groove ball bearings are the most widely used bearing type, they are available from SKF in many designs, variants and sizes.

In addition to the bearings presented in this chapter, deep groove ball bearings for special applications are shown under *Engineered products*. Deep groove ball bearings for special applications include:

- sensor bearing units (→ **page 1151**)
- bearings for extreme temperatures (→ **page 1169**)
- bearings with Solid Oil (→ **page 1185**)
- SKF DryLube bearings (→ **page 1191**)
- INSOCOAT bearings (→ **page 1205**)
- hybrid bearings (→ **page 1219**)
- NoWear coated bearings (→ **page 1241**)
- polymer ball bearings (→ **page 1247**)

More information

Bearing life and load ratings	63
Design considerations	159
Bearing systems	160
Recommended fits	169
Abutment and fillet dimensions	208
Lubrication	239
Mounting, dismantling and bearing care	271
Mounting instructions for individual bearings	→ skf.com/mount

Fig. 1

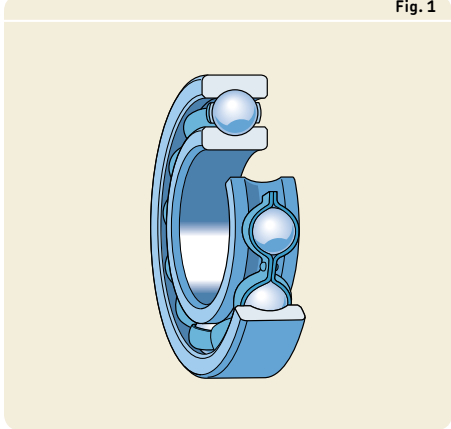

Single row deep groove ball bearings

SKF single row deep groove ball bearings (→ **fig. 1**) have deep, uninterrupted raceway grooves. These raceway grooves have a close osculation with the balls, enabling the bearings to accommodate radial loads and axial loads in both directions.

Single row deep groove ball bearings are available open or capped (with seals or shields). Open bearings that are also available capped, may have recesses in the outer ring (→ **fig. 2**).

Inch single row deep groove ball bearings and bearings with a tapered bore are not presented in this catalogue. For information about inch single row deep groove ball bearings, refer to the product information available online at skf.com/bearings. For additional information about deep groove ball bearings with a tapered bore, contact the SKF application engineering service.

Stainless steel deep groove ball bearings

SKF stainless steel deep groove ball bearings (→ **fig. 1**) are corrosion resistant when exposed to moisture and several other media. They can accommodate radial loads and axial loads in both directions. These bearings have a lower load carrying capacity than same-sized bearings made of high chromium steel.

The bearings are available open or capped (with seals or shields). Open bearings that are also available capped, may have recesses in

both the inner and outer rings or only in the outer ring (→ **fig. 2**).

Flanged stainless steel deep groove ball bearings and inch bearings are not presented in this catalogue. For information about these bearings, refer to the product information available online at skf.com/bearings.

Single row deep groove ball bearings with filling slots

Single row deep groove ball bearings with filling slots have a filling slot in both the inner and outer rings (→ **fig. 3**) to accommodate more balls than standard deep groove ball bearings. Filling slot bearings have a higher radial load carrying capacity than bearings without filling slots, but their axial load carrying capacity is limited. They are also unable to operate at the same high speeds as bearings without filling slots.

Deep groove ball bearings with filling slots are available open or with shields. They are also available with or without a snap ring groove. Open bearings that are also available with shields, may have recesses in the outer ring (→ **fig. 4**).

Fig. 3

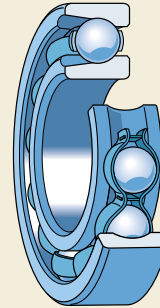

Fig. 2

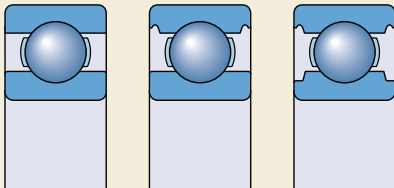
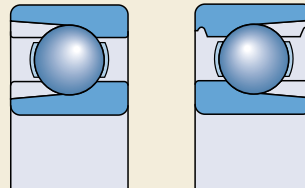

Fig. 4



1 Deep groove ball bearings

Double row deep groove ball bearings

SKF double row deep groove ball bearings (→ **fig. 5**) correspond in design to single row deep groove ball bearings. Their deep, uninterrupted raceway grooves have a close osculation with the balls, enabling the bearings to accommodate radial loads and axial loads in both directions.

Double row deep groove ball bearings are very suitable for bearing arrangements where the load carrying capacity of a single row bearing is inadequate. For the same bore and outside diameter, double row bearings are slightly wider than single row bearings in the 62 and 63 series, but have a considerably higher load carrying capacity.

Double row deep groove ball bearings are only available as open bearings (without seals or shields).

Cages

Depending on their design, series and size, SKF deep groove ball bearings are fitted with one of the cages shown in **table 1**. Double row bearings are equipped with two cages. The standard stamped steel cage is not identified in the bearing designation. If non-standard cages are required, check availability prior to ordering.

The lubricants generally used for rolling bearings do not have a detrimental effect on cage properties. However, some synthetic oils and greases with a synthetic oil base and lubricants containing a high proportion of EP additives, when used at high temperatures, can have a detrimental effect on polyamide cages. For additional information about the suitability of cages, refer to *Cages* (→ **page 37**) and *Cage materials* (→ **page 152**).

Fig. 5

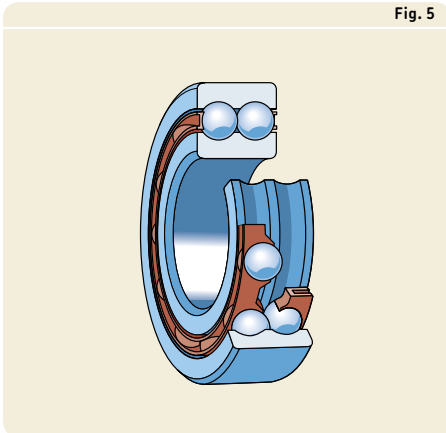

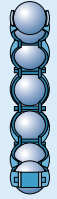

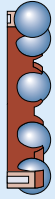

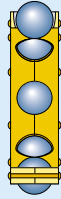

Table 1

Cages for deep groove ball bearings							
	Steel cages			Polymer cages			Brass cages
		 					
		a b					
Cage type	Ribbon-type, ball centred	Riveted, ball centred	Snap-type, ball centred	Snap-type, ball centred			Riveted, ball, outer ring or inner ring centred
Material	Stamped steel			PA66, glass fibre reinforced	PA46, glass fibre reinforced	PEEK, glass fibre reinforced	Machined brass
Suffix	–	–	–	TN9	VG1561	TNH	M, MA or MB
Single row bearings	Standard	Standard (a)	–	Check availability	Standard for SKF E2 bearings, check availability for other bearings	Check availability	Standard
Stainless steel bearings	Standard, stainless steel	Standard (a), stainless steel	Standard, stainless steel	Check availability	–	–	–
Single row bearings with filling slots	–	Standard (b)	–	–	–	–	–
Double row bearings	–	–	–	Standard	–	–	–

1 Deep groove ball bearings

Sealing solutions

SKF supplies the most popular sizes of deep groove ball bearings capped with a seal or shield on one or both sides. Selection guidelines for different sealing solutions under various operating conditions are listed in **table 2**. However, these guidelines cannot substitute for testing a seal in its application. For additional information, refer to *Sealing solutions* (→ **page 226**).

ICOS oil sealed bearing units, which are standard deep groove ball bearings with an integrated radial shaft seal, are also available.

When capped bearings must operate under certain extreme conditions, such as very high speeds or high temperatures, grease may leak at the inner ring. For bearing arrangements where this would be detrimental, special design steps must be undertaken. For additional information, contact the SKF application engineering service.

Bearings capped on both sides are lubricated for the life of the bearing and should not be washed or relubricated. They are filled with the appropriate amount of a high-quality grease under clean conditions. The bearings are considered maintenance-free. If they are to be hot mounted, an induction heater should be used.

SKF does not recommend heating capped bearings above 80 °C (175 °F). However, if higher temperatures are necessary, make sure that the temperature does not exceed the permissible temperature of either the seal or grease, whichever is lowest.

The seals, which are fitted in a recess on the outer ring, make good, positive contact with the recess, without deforming the outer ring (→ **figs. 7 to 9, pages 301 to 303**).

Table 2

Selection guidelines for SKF sealing solutions

Requirement	Shields	Non-contact seals	Low-friction seals	Contact seals	
	Z, ZS	RZ	RSL	RSH	RS1
Low friction	+++	+++	++	○	○
High speed	+++	+++	+++	○	○
Grease retention	○	+	+++	+++	++
Dust exclusion	○	+	++	+++	+++
Water exclusion					
static	–	–	○	+++	++
dynamic	–	–	○	+	+
high pressure	–	–	○	+++	○

Symbols: +++ = best ++ = very good + = good ○ = fair – = not recommended

Shields

Bearings with shields are primarily intended for applications where the inner ring rotates. Shields are fitted in the outer ring and do not make contact with the inner ring, but form a narrow gap with it. Shields are made of sheet steel. For stainless steel bearings, stainless steel is used.

Depending on the bearing design, series and size, SKF supplies shields in different designs. Shields identified by the designation suffix Z typically have an extension in the shield bore to form a long, narrow gap with the inner ring shoulder (→ **fig. 6a**). Some shields do not have the extension (→ **fig. 6b**). The bore of a Z shield on some stainless steel deep groove ball bearings can extend into a recess on the inner ring (→ **fig. 6c**).

Shields identified by the designation suffix ZS are available for stainless steel bearings only. These shields are fixed in the outer ring by a retaining ring (→ **fig. 6d**) and may extend into a recess on the inner ring.

Non-contact seals

Bearings with non-contact seals can be operated at the same speeds as bearings with shields, but with improved sealing effectiveness. The seals form an extremely narrow gap with the inner ring shoulder (→ **fig. 7**). Non-contact seals are made of oil and wear-resistant NBR that is reinforced by a sheet steel insert.

SKF deep groove ball bearings with a non-contact seal on one or both sides are identified

by the designation suffix RZ or 2RZ. Non-contact seals are available for single row deep groove ball bearings only.

Some stainless steel bearings are available with non-contact seals on request. The exact seal design may differ from the illustration (→ **fig. 7**).

Fig. 7



RZ

Fig. 6

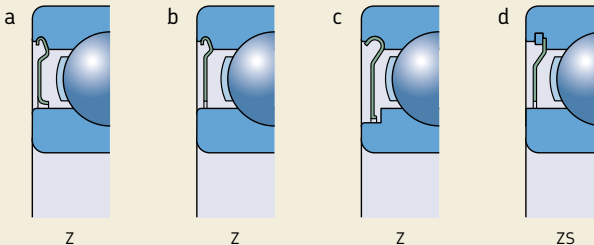

Z

Z

Z

ZS

1 Deep groove ball bearings

Low-friction seals

Bearings with low-friction seals can accommodate the same speeds as bearings with shields, but with improved sealing effectiveness. The seals are practically non-contacting with a recess in the inner ring shoulder.

Single row deep groove ball bearings with a low-friction seal on one or both sides are identified by the designation suffix RSL or 2RSL. The seals are made of oil and wear-resistant NBR that is reinforced with a sheet steel insert.

Low-friction seals are available for bearings in the 60, 62 and 63 series. They are manufactured in two designs depending on bearing size (→ **fig. 8**).

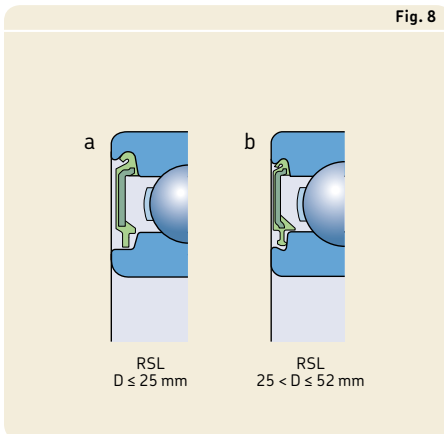

Contact seals

Contact seals (→ **fig. 9**) are made of oil and wear-resistant NBR or FKM and are reinforced with a sheet steel insert.

SKF deep groove ball bearings with a contact seal made of NBR on one or both sides are manufactured in five designs depending on the bearing:

- Bearings in the 60, 62, and 63 series are equipped with RSH seals to design **(a)** when $D \leq 25$ mm.
- Bearings in the 60, 62 and 63 series are equipped with RSH seals to design **(b)** when $25 \text{ mm} < D \leq 52$ mm.
- Other bearings have RS1 seals, which seal against the inner ring shoulder **(c)** or against a recess in the inner ring side face **(d)**. The difference is indicated by dimension d_1 or d_2 in the product tables.
- Stainless steel bearings are equipped with RS1 seals to design **(c)** or **(e)**. The exact seal design may differ from the illustrations.

Bearings with seals made of FKM are available on request. They are identified by the designation suffix RS2 or 2RS2.

WARNING

Seals made of FKM (fluoro rubber) exposed to an open flame or temperatures above $300 \text{ }^\circ\text{C}$ ($570 \text{ }^\circ\text{F}$) are a health and environmental hazard! They remain dangerous even after they have cooled.

Read and follow the safety precautions under *Seal materials* (→ **page 155**).

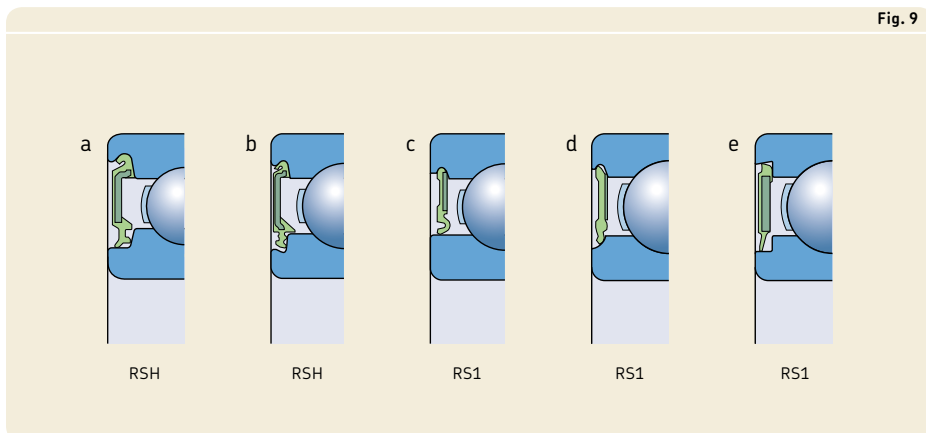

1 Deep groove ball bearings

ICOS oil sealed bearing units

ICOS oil sealed bearing units are designed for applications where sealing requirements exceed the capabilities of bearings with contact seals. An ICOS unit consists of a 62 series deep groove ball bearing and one integral SKF WAVE seal (→ **fig. 10**). The SKF WAVE seal is a single lip, spring loaded radial shaft seal made of NBR. ICOS units need less axial space than an arrangement using a bearing and an external seal. They simplify mounting and avoid expensive machining of the shaft because the inner ring shoulder is the seal counterface.

The limiting speeds quoted in the product table are based on the permissible circumferential speed for the seal, which is 14 m/s.

Greases for capped bearings

Depending on the design, series and size, bearings capped on both sides are filled with one of the following standard greases:

- basic design deep groove ball bearings → **table 3**
- SKF Energy Efficient deep groove ball bearings → low-friction grease GE2
- stainless steel deep groove ball bearings → LHT23
- deep groove ball bearings with filling slots → GJN.

Fig. 10

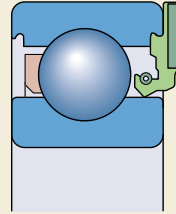

On request, bearings can be supplied with the following special greases:

- high temperature grease GJN when $D \leq 62$ mm
- wide temperature range grease HT or WT
- wide temperature range and silent running grease LHT23 (for bearings where it is not standard)
- low temperature grease LT
- non-toxic grease (designation suffix VT378) for stainless steel deep groove ball bearings

This grease fulfils the requirements of the "Guidelines of section 21 CFR 178.3570" of the FDA (US Food and Drug Administration) regulations and is approved by the USDA (United States Department of Agriculture) for category H1 use (lubricants with incidental food contact).

Table 3

SKF standard greases for capped single row deep groove ball bearings made of carbon chromium steel

Bearings in diameter series	SKF standard greases in bearings with outside diameter			
	$D \leq 30$ mm $d < 10$ mm	$d \geq 10$ mm	$30 < D \leq 62$ mm	$D > 62$ mm
8, 9	LHT23	LT10	MT47	MT33
0, 1, 2, 3	MT47	MT47	MT47	MT33

The technical specifications of the various greases are listed in **table 4**. The standard grease is not identified in the bearing designation (no designation suffix). Special greases are indicated by the corresponding grease suffix. Check availability of bearings with special grease prior to ordering.

Table 4

Technical specifications of SKF standard and special greases for capped deep groove ball bearings

Grease	Temperature range ¹⁾							Thickener	Base oil type	NLGI consistency class	Base oil viscosity [mm ² /s]		Grease performance factor (GPF)
	-50	0	50	100	150	200	250				at 40 °C (105 °F)	at 100 °C (210 °F)	
MT33								Lithium soap	Mineral	3	100	10	1
MT47								Lithium soap	Mineral	2	70	7,3	1
LT10								Lithium soap	Diester	2	12	3,3	2
LHT23								Lithium soap	Ester	2-3	27	5,1	2
LT								Lithium soap	Diester	2	15	3,7	1
WT								Polyurea soap	Ester	2-3	70	9,4	4
GJN								Polyurea soap	Mineral	2	115	12,2	2
HT								Polyurea soap	Mineral	2-3	98	10,5	2
VT378								Aluminium complex soap	PAO	2	150	15,5	-
GE2								Lithium soap	Synthetic	2	25	4,9	-

¹⁾ Refer to the SKF traffic light concept → page 244

1 Deep groove ball bearings

Grease life for capped bearings

Grease life for capped bearings should be estimated according to the procedure described in this section. The grease life for capped bearings is presented as L_{10} , i.e. the time period at the end of which 90% of the bearings are still reliably lubricated. The method to estimate relubrication intervals (→ *Relubrication intervals*, page 252) represents the L_{01} grease life and should not be used.

The grease life for capped bearings depends on the operating temperature and the speed factor. It can be obtained from the diagrams.

Diagram 1 is valid for standard deep groove ball bearings. The grease performance factor (GPF) is listed in **table 4** (→ page 305).

Diagram 2 is valid for SKF Energy Efficient deep groove ball bearings.

The grease life for each is valid under the following operating conditions:

- horizontal shaft
- inner ring rotation
- light load ($P \leq 0,05 C$)
- operating temperature within the green temperature zone of the grease (→ **table 4, page 305**)
- stationary machine
- low vibration levels

For stainless steel bearings filled with VT378 grease, use the scale corresponding to $GPF = 1$ and multiply the value obtained from the diagram by 0,2.

Diagram 1

Grease life for capped deep groove ball bearings
where $P = 0,05 C$

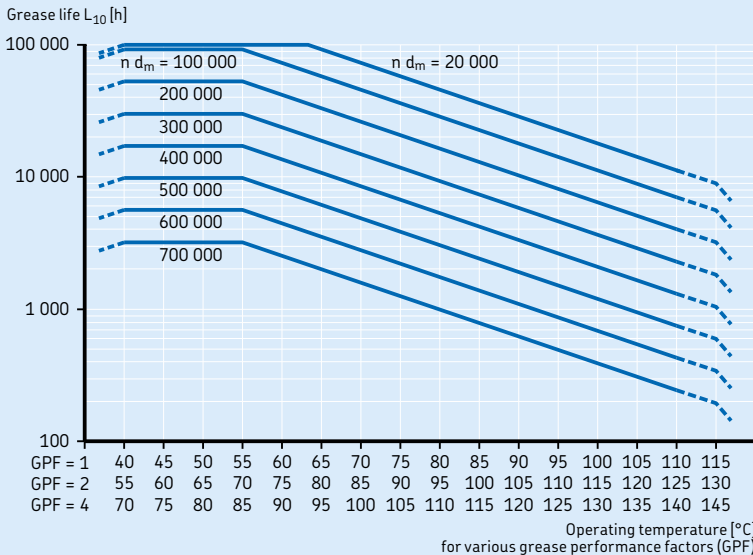

n = rotational speed [r/min]
 d_m = bearing mean diameter [mm]
 $= 0,5 (d + D)$

If the operating conditions differ, the grease life obtained from the diagrams has to be adjusted:

- For vertical shafts, use 50% of the value from the diagram.
- For heavier loads ($P > 0,05 C$), use the reduction factor listed in **table 5**.

Table 5

Reduction factor for the grease life, depending on the load

Load P	Reduction factor
$\leq 0,05 C$	1
0,1 C	0,7
0,125 C	0,5
0,25 C	0,2

Diagram 2

Grease life for SKF Energy Efficient deep groove ball bearings
where $P = 0,05 C$

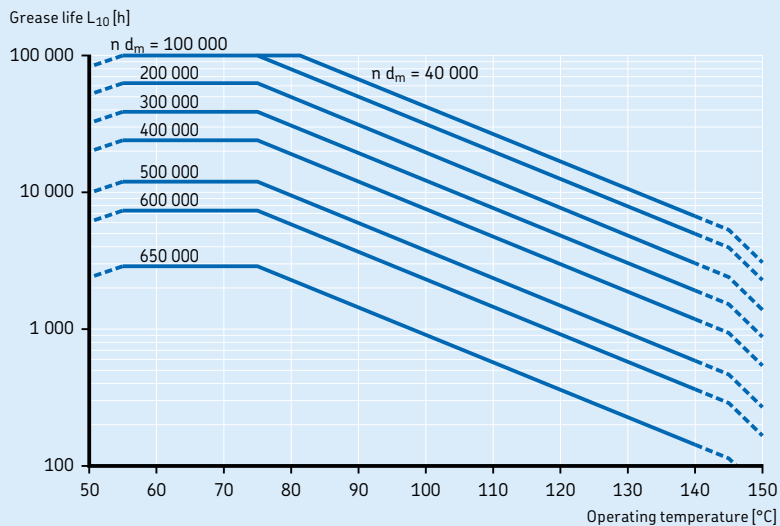

n = rotational speed [r/min]
 d_m = bearing mean diameter [mm]
 $= 0,5 (d + D)$

1 Deep groove ball bearings

Bearings with a snap ring groove

Deep groove ball bearings with a snap ring groove can simplify the design of an arrangement because the bearings can be located axially in the housing by a snap ring (→ **fig. 11**). This saves space and can significantly reduce installation time. Appropriate snap rings are shown in the product tables with their designation and dimensions. They can be supplied separately or fitted to the bearing.

The following variants (→ **fig. 12**) are available for basic design deep groove ball bearings and for bearings with filling slots:

- open bearings with a snap ring groove only (designation suffix N)
- open bearings with a snap ring (designation suffix NR)
- bearings with a snap ring and a shield on the opposite side (designation suffix ZNR)
- bearings with a snap ring and a shield on both sides (designation suffix 2ZNR)

For bearings with filling slots, the snap ring groove is on the same side as the filling slots.

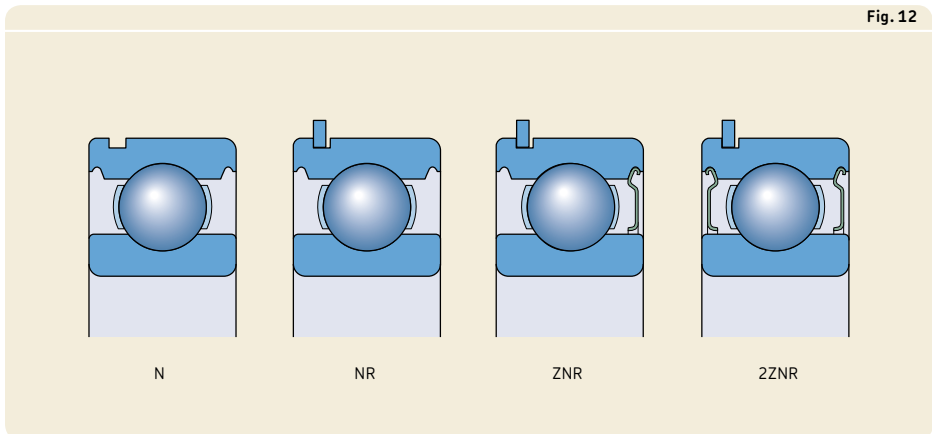
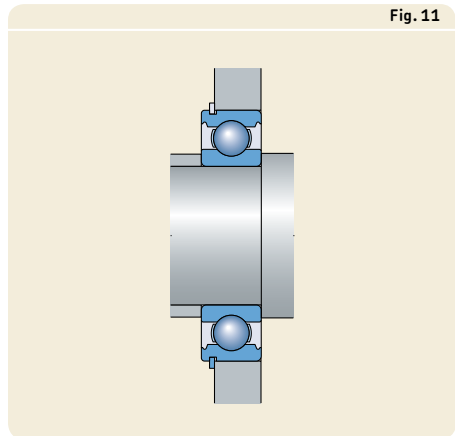

Quiet running bearings

SKF Quiet Running deep groove ball bearings are designed to comply with stringent noise requirements in applications such as wind turbine generators and to provide consistent performance over a variety of operating conditions. These bearings are identified by the designation suffix VQ658. The range covers bearing sizes typically used in wind turbine generators. For additional information, contact the SKF application engineering service.

Matched bearings

For bearing arrangements where the load carrying capacity of a single bearing is inadequate, or where the shaft has to be located axially in both directions with a specific axial clearance, SKF can supply matched pairs of single row deep groove ball bearings on request. Depending on the requirements, the matched pairs can be supplied in tandem, back-to-back, or face-to-face arrangements (→ fig. 13). The bearings are matched in production so that, when mounted immediately adjacent to each other, the load is evenly distributed between the bearings without having to use shims or similar devices.

For additional information about matched bearings, refer to the product information available online at skf.com/bearings.

Fig. 13

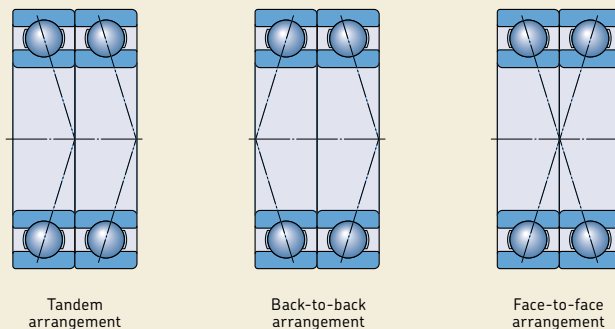

1 Deep groove ball bearings

Performance classes

SKF Explorer bearings

In response to the ever-demanding performance requirements of modern machinery, SKF developed the SKF Explorer performance class of rolling bearings.

SKF Explorer deep groove ball bearings realized this substantial improvement in performance by optimizing the internal geometry and surface finish of all contact surfaces, redesigning the cage, combining the extremely clean and homogenous steel with a unique heat treatment and improving the quality and consistency of the balls.

SKF Explorer deep groove ball bearings provide superior performance especially in applications like electric motors, two-wheelers and transmissions. These improvements provide the following benefits:

- higher dynamic load carrying capacity
- reduced noise and vibration levels
- less frictional heat
- significantly extended bearing service life

These bearings reduce environmental impact by enabling downsizing and reducing both lubricant and energy use. Just as importantly, SKF Explorer bearings can reduce the need for maintenance and contribute to increased productivity.

SKF Explorer bearings are shown with an asterisk in the product tables. The bearings retain the designation of earlier standard bearings. However, each bearing and its box are marked with the name “SKF EXPLORER”.

SKF Energy Efficient (E2) bearings

To meet the ever-increasing demand to reduce friction and energy use, SKF has developed the SKF Energy Efficient (E2) performance class of rolling bearings. SKF E2 deep groove ball bearings are characterized by a frictional moment in the bearing that is at least 30% lower when compared to a same-sized SKF Explorer bearing.

The bearings realized the substantial reduction of the frictional moment by optimizing the internal geometry of the bearing, redesigning the cage and applying a new, low-friction grease.

SKF E2 deep groove ball bearings have been shown to last longer and consume less lubricant than comparable SKF Explorer deep groove ball bearings. The enhanced performance characteristics require the following conditions:

- speed $n > 1\,000$ r/min
- load $P \leq 0,125 C$

If conditions vary, contact the SKF application engineering service.

Typical applications include electric motors, pumps, conveyors and fans.

SKF E2 deep groove ball bearings are available in the 60, 62 and 63 series. They are supplied with a shield on both sides and have C3 radial internal clearance as standard.

Bearing data

	Single row deep groove ball bearings
Dimension standards	Boundary dimensions: ISO 15 Snap rings and grooves: ISO 464
Tolerances	Normal P6 or P5 on request
For additional information (→ page 132)	<p>SKF Explorer and SKF E2 bearings</p> <p>Dimensional accuracy to P6 and reduced width tolerance:</p> <p>D ≤ 110 mm → 0/−60 μm D > 110 mm → 0/−100 μm</p>
	<p>Running accuracy</p> <p>D ≤ 52 mm → P5 52 mm < D ≤ 110 mm → P6 D > 110 mm → Normal tolerances</p>
	Values: ISO 492, (→ tables 3 to 5, pages 137 to 139)
Internal clearance	Normal Check availability of C2, C3, C4, C5, reduced ranges of standard clearance classes or partitions of adjacent classes
For additional information (→ page 149)	<p>SKF E2 bearings</p> <p>C3 Check availability of other clearance classes</p>
	Values: ISO 5753-1, (→ table 6, page 314), except for stainless steel ...
Misalignment	≈ 2 to 10 minutes of arc
	The permissible angular misalignment between the inner and outer rings depends on the size and internal design of the bearing, the radial internal clearance in operation and the forces and moments acting on the ...
Friction, starting torque, power loss	Frictional moment, starting torque, and power loss can be calculated as specified under <i>Friction</i> (→ page 97), or using the tools ...
Defect frequencies	Defect frequencies can be calculated using the tools ...

Stainless steel deep groove ball bearings	Single row deep groove ball bearings with filling slots	Double row deep groove ball bearings
Boundary dimensions: ISO 15, except for bearings with suffix X	Boundary dimensions : ISO 15 Snap rings and grooves: ISO 464	Boundary dimensions: ISO 15
Normal Other classes on request	Normal	Normal
Normal Check availability of other clearance classes d < 10 mm (→ table 7, page 315)	Normal	Normal Check availability of C3 clearance class
... bearings with d < 10 mm. Values are valid for unmounted bearings under zero measuring load.		
≈ 2 to 10 minutes of arc	≈ 2 to 5 minutes of arc	≤ 2 minutes of arc
... bearing. As a result, only approximate values are listed here. Any misalignment increases bearing noise and reduces bearing service life.		
... available online at skf.com/bearingcalculator .		
... available online at skf.com/bearingcalculator .		

1 Deep groove ball bearings

Table 6

Radial internal clearance of deep groove ball bearings

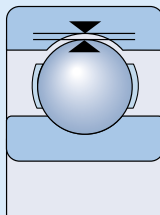

Bore diameter		Radial internal clearance									
d		C2		Normal		C3		C4		C5	
over	incl.	min.	max.	min.	max.	min.	max.	min.	max.	min.	max.
mm		µm									
2,5	6	0	7	2	13	8	23	-	-	-	-
6	10	0	7	2	13	8	23	14	29	20	37
10	18	0	9	3	18	11	25	18	33	25	45
18	24	0	10	5	20	13	28	20	36	28	48
24	30	1	11	5	20	13	28	23	41	30	53
30	40	1	11	6	20	15	33	28	46	40	64
40	50	1	11	6	23	18	36	30	51	45	73
50	65	1	15	8	28	23	43	38	61	55	90
65	80	1	15	10	30	25	51	46	71	65	105
80	100	1	18	12	36	30	58	53	84	75	120
100	120	2	20	15	41	36	66	61	97	90	140
120	140	2	23	18	48	41	81	71	114	105	160
140	160	2	23	18	53	46	91	81	130	120	180
160	180	2	25	20	61	53	102	91	147	135	200
180	200	2	30	25	71	63	117	107	163	150	230
200	225	2	35	25	85	75	140	125	195	175	265
225	250	2	40	30	95	85	160	145	225	205	300
250	280	2	45	35	105	90	170	155	245	225	340
280	315	2	55	40	115	100	190	175	270	245	370
315	355	3	60	45	125	110	210	195	300	275	410
355	400	3	70	55	145	130	240	225	340	315	460
400	450	3	80	60	170	150	270	250	380	350	520
450	500	3	90	70	190	170	300	280	420	390	570
500	560	10	100	80	210	190	330	310	470	440	630
560	630	10	110	90	230	210	360	340	520	490	700
630	710	20	130	110	260	240	400	380	570	540	780
710	800	20	140	120	290	270	450	430	630	600	860
800	900	20	160	140	320	300	500	480	700	670	960
900	1 000	20	170	150	350	330	550	530	770	740	1 040
1 000	1 120	20	180	160	380	360	600	580	850	820	1 150
1 120	1 250	20	190	170	410	390	650	630	920	890	1 260
1 250	1 400	30	200	190	440	420	700	680	1 000	-	-
1 400	1 600	30	210	210	470	450	750	730	1 060	-	-

Table 7

Radial internal clearance of stainless steel deep groove ball bearings with a bore diameter < 10 mm

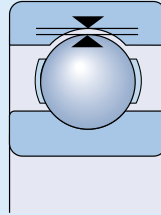

Bore diameter d	over incl.	Radial internal clearance				Normal		C3		C4		C5		
		C1 min.	max.	C2 min.	max.	min.	max.	min.	max.	min.	max.	min.	max.	
mm		μm												
–		9,525	0	5	3	8	5	10	8	13	13	20	20	28

Table 8

Calculation factors for deep groove ball bearings

$f_0 F_a/C_0$	Single row and double row bearings Normal clearance			Single row bearings C3 clearance			C4 clearance		
	e	X	Y	e	X	Y	e	X	Y
0,172	0,19	0,56	2,3	0,29	0,46	1,88	0,38	0,44	1,47
0,345	0,22	0,56	1,99	0,32	0,46	1,71	0,4	0,44	1,4
0,689	0,26	0,56	1,71	0,36	0,46	1,52	0,43	0,44	1,3
1,03	0,28	0,56	1,55	0,38	0,46	1,41	0,46	0,44	1,23
1,38	0,3	0,56	1,45	0,4	0,46	1,34	0,47	0,44	1,19
2,07	0,34	0,56	1,31	0,44	0,46	1,23	0,5	0,44	1,12
3,45	0,38	0,56	1,15	0,49	0,46	1,1	0,55	0,44	1,02
5,17	0,42	0,56	1,04	0,54	0,46	1,01	0,56	0,44	1
6,89	0,44	0,56	1	0,54	0,46	1	0,56	0,44	1

Calculation factors must be selected according to the operating clearance in the bearing, which may differ from the internal clearance before mounting. For additional information or for calculation factors for other clearance classes, contact the SKF application engineering service.

Intermediate values can be obtained by linear interpolation.

1 Deep groove ball bearings

Loads

	Single row deep groove ball bearings	Stainless steel deep groove ball bearings
Minimum load For additional information (→ page 86)	$F_{rm} = k_r \left(\frac{v n}{1\,000} \right)^{2/3} \left(\frac{d_m}{100} \right)^2$ <p>The weight of the components supported by the bearing, together with external forces, generally exceed the requisite minimum load. If this is not the case, the bearing must be subjected to an additional radial load. For applications where single row or stainless steel deep groove ball bearings are used, ...</p>	
Axial load carrying capacity	Pure axial load → $F_a \leq 0,5 C_0$ Small bearings ¹⁾ and light series bearings ²⁾ → $F_a \leq 0,25 C_0$	Pure axial load → $F_a \leq 0,25 C_0$
	Excessive axial load can lead to a considerable reduction in bearing service life.	
Equivalent dynamic bearing load For additional information (→ page 85)	$F_a/F_r \leq e \rightarrow P = F_r$ $F_a/F_r > e \rightarrow P = X F_r + Y F_a$	
Equivalent static bearing load For additional information (→ page 88)	$P_0 = 0,6 F_r + 0,5 F_a$ $P_0 < F_r \rightarrow P_0 = F_r$	

¹⁾ $d \leq 12$ mm

²⁾ Diameter series 8, 9, 0, and 1

Single row deep groove ball bearings with filling slots	Double row deep groove ball bearings	Symbols
<p>... an axial preload can be applied by adjusting the inner and outer rings against each other, or by using springs.</p>		<p>C_0 = basic static load rating [kN] (→ product tables) d_m = bearing mean diameter [mm] $= 0,5 (d + D)$ e = limit for the load ratio depending on the relationship $f_0 F_a/C_0$ (→ table 8, page 315) f_0 = calculation factor (→ product tables) F_a = axial load [kN] F_r = radial load [kN] F_{rm} = minimum radial load [kN] k_r = minimum load factor (→ product tables) n = rotational speed [r/min] P = equivalent dynamic bearing load [kN] P_0 = equivalent static bearing load [kN] X = calculation factor for the radial load (→ table 8, page 315) Y = calculation factor for the axial load depending on the relationship $f_0 F_a/C_0$ (→ table 8, page 315) ν = actual operating viscosity of the lubricant [mm²/s]</p>
$F_a \leq 0,6 F_r$	Pure axial load $\rightarrow F_a \leq 0,5 C_0$	
$F_a/F_r \leq 0,6$ and $P \leq 0,5 C_0$ $\rightarrow P = F_r + F_a$	$F_a/F_r \leq e \rightarrow P = F_r$ $F_a/F_r > e \rightarrow P = X F_r + Y F_a$	
$F_a/F_r \leq 0,6$ $\rightarrow P_0 = F_r + 0,5 F_a$	$P_0 = 0,6 F_r + 0,5 F_a$ $P_0 < F_r \rightarrow P_0 = F_r$	

1 Deep groove ball bearings

Temperature limits

The permissible operating temperature for deep groove ball bearings can be limited by:

- the dimensional stability of the bearing rings and balls
- the cage
- the seals
- the lubricant

When temperatures outside the permissible range are expected, contact the SKF application engineering service.

Bearing rings and balls

SKF deep groove ball bearings undergo a special heat treatment. The bearings are heat stabilized up to at least 120 °C (250 °F).

Cages

Steel or brass cages can be used at the same operating temperatures as the bearing rings and balls. For temperature limits of polymer cages, refer to *Cage materials* (→ page 152).

Seals

The permissible operating temperature for seals depends on the material:

- NBR seals:
–40 to +100 °C (–40 to +210 °F)
Temperatures up to 120 °C (250 °F) can be tolerated for brief periods.
- FKM seals:
–30 to +230 °C (–20 to +445 °F)

Lubricants

Temperature limits for greases used in SKF deep groove ball bearings capped on both sides are provided in **table 4** (→ page 305). Temperature limits for other SKF greases are provided under *Lubrication* (→ page 239).

When using lubricants not supplied by SKF, the temperature limits should be evaluated according to the SKF traffic light concept (→ page 244).

Permissible speed

The permissible speed can be estimated using the speed ratings listed in the product tables and applying the information provided under *Speeds* (→ page 117). If no reference speed is listed in the product tables, the limiting speed is the permissible speed.

SKF recommends oil lubrication for bearings with a ring centred cage (designation suffix MA or MB). When these bearings are grease lubricated (→ *Lubrication*, page 239) the speed factor is limited to $A \leq 450\,000 \text{ mm/min}$.

where

$$A = n d_m [\text{mm/min}]$$

$$d_m = \text{bearing mean diameter [mm]} \\ = 0,5 (d + D)$$

$$n = \text{rotational speed [r/min]}$$

For applications exceeding these values, contact the SKF application engineering service.

Matched bearings

For matched bearings, the permissible speed calculated for a single bearing should be reduced to approximately 80% of the quoted value.

Permissible speed

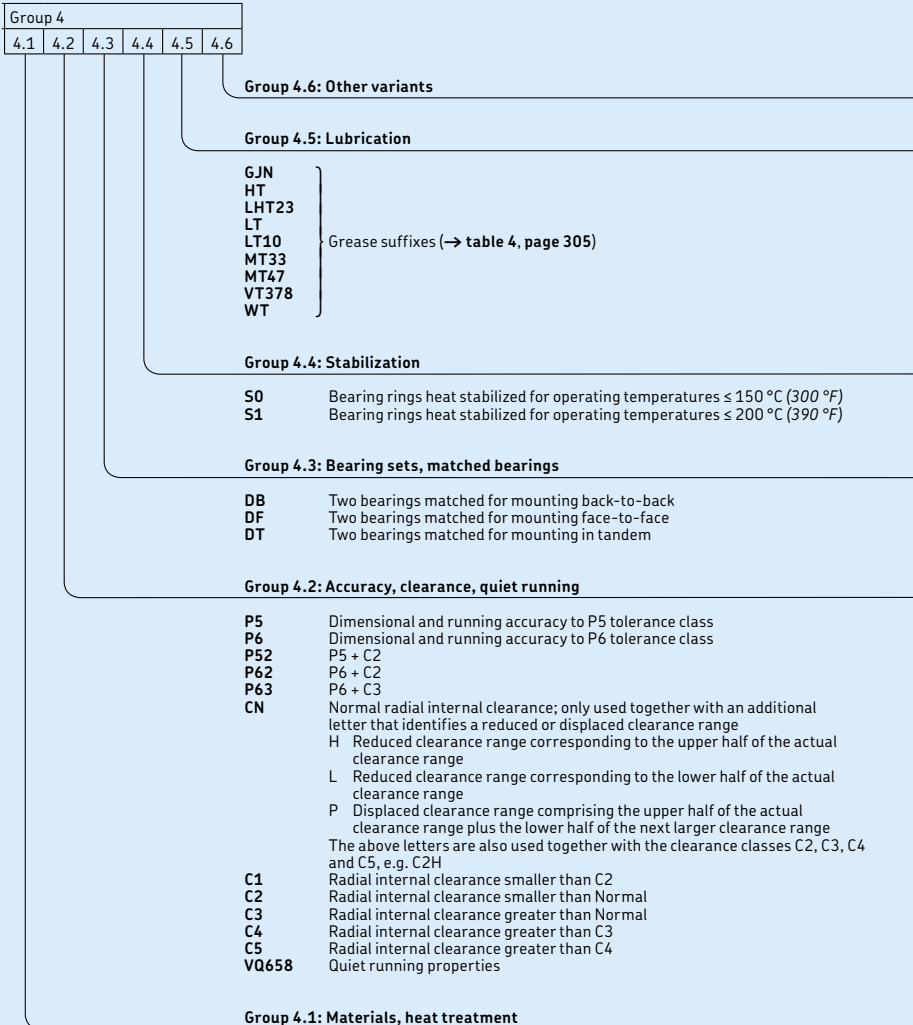

1.1 Single row deep groove ball bearings d 3 – 10 mm

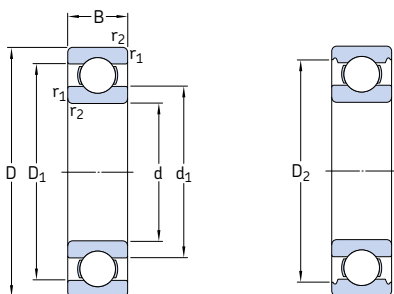

Principal dimensions			Basic load ratings		Fatigue load limit	Speed ratings		Mass	Designation
d	D	B	dynamic	static		Reference speed	Limiting speed		
mm			C	C ₀	P _u	r/min		kg	–
3	10	4	0,54	0,18	0,007	130 000	80 000	0,0015	623
4	9	2,5	0,423	0,116	0,005	140 000	85 000	0,0007	618/4
	11	4	0,624	0,18	0,008	130 000	80 000	0,0017	619/4
	12	4	0,806	0,28	0,012	120 000	75 000	0,0021	604
	13	5	0,936	0,29	0,012	110 000	67 000	0,0031	624
5	16	5	1,11	0,38	0,016	95 000	60 000	0,0054	634
	11	3	0,468	0,143	0,006	120 000	75 000	0,0012	618/5
	13	4	0,884	0,335	0,014	110 000	70 000	0,0025	619/5
	16	5	1,14	0,38	0,016	95 000	60 000	0,005	* 625
6	19	6	2,34	0,95	0,04	80 000	50 000	0,0085	* 635
	13	3,5	0,715	0,224	0,01	110 000	67 000	0,002	618/6
	15	5	0,884	0,27	0,011	100 000	63 000	0,0039	619/6
7	19	6	2,34	0,95	0,04	80 000	50 000	0,0081	* 626
	14	3,5	0,78	0,26	0,011	100 000	63 000	0,0022	618/7
	17	5	1,06	0,375	0,016	90 000	56 000	0,0049	619/7
	19	6	2,34	0,95	0,04	85 000	53 000	0,0076	* 607
8	22	7	3,45	1,37	0,057	70 000	45 000	0,012	* 627
	16	4	0,819	0,3	0,012	90 000	56 000	0,003	618/8
	19	6	1,46	0,465	0,02	85 000	53 000	0,0071	619/8
	22	7	3,45	1,37	0,057	75 000	48 000	0,012	* 608
9	24	8	3,9	1,66	0,071	63 000	40 000	0,018	* 628
	17	4	0,871	0,34	0,014	85 000	53 000	0,0034	618/9
	20	6	2,34	0,98	0,043	80 000	50 000	0,0076	619/9
	24	7	3,9	1,66	0,071	70 000	43 000	0,014	* 609
10	26	8	4,75	1,96	0,083	60 000	38 000	0,02	* 629
	19	5	1,72	0,83	0,036	80 000	48 000	0,0053	61800
	22	6	2,7	1,27	0,054	70 000	45 000	0,01	61900
	26	8	4,75	1,96	0,083	67 000	40 000	0,019	* 6000
	28	8	5,07	2,36	0,1	60 000	38 000	0,024	16100
	30	9	5,4	2,36	0,1	56 000	36 000	0,031	* 6200
35	11	8,52	3,4	0,143	50 000	32 000	0,053	* 6300	

* SKF Explorer bearing

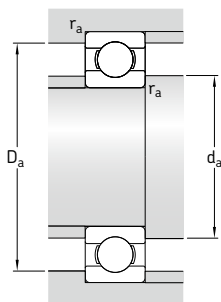

Dimensions					Abutment and fillet dimensions			Calculation factors	
d	d ₁ ~	D ₁ ~	D ₂ ~	r _{1,2} min.	d _a min.	D _a max.	r _a max.	k _r	f ₀
mm					mm			-	
3	5,2	7,5	8,2	0,15	4,2	8,8	0,1	0,025	7,5
4	5,2	7,5	-	0,1	4,6	8,4	0,1	0,015	6,5
	6,1	9	9,9	0,15	4,8	10,2	0,1	0,02	6,4
	6,1	9,9	-	0,2	5,4	10,6	0,2	0,025	10
	6,7	10,3	11,2	0,2	5,8	11,2	0,2	0,025	10
	8,4	12	13,3	0,3	6,4	13,6	0,3	0,03	8,4
5	6,8	9,2	-	0,15	5,8	10,2	0,1	0,015	7,1
	7,5	10,5	11,2	0,2	6,4	11,6	0,2	0,02	11
	8,4	12	13,3	0,3	7,4	13,6	0,3	0,025	8,4
	11,1	15,2	16,5	0,3	7,4	16,6	0,3	0,03	13
6	8	11	-	0,15	6,8	12,2	0,1	0,015	7
	8,2	11,7	13	0,2	7,4	13,6	0,2	0,02	6,8
	11,1	15,2	16,5	0,3	8,4	16,6	0,3	0,025	13
7	9	12	-	0,15	7,8	13,2	0,1	0,015	7,2
	10,4	13,6	14,3	0,3	9	15	0,3	0,02	7,3
	11,1	15,2	16,5	0,3	9	17	0,3	0,025	13
	12,1	17,6	19,2	0,3	9,4	19,6	0,3	0,025	12
8	10,5	13,5	-	0,2	9,4	14,6	0,2	0,015	7,5
	10,5	15,5	16,7	0,3	10	17	0,3	0,02	6,6
	12,1	17,6	19,2	0,3	10	20	0,3	0,025	12
	14,4	19,8	21,2	0,3	10,4	21,6	0,3	0,025	13
9	11,5	14,5	-	0,2	10,4	15,6	0,2	0,015	7,7
	11,6	16,2	17,5	0,3	11	18	0,3	0,02	12
	14,4	19,8	21,2	0,3	11	22	0,3	0,025	13
	14,8	21,2	22,6	0,3	11,4	23,6	0,3	0,025	12
10	12,7	16,3	-	0,3	12	17	0,3	0,015	15
	13,9	18,2	-	0,3	12	20	0,3	0,02	14
	14,8	21,2	22,6	0,3	12	24	0,3	0,025	12
	17	23,2	24,8	0,3	14,2	23,8	0,3	0,025	13
	17	23,2	24,8	0,6	14,2	25,8	0,6	0,025	13
	17,5	26,9	28,7	0,6	14,2	30,8	0,6	0,03	11

1.1 Single row deep groove ball bearings d 12 – 22 mm

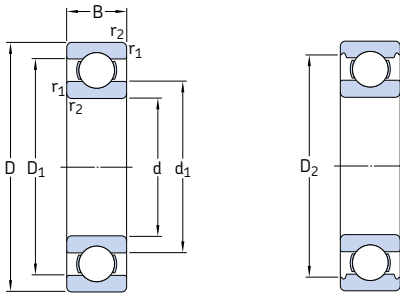

Principal dimensions			Basic load ratings		Fatigue load limit P_u	Speed ratings		Mass	Designation
d	D	B	C	C_0		Reference speed	Limiting speed		
mm			kN		kN	r/min		kg	-
12	21	5	1,74	0,915	0,039	70 000	43 000	0,0063	61801
	24	6	2,91	1,46	0,062	67 000	40 000	0,011	61901
	28	8	5,4	2,36	0,1	60 000	38 000	0,021	* 6001
	30	8	5,07	2,36	0,1	60 000	38 000	0,026	16101
	32	10	7,28	3,1	0,132	50 000	32 000	0,037	* 6201
	37	12	10,1	4,15	0,176	45 000	28 000	0,06	* 6301
15	24	5	1,9	1,1	0,048	60 000	38 000	0,0065	61802
	28	7	4,36	2,24	0,095	56 000	34 000	0,016	61902
	32	8	5,85	2,85	0,12	50 000	32 000	0,03	* 16002
	32	9	5,85	2,85	0,12	50 000	32 000	0,03	* 6002
	35	11	8,06	3,75	0,16	43 000	28 000	0,045	* 6202
	42	13	11,9	5,4	0,228	38 000	24 000	0,082	* 6302
17	26	5	2,03	1,27	0,054	56 000	34 000	0,0075	61803
	30	7	4,62	2,55	0,108	50 000	32 000	0,016	61903
	35	8	6,37	3,25	0,137	45 000	28 000	0,038	* 16003
	35	10	6,37	3,25	0,137	45 000	28 000	0,038	* 6003
	40	12	9,95	4,75	0,2	38 000	24 000	0,065	* 6203
	40	12	11,4	5,4	0,228	38 000	24 000	0,064	6203 ETN9
20	47	14	14,3	6,55	0,275	34 000	22 000	0,11	* 6303
	62	17	22,9	10,8	0,455	28 000	18 000	0,27	6403
	32	7	4,03	2,32	0,104	45 000	28 000	0,018	61804
	37	9	6,37	3,65	0,156	43 000	26 000	0,037	61904
	42	8	7,28	4,05	0,173	38 000	24 000	0,05	* 16004
	42	12	9,95	5	0,212	38 000	24 000	0,067	* 6004
22	47	14	13,5	6,55	0,28	32 000	20 000	0,11	* 6204
	47	14	15,6	7,65	0,325	32 000	20 000	0,098	6204 ETN9
	52	15	16,8	7,8	0,335	30 000	19 000	0,14	* 6304
	52	15	18,2	9	0,38	30 000	19 000	0,14	6304 ETN9
	72	19	30,7	15	0,64	24 000	15 000	0,41	6404
	50	14	14	7,65	0,325	30 000	19 000	0,13	62/22
56	16	18,6	9,3	0,39	28 000	18 000	0,18	63/22	

* SKF Explorer bearing

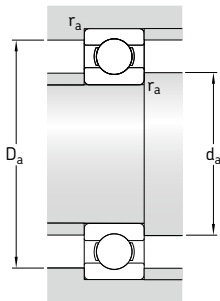

Dimensions					Abutment and fillet dimensions			Calculation factors	
d	d_1 ~	D_1 ~	D_2 ~	$r_{1,2}$ min.	d_a min.	D_a max.	r_a max.	k_f	f_0
mm					mm			-	
12	14,8	18,3	-	0,3	14	19	0,3	0,015	13
	16	20,3	-	0,3	14	22	0,3	0,02	15
	17	23,2	24,8	0,3	14	26	0,3	0,025	13
	17	23,4	24,8	0,3	14,4	27,6	0,3	0,025	13
	18,4	25,7	27,4	0,6	16,2	27,8	0,6	0,025	12
	19,5	29,5	31,5	1	17,6	31,4	1	0,03	11
15	17,8	21,3	-	0,3	17	22	0,3	0,015	14
	18,8	24,2	25,3	0,3	17	26	0,3	0,02	14
	20,5	26,7	28,2	0,3	17	30	0,3	0,02	14
	20,5	26,7	28,2	0,3	17	30	0,3	0,025	14
	21,7	29	30,4	0,6	19,2	30,8	0,6	0,025	13
	23,7	33,7	36,3	1	20,6	36,4	1	0,03	12
17	19,8	23,3	-	0,3	19	24	0,3	0,015	14
	20,4	26,6	27,7	0,3	19	28	0,3	0,02	15
	23	29,2	31,2	0,3	19	33	0,3	0,02	14
	23	29,2	31,2	0,3	19	33	0,3	0,025	14
	24,5	32,7	35	0,6	21,2	35,8	0,6	0,025	13
	24,5	32,7	-	0,6	21,2	35,8	0,6	0,03	12
20	26,5	37,4	39,6	1	22,6	41,4	1	0,03	12
	32,4	46,6	48,7	1,1	23,5	55,5	1	0,035	11
	23,8	28,3	-	0,3	22	30	0,3	0,015	15
	25,5	31,4	32,7	0,3	22	35	0,3	0,02	15
	27,3	34,6	-	0,3	22	40	0,3	0,02	15
	27,2	34,8	37,2	0,6	23,2	38,8	0,6	0,025	14
22	28,8	38,5	40,6	1	25,6	41,4	1	0,025	13
	28,2	39,6	-	1	25,6	41,4	1	0,025	12
	30,3	41,6	44,8	1,1	27	45	1	0,03	12
	30,3	42,6	-	1,1	27	45	1	0,03	12
	37,1	54,8	-	1,1	29	63	1	0,035	11
	32,2	41,8	44	1	27,6	44,4	1	0,025	14
	32,9	45,3	-	1,1	29	47	1	0,03	12

1.1 Single row deep groove ball bearings d 25 – 35 mm

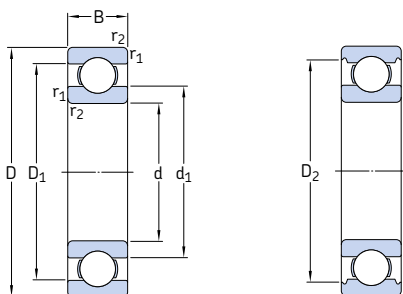

Principal dimensions			Basic load ratings		Fatigue load limit P_u	Speed ratings		Mass	Designation
d	D	B	C	C_0		Reference speed	Limiting speed		
mm			kN		kN	r/min		kg	-
25	37	7	4,36	2,6	0,125	38 000	24 000	0,022	61805
	42	9	7,02	4,3	0,193	36 000	22 000	0,045	61905
	47	8	8,06	4,75	0,212	32 000	20 000	0,06	* 16005
	47	12	11,9	6,55	0,275	32 000	20 000	0,078	* 6005
	52	15	14,8	7,8	0,335	28 000	18 000	0,13	* 6205
	52	15	17,8	9,8	0,4	28 000	18 000	0,12	6205 ETN9
	62	17	23,4	11,6	0,49	24 000	16 000	0,23	* 6305
	62	17	26	13,4	0,57	24 000	16 000	0,22	6305 ETN9
	80	21	35,8	19,3	0,815	20 000	13 000	0,54	6405
	28	58	16	16,8	9,5	0,405	26 000	16 000	0,17
68		18	25,1	13,7	0,585	22 000	14 000	0,3	63/28
30	42	7	4,49	2,9	0,146	32 000	20 000	0,025	61806
	47	9	7,28	4,55	0,212	30 000	19 000	0,049	61906
	55	9	11,9	7,35	0,31	28 000	17 000	0,089	* 16006
	55	13	13,8	8,3	0,355	28 000	17 000	0,12	* 6006
	62	16	20,3	11,2	0,475	24 000	15 000	0,2	* 6206
	62	16	23,4	12,9	0,54	24 000	15 000	0,18	6206 ETN9
	72	19	29,6	16	0,67	20 000	13 000	0,35	* 6306
	72	19	32,5	17,3	0,735	22 000	14 000	0,33	6306 ETN9
90	23	43,6	23,6	1	18 000	11 000	0,75	6406	
35	47	7	4,36	3,35	0,14	30 000	18 000	0,029	61807
	55	10	10,8	7,8	0,325	26 000	16 000	0,08	61907
	62	9	13	8,15	0,375	24 000	15 000	0,11	* 16007
	62	14	16,8	10,2	0,44	24 000	15 000	0,15	* 6007
	72	17	27	15,3	0,655	20 000	13 000	0,29	* 6207
	72	17	31,2	17,6	0,75	20 000	13 000	0,26	6207 ETN9
	80	21	35,1	19	0,815	19 000	12 000	0,46	* 6307
	100	25	55,3	31	1,29	16 000	10 000	0,97	6407

* SKF Explorer bearing

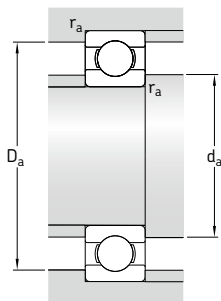

Dimensions					Abutment and fillet dimensions			Calculation factors	
d	d_1 ~	D_1 ~	D_2 ~	$r_{1,2}$ min.	d_a min.	D_a max.	r_a max.	k_f	f_0
mm					mm			-	
25	28,5	33,2	-	0,3	27	35	0,3	0,015	14
	30,2	36,8	37,7	0,3	27	40	0,3	0,02	15
	33,3	40,7	-	0,3	27	45	0,3	0,02	15
	32	40	42,2	0,6	28,2	43,8	0,6	0,025	14
	34,3	44	46,3	1	30,6	46,4	1	0,025	14
	33,1	44,5	-	1	30,6	46,4	1	0,025	13
	36,6	50,4	52,7	1,1	32	55	1	0,03	12
	36,3	51,7	-	1,1	32	55	1	0,03	12
	45,4	62,9	-	1,5	34	71	1,5	0,035	12
	28	37	49	51,5	1	33,6	52,4	1	0,025
41,7		55,5	57,8	1,1	35	61	1	0,03	13
30	33,7	38,4	-	0,3	32	40	0,3	0,015	14
	35,2	41,7	42,7	0,3	32	45	0,3	0,02	14
	37,7	47,3	-	0,3	32	53	0,3	0,02	15
	38,2	46,8	49	1	34,6	50,4	1	0,025	15
	40,3	51,6	54,1	1	35,6	56,4	1	0,025	14
	39,5	52,9	-	1	35,6	56,4	1	0,025	13
	44,6	59,1	61,9	1,1	37	65	1	0,03	13
	42,3	59,6	-	1,1	37	65	1	0,03	12
50,3	69,7	-	1,5	41	79	1,5	0,035	12	
35	38,2	42,8	-	0,3	37	45	0,3	0,015	14
	42,2	50,1	52,2	0,6	38,2	51,8	0,6	0,02	16
	44	53	-	0,3	37	60	0,3	0,02	14
	43,7	53,3	55,7	1	39,6	57,4	1	0,025	15
	46,9	60	62,7	1,1	42	65	1	0,025	14
	46,1	61,7	-	1,1	42	65	1	0,025	13
	49,5	65,4	69,2	1,5	44	71	1,5	0,03	13
	57,4	79,6	-	1,5	46	89	1,5	0,035	12

1.1 Single row deep groove ball bearings d 40 – 55 mm

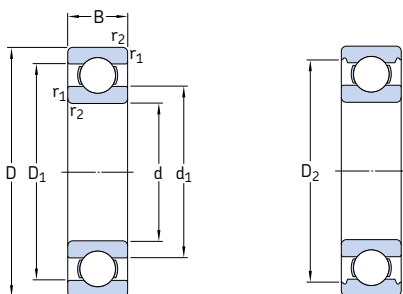

Principal dimensions			Basic load ratings		Fatigue load limit P_u	Speed ratings		Mass	Designation	
d	D	B	C	C_0		Reference speed	Limiting speed			
mm			kN		kN	r/min		kg	–	
40	52	7	4,49	3,75	0,16	26 000	16 000	0,032	61808	
	62	12	13,8	10	0,425	24 000	14 000	0,12	61908	
	68	9	13,8	10,2	0,44	22 000	14 000	0,13	* 16008	
	68	15	17,8	11	0,49	22 000	14 000	0,19	* 6008	
	80	18	32,5	19	0,8	18 000	11 000	0,37	* 6208	
	80	18	35,8	20,8	0,88	18 000	11 000	0,34	6208 ETN9	
	90	23	42,3	24	1,02	17 000	11 000	0,63	* 6308	
	110	27	63,7	36,5	1,53	14 000	9 000	1,25	6408	
	45	58	7	6,63	6,1	0,26	22 000	14 000	0,04	61809
		68	12	14	10,8	0,465	20 000	13 000	0,14	61909
75		10	16,5	10,8	0,52	20 000	12 000	0,17	* 16009	
75		16	22,1	14,6	0,64	20 000	12 000	0,24	* 6009	
85		19	35,1	21,6	0,915	17 000	11 000	0,42	* 6209	
100		25	55,3	31,5	1,34	15 000	9 500	0,84	* 6309	
120	29	76,1	45	1,9	13 000	8 500	1,55	6409		
50	65	7	6,76	6,8	0,285	20 000	13 000	0,052	61810	
	72	12	14,6	11,8	0,5	19 000	12 000	0,14	61910	
	80	10	16,8	11,4	0,56	18 000	11 000	0,18	* 16010	
	80	16	22,9	16	0,71	18 000	11 000	0,26	* 6010	
	90	20	37,1	23,2	0,98	15 000	10 000	0,45	* 6210	
110	27	65	38	1,6	13 000	8 500	1,1	* 6310		
130	31	87,1	52	2,2	12 000	7 500	1,95	6410		
55	72	9	9,04	8,8	0,375	19 000	12 000	0,083	61811	
	80	13	16,5	14	0,6	17 000	11 000	0,19	61911	
	90	11	20,3	14	0,695	16 000	10 000	0,27	* 16011	
	90	18	29,6	21,2	0,9	16 000	10 000	0,39	* 6011	
	100	21	46,2	29	1,25	14 000	9 000	0,61	* 6211	
	120	29	74,1	45	1,9	12 000	8 000	1,35	* 6311	
140	33	99,5	62	2,6	11 000	7 000	2,35	6411		

* SKF Explorer bearing

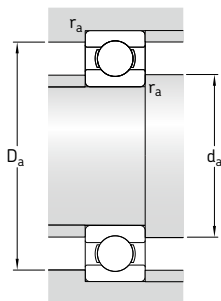

Dimensions					Abutment and fillet dimensions			Calculation factors		
d	d_1 ~	D_1 ~	D_2 ~	$r_{1,2}$ min.	d_a min.	D_a max.	r_a max.	k_f	f_0	
mm					mm			-		
40	43,2	48,1	-	0,3	42	50	0,3	0,015	15	
	46,9	55,1	-	0,6	43,2	58,8	0,6	0,02	16	
	49,4	58,6	-	0,3	42	66	0,3	0,02	16	
	49,2	58,8	61,1	1	44,6	63,4	1	0,025	15	
	52,6	67,4	69,8	1,1	47	73	1	0,025	14	
	52	68,8	-	1,1	47	73	1	0,025	13	
	56,1	73,8	77,7	1,5	49	81	1,5	0,03	13	
	62,8	87	-	2	53	97	2	0,035	12	
	45	49,1	53,9	-	0,3	47	56	0,3	0,015	17
		52,4	60,6	-	0,6	48,2	64,8	0,6	0,02	16
55		65	-	0,6	48,2	71,8	0,6	0,02	14	
54,7		65,3	67,8	1	50,8	69,2	1	0,025	15	
57,6		72,4	75,2	1,1	52	78	1	0,025	14	
62,1		82,7	86,7	1,5	54	91	1,5	0,03	13	
68,9	95,9	-	2	58	107	2	0,035	12		
50	55,1	59,9	-	0,3	52	63	0,3	0,015	17	
	56,9	65,1	-	0,6	53,2	68,8	0,6	0,02	16	
	60	70	-	0,6	53,2	76,8	0,6	0,02	14	
	59,7	70,3	72,8	1	54,6	75,4	1	0,025	15	
	62,5	77,4	81,7	1,1	57	83	1	0,025	14	
	68,7	91,1	95,2	2	61	99	2	0,03	13	
75,4	105	-	2,1	64	116	2	0,035	12		
55	60,6	66,4	-	0,3	57	70	0,3	0,015	17	
	63,2	71,8	-	1	59,6	75,4	1	0,02	16	
	67	78,1	-	0,6	58,2	86,8	0,6	0,02	14	
	66,3	78,7	81,5	1,1	61	84	1	0,025	15	
	69	85,8	89,4	1,5	64	91	1,5	0,025	14	
	75,3	99,5	104	2	66	109	2	0,03	13	
	81,5	114	-	2,1	69	126	2	0,035	12	

1.1 Single row deep groove ball bearings d 60 – 75 mm

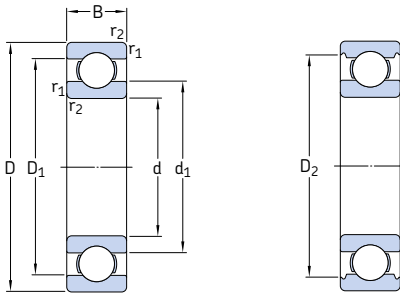

Principal dimensions			Basic load ratings		Fatigue load limit P_u	Speed ratings		Mass	Designation
d	D	B	C	C_0		Reference speed	Limiting speed		
mm			kN		kN	r/min		kg	–
60	78	10	11,9	11,4	0,49	17 000	11 000	0,11	61812
	85	13	16,5	14,3	0,6	16 000	10 000	0,2	61912
	95	11	20,8	15	0,735	15 000	9 500	0,29	* 16012
	95	18	30,7	23,2	0,98	15 000	9 500	0,41	* 6012
	110	22	55,3	36	1,53	13 000	8 000	0,78	* 6212
	130	31	85,2	52	2,2	11 000	7 000	1,7	* 6312
	150	35	108	69,5	2,9	10 000	6 300	2,85	6412
65	85	10	12,4	12,7	0,54	16 000	10 000	0,13	61813
	90	13	17,4	16	0,68	15 000	9 500	0,22	61913
	100	11	22,5	19,6	0,83	14 000	9 000	0,3	* 16013
	100	18	31,9	25	1,06	14 000	9 000	0,44	* 6013
	120	23	58,5	40,5	1,73	12 000	7 500	1	* 6213
	140	33	97,5	60	2,5	10 000	6 700	2,1	* 6313
	160	37	119	78	3,15	9 500	6 000	3,35	6413
70	90	10	12,4	13,2	0,56	15 000	9 000	0,14	61814
	100	16	23,8	21,2	0,9	14 000	8 500	0,35	61914
	110	13	29,1	25	1,06	13 000	8 000	0,44	* 16014
	110	20	39,7	31	1,32	13 000	8 000	0,61	* 6014
	125	24	63,7	45	1,9	11 000	7 000	1,1	* 6214
	150	35	111	68	2,75	9 500	6 300	2,55	* 6314
	180	42	143	104	3,9	8 500	5 300	4,95	6414
75	95	10	12,7	14,3	0,61	14 000	8 500	0,15	61815
	105	16	24,2	22,4	0,965	13 000	8 000	0,37	61915
	115	13	30,2	27	1,14	12 000	7 500	0,46	* 16015
	115	20	41,6	33,5	1,43	12 000	7 500	0,65	* 6015
	130	25	68,9	49	2,04	10 000	6 700	1,2	* 6215
	160	37	119	76,5	3	9 000	5 600	3,05	* 6315
	190	45	153	114	4,15	8 000	5 000	5,8	6415

* SKF Explorer bearing

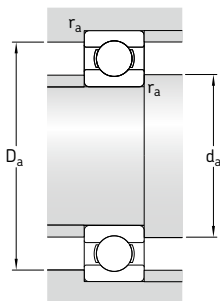

Dimensions				Abutment and fillet dimensions			Calculation factors		
d	d_1	D_1	D_2	$r_{1,2}$	d_a	D_a	r_a	k_r	f_0
mm	~	~	~	min.	mm	max.	max.	-	-
60	65,6	72,4	-	0,3	62	76	0,3	0,015	17
	68,2	76,8	-	1	64,6	80,4	1	0,02	16
	72	83	-	0,6	63,2	91,8	0,6	0,02	14
	71,3	83,7	86,5	1,1	66	89	1	0,025	16
	75,5	94,6	98	1,5	69	101	1,5	0,025	14
65	81,8	108	113	2,1	72	118	2	0,03	13
	88,1	122	-	2,1	74	136	2	0,035	12
	71,6	78,4	-	0,6	68,2	81,8	0,6	0,015	17
	73,2	81,8	-	1	69,6	85,4	1	0,02	17
	76,5	88,4	-	0,6	68,2	96,8	0,6	0,02	16
70	76,3	88,7	91,5	1,1	71	94	1	0,025	16
	83,3	103	106	1,5	74	111	1,5	0,025	15
	88,3	117	122	2,1	77	128	2	0,03	13
	94	131	-	2,1	79	146	2	0,035	12
	76,6	83,4	-	0,6	73,2	86,8	0,6	0,015	17
75	79,7	90,3	-	1	74,6	95,4	1	0,02	16
	83,3	96,8	-	0,6	73,2	106	0,6	0,02	16
	82,8	97,2	99,9	1,1	76	104	1	0,025	16
	87	108	111	1,5	79	116	1,5	0,025	15
	94,9	125	130	2,1	82	138	2	0,03	13
75	103	146	-	3	86	164	2,5	0,035	12
	81,6	88,4	-	0,6	78,2	91,8	0,6	0,015	17
	84,7	95,3	-	1	79,6	100	1	0,02	17
	88,3	102	-	0,6	78,2	111	0,6	0,02	16
	87,8	103	105	1,1	81	109	1	0,025	16
75	92	113	117	1,5	84	121	1,5	0,025	15
	101	134	139	2,1	87	148	2	0,03	13
	110	155	-	3	91	174	2,5	0,035	12

1.1 Single row deep groove ball bearings d 80 – 100 mm

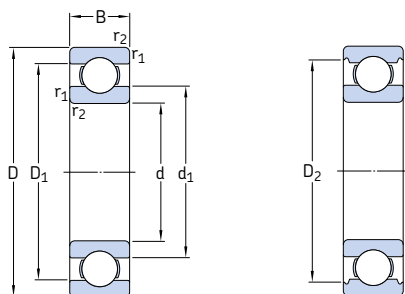

Principal dimensions			Basic load ratings		Fatigue load limit P_u	Speed ratings		Mass	Designation
d	D	B	C	C_0		Reference speed	Limiting speed		
mm			kN		kN	r/min	kg	–	
80	100	10	13	15	0,64	13 000	8 000	0,15	61816
	110	16	25,1	20,4	1,02	12 000	7 500	0,38	61916
	125	14	35,1	31,5	1,32	11 000	7 000	0,61	* 16016
	125	22	49,4	40	1,66	11 000	7 000	0,87	* 6016
	140	26	72,8	55	2,2	9 500	6 000	1,45	* 6216
	170	39	130	86,5	3,25	8 500	5 300	3,65	* 6316
	200	48	163	125	4,5	7 500	4 800	6,85	6416
85	110	13	19,5	20,8	0,88	12 000	7 500	0,27	61817
	120	18	31,9	30	1,25	11 000	7 000	0,55	61917
	130	14	35,8	33,5	1,37	11 000	6 700	0,64	* 16017
	130	22	52	43	1,76	11 000	6 700	0,92	* 6017
	150	28	87,1	64	2,5	9 000	5 600	1,8	* 6217
	180	41	140	96,5	3,55	8 000	5 000	4,25	* 6317
	210	52	174	137	4,75	7 000	4 500	8,05	6417
90	115	13	19,5	22	0,915	11 000	7 000	0,28	61818
	125	18	33,2	31,5	1,29	11 000	6 700	0,59	61918
	140	16	43,6	39	1,56	10 000	6 300	0,85	* 16018
	140	24	60,5	50	1,96	10 000	6 300	1,15	* 6018
	160	30	101	73,5	2,8	8 500	5 300	2,2	* 6218
	190	43	151	108	3,8	7 500	4 800	4,95	* 6318
	225	54	186	150	5	6 700	4 300	9,8	6418
95	120	13	19,9	22,8	0,93	11 000	6 700	0,3	61819
	130	18	33,8	33,5	1,34	10 000	6 300	0,61	61919
	145	16	44,9	41,5	1,63	9 500	6 000	0,89	* 16019
	145	24	63,7	54	2,08	9 500	6 000	1,1	* 6019
	170	32	114	81,5	3	8 000	5 000	2,65	* 6219
	200	45	159	118	4,15	7 000	4 500	5,75	* 6319
	100	125	13	17,8	18,3	0,95	10 000	6 300	0,31
140		20	42,3	41,5	1,63	9 500	6 000	0,83	61920
150		16	46,2	44	1,7	9 500	5 600	0,94	* 16020
150		24	63,7	54	2,04	9 500	5 600	1,25	* 6020
180		34	127	93	3,35	7 500	4 800	3,15	* 6220
215		47	174	140	4,75	6 700	4 300	7,1	6320

* SKF Explorer bearing

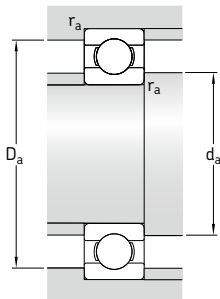

Dimensions				Abutment and fillet dimensions			Calculation factors		
d	d_1 ~	D_1 ~	D_2 ~	$r_{1,2}$ min.	d_a min.	D_a max.	r_a max.	k_f	f_0
mm				mm			-		
80	86,6	93,4	-	0,6	83,2	96,8	0,6	0,015	17
	89,8	101	103	1	84,6	105	1	0,02	14
	95,3	110	-	0,6	83,2	121	0,6	0,02	16
	94,4	111	115	1,1	86	119	1	0,025	16
	101	123	127	2	91	129	2	0,025	15
	108	142	147	2,1	92	158	2	0,03	13
	116	163	-	3	96	184	2,5	0,035	12
	93,2	102	-	1	89,6	105	1	0,015	17
	96,4	109	-	1,1	91	114	1	0,02	16
	100	115	-	0,6	88,2	126	0,6	0,02	17
99,4	116	120	1,1	92	123	1	0,025	16	
106	130	135	2	96	139	2	0,025	15	
114	151	156	3	99	166	2,5	0,03	13	
123	172	-	4	105	190	3	0,035	12	
90	98,2	107	-	1	94,6	110	1	0,015	17
	101	114	-	1,1	96	119	1	0,02	17
	106	124	-	1	94,6	135	1	0,02	16
	105	125	129	1,5	97	133	1,5	0,025	16
	112	138	143	2	101	149	2	0,025	15
	121	159	164	3	104	176	2,5	0,03	13
	132	181	-	4	110	205	3	0,035	13
	103	112	-	1	99,6	115	1	0,015	17
106	119	-	1,1	101	124	1	0,02	17	
111	129	-	1	99,6	140	1	0,02	16	
111	130	134	1,5	102	138	1,5	0,025	16	
118	147	152	2,1	107	158	2	0,025	14	
127	168	172	3	109	186	2,5	0,03	13	
100	108	117	-	1	105	120	1	0,015	13
	112	128	-	1,1	106	134	1	0,02	16
	116	134	-	1	105	145	1	0,02	17
	115	135	139	1,5	107	143	1,5	0,025	16
	124	155	160	2,1	112	168	2	0,025	14
	135	180	184	3	114	201	2,5	0,03	13

1.1 Single row deep groove ball bearings d 105 – 140 mm

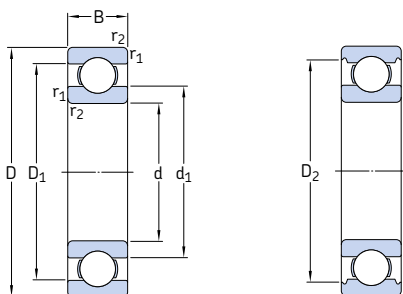

Principal dimensions			Basic load ratings		Fatigue load limit	Speed ratings		Mass	Designation
d	D	B	dynamic	static		Reference speed	Limiting speed		
mm			C	C ₀	P _u	r/min	kg	-	
105	130	13	20,8	19,6	1	10 000	6 300	0,32	61821
	145	20	44,2	44	1,7	9 500	5 600	0,87	61921
	160	18	54	51	1,86	8 500	5 300	1,2	* 16021
	160	26	76,1	65,5	2,4	8 500	5 300	1,6	* 6021
	190	36	140	104	3,65	7 000	4 500	3,8	* 6221
	225	49	182	153	5,1	6 300	4 000	8,15	6321
110	140	16	28,1	26	1,25	9 500	5 600	0,49	61822
	150	20	43,6	45	1,66	9 000	5 600	0,9	61922
	170	19	60,5	57	2,04	8 000	5 000	1,45	* 16022
	170	28	85,2	73,5	2,6	8 000	5 000	1,95	* 6022
	200	38	151	118	4	6 700	4 300	4,45	* 6222
	240	50	203	180	5,7	6 000	3 800	9,65	6322
120	150	16	29,1	28	1,29	8 500	5 300	0,54	61824
	165	22	55,3	57	2,04	8 000	5 000	1,2	61924
	180	19	63,7	64	2,2	7 500	4 800	1,55	* 16024
	180	28	88,4	80	2,75	7 500	4 800	2,1	* 6024
	215	40	146	118	3,9	6 300	4 000	5,25	6224
	260	55	208	186	5,7	5 600	3 400	12,5	6324
130	165	18	37,7	43	1,6	8 000	4 800	0,77	61826
	180	24	65	67	2,28	7 500	4 500	1,6	61926
	200	22	83,2	81,5	2,7	7 000	4 300	2,35	* 16026
	200	33	112	100	3,35	7 000	4 300	3,25	* 6026
	230	40	156	132	4,15	5 600	3 600	5,85	6226
	280	58	229	216	6,3	5 000	3 200	15	6326
	280	58	229	216	6,3	5 000	4 500	17,5	6326 M
140	175	18	39	46,5	1,66	7 500	4 500	0,85	61828
	190	24	66,3	72	2,36	7 000	4 300	1,7	61928
	190	24	66,3	72	2,36	7 000	5 600	2	61928 MA
	210	22	80,6	86,5	2,8	6 700	4 000	2,55	16028
	210	33	111	108	3,45	6 700	4 000	3,45	6028
	250	42	165	150	4,55	5 300	3 400	7,75	6228
	300	62	251	245	7,1	4 800	3 000	18,5	6328
	300	62	251	245	7,1	4 800	4 300	21,5	6328 M

* SKF Explorer bearing

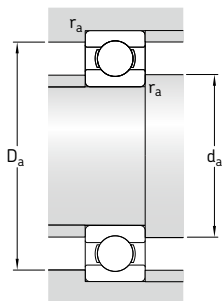

Dimensions					Abutment and fillet dimensions			Calculation factors	
d	d ₁	D ₁	D ₂	r _{1,2} min.	d _a min.	D _a max.	r _a max.	k _r	f ₀
mm	mm	mm	mm	mm	mm	mm	mm	-	-
105	112	123	-	1	110	125	1	0,015	13
	117	133	-	1,1	111	139	1	0,02	17
	123	142	-	1	110	155	1	0,02	16
	122	143	147	2	116	149	2	0,025	16
	131	164	167	2,1	117	178	2	0,025	14
	141	188	-	3	119	211	2,5	0,03	13
110	118	132	-	1	115	135	1	0,015	14
	122	138	-	1,1	116	144	1	0,02	17
	130	150	-	1	115	165	1	0,02	16
	129	151	156	2	119	161	2	0,025	16
	138	172	177	2,1	122	188	2	0,025	14
	149	200	-	3	124	226	2,5	0,03	13
120	128	142	-	1	125	145	1	0,015	14
	134	151	-	1,1	126	159	1	0,02	17
	139	161	-	1	125	175	1	0,02	17
	139	161	166	2	129	171	2	0,025	16
	150	185	190	2,1	132	203	2	0,025	14
	164	215	-	3	134	246	2,5	0,03	14
130	140	155	-	1,1	136	159	1	0,015	16
	145	164	-	1,5	137	173	1,5	0,02	16
	153	176	-	1,1	136	192	1	0,02	16
	152	177	182	2	139	191	2	0,025	16
	160	198	-	3	144	216	2,5	0,025	15
	177	232	-	4	147	263	3	0,03	14
177	232	-	4	147	263	3	0,03	14	
140	150	164	-	1,1	146	169	1	0,015	16
	156	174	-	1,5	147	183	1,5	0,02	15
	156	175	-	1,5	147	183	1,5	0,02	17
	163	186	-	1,1	146	204	1	0,02	17
	162	188	192	2	149	201	2	0,025	16
	175	213	-	3	154	236	2,5	0,025	15
190	249	-	4	157	283	3	0,03	14	
190	249	-	4	157	283	3	0,03	14	

1.1 Single row deep groove ball bearings d 150 – 180 mm

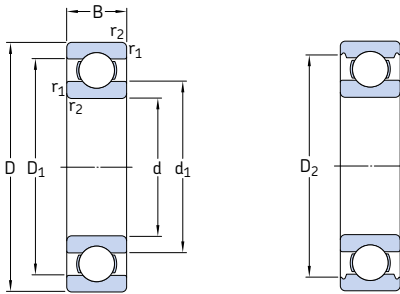

Principal dimensions			Basic load ratings		Fatigue load limit P_u	Speed ratings		Mass	Designation
d	D	B	C	C_0		Reference speed	Limiting speed		
mm			kN		kN	r/min		kg	-
150	190	20	48,8	61	1,96	6 700	4 300	1,2	61830
	210	28	88,4	93	2,9	6 300	5 300	3,05	61930 MA
	225	24	92,3	98	3,05	6 000	3 800	3,15	16030
	225	35	125	125	3,9	6 000	3 800	4,3	6030
	270	45	174	166	4,9	5 000	3 200	10	6230
	320	65	276	285	7,8	4 300	2 800	23	6330
	320	65	276	285	7,8	4 300	4 000	26	6330 M
160	200	20	49,4	64	2	6 300	4 000	1,25	61832
	220	28	92,3	98	3,05	6 000	3 800	2,7	61932
	220	28	92,3	98	3,05	6 000	5 000	3,2	61932 MA
	240	25	99,5	108	3,25	5 600	3 600	3,65	16032
	240	38	143	143	4,3	5 600	3 600	5,2	6032
	290	48	186	186	5,3	4 500	3 000	13	6232
	340	68	276	285	7,65	4 000	2 600	26	6332
340	68	276	285	7,65	4 000	3 800	30,5	6332 M	
170	215	22	61,8	78	2,4	6 000	3 600	1,65	61834
	230	28	93,6	106	3,15	5 600	4 800	3,4	61934 MA
	260	28	119	129	3,75	5 300	3 200	5	16034
	260	42	168	173	5	5 300	3 200	7	6034
	260	42	168	173	5	5 300	4 300	8,15	6034 M
	310	52	212	224	6,1	4 300	2 800	16	6234
	310	52	212	224	6,1	4 300	3 800	18	6234 M
360	72	312	340	8,8	3 800	2 400	31	6334	
360	72	312	340	8,8	3 800	3 400	36	6334 M	
180	225	22	62,4	81,5	2,45	5 600	3 400	1,75	61836
	250	33	119	134	3,9	5 300	3 200	5	61936
	250	33	119	134	3,9	5 300	4 300	5	61936 MA
	280	31	138	146	4,15	4 800	3 000	6,5	16036
	280	46	190	200	5,6	4 800	3 000	9,1	6036
	280	46	190	200	5,6	4 800	4 000	10,5	6036 M
	320	52	229	240	6,4	4 000	2 600	42	6236
	320	52	229	240	6,4	4 000	3 800	18,5	6236 M
	380	75	351	405	10,4	3 600	2 200	36,5	6336
	380	75	351	405	10,4	3 600	3 200	42	6336 M

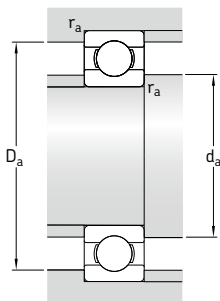

Dimensions					Abutment and fillet dimensions			Calculation factors	
d	d_1	D_1	D_2	$r_{1,2}$ min.	d_a min.	D_a max.	r_a max.	k_f	f_0
mm	mm	mm	mm	mm	mm	mm	mm	-	-
150	162	178	-	1,1	156	184	1	0,015	17
	169	191	-	2	159	201	2	0,02	16
	174	200	-	1,1	156	219	1	0,02	17
	174	200	206	2,1	160	215	2	0,025	16
	190	228	-	3	164	256	2,5	0,025	15
	205	264	-	4	167	303	3	0,03	14
205	264	-	4	167	303	3	0,03	14	
160	172	188	-	1,1	166	194	1	0,015	17
	179	201	-	2	169	211	2	0,02	17
	179	202	-	2	169	211	2	0,02	17
	185	214	-	1,5	167	233	1,5	0,02	17
	185	215	219	2,1	169	231	2	0,025	16
	205	243	-	3	174	276	2,5	0,025	15
218	281	-	4	177	323	3	0,03	14	
218	281	-	4	177	323	3	0,03	14	
170	184	202	-	1,1	176	209	1	0,015	17
	189	212	-	2	179	221	2	0,02	17
	200	229	-	1,5	177	253	1,5	0,02	16
	198	232	-	2,1	180	250	2	0,025	16
	198	232	-	2,1	180	250	2	0,025	16
	218	259	-	4	187	293	3	0,025	15
218	259	-	4	187	293	3	0,025	15	
230	299	-	4	187	343	3	0,03	14	
230	299	-	4	187	343	3	0,03	14	
180	194	211	-	1,1	186	219	1	0,015	17
	202	228	-	2	189	241	2	0,02	17
	202	229	-	2	189	241	2	0,02	17
	213	246	-	2	189	271	2	0,02	16
	212	248	-	2,1	190	270	2	0,025	16
	212	248	-	2,1	190	270	2	0,025	16
226	274	-	4	197	303	3	0,025	15	
226	274	-	4	197	303	3	0,025	15	
244	315	-	4	197	363	3	0,03	14	
244	315	-	4	197	363	3	0,03	14	

1.1 Single row deep groove ball bearings d 190 – 240 mm

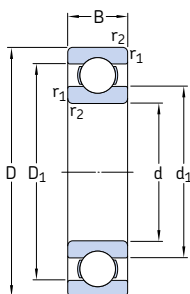

Principal dimensions			Basic load ratings		Fatigue load limit P_u	Speed ratings		Mass kg	Designation	
d	D	B	C	C_0		Reference speed	Limiting speed			
mm			kN		kN	r/min		kg	–	
190	240	24	76,1	98	2,8	5 300	3 200	2,25	61838	
	260	33	117	134	3,8	5 000	3 200	4,5	61938	
	260	33	117	134	3,8	5 000	4 300	5,2	61938 MA	
	290	31	148	166	4,55	4 800	3 000	6,9	16038	
	290	46	195	216	5,85	4 800	3 000	9,55	6038	
	290	46	195	216	5,85	4 800	3 800	11	6038 M	
	340	55	255	280	7,35	3 800	2 400	19,5	6238	
	340	55	255	280	7,35	3 800	3 400	22	6238 M	
	400	78	371	430	10,8	3 400	2 200	42	6338	
	400	78	371	430	10,8	3 400	3 000	48,5	6338 M	
200	250	24	76,1	102	2,9	5 000	3 200	2,35	61840	
	280	38	148	166	4,55	4 800	3 000	6,3	61940	
	280	38	148	166	4,55	4 800	3 800	7,3	61940 MA	
	310	34	168	190	5,1	4 300	2 800	8,8	16040	
	310	51	216	245	6,4	4 300	2 800	12,5	6040	
	310	51	216	245	6,4	4 300	3 600	14,5	6040 M	
	360	58	270	310	7,8	3 600	2 200	23,5	6240	
	360	58	270	310	7,8	3 600	3 200	26,5	6240 M	
220	270	24	78	110	3	4 500	2 800	2,55	61844	
	300	38	151	180	4,75	4 300	2 600	6,8	61944	
	300	38	151	180	4,75	4 300	3 600	7,95	61944 MA	
	340	37	174	204	5,2	4 000	2 400	11,5	16044	
	340	56	247	290	7,35	4 000	2 400	16	6044	
	340	56	247	290	7,35	4 000	3 200	19	6044 M	
	400	65	296	365	8,8	3 200	2 000	33,5	6244	
	400	65	296	365	8,8	3 200	3 000	37	6244 M	
	240	300	28	108	150	3,8	4 000	2 600	3,9	61848
		320	38	159	200	5,1	4 000	2 400	7,3	61948
320		38	159	200	5,1	4 000	3 200	8,55	61948 MA	
360		37	203	255	6,3	3 600	2 200	12,5	16048	
360		37	203	255	6,3	3 600	3 000	14	16048 MA	
360		56	255	315	7,8	3 600	2 200	17	6048	
360		56	255	315	7,8	3 600	3 000	20,5	6048 M	
500		95	442	585	12,9	2 600	2 400	92,5	6348 M	

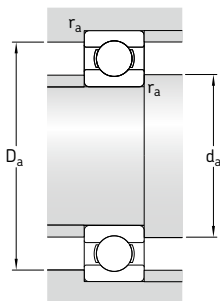

Dimensions				Abutment and fillet dimensions			Calculation factors		
d	d_1 ~	D_1 ~	$r_{1,2}$ min.	d_a min.	D_a max.	r_a max.	k_r	f_0	
mm				mm			-		
190	206	224	1,5	197	233	1,5	0,015	17	
	212	238	2	199	251	2	0,02	17	
	212	239	2	199	251	2	0,02	17	
	223	256	2	199	281	2	0,02	16	
	222	258	2,1	200	280	2	0,025	16	
	222	258	2,1	200	280	2	0,025	16	
	239	249	4	207	323	3	0,025	15	
	239	290	4	207	323	3	0,025	15	
	259	331	5	210	380	4	0,03	14	
	259	331	5	210	380	4	0,03	14	
200	216	234	1,5	207	243	1,5	0,015	17	
	225	255	2,1	210	270	2	0,02	16	
	225	256	2,1	210	270	2	0,02	16	
	237	273	2	209	301	2	0,02	16	
	235	275	2,1	210	300	2	0,025	16	
	235	275	2,1	210	300	2	0,025	16	
	254	303	4	217	343	3	0,025	15	
	254	303	4	217	343	3	0,025	15	
	220	236	254	1,5	227	263	1,5	0,015	17
		245	275	2,1	230	290	2	0,02	17
245		276	2,1	230	290	2	0,02	17	
261		298	2,1	230	330	2	0,02	17	
258		302	3	233	327	2,5	0,025	16	
258		302	3	233	327	2,5	0,025	16	
282		335	4	237	383	3	0,025	15	
282		335	4	237	383	3	0,025	15	
240		259	281	2	249	291	2	0,015	17
		265	295	2,1	250	310	2	0,02	17
	265	296	2,1	250	310	2	0,02	17	
	279	318	2,1	250	350	2	0,02	17	
	279	321	2,1	250	350	2	0,02	17	
	277	322	3	253	347	2,5	0,025	16	
	277	322	3	253	347	2,5	0,025	16	
	330	411	5	260	480	4	0,03	15	

1.1 Single row deep groove ball bearings d 260 – 360 mm

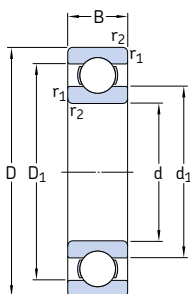

Principal dimensions			Basic load ratings		Fatigue load limit	Speed ratings		Mass	Designation
d	D	B	C	C ₀		Reference speed	Limiting speed		
mm			kN		kN	r/min	kg	–	
260	320	28	111	163	4	3 800	2 400	4,15	61852
	360	46	212	270	6,55	3 600	2 200	12	61952
	360	46	212	270	6,55	3 600	3 000	14,5	61952 MA
	400	44	238	310	7,2	3 200	2 000	18	16052
	400	44	238	310	7,2	3 200	2 800	22,5	16052 MA
	400	65	291	375	8,8	3 200	2 000	25	6052
	400	65	291	375	8,8	3 200	2 800	30	6052 M
	400	65	291	375	8,8	3 200	2 800	30	6052 M
280	350	33	138	200	4,75	3 400	2 200	6,25	61856
	380	46	216	285	6,7	3 200	2 000	12	61956
	380	46	216	285	6,7	3 200	2 800	15,5	61956 MA
	420	44	242	335	7,5	3 000	1 900	19	16056
	420	44	242	335	7,5	3 000	2 600	24	16056 MA
	420	65	302	405	9,3	3 000	1 900	26	6056
	420	65	302	405	9,3	3 000	2 600	31,5	6056 M
	420	65	302	405	9,3	3 000	2 600	31,5	6056 M
300	380	38	172	245	5,6	3 200	2 000	8,9	61860
	380	38	172	245	5,6	3 200	2 600	10,5	61860 MA
	420	56	270	375	8,3	3 000	1 900	19	61960
	420	56	270	375	8,3	3 000	2 400	24,5	61960 MA
	540	85	462	670	13,7	2 400	2 000	88,5	6260 M
	540	85	462	670	13,7	2 400	2 000	88,5	6260 M
320	400	38	172	255	5,7	3 000	1 900	9,5	61864
	400	38	172	255	5,7	3 000	2 400	11	61864 MA
	480	50	281	405	8,65	2 600	2 200	34	16064 MA
	480	74	371	540	11,4	2 600	2 200	46	6064 M
340	420	38	178	275	6	2 800	1 800	10	61868
	420	38	178	275	6	2 800	2 400	11,5	61868 MA
	520	57	345	520	10,6	2 400	2 000	45	16068 MA
	520	82	423	640	13,2	2 400	2 000	62	6068 M
360	440	38	182	285	6,1	2 600	2 200	12	61872 MA
	480	56	291	450	9,15	2 600	2 000	28	61972 MA
	540	57	351	550	11	1 800	1 400	49	16072 MA
	540	82	442	695	14	2 400	1 900	64,5	6072 M

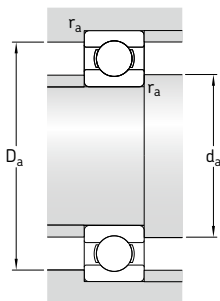

Dimensions				Abutment and fillet dimensions			Calculation factors	
d	d ₁ ~	D ₁ ~	r _{1,2} min.	d _a min.	D _a max.	r _a max.	k _r	f ₀
mm				mm			-	
260	279	301	2	269	311	2	0,015	17
	291	329	2,1	270	350	2	0,02	17
	291	330	2,1	270	350	2	0,02	17
	307	351	3	273	387	2,5	0,02	16
	307	353	3	273	387	2,5	0,02	16
	304	356	4	277	383	3	0,025	16
280	302	327	2	289	341	2	0,015	17
	311	349	2,1	291	369	2	0,02	17
	311	350	2,1	291	369	2	0,02	17
	327	371	3	293	407	2,5	0,02	17
	327	374	3	293	407	2,5	0,02	17
	324	376	4	296	404	3	0,025	16
300	325	355	2,1	309	371	2	0,015	17
	325	356	2,1	309	371	2	0,015	17
	338	382	3	313	407	2,5	0,02	16
	338	384	3	313	407	2,5	0,02	16
	383	457	5	320	520	4	0,025	15
	320	345	375	2,1	332	388	2	0,015
345		376	2,1	332	388	2	0,015	17
372		428	4	335	465	3	0,02	17
370		431	4	335	465	3	0,025	16
340		365	395	2,1	352	408	2	0,015
	365	396	2,1	352	408	2	0,015	17
	398	462	4	355	505	3	0,02	16
	397	463	5	360	500	4	0,025	16
	360	385	415	2,1	372	428	2	0,015
398		443	3	373	467	2,5	0,02	17
418		482	4	375	525	3	0,02	16
416		485	5	378	522	4	0,025	16

1.1 Single row deep groove ball bearings d 380 – 600 mm

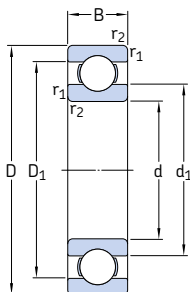

Principal dimensions			Basic load ratings		Fatigue load limit P_u	Speed ratings		Mass kg	Designation
d	D	B	C	C_0		Reference speed	Limiting speed		
mm			kN		kN	r/min		kg	–
380	480	46	242	390	8	2 400	2 000	20	61876 MA
	520	65	338	540	10,8	2 400	1 900	40	61976 MA
	560	57	377	620	12,2	1 700	1 400	51	16076 MA
	560	82	436	695	13,7	2 200	1 800	70,5	6076 M
400	500	46	247	405	8,15	2 400	1 900	20,5	61880 MA
	540	65	345	570	11,2	2 200	1 800	41,5	61980 MA
	600	90	520	865	16,3	2 000	1 700	87,5	6080 M
420	520	46	251	425	8,3	2 200	1 800	21,5	61884 MA
	560	65	351	600	11,4	2 200	1 800	43	61984 MA
	620	90	507	880	16,3	2 000	1 600	91,5	6084 M
440	540	46	255	440	8,5	2 200	1 800	22,5	61888 MA
	600	74	410	720	13,2	2 000	1 600	60,5	61988 MA
	650	94	553	965	17,6	1 900	1 500	105	6088 M
460	580	56	319	570	10,6	2 000	1 600	35	61892 MA
	620	74	423	750	13,7	1 900	1 600	62,5	61992 MA
	680	100	582	1 060	19	1 800	1 500	120	6092 MB
480	600	56	325	600	10,8	1 900	1 600	36,5	61896 MA
	650	78	449	815	14,6	1 800	1 500	74	61996 MA
	700	100	618	1 140	20	1 700	1 400	125	6096 MB
500	620	56	332	620	11,2	1 800	1 500	40,5	618/500 MA
	670	78	462	865	15	1 700	1 400	77	619/500 MA
	720	100	605	1 140	19,6	1 600	1 300	135	60/500 N1MAS
530	650	56	332	655	11,2	1 700	1 400	39,5	618/530 MA
	710	82	488	930	15,6	1 600	1 300	90,5	619/530 MA
	780	112	650	1 270	20,8	1 500	1 200	185	60/530 N1MAS
560	680	56	345	695	11,8	1 600	1 300	42	618/560 MA
	750	85	494	980	16,3	1 500	1 200	105	619/560 MA
	820	115	663	1 370	22	1 400	1 200	210	60/560 N1MAS
600	730	60	364	765	12,5	1 500	1 200	52	618/600 MA
	800	90	585	1 220	19,6	1 400	1 100	125	619/600 MA

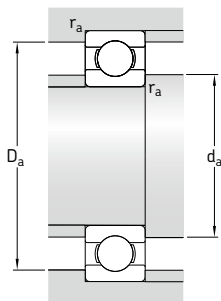

Dimensions				Abutment and fillet dimensions			Calculation factors	
d	d_1 ~	D_1 ~	$r_{1,2}$ min.	d_a min.	D_a max.	r_a max.	k_r	f_0
mm				mm			-	
380	412	449	2,1	392	468	2	0,015	17
	425	476	4	395	505	3	0,02	17
	443	497	4	395	545	3	0,02	17
	437	503	5	400	540	4	0,025	16
400	432	471	2,1	412	488	2	0,015	17
	445	496	4	415	525	3	0,02	17
	463	537	5	418	582	4	0,025	16
420	452	491	2,1	432	508	2	0,015	17
	465	516	4	435	545	3	0,02	17
	482	557	5	438	602	4	0,025	16
440	472	510	2,1	452	528	2	0,015	17
	492	549	4	455	585	3	0,02	17
	506	584	6	463	627	5	0,025	16
460	498	542	3	473	567	2,5	0,015	17
	511	569	4	476	604	3	0,02	17
	528	614	6	483	657	5	0,025	16
480	518	564	3	493	587	2,5	0,015	17
	535	595	5	498	632	4	0,02	17
	550	630	6	503	677	5	0,025	16
500	538	582	3	513	607	2,5	0,015	17
	555	617	5	518	652	4	0,02	17
	568	650	6	523	697	5	0,025	16
530	568	613	3	543	637	2,5	0,015	17
	587	653	5	548	692	4	0,02	17
	612	700	6	553	757	5	0,025	16
560	598	644	3	573	667	2,5	0,015	17
	622	689	5	578	732	4	0,02	17
	648	732	6	583	797	5	0,025	16
600	642	688	3	613	717	2,5	0,015	18
	663	736	5	618	782	4	0,02	17

1.1 Single row deep groove ball bearings

d 630 – 1 180 mm

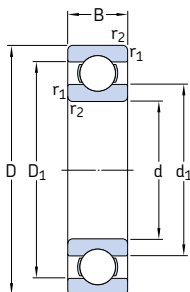

Principal dimensions			Basic load ratings		Fatigue load limit P_u	Speed ratings		Mass	Designation
d	D	B	C	C_0		Reference speed	Limiting speed		
mm			kN		kN	r/min		kg	–
630	780	69	442	965	15,3	1 400	1 100	73	618/630 MA
	850	100	624	1 340	21,2	1 300	1 100	160	619/630 N1MA
	920	128	819	1 760	27	1 200	1 000	285	60/630 N1MBS
670	820	69	442	1 000	15,6	1 300	1 100	83,5	618/670 MA
	900	103	676	1 500	22,4	1 200	1 000	185	619/670 MA
	980	136	904	2 040	30	1 100	900	345	60/670 N1MAS
710	870	74	475	1 100	16,6	1 200	1 000	93,5	618/710 MA
	950	106	663	1 500	22	1 100	900	220	619/710 MA
	1 030	140	956	2 200	31,5	1 000	850	375	60/710 MA
750	920	78	527	1 250	18,3	1 100	900	110	618/750 MA
	1 000	112	761	1 800	25,5	1 000	850	255	619/750 MA
800	980	82	559	1 370	19,3	1 000	850	130	618/800 MA
	1 060	115	832	2 040	28,5	950	800	275	619/800 MA
	1 150	155	1 010	2 550	34,5	900	750	535	60/800 N1MAS
850	1 030	82	559	1 430	19,6	950	750	140	618/850 MA
	1 120	118	832	2 160	29	850	750	310	619/850 MA
1 000	1 220	100	637	1 800	22,8	750	600	245	618/1000 MA
1 060	1 280	100	728	2 120	26,5	670	560	260	618/1060 MA
1 120	1 360	106	741	2 200	26,5	630	530	315	618/1120 MA
1 180	1 420	106	761	2 360	27,5	560	480	330	618/1180 MB

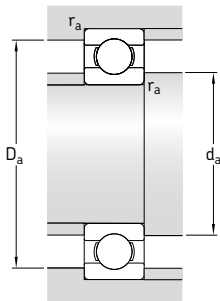

Dimensions				Abutment and fillet dimensions			Calculation factors	
d	d_1 ~	D_1 ~	$r_{1,2}$ min.	d_a min.	D_a max.	r_a max.	k_r	f_0
mm				mm			-	
630	678	732	4	645	765	3	0,015	17
	702	778	6	653	827	5	0,02	17
	725	825	7,5	658	892	6	0,025	16
670	718	772	4	685	805	3	0,015	17
	745	825	6	693	877	5	0,02	17
	772	878	7,5	698	952	6	0,025	16
710	761	818	4	725	855	3	0,015	17
	790	870	6	733	927	5	0,02	17
	813	927	7,5	738	1002	6	0,025	16
750	804	866	5	768	902	4	0,015	17
	835	915	6	773	977	5	0,02	17
800	857	922	5	818	962	4	0,015	17
	884	976	6	823	1037	5	0,02	17
	918	1032	7,5	828	1122	6	0,025	16
850	907	972	5	868	1012	4	0,015	18
	939	1031	6	873	1097	5	0,02	17
1000	1076	1145	6	1023	1197	5	0,015	18
1060	1132	1209	6	1083	1257	5	0,015	18
1120	1201	1278	6	1143	1337	5	0,015	18
1180	1262	1339	6	1203	1397	5	0,015	18

1.2 Capped single row deep groove ball bearings d 3 – 7 mm

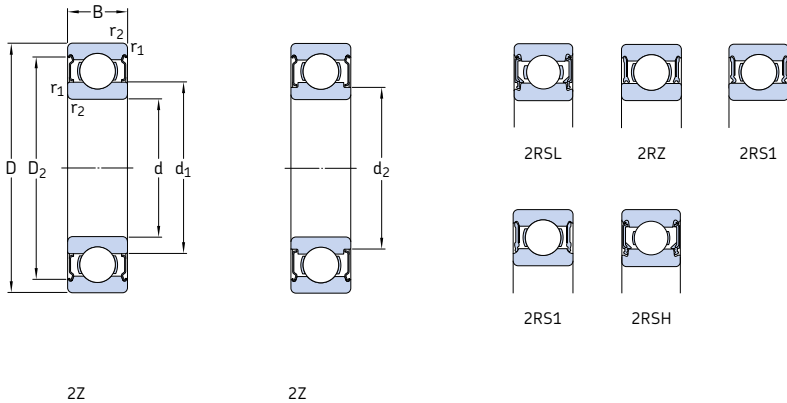

Principal dimensions			Basic load ratings dynamic static		Fatigue load limit	Speed ratings Reference speed Limiting speed ¹⁾		Mass	Designations Bearing capped on both sides one side	
d	D	B	C	C ₀	P _u	Reference speed	Limiting speed ¹⁾	kg	-	
mm			kN		kN	r/min		kg	-	
3	10	4	0,54	0,18	0,007	130 000	60 000	0,0015	623-2Z	623-Z
	10	4	0,54	0,18	0,007	-	40 000	0,0015	623-2RS1	623-RS1
4	9	3,5	0,54	0,18	0,07	140 000	70 000	0,001	628/4-2Z	-
	9	4	0,54	0,18	0,07	140 000	70 000	0,0013	638/4-2Z	-
	11	4	0,624	0,18	0,008	130 000	63 000	0,0017	619/4-2Z	-
	12	4	0,806	0,28	0,012	120 000	60 000	0,0021	604-2Z	604-Z
	13	5	0,936	0,29	0,012	110 000	53 000	0,0031	624-2Z	624-Z
	16	5	1,11	0,38	0,016	95 000	48 000	0,0054	634-2Z	634-Z
5	16	5	1,11	0,38	0,016	95 000	48 000	0,0054	634-2RZ	634-RZ
	16	5	1,11	0,38	0,016	-	28 000	0,0054	634-2RS1	634-RS1
6	11	4	0,64	0,26	0,011	120 000	60 000	0,0014	628/5-2Z	-
	11	5	0,64	0,26	0,011	120 000	60 000	0,0016	638/5-2Z	-
	13	4	0,884	0,335	0,014	110 000	56 000	0,0025	619/5-2Z	-
	16	5	1,14	0,38	0,016	104 000	55 000	0,005	E2.625-2Z	-
	16	5	1,14	0,38	0,016	95 000	48 000	0,005	* 625-2Z	* 625-Z
	19	6	2,21	0,95	0,04	90 000	47 000	0,009	E2.635-2Z	-
	19	6	2,34	0,95	0,04	80 000	40 000	0,0093	* 635-2Z	* 635-Z
	19	6	2,34	0,95	0,04	80 000	40 000	0,009	* 635-2RZ	* 635-RZ
	19	6	2,34	0,95	0,04	-	24 000	0,009	* 635-2RS1	* 635-RS1
	7	13	5	0,88	0,35	0,015	110 000	53 000	0,0026	628/6-2Z
15		5	0,884	0,27	0,011	100 000	50 000	0,0039	619/6-2Z	-
19		6	2,21	0,95	0,04	90 000	47 000	0,0084	E2.626-2Z	-
19		6	2,34	0,95	0,04	80 000	40 000	0,0084	* 626-2Z	* 626-Z
19		6	2,34	0,95	0,04	80 000	40 000	0,0084	* 626-2RSL	* 626-RSL
19		6	2,34	0,95	0,04	-	24 000	0,0084	* 626-2RSH	* 626-RSH
7	14	5	0,956	0,4	0,017	100 000	50 000	0,0031	628/7-2Z	-
	17	5	1,06	0,375	0,016	90 000	45 000	0,0049	619/7-2Z	-
	19	6	2,21	0,95	0,04	90 000	47 000	0,008	E2.607-2Z	-
	19	6	2,34	0,95	0,04	85 000	43 000	0,0084	* 607-2Z	* 607-Z
	19	6	2,34	0,95	0,04	85 000	43 000	0,0078	* 607-2RSL	* 607-RSL
	19	6	2,34	0,95	0,04	-	24 000	0,0078	* 607-2RSH	* 607-RSH

¹⁾ For bearings with only one shield or one non-contact seal (Z, RZ), the limiting speeds for open bearings are valid.

* SKF Explorer bearing

E2 → SKF Energy Efficient bearing

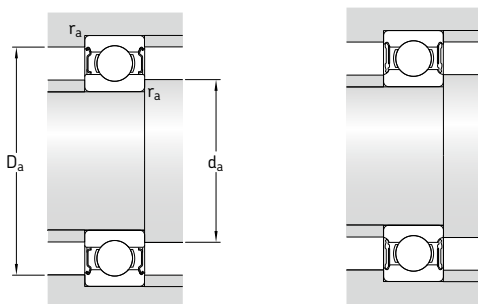

Dimensions					Abutment and fillet dimensions				Calculation factors	
d	d ₁	d ₂	D ₂	r _{1,2} min.	d _a min.	d _a max.	D _a max.	r _a max.	k _r	f ₀
mm	mm	mm	mm	mm	mm	mm	mm	mm	-	-
3	5,2	-	8,2	0,15	4,2	5,1	8,8	0,1	0,025	7,5
	5,2	-	8,2	0,15	4,2	5,1	8,8	0,1	0,025	7,5
4	5,2	-	8,1	0,1	4,6	5,1	8,4	0,1	0,015	10
	5,2	-	8,1	0,1	4,6	5,1	8,4	0,1	0,015	10
	6,1	-	9,9	0,15	4,8	5,8	10,2	0,1	0,02	6,4
	6,1	-	9,8	0,2	5,4	6	10,6	0,2	0,025	10
	6,7	-	11,2	0,2	5,8	6,6	11,2	0,2	0,025	7,3
	8,4	-	13,3	0,3	6,4	8,3	13,6	0,3	0,03	8,4
	8,4	-	13,3	0,3	6,4	8,3	13,6	0,3	0,03	8,4
5	6,8	-	9,9	0,15	5,8	6,7	10,2	0,1	0,015	11
	-	6,2	9,9	0,15	5,8	6	10,2	0,1	0,015	11
	7,5	-	11,2	0,2	6,4	7,5	11,6	0,2	0,02	11
	8,4	-	13,3	0,3	7,4	8,3	13,6	0,3	0,025	8,4
	8,4	-	13,3	0,3	7,4	8,3	13,6	0,3	0,025	8,4
	11,1	-	16,5	0,3	7,4	10,6	16,6	0,3	0,03	13
	11,1	-	16,5	0,3	7,4	10,6	16,6	0,3	0,03	13
	11,1	-	16,5	0,3	7,4	10,6	16,6	0,3	0,03	13
	11,1	-	16,5	0,3	7,4	10,6	16,6	0,3	0,03	13
	6	-	7,4	11,7	0,15	6,8	7,2	12,2	0,1	0,015
8,2		-	13	0,2	7,4	8	13,6	0,2	0,02	6,8
11,1		-	16,5	0,3	8,4	11	16,6	0,3	0,025	13
11,1		-	16,5	0,3	8,4	11	16,6	0,3	0,025	13
-		9,5	16,5	0,3	8,4	9,4	16,6	0,3	0,025	13
-		9,5	16,5	0,3	8,4	9,4	16,6	0,3	0,025	13
-		9,5	16,5	0,3	8,4	9,4	16,6	0,3	0,025	13
7	-	8,5	12,7	0,15	7,8	8	13,2	0,1	0,015	11
	10,4	-	14,3	0,3	9	9,7	15	0,3	0,02	7,3
	11,1	-	16,5	0,3	9	11	17	0,3	0,025	13
	11,1	-	16,5	0,3	9	11	17	0,3	0,025	13
	-	9,5	16,5	0,3	9	9,4	17	0,3	0,025	13
	-	9,5	16,5	0,3	9	9,4	17	0,3	0,025	13
	-	9,5	16,5	0,3	9	9,4	17	0,3	0,025	13

1.2 Capped single row deep groove ball bearings d 7 – 9 mm

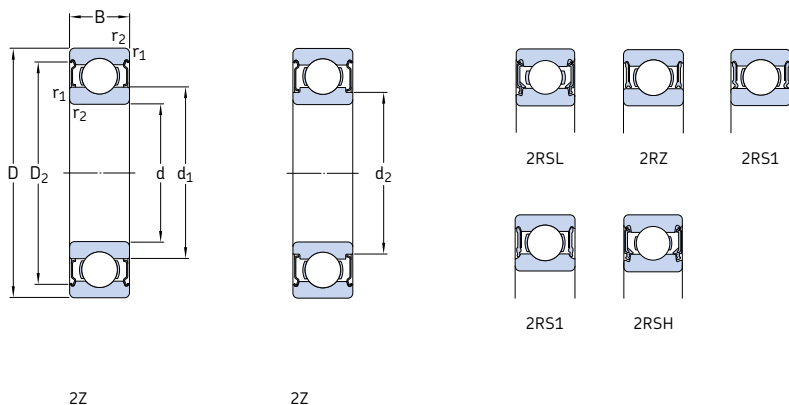

Principal dimensions			Basic load ratings dynamic static		Fatigue load limit	Speed ratings Reference speed Limiting speed ¹⁾		Mass	Designations Bearing capped on both sides	one side
d	D	B	C	C ₀	P _u	Reference speed	Limiting speed ¹⁾	kg		
mm			kN		kN	r/min			-	
7 cont.	22	7	3,32	1,37	0,06	80 000	42 000	0,013	E2.627-ZZ	-
	22	7	3,45	1,37	0,057	70 000	36 000	0,013	* 627-ZZ	* 627-Z
	22	7	3,45	1,37	0,057	70 000	36 000	0,013	* 627-2RSL	* 627-RSL
	22	7	3,45	1,37	0,057	-	22 000	0,013	* 627-2RSH	* 627-RSH
8	16	5	1,33	0,57	0,024	90 000	45 000	0,0036	628/8-2Z	-
	16	5	1,33	0,57	0,024	-	26 000	0,0036	628/8-2RS1	-
	16	6	1,33	0,57	0,024	90 000	45 000	0,0043	638/8-2Z	-
	19	6	1,46	0,465	0,02	85 000	43 000	0,0071	619/8-2Z	-
	19	6	1,46	0,465	0,02	-	24 000	0,0071	619/8-2RS1	-
	19	6	2,34	0,95	0,04	85 000	43 000	0,0072	607/8-2Z	607/8-Z
	22	7	3,32	1,37	0,06	80 000	42 000	0,012	E2.608-ZZ	-
	22	7	3,45	1,37	0,057	75 000	38 000	0,013	* 608-2Z	* 608-Z
	22	7	3,45	1,37	0,057	75 000	38 000	0,012	* 608-2RSL	* 608-RSL
	22	7	3,45	1,37	0,057	-	22 000	0,012	* 608-2RSH	* 608-RSH
	22	11	3,45	1,37	0,057	-	22 000	0,016	630/8-2RS1	-
	24	8	3,71	1,66	0,072	75 000	37 000	0,017	E2.628-ZZ	-
	24	8	3,9	1,66	0,071	63 000	32 000	0,018	* 628-2Z	* 628-Z
	24	8	3,9	1,66	0,071	63 000	32 000	0,017	* 628-2RZ	* 628-RZ
	24	8	3,9	1,66	0,071	-	19 000	0,017	* 628-2RS1	* 628-RS1
	28	6	1,33	0,57	0,024	60 000	30 000	0,03	638-2RZ	638-RZ
9	17	5	1,43	0,64	0,027	85 000	43 000	0,0043	628/9-2Z	628/9-Z
	17	5	1,43	0,64	0,027	-	24 000	0,0043	628/9-2RS1	-
	20	6	2,34	0,98	0,043	80 000	40 000	0,0076	619/9-2Z	-
	24	7	3,71	1,66	0,072	75 000	37 000	0,014	E2.609-ZZ	-
	24	7	3,9	1,66	0,071	70 000	34 000	0,015	* 609-2Z	* 609-Z
	24	7	3,9	1,66	0,071	70 000	34 000	0,014	* 609-2RSL	* 609-RSL
	24	7	3,9	1,66	0,071	-	19 000	0,014	* 609-2RSH	* 609-RSH
	26	8	4,62	1,93	0,08	70 000	36 000	0,02	E2.629-ZZ	-
	26	8	4,75	1,96	0,083	60 000	30 000	0,021	* 629-2Z	* 629-Z
	26	8	4,75	1,96	0,083	60 000	30 000	0,02	* 629-2RSL	* 629-RSL
	26	8	4,75	1,96	0,083	-	19 000	0,02	* 629-2RSH	* 629-RSH

¹⁾ For bearings with only one shield or one non-contact seal (Z, RZ), the limiting speeds for open bearings are valid.

* SKF Explorer bearing

E2 → SKF Energy Efficient bearing

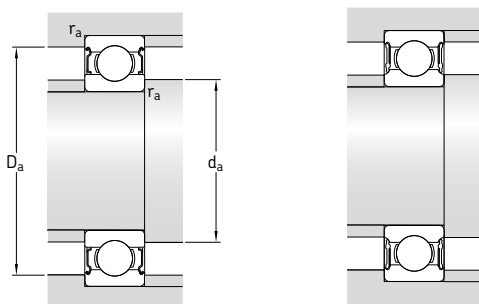

Dimensions

Abutment and fillet dimensions

Calculation factors

d	d ₁ ~	d ₂ ~	D ₂ ~	r _{1,2} min.	d _a min.	d _a max.	D _a max.	r _a max.	k _r	f ₀
mm	mm								-	
7 cont.	12,1	-	19,2	0,3	9,4	12,1	19,6	0,3	0,025	12
	12,1	-	19,2	0,3	9,4	12,1	19,6	0,3	0,025	12
	-	10,5	19,2	0,3	9,4	10,5	19,6	0,3	0,025	12
	-	10,5	19,2	0,3	9,4	10,5	19,6	0,3	0,025	12
8	10,1	-	14,2	0,2	9,4	10	14,6	0,2	0,015	11
	10,1	-	14,2	0,2	9,4	9,4	14,6	0,2	0,015	11
	-	9,6	14,2	0,2	9,4	9,5	14,6	0,2	0,015	11
	-	9,8	16,7	0,3	9,5	9,8	17	0,3	0,02	6,6
	-	9,8	16,7	0,3	9,5	9,8	17	0,3	0,02	6,6
	11,1	-	16,5	0,3	10	11	17	0,3	0,025	13
	12,1	-	19,2	0,3	10	12	20	0,3	0,025	12
	12,1	-	19,2	0,3	10	12	20	0,3	0,025	12
	-	10,5	19,2	0,3	10	10,5	20	0,3	0,025	12
	-	10,5	19,2	0,3	10	10,5	20	0,3	0,025	12
	11,8	-	19	0,3	10	11,7	20	0,3	0,025	12
	14,4	-	21,2	0,3	10,4	14,4	21,6	0,3	0,025	13
	14,4	-	21,2	0,3	10,4	14,4	21,6	0,3	0,025	13
	14,4	-	21,2	0,3	10,4	14,4	21,6	0,3	0,025	13
	14,4	-	21,2	0,3	10,4	14,4	21,6	0,3	0,025	13
	14,8	-	22,6	0,3	10,4	14,7	25,6	0,3	0,03	12
9	-	10,7	15,2	0,2	10,4	10,5	15,6	0,2	0,015	11
	-	10,7	15,2	0,2	10,4	10,5	15,6	0,2	0,015	11
	11,6	-	17,5	0,3	11	11,5	18	0,3	0,02	12
	14,4	-	21,2	0,3	11	14,3	22	0,3	0,025	13
	14,4	-	21,2	0,3	11	14,3	22	0,3	0,025	13
	-	12,8	21,2	0,3	11	12,5	22	0,3	0,025	13
	-	12,8	21,2	0,3	11	12,5	22	0,3	0,025	13
	14,8	-	22,6	0,3	11,4	14,7	23,6	0,3	0,025	12
	14,8	-	22,6	0,3	11,4	14,7	23,6	0,3	0,025	12
	-	13	22,6	0,3	11,4	12,5	23,6	0,3	0,025	12
	-	13	22,6	0,3	11,4	12,5	23,6	0,3	0,025	12

1.2 Capped single row deep groove ball bearings d 10 – 12 mm

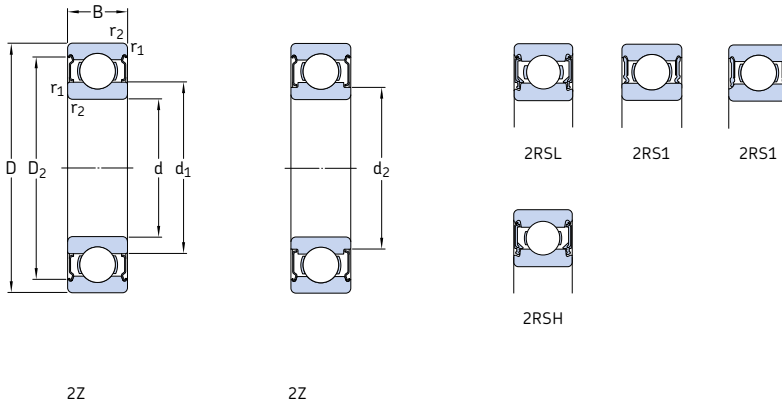

Principal dimensions			Basic load ratings dynamic static		Fatigue load limit	Speed ratings Reference speed Limiting speed ¹⁾		Mass	Designations Bearing capped on both sides one side	
d	D	B	C	C ₀	P _u	Reference speed	Limiting speed ¹⁾	kg	-	
mm			kN		kN	r/min		kg	-	
10	19	5	1,72	0,83	0,036	80 000	38 000	0,0055	61800-2Z	
	19	5	1,72	0,83	0,036	-	22 000	0,0055	61800-2RS1	
	22	6	2,7	1,27	0,054	70 000	36 000	0,01	61900-2Z	
	22	6	2,7	1,27	0,054	-	20 000	0,01	61900-2RS1	
	26	8	4,62	1,93	0,08	70 000	36 000	0,019	E2.6000-2Z	
	26	8	4,75	1,96	0,083	67 000	34 000	0,02	* 6000-2Z	
	26	8	4,75	1,96	0,083	67 000	34 000	0,019	* 6000-2RSL	
	26	8	4,75	1,96	0,083	-	19 000	0,019	* 6000-2RSH	
	26	12	4,62	1,96	0,083	-	19 000	0,025	63000-2RS1	
	28	8	5,07	2,36	0,1	60 000	30 000	0,026	16100-2Z	
	30	9	5,07	2,32	0,098	61 000	32 000	0,032	E2.6200-2Z	
	30	9	5,4	2,36	0,1	56 000	28 000	0,034	* 6200-2Z	
30	9	5,4	2,36	0,1	56 000	28 000	0,032	* 6200-2RSL		
30	9	5,4	2,36	0,1	-	17 000	0,032	* 6200-2RSH		
30	14	5,07	2,36	0,1	-	17 000	0,04	62200-2RS1		
35	11	8,32	3,4	0,143	55 000	29 000	0,053	E2.6300-2Z		
35	11	8,52	3,4	0,143	50 000	26 000	0,055	* 6300-2Z		
35	11	8,52	3,4	0,143	50 000	26 000	0,053	* 6300-2RSL		
35	11	8,52	3,4	0,143	-	15 000	0,053	* 6300-2RSH		
35	17	8,06	3,4	0,143	-	15 000	0,06	62300-2RS1		
12	21	5	1,74	0,915	0,039	70 000	36 000	0,0063	61801-2Z	
	21	5	1,74	0,915	0,039	-	20 000	0,0063	61801-2RS1	
	24	6	2,91	1,46	0,062	67 000	32 000	0,011	61901-2Z	
	24	6	2,91	1,46	0,062	-	19 000	0,011	61901-2RS1	
	28	8	5,07	2,32	0,098	66 000	33 000	0,022	E2.6001-2Z	
	28	8	5,4	2,36	0,1	60 000	30 000	0,022	* 6001-2Z	
	28	8	5,4	2,36	0,1	60 000	30 000	0,021	* 6001-2RSL	
	28	8	5,4	2,36	0,1	-	17 000	0,021	* 6001-2RSH	
	28	12	5,07	2,36	0,1	-	17 000	0,029	63001-2RS1	
	30	8	5,07	2,36	0,1	60 000	30 000	0,028	16101-2Z	
	30	8	5,07	2,36	0,1	-	16 000	0,028	16101-2RS1	

¹⁾ For bearings with only one shield or one non-contact seal (Z, RZ), the limiting speeds for open bearings are valid.

* SKF Explorer bearing

E2 → SKF Energy Efficient bearing

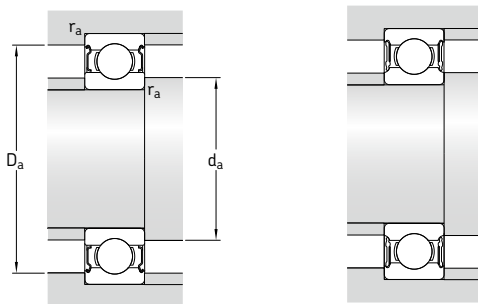

Dimensions					Abutment and fillet dimensions				Calculation factors	
d	d ₁	d ₂	D ₂	r _{1,2} min.	d _a min.	d _a max.	D _a max.	r _a max.	k _r	f ₀
mm	mm	mm	mm	mm	mm	mm	mm	mm	-	-
10	12,7	-	17,2	0,3	12	12,5	17	0,3	0,015	15
	-	11,8	17,2	0,3	11,8	11,8	17	0,3	0,015	15
	13,9	-	19,4	0,3	12	12,9	20	0,3	0,02	14
	-	13,2	19,4	0,3	12	12	20	0,3	0,02	14
	14,8	-	22,6	0,3	12	14,7	24	0,3	0,025	12
	14,8	-	22,6	0,3	12	14,7	24	0,3	0,025	12
	-	13	22,6	0,3	12	12,5	24	0,3	0,025	12
	-	13	22,6	0,3	12	12,5	24	0,3	0,025	12
	14,8	-	22,6	0,3	12	14,7	24	0,3	0,025	12
	17	-	24,8	0,3	14,2	16,6	23,8	0,3	0,025	13
	17	-	24,8	0,6	14,2	16,9	25,8	0,6	0,025	13
	17	-	24,8	0,6	14,2	16,9	25,8	0,6	0,025	13
	-	15,2	24,8	0,6	14,2	15	25,8	0,6	0,025	13
	-	15,2	24,8	0,6	14,2	15	25,8	0,6	0,025	13
	17	-	24,8	0,6	14,2	16,9	25,8	0,6	0,025	13
	17,5	-	28,7	0,6	14,2	17,4	30,8	0,6	0,03	11
	17,5	-	28,7	0,6	14,2	17,4	30,8	0,6	0,03	11
	-	15,7	28,7	0,6	14,2	15,5	30,8	0,6	0,03	11
	-	15,7	28,7	0,6	14,2	15,5	30,8	0,6	0,03	11
	17,5	-	28,7	0,6	14,2	17,4	30,8	0,6	0,03	11
12	14,8	-	19,2	0,3	14	14,7	19	0,3	0,015	13
	-	13,8	19,2	0,3	13,6	13,8	19	0,3	0,015	13
	16	-	21,4	0,3	14	15,8	22	0,3	0,02	15
	-	15,3	21,4	0,3	14	15,2	22	0,3	0,02	15
	17	-	24,8	0,3	14	16,9	26	0,3	0,025	13
	17	-	24,8	0,3	14	16,9	26	0,3	0,025	13
	-	15,2	24,8	0,3	14	15	26	0,3	0,025	13
	-	15,2	24,8	0,3	14	15	26	0,3	0,025	13
	17	-	24,8	0,3	14	16,9	26	0,3	0,025	13
	17	-	24,8	0,3	14,4	16,6	27,6	0,3	0,025	13
	16,7	-	24,8	0,3	14,4	16,6	27,6	0,3	0,025	13

1.2 Capped single row deep groove ball bearings d 12 – 15 mm

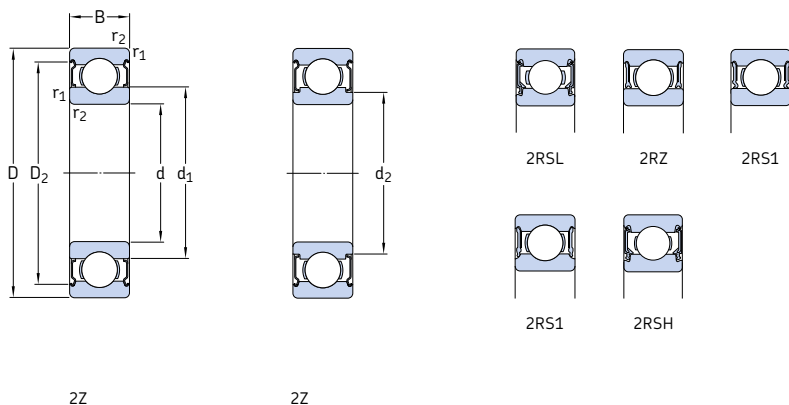

Principal dimensions			Basic load ratings dynamic static		Fatigue load limit	Speed ratings Reference speed Limiting speed ¹⁾		Mass	Designations Bearing capped on both sides one side	
d	D	B	C	C ₀	P _u	Reference speed	Limiting speed ¹⁾	kg	-	-
mm			kN		kN	r/min		kg	-	-
12 cont.	32	10	7,02	3,1	0,132	55 000	29 000	0,037	E2.6201-2Z	-
	32	10	7,28	3,1	0,132	50 000	26 000	0,039	* 6201-2Z	* 6201-Z
	32	10	7,28	3,1	0,132	50 000	26 000	0,038	* 6201-2RSL	* 6201-RSL
	32	10	7,28	3,1	0,132	-	15 000	0,038	* 6201-2RSH	* 6201-RSH
	32	14	6,89	3,1	0,132	-	15 000	0,045	62201-2RS1	-
	37	12	9,95	4,15	0,176	49 000	25 000	0,06	E2.6301-2Z	-
	37	12	10,1	4,15	0,176	45 000	22 000	0,063	* 6301-2Z	* 6301-Z
	37	12	10,1	4,15	0,176	45 000	22 000	0,06	* 6301-2RSL	* 6301-RSL
	37	12	10,1	4,15	0,176	-	14 000	0,06	* 6301-2RSH	* 6301-RSH
	15	24	5	1,9	1,1	0,048	60 000	30 000	0,0074	61802-2Z
24		5	1,9	1,1	0,048	-	17 000	0,0074	61802-2RS1	-
28		7	4,36	2,24	0,095	56 000	28 000	0,016	61902-2Z	-
28		7	4,36	2,24	0,095	56 000	28 000	0,016	61902-2RZ	-
28		7	4,36	2,24	0,095	-	16 000	0,016	61902-2RS1	-
32		8	5,85	2,85	0,12	50 000	26 000	0,025	* 16002-2Z	* 16002-Z
32		9	5,53	2,75	0,118	55 000	28 000	0,03	E2.6002-2Z	-
32		9	5,85	2,85	0,12	50 000	26 000	0,032	* 6002-2Z	* 6002-Z
32		9	5,85	2,85	0,12	50 000	26 000	0,03	* 6002-2RSL	* 6002-RSL
32		9	5,85	2,85	0,12	-	14 000	0,03	* 6002-2RSH	* 6002-RSH
32		13	5,59	2,85	0,12	-	14 000	0,039	63002-2RS1	-
35		11	7,8	3,75	0,16	47 000	25 000	0,045	E2.6202-2Z	-
35		11	8,06	3,75	0,16	43 000	22 000	0,048	* 6202-2Z	* 6202-Z
35		11	8,06	3,75	0,16	43 000	22 000	0,046	* 6202-2RSL	* 6202-RSL
35		11	8,06	3,75	0,16	-	13 000	0,046	* 6202-2RSH	* 6202-RSH
35		14	7,8	3,75	0,16	-	13 000	0,054	62202-2RS1	-
42		13	11,4	5,3	0,224	41 000	21 000	0,083	E2.6302-2Z	-
42		13	11,9	5,4	0,228	38 000	19 000	0,086	* 6302-2Z	* 6302-Z
42		13	11,9	5,4	0,228	38 000	19 000	0,085	* 6302-2RSL	* 6302-RSL
42		13	11,9	5,4	0,228	-	12 000	0,085	* 6302-2RSH	* 6302-RSH
42	17	11,4	5,4	0,228	-	12 000	0,11	62302-2RS1	-	

¹⁾ For bearings with only one shield or one non-contact seal (Z, RZ), the limiting speeds for open bearings are valid.

* SKF Explorer bearing

E2 → SKF Energy Efficient bearing

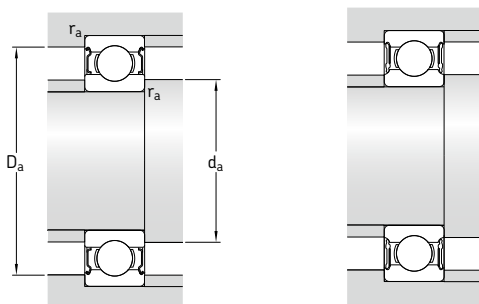

Dimensions					Abutment and fillet dimensions				Calculation factors	
d	d ₁	d ₂	D ₂	r _{1,2}	d _a	d _a	D _a	r _a	k _r	f ₀
mm	~	~	~	min.	min.	max.	max.	max.	-	
12 cont.	18,4	-	27,4	0,6	16,2	18,4	27,8	0,6	0,025	12
	18,4	-	27,4	0,6	16,2	18,4	27,8	0,6	0,025	12
	-	16,6	27,4	0,6	16,2	16,5	27,8	0,6	0,025	12
	-	16,6	27,4	0,6	16,2	16,5	27,8	0,6	0,025	12
	18,5	-	27,4	0,6	16,2	18,4	27,8	0,6	0,025	12
	19,5	-	31,5	1	17,6	19,4	31,4	1	0,03	11
	19,5	-	31,5	1	17,6	19,4	31,4	1	0,03	11
	-	17,7	31,5	1	17,6	17,6	31,4	1	0,03	11
	-	17,7	31,5	1	17,6	17,6	31,4	1	0,03	11
	15	17,8	-	22,2	0,3	17	17,8	22	0,3	0,015
17,8		-	22,2	0,3	17	17,8	22	0,3	0,015	14
18,8		-	25,3	0,3	17	18,3	26	0,3	0,02	14
18,8		-	25,3	0,3	17	18,3	26	0,3	0,02	14
18,8		-	25,3	0,3	17	18,3	26	0,3	0,02	14
20,5		-	28,2	0,3	17	20,1	30	0,3	0,02	14
20,5		-	28,2	0,3	17	20,4	30	0,3	0,025	14
20,5		-	28,2	0,3	17	20,4	30	0,3	0,025	14
-		18,7	28,2	0,3	17	18,5	30	0,3	0,025	14
-		18,7	28,2	0,3	17	18,5	30	0,3	0,025	14
20,5		-	28,2	0,3	17	20,4	30	0,3	0,025	14
21,7		-	30,4	0,6	19,2	21,6	30,8	0,6	0,025	13
21,7		-	30,4	0,6	19,2	21,6	30,8	0,6	0,025	13
-		19,4	30,4	0,6	19,2	19,4	30,8	0,6	0,025	13
-		19,4	30,4	0,6	19,2	19,4	30,8	0,6	0,025	13
21,7		-	30,4	0,6	19,2	21,6	30,8	0,6	0,025	13
23,7		-	36,3	1	20,6	23,6	36,4	1	0,03	12
23,7		-	36,3	1	20,6	23,6	36,4	1	0,03	12
-		21,1	36,3	1	20,6	21	36,4	1	0,03	12
-		21,1	36,3	1	20,6	21	36,4	1	0,03	12
23,7	-	36,3	1	20,6	23,6	36,4	1	0,03	12	

1.2 Capped single row deep groove ball bearings d 17 – 20 mm

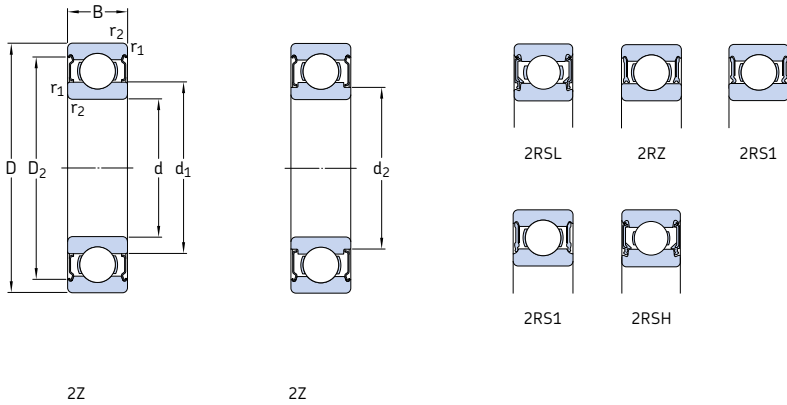

Principal dimensions			Basic load ratings dynamic static		Fatigue load limit	Speed ratings Reference speed Limiting speed ¹⁾		Mass	Designations Bearing capped on both sides	one side
d	D	B	C	C ₀	P _u	Reference speed	Limiting speed ¹⁾	kg	-	-
mm										
			kN		kN	r/min		kg	-	
17	26	5	2,03	1,27	0,054	56 000	28 000	0,0082	61803-ZZ	-
	26	5	2,03	1,27	0,054	56 000	28 000	0,0082	61803-2RZ	-
	26	5	2,03	1,27	0,054	-	16 000	0,0082	61803-2RS1	-
	30	7	4,62	2,55	0,108	50 000	26 000	0,017	61903-ZZ	-
	30	7	4,62	2,55	0,108	50 000	26 000	0,018	61903-2RZ	-
	30	7	4,62	2,55	0,108	-	14 000	0,017	61903-2RS1	-
	35	8	6,37	3,25	0,137	45 000	22 000	0,032	* 16003-ZZ	-
	35	10	5,85	3	0,127	49 000	25 000	0,039	E2.6003-ZZ	-
	35	10	6,37	3,25	0,137	45 000	22 000	0,041	* 6003-ZZ	* 6003-Z
	35	10	6,37	3,25	0,137	45 000	22 000	0,039	* 6003-2RSL	* 6003-RSL
	35	10	6,37	3,25	0,137	-	13 000	0,039	* 6003-2RSH	* 6003-RSH
	35	14	6,05	3,25	0,137	-	13 000	0,052	63003-2RS1	-
	40	12	9,56	4,75	0,2	41 000	21 000	0,065	E2.6203-ZZ	-
	40	12	9,95	4,75	0,2	38 000	19 000	0,068	* 6203-ZZ	* 6203-Z
	40	12	9,95	4,75	0,2	38 000	19 000	0,067	* 6203-2RSL	* 6203-RSL
	40	12	9,95	4,75	0,2	-	12 000	0,067	* 6203-2RSH	* 6203-RSH
	40	16	9,56	4,75	0,2	-	12 000	0,089	62203-2RS1	-
	47	14	13,8	6,55	0,275	37 000	19 000	0,12	E2.6303-ZZ	-
47	14	14,3	6,55	0,275	34 000	17 000	0,12	* 6303-ZZ	* 6303-Z	
47	14	14,3	6,55	0,275	34 000	17 000	0,12	* 6303-2RSL	* 6303-RSL	
47	14	14,3	6,55	0,275	-	11 000	0,12	* 6303-2RSH	* 6303-RSH	
47	19	13,5	6,55	0,275	-	11 000	0,16	62303-2RS1	-	
20	32	7	4,03	2,32	0,104	45 000	22 000	0,018	61804-2RZ	-
	32	7	4,03	2,32	0,104	-	13 000	0,018	61804-2RS1	-
	37	9	6,37	3,65	0,156	43 000	20 000	0,038	61904-2RZ	-
	37	9	6,37	3,65	0,156	-	12 000	0,038	61904-2RS1	-
	42	12	9,36	5	0,212	41 000	21 000	0,069	E2.6004-ZZ	-
	42	12	9,95	5	0,212	38 000	19 000	0,071	* 6004-ZZ	* 6004-Z
	42	12	9,95	5	0,212	38 000	19 000	0,067	* 6004-2RSL	* 6004-RSL
	42	12	9,95	5	0,212	-	11 000	0,067	* 6004-2RSH	* 6004-RSH
	42	16	9,36	5	0,212	-	11 000	0,086	63004-2RS1	-

¹⁾ For bearings with only one shield or one non-contact seal (Z, RZ), the limiting speeds for open bearings are valid.

* SKF Explorer bearing

E2 → SKF Energy Efficient bearing

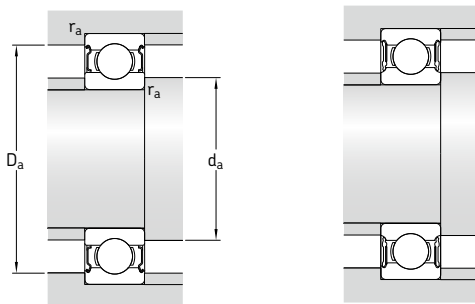

Dimensions					Abutment and fillet dimensions				Calculation factors	
d	d ₁	d ₂	D ₂	r _{1,2} min.	d _a min.	d _a max.	D _a max.	r _a max.	k _r	f ₀
mm	~	~	~		mm				-	
17	19,8	-	24,2	0,3	19	19,6	24	0,3	0,015	14
	19,8	-	24,2	0,3	19	19,6	24	0,3	0,015	14
	-	18,8	24,2	0,3	18	18,6	24	0,3	0,015	14
	20,4	-	27,7	0,3	19	20,3	28	0,3	0,02	15
	20,4	-	27,7	0,3	19	20,3	28	0,3	0,02	15
	-	19,4	27,7	0,3	19	19,3	28	0,3	0,02	15
	23	-	31,2	0,3	19	22,6	33	0,3	0,02	14
	23	-	31,2	0,3	19	22,9	33	0,3	0,025	14
	23	-	31,2	0,3	19	22,9	33	0,3	0,025	14
	-	20,7	31,2	0,3	19	20,5	33	0,3	0,025	14
	-	20,7	31,2	0,3	19	20,5	33	0,3	0,025	14
	23	-	31,2	0,3	19	22,9	33	0,3	0,025	14
	24,5	-	35	0,6	21,2	24,4	35,8	0,6	0,025	13
	24,5	-	35	0,6	21,2	24,4	35,8	0,6	0,025	13
	-	22,2	35	0,6	21,2	22	35,8	0,6	0,025	13
	-	22,2	35	0,6	21,2	22	35,8	0,6	0,025	13
	24,5	-	35	0,6	21,2	24,4	35,8	0,6	0,025	13
26,5	-	39,6	1	22,6	26,4	41,4	1	0,03	12	
26,5	-	39,6	1	22,6	26,4	41,4	1	0,03	12	
-	24	39,6	1	22,6	23,5	41,4	1	0,03	12	
-	24	39,6	1	22,6	23,5	41,4	1	0,03	12	
26,5	-	39,6	1	22,6	26,4	41,4	1	0,03	12	
20	23,8	-	29,4	0,3	22	23,6	30	0,3	0,015	15
	23,8	-	29,4	0,3	22	23,6	30	0,3	0,015	15
	25,5	-	32,7	0,3	22	25,5	35	0,3	0,02	15
	-	23,1	32,7	0,3	22	23	35	0,3	0,02	15
	27,2	-	37,2	0,6	23,2	27,1	38,8	0,6	0,025	14
	27,2	-	37,2	0,6	23,2	27,1	38,8	0,6	0,025	14
	-	24,9	37,2	0,6	23,2	24,5	38,8	0,6	0,025	14
	-	24,9	37,2	0,6	23,2	24,5	38,8	0,6	0,025	14
	27,2	-	37,2	0,6	23,2	27,1	38,8	0,6	0,025	14
	27,2	-	37,2	0,6	23,2	27,1	38,8	0,6	0,025	14

1.2 Capped single row deep groove ball bearings d 20 – 25 mm

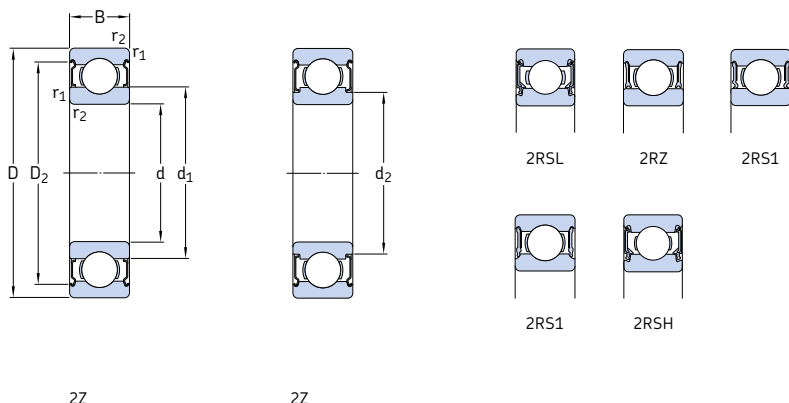

Principal dimensions	Basic load ratings		Fatigue load limit	Speed ratings		Mass	Designations				
	dynamic	static		Reference speed	Limiting speed ¹⁾		Bearing capped on both sides	one side			
d	D	B	C	C ₀	P _u						
mm			kN		kN	r/min	kg	–			
20 cont.	47	14	12,7	6,55	0,28	35 000	19 000	0,11	E2.6204-ZZ	–	
	47	14	13,5	6,55	0,28	32 000	17 000	0,11	* 6204-ZZ	* 6204-Z	
	47	14	13,5	6,55	0,28	32 000	17 000	0,11	* 6204-2RSL	* 6204-RSL	
	47	14	13,5	6,55	0,28	–	10 000	0,11	* 6204-2RSH	* 6204-RSH	
	47	18	12,7	6,55	0,28	–	10 000	0,13	62204-2RS1	–	
	52	15	16,3	7,8	0,34	34 000	18 000	0,15	E2.6304-ZZ	–	
	52	15	16,8	7,8	0,335	30 000	15 000	0,15	* 6304-ZZ	* 6304-Z	
	52	15	16,8	7,8	0,335	30 000	15 000	0,15	* 6304-2RSL	* 6304-RSL	
	52	15	16,8	7,8	0,335	–	9 500	0,15	* 6304-2RSH	* 6304-RSH	
	52	21	15,9	7,8	0,335	–	9 500	0,21	62304-2RS1	–	
	22	50	14	14	7,65	0,325	–	9 000	0,12	62/22-2RS1	–
	25	37	7	4,36	2,6	0,125	38 000	19 000	0,022	61805-2RZ	–
37		7	4,36	2,6	0,125	–	11 000	0,022	61805-2RS1	–	
42		9	7,02	4,3	0,193	36 000	18 000	0,045	61905-2RZ	–	
42		9	7,02	4,3	0,193	–	10 000	0,045	61905-2RS1	–	
47		12	11,1	6,1	0,26	35 000	18 000	0,08	E2.6005-ZZ	–	
47		12	11,9	6,55	0,275	32 000	16 000	0,083	* 6005-ZZ	* 6005-Z	
47		12	11,9	6,55	0,275	32 000	16 000	0,08	* 6005-2RSL	* 6005-RSL	
47		12	11,9	6,55	0,275	–	9 500	0,08	* 6005-2RSH	* 6005-RSH	
47		16	11,2	6,55	0,275	–	9 500	0,11	63005-2RS1	–	
52		15	13,8	7,65	0,325	30 000	16 000	0,13	E2.6205-ZZ	–	
52		15	14,8	7,8	0,335	28 000	14 000	0,13	* 6205-ZZ	* 6205-Z	
52		15	14,8	7,8	0,335	28 000	14 000	0,13	* 6205-2RSL	* 6205-RSL	
52	15	14,8	7,8	0,335	–	8 500	0,13	* 6205-2RSH	* 6205-RSH		
52	18	14	7,8	0,335	–	8 500	0,15	62205-2RS1	–		
62	17	22,9	11,6	0,49	28 000	15 000	0,23	E2.6305-ZZ	–		
62	17	23,4	11,6	0,49	24 000	13 000	0,23	* 6305-ZZ	* 6305-Z		
62	17	23,4	11,6	0,49	24 000	13 000	0,23	* 6305-2RZ	* 6305-RZ		
62	17	23,4	11,6	0,49	–	7 500	0,23	* 6305-2RS1	* 6305-RS1		
62	24	22,5	11,6	0,49	–	7 500	0,32	62305-2RS1	–		

¹⁾ For bearings with only one shield or one non-contact seal (Z, RZ), the limiting speeds for open bearings are valid.

* SKF Explorer bearing

E2 → SKF Energy Efficient bearing

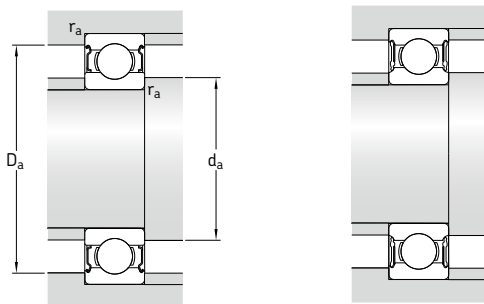

Dimensions					Abutment and fillet dimensions				Calculation factors	
d	d ₁	d ₂	D ₂	r _{1,2} min.	d _a min.	d _a max.	D _a max.	r _a max.	k _r	f ₀
mm	~	~	~		mm				-	
20 cont.	28,8	-	40,6	1	25,6	28,7	41,4	1	0,025	13
	28,8	-	40,6	1	25,6	28,7	41,4	1	0,025	13
	-	26,3	40,6	1	25,6	26	41,4	1	0,025	13
	-	26,3	40,6	1	25,6	26	41,4	1	0,025	13
	28,8	-	40,6	1	25,6	28,7	41,4	1	0,025	13
	30,3	-	44,8	1,1	27	30,3	45	1	0,03	12
	30,3	-	44,8	1,1	27	30,3	45	1	0,03	12
	-	27,2	44,8	1,1	27	27	45	1	0,03	12
	-	27,2	44,8	1,1	27	27	45	1	0,03	12
	30,3	-	44,8	1,1	27	30,3	45	1	0,03	12
22	32,2	-	44	1	27,6	32	44,4	1	0,025	14
25	28,5	-	34,2	0,3	27	28,4	35	0,3	0,015	14
	-	27,4	34,2	0,3	27	27,3	35	0,3	0,015	14
	30,2	-	37,7	0,3	27	30,1	40	0,3	0,02	15
	30,2	-	37,7	0,3	27	30,1	40	0,3	0,02	15
	32	-	42,2	0,6	28,2	31,9	43,8	0,6	0,025	14
	32	-	42,2	0,6	28,2	31,9	43,8	0,6	0,025	14
	-	29,7	42,2	0,6	28,2	29,5	43,8	0,6	0,025	14
	-	29,7	42,2	0,6	28,2	29,5	43,8	0,6	0,025	14
	32	-	42,2	0,6	29,2	31,9	43,8	0,6	0,025	14
	34,3	-	46,3	1	30,6	34,3	46,4	1	0,025	14
	34,3	-	46,3	1	30,6	34,3	46,4	1	0,025	14
	-	31,8	46,3	1	30,6	31,5	46,4	1	0,025	14
	-	31,8	46,3	1	30,6	31,5	46,4	1	0,025	14
	34,4	-	46,3	1	30,6	34,3	46,4	1	0,025	14
36,6	-	52,7	1,1	32	36,5	55	1	0,03	12	
36,6	-	52,7	1,1	32	36,5	55	1	0,03	12	
36,6	-	52,7	1,1	32	36,5	55	1	0,03	12	
36,6	-	52,7	1,1	32	36,5	55	1	0,03	12	
36,6	-	52,7	1,1	32	36,5	55	1	0,03	12	

1.2 Capped single row deep groove ball bearings d 30 – 35 mm

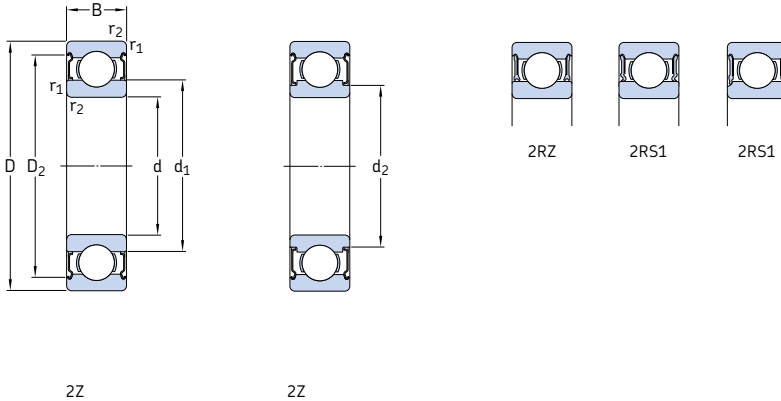

Principal dimensions			Basic load ratings dynamic static		Fatigue load limit	Speed ratings Reference speed Limiting speed ¹⁾		Mass	Designations Bearing capped on both sides one side	
d	D	B	C	C ₀	P _u			kg	-	
mm			kN		kN	r/min				
30	42	7	4,49	2,9	0,146	32 000	16 000	0,025	61806-2RZ	-
	42	7	4,49	2,9	0,146	-	9 500	0,025	61806-2RS1	-
	47	9	7,28	4,55	0,212	30 000	15 000	0,05	61906-2RZ	-
	47	9	7,28	4,55	0,212	-	8 500	0,05	61906-2RS1	-
	55	13	12,7	7,35	0,31	30 000	15 000	0,12	E2.6006-2Z	-
	55	13	13,8	8,3	0,355	28 000	14 000	0,12	* 6006-2Z	* 6006-Z
	55	13	13,8	8,3	0,355	28 000	14 000	0,12	* 6006-2RZ	* 6006-RZ
	55	13	13,8	8,3	0,355	-	8 000	0,12	* 6006-2RS1	* 6006-RS1
	55	19	13,3	8,3	0,355	-	8 000	0,17	63006-2RS1	-
	62	16	19,5	11,2	0,475	26 000	14 000	0,2	E2.6206-2Z	-
	62	16	20,3	11,2	0,475	24 000	12 000	0,2	* 6206-2Z	* 6206-Z
	62	16	20,3	11,2	0,475	24 000	12 000	0,2	* 6206-2RZ	* 6206-RZ
62	16	20,3	11,2	0,475	-	7 500	0,2	* 6206-2RS1	* 6206-RS1	
62	20	19,5	11,2	0,475	-	7 500	0,25	62206-2RS1	-	
35	72	19	28,6	16	0,67	22 000	12 000	0,36	E2.6306-2Z	-
	72	19	29,6	16	0,67	20 000	11 000	0,36	* 6306-2Z	* 6306-Z
	72	19	29,6	16	0,67	20 000	11 000	0,36	* 6306-2RZ	* 6306-RZ
	72	19	29,6	16	0,67	-	6 300	0,36	* 6306-2RS1	* 6306-RS1
	72	27	28,1	16	0,67	-	6 300	0,5	62306-2RS1	-
	47	7	4,36	3,35	0,14	30 000	15 000	0,03	61807-2RZ	-
	47	7	4,36	3,35	0,14	-	8 500	0,022	61807-2RS1	-
	55	10	10,8	7,8	0,325	26 000	13 000	0,08	61907-2RZ	-
	55	10	10,8	7,8	0,325	-	7 500	0,08	61907-2RS1	-
	62	14	16,8	10,2	0,44	24 000	12 000	0,16	* 6007-2Z	* 6007-Z
	62	14	16,8	10,2	0,44	24 000	12 000	0,16	* 6007-2RZ	* 6007-RZ
	62	14	16,8	10,2	0,44	-	7 000	0,16	* 6007-2RS1	* 6007-RS1
62	20	15,9	10,2	0,44	-	7 000	0,23	63007-2RS1	-	
72	17	25,5	15,3	0,64	22 000	12 000	0,3	E2.6207-2Z	-	
72	17	27	15,3	0,655	20 000	10 000	0,3	* 6207-2Z	* 6207-Z	
72	17	27	15,3	0,655	-	6 300	0,3	* 6207-2RS1	* 6207-RS1	
72	23	25,5	15,3	0,655	-	6 300	0,4	62207-2RS1	-	

¹⁾ For bearings with only one shield or one non-contact seal (Z, RZ), the limiting speeds for open bearings are valid.

* SKF Explorer bearing

E2 → SKF Energy Efficient bearing

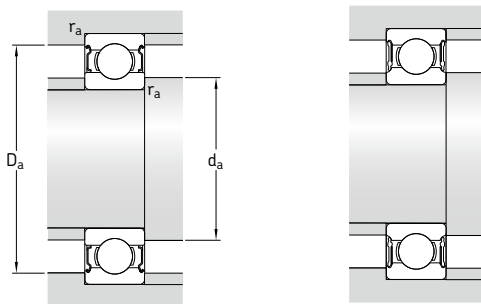

Dimensions

Abutment and fillet dimensions

Calculation factors

d	d ₁ ~	d ₂ ~	D ₂ ~	r _{1,2} min.	d _a min.	d _a max.	D _a max.	r _a max.	k _r	f ₀
mm					mm				-	
30	33,7	-	39,4	0,3	32	33,6	40	0,3	0,015	14
	-	32,6	39,4	0,3	32	32,5	40	0,3	0,015	14
	35,2	-	42,7	0,3	32	35,1	45	0,3	0,02	14
	-	34,2	42,7	0,3	32	34	45	0,3	0,02	14
	38,2	-	49	1	34,6	38,1	50,4	1	0,025	15
	38,2	-	49	1	34,6	38,1	50,4	1	0,025	15
	38,2	-	49	1	34,6	38,1	50,4	1	0,025	15
	38,2	-	49	1	34,6	38,1	50,4	1	0,025	15
	38,2	-	49	1	34,6	38,1	50,4	1	0,025	15
	40,3	-	54,1	1	35,6	40,3	56,4	1	0,025	14
	40,3	-	54,1	1	35,6	40,3	56,4	1	0,025	14
	40,3	-	54,1	1	35,6	40,3	56,4	1	0,025	14
	40,3	-	54,1	1	35,6	40,3	56,4	1	0,025	14
	40,3	-	54,1	1	35,6	40,3	56,4	1	0,025	14
	44,6	-	61,9	1,1	37	44,5	65	1	0,03	13
44,6	-	61,9	1,1	37	44,5	65	1	0,03	13	
44,6	-	61,9	1,1	37	44,5	65	1	0,03	13	
44,6	-	61,9	1,1	37	44,5	65	1	0,03	13	
44,6	-	61,9	1,1	37	44,5	65	1	0,03	13	
35	38,2	-	44,4	0,3	37	38	45	0,3	0,015	14
	38,2	-	44,4	0,3	37	38	45	0,3	0,015	14
	42,2	-	52,2	0,6	38,2	41,5	51,8	0,6	0,02	16
	42,2	-	52,2	0,6	38,2	41,5	51,8	0,6	0,02	16
	43,7	-	55,7	1	39,6	43,7	57,4	1	0,025	15
	43,7	-	55,7	1	39,6	43,7	57,4	1	0,025	15
	43,7	-	55,7	1	39,6	43,7	57,4	1	0,025	15
	43,7	-	55,7	1	39,6	43,7	57,4	1	0,025	15
	46,9	-	62,7	1,1	42	46,8	65	1	0,025	14
	46,9	-	62,7	1,1	42	46,8	65	1	0,025	14
	46,9	-	62,7	1,1	42	46,8	65	1	0,025	14
	46,9	-	62,7	1,1	42	46,8	65	1	0,025	14

1.2 Capped single row deep groove ball bearings d 35 – 45 mm

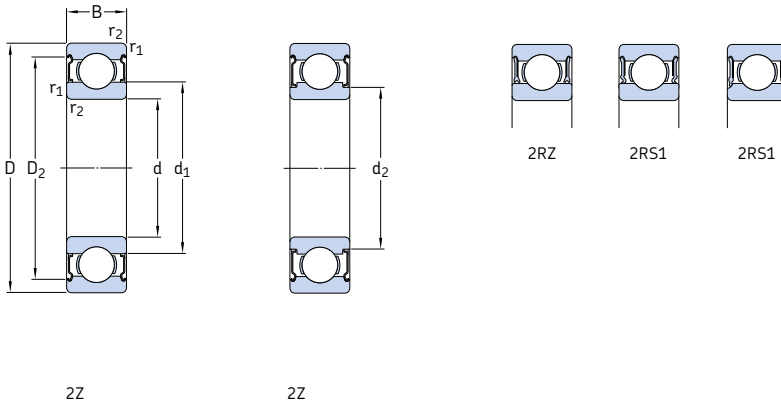

Principal dimensions			Basic load ratings dynamic static		Fatigue load limit	Speed ratings Reference speed Limiting speed ¹⁾		Mass	Designations Bearing capped on both sides	one side
d	D	B	C	C ₀	P _u			kg		
mm			kN		kN	r/min			-	
35 cont.	80	21	33,8	19	0,815	20 000	11 000	0,48	E2.6307-ZZ	-
	80	21	35,1	19	0,815	19 000	9 500	0,48	* 6307-ZZ	* 6307-Z
	80	21	35,1	19	0,815	-	6 000	0,47	* 6307-2RS1	* 6307-RS1
	80	31	33,2	19	0,815	-	6 000	0,68	62307-2RS1	-
40	52	7	4,49	3,75	0,16	26 000	13 000	0,034	61808-2RZ	-
	52	7	4,49	3,75	0,16	-	7 500	0,034	61808-2RS1	-
	62	12	13,8	10	0,425	24 000	12 000	0,12	61908-2RZ	-
	62	12	13,8	10	0,425	-	6 700	0,12	61908-2RS1	-
	68	15	17,8	11	0,49	22 000	11 000	0,2	* 6008-2Z	* 6008-Z
	68	15	17,8	11	0,49	22 000	11 000	0,2	* 6008-2RZ	* 6008-RZ
	68	15	17,8	11	0,49	-	6 300	0,2	* 6008-2RS1	* 6008-RS1
	68	21	16,8	11	0,49	-	6 300	0,27	63008-2RS1	-
	80	18	30,7	18,6	0,78	20 000	11 000	0,38	E2.6208-ZZ	-
	80	18	32,5	19	0,8	18 000	9 000	0,38	* 6208-2Z	* 6208-Z
	80	18	32,5	19	0,8	18 000	9 000	0,38	* 6208-2RZ	* 6208-RZ
	80	18	32,5	19	0,8	-	5 600	0,38	* 6208-2RS1	* 6208-RS1
	80	23	30,7	19	0,8	-	5 600	0,47	62208-2RS1	-
	90	23	41	24	1,02	18 000	10 000	0,65	E2.6308-ZZ	-
	90	23	42,3	24	1,02	17 000	8 500	0,65	* 6308-2Z	* 6308-Z
	90	23	42,3	24	1,02	17 000	8 500	0,65	* 6308-2RZ	* 6308-RZ
90	23	42,3	24	1,02	-	5 000	0,65	* 6308-2RS1	* 6308-RS1	
90	33	41	24	1,02	-	5 000	0,92	62308-2RS1	-	
45	58	7	6,63	6,1	0,26	22 000	11 000	0,04	61809-2RZ	-
	58	7	6,63	6,1	0,26	-	6 700	0,04	61809-2RS1	-
	68	12	14	10,8	0,465	20 000	10 000	0,14	61909-2RZ	-
	68	12	14	10,8	0,465	-	6 000	0,14	61909-2RS1	-
	75	16	22,1	14,6	0,64	20 000	10 000	0,25	* 6009-2Z	* 6009-Z
	75	16	22,1	14,6	0,64	-	5 600	0,25	* 6009-2RS1	* 6009-RS1
	75	23	20,8	14,6	0,64	-	5 600	0,36	63009-2RS1	-

¹⁾ For bearings with only one shield or one non-contact seal (Z, RZ), the limiting speeds for open bearings are valid.

* SKF Explorer bearing

E2 → SKF Energy Efficient bearing

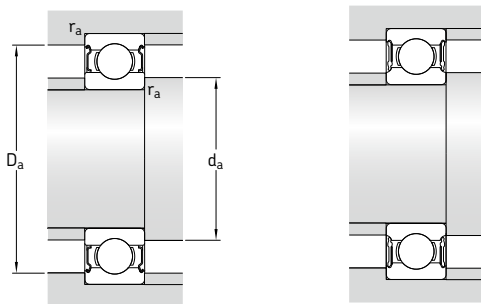

Dimensions					Abutment and fillet dimensions				Calculation factors	
d	d ₁	d ₂	D ₂	r _{1,2}	d _a	d _a	D _a	r _a	k _r	f ₀
mm	~	~	~	min.	mm	max.	max.	max.	-	-
35 cont.	49,5	-	69,2	1,5	44	49,5	71	1,5	0,03	13
	49,5	-	69,2	1,5	44	49,5	71	1,5	0,03	13
	49,5	-	69,2	1,5	44	49,5	71	1,5	0,03	13
	49,5	-	69,2	1,5	44	49,5	71	1,5	0,03	13
40	43,2	-	49,3	0,3	42	43	50	0,3	0,015	15
	-	42,1	49,3	0,3	42	42	50	0,3	0,015	15
	46,9	-	57,3	0,6	43,2	46,8	58,8	0,6	0,02	16
	46,9	-	57,3	0,6	43,2	46,8	58,8	0,6	0,02	16
	49,2	-	61,1	1	44,6	49,2	63,4	1	0,025	15
	49,2	-	61,1	1	44,6	49,2	63,4	1	0,025	15
	49,2	-	61,1	1	44,6	49,2	63,4	1	0,025	15
	49,2	-	61,1	1	44,6	49,2	63,4	1	0,025	15
	52,6	-	69,8	1,1	47	52,5	73	1	0,025	14
	52,6	-	69,8	1,1	47	52,5	73	1	0,025	14
	52,6	-	69,8	1,1	47	52,5	73	1	0,025	14
	52,6	-	69,8	1,1	47	52,5	73	1	0,025	14
	52,6	-	69,8	1,1	47	52,5	73	1	0,025	14
	56,1	-	77,7	1,5	49	56	81	1,5	0,03	13
	56,1	-	77,7	1,5	49	56	81	1,5	0,03	13
	56,1	-	77,7	1,5	49	56	81	1,5	0,03	13
56,1	-	77,7	1,5	49	56	81	1,5	0,03	13	
56,1	-	77,7	1,5	49	56	81	1,5	0,03	13	
45	49,1	-	55,4	0,3	47	49	56	0,3	0,015	17
	49,1	-	55,4	0,3	47	49	56	0,3	0,015	17
	52,4	-	62,8	0,6	48,2	52,3	64,8	0,6	0,02	16
	52,4	-	62,8	0,6	48,2	52,3	64,8	0,6	0,02	16
	54,7	-	67,8	1	50,8	54,7	69,2	1	0,025	15
	54,7	-	67,8	1	50,8	54,7	69,2	1	0,025	15
	54,7	-	67,8	1	50,8	54,7	69,2	1	0,025	15

1.2 Capped single row deep groove ball bearings d 45 – 55 mm

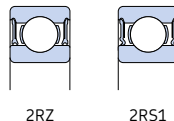
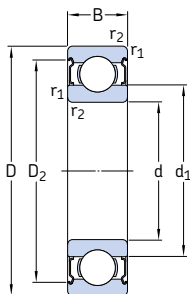

2Z

Principal dimensions			Basic load ratings dynamic static		Fatigue load limit	Speed ratings Reference speed Limiting speed ¹⁾		Mass	Designations Bearing capped on both sides one side		
d	D	B	C	C ₀	P _u	Reference speed	Limiting speed ¹⁾	kg	-	-	
mm			kN		kN	r/min		kg	-	-	
45 cont.	85	19	32,5	20,4	0,865	18 000	10 000	0,43	E2.6209-ZZ	-	
	85	19	35,1	21,6	0,915	17 000	8 500	0,43	* 6209-ZZ	* 6209-Z	
	85	19	35,1	21,6	0,915	-	5 000	0,43	* 6209-2RS1	* 6209-RS1	
	85	23	33,2	21,6	0,915	-	5 000	0,51	62209-2RS1	-	
	100	25	52,7	31,5	1,34	16 000	9 000	0,87	E2.6309-ZZ	-	
	100	25	55,3	31,5	1,34	15 000	7 500	0,87	* 6309-ZZ	* 6309-Z	
	100	25	55,3	31,5	1,34	-	4 500	0,87	* 6309-2RS1	* 6309-RS1	
	100	36	52,7	31,5	1,34	-	4 500	1,2	62309-2RS1	-	
	50	65	7	6,76	6,8	0,285	20 000	10 000	0,052	61810-2RZ	-
		65	7	6,76	6,8	0,285	-	6 000	0,052	61810-2RS1	-
72		12	14,6	11,8	0,5	19 000	9 500	0,14	61910-2RZ	-	
72		12	14,6	11,8	0,5	-	5 600	0,14	61910-2RS1	-	
80		16	22,9	15,6	0,71	18 000	9 000	0,27	* 6010-ZZ	* 6010-Z	
80		16	22,9	15,6	0,71	18 000	9 000	0,27	* 6010-2RZ	* 6010-RZ	
80		16	22,9	15,6	0,71	-	5 000	0,27	* 6010-2RS1	* 6010-RS1	
80		23	21,6	15,6	0,71	-	5 000	0,38	63010-2RS1	-	
90		20	37,1	23,2	0,98	15 000	8 000	0,47	* 6210-ZZ	* 6210-Z	
90		20	37,1	23,2	0,98	15 000	8 000	0,47	* 6210-2RZ	* 6210-RZ	
90		20	37,1	23,2	0,98	-	4 800	0,47	* 6210-2RS1	* 6210-RS1	
90		23	35,1	23,2	0,98	-	4 800	0,54	62210-2RS1	-	
110		27	62,4	38	1,6	15 000	8 000	1,1	E2.6310-ZZ	-	
110		27	65	38	1,6	13 000	6 700	1,1	* 6310-ZZ	* 6310-Z	
110		27	65	38	1,6	-	4 300	1,1	* 6310-2RS1	* 6310-RS1	
110	40	61,8	38	1,6	-	4 300	1,6	62310-2RS1	-		
55	72	9	9,04	8,8	0,375	19 000	9 500	0,083	61811-2RZ	-	
	72	9	9,04	8,8	0,375	-	5 300	0,083	61811-2RS1	-	
	80	13	16,5	14	0,6	17 000	8 500	0,19	61911-2RZ	-	
	80	13	16,5	14	0,6	-	5 000	0,19	61911-2RS1	-	
	90	18	29,6	21,2	0,9	16 000	8 000	0,4	* 6011-ZZ	* 6011-Z	
	90	18	29,6	21,2	0,9	-	4 500	0,4	* 6011-2RS1	* 6011-RS1	

¹⁾ For bearings with only one shield or one non-contact seal (Z, RZ), the limiting speeds for open bearings are valid.

* SKF Explorer bearing

E2 → SKF Energy Efficient bearing

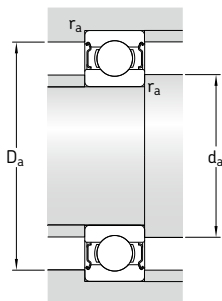

Dimensions				Abutment and fillet dimensions				Calculation factors	
d	d_1 ~	D_2 ~	$r_{1,2}$ min.	d_a min.	d_a max.	D_a max.	r_a max.	k_r	f_0
mm				mm				-	
45 cont.	57,6	75,2	1,1	52	57,5	78	1	0,025	14
	57,6	75,2	1,1	52	57,5	78	1	0,025	14
	57,6	75,2	1,1	52	57,5	78	1	0,025	14
	57,6	75,2	1,1	52	57,5	78	1	0,025	14
	62,1	86,7	1,5	54	62,1	91	1,5	0,03	13
	62,1	86,7	1,5	54	62,1	91	1,5	0,03	13
	62,1	86,7	1,5	54	62,1	91	1,5	0,03	13
	62,1	86,7	1,5	54	62,1	91	1,5	0,03	13
50	55,1	61,8	0,3	52	55	63	0,3	0,015	17
	55,1	61,8	0,3	52	55	63	0,3	0,015	17
	56,9	67,3	0,6	53,2	56,8	68,8	0,6	0,02	16
	56,9	67,3	0,6	53,2	56,8	68,8	0,6	0,02	16
	59,7	72,8	1	54,6	59,7	75,4	1	0,025	15
	59,7	72,8	1	54,6	59,7	75,4	1	0,025	15
	59,7	72,8	1	54,6	59,7	75,4	1	0,025	15
	59,7	72,8	1	54,6	59,7	75,4	1	0,025	15
	62,5	81,7	1,1	57	62,4	83	1	0,025	14
	62,5	81,7	1,1	57	62,4	83	1	0,025	14
	62,5	81,7	1,1	57	62,4	83	1	0,025	14
	62,5	81,7	1,1	57	62,4	83	1	0,025	14
68,7	95,2	2	61	68,7	99	2	0,03	13	
68,7	95,2	2	61	68,7	99	2	0,03	13	
68,7	95,2	2	61	68,7	99	2	0,03	13	
68,7	95,2	2	61	68,7	99	2	0,03	13	
55	60,6	68,6	0,3	57	60,5	70	0,3	0,015	17
	60,6	68,6	0,3	57	60,5	70	0,3	0,015	17
	63,2	74,2	1	59,6	63,1	75,4	1	0,02	16
	63,2	74,2	1	59,6	63,1	75,4	1	0,02	16
	66,3	81,5	1,1	61	66,2	84	1	0,025	15
	66,3	81,5	1,1	61	66,2	84	1	0,025	15

1.2 Capped single row deep groove ball bearings d 55 – 65 mm

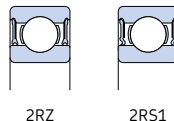
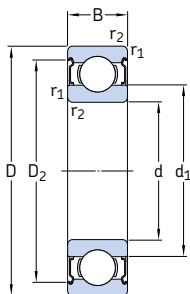

2Z

Principal dimensions			Basic load ratings dynamic static		Fatigue load limit	Speed ratings Reference speed Limiting speed ¹⁾		Mass	Designations Bearing capped on both sides one side		
d	D	B	C	C ₀	P _u	r/min		kg	-		
mm			kN		kN						
55 cont.	100	21	46,2	29	1,25	14 000	7 000	0,64	* 6211-2Z	* 6211-Z	
	100	21	46,2	29	1,25	-	4 300	0,64	* 6211-2RS1	* 6211-RS1	
	100	25	43,6	29	1,25	-	4 300	0,75	62211-2RS1	-	
	120	29	71,5	45	1,9	13 000	7 000	1,4	E2.6311-2Z	-	
	120	29	74,1	45	1,9	12 000	6 300	1,4	* 6311-2Z	* 6311-Z	
	120	29	74,1	45	1,9	-	3 800	1,4	* 6311-2RS1	* 6311-RS1	
	120	43	71,5	45	1,9	-	3 800	2,05	62311-2RS1	-	
60	78	10	11,9	11,4	0,49	17 000	8 500	0,11	61812-2RZ	-	
	78	10	11,9	11,4	0,49	-	4 800	0,11	61812-2RS1	-	
	85	13	16,5	14,3	0,6	16 000	8 000	0,2	61912-2RZ	-	
	85	13	16,5	14,3	0,6	-	4 500	0,2	61912-2RS1	-	
	95	18	30,7	23,2	0,98	15 000	7 500	0,43	* 6012-2Z	* 6012-Z	
	95	18	30,7	23,2	0,98	15 000	7 500	0,43	* 6012-2RZ	* 6012-RZ	
	95	18	30,7	23,2	0,98	-	4 300	0,43	* 6012-2RS1	* 6012-RS1	
	110	22	55,3	36	1,53	13 000	6 300	0,81	* 6212-2Z	* 6212-Z	
	110	22	55,3	36	1,53	-	4 000	0,81	* 6212-2RS1	* 6212-RS1	
	110	28	52,7	36	1,53	-	4 000	1	62212-2RS1	-	
		130	31	81,9	52	2,2	12 000	6 700	1,8	E2.6312-2Z	-
		130	31	85,2	52	2,2	11 000	5 600	1,8	* 6312-2Z	* 6312-Z
	130	31	85,2	52	2,2	-	3 400	1,8	* 6312-2RS1	* 6312-RS1	
	130	46	81,9	52	2,2	-	3 400	2,55	62312-2RS1	-	
65	85	10	12,4	12,7	0,54	16 000	8 000	0,13	61813-2RZ	-	
	85	10	12,4	12,7	0,54	-	4 500	0,13	61813-2RS1	-	
	90	13	17,4	16	0,68	15 000	7 500	0,22	61913-2RZ	-	
	90	13	17,4	16	0,68	-	4 300	0,22	61913-2RS1	-	
	100	18	31,9	25	1,06	14 000	7 000	0,46	* 6013-2Z	* 6013-Z	
	100	18	31,9	25	1,06	-	4 000	0,46	* 6013-2RS1	* 6013-RS1	
	120	23	58,5	40,5	1,73	12 000	6 000	1,05	* 6213-2Z	* 6213-Z	
	120	23	58,5	40,5	1,73	-	3 600	1,05	* 6213-2RS1	* 6213-RS1	
	120	31	55,9	40,5	1,73	-	3 600	1,4	62213-2RS1	-	

¹⁾ For bearings with only one shield or one non-contact seal (Z, RZ), the limiting speeds for open bearings are valid.

* SKF Explorer bearing

E2 → SKF Energy Efficient bearing

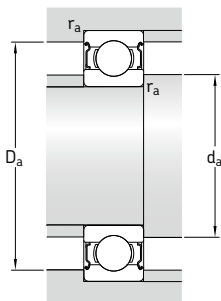

Dimensions				Abutment and fillet dimensions				Calculation factors	
d	d ₁ ~	D ₂ ~	r _{1,2} min.	d _a min.	d _a max.	D _a max.	r _a max.	k _r	f ₀
mm				mm				-	
55 cont.	69	89,4	1,5	64	69	91	1,5	0,025	14
	69	89,4	1,5	64	69	91	1,5	0,025	14
	69	89,4	1,5	64	69	91	1,5	0,025	14
	75,3	104	2	66	75,2	109	2	0,03	13
	75,3	104	2	66	75,2	109	2	0,03	13
	75,3	104	2	66	75,2	109	2	0,03	13
60	65,6	74,5	0,3	62	65,5	76	0,3	0,015	17
	65,6	74,5	0,3	62	65,5	76	0,3	0,015	17
	68,2	79,2	1	64,6	68,1	80,4	1	0,02	16
	68,2	79,2	1	64,6	68,1	80,4	1	0,02	16
	71,3	86,5	1,1	66	71,2	89	1	0,025	16
	71,3	86,5	1,1	66	71,2	89	1	0,025	16
	71,3	86,5	1,1	66	71,2	89	1	0,025	16
	75,5	98	1,5	69	75,4	101	1,5	0,025	14
	75,5	98	1,5	69	75,4	101	1,5	0,025	14
	75,5	98	1,5	69	75,4	101	1,5	0,025	14
	81,8	113	2,1	72	81,8	118	2	0,03	13
	81,8	113	2,1	72	81,8	118	2	0,03	13
65	71,6	80,5	0,6	68,2	71,5	81,8	0,6	0,015	17
	71,6	80,5	0,6	68,2	71,5	81,8	0,6	0,015	17
	73,2	84,2	1	69,6	73,1	85,4	1	0,02	17
	73,2	84,2	1	69,6	73	85,4	1	0,02	17
	76,3	91,5	1,1	71	76,2	94	1	0,025	16
	76,3	91,5	1,1	71	76,2	94	1	0,025	16
	83,3	106	1,5	74	83,2	111	1,5	0,025	15
	83,3	106	1,5	74	83,2	111	1,5	0,025	15
	83,3	106	1,5	74	83,2	111	1,5	0,025	15
	83,3	106	1,5	74	83,2	111	1,5	0,025	15

1.2 Capped single row deep groove ball bearings d 65 – 75 mm

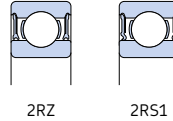
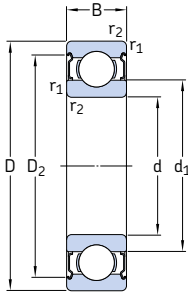

2Z

Principal dimensions			Basic load ratings dynamic static		Fatigue load limit	Speed ratings Reference speed Limiting speed ¹⁾		Mass	Designations Bearing capped on both sides one side	
d	D	B	C	C ₀	P _u			kg	-	
mm			kN		kN	r/min				
65 cont.	140	33	93,6	60	2,5	11 000	5 300	2,15	E2.6313-2Z	-
	140	33	97,5	60	2,5	10 000	5 300	2,15	* 6313-2Z	* 6313-Z
	140	33	97,5	60	2,5	-	3 200	2,15	* 6313-2RS1	* 6313-RS1
	140	48	92,3	60	2,5	-	3 200	3	* 62313-2RS1	-
70	90	10	12,4	13,2	0,56	15 000	7 500	0,14	61814-2RZ	-
	90	10	12,4	13,2	0,56	-	4 300	0,14	61814-2RS1	-
	100	16	23,8	21,2	0,9	14 000	7 000	0,35	61914-2RZ	-
	100	16	23,8	21,2	0,9	-	4 000	0,35	61914-2RS1	-
	110	20	39,7	31	1,32	13 000	6 300	0,64	* 6014-2Z	* 6014-Z
	110	20	39,7	31	1,32	-	3 600	0,63	* 6014-2RS1	* 6014-RS1
	125	24	63,7	45	1,9	11 000	5 600	1,15	* 6214-2Z	* 6214-Z
	125	24	63,7	45	1,9	-	3 400	1,1	* 6214-2RS1	* 6214-RS1
	125	31	60,5	45	1,9	-	3 400	1,4	* 62214-2RS1	-
	150	35	104	68	2,75	11 000	5 000	2,65	E2.6314-2Z	-
	150	35	111	68	2,75	9 500	5 000	2,65	* 6314-2Z	* 6314-Z
	150	35	111	68	2,75	-	3 000	2,6	* 6314-2RS1	* 6314-RS1
150	51	104	68	2,75	-	3 000	3,75	* 62314-2RS1	-	
75	95	10	12,7	14,3	0,61	14 000	7 000	0,15	61815-2RZ	-
	95	10	12,7	14,3	0,61	-	4 000	0,15	61815-2RS1	-
	105	16	24,2	22,4	0,965	13 000	6 300	0,37	61915-2RZ	-
	105	16	24,2	22,4	0,965	-	3 600	0,37	61915-2RS1	-
	115	20	41,6	33,5	1,43	12 000	6 000	0,67	* 6015-2Z	* 6015-Z
	115	20	41,6	33,5	1,43	12 000	6 000	0,7	* 6015-2RZ	* 6015-RZ
	115	20	41,6	33,5	1,43	-	3 400	0,67	* 6015-2RS1	* 6015-RS1
	130	25	68,9	49	2,04	10 000	5 300	1,25	* 6215-2Z	* 6215-Z
	130	25	68,9	49	2,04	-	3 200	1,2	* 6215-2RS1	* 6215-RS1
	160	37	114	76,5	3,05	10 000	4 500	3,15	E2.6315-2Z	-
	160	37	119	76,5	3	9 000	4 500	3,15	* 6315-2Z	* 6315-Z
	160	37	119	76,5	3	-	2 800	3,15	* 6315-2RS1	* 6315-RS1

¹⁾ For bearings with only one shield or one non-contact seal (Z, RZ), the limiting speeds for open bearings are valid.

* SKF Explorer bearing

E2 → SKF Energy Efficient bearing

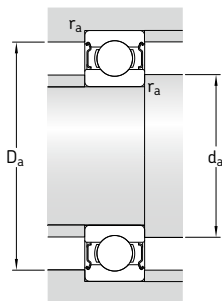

Dimensions				Abutment and fillet dimensions				Calculation factors	
d	d ₁ ~	D ₂ ~	r _{1,2} min.	d _a min.	d _a max.	D _a max.	r _a max.	k _r	f ₀
mm				mm				-	
65 cont.	88,3	122	2,1	77	88,3	128	2	0,03	13
	88,3	122	2,1	77	88,3	128	2	0,03	13
	88,3	122	2,1	77	88,3	128	2	0,03	13
	88,3	122	2,1	77	88,3	128	2	0,03	13
70	76,6	85,5	0,6	73,2	76,5	86,8	0,6	0,015	17
	76,6	85,5	0,6	73,2	76,5	86,8	0,6	0,015	17
	79,7	93,3	1	74,6	79,6	95,4	1	0,02	16
	79,7	93,3	1	74,6	79,6	95,4	1	0,02	16
	82,8	99,9	1,1	76	82,8	104	1	0,025	16
	82,8	99,9	1,1	76	82,8	104	1	0,025	16
	87	111	1,5	79	87	116	1,5	0,025	15
	87	111	1,5	79	87	116	1,5	0,025	15
	87	111	1,5	79	87	116	1,5	0,025	15
	94,9	130	2,1	82	94,9	138	2	0,03	13
	94,9	130	2,1	82	94,9	138	2	0,03	13
	94,9	130	2,1	82	94,9	138	2	0,03	13
75	81,6	90,5	0,6	78,2	81,5	91,8	0,6	0,015	17
	81,6	90,5	0,6	78,2	81,5	91,8	0,6	0,015	17
	84,7	98,3	1	79,6	84,6	100	1	0,02	17
	84,7	98,3	1	79,6	84,6	100	1	0,02	17
	87,8	105	1,1	81	87,8	109	1	0,025	16
	87,8	105	1,1	81	87,8	109	1	0,025	16
	87,8	105	1,1	81	87,8	109	1	0,025	16
	92	117	1,5	84	92	121	1,5	0,025	15
	92	117	1,5	84	92	121	1,5	0,025	15
	101	139	2,1	87	100	148	2	0,03	13
	101	139	2,1	87	100	148	2	0,03	13
	101	139	2,1	87	100	148	2	0,03	13

1.2 Capped single row deep groove ball bearings d 80 – 90 mm

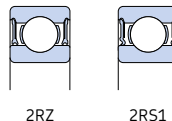
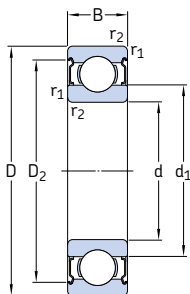

2Z

Principal dimensions			Basic load ratings dynamic static		Fatigue load limit	Speed ratings Reference speed Limiting speed ¹⁾		Mass	Designations Bearing capped on both sides one side	
d	D	B	C	C ₀	P _u					
mm			kN		kN	r/min		kg	-	
80	100	10	13	15	0,64	13 000	6 300	0,15	61816-2RZ	-
	100	10	13	15	0,64	-	3 600	0,15	61816-2RS1	-
	110	16	25,1	20,4	1,02	12 000	6 000	0,4	61916-2RZ	-
	110	16	25,1	20,4	1,02	-	3 400	0,4	61916-2RS1	-
	125	22	49,4	40	1,66	11 000	5 600	0,91	* 6016-2Z	* 6016-Z
	125	22	49,4	40	1,66	-	3 200	0,89	* 6016-2RS1	* 6016-RS1
	140	26	72,8	55	2,2	9 500	4 800	1,55	* 6216-2Z	* 6216-Z
	140	26	72,8	55	2,2	-	3 000	1,5	* 6216-2RS1	* 6216-RS1
	170	39	124	86,5	3,25	9 500	4 300	3,75	E2.6316-2Z	-
	170	39	130	86,5	3,25	8 500	4 300	3,75	* 6316-2Z	* 6316-Z
170	39	130	86,5	3,25	-	2 600	3,7	* 6316-2RS1	* 6316-RS1	
85	110	13	19,5	20,8	0,88	12 000	6 000	0,27	61817-2RZ	-
	110	13	19,5	20,8	0,88	-	3 400	0,27	61817-2RS1	-
	130	22	52	43	1,76	11 000	5 300	0,96	* 6017-2Z	* 6017-Z
	130	22	52	43	1,76	-	3 000	0,94	* 6017-2RS1	* 6017-RS1
	150	28	87,1	64	2,5	9 000	4 500	1,9	* 6217-2Z	* 6217-Z
	150	28	87,1	64	2,5	-	2 800	1,9	* 6217-2RS1	* 6217-RS1
90	180	41	140	96,5	3,55	8 000	4 000	4,4	* 6317-2Z	* 6317-Z
	180	41	140	96,5	3,55	-	2 400	4,35	* 6317-2RS1	* 6317-RS1
	115	13	19,5	22	0,915	11 000	5 600	0,28	61818-2RZ	-
	115	13	19,5	22	0,915	-	3 200	0,28	61818-2RS1	-
	140	24	60,5	50	1,96	10 000	5 000	1,2	* 6018-2Z	* 6018-Z
	140	24	60,5	50	1,96	-	2 800	1,2	* 6018-2RS1	* 6018-RS1
160	30	101	73,5	2,8	8 500	4 300	2,3	* 6218-2Z	* 6218-Z	
160	30	101	73,5	2,8	-	2 600	2,3	* 6218-2RS1	* 6218-RS1	
190	43	151	108	3,8	7 500	3 800	5,1	* 6318-2Z	* 6318-Z	
190	43	151	108	3,8	-	2 400	5,1	* 6318-2RS1	* 6318-RS1	

¹⁾ For bearings with only one shield or one non-contact seal (Z, RZ), the limiting speeds for open bearings are valid.

* SKF Explorer bearing

E2 → SKF Energy Efficient bearing

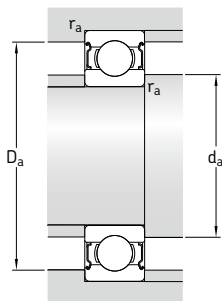

Dimensions				Abutment and fillet dimensions				Calculation factors	
d	d_1 ~	D_2 ~	$r_{1,2}$ min.	d_a min.	d_a max.	D_a max.	r_a max.	k_r	f_0
mm				mm				-	
80	86,6	95,5	0,6	83,2	86,5	96,8	0,6	0,015	17
	86,6	95,5	0,6	83,2	86,5	96,8	0,6	0,015	17
	89,8	103	1	84,6	89,7	105	1	0,02	14
	89,8	103	1	84,6	89,7	105	1	0,02	14
	94,4	115	1,1	86	94,3	119	1	0,025	16
	94,4	115	1,1	86	94,3	119	1	0,025	16
	101	127	2	91	100	129	2	0,025	15
	101	127	2	91	100	129	2	0,025	15
	108	147	2,1	92	107	158	2	0,03	13
	108	147	2,1	92	107	158	2	0,03	13
108	147	2,1	92	107	158	2	0,03	13	
85	93,2	105	1	89,6	93,1	105	1	0,015	17
	93,2	105	1	89,6	93,1	105	1	0,015	17
	99,4	120	1,1	92	99,3	123	1	0,025	16
	99,4	120	1,1	92	99,3	123	1	0,025	16
	106	135	2	96	105	139	2	0,025	15
	106	135	2	96	105	139	2	0,025	15
114	156	3	99	114	166	2,5	0,03	13	
114	156	3	99	114	166	2,5	0,03	13	
90	98,2	110	1	94,6	98,1	110	1	0,015	17
	98,2	110	1	94,6	98,1	110	1	0,015	17
	105	129	1,5	97	105	133	1,5	0,025	16
	105	129	1,5	97	105	133	1,5	0,025	16
	112	143	2	101	112	149	2	0,025	15
	112	143	2	101	112	149	2	0,025	15
	121	164	3	104	120	176	2,5	0,03	13
	121	164	3	104	120	176	2,5	0,03	13

1.2 Capped single row deep groove ball bearings d 95 – 110 mm

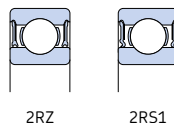
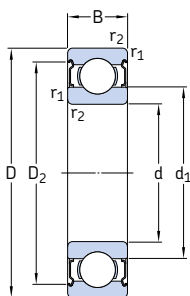

ZZ

Principal dimensions			Basic load ratings dynamic static		Fatigue load limit	Speed ratings Reference speed Limiting speed ¹⁾		Mass	Designations Bearing capped on both sides one side		
d	D	B	C	C ₀	P _u			kg	-		
mm			kN		kN	r/min					
95	120	13	19,9	22,8	0,93	11 000	5 300	0,3	61819-2RZ	-	
	120	13	19,9	22,8	0,93	-	3 000	0,3	61819-2RS1	-	
	130	18	33,8	33,5	1,34	-	3 000	0,65	61919-2RS1	-	
	145	24	63,7	54	2,08	9 500	4 800	1,25	* 6019-Z	* 6019-Z	
	145	24	63,7	54	2,08	-	2 800	1,25	* 6019-2RS1	* 6019-RS1	
	170	32	114	81,5	3	8 000	4 000	2,75	* 6219-Z	* 6219-Z	
	170	32	114	81,5	3	-	2 400	2,75	* 6219-2RS1	* 6219-RS1	
	200	45	159	118	4,15	7 000	3 600	5,85	* 6319-Z	* 6319-Z	
	200	45	159	118	4,15	-	2 200	5,85	* 6319-2RS1	* 6319-RS1	
	100	125	13	17,8	18,3	0,95	10 000	5 300	0,31	61820-2RZ	-
125		13	17,8	18,3	0,95	-	3 000	0,31	61820-2RS1	-	
150		24	63,7	54	2,04	9 500	4 500	1,35	* 6020-Z	* 6020-Z	
150		24	63,7	54	2,04	-	2 600	1,3	* 6020-2RS1	* 6020-RS1	
180		34	127	93	3,35	7 500	3 800	3,3	* 6220-Z	* 6220-Z	
180		34	127	93	3,35	-	2 400	3,3	* 6220-2RS1	* 6220-RS1	
215		47	174	140	4,75	6 700	3 400	7,3	6320-Z	6320-Z	
215		47	174	140	4,75	-	2 000	7,1	6320-2RS1	6320-RS1	
105		130	13	20,8	19,6	1	10 000	5 000	0,32	61821-2RZ	-
		130	13	20,8	19,6	1	-	2 800	0,32	61821-2RS1	-
	160	26	76,1	65,5	2,4	8 500	4 300	1,65	* 6021-Z	* 6021-Z	
	160	26	76,1	65,5	2,4	-	2 400	1,65	* 6021-2RS1	* 6021-RS1	
	190	36	140	104	3,65	7 000	3 600	3,9	* 6221-Z	* 6221-Z	
	190	36	140	104	3,65	-	2 200	3,95	* 6221-2RS1	* 6221-RS1	
	225	49	182	153	5,1	6 300	3 200	8,25	6321-Z	6321-Z	
	110	140	16	28,1	26	1,25	9 500	4 500	0,6	61822-2RZ	-
		140	16	28,1	26	1,25	-	2 600	0,6	61822-2RS1	-
		170	28	85,2	73,5	2,4	8 000	4 000	2,05	* 6022-Z	* 6022-Z
170		28	85,2	73,5	2,4	-	2 400	2,05	* 6022-2RS1	* 6022-RS1	
200		38	151	118	4	6 700	3 400	4,5	* 6222-Z	* 6222-Z	
200		38	151	118	4	-	2 000	4,5	* 6222-2RS1	* 6222-RS1	
240		50	203	180	5,7	6 000	3 000	9,7	6322-Z	6322-Z	
240		50	203	180	5,7	-	1 800	9,7	6322-2RS1	6322-RS1	

¹⁾ For bearings with only one shield or one non-contact seal (Z, RZ), the limiting speeds for open bearings are valid.

* SKF Explorer bearing

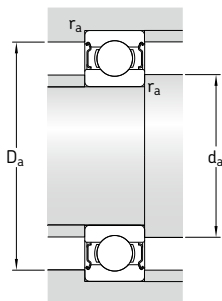

Dimensions				Abutment and fillet dimensions				Calculation factors	
d	d_1 ~	D_2 ~	$r_{1,2}$ min.	d_a min.	d_a max.	D_a max.	r_a max.	k_r	f_0
mm				mm				-	
95	103	115	1	99,6	102	115	1	0,015	17
	103	115	1	99,6	102	115	1	0,015	17
	106	122	1,1	101	105	124	1	0,02	17
	111	134	1,5	102	111	138	1,5	0,025	16
	111	134	1,5	102	111	138	1,5	0,025	16
	118	152	2,1	107	118	158	2	0,025	14
	118	152	2,1	107	118	158	2	0,025	14
	127	172	3	109	127	186	2,5	0,03	13
	127	172	3	109	127	186	2,5	0,03	13
	100	108	120	1	105	107	120	1	0,015
108		120	1	105	107	120	1	0,015	13
115		139	1,5	107	115	143	1,5	0,025	16
115		139	1,5	107	115	143	1,5	0,025	16
124		160	2,1	112	124	168	2	0,025	14
124		160	2,1	112	124	168	2	0,025	14
135		184	3	114	135	201	2,5	0,03	13
135		184	3	114	135	201	2,5	0,03	13
105	112	125	1	110	112	125	1	0,015	13
	112	125	1	110	112	125	1	0,015	13
	122	147	2	116	122	149	2	0,025	16
	122	147	2	116	122	149	2	0,025	16
	131	167	2,1	117	131	178	2	0,025	14
	131	167	2,1	117	131	178	2	0,025	14
110	141	194	3	119	140	211	2,5	0,03	13
	118	135	1	115	118	135	1	0,015	14
	118	135	1	115	118	135	1	0,015	14
	129	156	2	119	128	161	2	0,025	16
	129	156	2	119	128	161	2	0,025	16
	138	177	2,1	122	137	188	2	0,025	14
	138	177	2,1	122	137	188	2	0,025	14
	149	209	3	124	149	226	2,5	0,03	13
	149	209	3	124	149	226	2,5	0,03	13

1.2 Capped single row deep groove ball bearings d 120 – 160 mm

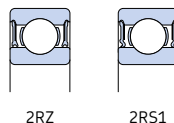
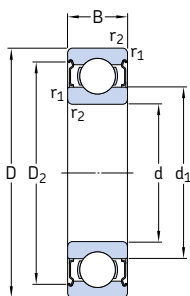

2Z

Principal dimensions			Basic load ratings dynamic static		Fatigue load limit	Speed ratings Reference speed Limiting speed ¹⁾		Mass	Designations Bearing capped on both sides	one side
d	D	B	C	C ₀	P _u			kg	-	-
mm			kN		kN	r/min			-	
120	150	16	29,1	28	1,29	8 500	4 300	0,65	61824-2RZ	-
	150	16	29,1	28	1,29	-	2 400	0,65	61824-2RS1	-
	180	28	88,4	80	2,75	7 500	3 800	2,2	* 6024-2Z	* 6024-Z
	180	28	88,4	80	2,75	-	2 200	2,15	* 6024-2RS1	* 6024-RS1
	215	40	146	118	3,9	6 300	3 200	5,35	6224-2Z	6224-Z
	215	40	146	118	3,9	-	1 900	5,3	6224-2RS1	6224-RS1
	260	55	208	186	5,7	5 600	2 800	12,7	6324-2Z	6324-Z
	260	55	208	186	5,7	-	1 700	12,6	6324-2RS1	6324-RS1
130	165	18	37,7	43	1,6	8 000	3 800	0,93	61826-2RZ	-
	165	18	37,7	43	1,6	-	2 200	0,93	61826-2RS1	-
	200	33	112	100	3,35	7 000	3 400	3,35	* 6026-2Z	* 6026-Z
	200	33	112	100	3,35	-	2 000	3,35	* 6026-2RS1	* 6026-RS1
	230	40	156	132	4,15	5 600	3 000	6	6226-2Z	6226-Z
	230	40	156	132	4,15	-	1 800	5,9	6226-2RS1	6226-RS1
140	175	18	39	46,5	1,66	7 500	3 600	0,99	61828-2RZ	-
	175	18	39	46,5	1,66	-	2 000	0,99	61828-2RS1	-
	210	33	111	108	3,45	6 700	3 200	3,6	6028-2Z	6028-Z
	210	33	111	108	3,45	-	1 800	3,55	6028-2RS1	6028-RS1
150	225	35	125	125	3,9	6 000	3 000	4,35	6030-2Z	6030-Z
	225	35	125	125	3,9	-	1 700	4,35	6030-2RS1	6030-RS1
160	240	38	143	143	4,3	5 600	2 800	5,35	6032-2Z	6032-Z
	240	38	143	143	4,3	-	1 600	5,3	6032-2RS1	6032-RS1

¹⁾ For bearings with only one shield or one non-contact seal (Z, RZ), the limiting speeds for open bearings are valid.

* SKF Explorer bearing

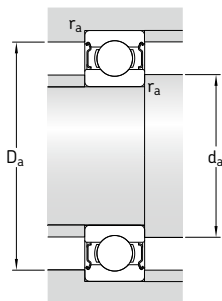

Dimensions				Abutment and fillet dimensions				Calculation factors	
d	d_1 ~	D_2 ~	$r_{1,2}$ min.	d_a min.	d_a max.	D_a max.	r_a max.	k_r	f_0
mm				mm				-	
120	128	145	1	125	128	145	1	0,015	14
	128	145	1	125	128	145	1	0,015	14
	139	166	2	129	139	171	2	0,025	16
	139	166	2	129	139	171	2	0,025	16
	150	190	2,1	132	150	203	2	0,025	14
	150	190	2,1	132	150	203	2	0,025	14
	165	220	3	134	164	246	2,5	0,03	14
	165	220	3	134	164	246	2,5	0,03	14
130	140	158	1,1	136	139	159	1	0,015	16
	140	158	1,1	136	139	159	1	0,015	16
	152	182	2	139	152	191	2	0,025	16
	152	182	2	139	152	191	2	0,025	16
	160	203	3	144	160	216	2,5	0,025	15
	160	203	3	144	160	216	2,5	0,025	15
140	150	167	1,1	146	150	169	1	0,015	16
	150	167	1,1	146	150	169	1	0,015	16
	162	192	2	149	162	201	2	0,025	16
	162	192	2	149	162	201	2	0,025	16
150	174	206	2,1	160	173	215	2	0,025	16
	174	206	2,1	160	173	215	2	0,025	16
160	185	219	2,1	169	185	231	2	0,025	16
	185	219	2,1	169	185	231	2	0,025	16

1.3 ICOS oil sealed bearing units d 12 – 30 mm

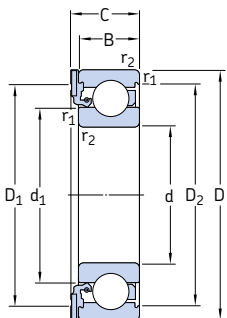

Principal dimensions				Basic load ratings		Fatigue load limit	Limiting speed	Mass	Designation
d	D	B	C	dynamic	static				
				C	C ₀	P _u			
mm				kN		kN	r/min	kg	–
12	32	10	12,6	7,28	3,1	0,132	14 000	0,041	* ICOS-D1B01 TN9
15	35	11	13,2	8,06	3,75	0,16	12 000	0,048	* ICOS-D1B02 TN9
17	40	12	14,2	9,95	4,75	0,2	11 000	0,071	* ICOS-D1B03 TN9
20	47	14	16,2	13,5	6,55	0,28	9 300	0,11	* ICOS-D1B04 TN9
25	52	15	17,2	14,8	7,8	0,335	7 700	0,14	* ICOS-D1B05 TN9
30	62	16	19,4	20,3	11,2	0,475	6 500	0,22	* ICOS-D1B06 TN9

* SKF Explorer bearing

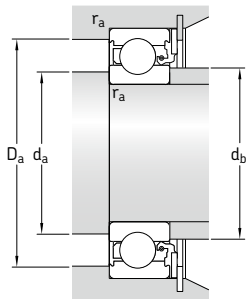

Dimensions					Abutment and fillet dimensions					Calculation factors	
d	d_1 ~	D_1 ~	D_2 ~	$r_{1,2}$ min.	d_a, d_b min.	d_a max.	d_b max.	D_a max.	r_a max.	k_f	f_0
mm					mm					-	
12	18,4	⁻¹⁾	27,34	0,6	16,2	18,4	18	27,8	0,6	0,025	12
15	21,7	30,8	30,35	0,6	19,2	21,7	21,5	30,8	0,6	0,025	13
17	24,5	35,6	34,98	0,6	21,2	24,5	24	35,8	0,6	0,025	13
20	28,8	42	40,59	1	25,6	28,8	28,5	41,4	1	0,025	13
25	34,3	47	46,21	1	30,6	34,3	34	46,4	1	0,025	14
30	40,3	55,6	54,06	1	35,6	40,3	40	56,4	1	0,025	14

¹⁾ Full rubber cross section

1.4 Single row deep groove ball bearings with a snap ring groove d 10 – 45 mm

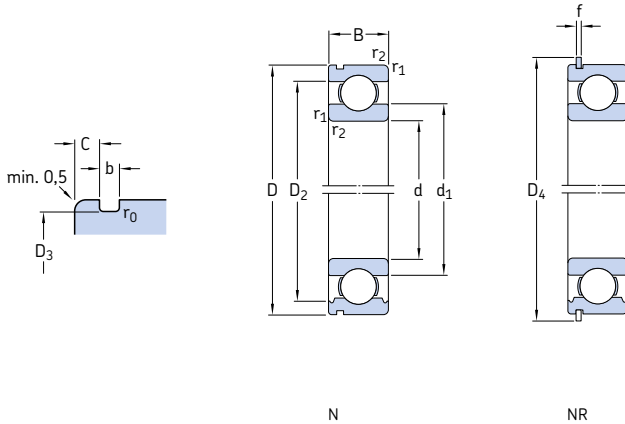

Principal dimensions			Basic load ratings		Fatigue load limit	Speed ratings		Mass	Designations		Snap ring
d	D	B	C	C ₀		Reference speed	Limiting speed		Bearing with snap ring groove	snap ring groove and snap ring	
mm			kN		kN	r/min		kg	-		
10	30	9	5,4	2,36	0,1	56 000	36 000	0,032	* 6200 N	* 6200 NR	SP 30
12	32	10	7,28	3,1	0,132	50 000	32 000	0,037	* 6201 N	* 6201 NR	SP 32
15	35	11	8,06	3,75	0,16	43 000	28 000	0,045	* 6202 N	* 6202 NR	SP 35
17	40	12	9,95	4,75	0,2	38 000	24 000	0,065	* 6203 N	* 6203 NR	SP 40
	47	14	14,3	6,55	0,275	34 000	22 000	0,12	* 6303 N	* 6303 NR	SP 47
20	42	12	9,95	5	0,212	38 000	24 000	0,069	* 6004 N	* 6004 NR	SP 42
	47	14	13,5	6,55	0,28	32 000	20 000	0,11	* 6204 N	* 6204 NR	SP 47
	52	15	16,8	7,8	0,335	30 000	19 000	0,14	* 6304 N	* 6304 NR	SP 52
25	47	12	11,9	6,55	0,275	32 000	20 000	0,08	* 6005 N	* 6005 NR	SP 47
	52	15	14,8	7,8	0,335	28 000	18 000	0,13	* 6205 N	* 6205 NR	SP 52
	62	17	23,4	11,6	0,49	24 000	16 000	0,22	* 6305 N	* 6305 NR	SP 62
30	55	13	13,8	8,3	0,355	28 000	17 000	0,12	* 6006 N	* 6006 NR	SP 55
	62	16	20,3	11,2	0,475	24 000	15 000	0,2	* 6206 N	* 6206 NR	SP 62
	72	19	29,6	16	0,67	20 000	13 000	0,35	* 6306 N	* 6306 NR	SP 72
35	62	14	16,8	10,2	0,44	24 000	15 000	0,15	* 6007 N	* 6007 NR	SP 62
	72	17	27	15,3	0,655	20 000	13 000	0,3	* 6207 N	* 6207 NR	SP 72
	80	21	35,1	19	0,82	19 000	12 000	0,45	* 6307 N	* 6307 NR	SP 80
	100	25	55,3	31	1,29	16 000	10 000	0,96	* 6407 N	* 6407 NR	SP 100
40	68	15	17,8	11	0,49	22 000	14 000	0,19	* 6008 N	* 6008 NR	SP 68
	80	18	32,5	19	0,8	18 000	11 000	0,36	* 6208 N	* 6208 NR	SP 80
	90	23	42,3	24	1,02	17 000	11 000	0,62	* 6308 N	* 6308 NR	SP 90
	110	27	63,7	36,5	1,53	14 000	9 000	1,25	* 6408 N	* 6408 NR	SP 110
45	75	16	22,1	14,6	0,64	20 000	12 000	0,24	* 6009 N	* 6009 NR	SP 75
	85	19	35,1	21,6	0,915	17 000	11 000	0,41	* 6209 N	* 6209 NR	SP 85
	100	25	55,3	31,5	1,34	15 000	9 500	0,83	* 6309 N	* 6309 NR	SP 100
	120	29	76,1	45	1,9	13 000	8 500	1,55	* 6409 N	* 6409 NR	SP 120

* SKF Explorer bearing

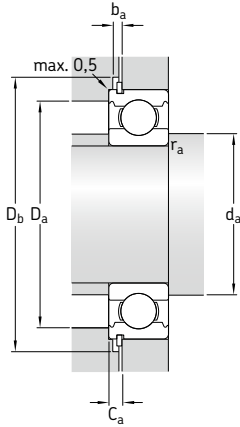

Dimensions										Abutment and fillet dimensions						Calculation factors	
d	d ₁	D ₂	D ₃	D ₄	b	f	C	r _{1,2}	r ₀	d _a	D _a	D _b	b _a	C _a	r _a	k _r	f ₀
mm										mm						-	
10	17	24,8	28,17	34,7	1,35	1,12	2,06	0,6	0,4	14,2	25,8	36	1,5	3,18	0,6	0,025	13
12	18,4	27,4	30,15	36,7	1,35	1,12	2,06	0,6	0,4	16,2	27,8	38	1,5	3,18	0,6	0,025	12
15	21,7	30,4	33,17	39,7	1,35	1,12	2,06	0,6	0,4	19,2	30,8	41	1,5	3,18	0,6	0,025	13
17	24,5	35	38,1	44,6	1,35	1,12	2,06	0,6	0,4	21,2	35,8	46	1,5	3,18	0,6	0,025	13
	26,5	39,6	44,6	52,7	1,35	1,12	2,46	1	0,4	22,6	41,4	54	1,5	3,58	1	0,03	12
20	27,2	37,2	39,75	46,3	1,35	1,12	2,06	0,6	0,4	23,2	38,8	48	1,5	3,18	0,6	0,025	14
	28,8	40,6	44,6	52,7	1,35	1,12	2,46	1	0,4	25,6	41,4	54	1,5	3,58	1	0,025	13
	30,3	44,8	49,73	57,9	1,35	1,12	2,46	1,1	0,4	27	45	59	1,5	3,58	1	0,03	12
25	32	42,2	44,6	52,7	1,35	1,12	2,06	0,6	0,4	28,2	43,8	54	1,5	3,18	0,6	0,025	14
	34,3	46,3	49,73	57,9	1,35	1,12	2,46	1	0,4	30,6	46,4	59	1,5	3,58	1	0,025	14
	36,6	52,7	59,61	67,7	1,9	1,7	3,28	1,1	0,6	32	55	69	2,2	4,98	1	0,03	12
30	38,2	49	52,6	60,7	1,35	1,12	2,06	1	0,4	34,6	50,4	62	1,5	3,18	1	0,025	15
	40,3	54,1	59,61	67,7	1,9	1,7	3,28	1	0,6	35,6	56,4	69	2,2	4,98	1	0,025	14
	44,6	61,9	68,81	78,6	1,9	1,7	3,28	1,1	0,6	37	65	80	2,2	4,98	1	0,03	13
35	43,7	55,7	59,61	67,7	1,9	1,7	2,06	1	0,6	39,6	57,4	69	2,2	3,76	1	0,025	15
	46,9	62,7	68,81	78,6	1,9	1,7	3,28	1,1	0,6	42	65	80	2,2	4,98	1	0,025	14
	49,5	69,2	76,81	86,6	1,9	1,7	3,28	1,5	0,6	44	71	88	2,2	4,98	1,5	0,03	13
	57,4	79,6	96,8	106,5	2,7	2,46	3,28	1,5	0,6	46	89	108	3	5,74	1,5	0,035	12
40	49,2	61,1	64,82	74,6	1,9	1,7	2,49	1	0,6	44,6	63,4	76	2,2	4,19	1	0,025	15
	52,6	69,8	76,81	86,6	1,9	1,7	3,28	1,1	0,6	47	73	88	2,2	4,98	1	0,025	14
	56,1	77,7	86,79	96,5	2,7	2,46	3,28	1,5	0,6	49	81	98	3	5,74	1,5	0,03	13
	62,8	87	106,81	116,6	2,7	2,46	3,28	2	0,6	53	97	118	3	5,74	2	0,035	12
45	54,7	67,8	71,83	81,6	1,9	1,7	2,49	1	0,6	50,8	69,2	83	2,2	4,19	1	0,025	15
	57,6	75,2	81,81	91,6	1,9	1,7	3,28	1,1	0,6	52	78	93	2,2	4,98	1	0,025	14
	62,1	86,7	96,8	106,5	2,7	2,46	3,28	1,5	0,6	54	91	108	3	5,74	1,5	0,03	13
	68,9	95,9	115,21	129,7	3,1	2,82	4,06	2	0,6	58	107	131	3,5	6,88	2	0,035	12

1.4 Single row deep groove ball bearings with a snap ring groove d 50 – 90 mm

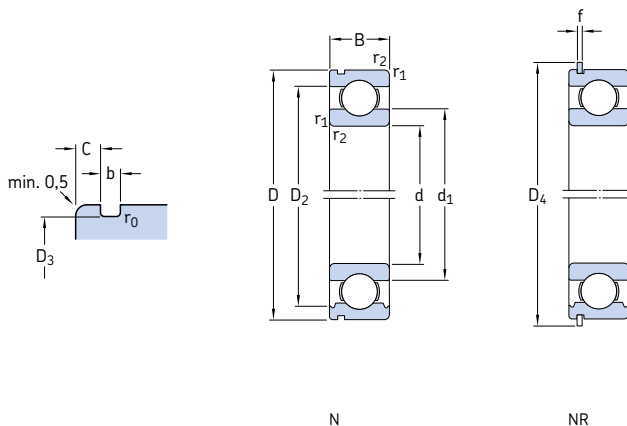

Principal dimensions			Basic load ratings dynamic static		Fatigue load limit	Speed ratings Reference speed Limiting speed		Mass	Designations Bearing with snap ring groove snap ring groove and snap ring		Snap ring
d	D	B	C	C ₀	P _u			kg	-		
mm			kN		kN	r/min					
50	80	16	22,9	16	0,71	18 000	11 000	0,26	* 6010 N	* 6010 NR	SP 80
	90	20	37,1	23,2	0,98	15 000	10 000	0,47	* 6210 N	* 6210 NR	SP 90
	110	27	65	38	1,6	13 000	8 500	1,05	* 6310 N	* 6310 NR	SP 110
	130	31	87,1	52	2,2	12 000	7 500	1,9	* 6410 N	* 6410 NR	SP 130
55	90	18	29,6	21,2	0,9	16 000	10 000	0,38	* 6011 N	* 6011 NR	SP 90
	100	21	46,2	29	1,25	14 000	9 000	0,6	* 6211 N	* 6211 NR	SP 100
	120	29	74,1	45	1,9	12 000	8 000	1,35	* 6311 N	* 6311 NR	SP 120
	140	33	99,5	62	2,6	11 000	7 000	2,35	* 6411 N	* 6411 NR	SP 140
60	95	18	30,7	23,2	0,98	15 000	9 500	0,4	* 6012 N	* 6012 NR	SP 95
	110	22	55,3	36	1,53	13 000	8 000	0,77	* 6212 N	* 6212 NR	SP 110
	130	31	85,2	52	2,2	11 000	7 000	1,7	* 6312 N	* 6312 NR	SP 130
	150	35	108	69,5	2,9	10 000	6 300	2,8	* 6412 N	* 6412 NR	SP 150
65	100	18	31,9	25	1,06	14 000	9 000	0,43	* 6013 N	* 6013 NR	SP 100
	120	23	58,5	40,5	1,73	12 000	7 500	1	* 6213 N	* 6213 NR	SP 120
	140	33	97,5	60	2,5	10 000	6 700	2,1	* 6313 N	* 6313 NR	SP 140
	160	37	119	78	3,15	9 500	6 000	3,35	* 6413 N	* 6413 NR	SP 160
70	110	20	39,7	31	1,32	13 000	8 000	0,6	* 6014 N	* 6014 NR	SP 110
	125	24	63,7	45	1,9	11 000	7 000	1,05	* 6214 N	* 6214 NR	SP 125
	150	35	111	68	2,75	9 500	6 300	2,55	* 6314 N	* 6314 NR	SP 150
75	115	20	41,6	33,5	1,43	12 000	7 500	0,64	* 6015 N	* 6015 NR	SP 115
	130	25	68,9	49	2,04	10 000	6 700	1,15	* 6215 N	* 6215 NR	SP 130
	160	37	119	76,5	3	9 000	5 600	3	* 6315 N	* 6315 NR	SP 160
80	125	22	49,4	40	1,66	11 000	7 000	0,85	* 6016 N	* 6016 NR	SP 125
	140	26	72,8	55	2,2	9 500	6 000	1,45	* 6216 N	* 6216 NR	SP 140
85	130	22	52	43	1,76	11 000	6 700	0,9	* 6017 N	* 6017 NR	SP 130
	150	28	87,1	64	2,5	9 000	5 600	1,8	* 6217 N	* 6217 NR	SP 150
90	140	24	60,5	50	1,96	10 000	6 300	1,1	* 6018 N	* 6018 NR	SP 140
	160	30	101	73,5	2,8	8 500	5 300	2,2	* 6218 N	* 6218 NR	SP 160

* SKF Explorer bearing

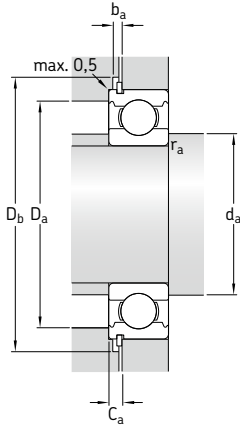

Dimensions										Abutment and fillet dimensions						Calculation factors	
d	d_1	D_2	D_3	D_4	b	f	C	$r_{1,2}$	r_0	d_a	D_a	D_b	b_a	C_a	r_a	k_f	f_0
mm										mm						-	
50	59,7	72,8	76,81	86,6	1,9	1,7	2,49	1	0,6	54,6	75,4	88	2,2	4,19	1	0,025	15
	62,5	81,7	86,79	96,5	2,7	2,46	3,28	1,1	0,6	57	83	98	3	5,74	1	0,025	14
	68,7	95,2	106,81	116,6	2,7	2,46	3,28	2	0,6	61	99	118	3	5,74	2	0,03	13
	75,4	105	125,22	139,7	3,1	2,82	4,06	2,1	0,6	64	116	141	3,5	6,88	2	0,035	12
55	66,3	81,5	86,79	96,5	2,7	2,46	2,87	1,1	0,6	61	84	98	3	5,33	1	0,025	15
	69	89,4	96,8	106,5	2,7	2,46	3,28	1,5	0,6	64	91	108	3	5,74	1,5	0,025	14
	75,3	104	115,21	129,7	3,1	2,82	4,06	2	0,6	66	109	131	3,5	6,88	2	0,03	13
	81,5	114	135,23	149,7	3,1	2,82	4,9	2,1	0,6	69	126	151	3,5	7,72	2	0,035	12
60	71,3	86,5	91,82	101,6	2,7	2,46	2,87	1,1	0,6	61	89	103	3	5,33	1	0,025	16
	75,5	98	106,81	116,6	2,7	2,46	3,28	1,5	0,6	69	101	118	3	5,74	1,5	0,025	14
	81,8	113	125,22	139,7	3,1	2,82	4,06	2,1	0,6	72	118	141	3,5	6,88	2	0,03	13
	88,1	122	145,24	159,7	3,1	2,82	4,9	2,1	0,6	74	136	162	3,5	7,72	2	0,035	12
65	76,3	91,5	96,8	106,5	2,7	2,46	2,87	1,1	0,6	71	94	108	3	5,33	1	0,025	16
	83,3	106	115,21	129,7	3,1	2,82	4,06	1,5	0,6	74	111	131	3,5	6,88	1,5	0,025	15
	88,3	122	135,23	149,7	3,1	2,82	4,9	2,1	0,6	77	128	151	3,5	7,72	2	0,03	13
	94	131	155,22	169,7	3,1	2,82	4,9	2,1	0,6	79	146	172	3,5	7,72	2	0,035	12
70	82,8	99,9	106,81	116,6	2,7	2,46	2,87	1,1	0,6	76	104	118	3	5,33	1	0,025	16
	87	111	120,22	134,7	3,1	2,82	4,06	1,5	0,6	79	116	136	3,5	6,88	1,5	0,025	15
	94,9	130	145,25	159,7	3,1	2,82	4,9	2,1	0,6	82	138	162	3,5	7,72	2	0,03	13
75	87,8	105	111,81	121,6	2,7	2,46	2,87	1,1	0,6	81	109	123	3	5,33	1	0,025	16
	92	117	125,22	139,7	3,1	2,82	4,06	1,5	0,6	84	121	141	3,5	6,88	1,5	0,025	15
	101	139	155,22	169,7	3,1	2,82	4,9	2,1	0,6	87	148	172	3,5	7,72	2	0,03	13
80	94,4	115	120,22	134,7	3,1	2,82	2,87	1,1	0,6	86	119	136	3,5	5,69	1	0,025	16
	101	127	135,23	149,7	3,1	2,82	4,9	2	0,6	91	129	151	3,5	7,72	2	0,025	15
85	99,4	120	125,22	139,7	3,1	2,82	2,87	1,1	0,6	92	123	141	3,5	5,69	1	0,025	16
	106	135	145,24	159,7	3,1	2,82	4,9	2	0,6	96	139	162	3,5	7,72	2	0,025	15
90	105	129	135,23	149,7	3,1	2,82	3,71	1,5	0,6	97	133	151	3,5	6,53	1,5	0,025	16
	112	143	155,22	169,7	3,1	2,82	4,9	2	0,6	101	149	172	3,5	7,72	2	0,025	15

1.4 Single row deep groove ball bearings with a snap ring groove d 95 – 120 mm

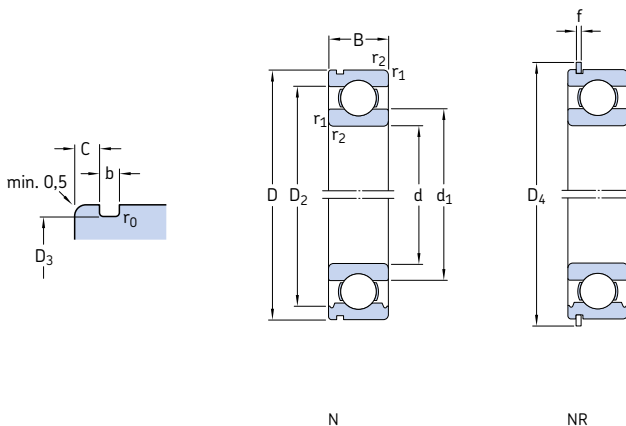

Principal dimensions			Basic load ratings dynamic static		Fatigue load limit	Speed ratings Reference speed Limiting speed		Mass	Designations Bearing with snap ring groove snap ring groove and snap ring		Snap ring
d	D	B	C	C ₀	P _u			kg	-		
mm			kN		kN	r/min					
95	170	32	114	81,5	3	8 000	5 000	2,6	* 6219 N	* 6219 NR	SP 170
100	150	24	63,7	54	2,04	9 500	5 600	1,25	* 6020 N	* 6020 NR	SP 150
	180	34	127	93	3,35	7 500	4 800	3,15	* 6220 N	* 6220 NR	SP 180
105	160	26	76,1	65,5	2,4	8 500	5 300	1,6	* 6021 N	* 6021 NR	SP 160
110	170	28	85,2	73,5	2,6	8 000	5 000	1,95	* 6022 N	* 6022 NR	SP 170
120	180	28	88,4	80	2,75	7 500	4 800	2,05	* 6024 N	* 6024 NR	SP 180

* SKF Explorer bearing

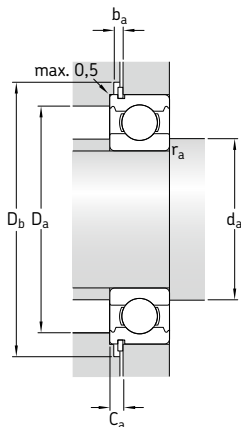

Dimensions											Abutment and fillet dimensions					Calculation factors	
d	d_1	D_2	D_3	D_4	b	f	C	$r_{1,2}$	r_0	d_a	D_a	D_b	b_a	C_a	r_a	k_f	f_0
mm										mm					-		
95	118	152	163,65	182,9	3,5	3,1	5,69	2,1	0,6	107	158	185	4	8,79	2	0,025	14
100	115	139	145,24	159,7	3,1	2,82	3,71	1,5	0,6	107	143	162	3,5	6,53	1,5	0,025	16
	124	160	173,66	192,9	3,5	3,1	5,69	2,1	0,6	112	168	195	4	8,79	2	0,025	14
105	122	147	155,22	169,7	3,1	2,82	3,71	2	0,6	116	149	172	3,5	6,53	2	0,025	16
110	129	156	163,65	182,9	3,5	3,1	3,71	2	0,6	119	161	185	4	6,81	2	0,025	16
120	139	166	173,66	192,9	3,5	3,1	3,71	2	0,6	129	171	195	4	6,81	2	0,025	16

1.5 Single row deep groove ball bearings with a snap ring and shields

d 10 – 60 mm

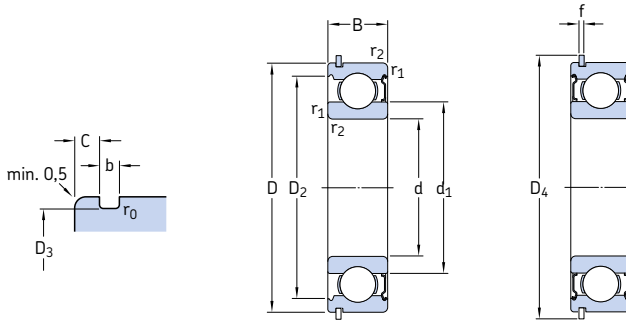

ZNR

ZZNR

Principal dimensions			Basic load ratings		Fatigue load limit	Speed ratings		Mass	Designations		Snap ring
d	D	B	C	C ₀	P _u	Reference speed	Limiting speed ¹⁾	kg	Bearing with a snap ring and a shield on one side		Snap ring
mm			kN		kN	r/min		kg	-		
10	30	9	5,4	2,36	0,1	56 000	36 000	0,032	* 6200-ZNR	* 6200-ZZNR	SP 30
12	32	10	7,28	3,1	0,132	50 000	32 000	0,037	* 6201-ZNR	* 6201-ZZNR	SP 32
15	35	11	8,06	3,75	0,16	43 000	28 000	0,045	* 6202-ZNR	* 6202-ZZNR	SP 35
17	40	12	9,95	4,75	0,2	38 000	24 000	0,065	* 6203-ZNR	* 6203-ZZNR	SP 40
	47	14	14,3	6,55	0,275	34 000	22 000	0,12	* 6303-ZNR	* 6303-ZZNR	SP 47
20	42	12	9,95	5	0,212	38 000	24 000	0,069	* 6004-ZNR	* 6004-ZZNR	SP 42
	47	14	13,5	6,55	0,28	32 000	20 000	0,11	* 6204-ZNR	* 6204-ZZNR	SP 47
	52	15	16,8	7,8	0,335	30 000	19 000	0,15	* 6304-ZNR	* 6304-ZZNR	SP 52
25	47	12	11,9	6,55	0,275	32 000	20 000	0,08	* 6005-ZNR	* 6005-ZZNR	SP 47
	52	15	14,8	7,8	0,335	28 000	18 000	0,13	* 6205-ZNR	* 6205-ZZNR	SP 52
	62	17	23,4	11,6	0,49	24 000	16 000	0,24	* 6305-ZNR	* 6305-ZZNR	SP 62
30	62	16	20,3	11,2	0,475	24 000	15 000	0,21	* 6206-ZNR	* 6206-ZZNR	SP 62
	72	19	29,6	16	0,67	20 000	13 000	0,37	* 6306-ZNR	* 6306-ZZNR	SP 72
35	72	17	27	15,3	0,655	20 000	13 000	0,3	* 6207-ZNR	* 6207-ZZNR	SP 72
	80	21	35,1	19	0,82	19 000	12 000	0,47	* 6307-ZNR	* 6307-ZZNR	SP 80
40	80	18	32,5	19	0,8	18 000	11 000	0,39	* 6208-ZNR	* 6208-ZZNR	SP 80
	90	23	42,3	24	1,02	17 000	11 000	0,65	* 6308-ZNR	* 6308-ZZNR	SP 90
45	85	19	35,1	21,6	0,915	17 000	11 000	0,43	* 6209-ZNR	* 6209-ZZNR	SP 85
	100	25	55,3	31,5	1,34	15 000	9 500	0,87	* 6309-ZNR	* 6309-ZZNR	SP 100
50	90	20	37,1	23,2	0,98	15 000	10 000	0,48	* 6210-ZNR	* 6210-ZZNR	SP 90
	110	27	65	38	1,6	13 000	8 500	1,1	* 6310-ZNR	* 6310-ZZNR	SP 110
55	100	21	46,2	29	1,25	14 000	9 000	0,64	* 6211-ZNR	* 6211-ZZNR	SP 100
	120	29	74,1	45	1,9	12 000	8 000	1,45	* 6311-ZNR	* 6311-ZZNR	SP 120
60	110	22	55,3	36	1,53	13 000	8 000	0,81	* 6212-ZNR	* 6212-ZZNR	SP 110
	130	31	85,2	52	2,2	11 000	7 000	1,8	* 6312-ZNR	* 6312-ZZNR	SP 130

¹⁾ For bearings with a shield on both sides (ZZ), limiting speeds are about 80% of the quoted value.

* SKF Explorer bearing

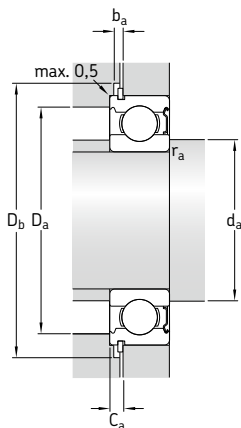

Dimensions										Abutment and fillet dimensions						Calculation factors			
d	d_1	D_2	D_3	D_4	b	f	C	$r_{1,2}$	r_0	d_a	d_a	D_a	D_b	b_a	C_a	r_a	k_r	f_0	
										min.	max.	min.	max.	min.	max.	min.	max.		
mm										mm						-			
10	17	24,8	28,17	34,7	1,35	1,12	2,06	0,6	0,4	14,2	16,9	25,8	36	1,5	3,18	0,6	0,025	13	
12	18,4	27,4	30,15	36,7	1,35	1,12	2,06	0,6	0,4	16,2	18,4	27,8	38	1,5	3,18	0,6	0,025	12	
15	21,7	30,4	33,17	39,7	1,35	1,12	2,06	0,6	0,4	19,2	21,6	30,8	41	1,5	3,18	0,6	0,025	13	
17	24,5	35	38,1	44,6	1,35	1,12	2,06	0,6	0,4	21,2	24,4	35,8	46	1,5	3,18	0,6	0,025	13	
	26,5	39,6	44,6	52,7	1,35	1,12	2,46	1	0,4	22,6	26,4	41,4	54	1,5	3,58	1	0,03	12	
20	27,2	37,2	39,75	46,3	1,35	1,12	2,06	0,6	0,4	23,2	27,1	38,8	48	1,5	3,18	0,6	0,025	14	
	28,8	40,6	44,6	52,7	1,35	1,12	2,46	1	0,4	25,6	28,7	41,4	54	1,5	3,58	1	0,025	13	
	30,3	44,8	49,73	57,9	1,35	1,12	2,46	1,1	0,4	27	30,3	45	59	1,5	3,58	1	0,03	12	
25	32	42,2	44,6	52,7	1,35	1,12	2,06	0,6	0,4	28,2	31,9	43,8	54	1,5	3,18	0,6	0,025	14	
	34,3	46,3	49,73	57,9	1,35	1,12	2,46	1	0,4	30,6	34,3	46,4	59	1,5	3,58	1	0,025	14	
	36,6	52,7	59,61	67,7	1,9	1,7	3,28	1,1	0,6	32	36,5	55	69	2,2	4,98	1	0,03	12	
30	40,3	54,1	59,61	67,7	1,9	1,7	3,28	1	0,6	35,6	40,3	56,4	69	2,2	4,98	1	0,025	14	
	44,6	61,9	68,81	78,6	1,9	1,7	3,28	1,1	0,6	37	44,5	65	80	2,2	4,98	1	0,03	13	
35	46,9	62,7	68,81	78,6	1,9	1,7	3,28	1,1	0,6	42	46,8	65	80	2,2	4,98	1	0,025	14	
	49,5	69,2	76,81	86,6	1,9	1,7	3,28	1,5	0,6	44	49,5	71	88	2,2	4,98	1,5	0,03	13	
40	52,6	69,8	76,81	86,6	1,9	1,7	3,28	1,1	0,6	47	52,5	73	88	2,2	4,98	1	0,025	14	
	56,1	77,7	86,79	96,5	2,7	2,46	3,28	1,5	0,6	49	56	81	98	3	5,74	1,5	0,03	13	
45	57,6	75,2	81,81	91,6	1,9	1,7	3,28	1,1	0,6	52	57,5	78	93	2,2	4,98	1	0,025	14	
	62,1	86,7	96,8	106,5	2,7	2,46	3,28	1,5	0,6	54	62,1	91	108	3	5,74	1,5	0,03	13	
50	62,5	81,7	86,79	96,5	2,7	2,46	3,28	1,1	0,6	57	62,4	83	98	3	5,74	1	0,025	14	
	68,7	95,2	106,81	116,6	2,7	2,46	3,28	2	0,6	61	68,7	99	118	3	5,74	2	0,03	13	
55	69	89,4	96,8	106,5	2,7	2,46	3,28	1,5	0,6	64	69	91	108	3	5,74	1,5	0,025	14	
	75,3	104	115,21	129,7	3,1	2,82	4,06	2	0,6	66	75,2	109	131	3,5	6,88	2	0,03	13	
60	75,5	98	106,81	116,6	2,7	2,46	3,28	1,5	0,6	69	75,4	101	118	3	5,74	1,5	0,025	14	
	81,8	113	125,22	139,7	3,1	2,82	4,06	2,1	0,6	72	81,8	118	141	3,5	6,88	2	0,03	13	

1.5 Single row deep groove ball bearings with a snap ring and shields

d 65 – 70 mm

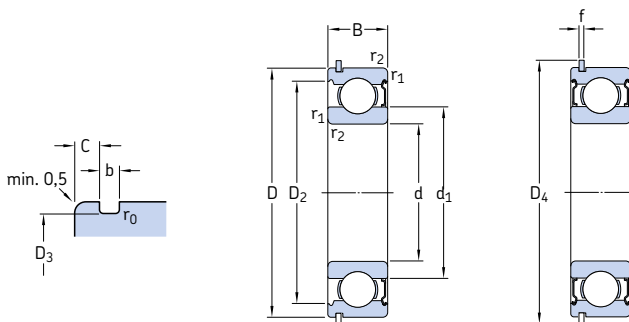

ZNR

2ZNR

Principal dimensions			Basic load ratings dynamic static		Fatigue load limit	Speed ratings Reference speed Limiting speed ¹⁾		Mass	Designations Bearing with a snap ring and a shield on one side a shield on both sides		Snap ring
d	D	B	C	C ₀	P _u						
mm			kN		kN	r/min		kg	-		
65	120	23	58,5	40,5	1,73	12 000	7 500	1,05	* 6213-ZNR	* 6213-2ZNR	SP 120
	140	33	97,5	60	2,5	10 000	6 700	2,2	* 6313-ZNR	* 6313-2ZNR	SP 140
70	125	24	63,7	45	1,9	11 000	7 000	1,15	* 6214-ZNR	* 6214-2ZNR	SP 125
	150	35	111	68	2,75	9 500	6 300	2,65	* 6314-ZNR	* 6314-2ZNR	SP 150

¹⁾ For bearings with a shield on both sides (2Z), limiting speeds are about 80% of the quoted value.

* SKF Explorer bearing

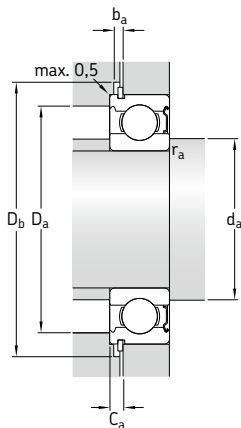

Dimensions										Abutment and fillet dimensions							Calculation factors		
d	d_1	D_2	D_3	D_4	b	f	C	$r_{1,2}$	r_0	d_a	d_a	D_a	D_b	b_a	C_a	r_a	k_f	f_0	
										min.	max.	min.	max.	min.	max.	min.	max.		
mm										mm							-		
65	83,3	106	115,21	129,7	3,1	2,82	4,06	1,5	0,6	74	83,2	111	131	3,5	6,88	1,5	0,025	15	
	88,3	122	135,23	149,7	3,1	2,82	4,9	2,1	0,6	77	88,3	128	151	3,5	7,72	2	0,03	13	
70	87	111	120,22	134,7	3,1	2,82	4,06	1,5	0,6	79	87	116	136	3,5	6,88	1,5	0,025	15	
	94,9	130	145,25	159,7	3,1	2,82	4,9	2,1	0,6	82	94,9	138	162	3,5	7,72	2	0,03	13	

1.6 Stainless steel deep groove ball bearings d 0,6 – 5 mm

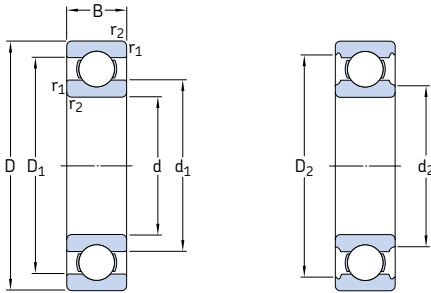

Principal dimensions			Basic load ratings		Fatigue load limit	Speed ratings		Mass	Designation
d	D	B	dynamic	static		Reference speed	Limiting speed		
mm			C	C ₀	P _u	r/min		g	-
0,6	2,5	1	0,034	0,007	0	260 000	160 000	0,02	W 618/0.6
1	3	1	0,052	0,012	0,001	240 000	150 000	0,03	W 618/1
	3	1,5	0,052	0,012	0,001	240 000	150 000	0,1	W 638/1
	4	1,6	0,092	0,018	0,001	220 000	140 000	0,1	W 619/1
1,5	4	1,2	0,062	0,016	0,001	220 000	140 000	0,1	W 618/1.5
	5	2	0,135	0,036	0,002	200 000	120 000	0,2	W 619/1.5
	6	2,5	0,19	0,051	0,002	180 000	110 000	0,38	W 60/1.5
2	4	1,2	0,068	0,019	0,001	200 000	130 000	0,1	W 617/2
	5	1,5	0,094	0,025	0,001	200 000	120 000	0,15	W 618/2
	5	2	0,094	0,025	0,001	200 000	120 000	0,16	W 618/2 X
	6	2,3	0,19	0,051	0,002	180 000	110 000	0,28	W 619/2
	6	2,5	0,19	0,051	0,002	180 000	110 000	0,3	W 619/2 X
	7	2,8	0,221	0,067	0,003	160 000	100 000	0,5	W 602
2,5	6	1,8	0,117	0,036	0,002	170 000	110 000	0,2	W 618/2.5
	7	2,5	0,221	0,067	0,003	160 000	100 000	0,4	W 619/2.5
	8	2,8	0,312	0,088	0,004	160 000	95 000	0,6	W 60/2.5
3	6	2	0,117	0,036	0,002	170 000	110 000	0,2	W 617/3
	7	2	0,178	0,057	0,002	160 000	100 000	0,34	W 618/3
	8	3	0,319	0,09	0,004	150 000	95 000	0,7	W 619/3
	9	3	0,325	0,095	0,004	140 000	90 000	0,8	W 603
	10	4	0,358	0,11	0,005	140 000	90 000	1,6	W 623
	13	5	0,741	0,25	0,011	110 000	70 000	3,1	W 633
4	7	2	0,178	0,057	0,003	150 000	95 000	0,2	W 617/4
	8	2	0,225	0,072	0,003	150 000	90 000	0,4	W 617/4 X
	9	2,5	0,364	0,114	0,005	140 000	85 000	0,6	W 618/4
	10	3	0,553	0,245	0,011	130 000	80 000	1	W 637/4 X
	11	4	0,54	0,176	0,008	130 000	80 000	2	W 619/4
	12	4	0,54	0,176	0,008	130 000	80 000	2	W 604
5	13	5	0,741	0,25	0,011	110 000	70 000	2,8	W 624
	16	5	0,761	0,265	0,011	100 000	63 000	5	W 634
	8	2	0,174	0,061	0,003	140 000	85 000	0,3	W 617/5
	9	2,5	0,247	0,085	0,004	130 000	85 000	0,5	W 627/5 X
	11	3	0,403	0,143	0,006	120 000	75 000	1,2	W 618/5
13	4	0,761	0,335	0,014	110 000	70 000	2,4	W 619/5	

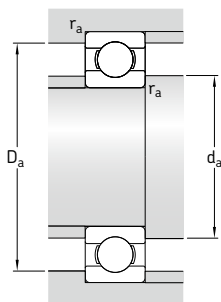

Dimensions						Abutment and fillet dimensions			Calculation factors	
d	d ₁	d ₂	D ₁	D ₂	r _{1,2} min.	d _a min.	D _a max.	r _a max.	k _r	f ₀
mm	mm	mm	mm	mm	mm	mm	mm	mm	-	-
0,6	1,1	-	2	-	0,05	1	2,1	0,05	0,02	5,7
1	1,5	-	2,5	-	0,05	1,4	2,6	0,05	0,02	5,6
	1,5	-	2,5	-	0,05	1,4	2,6	0,05	0,02	5,6
	2	-	3,2	-	0,1	1,8	3,3	0,1	0,025	5,8
1,5	2,1	-	3,1	-	0,05	1,9	3,6	0,05	0,02	6,4
	2,5	-	4	-	0,15	2,4	4,1	0,15	0,025	5,9
	3	-	4,8	-	0,15	2,7	4,9	0,15	0,03	6
2	2,5	-	3,5	-	0,05	2,4	3,6	0,05	0,015	6,7
	2,7	-	3,9	-	0,08	2,5	4,4	0,08	0,02	6,5
	2,7	-	3,9	-	0,1	2,6	4,2	0,1	0,02	6,5
	3	-	4,8	-	0,15	2,9	4,9	0,15	0,025	6
	3	-	4,8	-	0,15	2,9	4,9	0,15	0,025	6
	3,8	-	5,7	-	0,15	3,2	5,8	0,15	0,03	6,6
2,5	3,7	-	4,9	-	0,08	3,1	5,4	0,08	0,02	7,1
	3,8	-	5,7	-	0,15	3,7	5,8	0,15	0,025	6,6
	4,1	-	6,4	-	0,15	3,7	6,8	0,15	0,03	5,9
3	3,7	-	4,9	-	0,1	3,6	5,2	0,1	0,015	7,1
	4,2	-	5,8	-	0,1	3,8	6,2	0,1	0,02	7,1
	4,3	-	6,7	-	0,15	4,2	6,8	0,15	0,025	6,1
	4,8	-	7,2	-	0,15	4,2	7,8	0,15	0,03	6,4
	-	4,3	8	0,15	4,2	8,8	0,15	0,03	6,3	6,3
	-	6	10,5	11,4	0,2	4,6	11,5	0,2	0,035	6,4
4	4,7	-	6,3	-	0,1	4,6	6,4	0,1	0,015	7,3
	5	-	6,8	-	0,15	4,9	6,9	0,15	0,015	7,2
	5,2	-	7,5	-	0,1	4,8	8,2	0,1	0,02	6,5
	5,9	-	8,2	-	0,2	5,6	8,4	0,2	0,02	12
	-	5,6	9	9,9	0,15	5,2	10	0,15	0,025	6,4
	-	5,6	9	9,9	0,2	5,3	10,4	0,2	0,03	6,4
	-	6	10,5	11,4	0,2	5,6	11,5	0,2	0,03	6,4
	-	6,7	11,7	13	0,3	6	14	0,3	0,035	6,8
	-	6,7	11,7	13	0,3	6	14	0,3	0,035	6,8
5	5,7	-	7,3	-	0,1	5,6	7,4	0,1	0,015	7,7
	6	-	7,8	-	0,15	5,9	7,9	0,15	0,015	7,6
	6,8	-	9,2	-	0,15	6,2	9,8	0,15	0,02	7,1
	-	6,6	10,5	11,2	0,2	6,3	11,4	0,2	0,025	11
	-	6,6	10,5	11,2	0,2	6,3	11,4	0,2	0,025	11

1.6 Stainless steel deep groove ball bearings d 5 – 10 mm

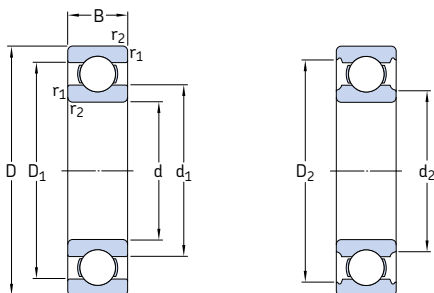

Principal dimensions			Basic load ratings		Fatigue load limit	Speed ratings		Mass	Designation
d	D	B	dynamic	static		Reference speed	Limiting speed		
mm			C	C ₀	P _u	r/min		g	-
5 cont.	14	5	0,761	0,26	0,011	110 000	67 000	3,1	W 605
	16	5	1,43	0,63	0,027	100 000	63 000	4,6	W 625
	19	6	2,34	0,88	0,038	85 000	56 000	7,5	W 635
6	10	2,5	0,286	0,112	0,005	120 000	75 000	0,6	W 617/6
	12	3	0,403	0,146	0,006	110 000	70 000	1,3	W 627/6 X
	13	3,5	0,618	0,224	0,01	110 000	67 000	1,9	W 618/6
	15	5	0,761	0,265	0,011	100 000	63 000	3,6	W 619/6
	17	6	1,95	0,83	0,036	95 000	60 000	5,5	W 606
	19	6	1,53	0,585	0,025	85 000	56 000	7,2	W 626
7	22	7	2,34	0,8	0,034	75 000	48 000	12	W 636
	11	2,5	0,26	0,104	0,004	110 000	70 000	0,6	W 617/7
	13	3	0,312	0,143	0,006	100 000	63 000	1,6	W 627 X
	14	3,5	0,663	0,26	0,011	100 000	63 000	2,1	W 618/7
	17	5	0,923	0,365	0,016	90 000	56 000	4,9	W 619/7
	19	6	1,53	0,585	0,025	85 000	56 000	6,8	W 607
8	22	7	1,99	0,78	0,034	75 000	48 000	11,5	W 627
	26	9	3,97	1,96	0,083	67 000	40 000	22,5	W 637
	12	2,5	0,312	0,14	0,006	100 000	63 000	0,7	W 617/8
	14	3,5	0,462	0,193	0,008	95 000	60 000	1,9	W 637/8 X
	16	4	0,715	0,3	0,012	90 000	56 000	3,2	W 618/8
	19	6	1,25	0,455	0,02	85 000	53 000	6,3	W 619/8
9	22	7	1,99	0,78	0,034	75 000	48 000	11	W 608
	24	8	2,47	1,12	0,048	70 000	45 000	16,5	W 628
	28	9	3,97	1,96	0,083	67 000	40 000	27,5	W 638
	14	3	0,52	0,236	0,01	95 000	60 000	1,2	W 617/9
	17	4	0,761	0,335	0,014	85 000	53 000	3,5	W 618/9
10	20	6	2,12	1,06	0,045	80 000	50 000	7,2	W 619/9
	24	7	2,03	0,815	0,036	70 000	43 000	13,5	W 609
	26	8	3,97	1,96	0,083	67 000	40 000	18	W 629
	30	10	4,94	2,32	0,1	60 000	36 000	33,5	W 639
	15	3	0,488	0,22	0,009	85 000	56 000	1,4	W 61700
	19	5	1,48	0,83	0,036	80 000	48 000	4,8	W 61800
10	19	7	1,48	0,83	0,036	80 000	48 000	6,8	W 63800
	22	6	2,7	1,27	0,054	70 000	45 000	8,9	W 61900

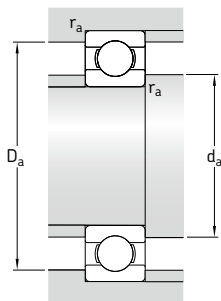

Dimensions						Abutment and fillet dimensions			Calculation factors	
d	d ₁	d ₂	D ₁	D ₂	r _{1,2} min.	d _a min.	D _a max.	r _a max.	k _r	f ₀
mm	mm	mm	mm	mm	mm	mm	mm	mm		
5	–	6,9	11,3	12,2	0,2	6,6	12,4	0,2	0,03	6,6
	–	7,5	12,5	13,4	0,3	7	14	0,3	0,03	12
	–	8,5	15,1	16,5	0,3	7	17	0,3	0,035	12
6	7	–	8,9	–	0,15	6,9	9	0,15	0,015	7,9
	7,7	–	10,2	–	0,2	7,6	10,4	0,2	0,015	7,4
	8	–	11	–	0,15	7,2	11,8	0,15	0,02	7
	–	7,5	11,7	13	0,2	7,3	13,4	0,2	0,025	6,8
	–	8,2	13,8	14,8	0,3	8	15	0,3	0,03	11
	–	8,5	15,1	16,5	0,3	8	17	0,3	0,03	7,9
–	10,5	18,1	19,1	0,3	8	20	0,3	0,035	7,2	
7	8	–	10	–	0,15	7,9	10,1	0,15	0,015	8,1
	9,3	–	11,2	–	0,2	8,6	11,4	0,2	0,03	8,3
	9	–	12	–	0,15	8,2	12,8	0,15	0,02	7,2
	–	9,2	13,6	14,3	0,3	9	15	0,3	0,025	7,3
	–	9	15,1	16,5	0,3	8,7	17	0,3	0,03	7,9
	–	10,5	18	19,1	0,3	9	20	0,3	0,03	7,2
–	13,9	21,3	22,4	0,3	9	24	0,3	0,035	12	
8	9	–	10,9	–	0,15	8,9	11	0,15	0,015	8,2
	9,8	–	12,2	–	0,2	9,6	12,4	0,2	0,02	7,8
	10,5	–	13,5	–	0,2	9,6	14,4	0,2	0,02	7,5
	–	9,8	15,5	16,7	0,3	9,7	17	0,3	0,025	6,6
	–	10,5	18	19,1	0,3	10	20	0,3	0,03	7,2
	–	11,9	18,7	19,9	0,3	10	22	0,3	0,03	10
–	13,9	21,3	22,4	0,3	10	26	0,3	0,035	12	
9	10,3	–	12,7	13,2	0,1	9,8	13,3	0,1	0,015	7,8
	11,5	–	14,5	–	0,2	10,6	15,4	0,2	0,02	7,7
	11,6	–	16,2	17,5	0,3	11	18	0,3	0,025	13
	–	12,1	19,5	20,5	0,3	11	22	0,3	0,03	7,5
	–	13,9	21,3	22,4	0,6	13	22,6	0,6	0,03	12
	–	15,3	23,8	25,3	0,6	13	26	0,6	0,035	13
10	11,2	–	13,6	–	0,15	11	14,5	0,15	0,015	8
	–	11,8	16,3	17,2	0,3	11,5	17,5	0,3	0,02	15
	–	11,8	16,3	17,2	0,3	11,5	17,5	0,3	0,02	15
	–	13,2	18,2	19,4	0,3	12	20	0,3	0,025	14

1.6 Stainless steel deep groove ball bearings d 10 – 20 mm

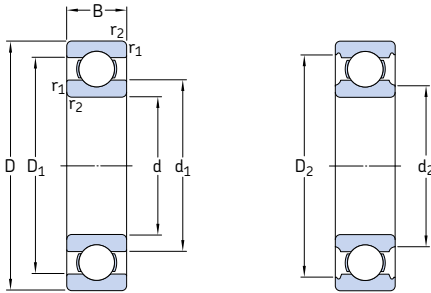

Principal dimensions			Basic load ratings		Fatigue load limit	Speed ratings		Mass	Designation	
d	D	B	dynamic	static		Reference speed	Limiting speed			
mm			C	C ₀	P _u	r/min		g	-	
10 cont.	26	8	3,97	1,96	0,083	67 000	40 000	17,5	W 6000	
	30	9	4,36	2,32	0,1	60 000	36 000	29	W 6200	
	35	11	7,02	3,4	0,146	53 000	34 000	50,5	W 6300	
12	18	4	0,527	0,265	0,011	75 000	48 000	2,7	W 61701	
	21	5	1,51	0,9	0,039	70 000	43 000	5,4	W 61801	
	21	7	1,51	0,9	0,039	70 000	43 000	7,6	W 63801	
	24	6	2,51	1,46	0,062	67 000	40 000	10,5	W 61901	
	28	8	4,42	2,36	0,102	60 000	36 000	18,5	W 6001	
	32	10	5,72	3	0,127	53 000	34 000	34,5	W 6201	
	37	12	9,75	4,15	0,176	48 000	30 000	56,5	W 6301	
	15	21	4	0,527	0,29	0,012	67 000	40 000	3,3	W 61702
		24	5	1,65	1,08	0,048	60 000	38 000	6,4	W 61802
		24	7	1,65	1,08	0,048	60 000	38 000	9,1	W 63802
28		7	3,71	2,24	0,095	56 000	34 000	15	W 61902	
32		9	4,88	2,8	0,12	50 000	32 000	27,5	W 6002	
35		11	6,37	3,6	0,156	48 000	30 000	42	W 6202	
17	42	13	9,95	5,4	0,232	40 000	26 000	78,5	W 6302	
	23	4	0,559	0,34	0,015	60 000	38 000	3,6	W 61703	
	26	5	1,78	1,27	0,054	56 000	34 000	7,3	W 61803	
	26	7	1,78	1,27	0,054	56 000	34 000	10	W 63803	
	30	7	3,97	2,55	0,108	50 000	32 000	16	W 61903	
	35	10	4,94	3,15	0,137	45 000	28 000	36,5	W 6003	
	40	12	8,06	4,75	0,2	40 000	26 000	62	W 6203	
	47	14	11,7	6,55	0,28	36 000	22 000	109	W 6303	
	20	27	4	0,676	0,39	0,017	50 000	32 000	5,4	W 61704
		32	7	3,12	2,08	0,09	48 000	30 000	16	W 61804
32		10	3,12	2,08	0,09	48 000	30 000	23	W 63804	
37		9	5,53	3,65	0,156	43 000	26 000	33	W 61904	
42		12	9,36	5,1	0,212	38 000	24 000	62	W 6004	
47		14	12,5	6,55	0,28	34 000	22 000	102	W 6204	
52		15	13,8	7,8	0,335	34 000	20 000	140	W 6304	

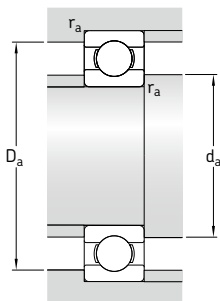

Dimensions						Abutment and fillet dimensions			Calculation factors	
d	d ₁	d ₂	D ₁	D ₂	r _{1,2} min.	d _a min.	D _a max.	r _a max.	k _r	f ₀
mm	mm	mm	mm	mm	mm	mm	mm	mm	-	-
10	-	13,9	21,3	22,4	0,3	12	24	0,3	0,03	12
	-	15,3	23,8	25,3	0,6	14	26	0,6	0,03	13
	17,7	-	27,4	29,3	0,6	14	31	0,6	0,035	11
12	13,8	-	16,1	16,7	0,2	13,5	17	0,2	0,015	8,2
	-	13,8	18,3	19,2	0,3	13,5	19,5	0,3	0,02	13
	-	13,8	18,3	19,2	0,3	13,5	19,5	0,3	0,02	13
	-	15,3	20,3	21,4	0,3	14	22	0,3	0,025	15
	-	16	23,6	25,2	0,3	14	26	0,3	0,03	13
	18,5	-	26,2	28	0,6	16	28,5	0,6	0,03	12
15	19,3	-	29,9	32	1	17	32,5	1	0,035	11
	16,8	-	19,1	19,7	0,2	16,5	20	0,2	0,015	8,4
	-	16,8	21,3	22,2	0,3	16,5	22,5	0,3	0,02	14
	-	16,8	21,3	22,2	0,3	16,5	22,5	0,3	0,02	14
	-	18,8	24,2	25,3	0,3	17	26	0,3	0,025	14
	21,7	-	34,9	36,8	1	20	37,5	1	0,035	12
17	24,5	-	29,5	31,4	0,6	19	32	0,6	0,03	13
	24,5	-	34,9	36,8	1	20	37,5	1	0,035	12
	18,8	-	21,1	21,7	0,2	18,5	22	0,2	0,015	8,5
	-	18,8	23,3	24,2	0,3	18,5	24,5	0,3	0,02	14
	-	18,8	23,3	24,2	0,3	18,5	24,5	0,3	0,02	14
	21	-	26,8	27,8	0,3	19	28,5	0,3	0,025	15
20	23,5	-	30,1	31,9	0,3	19	33	0,3	0,03	14
	24,9	-	33,6	35,8	0,6	21	37,5	0,6	0,03	13
	27,5	-	38,9	41,1	1	22	42	1	0,035	12
	22,3	-	24,6	25,5	0,2	21,5	26	0,2	0,015	8,7
	-	22,6	28,2	29,6	0,3	22	30,5	0,3	0,02	13
	-	22,6	28,2	29,6	0,3	22	30,5	0,3	0,02	13
20	-	23,6	32	33,5	0,3	22	35	0,3	0,025	15
	27,6	-	35,7	38,8	0,6	24	39,5	0,6	0,03	14
	29,5	-	39,5	41	1	25	42	1	0,03	13
	30	-	41,7	45,4	1,1	26,5	46	1	0,035	12

1.6 Stainless steel deep groove ball bearings d 25 – 50 mm

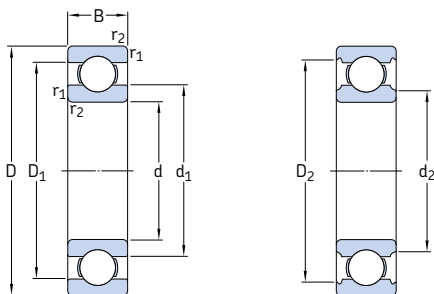

Principal dimensions			Basic load ratings		Fatigue load limit	Speed ratings		Mass	Designation
d	D	B	dynamic	static		Reference speed	Limiting speed		
mm			C	C ₀	P _u	r/min		g	-
25	32	4	0,715	0,465	0,02	43 000	26 000	6,5	W 61705
	37	7	3,9	2,55	0,108	38 000	24 000	20	W 61805
	37	10	3,9	2,55	0,108	38 000	24 000	28,5	W 63805
	42	9	6,05	4,5	0,193	34 000	22 000	39,5	W 61905
47	12	10,1	5,85	0,25	0,25	32 000	20 000	73	W 6005
	15	13,8	7,8	0,335	0,335	30 000	19 000	125	W 6205
	17	20,8	11,2	0,48	0,48	26 000	17 000	228	W 6305
30	37	4	0,65	0,53	0,022	36 000	22 000	7,6	W 61706
	42	7	3,58	2,9	0,125	34 000	20 000	23	W 61806
	42	10	3,58	2,9	0,125	34 000	20 000	35	W 63806
	47	9	6,24	5	0,212	30 000	19 000	44,5	W 61906
55	13	13,3	8,3	0,355	0,355	28 000	17 000	108	W 6006
	16	19	11,4	0,48	0,48	26 000	16 000	188	W 6206
	19	22,9	15	0,64	0,64	22 000	14 000	340	W 6306
35	44	5	1,06	0,915	0,039	30 000	19 000	14	W 61707
	47	7	3,71	3,35	0,14	30 000	18 000	27	W 61807
	55	10	9,36	7,65	0,325	26 000	16 000	70	W 61907
	62	14	13,8	10,2	0,44	24 000	15 000	141	W 6007
	72	17	22,1	15,3	0,655	22 000	14 000	268	W 6207
	80	21	28,6	19	0,815	20 000	13 000	447	W 6307
40	50	6	1,43	1,27	0,054	26 000	16 000	21,5	W 61708
	52	7	4,49	3,75	0,16	26 000	16 000	29,5	W 61808
	62	12	11,9	9,8	0,425	24 000	14 000	105	W 61908
	68	15	14,6	11,4	0,49	22 000	14 000	177	W 6008
	80	18	25,1	17,6	0,75	20 000	12 000	345	W 6208
45	55	6	1,46	1,37	0,06	24 000	15 000	23,5	W 61709
	58	7	5,72	5	0,212	24 000	14 000	34,5	W 61809
	68	12	14	10,8	0,465	20 000	13 000	118	W 61909
	75	16	18,2	15	0,64	20 000	12 000	229	W 6009
	85	19	28,1	20,4	0,865	18 000	11 000	377	W 6209
50	62	6	1,53	1,53	0,067	22 000	13 000	35	W 61710
	65	7	5,07	5,5	0,236	20 000	13 000	48	W 61810
	72	12	12,5	11,6	0,5	19 000	12 000	132	W 61910
	80	16	19	16,6	0,71	18 000	11 000	246	W 6010
	90	20	30,2	23,2	0,98	17 000	10 000	428	W 6210

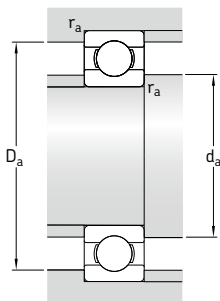

Dimensions						Abutment and fillet dimensions			Calculation factors	
d	d ₁	d ₂	D ₁	D ₂	r _{1,2} min.	d _a min.	D _a max.	r _a max.	k _r	f ₀
mm						mm				
25	27,3	–	29,7	30,3	0,2	26,5	31	0,2	0,015	8,8
	28,2	–	33,2	34,2	0,3	27	35	0,3	0,02	14
	28,2	–	33,2	34,2	0,3	27	35	0,3	0,02	14
	30,9	–	37,5	39,5	0,3	27	40,5	0,3	0,025	15
	31,7	–	40,3	42,8	0,6	29	44,5	0,6	0,03	15
30	34	–	44,2	45,8	1	30	47	1	0,03	14
	38,1	–	51	53,3	1,1	31,5	55,5	1	0,035	13
	32,4	–	34,7	35,7	0,2	31,5	36	0,2	0,015	8,9
	33,1	–	38,2	39,2	0,3	32	40	0,3	0,02	14
	33,1	–	38,2	39,2	0,3	32	40	0,3	0,02	14
35	35,1	–	42	44,1	0,3	32	45	0,3	0,025	16
	38	–	47,3	50	1	35	50,5	1	0,03	15
	40,7	–	52,9	55,2	1	35	57	1	0,03	14
	44,9	–	59,3	62,4	1,1	36,5	65,5	1	0,035	13
	38	–	41,1	42,2	0,3	37	42,5	0,3	0,015	8,9
40	38,2	–	42,8	43,7	0,3	37	45	0,3	0,02	14
	42,2	–	50,1	52,2	0,6	39	52,5	0,6	0,025	16
	44	–	54,3	57,1	1	40	57,5	1	0,03	15
	47,6	–	61,6	64,9	1,1	41,5	65,5	1	0,03	14
	–	46,7	66,7	71,6	1,5	43	73,5	1,5	0,035	13
45	43,3	–	46,8	47,9	0,3	42	48,5	0,3	0,015	9
	43,2	–	48,1	49	0,3	42	50	0,3	0,02	15
	46,9	–	55,6	57,6	0,6	44	59,5	0,6	0,025	16
	49,2	–	59,6	62,5	1	45	63,5	1	0,03	15
	–	50,1	67,2	70,8	1,1	46,5	73,5	1	0,03	14
50	48,3	–	51,8	53,2	0,3	47	53,5	0,3	0,015	9,1
	48,2	–	54	54,9	0,3	47	56	0,3	0,02	15
	52,4	–	61,2	63,2	0,6	49	64	0,6	0,025	16
	54,5	–	65,8	69	1	50	70	1	0,03	15
	–	53,5	72,9	76,4	1,1	51,5	78,5	1	0,03	14
55	54,3	–	57,8	59,2	0,3	52	60	0,3	0,015	9,2
	54,6	–	60,3	61,6	0,3	52	63	0,3	0,02	15
	56,8	–	65,6	67,9	0,6	54	68,5	0,6	0,025	16
	60	–	71	74,6	1	55	75,5	1	0,03	16
	–	60	78,1	82,2	1,1	56,5	83,5	1	0,03	14

1.7 Capped stainless steel deep groove ball bearings d 1,5 – 4 mm

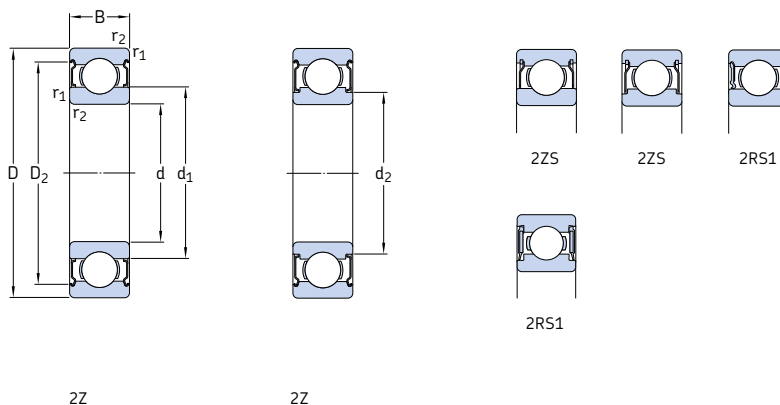

Principal dimensions			Basic load ratings		Fatigue load limit	Speed ratings		Mass	Designation
d	D	B	dynamic	static		Reference speed	Limiting speed		
mm			C	C ₀	P _u	r/min	g	-	
1,5	4	2	0,062	0,016	0,001	220 000	110 000	0,14	W 638/1,5-2Z
	5	2,6	0,135	0,036	0,002	200 000	100 000	0,25	W 639/1,5-2Z
	6	3	0,19	0,051	0,002	180 000	90 000	0,42	W 630/1,5-2Z
2	4	2	0,068	0,019	0,001	200 000	100 000	0,09	W 637/2-2Z
	5	2,3	0,094	0,025	0,001	200 000	100 000	0,2	W 638/2-2Z
	5	2,5	0,094	0,025	0,001	200 000	100 000	0,2	W 638/2 X-2Z
	6	2,3	0,094	0,025	0,001	200 000	100 000	0,35	W 619/2-2Z
	6	2,5	0,19	0,051	0,002	180 000	90 000	0,31	W 619/2 X-2Z
	6	3	0,19	0,051	0,002	180 000	90 000	0,35	W 639/2-2Z
	7	3	0,221	0,067	0,003	160 000	80 000	0,5	W 602 X-2ZS
	7	3,5	0,221	0,067	0,003	160 000	80 000	0,6	W 630/2-2ZS
	7,5	4	0,221	0,067	0,003	160 000	80 000	0,73	W 60/2,5-2Z
2,5	6	2,6	0,117	0,036	0,002	170 000	85 000	0,35	W 638/2,5-2Z
	7	3,5	0,221	0,067	0,003	160 000	80 000	0,55	W 639/2,5-2ZS
	8	2,8	0,178	0,057	0,002	160 000	80 000	0,73	W 60/2,5-2Z
	8	4	0,312	0,088	0,004	160 000	80 000	0,85	W 630/2,5-2Z
	9	4	0,312	0,088	0,004	160 000	80 000	0,85	W 630/2,5-2Z
3	6	2,5	0,117	0,036	0,002	170 000	85 000	0,25	W 627/3-2Z
	7	3	0,178	0,057	0,002	160 000	80 000	0,5	W 638/3-2Z
	7	3	0,178	0,057	0,002	-	45 000	0,5	W 638/3-2RS1
	8	3	0,26	0,072	0,003	150 000	75 000	0,6	W 619/3-2Z
	8	4	0,319	0,09	0,004	150 000	75 000	0,83	W 639/3-2Z
	8	4	0,319	0,09	0,004	-	43 000	0,83	W 639/3-2RS1
	9	4	0,377	0,095	0,004	140 000	70 000	1	W 603 X-2Z
	9	5	0,325	0,095	0,004	140 000	70 000	1	W 630/3-2Z
	10	4	0,358	0,11	0,005	-	40 000	1,7	W 623-2RS1
	10	4	0,358	0,11	0,005	140 000	70 000	1,7	W 623-2Z
	13	5	0,741	0,25	0,011	-	32 000	3,3	W 633-2RS1
	13	5	0,741	0,25	0,011	110 000	56 000	3,2	W 633-2Z
	4	7	2,5	0,143	0,053	0,002	150 000	75 000	0,3
7		2,5	0,143	0,053	0,002	150 000	75 000	0,3	W 627/4-2ZS
8		3	0,225	0,072	0,003	150 000	75 000	0,5	W 637/4 X-2Z
9		4	0,364	0,114	0,005	140 000	70 000	0,9	W 638/4-2Z
9		4	0,364	0,114	0,005	-	40 000	1	W 638/4-2RS1
9		4	0,364	0,114	0,005	-	40 000	1	W 638/4-2RS1

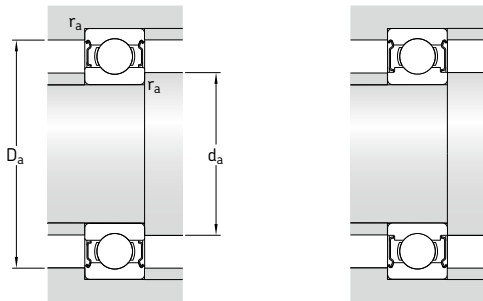

Dimensions

Abutment and fillet dimensions

Calculation factors

d	d ₁	d ₂	D ₂	r _{1,2}	d _a	d _a	D _a	r _a	k _r	f ₀	
mm	~	~	~	min.	min.	max.	max.	max.	-	-	
1.5	2,1	-	3,5	0,05	1,9	2,1	3,6	0,05	0,02	6,4	
	2,5	-	4,5	0,15	2,4	2,5	4,5	0,15	0,025	5,9	
	3	-	5,4	0,15	2,7	2,9	5,4	0,15	0,03	6	
2	2,5	-	3,7	0,05	2,4	2,5	3,8	0,05	0,02	6,7	
	2,7	-	4,4	0,08	2,5	2,6	4,5	0,08	0,02	6,5	
	2,7	-	4,4	0,1	2,6	2,6	4,5	0,1	0,02	6,5	
	2,7	-	4,4	0,15	2,6	2,6	4,8	0,15	0,025	6,5	
	3	-	5,4	0,15	2,9	2,9	5,4	0,15	0,025	6	
	3	-	5,4	0,15	2,9	2,9	5,4	0,15	0,025	6	
	-	3,1	6,2	0,15	3	3,1	6,2	0,15	0,03	6,6	
	-	3,1	6,2	0,15	3	3,1	6,2	0,15	0,03	6,6	
	2,5	3,7	-	5,4	0,08	3,1	3,6	5,5	0,08	0,02	7,1
	3,8	-	6,2	0,15	3,7	3,8	6,2	0,15	0,025	6,6	
2,5	-	3,8	6,4	0,15	3,7	3,8	6,8	0,15	0,03	7,1	
	4,1	-	7,1	0,15	3,7	4	7,2	0,15	0,03	5,9	
3	3,7	-	5,4	0,1	3,6	3,6	5,5	0,1	0,015	7,1	
	-	3,8	6,4	0,1	3,7	3,8	6,5	0,1	0,02	7,1	
	-	3,8	6,4	0,1	3,7	3,8	6,5	0,1	0,02	7,1	
	5	-	7,4	0,1	3,8	4,9	7,5	0,1	0,025	7,2	
	4,3	-	7,3	0,15	4,2	4,3	7,3	0,15	0,025	6,1	
	4,3	-	7,3	0,15	4,2	4,3	7,3	0,15	0,025	6,1	
	-	4,3	7,9	0,15	4,2	4,3	8	0,15	0,03	6,4	
	-	4,3	7,9	0,15	4,2	4,3	8	0,15	0,03	6,4	
	-	4,3	8	0,15	4,2	4,3	8,8	0,15	0,03	6,3	
	-	4,3	8	0,15	4,2	4,3	8,8	0,15	0,03	6,3	
	-	6	11,4	0,2	4,6	5,9	11,5	0,2	0,035	6,4	
	-	6	11,4	0,2	4,6	5,9	11,5	0,2	0,035	6,4	
	4	4,8	-	6,5	0,1	4,6	4,7	6,5	0,1	0,015	7,6
4,8		-	6,3	0,1	4,6	4,7	6,4	0,1	0,015	7,6	
5		-	7,4	0,1	4,8	4,9	7,5	0,1	0,02	7,2	
5,2		-	8,1	0,1	4,8	5,1	8,2	0,1	0,02	6,5	
5,2		-	8,1	0,1	4,8	5,1	8,2	0,1	0,02	6,5	
5,2		-	8,1	0,1	4,8	5,1	8,2	0,1	0,02	6,5	

1.7 Capped stainless steel deep groove ball bearings d 4 – 6 mm

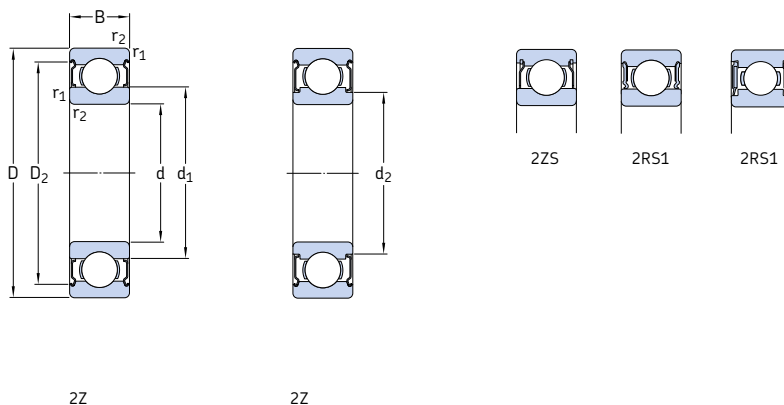

Principal dimensions			Basic load ratings		Fatigue load limit	Speed ratings		Mass	Designation	
d	D	B	dynamic	static		Reference speed	Limiting speed			
mm			C	C ₀	P _u	r/min	g	-		
4	10	4	0,637	0,25	0,011	-	36 000	1,4	W 638/4 X-2RS1	
	10	4	0,637	0,25	0,011	130 000	63 000	1,3	W 638/4 X-2Z	
	11	4	0,54	0,176	0,008	130 000	63 000	2,2	W 619/4-2Z	
	11	4	0,54	0,176	0,008	-	36 000	2,2	W 619/4-2RS1	
	12	4	0,54	0,176	0,008	-	36 000	2,1	W 604-2RS1	
	12	4	0,54	0,176	0,008	130 000	63 000	2,2	W 604-2Z	
	13	5	0,741	0,25	0,011	-	32 000	3	W 624-2RS1	
	13	5	0,741	0,25	0,011	110 000	56 000	3	W 624-2Z	
	16	5	0,761	0,265	0,011	-	30 000	5,2	W 634-2RS1	
	16	5	0,761	0,265	0,011	100 000	50 000	5,3	W 634-2Z	
	5	8	2,5	0,14	0,045	0,002	140 000	70 000	0,4	W 627/5-2Z
		8	2,5	0,14	0,045	0,002	140 000	70 000	0,4	W 627/5-2ZS
9		3	0,247	0,085	0,004	130 000	67 000	0,5	W 637/5 X-2Z	
9		3	0,247	0,085	0,004	130 000	67 000	0,6	W 637/5 X-2ZS	
11		4	0,403	0,143	0,006	-	34 000	1,8	W 628/5-2RS1	
11		4	0,403	0,143	0,006	120 000	60 000	1,5	W 628/5-2Z	
11		5	0,403	0,143	0,006	120 000	60 000	1,8	W 638/5-2Z	
11		5	0,403	0,143	0,006	-	34 000	1,8	W 638/5-2RS1	
13		4	0,761	0,335	0,014	110 000	56 000	2,3	W 619/5-2Z	
13		4	0,761	0,335	0,014	-	32 000	2,3	W 619/5-2RS1	
13		5	0,761	0,335	0,014	110 000	56 000	2,9	W 619/5 X-2Z	
14		5	0,761	0,26	0,011	-	30 000	3,4	W 605-2RS1	
14		5	0,761	0,26	0,011	110 000	53 000	3,4	W 605-2Z	
16		5	1,43	0,63	0,027	-	28 000	4,9	W 625-2RS1	
16		5	1,43	0,63	0,027	100 000	50 000	4,8	W 625-2Z	
19		6	2,34	0,88	0,038	85 000	43 000	8	W 635-2Z	
19		6	2,34	0,88	0,038	-	24 000	8	W 635-2RS1	
6		10	3	0,286	0,112	0,005	120 000	60 000	0,7	W 627/6-2Z
	13	5	0,618	0,224	0,01	-	30 000	2,5	W 628/6-2RS1	
	13	5	0,618	0,224	0,01	110 000	53 000	2,5	W 628/6-2Z	
	15	5	0,761	0,265	0,011	-	30 000	3,8	W 619/6-2RS1	
	15	5	0,761	0,265	0,011	100 000	50 000	3,9	W 619/6-2Z	

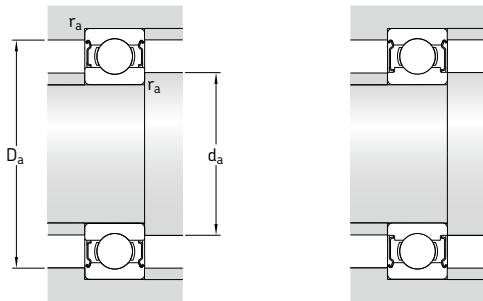

Dimensions

Abutment and fillet dimensions

Calculation factors

d	d ₁ ~	d ₂ ~	D ₂ ~	r _{1,2} min.	d _a min.	d _a max.	D _a max.	r _a max.	k _r	f ₀	
mm					mm				-		
4 cont.	5,9	-	8,8	0,2	5,6	5,8	8,8	0,2	0,02	12	
	5,9	-	8,8	0,2	5,6	5,8	8,8	0,2	0,02	12	
	-	5,6	9,9	0,15	5,2	5,5	10	0,15	0,025	6,4	
	-	5,6	9,9	0,15	5,2	5,5	10	0,15	0,025	6,4	
	-	5,6	9,9	0,2	5,3	5,5	10,4	0,2	0,03	6,4	
	-	5,6	9,9	0,2	5,3	5,5	10,4	0,2	0,03	6,4	
	-	6	11,4	0,2	5,6	5,9	11,5	0,2	0,03	6,4	
	-	6	11,4	0,2	5,6	5,9	11,5	0,2	0,03	6,4	
	-	6,7	13	0,3	6	6,6	14	0,3	0,035	6,8	
	-	6,7	13	0,3	6	6,6	14	0,3	0,035	6,8	
	5	5,8	-	7,5	0,1	5,6	5,7	7,5	0,1	0,015	7,8
		5,8	-	7,4	0,1	5,6	5,7	7,5	0,1	0,015	7,8
6		-	8,4	0,15	5,9	5,9	8,4	0,15	0,02	7,6	
6		-	8,2	0,15	5,9	5,9	8,2	0,15	0,02	7,6	
6,8		-	9,9	0,15	6,2	6,7	10	0,15	0,02	7,1	
6,8		-	9,9	0,15	6,2	6,7	10	0,15	0,02	7,1	
-		6,2	9,9	0,15	5,9	6,1	10	0,15	0,02	7,1	
-		6,2	9,9	0,15	5,9	6,1	10	0,15	0,02	7,1	
-		6,6	11,2	0,2	6,3	6,5	11,4	0,2	0,025	11	
-		6,6	11,2	0,2	6,3	6,5	11,4	0,2	0,025	11	
-		6,6	11,2	0,2	6,3	6,5	11,4	0,2	0,025	11	
-		6,9	12,2	0,2	6,6	6,8	12,4	0,2	0,03	6,6	
-		6,9	12,2	0,2	6,6	6,8	12,4	0,2	0,03	6,6	
-		7,5	13,4	0,3	7	7,4	14	0,3	0,03	12	
-		7,5	13,4	0,3	7	7,4	14	0,3	0,03	12	
-		8,5	16,5	0,3	7	8,4	17	0,3	0,035	12	
-		8,5	16,5	0,3	7	8,4	17	0,3	0,035	12	
6		7	-	9,4	0,1	6,8	6,9	9,5	0,1	0,015	7,8
	-	7,4	11,7	0,15	7,2	7,3	11,8	0,15	0,02	7	
	-	7,4	11,7	0,15	7,2	7,3	11,8	0,15	0,02	7	
	-	7,5	13	0,2	7,3	7,4	13,4	0,2	0,025	6,8	
	-	7,5	13	0,2	7,3	7,4	13,4	0,2	0,025	6,8	

1.7 Capped stainless steel deep groove ball bearings d 6 – 8 mm

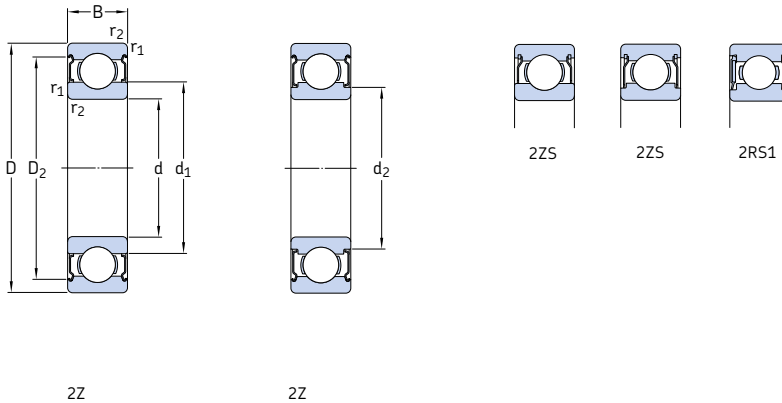

Principal dimensions			Basic load ratings		Fatigue load limit	Speed ratings		Mass	Designation	
d	D	B	dynamic	static		Reference speed	Limiting speed			
mm			C	C ₀	P _u	r/min	g	-		
6 cont.	16	5	0,761	0,265	0,011	-	30 000	4,7	W 619/6 X-2RS1	
	16	5	0,761	0,265	0,011	100 000	50 000	4,8	W 619/6 X-2Z	
	17	6	1,95	0,83	0,036	-	26 000	5,8	W 606-2RS1	
	17	6	1,95	0,83	0,036	95 000	48 000	6	W 606-2Z	
	19	6	1,53	0,585	0,025	-	24 000	7,7	W 626-2RS1	
	19	6	1,53	0,585	0,025	85 000	43 000	7,8	W 626-2Z	
	22	7	2,34	0,8	0,034	-	22 000	13	W 636-2RS1	
	22	7	2,34	0,8	0,034	75 000	38 000	13	W 636-2Z	
	7	11	3	0,302	0,104	0,004	110 000	56 000	0,8	W 627/7-2ZS
		14	5	0,663	0,26	0,011	100 000	50 000	2,8	W 628/7-2Z
14		5	0,663	0,26	0,011	-	28 000	2,8	W 628/7-2RS1	
17		5	0,923	0,365	0,016	90 000	45 000	5,1	W 619/7-2Z	
17		5	0,923	0,365	0,016	-	26 000	5,2	W 619/7-2RS1	
19		6	1,53	0,585	0,025	-	24 000	7,3	W 607-2RS1	
19		6	1,53	0,585	0,025	85 000	43 000	7,4	W 607-2Z	
22		7	1,99	0,78	0,034	-	22 000	12,5	W 627-2RS1	
22		7	1,99	0,78	0,034	75 000	38 000	12,5	W 627-2Z	
26		9	3,97	1,96	0,083	-	19 000	23,5	W 637-2RS1	
26	9	3,97	1,96	0,083	67 000	32 000	24	W 637-2Z		
8	12	3,5	0,312	0,14	0,006	100 000	53 000	1,1	W 637/8-2Z	
	12	3,5	0,312	0,14	0,006	100 000	50 000	1	W 637/8-2ZS	
	16	4	0,715	0,3	0,012	90 000	45 000	3,1	W 618/8-2Z	
	16	5	0,715	0,3	0,012	-	26 000	3,8	W 628/8-2RS1	
	16	5	0,715	0,3	0,012	90 000	45 000	3,8	W 628/8-2Z	
	16	6	0,715	0,3	0,012	90 000	45 000	4,1	W 638/8-2Z	
	19	6	1,25	0,455	0,02	-	24 000	6,5	W 619/8-2RS1	
	19	6	1,25	0,455	0,02	85 000	43 000	6,8	W 619/8-2Z	
	22	7	1,99	0,78	0,034	-	22 000	11,5	W 608-2RS1	
	22	7	1,99	0,78	0,034	75 000	38 000	11,5	W 608-2Z	
24	8	2,47	1,12	0,048	70 000	36 000	17	W 628-2Z		
24	8	2,47	1,12	0,048	-	20 000	17	W 628-2RS1		
28	9	3,97	1,96	0,083	-	19 000	28	W 638-2RS1		
28	9	3,97	1,96	0,083	67 000	32 000	28,5	W 638-2Z		

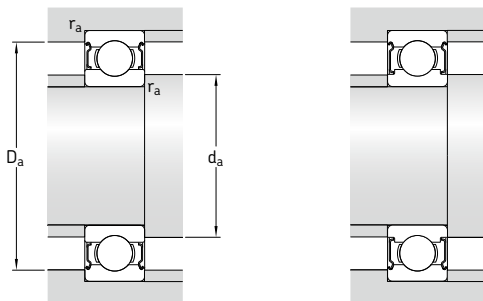

Dimensions

Abutment and fillet dimensions

Calculation factors

d	d ₁	d ₂	D ₂	r _{1,2} min.	d _a min.	d _a max.	D _a max.	r _a max.	k _r	f ₀	
mm	~	~	~		mm				-		
6 cont.	-	7,5	13	0,2	7,3	7,4	14,4	0,2	0,025	6,8	
	-	7,5	13	0,2	7,3	7,4	14,4	0,2	0,025	6,8	
	-	8,2	14,8	0,3	8	8,1	15	0,3	0,03	11	
	-	8,2	14,8	0,3	8	8,1	15	0,3	0,03	11	
	-	8,5	16,5	0,3	8	8,4	17	0,3	0,03	7,9	
	-	8,5	16,5	0,3	8	8,4	17	0,3	0,03	7,9	
	-	10,5	19,1	0,3	8	10,4	20	0,3	0,035	7,2	
	-	10,5	19,1	0,3	8	10,4	20	0,3	0,035	7,2	
	7	8	-	10,3	0,15	7,9	8	10,3	0,15	0,015	8,1
		-	8,5	12,7	0,15	8,2	8,4	12,8	0,15	0,02	7,2
-		8,5	12,7	0,15	8,2	8,4	12,8	0,15	0,02	7,2	
-		9,2	14,3	0,3	9	9,1	15	0,3	0,025	7,3	
-		9,2	14,3	0,3	9	9,1	15	0,3	0,025	7,3	
-		9	16,5	0,3	8,7	8,9	17	0,3	0,03	7,9	
-		9	16,5	0,3	8,7	8,9	17	0,3	0,03	7,9	
-		10,5	19,1	0,3	9	10,4	20	0,3	0,03	7,2	
-		10,5	19,1	0,3	9	10,4	20	0,3	0,03	7,2	
-		13,9	22,4	0,3	9	13,8	24	0,3	0,035	12	
-		13,9	22,4	0,3	9	13,8	24	0,3	0,035	12	
8		9	-	11,4	0,1	8,8	8,9	11,5	0,1	0,02	8,2
	9	-	11,4	0,1	8,8	9	11,5	0,1	0,02	8,2	
	-	9,6	14,2	0,2	9,5	9,6	14,4	0,2	0,02	7,5	
	-	9,6	14,2	0,2	9,5	9,6	14,4	0,2	0,02	7,5	
	-	9,6	14,2	0,2	9,5	9,6	14,4	0,2	0,02	7,5	
	-	9,6	14,2	0,2	9,5	9,6	14,4	0,2	0,02	7,5	
	-	9,6	14,2	0,2	9,5	9,6	14,4	0,2	0,02	7,5	
	-	9,8	16,7	0,3	9,7	9,7	17	0,3	0,025	6,6	
	-	9,8	16,7	0,3	9,7	9,7	17	0,3	0,025	6,6	
	-	10,5	19,1	0,3	10	10,4	20	0,3	0,03	7,2	
	-	10,5	19,1	0,3	10	10,4	20	0,3	0,03	7,2	
	-	11,9	19,9	0,3	10	11,8	22	0,3	0,03	10	
	-	11,9	19,9	0,3	10	11,8	22	0,3	0,03	10	
	-	13,9	22,4	0,3	10	13,8	26	0,3	0,035	12	
	-	13,9	22,4	0,3	10	13,8	26	0,3	0,035	12	

1.7 Capped stainless steel deep groove ball bearings d 9 – 12 mm

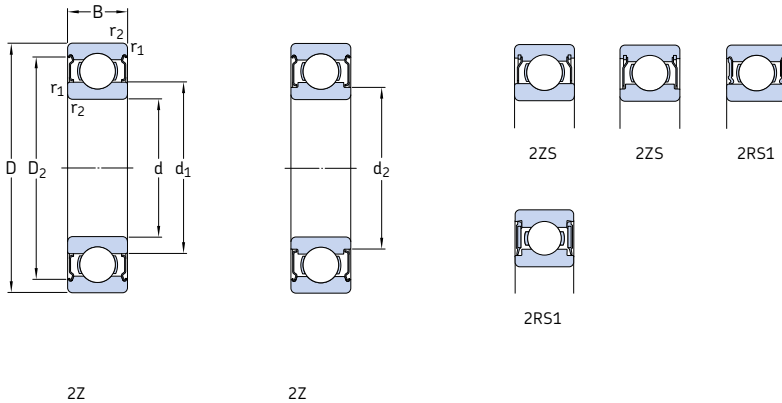

Principal dimensions			Basic load ratings		Fatigue load limit	Speed ratings		Mass	Designation	
d	D	B	dynamic	static		Reference speed	Limiting speed			
mm			C	C ₀	P _u	r/min	g	-		
9	14	4,5	0,52	0,236	0,01	95 000	45 000	1,8	W 637/9-2ZS	
	17	5	0,761	0,335	0,014	-	24 000	4,2	W 628/9-2RS1	
	17	5	0,761	0,335	0,014	85 000	43 000	4,1	W 628/9-2Z	
	17	6	0,761	0,335	0,014	85 000	43 000	4,9	W 638/9-2Z	
	20	6	2,12	1,06	0,045	80 000	40 000	7,7	W 619/9-2Z	
	20	6	2,12	1,06	0,045	-	22 000	7,6	W 619/9-2RS1	
	24	7	2,03	0,815	0,036	-	20 000	14,5	W 609-2RS1	
	24	7	2,03	0,815	0,036	70 000	36 000	14,5	W 609-2Z	
	26	8	3,97	1,96	0,083	-	19 000	19	W 629-2RS1	
	26	8	3,97	1,96	0,083	67 000	32 000	19,5	W 629-2Z	
	30	10	4,94	2,32	0,1	-	16 000	35	W 639-2RS1	
	30	10	4,94	2,32	0,1	60 000	30 000	33,5	W 639-2Z	
	10	15	4	0,488	0,22	0,009	-	24 000	1,8	W 61700 X-2RS1
		15	4	0,488	0,22	0,009	85 000	43 000	1,8	W 61700 X-2Z
19		5	1,48	0,83	0,036	-	22 000	5,2	W 61800-2RS1	
19		5	1,48	0,83	0,036	80 000	38 000	5,1	W 61800-2Z	
19		7	1,48	0,83	0,036	80 000	38 000	7,1	W 63800-2Z	
19		7	1,48	0,83	0,036	-	22 000	7,1	W 63800-2RS1	
22		6	2,7	1,27	0,054	-	20 000	9,4	W 61900-2RS1	
22		6	2,7	1,27	0,054	70 000	36 000	9,5	W 61900-2Z	
26		8	3,97	1,96	0,083	-	19 000	18,5	W 6000-2RS1	
26		8	3,97	1,96	0,083	67 000	32 000	18,5	W 6000-2Z	
30		9	4,36	2,32	0,1	-	16 000	30,5	W 6200-2RS1	
30		9	4,36	2,32	0,1	60 000	30 000	30,5	W 6200-2Z	
35		11	7,02	3,4	0,146	-	15 000	51	W 6300-2RS1	
35		11	7,02	3,4	0,146	53 000	26 000	53	W 6300-2Z	
12	18	4	0,527	0,265	0,011	-	22 000	3	W 61701-2RS1	
	18	4	0,527	0,265	0,011	75 000	38 000	2,9	W 61701-2Z	
	21	5	1,51	0,9	0,039	-	20 000	6	W 61801-2RS1	
	21	5	1,51	0,9	0,039	70 000	36 000	5,8	W 61801-2Z	
	21	7	1,51	0,9	0,039	-	20 000	8,2	W 63801-2RS1	
	21	7	1,51	0,9	0,039	70 000	36 000	7,8	W 63801-2Z	

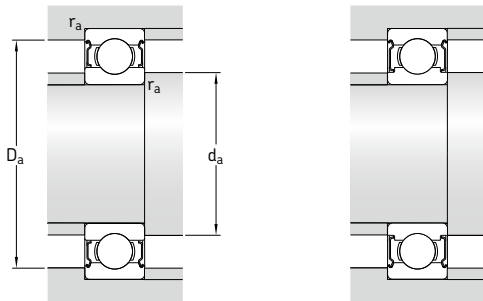

Dimensions

Abutment and fillet dimensions

Calculation factors

d	d ₁	d ₂	D ₂	r _{1,2} min.	d _a min.	d _a max.	D _a max.	r _a max.	k _r	f ₀	
mm	~	~	~		mm				-		
9	-	10,2	13,2	0,1	9,8	10,2	13,3	0,1	0,02	7,8	
	-	10,7	15,2	0,2	10,3	10,6	15,4	0,2	0,02	7,7	
	-	10,7	15,2	0,2	10,3	10,6	15,4	0,2	0,02	7,7	
	-	10,7	15,2	0,2	10,3	10,6	15,4	0,2	0,02	7,7	
	11,6	-	17,5	0,3	11	11,5	18	0,3	0,025	13	
	11,6	-	17,5	0,3	11	11,5	18	0,3	0,025	13	
	-	12,1	20,5	0,3	11	12	22	0,3	0,03	7,5	
	-	12,1	20,5	0,3	11	12	22	0,3	0,03	7,5	
	-	13,9	22,4	0,6	13	13,8	22,6	0,6	0,03	12	
	-	13,9	22,4	0,6	13	13,8	22,6	0,6	0,03	12	
	-	15,3	25,3	0,6	13	15,2	26	0,6	0,035	13	
	-	15,3	25,3	0,6	13	15,2	26	0,6	0,035	13	
	10	11,2	-	14,2	0,15	11	11	14,5	0,15	0,015	8
		11,2	-	14,1	0,15	11	11	14,5	0,15	0,015	8
-		11,8	17,2	0,3	11,5	11,5	17,5	0,3	0,02	15	
-		11,8	17,2	0,3	11,5	11,5	17,5	0,3	0,02	15	
-		11,8	17,2	0,3	11,5	11,5	17,5	0,3	0,02	15	
-		11,8	17,2	0,3	11,5	11,5	17,5	0,3	0,02	15	
-		13,2	19,4	0,3	12	13	20	0,3	0,025	14	
-		13,2	19,4	0,3	12	13	20	0,3	0,025	14	
-		13,9	22,4	0,3	12	13,5	24	0,3	0,03	12	
-		13,9	22,4	0,3	12	13,5	24	0,3	0,03	12	
-		15,3	25,3	0,6	14	15	26	0,6	0,03	13	
-		15,3	25,3	0,6	14	15	26	0,6	0,03	13	
17,7		-	29,3	0,6	14	17,5	31	0,6	0,035	11	
17,7		-	29,3	0,6	14	17,5	31	0,6	0,035	11	
12	13,8	-	16,7	0,2	13,5	13,5	17	0,2	0,015	8,2	
	13,8	-	16,7	0,2	13,5	13,5	17	0,2	0,015	8,2	
	-	13,8	19,2	0,3	13,5	13,5	19,5	0,3	0,02	13	
	-	13,8	19,2	0,3	13,5	13,5	19,5	0,3	0,02	13	
	-	13,8	19,2	0,3	13,5	13,5	19,5	0,3	0,02	13	
	-	13,8	19,2	0,3	13,5	13,5	19,5	0,3	0,02	13	
	-	13,8	19,2	0,3	13,5	13,5	19,5	0,3	0,02	13	

1.7 Capped stainless steel deep groove ball bearings d 12 – 17 mm

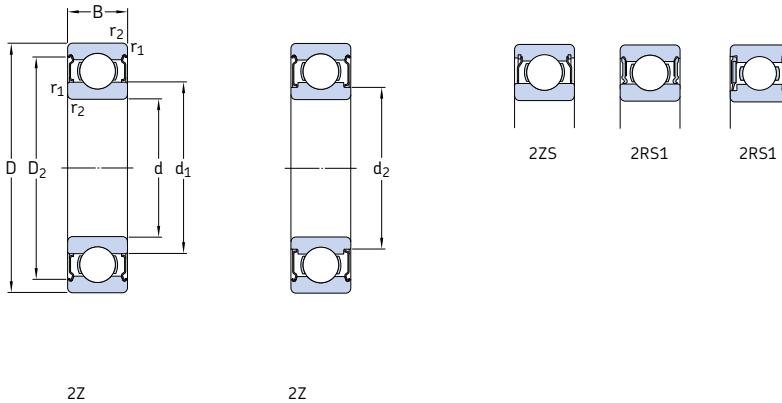

Principal dimensions			Basic load ratings		Fatigue load limit	Speed ratings		Mass	Designation	
d	D	B	dynamic	static		Reference speed	Limiting speed			
mm			C	C ₀	P _u	r/min	g	-		
12 cont.	24	6	2,51	1,46	0,062	-	19 000	11	W 61901-2RS1	
	24	6	2,51	1,46	0,062	67 000	32 000	11,5	W 61901-2Z	
	28	8	4,42	2,36	0,102	-	16 000	20	W 6001-2RS1	
	28	8	4,42	2,36	0,102	60 000	30 000	20	W 6001-2Z	
	32	10	5,72	3	0,127	-	15 000	36	W 6201-2RS1	
	32	10	5,72	3	0,127	53 000	28 000	36	W 6201-2Z	
	37	12	9,75	4,15	0,176	-	14 000	57	W 6301-2RS1	
	37	12	9,75	4,15	0,176	48 000	24 000	60	W 6301-2Z	
	15	21	4	0,618	0,3	0,012	-	19 000	3,6	W 61702-2RS1
		21	4	0,618	0,3	0,012	67 000	32 000	3,6	W 61702-2Z
24		5	1,65	1,08	0,048	-	17 000	7,1	W 61802-2RS1	
24		5	1,65	1,08	0,048	60 000	30 000	6,8	W 61802-2Z	
24		7	1,65	1,08	0,048	-	17 000	9,9	W 63802-2RS1	
24		7	1,65	1,08	0,048	60 000	30 000	9,6	W 63802-2Z	
28		7	3,71	2,24	0,095	-	16 000	16	W 61902-2RS1	
28		7	3,71	2,24	0,095	56 000	28 000	16	W 61902-2Z	
32		9	4,88	2,8	0,12	-	14 000	29	W 6002-2RS1	
32		9	4,88	2,8	0,12	50 000	26 000	29	W 6002-2Z	
35		11	6,37	3,6	0,156	-	13 000	44	W 6202-2RS1	
35		11	6,37	3,6	0,156	48 000	24 000	44	W 6202-2Z	
42		13	9,95	5,4	0,232	-	11 000	79,5	W 6302-2RS1	
42		13	9,95	5,4	0,232	40 000	20 000	82,5	W 6302-2Z	
17	23	4	0,559	0,34	0,015	-	17 000	3,9	W 61703-2RS1	
	23	4	0,559	0,34	0,015	60 000	30 000	3,9	W 61703-2Z	
	26	5	1,78	1,27	0,054	-	16 000	8	W 61803-2RS1	
	26	5	1,78	1,27	0,054	56 000	28 000	7,6	W 61803-2Z	
	26	7	1,78	1,27	0,054	-	16 000	11	W 63803-2RS1	
	26	7	1,78	1,27	0,054	56 000	28 000	10,5	W 63803-2Z	
	30	7	3,97	2,55	0,108	-	14 000	17,5	W 61903-2RS1	
	30	7	3,97	2,55	0,108	50 000	24 000	17	W 61903-2Z	
	35	10	4,94	3,15	0,137	-	13 000	38,5	W 6003-2RS1	
	35	10	4,94	3,15	0,137	45 000	22 000	39	W 6003-2Z	

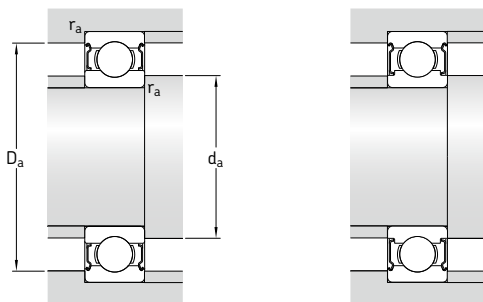

Dimensions

Abutment and fillet dimensions

Calculation factors

d	d ₁	d ₂	D ₂	r _{1,2} min.	d _a min.	d _a max.	D _a max.	r _a max.	k _r	f ₀	
mm	~	~	~		mm				-		
12 cont.	-	15,3	21,4	0,3	14	15	22	0,3	0,025	15	
	-	15,3	21,4	0,3	14	15	22	0,3	0,025	15	
	-	16	25,2	0,3	14	15,5	26	0,3	0,03	13	
	-	16	25,2	0,3	14	15,5	26	0,3	0,03	13	
	18,5	-	28	0,6	16	18	28,5	0,6	0,03	12	
	18,5	-	28	0,6	16	18	28,5	0,6	0,03	12	
	19,3	-	32	1	17	19	32,5	1	0,035	11	
	19,3	-	32	1	17	19	32,5	1	0,035	11	
	15	16,8	-	19,7	0,2	16,5	16,5	20	0,2	0,015	8,4
		16,8	-	19,7	0,2	16,5	16,5	20	0,2	0,015	8,4
-		16,8	22,2	0,3	16,5	16,5	22,5	0,3	0,02	14	
-		16,8	22,2	0,3	16,5	16,5	22,5	0,3	0,02	14	
-		16,8	22,2	0,3	16,5	16,5	22,5	0,3	0,02	14	
-		16,8	22,2	0,3	16,5	16,5	22,5	0,3	0,02	14	
-		16,8	22,2	0,3	16,5	16,5	22,5	0,3	0,02	14	
18,8		-	25,3	0,3	17	18,5	26	0,3	0,025	14	
18,8		-	25,3	0,3	17	18,5	26	0,3	0,025	14	
-		18,6	29,1	0,3	17	18,5	30	0,3	0,03	14	
-		18,6	29,1	0,3	17	18,5	30	0,3	0,03	14	
21,7		-	31,4	0,6	19	21,5	32	0,6	0,03	13	
21,7		-	31,4	0,6	19	21,5	32	0,6	0,03	13	
24,5		-	36,8	1	20	24	37,5	1	0,035	12	
24,5		-	36,8	1	20	24	37,5	1	0,035	12	
17	18,8	-	21,7	0,2	18,5	18,5	22	0,2	0,015	8,5	
	18,8	-	21,7	0,2	18,5	18,5	22	0,2	0,015	8,5	
	-	18,8	24,2	0,3	18,5	18,5	24,5	0,3	0,02	14	
	-	18,8	24,2	0,3	18,5	18,5	24,5	0,3	0,02	14	
	-	18,8	24,2	0,3	18,5	18,5	24,5	0,3	0,02	14	
	-	18,8	24,2	0,3	18,5	18,5	24,5	0,3	0,02	14	
	-	18,8	24,2	0,3	18,5	18,5	24,5	0,3	0,02	14	
	21	-	27,8	0,3	19	20,5	28,5	0,3	0,025	15	
	21	-	27,8	0,3	19	20,5	28,5	0,3	0,025	15	
	23,5	-	31,9	0,3	19	23	33	0,3	0,03	14	
	23,5	-	31,9	0,3	19	23	33	0,3	0,03	14	

1.7 Capped stainless steel deep groove ball bearings d 17 – 25 mm

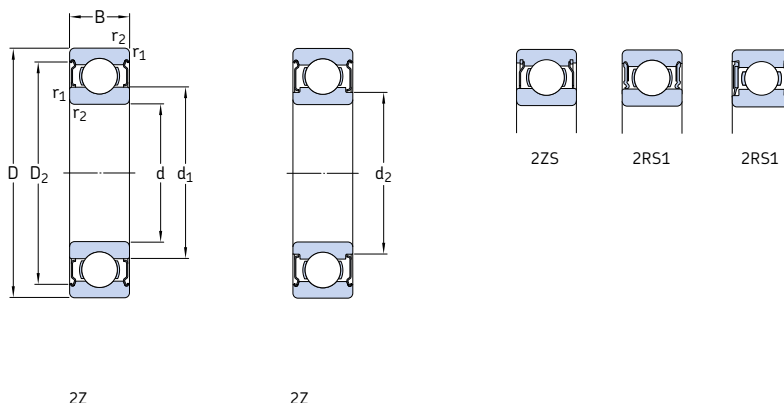

Principal dimensions			Basic load ratings		Fatigue load limit	Speed ratings		Mass	Designation	
d	D	B	dynamic	static		Reference speed	Limiting speed			
mm			C	C ₀	P _u	r/min	g	-		
17 cont.	40	12	8,06	4,75	0,2	-	12 000	64,5	W 6203-2RS1	
	40	12	8,06	4,75	0,2	40 000	20 000	65,5	W 6203-2Z	
	47	14	11,7	6,55	0,28	-	10 000	113	W 6303-2RS1	
	47	14	11,7	6,55	0,28	36 000	18 000	113	W 6303-2Z	
20	27	4	0,585	0,39	0,017	50 000	26 000	5,7	W 61704-2ZS	
	27	4	0,585	0,39	0,017	-	14 000	5,9	W 61704-2RS1	
	32	7	3,12	2,08	0,09	-	13 000	18	W 61804-2RS1	
	32	7	3,12	2,08	0,09	48 000	24 000	17,5	W 61804-2Z	
	32	10	3,12	2,08	0,09	-	13 000	24,5	W 63804-2RS1	
	32	10	3,12	2,08	0,09	48 000	24 000	24,5	W 63804-2Z	
	37	9	5,53	3,65	0,156	-	12 000	35,5	W 61904-2RS1	
	37	9	5,53	3,65	0,156	43 000	20 000	35,5	W 61904-2Z	
	42	12	9,36	5,1	0,212	-	11 000	65,5	W 6004-2RS1	
	42	12	9,36	5,1	0,212	38 000	19 000	65	W 6004-2Z	
	47	14	12,5	6,55	0,28	-	10 000	105	W 6204-2RS1	
	47	14	12,5	6,55	0,28	34 000	17 000	106	W 6204-2Z	
	52	15	13,8	7,8	0,335	-	9 500	146	W 6304-2RS1	
	52	15	13,8	7,8	0,335	34 000	17 000	146	W 6304-2Z	
	25	32	4	0,618	0,465	0,02	-	12 000	7,3	W 61705-2RS1
		37	7	3,9	2,55	0,108	-	11 000	21,5	W 61805-2RS1
37		7	3,9	2,55	0,108	38 000	19 000	21	W 61805-2Z	
37		10	3,9	2,55	0,108	-	11 000	29,5	W 63805-2RS1	
37		10	3,9	2,55	0,108	38 000	19 000	29,5	W 63805-2Z	
42		9	6,05	4,5	0,193	-	10 000	42	W 61905-2RS1	
42		9	6,05	4,5	0,193	34 000	17 000	42,5	W 61905-2Z	
47		12	10,1	5,85	0,25	-	9 500	77	W 6005-2RS1	
47		12	10,1	5,85	0,25	32 000	16 000	78	W 6005-2Z	
52		15	11,7	7,65	0,335	-	8 500	130	W 6205-2RS1	
52		15	11,7	7,65	0,335	30 000	15 000	130	W 6205-2Z	
62		17	20,8	11,2	0,48	-	7 500	235	W 6305-2RS1	
62	17	20,8	11,2	0,48	26 000	13 000	236	W 6305-2Z		

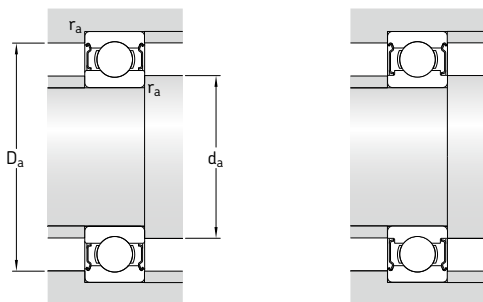

Dimensions

Abutment and fillet dimensions

Calculation factors

d	d ₁ ~	d ₂ ~	D ₂ ~	r _{1,2} min.	d _a min.	d _a max.	D _a max.	r _a max.	k _r	f ₀	
mm	mm								-		
17 cont.	24,9	-	35,8	0,6	21	24,5	37,5	0,6	0,03	13	
	24,9	-	35,8	0,6	21	24,5	37,5	0,6	0,03	13	
	27,5	-	41,1	1	22	27	42	1	0,035	12	
	27,5	-	41,1	1	22	27	42	1	0,035	12	
20	22,3	-	25,3	0,2	21,5	22	26	0,2	0,015	8,7	
	22,3	-	25,5	0,2	21,5	22	26	0,2	0,015	8,7	
	-	22,6	29,6	0,3	22	22,5	30,5	0,3	0,02	13	
	-	22,6	29,6	0,3	22	22,5	30,5	0,3	0,02	13	
	-	22,6	29,6	0,3	22	22,5	30,5	0,3	0,02	13	
	-	22,6	29,6	0,3	22	22,5	30,5	0,3	0,02	13	
	-	23,6	33,5	0,3	22	23,5	35	0,3	0,025	15	
	-	23,6	33,5	0,3	22	23,5	35	0,3	0,025	15	
	27,6	-	38,8	0,6	24	27,5	39,5	0,6	0,03	14	
	27,6	-	38,8	0,6	24	27,5	39,5	0,6	0,03	14	
	29,5	-	41	1	25	29	42	1	0,03	13	
	29,5	-	41	1	25	29	42	1	0,03	13	
	30	-	45,4	1,1	26,5	29,5	46	1	0,035	12	
	30	-	45,4	1,1	26,5	29,5	46	1	0,035	12	
	25	27,3	-	30,3	0,2	26,5	27	31	0,2	0,015	8,8
		28,2	-	34,2	0,3	27	28	35	0,3	0,02	14
28,2		-	34,2	0,3	27	28	35	0,3	0,02	14	
28,2		-	34,2	0,3	27	28	35	0,3	0,02	14	
28,2		-	34,2	0,3	27	28	35	0,3	0,02	14	
28,2		-	34,2	0,3	27	28	35	0,3	0,02	14	
30,9		-	39,5	0,3	27	30,5	40,5	0,3	0,025	15	
30,9		-	39,5	0,3	27	30,5	40,5	0,3	0,025	15	
31,7		-	42,8	0,6	29	31,5	44,5	0,6	0,03	15	
31,7		-	42,8	0,6	29	31,5	44,5	0,6	0,03	15	
34		-	45,8	1	30	33,5	47	1	0,03	14	
34		-	45,8	1	30	33,5	47	1	0,03	14	
38,1		-	53,3	1,1	31,5	38	55,5	1	0,035	13	
38,1		-	53,3	1,1	31,5	38	55,5	1	0,035	13	

1.7 Capped stainless steel deep groove ball bearings d 30 – 40 mm

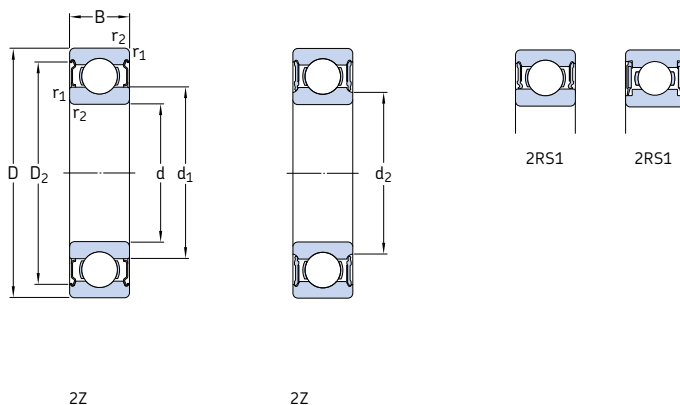

Principal dimensions			Basic load ratings		Fatigue load limit	Speed ratings		Mass	Designation
d	D	B	dynamic	static		Reference speed	Limiting speed		
mm			C	C ₀	P _u	r/min	g	-	
30	42	7	3,58	2,9	0,125	-	9 500	24,5	W 61806-2RS1
	42	7	3,58	2,9	0,125	34 000	17 000	24	W 61806-2Z
	42	10	3,58	2,9	0,125	-	9 500	36	W 63806-2RS1
	42	10	3,58	2,9	0,125	34 000	17 000	36	W 63806-2Z
	47	9	6,24	5	0,212	-	8 500	47,5	W 61906-2RS1
	47	9	6,24	5	0,212	30 000	15 000	48,5	W 61906-2Z
	55	13	13,3	8,3	0,355	-	8 000	113	W 6006-2RS1
	55	13	13,3	8,3	0,355	28 000	14 000	115	W 6006-2Z
	62	16	19	11,4	0,48	-	7 000	196	W 6206-2RS1
	62	16	19	11,4	0,48	26 000	13 000	196	W 6206-2Z
	72	19	22,9	15	0,64	-	6 300	352	W 6306-2RS1
	72	19	22,9	15	0,64	22 000	11 000	350	W 6306-2Z
35	44	5	1,06	0,915	0,039	-	8 500	15,5	W 61707-2RS1
	47	7	3,71	3,35	0,14	-	8 500	29	W 61807-2RS1
	47	7	3,71	3,35	0,14	30 000	15 000	28	W 61807-2Z
	55	10	9,36	7,65	0,325	-	7 500	74,5	W 61907-2RS1
	55	10	9,36	7,65	0,325	26 000	13 000	74	W 61907-2Z
	62	14	13,8	10,2	0,44	-	6 700	148	W 6007-2RS1
	62	14	13,8	10,2	0,44	24 000	12 000	149	W 6007-2Z
	72	17	22,1	15,3	0,655	-	6 000	280	W 6207-2RS1
	72	17	22,1	15,3	0,655	22 000	11 000	279	W 6207-2Z
	80	21	28,6	19	0,815	-	5 600	459	W 6307-2RS1
	80	21	28,6	19	0,815	20 000	10 000	457	W 6307-2Z
	40	50	6	1,43	1,27	0,054	-	7 500	23,5
52		7	4,49	3,75	0,16	-	7 500	32	W 61808-2RS1
52		7	4,49	3,75	0,16	26 000	13 000	31	W 61808-2Z
62		12	11,9	9,8	0,425	-	6 700	111	W 61908-2RS1
62		12	11,9	9,8	0,425	24 000	12 000	112	W 61908-2Z
68		15	14,6	11,4	0,49	-	6 300	186	W 6008-2RS1
68		15	14,6	11,4	0,49	22 000	11 000	186	W 6008-2Z
80		18	25,1	17,6	0,75	-	5 600	358	W 6208-2RS1
80		18	25,1	17,6	0,75	20 000	10 000	357	W 6208-2Z

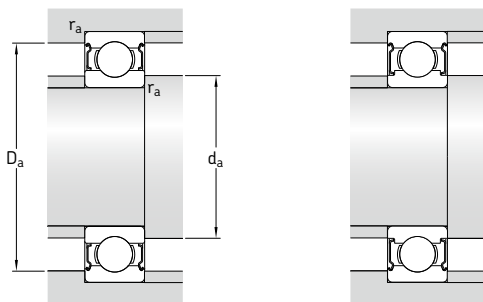

Dimensions

Abutment and fillet dimensions

Calculation factors

d	d ₁ ~	d ₂ ~	D ₂ ~	r _{1,2} min.	d _a min.	d _a max.	D _a max.	r _a max.	k _r	f ₀
mm					mm				-	
30	33,1	-	39,2	0,3	32	33	40	0,3	0,02	14
	33,1	-	39,2	0,3	32	33	40	0,3	0,02	14
	33,1	-	39,2	0,3	32	33	40	0,3	0,02	14
	33,1	-	39,2	0,3	32	33	40	0,3	0,02	14
	35,1	-	44,1	0,3	32	35	45	0,3	0,025	16
	35,1	-	44,1	0,3	32	35	45	0,3	0,025	16
	38	-	50	1	35	37,5	50,5	1	0,03	15
	38	-	50	1	35	37,5	50,5	1	0,03	15
	40,7	-	55,2	1	35	40,5	57	1	0,03	14
	40,7	-	55,2	1	35	40,5	57	1	0,03	14
	44,9	-	62,4	1,1	36,5	44,5	65,5	1	0,035	13
	44,9	-	62,4	1,1	36,5	44,5	65,5	1	0,035	13
35	38	-	42,2	0,3	37	37,5	42,5	0,3	0,015	8,9
	38,2	-	43,7	0,3	37	38	45	0,3	0,02	14
	38,2	-	43,7	0,3	37	38	45	0,3	0,02	14
	42,2	-	52,2	0,6	39	42	52,5	0,6	0,025	16
	42,2	-	52,2	0,6	39	42	52,5	0,6	0,025	16
	44	-	57,1	1	40	43,5	57,5	1	0,03	15
	44	-	57,1	1	40	43,5	57,5	1	0,03	15
	47,6	-	64,9	1,1	41,5	47,5	65,5	1	0,03	14
	47,6	-	64,9	1,1	41,5	47,5	65,5	1	0,03	14
	-	46,7	71,6	1,5	43	46,5	73,5	1,5	0,035	13
	-	46,7	71,6	1,5	43	46,5	73,5	1,5	0,035	13
	40	43,3	-	47,9	0,3	42	43	48,5	0,3	0,015
43,2		-	49	0,3	42	43	50	0,3	0,02	15
43,2		-	49	0,3	42	43	50	0,3	0,02	15
46,9		-	57,6	0,6	44	46,5	59,5	0,6	0,025	16
46,9		-	57,6	0,6	44	46,5	59,5	0,6	0,025	16
49,2		-	62,5	1	45	49	63,5	1	0,03	15
49,2		-	62,5	1	45	49	63,5	1	0,03	15
-		50,1	70,8	1,1	46,5	50	73,5	1	0,03	14
-		50,1	70,8	1,1	46,5	50	73,5	1	0,03	14

1.7 Capped stainless steel deep groove ball bearings d 45 – 50 mm

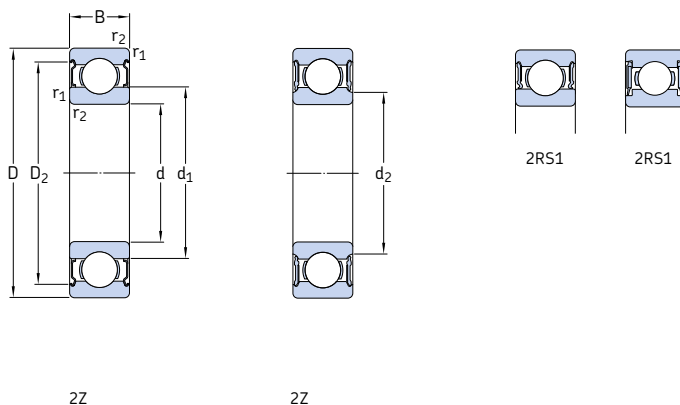

Principal dimensions			Basic load ratings		Fatigue load limit	Speed ratings		Mass	Designation
d	D	B	dynamic	static		Reference speed	Limiting speed		
mm			kN	C ₀	P _u	r/min	g	-	
45	55	6	1,46	1,37	0,06	-	6 700	26	W 61709-2RS1
	58	7	5,72	5	0,212	-	6 700	37,5	W 61809-2RS1
	58	7	5,72	5	0,212	24 000	12 000	36,5	W 61809-2Z
	68	12	14	10,8	0,465	-	6 000	125	W 61909-2RS1
	68	12	14	10,8	0,465	20 000	10 000	125	W 61909-2Z
	75	16	18,2	15	0,64	-	5 600	239	W 6009-2RS1
	75	16	18,2	15	0,64	20 000	10 000	238	W 6009-2Z
	85	19	28,1	20,4	0,865	-	5 000	394	W 6209-2RS1
	85	19	28,1	20,4	0,865	18 000	9 000	392	W 6209-2Z
	50	62	6	1,53	1,53	0,067	-	6 000	37,5
65		7	5,07	5,5	0,236	-	6 000	50,5	W 61810-2RS1
65		7	5,07	5,5	0,236	20 000	10 000	50	W 61810-2Z
72		12	12,5	11,6	0,5	-	5 600	139	W 61910-2RS1
72		12	12,5	11,6	0,5	19 000	9 500	140	W 61910-2Z
80		16	19	16,6	0,71	-	5 000	258	W 6010-2RS1
80		16	19	16,6	0,71	18 000	9 000	258	W 6010-2Z
90		20	30,2	23,2	0,98	-	4 800	444	W 6210-2RS1
90		20	30,2	23,2	0,98	17 000	8 500	448	W 6210-2Z

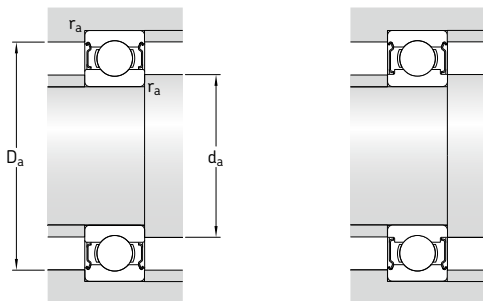

Dimensions

Abutment and fillet dimensions

Calculation factors

d	d ₁ ~	d ₂ ~	D ₂ ~	r _{1,2} min.	d _a min.	d _a max.	D _a max.	r _a max.	k _r	f ₀
mm					mm				-	
45	48,3	-	53,2	0,3	47	48	53,5	0,3	0,015	9,1
	48,2	-	54,9	0,3	47	48	56	0,3	0,02	15
	48,2	-	54,9	0,3	47	48	56	0,3	0,02	15
	52,4	-	63,2	0,6	49	52	64	0,6	0,025	16
	52,4	-	63,2	0,6	49	52	64	0,6	0,025	16
	54,5	-	69	1	50	54	70	1	0,03	15
	54,5	-	69	1	50	54	70	1	0,03	15
	-	53,5	76,4	1,1	51,5	53,5	78,5	1	0,03	14
	-	53,5	76,4	1,1	51,5	53,5	78,5	1	0,03	14
	50	54,3	-	59,2	0,3	52	54	60	0,3	0,015
54,6		-	61,6	0,3	52	54,5	63	0,3	0,02	15
54,6		-	61,6	0,3	52	54,5	63	0,3	0,02	15
56,8		-	67,9	0,6	54	56,5	68,5	0,6	0,025	16
56,8		-	67,9	0,6	54	56,5	68,5	0,6	0,025	16
60		-	74,6	1	55	59,5	75,5	1	0,03	16
60		-	74,6	1	55	59,5	75,5	1	0,03	16
-		60	82,2	1,1	56,5	60	83,5	1	0,03	14
-		60	82,2	1,1	56,5	60	83,5	1	0,03	14

1.8 Single row deep groove ball bearings with filling slots d 25 – 85 mm

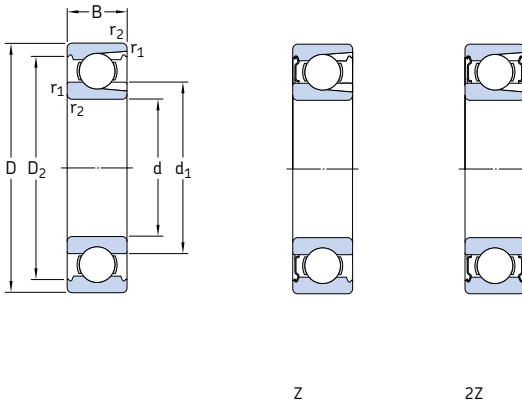

Principal dimensions			Basic load ratings		Fatigue load limit	Speed ratings		Mass	Designations			
d	D	B	dynamic	static		Reference speed	Limiting speed ¹⁾		Bearing open	with a shield on one side	both sides	
mm			C	C ₀	P _u	r/min		kg	-			
25	62	17	22,9	15,6	0,67	20 000	13 000	0,24	305	305-Z	305-2Z	
30	62	16	20,9	16,3	0,695	20 000	12 000	0,21	206	206-Z	206-2Z	
	72	19	29,7	21,6	0,93	18 000	11 000	0,37	306	306-Z	306-2Z	
35	72	17	27,5	22	0,93	17 000	10 000	0,31	207	207-Z	207-2Z	
	80	21	34,7	26,5	1,12	16 000	9 500	0,48	307	307-Z	307-2Z	
40	80	18	33,6	27	1,16	15 000	9 500	0,39	208	208-Z	208-2Z	
	90	23	45,7	36	1,53	14 000	8 500	0,64	308	308-Z	308-2Z	
45	85	19	35,2	30	1,27	14 000	8 500	0,44	209	209-Z	209-2Z	
	100	25	55	44	1,86	13 000	7 500	0,88	309	309-Z	309-2Z	
50	90	20	39,1	34,5	1,46	13 000	8 000	0,5	210	210-Z	210-2Z	
	110	27	64,4	52	2,2	11 000	7 000	1,15	310	310-Z	310-2Z	
55	100	21	48,4	44	1,86	12 000	7 000	0,66	211	211-Z	211-2Z	
	120	29	79,2	67	2,85	10 000	6 300	1,5	311	311-Z	311-2Z	
60	110	22	56,1	50	2,12	11 000	6 700	0,85	212	212-Z	212-2Z	
	130	31	91,3	78	3,35	9 500	6 000	1,85	312	312-Z	312-2Z	
65	120	23	60,5	58,5	2,5	10 000	6 000	1,05	213	213-Z	213-2Z	
	140	33	102	90	3,75	9 000	5 300	2,3	313	313-Z	313-2Z	
70	125	24	66	65,5	2,75	9 500	5 600	1,15	214	214-Z	214-2Z	
	150	35	114	102	4,15	8 000	5 000	2,75	314	314-Z	314-2Z	
75	130	25	72,1	72	3	9 000	5 300	1,25	215	215-Z	215-2Z	
	160	37	125	116	4,55	7 500	4 800	3,25	315	315-Z	315-2Z	
80	140	26	88	85	3,45	8 500	5 000	1,55	216	216-Z	216-2Z	
	170	39	138	129	4,9	7 000	4 300	3,95	316	316-Z	316-2Z	
85	150	28	96,8	100	3,9	7 500	4 800	1,95	217	217-Z	217-2Z	
	180	41	147	146	5,3	6 700	4 000	4,6	317	317-Z	317-2Z	

¹⁾ For bearings with a shield on both sides (2Z), limiting speeds are about 80% of the quoted value.

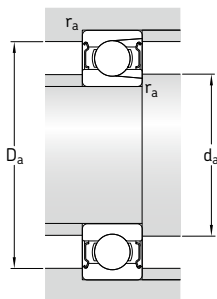

Dimensions				Abutment and fillet dimensions				Minimum load factor
d	d_1	D_2	$r_{1,2}$	d_a	$d_a^{1)}$	D_a	r_a	k_f
mm	~	~	min.	mm	max.	max.	max.	-
25	36,6	52,7	1,1	32	32,7	55	1	0,05
30	40,3	54,1	1	35,6	40,2	56,4	1	0,04
	44,6	61,9	1,1	37	44,5	65	1	0,05
35	46,9	62,7	1,1	42	46,8	65	1	0,04
	49,5	69,2	1,5	44	49,4	71	1,5	0,05
40	52,6	69,8	1,1	47	52,5	73	1	0,04
	56,1	77,7	1,5	49	56	81	1,5	0,05
45	57,6	75,2	1,1	52	57,5	78	1	0,04
	62,1	86,7	1,5	54	62	91	1,5	0,05
50	62,5	81,7	1,1	57	62,4	83	1	0,04
	68,7	95,2	2	61	68,6	99	2	0,05
55	69	89,4	1,5	64	68,9	91	1,5	0,04
	75,3	104	2	66	75,2	109	2	0,05
60	75,5	98	1,5	69	75,4	101	1,5	0,04
	81,8	113	2,1	72	81,7	118	2	0,05
65	83,3	106	1,5	74	83,2	111	1,5	0,04
	88,3	122	2,1	77	88,2	128	2	0,05
70	87	111	1,5	79	87	116	1,5	0,04
	93,7	130	2,1	82	93,7	138	2	0,05
75	92	117	1,5	84	92	121	1,5	0,04
	99,7	139	2,1	87	99,6	148	2	0,05
80	95,8	127	2	88,8	88,8	129	2	0,04
	106	147	2,1	92	105	158	2	0,05
85	104	135	2	96	96,9	139	2	0,04
	112	156	3	98	112	167	2,5	0,05

¹⁾ Only applicable for shielded bearings.

1.8 Single row deep groove ball bearings with filling slots

d 90 – 100 mm

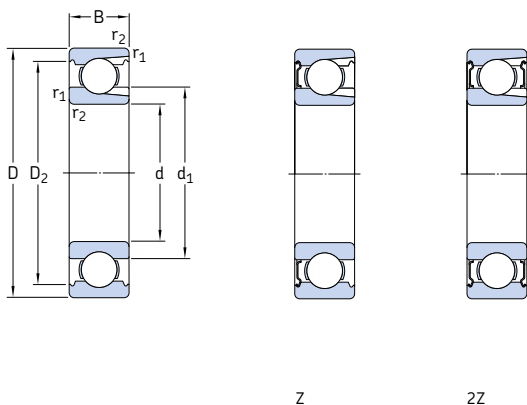

Principal dimensions			Basic load ratings		Fatigue load limit	Speed ratings		Mass	Designations		
d	D	B	dynamic	static		Reference speed	Limiting speed ¹⁾		Bearing open	with a shield on one side	both sides
mm			kN		kN	r/min		kg	-		
90	160	30	112	114	4,3	7 000	4 300	2,35	218	218-Z	218-2Z
	190	43	157	160	5,7	6 300	4 000	5,4	318	318-Z	318-2Z
95	170	32	121	122	4,5	6 700	4 000	2,7	219	219-Z	219-2Z
100	180	34	134	140	5	6 300	4 000	3,45	220	220-Z	220-2Z

¹⁾ For bearings with a shield on both sides (2Z), limiting speeds are about 80% of the quoted value.

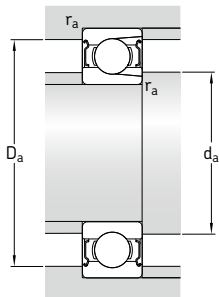

Dimensions				Abutment and fillet dimensions				Minimum load factor
d	d ₁ ~	D ₂ ~	r _{1,2} min.	d _a min.	d _a ¹⁾ max.	D _a max.	r _a max.	k _r
mm				mm				-
90	110	143	2	100	110	150	2	0,04
	119	164	3	103	118	177	2,5	0,05
95	116	152	2,1	107	116	158	2	0,04
100	123	160	2,1	112	122	168	2	0,04

¹⁾ Only applicable for shielded bearings.

1.9 Single row deep groove ball bearings with filling slots and a snap ring d 25 – 95 mm

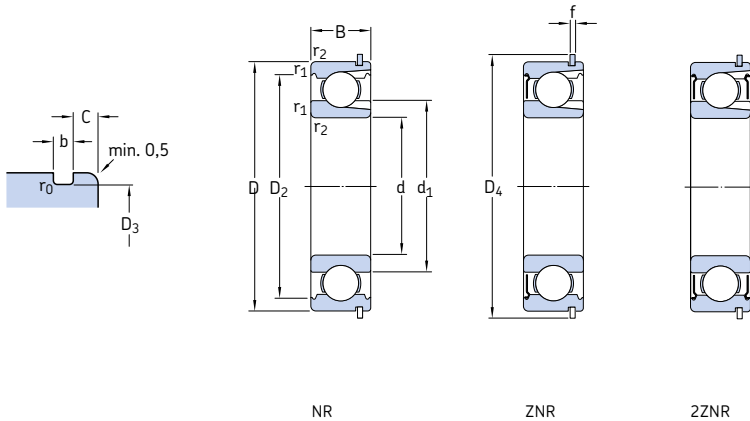

Principal dimensions			Basic load ratings dynamic static		Fatigue load limit P_u	Speed ratings Reference speed Limiting speed ¹⁾		Mass	Designations Bearing open with a shield on one side both sides			Snap ring
d	D	B	C	C_0				kg				
mm			kN		kN	r/min			-			
25	62	17	22,9	15,6	0,67	20 000	13 000	0,24	305 NR	305-ZNR	305-2ZNR	SP 62
30	62	16	20,9	16,3	0,695	20 000	12 000	0,21	206 NR	206-ZNR	206-2ZNR	SP 62
	72	19	29,7	21,6	0,93	18 000	11 000	0,37	306 NR	306-ZNR	306-2ZNR	SP 72
35	72	17	27,5	22	0,93	17 000	10 000	0,31	207 NR	207-ZNR	207-2ZNR	SP 72
	80	21	34,7	26,5	1,12	16 000	9 500	0,48	307 NR	307-ZNR	307-2ZNR	SP 80
40	80	18	33,6	27	1,16	15 000	9 500	0,39	208 NR	208-ZNR	208-2ZNR	SP 80
	90	23	45,7	36	1,53	14 000	8 500	0,64	308 NR	308-ZNR	308-2ZNR	SP 90
45	85	19	35,2	30	1,27	14 000	8 500	0,44	209 NR	209-ZNR	209-2ZNR	SP 85
	100	25	55	44	1,86	13 000	7 500	0,88	309 NR	309-ZNR	309-2ZNR	SP 100
50	90	20	39,1	34,5	1,46	13 000	8 000	0,5	210 NR	210-ZNR	210-2ZNR	SP 90
	110	27	64,4	52	2,2	11 000	7 000	1,15	310 NR	310-ZNR	310-2ZNR	SP 110
55	100	21	48,4	44	1,86	12 000	7 000	0,66	211 NR	211-ZNR	211-2ZNR	SP 100
	120	29	79,2	67	2,85	10 000	6 300	1,5	311 NR	311-ZNR	311-2ZNR	SP 120
60	110	22	56,1	50	2,12	11 000	6 700	0,85	212 NR	212-ZNR	212-2ZNR	SP 110
	130	31	91,3	78	3,35	9 500	6 000	1,85	312 NR	312-ZNR	312-2ZNR	SP 130
65	120	23	60,5	58,5	2,5	10 000	6 000	1,05	213 NR	213-ZNR	213-2ZNR	SP 120
	140	33	102	90	3,75	9 000	5 300	2,3	313 NR	313-ZNR	313-2ZNR	SP 140
70	125	24	66	65,5	2,75	9 500	5 600	1,15	214 NR	214-ZNR	214-2ZNR	SP 125
	150	35	114	102	4,15	8 000	5 000	2,75	314 NR	314-ZNR	314-2ZNR	SP 150
75	130	25	72,1	72	3	9 000	5 300	1,25	215 NR	215-ZNR	215-2ZNR	SP 130
80	140	26	88	85	3,45	8 500	5 000	1,55	216 NR	216-ZNR	216-2ZNR	SP 140
85	150	28	96,8	100	3,9	7 500	4 800	1,95	217 NR	-	-	SP 150
90	160	30	112	114	4,3	7 000	4 300	2,35	218 NR	-	-	SP 160
95	170	32	121	122	4,5	6 700	4 000	2,7	219 NR	-	-	SP 170

¹⁾ For bearings with a shield on both sides (2Z), limiting speeds are about 80% of the quoted value.

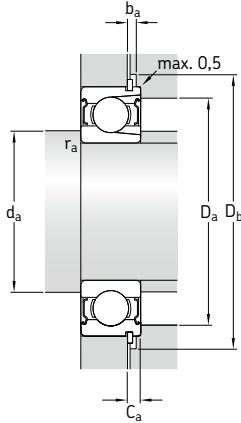

Dimensions										Abutment and fillet dimensions							Minimum load factor
d	d ₁	D ₂	D ₃	D ₄	b	f	C	r ₀	r _{1,2}	d _a	d _a ¹⁾	D _a	D _b	b _a	C _a	r _a	k _r
mm										mm							-
25	36,6	52,7	59,61	67,7	1,9	1,7	3,28	0,6	1,1	32	32,7	55	69	2,2	4,98	1	0,05
30	40,3	54,1	59,61	67,7	1,9	1,7	3,28	0,6	1	35,6	40,2	56,4	69	2,2	4,98	1	0,04
	44,6	61,9	68,81	78,6	1,9	1,7	3,28	0,6	1,1	37	44,5	65	80	2,2	4,98	1	0,05
35	46,9	62,7	68,81	78,6	1,9	1,7	3,28	0,6	1,1	42	46,8	65	80	2,2	4,98	1	0,04
	49,5	69,2	76,81	86,6	1,9	1,7	3,28	0,6	1,5	44	49,4	71	88	2,2	4,98	1,5	0,05
40	52,6	69,8	76,81	86,6	1,9	1,7	3,28	0,6	1,1	47	52,5	73	88	2,2	4,98	1	0,04
	56,1	77,7	86,79	96,5	2,7	2,46	3,28	0,6	1,5	49	56	81	98	3	5,74	1,5	0,05
45	57,6	75,2	81,81	91,6	1,9	1,7	3,28	0,6	1,1	52	57,5	78	93	2,2	4,98	1	0,04
	62,1	86,7	96,8	106,5	2,7	2,46	3,28	0,6	1,5	54	62	91	108	3	5,74	1,5	0,05
50	62,5	81,7	86,79	96,5	2,7	2,46	3,28	0,6	1,1	57	62,4	83	98	3	5,74	1	0,04
	68,7	95,2	106,81	116,6	2,7	2,46	3,28	0,6	2	61	68,6	99	118	3	5,74	2	0,05
55	69	89,4	96,8	106,5	2,7	2,46	3,28	0,6	1,5	64	68,9	91	108	3	5,74	1,5	0,04
	75,3	104	115,21	129,7	3,1	2,82	4,06	0,6	2	66	75,2	109	131	3,5	6,88	2	0,05
60	75,5	98	106,81	116,6	2,7	2,46	3,28	0,6	1,5	69	75,4	101	118	3	5,74	1,5	0,04
	81,8	113	125,22	139,7	3,1	2,82	4,06	0,6	2,1	72	81,7	118	141	3,5	6,88	2	0,05
65	83,3	106	115,21	129,7	3,1	2,82	4,06	0,6	1,5	74	83,2	111	131	3,5	6,88	1,5	0,04
	88,3	122	135,23	149,7	3,1	2,82	4,9	0,6	2,1	77	88,2	128	151	3,5	7,72	2	0,05
70	87	111	120,22	134,7	3,1	2,82	4,06	0,6	1,5	79	87	116	136	3,5	6,88	1,5	0,04
	93,7	130	145,24	159,7	3,1	2,82	4,9	0,6	2,1	82	93,7	138	162	3,5	7,72	2	0,05
75	92	117	125,22	139,7	3,1	2,82	4,06	0,6	1,5	84	92	121	141	3,5	6,88	1,5	0,04
80	95,8	127	135,23	149,7	3,1	2,82	4,9	0,6	2	88,8	88,8	129	151	3,5	7,72	2	0,04
85	104	135	145,24	159,7	3,1	2,82	4,9	0,6	2	96	-	139	162	3,5	7,72	2	0,04
90	110	143	155,22	169,7	3,1	2,82	4,9	0,6	2	100	-	150	172	3,5	7,72	2	0,04
95	116	152	163,65	182,9	3,5	3,1	5,69	0,6	2,1	107	-	158	185	4	8,79	2	0,04

¹⁾ Only applicable for shielded bearings.

1.10 Double row deep groove ball bearings

d 10 – 65 mm

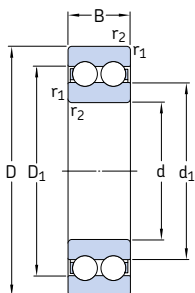

Principal dimensions			Basic load ratings		Fatigue load limit P_u	Speed ratings		Mass kg	Designation
d	D	B	dynamic C	static C_0		Reference speed	Limiting speed		
mm			kN		kN	r/min		kg	–
10	30	14	9,23	5,2	0,224	40 000	22 000	0,049	4200 ATN9
12	32	14	10,6	6,2	0,26	36 000	20 000	0,052	4201 ATN9
	37	17	13	7,8	0,325	34 000	18 000	0,092	4301 ATN9
15	35	14	11,9	7,5	0,32	32 000	17 000	0,059	4202 ATN9
	42	17	14,8	9,5	0,405	28 000	15 000	0,12	4302 ATN9
17	40	16	14,8	9,5	0,405	28 000	15 000	0,09	4203 ATN9
	47	19	19,5	13,2	0,56	24 000	13 000	0,16	4303 ATN9
20	47	18	17,8	12,5	0,53	24 000	13 000	0,14	4204 ATN9
	52	21	23,4	16	0,68	22 000	12 000	0,21	4304 ATN9
25	52	18	19	14,6	0,62	20 000	11 000	0,17	4205 ATN9
	62	24	31,9	22,4	0,95	18 000	10 000	0,34	4305 ATN9
30	62	20	26	20,8	0,88	17 000	9 500	0,29	4206 ATN9
	72	27	41	30	1,27	16 000	8 500	0,5	4306 ATN9
35	72	23	35,1	28,5	1,2	15 000	8 000	0,4	4207 ATN9
	80	31	50,7	38	1,63	14 000	7 500	0,68	4307 ATN9
40	80	23	37,1	32,5	1,37	13 000	7 000	0,5	4208 ATN9
	90	33	55,9	45	1,9	12 000	6 700	0,95	4308 ATN9
45	85	23	39	36	1,53	12 000	6 700	0,54	4209 ATN9
	100	36	68,9	56	2,4	11 000	6 000	1,25	4309 ATN9
50	90	23	41	40	1,7	11 000	6 000	0,58	4210 ATN9
	110	40	81,9	69,5	2,9	10 000	5 300	1,7	4310 ATN9
55	100	25	44,9	44	1,9	10 000	5 600	0,8	4211 ATN9
	120	43	97,5	83	3,45	9 000	5 000	2,15	4311 ATN9
60	110	28	57,2	55	2,36	9 500	5 300	1,1	4212 ATN9
	130	46	112	98	4,15	8 500	4 500	2,65	4312 ATN9
65	120	31	67,6	67	2,8	8 500	4 800	1,45	4213 ATN9
	140	48	121	106	4,5	8 000	4 300	3,25	4313 ATN9

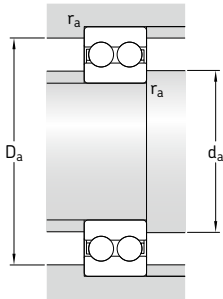

Dimensions				Abutment and fillet dimensions			Calculation factor	
d	d_1 ~	D_1 ~	$r_{1,2}$ min.	d_a min.	D_a max.	r_a max.	k_r	f_0
mm				mm			-	
10	16,7	23,3	0,6	14,2	25,8	0,6	0,05	12
12	18,3 20,5	25,7 28,5	0,6 1	16,2 17,6	27,8 31,4	0,6 1	0,05 0,06	12 12
15	21,5 24,5	29 32,5	0,6 1	19,2 20,6	30,8 36,4	0,6 1	0,05 0,06	13 13
17	24,3 28,7	32,7 38,3	0,6 1	21,2 22,6	35,8 41,4	0,6 1	0,05 0,06	13 13
20	29,7 31,8	38,3 42,2	1 1,1	25,6 27	41,4 45	1 1	0,05 0,06	14 13
25	34,2 37,3	42,8 49,7	1 1,1	30,6 32	46,4 55	1 1	0,05 0,06	14 13
30	40,9 43,9	51,1 58,1	1 1,1	35,6 37	56,4 65	1 1	0,05 0,06	14 13
35	47,5 49,5	59,5 65,4	1,1 1,5	42 44	65 71	1 1,5	0,05 0,06	14 13
40	54 56,9	66 73,1	1,1 1,5	47 49	73 81	1 1,5	0,05 0,06	15 14
45	59,5 63,5	71,5 81,5	1,1 1,5	52 54	78 91	1 1,5	0,05 0,06	15 14
50	65,5 70	77,5 90	1,1 2	57 61	83 99	1 2	0,05 0,06	15 14
55	71,2 76,5	83,8 98,5	1,5 2	64 66	91 109	1,5 2	0,05 0,06	16 14
60	75,6 83,1	90,4 107	1,5 2,1	69 72	101 118	1,5 2	0,05 0,06	15 14
65	82,9 89,6	99,1 115	1,5 2,1	74 77	111 128	1,5 2	0,05 0,06	15 14

1.10 Double row deep groove ball bearings

d 70 – 90 mm

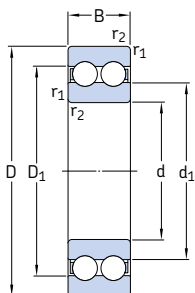

Principal dimensions			Basic load ratings		Fatigue load limit	Speed ratings		Mass	Designation
d	D	B	dynamic	static		Reference speed	Limiting speed		
mm			kN		kN	r/min		kg	–
70	125	31	70,2	73,5	3,1	8 000	4 300	1,5	4214 ATN9
	150	51	138	125	5	7 000	3 800	3,95	4314 ATN9
75	130	31	72,8	80	3,35	7 500	4 000	1,6	4215 ATN9
	160	55	156	143	5,5	6 700	3 600	4,8	4315 ATN9
80	140	33	80,6	90	3,6	7 000	3 800	2	4216 ATN9
85	150	36	93,6	102	4	7 000	3 600	2,55	4217 ATN9
90	160	40	112	122	4,65	6 300	3 400	3,2	4218 ATN9

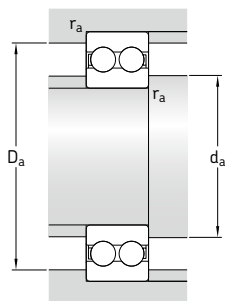

Dimensions				Abutment and fillet dimensions			Calculation factor	
d	d ₁ ~	D ₁ ~	r _{1,2} min.	d _a min.	D _a max.	r _a max.	k _r	f ₀
mm				mm			-	
70	89,4	106	1,5	79	116	1,5	0,05	15
	96,7	124	2,1	82	138	2	0,06	14
75	96,9	114	1,5	84	121	1,5	0,05	16
	103	132	2,1	87	148	2	0,06	14
80	102	120	2	91	129	2	0,05	16
85	105	125	2	96	139	2	0,05	15
90	114	136	2	101	149	2	0,05	15





2 Y-bearings (insert bearings)

Designs and variants	422	Temperature limits	446
Y-bearings with grub screws	424	Permissible speed	446
Basic design bearings	424	Design of bearing arrangements	447
Bearings with zinc-coated rings	424	Axial displacement	447
Stainless steel bearings	424	Shaft tolerances	450
Y-bearings with an eccentric locking collar	425	Mounting and dismounting	451
SKF ConCentra Y-bearings	426	Assembling Y-bearings into housings with fitting slots	454
Y-bearings with a tapered bore	427	SKF ConCentra Y-bearings	455
Y-bearings with a standard inner ring	428	Designation system	456
Cages	428	Product tables	
Sealing solutions	429	2.1 Y-bearings with grub screws, metric shafts	458
Standard seals	429	2.2 Y-bearings with grub screws, inch shafts	460
Standard seals with additional flingers	429	2.3 Y-bearings with an eccentric locking collar, metric shafts	464
Multiple seals	429	2.4 Y-bearings with an eccentric locking collar, inch shafts	466
5-lip seals	430	2.5 SKF ConCentra Y-bearings, metric shafts	468
Seals for SKF Energy Efficient Y-bearings	430	2.6 SKF ConCentra Y-bearings, inch shafts	469
RS1 seals	430	2.7 Y-bearings with a tapered bore on an adapter sleeve, metric shafts	470
Shields	431	2.8 Y-bearings with a tapered bore on an adapter sleeve, inch shafts	471
Greases for capped bearings	431	2.9 Y-bearings with a standard inner ring, metric shafts	472
Grease life for Y-bearings	432		
Relubrication	434		
Y-bearings for agricultural applications	435		
Rubber seating rings	436		
Performance classes	438		
SKF Energy Efficient (E2) bearings	438		
Bearing data	441		
(Dimension standards, tolerances, radial internal clearance, misalignment, friction, starting torque, power loss, defect frequencies)			
Loads	444		
(Minimum load, axial load carrying capacity, equivalent loads)			
		Other Y-bearings	
		Bearings for extreme temperatures	1169
		Bearings with Solid Oil	1185
		SKF DryLube bearings	1191
		Y-bearing units → SKF catalogue	
		<i>Y-bearings and Y-bearing units</i>	

Designs and variants

Y-bearings (insert bearings) are based on sealed deep groove ball bearings in the 62 and 63 series. Y-bearings typically have a sphered (convex) outside surface and an extended inner ring (→ **fig. 1**) with different locking devices to enable quick and easy mounting onto the shaft. The various Y-bearing series differ in the way the bearing is locked onto the shaft:

- with grub (set) screws (→ **fig. 2**)
- with an eccentric locking collar (→ **fig. 3**)
- with SKF ConCentra locking technology (→ **fig. 4**)
- with an adapter sleeve (→ **fig. 5**)
- with an interference fit (→ **fig. 6**)

The standard SKF Y-bearing assortment includes application specific variants:

- bearings made of stainless steel or with zinc-coated rings for the food industry (→ **page 424**)
- bearings for agricultural applications (→ **page 435**)
- bearings for extreme temperatures (→ **page 1169**)
- bearings with Solid Oil (→ **page 1185**)
- SKF DryLube bearings (→ **page 1191**)

Other variants are available on request. These include Y-bearings with:

- a cylindrical outer ring
- a customized design or dimensions
- a hexagonal or square bore
- a special cage
- special grease and special grease quantity
- a special coating

For additional information about these variants, contact the SKF application engineering service.

Y-bearing units

SKF also supplies a wide variety of Y-bearing units, but are not listed in this rolling bearing catalogue. For information about Y-bearing units, refer to the SKF catalogue *Y-bearings and Y-bearing units* or the product information available online at skf.com/bearings.

More information

Bearing life and load ratings. 63

Design considerations 159

Bearing systems. 160

Recommended fits 169

Abutment and fillet dimensions. 208

Lubrication 239

Mounting, dismantling and bearing care 271

SKF bearing maintenance handbook
..... (ISBN 978-91-978966-4-1)

Fig. 1

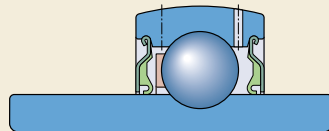

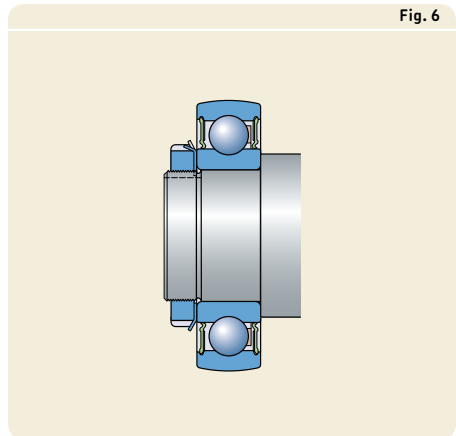
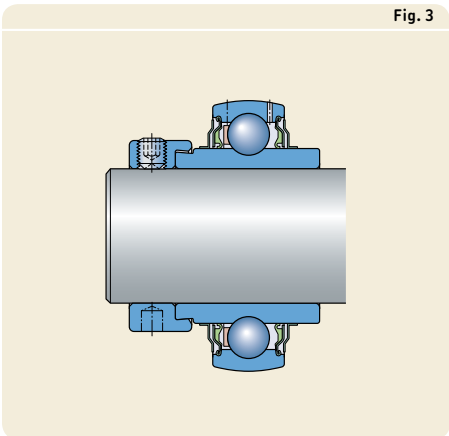
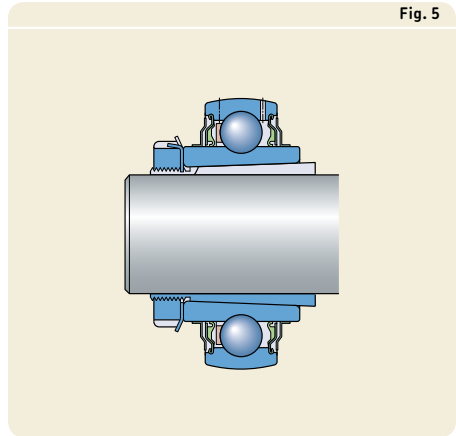
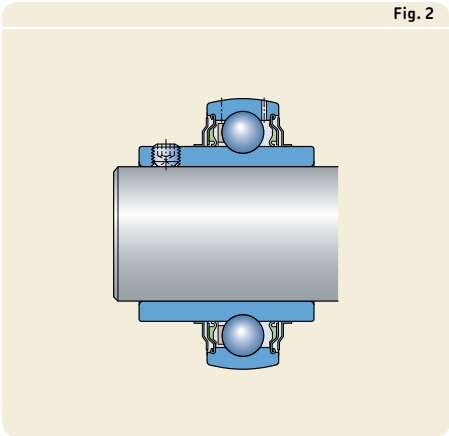
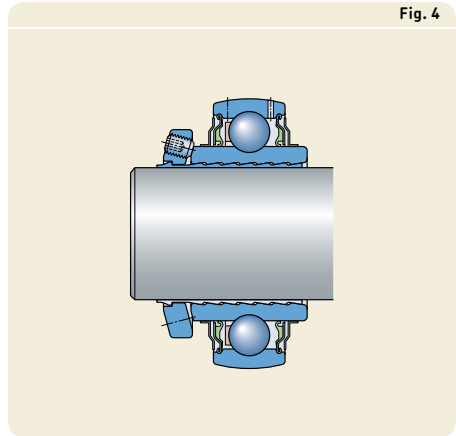

2 Y-bearings

Y-bearings with grub screws

Y-bearings with grub (set) screws in the inner ring are locked onto the shaft by tightening the two cup point hexagonal grub screws, positioned 120° apart. These bearings are suitable for applications for both constant and alternating direction of rotation.

Basic design bearings

Two different basic design Y-bearings with grub screws are available.

Y-bearings in the YAT 2 series (→ **fig. 7**) have an inner ring extended on one side.

Y-bearings in the YAR 2 series (→ **fig. 8**) have an inner ring extended on both sides. This reduces the extent to which the inner ring can tilt on the shaft, which enables the bearing to run more smoothly.

Bearings in both the YAT 2 and YAR 2 series are fitted with a rugged standard seal (→ *Standard seals*, **page 429**). Bearings in the YAR 2 series are fitted with an additional flinger on both sides. Flinger options are:

- a plain sheet steel flinger, designation suffix 2F
- a rubberized sheet steel flinger (multiple seal), designation suffix 2RF

Y-bearings in the YAT 2 and YAR 2 series have two lubrication holes in the outer ring as standard, one on each side, positioned 120° apart. Bearings without lubrication holes can be supplied on request (designation suffix W).

SKF YAT 2 and YAR 2 series bearings are available for metric shafts from 12 to 100 mm and for inch shafts from 1/2 to 3 inches.

Bearings with zinc-coated rings

Y-bearings with an inner ring extended on both sides are also available with zinc-coated rings for use in corrosive environments. Bearings in the YAR 2..-2RF/VE495 series are fitted with a highly effective multiple seal (→ *Multiple seals*, **page 429**) made of food-compatible rubber with a stainless steel insert and a stainless steel flinger on both sides. The grub screws are made of stainless steel. The bearings are filled with a food-grade grease and can be relubricated through one of the two lubrication holes in the outer ring. The lubrication holes are positioned 120° apart, one on each side.

SKF Y-bearings with zinc-coated rings are available for metric shafts from 20 to 50 mm and for inch shafts from 3/4 to 1 15/16 inches.

Stainless steel bearings

All steel components of these bearings are made of stainless steel, including rings, balls, sheet metal parts of both seals and flingers, and grub screws. The inner ring is extended on both sides. Bearings in the YAR 2..-2RF/HV series are fitted with a highly effective multiple seal (→ *Multiple seals*, **page 429**) made of food-compatible rubber with a stainless steel insert and a stainless steel flinger on both sides. They are filled with a food-grade grease and can be relubricated through the lubrication

Fig. 7

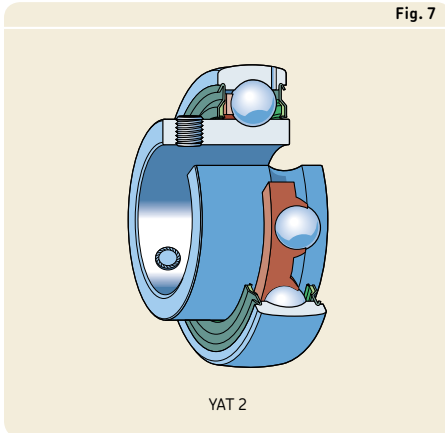
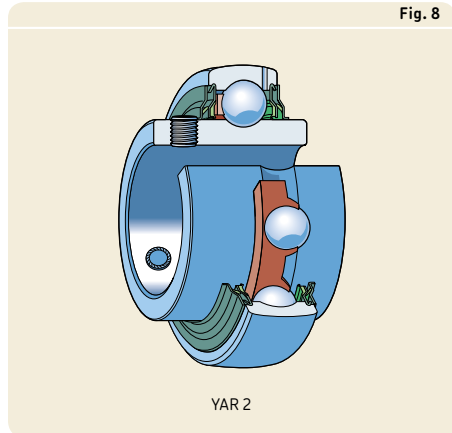

Fig. 8



hole in the outer ring groove. This lubrication groove is located on the side opposite the locking device.

The dynamic load carrying capacity of a stainless steel bearing is less than that of a same-sized bearing made of high grade carbon chromium steel.

SKF stainless steel Y-bearings are available for metric shafts from 20 to 50 mm and for inch shafts from $\frac{3}{4}$ to $1\frac{15}{16}$ inches.

Y-bearings with an eccentric locking collar

Y-bearings with an eccentric locking collar are intended primarily for use in applications where the direction of rotation is constant. On one side, the extended inner ring of the bearing has an eccentric step. The step accommodates the locking collar. Turning the locking collar in the direction of rotation locks the collar and bearing onto the shaft. A single grub screw further secures the collar to the shaft. The eccentric collar is zinc-coated for bearings with a metric bore and black oxidized for bearings with an inch bore. There are two standard series available from SKF.

Y-bearings in the YET 2 series have an inner ring extended on one side (→ **fig. 9**).

Y-bearings in the YEL 2 series have an inner ring extended on both sides (→ **fig. 10**). This reduces the extent to which the inner ring can tilt on the shaft, which enables the bearing to run more smoothly.

Bearings in both the YET2 and YEL 2 series are fitted with a rugged standard seal (→ *Standard seals*, **page 429**). Bearings in the YEL 2 series are fitted with an additional flinger on both sides. Flinger options are:

- a plain sheet steel flinger, designation suffix 2F
- a rubberized sheet steel flinger (multiple seal), designation suffix 2RF/VL065

Y-bearings in the YET 2 and YEL 2 series have two lubrication holes in the outer ring as standard, one on each side, positioned 120° apart. Bearings without lubrication holes can be supplied on request (designation suffix W).

SKF Y-bearings with an eccentric locking collar are available for metric shafts from 15 to 60 mm and for inch shafts from $\frac{1}{2}$ to $2\frac{7}{16}$ inches.

Fig. 9

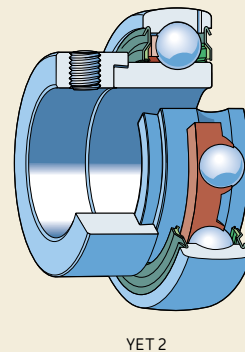

YET 2

Fig. 10

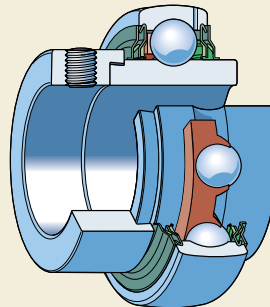

YEL 2

2 Y-bearings

SKF ConCentra Y-bearings

SKF ConCentra Y-bearings have an inner ring symmetrically extended on both sides (→ **fig. 11**). The patented SKF ConCentra locking technology is based on the expansion and contraction of two mating surfaces: the bearing bore and the external surface of the stepped sleeve. Both surfaces have precision-engineered serrations. When the grub screws in the mounting collar are tightened, the inner ring is displaced axially, relative to the stepped sleeve (→ **fig. 12**). This forces the bearing inner ring to expand and the stepped sleeve to contract evenly, providing a true concentric fit on the shaft. SKF ConCentra Y-bearings provide an easy, quick and reliable way to lock a bearing onto a shaft.

The true concentric fit on the shaft provides low noise and vibration levels and virtually eliminates fretting corrosion. Even more important is that the fit on the shaft does not loosen, even in applications where there are heavy loads and/or high speeds. The shaft tolerance does not limit the permissible bearing speed and the full limiting speed can be achieved, even when using commercial grade shafts. The bearings can be used in applications for both constant and alternating direction of rotation.

SKF ConCentra Y-bearings, series designation YSP 2, are equipped with a rugged standard seal on both sides, fitted with additional plain sheet steel flingers (→ *Standard seals with additional flingers*, **page 429**). The outer ring has two lubrication holes as standard, one

Fig. 11

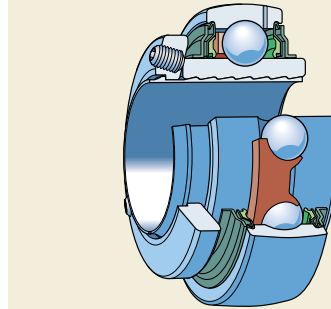

on each side, positioned 120° apart. Bearings without lubrication holes can be supplied on request (designation suffix W).

SKF Y-bearings in the YSP 2 series are available for metric shafts from 25 to 60 mm and for inch shafts from 1 to 2 ¹¹/₁₆ inches.

Fig. 12

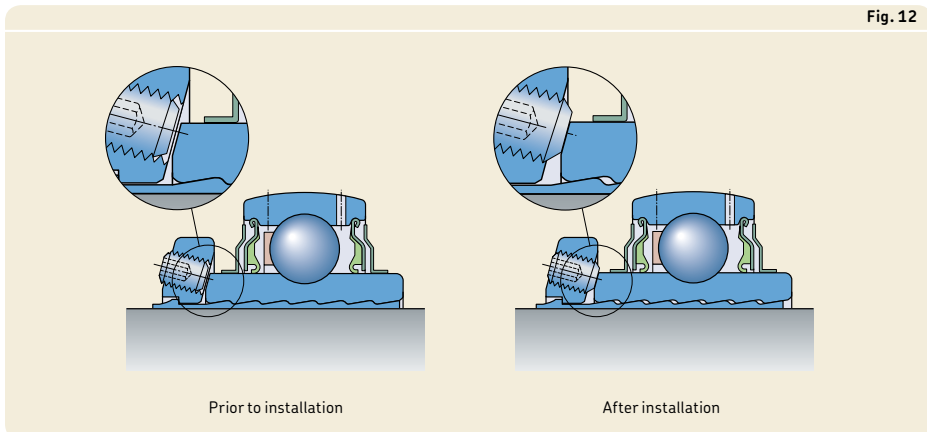

Y-bearings with a tapered bore

Y-bearings with a tapered bore (→ **fig. 13**) have an inner ring symmetrically extended on both sides and a tapered bore (taper 1:12) enabling them to be mounted on a standard H 23 series adapter sleeve. Mounting onto an adapter sleeve enables the bearings to run smoothly and the full limiting speed can be achieved, even when using commercial grade shafts. The bearings can be used in applications for both constant and alternating direction of rotation. The appropriate adapter sleeve is not part of the bearing and must be ordered separately.

Y-bearings with a tapered bore, series designation YSA 2, are equipped with a rugged standard seal, fitted with an additional plain sheet steel flinger on both sides (→ *Standard seals with additional flingers*, **page 429**). The outer ring has two lubrication holes as standard, one on each side, positioned 120° apart. Bearings without lubrication holes can be supplied on request (designation suffix W).

SKF Y-bearings in the YSA 2 series are available with bore diameters ranging from 25 to 65 mm, which fit adapter sleeves in the H 23 series for metric shafts ranging from 20 to 60 mm. These bearings can also be used on adapter sleeves in the HA 23, HE 23 and HS 23 series for inch shafts ranging from 3/4 to 2 3/8 inches.

Fig. 13

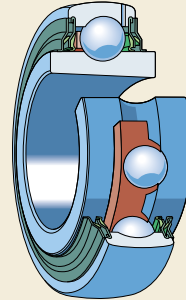

2 Y-bearings

Y-bearings with a standard inner ring

Y-bearings with a standard inner ring (→ **fig. 14**) have normal tolerances for the bearing bore diameter and are locked onto the shaft using an appropriate interference fit. These bearings in the 17262 and 17263 series have the same dimensions and features as deep groove ball bearings in the 62 and 63 series, but have a sphered (convex) outside surface. The bearings are suitable for applications where the direction of the load alternates and where smooth running is a key operational parameter. They can accommodate heavier axial loads than any other Y-bearings and can operate at the same speeds as a corresponding sealed deep groove ball bearing. They do not have any lubrication holes in the outer ring.

SKF Y-bearings with a standard inner ring are available for metric shafts from 17 to 60 mm.

Cages

Y-bearings are fitted as standard with a snap-type, glass fibre reinforced PA66 cage (→ **fig. 15**), no designation suffix.

The initial grease fill does not have a detrimental effect on cage properties. However, if other greases are used, note that some synthetic greases with a synthetic base oil and lubricants containing a high proportion of EP additives, when used at high temperatures, can have a detrimental effect on polyamide cages. For additional information about the suitability of cages, refer to *Cages* (→ **page 37**) and *Cage materials* (→ **page 152**).

Fig. 14

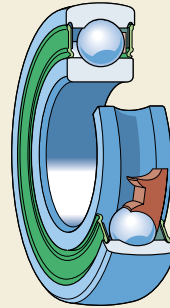

Fig. 15



Sealing solutions

SKF supplies all Y-bearings capped with a seal or shield on both sides. In typical Y-bearing applications, no additional external protection is necessary. Therefore, Y-bearings are available with several sealing arrangement designs to meet the demands of a wide range of operating conditions.

Standard seals

The standard seals for Y-bearings (no designation suffix) consist of a stamped sheet steel washer with a seal lip made of NBR, vulcanized to its inner surface (→ **fig. 16**). The non-contact sheet steel washer forms a narrow gap with the cylindrical surface of the inner ring shoulder and protects the seal against coarse contaminants.

Standard seals with additional flingers

For more contaminated environments, SKF recommends Y-bearings equipped with a standard seal and an additional plain flinger on both sides (→ **fig. 17**, designation suffix 2F). The flinger, made of sheet steel or stainless sheet steel, has an interference fit on the inner ring to considerably improve the effectiveness of the seal without increasing friction. These seals are only available for bearings with an inner ring extended on both sides.

Multiple seals

For very contaminated environments, SKF recommends Y-bearings equipped with the highly effective multiple seal on both sides (→ **fig. 18**, designation suffix 2RF). This sealing arrangement consists of a standard seal and a flinger with a vulcanized NBR lip. The flinger lip seals axially against the standard seal. The space between the flinger lip and the shaft is filled with grease to provide additional protection. These seals are only available for bearings with an inner ring extended on both sides.

Fig. 16

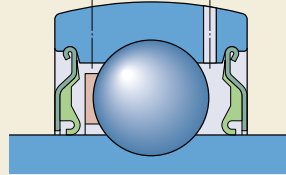

Fig. 17

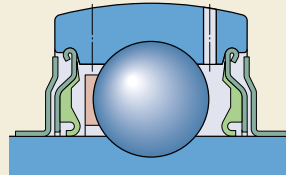
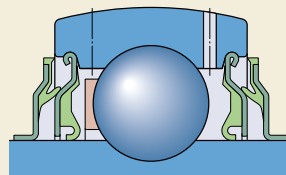

Fig. 18



2 Y-bearings

5-lip seals

For extremely contaminated environments, such as agricultural applications, SKF recommends Y-bearings equipped with the patented 5-lip seal on both sides (→ fig. 19). The seal consists of a sheet steel insert with a vulcanized 5-lip contact seal made of a low-friction NBR compound. The steel insert, which protects the seal from solid contaminants, is held in place by a groove in the bearing outer ring. Each seal lip has a different design to provide superior sealing performance in response to different operating conditions, including dynamic misalignment. The outermost and innermost lips act as a labyrinth to prevent contaminant ingress and grease leakage respectively. The three inner lips make constant contact with the inner ring shoulder.

Seals for SKF Energy Efficient Y-bearings

These seals minimize the frictional moment in SKF Energy Efficient Y-bearings while providing effective protection in less contaminated environments. The seals are made of NBR and are sheet steel reinforced. The lip has an innovative thin and flexible design (→ fig. 20). They are fitted in a recess on the outer ring and seal against the inner ring shoulder. The sheet steel insert protects against solid contaminants.

Depending on the bearing series, the sealing effect can be enhanced by adding plain sheet steel flingers (designation suffix 2F). The flingers have an interference fit on the inner ring and do not increase friction.

RS1 seals

Y-bearings with a standard inner ring are equipped with an RS1 seal on both sides. These NBR contact seals, developed for standard SKF deep groove ball bearings, are reinforced with a sheet steel insert (→ fig. 21, designation suffix 2RS1). They are fitted in a recess on the outer ring and ride against the inner ring shoulder.

Fig. 19

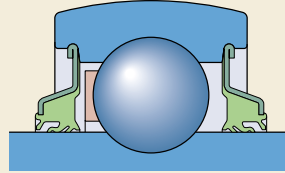

Fig. 20

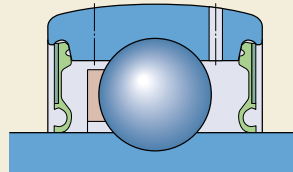
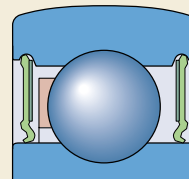
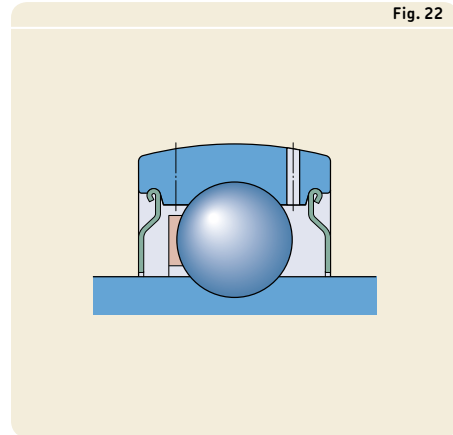

Fig. 21



Shields

On request, Y-bearings can be supplied with a shield on both sides. The sheet steel shields are fitted in a recess on the outer ring and do not make contact with the inner ring, but form a narrow gap (→ **fig. 22**, designation suffix VP076). They are designed for applications where the contamination level is low and additional friction should be avoided. Bearings with shields should not be used if water, steam or moisture can enter the bearing.



Greases for capped bearings

Y-bearings are filled with one of the following greases:

- SKF Energy Efficient Y-bearings
→ low-friction grease GE2
- zinc-coated and stainless steel Y-bearings
→ food-grade grease GFJ
This grease fulfils the requirements listed in the Guidelines of section 21 CFR 178.3570 of the FDA (US Food and Drug Administration) regulations. It is approved by the USDA (United States Department of Agriculture) for Category H1 use (occasional contact with food stuffs).
- all other Y-bearings
→ standard grease VT307

The technical specifications for the various greases are listed in **table 1**.

Table 1

Grease	Temperature range ¹⁾	Thickener	Base oil type	NLGI consistency class	Base oil viscosity [mm ² /s]	
					at 40 °C (105 °F)	at 100 °C (210 °F)
VT307		Lithium-calcium soap	Mineral	2	190	15
GFJ		Aluminium-complex soap	Synthetic hydrocarbon	2	100	14
GE2		Lithium soap	Synthetic	2	25	4,9

-60 30 120 210 300 390 480 °F

¹⁾ Refer to the SKF traffic light concept → **page 244**

2 Y-bearings

Grease life for Y-bearings

Grease life for Y-bearings should be estimated according to the procedure described in this section. The grease life for Y-bearings is presented as L_{10} , i.e. the time period at the end of which 90% of the bearings are still reliably lubricated. When relubrication is required, the method to estimate relubrication intervals is described on **page 252** under *Relubrication intervals*. For additional information see *Relubrication* (→ **page 434**).

The grease life for Y-bearings depends on the operating temperature and the speed factor. It can be obtained from the diagrams.

Diagram 1 is valid for Y-bearings filled with VT307 grease or GFJ food-grade grease.

Diagram 2 is valid for SKF Energy Efficient Y-bearings.

The grease life for each is valid under the following operating conditions:

- horizontal shaft
- very light to moderate loads ($P \leq 0,05 C$)
- stationary machine
- low vibration levels

If operating conditions differ, the grease life obtained from the diagrams has to be adjusted:

- For vertical shafts, use 50% of the value from the diagram.
- For heavier loads ($P > 0,05 C$), use the reduction factor listed in **table 3**.

The values for adjusting the grease life are estimates. Vibration can have a negative influence on grease life. The extent cannot be quantified, and the influence increases with increasing operating temperature. For additional information, refer to *Lubrication* (→ **page 239**) or contact the SKF application engineering service.

Table 2

Bearing mean diameter d_m

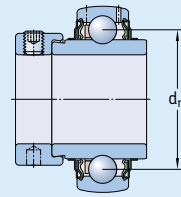

Bearing size ¹⁾	Bearing mean diameter d_m
----------------------------	-----------------------------

–	mm
03	28,5
04	33,5
05	39
06	46
07	53,5
08	60
09	65
10	70
11	77,5
12	85
13	92,5
14	97,5
15	102,5
16	110
17	117,5
18	126
20	141

¹⁾ For example: bearing size 06 includes all bearings based on a Y 206 bearing, such as YAR 206-101-2F, YAR 206-102-2F, YAR 206-2F, YAR 206-103-2F, YAR 206-104-2F

Table 3

Reduction factor for the grease life, depending on the load

Load P	Reduction factor
$\leq 0,05 C$	1
0,1 C	0,7
0,125 C	0,5
0,25 C	0,2

Diagram 1

Grease life for Y-bearings with VT307 or GFJ grease
 where load $P = 0,05 C$

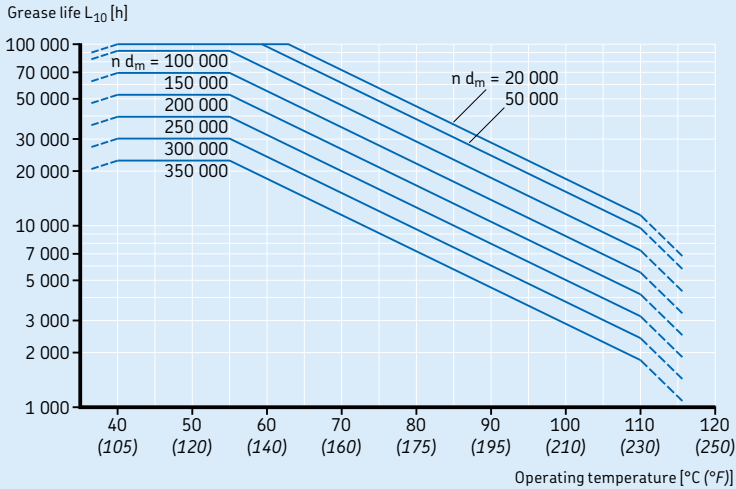

n = rotational speed [r/min]
 d_m = mean diameter [mm] → table 2

Diagram 2

Grease life for SKF Energy Efficient Y-bearings
 where load $P = 0,05 C$

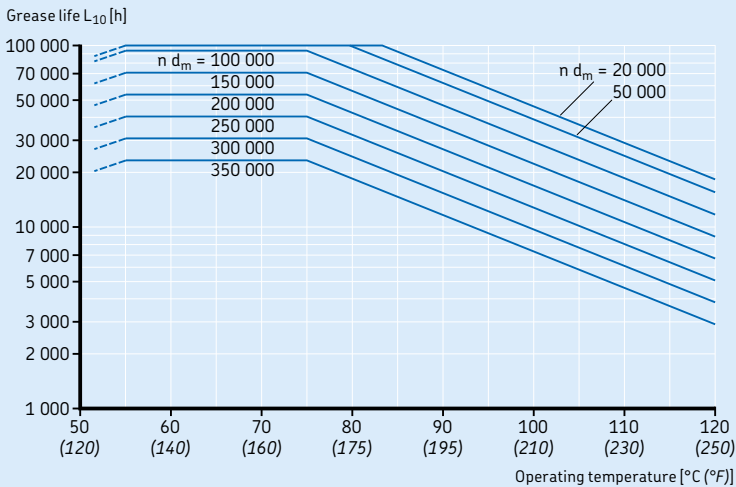

n = rotational speed [r/min]
 d_m = mean diameter [mm] → table 2

2 Y-bearings

Relubrication

Y-bearings do not need relubrication when the grease life (→ *Grease life for Y-bearings*, **page 432**) exceeds the SKF rating life of the bearing (→ *Selecting bearing size*, **page 61**).

Relubrication can extend bearing service life under any of the following conditions:

- The bearings are exposed to high humidity or severe contamination.
- The bearings accommodate normal or heavy loads.
- The bearings operate for extended periods at high speeds or at temperatures above 55 °C (130 °F), above 75 °C (170 °F) for SKF Energy Efficient Y-bearings.
- The bearings are subjected to high vibration levels.

To relubricate Y-bearings, the following greases can be used:

- SKF Energy Efficient Y-bearings
→ exclusively low-friction grease SKF LEGE 2
- zinc-coated and stainless steel Y-bearings
→ food-grade grease SKF LGFP 2
- all other Y-bearings
→ SKF LGWA 2, LGMT 2 or LGMT 3 grease

If relubrication is needed, the relubrication intervals can be estimated following the method explained under *Relubrication intervals* (→ **page 252**).

When relubricating, the shaft should be turned and grease should be pumped slowly until fresh grease starts to escape from the seal(s). Excessive pressure from pumping too quickly can damage the seals. When machines and equipment are used for a limited period of time, SKF recommends relubricating each bearing at the end of the operational period, i.e. immediately before being laid up.

Relubrication features

SKF Y-bearings are designed to facilitate relubrication. They have two lubrication holes in the outer ring as standard, one on each side, positioned 120° apart. Bearings without lubrication holes can be supplied on request (designation suffix W).

The following bearings do not have the standard relubrication features:

- Stainless steel Y-bearings with grub screws have a lubrication groove in the outer ring located on the side opposite the locking device and one lubrication hole within this groove.
- Y-bearings with a standard inner ring and Y-bearings for agricultural applications are lubricated for life and cannot be relubricated. They do not have any lubrication holes.

Y-bearings for agricultural applications

Y-bearings for agricultural applications are designed to withstand the demanding operating conditions that occur in machinery like combines and balers, harvesters and disk harrows. Extensive laboratory tests and field experience confirm that these bearings outlast conventional bearings, which typically have a one to three year life span.

Y-bearings for agricultural applications are equipped with a patented 5-lip seal on both sides (→ **page 430**). The bearings are lubricated for life with VT307 grease (→ **table 1, page 431**). The grease has a high resistance to water washout, enabling long bearing service life in wet environments. The bearings cannot be relubricated.

Y-bearings for agricultural applications are dimensionally interchangeable with standard Y-bearings, enabling easy upgrades of existing applications to reduce machine downtime and environmental impact. SKF Y-bearings for agricultural applications are available for metric shafts from 20 to 50 mm and for inch shafts from 1 to 1 ¹⁵/₁₆ inches. The bearings are available with three different locking methods (→ **fig. 23**):

- Y-bearings in the YARAG 2 series, which are interchangeable with bearings in the YAR 2 series, are locked onto the shaft with two grub screws. They are typically used for moderate loads.
- Y-bearings in the YELAG 2 series, which are interchangeable with bearings in the YEL 2 series, are locked onto the shaft by an eccentric locking collar. The eccentric collar is black oxidized. The bearings are typically used for moderate loads.
- Y-bearings in the YSPAG 2 series, which are interchangeable with bearings in the YSP 2 series, are locked onto the shaft by the patented SKF ConCentra locking technology. This locking technology enables the bearing to accommodate heavier loads than other locking methods.

Other Y-bearings for agricultural applications are available on request:

- bearings with zinc-coated rings
- bearings with a cylindrical outer ring
- bearings with other locking methods

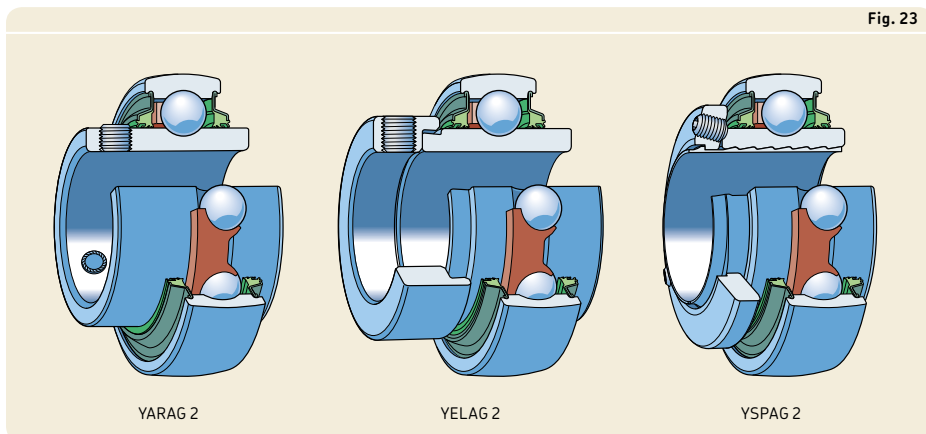

2 Y-bearings

Rubber seating rings

Rubber seating rings in the RIS 2 series (→ **fig. 24**) are primarily intended to “cushion” Y-bearings in stamped steel plummer block housings. Located on the bearing outer ring and in housing bore (→ **fig. 25**), they are intended to dampen vibration and noise and enable the bearings to be displaced slightly in their housings to accommodate minor shaft elongation or misalignment.

The seating rings in the RIS 2 series are made of NBR and have a sphered (convex) outside surface. The rings can withstand temperatures ranging from -30 to $+100$ °C (-20 to $+210$ °F). The designations and dimensions for rubber seating rings are listed in **table 4**.

Rubber seating rings are available as an accessory and must be ordered separately. They can be fitted on all SKF Y-bearings, except for Y-bearings with a standard inner ring (17262 and 17263 series). However, Y-bearings in the YET 2 series can be supplied with the seating ring already fitted (→ **fig. 26**). These products are identified by the series prefix **CYS**, followed by the bearing bore diameter and the bearing identification suffix **FM**. E.g. **CYS 20 FM** is a YET 204 bearing with a 20 mm bore, fitted with an RIS 204 rubber seating ring.

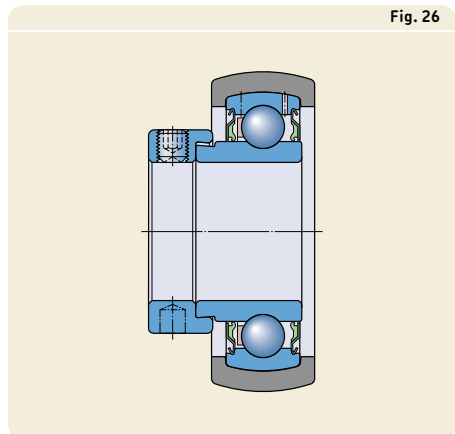
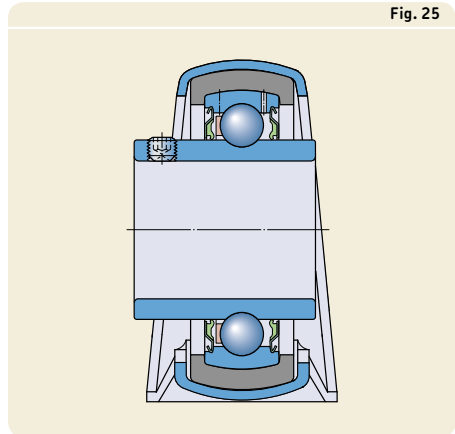
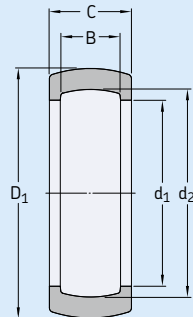

Table 4

Rubber seating rings



Y-bearing Outside diameter D	Size	Rubber seating ring Designation	Dimensions			B	C	Mass
mm	–	–	D_1 mm	d_1	d_2			g
40	03	RIS 203	47,3	35,5	39,8	12	18	12
47	04	RIS 204	52,3	41,2	46,8	14	19	11,5
52	05	RIS 205	62,3	46,4	51,8	15	20,5	26,5
62	06	RIS 206 A	72,3	54,6	61,8	18	21,5	31
72	07	RIS 207 A	80,3	63,7	71,8	19	23	32
80	08	RIS 208 A	85,3	70,7	79,7	21	24	26

Performance classes

SKF Energy Efficient (E2) bearings

To meet the ever-increasing demand to reduce friction and energy use, SKF has developed the SKF Energy Efficient (E2) performance class of rolling bearings. Y-bearings within this performance class are characterized by a frictional moment in the bearing that is at least 50% lower when compared to a same-sized standard Y-bearing.

This substantial reduction of the frictional moment was achieved by a new contact seal and applying a new, low-friction grease. Due to the reduction of the frictional moment, SKF E2 Y-bearings run up to 30 °C (55 °F) cooler than standard bearings. This extends grease life and potentially bearing service life.

SKF E2 Y-bearings are dimensionally interchangeable with standard bearings enabling both, easy upgrades of existing applications as well as improving the energy efficiency of new applications. Typical applications include conveyors, industrial fans and textile machinery.

SKF E2 Y-bearings are available in the YAR 2, YET 2 and SKF ConCentra YSP 2 series. Bearings in the YET 2 series are supplied with a contact seal on both sides (→ **page 430**). Bearings in the YAR 2 and YSP 2 series are equipped with a contact seal and a plain sheet steel flinger on both sides, improving the sealing effect without increasing friction. The good performance of the seal combined with the cooler running and the extended grease life enable SKF E2 Y-bearings to operate without relubrication under normal operating conditions. When necessary, they can be relubricated through the outer ring (→ *Relubrication*, **page 434**).

Bearing data

	Y-bearings with grub screws (series YAT 2, YAR 2, YARAG 2)	with an eccentric locking collar (series YET 2, YEL 2, YELAG 2)
Dimension standards	Boundary dimensions: ISO 9628 Bearings in the YAT 2 series are not standardized. However, the bore and outside diameter and the outer ring width are in accordance with ISO 9628.	Boundary dimensions: ISO 9628
Tolerances For additional information (→ page 132)	Values for the bore and outside diameter: (→ table 5, page 442) The values for bore and outside diameter tolerances are slightly tighter than those listed in ISO 9628.	
Radial internal clearance For additional information (→ page 149)	ISO 9628 – Group N Values: (→ table 6, page 442) Values are valid for unmounted bearings under zero measuring load.	
Misalignment	<p>Static misalignment</p> <p>Y-bearings can accommodate initial misalignment by tilting in the housing (→ fig. 27, page 443), because of their sphered outside surface. The permissible values depend on the housing type:</p> <ul style="list-style-type: none"> • SKF cast iron and composite housings <ul style="list-style-type: none"> – relubrication is not required → 5° – relubrication is required → 2° 	
Friction, starting torque, power loss	Frictional moment, starting torque and power loss can be calculated ...	
Defect frequencies	Defect frequencies can be calculated using the tools available online ...	

with SKF ConCentra locking technology (series YSP 2, YSPAG 2)	with a tapered bore (series YSA 2)	with a standard inner ring (series 17262, 17263)
Boundary dimensions: not standardized However, the outside diameter and the outer ring width are in accordance with ISO 9628.	Boundary dimensions: JIS B 1558 Adapter sleeves in the H 23 series: ISO 2982-1	Boundary dimensions: ISO 15, except for the sphered outside surface
Values for the outside diameter: (→ table 5, page 442) Before mounting, the sleeve bore is larger than the nominal value to ease sliding on the shaft.	Values for the outside diameter:(→ table 5, page 442) The tapered bore fits H23 series adapter sleeves, for metric and inch shafts.	Normal Values: ISO 492 (→ table 3, page 137), except for the sphered outside surface (→ table 5, page 442)
ISO 9628 – Group 3 Values: (→ table 6, page 442)		Normal Values: ISO 5753-1 (→ table 6, page 314)

- SKF stamped steel housings
Misalignment cannot be accommodated once the attachment bolts have been fully tightened, unless a rubber seating ring is used (→ **page 436**).

Dynamic misalignment

Y-bearings can accommodate a few minutes of arc (misalignment) between the inner and outer rings.

... using the tools available online at skf.com/bearingcalculator.

... at skf.com/bearingcalculator.

2 Y-bearings

Table 5

Tolerances for SKF Y-bearings

Nominal diameter		Inner ring Bearing series YAT 2, YAR 2, YARAG 2, YET 2, YEL 2, YELAG 2		Outer ring All bearings	
d, D over	incl.	Δ_{dmp} high	low	Δ_{Dmp} high	low
mm		μm		μm	
10	18	+15	+5	–	–
18	31,75	+18	+5	–	–
31,75	50,8	+19	+5	0	–10
50,8	80,962	+21	+5	0	–10
80,962	120	+25	+5	0	–15
120	150	–	–	0	–15
150	180	–	–	0	–20

d = nominal bore diameter

Δ_{dmp} = deviation of the mean bore diameter from the nominal

D = nominal outside diameter

Δ_{Dmp} = deviation of the mean outside diameter from the nominal

Table 6

Radial internal clearance for Y-bearings

Bearing size ¹⁾		Radial internal clearance of Y-bearings in the series			
from	to	YAT 2, YAR 2, YARAG 2, YET 2, YEL 2, YELAG 2		YSP 2, YSPAG 2, YSA 2	
		min.	max.	min.	max.
–		μm			
03	03	10	25	–	–
04	04	12	28	–	–
05	06	12	28	23	41
07	08	13	33	28	46
09	10	14	36	30	51
11	13	18	43	38	61
14	16	20	51	–	–
17	20	24	58	–	–

¹⁾ For example: bearing size 06 includes all bearings based on a Y 206 bearing, such as YAR 206-101-2F, YAR 206-102-2F, YAR 206-2F, YAR 206-103-2F, YAR 206-104-2F

Fig. 27

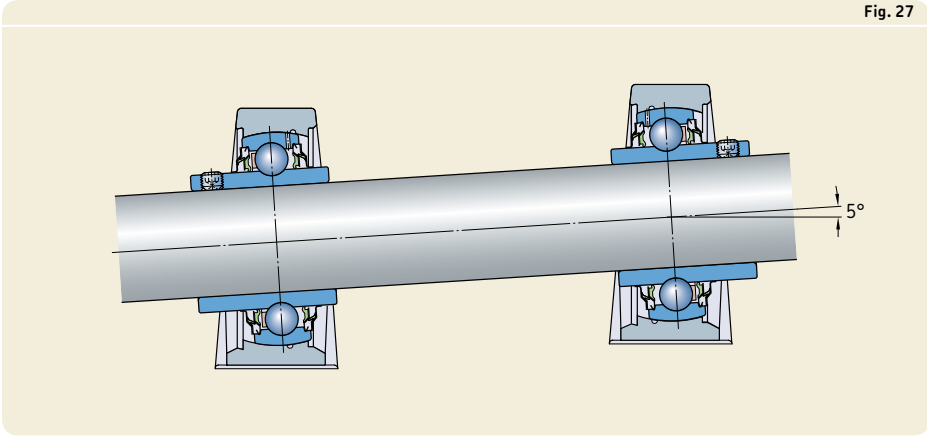

Loads

		Symbols
<p>Minimum load</p> <p>For additional information (→ page 86)</p>	<p>$F_{rm} = 0,01 C$</p> <p>The importance of imposing a minimum load increases where accelerations in the bearing are high, and where speeds are in the region of 75% or more of the limiting speed quoted in the product tables. The weight of the components supported by the Y-bearing, together with external forces, generally exceed the requisite minimum load.</p>	<p>C = basic dynamic load rating (→ product tables)</p> <p>C_0 = basic static load rating (→ product tables)</p> <p>e = limiting value (→ table 7)</p> <p>f_0 = calculation factor (→ table 8)</p> <p>F_a = axial load [kN]</p> <p>F_r = radial load [kN]</p> <p>F_{rm} = minimum radial load [kN]</p> <p>P = equivalent dynamic bearing load [kN]</p>
<p>Axial load carrying capacity</p>	<p>$F_a \leq 0,25 C_0$</p> <p>The maximal permissible axial load of any locking mechanism is always $> 0,25 C_0$.</p>	<p>P_0 = equivalent static bearing load [kN]</p> <p>X = radial load factor (→ table 7)</p> <p>Y = axial load factor (→ table 7)</p>
<p>Equivalent dynamic bearing load</p> <p>For additional information (→ page 85)</p>	<p>$F_a/F_r \leq e \rightarrow P = F_r$</p> <p>$F_a/F_r > e \rightarrow P = X F_r + Y F_a$</p>	
<p>Equivalent static bearing load</p> <p>For additional information (→ page 88)</p>	<p>$P_0 = 0,6 F_r + 0,5 F_a$</p>	

Table 7

Calculation factors						
$f_0 F_a/C_0$	Bearing series			17262, 17263		
	e	X	Y	e	X	Y
0,172	0,29	0,46	1,88	0,19	0,56	2,3
0,345	0,32	0,46	1,71	0,22	0,56	1,99
0,689	0,36	0,46	1,52	0,26	0,56	1,71
1,03	0,38	0,46	1,41	0,28	0,56	1,55
1,38	0,4	0,46	1,34	0,3	0,56	1,45
2,07	0,44	0,46	1,23	0,34	0,56	1,31
3,45	0,49	0,46	1,1	0,38	0,56	1,15
5,17	0,54	0,46	1,01	0,42	0,56	1,04
6,89	0,54	0,46	1	0,44	0,56	1

Table 8

Calculation factor f_0	
Bearing series sizes	Factor f_0
YAT 2, YAR 2, YARAG 2, YET 2, YEL 2, YELAG 2, YSP 2, YSPAG 2, YSA 2	
03-04	13
05-12	14
13-18	15
20	14
17262	
03-04	13
05-12	14
17263	
05	12
06-10	13

Temperature limits

The permissible operating temperature for Y-bearings can be limited by:

- the dimensional stability of the bearing rings and balls
- the cage
- the seals
- the lubricant

When temperatures outside the permissible range are expected, contact the SKF application engineering service.

Bearing rings and balls

Y-bearings undergo a special heat treatment. The bearing rings and balls are heat stabilized up to at least 150 °C (300 °F).

Cages

For temperature limits of PA66 cages, refer to *Cage materials* (→ page 152).

Seals

The permissible operating temperature for NBR seals is -40 to +100 °C (-40 to +210 °F). Temperatures up to 120 °C (250 °F) can be tolerated for brief periods.

Lubricants

Temperature limits for the greases used in Y-bearings are provided in **table 1** (→ page 431). Temperature limits for other SKF greases are provided under *Lubrication* (→ page 239).

When using lubricants not supplied by SKF, the temperature limits should be evaluated according to the SKF traffic light concept (→ page 244).

Permissible speed

Y-bearings should not operate at speeds above the limiting speed listed in the product tables. This speed limit is set by the seals. For Y-bearings with grub screws or an eccentric locking collar, the permissible speed is also influenced by the shaft tolerance. When using these bearings on shafts with wider tolerances than h6, compare the speed values listed in the product tables with those in **table 9**. The lower value is the permissible speed.

The permissible speed of Y-bearings for agricultural applications is valid under the following conditions:

Table 9

Permissible speeds for Y-bearings with grub screws or an eccentric locking collar

Bearing size ¹⁾	Permissible speed for shafts machined to tolerance class			
	h7(Ⓔ)	h8(Ⓔ)	h9(Ⓔ)	h11(Ⓔ)
–	r/min			
03	6 000	4 300	1 500	950
04	5 300	3 800	1 300	850
05	4 500	3 200	1 000	700
06	4 000	2 800	900	630
07	3 400	2 200	750	530
08	3 000	1 900	670	480
09	2 600	1 700	600	430
10	2 400	1 600	560	400
11	2 000	1 400	500	360
12	1 900	1 300	480	340
13	1 700	1 100	430	300
14	1 600	1 000	400	280
15	1 500	950	380	260
16	1 400	900	360	240
17	1 300	850	340	220
18	1 200	800	320	200
20	1 100	750	300	190

¹⁾ For example: bearing size 06 includes all bearings based on a Y 206 bearing, such as YAR 206-2F, YAR 206-101-2F, YAR 206-102-2F, YAR 206-103-2F, YAR 206-104-2F

- outer ring temperature $\leq 60\text{ }^{\circ}\text{C}$ ($140\text{ }^{\circ}\text{F}$)
- environment temperature $\leq 25\text{ }^{\circ}\text{C}$ ($80\text{ }^{\circ}\text{F}$)
- very light to moderate loads ($P \leq 0,05\text{ C}$)
- cast iron housing

For other conditions, contact the SKF application engineering service.

For applications operating at elevated speeds or when low vibration levels or quiet running are required, use SKF ConCentra Y-bearings, Y-bearings on an adapter sleeve or Y-bearings with a standard inner ring.

Design of bearing arrangements

Axial displacement

Y-bearings are not intended to accommodate axial displacement of the shaft relative to the housing. The distance between bearing positions should therefore be short to avoid excessive induced axial loads as a result of thermal elongation of the shaft.

Design for small axial displacement

To accommodate small axial displacement, the bearings should be supported by resilient sheet metal support surfaces or walls (\rightarrow fig. 28).

Fig. 28

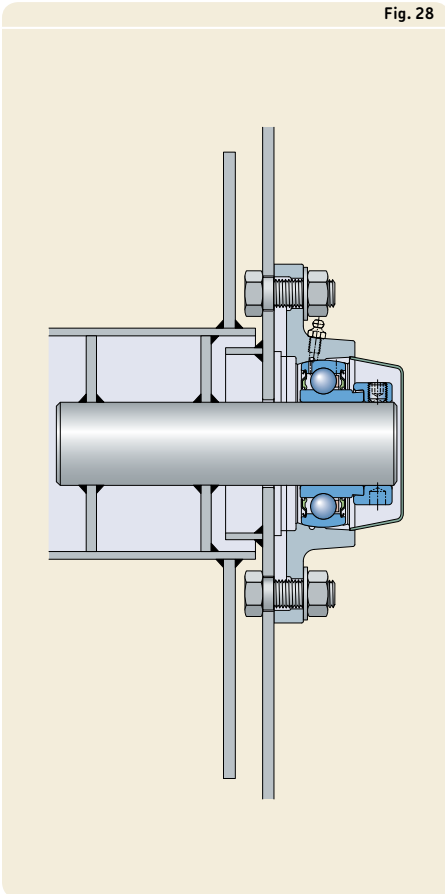

2 Y-bearings

Design for larger axial displacement

In applications where there are slow speeds and light loads, a Y-bearing with grub screws can be used to accommodate axial displacement. The shaft at the non-locating bearing position should be provided with one or two grooves 120° apart, to engage a modified grub screw:

- Hexagon socket grub (set) screws with a dog point, in accordance with ISO 4028, but with a fine thread according to **table 10**. The grub screw should be secured by a nut and spring washer or star lock washer (→ **fig. 29**).
- Slotted pan head screws in accordance with ISO 1580, but with fine thread according to **table 10**, locked with a spring or star lock washer (→ **fig. 30**).

The screws and groove(s) accommodate changes in shaft length and prevent the shaft from turning independently of the bearing. The ends of the grub screws should be ground and the sliding surfaces in the shaft grooves coated with a lubricant paste.

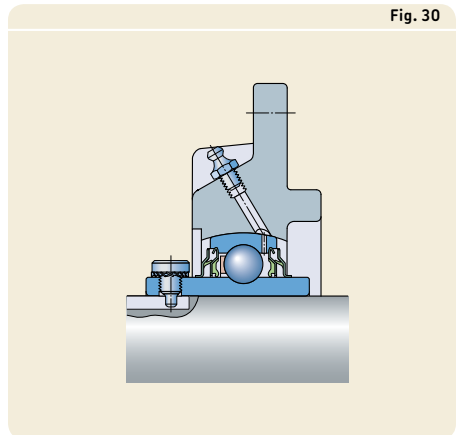
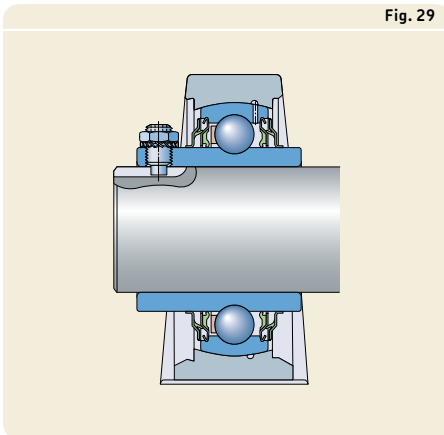
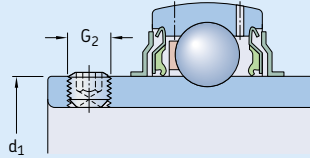

Table 10

Threaded holes in the inner ring of bearings in the YAT 2, YAR 2 and YARAG 2 series



Bearing size ¹⁾	Outside diameter of inner ring	Threaded holes	YAR bearing with	YAT bearing with	YAT bearing with
	d_1	YAR bearing with metric bore G_2	inch bore G_2	metric bore G_2	inch bore G_2
–	mm	–	–	–	–
03	24,2	M 6x0,75	#10-32 UNF	M 6x0,75	#10-32 UNF
04	28,2	M 6x0,75	1/4-28 UNF	M 6x0,75	1/4-28 UNF
05	33,7	M 6x0,75	1/4-28 UNF	M 6x0,75	1/4-28 UNF
06	39,7	M 6x0,75	1/4-28 UNF	M 6x0,75	5/16-24 UNF
07	46,1	M 6x0,75	5/16-24 UNF	M 6x0,75	5/16-24 UNF
08	51,8	M 8x1	5/16-24 UNF	M 6x0,75	5/16-24 UNF
09	56,8	M 8x1	5/16-24 UNF	M 6x0,75	5/16-24 UNF
10	62,5	M 10x1	3/8-24 UNF	M 8x1	3/8-24 UNF
11	69,1	M 10x1	3/8-24 UNF	–	3/8-24 UNF
12	75,6	M 10x1	3/8-24 UNF	–	3/8-24 UNF
13	82,5	M 10x1	3/8-24 UNF	–	–
14	87	M 10x1	7/16-20 UNF	–	–
15	92	M 10x1	7/16-20 UNF	–	3/8-24 UNF
16	97,4	M 10x1	7/16-20 UNF	–	3/8-24 UNF
17	105	M 12x1,5	–	–	–
18	112,5	M 12x1,5	–	–	–
20	124,8	M 12x1,5	–	–	–

¹⁾ For example: bearing size 06 includes all bearings based on a Y 206 bearing, such as YAR 206-101-2F, YAR 206-102-2F, YAR 206-2F, YAR 206-103-2F, YAR 206-104-2F

2 Y-bearings

Shaft tolerances

Recommended fits for Y-bearings are listed in **table 11**. **Fig. 31** illustrates the relative position of the upper and lower limits of the most commonly used ISO shaft tolerance classes for Y-bearings with grub (set) screws or an eccentric locking collar. The values for these tolerance classes are listed in **table 12**.

For Y-bearings on an adapter sleeve or SKF ConCentra Y-bearings the total radial run-out of the shaft seat should be IT5/2 for tolerance class h9 \oplus . The values for the ISO tolerance class h9 are listed in **table 12**.

For Y-bearings with a standard inner ring, the same recommendations apply as for standard deep groove ball bearings (\rightarrow **table 11**). The values for these ISO tolerance classes are listed in **table 7** (\rightarrow **page 178**).

Table 11

Recommended fits	
Operating conditions	Tolerance class ¹⁾
Y-bearings with grub screws or an eccentric locking collar	
P > 0,05 C and/or high speeds	h6
0,035 C < P \leq 0,05 C	h7
0,02 C < P \leq 0,035 C and/or slow speeds	h8
Simple bearing arrangements or P \leq 0,02 C	h9 – h11
Y-bearings with a tapered bore on an adapter sleeve or SKF ConCentra Y-bearings	
All loads and speeds	h9/IT5
Y-bearings with a standard inner ring	
P > 0,035 C	
Shaft diameter \leq 17 mm	j5
Shaft diameter \geq 20 mm	k5
P \leq 0,035 C	
Shaft diameter \geq 20 mm	j6

¹⁾ All ISO tolerance classes are valid with the envelope requirement (such as h7 \oplus) in accordance with ISO 14405-1.

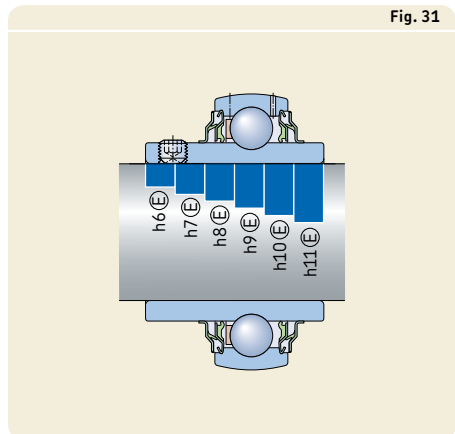

Mounting and dismounting

When mounting Y-bearings on a shaft, suitable tools should be used and the locking components should be tightened to the torque values / tightening angles listed in **tables 13 to 15** (→ **pages 452 to 454**).

For SKF ConCentra Y-bearings, mounting kits are available from SKF (designation 626830), which include mounting instructions, hexagonal keys and torque indicators. The correct tightening torque is achieved when the long end of the hexagonal key comes in contact with the torque indicator (→ **fig. 32**).

For additional information about mounting and dismounting Y-bearings and assembling Y-bearing units, refer to the *SKF bearing maintenance handbook*.

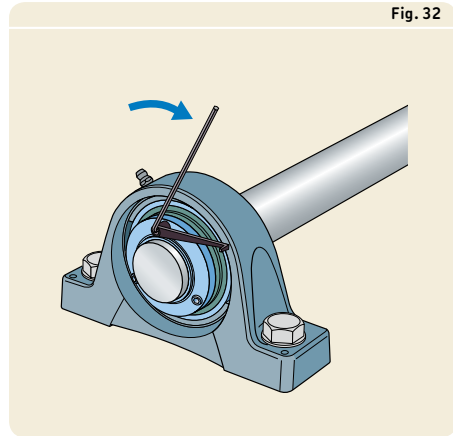

Fig. 32

Table 12

ISO shaft deviations for Y-bearings, except for Y-bearings with a standard inner ring

Shaft diameter d		Shaft diameter deviations											
		Tolerance class h6(E) Deviation		h7(E)		h8(E)		h9(E)		h10(E)		h11(E)	
over	incl.	high	low	high	low	high	low	high	low	high	low	high	low
-		µm											
10	18	0	-11	0	-18	0	-27	0	-43	0	-70	0	-110
18	30	0	-13	0	-21	0	-33	0	-52	0	-84	0	-130
30	50	0	-16	0	-25	0	-39	0	-62	0	-100	0	-160
50	80	0	-19	0	-30	0	-46	0	-74	0	-120	0	-190
80	120	0	-22	0	-35	0	-54	0	-87	0	-140	0	-220

2 Y-bearings

Table 13

Grub screws in inner rings and eccentric locking collars – key sizes and recommended tightening torques

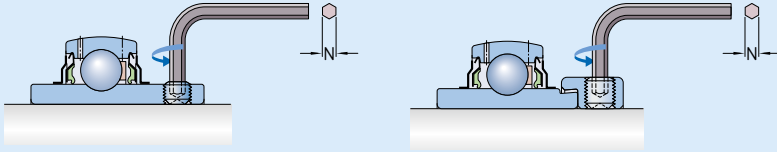

Bearing size ¹⁾	Bearing with metric bore		Bearing with inch bore		Bearing size ¹⁾	Bearing with metric bore		Bearing with inch bore	
	Hexagonal key size N	Tightening torque Nm	Hexagonal key size N	Tightening torque Nm		Hexagonal key size N	Tightening torque Nm	Hexagonal key size N	Tightening torque Nm
–	mm	Nm	in.	Nm	–	mm	Nm	in.	Nm
Bearings in the YAR 2 or YARAG 2 series					Bearings in the YAT 2 series				
03	3	4	3/32	4	03	3	4	3/32	4
04	3	4	1/8	4	04	3	4	1/8	4
05	3	4	1/8	4	05	3	4	1/8	4
06	3	4	1/8	4	06	3	4	5/32	6,5
07	3	4	5/32	6,5	07	3	4	5/32	6,5
08	4	6,5	5/32	6,5	08	3	4	5/32	6,5
09	4	6,5	5/32	6,5	09	3	4	5/32	6,5
10	5	16,5	3/16	16,5	10	4	6,5	5/32	6,5
11	5	16,5	3/16	16,5	11	–	–	3/16	16,5
12	5	16,5	3/16	16,5	12	–	–	3/16	16,5
13	5	16,5	3/16	16,5	15	–	–	3/16	16,5
14	5	16,5	7/32	28,5	16	–	–	3/16	16,5
15	5	16,5	7/32	28,5	Bearings in the YET 2, YEL 2 or YELAG 2 series				
16	5	16,5	7/32	28,5	03	3	4	1/8	4
17	6	28,5	–	–	04	3	4	1/8	4
18	6	28,5	–	–	05	3	4	1/8	4
20	6	28,5	–	–	06	4	6,5	5/32	6,5
					07	5	16,5	3/16	16,5
					08	5	16,5	3/16	16,5
					09	5	16,5	3/16	16,5
					10	5	16,5	3/16	16,5
					11	5	16,5	7/32	28,5
					12	5	16,5	7/32	28,5

¹⁾ For example: bearing size 06 includes all bearings based on a Y 206 bearing, such as YAR 206-101-2F, YAR 206-102-2F, YAR 206-2F, YAR 206-103-2F, YAR 206-104-2F

Table 14

Hook spanners for Y-bearings on an adapter sleeve – sizes and recommended tightening angles

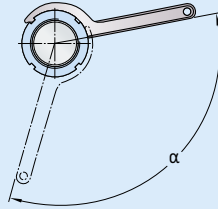

Designation Y-bearing + adapter sleeve	Shaft diameter		Hook spanner	Lock nut tightening angle ¹⁾ α
	mm	in.		
–	–	–	–	°
YSA 205-2FK + HE 2305	–	3/4	HN 5	90
YSA 205-2FK + H 2305	20	–	HN 5	90
YSA 206-2FK + HA 2306	–	15/16	HN 6	95
YSA 206-2FK + H 2306	25	–	HN 6	95
YSA 206-2FK + HE 2306	–	1	HN 6	95
YSA 207-2FK + H 2307	30	–	HN 7	100
YSA 207-2FK + HA 2307	–	1 3/16	HN 7	100
YSA 208-2FK + HE 2308	–	1 1/4	HN 8	105
YSA 208-2FK + H 2308	35	–	HN 8	105
YSA 209-2FK + HA 2309	–	1 7/16	HN 9	110
YSA 209-2FK + HE 2309	–	1 1/2	HN 9	110
YSA 209-2FK + H 2309	40	–	HN 9	110
YSA 210-2FK + HS 2310	–	1 5/8	HN 10	115
YSA 210-2FK + HA 2310	–	1 11/16	HN 10	115
YSA 210-2FK + HE 2310	–	1 3/4	HN 10	115
YSA 210-2FK + H 2310	45	–	HN 10	115
YSA 211-2FK + HA 2311 B	–	1 15/16	HN 11	90
YSA 211-2FK + H 2311	50	–	HN 11	90
YSA 211-2FK + HE 2311	–	2	HN 11	90
YSA 212-2FK + HS 2312	–	2 1/8	HN 12	95
YSA 212-2FK + H 2312	55	–	HN 12	95
YSA 213-2FK + HA 2313	–	2 3/16	HN 13	100
YSA 213-2FK + HE 2313	–	2 1/4	HN 13	100
YSA 213-2FK + H 2313	60	–	HN 13	100
YSA 213-2FK + HS 2313	–	2 3/8	HN 13	100

¹⁾ The listed values are to be used as guideline values only, as it is difficult to establish an exact starting position.

2 Y-bearings

Table 15

Grub screws in SKF ConCentra Y-bearings – key sizes and recommended tightening torques

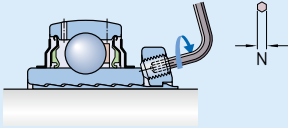

Bearing size ¹⁾		Screw size	Hexagonal key size N	Tightening torque
from	to			
–	–	–	mm	Nm
05	06	M5	2,5	4,2
07	13	M6	3	7,4

¹⁾ For example: bearing size 07 includes all bearings based on a Y 207 bearings such as YSP 207 SB-2F, YSP 207-104 SB-2F, YSP 207-106 SB-2F, YSP 207-107 SB-2F

Assembling Y-bearings into housings with fitting slots

When installing a Y-bearing into a housing with fitting slots, the bearing should be inserted into the fitting slot in the housing bore (→ fig. 33) and then swivelled into position.

When installing Y-bearings with two lubrication holes in the outer ring and the bearing has to be relubricated, make sure that one of the relubrication holes in the bearing coincides with the relubrication facility in the housing (→ fig 34, right). Be sure that the other relubrication hole is not aligned with either of the fitting slots, otherwise grease leakage may result (→ fig. 34, left).

Fig. 33

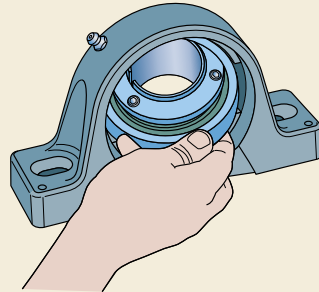
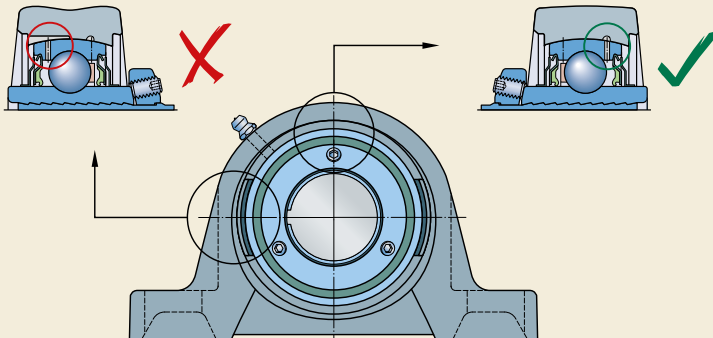

Fig. 34



Eccentric locking collars should be removed from the bearing prior to installation and reinstalled when the bearing is in position in the housing.

SKF recommends installing SKF Y-bearings only into SKF Y-housings to avoid a mismatch of components and to enable proper bearing relubrication.

SKF ConCentra Y-bearings

When mounting SKF ConCentra Y-bearings, position the collar so that one grub screw is directly opposite the slit in the sleeve.

CAUTION: Do not tighten the grub (set) screws until the bearing is positioned on the shaft. If the screws are tightened prematurely, the stepped sleeve may deform. No attempt should be made to disassemble the sleeve and the mounting collar from the bearing prior to installation.

To dismount SKF ConCentra Y-bearings loosen the grub screws first. Then gently tap the edge of the sleeve on the collar side, or the inner ring side face on the opposite side to loosen the lock (→ **fig. 35**).

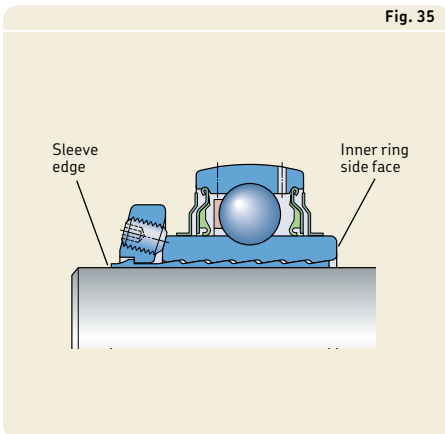

Designation system

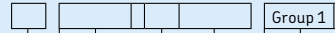

Prefixes

E2. SKF Energy Efficient bearing

Basic designation

Bearing design

- YAR** Bearing with grub screws, inner ring extended on both sides
- YARAG** Bearing with grub screws, inner ring extended on both sides, for agricultural applications
- YAT** Bearing with grub screws, inner ring extended on one side
- YEL** Bearing with an eccentric locking collar, inner ring extended on both sides
- YELAG** Bearing with an eccentric locking collar, inner ring extended on both sides, for agricultural applications
- YET** Bearing with an eccentric locking collar, inner ring extended on one side
- YSA** Bearing with a tapered bore, inner ring symmetrically extended on both sides
- YSP** Bearing with SKF ConCentra locking technology, inner ring symmetrically extended on both sides
- YSPAG** Bearing with SKF ConCentra locking technology, inner ring symmetrically extended on both sides, for agricultural applications
- 172** Bearing with a standard inner ring
- CYS** Bearing in the YET 2 series fitted with a rubber seating ring

Dimension series

- 2** Outside diameter to ISO 15, diameter series 2
- 62** Bearing in accordance with ISO 15, dimension series 02, sphered outside surface
- 63** Bearing in accordance with ISO 15, dimension series 03, sphered outside surface

Bore diameter d

- Bearings for metric shafts**
- 03/12** d = 12 mm
 - 03/15** d = 15 mm
 - 03** d = 17 mm
 - 04** d = 20 mm
 - to
 - 20** d = 100 mm

- Bearings for inch shafts**
- Three-digits combination that follows the designation of the basic metric bearing and is separated from this by a hyphen; the first digit is the number of whole inches and the second and third digits are the number of sixteenths of an inch, e.g. 204-012
- 008** d = 1/2 in. (12,7 mm)
 - to
 - 300** d = 3 in. (76,2 mm)

Suffixes

Group 1: Internal design

SB SKF ConCentra ball bearing with shortened inner ring

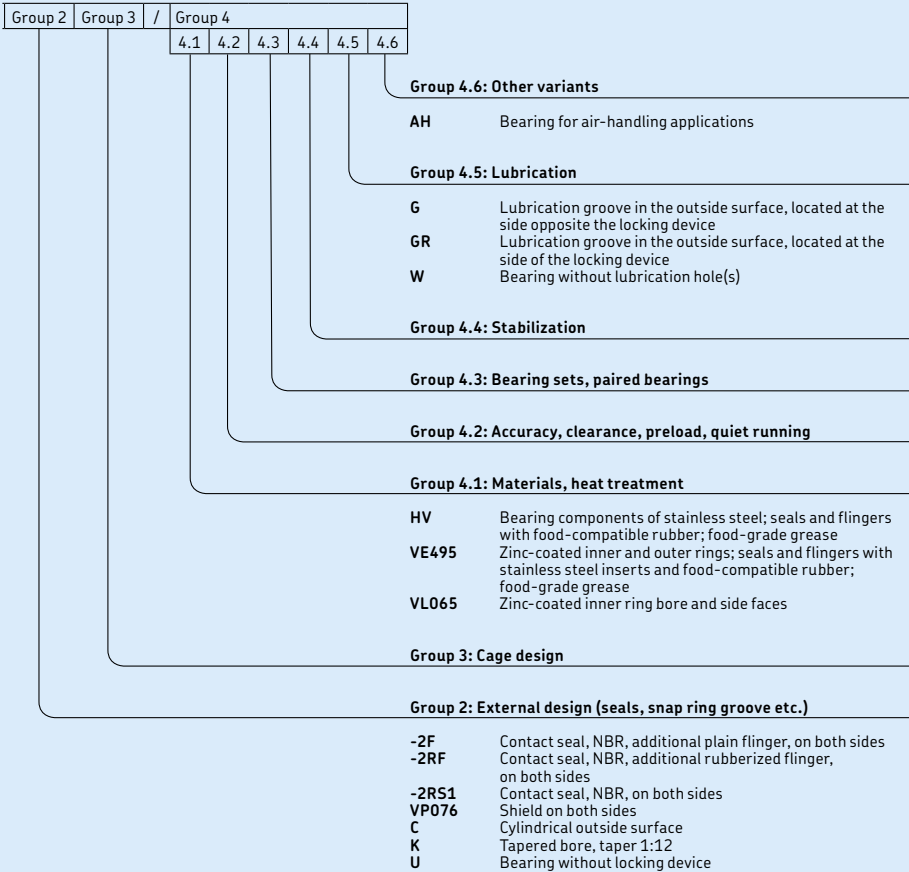

2.1 Y-bearings with grub screws, metric shafts d 12 – 100 mm

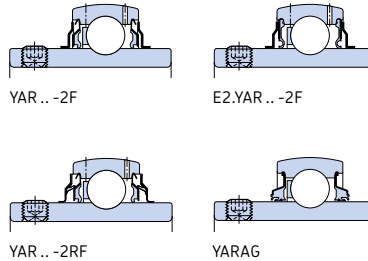
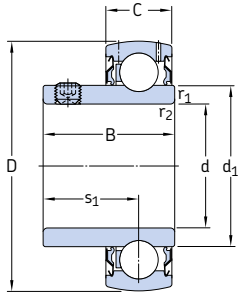

YAT

Dimensions							Basic load ratings		Fatigue load limit P_u	Limiting speed with shaft tolerance h6	Mass	Designation
d	D	B	C	d_1	s_1	$r_{1,2}$ min.	dynamic C	static C_0				
mm							kN		kN	r/min	kg	-
12	40	27,4	12	24,2	15,9	0,3	9,56	4,75	0,2	9 500	0,11	YAR 203/12-2F
15	40	27,4	12	24,2	15,9	0,3	9,56	4,75	0,2	9 500	0,1	YAR 203/15-2F
17	40	22,1	12	24,2	15,9	0,3	9,56	4,75	0,2	9 500	0,07	YAT 203
	40	27,4	12	24,2	15,9	0,3	9,56	4,75	0,2	9 500	0,09	YAR 203-2F
20	47	25,5	14	28,2	18,3	0,6	12,7	6,55	0,28	8 500	0,11	YAT 204
	47	31	14	28,2	18,3	0,6	12,7	6,55	0,28	8 500	0,14	E2.YAR 204-2F
	47	31	14	28,2	18,3	0,6	12,7	6,55	0,28	8 500	0,14	YAR 204-2F
	47	31	14	28,2	18,3	0,6	12,7	6,55	0,28	5 000	0,14	YAR 204-2RF
	47	31	14	28,2	18,3	0,6	10,8	6,55	0,28	5 000	0,14	YAR 204-2RF/HV
	47	31	14	28,2	18,3	0,6	12,7	6,55	0,28	5 000	0,14	YAR 204-2RF/VE495
25	47	31	14	28,2	18,3	0,6	12,7	6,55	0,28	1 800	0,15	YARAG 204
	52	27,2	15	33,7	19,5	0,6	14	7,8	0,335	7 000	0,14	YAT 205
	52	34,1	15	33,7	19,8	0,6	14	7,8	0,335	7 000	0,19	E2.YAR 205-2F
	52	34,1	15	33,7	19,8	0,6	14	7,8	0,335	7 000	0,17	YAR 205-2F
	52	34,1	15	33,7	19,8	0,6	14	7,8	0,335	4 300	0,17	YAR 205-2RF
	52	34,1	15	33,7	19,8	0,6	11,9	7,8	0,335	4 300	0,18	YAR 205-2RF/HV
30	52	34,1	15	33,7	19,8	0,6	14	7,8	0,335	4 300	0,18	YAR 205-2RF/VE495
	52	34,1	15	33,7	19,8	0,6	14	7,8	0,335	1 500	0,19	YARAG 205
	62	30,2	18	39,7	21	0,6	19,5	11,2	0,475	6 300	0,23	YAT 206
	62	38,1	18	39,7	22,2	0,6	19,5	11,2	0,475	6 300	0,3	E2.YAR 206-2F
	62	38,1	18	39,7	22,2	0,6	19,5	11,2	0,475	6 300	0,28	YAR 206-2F
	62	38,1	18	39,7	22,2	0,6	19,5	11,2	0,475	3 800	0,28	YAR 206-2RF
62	38,1	18	39,7	22,2	0,6	16,3	11,2	0,475	3 800	0,29	YAR 206-2RF/HV	
	38,1	18	39,7	22,2	0,6	19,5	11,2	0,475	3 800	0,29	YAR 206-2RF/VE495	
	38,1	18	39,7	22,2	0,6	19,5	11,2	0,475	1 200	0,3	YARAG 206	
	38,1	18	39,7	22,2	0,6	19,5	11,2	0,475	1 200	0,3	YARAG 206	

E2 → SKF Energy Efficient bearing

Dimensions							Basic load ratings		Fatigue load limit P_u	Limiting speed with shaft tolerance h6	Mass	Designation	
d	D	B	C	d_1	s_1	$r_{1,2}$	dynamic C	static C_0					
mm				~		min.	kN	kN	r/min	kg	-		
35	72	33	19	46,1	23,3	1	25,5	15,3	0,655	5 300	0,31	YAT 207	
	72	42,9	19	46,1	25,4	1	25,5	15,3	0,655	5 300	0,44	E2.YAR 207-2F	
	72	42,9	19	46,1	25,4	1	25,5	15,3	0,655	5 300	0,41	YAR 207-2F	
	72	42,9	19	46,1	25,4	1	25,5	15,3	0,655	3 200	0,41	YAR 207-2RF	
	72	42,9	19	46,1	25,4	1	21,6	15,3	0,655	3 200	0,42	YAR 207-2RF/HV	
	72	42,9	19	46,1	25,4	1	25,5	15,3	0,655	3 200	0,42	YAR 207-2RF/VE495	
	72	42,9	19	46,1	25,4	1	25,5	15,3	0,655	1 100	0,44	YARAG 207	
	40	80	36	21	51,8	25,3	1	30,7	19	0,8	4 800	0,43	YAT 208
		80	49,2	21	51,8	30,2	1	30,7	19	0,8	4 800	0,59	E2.YAR 208-2F
80		49,2	21	51,8	30,2	1	30,7	19	0,8	4 800	0,55	YAR 208-2F	
80		49,2	21	51,8	30,2	1	30,7	19	0,8	2 800	0,55	YAR 208-2RF	
80		49,2	21	51,8	30,2	1	26	19	0,8	2 800	0,56	YAR 208-2RF/HV	
80		49,2	21	51,8	30,2	1	30,7	19	0,8	2 800	0,56	YAR 208-2RF/VE495	
80		49,2	21	51,8	30,2	1	30,7	19	0,8	950	0,59	YARAG 208	
45		85	37	22	56,8	25,8	1	33,2	21,6	0,915	4 300	0,48	YAT 209
		85	49,2	22	56,8	30,2	1	33,2	21,6	0,915	4 300	0,65	E2.YAR 209-2F
	85	49,2	22	56,8	30,2	1	33,2	21,6	0,915	4 300	0,6	YAR 209-2F	
	85	49,2	22	56,8	30,2	1	33,2	21,6	0,915	2 400	0,6	YAR 209-2RF	
	85	49,2	22	56,8	30,2	1	33,2	21,6	0,915	850	0,66	YARAG 209	
50	90	38,8	22	62,5	27,6	1	35,1	23,2	0,98	4 000	0,54	YAT 210	
	90	51,6	22	62,5	32,6	1	35,1	23,2	0,98	4 000	0,69	YAR 210-2F	
	90	51,6	22	62,5	32,6	1	35,1	23,2	0,98	2 200	0,69	YAR 210-2RF	
	90	51,6	22	62,5	32,6	1	29,6	23,2	0,98	2 200	0,69	YAR 210-2RF/HV	
	90	51,6	22	62,5	32,6	1	35,1	23,2	0,98	2 200	0,69	YAR 210-2RF/VE495	
	90	51,6	22	62,5	32,6	1	35,1	23,2	0,98	800	0,74	YARAG 210	
55	100	55,6	25	69	33,4	1	43,6	29	1,25	3 600	0,94	YAR 211-2F	
	100	55,6	25	69	33,4	1	43,6	29	1,25	1 900	0,94	YAR 211-2RF	
60	110	65,1	26	75,6	39,7	1,5	52,7	36	1,53	3 400	1,35	YAR 212-2F	
	110	65,1	26	75,6	39,7	1,5	52,7	36	1,53	1 800	1,35	YAR 212-2RF	
65	120	68,3	27	82,5	42,9	1,5	57,2	40	1,7	3 000	1,7	YAR 213-2F	
	120	68,3	27	82,5	42,9	1,5	57,2	40	1,7	1 600	1,7	YAR 213-2RF	
70	125	69,9	28	87	39,7	1,5	62,4	45	1,86	2 800	1,9	YAR 214-2F	
75	130	73,3	29	92	46,3	1,5	66,3	49	2,04	2 600	2,1	YAR 215-2F	
80	140	77,8	30	97,4	47,6	2	72,8	53	2,16	2 400	2,7	YAR 216-2F	
85	150	81	34	105	50,8	2	83,2	62	2,4	2 200	3,35	YAR 217-2F	
90	160	89	36	112	54	2	95,6	72	2,7	2 000	4,1	YAR 218-2F	
100	180	98,4	40	124	63,4	2	124	93	3,35	1 900	5,35	YAR 220-2F	

2.2 Y-bearings with grub screws, inch shafts

d $1\frac{1}{2} - 1\frac{11}{16}$ in.

12,7 – 42,863 mm

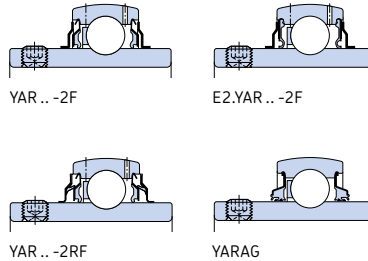
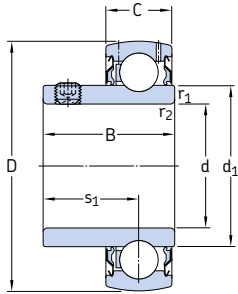

YAT

Principal dimensions							Basic load ratings		Fatigue load limit P_u	Limiting speed with shaft tolerance h6	Mass	Designation
d	D	B	C	d_1	s_1	$r_{1,2}$ min.	dynamic C	static C_0				
in./mm	mm			~			kN		kN	r/min	kg	-
$1\frac{1}{2}$ 12,7	40	27,4	12	24,2	15,9	0,3	9,56	4,75	0,2	9 500	0,12	YAR 203-008-2F
$5\frac{1}{8}$ 15,875	40	22,5	12	24,2	16	0,3	9,56	4,75	0,2	9 500	0,1	YAT 203-010
	40	27,4	12	24,2	15,9	0,3	9,56	4,75	0,2	9 500	0,11	YAR 203-010-2F
$3\frac{1}{4}$ 19,05	47	25,5	14	28,2	18,3	0,6	12,7	6,55	0,28	8 500	0,14	YAT 204-012
	47	31	14	28,2	18,3	0,6	12,7	6,55	0,28	8 500	0,14	E2.YAR 204-012-2F
	47	31	14	28,2	18,3	0,6	12,7	6,55	0,28	8 500	0,17	YAR 204-012-2F
	47	31	14	28,2	18,3	0,6	12,7	6,55	0,28	8 500	0,16	YAR 204-012-2F/AH
	47	31	14	28,2	18,3	0,6	12,7	6,55	0,28	5 000	0,16	YAR 204-012-2RF
	47	31	14	28,2	18,3	0,6	10,8	6,55	0,28	5 000	0,16	YAR 204-012-2RF/HV
	47	31	14	28,2	18,3	0,6	12,7	6,55	0,28	5 000	0,16	YAR 204-012-2RF/VE495
$7\frac{1}{8}$ 22,225	52	27,2	15	33,7	19,5	0,6	14	7,8	0,335	7 000	0,17	YAT 205-014
	52	34,1	15	33,7	19,8	0,6	14	7,8	0,335	7 000	0,21	E2.YAR 205-014-2F
$15\frac{1}{16}$ 23,813	52	27,2	15	33,7	19,5	0,6	14	7,8	0,335	7 000	0,18	YAT 205-015
	52	34,1	15	33,7	19,8	0,6	14	7,8	0,335	7 000	0,2	E2.YAR 205-015-2F
	52	34,1	15	33,7	19,8	0,6	14	7,8	0,335	7 000	0,21	YAR 205-015-2F
	52	34,1	15	33,7	19,8	0,6	14	7,8	0,335	4 300	0,21	YAR 205-015-2RF/VE495
1 25,4	52	27,2	15	33,7	19,5	0,6	14	7,8	0,335	7 000	0,16	YAT 205-100
	52	34,1	15	33,7	19,8	0,6	14	7,8	0,335	7 000	0,18	E2.YAR 205-100-2F
	52	34,1	15	33,7	19,8	0,6	14	7,8	0,335	7 000	0,19	YAR 205-100-2F
	52	34,1	15	33,7	19,8	0,6	14	7,8	0,335	7 000	0,19	YAR 205-100-2F/AH
	52	34,1	15	33,7	19,8	0,6	14	7,8	0,335	4 300	0,19	YAR 205-100-2RF
	52	34,1	15	33,7	19,8	0,6	11,9	7,8	0,335	4 300	0,19	YAR 205-100-2RF/HV
	52	34,1	15	33,7	19,8	0,6	14	7,8	0,335	4 300	0,19	YAR 205-100-2RF/VE495
	52	34,1	15	33,7	19,8	0,6	14	7,8	0,335	1 500	0,18	YARAG 205-100
$1\frac{1}{16}$ 26,988	62	38,1	18	39,7	22,2	0,6	19,5	11,2	0,475	6 300	0,34	E2.YAR 206-101-2F
	62	38,1	18	39,7	22,2	0,6	19,5	11,2	0,475	6 300	0,34	YAR 206-101-2F
$1\frac{1}{8}$ 28,575	62	38,1	18	39,7	22,2	0,6	19,5	11,2	0,475	6 300	0,32	E2.YAR 206-102-2F
	62	38,1	18	39,7	22,2	0,6	19,5	11,2	0,475	6 300	0,34	YAR 206-102-2F
	62	38,1	18	39,7	22,2	0,6	19,5	11,2	0,475	1 200	0,31	YARAG 206-102

E2 → SKF Energy Efficient bearing

Principal dimensions							Basic load ratings		Fatigue load limit P_u	Limiting speed with shaft tolerance h6	Mass kg	Designation
d	D	B	C	d_1	s_1	$r_{1,2}$ min.	dynamic C	static C_0				
in./mm	mm						kN	kN	r/min		-	
1³/₁₆ 30,163	62	31	18	39,7	22	0,6	19,5	11,2	0,475	6 300	0,28	YAT 206-103
	62	38,1	18	39,7	22,2	0,6	19,5	11,2	0,475	6 300	0,29	E2.YAR 206-103-2F
	62	38,1	18	39,7	22,2	0,6	19,5	11,2	0,475	6 300	0,31	YAR 206-103-2F
	62	38,1	18	39,7	22,2	0,6	19,5	11,2	0,475	6 300	0,31	YAR 206-103-2F/AH
	62	38,1	18	39,7	22,2	0,6	16,3	11,2	0,475	3 800	0,29	YAR 206-103-2RF/HV
	62	38,1	18	39,7	22,2	0,6	19,5	11,2	0,475	3 800	0,29	YAR 206-103-2RF/VE495
	62	38,1	18	39,7	22,2	0,6	19,5	11,2	0,475	1 200	0,29	YARAG 206-103
1¹/₄ 31,75	62	31	18	39,7	22	0,6	19,5	11,2	0,475	6 300	0,28	YAT 206-104
	62	38,1	18	39,7	22,2	0,6	19,5	11,2	0,475	6 300	0,27	E2.YAR 206-104-2F
	62	38,1	18	39,7	22,2	0,6	19,5	11,2	0,475	6 300	0,28	YAR 206-104-2F
	62	38,1	18	39,7	22,2	0,6	19,5	11,2	0,475	3 800	0,29	YAR 206-104-2RF/VE495
	62	38,1	18	39,7	22,2	0,6	19,5	11,2	0,475	1 200	0,27	YARAG 206-104
	72	42,9	19	46,1	25,4	1	25,5	15,3	0,655	5 300	0,5	E2.YAR 207-104-2F
	72	42,9	19	46,1	25,4	1	25,5	15,3	0,655	5 300	0,52	YAR 207-104-2F
	72	42,9	19	46,1	25,4	1	25,5	15,3	0,655	3 200	0,52	YAR 207-104-2RF
	72	42,9	19	46,1	25,4	1	21,6	15,3	0,655	3 200	0,52	YAR 207-104-2RF/HV
	72	42,9	19	46,1	25,4	1	25,5	15,3	0,655	3 200	0,52	YAR 207-104-2RF/VE495
	72	42,9	19	46,1	25,4	1	25,5	15,3	0,655	1 100	0,5	YARAG 207-104
1⁵/₁₆ 33,338	72	42,9	19	46,1	25,4	1	25,5	15,3	0,655	5 300	0,47	E2.YAR 207-105-2F
	72	42,9	19	46,1	25,4	1	25,5	15,3	0,655	5 300	0,48	YAR 207-105-2F
1³/₈ 34,925	72	42,9	19	46,1	25,4	1	25,5	15,3	0,655	5 300	0,44	E2.YAR 207-106-2F
	72	42,9	19	46,1	25,4	1	25,5	15,3	0,655	5 300	0,46	YAR 207-106-2F
	72	42,9	19	46,1	25,4	1	21,6	15,3	0,655	3 200	0,42	YAR 207-106-2RF/HV
	72	42,9	19	46,1	25,4	1	25,5	15,3	0,655	3 200	0,42	YAR 207-106-2RF/VE495
	72	42,9	19	46,1	25,4	1	25,5	15,3	0,655	1 100	0,44	YARAG 207-106
1⁷/₁₆ 36,513	72	35	19	46,1	25,5	1	25,5	15,3	0,655	5 300	0,38	YAT 207-107
	72	42,9	19	46,1	25,4	1	25,5	15,3	0,655	5 300	0,41	E2.YAR 207-107-2F
	72	42,9	19	46,1	25,4	1	25,5	15,3	0,655	5 300	0,42	YAR 207-107-2F
	72	42,9	19	46,1	25,4	1	21,6	15,3	0,655	3 200	0,43	YAR 207-107-2RF/HV
	72	42,9	19	46,1	25,4	1	25,5	15,3	0,655	3 200	0,43	YAR 207-107-2RF/VE495
	72	42,9	19	46,1	25,4	1	25,5	15,3	0,655	1 100	0,41	YARAG 207-107
	80	49,2	21	51,8	30,2	1	30,7	19	0,8	4 800	0,68	E2.YAR 208-107-2F
	80	49,2	21	51,8	30,2	1	30,7	19	0,8	4 800	0,7	YAR 208-107-2F
1¹/₂ 38,1	80	40	21	51,8	28,5	1	30,7	19	0,8	4 800	0,58	YAT 208-108
	80	49,2	21	51,8	30,2	1	30,7	19	0,8	4 800	0,64	E2.YAR 208-108-2F
	80	49,2	21	51,8	30,2	1	30,7	19	0,8	4 800	0,59	YAR 208-108-2F
	80	49,2	21	51,8	30,2	1	30,7	19	0,8	2 800	0,59	YAR 208-108-2RF
	80	49,2	21	51,8	30,2	1	26	19	0,8	2 800	0,56	YAR 208-108-2RF/HV
	80	49,2	21	51,8	30,2	1	30,7	19	0,8	2 800	0,59	YAR 208-108-2RF/VE495
	80	49,2	21	51,8	30,2	1	30,7	19	0,8	950	0,64	YARAG 208-108
	85	49,2	22	56,8	30,2	1	33,2	21,6	0,915	4 300	0,82	E2.YAR 209-108-2F
	85	49,2	22	56,8	30,2	1	33,2	21,6	0,915	4 300	0,86	YAR 209-108-2F
1⁹/₁₆ 39,688	80	49,2	21	51,8	30,2	1	30,7	19	0,8	4 800	0,6	E2.YAR 208-109-2F
	80	49,2	21	51,8	30,2	1	30,7	19	0,8	4 800	0,64	YAR 208-109-2F
1⁵/₈ 41,275	85	49,2	22	56,8	30,2	1	33,2	21,6	0,915	4 300	0,75	E2.YAR 209-110-2F
	85	49,2	22	56,8	30,2	1	33,2	21,6	0,915	4 300	0,79	YAR 209-110-2F
	85	49,2	22	56,8	30,2	1	33,2	21,6	0,915	850	0,79	YARAG 209-110
1¹¹/₁₆ 42,863	85	41,5	22	56,8	30,5	1	33,2	21,6	0,915	4 300	0,65	YAT 209-111
	85	49,2	22	56,8	30,2	1	33,2	21,6	0,915	4 300	0,71	E2.YAR 209-111-2F
	85	49,2	22	56,8	30,2	1	33,2	21,6	0,915	4 300	0,75	YAR 209-111-2F
	85	49,2	22	56,8	30,2	1	33,2	21,6	0,915	850	0,75	YARAG 209-111

E2 → SKF Energy Efficient bearing

2.2 Y-bearings with grub screws, inch shafts

d 1 3/4 – 3 in.

44,45 – 76,2 mm

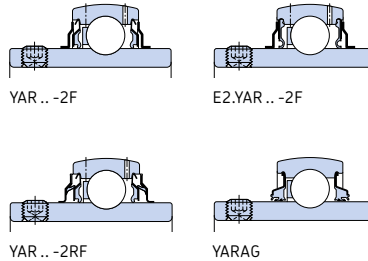
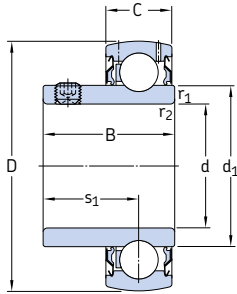

YAT

Principal dimensions							Basic load ratings		Fatigue load limit P_u	Limiting speed with shaft tolerance h6	Mass	Designation
d	D	B	C	d_1	s_1	$r_{1,2}$ min.	dynamic	static C_0				
in./mm		mm				kN		kN	r/min	kg	-	
1 3/4 44,45	85	41,5	22	56,8	30,5	1	33,2	21,6	0,915	4 300	0,6	YAT 209-112
	85	49,2	22	56,8	30,2	1	33,2	21,6	0,915	4 300	0,67	E2.YAR 209-112-2F
	85	49,2	22	56,8	30,2	1	33,2	21,6	0,915	4 300	0,62	YAR 209-112-2F
	85	49,2	22	56,8	30,2	1	33,2	21,6	0,915	2 400	0,62	YAR 209-112-2RF
1 15/16 49,213	90	43	22	62,5	32	1	35,1	23,2	0,98	4 000	0,67	YAT 210-115
	90	51,6	22	62,5	32,6	1	35,1	23,2	0,98	4 000	0,78	YAR 210-115-2F
	90	51,6	22	62,5	32,6	1	35,1	23,2	0,98	2 200	0,78	YAR 210-115-2RF
	90	51,6	22	62,5	32,6	1	29,6	23,2	0,98	2 200	0,78	YAR 210-115-2RF/HV
	90	51,6	22	62,5	32,6	1	35,1	23,2	0,98	2 200	0,78	YAR 210-115-2RF/VE495
	90	51,6	22	62,5	32,6	1	35,1	23,2	0,98	800	0,77	YARAG 210-115
2 50,8	100	45	25	69	32,5	1	43,6	29	1,25	3 600	1,05	YAT 211-200
	100	55,6	25	69	33,4	1	43,6	29	1,25	3 600	1,1	YAR 211-200-2F
	100	55,6	25	69	33,4	1	43,6	29	1,25	1 900	1,1	YAR 211-200-2RF
2 3/16 55,563	100	55,6	25	69	33,4	1	43,6	29	1,25	3 600	1,05	YAR 211-203-2F
	100	55,6	25	69	33,4	1	43,6	29	1,25	3 600	1,05	YAR 211-203-2F/AH
	110	65,1	26	75,6	39,7	1,5	52,7	36	1,53	3 400	1,7	YAR 212-203-2F
2 1/4 57,15	110	48,5	26	75,6	35	1,5	52,7	36	1,53	3 400	1,25	YAT 212-204
	110	65,1	26	75,6	39,7	1,5	52,7	36	1,53	3 400	1,6	YAR 212-204-2F
2 7/16 61,913	110	48,5	26	75,6	35	1,5	52,7	36	1,53	3 400	1,25	YAT 212-207
	110	65,1	26	75,6	39,7	1,5	52,7	36	1,53	3 400	1,35	YAR 212-207-2F
	125	69,9	28	87	39,7	1,5	62,4	44	1,86	2 800	2,45	YAR 214-207-2F
2 1/2 63,5	120	68,3	27	82,5	42,9	1,5	57,2	40	1,7	3 000	1,9	YAR 213-208-2F
	120	68,3	27	82,5	42,9	1,5	57,2	40	1,7	1 600	1,9	YAR 213-208-2RF
	125	69,9	28	87	39,7	1,5	62,4	44	1,86	2 800	2,4	YAR 214-208-2F
2 11/16 68,263	120	68,3	27	82,5	42,9	1,5	57,2	40	1,7	3 000	1,7	YAR 213-211-2F
2 15/16 74,613	130	53,5	29	92	39	1,5	66,3	49	2,04	2 600	2,1	YAT 215-215
	130	73,3	29	92	46,1	1,5	66,3	49	2,04	2 600	2,2	YAR 215-215-2F
3 76,2	140	55,5	30	97,4	39	2	72,8	53	2,16	2 400	2,35	YAT 216-300
	140	77,9	30	97,4	47,7	2	72,8	53	2,16	2 400	2,85	YAR 216-300-2F

E2 → SKF Energy Efficient bearing

2.3 Y-bearings with an eccentric locking collar, metric shafts d 15 – 60 mm

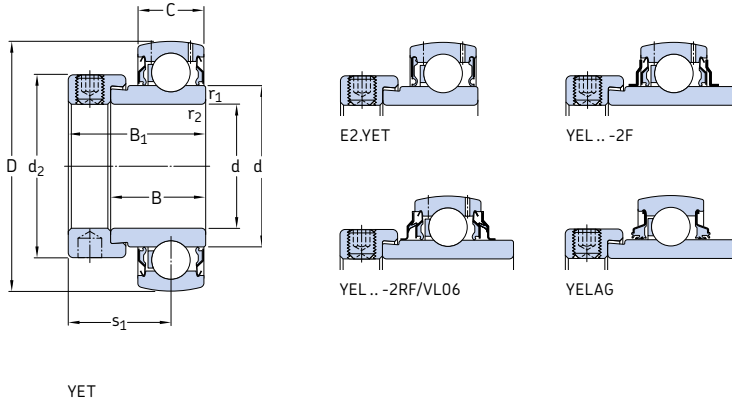

Dimensions								Basic load ratings		Fatigue load limit	Limiting speed with shaft tolerance h6	Mass	Designation		
d	D	B	B ₁	C	d ₁	d ₂	s ₁	r _{1,2} min.	C	C ₀	P _u	r/min	kg	-	
mm											kN	kN	r/min	kg	-
15	40	19,1	28,6	12	24,2	27,2	22,6	0,3	9,56	4,75	0,2	9 500	0,12	YET 203/15	
17	40	19,1	28,6	12	24,2	27,2	22,6	0,3	9,56	4,75	0,2	9 500	0,1	YET 203	
20	47	21,5	31	14	28,2	32,4	24	0,6	12,7	6,55	0,28	8 500	0,16	E2.YET 204	
	47	21,5	31	14	28,2	32,4	24	0,6	12,7	6,55	0,28	8 500	0,18	YET 204	
	47	21,5	31	14	28,2	32,4	24	0,6	12,7	6,55	0,28	8 500	0,18	YET 204/VL065	
	47	34,2	43,7	14	28,2	32,4	26,6	0,6	12,7	6,55	0,28	8 500	0,19	YEL 204-2F	
	47	34,2	43,7	14	28,2	32,4	26,6	0,6	12,7	6,55	0,28	5 000	0,19	YEL 204-2RF/VL065	
	47	34,2	43,7	14	28,2	32,4	26,6	0,6	12,7	6,55	0,28	1 800	0,19	YELAG 204	
25	52	21,5	31	15	33,7	37,4	23,5	0,6	14	7,8	0,335	7 000	0,19	E2.YET 205	
	52	21,5	31	15	33,7	37,4	23,5	0,6	14	7,8	0,335	7 000	0,18	YET 205	
	52	21,5	31	15	33,7	37,4	23,5	0,6	14	7,8	0,335	7 000	0,18	YET 205/VL065	
	52	34,9	44,4	15	33,7	37,4	26,9	0,6	14	7,8	0,335	7 000	0,24	YEL 205-2F	
	52	34,9	44,4	15	33,7	37,4	26,9	0,6	14	7,8	0,335	4 300	0,24	YEL 205-2RF/VL065	
	52	34,9	44,4	15	33,7	37,4	26,9	0,6	14	7,8	0,335	1 500	0,23	YELAG 205	
30	62	23,8	35,7	18	39,7	44,1	26,7	0,6	19,5	11,2	0,475	6 300	0,3	E2.YET 206	
	62	23,8	35,7	18	39,7	44,1	26,7	0,6	19,5	11,2	0,475	6 300	0,3	YET 206	
	62	23,8	35,7	18	39,7	44,1	26,7	0,6	19,5	11,2	0,475	6 300	0,3	YET 206/VL065	
	62	36,5	48,4	18	39,7	44,1	30,1	0,6	19,5	11,2	0,475	6 300	0,36	YEL 206-2F	
	62	36,5	48,4	18	39,7	44,1	30,1	0,6	19,5	11,2	0,475	3 900	0,36	YEL 206-2RF/VL065	
	62	36,5	48,4	18	39,7	44,1	30,1	0,6	19,5	11,2	0,475	1 200	0,36	YELAG 206	
35	72	25,4	38,9	19	46,1	51,1	29,4	1	25,5	15,3	0,655	5 300	0,44	E2.YET 207	
	72	25,4	38,9	19	46,1	51,1	29,4	1	25,5	15,3	0,655	5 300	0,44	YET 207	
	72	25,4	38,9	19	46,1	51,1	29,4	1	25,5	15,3	0,655	5 300	0,44	YET 207/VL065	
	72	37,6	51,1	19	46,1	51,1	32,3	1	25,5	15,3	0,655	5 300	0,55	YEL 207-2F	
	72	37,6	51,1	19	46,1	51,1	32,3	1	25,5	15,3	0,655	3 200	0,55	YEL 207-2RF/VL065	
	72	37,6	51,1	19	46,1	51,1	32,3	1	25,5	15,3	0,655	1 100	0,52	YELAG 207	

Dimensions										Basic load ratings dynamic C	static C ₀	Fatigue load limit P _u	Limiting speed with shaft tolerance h6	Mass kg	Designation
d	D	B	B ₁	C	d ₁ ~	d ₂	s ₁	r _{1,2} min.	r _{1,2} min.						
mm										kN	kN	r/min	kg	-	
40	80	30,2	43,7	21	51,8	56,5	33,2	1	30,7	19	0,8	4 800	0,6	E2.YET 208	
	80	30,2	43,7	21	51,8	56,5	33,2	1	30,7	19	0,8	4 800	0,59	YET 208	
	80	30,2	43,7	21	51,8	56,5	33,2	1	30,7	19	0,8	4 800	0,59	YET 208/VL065	
	80	42,8	56,3	21	51,8	56,5	34,9	1	30,7	19	0,8	4 800	0,67	YEL 208-2F	
	80	42,8	56,3	21	51,8	56,5	34,9	1	30,7	19	0,8	2 800	0,67	YEL 208-2RF/VL065	
	80	42,8	56,3	21	51,8	56,5	34,9	1	30,7	19	0,8	950	0,7	YELAG 208	
45	85	30,2	43,7	22	56,8	62	32,7	1	33,2	21,6	0,915	4 300	0,66	E2.YET 209	
	85	30,2	43,7	22	56,8	62	32,7	1	33,2	21,6	0,915	4 300	0,65	YET 209	
	85	42,8	56,3	22	56,8	62	34,9	1	33,2	21,6	0,915	4 300	0,74	YEL 209-2F	
	85	42,8	56,3	22	56,8	62	34,9	1	33,2	21,6	0,915	850	0,78	YELAG 209	
50	90	30,2	43,7	22	62,5	67,2	32,7	1	35,1	23,2	0,98	4 000	0,7	YET 210	
	90	49,2	62,7	22	62,5	67,2	38,1	1	35,1	23,2	0,98	4 000	0,89	YEL 210-2F	
	90	49,2	62,7	22	62,5	67,2	38,1	1	35,1	23,2	0,98	800	0,87	YELAG 210	
55	100	32,6	48,4	25	69	74,5	35,9	1	43,6	29	1,25	3 600	0,9	YET 211	
	100	55,6	71,4	25	69	74,5	43,6	1	43,6	29	1,25	3 600	1,2	YEL 211-2F	
60	110	37,2	53,1	26	75,6	82	40,1	1,5	52,7	36	1,53	3 400	1,3	YET 212	
	110	61,9	77,8	26	75,6	82	46,8	1,5	52,7	36	1,53	3 400	1,6	YEL 212-2F	

2.4 Y-bearings with an eccentric locking collar, inch shafts

d 1/2 – 2 7/16 in.

12,7 – 61,913 mm

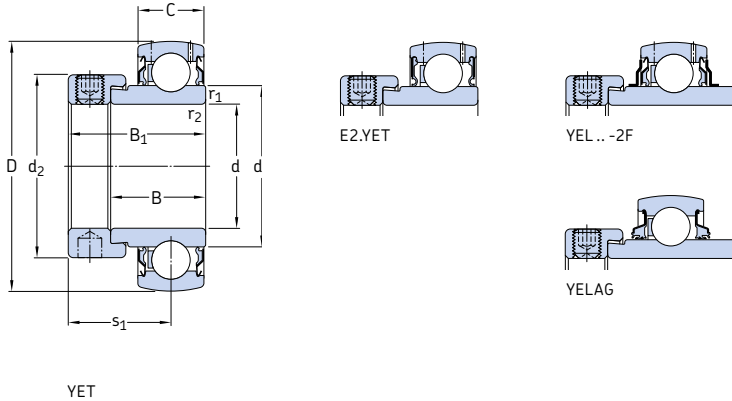

Dimensions										Basic load ratings		Fatigue load limit	Limiting speed with shaft tolerance h6	Mass	Designation
d	D	B	B ₁	C	d ₁	d ₂	s ₁	r _{1,2} min.	dynamic C	static C ₀	P _u	r/min	kg	-	
in./mm	mm								kN	kN	kN	r/min	kg	-	
1/2 12,7	40	19,1	28,6	12	24,2	27,2	22,6	0,3	9,56	4,75	0,2	9 500	0,13	YET 203-008	
3/4 19,05	47	21,5	31	14	28,2	32,4	24	0,6	12,7	6,55	0,28	8 500	0,16	E2.YET 204-012	
	47	21,5	31	14	28,2	32,4	24	0,6	12,7	6,55	0,28	8 500	0,17	YET 204-012	
	47	34,2	43,7	14	28,2	32,4	26,6	0,6	12,7	6,55	0,28	8 500	0,2	YEL 204-012-2F	
1 25,4	52	21,5	31	15	33,7	37,4	23,5	0,6	14	7,8	0,335	7 000	0,18	E2.YET 205-100	
	52	21,5	31	15	33,7	37,4	23,5	0,6	14	7,8	0,335	7 000	0,18	YET 205-100	
	52	34,9	44,4	15	33,7	37,4	26,9	0,6	14	7,8	0,335	7 000	0,22	YEL 205-100-2F	
	52	34,9	44,4	15	33,7	37,4	26,9	0,6	14	7,8	0,335	1 500	0,23	YELAG 205-100	
1 1/8 28,575	62	23,8	35,7	18	39,7	44,1	26,7	0,6	19,5	11,2	0,475	6 300	0,32	E2.YET 206-102	
	62	23,8	35,7	18	39,7	44,1	26,7	0,6	19,5	11,2	0,475	6 300	0,32	YET 206-102	
	62	36,5	48,4	18	39,7	44,1	30,1	0,6	19,5	11,2	0,475	6 300	0,39	YEL 206-102-2F	
	62	36,5	48,4	18	39,7	44,1	30,1	0,6	19,5	11,2	0,475	1 200	0,39	YELAG 206-102	
1 3/16 30,163	62	23,8	35,7	18	39,7	44,1	26,7	0,6	19,5	11,2	0,475	6 300	0,3	E2.YET 206-103	
	62	23,8	35,7	18	39,7	44,1	26,7	0,6	19,5	11,2	0,475	6 300	0,3	YET 206-103	
	62	36,5	48,4	18	39,7	44,1	30,1	0,6	19,5	11,2	0,475	6 300	0,35	YEL 206-103-2F	
	62	36,5	48,4	18	39,7	44,1	30,1	0,6	19,5	11,2	0,475	1 200	0,36	YELAG 206-103	
1 1/4 31,75	62	23,8	35,7	18	39,7	44,1	26,7	0,6	19,5	11,2	0,475	6 300	0,27	E2.YET 206-104	
	62	23,8	35,7	18	39,7	44,1	26,7	0,6	19,5	11,2	0,475	6 300	0,28	YET 206-104	
	72	25,4	38,9	19	46,1	51,1	29,4	1	25,5	15,3	0,655	5 300	0,48	E2.YET 207-104	
	72	25,4	38,9	19	46,1	51,1	29,4	1	25,5	15,3	0,655	5 300	0,49	YET 207-104	
	72	37,6	51,1	19	46,1	51,1	32,3	1	25,5	15,3	0,655	5 300	0,57	YEL 207-104-2F	
	72	37,6	51,1	19	46,1	51,1	32,3	1	25,5	15,3	0,655	1 100	0,59	YELAG 207-104	
1 5/16 33,338	72	25,4	38,9	19	46,1	51,1	29,4	1	25,5	15,3	0,655	5 300	0,46	YET 207-105	
1 3/8 34,925	72	25,4	38,9	19	46,1	51,1	29,4	1	25,5	15,3	0,655	5 300	0,43	E2.YET 207-106	
	72	25,4	38,9	19	46,1	51,1	29,4	1	25,5	15,3	0,655	5 300	0,44	YET 207-106	
	72	37,6	51,1	19	46,1	51,1	32,3	1	25,5	15,3	0,655	5 300	0,5	YEL 207-106-2F	
	72	37,6	51,1	19	46,1	51,1	32,3	1	25,5	15,3	0,655	1 100	0,52	YELAG 207-106	

E2 → SKF Energy Efficient bearing

Dimensions										Basic load ratings		Fatigue load limit P_u	Limiting speed with shaft tolerance h_6	Mass	Designation	
d	D	B	B_1	C	d_1	d_2	s_1	$r_{1,2}$	$r_{1,2}$ min.	dynamic C	static C_0					kN
in./mm	mm															
17/16 36,513	72	25,4	38,9	19	46,1	51,1	29,4	1	25,5	15,3	0,655	5 300	0,4	E2.YET 207-107		
	72	25,4	38,9	19	46,1	51,1	29,4	1	25,5	15,3	0,655	5 300	0,44	YET 207-107		
	72	37,6	51,1	19	46,1	51,1	32,3	1	25,5	15,3	0,655	5 300	0,53	YEL 207-107-2F		
	72	37,6	51,1	19	46,1	51,1	32,3	1	25,5	15,3	0,655	1 100	0,44	YELAG 207-107		
11/2 38,1	80	30,2	43,7	21	51,8	56,5	33,2	1	30,7	19	0,8	4 800	0,62	E2.YET 208-108		
	80	30,2	43,7	21	51,8	56,5	33,2	1	30,7	19	0,8	4 800	0,63	YET 208-108		
	80	42,8	56,3	21	51,8	56,5	34,9	1	30,7	19	0,8	4 800	0,77	YEL 208-108-2F		
	80	42,8	56,3	21	51,8	56,5	34,9	1	30,7	19	0,8	950	0,77	YELAG 208-108		
111/16 42,863	85	30,2	43,7	22	56,8	62	32,7	1	33,2	21,6	0,915	4 300	0,69	E2.YET 209-111		
	85	30,2	43,7	22	56,8	62	32,7	1	33,2	21,6	0,915	4 300	0,74	YET 209-111		
	85	42,8	56,3	22	56,8	62	34,9	1	33,2	21,6	0,915	4 300	0,88	YEL 209-111-2F		
	85	42,8	56,3	22	56,8	62	34,9	1	33,2	21,6	0,915	850	0,84	YELAG 209-111		
13/4 44,45	85	30,2	43,7	22	56,8	62	32,7	1	33,2	21,6	0,915	4 300	0,65	E2.YET 209-112		
	85	30,2	43,7	22	56,8	62	32,7	1	33,2	21,6	0,915	4 300	0,7	YET 209-112		
	85	42,8	56,3	22	56,8	62	34,9	1	33,2	21,6	0,915	4 300	0,8	YEL 209-112-2F		
	85	42,8	56,3	22	56,8	62	34,9	1	33,2	21,6	0,915	850	0,79	YELAG 209-112		
115/16 49,213	90	49,2	62,7	22	62,5	67,2	38,1	1	35,1	23,2	0,98	4 000	0,94	YEL 210-115-2F		
	90	49,2	62,7	22	62,5	67,2	38,1	1	35,1	23,2	0,98	800	0,92	YELAG 210-115		
2 50,8	100	55,6	71,4	25	69	74,5	43,6	1	43,6	29	1,25	3 600	1,5	YEL 211-200-2F		
23/16 55,563	100	55,6	71,4	25	69	74,5	43,6	1	43,6	29	1,25	3 600	1,3	YEL 211-203-2F		
27/16 61,913	110	37,2	53,1	26	75,6	82	40,1	1,5	52,7	36	1,53	3 400	1,2	YET 212-207		
	110	61,9	77,8	26	75,6	82	46,8	1,5	52,7	36	1,53	3 400	1,7	YEL 212-207-2F		

2.5 SKF ConCentra Y-bearings, metric shafts d 25 – 60 mm

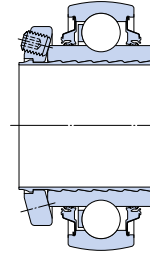
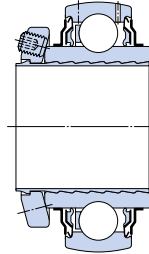
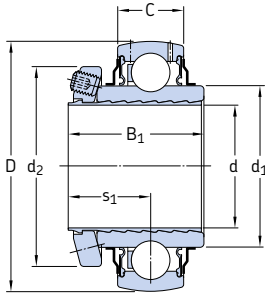

E2.YSP..SB-2F

YSP..SB-2F

YSPAG

Dimensions								Basic load ratings		Fatigue load limit P_u	Limiting speed	Mass	Designation
d	D	$B_1^{1)}$	C	d_1	d_2	$s_1^{1)}$	C	C_0					
mm								kN		kN	r/min	kg	-
25	52	33	15	33,7	41,7	21	14	7,8	0,335	7 000	0,18	E2.YSP 205 SB-2F	
	52	33	15	33,7	41,7	21	14	7,8	0,335	7 000	0,19	YSP 205 SB-2F	
	52	33	15	33,7	41,7	21	14	7,8	0,335	1 500	0,19	YSPAG 205	
30	62	37	18	39,7	48	23	19,5	11,2	0,475	6 300	0,3	E2.YSP 206 SB-2F	
	62	37	18	39,7	48	23	19,5	11,2	0,475	6 300	0,3	YSP 206 SB-2F	
	62	37	18	39,7	48	23	19,5	11,2	0,475	1 200	0,3	YSPAG 206	
35	72	39,5	19	46,1	57	24,3	25,5	15,3	0,655	5 300	0,44	E2.YSP 207 SB-2F	
	72	39,5	19	46,1	57	24,3	25,5	15,3	0,655	5 300	0,45	YSP 207 SB-2F	
	72	39,5	19	46,1	57	24,3	25,5	15,3	0,655	1 100	0,44	YSPAG 207	
40	80	42,9	21	51,8	62	25,9	30,7	19	0,8	4 800	0,59	E2.YSP 208 SB-2F	
	80	42,9	21	51,8	62	25,9	30,7	19	0,8	4 800	0,6	YSP 208 SB-2F	
	80	42,9	21	51,8	62	25,9	30,7	19	0,8	950	0,59	YSPAG 208	
45	85	44	22	56,8	67	26,5	33,2	21,6	0,915	4 300	0,64	E2.YSP 209 SB-2F	
	85	44	22	56,8	67	26,5	33,2	21,6	0,915	4 300	0,65	YSP 209 SB-2F	
	85	44	22	56,8	67	26,5	33,2	21,6	0,915	850	0,64	YSPAG 209	
50	90	46	22	62,5	72	27,5	35,1	23,2	0,98	4 000	0,75	YSP 210 SB-2F	
	90	46	22	62,5	72	27,5	35,1	23,2	0,98	800	0,74	YSPAG 210	
55	100	49	25	69	77,6	29	43,6	29	1,25	3 600	0,98	YSP 211 SB-2F	
60	110	51,5	26	75,6	83	30,3	52,7	36	1,53	3 400	1,25	YSP 212 SB-2F	

¹⁾ Width/distance before the grub screw is tightened (sleeve and inner ring bore at starting position).
E2 → SKF Energy Efficient bearing

2.6 SKF ConCentra Y-bearings, inch shafts

d 1 – 2 11/16 in.

25,4 – 68,263 mm

2.5
2.6

Dimensions							Basic load ratings		Fatigue load limit	Limiting speed	Mass	Designation
d	D	B ₁ ¹⁾	C	d ₁	d ₂	s ₁ ¹⁾	dynamic C	static C ₀	P _u	r/min	kg	
in./mm	mm						kN		kN			–
1 25,4	52	33	15	33,7	41,7	21	14	7,8	0,335	7 000	0,18	E2.YSP 205-100 SB-2F
	52	33	15	33,7	41,7	21	14	7,8	0,335	7 000	0,18	YSP 205-100 SB-2F
	52	33	15	33,7	41,7	21	14	7,8	0,335	1 500	0,18	YSPAG 205-100
1 3/16 30,163	62	37	18	39,7	48	23	19,5	11,2	0,475	6 300	0,29	E2.YSP 206-103 SB-2F
	62	37	18	39,7	48	23	19,5	11,2	0,475	6 300	0,3	YSP 206-103 SB-2F
	62	37	18	39,7	48	23	19,5	11,2	0,475	1 200	0,29	YSPAG 206-103
1 1/4 31,75	72	39,5	19	46,1	57	24,3	25,5	15,3	0,655	5 300	0,49	E2.YSP 207-104 SB-2F
	72	39,5	19	46,1	57	24,3	25,5	15,3	0,655	5 300	0,52	YSP 207-104 SB-2F
	72	39,5	19	46,1	57	24,3	25,5	15,3	0,655	1 100	0,49	YSPAG 207-104
1 3/8 34,925	72	39,5	19	46,1	57	24,3	25,5	15,3	0,655	5 300	0,44	E2.YSP 207-106 SB-2F
	72	39,5	19	46,1	57	24,3	25,5	15,3	0,655	5 300	0,44	YSP 207-106 SB-2F
	72	39,5	19	46,1	57	24,3	25,5	15,3	0,655	1 100	0,44	YSPAG 207-106
1 7/16 36,513	72	39,5	19	46,1	57	24,3	25,5	15,3	0,655	5 300	0,41	E2.YSP 207-107 SB-2F
	72	39,5	19	46,1	57	24,3	25,5	15,3	0,655	5 300	0,42	YSP 207-107 SB-2F
	72	39,5	19	46,1	57	24,3	25,5	15,3	0,655	1 100	0,41	YSPAG 207-107
1 1/2 38,1	80	42,9	21	51,8	62	25,9	30,7	19	0,8	4 800	0,58	E2.YSP 208-108 SB-2F
	80	42,9	21	51,8	62	25,9	30,7	19	0,8	4 800	0,59	YSP 208-108 SB-2F
	80	42,9	21	51,8	62	25,9	30,7	19	0,8	950	0,58	YSPAG 208-108
1 11/16 42,863	85	44	22	56,8	67	26,5	33,2	21,6	0,915	4 300	0,69	E2.YSP 209-111 SB-2F
	85	44	22	56,8	67	26,5	33,2	21,6	0,915	4 300	0,7	YSP 209-111 SB-2F
	85	44	22	56,8	67	26,5	33,2	21,6	0,915	850	0,69	YSPAG 209-111
1 15/16 49,213	90	46	22	62,5	72	27,5	35,1	23,2	0,98	4 000	0,75	YSP 210-115 SB-2F
	90	46	22	62,5	72	27,5	35,1	23,2	0,98	800	0,74	YSPAG 210-115
2 50,8	100	49	25	69	77,6	29	43,6	29	1,25	3 600	1,1	YSP 211-200 SB-2F
	100	49	25	69	77,6	29	43,6	29	1,25	3 600	0,97	YSP 211-203 SB-2F
2 3/16 55,563	110	51,5	26	75,6	83	30,3	52,7	36	1,53	3 400	1,35	YSP 212-204 SB-2F
	110	51,5	26	75,6	87,3	30,3	52,7	36	1,53	3 400	1,2	YSP 212-207 SB-2F
2 7/16 61,913	120	52,5	27	82,5	89,4	30,8	57,2	40	1,7	3 000	1,45	YSP 213-211 SB-2F
	120	52,5	27	82,5	89,4	30,8	57,2	40	1,7	3 000	1,45	YSP 213-211 SB-2F

¹⁾ Width/distance before the grub screw is tightened (sleeve and inner ring bore at starting position).

E2 → SKF Energy Efficient bearing

2.7 Y-bearings with a tapered bore on an adapter sleeve, metric shafts d 20 – 60 mm

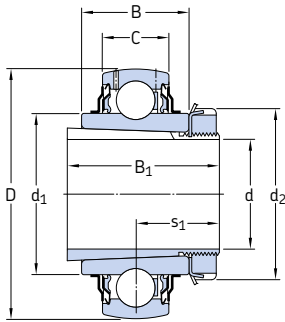

Dimensions								Basic load ratings		Fatigue load limit	Limiting speed	Mass Bearing incl. sleeve	Designations Bearing	Adapter sleeve
d	D	B	B ₁	C	d ₁	d ₂	s ₁ ¹⁾	dynamic C	static C ₀	P _u	r/min	kg	-	
mm								kN		kN				
20	52	24	35	15	33,7	38	20,5	14	7,8	0,335	7 000	0,22	YSA 205-2FK	H 2305
25	62	28	38	18	39,7	45	22,5	19,5	11,2	0,475	6 300	0,33	YSA 206-2FK	H 2306
30	72	30,5	43	19	46,1	52	24,8	25,5	15,3	0,655	5 300	0,47	YSA 207-2FK	H 2307
35	80	33,9	46	21	51,8	58	27,5	30,7	19	0,8	4 800	0,69	YSA 208-2FK	H 2308
40	85	35	50	22	56,8	65	29	33,2	21,6	0,915	4 300	0,77	YSA 209-2FK	H 2309
45	90	37	55	22	62,5	70	31,1	35,1	23,2	0,98	4 000	0,88	YSA 210-2FK	H 2310
50	100	40	59	25	69	75	32,5	43,6	29	1,25	3 600	1,1	YSA 211-2FK	H 2311
55	110	42,5	62	26	75,6	80	33,8	52,7	36	1,53	3 400	1,4	YSA 212-2FK	H 2312
60	120	43,5	65	27	82,5	85	35,4	57,2	40	1,7	3 000	1,7	YSA 213-2FK	H 2313

¹⁾ Distance before the sleeve is driven into the bearing bore (sleeve and inner ring bore at starting position).

2.8 Y-bearings with a tapered bore on an adapter sleeve, inch shafts

d $\frac{3}{4}$ – $2\frac{3}{8}$ in.

19,05 – 60,325 mm

2.7
2.8

Dimensions									Basic load ratings dynamic C	static C ₀	Fatigue load limit P _u	Limiting speed	Mass Bearing incl. sleeve	Designations Bearing	Adapter sleeve
d	D	B	B ₁	C	d ₁	d ₂	s ₁ ¹⁾								
in./mm	mm							kN	kN	r/min	kg	–			
$\frac{3}{4}$ 19,05	52	24	35	15	33,7	38	20,5	14	7,8	0,335	7 000	0,22	YSA 205-2FK	HE 2305	
$\frac{15}{16}$ 23,813	62	28	38	18	39,7	45	22,5	19,5	11,2	0,475	6 300	0,35	YSA 206-2FK	HA 2306	
1 25,4	62	28	38	18	39,7	45	22,5	19,5	11,2	0,475	6 300	0,33	YSA 206-2FK	HE 2306	
$1\frac{1}{16}$ 30,163	72	30,5	43	19	46,1	52	24,8	25,5	15,3	0,655	5 300	0,47	YSA 207-2FK	HA 2307	
$1\frac{1}{4}$ 31,75	80	33,9	46	21	51,8	58	27,5	30,7	19	0,8	4 800	0,69	YSA 208-2FK	HE 2308	
$1\frac{7}{16}$ 36,513	85	35	50	22	56,8	65	29	33,2	21,6	0,915	4 300	0,81	YSA 209-2FK	HA 2309	
$1\frac{1}{2}$ 38,1	85	35	50	22	56,8	65	29	33,2	21,6	0,915	4 300	0,77	YSA 209-2FK	HE 2309	
$1\frac{5}{8}$ 41,275	90	37	55	22	62,5	70	31,1	35,1	23,2	0,98	4 000	0,94	YSA 210-2FK	HS 2310	
$1\frac{11}{16}$ 42,863	90	37	55	22	62,5	70	31,1	35,1	23,2	0,98	4 000	0,91	YSA 210-2FK	HA 2310	
$1\frac{3}{4}$ 44,45	90	37	55	22	62,5	70	31,1	35,1	23,2	0,98	4 000	0,88	YSA 210-2FK	HE 2310	
$1\frac{15}{16}$ 49,213	100	40	59	25	69	75	32,5	43,6	29	1,25	3 600	1,1	YSA 211-2FK	HA 2311	
2 50,8	100	40	59	25	69	75	32,5	43,6	29	1,25	3 600	1,1	YSA 211-2FK	HE 2311	
$2\frac{1}{8}$ 53,975	110	42,5	62	26	75,6	80	33,8	52,7	36	1,53	3 400	1,4	YSA 212-2FK	HS 2312	
$2\frac{3}{16}$ 55,563	120	43,5	65	27	82,5	85	35,4	57,2	40	1,7	3 000	1,9	YSA 213-2FK	HA 2313	
$2\frac{1}{4}$ 57,15	120	43,5	65	27	82,5	85	35,4	57,2	40	1,7	3 000	1,8	YSA 213-2FK	HE 2313	
$2\frac{3}{8}$ 60,325	120	43,5	65	27	82,5	85	35,4	57,2	40	1,7	3 000	1,7	YSA 213-2FK	HS 2313	

¹⁾ Distance before the sleeve is driven into the bearing bore (sleeve and inner ring bore at starting position).

2.9 Y-bearings with a standard inner ring, metric shafts d 17 – 60 mm

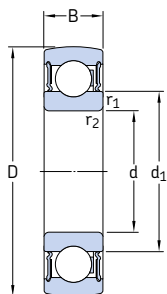

Dimensions					Basic load ratings		Fatigue load limit	Limiting speed	Mass	Designation
d	D	B	d ₁	r _{1,2} min.	C	C ₀	P _u			
mm					kN		kN	r/min	kg	-
17	40	12	24,5	0,6	9,56	4,75	0,2	12 000	0,06	1726203-2RS1
20	47	14	28,8	1	12,7	6,55	0,28	10 000	0,1	1726204-2RS1
25	52	15	34,3	1	14	7,8	0,335	8 500	0,11	1726205-2RS1
	62	17	36,6	1,1	22,5	11,6	0,49	7 500	0,2	1726305-2RS1
30	62	16	40,3	1	19,5	11,2	0,475	7 500	0,18	1726206-2RS1
	72	19	44,6	1,1	28,1	16	0,67	6 300	0,3	1726306-2RS1
35	72	17	46,9	1,1	25,5	15,3	0,655	6 300	0,25	1726207-2RS1
	80	21	49,5	1,5	33,2	19	0,815	6 000	0,4	1726307-2RS1
40	80	18	52,6	1,1	30,7	19	0,8	5 600	0,32	1726208-2RS1
	90	23	56,1	1,5	41	24	1	5 000	0,55	1726308-2RS1
45	85	19	57,6	1,1	33,2	21,6	0,915	5 000	0,37	1726209-2RS1
	100	25	62,1	1,5	52,7	31,5	1,34	4 500	0,73	1726309-2RS1
50	90	20	62,5	1,1	35,1	23,2	0,98	4 800	0,41	1726210-2RS1
	110	27	68,7	2	61,8	38	1,6	4 300	0,95	1726310-2RS1
55	100	21	69	1,5	43,6	29	1,25	4 300	0,54	1726211-2RS1
60	110	22	75,5	1,5	52,7	36	1,53	4 000	0,75	1726212-2RS1

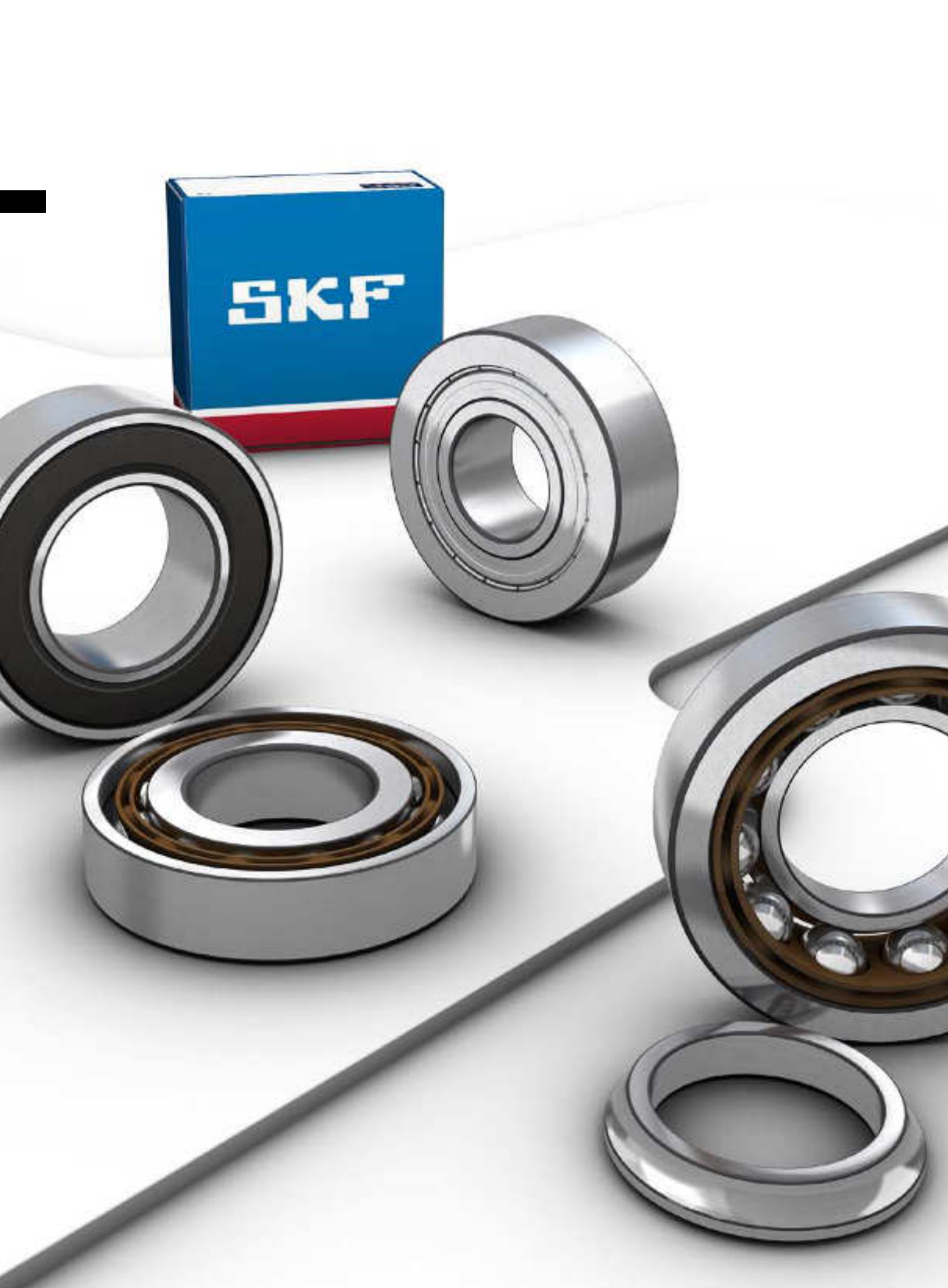

SKF

3 Angular contact ball bearings



Designs and variants	476	Design of bearing arrangements	498
Single row angular contact ball bearings	476	Single row angular contact ball bearings	498
Basic design bearings	477	Proper adjustment	498
Bearings for universal matching	477	Axial loads in one direction	498
Double row angular contact ball bearings	478	Load ratio	498
Basic design bearings	479	Four-point contact ball bearings	499
Bearings with a two-piece inner ring	479	Used as a thrust bearing	499
Four-point contact ball bearings	480	Vertical shafts	499
Cages	481	Load ratio	499
Sealing solutions	482	Designation system	504
Shields	482	Product tables	
Contact seals	482	3.1 Single row angular contact ball bearings	506
Greases for capped bearings	483	3.2 Double row angular contact ball bearings	522
Locating slots	484	3.3 Capped double row angular contact ball bearings	526
Performance classes	485	3.4 Four-point contact ball bearings	530
SKF Explorer bearings	485	Other angular contact ball bearings	
SKF Energy Efficient (E2) bearings	485	Bearings with Solid Oil	1185
Bearing data	487	SKF DryLube bearings	1191
(Dimension standards, tolerances, contact angle, internal clearance, preload, misalignment, friction, starting torque, power loss, defect frequencies)		NoWear coated bearings	1241
Loads	493	Super-precision bearings	→ skf.com/super-precision
(Minimum load, equivalent loads)		Hybrid bearings	→ skf.com/super-precision
Load carrying capacity of bearing pairs	494		
Calculating the axial load for bearings mounted singly or paired in tandem	495		
Temperature limits	497		
Permissible speed	497		

Designs and variants

Angular contact ball bearings have raceways in the inner and outer rings that are displaced with respect to each other in the direction of the bearing axis. This means that they are designed to accommodate combined loads, i.e. simultaneously acting radial and axial loads.

The axial load carrying capacity of angular contact ball bearings increases with increasing contact angle. The contact angle is defined as the angle between the line joining the points of contact of the ball and the raceways in the radial plane, along which the load is transmitted from one raceway to another, and a line perpendicular to the bearing axis (→ fig. 1).

SKF angular contact ball bearings are manufactured in a wide variety of designs and sizes. The most commonly used designs are:

- single row angular contact ball bearings
- double row angular contact ball bearings
- four-point contact ball bearings

More information

Bearing life and load ratings 63

Design considerations 159

Bearing systems 160

Recommended fits 169

Abutment and fillet dimensions 208

Lubrication 239

Mounting, dismantling and bearing care 271

Mounting instructions for individual bearings → skf.com/mount

Fig. 1

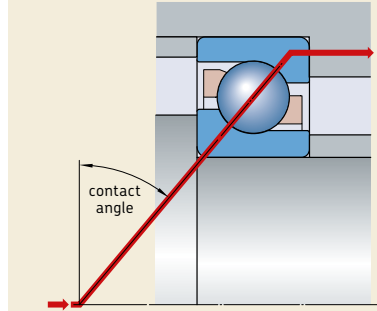

Angular contact ball bearings listed in this catalogue constitute the basic SKF assortment and are only part of the total assortment. Other SKF angular contact ball bearings include:

- Super-precision angular contact ball bearings
For additional information, refer to the product information available online at skf.com/super-precision.
- Thin section angular contact ball bearings
For additional information, contact the SKF application engineering service.
- Hub bearing units
Information about these products can be supplied on request.

Angular contact ball bearings with a larger size than those listed in the product tables are available on request. For information about these bearings, refer to the product information available online at skf.com/bearings, or contact the SKF application engineering service.

Single row angular contact ball bearings

SKF single row angular contact ball bearings (→ fig. 2) can accommodate axial loads in one direction only. A single row bearing is typically adjusted against a second bearing.

The bearings are non-separable and the bearing rings have one high and one low shoulder. The low shoulder enables a large number of balls to be incorporated in the bearing, giving it a relatively high load carrying capacity.

The standard assortment of SKF single row angular contact ball bearings comprises bearings in the 72 B(E) and 73 B(E) series. Some sizes in the 70 B series are also available.

Matrix 1 (→ **page 500**) provides an overview of the standard assortment. In addition, SKF single row angular contact ball bearings are available in many other designs, dimension series, and sizes. For additional information, refer to the product information available online at skf.com/bearings.

Basic design bearings

Basic design bearings are intended for arrangements where only one bearing is used at each bearing position. They have Normal tolerances concerning bearing width and stand-out of the rings. Therefore, they are not suitable for mounting immediately adjacent to each other.

Bearings for universal matching

Bearings for universal matching are intended to be used in sets. The width and the stand-out of the rings are manufactured to close tolerances. When two bearings are mounted immediately adjacent to each other, a given internal clearance or preload or an even load distribution between the two bearings is obtained without the use of shims or similar devices.

Bearings for universal matching can also be beneficial in arrangements with single bearings. Most bearings belong to the SKF Explorer performance class and as such have higher precision, increased load carrying capacity and speed capability.

Bearings for universal matching in the 72 B(E) and 73 B(E) series are identified by the suffix CA, CB or CC for internal clearance or GA, GB or GC for preload. Bearings for universal matching in the 70 B series are identified by the suffix G for clearance. When ordering, indicate the number of individual bearings required and not the number of sets.

Fig. 2

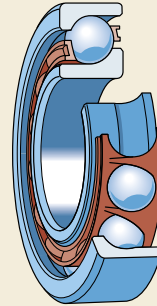

3 Angular contact ball bearings

Paired mounting

Paired mounting can be done in three ways (→ fig. 3):

- **Tandem arrangement**
A tandem arrangement is used when the load carrying capacity of a single bearing is inadequate. When arranged in tandem, the load lines are parallel and the radial and axial loads are equally shared by the bearings. However, the bearing set can accommodate axial loads in one direction only. If axial loads act in both directions, a third bearing, adjusted against the tandem pair, must be added.
- **Back-to-back arrangement**
Mounting two bearings back-to-back provides a relatively stiff bearing arrangement, which can also accommodate tilting moments. When arranged back-to-back, the load lines diverge toward the bearing axis. Axial loads in both directions can be accommodated, but only by one bearing in each direction.
- **Face-to-face arrangement**
Mounting two bearings face-to-face is not as stiff as a back-to-back arrangement, but less sensitive to misalignment. When arranged face-to-face, the load lines converge toward the bearing axis. Axial loads in both directions can be accommodated, but only by one bearing in each direction.

Double row angular contact ball bearings

SKF double row angular contact ball bearings (→ fig. 4) correspond in design to two single row angular contact ball bearings arranged back-to-back, but take up less axial space. They can accommodate radial loads as well as axial loads in both directions. They provide stiff bearing arrangements and are able to accommodate tilting moments.

The standard assortment of SKF double row angular contact ball bearings comprises bearings in the 32 A, 33 A and 33 D series. **Matrix 2** (→ page 501) provides an overview of the standard assortment. For information about other double row angular contact ball bearings, refer to the product information available online at skf.com/bearings.

Bearings in the 52 and 53 series are no longer available from SKF and have been replaced with 32 and 33 series bearings. With the exception of size 3200, 32 and 33 series bearings are dimensionally interchangeable with bearings in the 52 and 53 series. Size 3200 has a width of 14 mm instead of 14,3 mm.

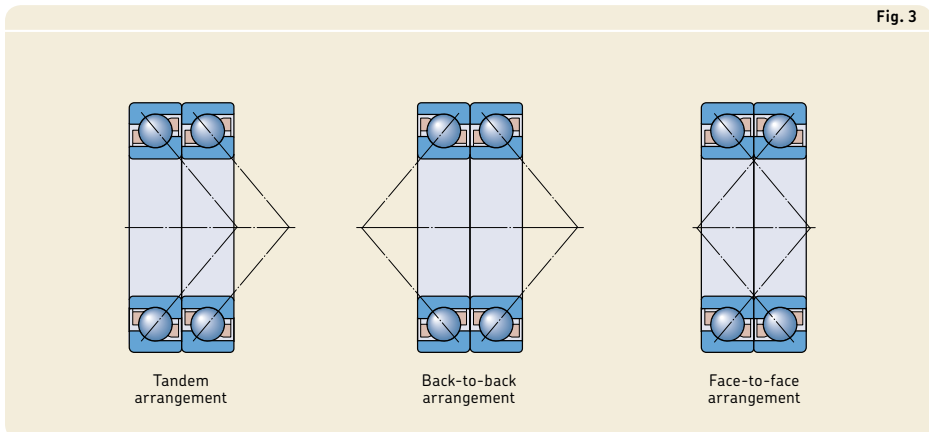

Fig. 3

Basic design bearings

Basic design bearings (designation suffix A) have an optimized internal geometry to provide high radial and axial load carrying capacity and quiet operation. Basic design bearings that are also available capped may have recesses in the inner and outer rings (→ **fig. 5**).

Bearings with a two-piece inner ring

Bearings with a two-piece inner ring (→ **fig. 6**) incorporate a large number of large balls, giving the bearing its high load carrying capacity, especially in the axial direction.

Bearings in the 33 D series are separable, i.e. the outer ring with ball and cage assemblies can be mounted independently of the inner ring halves.

Bearings in the 33 DNRCBM series are non-separable. They have a snap ring groove with a snap ring in the outer ring, enabling simple and space-saving axial location in the housing. Bearings in the 33 DNRCBM series have been designed specifically for centrifugal pumps, but can also be used in other applications.

Fig. 4

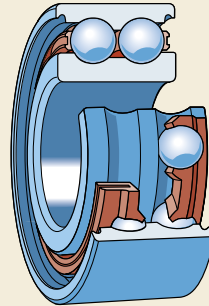

Fig. 5

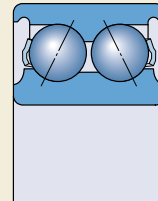
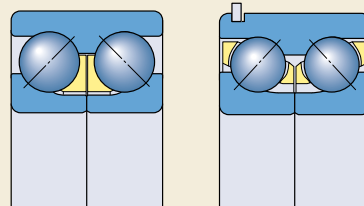

Fig. 6



33 D

33 DNRCBM

3 Angular contact ball bearings

Four-point contact ball bearings

Four-point contact ball bearings (→ **fig. 7**) are radial single row angular contact ball bearings with raceways that are designed to support axial loads in both directions. For a given axial load, a limited radial load can be supported (→ *Load ratio*, **page 499**). These bearings take up considerably less axial space than double row bearings.

The inner ring is split. This enables a large number of balls to be incorporated in the bearing, giving the bearing its high load carrying capacity. The bearings are separable, i.e. the outer ring with ball and cage assembly can be mounted separately from the two inner ring halves.

Both inner ring halves of SKF Explorer four-point contact ball bearings have a recessed shoulder. This improves oil flow when the bearing is used together with an SKF cylindrical roller bearing (→ **fig. 12**, **page 499**). In addition, these recesses can be used to facilitate dismounting.

The standard assortment of SKF four-point contact ball bearings comprises bearings in the QJ 2 and QJ 3 series. **Matrix 3** (→ **page 502**) provides an overview of the standard assortment. For information about other four-point contact ball bearings, refer to the product information available online at skf.com/bearings.

Fig. 7

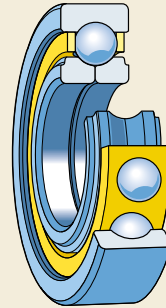

Cages for single row angular contact ball bearings
Standard assortment → **matrix 1**, **page 500**

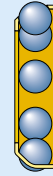
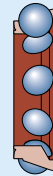

Cage type	Window-type, ball centred	Window-type, ball centred	
Material	PA66, glass fibre reinforced	PEEK, glass fibre reinforced	Stamped brass, stamped steel ¹⁾
Suffix	P	PH	Y, J ¹⁾

¹⁾ Check availability prior to ordering

Cages

Depending on their design, series and size, SKF angular contact ball bearings are fitted with one of the cages shown in **table 1**. Double row bearings are equipped with two cages. The stamped steel cage in double row bearings is not identified in the bearing designation. For information about the availability of cages for the various bearing designs, series and sizes, refer to **matrices 1 to 3** (→ **pages 500 to 502**).

The lubricants generally used for rolling bearings do not have a detrimental effect on cage properties. However, some synthetic oils and greases with a synthetic oil base and lubricants containing a high proportion of EP additives, when used at high temperatures, can have a detrimental effect on polyamide cages. For additional information about the suitability of cages, refer to **Cages** (→ **page 37**) and **Cage materials** (→ **page 152**).

Table 1

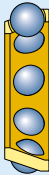
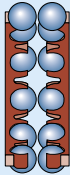
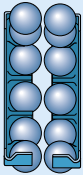
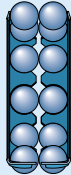
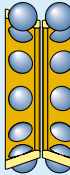
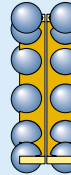
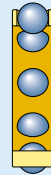
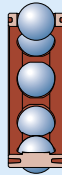
Cages for double row angular contact ball bearings Standard assortment → matrix 2, page 501						Cages for four-point contact ball bearings Standard assortment → matrix 3, page 502	
							
Window-type, ball centred	Snap-type, ball centred	Snap-type, ball centred	Snap-type, crown, ball centred	Window-type, ball centred	Prong-type, outer ring centred	Window-type, outer ring centred	Window-type, lubrication grooves in the guiding surface, outer ring centred
Machined brass, machined steel ¹⁾	PA66, glass fibre reinforced	Stamped steel	Stamped steel	Machined brass	Machined brass	Machined brass	PEEK, glass fibre reinforced
M, F ¹⁾	TN9	–	–	M	MA	MA	PHAS

3 Angular contact ball bearings

Sealing solutions

SKF supplies the most common basic design double row angular contact ball bearings capped with a contact seal or shield on both sides (→ **matrix 2, page 501**). For additional information about the suitability of seals or shields under various conditions, refer to *Sealing solutions* (→ **page 226**).

Bearings capped on both sides are lubricated for the life of the bearing and should not be washed or relubricated. The bearings are considered maintenance-free. If they are to be hot mounted, an induction heater should be used. SKF does not recommend heating capped bearings above 80 °C (175 °F). However, if higher temperatures are necessary make sure that the temperature does not exceed the permissible temperature of either the seal or grease, whichever is lowest. During start-up, grease may leak at the inner ring. For bearing arrangements where this would be detrimental, special design steps must be undertaken. For additional information, contact the SKF application engineering service.

Shields

Shields are made of sheet steel. SKF supplies shields in two designs. The shields used in smaller bearings have an extension in the shield bore to form a long, narrow gap with the inner ring shoulder (→ **fig. 8a**). The shields used in larger bearings and in all SKF Explorer bearings extend into a recess on the inner ring (→ **fig. 8b**).

SKF double row angular contact ball bearings with a shield on both sides are identified by the designation suffix 2Z.

Contact seals

Contact seals (→ **fig. 9**) are made of NBR and are reinforced with a sheet steel insert. These seals, which are fitted in a recess on the outer ring, make good, positive contact with the recess. The seal lip exerts light pressure against the recess on the inner ring to provide an effective seal.

SKF double row angular contact ball bearings with a contact seal on both sides are identified by the designation suffix 2RS1.

Fig. 8

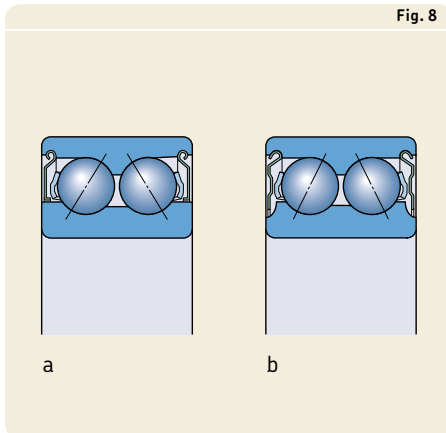
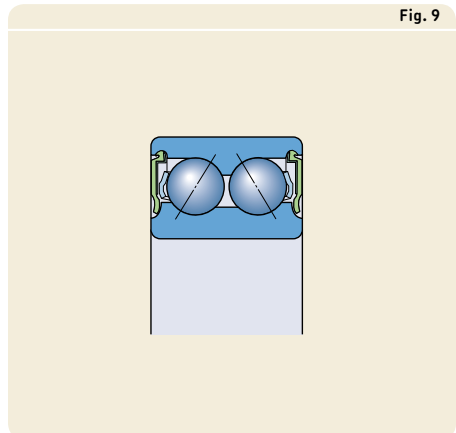

Fig. 9



Greases for capped bearings

Capped double row angular contact ball bearings are filled with one of the following greases (→ table 2):

- The standard grease is GJN.
- In Europe, MT33 is commonly used and widely available.
- SKF Energy Efficient angular contact ball bearings are filled with the low-friction grease GE2.
- Other greases listed in **table 2** can be supplied on request.

The standard grease is not identified in the bearing designation (no designation suffix). Other greases are indicated by the corresponding grease suffix.

Table 2

Technical specifications of SKF standard and special greases for capped double row angular contact ball bearings

Grease	Temperature range ¹⁾	Thickener	Base oil type	NLGI consistency class	Base oil viscosity [mm ² /s]	
					at 40°C (105 °F)	at 100 °C (210 °F)
GJN		Polyurea soap	Mineral	2	115	12,2
MT33		Lithium soap	Mineral	3	100	10
VT113		Lithium complex	Mineral paraffinic	3	113	12,1
WT		Polyurea soap	Ester	2-3	70	9,4
GWF		Diurea	Synthetic SHC/ether	2-3	67,5	9,6
GE2		Lithium soap	Synthetic	2	25	4,9

¹⁾ Refer to the SKF traffic light concept → page 244

3 Angular contact ball bearings

Locating slots

SKF four-point contact ball bearings can be supplied with two locating slots in the outer ring (→ **fig. 10**) to prevent it from turning (designation suffix N2). The locating slots are positioned 180° apart. The dimensions and tolerances of the locating slots are in accordance with ISO 20515 and are listed in **table 3**. Some SKF single row angular contact ball bearings can be supplied with one locating slot in the outer ring (designation suffix N1).

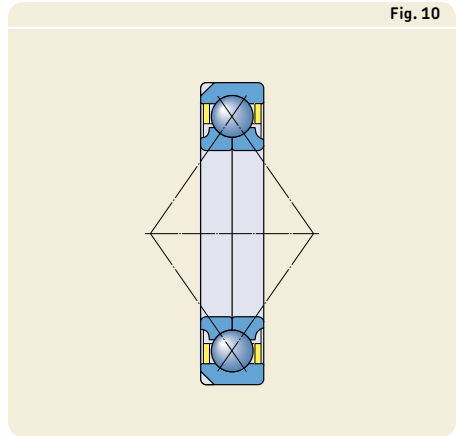
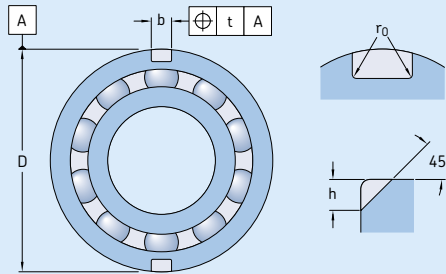

Fig. 10

Table 3

Locating slots in the outer ring of four-point contact ball bearings



Outside diameter		Dimensions			Diameter series 3			Tolerance ¹⁾
D	over	Diameter series 2		r_0	Diameter series 3		t max.	
	incl.	h	b		h	b		
mm		mm			mm			
35	45	2,5	3,5	0,5	–	–	0,2	
45	60	3	4,5	0,5	3,5	4,5	0,2	
60	72	3,5	4,5	0,5	3,5	4,5	0,2	
72	95	4	5,5	0,5	4	5,5	0,2	
95	115	5	6,5	0,5	5	6,5	0,2	
115	130	6,5	6,5	0,5	8,1	6,5	0,2	
130	145	8,1	6,5	1	8,1	6,5	0,2	
145	170	8,1	6,5	1	10,1	8,5	0,2	
170	190	10,1	8,5	2	11,7	10,5	0,2	
190	210	10,1	8,5	2	11,7	10,5	0,2	
210	240	11,7	10,5	2	11,7	10,5	0,2	
240	270	11,7	10,5	2	11,7	10,5	0,2	
270	400	12,7	10,5	2	12,7	10,5	0,4	

¹⁾ Other tolerances are in accordance with ISO 20515.

Performance classes

SKF Explorer bearings

In response to the ever-demanding performance requirements of modern machinery, SKF developed the SKF Explorer performance class of rolling bearings.

SKF Explorer angular contact ball bearings realized this substantial improvement in performance by optimizing the internal geometry and surface finish of all contact surfaces, redesigning the cage, combining the extremely clean and homogenous steel with a unique heat treatment and improving the quality and consistency of the balls.

These improvements provide the following benefits:

- higher dynamic load carrying capacity
- less sensitivity to heavy axial loads
- improved wear-resistance
- reduced noise and vibration levels
- less frictional heat
- significantly extended bearing service life

These bearings reduce environmental impact by enabling downsizing and reducing both lubricant and energy use. Just as importantly, SKF Explorer bearings can reduce the need for maintenance and contribute to increased productivity.

SKF Explorer bearings are shown with an asterisk in the product tables. The bearings retain the designation of earlier standard bearings. However, each bearing and its box are marked with the name "SKF Explorer".

SKF Energy Efficient (E2) bearings

To meet the ever-increasing demand to reduce friction and energy use, SKF has developed the SKF Energy Efficient (E2) performance class of rolling bearings. SKF E2 angular contact ball bearings are characterized by a frictional moment in the bearing that is at least 30% lower when compared to a same-sized standard SKF bearing. Due to the reduction of the frictional moment, SKF E2 double row angular contact ball bearings run up to 30 °C (55 °F) cooler than standard bearings. This extends grease life and potentially bearing service life.

The bearings realized the substantial reduction of the frictional moment by optimizing the internal geometry of the bearing and applying a new, low-friction grease.

SKF E2 double row angular contact ball bearings are available in the 32 and 33 dimension series (→ **matrix 2, page 501**). The bearings are equipped with a shield on both sides and lubricated for the life of the bearing.

Bearing data

	Single row angular contact ball bearings
Dimension standards	Boundary dimensions: ISO 15 and ISO 12044
Tolerances	Normal
For additional information (→ page 132)	SKF Explorer bearings P6 dimensional accuracy P5 running accuracy
	Values: ISO 492, (→ tables 3 to 5, pages 137 to 139)
Contact angle	40° For a 25° or 30° contact angle, contact SKF.
Internal clearance	Pairs of universally matchable bearings: CB (normal), G Availability CA and CC: (→ matrix 1, page 500) Values: (→ table 5, page 488)
For additional information (→ page 149)	Values apply to unmounted bearing sets, arranged back-to-back or face-to-face under zero measuring load.
Preload	Pairs of universally matchable bearings: GA (light preload) Availability GB and GC: (→ matrix 1, page 500) Values: (→ table 6, page 489)
For additional information (→ page 214)	Values apply to unmounted bearing sets, arranged back-to-back or face-to-face.
Misalignment	Bearing pairs arranged back-to-back: ≈ 2 minutes of arc Bearing pairs arranged face-to-face: ≈ 4 minutes of arc
	The permissible angular misalignment between the inner and outer rings depends on the size and internal design of the bearing, the radial internal clearance in operation and the forces and moments acting on the ...
Friction, starting torque, power loss	Frictional moment, starting torque, and power loss can be calculated as specified under <i>Friction</i> (→ page 97), or using the tools ...
Defect frequencies	Defect frequencies can be calculated using the tools ...

Double row angular contact ball bearings	Four-point contact ball bearings
Boundary dimensions: ISO 15, except for the width of bearing 3200 A Snap rings and grooves: ISO 464, (→ table 4, page 488)	Boundary dimensions: ISO 15 Locating slots: ISO 20515, (→ table 3, page 484)
Normal	Normal P6 on request
SKF Explorer and SKF E2 bearings, 33 DNRCBM series P6	SKF Explorer P6 and width tolerance reduced to 0/-40 µm
32 A and 33 A series: 30° 33 D series: 45° 33 DNRCBM series: 40°	35°
Normal Availability: C3 (→ matrix 2, page 501); for C2 or C4 contact SKF Values: (→ table 7, page 489)	Normal Check availability of C2, C3, C4 or reduced ranges of standard clearance classes Values: ISO 5753-2, (→ table 8, page 490)
-	-
≈ 2 minutes of arc	≈ 2 minutes of arc

... bearing. As a result, only approximate values are listed here. Any misalignment increases bearing noise and reduces bearing service life.

... available online at skf.com/bearingcalculator.

... available online at skf.com/bearingcalculator.

3 Angular contact ball bearings

Table 4

Dimensions of snap ring grooves and snap rings

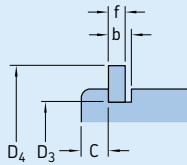

Bearing Designation	Dimensions					Snap ring Designation
	C	b	f	D ₃	D ₄	
–	mm					–
3308 DNRCBM	3,28	2,7	2,46	86,8	96,5	SP 90
3309 DNRCBM	3,28	2,7	2,46	96,8	106,5	SP 100
3310 DNRCBM	3,28	2,7	2,46	106,8	116,6	SP 110
3311 DNRCBM	4,06	3,4	2,82	115,2	129,7	SP 120
3313 DNRCBM	4,06	3,4	2,82	135,2	149,7	SP 140

Table 5

Axial internal clearance of universally matchable single row angular contact ball bearings arranged back-to-back or face-to-face

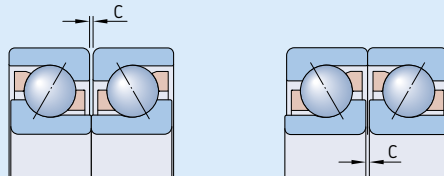

Bore diameter		Axial internal clearance							
d over	incl.	Class		CB		CC		G	
		min.	max.	min.	max.	min.	max.	min.	max.
mm		μm							
–	18	5	13	15	23	24	32	–	–
18	30	7	15	18	26	32	40	–	–
30	50	9	17	22	30	40	48	–	–
50	80	11	23	26	38	48	60	–	–
80	120	14	26	32	44	55	67	–	–
120	160	17	29	35	47	62	74	26	76
160	180	17	29	35	47	62	74	20	72
180	250	21	37	45	61	74	90	20	72
250	280	–	–	–	–	–	–	20	72

Table 6

Preload of universally matchable single row angular contact ball bearings arranged back-to-back or face-to-face

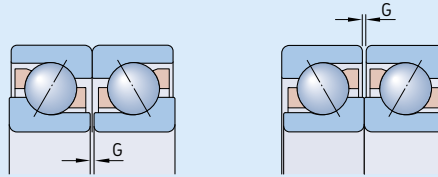

Bore diameter d		Preload Class GA		GB		GC		GD		GE		GF	
over	incl.	min.	max.	max.	min.	max.	min.	max.	min.	max.	min.	max.	max.
mm		µm		N		µm		N		µm		N	
10	18	+4	-4	80	-2	-10	30	330	-8	-16	230	660	
18	30	+4	-4	120	-2	-10	40	480	-8	-16	340	970	
30	50	+4	-4	160	-2	-10	60	630	-8	-16	450	1 280	
50	80	+6	-6	380	-3	-15	140	1 500	-12	-24	1 080	3 050	
80	120	+6	-6	410	-3	-15	150	1 600	-12	-24	1 150	3 250	
120	180	+6	-6	540	-3	-15	200	2 150	-12	-24	1 500	4 300	
180	250	+8	-8	940	-4	-20	330	3 700	-16	-32	2 650	7 500	

Table 7

Axial internal clearance of double row angular contact ball bearings

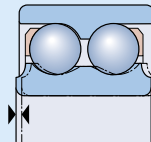

Bore diameter d		Axial internal clearance of bearings in the series 32 A and 33 A								33 D		33 DNRCBM	
over	incl.	C2 min.	max.	Normal min.	max.	C3 min.	max.	C4 min.	max.	min.	max.	min.	max.
mm		µm								µm		µm	
-	10	1	11	5	21	12	28	25	45	25	45	-	-
10	18	1	12	6	23	13	31	27	47	27	47	-	-
18	24	2	14	7	25	16	34	28	48	27	47	6	26
24	30	2	15	8	27	18	37	30	50	30	50	6	26
30	40	2	16	9	29	21	40	33	54	33	54	10	30
40	50	2	18	11	33	23	44	36	58	36	58	10	30
50	65	3	22	13	36	26	48	40	63	40	63	18	38
65	80	3	24	15	40	30	54	46	71	46	71	18	38
80	100	3	26	18	46	35	63	55	83	55	83	-	-
100	110	4	30	22	53	42	73	65	96	65	96	-	-

3 Angular contact ball bearings

Table 8

Axial internal clearance of four-point contact ball bearings

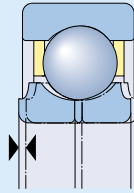

Bore diameter d		Axial internal clearance									
		over	incl.	C2 min.	max.	Normal min.	max.	C3 min.	max.	C4 min.	max.
mm		μm									
10	18			15	65	50	95	85	130	120	165
18	40			25	75	65	110	100	150	135	185
40	60			35	85	75	125	110	165	150	200
60	80			45	100	85	140	125	175	165	215
80	100			55	110	95	150	135	190	180	235
100	140			70	130	115	175	160	220	205	265
140	180			90	155	135	200	185	250	235	300
180	220			105	175	155	225	210	280	260	330

Loads

	Single row angular contact ball bearings	Double row angular contact ball bearings
Minimum load	Minimum axial load for single bearings and bearing pairs arranged in tandem: $F_{am} = k_a \frac{C_0}{1\,000} \left(\frac{n d_m}{100\,000} \right)^2$	–
	Minimum radial load for bearing pairs arranged back-to-back or face-to-face: $F_{rm} = k_r \left(\frac{v n}{1\,000} \right)^{2/3} \left(\frac{d_m}{100} \right)^2$	Minimum radial load: $F_{rm} = k_r \left(\frac{v n}{1\,000} \right)^{2/3} \left(\frac{d_m}{100} \right)^2$
For additional information (→ page 86)	The weight of the components supported by the bearing, together with external forces, generally exceed the requisite minimum load. If this is not the case, the bearing must be subjected to an additional radial or axial load, depending on the bearing type and arrangement, e.g. increasing belt tension,	
Equivalent dynamic bearing load	Single bearings and bearing pairs arranged in tandem: $F_a/F_r \leq 1,14^{(1)} \rightarrow P = F_r$ $F_a/F_r > 1,14^{(1)} \rightarrow P = 0,35 F_r + 0,57 F_a$	$F_a/F_r \leq e \rightarrow P = F_r + Y_1 F_a$ $F_a/F_r > e \rightarrow P = X F_r + Y_2 F_a$
	Bearing pairs arranged back-to-back or face-to-face: $F_a/F_r \leq 1,14 \rightarrow P = F_r + 0,55 F_a$ $F_a/F_r > 1,14 \rightarrow P = 0,57 F_r + 0,93 F_a$	
For additional information (→ page 85)		
Equivalent static bearing load	Single bearings and bearing pairs arranged in tandem: $P_0 = 0,5 F_r + 0,26 F_a^{(1)}$ $P_0 < F_r \rightarrow P_0 = F_r$	$P_0 = F_r + Y_0 F_a$
	Bearing pairs arranged back-to-back or face-to-face: $P_0 = F_r + 0,52 F_a$	
For additional information (→ page 88)		

¹⁾ When determining the axial load F_a , refer to *Calculating the axial load for bearings mounted singly or paired in tandem* (→ page 495).

Four-point contact ball bearings	Symbols
<p>Minimum axial load:</p> $F_{am} = k_a \frac{C_0}{1\,000} \left(\frac{n d_m}{100\,000} \right)^2$	<p>C_0 = basic static load rating [kN] (→ product tables) d_m = bearing mean diameter [mm] = 0,5 (d + D) e = calculation factor for double row bearings (→ table 10, page 494)</p>
<p>–</p>	<p>F_a = axial load [kN] F_{am} = minimum axial load [kN] F_r = radial load [kN] F_{rm} = minimum radial load [kN] k_a = minimum axial load factor (→ table 9, page 494) k_r = minimum radial load factor (→ table 9, page 494)</p>
<p>adjusting the inner or outer rings against each other or by using springs.</p>	<p>n = rotational speed [r/min] P = equivalent dynamic bearing load [kN] P_0 = equivalent static bearing load [kN] X, Y_0, Y_1, Y_2 = calculation factors for double row bearings, depending on the bearing series (→ table 10, page 494)</p>
<p>Locating bearings to accommodate radial and axial load:</p> $F_a/F_r \leq 0,95^2 \rightarrow P = F_r + 0,66 F_a$ $F_a/F_r > 0,95^2 \rightarrow P = 0,6 F_r + 1,07 F_a$	<p>v = actual operating viscosity of the lubricant [mm²/s]</p>
<p>Thrust bearings with radial freedom in combination with a radial bearing:</p> $P = 1,07 F_a$	
$P_0 = F_r + 0,58 F_a$	

²⁾ For a proper function, SKF recommends the axial load $F_a \geq 1,27 F_r$.

3 Angular contact ball bearings

Table 9

Minimum load factors		
Bearing series	Minimum load factors	
	k_a	k_r
Single row bearings		
70 B	0,9	0,083
72 BE	1,4	0,095
72 B	1,2	0,08
73 BE	1,6	0,1
73 B	1,4	0,09
Double row bearings		
32 A	–	0,06
33 A	–	0,07
33 D	–	0,095
33 DNRCBM	–	0,095
Four-point contact bearings		
QJ 2	1	–
QJ 3	1,1	–

Load carrying capacity of bearing pairs

The values for basic load ratings and fatigue load limits listed in the product tables apply to single bearings. For bearing pairs mounted immediately adjacent to each other the following values apply:

- basic dynamic load rating for standard bearings in all arrangements and for SKF Explorer bearings in a back-to-back or face-to-face arrangement
 $C = 1,62 C_{\text{single bearing}}$
- basic dynamic load rating for SKF Explorer bearings in a tandem arrangement
 $C = 2 C_{\text{single bearing}}$
- basic static load rating
 $C_0 = 2 C_{0 \text{ single bearing}}$
- fatigue load limit
 $P_u = 2 P_{u \text{ single bearing}}$

Table 10

Calculation factors for double row angular contact ball bearings					
Bearing series	Calculation factors				
	e	X	Y_1	Y_2	Y_0
32 A, 33 A	0,8	0,63	0,78	1,24	0,66
33 D	1,34	0,54	0,47	0,81	0,44
33 DNRCBM	1,14	0,57	0,55	0,93	0,52

Calculating the axial load for bearings mounted singly or paired in tandem

When a radial load is applied to a single row angular contact ball bearing, the load is transmitted from one raceway to the other at an angle to the bearing axis and an internal axial load is induced. This must be considered when calculating the equivalent bearing loads for bearing arrangements consisting of two single bearings and/or bearing pairs arranged in tandem.

The necessary equations are provided in **table 11** (→ **page 496**), for the various bearing arrangements and load cases. The equations are only valid if the bearings are adjusted against each other to practically zero clearance, but without any preload. In the arrangements shown, bearing A is subjected to a radial load F_{rA} and bearing B to a radial load F_{rB} . Both F_{rA} and F_{rB} are always considered positive, even when they act in the direction opposite to what is shown in the figures. The radial loads act at the pressure centres of the bearings (→ distance a in the product tables).

The variable R from **table 11** (→ **page 496**) takes into account the contact conditions inside the bearing. The values for R can be obtained from **diagram 1**, as a function of the ratio K_a/C . K_a is the external axial force acting

on the shaft or on the housing and C is the basic dynamic load rating of the bearing, which must accommodate the external axial force.

Use $R = 1$ for $K_a = 0$.

3

Diagram 1

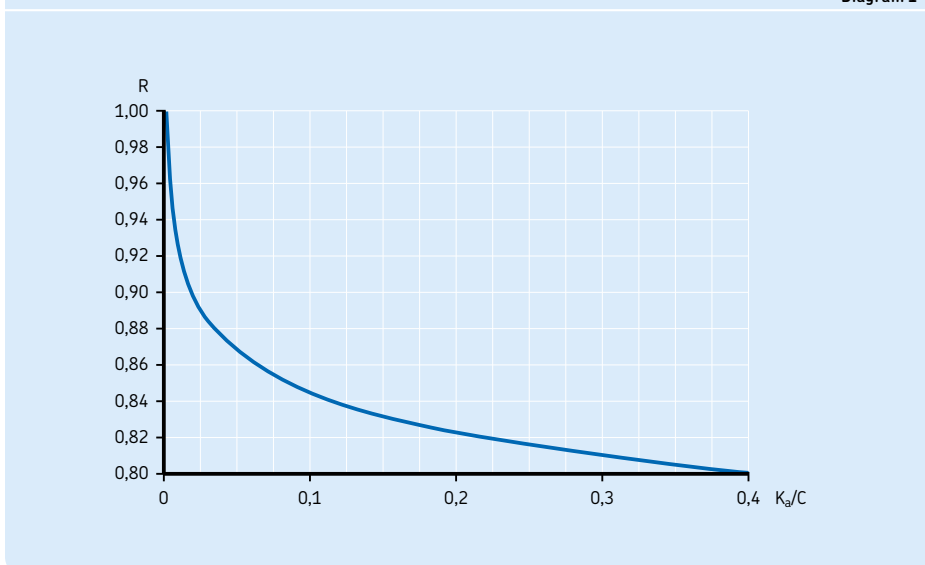

3 Angular contact ball bearings

Table 11

Axial loading of bearing arrangements incorporating two single row B or BE design angular contact ball bearings and/or bearing pairs in tandem

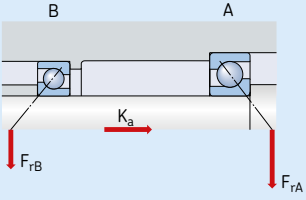
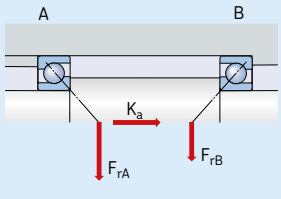
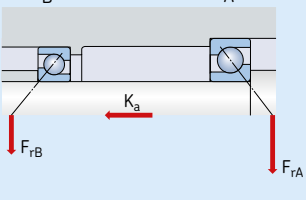
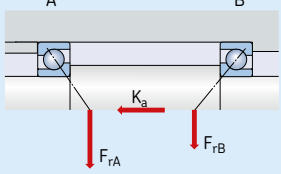
Bearing arrangement	Load case	Axial loads	
<p>Back-to-back</p> 	<p>Case 1a</p> $F_{rA} \geq F_{rB}$ $K_a \geq 0$	$F_{aA} = R F_{rA}$	$F_{aB} = F_{aA} + K_a$
<p>Face-to-face</p> 	<p>Case 1b</p> $F_{rA} < F_{rB}$ $K_a \geq R (F_{rB} - F_{rA})$	$F_{aA} = R F_{rA}$	$F_{aB} = F_{aA} + K_a$
<p>Back-to-back</p> 	<p>Case 2a</p> $F_{rA} \leq F_{rB}$ $K_a \geq 0$	$F_{aA} = F_{aB} + K_a$	$F_{aB} = R F_{rB}$
<p>Face-to-face</p> 	<p>Case 2b</p> $F_{rA} > F_{rB}$ $K_a \geq R (F_{rA} - F_{rB})$	$F_{aA} = F_{aB} + K_a$	$F_{aB} = R F_{rB}$
	<p>Case 2c</p> $F_{rA} > F_{rB}$ $K_a < R (F_{rA} - F_{rB})$	$F_{aA} = R F_{rA}$	$F_{aB} = F_{aA} - K_a$

Temperature limits

The permissible operating temperature for angular contact ball bearings can be limited by:

- the dimensional stability of the bearing rings and balls
- the cage
- the seals
- the lubricant

When temperatures outside the permissible range are expected, contact the SKF application engineering service.

Bearing rings and balls

SKF angular contact ball bearings undergo a special heat treatment. The bearings are heat stabilized up to at least 150 °C (300 °F).

Cages

Steel, brass or PEEK cages can be used at the same operating temperatures as the bearing rings and balls. For temperature limits of cages made of other polymer materials, refer to *Cage materials* (→ **page 152**).

Seals

The permissible operating temperature for NBR seals is -40 to +100 °C (-40 to +210 °F). Temperatures up to 120 °C (250 °F) can be tolerated for brief periods.

Lubricants

Temperature limits for greases used in capped SKF angular contact ball bearings are provided in **table 2** (→ **page 483**). Temperature limits for other SKF greases are provided under *Lubrication* (→ **page 239**).

When using lubricants not supplied by SKF, the temperature limits should be evaluated according to the SKF traffic light concept (→ **page 244**).

Permissible speed

The permissible speed can be estimated using the speed ratings listed in the product tables and applying the information provided under *Speeds* (→ **page 117**). If no reference speed is listed in the product tables, the limiting speed is the permissible speed.

Bearing pairs

For bearings arranged in pairs, the permissible speed calculated for a single bearing should be reduced to approximately 80% of the quoted value.

Design of bearing arrangements

Single row angular contact ball bearings

Proper adjustment

Single row angular contact ball bearings must either be used with a second bearing or in sets (→ **fig. 11**). The bearings must be adjusted against each other until the requisite clearance or preload is obtained (→ *Bearing preload*, **page 214**).

When universally matchable bearings are mounted immediately adjacent to each other, there is no need for adjustment. The requisite clearance or preload is obtained by choosing bearings from an appropriate clearance or preload class and by applying suitable fits for the bearings on the shaft and in the housing.

The performance and operational reliability of single bearings depend on proper adjustment while universally matchable bearings depend on the correct selection of clearance or preload. If there is too much clearance in the bearing arrangement during operation, the load carrying capacity of the bearings is not fully utilized. Excessive preload produces more

friction and higher operating temperatures, leading to a reduction in bearing service life.

Axial loads in one direction

Back-to-back and face-to-face arrangements require special attention when the axial load acts predominantly in one direction. This creates unfavourable rolling conditions for the balls of the axially unloaded bearing and can lead to increased noise levels, discontinuity in the lubricant film and increased stresses on the cage. When the axial load acts predominantly in one direction, SKF recommends zero operating clearance, which can be attained by using springs.

Load ratio

Because of the 40° contact angle, favourable rolling conditions for bearings in the 70 B, 72 B(E) and 73 B(E) series require a load ratio of $F_a/F_r \geq 1$. A load ratio of $F_a/F_r < 1$ can reduce bearing service life.

Fig. 11

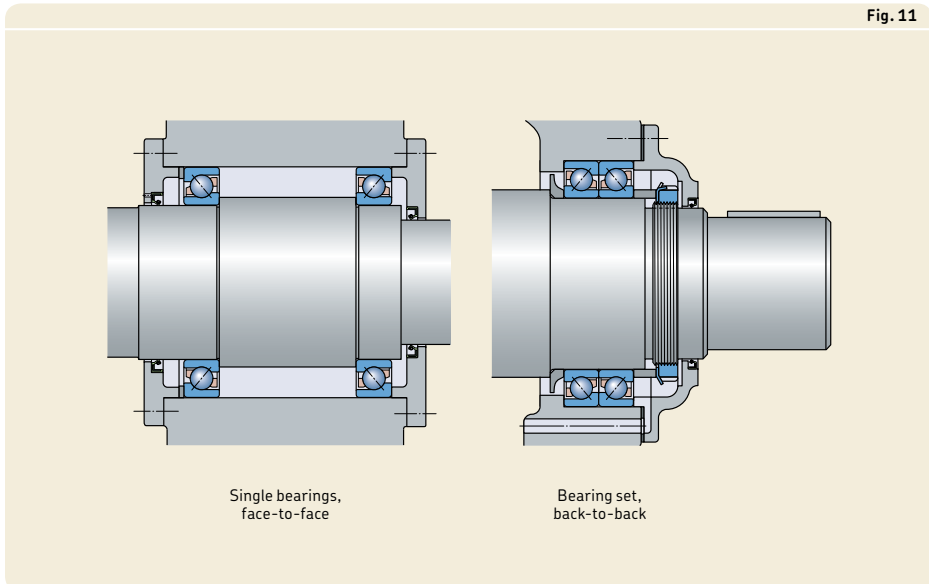

Four-point contact ball bearings

Used as a thrust bearing

Four-point contact ball bearings are often used as pure thrust bearings, together with a radial bearing (→ **fig. 12**). When used in this way, the bearing should be mounted with radial clearance in the housing.

When a four-point contact ball bearing is used together with a cylindrical roller bearing, the radial internal clearance of the cylindrical roller bearing should be smaller than the theoretical radial internal clearance of the four-point contact ball bearing after both have been mounted. The theoretical radial clearance can be calculated from

$$C_r = 0,7 C_a$$

where

C_r = theoretical radial internal clearance

C_a = axial internal clearance (→ **table 8, page 490**)

The outer ring of the four-point contact ball bearing must be able to accommodate thermal movements. Therefore, it should not be clamped axially, but a small gap should be maintained between the outer ring and the cover flange. To prevent the outer ring from turning, bearings with locating slots should be used (→ **fig. 12**). If clamping the outer ring cannot be avoided, the outer ring must be carefully centred during mounting.

Vertical shafts

When four-point contact ball bearings with a machined brass cage (designation suffix MA) are used on a vertical shaft, the limiting speed listed in the product tables should be reduced to 70% of the value listed in the product tables. As with all vertical shafts, be sure that the bearings are adequately lubricated.

Load ratio

Four-point contact ball bearings do not function properly unless the balls contact only one inner ring raceway and the opposite side of the outer ring raceway. This is the case when the load ratio $F_a/F_r \geq 1,27$. A load ratio of $F_a/F_r < 1,27$ can reduce bearing service life.

Fig. 12

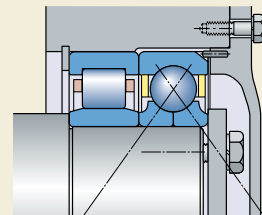

SKF double row angular contact ball bearings – standard assortment

Bore diameter [mm]	Basic design bearings			Bearings with shields ¹⁾				Bearings with seals ¹⁾			Bearings with a two-piece inner ring		Bearing size															
	32..A ²⁾	32..ATN9	32..ATN9/C2	32..ATN9/C3	33..A ²⁾	33..ATN9	33..ATN9/C3	E2.32..A-ZZ	32..A-ZZ/MT33	32..A-ZZ/C3MT33	32..A-ZZTN9/MT33	32..A-ZZTN9/C3MT33		E2.33..A-ZZ	33..A-ZZ/C3MT33	33..A-ZZTN9/MT33	33..A-ZZTN9/C3MT33	32..A-2RS1 ²⁾	32..A-2RS1/MT33	32..A-2RS1TN9/MT33	33..A-2RS1 ²⁾	33..A-2RS1/MT33	33..A-2RS1TN9/MT33	33..D	33..DNRCBM			
10																											00	
12																												01
15																												02
17																												03
20	■	■	■	■	■	■	■	■	■	■	■	■	■	■	■	■	■	■	■	■	■	■	■	■	■	■	■	04
25	■	■	■	■	■	■	■	■	■	■	■	■	■	■	■	■	■	■	■	■	■	■	■	■	■	■	■	05
30	■	■	■	■	■	■	■	■	■	■	■	■	■	■	■	■	■	■	■	■	■	■	■	■	■	■	■	06
35	■	■	■	■	■	■	■	■	■	■	■	■	■	■	■	■	■	■	■	■	■	■	■	■	■	■	■	07
40	■	■	■	■	■	■	■	■	■	■	■	■	■	■	■	■	■	■	■	■	■	■	■	■	■	■	■	08
45	■	■	■	■	■	■	■	■	■	■	■	■	■	■	■	■	■	■	■	■	■	■	■	■	■	■	■	09
50	■	■	■	■	■	■	■	■	■	■	■	■	■	■	■	■	■	■	■	■	■	■	■	■	■	■	■	10
55	■	■	■	■	■	■	■	■	■	■	■	■	■	■	■	■	■	■	■	■	■	■	■	■	■	■	■	11
60	■	■	■	■	■	■	■	■	■	■	■	■	■	■	■	■	■	■	■	■	■	■	■	■	■	■	■	12
65	■	■	■	■	■	■	■	■	■	■	■	■	■	■	■	■	■	■	■	■	■	■	■	■	■	■	■	13
70	■	■	■	■	■	■	■	■	■	■	■	■	■	■	■	■	■	■	■	■	■	■	■	■	■	■	■	14
75	■	■	■	■	■	■	■	■	■	■	■	■	■	■	■	■	■	■	■	■	■	■	■	■	■	■	■	15
80	■	■	■	■	■	■	■	■	■	■	■	■	■	■	■	■	■	■	■	■	■	■	■	■	■	■	■	16
85	■	■	■	■	■	■	■	■	■	■	■	■	■	■	■	■	■	■	■	■	■	■	■	■	■	■	■	17
90	■	■	■	■	■	■	■	■	■	■	■	■	■	■	■	■	■	■	■	■	■	■	■	■	■	■	■	18
95	■	■	■	■	■	■	■	■	■	■	■	■	■	■	■	■	■	■	■	■	■	■	■	■	■	■	■	19
100	■	■	■	■	■	■	■	■	■	■	■	■	■	■	■	■	■	■	■	■	■	■	■	■	■	■	■	20
110	■	■	■	■	■	■	■	■	■	■	■	■	■	■	■	■	■	■	■	■	■	■	■	■	■	■	■	22

- SKF Explorer bearings
- SKF Energy Efficient bearings
- SKF standard bearings

¹⁾ The standard grease for double row angular contact ball bearings is GJN. In Europe, MT33 is commonly used and widely available. Other greases listed in **table 2** (→ **page 483**) are available on request.

²⁾ Several variants are possible. Contact SKF prior to ordering.

Designation system

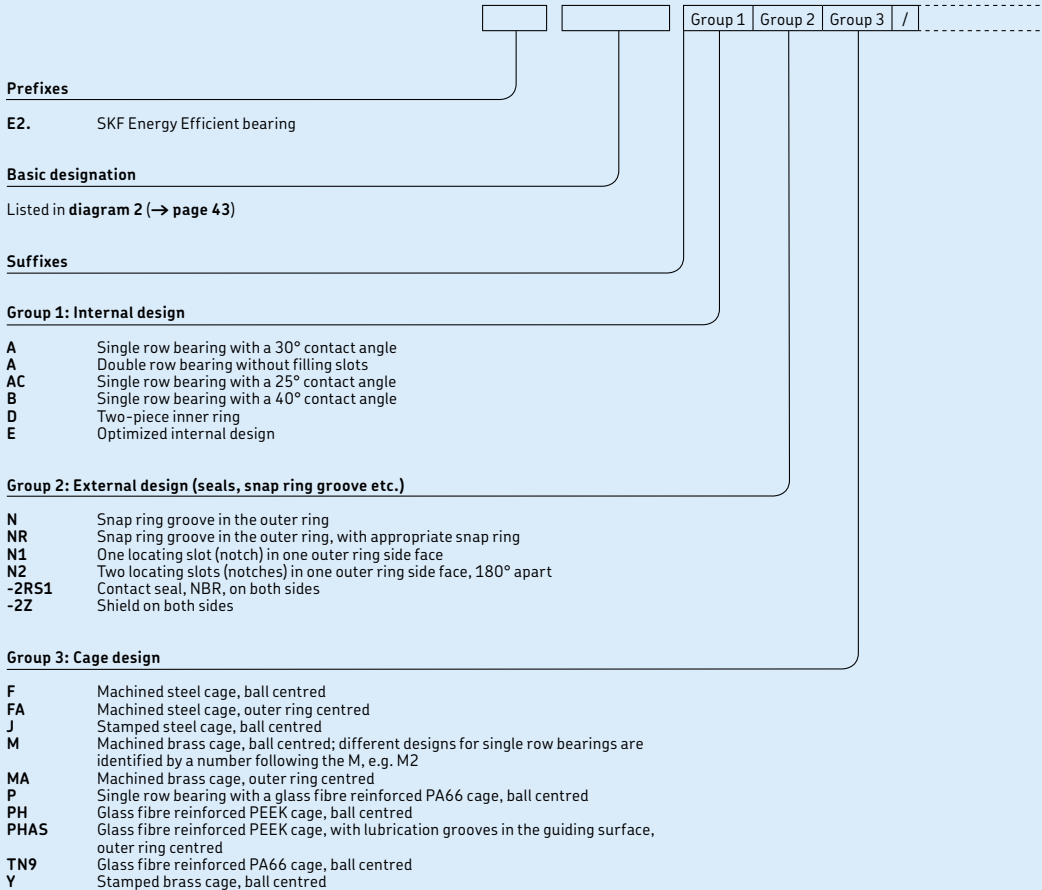

Group 4					
4.1	4.2	4.3	4.4	4.5	4.6

Group 4.6: Other variants

Group 4.5: Lubrication

GWF	} Grease suffixes (→ table 2, page 483)
MT33	
VT113	
WT	

Group 4.4: Stabilization

S1 Bearing rings heat stabilized for operating temperatures ≤ 200 °C (390 °F)

Group 4.3: Bearing sets, matched bearings

DB Two bearings matched for mounting back-to-back
DF Two bearings matched for mounting face-to-face
DT Two bearings matched for mounting in tandem

Group 4.2: Accuracy, clearance, preload, quiet running

B20 Reduced width tolerance
P5 Dimensional and running accuracy to P5 tolerance class
P6 Dimensional and running accuracy to P6 tolerance class
P62 P6 + C2
P63 P6 + C3
P64 P6 + C4
CNL Axial internal clearance in the lower half of the Normal range
C2 Axial internal clearance smaller than Normal
C2H Axial internal clearance in the upper half of the C2 range
C2L Axial internal clearance in the lower half of the C2 range
C3 Axial internal clearance greater than Normal
C4 Axial internal clearance greater than C3
CB Double row bearing with controlled axial clearance
CA Bearing for universal matching. Two bearings arranged back-to-back or face-to-face have axial internal clearance smaller than Normal (CB).
CB Bearing for universal matching. Two bearings arranged back-to-back or face-to-face have Normal axial internal clearance.
CC Bearing for universal matching. Two bearings arranged back-to-back or face-to-face have axial internal clearance greater than Normal (CB).
G Bearing for universal matching. Two bearings arranged back-to-back or face-to-face have axial internal clearance.
GA Bearing for universal matching. Two bearings arranged back-to-back or face-to-face have light preload.
GB Bearing for universal matching. Two bearings arranged back-to-back or face-to-face have moderate preload.
GC Bearing for universal matching. Two bearings arranged back-to-back or face-to-face have heavy preload.

Group 4.1: Materials, heat treatment

3.1 Single row angular contact ball bearings d 10–25 mm

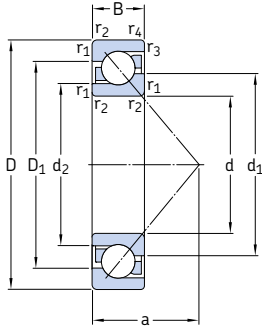

Principal dimensions			Basic load ratings		Fatigue load limit	Speed ratings		Mass	Designations ¹⁾	Basic design bearing
d	D	B	C	C ₀	P _u	Reference speed	Limiting speed		Universally matchable bearing	
mm			kN		kN	r/min		kg	–	
10	30	9	7,02	3,35	0,14	30 000	30 000	0,03	7200 BECBP	7200 BEP
12	32	10	7,61	3,8	0,16	26 000	26 000	0,036	7201 BECBP	7201 BEP
	37	12	10,6	5	0,208	24 000	24 000	0,06	–	7301 BEP
15	35	11	8,8	4,65	0,196	26 000	26 000	0,045	* 7202 BECBP	–
	35	11	8,32	4,4	0,183	24 000	24 000	0,045	–	7202 BEP
	42	13	13	6,7	0,28	20 000	20 000	0,08	7302 BECBP	7302 BEP
17	40	12	11	5,85	0,25	22 000	22 000	0,065	* 7203 BECBM	–
	40	12	11	5,85	0,25	22 000	22 000	0,065	* 7203 BECBP	–
	40	12	10,4	5,5	0,236	20 000	20 000	0,065	–	7203 BEP
	40	12	11,1	6,1	0,26	20 000	20 000	0,065	–	7203 BEY
	47	14	15,9	8,3	0,355	19 000	19 000	0,11	7303 BECBP	7303 BEP
20	47	14	14,3	8,15	0,345	19 000	19 000	0,11	* 7204 BECBM	–
	47	14	14,3	8,15	0,345	19 000	19 000	0,11	* 7204 BECBP	–
	47	14	14	8,3	0,355	18 000	18 000	0,11	7204 BECBY	–
	47	14	13,3	7,65	0,325	18 000	18 000	0,11	–	7204 BEP
	47	14	14,3	8,15	0,345	19 000	19 000	0,11	* 7204 BECBPH	–
	52	15	19	10	0,425	18 000	18 000	0,14	* 7304 BECBPH	–
	52	15	19	10	0,425	18 000	18 000	0,14	* 7304 BECBM	–
	52	15	19	10	0,425	18 000	18 000	0,14	* 7304 BECBP	–
	52	15	19	10,4	0,44	16 000	16 000	0,14	7304 BECBY	–
	52	15	17,4	9,5	0,4	16 000	16 000	0,14	–	7304 BEP
25	52	15	15,6	10	0,43	17 000	17 000	0,13	* 7205 BECBPH	–
	52	15	15,6	10	0,43	17 000	17 000	0,13	* 7205 BECBM	–
	52	15	15,6	10	0,43	17 000	17 000	0,13	* 7205 BECBP	–
	52	15	15,6	10,2	0,43	15 000	15 000	0,13	7205 BECBY	7205 BEY
	52	15	14,8	9,3	0,4	15 000	15 000	0,13	–	7205 BEP
	62	17	26,5	15,3	0,655	15 000	15 000	0,23	* 7305 BECBPH	–
	62	17	26,5	15,3	0,655	15 000	15 000	0,23	* 7305 BECBM	–
	62	17	26,5	15,3	0,655	15 000	15 000	0,23	* 7305 BECBP	–
	62	17	26	15,6	0,655	14 000	14 000	0,23	7305 BECBY	7305 BEY
	62	17	24,2	14	0,6	14 000	14 000	0,23	–	7305 BEP

¹⁾ For available final variants → matrix 1, page 500

* SKF Explorer bearing

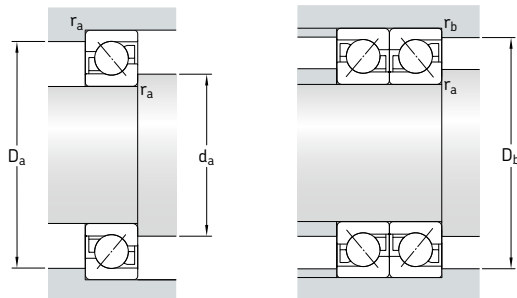

Dimensions

Abutment and fillet dimensions

d	d ₁ ~	d ₂ ~	D ₁ ~	r _{1,2} min.	r _{3,4} min.	a	d _a min.	D _a max.	D _b max.	r _a max.	r _b max.
mm							mm				
10	18,3	14,6	22,9	0,6	0,3	13	14,2	25,8	27,6	0,6	0,3
12	20,2 21,8	16,6 17	25 28,3	0,6 1	0,3 0,6	14 16,3	16,2 17,6	27,8 31,4	30 32,8	0,6 1	0,3 0,6
15	22,7 22,7 26	19 19 20,7	27,8 27,8 32,6	0,6 0,6 1	0,3 0,3 0,6	16 16 18,6	19,2 19,2 20,6	30,8 30,8 36	32,6 32,6 38	0,6 0,6 1	0,3 0,3 0,6
17	26,3 26,3 26,3 26,3 28,7	21,7 21,7 21,7 21,7 22,8	31,2 31,2 31,2 31,2 36,2	0,6 0,6 0,6 0,6 1	0,6 0,6 0,6 0,6 0,6	18 18 18 18 20,4	21,2 21,2 21,2 21,2 22,6	35,8 35,8 35,8 35,8 41,4	35,8 35,8 35,8 35,8 42,8	0,6 0,6 0,6 0,6 1	0,6 0,6 0,6 0,6 0,6
20	30,8 30,8 30,8 30,8 30,8	25,9 25,9 25,9 25,9 25,9	36,5 36,5 36,5 36,5 36,5	1 1 1 1 1	0,6 0,6 0,6 0,6 0,6	21 21 21 21 21	25,6 25,6 25,6 25,6 25,6	41,4 41,4 41,4 41,4 41,4	42,8 42,8 42,8 42,8 42,8	1 1 1 1 1	0,6 0,6 0,6 0,6 0,6
	33,3 33,3 33,3 33,3 33,3	33,3 33,3 33,3 33,3 33,3	40,4 40,4 40,4 40,4 40,4	1,1 1,1 1,1 1,1 1,1	0,6 0,6 0,6 0,6 0,6	22,8 22,8 22,8 22,8 22,8	27 27 27 27 27	45 45 45 45 45	47,8 47,8 47,8 47,8 47,8	1 1 1 1 1	0,6 0,6 0,6 0,6 0,6
25	36,1 36,1 36,1 36,1 36,1	30,9 30,9 30,9 30,9 30,9	41,5 41,5 41,5 41,5 41,5	1 1 1 1 1	0,6 0,6 0,6 0,6 0,6	24 24 24 24 24	30,6 30,6 30,6 30,6 30,6	46,4 46,4 46,4 46,4 46,4	47,8 47,8 47,8 47,8 47,8	1 1 1 1 1	0,6 0,6 0,6 0,6 0,6
	39,8 39,8 39,8 39,8 39,8	32,4 32,4 32,4 32,4 32,4	48,1 48,1 48,1 48,1 48,1	1,1 1,1 1,1 1,1 1,1	0,6 0,6 0,6 0,6 0,6	26,8 26,8 26,8 26,8 26,8	32 32 32 32 32	55 55 55 55 55	57,8 57,8 57,8 57,8 57,8	1 1 1 1 1	0,6 0,6 0,6 0,6 0,6

3.1 Single row angular contact ball bearings d 30–40 mm

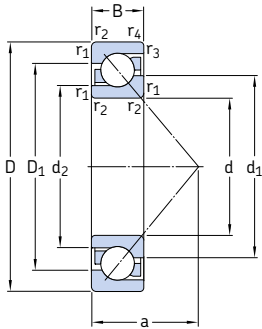

Principal dimensions			Basic load ratings		Fatigue load limit	Speed ratings		Mass	Designations ¹⁾	Basic design bearing
d	D	B	C	C ₀	P _u	Reference speed	Limiting speed	Universally matchable bearing		
mm			kN		kN	r/min		kg	–	
30	62	16	24	15,6	0,655	14 000	14 000	0,2	* 7206 BECBM	–
	62	16	24	15,6	0,655	14 000	14 000	0,2	* 7206 BECBP	–
	62	16	23,8	15,6	0,655	13 000	13 000	0,2	7206 BECBy	–
	62	16	22,5	14,3	0,61	13 000	13 000	0,2	–	7206 BEP
	62	16	24	15,6	0,655	14 000	14 000	0,2	* 7206 BECBPH	–
	72	19	35,5	21,2	0,9	13 000	13 000	0,34	* 7306 BECBM	–
	72	19	35,5	21,2	0,9	13 000	13 000	0,34	* 7306 BECBP	–
	72	19	34,5	21,2	0,9	12 000	12 000	0,34	7306 BECBy	–
	72	19	32,5	19,3	0,815	12 000	12 000	0,34	–	7306 BEP
	72	19	35,5	21,2	0,9	13 000	13 000	0,34	* 7306 BEGAPH	–
35	72	17	31	20,8	0,88	12 000	12 000	0,28	* 7207 BECBPH	–
	72	17	31	20,8	0,88	12 000	12 000	0,28	* 7207 BECBM	–
	72	17	31	20,8	0,88	12 000	12 000	0,28	* 7207 BECBP	–
	72	17	29,1	19	0,815	11 000	11 000	0,28	7207 BECBy	7207 BEP
	80	21	41,5	26,5	1,14	11 000	11 000	0,45	* 7307 BECBM	–
	80	21	41,5	26,5	1,14	11 000	11 000	0,45	* 7307 BECBP	–
	80	21	39	24,5	1,04	10 000	10 000	0,45	7307 BECBy	7307 BEP
	80	21	41,5	26,5	1,14	11 000	11 000	0,45	* 7307 BEGAPH	–
40	80	18	36,5	26	1,1	11 000	11 000	0,37	* 7208 BECBPH	–
	80	18	36,5	26	1,1	11 000	11 000	0,37	* 7208 BECBM	–
	80	18	36,5	26	1,1	11 000	11 000	0,37	* 7208 BECBP	–
	80	18	36,4	26	1,1	10 000	10 000	0,37	7208 BECBy	–
	80	18	37,7	26	1,1	11 000	11 000	0,37	–	7208 BEP
	90	23	50	32,5	1,37	10 000	10 000	0,68	* 7308 BECBM	–
	90	23	50	32,5	1,37	10 000	10 000	0,62	* 7308 BECBP	–
	90	23	49,4	33,5	1,4	9 000	9 000	0,64	7308 BECBy	–
	90	23	46,2	30,5	1,29	9 000	9 000	0,62	–	7308 BEP
	90	23	50	32,5	1,37	10 000	10 000	0,62	* 7308 BEGAPH	–

¹⁾ For available final variants → matrix 1, page 500

* SKF Explorer bearing

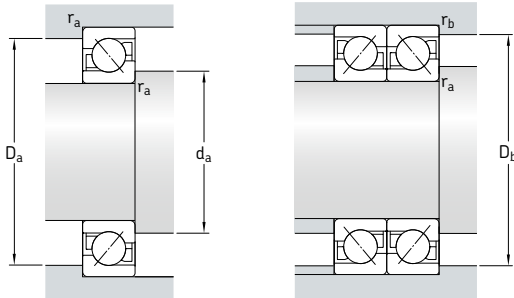

Dimensions

Abutment and fillet dimensions

d	d ₁ ~	d ₂ ~	D ₁ ~	r _{1,2} min.	r _{3,4} min.	a	d _a min.	D _a max.	D _b max.	r _a max.	r _b max.	
mm												
30	42,7	36,1	50,1	1	0,6	27,3	35,6	56,4	57,8	1	0,6	
	42,7	36,1	50,1	1	0,6	27,3	35,6	56,4	57,8	1	0,6	
	42,7	36,1	50,1	1	0,6	27,3	35,6	56,4	57,8	1	0,6	
	42,7	36,1	50,1	1	0,6	27,3	35,6	56,4	57,8	1	0,6	
	42,7	36,1	50,1	1	0,6	27,3	35,6	56,4	57,8	1	0,6	
	46,6	37,9	56,5	1,1	0,6	31	37	65	67,8	1	0,6	
	46,6	37,9	56,5	1,1	0,6	31	37	65	67,8	1	0,6	
	46,6	37,9	56,5	1,1	0,6	31	37	65	67,8	1	0,6	
	46,6	37,9	56,5	1,1	0,6	31	37	65	67,8	1	0,6	
	46,6	37,9	56,5	1,1	0,6	31	37	65	67,8	1	0,6	
35	49,7	42	58,3	1,1	0,6	31	42	65	67,8	1	0,6	
	49,7	42	58,3	1,1	0,6	31	42	65	67,8	1	0,6	
	49,7	42	58,3	1,1	0,6	31	42	65	67,8	1	0,6	
	49,7	42	58,3	1,1	0,6	31	42	65	67,8	1	0,6	
	52,8	43,6	63,3	1,5	1	35	44	71	74,4	1,5	1	
	52,8	43,6	63,3	1,5	1	35	44	71	74,4	1,5	1	
	52,8	43,6	63,3	1,5	1	35	44	71	74,4	1,5	1	
	52,8	43,6	63,3	1,5	1	35	44	71	74,4	1,5	1	
	40	56,3	48,1	65,6	1,1	0,6	34	47	73	75,8	1	0,6
		56,3	48,1	65,6	1,1	0,6	34	47	73	75,8	1	0,6
56,3		48,1	65,6	1,1	0,6	34	47	73	75,8	1	0,6	
56,3		48,1	65,6	1,1	0,6	34	47	73	75,8	1	0,6	
56,3		48,1	65,6	1,1	0,6	34	47	73	75,8	1	0,6	
59,7		49,6	71,6	1,5	1	39	49	81	84,4	1,5	1	
59,7		49,6	71,6	1,5	1	39	49	81	84,4	1,5	1	
59,7		49,6	71,6	1,5	1	39	49	81	84,4	1,5	1	
59,7		49,6	71,6	1,5	1	39	49	81	84,4	1,5	1	
59,7		49,6	71,6	1,5	1	39	49	81	84,4	1,5	1	

3.1 Single row angular contact ball bearings d 45–55 mm

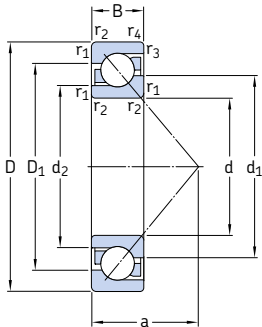

Principal dimensions			Basic load ratings		Fatigue load limit	Speed ratings		Mass	Designations ¹⁾	Basic design bearing	
d	D	B	C	C ₀	P _u	Reference speed	Limiting speed	Universally matchable bearing			
mm			kN		kN	r/min		kg	–		
45	85	19	38	28,5	1,22	10 000	10 000	0,42	* 7209 BECBM	–	
	85	19	38	28,5	1,22	10 000	10 000	0,42	* 7209 BECBP	–	
	85	19	37,7	28	1,2	9 000	9 000	0,42	7209 BECBy	–	
	85	19	35,8	26	1,12	9 000	9 000	0,42	–	7209 BEP	
	85	19	38	28,5	1,22	10 000	10 000	0,42	* 7209 BEGAPH	–	
	100	25	61	40,5	1,73	9 000	9 000	0,91	* 7309 BECBM	–	
	100	25	61	40,5	1,73	9 000	9 000	0,82	* 7309 BECBP	–	
	100	25	60,5	41,5	1,73	8 000	8 000	0,87	7309 BECBy	–	
	100	25	55,9	37,5	1,6	8 000	8 000	0,82	–	7309 BEP	
	100	25	61	40,5	1,73	9 000	9 000	0,82	* 7309 BEGAPH	–	
	50	90	20	40	31	1,32	9 000	9 000	0,47	* 7210 BECBPH	–
		90	20	40	31	1,32	9 000	9 000	0,47	* 7210 BECBM	–
90		20	40	31	1,32	9 000	9 000	0,47	* 7210 BECBP	–	
90		20	37,7	28,5	1,22	8 500	8 500	0,47	7210 BECBy	7210 BEP	
110		27	75	51	2,16	8 000	8 000	1,1	* 7310 BECBM	–	
110		27	75	51	2,16	8 000	8 000	1,1	* 7310 BECBP	–	
110		27	74,1	51	2,2	7 500	7 500	1,15	7310 BECBy	–	
110		27	68,9	47,5	2	7 500	7 500	1,1	–	7310 BEP	
110		27	75	51	2,16	8 000	8 000	1,1	* 7310 BEGAPH	–	
55	100	21	49	40	1,66	8 000	8 000	0,62	* 7211 BECBPH	–	
	100	21	49	40	1,66	8 000	8 000	0,62	* 7211 BECBM	–	
	100	21	49	40	1,66	8 000	8 000	0,62	* 7211 BECBP	–	
	100	21	48,8	38	1,63	7 500	7 500	0,62	7211 BECBy	–	
	100	21	46,2	36	1,53	7 500	7 500	0,62	–	7211 BEP	
	120	29	85	60	2,55	7 000	7 000	1,4	* 7311 BECBM	–	
	120	29	85	60	2,55	7 000	7 000	1,4	* 7311 BECBP	–	
	120	29	85,2	60	2,55	6 700	6 700	1,4	7311 BECBy	–	
	120	29	79,3	55	2,32	6 700	6 700	1,4	–	7311 BEP	
	120	29	85	60	2,55	7 000	7 000	1,4	* 7311 BEGAPH	–	

¹⁾ For available final variants → matrix 1, page 500

* SKF Explorer bearing

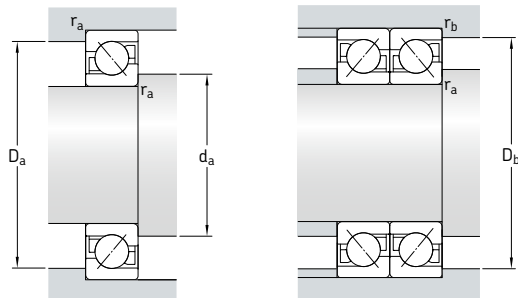

Dimensions

Abutment and fillet dimensions

d	d ₁ ~	d ₂ ~	D ₁ ~	r _{1,2} min.	r _{3,4} min.	a	d _a min.	D _a max.	D _b max.	r _a max.	r _b max.
mm											
mm											
45	60,9	52,7	70,2	1,1	0,6	37	52	78	80,8	1	0,6
	60,9	52,7	70,2	1,1	0,6	37	52	78	80,8	1	0,6
	60,9	52,7	70,2	1,1	0,6	37	52	78	80,8	1	0,6
	60,9	52,7	70,2	1,1	0,6	37	52	78	80,8	1	0,6
	60,9	52,7	70,2	1,1	0,6	37	52	78	80,8	1	0,6
	66,5	55,3	79,8	1,5	1	43	54	91	94,4	1,5	1
	66,5	55,3	79,8	1,5	1	43	54	91	94,4	1,5	1
	66,5	55,3	79,8	1,5	1	43	54	91	94,4	1,5	1
	66,5	55,3	79,8	1,5	1	43	54	91	94,4	1,5	1
	66,5	55,3	79,8	1,5	1	43	54	91	94,4	1,5	1
	66,5	55,3	79,8	1,5	1	43	54	91	94,4	1,5	1
	50	65,8	57,7	75,2	1,1	0,6	39	57	83	85,8	1
65,8		57,7	75,2	1,1	0,6	39	57	83	85,8	1	0,6
65,8		57,7	75,2	1,1	0,6	39	57	83	85,8	1	0,6
65,8		57,7	75,2	1,1	0,6	39	57	83	85,8	1	0,6
73,8		61,1	88,8	2	1	47	61	99	104	2	1
73,8		61,1	88,8	2	1	47	61	99	104	2	1
73,8		61,1	88,8	2	1	47	61	99	104	2	1
73,8		61,1	88,8	2	1	47	61	99	104	2	1
73,8		61,1	88,8	2	1	47	61	99	104	2	1
73,8		61,1	88,8	2	1	47	61	99	104	2	1
73,8		61,1	88,8	2	1	47	61	99	104	2	1
55		72,7	63,6	83,3	1,5	1	43	64	91	94	1,5
	72,7	63,6	83,3	1,5	1	43	64	91	94	1,5	1
	72,7	63,6	83,3	1,5	1	43	64	91	94	1,5	1
	72,7	63,6	83,3	1,5	1	43	64	91	94	1,5	1
	72,7	63,6	83,3	1,5	1	43	64	91	94	1,5	1
	72,7	63,6	83,3	1,5	1	43	64	91	94	1,5	1
	80,3	66,7	96,6	2	1	51	66	109	114	2	1
	80,3	66,7	96,6	2	1	51	66	109	114	2	1
	80,3	66,7	96,6	2	1	51	66	109	114	2	1
	80,3	66,7	96,6	2	1	51	66	109	114	2	1
	80,3	66,7	96,6	2	1	51	66	109	114	2	1

3.1 Single row angular contact ball bearings d 60–70 mm

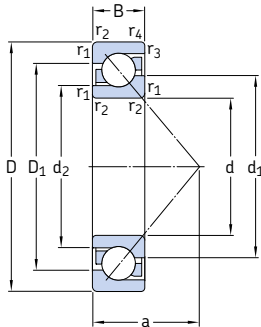

Principal dimensions			Basic load ratings		Fatigue load limit	Speed ratings		Mass	Designations ¹⁾	Basic design bearing
d	D	B	C	C ₀	P _u	Reference speed	Limiting speed	Universally matchable bearing		
mm			kN		kN	r/min		kg	–	
60	110	22	61	50	2,12	7 500	7 500	0,8	* 7212 BECBPH	–
	110	22	61	50	2,12	7 500	7 500	0,8	* 7212 BECBM	–
	110	22	61	50	2,12	7 500	7 500	0,8	* 7212 BECBP	–
	110	22	57,2	45,5	1,93	7 000	7 000	0,8	* 7212 BECBY	–
	110	22	57,2	45,5	1,93	7 000	7 000	0,8	–	7212 BEP
	130	31	104	76,5	3,2	6 700	6 700	1,75	* 7312 BECBM	–
	130	31	104	76,5	3,2	6 700	6 700	1,75	* 7312 BECBP	–
	130	31	104	76,5	3,2	6 700	6 700	1,75	* 7312 BECBPH	–
	130	31	95,6	69,5	3	6 000	6 000	1,75	7312 BECBY	7312 BEP
	65	120	23	69,5	57	2,45	6 700	6 700	1	* 7213 BECBM
120	23	69,5	57	2,45	6 700	6 700	1	* 7213 BECBP	–	
120	23	66,3	54	2,28	6 300	6 300	1	–	7213 BEP	
120	23	66,3	54	2,28	6 300	6 300	1	7213 BECBY	7213 BEY	
120	23	69,5	57	2,45	6 700	6 700	1	* 7213 BEGAPH	–	
70	140	33	116	86,5	3,65	6 300	6 300	2,15	* 7313 BECBM	–
	140	33	116	86,5	3,65	6 300	6 300	2,15	* 7313 BECBP	–
	140	33	108	80	3,35	5 600	5 600	2,15	7313 BECBY	7313 BEP
	140	33	116	86,5	3,65	6 300	6 300	2,15	* 7313 BECBPH	–
	125	24	72	60	2,55	6 300	6 300	1,1	* 7214 BECBM	–
125	24	72	60	2,55	6 300	6 300	1,1	* 7214 BECBP	–	
125	24	71,5	60	2,5	6 000	6 000	1,1	7214 BECBY	–	
125	24	72	60	2,55	6 300	6 300	1,1	* 7214 BECBPH	–	
125	24	67,6	56	2,36	6 000	6 000	1,1	–	7214 BEP	
150	150	35	127	98	3,9	5 600	5 600	2,65	* 7314 BECBM	–
	150	35	127	98	3,9	5 600	5 600	2,65	* 7314 BECBP	–
	150	35	127	98	3,9	5 600	5 600	2,65	* 7314 BECBPH	–
	150	35	119	90	3,65	5 300	5 300	2,65	7314 BECBY	7314 BEP
	150	35	127	98	3,9	5 600	5 600	2,65	* 7314 BEGAPH	–

¹⁾ For available final variants → matrix 1, page 500

* SKF Explorer bearing

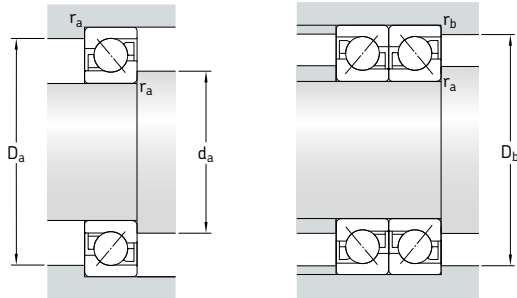

Dimensions

Abutment and fillet dimensions

d	d ₁ ~	d ₂ ~	D ₁ ~	r _{1,2} min.	r _{3,4} min.	a	d _a min.	D _a max.	D _b max.	r _a max.	r _b max.
mm							mm				
60	79,6	69,3	91,6	1,5	1	47	69	101	104	1,5	1
	79,6	69,3	91,6	1,5	1	47	69	101	104	1,5	1
	79,6	69,3	91,6	1,5	1	47	69	101	104	1,5	1
	79,6	69,3	91,6	1,5	1	47	69	101	104	1,5	1
	79,6	69,3	91,6	1,5	1	47	69	101	104	1,5	1
	87,3	72,6	105	2,1	1,1	55	72	118	123	2	1
	87,3	72,6	105	2,1	1,1	55	72	118	123	2	1
	87,3	72,6	105	2,1	1,1	55	72	118	123	2	1
	87,3	72,6	105	2,1	1,1	55	72	118	123	2	1
	87,3	72,6	105	2,1	1,1	55	72	118	123	2	1
65	86,4	75,5	100	1,5	1	50	74	111	114	1,5	1
	86,4	75,5	100	1,5	1	50	74	111	114	1,5	1
	86,4	75,5	100	1,5	1	50	74	111	114	1,5	1
	86,4	75,5	100	1,5	1	50	74	111	114	1,5	1
	86,4	75,5	100	1,5	1	50	74	111	114	1,5	1
	94,2	78,5	113	2,1	1,1	60	77	128	133	2	1
	94,2	78,5	113	2,1	1,1	60	77	128	133	2	1
	94,2	78,5	113	2,1	1,1	60	77	128	133	2	1
	94,2	78,5	113	2,1	1,1	60	77	128	133	2	1
	94,2	78,5	113	2,1	1,1	60	77	128	133	2	1
70	91,5	80,3	105	1,5	1	53	79	116	119	1,5	1
	91,5	80,3	105	1,5	1	53	79	116	119	1,5	1
	91,5	80,3	105	1,5	1	53	79	116	119	1,5	1
	91,5	80,3	105	1,5	1	53	79	116	119	1,5	1
	91,5	80,3	105	1,5	1	53	79	116	119	1,5	1
	101	84,4	121	2,1	1,1	64	82	138	143	2	1
	101	84,4	121	2,1	1,1	64	82	138	143	2	1
	101	84,4	121	2,1	1,1	64	82	138	143	2	1
	101	84,4	121	2,1	1,1	64	82	138	143	2	1
	101	84,4	121	2,1	1,1	64	82	138	143	2	1

3.1 Single row angular contact ball bearings d 75–85 mm

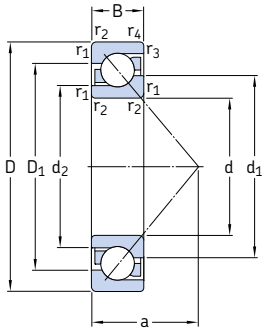

Principal dimensions			Basic load ratings		Fatigue load limit	Speed ratings		Mass	Designations ¹⁾	Basic design bearing
d	D	B	C	C ₀	P _u	Reference speed	Limiting speed	Universally matchable bearing		
mm			kN		kN	r/min		kg	–	
75	130	25	73,5	65,5	2,7	6 300	6 300	1,2	* 7215 BECBPH	–
	130	25	73,5	65,5	2,7	6 300	6 300	1,2	* 7215 BECBM	–
	130	25	73,5	65,5	2,7	6 300	6 300	1,2	* 7215 BECBP	–
	130	25	72,8	64	2,65	5 600	5 600	1,2	7215 BECBy	–
	130	25	70,2	60	2,5	5 600	5 600	1,2	–	7215 BEP
	160	37	132	104	4,15	5 300	5 300	3,2	* 7315 BECBM	–
	160	37	132	104	4,15	5 300	5 300	3,2	* 7315 BECBP	–
	160	37	133	106	4,15	5 000	5 000	3,2	7315 BECBy	–
	160	37	125	98	3,8	5 000	5 000	3,2	–	7315 BEP
	160	37	132	104	4,15	5 300	5 300	3,2	* 7315 BEGAPH	–
80	140	26	85	75	3,05	5 600	5 600	1,45	* 7216 BECBPH	–
	140	26	85	75	3,05	5 600	5 600	1,45	* 7216 BECBM	–
	140	26	85	75	3,05	5 600	5 600	1,45	* 7216 BECBP	–
	140	26	83,2	73,5	3	5 300	5 300	1,45	7216 BECBy	–
	140	26	80,6	69,5	2,8	5 300	5 300	1,45	–	7216 BEP
	140	26	85	75	3,05	5 600	5 600	1,45	* 7216 BEGAPH	–
	170	39	143	118	4,5	5 000	5 000	3,8	* 7316 BECBPH	–
	170	39	143	118	4,5	5 000	5 000	3,8	* 7316 BECBM	–
	170	39	143	118	4,5	5 000	5 000	3,8	* 7316 BECBP	–
	170	39	143	118	4,5	4 500	4 500	3,8	7316 BECBy	–
170	39	135	110	4,15	4 500	4 800	3,8	–	7316 BEM	
170	39	135	110	4,15	4 500	4 500	3,8	–	7316 BEP	
85	150	28	102	90	3,55	5 300	5 300	1,85	* 7217 BECBM	–
	150	28	102	90	3,55	5 300	5 300	1,85	* 7217 BECBP	–
	150	28	95,6	83	3,25	5 000	5 000	1,85	7217 BECBy	7217 BEP
	180	41	156	132	4,9	4 800	4 800	4,45	* 7317 BECBM	–
	180	41	156	132	4,9	4 800	4 800	4,45	* 7317 BECBP	–
	180	41	153	132	4,9	4 300	4 300	4,45	7317 BECBy	–
	180	41	146	122	4,5	4 300	4 500	4,45	–	7317 BEM
	180	41	146	122	4,5	4 300	4 300	4,45	–	7317 BEP
	180	41	156	132	4,9	4 800	4 800	4,45	* 7317 BEGAPH	–

¹⁾ For available final variants → matrix 1, page 500

* SKF Explorer bearing

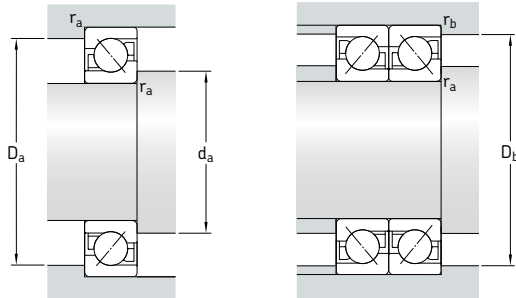

Dimensions

Abutment and fillet dimensions

d	d ₁ ~	d ₂ ~	D ₁ ~	r _{1,2} min.	r _{3,4} min.	a	d _a min.	D _a max.	D _b max.	r _a max.	r _b max.
mm							mm				
75	96,3	85,3	111	1,5	1	56	84	121	124	1,5	1
	96,3	85,3	111	1,5	1	56	84	121	124	1,5	1
	96,3	85,3	111	1,5	1	56	84	121	124	1,5	1
	96,3	85,3	111	1,5	1	56	84	121	124	1,5	1
	96,3	85,3	111	1,5	1	56	84	121	124	1,5	1
	108	91,1	129	2,1	1,1	68	87	148	153	2	1
	108	91,1	129	2,1	1,1	68	87	148	153	2	1
	108	91,1	129	2,1	1,1	68	87	148	153	2	1
	108	91,1	129	2,1	1,1	68	87	148	153	2	1
	108	91,1	129	2,1	1,1	68	87	148	153	2	1
80	103	91,4	118	2	1	59	91	130	134	2	1
	103	91,4	118	2	1	59	91	130	134	2	1
	103	91,4	118	2	1	59	91	130	134	2	1
	103	91,4	118	2	1	59	91	130	134	2	1
	103	91,4	118	2	1	59	91	130	134	2	1
	103	91,4	118	2	1	59	91	130	134	2	1
	103	91,4	118	2	1	59	91	130	134	2	1
	103	91,4	118	2	1	59	91	130	134	2	1
	115	97,1	137	2,1	1,1	72	92	158	163	2	1
	115	97,1	137	2,1	1,1	72	92	158	163	2	1
85	110	97	127	2	1	63	96	139	144	2	1
	110	97	127	2	1	63	96	139	144	2	1
	110	97	127	2	1	63	96	139	144	2	1
	122	103	145	3	1,1	76	99	166	173	2,5	1
	122	103	145	3	1,1	76	99	166	173	2,5	1
	122	103	145	3	1,1	76	99	166	173	2,5	1
	122	103	145	3	1,1	76	99	166	173	2,5	1
	122	103	145	3	1,1	76	99	166	173	2,5	1
	122	103	145	3	1,1	76	99	166	173	2,5	1

3.1 Single row angular contact ball bearings d 90–105 mm

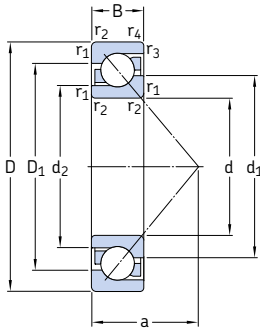

Principal dimensions			Basic load ratings		Fatigue load limit	Speed ratings		Mass	Designations ¹⁾	Basic design bearing	
d	D	B	C	C ₀	P _u	Reference speed	Limiting speed	Universally matchable bearing			
mm			kN		kN	r/min		kg	–		
90	160	30	116	104	4	5 000	5 000	2,3	* 7218 BECBM	–	
	160	30	116	104	4	5 000	5 000	2,3	* 7218 BECBP	–	
	160	30	108	96,5	3,65	4 500	4 500	2,3	7218 BECBy	7218 BEP	
	190	43	166	146	5,3	4 500	4 500	5,2	* 7318 BEGAPH	–	
	190	43	166	146	5,3	4 500	4 500	5,2	* 7318 BECBM	–	
	190	43	166	146	5,3	4 500	4 500	5,2	* 7318 BECBP	–	
	190	43	165	146	5,2	4 000	4 000	5,2	7318 BECBy	–	
	190	43	156	134	4,8	4 000	4 300	5,2	–	7318 BEM	
	190	43	156	134	4,8	4 000	4 000	5,2	–	7318 BEP	
	95	170	32	124	108	4	4 300	4 500	2,7	7219 BECBM	–
170		32	129	118	4,4	4 800	4 800	2,7	* 7219 BECBP	–	
170		32	124	108	4	4 300	4 300	2,7	7219 BECBy	7219 BEP	
170		32	129	118	4,4	4 800	4 800	2,7	* 7219 BEGAPH	–	
200		45	180	163	5,7	4 300	4 300	6,05	* 7319 BECBM	–	
200		45	180	163	5,7	4 300	4 300	6,05	* 7319 BECBP	–	
200		45	190	176	6,1	4 300	4 300	6,05	7319 BECBy	–	
200		45	168	150	5,2	3 800	4 000	6,05	–	7319 BEM	
200		45	168	150	5,2	3 800	3 800	6,05	–	7319 BEP	
100		180	34	143	134	4,75	4 500	4 500	3,3	* 7220 BECBM	–
	180	34	143	134	4,75	4 500	4 500	3,3	* 7220 BECBP	–	
	180	34	135	122	4,4	4 000	4 000	3,3	7220 BECBy	7220 BEP	
	215	47	216	208	6,95	4 000	4 000	7,5	* 7320 BECBM	–	
	215	47	216	208	6,95	4 000	4 000	7,5	* 7320 BECBP	–	
	215	47	203	190	6,4	3 600	3 600	7,5	7320 BECBy	7320 BEP	
	215	47	203	190	6,4	3 600	3 600	7,5	–	7320 BEM	
	105	190	36	156	150	5,2	4 300	4 300	3,95	* 7221 BECBM	–
		190	36	156	150	5,2	4 300	4 300	3,95	* 7221 BECBP	–
		225	49	216	208	6,95	3 800	3 800	8,55	* 7321 BECBM	–
225		49	216	208	6,95	3 800	3 800	8,55	* 7321 BECBP	–	
225		49	203	193	6,4	3 400	3 400	8,55	–	7321 BEP	

¹⁾ For available final variants → matrix 1, page 500

* SKF Explorer bearing

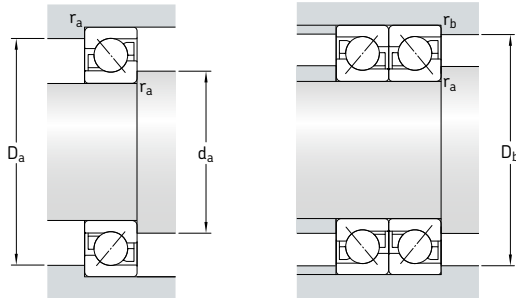

Dimensions

Abutment and fillet dimensions

d	d ₁ ~	d ₂ ~	D ₁ ~	r _{1,2} min.	r _{3,4} min.	a	d _a min.	D _a max.	D _b max.	r _a max.	r _b max.
mm							mm				
90	117	103	135	2	1	67	101	149	154	2	1
	117	103	135	2	1	67	101	149	154	2	1
	117	103	135	2	1	67	101	149	154	2	1
	129	109	154	3	1,1	80	104	176	183	2,5	1
	129	109	154	3	1,1	80	104	176	183	2,5	1
	129	109	154	3	1,1	80	104	176	183	2,5	1
	129	109	154	3	1,1	80	104	176	183	2,5	1
95	124	109	143	2,1	1,1	72	107	158	163	2	1
	124	109	143	2,1	1,1	72	107	158	163	2	1
	124	109	143	2,1	1,1	72	107	158	163	2	1
	124	109	143	2,1	1,1	72	107	158	163	2	1
	136	114	162	3	1,1	84	109	186	193	2,5	1
	136	114	162	3	1,1	84	109	186	193	2,5	1
	136	114	162	3	1,1	84	109	186	193	2,5	1
100	131	115	151	2,1	1,1	76	112	168	173	2	1
	131	115	151	2,1	1,1	76	112	168	173	2	1
	131	115	151	2,1	1,1	76	112	168	173	2	1
	144	120	174	3	1,1	90	114	201	208	2,5	1
	144	120	174	3	1,1	90	114	201	208	2,5	1
	144	120	174	3	1,1	90	114	201	208	2,5	1
	144	120	174	3	1,1	90	114	201	208	2,5	1
105	138	121	160	2,1	1,1	80	117	178	183	2	1
	138	121	160	2,1	1,1	80	117	178	183	2	1
	151	127	182	3	1,1	94	119	211	218	2,5	1
	151	127	182	3	1,1	94	119	211	218	2,5	1
	151	127	182	3	1,1	94	119	211	218	2,5	1

3.1 Single row angular contact ball bearings d 110–190 mm

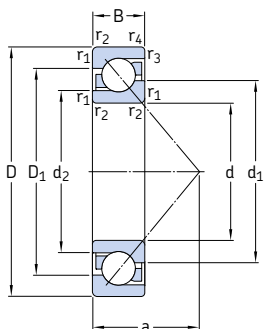

Principal dimensions			Basic load ratings		Fatigue load limit	Speed ratings		Mass	Designations ¹⁾	Basic design bearing
d	D	B	C	C ₀	P _u	Reference speed	Limiting speed		Universally matchable bearing	
mm			kN		kN	r/min		kg	–	
110	200	38	163	156	5,3	4 000	4 000	4,6	* 7222 BECBM	–
	200	38	170	166	5,7	4 000	4 000	4,6	* 7222 BECBP	–
	200	38	163	153	5,2	3 600	3 600	4,6	7222 BECBy	7222 BEP
	240	50	240	245	7,8	3 600	3 600	10	* 7322 BECBM	–
	240	50	240	245	7,8	3 600	3 600	10	* 7322 BECBP	–
	240	50	225	224	7,2	3 200	3 200	10	7322 BECBy	7322 BEY
120	240	50	225	224	7,2	3 200	3 400	10	–	7322 BEM
	180	28	87,1	93	3,2	3 800	4 000	2,4	7024 BGM	–
	215	40	165	163	5,3	3 400	3 600	5,9	7224 BCBM	7224 BM
130	260	55	238	250	7,65	3 000	3 000	14,5	7324 BCBM	–
	230	40	186	193	6,1	3 200	3 400	6,95	7226 BCBM	7226 BM
140	280	58	276	305	9	2 800	2 800	17	7326 BCBM	7326 BM
	210	33	114	129	4,15	3 200	3 400	3,85	7028 BGM	–
	250	42	199	212	6,4	3 000	3 000	8,85	7228 BCBM	7228 BM
150	300	62	302	345	9,8	2 600	2 600	21,5	7328 BCBM	–
	225	35	133	146	4,55	3 000	3 200	4,7	7030 BGM	–
	270	45	216	240	6,95	2 600	2 800	11,5	7230 BCBM	–
160	320	65	332	390	10,8	2 400	2 400	26	7330 BCBM	–
	290	48	255	300	8,5	2 400	2 600	14	7232 BCBM	–
	260	42	172	204	5,85	2 600	2 800	7,65	7034 BGM	–
170	310	52	281	345	9,5	2 400	2 400	17,5	7234 BCBM	–
	360	72	390	490	12,7	2 000	2 200	36	7334 BCBM	–
	280	46	195	240	6,7	2 400	2 600	10	7036 BGM	–
180	320	52	291	375	10	2 200	2 400	18	7236 BCBM	–
	380	75	410	540	13,7	2 000	2 000	42	7336 BCBM	–
	290	46	199	255	6,95	2 400	2 400	10,5	7038 BGM	–
190	340	55	307	405	10,4	2 000	2 200	22	7238 BCBM	–
	400	78	442	600	14,6	1 900	2 000	48,5	7338 BCBM	–

¹⁾ For available final variants → matrix 1, page 500

* SKF Explorer bearing

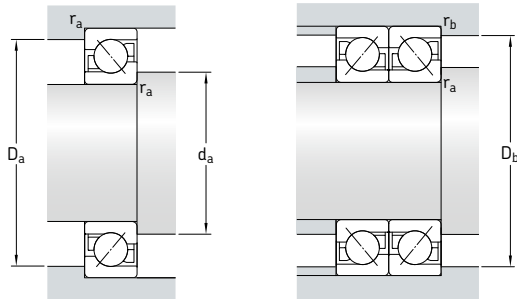

Dimensions

Abutment and fillet dimensions

d	d ₁ ~	d ₂ ~	D ₁ ~	r _{1,2} min.	r _{3,4} min.	a	d _a min.	D _a max.	D _b max.	r _a max.	r _b max.
mm							mm				
110	144	127	168	2,1	1,1	84	122	188	193	2	1
	144	127	168	2,1	1,1	84	122	188	193	2	1
	144	127	168	2,1	1,1	84	122	188	193	2	1
	160	135	194	3	1,1	99	124	226	233	2,5	1
	160	135	194	3	1,1	99	124	226	233	2,5	1
	160	135	194	3	1,1	99	124	226	233	2,5	1
120	143	132	158	2	1	77	130	170	174	2	1
	157	138	180	2,1	1,1	90	132	203	208	2	1
	178	153	211	3	1,5	107	134	246	253	2,5	1
130	169	149	193	3	1,1	96	144	216	222	2,5	1
	189	161	228	4	1,5	115	147	263	271	3	1,5
140	168	155	183	2	1	90	150	200	204	2	1
	183	163	210	3	1,1	103	154	236	243	2,5	1
	203	172	243	4	1,5	123	158	283	291	3	1,5
150	178	166	197	2,1	1,1	96	162	213	218	2	1
	197	175	226	3	1,1	111	164	256	263	2,5	1
	216	183	259	4	1,5	131	167	303	311	3	1,5
160	211	187	243	3	1,1	118	174	276	283	2,5	1
170	205	188	226	2,1	1,1	111	182	248	253	2	1
	227	202	261	4	1,5	127	187	293	301	3	1,5
	243	207	292	4	2	147	187	343	351	3	2
180	219	201	243	2,1	1,1	119	192	268	273	2	1
	234	209	269	4	1,5	131	197	303	311	3	1,5
	257	219	308	4	2	156	197	363	370	3	2
190	229	210	253	2,1	1,1	124	202	278	283	2	1
	250	224	286	4	1,5	139	207	323	331	3	1,5
	271	231	325	5	2	164	210	380	390	4	2

3.1 Single row angular contact ball bearings d 200–320 mm

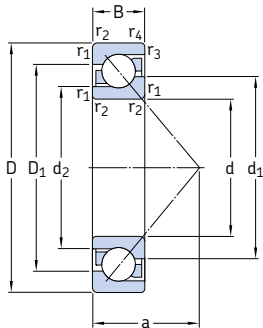

Principal dimensions			Basic load ratings		Fatigue load limit P_u	Speed ratings		Mass	Designation ¹⁾ Universally matchable bearing
d	D	B	dynamic C	static C_0		Reference speed	Limiting speed		
mm			kN		kN	r/min		kg	–
200	310	51	225	290	7,8	2 200	2 200	18	7040 BGM
	360	58	325	430	11	2 000	2 000	25	7240 BCBM
	420	80	462	655	15,6	1 800	1 800	53	7340 BCBM
220	340	56	255	355	9	2 000	2 000	18	7044 BGM
	400	65	390	560	13,4	1 800	1 800	37	7244 BCBM
240	360	56	260	375	9,15	1 800	1 900	19	7048 BGM
	440	72	364	540	12,5	1 600	1 700	49	7248 BCBM
260	400	65	332	510	11,8	1 600	1 700	30	7052 BGM
280	420	65	338	540	12,2	1 500	1 600	30	7056 BGM
300	540	65	553	930	19,3	850	1 300	86,5	7260 BCBM
320	580	92	572	1 020	20,4	850	1 200	110	7264 BCBM

¹⁾ For available final variants → matrix 1, page 500

* SKF Explorer bearing

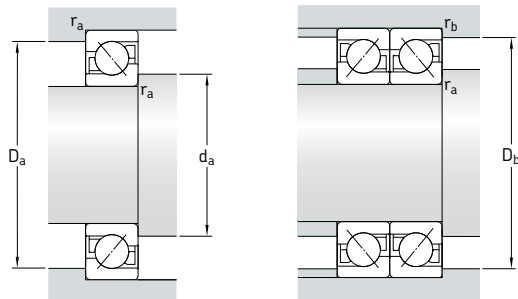

Dimensions

Abutment and fillet dimensions

d	d ₁ ~	d ₂ ~	D ₁ ~	r _{1,2} min.	r _{3,4} min.	a	d _a min.	D _a max.	D _b max.	r _a max.	r _b max.
mm							mm				
200	243	223	269	2,1	1,1	145	234	285	333	2,1	1,1
	263	235	301	4	1,5	146	217	343	351	3	1,5
	287	247	340	5	2	170	220	400	410	4	2
220	266	246	295	3	1,1	145	234	326	333	2,5	1,1
	291	259	334	4	1,5	164	237	383	391	3	1,5
240	286	265	315	3	1,1	154	254	346	353	2,5	1,1
	322	292	361	4	1,5	180	257	423	431	3	1,5
260	314	288	348	4	1,5	171	276	373	380	3	1,5
280	335	311	367	4	1,5	179	298	402	411	3	1,5
300	395	351	450	5	2,1	219	322	518	528	4	2
320	427	383	487	5	2	236	342	558	568	4	2

3.2 Double row angular contact ball bearings d 10–50 mm

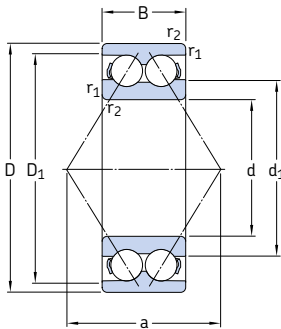

32..A, 33..A

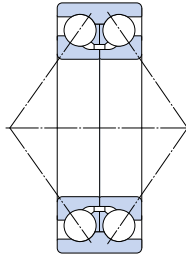

33..D

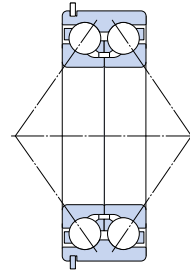

33..DNRCBM¹⁾

Principal dimensions			Basic load ratings		Fatigue load limit	Speed ratings		Mass	Designations ²⁾	
d	D	B	C	C ₀	P _u	Reference speed	Limiting speed		Bearing with metal cage	polyamide cage
mm			kN		kN	r/min		kg	–	
10	30	14	7,61	4,3	0,183	22 000	24 000	0,051	–	3200 ATN9
12	32	15,9	10,1	5,6	0,24	20 000	22 000	0,058	–	3201 ATN9
15	35	15,9	11,2	6,8	0,285	17 000	18 000	0,066	–	3202 ATN9
	42	19	15,1	9,3	0,4	15 000	16 000	0,13	–	3302 ATN9
17	40	17,5	14,3	8,8	0,365	15 000	16 000	0,096	–	3203 ATN9
	47	22,2	21,6	12,7	0,54	14 000	14 000	0,18	–	3303 ATN9
20	47	20,6	20	12	0,51	14 000	14 000	0,16	* 3204 A	* 3204 ATN9
	52	22,2	23,6	14,6	0,62	13 000	13 000	0,22	* 3304 A	* 3304 ATN9
25	52	20,6	21,6	14,3	0,6	12 000	12 000	0,18	* 3205 A	* 3205 ATN9
	62	25,4	32	20,4	0,865	11 000	11 000	0,35	* 3305 A	* 3305 ATN9
30	62	23,8	30	20,4	0,865	10 000	10 000	0,29	* 3206 A	* 3206 ATN9
	72	30,2	41,5	27,5	1,16	9 000	9 000	0,52	* 3306 A	* 3306 ATN9
35	72	27	40	28	1,18	9 000	9 000	0,44	* 3207 A	* 3207 ATN9
	80	34,9	52	35,5	1,5	8 500	8 500	0,74	* 3307 A	* 3307 ATN9
	80	34,9	52,7	41,5	1,76	7 500	8 000	0,79	3307 DJ1	–
40	80	30,2	47,5	34	1,43	8 000	8 000	0,57	* 3208 A	* 3208 ATN9
	90	36,5	64	44	1,86	7 500	7 500	0,93	* 3308 A	* 3308 ATN9
	90	36,5	49,4	41,5	1,76	6 700	7 000	1,2	3308 DNRCBM	–
	90	36,5	68,9	57	2,45	6 700	7 000	1,05	3308 DMA	3308 DTN9
45	85	30,2	51	39	1,63	7 500	7 500	0,63	* 3209 A	* 3209 ATN9
	100	39,7	75	53	2,24	6 700	6 700	1,25	* 3309 A	* 3309 ATN9
	100	39,7	61,8	52	2,2	6 000	6 300	1,5	3309 DNRCBM	–
	100	39,7	79,3	69,5	3	6 000	6 300	1,65	3309 DMA	–
50	90	30,2	51	39	1,66	7 000	7 000	0,65	* 3210 A	* 3210 ATN9
	110	44,4	90	64	2,75	6 000	6 000	1,7	* 3310 A	* 3310 ATN9
	110	44,4	81,9	69,5	3	5 300	5 600	1,95	3310 DNRCBM	–
	110	44,4	93,6	85	3,6	5 300	5 600	2,2	3310 DMA	–

¹⁾ For dimensions of snap ring groove and snap ring → table 4, page 488

²⁾ For available final variants → matrix 2, page 501

* SKF Explorer bearing

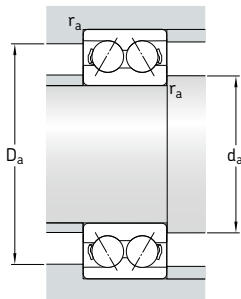

Dimensions

Abutment and fillet dimensions

d	d ₁ ~	D ₁ ~	r _{1,2} min.	a	d _a min.	D _a max.	r _a max.
					mm		
10	15,8	25	0,6	16	14,4	25,6	0,6
12	17,2	27,7	0,6	19	16,4	27,6	0,6
15	20,2	30,7	0,6	21	19,4	30,6	0,6
	23,7	35,7	1	24	20,6	36,4	1
17	23,3	35	0,6	23	21,4	35,6	0,6
	27,3	38,8	1	28	22,6	41,4	1
20	27,7	40,9	1	28	25,6	41,4	1
	29,9	44	1,1	30	27	45	1
25	32,7	45,9	1	30	31	46	1
	35,7	53,4	1,1	36	32	55	1
30	38,7	55,2	1	36	36	56	1
	39,8	64,1	1,1	42	37	65	1
35	45,4	63,9	1,1	42	42	65	1
	44,6	70,5	1,5	47	44	71	1,5
	52,8	69	1,5	76	44	71	1,5
40	47,8	72,1	1,1	46	47	73	1
	50,8	80,5	1,5	53	49	81	1,5
	60,1	79,5	1,5	71	49	81	1,5
	59,4	80,3	1,5	84	49	81	1,5
45	52,8	77,1	1,1	46	52	78	1
	55,6	90	1,5	58	54	91	1,5
	68	87,1	1,5	79	54	91	1,5
	70	86,4	1,5	93	54	91	1,5
50	57,8	82,1	1,1	52	57	83	1
	62	99,5	2	65	61	99,5	2
	74,6	87	2	102	61	99	2
	76,5	94,2	2	102	61	99	2

3.2 Double row angular contact ball bearings d 55–110 mm

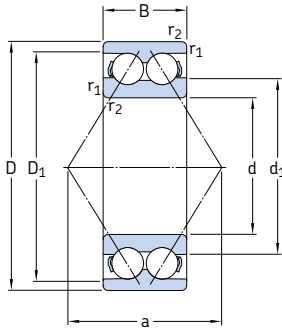

32..A, 33..A

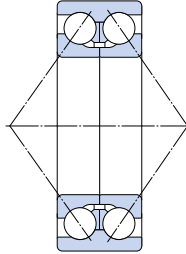

33..D

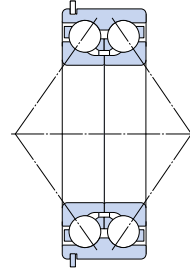

33..DNRCBM¹⁾

Principal dimensions			Basic load ratings		Fatigue load limit	Speed ratings		Mass	Designations ²⁾	
d	D	B	C	C ₀	P _u	Reference speed	Limiting speed	kg	Bearing with metal cage	polyamide cage
mm			kN		kN	r/min		kg	-	
55	100	33,3	60	47,5	2	6 300	6 300	0,91	* 3211 A	* 3211 ATN9
	120	49,2	112	81,5	3,45	5 300	5 300	2,65	* 3311 A	* 3311 ATN9
	120	49,2	95,6	83	3,55	5 000	5 300	2,55	3311 DNRCBM	-
	120	49,2	111	100	4,3	4 800	5 000	2,8	3311 DMA	-
60	110	36,5	73,5	58,5	2,5	5 600	5 600	1,2	* 3212 A	* 3212 ATN9
	130	54	127	95	4,05	5 000	5 000	2,8	* 3312 A	-
65	120	38,1	80,6	73,5	3,1	4 500	4 800	1,75	3213 A	-
	140	58,7	146	110	4,55	4 500	4 500	4,1	* 3313 A	-
	140	58,7	138	122	5,1	4 300	4 500	4	3313 DNRCBM	-
70	125	39,7	88,4	80	3,4	4 300	4 500	1,9	3214 A	-
	150	63,5	163	125	5	4 300	4 300	5,05	* 3314 A	-
75	130	41,3	95,6	88	3,75	4 300	4 500	2,1	3215 A	-
	160	68,3	176	140	5,5	4 000	4 000	5,55	* 3315 A	-
80	140	44,4	106	95	3,9	4 000	4 300	2,65	3216 A	-
	170	68,3	193	156	6	3 800	3 800	6,8	* 3316 A	-
85	150	49,2	124	110	4,4	3 600	3 800	3,4	3217 A	-
	180	73	208	176	6,55	3 600	3 600	8,3	* 3317 A	-
90	160	52,4	130	120	4,55	3 400	3 600	4,15	3218 A	-
	190	73	208	180	6,4	3 400	3 400	9,25	* 3318 A	-
95	170	55,6	159	146	5,4	3 200	3 400	5	3219 A	-
	200	77,8	240	216	7,5	3 200	3 200	11	* 3319 A	-
100	180	60,3	178	166	6	3 000	3 200	6,1	3220 A	-
	215	82,6	255	255	8,65	2 600	2 800	13,5	3320 A	-
110	200	69,8	212	212	7,2	2 800	2 800	8,8	3222 A	-
	240	92,1	291	305	9,8	2 400	2 600	19	3322 A	-

¹⁾ For dimensions of snap ring groove and snap ring → table 4, page 488

²⁾ For available final variants → matrix 2, page 501

* SKF Explorer bearing

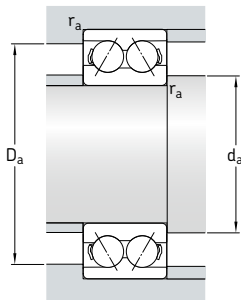

Dimensions

Abutment and fillet dimensions

d	d ₁ ~	D ₁ ~	r _{1,2} min.	a	d _a min.	D _a max.	r _a max.
mm					mm		
55	63,2	92,3	1,5	57	63	91	1,5
	68,4	109	2	72	66	109	2
	81,6	107	2	97	66	109	2
	81,3	105	2	114	66	109	2
60	68,8	101	1,5	63	69	101	1,5
	74,3	118	2,1	78	72	118	2
65	85	103	1,5	71	74	111	1,5
	78,5	116	2,1	84	77	128	2
	95,1	126	2,1	114	77	128	2
70	88,5	107	1,5	74	79	116	1,5
	84,2	125	2,1	89	82	138	2
75	91,9	112	1,5	77	84	121	1,5
	88,8	135	2,1	97	87	148	2
80	97,7	120	2	82	91	129	2
	108	143	2,1	101	92	158	2
85	104	128	2	88	96	139	2
	116	153	3	107	99	166	2,5
90	111	139	2	94	101	149	2
	123	160	3	112	104	176	2,5
95	119	147	2,1	101	107	158	2
	127	168	3	127	109	186	2,5
100	125	155	2,1	107	112	168	2
	136	180	3	127	114	201	2,5
110	139	173	2,1	119	122	188	2
	153	200	3	142	124	226	2,5

3.3 Capped double row angular contact ball bearings d 10–40 mm

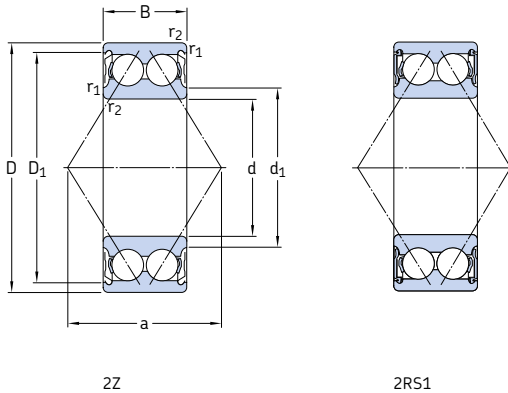

Principal dimensions			Basic load ratings		Fatigue load limit	Limiting speed		Mass	Designations ¹⁾	
d	D	B	dynamic	static		Bearing with shields	seals		Bearing with shields	seals
mm			kN		kN	r/min		kg	–	
10	30	14,3	7,61	4,3	0,183	24 000	17 000	0,051	3200 A-2Z	3200 A-2RS1
12	32	15,9	10,1	5,6	0,24	22 000	15 000	0,058	3201 A-2Z	3201 A-2RS1
15	35	15,9	11,2	6,8	0,285	18 000	14 000	0,066	3202 A-2Z	3202 A-2RS1
	42	19	15,1	9,3	0,4	16 000	12 000	0,13	3302 A-2Z	3302 A-2RS1
17	40	17,5	14,3	8,8	0,365	16 000	12 000	0,1	3203 A-2Z	3203 A-2RS1
	47	22,2	21,6	12,7	0,54	14 000	11 000	0,18	3303 A-2Z	3303 A-2RS1
20	47	20,6	20	12	0,51	14 000	–	0,16	E2.3204 A-2Z	–
	47	20,6	20	12	0,51	14 000	10 000	0,16	* 3204 A-2Z	* 3204 A-2RS1
	52	22,2	23,6	14,6	0,62	13 000	–	0,22	E2.3304 A-2Z	–
	52	22,2	23,6	14,6	0,62	13 000	9 000	0,22	* 3304 A-2Z	* 3304 A-2RS1
25	52	20,6	21,6	14,3	0,6	12 000	–	0,18	E2.3205 A-2Z	–
	52	20,6	21,6	14,3	0,6	12 000	8 500	0,18	* 3205 A-2Z	* 3205 A-2RS1
	62	25,4	32	20,4	0,865	11 000	–	0,35	E2.3305 A-2Z	–
	62	25,4	32	20,4	0,865	11 000	7 500	0,35	* 3305 A-2Z	* 3305 A-2RS1
30	62	23,8	30	20,4	0,865	10 000	–	0,29	E2.3206 A-2Z	–
	62	23,8	28,6	20,4	0,865	10 000	7 500	0,29	* 3206 A-2Z	* 3206 A-2RS1
	72	30,2	41,5	27,5	1,16	9 000	–	0,52	E2.3306 A-2Z	–
	72	30,2	41,5	27,5	1,16	9 000	6 300	0,52	* 3306 A-2Z	* 3306 A-2RS1
35	72	27	40	28	1,18	9 000	–	0,44	E2.3207 A-2Z	–
	72	27	40	28	1,18	9 000	6 300	0,44	* 3207 A-2Z	* 3207 A-2RS1
	80	34,9	52	35,5	1,5	8 500	–	0,74	E2.3307 A-2Z	–
	80	34,9	52	35,5	1,5	8 500	6 000	0,74	* 3307 A-2Z	* 3307 A-2RS1
40	80	30,2	47,5	34	1,43	8 000	–	0,57	E2.3208 A-2Z	–
	80	30,2	47,5	34	1,43	8 000	5 600	0,57	* 3208 A-2Z	* 3208 A-2RS1
	90	36,5	64	44	1,86	7 500	–	0,93	E2.3308 A-2Z	–
	90	36,5	64	44	1,86	7 500	5 000	0,93	* 3308 A-2Z	* 3308 A-2RS1

¹⁾ For available final variants → matrix 2, page 501

* SKF Explorer bearing

E2 → SKF Energy Efficient bearing

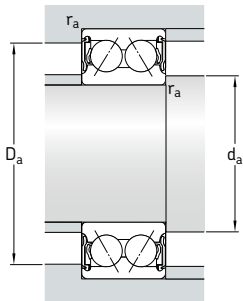

Dimensions

Abutment and fillet dimensions

d	d_1 ~	D_1 ~	$r_{1,2}$ min.	a	d_a min.	d_a max.	D_a max.	r_a max.
mm					mm			
10	15,8	25	0,6	16	14,4	15,5	25,6	0,6
12	17,2	27,7	0,6	19	16,4	17	27,6	0,6
15	20,2 23,7	30,7 35,7	0,6 1	21 24	19,4 20,6	20 23,5	30,6 36,4	0,6 1
17	23,3 27,3	35 38,8	0,6 1	23 28	21,4 22,6	23 25,5	35,6 41,4	0,6 1
20	27,7 27,7 29,9 29,9	40,9 40,9 44 44	1 1 1,1 1,1	28 28 30 30	25,6 25,6 27 27	27,5 27,5 29,5 29,5	41,4 41,4 45 45	1 1 1 1
25	32,7 32,7 35,7 35,7	45,9 45,9 53,4 53,4	1 1 1,1 1,1	30 30 36 36	30,6 30,6 32 32	32,5 32,5 35,5 35,5	46,4 46,4 55 55	1 1 1 1
30	38,7 38,7 39,8 39,8	55,2 55,2 64,1 64,1	1 1 1,1 1,1	36 36 42 42	35,6 35,6 37 37	38,5 38,5 39,5 39,5	56,4 56,4 65 65	1 1 1 1
35	45,4 45,4 44,6 44,6	63,9 63,9 70,5 70,5	1,1 1,1 1,5 1,5	42 42 47 47	42 42 44 44	45 45 44,5 44,5	65 65 71 71	1 1 1,5 1,5
40	47,8 47,8 50,8 50,8	72,1 72,1 80,5 80,5	1,1 1,1 1,5 1,5	46 46 53 53	47 47 49 49	48 48 50,5 50,5	73 73 81 81	1 1 1,5 1,5

3.3 Capped double row angular contact ball bearings d 45–75 mm

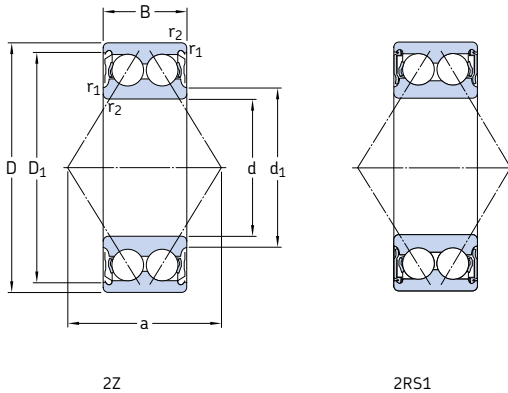

Principal dimensions			Basic load ratings		Fatigue load limit	Limiting speed		Mass	Designations ¹⁾	
d	D	B	dynamic	static		Bearing with shields	Bearing with seals		Bearing with shields	seals
mm			kN		kN	r/min		kg	–	
45	85	30,2	51	39	1,63	7 500	–	0,63	E2.3209 A-2Z	–
	85	30,2	51	39	1,63	7 500	5 300	0,63	* 3209 A-2Z	* 3209 A-2RS1
	100	39,7	75	53	2,24	6 700	–	1,25	E2.3309 A-2Z	–
	100	39,7	75	53	2,24	6 700	4 800	1,25	* 3309 A-2Z	* 3309 A-2RS1
50	90	30,2	51	39	1,66	7 000	–	0,65	E2.3210 A-2Z	–
	90	30,2	51	39	1,66	7 000	4 800	0,65	* 3210 A-2Z	* 3210 A-2RS1
	110	44,4	90	64	2,75	6 000	–	1,7	E2.3310 A-2Z	–
	110	44,4	90	64	2,75	6 000	4 300	1,7	* 3310 A-2Z	* 3310 A-2RS1
55	100	33,3	60	47,5	2	6 300	–	0,91	E2.3211 A-2Z	–
	100	33,3	60	47,5	2	6 300	4 500	0,91	* 3211 A-2Z	* 3211 A-2RS1
	120	49,2	112	81,5	3,45	5 300	–	2,65	E2.3311 A-2Z	–
	120	49,2	112	81,5	3,45	5 300	3 800	2,65	* 3311 A-2Z	* 3311 A-2RS1
60	110	36,5	73,5	58,5	2,5	5 600	–	1,2	E2.3212 A-2Z	–
	110	36,5	73,5	58,5	2,5	5 600	4 000	1,2	* 3212 A-2Z	* 3212 A-2RS1
	130	54	127	95	4,05	5 000	–	2,8	E2.3312 A-2Z	–
	130	54	127	95	4,05	5 000	–	2,8	* 3312 A-2Z	–
65	120	38,1	80,6	73,5	3,1	4 800	3 600	1,75	3213 A-2Z	3213 A-2RS1
	140	58,7	146	110	4,55	4 500	–	4,1	* 3313 A-2Z	–
70	125	39,7	88,4	80	3,4	4 500	–	1,9	3214 A-2Z	–
	150	63,5	163	125	5	4 300	–	5,05	* 3314 A-2Z	–
75	130	41,3	95,6	88	3,75	4 500	–	2,1	3215 A-2Z	–
	160	68,3	176	140	5,5	4 000	–	5,6	* 3315 A-2Z	–

¹⁾ For available final variants → matrix 2, page 501

* SKF Explorer bearing

E2 → SKF Energy Efficient bearing

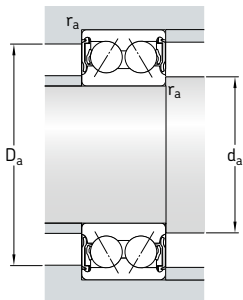

Dimensions

Abutment and fillet dimensions

d	d_1 ~	D_1 ~	$r_{1,2}$ min.	a	d_a min.	d_a max.	D_a max.	r_a max.
mm					mm			
45	52,8	77,1	1,1	49	52	52,5	78	1
	52,8	77,1	1,1	46	52	52,5	78	1
	55,6	90	1,5	58	54	91	91	1,5
	55,6	90	1,5	58	54	91	91	1,5
50	57,8	82,1	1,1	52	57	57,5	83	1
	57,8	82,1	1,1	52	57	57,5	83	1
	62	99,5	2	65	61	61,5	99,5	2
	62	99,5	2	65	61	61,5	99,5	2
55	63,2	92,3	1,5	57	63	63	91	1,5
	63,2	92,3	1,5	57	63	63	91	1,5
	68,4	109	2	72	66	68	109	2
	68,4	109	2	72	66	68	109	2
60	68,8	101	1,5	63	68,5	68,5	101	1,5
	68,8	101	1,5	63	68,5	68,5	101	1,5
	74,3	118	2,1	78	72	73	118	2
	74,3	118	2,1	78	72	73	118	2
65	85	103	1,5	71	74	76	111	1,5
	78,5	116	2,1	84	77	78,5	128	2
70	88,5	107	1,5	74	79	82	116	1,5
	84,2	125	2,1	89	82	84	138	2
75	91,9	112	1,5	77	84	84	121	1,5
	88,8	135	2,1	97	87	88,5	148	2

3.4 Four-point contact ball bearings d 15–55 mm

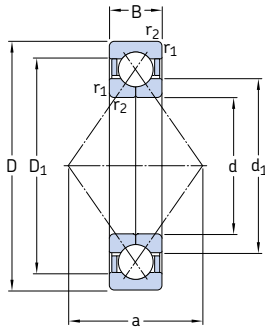

Basic design

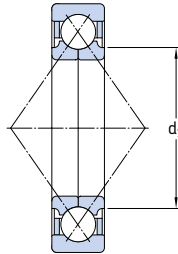

SKF Explorer bearing

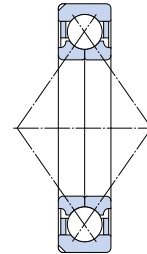

Bearing with locating slots

Principal dimensions			Basic load ratings		Fatigue load limit	Speed ratings		Mass	Designations ¹⁾	
d	D	B	dynamic	static		Reference speed	Limiting speed		Bearing with locating slots ²⁾	without locating slots
mm			kN		kN	r/min		kg	–	
15	35	11	12,7	8,3	0,355	22 000	36 000	0,062	QJ 202 N2MA	–
17	40	12	17	11,4	0,48	22 000	30 000	0,082	* QJ 203 N2MA	–
	47	14	23,4	15	0,64	17 000	28 000	0,14	QJ 303 N2MA	–
20	52	15	32	21,6	0,93	18 000	24 000	0,18	* QJ 304 N2MA	* QJ 304 MA
	52	15	32	21,6	0,93	20 000	24 000	0,18	* QJ 304 N2PHAS	–
25	52	15	27	21,2	0,9	16 000	22 000	0,16	* QJ 205 N2MA	–
	62	17	42,5	30	1,27	15 000	20 000	0,29	* QJ 305 N2MA	* QJ 305 MA
30	62	16	37,5	30,5	1,29	14 000	19 000	0,24	* QJ 206 N2MA	* QJ 206 MA
	72	19	53	41,5	1,76	12 000	17 000	0,42	* QJ 306 N2MA	* QJ 306 MA
	72	19	53	41,5	1,76	14 000	17 000	0,42	* QJ 306 N2PHAS	–
35	72	17	49	41,5	1,76	12 000	17 000	0,35	* QJ 207 N2MA	–
	80	21	64	51	2,16	11 000	15 000	0,57	* QJ 307 N2MA	* QJ 307 MA
	80	21	64	51	2,16	13 000	15 000	0,57	* QJ 307 N2PHAS	–
40	80	18	56	49	2,08	11 000	15 000	0,45	–	* QJ 208 MA
	90	23	78	64	2,7	10 000	14 000	0,78	* QJ 308 N2MA	* QJ 308 MA
	90	23	78	64	2,7	11 000	14 000	0,78	* QJ 308 N2PHAS	–
45	85	19	63	56	2,36	10 000	14 000	0,52	–	* QJ 209 MA
	100	25	100	83	3,55	9 000	12 000	1,05	* QJ 309 N2MA	* QJ 309 MA
	100	25	100	83	3,55	10 000	12 000	1,05	* QJ 309 N2PHAS	QJ 309 PHAS
50	90	20	65,5	61	2,6	9 000	13 000	0,59	–	* QJ 210 MA
	110	27	118	100	4,25	8 000	11 000	1,35	–	* QJ 310 MA
	110	27	118	100	4,25	9 000	11 000	1,35	–	* QJ 310 PHAS
55	100	21	85	83	3,55	8 000	11 000	0,77	* QJ 211 N2MA	* QJ 211 MA
	120	29	137	118	5	7 000	10 000	1,75	* QJ 311 N2MA	* QJ 311 MA

¹⁾ For available final variants → matrix 3, page 502

²⁾ For dimensions of locating slots → table 3, page 484

* SKF Explorer bearing

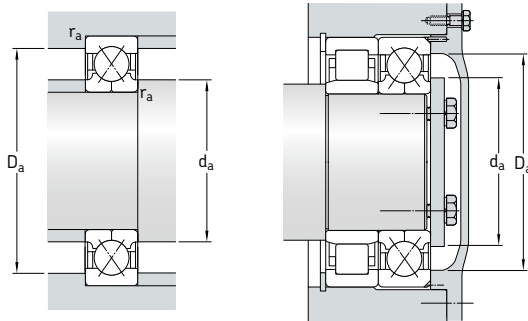

Dimensions

Abutment and fillet dimensions

d	d ₁ ~	D ₁ ~	r _{1,2} min.	a	d _a min.	D _a max.	r _a max.
mm					mm		
15	22	28,1	0,6	18	19,2	30,8	0,6
17	23,5 27,7	32,5 36,3	0,6 1	20 22	21,2 22,6	35,8 41,4	0,6 1
20	27,5 27,5	40,8 40,8	1,1 1,1	25 25	27 27	45 45	1 1
25	31,5 34	43 49	1 1,1	27 30	30,6 32	46,4 55	1 1
30	37,5 40,5 40,5	50,8 58,2 58,2	1 1,1 1,1	32 36 36	35,6 37 37	56,4 65 65	1 1 1
35	44 46,2 46,2	59 64,3 64,3	1,1 1,5 1,5	37 40 40	42 44 44	65 71 71	1 1,5 1,5
40	49,5 52 52	66 72,5 72,5	1,1 1,5 1,5	42 46 46	47 49 49	73 81 81	1 1,5 1,5
45	54,5 58 58	72 81,2 81,2	1,1 1,5 1,5	46 51 51	52 54 54	78 91 91	1 1,5 1,5
50	59,5 65 65	76,5 90 90	1,1 2 2	49 56 56	57 61 61	83 99 99	1 2 2
55	66 70,5	84,7 97,8	1,5 2	54 61	64 66	91 109	1,5 2

3.4 Four-point contact ball bearings d 60–95 mm

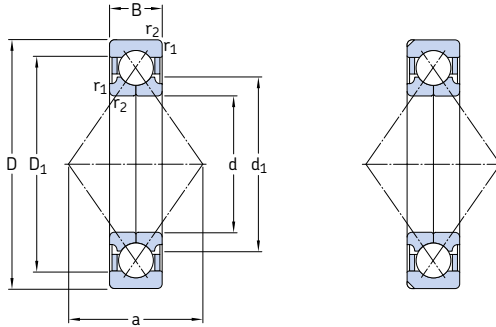

Bearing with locating slots

Principal dimensions			Basic load ratings		Fatigue load limit	Speed ratings		Mass	Designations ¹⁾	
d	D	B	C	C ₀	P _u	Reference speed	Limiting speed	kg	Bearing with locating slots ²⁾	without locating slots
mm			kN		kN	r/min		kg	–	
60	110	22	96,5	93	4	7 500	10 000	0,99	* QJ 212 N2MA	* QJ 212 MA
	110	22	96,5	93	4	8 500	10 000	0,99	* QJ 212 N2PHAS	–
	130	31	156	137	5,85	6 700	9 000	2,15	* QJ 312 N2MA	* QJ 312 MA
	130	31	156	137	5,85	7 500	9 000	2,15	–	* QJ 312 PHAS
65	120	23	110	112	4,75	6 700	9 500	1,2	* QJ 213 N2MA	* QJ 213 MA
	120	23	110	112	4,75	8 000	9 500	1,2	* QJ 213 N2PHAS	–
	140	33	176	156	6,55	6 300	8 500	2,7	–	* QJ 313 MA
	140	33	176	156	6,55	7 000	8 500	2,7	* QJ 313 N2PHAS	–
70	125	24	120	122	5,2	6 300	9 000	1,3	* QJ 214 N2MA	* QJ 214 MA
	125	24	120	122	5,2	7 500	9 000	1,3	* QJ 214 N2PHAS	–
	150	35	200	180	7,35	5 600	8 000	3,15	* QJ 314 N2MA	* QJ 314 MA
	150	35	200	180	7,35	6 700	8 000	3,15	* QJ 314 N2PHAS	–
75	130	25	125	132	5,6	6 300	8 500	1,45	* QJ 215 N2MA	* QJ 215 MA
	130	25	125	132	5,6	7 000	8 500	1,45	* QJ 215 N2PHAS	–
	160	37	216	200	7,8	5 300	7 500	3,9	* QJ 315 N2MA	–
	160	37	216	200	7,8	6 300	7 500	3,9	* QJ 315 N2PHAS	–
80	140	26	146	156	6,4	5 600	8 000	1,85	* QJ 216 N2MA	* QJ 216 MA
	170	39	232	228	8,65	5 000	7 000	4,6	* QJ 316 N2MA	–
	170	39	232	228	8,65	5 600	7 000	4,6	* QJ 316 N2PHAS	–
85	150	28	156	173	6,7	5 300	7 500	2,25	* QJ 217 N2MA	* QJ 217 MA
	180	41	250	255	8,65	4 800	6 700	5,45	* QJ 317 N2MA	–
90	160	30	186	200	7,65	5 000	7 000	2,75	* QJ 218 N2MA	–
	190	43	285	305	11	4 500	6 300	6,45	* QJ 318 N2MA	–
	190	43	285	305	11	5 000	6 300	6,45	* QJ 318 N2PHAS	–
95	170	32	212	232	8,5	4 800	6 700	3,35	* QJ 219 N2MA	–
	200	45	305	340	11,8	4 300	6 000	7,45	* QJ 319 N2MA	–
	200	45	305	340	11,8	4 800	6 000	7,45	* QJ 319 N2PHAS	–

¹⁾ For available final variants → matrix 3, page 502

²⁾ For dimensions of locating slots → table 3, page 484

* SKF Explorer bearing

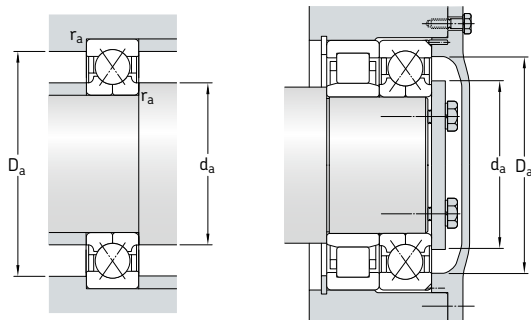

Dimensions

Abutment and fillet dimensions

d	d ₁ ~	D ₁ ~	r _{1,2} min.	a	d _a min.	D _a max.	r _a max.
mm					mm		
60	72	93	1,5	60	69	101	1,5
	72	93	1,5	60	69	101	1,5
	77	106	2,1	67	72	118	2
	77	106	2,1	67	72	118	2
65	78,5	101	1,5	65	74	111	1,5
	78,5	101	1,5	65	74	111	1,5
	82,5	115	2,1	72	77	128	2
	82,5	115	2,1	72	77	128	2
70	83,5	106	1,5	68	79	116	1,5
	83,5	106	1,5	68	79	116	1,5
	89	123	2,1	77	82	138	2
	89	123	2,1	77	82	138	2
75	88,5	112	1,5	72	84	121	1,5
	88,5	112	1,5	72	84	121	1,5
	104	131	2,1	82	87	148	2
	104	131	2,1	82	87	148	2
80	95,3	120	2	77	91	130	2
	111	139	2,1	88	92	158	2
	111	139	2,1	88	92	158	2
85	100	128	2	83	96	139	2
	117	148	3	93	99	166	2,5
90	114	136	2	88	101	149	2
	124	156	3	98	104	176	2,5
	124	156	3	98	104	176	2,5
95	120	145	2,1	93	107	158	2
	131	165	3	103	109	186	2,5
	131	165	3	103	109	186	2,5

3.4 Four-point contact ball bearings d 100–200 mm

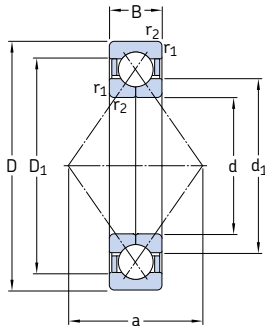

Basic design

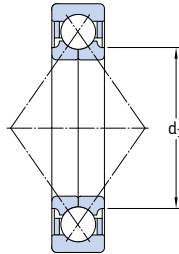

SKF Explorer bearing

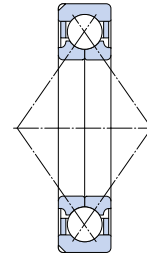

Bearing with locating slots

Principal dimensions			Basic load ratings		Fatigue load limit	Speed ratings		Mass	Designation ¹⁾ Bearing with locating slots ²⁾
d	D	B	C	C ₀		Reference speed	Limiting speed		
mm			kN		kN	r/min		kg	–
100	180	34	236	265	9,5	4 500	6 300	4,05	* QJ 220 N2MA
	215	47	345	400	13,7	4 000	5 600	9,3	* QJ 320 N2MA
110	200	38	280	325	11,2	4 000	5 600	5,6	* QJ 222 N2MA
	240	50	390	480	15,3	3 600	4 800	12,5	* QJ 322 N2MA
120	215	40	300	365	12	3 600	5 000	6,95	* QJ 224 N2MA
	260	55	415	530	16,3	3 200	4 500	16	* QJ 324 N2MA
130	230	40	310	400	12,7	3 400	4 800	7,75	* QJ 226 N2MA
	280	58	455	610	18	3 000	4 000	19,5	* QJ 326 N2MA
140	250	42	345	475	14,3	3 200	4 300	9,85	* QJ 228 N2MA
	300	62	500	695	20	2 800	3 800	24	* QJ 328 N2MA
150	270	45	400	570	16,6	3 000	4 000	12,5	* QJ 230 N2MA
	320	65	530	765	21,2	2 600	3 600	29	* QJ 330 N2MA
160	290	48	450	670	19	2 800	3 800	15,5	* QJ 232 N2MA
	340	68	570	880	23,6	2 400	3 400	34,5	* QJ 332 N2MA
170	310	52	455	720	20	2 600	3 400	19,5	* QJ 234 N2MA
	360	72	655	1 040	27	2 200	3 200	41,5	* QJ 334 N2MA
180	320	52	475	765	20,8	2 400	3 400	20,5	* QJ 236 N2MA
	380	75	680	1 100	28	2 200	3 000	47,5	* QJ 336 N2MA
190	340	55	510	850	22,4	2 200	3 200	23,5	* QJ 238 N2MA
	400	78	702	1 160	28,5	1 700	2 800	49	QJ 338 N2MA
200	360	58	540	915	23,2	1 800	3 000	28,5	QJ 240 N2MA

¹⁾ For available final variants → matrix 3, page 502

²⁾ For dimensions of locating slots → table 3, page 484

* SKF Explorer bearing

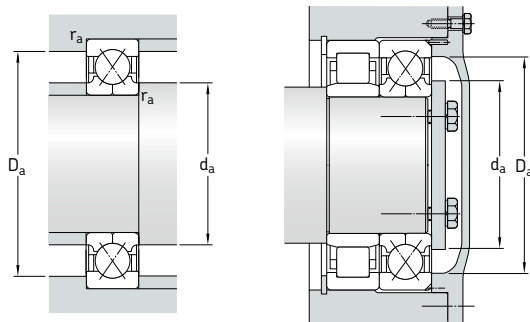

Dimensions

Abutment and fillet dimensions

d	d ₁ ~	D ₁ ~	r _{1,2} min.	a	d _a min.	D _a max.	r _a max.
mm							
100	127	153	2,1	98	112	168	2
	139	176	3	110	114	201	2
110	141	169	2,1	109	122	188	2
	154	196	3	123	124	226	2,5
120	152	183	2,1	117	132	203	2
	169	211	3	133	134	246	2,5
130	165	195	3	126	144	216	2,5
	182	227	4	144	147	263	3
140	179	211	3	137	154	236	2,5
	196	244	4	154	158	282	3
150	194	226	3	147	164	256	2,5
	211	259	4	165	167	303	3
160	204	243	3	158	174	276	2,5
	224	276	4	175	177	323	3
170	204	243	4	168	187	293	3
	237	293	4	186	187	343	3
180	231	269	4	175	197	303	3
	252	309	4	196	197	363	3
190	244	285	4	185	207	323	3
	263	326	5	207	210	380	4
200	258	302	4	196	217	363	3



SKF

4 Self-aligning ball bearings



Designs and variants	538	Product tables	
Basic design bearings.	539	4.1 Self-aligning ball bearings	552
Bearings with an extended inner ring . .	540	4.2 Sealed self-aligning ball bearings . .	560
Cages.	540	4.3 Self-aligning ball bearings with an extended inner ring	562
Sealing solutions	540	4.4 Self-aligning ball bearings on an adapter sleeve.	564
Greases for sealed bearings.	540		
Bearing data	542	Other self-aligning ball bearings	
(Dimension standards, tolerances, internal clearance, misalignment, friction, starting torque, power loss, defect frequencies)		Bearings with Solid Oil	1185
Loads	544		
(Minimum load, axial load carrying capacity, equivalent loads)			
Temperature limits.	545		
Permissible speed.	545		
Design of bearing arrangements	546		
Bearings on sleeves	546		
Bearing / adapter sleeve kits	547		
Appropriate bearing housings	547		
Mounting bearings with a tapered bore	548		
Designation system	550		

4 Self-aligning ball bearings

Designs and variants

Self-aligning ball bearings have two rows of balls and a common sphered raceway in the outer ring. The bearings are insensitive to angular misalignment of the shaft relative to the housing. Self-aligning ball bearings generate less friction than any other type of rolling bearing, which enables them to run cooler even at high speeds.

SKF self-aligning ball bearings are available in several designs, including:

- basic design bearings (→ **fig. 1**)
- bearings with an extended inner ring (→ **fig. 2**)
- sealed bearings (→ **fig. 3**)

More information

Bearing life and load ratings 63

Design considerations 159

Bearing systems 160

Recommended fits 169

Abutment and fillet dimensions 208

Lubrication 239

Mounting, dismounting and bearing care 271

Mounting instructions for individual bearings → skf.com/mount

SKF bearing maintenance handbook

. (ISBN 978-91-978966-4-1)

SKF Drive-up Method → skf.com/drive-up

Fig. 1

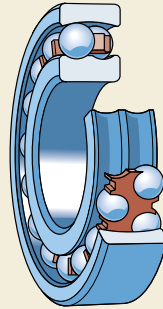

Fig. 2

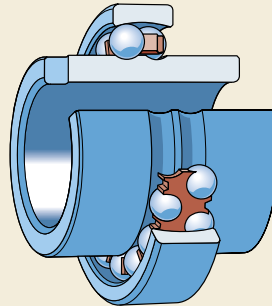
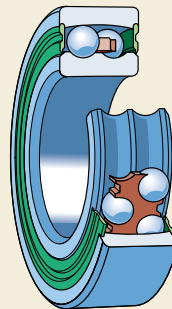

Fig. 3



Basic design bearings

Basic design self-aligning ball bearings are available with a cylindrical bore and, for certain sizes, with a 1:12 tapered bore (designation suffix K).

Large self-aligning ball bearings in the 130 and 139 series, originally developed for specific applications in the paper industry, can be used in any application where low friction is preferred over high load carrying capacity. These bearings are equipped with an annular groove and three equally spaced lubrication holes in the outer ring and six equally spaced lubrication holes in the inner ring (→ **fig. 4**).

The balls of some bearings in the 12 and 13 series protrude from the side faces of the bearing. The values of the protrusion are listed in **table 1** and should be considered when designing components in close proximity to the bearing.

Fig. 4

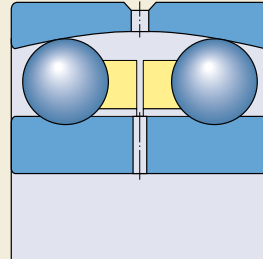

4

Table 1

Protrusion of balls from the bearing side faces

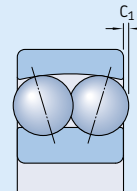

Bearing	Protrusion C_1
mm	
1224 (K)	1,3
1226	1,4
1318 (K)	1,1
1319 (K)	1,5
1320 (K)	2,5
1322 (K)	2,6

4 Self-aligning ball bearings

Bearings with an extended inner ring

Self-aligning ball bearings with an extended inner ring are designed for less demanding applications that use commercial grade shafting. The special bore tolerance, class JS7 (→ **table 4, page 543**), facilitates mounting and dismounting.

Self-aligning ball bearings with an extended inner ring are located axially on the shaft by means of a slot at one end of the inner ring that engages a pin or shoulder screw (→ **fig. 5**) fitted to the shaft. The holding device also prevents the shaft from spinning in the bearing bore.

When two of these bearings are used to support a shaft, they should be positioned so that the inner ring slots either face each other, or are opposed to each other (→ **fig. 5**). If this is not the case, the shaft is located axially in one direction only.

Cages

Depending on their series and size, SKF self-aligning ball bearings are fitted with one of the cages shown in **table 2**.

The lubricants generally used for rolling bearings do not have a detrimental effect on cage properties. However, some synthetic oils and greases with a synthetic oil base and lubricants containing a high proportion of EP additives, when used at high temperatures, can have a detrimental effect on polyamide cages. For additional information about the

suitability of cages, refer to *Cages* (→ **page 37**) and *Cage materials* (→ **page 152**).

Sealing solutions

Some self-aligning ball bearings in the 22 and 23 series are also available with seals (→ **fig. 6**).

Sealed bearings have a contact seal on both sides that is made of oil and wear-resistant NBR and reinforced with a sheet steel insert (designation suffix 2RS1).

Sealed bearings are lubricated for the life of the bearing and should not be washed or relubricated. The bearings are considered maintenance-free. If they are to be hot mounted, SKF does not recommend heating the bearings above 80 °C (175 °F).

Greases for sealed bearings

Depending on their outside diameter, sealed bearings are filled with one of the two greases listed in **table 3**. Both have good corrosion inhibiting properties.

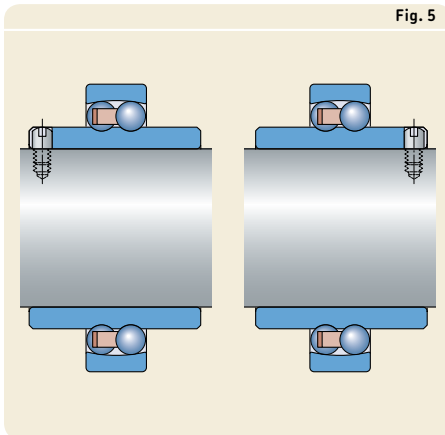

Fig. 5

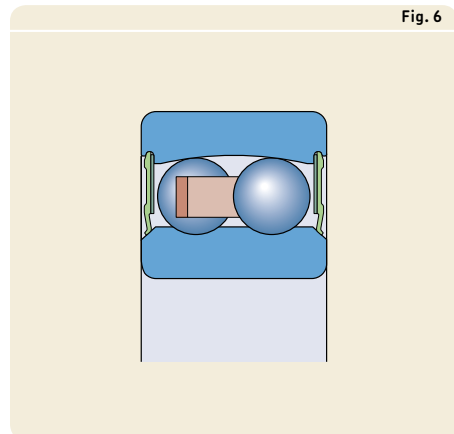
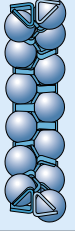
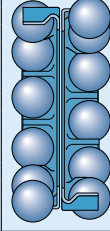
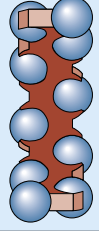
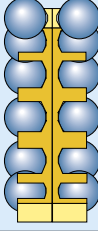

Fig. 6

Table 2

Cages for self-aligning ball bearings

				
Cage type	One-piece, ball centred	Two-piece, ball centred	One-piece snap-type, ball centred	One- or two-piece, ball centred
Material	Stamped steel		PA66, glass fibre reinforced	Machined brass
Suffix	-	-	TN9	M - when $d \geq 150$ mm

For bearings with non-standard cages, contact SKF.

Table 3

Technical specifications of SKF standard greases for sealed self-aligning ball bearings

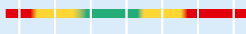
Bearing outside diameter [mm]	Grease	Temperature range ¹⁾						Thickener	Base oil type	NLGI consistency class	Base oil viscosity [mm ² /s]	
		-50	0	50	100	150	200				250	at 40°C (105 °F)
D ≤ 62	MT47							Lithium soap	Mineral	2	70	7,3
D > 62	MT33							Lithium soap	Mineral	3	100	10

-60 30 120 210 300 390 480 °F

¹⁾ Refer to the SKF traffic light concept → page 244

Bearing data

Dimension standards	Boundary dimensions: ISO 15 Bearings with an extended inner ring: DIN 630, part 2, withdrawn in 1993
Tolerances For additional information (→ page 132)	Normal Bearings with an extended inner ring: bore to tolerance class JS7 (→ table 4) in accordance with ISO 286-2 Values: ISO 492, (→ table 3, page 137)
Internal clearance For additional information (→ page 149)	Normal, C3 Check availability of C2 (cylindrical bore) Bearings in the 130 and 139 series: C3 Bearings with an extended inner ring: ranging from the minimum value of C2 to the maximum value of Normal Values: ISO 5753-1 (→ table 5) Values are valid for unmounted bearings under zero measuring load.
Misalignment	Guideline values for normal operating condition: (→ table 6). Whether these values can be fully exploited depends on the design of the bearing arrangement and the type of external seal.
Friction, starting torque, power loss	Frictional moment, starting torque and power loss can be calculated as specified under <i>Friction</i> (→ page 97), or using the tools available online at skf.com/bearingcalculator .
Defect frequencies	Defect frequencies can be calculated using the tools available online at skf.com/bearingcalculator .

Table 4

Bore tolerance of self-aligning ball bearings with an extended inner ring

Bore diameter d		Tolerance class JS7 Deviation	
over	incl.	high	low
mm		µm	
18	30	+10,5	-10,5
30	50	+12,5	-12,5
50	80	+15	-15

Table 5

Radial internal clearance of self-aligning ball bearings

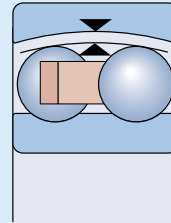

Bore diameter d		Radial internal clearance			
over	incl.	C2		C3	
mm		min.	max.	min.	max.

Bearings with a cylindrical bore

2,5	6	1	8	5	15	10	20
6	10	2	9	6	17	12	25
10	14	2	10	6	19	13	26
14	18	3	12	8	21	15	28
18	24	4	14	10	23	17	30
24	30	5	16	11	24	19	35
30	40	6	18	13	29	23	40
40	50	6	19	14	31	25	44
50	65	7	21	16	36	30	50
65	80	8	24	18	40	35	60
80	100	9	27	22	48	42	70
100	120	10	31	25	56	50	83
120	140	10	38	30	68	60	100
140	160	-	-	-	-	70	120
160	180	-	-	-	-	82	138
180	200	-	-	-	-	93	157
200	225	-	-	-	-	100	170
225	250	-	-	-	-	115	195

Bearings with a tapered bore

18	24	-	-	13	26	20	33
24	30	-	-	15	28	23	39
30	40	-	-	19	35	29	46
40	50	-	-	22	39	33	52
50	65	-	-	27	47	41	61
65	80	-	-	35	57	50	75
80	100	-	-	42	68	62	90
100	120	-	-	50	81	75	108

Table 6

Permissible angular misalignment

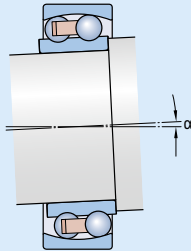

Bearings/series	Misalignment α
-	°
108, 126, 127, 129, 135	3
12 (E)	2,5
13 (E)	3
22 (E)	2,5
22 E-2RS1	1,5
23 (E)	3
23 E-2RS1	1,5
112 (E)	2,5
130, 139	3

Loads

	Self-aligning ball bearings	Symbols
<p>Minimum load</p> <p>For additional information (→ page 86)</p>	$F_{rm} = k_r \left(\frac{v n}{1\,000} \right)^{2/3} \left(\frac{d_m}{100} \right)^2$ <p>The weight of the components supported by the bearing, together with external forces, generally exceed the requisite minimum load. If this is not the case, the bearing must be subjected to an additional radial load.</p>	<p>B = bearing width [mm] d = bearing bore diameter [mm] d_m = bearing mean diameter [mm] = 0,5 (d + D) e = calculation factor (→ product tables) F_a = axial load [kN] F_{ap} = maximum permissible axial load [kN] F_r = radial load [kN] F_{rm} = minimum radial load [kN] k_r = minimum load factor (→ product tables) n = rotational speed [r/min] P = equivalent dynamic bearing load [kN] P₀ = equivalent static bearing load [kN] Y₀, Y₁, Y₂ = calculation factors (→ product tables) v = actual operating viscosity of the lubricant [mm²/s]</p>
<p>Axial load carrying capacity</p> <p>For additional information (→ page 85)</p>	<p>Bearings mounted on an adapter sleeve on smooth shafts without a fixed abutment:</p> $F_{ap} = 0,003 B d$ <p>provided the bearings are correctly mounted.</p>	
<p>Equivalent dynamic bearing load</p> <p>For additional information (→ page 85)</p>	$F_a/F_r \leq e \rightarrow P = F_r + Y_1 F_a$ $F_a/F_r > e \rightarrow P = 0,65 F_r + Y_2 F_a$	
<p>Equivalent static bearing load</p> <p>For additional information (→ page 88)</p>	$P_0 = F_r + Y_0 F_a$	

Temperature limits

The permissible operating temperature for self-aligning ball bearings can be limited by:

- the dimensional stability of the bearing rings and balls
- the cage
- the seals
- the lubricant

When temperatures outside the permissible range are expected, contact the SKF application engineering service.

Bearing rings and balls

SKF self-aligning ball bearings undergo a special heat treatment. The bearings are heat stabilized up to at least 120 °C (250 °F).

Cages

Steel or brass cages can be used at the same operating temperatures as the bearing rings and balls. For temperature limits of polymer cages, refer to *Cage materials* (→ **page 152**).

Seals

The permissible operating temperature for NBR seals is -40 to +100 °C (-40 to +210 °F). Temperatures up to 120 °C (250 °F) can be tolerated for brief periods.

Lubricants

Temperature limits for the greases used in sealed SKF self-aligning ball bearings are provided in **table 3** (→ **page 541**). Temperature limits for other SKF greases are provided under *Lubrication* (→ **page 239**).

When using lubricants not supplied by SKF, the temperature limits should be evaluated according to the SKF traffic light concept (→ **page 244**).

Permissible speed

The permissible speed can be estimated using the speed ratings listed in the product tables and applying the information provided under *Speeds* (→ **page 117**). If no reference speed is listed in the product tables, the limiting speed is the permissible speed.

4 Self-aligning ball bearings

Design of bearing arrangements

Bearings on sleeves

Self-aligning ball bearings with a tapered bore can be mounted on plain or stepped shafts with an adapter sleeve (→ **fig. 7**) or on stepped shafts with a withdrawal sleeve (→ **fig. 8**). Adapter sleeves are supplied complete with a locking device. For additional information about sleeves, refer to *Bearing accessories* (→ **page 1269**).

Adapter sleeves are more popular than withdrawal sleeves as they do not require axial locating devices on the shaft. Therefore, only

adapter sleeves are listed together with the suitable bearings in this catalogue.

When using sealed self-aligning ball bearings on an adapter sleeve, the locking device must not interfere with the seal. To avoid this, use an appropriate SKF adapter sleeve assembly, as listed in the product tables (→ **page 564**). Sealed bearings use either a standard sleeve or an E design sleeve (→ **fig. 9**). Alternatively, a spacer ring can be inserted between the bearing and the lock washer.

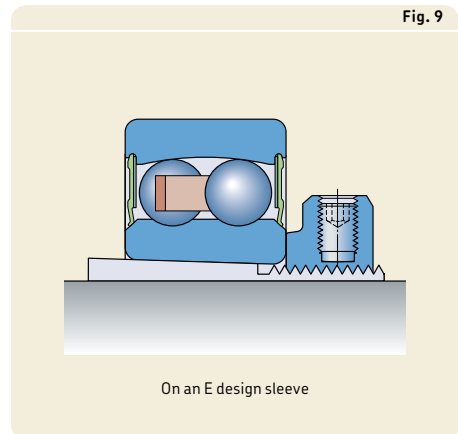
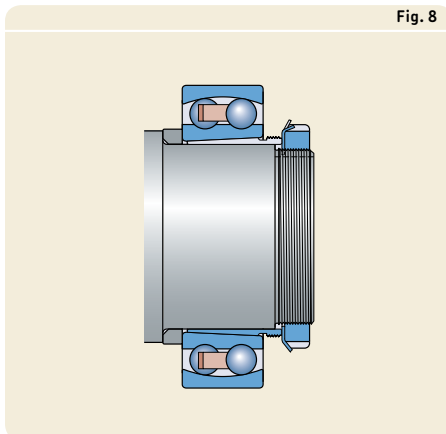
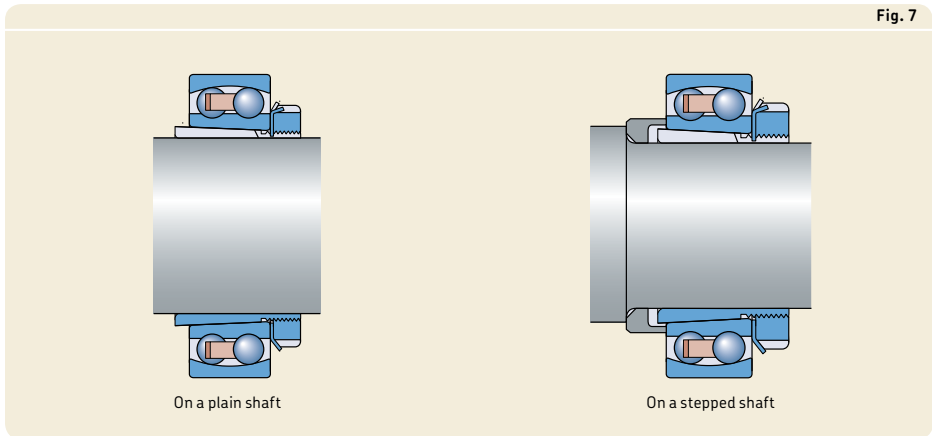

Bearing / adapter sleeve kits

To facilitate procurement and to provide the correct bearing / sleeve combination, SKF offers kits for the most popular sizes, containing the self-aligning ball bearing together with the suitable adapter sleeve assembly.

These kits are listed in **table 7**. The technical data for bearings and sleeves are listed in the relevant product tables.

Appropriate bearing housings

The combination of an SKF self-aligning ball bearing, adapter sleeve, where needed, and an appropriate SKF bearing housing provides a cost-effective, interchangeable and reliable solution that fulfils the demand for easy maintenance. Appropriate SKF housings are available in a variety of designs and sizes for a wide range of applications. The designs include:

- SNL, SE plummer (pillow) block housings in the 2, 3, 5 and 6 series
- FNL flanged housings
- SAF plummer (pillow) block housings for inch shafts

Additional information about SKF bearing housings is available online at skf.com/housings.

Table 7

SKF self-aligning ball bearing / adapter sleeve kits			
Bearing kit Designation	Parts Designation Bearing	Sleeve	Shaft diameter
			mm
KAM 1206	1206 EKTN9/C3	H 206	25
KAM 1207	1207 EKTN9/C3	H 207	30
KAM 1208	1208 EKTN9/C3	H 208	35
KAM 1209	1209 EKTN9/C3	H 209	40
KAM 1210	1210 EKTN9/C3	H 210	45
KAM 1211	1211 EKTN9/C3	H 211	50

4 Self-aligning ball bearings

Mounting bearings with a tapered bore

Bearings with a tapered bore are always mounted with an interference fit. To obtain the proper degree of interference, one of the following methods can be used:

- 1 feeling the clearance reduction by swivelling the outer ring
- 2 measuring the lock nut tightening angle
- 3 measuring the axial drive-up
- 4 applying the SKF Drive-up Method

For additional information about these mounting methods, refer to *Mounting, dismounting and bearing care* (→ **page 271**), or the *SKF bearing maintenance handbook*.

The most suitable method for bearings mounted on shafts with a diameter ≥ 50 mm is the SKF Drive-up Method, which is a fast, reliable and safe method to achieve the appropriate interference fit. Additional information is available online at skf.com/drive-up.

Recommended values to apply methods 2 and 3 are listed in **table 8**.

Feeling the clearance reduction by swivelling the outer ring

When mounting self-aligning ball bearings with Normal radial clearance, it is generally sufficient to check clearance reduction during axial drive-up by turning and swivelling the outer ring (→ **fig. 10**). The clearance reduction in the bearing is sufficient when the outer ring can be turned easily, but a slight resistance is felt when it is swivelled out.

Fig. 10

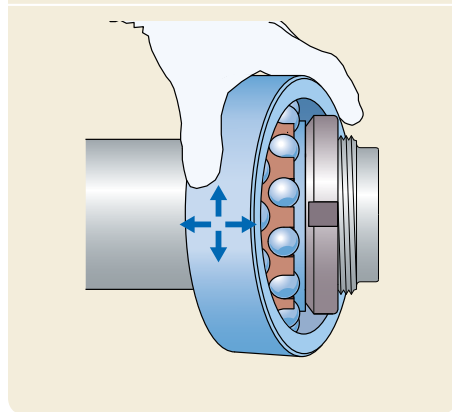
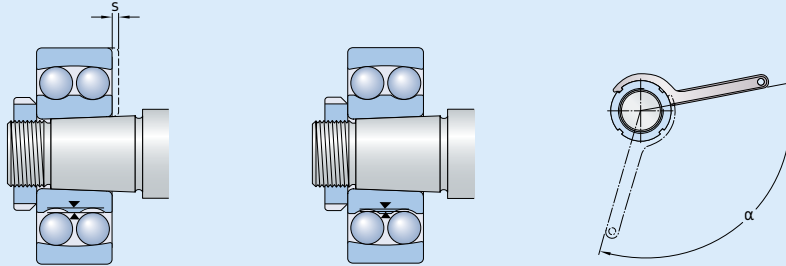

Table 8

Drive-up data for self-aligning ball bearings with a tapered bore



Bore diameter d	Axial drive-up s ¹⁾	Lock nut tightening angle α
mm	mm	°
20	0,22	80
25	0,22	55
30	0,22	55
35	0,30	70
40	0,30	70
45	0,35	80
50	0,35	80
55	0,40	75
60	0,40	75
65	0,40	80
70	0,40	80
75	0,45	85
80	0,45	85
85	0,60	110
90	0,60	110
95	0,60	110
100	0,60	110
110	0,70	125
120	0,70	125

Valid only for solid steel shafts and general applications. The listed values are to be used as guideline values only, as it is difficult to establish an exact starting position. Also, the axial drive-up s differs slightly between the different bearings series.

¹⁾ Not valid for the SKF Drive-up Method.

4 Self-aligning ball bearings

Designation system

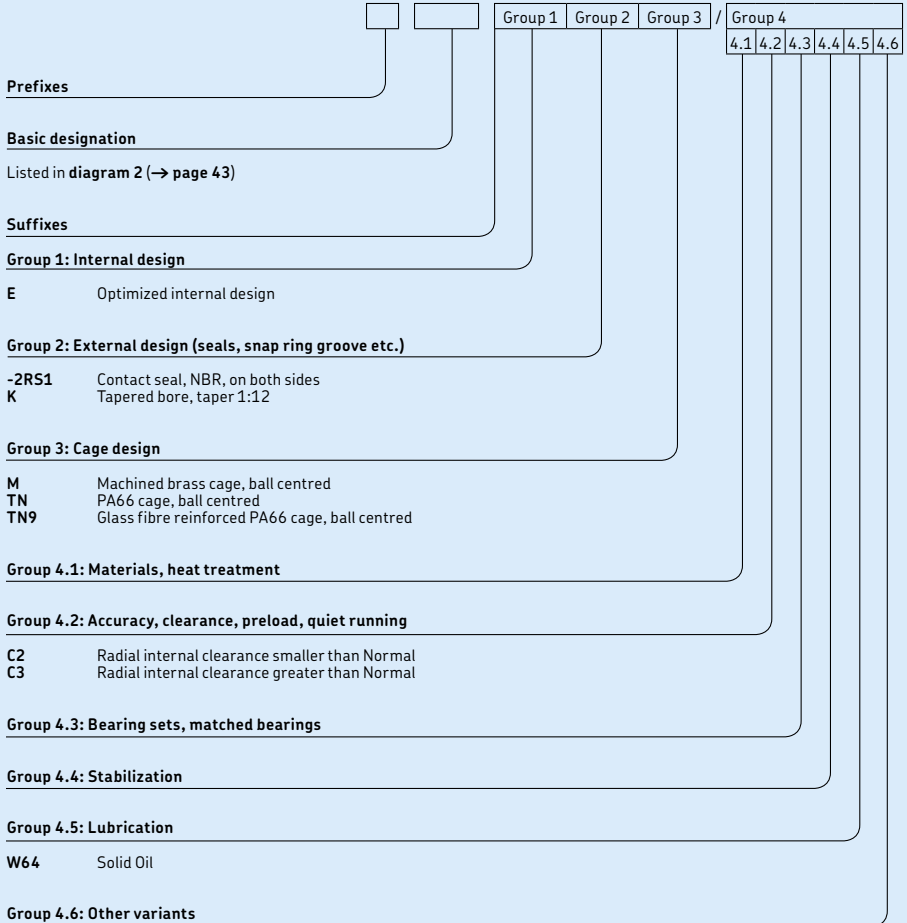

4.1 Self-aligning ball bearings d 5 – 30 mm

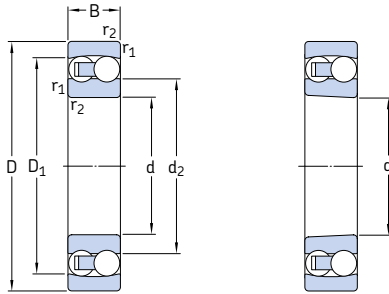

Cylindrical bore

Tapered bore

Principal dimensions			Basic load ratings		Fatigue load limit	Speed ratings		Mass	Designations	
d	D	B	dynamic	static		Reference speed	Limiting speed		Bearing with cylindrical bore	tapered bore
mm			C	C ₀	P _u	r/min		kg	-	
5	19	6	2,51	0,48	0,025	63 000	45 000	0,009	135 TN9	-
6	19	6	2,51	0,48	0,025	70 000	45 000	0,009	126 TN9	-
7	22	7	2,65	0,56	0,029	63 000	40 000	0,014	127 TN9	-
8	22	7	2,65	0,56	0,029	60 000	40 000	0,014	108 TN9	-
9	26	8	3,9	0,82	0,043	60 000	38 000	0,022	129 TN9	-
10	30	9	5,53	1,18	0,061	56 000	36 000	0,034	1200 ETN9	-
	30	14	8,06	1,73	0,09	50 000	34 000	0,047	2200 ETN9	-
12	32	10	6,24	1,43	0,072	50 000	32 000	0,04	1201 ETN9	-
	32	14	8,52	1,9	0,098	45 000	30 000	0,053	2201 ETN9	-
	37	12	9,36	2,16	0,12	40 000	28 000	0,067	1301 ETN9	-
	37	17	11,7	2,7	0,14	38 000	28 000	0,095	2301	-
15	35	11	7,41	1,76	0,09	45 000	28 000	0,049	1202 ETN9	-
	35	14	8,71	2,04	0,11	38 000	26 000	0,06	2202 ETN9	-
	42	13	10,8	2,6	0,14	34 000	24 000	0,094	1302 ETN9	-
	42	17	11,9	2,9	0,15	32 000	24 000	0,12	2302	-
17	40	12	8,84	2,2	0,12	38 000	24 000	0,073	1203 ETN9	-
	40	16	10,6	2,55	0,14	34 000	24 000	0,088	2203 ETN9	-
	47	14	12,7	3,4	0,18	28 000	20 000	0,12	1303 ETN9	-
	47	19	14,3	3,55	0,19	30 000	22 000	0,16	2303	-
20	47	14	12,7	3,4	0,18	32 000	20 000	0,12	1204 ETN9	1204 EKTN9
	47	18	16,8	4,15	0,22	28 000	20 000	0,14	2204 ETN9	-
	52	15	14,3	4	0,21	26 000	18 000	0,16	1304 ETN9	-
	52	21	18,2	4,75	0,24	26 000	19 000	0,22	2304 TN9	-
25	52	15	14,3	4	0,21	28 000	18 000	0,14	1205 ETN9	1205 EKTN9
	52	18	16,8	4,4	0,23	26 000	18 000	0,16	2205 ETN9	2205 EKTN9
	62	17	19	5,4	0,28	22 000	15 000	0,26	1305 ETN9	1305 EKTN9
	62	24	27	7,1	0,37	22 000	16 000	0,34	2305 ETN9	2305 EKTN9
30	62	16	15,6	4,65	0,24	24 000	15 000	0,22	1206 ETN9	1206 EKTN9
	62	20	23,8	6,7	0,35	22 000	15 000	0,26	2206 ETN9	2206 EKTN9
	72	19	22,5	6,8	0,36	19 000	13 000	0,39	1306 ETN9	1306 EKTN9
	72	27	31,2	8,8	0,45	18 000	13 000	0,5	2306	2306 K

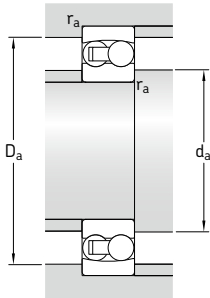

Dimensions				Abutment and fillet dimensions			Calculation factors				
d	d_2 ~	D_1 ~	$r_{1,2}$ min.	d_a min.	D_a max.	r_a max.	k_r	e	Y_1	Y_2	Y_0
mm				mm			-				
5	10,3	15,4	0,3	7,4	16,6	0,3	0,045	0,33	1,9	3	2
6	10,3	15,4	0,3	8,4	16,6	0,3	0,04	0,33	1,9	3	2
7	12,6	17,6	0,3	9,4	19,6	0,3	0,04	0,33	1,9	3	2
8	12,6	17,6	0,3	10,4	19,6	0,3	0,03	0,33	1,9	3	2
9	14,8	21,1	0,3	11,4	23,6	0,3	0,04	0,33	1,9	3	2
10	16,7	24,4	0,6	14,2	25,8	0,6	0,04	0,33	1,9	3	2
	15,3	24,3	0,6	14,2	25,8	0,6	0,045	0,54	1,15	1,8	1,3
12	18,2	26,4	0,6	16,2	27,8	0,6	0,04	0,33	1,9	3	2
	17,5	26,5	0,6	16,2	27,8	0,6	0,045	0,5	1,25	2	1,3
	20	30,8	1	17,6	31,4	1	0,04	0,35	1,8	2,8	1,8
	18,6	31	1	17,6	31,4	1	0,05	0,6	1,05	1,6	1,1
15	21,2	29,6	0,6	19,2	30,8	0,6	0,04	0,33	1,9	3	2
	20,9	30,2	0,6	19,2	30,8	0,6	0,045	0,43	1,5	2,3	1,6
	23,9	35,3	1	20,6	36,4	1	0,04	0,31	2	3,1	2,2
	23,2	35,2	1	20,6	36,4	1	0,05	0,52	1,2	1,9	1,3
17	24	33,6	0,6	21,2	35,8	0,6	0,04	0,31	2	3,1	2,2
	23,8	34,1	0,6	21,2	35,8	0,6	0,045	0,43	1,5	2,3	1,6
	28,9	41	1	22,6	41,4	1	0,04	0,3	2,1	3,3	2,2
	25,8	39,4	1	22,6	41,4	1	0,05	0,52	1,2	1,9	1,3
20	28,9	41	1	25,6	41,4	1	0,04	0,3	2,1	3,3	2,2
	27,4	41	1	25,6	41,4	1	0,045	0,4	1,6	2,4	1,6
	33,3	45,6	1,1	27	45	1	0,04	0,28	2,2	3,5	2,5
	28,8	43,7	1,1	27	45	1,1	0,05	0,52	1,2	1,9	1,3
25	33,3	45,6	1	30,6	46,4	1	0,04	0,28	2,2	3,5	2,5
	32,3	46,1	1	30,6	46,4	1	0,045	0,35	1,8	2,8	1,8
	37,8	52,5	1,1	32	55	1,1	0,04	0,28	2,2	3,5	2,5
	35,5	53,5	1,1	32	55	1,1	0,05	0,44	1,4	2,2	1,4
30	40,1	53	1	35,6	56,4	1	0,04	0,25	2,5	3,9	2,5
	38,8	55	1	35,6	56,4	1	0,045	0,33	1,9	3	2
	44,9	60,9	1,1	37	65	1,1	0,04	0,25	2,5	3,9	2,5
	41,7	60,9	1,1	37	65	1,1	0,05	0,44	1,4	2,2	1,4

4.1 Self-aligning ball bearings d 35 – 70 mm

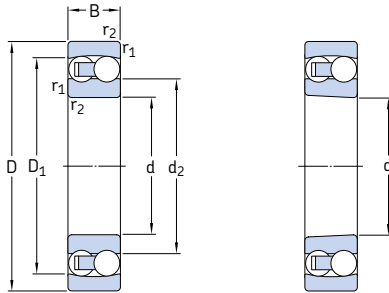

Cylindrical bore

Tapered bore

Principal dimensions			Basic load ratings dynamic static		Fatigue load limit	Speed ratings Reference Limiting speed speed		Mass	Designations Bearing with cylindrical bore	tapered bore
d	D	B	C	C ₀	P _u					
mm			kN		kN	r/min		kg	–	
35	72	17	19	6	0,31	20 000	13 000	0,32	1207 ETN9	1207 EKTN9
	72	23	30,2	8,8	0,455	18 000	12 000	0,4	2207 ETN9	2207 EKTN9
	80	21	26,5	8,5	0,43	16 000	11 000	0,51	1307 ETN9	1307 EKTN9
	80	31	39,7	11,2	0,59	16 000	12 000	0,68	2307 ETN9	2307 EKTN9
40	80	18	19,9	6,95	0,36	18 000	11 000	0,42	1208 ETN9	1208 EKTN9
	80	23	31,9	10	0,51	16 000	11 000	0,51	2208 ETN9	2208 EKTN9
	90	23	33,8	11,2	0,57	14 000	9 500	0,68	1308 ETN9	1308 EKTN9
	90	33	54	16	0,82	14 000	10 000	0,93	2308 ETN9	2308 EKTN9
45	85	19	22,9	7,8	0,4	17 000	11 000	0,47	1209 ETN9	1209 EKTN9
	85	23	32,5	10,6	0,54	15 000	10 000	0,55	2209 ETN9	2209 EKTN9
	100	25	39	13,4	0,7	12 000	8 500	0,96	1309 ETN9	1309 EKTN9
	100	36	63,7	19,3	1	13 000	9 000	1,25	2309 ETN9	2309 EKTN9
50	90	20	26,5	9,15	0,48	16 000	10 000	0,53	1210 ETN9	1210 EKTN9
	90	23	33,8	11,2	0,57	14 000	9 500	0,6	2210 ETN9	2210 EKTN9
	110	27	43,6	14	0,72	12 000	8 000	1,2	1310 ETN9	1310 EKTN9
	110	40	63,7	20	1,04	14 000	9 500	1,65	2310	2310 K
55	100	21	27,6	10,6	0,54	14 000	9 000	0,71	1211 ETN9	1211 EKTN9
	100	25	39	13,4	0,7	12 000	8 500	0,81	2211 ETN9	2211 EKTN9
	120	29	50,7	18	0,92	11 000	7 500	1,6	1311 ETN9	1311 EKTN9
	120	43	76,1	24	1,25	11 000	7 500	2,1	2311	2311 K
60	110	22	31,2	12,2	0,62	12 000	8 500	0,9	1212 ETN9	1212 EKTN9
	110	28	48,8	17	0,88	11 000	8 000	1,1	2212 ETN9	2212 EKTN9
	130	31	58,5	22	1,12	9 000	6 300	1,95	1312 ETN9	1312 EKTN9
	130	46	87,1	28,5	1,46	9 500	7 000	2,6	2312	2312 K
65	120	23	35,1	14	0,72	11 000	7 000	1,15	1213 ETN9	1213 EKTN9
	120	31	57,2	20	1,02	10 000	7 000	1,45	2213 ETN9	2213 EKTN9
	140	33	65	25,5	1,25	8 500	6 000	2,45	1313 ETN9	1313 EKTN9
	140	48	95,6	32,5	1,66	9 000	6 300	3,25	2313	2313 K
70	125	24	35,8	14,6	0,75	11 000	7 000	1,25	1214 ETN9	–
	125	31	44,2	17	0,88	10 000	6 700	1,5	2214	–
	150	35	74,1	27,5	1,34	8 500	6 000	3	1314	–
	150	51	111	37,5	1,86	8 000	6 000	3,9	2314	–

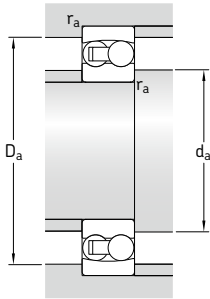

Dimensions				Abutment and fillet dimensions			Calculation factors				
d	d ₂	D ₁	r _{1,2} min.	d _a min.	D _a max.	r _a max.	k _r	e	Y ₁	Y ₂	Y ₀
mm	~	~		mm			-				
35	47	62,3	1,1	42	65	1,1	0,04	0,23	2,7	4,2	2,8
	45,3	64,2	1,1	42	65	1,1	0,045	0,31	2	3,1	2,2
	51,5	69,5	1,5	44	71	1,5	0,04	0,25	2,5	3,9	2,5
	46,5	68,4	1,5	44	71	1,5	0,05	0,46	1,35	2,1	1,4
40	53,6	68,8	1,1	47	73	1,1	0,04	0,22	2,9	4,5	2,8
	52,4	71,6	1,1	47	73	1,1	0,045	0,28	2,2	3,5	2,5
	61,5	81,5	1,5	49	81	1,1	0,04	0,23	2,7	4,2	2,8
	53,7	79,2	1,5	49	81	1,5	0,05	0,4	1,6	2,4	1,6
45	57,5	73,7	1,1	52	78	1,1	0,04	0,21	3	4,6	3,2
	55,3	74,6	1,1	52	78	1,1	0,045	0,26	2,4	3,7	2,5
	67,7	89,5	1,5	54	91	1,5	0,04	0,23	2,7	4,2	2,8
	60,1	87,4	1,5	54	91	1,5	0,05	0,33	1,9	3	2
50	61,7	79,5	1,1	57	83	1,1	0,04	0,21	3	4,6	3,2
	61,5	81,5	1,1	57	83	1,1	0,045	0,23	2,7	4,2	2,8
	70,3	95	2	61	99	2	0,04	0,24	2,6	4,1	2,8
	65,8	94,4	2	61	99	2	0,05	0,43	1,5	2,3	1,6
55	70,1	88,4	1,5	64	91	1,5	0,04	0,19	3,3	5,1	3,6
	67,7	89,5	1,5	64	91	1,5	0,045	0,23	2,7	4,2	2,8
	77,7	104	2	66	109	2	0,04	0,23	2,7	4,2	2,8
	72	103	2	66	109	2	0,05	0,4	1,6	2,4	1,6
60	78	97,6	1,5	69	101	1,5	0,04	0,19	3,3	5,1	3,6
	74,5	98,6	1,5	69	101	1,5	0,045	0,24	2,6	4,1	2,8
	91,6	118	2,1	72	118	2	0,04	0,22	2,9	4,5	2,8
	76,9	112	2,1	72	118	2	0,05	0,33	1,9	3	2
65	85,3	106	1,5	74	111	1,5	0,04	0,18	3,5	5,4	3,6
	80,7	107	1,5	74	111	1,5	0,045	0,24	2,6	4,1	2,8
	99	127	2,1	77	128	2	0,04	0,22	2,9	4,5	2,8
	85,5	122	2,1	77	128	2	0,05	0,37	1,7	2,6	1,8
70	87,4	109	1,5	79	116	1,5	0,04	0,18	3,5	5,4	3,6
	87,5	111	1,5	79	116	1,5	0,04	0,27	2,3	3,6	2,5
	97,7	129	2,1	82	138	2	0,045	0,22	2,9	4,5	2,8
	91,6	130	2,1	82	138	2	0,05	0,37	1,7	2,6	1,8

4.1 Self-aligning ball bearings d 75 – 130 mm

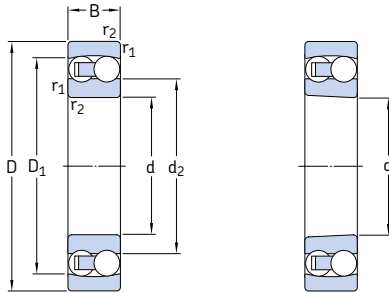

Cylindrical bore

Tapered bore

Principal dimensions			Basic load ratings		Fatigue load limit	Speed ratings		Mass	Designations	
d	D	B	dynamic	static		Reference speed	Limiting speed		Bearing with cylindrical bore	tapered bore
mm			C	C ₀	P _u	r/min		kg	–	
75	130	25	39	15,6	0,8	10 000	6 700	1,35	1215	1215 K
	130	31	58,5	22	1,12	9 000	6 300	1,6	2215 ETN9	2215 EKTN9
	160	37	79,3	30	1,43	8 000	5 600	3,55	1315	1315 K
	160	55	124	43	2,04	7 500	5 600	4,7	2315	2315 K
80	140	26	39,7	17	0,83	9 500	6 000	1,65	1216	1216 K
	140	33	65	25,5	1,25	8 500	6 000	2	2216 ETN9	2216 EKTN9
	170	39	88,4	33,5	1,5	7 500	5 300	4,2	1316	1316 K
	170	58	135	49	2,24	7 000	5 300	6,1	2316	2316 K
85	150	28	48,8	20,8	0,98	9 000	5 600	2,05	1217	1217 K
	150	36	58,5	23,6	1,12	8 000	5 600	2,5	2217	2217 K
	180	41	97,5	38	1,7	7 000	4 800	5	1317	1317 K
	180	60	140	51	2,28	6 700	4 800	7,05	2317	2317 K
90	160	30	57,2	23,6	1,08	8 500	5 300	2,5	1218	1218 K
	160	40	70,2	28,5	1,32	7 500	5 300	3,4	2218	2218 K
	190	43	117	44	1,93	6 700	4 500	5,8	1318	1318 K
	190	64	151	57	2,5	6 300	4 500	8,45	2318	2318 K
95	170	32	63,7	27	1,2	8 000	5 000	3,1	1219	1219 K
	170	43	83,2	34,5	1,53	7 000	5 000	4,1	2219	2219 K
	200	45	133	51	2,16	6 300	4 300	6,7	1319	1319 K
	200	67	165	64	2,75	6 000	4 500	9,8	2319 M	2319 KM
100	180	34	68,9	30	1,29	7 500	4 800	3,7	1220	1220 K
	180	46	97,5	40,5	1,76	6 700	4 800	5	2220	2220 K
	215	47	143	57	2,36	6 000	4 000	8,3	1320	1320 K
	215	73	190	80	3,25	5 600	4 000	12,5	2320	2320 K
110	200	38	88,4	39	1,6	6 700	4 300	5,15	1222	1222 K
	200	53	124	52	2,12	6 000	4 300	7,1	2222	2222 K
	240	50	163	72	2,75	5 300	3 600	12	1322 M	1322 KM
120	215	42	119	53	2,12	6 300	4 000	6,75	1224 M	1224 KM
130	230	46	127	58,5	2,24	5 600	3 600	8,3	1226 M	1226 KM

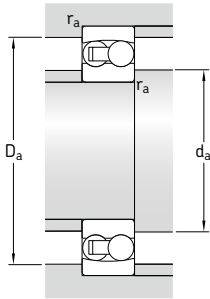

Dimensions				Abutment and fillet dimensions			Calculation factors				
d	d ₂	D ₁	r _{1,2} min.	d _a min.	D _a max.	r _a max.	k _r	e	Y ₁	Y ₂	Y ₀
mm				mm			-				
75	93	116	1,5	84	121	1,5	0,04	0,17	3,7	5,7	4
	91,6	118	1,5	84	121	1,5	0,045	0,22	2,9	4,5	2,8
	104	138	2,1	87	148	2	0,045	0,22	2,9	4,5	2,8
	97,8	139	2,1	87	148	2	0,05	0,37	1,7	2,6	1,8
80	101	125	2	91	129	2	0,04	0,16	3,9	6,1	4
	99	127	2	91	129	2	0,045	0,22	2,9	4,5	2,8
	109	147	2,1	92	158	2	0,045	0,22	2,9	4,5	2,8
	104	148	2,1	92	158	2	0,05	0,37	1,7	2,6	1,8
85	107	134	2	96	139	2	0,04	0,17	3,7	5,7	4
	105	133	2	96	139	2	0,04	0,25	2,5	3,9	2,5
	117	155	3	99	166	3	0,045	0,22	2,9	4,5	2,8
	115	157	3	99	166	3	0,05	0,37	1,7	2,6	1,8
90	112	142	2	101	149	2	0,04	0,17	3,7	5,7	4
	112	142	2	101	149	2	0,04	0,27	2,3	3,6	2,5
	122	165	3	104	176	3	0,045	0,22	2,9	4,5	2,8
	121	164	3	104	176	3	0,05	0,37	1,7	2,6	1,8
95	120	151	2,1	107	158	2	0,04	0,17	3,7	5,7	4
	118	151	2,1	107	158	2	0,04	0,27	2,3	3,6	2,5
	127	174	3	109	186	3	0,045	0,23	2,7	4,2	2,8
	128	172	3	109	186	3	0,05	0,37	1,7	2,6	1,8
100	127	159	2,1	112	168	2	0,04	0,17	3,7	5,7	4
	124	160	2,1	112	168	2	0,04	0,27	2,3	3,6	2,5
	136	185	3	114	201	3	0,045	0,23	2,7	4,2	2,8
	135	186	3	114	201	3	0,05	0,37	1,7	2,6	1,8
110	140	176	2,1	122	188	2	0,04	0,17	3,7	5,7	4
	137	177	2,1	122	188	2	0,04	0,28	2,2	3,5	2,5
	154	206	3	124	226	3	0,045	0,22	2,9	4,5	2,8
120	149	190	2,1	132	203	2	0,04	0,19	3,3	5,1	3,6
130	163	204	3	144	216	3	0,04	0,19	3,3	5,1	3,6

4.1 Self-aligning ball bearings d 150 – 240 mm

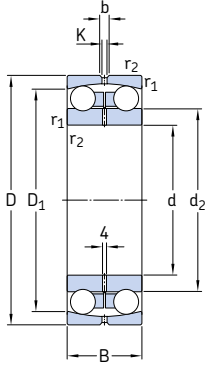

Principal dimensions		Basic load ratings		Fatigue load limit	Speed ratings		Mass	Designation	
d	D	dynamic	static	P_u	Reference speed	Limiting speed	kg	-	
mm	mm	kN	kN	kN	r/min	r/min	kg	-	
150	225	56	57,2	23,6	0,88	5 600	3 400	7,5	13030
180	280	74	95,6	40	1,34	4 500	2 800	16	13036
200	280	60	60,5	29	0,97	4 300	2 600	10,7	13940
220	300	60	60,5	30,5	0,97	3 800	2 400	11	13944
240	320	60	60,5	32	0,98	3 800	2 200	11,3	13948

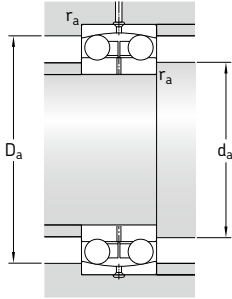

Dimensions					Abutment and fillet dimensions				Calculation factors				
d	d ₂	D ₁	b	K	r _{1,2} min.	d _a min.	D _a max.	r _a max.	k _r	e	Y ₁	Y ₂	Y ₀
mm						mm			-				
150	175	203	8,3	4,5	2,1	161	214	2	0,02	0,24	2,6	4,1	2,8
180	212	249	13,9	7,5	2,1	191	269	2	0,02	0,25	2,5	3,9	2,5
200	229	258	8,3	4,5	2,1	211	269	2	0,015	0,19	3,3	5,1	3,6
220	249	278	8,3	4,5	2,1	231	289	2	0,015	0,18	3,5	5,4	3,6
240	269	298	8,3	4,5	2,1	251	309	2	0,015	0,16	3,9	6,1	4

4.2 Sealed self-aligning ball bearings d 10 – 70 mm

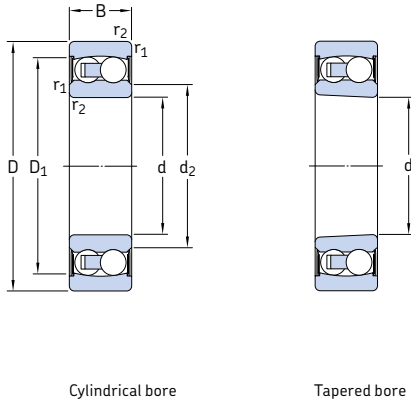

Cylindrical bore

Tapered bore

Principal dimensions			Basic load ratings		Fatigue load limit P_u	Limiting speed	Mass	Designations Bearing with cylindrical bore	tapered bore
d	D	B	C	C_0					
mm			kN		kN	r/min	kg	–	
10	30	14	5,53	1,18	0,06	17 000	0,048	2200 E-2RS1TN9	–
12	32	14	6,24	1,43	0,08	16 000	0,053	2201 E-2RS1TN9	–
15	35	14	7,41	1,76	0,09	14 000	0,058	2202 E-2RS1TN9	–
	42	17	10,8	2,6	0,14	12 000	0,11	2302 E-2RS1TN9	–
17	40	16	8,84	2,2	0,12	12 000	0,089	2203 E-2RS1TN9	–
	47	19	12,7	3,4	0,18	11 000	0,16	2303 E-2RS1TN9	–
20	47	18	12,7	3,4	0,18	10 000	0,14	2204 E-2RS1TN9	–
	52	21	14,3	4	0,21	9 000	0,21	2304 E-2RS1TN9	–
25	52	18	14,3	4	0,21	9 000	0,16	2205 E-2RS1TN9	2205 E-2RS1KTN9
	62	24	19	5,4	0,28	7 500	0,34	2305 E-2RS1TN9	2305 E-2RS1KTN9
30	62	20	15,6	4,65	0,24	7 500	0,26	2206 E-2RS1TN9	2206 E-2RS1KTN9
	72	27	22,5	6,8	0,36	6 700	0,51	2306 E-2RS1TN9	2306 E-2RS1KTN9
35	72	23	19	6	0,31	6 300	0,41	2207 E-2RS1TN9	2207 E-2RS1KTN9
	80	31	26,5	8,5	0,43	5 600	0,7	2307 E-2RS1TN9	2307 E-2RS1KTN9
40	80	23	19,9	6,95	0,36	5 600	0,5	2208 E-2RS1TN9	2208 E-2RS1KTN9
	90	33	33,8	11,2	0,57	5 000	0,96	2308 E-2RS1TN9	2308 E-2RS1KTN9
45	85	23	22,9	7,8	0,4	5 300	0,53	2209 E-2RS1TN9	2209 E-2RS1KTN9
	100	36	39	13,4	0,7	4 500	1,3	2309 E-2RS1TN9	2309 E-2RS1KTN9
50	90	23	22,9	8,15	0,42	4 800	0,57	2210 E-2RS1TN9	2210 E-2RS1KTN9
	110	40	43,6	14	0,72	4 000	1,65	2310 E-2RS1TN9	2310 E-2RS1KTN9
55	100	25	27,6	10,6	0,54	4 300	0,79	2211 E-2RS1TN9	2211 E-2RS1KTN9
60	110	28	31,2	12,2	0,62	3 800	1,05	2212 E-2RS1TN9	2212 E-2RS1KTN9
65	120	31	35,1	14	0,72	3 600	1,4	2213 E-2RS1TN9	2213 E-2RS1KTN9
70	125	31	35,8	14,6	0,75	3 400	1,45	2214 E-2RS1TN9	–

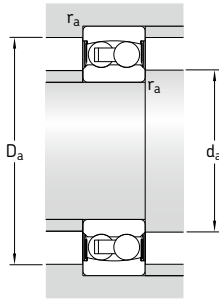

Dimensions				Abutment and fillet dimensions				Calculation factors				
d	d ₂	D ₁	r _{1,2}	d _a	d _a	D _a	r _a	k _r	e	Y ₁	Y ₂	Y ₀
mm	~	~	min.	min.	max.	max.	max.					
10	14	24,8	0,6	14	14	25,8	0,6	0,045	0,33	1,9	3	2
12	15,5	27,4	0,6	15,5	15,5	27,8	0,6	0,045	0,33	1,9	3	2
15	19,1	30,4	0,6	19	19	30,8	0,6	0,045	0,33	1,9	3	2
	20,3	36,3	1	20	20	36,4	1	0,05	0,31	2	3,1	2,2
17	21,1	35	0,6	21	21	35,8	0,6	0,045	0,31	2	3,1	2,2
	25,5	41,3	1	22	25,5	41,4	1	0,05	0,3	2,1	3,3	2,2
20	25,9	41,3	1	25	25,5	41,4	1	0,045	0,3	2,1	3,3	2,2
	28,6	46,3	1,1	26,5	28,5	45	1,1	0,05	0,28	2,2	3,5	2,5
25	31	46,3	1	30,6	31	46,4	1	0,045	0,28	2,2	3,5	2,5
	32,8	52,7	1,1	32	32,5	55	1,1	0,05	0,28	2,2	3,5	2,5
30	36,7	54,1	1	35,6	36,5	56,4	1	0,045	0,25	2,5	3,9	2,5
	40,4	61,9	1,1	37	40	65	1,1	0,05	0,25	2,5	3,9	2,5
35	42,7	62,7	1,1	42	42,5	65	1,1	0,045	0,23	2,7	4,2	2,8
	43,7	69,2	1,5	43,5	43,5	71	1,5	0,05	0,25	2,5	3,9	2,5
40	49	69,8	1,1	47	49	73	1,1	0,045	0,22	2,9	4,5	2,8
	55,4	81,8	1,5	49	55	81	1,5	0,05	0,23	2,7	4,2	2,8
45	53,1	75,3	1,1	52	53	78	1,1	0,045	0,21	3	4,6	3,2
	60,9	90	1,5	54	60,5	91	1,5	0,05	0,23	2,7	4,2	2,8
50	58,1	79,5	1,1	57	58	83	1,1	0,045	0,2	3,2	4,9	3,2
	62,9	95,2	2	61	62,5	99	2	0,05	0,24	2,6	4,1	2,8
55	65,9	88,5	1,5	64	65,5	91	1,5	0,045	0,19	3,3	5,1	3,6
60	73,2	97	1,5	69	73	101	1,5	0,045	0,19	3,3	5,1	3,6
65	79,3	106	1,5	74	79	111	1,5	0,045	0,18	3,5	5,4	3,6
70	81,4	109	1,5	79	81	116	1,5	0,045	0,18	3,5	5,4	3,6

4.3 Self-aligning ball bearings with an extended inner ring d 20 – 60 mm

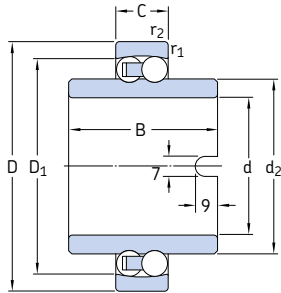

Principal dimensions			Basic load ratings		Fatigue load limit	Limiting speed	Mass	Designation
d	D	C	C	C ₀	P _u			
mm			kN		kN	r/min	kg	–
20	47	14	12,7	3,4	0,18	9 000	0,18	11204 ETN9
25	52	15	14,3	4	0,21	8 000	0,22	11205 ETN9
30	62	16	15,6	4,65	0,24	6 700	0,35	11206 TN9
35	72	17	19	6	0,305	5 600	0,54	11207 TN9
40	80	18	19	6,55	0,335	5 000	0,72	11208 TN9
45	85	19	22,9	7,8	0,4	4 500	0,77	11209 TN9
50	90	20	26,5	9,15	0,475	4 300	0,85	11210 TN9
60	110	22	31,2	12,2	0,62	3 400	1,15	11212 TN9

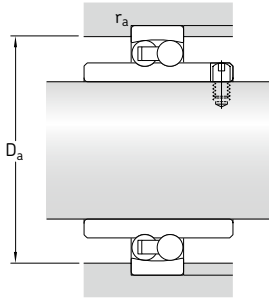

Dimensions					Abutment and fillet dimensions		Calculation factors				
d	d ₂ ~	D ₁ ~	B	r _{1,2} min.	D _a max.	r _a max.	k _r	e	Y ₁	Y ₂	Y ₀
mm							-				
20	28,9	41	40	1	41,4	1	0,04	0,3	2,1	3,3	2,2
25	33,3	45,6	44	1	46,4	1	0,04	0,28	2,2	3,5	2,5
30	40,1	53,2	48	1	56,4	1	0,04	0,25	2,5	3,9	2,5
35	47,7	60,7	52	1,1	65	1,1	0,04	0,23	2,7	4,2	2,8
40	54	68,8	56	1,1	73	1,1	0,04	0,22	2,9	4,5	2,8
45	57,7	73,7	58	1,1	78	1,1	0,04	0,21	3	4,6	3,2
50	62,7	78,7	58	1,1	83	1,1	0,04	0,21	3	4,6	3,2
60	78	97,5	62	1,5	101	1,5	0,04	0,19	3,3	5,1	3,6

4.4 Self-aligning ball bearings on an adapter sleeve

d_1 17 – 115 mm

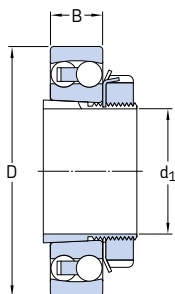

Open bearing on a standard sleeve

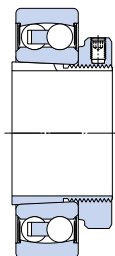

Sealed bearing on an E design sleeve

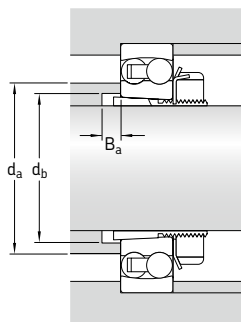

Principal dimensions			Abutment dimensions			Mass Bearing incl. sleeve	Designations Bearing ¹⁾	Adapter sleeve ²⁾
d_1	D	B	d_a max.	d_b min.	B_a min.			
mm			mm	mm		kg	-	
17	47	14	28,5	23	5	0,16	1204 EKTN9	H 204
20	52	15	33	28	5	0,21	1205 EKTN9	H 205
	52	18	31	28	5	0,23	2205 E-2RS1KTN9	H 305 E
	52	18	32	28	5	0,23	2205 EKTN9	H 305
	62	17	37	28	6	0,33	1305 EKTN9	H 305
	62	24	32,5	29	5	0,42	2305 E-2RS1KTN9	H 2305
	62	24	35,5	29	5	0,42	2305 EKTN9	H 2305
25	62	16	40	33	5	0,32	1206 EKTN9 ³⁾	H 206
	62	20	36,5	33	5	0,36	2206 E-2RS1KTN9	H 306 E
	62	20	38	33	5	0,36	2206 EKTN9	H 306
	72	19	44	33	6	0,49	1306 EKTN9	H 306
	72	27	40	35	5	0,62	2306 E-2RS1KTN9	H 2306
	72	27	41	35	5	0,61	2306 K	H 2306
30	72	17	47	38	5	0,44	1207 EKTN9 ³⁾	H 207
	72	23	42,5	39	5	0,55	2207 E-2RS1KTN9	H 307 E
	72	23	45	39	5	0,54	2207 EKTN9	H 307
	80	21	51	39	7	0,65	1307 EKTN9	H 307
	80	31	43,5	40	5	0,86	2307 E-2RS1KTN9	H 2307 E
	80	31	46	40	5	0,84	2307 EKTN9	H 2307
35	80	18	53	43	6	0,58	1208 EKTN9 ³⁾	H 208
	80	23	49	44	6	0,67	2208 E-2RS1KTN9	H 308 E
	80	23	52	44	6	0,58	2208 EKTN9	H 308
	90	23	61	44	6	0,85	1308 EKTN9	H 308
	90	33	55	45	6	1,2	2308 E-2RS1KTN9	H 2308
	90	33	53	45	6	1,1	2308 EKTN9	H 2308
40	85	19	57	48	6	0,68	1209 EKTN9 ³⁾	H 209
	85	23	53	50	8	0,76	2209 E-2RS1KTN9	H 309 E
	85	23	55	50	8	0,78	2209 EKTN9	H 309
	100	25	67	50	6	1,2	1309 EKTN9	H 309
	100	36	60,5	50	6	1,55	2309 E-2RS1KTN9	H 2309
	100	36	60	50	6	1,4	2309 EKTN9	H 2309

¹⁾ For additional bearing data → **product tables, page 552** (open bearings) and **page 560** (sealed bearings)

²⁾ For additional adapter sleeve data → **product tables, page 1290**

³⁾ Bearings and sleeves also available as KAM self-aligning ball bearing kits (→ **page 547**)

Principal dimensions			Abutment dimensions			Mass Bearing incl. sleeve	Designations Bearing ¹⁾	Adapter sleeve ²⁾
d ₁	D	B	d _a max.	d _b min.	B _a min.			
mm			mm			kg	-	
45	90	20	62	53	6	0,77	1210 EKTN9 ³⁾	H 210
	90	23	58	55	10	0,84	2210 E-2RS1KTN9	H 310 E
	90	23	61	55	10	0,87	2210 EKTN9	H 310
	110	27	70	55	6	1,45	1310 EKTN9	H 310
	110	40	62,5	56	6	2	2310 E-2RS1KTN9	H 2310
	110	40	65	56	6	1,9	2310 K	H 2310
50	100	21	70	60	7	0,99	1211 EKTN9 ³⁾	H 211
	100	25	65,5	60	11	1,1	2211 E-2RS1KTN9	H 311 E
	100	25	67	60	11	1,15	2211 EKTN9	H 311
	120	29	77	60	7	1,9	1311 EKTN9	H 311
	120	43	72	61	7	2,4	2311 K	H 2311
	55	110	22	78	64	7	1,2	1212 EKTN9
110		28	73	65	9	1,4	2212 E-2RS1KTN9	H 312 E
110		28	74	65	9	1,45	2212 EKTN9	H 312
130		31	87	65	7	2,15	1312 EKTN9	H 312
130		46	76	66	7	2,95	2312 K	H 2312
60	120	23	85	70	7	1,45	1213 EKTN9	H 213
	120	31	79	70	7	1,75	2213 E-2RS1KTN9	H 313 E
	120	31	80	70	9	1,8	2213 EKTN9	H 313
	140	33	98	70	7	2,85	1313 EKTN9	H 313
	140	48	85	72	7	3,6	2313 K	H 2313
	65	130	25	93	80	7	2	1215 K
130		31	93	80	13	2,3	2215 EKTN9	H 315
160		37	104	80	7	4,2	1315 K	H 315
160		55	97	82	7	5,55	2315 K	H 2315
70	140	26	101	85	7	2,4	1216 K	H 216
	140	33	99	85	13	2,85	2216 EKTN9	H 316
	170	39	109	85	7	5	1316 K	H 316
	170	58	104	88	7	7,1	2316 K	H 2316
75	150	28	107	90	8	2,95	1217 K	H 217
	150	36	105	91	13	3,3	2217 K	H 317
	180	41	117	91	8	6	1317 K	H 317
	180	60	111	94	8	8,15	2317 K	H 2317
80	160	30	112	95	8	3,5	1218 K	H 218
	160	40	112	96	11	5,5	2218 K	H 318
	190	43	122	96	8	6,9	1318 K	H 318
	190	64	115	100	8	9,8	2318 K	H 2318
85	170	32	120	100	8	4,25	1219 K	H 219
	170	43	118	102	10	5,3	2219 K	H 319
	200	45	127	102	8	7,9	1319 K	H 319
	200	67	128	105	8	11,5	2319 KM	H 2319
90	180	34	127	106	8	5	1220 K	H 220
	180	46	124	108	9	6,4	2220 K	H 320
	215	47	136	108	8	9,65	1320 K	H 320
	215	73	130	110	8	14	2320 K	H 2320
100	200	38	140	116	8	6,8	1222 K	H 222
	200	53	137	118	8	8,85	2222 K	H 322
	240	50	154	118	10	13,5	1322 KM	H 322
110	215	42	150	127	12	8,3	1224 KM	H 3024
115	230	46	163	137	15	11	1226 KM	H 3026

¹⁾ For additional bearing data → **product tables, page 552** (open bearings) and **page 560** (sealed bearings)

²⁾ For additional adapter sleeve data → **product tables, page 1290**

³⁾ Bearings and sleeves also available as KAM self-aligning ball bearing kits (→ **page 547**)



5 Cylindrical roller bearings



Designs and variants	568
Single row cylindrical roller bearings ..	570
Basic design bearings	570
Other variants	572
Other designs	574
High-capacity cylindrical roller bearings	575
Single row full complement cylindrical roller bearings	578
Double row full complement cylindrical roller bearings	579
Matched bearings	581
Cages	582
Performance classes	583
SKF Explorer bearings	583
SKF Energy Efficient (E2) bearings	583
Bearing data	584
(Dimension standards, tolerances, internal clearance, misalignment, axial displacement, friction, starting torque, power loss, defect frequencies)	
Loads	595
(Minimum load, equivalent loads)	
Dynamic axial load carrying capacity ..	596
Flange support	598
Temperature limits	599
Permissible speed	600
Mounting	601
Interchangeable components	601
High-capacity cylindrical roller bearings	601
Single row full complement cylindrical roller bearings, NJG design	601
Designation system	602

Product tables

5.1 Single row cylindrical roller bearings	604
5.2 High-capacity cylindrical roller bearings	640
5.3 Single row full complement cylindrical roller bearings	644
5.4 Double row full complement cylindrical roller bearings	656
5.5 Sealed double row full complement cylindrical roller bearings	668

Other cylindrical roller bearings

Bearings with Solid Oil	1185
SKF DryLube bearings	1191
INSOCOAT bearings	1205
Hybrid bearings	1219
NoWear coated bearings	1241
Super-precision cylindrical roller bearings	→ skf.com/super-precision
Multi-row cylindrical roller bearings for rolling mills	→ skf.com/bearings
Cylindrical roller bearings for railway axleboxes	→ contact SKF
Cylindrical roller bearings for traction motors	→ contact SKF
Backing bearings for cluster mills	→ skf.com/bearings
Indexing roller units for continuous furnaces	→ skf.com/bearings

Designs and variants

SKF cylindrical roller bearings are available in many designs, series and sizes. The majority are single row bearings with a cage. High-capacity bearings, single and double row full complement bearings (without a cage) complete the SKF standard assortment listed in this catalogue.

Bearings with a cage can accommodate heavy radial loads, rapid accelerations and high speeds. Full complement bearings incorporate a maximum number of rollers and are therefore suitable for very heavy radial loads at moderate speeds. SKF high-capacity cylindrical roller bearings combine the high load carrying capacity of a full complement bearing with the high speed capability of a bearing with a cage.

The factors that influence SKF cylindrical roller bearing performance and service life include but are not limited to the following:

More information

Bearing life and load ratings	63
Design considerations	159
Bearing systems	160
Recommended fits	169
Abutment and fillet dimensions	208
Lubrication	239
Mounting, dismantling and bearing care	271
Mounting instructions for individual bearings	→ skf.com/mount
<i>SKF bearing maintenance handbook</i>	(ISBN 978-91-978966-4-1)

- **Roller end / flange contact area**
SKF cylindrical roller bearings have two integral flanges on either the inner or outer ring to guide the rollers. The bearings have “open” flanges, i.e. the inward face of the flange is inclined by a defined angle (→ **fig. 1**). The flange design, together with the roller end design and surface finish, promote the formation of a lubricant film to reduce friction and frictional heat.

- **Logarithmic roller profile**
The roller profile determines the stress distribution in the roller/raceway contact area. As a result, the rollers in SKF cylindrical roller bearings have a logarithmic profile to distribute loads evenly along the rollers. This prevents stress peaks at the roller ends to extend bearing service life (→ **fig. 2**). The logarithmic profile also reduces sensitivity to misalignment and shaft deflection.

- **Surface finish**
The surface finish on the contact surfaces of the rollers and raceways maximizes the formation of a hydrodynamic lubricant film and optimizes the rolling motion of the rollers. The benefits derived from this, compared with traditional designs, include enhanced operational reliability.

- **Interchangeable components**
The separable components of same-sized SKF cylindrical roller bearings are interchangeable (→ **fig. 3**). Any bearing ring with a roller and cage assembly can be assembled with any removable ring of the same bearing type and size having the same internal clearance class. This is particularly important when bearings and their components must be mounted independently of each other.

Fig. 1

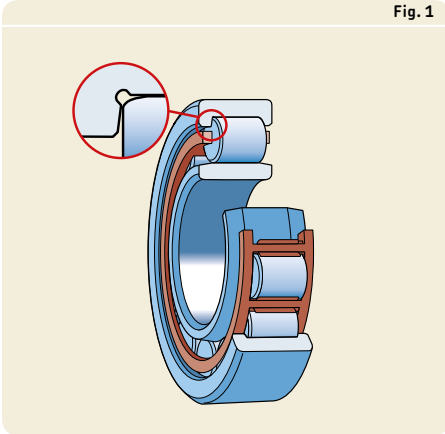

In addition to the bearings listed in this catalogue the comprehensive SKF assortment of cylindrical roller bearings includes:

- super-precision cylindrical roller bearings with steel rollers or hybrid bearings
- cylindrical roller bearings and bearing units for railway axleboxes
- cylindrical roller bearings for traction motors for railway applications
- multi-row cylindrical roller bearings for rolling mills
- backing bearings for cluster mills
- indexing roller units for continuous furnaces

5

For detailed information about these bearings, refer to the product information available online at skf.com/super-precision and skf.com/bearings or contact the SKF application engineering service.

Fig. 2

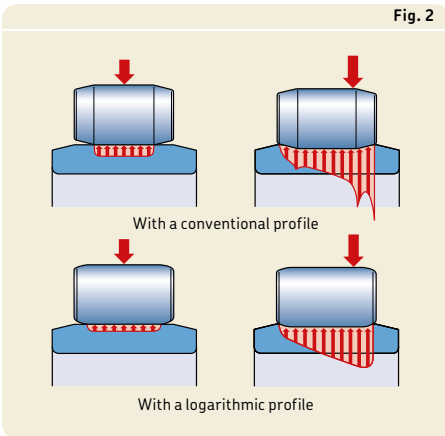
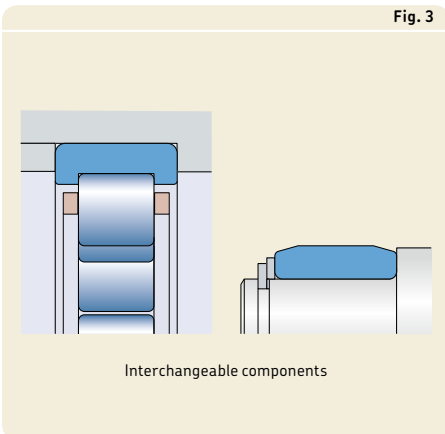

Fig. 3



5 Cylindrical roller bearings

Single row cylindrical roller bearings

Single row cylindrical roller bearings are separable, i.e. the bearing ring with the roller and cage assembly can be separated from the other ring. This simplifies mounting and dismounting, particularly when load conditions require both rings to have an interference fit.

Basic design bearings

SKF basic design single row cylindrical roller bearings are available in several designs. The main difference is the configuration of the flanges. The most popular designs (→ **fig. 4**) are listed in this catalogue and include:

- NU design
NU design bearings have two integral flanges on the outer ring and no flanges on the inner ring. These bearings can accommodate axial displacement of the shaft relative to the housing in both directions.
- N design
N design bearings have two integral flanges on the inner ring and no flanges on the outer ring. These bearings can accommodate axial displacement of the shaft relative to the housing in both directions.
- NJ design
NJ design bearings have two integral flanges on the outer ring and one on the inner ring. These bearings are used to locate the shaft axially in one direction. They can accommodate axial displacement of the shaft relative to the housing in one direction only.

- NUP design
NUP design bearings have two integral flanges on the outer ring and one integral flange and one non-integral flange i.e. a loose flange ring, on the inner ring. These bearings are used to locate the shaft axially in both directions.

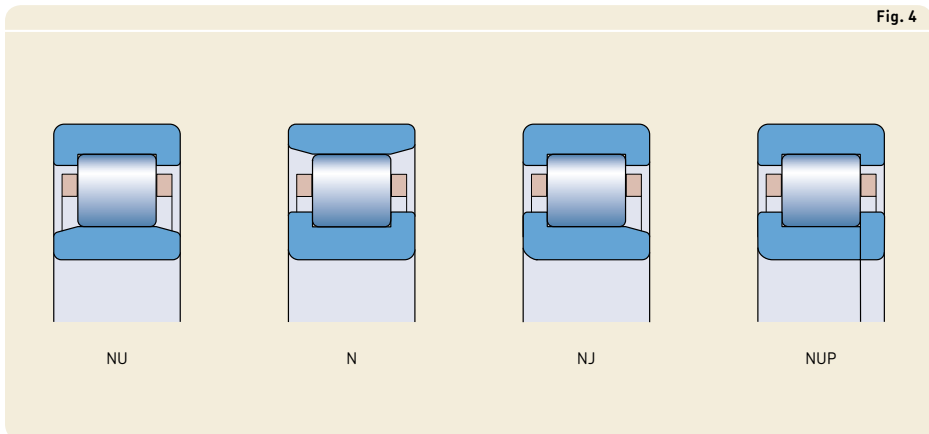

Angle rings (thrust collars)

To stabilize NU and NJ design bearings in the axial direction, SKF can supply angle rings (→ **fig. 5**). When used with an angle ring, NU design bearings locate the shaft axially in one direction. Angle rings should not be used on both sides of NU design bearings as this can lead to axial compression of the rollers. NJ design bearings combined with an angle ring are used to locate the shaft axially in both directions.

There can be several reasons to design angle rings into a bearing arrangement:

- When NJ or NUP design locating bearings are not in the product range.
- To provide a more effective inner ring seat for heavily loaded bearings in the locating position. An arrangement of an NJ design bearing with an HJ angle ring have a full width inner ring seat, instead of using an NUP design bearing that has a shorter inner ring and a loose flange.
- To simplify design or mounting procedures.

SKF angle rings are made of carbon chromium steel. They are hardened and ground. The maximum axial run-out is in accordance with the Normal tolerance class for the appropriate bearing. Available angle rings are listed in the product tables. They are identified by the series designation HJ followed by the appropriate bearing dimension series and size. Angle rings must be ordered separately.

Fig. 5

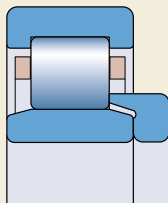

NU + HJ angle ring

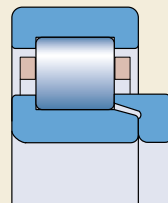

NJ + HJ angle ring

5 Cylindrical roller bearings

Other variants

Bearings without an inner or outer ring

SKF can supply NU design cylindrical roller bearings without an inner ring (RNU series, → **fig. 6**) and N design bearings without an outer ring (RN series, → **fig. 6**). These bearings are typically used in applications where hardened and ground raceways are provided on the shaft or in the housing (→ *Raceways on shafts and in housings*, **page 210**). Because RNU bearings do not have an inner ring, the shaft diameter can be larger to provide a stronger, stiffer shaft arrangement. Additionally, the possible axial displacement of the shaft relative to the housing is limited only by the width of the raceway on the shaft for RNU bearings, or in the housing for RN bearings.

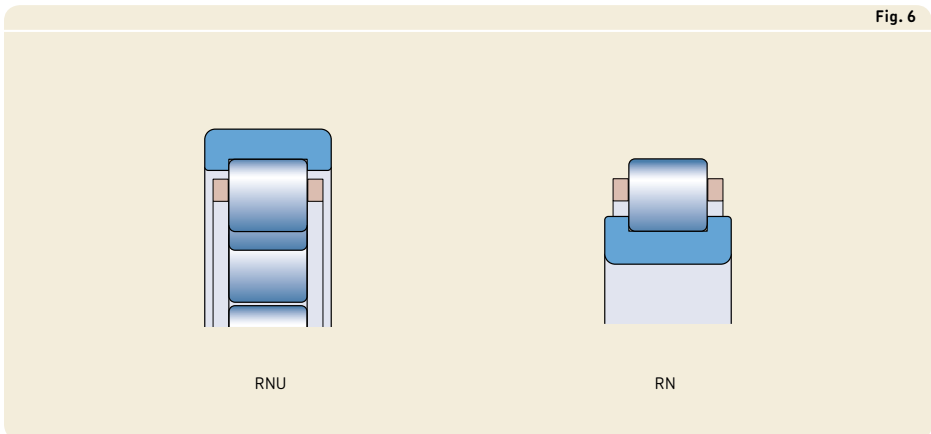

Bearings with a tapered bore

Some single row cylindrical roller bearings can be supplied with a 1:12 tapered bore (designation suffix K, → **fig. 7**). Bearings with a tapered bore have radial internal clearance greater than corresponding bearings with a cylindrical bore. For additional information, refer to the product information available online at skf.com/bearings or contact the SKF application engineering service. Check availability prior to ordering.

Bearings with a snap ring groove

Single row cylindrical roller bearings can be supplied with a snap ring groove in the outer ring (designation suffix N, → **fig. 8**). These bearings can be axially located in the housing by a snap ring to save space and reduce installation time. The dimensions of the snap rings and snap ring grooves are in accordance with ISO 464. Check availability prior to ordering.

Bearings with locating slots

When the outer ring must be mounted with a loose fit, bearings with locating slots can be used to prevent the outer ring from turning. Single row cylindrical roller bearings can be supplied with one or two locating slots (designation suffix N1 or N2) in the outer ring (→ **fig. 9**). The two locating slots are positioned 180° apart. The dimensions of the locating slots are in accordance with ISO 20515. Check availability prior to ordering.

Fig. 7

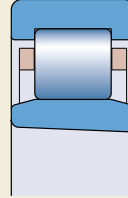

Fig. 8

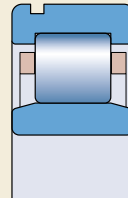
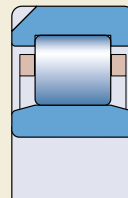

Fig. 9



5 Cylindrical roller bearings

Other designs

SKF single row cylindrical roller bearings can have the extended inner ring or flange configurations shown in **fig. 10**. For additional information about these bearings and customized designs, refer to the product information available online at skf.com/bearings or contact the SKF application engineering service.

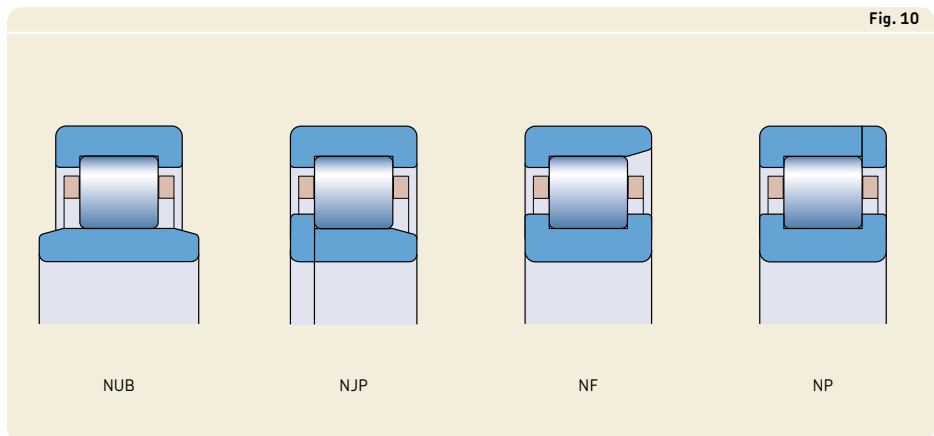

High-capacity cylindrical roller bearings

SKF high-capacity cylindrical roller bearings (→ **fig. 11**) have the high load carrying capacity of full complement bearings and the high speed capability of bearings with a cage. They are designed for applications such as industrial gearboxes, gearboxes in wind turbines and mining equipment.

The superior performance of SKF high-capacity cylindrical roller bearings is mainly a result of the cage design. The window-type metal cage is designed so that its cage bars are displaced relative to the roller pitch diameter. This enables the rollers to be placed closer to each other, creating room for additional rollers (→ **fig. 12**). Depending on the bearing series, the cage can be either inner or outer ring centred. These cages are beneficial if high speeds, rapid accelerations or shock loads occur.

The rings and rollers in SKF high-capacity cylindrical roller bearings are coated with black oxide (designation suffix L4B) to minimize the risk of smearing or wear, especially during the running-in period.

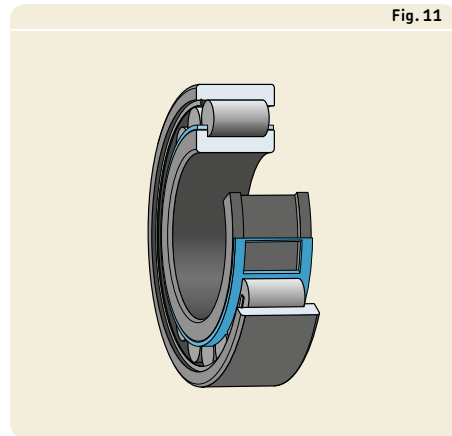

Fig. 11

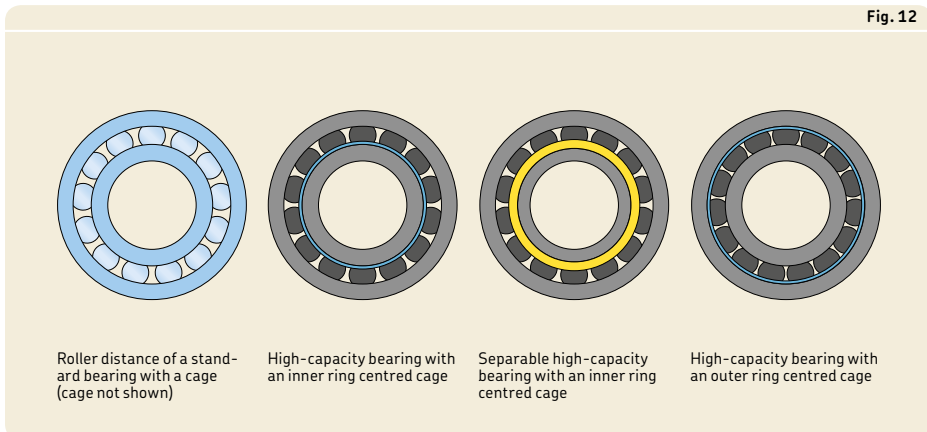

Fig. 12

Roller distance of a standard bearing with a cage (cage not shown)

High-capacity bearing with an inner ring centred cage

Separable high-capacity bearing with an inner ring centred cage

High-capacity bearing with an outer ring centred cage

5 Cylindrical roller bearings

Bearings with an inner ring centred cage

SKF high-capacity cylindrical roller bearings with an inner ring centred cage (→ **fig. 13**) are identified by the series designation NCF .. ECJB (→ **product tables**). They are used to locate the shaft axially in one direction and eventually to accommodate axial displacement of the shaft relative to the housing in the opposite direction.

When the outer raceway is integrated into the application, these bearings can be supplied without an outer ring (RN .. ECJB series).

Bearings with an outer ring centred cage

SKF high-capacity cylindrical roller bearings with an outer ring centred cage (→ **fig. 14**) are identified by the series designation NJF .. ECJA. For some sizes, the bearings contain more rollers than same-sized bearings with an inner ring centred cage. They are used to locate the shaft axially in one direction and eventually to accommodate axial displacement of the shaft relative to the housing in the opposite direction. For additional information, contact the SKF application engineering service.

When the inner raceway is integrated into the application, these bearings can be supplied without an inner ring (RNU .. ECJA series).

Fig. 13

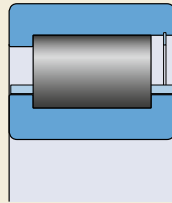

NCF .. ECJB

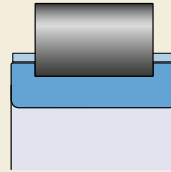

RN .. ECJB

Fig. 14

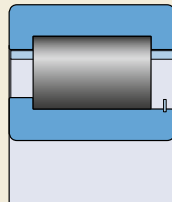

NJF .. ECJA

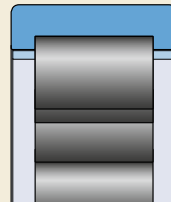

RNU .. ECJA

Separable bearings with an inner ring centred cage

SKF separable high-capacity cylindrical roller bearings with an inner ring centred cage (→ **fig. 15**) are identified by the series designation NUH .. ECMH (→ **product tables**). The bearing outer ring with the roller and cage assembly can be separated from the inner ring. This simplifies mounting and dismounting, particularly when load conditions require both rings to have an interference fit. These bearings can accommodate axial displacement of the shaft relative to the housing in both directions.

Double row bearings

Double row SKF high-capacity cylindrical roller bearings with cages can be supplied on request. They are based on the design of double row full complement bearings (→ **page 579**, e.g. NNCF design). For additional information, contact the SKF application engineering service.

Fig. 15

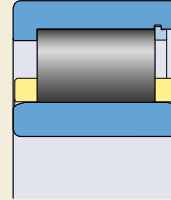

NUH .. ECMH

5 Cylindrical roller bearings

Single row full complement cylindrical roller bearings

The basic SKF assortment of single row full complement cylindrical roller bearings listed in this catalogue includes NCF and NJG design bearings (→ **fig. 16**). They are used to locate the shaft axially in one direction and eventually to accommodate axial displacement of the shaft relative to the housing in the opposite direction.

NCF design

NCF design bearings have two integral flanges on the inner ring and one on the outer ring. A retaining ring inserted in the outer ring on the side opposite the integral flange holds the bearing together. The retaining ring should not be loaded axially during operation.

NJG design

NJG design bearings, which comprise the heavy 23 dimension series, are intended for very heavily loaded, slow-speed applications. These bearings have two integral flanges on the outer ring and one on the inner ring. NJG design bearings have a self-retaining roller complement. Therefore, the outer ring with the roller complement can be separated from the inner ring without having to take special precautions to prevent the rollers from falling out. This simplifies mounting and dismounting.

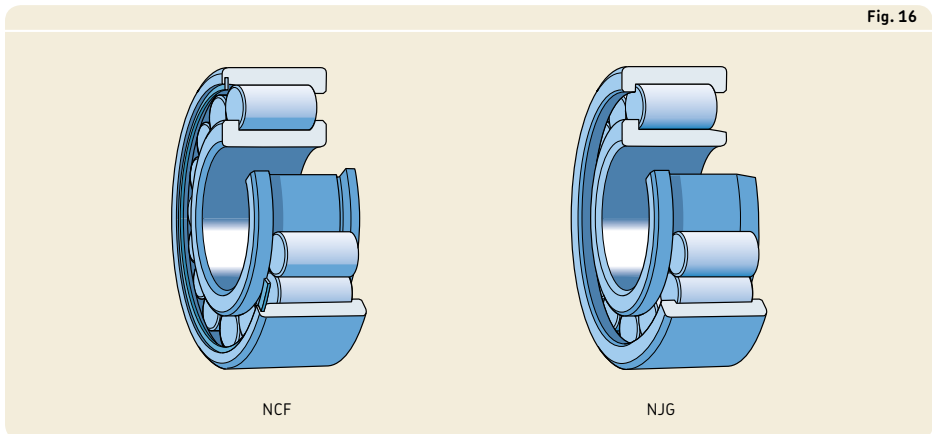

Fig. 16

Double row full complement cylindrical roller bearings

The basic SKF assortment of double row full complement cylindrical roller bearings listed in this catalogue includes NNCL, NNCF and NNC open design bearings, as well as sealed NNF design bearings (→ **fig. 17**). All bearings are non-separable and have an annular groove and three lubrication holes in the outer ring to facilitate lubrication. NNF design bearings have three additional lubrication holes in the inner ring.

NNCL design

NNCL design bearings have three integral flanges on the inner ring and no flanges on the outer ring. A retaining ring inserted in the outer ring between the roller rows holds the bearing together. The retaining ring should not be loaded axially during operation. These bearings can accommodate axial displacement of the shaft relative to the housing in both directions.

NNCF design

NNCF design bearings have three integral flanges on the inner ring and one on the outer ring to locate the shaft axially in one direction. A retaining ring inserted in the outer ring on the side opposite the integral flange holds the bearing together. The retaining ring should not be loaded axially during operation. These bearings are used to locate the shaft axially in one direction and eventually to accommodate axial displacement of the shaft relative to the housing in the opposite direction.

NNC design

NNC design bearings have the same inner ring as NNCL and NNCF design bearings. The two-piece outer ring is held together by retaining elements, which should never be loaded axially. Both parts of the outer ring are identical and have one integral flange. These bearings are used to locate the shaft axially in both directions.

Fig. 17

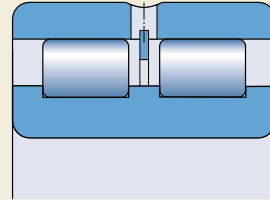

NNCL

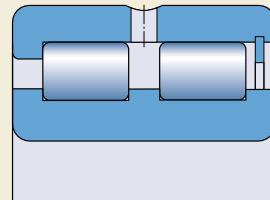

NNCF

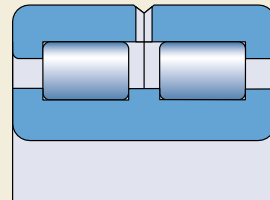

NNC

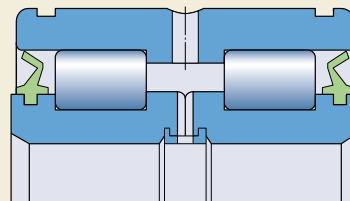

NNF

5 Cylindrical roller bearings

NNF design (sealed bearings)

NNF design bearings in the 50 and 3194.. series have a two-piece inner ring, held together by a retaining ring. The inner ring has three integral flanges and the outer ring has one integral central flange. The bearings are used to locate a shaft axially in both directions. The distance between the two rows of rollers enables these bearings to accommodate tilting moments.

The outer ring of an NNF design bearing is 1 mm narrower than the inner ring. In applications with a rotating outer ring, there is no need for spacer rings between the inner ring and adjacent components. The outer ring has two snap ring grooves to simplify installation and save space axially, when the bearing is mounted in/on an adjacent component, e.g. in rope sheaves (→ **fig. 18**).

The bearings have a contact PUR seal on both sides. Each seal is fitted in a recess on the inner ring shoulder (→ **fig. 17**, **page 579**). The seal lip exerts slight pressure against the outer ring raceway. The bearings are filled with a high-quality grease with good rust inhibiting properties (→ **table 1**). For additional information about greases, refer to *Lubrication* (→ **page 239**).

For applications where oil lubrication is to be used, the bearings can be supplied open and without grease. If a small quantity of bearings without seals is required, the seals can be removed and the bearings can be washed prior to installation.

Fig. 18

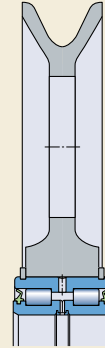

Table 1

Technical specifications of SKF standard greases for sealed double row full complement cylindrical roller bearings

Bearing series	Temperature range ¹⁾	Thickener	Base oil type	NLGI consistency class	Base oil viscosity [mm ² /s]	
					at 40°C (105 °F)	at 100°C (210 °F)
NNF 50 ADA		Lithium soap	Diester	2	15	3,7
NNF 50 ADB 3194 .. DA		Lithium complex soap	Mineral	2	160	15,5

¹⁾ Refer to the SKF traffic light concept → **page 244**

Relubrication of sealed bearings

For many application conditions, sealed double row full complement cylindrical roller bearings do not require relubrication and can be considered relubrication-free (→ *Relubrication*, **page 252**). However, if they operate in a moist or contaminated environment, or if speeds are moderate to high, relubrication may be necessary. The bearings can be relubricated via lubrication holes in both the inner and outer rings.

Matched bearings

SKF can supply matched bearings. To match bearings, SKF combines bearings so that the difference in cross-section height lies within a very small tolerance range. This reduced tolerance range is a precondition for equal load sharing between the bearings.

Matched bearings are identified by a designation suffix:

- DR for a set of two bearings
- TR for a set of three bearings
- QR for a set of four bearings

The bearings in a matched set can be single row or double row bearings. For additional information, contact the SKF application engineering service.

5 Cylindrical roller bearings

Cages



SKF single row and high-capacity cylindrical roller bearings are fitted, depending on their design, series and size, with one of the cages shown in **table 2**.

A large number of single row cylindrical roller bearings included in the SKF standard assortment are available as standard with more than one cage design (→ **product tables**).

The lubricants generally used for rolling bearings do not have a detrimental effect on cage properties. However, some synthetic oils and greases with a synthetic oil base and lubricants containing a high proportion of EP additives, when used at high temperatures, can have a detrimental effect on polyamide

cages. For additional information about the suitability of cages, refer to *Cages* (→ **page 37**) and *Cage materials* (→ **page 152**).

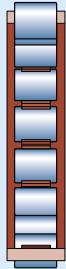
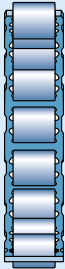
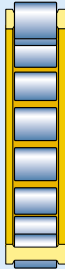
Table 2

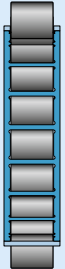
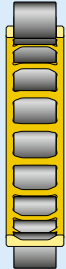
	Cages for single row cylindrical roller bearings				Cages for high-capacity cylindrical roller bearings	
						
Cage type	Window-type, roller or outer ring centred		Window-type, depending on bearing design inner or outer ring centred	Riveted • roller centred • outer ring centred • inner ring centred	Window-type, inner ring centred	
Material	<ul style="list-style-type: none"> • PA66, glass fibre reinforced • PEEK, glass fibre reinforced 	Stamped steel	Machined brass		Sheet steel, manganese phosphated	Machined brass
Suffix	<ul style="list-style-type: none"> • P or PA • PH or PHA 	<ul style="list-style-type: none"> • – • J 	• ML	<ul style="list-style-type: none"> • M • MA • MB 	• JB	• MH

Performance classes

SKF Explorer bearings

In response to the ever-demanding performance requirements of modern machinery, SKF developed the SKF Explorer performance class of rolling bearings.

SKF Explorer cylindrical roller bearings realized this substantial improvement in performance by optimizing the internal geometry and surface finish of all contact surfaces, combining the extremely clean and homogenous steel with a unique heat treatment, optimizing the roller end / flange contact area and applying an advanced logarithmic contact profile to the rollers and raceways.

These improvements provide the following benefits:

- higher dynamic load carrying capacity
- reduced sensitivity to misalignment
- improved wear-resistance
- reduced noise and vibration levels
- less frictional heat
- significantly extended bearing service life

SKF Explorer bearings reduce environmental impact by enabling downsizing and reducing both lubricant and energy use. Just as importantly, SKF Explorer bearings can reduce the need for maintenance and contribute to increased productivity.

SKF Explorer bearings are shown with an asterisk in the product tables. The bearings retain the designation of earlier standard bearings. However, each bearing and its box are marked with the name “SKF Explorer”.

Some cylindrical roller bearings are available as standard and as SKF Explorer bearings. Those SKF Explorer bearings are identified by the designation suffix PEX.

SKF Energy Efficient (E2) bearings

To meet the ever-increasing demand to reduce friction and energy use, SKF has developed the SKF Energy Efficient (E2) performance class of rolling bearings. NJ design cylindrical roller bearings within this performance class that are axially loaded are characterized by a frictional moment in the bearing that is up to 85% lower when compared to a same-sized standard SKF bearing and an increased axial load carrying capacity (ratio F_a/F_r up to 0,6). The heavier the axial load, the higher the advantage in frictional moment compared to standard or SKF Explorer bearings.

Reduced operating temperatures improve lubrication conditions and enable extended lubrication intervals or higher speeds. The improved roller end / flange contact in the bearing reduces the risk of skidding and smearing. Typical applications include wind energy transmissions, industrial transmissions and other applications with combined loads.

SKF E2 single row cylindrical roller bearings are available in the NJ design on request. For additional information, contact the SKF application engineering service.

Bearing data

	Single row cylindrical roller bearings
Dimension standards	Boundary dimensions: ISO 15 HJ angle rings: ISO 246
Tolerances	Normal dimensional accuracy P6 running accuracy
For additional information (→ page 132)	Values: ISO 492 (→ tables 3 and 4, pages 137 and 138)
Radial internal clearance	Normal, C3 Check availability of other clearance classes Values: ISO 5753-1 (→ table 3, page 590)
For additional information (→ page 149)	Values are valid for unmounted bearings under zero measuring load.
Axial internal clearance	Guideline values <ul style="list-style-type: none"> • NUP design (→ table 4, page 591) • NJ design with an HJ angle ring (→ table 5, page 592)
For additional information (→ page 149)	When measuring the axial internal clearance the rollers may tilt, causing an enlargement of the measured axial clearance: <ul style="list-style-type: none"> • 2, 3 and 4 series: ≈ the radial internal clearance • 22 and 23 series: ≈ 2/3 the radial internal clearance

→

Bearing data, continued

	Single row cylindrical roller bearings
Misalignment	<p>Guideline values</p> <ul style="list-style-type: none"> • 10, 12, 2, 3 and 4 series: ≈ 4 minutes of arc • 20, 22 and 23 series: ≈ 3 minutes of arc <p>The values are not valid for bearings of the NUP design or the NJ design with an HJ angle ring. Axial stresses may be induced in the bearings, because they have two inner and two outer ring flanges and the axial internal clearance is relatively small.</p> <p>The guideline values apply to non-locating bearings, provided the positions of the shaft and housing axes remain constant. Larger misalignment may be possible but may cause shorter bearing service life.</p> <p>The permissible angular misalignment between the inner and outer rings depends on the size and internal design of the bearing, the radial internal clearance in operation and the forces and moments acting on the bearing. As a result, only approximate values are listed here. Any misalignment increases bearing noise and reduces bearing service life.</p> <p>For additional information, contact the SKF application engineering service.</p>
Axial displacement	<p>Bearings having no flange on either the inner or outer ring, or only one integral flange on the inner or outer ring can accommodate axial displacement of the shaft relative to the housing within certain limits (\rightarrow product tables). There is virtually no increase in friction when the bearing rotates, because the axial displacement takes place within the bearing and not between the bearing and shaft or housing bore.</p>
Friction, starting torque, power loss	<p>Frictional moment, starting torque and power loss can be calculated as specified under <i>Friction</i> (\rightarrow page 97), or using the tools available online at skf.com/bearingcalculator.</p>
Defect frequencies	<p>Defect frequencies can be calculated using the tools available online at skf.com/bearingcalculator.</p>

Bearing data

	High-capacity cylindrical roller bearings	Single row full complement cylindrical roller bearings
Dimension standards	Boundary dimensions: ISO 15	
Tolerances	Normal dimensional accuracy P6 running accuracy	Normal
For additional information (→ page 132)	Values: ISO 492 (→ tables 3 and 4, pages 137 and 138)	
Radial internal clearance	Normal, C3 Check availability of other clearance classes Values: ISO 5753-1 (→ table 3, page 590) Values are valid for unmounted bearings under zero measuring load.	
For additional information (→ page 149)		
Axial internal clearance	–	
For additional information (→ page 149)		
Misalignment	Guideline value: ≈ 3 minutes of arc	Guideline values <ul style="list-style-type: none"> • 18 series: ≈ 4 minutes of arc • 22, 23, 28, 29 and 30 series: ≈ 3 minutes of arc
	<p>The guideline values apply to non-locating bearings, provided the positions of the shaft and housing axes remain constant. Larger misalignments may be possible but may cause shorter bearing service life.</p> <p>The permissible angular misalignment between the inner and outer rings depends on the size and internal design of the bearing, the ...</p>	

Double row full complement cylindrical roller bearings

Boundary dimensions: ISO 15, except for

- outer ring width of NNF 50 series bearings (C = 1 mm smaller than ISO standard)
- bearings in the 3194.. series (dimensions not standardized)

NNC and NNF designs: 0,1 to 0,2 mm

–

... radial internal clearance in operation and the forces and moments acting on the bearing. As a result, only approximate values are listed here. Any misalignment increases bearing noise and reduces bearing service life.

For additional information, contact the SKF application engineering service.

→ page 588

Bearing data, continued

	High-capacity cylindrical roller bearings	Single row full complement cylindrical roller bearings
Axial displacement	Bearings having no flange on either the inner or outer ring, or only one flange on the inner or outer ring can accommodate axial displacement of the shaft relative to the housing within certain limits ...	
Friction, starting torque, power loss	Frictional moment, starting torque and power loss can be calculated as specified under <i>Friction</i> (→ page 97), or using the tools available ...	
Defect frequencies	Defect frequencies can be calculated using the tools available online ...	

Double row full complement cylindrical roller bearings

... (→ **product tables**). There is virtually no increase in friction when the bearing rotates, because the axial displacement takes place within the bearing and not between the bearing and shaft or housing bore.

...online at skf.com/bearingcalculator.

... at skf.com/bearingcalculator.

5 Cylindrical roller bearings

Table 3

Radial internal clearance of cylindrical roller bearings with a cylindrical bore

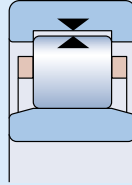

Bore diameter d		Radial internal clearance									
over	incl.	C2		Normal		C3		C4		C5	
		min.	max.	min.	max.	min.	max.	min.	max.	min.	max.
mm		µm									
–	24	0	25	20	45	35	60	50	75	65	90
24	30	0	25	20	45	35	60	50	75	70	95
30	40	5	30	25	50	45	70	60	85	80	105
40	50	5	35	30	60	50	80	70	100	95	125
50	65	10	40	40	70	60	90	80	110	110	140
65	80	10	45	40	75	65	100	90	125	130	165
80	100	15	50	50	85	75	110	105	140	155	190
100	120	15	55	50	90	85	125	125	165	180	220
120	140	15	60	60	105	100	145	145	190	200	245
140	160	20	70	70	120	115	165	165	215	225	275
160	180	25	75	75	125	120	170	170	220	250	300
180	200	35	90	90	145	140	195	195	250	275	330
200	225	45	105	105	165	160	220	220	280	305	365
225	250	45	110	110	175	170	235	235	300	330	395
250	280	55	125	125	195	190	260	260	330	370	440
280	315	55	130	130	205	200	275	275	350	410	485
315	355	65	145	145	225	225	305	305	385	455	535
355	400	100	190	190	280	280	370	370	460	510	600
400	450	110	210	210	310	310	410	410	510	565	665
450	500	110	220	220	330	330	440	440	550	625	735
500	560	120	240	240	360	360	480	480	600	690	810
560	630	140	260	260	380	380	500	500	620	780	900
630	710	145	285	285	425	425	565	565	705	865	1005
710	800	150	310	310	470	470	630	630	790	975	1135
800	900	180	350	350	520	520	690	690	860	1095	1265

Table 4

Axial internal clearance of NUP cylindrical roller bearings

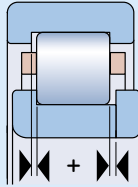

Bearing Bore diameter	Size code	Axial internal clearance of bearings in the series							
		NUP 2		NUP 3		NUP 22		NUP 23	
mm	μm	min.	max.	min.	max.	min.	max.	min.	max.
17	03	37	140	37	140	37	140	47	155
20	04	37	140	37	140	47	155	47	155
25	05	37	140	47	155	47	155	47	155
30	06	37	140	47	155	47	155	47	155
35	07	47	155	47	155	47	155	62	180
40	08	47	155	47	155	47	155	62	180
45	09	47	155	47	155	47	155	62	180
50	10	47	155	47	155	47	155	62	180
55	11	47	155	62	180	47	155	62	180
60	12	47	155	62	180	62	180	87	230
65	13	47	155	62	180	62	180	87	230
70	14	47	155	62	180	62	180	87	230
75	15	47	155	62	180	62	180	87	230
80	16	47	155	62	180	62	180	87	230
85	17	62	180	62	180	62	180	87	230
90	18	62	180	62	180	62	180	87	230
95	19	62	180	62	180	62	180	87	230
100	20	62	180	87	230	87	230	120	315
105	21	62	180	–	–	–	–	–	–
110	22	62	180	87	230	87	230	120	315
120	24	62	180	87	230	87	230	120	315
130	26	62	180	87	230	87	230	120	315
140	28	62	180	87	230	87	230	120	315
150	30	62	180	–	–	87	230	120	315
160	32	87	230	–	–	–	–	–	–
170	34	87	230	–	–	–	–	–	–
180	36	87	230	–	–	–	–	–	–
190	38	87	230	–	–	–	–	–	–
200	40	87	230	–	–	–	–	–	–
220	44	95	230	–	–	–	–	–	–
240	48	95	250	–	–	–	–	–	–
260	52	95	250	–	–	–	–	–	–

5 Cylindrical roller bearings

Table 5

Axial internal clearance of NJ + HJ cylindrical roller bearings

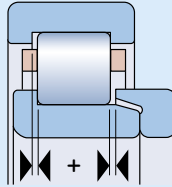

Bearing Bore diameter	Size code	Axial internal clearance of bearings in the series									
		NJ 2 + HJ 2		NJ 3 + HJ 3		NJ 4 + HJ 4		NJ 22 + HJ 22		NJ 23 + HJ 23	
mm	μm	min.	max.	min.	max.	min.	max.	min.	max.	min.	max.
20	04	42	165	42	165	–	–	52	185	52	183
25	05	42	165	52	185	–	–	52	185	52	183
30	06	42	165	52	185	60	200	52	185	52	183
35	07	52	185	52	185	60	200	52	185	72	215
40	08	52	185	52	185	60	200	52	185	72	215
45	09	52	185	52	185	60	200	52	185	72	215
50	10	52	185	52	185	80	235	52	185	72	215
55	11	52	185	72	215	80	235	52	185	72	215
60	12	52	185	72	215	80	235	72	215	102	275
65	13	52	185	72	215	80	235	72	215	102	275
70	14	52	185	72	215	80	235	72	215	102	275
75	15	52	185	72	215	80	235	72	215	102	275
80	16	52	185	72	215	80	235	72	215	102	275
85	17	72	215	72	215	110	290	72	215	102	275
90	18	72	215	72	215	110	290	72	215	102	275
95	19	72	215	72	215	110	290	72	215	102	275
100	20	72	215	102	275	110	290	102	275	140	375
105	21	72	215	102	275	110	290	102	275	140	375
110	22	72	215	102	275	110	290	102	275	140	375
120	24	72	215	102	275	110	310	102	275	140	375
130	26	72	215	102	275	110	310	102	275	140	375
140	28	72	215	102	275	140	385	102	275	140	375
150	30	72	215	102	275	140	385	102	275	140	375
160	32	102	275	102	275	–	–	140	375	140	375
170	34	102	275	–	–	–	–	140	375	–	–
180	36	102	275	–	–	–	–	140	375	–	–
190	38	102	275	–	–	–	–	–	–	–	–
200	40	102	275	–	–	–	–	–	–	–	–
220	44	110	290	–	–	–	–	–	–	–	–
240	48	110	310	–	–	–	–	–	–	–	–
260	52	110	310	–	–	–	–	–	–	–	–
280	56	110	310	–	–	–	–	–	–	–	–

For bearings not listed, contact the SKF application engineering service.

Table 6

Conversion factors for the minimum load factor k_r of single row cylindrical roller bearings

Bearing with standard cage	alternative standard cage	
	P, PH, J, M, MR	PA, PHA, MA, ML
P, PH, J, M, MR	1	1,5
PA, PHA, MA, ML	0,67	1

Table 7

Calculation factors for cylindrical roller bearings

Bearing dimension series	Limiting value e	Axial load factor Y
10, 18, 2, 3, 4	0,2	0,6
22, 23, 28, 29, 30	0,3	0,4

Loads

	Single row cylindrical roller bearings	High-capacity cylindrical roller bearings
<p>Minimum load</p> <p>For additional information (→ page 86)</p>	$F_{rm} = k_r \left(6 + \frac{4 n}{n_r} \right) \left(\frac{d_m}{100} \right)^2$ <p>The weight of the components supported by the bearing, together with external forces, generally exceed the requisite minimum load. If this is not the case, the bearing must be subjected to an additional radial load.</p>	
<p>Equivalent dynamic bearing load</p> <p>For additional information (→ page 85)</p>	<p>Non-locating bearings $P = F_r$</p> <p>Locating bearings</p> <p>$F_a/F_r \leq e$ → $P = F_r$</p> <p>$F_a/F_r > e$ → $P = 0,92 F_r + Y F_a$</p> <p>F_a must not exceed $0,5 F_r$.</p>	<p>$F_a/F_r \leq 0,3$ → $P = F_r$</p> <p>$F_a/F_r > 0,3$ → $P = 0,92 F_r + 0,4 F_a$</p> <p>F_a must not exceed $0,5 F_r$.</p>
<p>Equivalent static bearing load</p> <p>For additional information (→ page 88)</p>	$P_0 = F_r$	

Single row full complement cylindrical roller bearings	Double row full complement cylindrical roller bearings	Symbols
$F_a/F_r \leq e$ $\rightarrow P = F_r$ $F_a/F_r > e$ $\rightarrow P = 0,92 F_r + Y F_a$ F_a must not exceed $0,5 F_r$.	$F_a/F_r \leq 0,15$ $\rightarrow P = F_r$ $F_a/F_r > 0,15$ $\rightarrow P = 0,92 F_r + 0,4 F_a$ F_a must not exceed $0,25 F_r$.	d_m = bearing mean diameter [mm] $= 0,5 (d + D)$ e = limiting value (→ table 7, page 593) F_a = axial load [kN] F_r = radial load [kN] F_{rm} = minimum radial load [kN] k_r = minimum load factor (→ product tables and table 6, page 593) n = rotational speed [r/min] n_r = reference speed [r/min] (→ product tables) For sealed double row full complement bearings with seals removed and oil lubrication: use 1,3 times the limiting speed P = equivalent dynamic bearing load [kN] P_0 = equivalent static bearing load [kN] Y = axial load factor (→ table 7, page 593)

Dynamic axial load carrying capacity

Cylindrical roller bearings with flanges on both the inner and outer rings can support axial loads in addition to radial loads. F_a must not exceed 0,25 F_r for double row full complement cylindrical roller bearings and 0,5 F_r for other designs.

The axial load carrying capacity is primarily determined by the ability of the sliding surfaces of the roller end / flange contact to support loads. Factors having the greatest effect on this ability are the lubricant, operating temperature and the ability of the bearing to dissipate heat.

The formulae below are valid for normal operating conditions, i.e.:

- $\Delta T \approx 60 \text{ }^\circ\text{C}$ between the bearing operating and ambient temperature
- specific heat loss $\approx 0,5 \text{ mW/mm}^2$
- viscosity ratio $\kappa \geq 2$
- misalignment ≤ 1 minute of arc

For misalignment > 1 minute of arc, contact the SKF application engineering service.

<p>Surface of outside and bore diameter $\pi B (D + d) \leq 50\,000 \text{ mm}^2$</p> $F_{ap} = \frac{k_1 C_0 10^4}{n (d + D)} - k_2 F_r$	<p>To avoid any risk of flange fracture, the maximal constantly acting axial load is limited:</p> <p>Bearings in the 2.. series $\rightarrow F_{ap \text{ max}} \leq 0,0045 D^{1,5}$ Bearings in other series $\rightarrow F_{ap \text{ max}} \leq 0,0023 D^{1,7}$</p>
<p>Surface of outside and bore diameter $\pi B (D + d) > 50\,000 \text{ mm}^2$</p> $F_{ap} = \frac{7,5 k_1 C_0^{2/3} 10^4}{n (d + D)} - k_2 F_r$	
<p>Circulating oil applications</p> $F_{ap \text{ oil}} = F_{ap} + \frac{1,5 \times 10^4 k_1 \Delta T_s V_s}{n (d + D)}$	<p>High-capacity bearings $\rightarrow F_{ap \text{ max}} \leq 0,0035 D^{1,7}$</p>

For brief periods, provided it does not increase the bearing operating temperature $> 5 \text{ }^\circ\text{C}$ temporarily:

$$F_{ap \text{ brief}} \leq 2 F_{ap} \quad \text{where } F_{ap} = F_{ap}, F_{ap \text{ oil}} \text{ or } F_{ap \text{ max}}$$

Depending on the bearing size, load and speed, this “brief period” covers only several seconds or can last a few minutes. As rule of thumb it can be assumed that a “brief period” is the time it takes for the bearing to make 1 000 revolutions.

Occasional shock loads:

$$F_{ap \text{ shock}} \leq 3 F_{ap} \quad \text{where } F_{ap} = F_{ap}, F_{ap \text{ oil}} \text{ or } F_{ap \text{ max}}$$

Symbols	
B	= bearing width [mm]
C_0	= basic static load rating [kN] (→ product tables)
d	= bearing bore diameter [mm]
D	= bearing outside diameter [mm]
ΔT_S	= temperature difference between incoming and outgoing oil flow [°C]
F_a	= axial load [kN]
F_{ap}	= permissible axial load [kN]
$F_{ap\text{ brief}}$	= maximal axial load for brief periods [kN]
$F_{ap\text{ max}}$	= maximal constantly acting axial load [kN]
$F_{ap\text{ oil}}$	= maximum permissible axial load in circulating oil applications [kN]
$F_{ap\text{ shock}}$	= maximal occasional axial shock load [kN]
F_r	= radial load [kN]
k_1, k_2	= lubrication factors (→ table 8, page 598)
n	= rotational speed [r/min]
\dot{V}_S	= amount of oil flow [l/min]

5 Cylindrical roller bearings

Table 8

Bearing types	Lubrication factors			
	Oil lubrication		Grease lubrication	
	k_1	k_2	k_1	k_2
Single row cylindrical roller bearings and high-capacity cylindrical roller bearings	1,5	0,15	1	0,1
Single row full complement cylindrical roller bearings	1	0,3	0,5	0,15
Double row full complement cylindrical roller bearings	0,35	0,1	0,2	0,06

Flange support

When cylindrical roller bearings are subjected to heavy axial loads, axial run-out and the size of the abutment surfaces of adjacent components are particularly important for running accuracy and even load distribution on the flange.

The inner ring flange should only be supported up to half of its height (→ fig. 19) so that it is not subjected to damaging alternating stresses that can result, for example from shaft deflection.

For single row cylindrical roller bearings and high-capacity cylindrical roller bearings, the recommended shaft abutment diameter can be obtained using

$$d_{as} = 0,5 (d_1 + F)$$

where

d_{as} = shaft abutment diameter for axially loaded bearings [mm]

d_1 = inner ring flange diameter [mm]

F = inner ring raceway diameter [mm]

For full complement cylindrical roller bearings the recommended shaft abutment diameter d_{as} is listed in the product tables.

Fig. 19

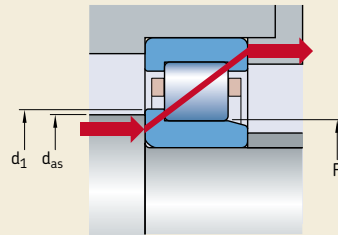

Temperature limits

The permissible operating temperature for cylindrical roller bearings can be limited by:

- the dimensional stability of the bearing rings and rollers
- the cage
- the seals
- the lubricant

When temperatures outside the permissible range are expected, contact the SKF application engineering service.

Bearing rings and rollers

SKF cylindrical roller bearings undergo a special heat treatment. The bearing rings and rollers are heat stabilized up to at least 150 °C (300 °F).

Cages

Steel, brass or PEEK cages can be used at the same operating temperatures as the bearing rings and rollers. For temperature limits of cages made of other polymer materials, refer to *Cage materials* (→ **page 152**).

Seals

The permissible operating temperature for PUR seals is –20 to +80 °C (–5 to 175 °F).

Lubricants

Temperature limits for the greases used in sealed double row full complement cylindrical roller bearings are provided in **table 1** (→ **page 580**). Temperature limits for other SKF greases are provided under *Lubrication* (→ **page 239**).

When using lubricants not supplied by SKF, the temperature limits should be evaluated according to the SKF traffic light concept (→ **page 244**).

Permissible speed

The permissible speed can be estimated using the speed ratings listed in the product tables and applying the information provided under *Speeds* (→ **page 117**). If no reference speed is listed in the product tables, the limiting speed is the permissible speed.

SKF recommends oil lubrication for bearings with a ring centred cage. When these bearings are grease lubricated (→ *Lubrication, Cylindrical roller bearings*, **page 254**) the speed factor is limited:

- for bearings with an MA, MB, MH, ML, MP, JA or JB cage
→ $A \leq 250\,000 \text{ mm/min}$
- for bearings with a PA or PHA cage
→ $A \leq 450\,000 \text{ mm/min}$

where

$$A = n d_m [\text{mm/min}]$$

$$d_m = \text{bearing mean diameter [mm]} \\ = 0,5 (d + D)$$

$$n = \text{rotational speed [r/min]}$$

For applications exceeding these values, contact the SKF application engineering service.

For single row bearings with a standard cage, the values for the limiting speed are listed in the product tables. Conversion factors to estimate the limiting speed for bearings with an alternative standard cage are listed in **table 9**.

Table 9

Conversion factors for limiting speeds of single row cylindrical roller bearings

Bearing with standard cage	alternative standard cage		ML
	P, PH, J, M, MR	PA, PHA, MA, MB	
P, PH, J, M, MR	1	1,3	1,5
PA, PHA, MA, MB	0,75	1	1,2
ML	0,65	0,85	1

Mounting

Interchangeable components

The separable components of same-size SKF cylindrical roller bearings are fully interchangeable, if the bearings are in the same internal clearance class.

High-capacity cylindrical roller bearings

Due to the design and position of the cage of high-capacity cylindrical roller bearings in the NCF .. ECJB and NJF .. ECJA series, the cage cannot prevent the rollers from falling out when the inner and outer rings of the bearing are separated. SKF recommends mounting these high-capacity cylindrical roller bearings as a complete bearing, like full complement cylindrical roller bearings.

If it is necessary to mount the inner and outer rings separately use a mounting sleeve or a retaining strap to keep the rollers in place (→ fig. 20).

Single row full complement cylindrical roller bearings, NJG design

NJG design bearings are separable. The outer ring together with the roller complement can be mounted independently from the inner ring without special precautions to prevent the rollers from falling out. The bearings have a self-retaining roller complement.

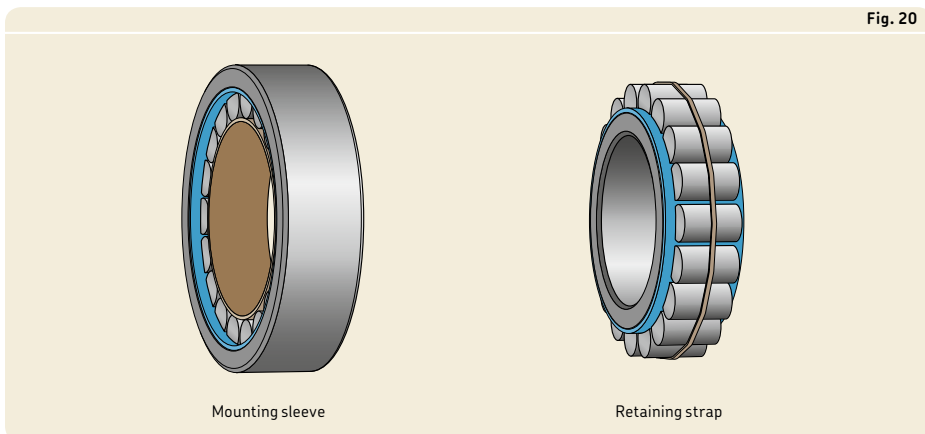

Designation system

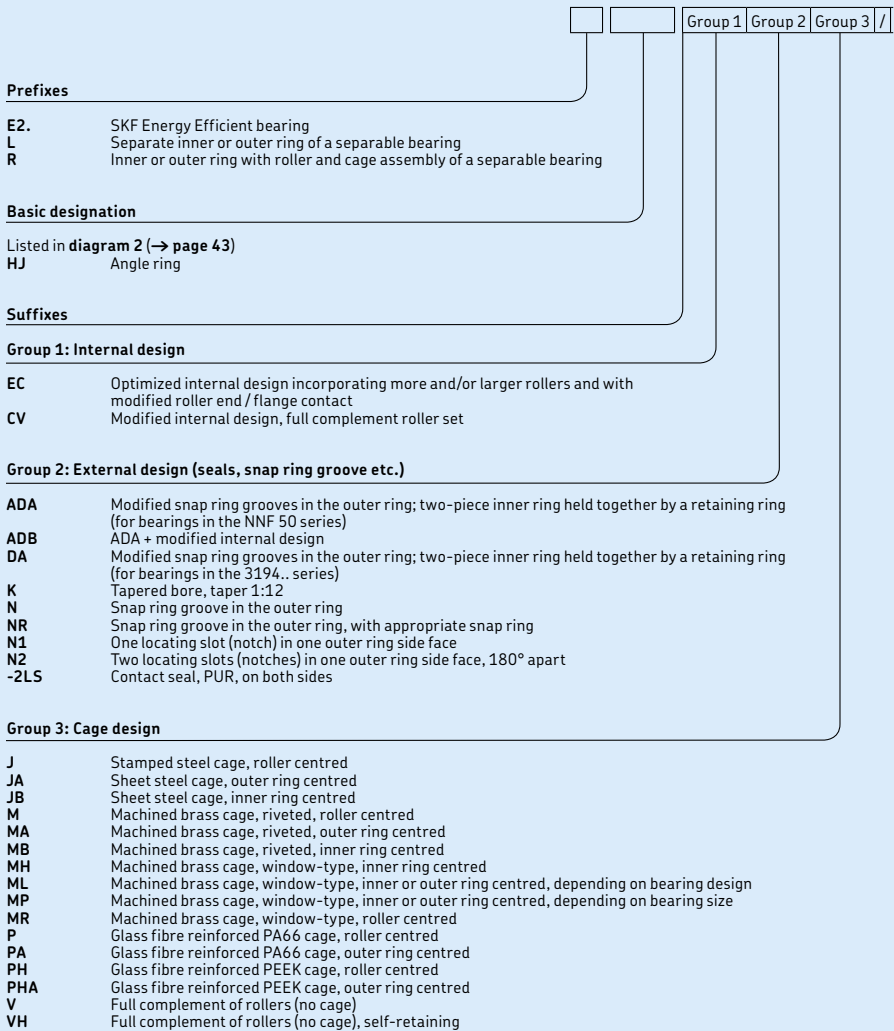

Group 4					
4.1	4.2	4.3	4.4	4.5	4.6

Group 4.6: Other variants

- PEX** SKF Explorer bearing, used only when same-sized conventional and SKF Explorer bearings are available
- VA301** Bearing for railway vehicle traction motors
- VA305** VA301 + special inspection routines
- VA350** Bearing for railway axleboxes
- VA380** Bearing for railway axleboxes in accordance with EN 12080, class 1
- VA3091** VA301 + external surfaces of the outer ring are coated with aluminium oxide
- VC025** Bearing with special wear-resistant raceways for applications in heavily contaminated environments
- VQ015** Inner ring with crowned raceway for increased permissible misalignment

Group 4.5: Lubrication

Group 4.4: Stabilization

- S1** Bearing rings heat stabilized for operating temperatures $\leq 200\text{ }^{\circ}\text{C}$ ($390\text{ }^{\circ}\text{F}$)
- S2** Bearing rings heat stabilized for operating temperatures $\leq 250\text{ }^{\circ}\text{C}$ ($480\text{ }^{\circ}\text{F}$)

Group 4.3: Bearing sets, matched bearings

- DR** Two bearings matched to one set
- TR** Three bearings matched to one set
- QR** Four bearings matched to one set

Group 4.2: Accuracy, clearance, preload, quiet running

- CN** Normal radial internal clearance; only used together with an additional letter that identifies a reduced or displaced clearance range
- H** Reduced clearance range corresponding to the upper half of the actual clearance range
- L** Reduced clearance range corresponding to the lower half of the actual clearance range
- M** Reduced clearance range corresponding to the middle half of the actual clearance range
- The above letters are also used together with the clearance classes C2, C3, C4 and C5, e.g. C2H
- C2** Radial internal clearance smaller than Normal
- C3** Radial internal clearance greater than Normal
- C4** Radial internal clearance greater than C3
- C5** Radial internal clearance greater than C4

Group 4.1: Materials, heat treatment

- HA1** Case-hardened inner and outer rings
- HA3** Case-hardened inner ring
- HB1** Bainite-hardened inner and outer rings
- HN1** Inner and outer rings with special surface heat treatment
- L4B** Bearing rings and rollers black oxidized
- L5B** Rollers black oxidized
- L7B** Inner ring and rollers black oxidized

5.1 Single row cylindrical roller bearings d 15 – 25 mm

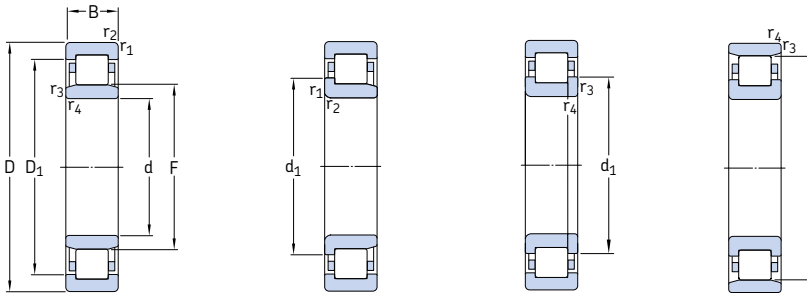

NU

NJ

NUP

N

Principal dimensions			Basic load ratings		Fatigue load limit	Speed ratings		Mass	Designations	Alternative standard cage ¹⁾	
d	D	B	dynamic C	static C ₀	P _u	Reference speed	Limiting speed		Bearing with standard cage		
mm			kN		kN	r/min		kg	–		
15	35	11	12,5	10,2	1,22	22 000	26 000	0,047	NU 202 ECP	PHA	
	35	11	12,5	10,2	1,22	22 000	26 000	0,048	NJ 202 ECP	PHA	
17	40	12	17,2	14,3	1,73	19 000	22 000	0,068	NU 203 ECP	PHA	
	40	12	17,2	14,3	1,73	19 000	22 000	0,07	NJ 203 ECP	PHA	
	40	12	17,2	14,3	1,73	19 000	22 000	0,072	NUP 203 ECP	PHA	
	40	12	17,2	14,3	1,73	19 000	22 000	0,066	N 203 ECP	PH	
	40	16	23,8	21,6	2,65	19 000	22 000	0,087	NU 2203 ECP	–	
	40	16	23,8	21,6	2,65	19 000	22 000	0,093	NJ 2203 ECP	–	
	40	16	23,8	21,6	2,65	19 000	22 000	0,097	NUP 2203 ECP	–	
	47	14	24,6	20,4	2,55	15 000	20 000	0,12	NU 303 ECP	–	
	47	14	24,6	20,4	2,55	15 000	20 000	0,12	NJ 303 ECP	–	
	47	14	24,6	20,4	2,55	15 000	20 000	0,12	N 303 ECP	–	
	20	47	14	25,1	22	2,75	16 000	19 000	0,11	NU 204 ECP	ML,PHA
		47	14	25,1	22	2,75	16 000	19 000	0,11	NJ 204 ECP	ML,PHA
47		14	25,1	22	2,75	16 000	19 000	0,12	NUP 204 ECP	ML,PHA	
47		14	25,1	22	2,75	16 000	19 000	0,11	N 204 ECP	–	
47		18	29,7	27,5	3,45	16 000	19 000	0,14	NU 2204 ECP	–	
47		18	29,7	27,5	3,45	16 000	19 000	0,14	NJ 2204 ECP	–	
52		15	35,5	26	3,25	15 000	18 000	0,15	* NU 304 ECP	–	
52		15	35,5	26	3,25	15 000	18 000	0,15	* NJ 304 ECP	–	
52		15	35,5	26	3,25	15 000	18 000	0,16	* NUP 304 ECP	–	
52		15	35,5	26	3,25	15 000	18 000	0,15	* N 304 ECP	–	
52		21	47,5	38	4,8	15 000	18 000	0,21	* NU 2304 ECP	–	
52		21	47,5	38	4,8	15 000	18 000	0,22	* NJ 2304 ECP	–	
52		21	47,5	38	4,8	15 000	18 000	0,22	* NUP 2304 ECP	–	
25		47	12	14,2	13,2	1,4	18 000	18 000	0,083	NU 1005	–
		52	15	28,6	27	3,35	14 000	16 000	0,13	NU 205 ECP	J, ML,PHA
	52	15	28,6	27	3,35	14 000	16 000	0,14	NJ 205 ECP	J, ML,PHA	
	52	15	28,6	27	3,35	14 000	16 000	0,14	NUP 205 ECP	J, ML,PHA	
	52	15	28,6	27	3,35	14 000	16 000	0,13	N 205 ECP	–	

¹⁾ When ordering bearings with an alternative standard cage the suffix of the standard cage has to be replaced by the suffix of the alternative cage. For example NU .. ECP becomes NU .. ECML (for permissible speed → page 600).

* SKF Explorer bearing

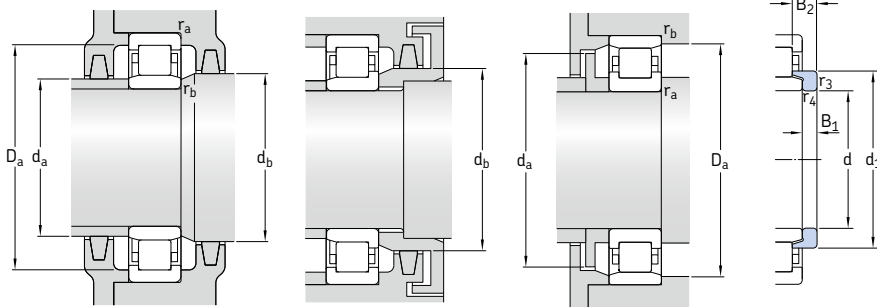

Angle ring

Dimensions							Abutment and fillet dimensions						Calculation factor k_r	Angle ring Designation	Mass	Dimensions	
d	d ₁	D ₁	F, E	r _{1,2}	r _{3,4}	s ¹⁾	d _a min.	d _a max.	d _b , D _a min.	D _a max.	r _a max.	r _b max.				B ₁	B ₂
mm							mm						-	-	kg	mm	
15	-	27,9	19,3	0,6	0,3	1	17,4	18,4	21	31,3	0,6	0,3	0,15	-			
	21,9	27,9	19,3	0,6	0,3	1	18,2	18,4	23	31,3	0,6	0,3	0,15	-			
17	-	32,4	22,1	0,6	0,3	1	19,9	21,1	24	36	0,6	0,3	0,15	-			
	25	32,4	22,1	0,6	0,3	1	20,7	21,1	27	36	0,6	0,3	0,15	-			
	25	32,4	22,1	0,6	0,3	-	20,7	-	27	36	0,6	0,3	0,15	-			
	25	-	35,1	0,6	0,3	1	20,7	33	37	37,1	0,6	0,3	0,12	-			
	-	32,4	22,1	0,6	0,3	1,5	19,9	21,1	24	36	0,6	0,3	0,2	-			
	25	32,4	22,1	0,6	0,3	1,5	20,7	21,1	27	36	0,6	0,3	0,2	-			
20	-	37	24,2	1	0,6	1	21,1	23,1	26	41,7	1	0,6	0,15	-			
	27,7	37	24,2	1	0,6	1	22,1	23,1	29	41,7	1	0,6	0,15	-			
	27,7	-	40,2	1	0,6	1	22,1	38	42	42,7	1	0,6	0,12	-			
25	-	38,8	26,5	1	0,6	1	24	25,4	28	41,7	1	0,6	0,15	-			
	29,7	38,8	26,5	1	0,6	1	25	25,4	31	41,7	1	0,6	0,15	-			
	29,7	38,8	26,5	1	0,6	-	25	-	31	41,7	1	0,6	0,15	-			
	29,7	-	41,5	1	0,6	1	25	40	43	43,5	1	0,6	0,12	-			
	-	38,8	26,5	1	0,6	2	24	25,4	28	41,7	1	0,6	0,2	-			
	29,7	38,8	26,5	1	0,6	2	25	25,4	31	41,7	1	0,6	0,2	-			
	31,2	42,4	27,5	1,1	0,6	0,9	24,1	26,2	29	45,4	1	0,6	0,15	HJ 304 EC	0,017	4	6,5
	31,2	42,4	27,5	1,1	0,6	0,9	26,1	26,2	33	45,4	1	0,6	0,15	HJ 304 EC	0,017	4	6,5
	31,2	42,4	27,5	1,1	0,6	-	26,1	-	33	45,4	1	0,6	0,15	-			
	31,2	-	45,5	1,1	0,6	0,9	26,1	44	47	48	1	0,6	0,12	-			
25	-	42,4	27,5	1,1	0,6	1,9	24,1	26,2	29	45,4	1	0,6	0,25	-			
	31,2	42,4	27,5	1,1	0,6	1,9	26,1	26,2	33	45,4	1	0,6	0,25	-			
	31,2	42,4	27,5	1,1	0,6	-	26,1	-	33	45,4	1	0,6	0,25	-			
	-	38,8	30,5	0,6	0,3	2	27,1	29,5	32	43,1	0,6	0,3	0,1	-			
25	34,7	43,8	31,5	1	0,6	1,3	28,9	30,4	33	46,4	1	0,6	0,15	HJ 205 EC	0,015	3	6
	34,7	43,8	31,5	1	0,6	1,3	29,9	30,4	36	46,4	1	0,6	0,15	HJ 205 EC	0,015	3	6
	34,7	43,8	31,5	1	0,6	-	29,9	-	36	46,4	1	0,6	0,15	-			
	34,7	-	46,5	1	0,6	1,3	29,9	45	48	48,5	1	0,6	0,12	-			

¹⁾ Permissible axial displacement from the normal position of one bearing ring relative to the other.

5.1 Single row cylindrical roller bearings d 25 – 30 mm

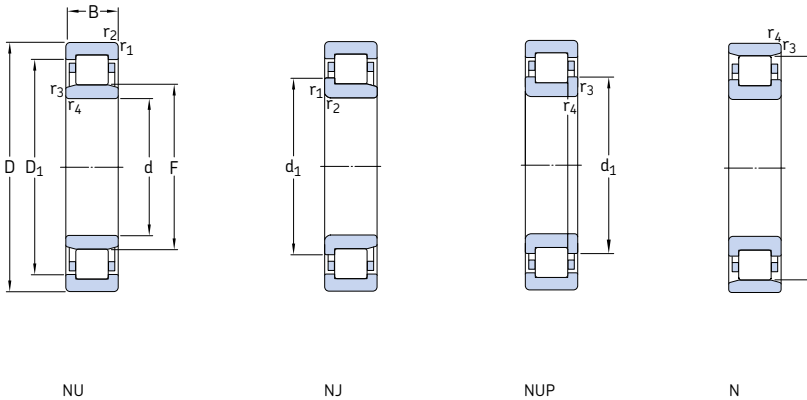

Principal dimensions	Basic load ratings		Fatigue load limit P_u	Speed ratings		Mass	Designations Bearing with standard cage	Alternative standard cage ¹⁾		
	dynamic C	static C_0		Reference speed	Limiting speed					
d	D	B								
mm			kN	kN	r/min	kg	-			
25 cont.	52	18	34,1	34	4,25	14 000	16 000	0,16	NU 2205 ECP	ML
	52	18	34,1	34	4,25	14 000	16 000	0,17	NJ 2205 ECP	ML
	52	18	34,1	34	4,25	14 000	16 000	0,17	NUP 2205 ECP	ML
	62	17	46,5	36,5	4,55	12 000	15 000	0,23	* NU 305 ECP	J, ML
	62	17	46,5	36,5	4,55	12 000	15 000	0,24	* NJ 305 ECP	J, ML
	62	17	46,5	36,5	4,55	12 000	15 000	0,25	* NUP 305 ECP	J, ML
	62	17	46,5	36,5	4,55	12 000	15 000	0,24	* N 305 ECP	-
	62	24	64	55	6,95	12 000	15 000	0,34	* NU 2305 ECP	J, ML
	62	24	64	55	6,95	12 000	15 000	0,35	* NJ 2305 ECP	J, ML
	62	24	64	55	6,95	12 000	15 000	0,36	* NUP 2305 ECP	J, ML
30	55	13	17,9	17,3	1,86	15 000	15 000	0,12	NU 1006	-
	62	16	44	36,5	4,5	13 000	14 000	0,2	* NU 206 ECP	J, ML, PH
	62	16	44	36,5	4,5	13 000	14 000	0,21	* NJ 206 ECP	J, ML, PH
	62	16	44	36,5	4,5	13 000	14 000	0,21	* NUP 206 ECP	J, ML, PH
	62	16	44	36,5	4,5	13 000	14 000	0,2	* N 206 ECP	-
	62	20	55	49	6,1	13 000	14 000	0,26	* NU 2206 ECP	J, ML, PH
	62	20	55	49	6,1	13 000	14 000	0,26	* NJ 2206 ECP	J, ML, PH
	62	20	55	49	6,1	13 000	14 000	0,27	* NUP 2206 ECP	J, ML, PH
	72	19	58,5	48	6,2	11 000	12 000	0,36	* NU 306 ECP	J, M, ML
	72	19	58,5	48	6,2	11 000	12 000	0,37	* NJ 306 ECP	J, M, ML
	72	19	58,5	48	6,2	11 000	12 000	0,38	* NUP 306 ECP	J, M, ML
	72	19	58,5	48	6,2	11 000	12 000	0,36	* N 306 ECP	-
	72	27	83	75	9,65	11 000	12 000	0,53	* NU 2306 ECP	ML
	72	27	83	75	9,65	11 000	12 000	0,54	* NJ 2306 ECP	ML
	72	27	83	75	9,65	11 000	12 000	0,55	* NUP 2306 ECP	ML
	90	23	60,5	53	6,8	9 000	11 000	0,75	NU 406	MA
90	23	60,5	53	6,8	9 000	11 000	0,79	NJ 406	MA	

¹⁾ When ordering bearings with an alternative standard cage the suffix of the standard cage has to be replaced by the suffix of the alternative cage. For example NU .. ECP becomes NU .. ECML (for permissible speed → page 600).

* SKF Explorer bearing

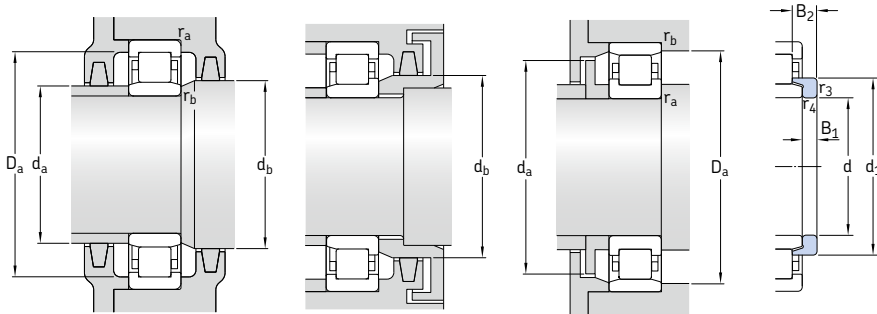

Angle ring

Dimensions				Abutment and fillet dimensions							Calculation factor		Angle ring Designation	Mass	Dimensions			
d	d ₁	D ₁	F, E	r _{1,2}	r _{3,4}	s ¹⁾	d _a min.	d _a max.	d _b , D _a min.	D _a max.	r _a max.	r _b max.	k _r		kg	B ₁	B ₂	
mm																		
25 cont.	34,7	43,8	31,5	1	0,6	1,8	28,9	30,4	33	46,4	1	0,6	0,2	HJ 2205 EC	0,014	3	6,5	
	34,7	43,8	31,5	1	0,6	1,8	29,9	30,4	36	46,4	1	0,6	0,2	HJ 2205 EC	0,014	3	6,5	
	34,7	43,8	31,5	1	0,6	-	29,9	-	36	46,4	1	0,6	0,2	-	-	-	-	
	38,1	50,7	34	1,1	1,1	1,3	31	32,5	36	54,9	1	1	0,15	HJ 305 EC	0,025	4	7	
	38,1	50,7	34	1,1	1,1	1,3	31	32,5	40	54,9	1	1	0,15	HJ 305 EC	0,025	4	7	
	38,1	50,7	34	1,1	1,1	-	31	-	40	54,9	1	1	0,15	-	-	-	-	
	38,1	-	54	1,1	1,1	1,3	31	52	56	56,4	1	1	0,12	-	-	-	-	
	38,1	50,7	34	1,1	1,1	2,3	31	32,5	36	54,9	1	1	0,25	HJ 2305 EC	0,023	4	8	
	38,1	50,7	34	1,1	1,1	2,3	31	32,5	40	54,9	1	1	0,25	HJ 2305 EC	0,023	4	8	
	38,1	50,7	34	1,1	1,1	-	31	-	40	54,9	1	1	0,25	-	-	-	-	
	30	-	45,6	36,5	1	0,6	2,1	32,9	35,4	38	49,8	1	0,6	0,1	-	-	-	-
		41,2	52,5	37,5	1	0,6	1,3	34,3	36,1	39	55,9	1	0,6	0,15	HJ 206 EC	0,025	4	7
41,2		52,5	37,5	1	0,6	1,3	35,3	36,1	43	55,9	1	0,6	0,15	HJ 206 EC	0,025	4	7	
41,2		52,5	37,5	1	0,6	-	35,3	-	43	55,9	1	0,6	0,15	-	-	-	-	
41,2		-	55,5	1	0,6	1,3	35,3	54	57	58,1	1	0,6	0,12	-	-	-	-	
-		52,5	37,5	1	0,6	1,8	34,3	36,1	39	55,9	1	0,6	0,2	-	-	-	-	
41,2		52,5	37,5	1	0,6	1,8	35,3	36,1	43	55,9	1	0,6	0,2	-	-	-	-	
41,2		52,5	37,5	1	0,6	-	35,3	-	43	55,9	1	0,6	0,2	-	-	-	-	
45		58,9	40,5	1,1	1,1	1,4	37	39	43	65,1	1	1	0,15	HJ 306 EC	0,042	5	8,5	
45		58,9	40,5	1,1	1,1	1,4	37	39	47	65,1	1	1	0,15	HJ 306 EC	0,042	5	8,5	
45		58,9	40,5	1,1	1,1	-	37	-	47	65,1	1	1	0,15	-	-	-	-	
45		-	62,5	1,1	1,1	1,4	37	61	64	65,5	1	1	0,12	-	-	-	-	
-		58,9	40,5	1,1	1,1	2,4	37	39	43	65,1	1	1	0,25	-	-	-	-	
45		58,9	40,5	1,1	1,1	2,4	37	39	47	65,1	1	1	0,25	-	-	-	-	
45		58,9	40,5	1,1	1,1	-	37	-	47	65,1	1	1	0,25	-	-	-	-	
50,5		66,6	45	1,5	1,5	1,6	41	43	47	81	1,5	1,5	0,15	HJ 406	0,08	7	11,5	
50,5		66,6	45	1,5	1,5	1,6	41	43	53	81	1,5	1,5	0,15	HJ 406	0,08	7	11,5	

¹⁾ Permissible axial displacement from the normal position of one bearing ring relative to the other.

5.1 Single row cylindrical roller bearings d 35 – 40 mm

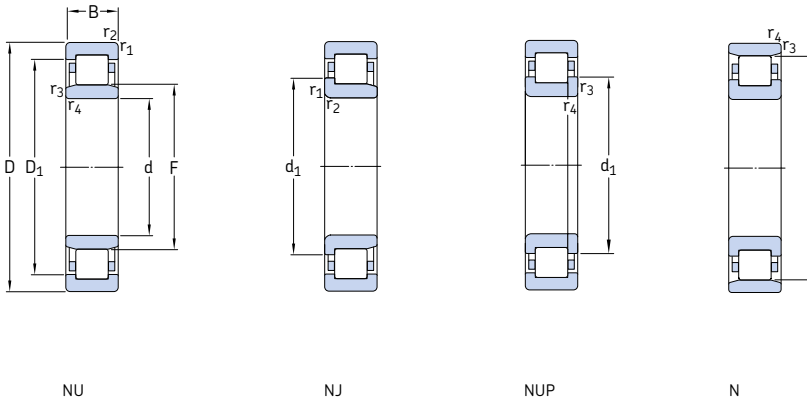

Principal dimensions			Basic load ratings		Fatigue load limit P_u	Speed ratings		Mass	Designations Bearing with standard cage	Alternative standard cage ¹⁾
d	D	B	dynamic C	static C_0		Reference speed	Limiting speed			
mm			kN		kN	r/min		kg	–	
35	62	14	35,8	38	4,55	13 000	13 000	0,16	NU 1007 ECP	PH
	72	17	56	48	6,1	11 000	12 000	0,29	* NU 207 ECP	J, M, ML, PH
	72	17	56	48	6,1	11 000	12 000	0,3	* NJ 207 ECP	J, M, ML, PH
	72	17	56	48	6,1	11 000	12 000	0,31	* NUP 207 ECP	J, M, ML, PH
	72	17	56	48	6,1	11 000	12 000	0,3	* N 207 ECP	–
	72	23	69,5	63	8,15	11 000	12 000	0,4	* NU 2207 ECP	J, ML, PH
	72	23	69,5	63	8,15	11 000	12 000	0,41	* NJ 2207 ECP	J, ML, PH
	72	23	69,5	63	8,15	11 000	12 000	0,42	* NUP 2207 ECP	J, ML, PH
	80	21	75	63	8,15	9 500	11 000	0,47	* NU 307 ECP	J, M, ML
	80	21	75	63	8,15	9 500	11 000	0,49	* NJ 307 ECP	J, M, ML
	80	21	75	63	8,15	9 500	11 000	0,5	* NUP 307 ECP	J, M, ML
	80	21	75	63	8,15	9 500	11 000	0,48	* N 307 ECP	–
	80	31	106	98	12,7	9 500	11 000	0,72	* NU 2307 ECP	PH
	80	31	106	98	12,7	9 500	11 000	0,73	* NJ 2307 ECP	PH
	80	31	106	98	12,7	9 500	11 000	0,76	* NUP 2307 ECP	PH
	100	25	76,5	69,5	9	8 000	9 500	1	NU 407	–
100	25	76,5	69,5	9	8 000	9 500	1	NJ 407	–	
40	68	15	25,1	26	3	12 000	18 000	0,23	NU 1008 ML	–
	80	18	62	53	6,7	9 500	11 000	0,37	* NU 208 ECP	J, M, ML, PH
	80	18	62	53	6,7	9 500	11 000	0,38	* NJ 208 ECP	J, M, ML, PH
	80	18	62	53	6,7	9 500	11 000	0,39	* NUP 208 ECP	J, M, ML, PH
	80	18	62	53	6,7	9 500	11 000	0,37	* N 208 ECP	PH
	80	23	81,5	75	9,65	9 500	11 000	0,49	* NU 2208 ECP	J, ML, PH
	80	23	81,5	75	9,65	9 500	11 000	0,5	* NJ 2208 ECP	J, ML, PH
	80	23	81,5	75	9,65	9 500	11 000	0,51	* NUP 2208 ECP	J, ML, PH
	90	23	93	78	10,2	8 000	9 500	0,65	* NU 308 ECP	J, M, ML, PH
	90	23	93	78	10,2	8 000	9 500	0,67	* NJ 308 ECP	J, M, ML, PH
	90	23	93	78	10,2	8 000	9 500	0,68	* NUP 308 ECP	J, M, ML, PH
	90	23	93	78	10,2	8 000	9 500	0,65	* N 308 ECP	M

¹⁾ When ordering bearings with an alternative standard cage the suffix of the standard cage has to be replaced by the suffix of the alternative cage. For example NU .. ECP becomes NU .. ECML (for permissible speed → page 600).

* SKF Explorer bearing

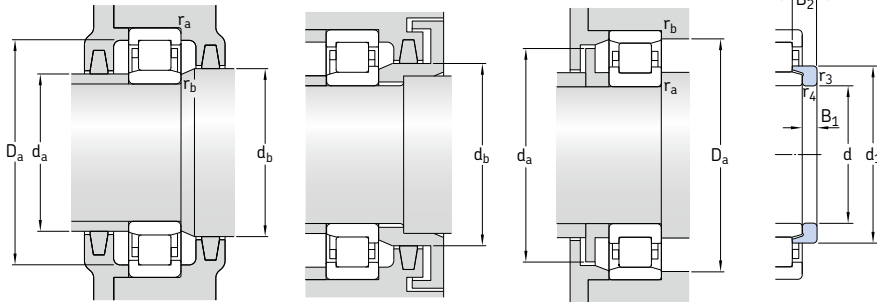

Angle ring

Dimensions							Abutment and fillet dimensions					Calculation factor k_r	Angle ring Designation	Mass	Dimensions		
d	d ₁	D ₁	F, E	r _{1,2} min.	r _{3,4} min.	s ¹⁾	d _a min.	d _a max.	d _b , D _a min.	D _a max.	r _a max.				r _b max.	B ₁	B ₂
mm																	
35	-	54,5	42	1	0,6	1	38	41	44	56,5	1	0,6	0,1	-			
	48,1	60,7	44	1,1	0,6	1,3	39,8	42,2	46	65,1	1	0,6	0,15	HJ 207 EC	0,033	4	7
	48,1	60,7	44	1	0,6	1,3	41,8	42,2	50	65,1	1	0,6	0,15	HJ 207 EC	0,033	4	7
	48,1	60,7	44	1,1	0,6	-	41,8	-	50	65,1	1	0,6	0,15	-			
	48,1	-	64	1,1	0,6	1,3	41,8	62	66	67,2	1	0,6	0,12	-			
	-	60,7	44	1,1	0,6	2,8	39,8	42,2	46	65,1	1	0,6	0,2	-			
	48,1	60,7	44	1,1	0,6	2,8	41,8	42,2	50	65,1	1	0,6	0,2	-			
	48,1	60,7	44	1,1	0,6	-	41,8	-	50	65,1	1	0,6	0,2	-			
	51	66,3	46,2	1,5	1,1	1,2	42	44	48	72,2	1,5	1	0,15	HJ 307 EC	0,058	6	9,5
	51	66,3	46,2	1,5	1,1	1,2	43	44	53	72,2	1,5	1	0,15	HJ 307 EC	0,058	6	9,5
	51	66,3	46,2	1,5	1,1	-	43	-	53	72,2	1,5	1	0,15	-			
	51	-	70,2	1,5	1,1	1,2	43	68	72	73,4	1,5	1	0,12	-			
	-	66,3	46,2	1,5	1,1	2,7	42	44	48	72,2	1,5	1	0,25	-			
	51	66,3	46,2	1,5	1,1	2,7	43	44	53	72,2	1,5	1	0,25	-			
	51	66,3	46,2	1,5	1,1	-	43	-	53	72,2	1,5	1	0,25	-			
	-	76,1	53	1,5	1,5	1,7	48	51	55	90	1,5	1,5	0,15	-			
	59	76,1	53	1,5	1,5	1,7	48	51	61	90	1,5	1,5	0,15	-			
									0								
40	-	57,6	47	1	0,6	2,4	43	46	49	62,3	1	0,6	0,15	-			
	54	67,9	49,5	1,1	1,1	1,4	47	48	51	72,8	1	1	0,15	HJ 208 EC	0,047	5	8,5
	54	67,9	49,5	1,1	1,1	1,4	47	48	56	72,8	1	1	0,15	HJ 208 EC	0,047	5	8,5
	54	67,9	49,5	1,1	1,1	-	47	-	56	72,8	1	1	0,15	-			
	54	-	71,5	1,1	1,1	1,4	47	69	73	74,1	1	1	0,12	-			
	54	67,9	49,5	1,1	1,1	1,9	47	48	51	72,8	1	1	0,2	HJ 2208 EC	0,048	5	9
	54	67,9	49,5	1,1	1,1	1,9	47	48	56	72,8	1	1	0,2	HJ 2208 EC	0,048	5	9
	54	67,9	49,5	1,1	1,1	-	47	-	56	72,8	1	1	0,2	-			
	57,5	75,6	52	1,5	1,5	1,4	48	50	54	81,8	1,5	1,5	0,15	HJ 308 EC	0,084	7	11
	57,5	75,6	52	1,5	1,5	1,4	48	50	60	81,8	1,5	1,5	0,15	HJ 308 EC	0,084	7	11
	57,5	75,6	52	1,5	1,5	-	48	-	60	81,8	1,5	1,5	0,15	-			
	57,5	-	80	1,5	1,5	1,4	48	78	82	83,2	1,5	1,5	0,12	-			

¹⁾ Permissible axial displacement from the normal position of one bearing ring relative to the other.

5.1 Single row cylindrical roller bearings d 40 – 50 mm

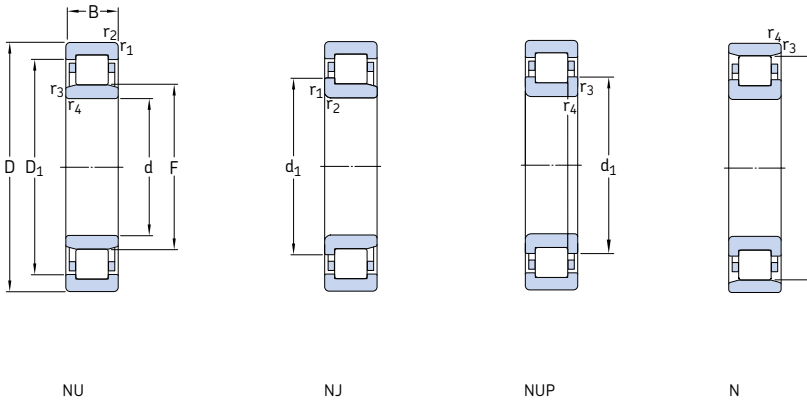

Principal dimensions			Basic load ratings		Fatigue load limit P_u	Speed ratings		Mass	Designations Bearing with standard cage	Alternative standard cage ¹⁾
d	D	B	dynamic C	static C_0		Reference speed	Limiting speed			
mm			kN		kN	r/min		kg	–	
40 cont.	90	33	129	120	15,3	8 000	9 500	0,94	* NU 2308 ECP	J, M, ML, PH
	90	33	129	120	15,3	8 000	9 500	0,95	* NJ 2308 ECP	J, M, ML, PH
	90	33	129	120	15,3	8 000	9 500	0,98	* NUP 2308 ECP	J, M, ML, PH
	110	27	96,8	90	11,6	7 000	8 500	1,3	NU 408	MA
	110	27	96,8	90	11,6	7 000	8 500	1,3	NJ 408	MA
45	75	16	44,6	52	6,3	11 000	11 000	0,25	NU 1009 ECP	PH
	75	16	44,6	52	6,3	11 000	11 000	0,26	NJ 1009 ECP	PH
	85	19	69,5	64	8,15	9 000	9 500	0,43	* NU 209 ECP	J, M, ML
	85	19	69,5	64	8,15	9 000	9 500	0,44	* NJ 209 ECP	J, M, ML
	85	19	69,5	64	8,15	9 000	9 500	0,45	* NUP 209 ECP	J, M, ML
	85	19	69,5	64	8,15	9 000	9 500	0,43	* N 209 ECP	M
	85	23	85	81,5	10,6	9 000	9 500	0,52	* NU 2209 ECP	J
	85	23	85	81,5	10,6	9 000	9 500	0,54	* NJ 2209 ECP	J
	85	23	85	81,5	10,6	9 000	9 500	0,55	* NUP 2209 ECP	J
	100	25	112	100	12,9	7 500	8 500	0,9	* NU 309 ECP	J, M, ML, PH
	100	25	112	100	12,9	7 500	8 500	0,89	* NJ 309 ECP	J, M, ML, PH
	100	25	112	100	12,9	7 500	8 500	0,93	* NUP 309 ECP	J, M, ML, PH
100	25	112	100	12,9	7 500	8 500	0,88	* N 309 ECP	–	
100	36	160	153	20	7 500	8 500	1,3	* NU 2309 ECP	ML	
100	36	160	153	20	7 500	8 500	1,35	* NJ 2309 ECP	ML	
100	36	160	153	20	7 500	8 500	1,35	* NUP 2309 ECP	ML	
120	29	106	102	13,4	6 700	7 500	1,65	NU 409	–	
120	29	106	102	13,4	6 700	7 500	1,65	NJ 409	–	
50	80	16	46,8	56	6,7	9 500	9 500	0,27	NU 1010 ECP	–
	90	20	73,5	69,5	8,8	8 500	9 000	0,48	* NU 210 ECP	J, M, ML
	90	20	73,5	69,5	8,8	8 500	9 000	0,49	* NJ 210 ECP	J, M, ML
	90	20	73,5	69,5	8,8	8 500	9 000	0,51	* NUP 210 ECP	J, M, ML
	90	20	73,5	69,5	8,8	8 500	9 000	0,48	* N 210 ECP	M

¹⁾ When ordering bearings with an alternative standard cage the suffix of the standard cage has to be replaced by the suffix of the alternative cage. For example NU .. ECP becomes NU .. ECML (for permissible speed → page 600).

* SKF Explorer bearing

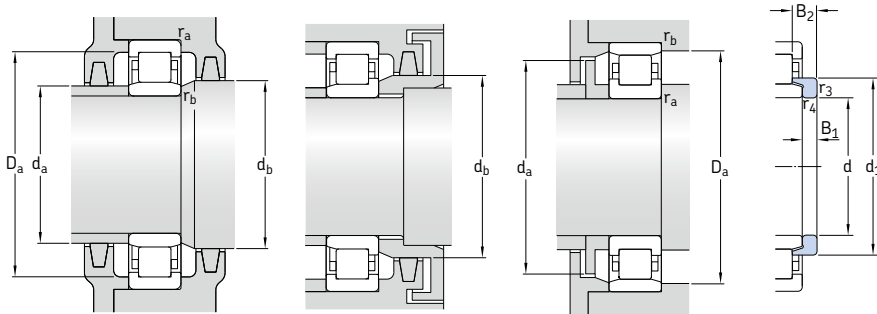

Angle ring

Dimensions							Abutment and fillet dimensions						Calculation factor		Angle ring Designation	Mass	Dimensions	
d	d ₁	D ₁	F, E	r _{1,2}	r _{3,4}	s ¹⁾	d _a min.	d _a max.	d _b , D _a min.	D _a max.	r _a max.	r _b max.	k _r		kg	B ₁	B ₂	
mm																		
40 cont.	-	75,6	52	1,5	1,5	2,9	48	50	54	81,8	1,5	1,5	0,25	-				
	57,5	75,6	52	1,5	1,5	2,9	48	50	60	81,8	1,5	1,5	0,25	-				
	57,5	75,6	52	1,5	1,5	-	48	-	60	81,8	1,5	1,5	0,25	-				
	-	84,2	58	2	2	2,5	52	56	60	99	2	2	0,15	-				
	64,8	84,2	58	2	2	2,5	52	56	67	99	2	2	0,15	-				
45	-	65,3	52,5	1	0,6	0,9	48,4	51	54	69,8	1	0,6	0,1	-				
	56	65,3	52,5	1	0,6	0,9	48,4	51	57,5	69,8	1	0,6	0,1	-				
	59	73	54,5	1,1	1,1	1,2	52	53	56	77,6	1	1	0,15	HJ 209 EC	0,052	5	8,5	
	59	73	54,5	1,1	1,1	1,2	52	53	61	77,6	1	1	0,15	HJ 209 EC	0,052	5	8,5	
	59	73	54,5	1,1	1,1	-	52	-	61	77,6	1	1	0,15	-				
	59	-	76,5	1,1	1,1	1,2	52	74	78	79,1	1	1	0,12	-				
	-	73	54,5	1,1	1,1	1,7	52	53	56	77,6	1	1	0,2	-				
	59	73	54,5	1,1	1,1	1,7	52	53	61	77,6	1	1	0,2	-				
	59	73	54,5	1,1	1,1	-	52	-	61	77,6	1	1	0,2	-				
	64,4	83,8	58,5	1,5	1,5	1,7	54	56	60	91,4	1,5	1,5	0,15	HJ 309 EC	0,11	7	11,5	
	64,4	83,8	58,5	1,5	1,5	1,7	54	56	67	91,4	1,5	1,5	0,15	HJ 309 EC	0,11	7	11,5	
	64,4	83,8	58,5	1,5	1,5	-	54	-	67	91,4	1,5	1,5	0,15	-				
64,4	-	88,5	1,5	1,5	1,7	54	86	91	92,3	1,5	1,5	0,12	-					
-	83,8	58,5	1,5	1,5	3,2	54	56	60	91,4	1,5	1,5	0,25	-					
64,4	83,8	58,5	1,5	1,5	3,2	54	56	67	91,4	1,5	1,5	0,25	-					
64,4	83,8	58,5	1,5	1,5	-	54	-	67	91,4	1,5	1,5	0,25	-					
71,8	92,2	64,5	2	2	2,5	58	62	66	108	2	2	0,15	HJ 409	0,18	8	13,5		
71,8	92,2	64,5	2	2	2,5	58	62	75	108	2	2	0,15	HJ 409	0,18	8	13,5		
50	-	70	57,5	1	0,6	1	53,4	56	59	74,6	1	0,6	0,1	-				
	64	78	59,5	1,1	1,1	1,5	57	57,5	61	82,4	1	1	0,15	HJ 210 EC	0,058	5	9	
	64	78	59,5	1,1	1,1	1,5	57	57,5	66	82,4	1	1	0,15	HJ 210 EC	0,058	5	9	
	64	78	59,5	1,1	1,1	-	57	-	66	82,4	1	1	0,15	-				
	64	-	81,5	1,1	1,1	1,5	57	79	83	84	1	1	0,12	-				

¹⁾ Permissible axial displacement from the normal position of one bearing ring relative to the other.

5.1 Single row cylindrical roller bearings d 50 – 55 mm

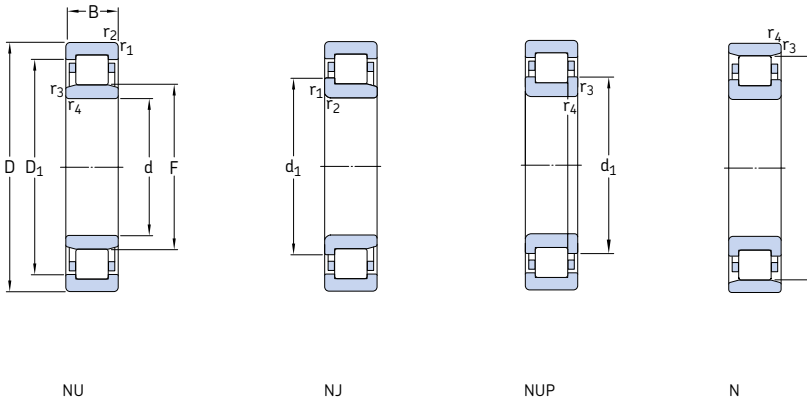

Principal dimensions			Basic load ratings		Fatigue load limit P_u	Speed ratings		Mass	Designations Bearing with standard cage	Alternative standard cage ¹⁾
d	D	B	dynamic C	static C_0		Reference speed	Limiting speed			
mm			kN		kN	r/min	kg	-		
50 cont.	90	23	90	88	11,4	8 500	9 000	0,56	* NU 2210 ECP	J, M, ML, PH
	90	23	90	88	11,4	8 500	9 000	0,57	* NJ 2210 ECP	J, M, ML, PH
	90	23	90	88	11,4	8 500	9 000	0,59	* NUP 2210 ECP	J, M, ML, PH
	110	27	127	112	15	6 700	8 000	1,15	* NU 310 ECP	J, M, ML, PH
	110	27	127	112	15	6 700	8 000	1,15	* NJ 310 ECP	J, M, ML, PH
	110	27	127	112	15	6 700	8 000	1,15	* NUP 310 ECP	J, M, ML, PH
	110	27	127	112	15	6 700	8 000	1,15	* N 310 ECP	-
	110	40	186	186	24,5	6 700	8 000	1,75	* NU 2310 ECP	J, ML, PH
	110	40	186	186	24,5	6 700	8 000	1,75	* NJ 2310 ECP	J, ML, PH
	110	40	186	186	24,5	6 700	8 000	1,75	* NUP 2310 ECP	J, ML, PH
	130	31	130	127	16,6	6 000	7 000	2	NU 410	-
	130	31	130	127	16,6	6 000	7 000	2,05	NJ 410	-
55	90	18	57,2	69,5	8,3	8 500	8 500	0,39	NU 1011 ECP	ML
	90	18	57,2	69,5	8,3	8 500	8 500	0,42	NJ 1011 ECP	ML
	100	21	96,5	95	12,2	7 500	8 000	0,66	* NU 211 ECP	J, M, ML
	100	21	96,5	95	12,2	7 500	8 000	0,67	* NJ 211 ECP	J, M, ML
	100	21	96,5	95	12,2	7 500	8 000	0,68	* NUP 211 ECP	J, M, ML
	100	21	96,5	95	12,2	7 500	8 000	0,65	* N 211 ECP	M
	100	25	114	118	15,3	7 500	8 000	0,79	* NU 2211 ECP	J, M, ML, PH
	100	25	114	118	15,3	7 500	8 000	0,81	* NJ 2211 ECP	J, M, ML, PH
	100	25	114	118	15,3	7 500	8 000	0,82	* NUP 2211 ECP	J, M, ML, PH
	120	29	156	143	18,6	6 000	7 000	1,45	* NU 311 ECP	J, M, ML
	120	29	156	143	18,6	6 000	7 000	1,5	* NJ 311 ECP	J, M, ML
	120	29	156	143	18,6	6 000	7 000	1,5	* NUP 311 ECP	J, M, ML
	120	29	156	143	18,6	6 000	7 000	1,45	* N 311 ECP	M
	120	43	232	232	30,5	6 000	7 000	2,2	* NU 2311 ECP	J, ML, PH
	120	43	232	232	30,5	6 000	7 000	2,25	* NJ 2311 ECP	J, ML, PH
	120	43	232	232	30,5	6 000	7 000	2,3	* NUP 2311 ECP	J, ML, PH

¹⁾ When ordering bearings with an alternative standard cage the suffix of the standard cage has to be replaced by the suffix of the alternative cage. For example NU .. ECP becomes NU .. ECML (for permissible speed → page 600).

* SKF Explorer bearing

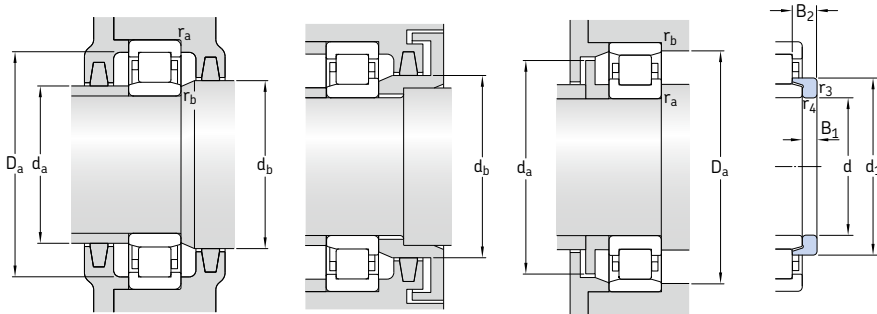

Angle ring

Dimensions							Abutment and fillet dimensions						Calculation factor k_r	Angle ring Designation	Mass	Dimensions	
d	d ₁	D ₁	F, E	r _{1,2} min.	r _{3,4} min.	s ¹⁾	d _a min.	d _a max.	d _b , D _a min.	D _a max.	r _a max.	r _b max.				B ₁	B ₂
mm							mm						-	-	kg	mm	
50 cont.	-	78	59,5	1,1	1,1	1,5	57	57,5	61	82,4	1	1	0,2	-	-	-	-
	64	78	59,5	1,1	1,1	1,5	57	57,5	66	82,4	1	1	0,2	-	-	-	-
	64	78	59,5	1,1	1,1	-	57	-	66	82,4	1	1	0,2	-	-	-	-
	71,2	92,1	65	2	2	1,9	60	63	67	99,6	2	2	0,15	HJ 310 EC	0,15	8	13
	71,2	92,1	65	2	2	1,9	60	63	73	99,6	2	2	0,15	HJ 310 EC	0,15	8	13
	71,2	92,1	65	2	2	-	60	-	73	99,6	2	2	0,15	-	-	-	-
	71,2	-	97	2	2	1,9	60	95	99	101	2	2	0,12	-	-	-	-
	-	92,1	65	2	2	3,4	60	63	67	99,6	2	2	0,25	-	-	-	-
	71,2	92,1	65	2	2	3,4	60	63	73	99,6	2	2	0,25	-	-	-	-
	71,2	92,1	65	2	2	-	60	-	73	99,6	2	2	0,25	-	-	-	-
	78,8	102	70,8	2,1	2,1	2,6	64	68	73	116	2	2	0,15	HJ 410	0,15	9	14,5
	78,8	102	70,8	2,1	2,1	2,6	64	68	81	116	2	2	0,15	HJ 410	0,15	9	14,5
55	-	79	64,5	1,1	1	0,5	59,7	63	66	83	1	1	0,1	-	-	-	-
	68	79	57,5	1,1	1	0,5	60	63	70	83	1	1	0,1	-	-	-	-
	70,8	86,3	66	1,5	1,1	1	62	64	68	91,4	1,5	1	0,15	HJ 211 EC	0,083	6	9,5
	70,8	86,3	66	1,5	1,1	1	63	64	73	91,4	1,5	1	0,15	HJ 211 EC	0,083	6	9,5
	70,8	86,3	66	1,5	1,1	-	63	-	73	91,4	1,5	1	0,15	-	-	-	-
	70,8	-	90	1,5	1,1	1	63	88	92	93	1,5	1	0,12	-	-	-	-
	70,8	86,3	66	1,5	1,1	1,5	62	64	68	91,4	1,5	1	0,2	HJ 2211 EC	0,085	6	10
	70,8	86,3	66	1,5	1,1	1,5	63	64	73	91,4	1,5	1	0,2	HJ 2211 EC	0,085	6	10
	70,8	86,3	66	1,5	1,1	-	63	-	73	91,4	1,5	1	0,2	-	-	-	-
	77,5	101	70,5	2	2	2	65	68	73	109	2	2	0,15	HJ 311 EC	0,19	9	14
	77,5	101	70,5	2	2	2	65	68	80	109	2	2	0,15	HJ 311 EC	0,19	9	14
	77,5	101	70,5	2	2	-	65	-	80	109	2	2	0,15	-	-	-	-
	77,5	-	106,5	2	2	2	65	104	109	111	2	2	0,12	-	-	-	-
	77,5	101	70,5	2	2	3,5	65	68	73	109	2	2	0,25	HJ 2311 EC	0,19	9	15,5
	77,5	101	70,5	2	2	3,5	65	68	80	109	2	2	0,25	HJ 2311 EC	0,19	9	15,5
77,5	101	70,5	2	2	-	65	-	80	109	2	2	0,25	-	-	-	-	

¹⁾ Permissible axial displacement from the normal position of one bearing ring relative to the other.

5.1 Single row cylindrical roller bearings d 55 – 65 mm

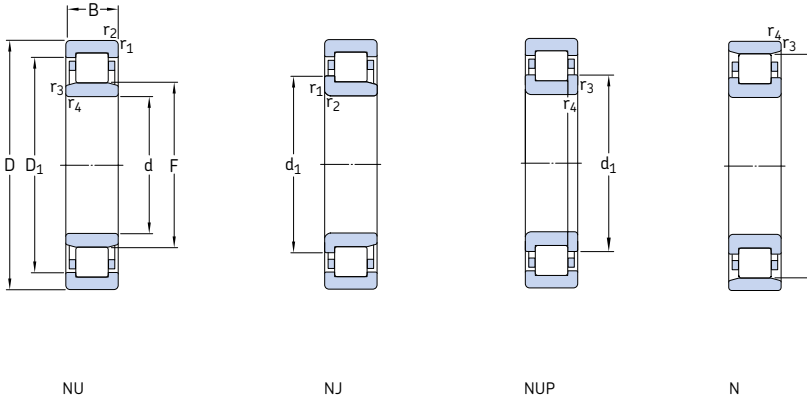

Principal dimensions			Basic load ratings		Fatigue load limit P_u	Speed ratings		Mass	Designations Bearing with standard cage	Alternative standard cage ¹⁾
d	D	B	dynamic C	static C_0		Reference speed	Limiting speed			
mm			kN		kN	r/min		kg	–	
55	140	33	142	140	18,6	5 600	6 300	2,5	NU 411	–
	cont. 140	33	142	140	18,6	5 600	6 300	2,55	NJ 411	–
60	95	18	37,4	44	5,3	8 000	13 000	0,5	NU 1012 ML	–
	110	22	108	102	13,4	6 700	7 500	0,8	* NU 212 ECP	J, M, ML
	110	22	108	102	13,4	6 700	7 500	0,82	* NJ 212 ECP	J, M, ML
	110	22	108	102	13,4	6 700	7 500	0,86	* NUP 212 ECP	J, M, ML
	110	22	108	102	13,4	6 700	7 500	0,81	* N 212 ECP	M
	110	28	146	153	20	6 700	7 500	1,05	* NU 2212 ECP	J, M, ML
	110	28	146	153	20	6 700	7 500	1,1	* NJ 2212 ECP	J, M, ML
	110	28	146	153	20	6 700	7 500	1,1	* NUP 2212 ECP	J, M, ML
	130	31	173	160	21,2	5 600	6 700	1,75	* NU 312 ECP	J, M, ML
	130	31	173	160	21,2	5 600	6 700	1,85	* NJ 312 ECP	J, M, ML
	130	31	173	160	21,2	5 600	6 700	1,9	* NUP 312 ECP	J, M, ML
	130	31	173	160	21,2	5 600	6 700	1,75	* N 312 ECP	J, M
	130	46	260	265	34,5	5 600	6 700	2,75	* NU 2312 ECP	J, M, ML
	130	46	260	265	34,5	5 600	6 700	2,8	* NJ 2312 ECP	J, M, ML
130	46	260	265	34,5	5 600	6 700	2,85	* NUP 2312 ECP	J, M, ML	
65	150	35	168	173	22	5 000	6 000	3	NU 412	–
	150	35	168	173	22	5 000	6 000	3,1	NJ 412	–
	100	18	62,7	81,5	9,8	7 500	7 500	0,45	NU 1013 ECP	–
	120	23	122	118	15,6	6 300	6 700	1,05	* NU 213 ECP	J, M, ML
	120	23	122	118	15,6	6 300	6 700	1,05	* NJ 213 ECP	J, M, ML
	120	23	122	118	15,6	6 300	6 700	1,1	* NUP 213 ECP	J, M, ML
	120	23	122	118	15,6	6 300	6 700	1,05	* N 213 ECP	–
	120	31	170	180	24	6 300	6 700	1,4	* NU 2213 ECP	J, ML
	120	31	170	180	24	6 300	6 700	1,45	* NJ 2213 ECP	J, ML
	120	31	170	180	24	6 300	6 700	1,5	* NUP 2213 ECP	J, ML

¹⁾ When ordering bearings with an alternative standard cage the suffix of the standard cage has to be replaced by the suffix of the alternative cage. For example NU .. ECP becomes NU .. ECML (for permissible speed → page 600).

* SKF Explorer bearing

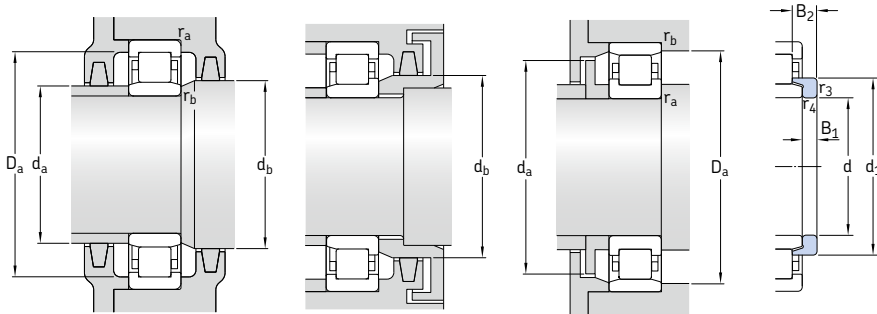

Angle ring

Dimensions							Abutment and fillet dimensions						Calculation factor k_r	Angle ring Designation	Mass	Dimensions	
d	d ₁	D ₁	F, E	r _{1,2} min.	r _{3,4} min.	s ¹⁾	d _a min.	d _a max.	d _b , D _a min.	D _a max.	r _a max.	r _b max.				B ₁	B ₂
mm																	
55	85,2	108	77,2	2,1	2,1	2,6	69	74	79	126	2	2	0,15	–	kg	mm	
	cont. 85,2	108	77,2	2,1	2,1	2,6	69	74	88	126	2	2	0,15	–			
60	–	81,6	69,5	1,1	1	2,9	64,7	68	71	88	1	1	0,15	–			
	77,5	95,7	72	1,5	1,5	1,4	68	70	74	101	1,5	1,5	0,15	HJ 212 EC	0,1	6	10
	77,5	95,7	72	1,5	1,5	1,4	68	70	80	101	1,5	1,5	0,15	HJ 212 EC	0,1	6	10
	77,5	95,7	72	1,5	1,5	–	68	–	80	101	1,5	1,5	0,15	–			
	77,5	–	100	1,5	1,5	1,4	68	98	102	103	1,5	1,5	0,12	–			
	77,5	95,7	72	1,5	1,5	1,4	68	70	74	101	1,5	1,5	0,2	HJ 212 EC	0,1	6	10
	77,5	95,7	72	1,5	1,5	1,4	68	70	80	101	1,5	1,5	0,2	HJ 212 EC	0,1	6	10
	77,5	95,7	72	1,5	1,5	–	68	–	80	101	1,5	1,5	0,2	–			
	84,3	110	77	2,1	2,1	2,1	72	74	79	118	2	2	0,15	HJ 312 EC	0,23	9	14,5
	84,3	110	77	2,1	2,1	2,1	72	74	87	118	2	2	0,15	HJ 312 EC	0,23	9	14,5
84,3	110	77	2,1	2,1	–	72	–	87	118	2	2	0,15	–				
84,3	–	115	2,1	2,1	2,1	72	113	118	119	2	2	0,12	–				
84,3	110	77	2,1	2,1	3,6	72	74	79	118	2	2	0,25	HJ 2312 EC	0,24	9	16	
84,3	110	77	2,1	2,1	3,6	72	74	87	118	2	2	0,25	HJ 2312 EC	0,24	9	16	
84,3	110	77	2,1	2,1	–	72	–	87	118	2	2	0,25	–				
–	117	83	2,1	2,1	2,5	74	80	85	136	2	2	0,15	–				
91,8	117	83	2,1	2,1	2,5	74	80	94	136	2	2	0,15	–				
65	–	88,5	74	1,1	1	1	69,6	72	76	94	1	1	0,1	–			
	84,4	104	78,5	1,5	1,5	1,4	74	76	81	110	1,5	1,5	0,15	HJ 213 EC	0,12	6	10
	84,4	104	78,5	1,5	1,5	1,4	74	76	87	110	1,5	1,5	0,15	HJ 213 EC	0,12	6	10
	84,4	104	78,5	1,5	1,5	–	76	–	87	110	1,5	1,5	0,15	–			
	84,4	–	108,5	1,5	1,5	1,4	74	106	111	112	1,5	1,5	0,12	–			
	84,4	104	78,5	1,5	1,5	1,9	74	76	81	110	1,5	1,5	0,2	HJ 2213 EC	0,3	6	18
	84,4	104	78,5	1,5	1,5	1,9	74	76	87	110	1,5	1,5	0,2	HJ 2213 EC	0,3	6	18
	84,4	104	78,5	1,5	1,5	–	74	–	87	110	1,5	1,5	0,2	–			

¹⁾ Permissible axial displacement r from the normal position of one bearing ring relative to the other.

5.1 Single row cylindrical roller bearings d 65 – 70 mm

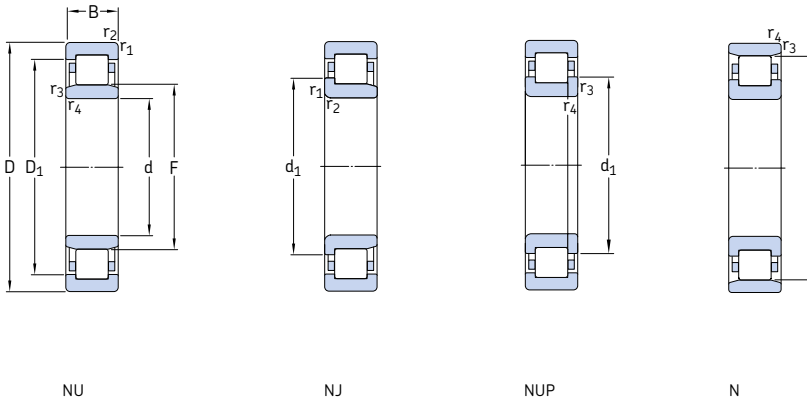

Principal dimensions			Basic load ratings		Fatigue load limit P_u	Speed ratings		Mass	Designations Bearing with standard cage	Alternative standard cage ¹⁾	
d	D	B	dynamic C	static C_0		Reference speed	Limiting speed				
mm			kN		kN	r/min		kg	–		
65 cont.	140	33	212	196	25,5	5 300	6 000	2,2	* NU 313 ECP	J, M, ML, PH	
	140	33	212	196	25,5	5 300	6 000	2,3	* NJ 313 ECP	J, M, ML, PH	
	140	33	212	196	25,5	5 300	6 000	2,35	* NUP 313 ECP	J, M, ML, PH	
	140	33	212	196	25,5	5 300	6 000	2,2	* N 313 ECP	M	
	140	48	285	290	38	5 300	6 000	3,2	* NU 2313 ECP	ML, PH	
	140	48	285	290	38	5 300	6 000	3,35	* NJ 2313 ECP	ML, PH	
	140	48	285	290	38	5 300	6 000	3,45	* NUP 2313 ECP	ML, PH	
	160	37	183	190	24	4 800	5 600	3,55	NU 413	M	
	160	37	183	190	24	4 800	5 600	3,65	NJ 413	M	
	70	110	20	76,5	93	12	7 000	7 000	0,62	NU 1014 ECP	–
		125	24	137	137	18	6 000	6 300	1,15	* NU 214 ECP	J, M, ML, PH
		125	24	137	137	18	6 000	6 300	1,2	* NJ 214 ECP	J, M, ML, PH
125		24	137	137	18	6 000	6 300	1,2	* NUP 214 ECP	J, M, ML, PH	
125		24	137	137	18	6 000	6 300	1,1	* N 214 ECP	–	
125		31	180	193	25,5	6 000	6 300	1,5	* NU 2214 ECP	J, M, ML, PH	
125		31	180	193	25,5	6 000	6 300	1,55	* NJ 2214 ECP	J, M, ML, PH	
125		31	180	193	25,5	6 000	6 300	1,55	* NUP 2214 ECP	J, M, ML, PH	
150		35	236	228	29	4 800	5 600	2,7	* NU 314 ECP	J, M, ML	
150		35	236	228	29	4 800	5 600	2,75	* NJ 314 ECP	J, M, ML	
150		35	236	228	29	4 800	5 600	2,85	* NUP 314 ECP	J, M, ML	
150		35	236	228	29	4 800	5 600	2,65	* N 314 ECP	J, M	
150		51	315	325	41,5	4 800	5 600	3,95	* NU 2314 ECP	J, ML, PH	
150		51	315	325	41,5	4 800	5 600	4	* NJ 2314 ECP	J, ML, PH	
150		51	315	325	41,5	4 800	5 600	4,15	* NUP 2314 ECP	J, ML, PH	
180		42	229	240	30	4 300	5 000	5,35	NU 414	MA	
180		42	229	240	30	4 300	5 000	5,45	NJ 414	MA	

¹⁾ When ordering bearings with an alternative standard cage the suffix of the standard cage has to be replaced by the suffix of the alternative cage. For example NU .. ECP becomes NU .. ECML (for permissible speed → page 600).

* SKF Explorer bearing

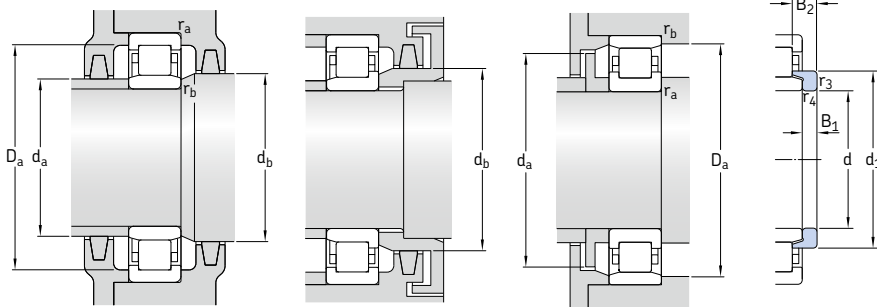

Angle ring

Dimensions							Abutment and fillet dimensions					Calculation factor k_r	Angle ring Designation	Mass	Dimensions			
d	d_1	D_1	F, E	$r_{1,2}$	$r_{3,4}$	$s^{1)}$	d_a min.	d_a max.	d_b, D_a min.	D_a max.	r_a max.				r_b max.	B_1	B_2	
mm	mm	mm	mm	mm	mm	mm	mm	mm	mm	mm	mm	mm	mm	mm	kg	mm	mm	
65 cont.	90,5	119	82,5	2,1	2,1	2,2	77	80	85	127	2	2	0,15	HJ 313 EC	0,27	10	15,5	
	90,5	119	82,5	2,1	2,1	2,2	77	80	93	127	2	2	0,15	HJ 313 EC	0,27	10	15,5	
	90,5	119	82,5	2,1	2,1	-	77	-	93	127	2	2	0,15	-	-	-	-	
	90,5	-	124,5	2,1	2,1	2,2	77	122	127	129	2	2	0,12	-	-	-	-	
	90,5	119	82,5	2,1	2,1	4,7	77	80	85	127	2	2	0,25	HJ 2313 EC	0,3	10	18	
	90,5	119	82,5	2,1	2,1	4,7	77	80	93	127	2	2	0,25	HJ 2313 EC	0,3	10	18	
	90,5	119	82,5	2,1	2,1	-	77	-	93	127	2	2	0,25	-	-	-	-	
	98,5	125	89,3	2,1	2,1	2,6	78	86	91	146	2	2	0,15	HJ 413	0,42	11	18	
	98,5	125	89,3	2,1	2,1	2,6	78	86	101	146	2	2	0,15	HJ 413	0,42	11	18	
	70	84	97,5	79,5	1,1	1	1,3	74,6	78	82	104	1	1	0,1	HJ 1014 EC	0,082	5	10
		89,4	109	83,5	1,5	1,5	1,2	79	81	86	115	1,5	1,5	0,15	HJ 214 EC	0,15	7	11
		89,4	109	83,5	1,5	1,5	1,2	79	81	92	115	1,5	1,5	0,15	HJ 214 EC	0,15	7	11
89,4		109	83,5	1,5	1,5	-	79	-	92	115	1,5	1,5	0,15	-	-	-	-	
89,4		-	113,5	1,5	1,5	1,2	79	111	116	117	1,5	1,5	0,12	-	-	-	-	
89,4		109	83,5	1,5	1,5	1,7	79	81	86	115	1,5	1,5	0,2	HJ 2214 EC	0,15	7	11,5	
89,4		109	83,5	1,5	1,5	1,7	79	81	92	115	1,5	1,5	0,2	HJ 2214 EC	0,15	7	11,5	
89,4		109	83,5	1,5	1,5	-	79	-	92	115	1,5	1,5	0,2	-	-	-	-	
97,3		127	89	2,1	2,1	1,8	82	86	92	137	2	2	0,15	HJ 314 EC	0,32	10	15,5	
97,3		127	89	2,1	2,1	1,8	82	86	100	137	2	2	0,15	HJ 314 EC	0,32	10	15,5	
97,3		127	89	2,1	2,1	-	82	-	100	137	2	2	0,15	-	-	-	-	
97,3		-	133	2,1	2,1	1,8	82	130	136	138	2	2	0,12	-	-	-	-	
97,3		127	89	2,1	2,1	4,8	82	86	92	137	2	2	0,25	HJ 2314 EC	0,35	10	18,5	
97,3		127	89	2,1	2,1	4,8	82	86	100	137	2	2	0,25	HJ 2314 EC	0,35	10	18,5	
97,3		127	89	2,1	2,1	-	82	-	100	137	2	2	0,25	-	-	-	-	
110		140	100	3	3	3,5	87	97	102	164	2,5	2,5	0,15	HJ 414	0,61	12	20	
110		140	100	3	3	3,5	87	97	113	164	2,5	2,5	0,15	HJ 414	0,61	12	20	

¹⁾ Permissible axial displacement from the normal position of one bearing ring relative to the other.

5.1 Single row cylindrical roller bearings d 75 – 80 mm

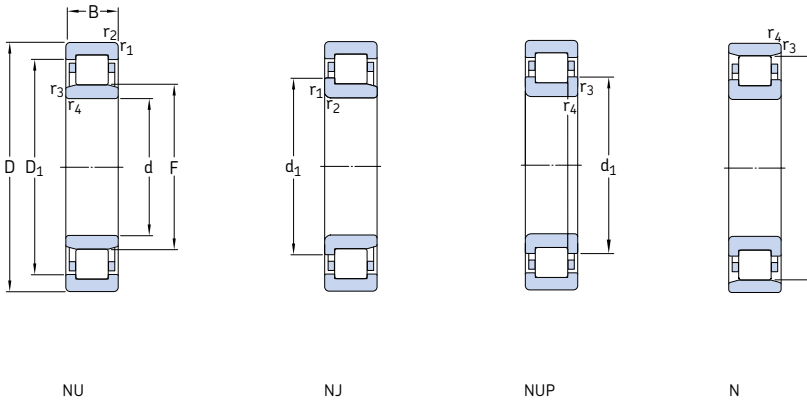

Principal dimensions	Basic load ratings		Fatigue load limit P_u	Speed ratings		Mass	Designations Bearing with standard cage	Alternative standard cage ¹⁾		
	dynamic C	static C_0		Reference speed	Limiting speed					
d	D	B								
mm			kN	kN	r/min	kg	–			
75	115	20	58,3	71	8,5	6 700	10 000	0,75	NU 1015 ML	M
	130	25	150	156	20,4	5 600	6 000	1,25	* NU 215 ECP	J, M, ML
	130	25	150	156	20,4	5 600	6 000	1,3	* NJ 215 ECP	J, M, ML
	130	25	150	156	20,4	5 600	6 000	1,3	* NUP 215 ECP	J, M, ML
	130	25	150	156	20,4	5 600	6 000	1,2	* N 215 ECP	–
	130	31	186	208	27	5 600	6 000	1,6	* NU 2215 ECP	J, ML, PH
	130	31	186	208	27	5 600	6 000	1,6	* NJ 2215 ECP	J, ML, PH
	130	31	186	208	27	5 600	6 000	1,6	* NUP 2215 ECP	J, ML, PH
	160	37	280	265	33,5	4 500	5 300	3,3	* NU 315 ECP	J, M, ML
	160	37	280	265	33,5	4 500	5 300	3,35	* NJ 315 ECP	J, M, ML
	160	37	280	265	33,5	4 500	5 300	3,45	* NUP 315 ECP	J, M, PH
	160	37	280	265	33,5	4 500	5 300	3,3	* N 315 ECP	M
	160	55	380	400	50	4 500	5 300	4,8	* NU 2315 ECP	J, ML
	160	55	380	400	50	4 500	5 300	5	* NJ 2315 ECP	J, ML
160	55	380	400	50	4 500	5 300	5	* NUP 2315 ECP	J, ML	
80	190	45	264	280	34	4 000	4 800	6,2	NU 415	–
	190	45	264	280	34	4 000	4 800	6,4	NJ 415	–
	125	22	64,4	78	9,8	6 300	6 300	0,88	NU 1016	–
	125	22	99	127	16,3	6 000	9 500	1,05	NJ 1016 ECML	–
	140	26	160	166	21,2	5 300	5 600	1,55	* NU 216 ECP	J, M, ML
	140	26	160	166	21,2	5 300	5 600	1,55	* NJ 216 ECP	J, M, ML
	140	26	160	166	21,2	5 300	5 600	1,55	* NUP 216 ECP	J, M, ML
	140	26	160	166	21,2	5 300	5 600	1,55	* N 216 ECP	–
	140	33	212	245	31	5 300	5 600	2	* NU 2216 ECP	J, M, ML
	140	33	212	245	31	5 300	5 600	2,05	* NJ 2216 ECP	J, M, ML
	140	33	212	245	31	5 300	5 600	2,05	* NUP 2216 ECP	J, M, ML
	170	39	300	290	36	4 300	5 000	3,85	* NU 316 ECP	J, M, ML
	170	39	300	290	36	4 300	5 000	4	* NJ 316 ECP	J, M, ML

¹⁾ When ordering bearings with an alternative standard cage the suffix of the standard cage has to be replaced by the suffix of the alternative cage. For example NU .. ECP becomes NU .. ECML (for permissible speed → page 600).

* SKF Explorer bearing

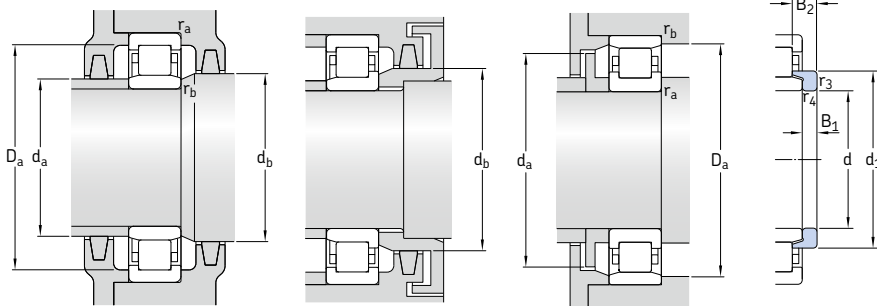

Angle ring

Dimensions							Abutment and fillet dimensions						Calculation factor k_r	Angle ring Designation	Mass	Dimensions	
d	d ₁	D ₁	F, E	r _{1,2} min.	r _{3,4} min.	s ¹⁾	d _a min.	d _a max.	d _b , D _a min.	D _a max.	r _a max.	r _b max.				B ₁	B ₂
mm							mm						-	-	kg	mm	
75	-	101	85	1,1	1	3	80	83	87	109	1	1	0,15	-			
	94,3	114	88,5	1,5	1,5	1,2	84	86	91	121	1,5	1,5	0,15	HJ 215 EC	0,16	7	11
	94,3	114	88,5	1,5	1,5	1,2	84	86	97	121	1,5	1,5	0,15	HJ 215 EC	0,16	7	11
	94,3	114	88,5	1,5	1,5	-	84	-	97	121	1,5	1,5	0,15	-			
	94,3	-	118,5	1,5	1,5	1,2	84	116	121	122	1,5	1,5	0,12	-			
	-	114	88,5	1,5	1,5	1,7	84	86	91	121	1,5	1,5	0,2	-			
	94,3	114	88,5	1,5	1,5	1,7	84	86	97	121	1,5	1,5	0,2	-			
	94,3	114	88,5	1,5	1,5	-	84	-	97	121	1,5	1,5	0,2	-			
	104	136	95	2,1	2,1	1,8	87	92	97	148	2	2	0,15	HJ 315 EC	0,39	11	16,5
	104	136	95	2,1	2,1	1,8	87	92	107	148	2	2	0,15	HJ 315 EC	0,39	11	16,5
	104	136	95	2,1	2,1	-	87	-	107	148	2	2	0,15	-			
	104	-	143	2,1	2,1	1,8	87	140	146	148	2	2	0,12	-			
	104	136	95	2,1	2,1	4,8	87	92	97	148	2	2	0,25	HJ 2315 EC	0,42	11	19,5
	104	136	95	2,1	2,1	4,8	87	92	107	148	2	2	0,25	HJ 2315 EC	0,42	11	19,5
	104	136	95	2,1	2,1	-	87	-	107	148	2	2	0,25	-			
	116	148	104,5	3	3	3,8	91	101	107	174	2,5	2,5	0,15	HJ 415	0,71	13	21,5
	116	148	104,5	3	3	3,8	91	101	119	174	2,5	2,5	0,15	HJ 415	0,71	13	21,5
80	-	109	91,5	1,1	1	3,3	86	90	94	119	1	1	0,1	-			
	96,2	111	91,5	1,1	1	1,5	86	90	99	119	1	1	0,15	-			
	101	123	95,3	2	2	1,4	90	93	98	129	2	2	0,15	HJ 216 EC	0,21	8	12,5
	101	123	95,3	2	2	1,4	90	93	104	129	2	2	0,15	HJ 216 EC	0,21	8	12,5
	101	123	95,3	2	2	-	90	-	104	129	2	2	0,15	-			
	101	-	127,3	2	2	1,4	90	125	130	131	2	2	0,12	-			
	101	123	95,3	2	2	1,4	90	93	98	129	2	2	0,2	HJ 216 EC	0,21	8	12,5
	101	123	95,3	2	2	1,4	90	93	104	129	2	2	0,2	HJ 216 EC	0,21	8	12,5
	101	123	95,3	2	2	-	90	-	104	129	2	2	0,2	-			
	110	144	101	2,1	2,1	2,1	92	98	104	157	2	2	0,15	HJ 316 EC	0,44	11	17
	110	144	101	2,1	2,1	2,1	92	98	113	157	2	2	0,15	HJ 316 EC	0,44	11	17

¹⁾ Permissible axial displacement from the normal position of one bearing ring relative to the other.

5.1 Single row cylindrical roller bearings d 80 – 85 mm

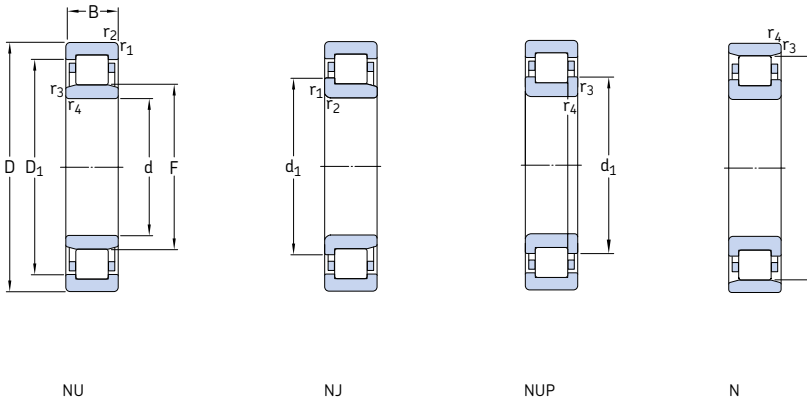

Principal dimensions	Basic load ratings		Fatigue load limit P_u	Speed ratings		Mass	Designations Bearing with standard cage	Alternative standard cage ¹⁾			
	dynamic	static C_0		Reference speed	Limiting speed						
d	D	B	C								
mm			kN	kN	r/min	kg	-				
80	170	39	300	290	36	4 300	5 000	4,1	* NUP 316 ECP	J, M, ML	
	170	39	300	290	36	4 300	5 000	3,9	* N 316 ECP	M	
	170	58	415	440	55	4 300	5 000	5,85	* NU 2316 ECP	M, ML	
	170	58	415	440	55	4 300	5 000	5,95	* NJ 2316 ECP	M, ML	
	170	58	415	440	55	4 300	5 000	6	* NUP 2316 ECP	M, ML	
	200	48	303	320	39	3 800	4 500	7,25	NU 416	M	
	200	48	303	320	39	3 800	4 500	7,25	NJ 416	-	
	85	130	22	68,2	86,5	10,8	6 000	9 000	1,05	NU 1017 ML	M
	150	28	190	200	25	4 800	5 300	1,9	* NU 217 ECP	J, M, ML	
	150	28	190	200	25	4 800	5 300	1,9	* NJ 217 ECP	J, M, ML	
150	28	190	200	25	4 800	5 300	1,9	* NUP 217 ECP	J, M, ML		
150	28	190	200	25	4 800	5 300	1,9	* N 217 ECP	M		
150	36	250	280	34,5	4 800	5 300	2,5	* NU 2217 ECP	J, M, ML		
150	36	250	280	34,5	4 800	5 300	2,55	* NJ 2217 ECP	J, M, ML		
150	36	250	280	34,5	4 800	5 300	2,6	* NUP 2217 ECP	J, M, ML		
180	41	340	335	41,5	4 000	4 800	4,65	* NU 317 ECP	J, M, ML		
180	41	340	335	41,5	4 000	4 800	4,65	* NJ 317 ECP	J, M, ML		
180	41	340	335	41,5	4 000	4 800	4,9	* NUP 317 ECP	J, M, ML		
180	41	340	335	41,5	4 000	4 800	4,55	* N 317 ECP	M		
180	60	455	490	60	4 000	4 800	6,85	* NU 2317 ECP	J, M, ML		
180	60	455	490	60	4 000	4 800	7	* NJ 2317 ECP	J, M, ML		
180	60	455	490	60	4 000	4 800	7	* NUP 2317 ECP	J, M, ML		
210	52	319	335	39	3 600	4 300	8,7	NU 417	M		
210	52	319	335	39	3 600	4 300	8,9	NJ 417	-		

¹⁾ When ordering bearings with an alternative standard cage the suffix of the standard cage has to be replaced by the suffix of the alternative cage. For example NU .. ECP becomes NU .. ECML (for permissible speed → page 600).

* SKF Explorer bearing

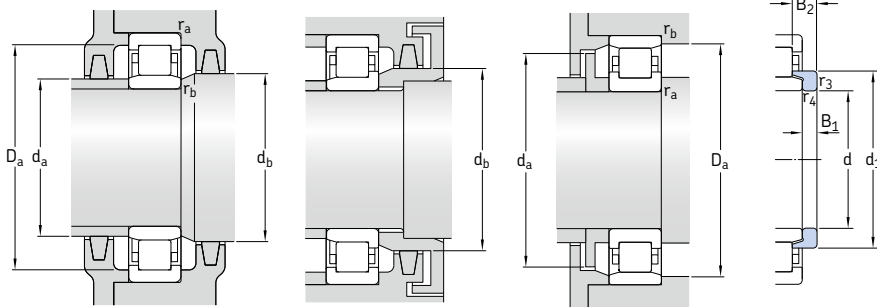

Angle ring

Dimensions							Abutment and fillet dimensions					Calculation factor k_r	Angle ring Designation	Mass	Dimensions		
d	d ₁	D ₁	F, E	r _{1,2} min.	r _{3,4} min.	s ¹⁾	d _a min.	d _a max.	d _b , D _a min.	D _a max.	r _a max.				r _b max.	B ₁	B ₂
mm															kg	mm	
80	110	144	101	2,1	2,1	–	92	–	113	157	2	2	0,15	–			
	cont.	110	–	151	2,1	2,1	2,1	92	148	154	157	2	2	0,12	–		
	110	144	101	2,1	2,1	5,1	92	98	104	157	2	2	0,25	HJ 2316 EC	0,48	11	20
	110	144	101	2,1	2,1	5,1	92	98	113	157	2	2	0,25	HJ 2316 EC	0,48	11	20
	110	144	101	2,1	2,1	–	92	–	113	157	2	2	0,25	–			
	122	157	110	3	3	3,7	96	107	112	184	2,5	2,5	0,15	HJ 416	0,8	13	22
	122	157	110	3	3	3,7	96	107	125	184	2,5	2,5	0,15	HJ 416	0,8	13	22
85	–	114	96,5	1,1	1	3,3	91	94	99	123	1	1	0,15	–			
	107	131	100,5	2	2	1,5	96	98	103	138	2	2	0,15	HJ 217 EC	0,24	8	12,5
	107	131	100,5	2	2	1,5	96	98	110	138	2	2	0,15	HJ 217 EC	0,24	8	12,5
	107	131	100,5	2	2	–	96	–	110	138	2	2	0,15	–			
	107	–	136,5	2	2	1,5	96	134	139	140	2	2	0,12	–			
	–	131	100,5	2	2	2	96	98	103	138	2	2	0,2	–			
	107	131	100,5	2	2	2	96	98	110	138	2	2	0,2	–			
	107	131	100,5	2	2	–	96	–	110	138	2	2	0,2	–			
	117	153	108	3	3	2,3	99	105	111	165	2,5	2,5	0,15	HJ 317 EC	0,55	12	18,5
	117	153	108	3	3	2,3	99	105	120	165	2,5	2,5	0,15	HJ 317 EC	0,55	12	18,5
	117	153	108	3	3	–	99	–	120	165	2,5	2,5	0,15	–			
	117	–	160	3	3	2,3	99	157	163	166	2,5	2,5	0,12	–			
	117	153	108	3	3	5,8	99	105	111	165	2,5	2,5	0,25	HJ 2317 EC	0,59	12	22
	117	153	108	3	3	5,8	99	105	120	165	2,5	2,5	0,25	HJ 2317 EC	0,59	12	22
	117	153	108	3	3	–	99	–	120	165	2,5	2,5	0,25	–			
	126	163	113	4	4	3,8	103	109	115	191	3	3	0,15	HJ 417	0,88	14	24
	126	163	113	4	4	3,8	103	109	129	191	3	3	0,15	HJ 417	0,88	14	24

¹⁾ Permissible axial displacement from the normal position of one bearing ring relative to the other.

5.1 Single row cylindrical roller bearings d 90 – 95 mm

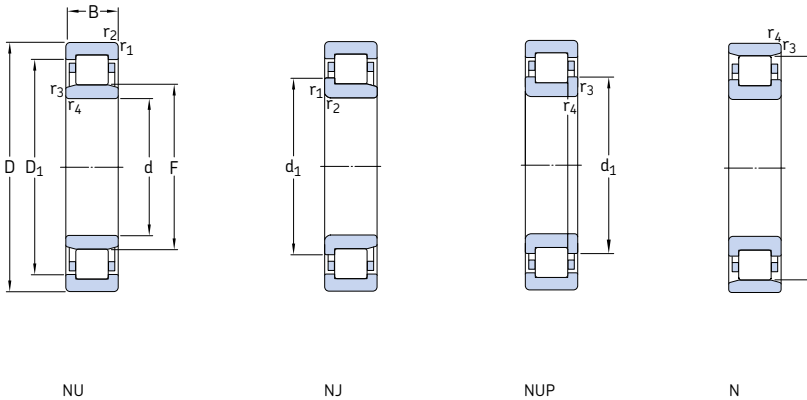

Principal dimensions			Basic load ratings		Fatigue load limit P_u	Speed ratings		Mass	Designations Bearing with standard cage	Alternative standard cage ¹⁾
d	D	B	dynamic C	static C_0		Reference speed	Limiting speed			
mm			kN		kN	r/min	kg	-		
90	140	24	80,9	104	12,7	5 600	8 500	1,35	NU 1018 ML	M
	160	30	208	220	27	4 500	5 000	2,3	* NU 218 ECP	J, M, ML
	160	30	208	220	27	4 500	5 000	2,3	* NJ 218 ECP	J, M, ML
	160	30	208	220	27	4 500	5 000	2,45	* NUP 218 ECP	J, M, ML
	160	30	208	220	27	4 500	5 000	2,3	* N 218 ECP	M
	160	40	280	315	39	4 500	5 000	3,15	* NU 2218 ECP	J, M, ML
	160	40	280	315	39	4 500	5 000	3,25	* NJ 2218 ECP	J, M, ML
	160	40	280	315	39	4 500	5 000	3,3	* NUP 2218 ECP	J, M, ML
	190	43	365	360	43	3 800	4 500	5,25	* NU 318 ECP	J, M, ML
	190	43	365	360	43	3 800	4 500	5,45	* NJ 318 ECP	J, M, ML
	190	43	365	360	43	3 800	4 500	5,55	* NUP 318 ECJ	M, ML, P
	190	43	365	360	43	3 800	4 500	5,3	* N 318 ECP	M
	190	64	500	540	65,5	3 800	4 500	8	* NU 2318 ECP	J, M, ML
	190	64	500	540	65,5	3 800	4 500	8,15	* NJ 2318 ECP	J, M, ML
	190	64	500	540	65,5	3 800	4 500	8,25	* NUP 2318 ECP	J, M, ML
		225	54	380	415	48	3 400	4 000	10,5	NU 418
95	145	24	84,2	110	13,2	5 300	8 000	1,45	NU 1019 ML	M
	170	32	255	265	32,5	4 300	4 800	2,85	* NU 219 ECP	J, M, ML
	170	32	255	265	32,5	4 300	4 800	2,9	* NJ 219 ECP	J, M, ML
	170	32	255	265	32,5	4 300	4 800	2,9	* NUP 219 ECP	J, M, ML
	170	32	255	265	32,5	4 300	4 800	2,85	* N 219 ECP	-
	170	43	325	375	45,5	4 300	4 800	3,8	* NU 2219 ECP	J, ML
	170	43	325	375	45,5	4 300	4 800	3,95	* NJ 2219 ECP	J, ML
	170	43	325	375	45,5	4 300	4 800	4	* NUP 2219 ECP	J, ML
	200	45	390	390	46,5	3 600	4 300	6,2	* NU 319 ECP	J, M, ML
	200	45	390	390	46,5	3 600	4 300	6,3	* NJ 319 ECP	J, M, ML
	200	45	390	390	46,5	3 600	4 300	6,3	* NUP 319 ECP	J, M, ML
	200	45	390	390	46,5	3 600	4 300	6,2	* N 319 ECP	M

¹⁾ When ordering bearings with an alternative standard cage the suffix of the standard cage has to be replaced by the suffix of the alternative cage. For example NU .. ECP becomes NU .. ECML (for permissible speed → page 600).

* SKF Explorer bearing

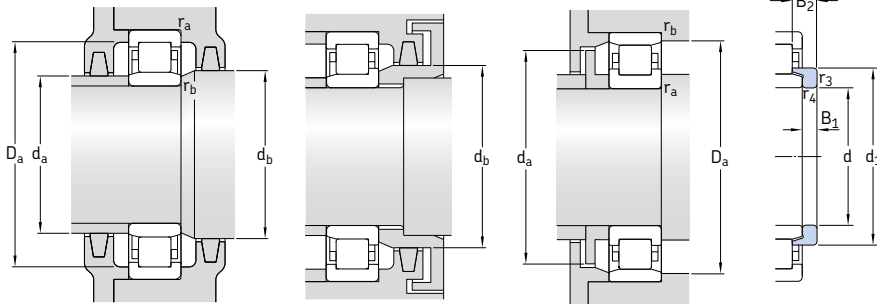

Angle ring

Dimensions							Abutment and fillet dimensions						Calculation factor k_r	Angle ring Designation	Mass	Dimensions	
d	d_1	D_1	F, E	$r_{1,2}$	$r_{3,4}$	$s^{1)}$	d_a min.	d_a max.	d_b, D_a min.	D_a max.	r_a max.	r_b max.				B_1	B_2
mm																	
90	-	122	103	1,5	1,1	3,5	96	101	106	133	1,5	1	0,15	-			
	114	140	107	2	2	1,8	101	104	110	149	2	2	0,15	HJ 218 EC	0,31	9	14
	114	140	107	2	2	1,8	101	104	117	149	2	2	0,15	HJ 218 EC	0,31	9	14
	114	140	107	2	2	-	101	-	117	149	2	2	0,15	-			
	114	-	145	2	2	1,8	101	142	148	149	2	2	0,12	-			
	114	140	107	2	2	2,6	101	104	110	149	2	2	0,2	HJ 2218 EC	0,33	9	15
	114	140	107	2	2	2,6	101	104	117	149	2	2	0,2	HJ 2218 EC	0,33	9	15
	114	140	107	2	2	-	101	-	117	149	2	2	0,2	-			
	124	162	113,5	3	3	2,5	104	110	116	175	2,5	2,5	0,15	HJ 318 EC	0,62	12	18,5
	124	162	113,5	3	3	2,5	104	110	127	175	2,5	2,5	0,15	HJ 318 EC	0,62	12	18,5
	124	162	113,5	3	3	-	104	-	127	175	2,5	2,5	0,15	-			
	124	-	169,5	3	3	2,5	104	166	173	175	2,5	2,5	0,12	-			
	124	162	113,5	3	3	6	104	110	116	175	2,5	2,5	0,25	HJ 2318 EC	0,66	12	22
	124	162	113,5	3	3	6	104	110	127	175	2,5	2,5	0,25	HJ 2318 EC	0,66	12	22
	124	162	113,5	3	3	-	104	-	127	175	2,5	2,5	0,25	-			
	-	176	123,5	4	4	4,9	108	120	126	205	3	3	0,15	-			
95	-	127	108	1,5	1,1	3,5	101	106	111	138	1,5	1	0,15	-			
	120	149	112,5	2,1	2,1	1,7	107	110	115	157	2	2	0,15	HJ 219 EC	0,33	9	14
	120	149	112,5	2,1	2,1	1,7	107	110	123	157	2	2	0,15	HJ 219 EC	0,33	9	14
	120	149	112,5	2,1	2,1	-	107	-	123	157	2	2	0,15	-			
	120	-	154,5	2,1	2,1	1,7	107	152	157	159	2	2	0,12	-			
	-	149	112,5	2,1	2,1	3	107	110	115	157	2	2	0,2	-			
	120	149	112,5	2,1	2,1	3	107	110	123	157	2	2	0,2	-			
	120	149	112,5	2,1	2,1	-	107	-	123	157	2	2	0,2	-			
	132	170	121,5	3	3	2,9	110	118	125	185	2,5	2,5	0,15	HJ 319 EC	0,78	13	20,5
	132	170	121,5	3	3	2,9	110	118	135	185	2,5	2,5	0,15	HJ 319 EC	0,78	13	20,5
	132	170	121,5	3	3	-	110	-	135	185	2,5	2,5	0,15	-			
	132	-	177,5	3	3	2,9	110	174	181	185	2,5	2,5	0,12	-			

¹⁾ Permissible axial displacement from the normal position of one bearing ring relative to the other.

5.1 Single row cylindrical roller bearings d 95 – 105 mm

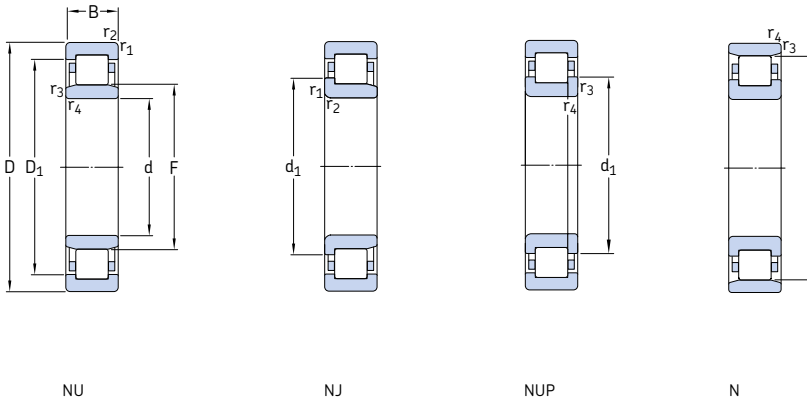

Principal dimensions			Basic load ratings		Fatigue load limit P_u	Speed ratings		Mass kg	Designations Bearing with standard cage	Alternative standard cage ¹⁾
d	D	B	dynamic C	static C_0		Reference speed	Limiting speed			
mm			kN		kN	r/min		kg	–	
95 cont.	200	67	530	585	69,5	3 600	4 300	9,35	* NU 2319 ECP	J, ML
	200	67	530	585	69,5	3 600	4 300	9,5	* NJ 2319 ECP	J, ML
	200	67	530	585	69,5	3 600	4 300	9,8	* NUP 2319 ECP	J, ML
	240	55	413	455	52	3 200	3 600	13,5	NU 419 M	–
100	150	24	85,8	114	13,7	5 000	7 500	1,45	NU 1020 ML	M
	180	34	285	305	36,5	4 000	4 500	3,4	* NU 220 ECP	J, M, ML
	180	34	285	305	36,5	4 000	4 500	3,45	* NJ 220 ECP	J, M, ML
	180	34	285	305	36,5	4 000	4 500	3,6	* NUP 220 ECP	J, M, ML
	180	34	285	305	36,5	4 000	4 500	3,45	* N 220 ECP	–
	180	46	380	450	54	4 000	4 500	4,75	* NU 2220 ECP	J, M, ML
	180	46	380	450	54	4 000	4 500	4,8	* NJ 2220 ECP	J, M, ML
	180	46	380	450	54	4 000	4 500	4,9	* NUP 2220 ECP	J, M, ML
	215	47	450	440	51	3 200	3 800	7,45	* NU 320 ECP	J, M, ML
	215	47	450	440	51	3 200	3 800	7,8	* NJ 320 ECP	J, M, ML
	215	47	450	440	51	3 200	3 800	7,8	* NUP 320 ECJ	J, M, ML
	215	47	450	440	51	3 200	3 800	7,55	* N 320 ECP	M
	215	73	670	735	85	3 200	3 800	12	* NU 2320 ECP	J, M, ML
	215	73	670	735	85	3 200	3 800	12	* NJ 2320 ECP	J, M, ML
	215	73	670	735	85	3 200	3 800	12,5	* NUP 2320 ECP	J, M, ML
	250	58	457	520	58,5	3 000	3 600	15,5	NU 420 M	–
105	160	26	101	137	16	4 800	7 000	1,9	NU 1021 ML	M
	190	36	300	315	36,5	3 800	4 300	3,95	* NU 221 ECP	J, ML
	190	36	300	315	36,5	3 800	4 300	4	* NJ 221 ECP	J, ML
	190	36	300	315	36,5	3 800	4 300	4,2	* NUP 221 ECP	J, ML
	190	36	300	315	36,5	3 800	4 300	3,9	* N 221 ECP	–
	225	49	500	500	57	3 200	3 800	8,55	* NU 321 ECP	J, ML
	225	49	500	500	57	3 200	3 800	8,75	* NJ 321 ECJ	J, ML

¹⁾ When ordering bearings with an alternative standard cage the suffix of the standard cage has to be replaced by the suffix of the alternative cage. For example NU .. ECP becomes NU .. ECML (for permissible speed → page 600).

* SKF Explorer bearing

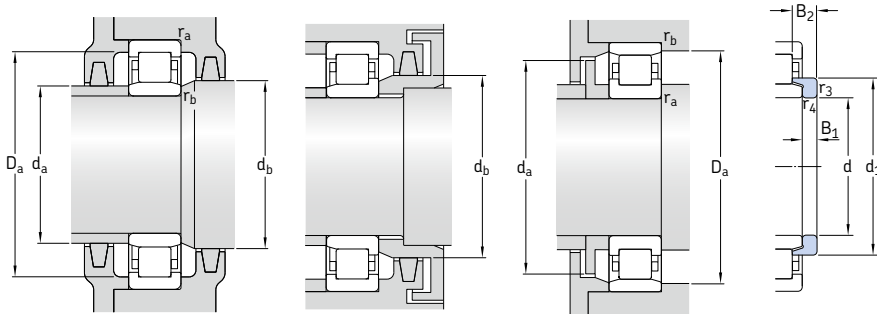

Angle ring

Dimensions							Abutment and fillet dimensions					Calculation factor k_r	Angle ring Designation	Mass	Dimensions		
d	d ₁	D ₁	F, E	r _{1,2}	r _{3,4}	s ¹⁾	d _a min.	d _a max.	d _b , D _a min.	D _a max.	r _a max.				r _b max.	B ₁	B ₂
mm							mm					-	-	kg	mm		
95 cont.	132	170	121,5	3	3	6,9	110	118	125	185	2,5	2,5	0,25	HJ 2319 EC	0,76	13	24,5
	132	170	121,5	3	3	6,9	110	118	135	185	2,5	2,5	0,25	HJ 2319 EC	0,76	13	24,5
	132	170	121,5	3	3	-	110	-	135	185	2,5	2,5	0,25	-	-	-	-
-	186	133,5	4	4	5	114	130	136	220	3	3	0,15	-	-	-	-	-
100	-	132	113	1,5	1,1	3,5	106	111	116	143	1,5	1	0,15	-	-	-	-
	127	157	119	2,1	2,1	1,7	113	116	122	167	2	2	0,15	HJ 220 EC	0,43	10	15
	127	157	119	2,1	2,1	1,7	113	116	130	167	2	2	0,15	HJ 220 EC	0,43	10	15
	127	157	119	2,1	2,1	-	113	-	130	167	2	2	0,15	-	-	-	-
	127	-	163	2,1	2,1	1,7	113	160	166	168	2	2	0,12	-	-	-	-
	127	157	119	2,1	2,1	2,5	113	116	122	167	2	2	0,2	HJ 2220 EC	0,43	10	16
	127	157	119	2,1	2,1	2,5	113	116	130	167	2	2	0,2	HJ 2220 EC	0,43	10	16
	127	157	119	2,1	2,1	-	113	-	130	167	2	2	0,2	-	-	-	-
	139	182	127,5	3	3	2,9	114	124	131	199	2,5	2,5	0,15	HJ 320 EC	0,87	13	20,5
	139	182	127,5	3	3	2,9	114	124	142	199	2,5	2,5	0,15	HJ 320 EC	0,87	13	20,5
	139	182	127,5	3	3	-	114	-	142	199	2,5	2,5	0,15	-	-	-	-
	139	-	191,5	3	3	2,9	114	188	195	200	2,5	2,5	0,12	-	-	-	-
139	182	127,5	3	3	5,9	114	124	131	199	2,5	2,5	0,25	HJ 2320 EC	0,91	13	23,5	
139	182	127,5	3	3	5,9	114	124	142	199	2,5	2,5	0,25	HJ 2320 EC	0,91	13	23,5	
139	182	127,5	3	3	-	114	-	142	199	2,5	2,5	0,25	-	-	-	-	
153	195	139	4	4	4,9	119	135	142	230	3	3	0,15	HJ 420	1,5	16	27	
105	-	140	119,5	2	1,1	3,8	111	117	122	151	2	1	0,15	-	-	-	-
	134	164	125	2,1	2,1	2	117	122	128	177	2	2	0,15	HJ 221 EC	0,5	10	17,5
	134	164	125	2,1	2,1	2	117	122	137	177	2	2	0,15	HJ 221 EC	0,5	10	17,5
	134	164	125	2,1	2,1	-	117	-	137	177	2	2	0,15	-	-	-	-
	134	-	173	2,1	2,1	2	117	170	176	178	2	2	0,12	-	-	-	-
	-	190	133	3	3	3,4	119	129	136	209	2,5	2,5	0,15	-	-	-	-
145	190	133	3	3	3,4	119	129	148	209	2,5	2,5	0,15	-	-	-	-	

¹⁾ Permissible axial displacement from the normal position of one bearing ring relative to the other.

5.1 Single row cylindrical roller bearings

d 105 – 120 mm

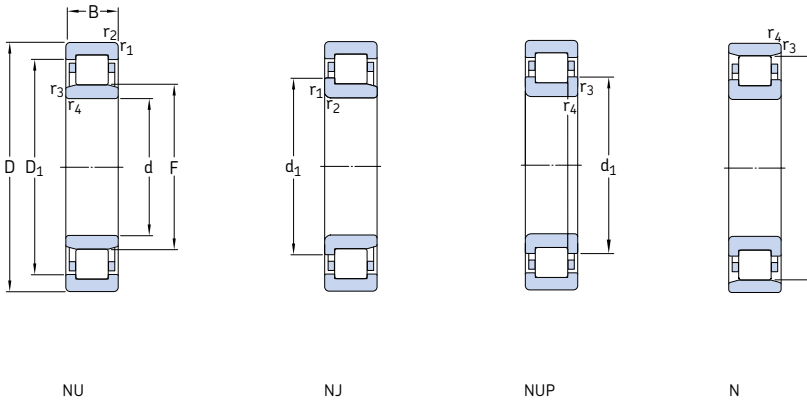

Principal dimensions	Basic load ratings		Fatigue load limit P_u	Speed ratings		Mass	Designations	Alternative standard cage ¹⁾		
	dynamic C	static C_0		Reference speed	Limiting speed				Bearing with standard cage	
d	D	B								
mm			kN		r/min	kg	–			
105	225	49	500	500	57	3 200	3 800	8,6	* N 321 ECP	–
	cont. 260	60	501	570	64	2 800	3 400	17,5	NU 421 M	–
110	170	28	128	166	19,3	4 500	7 000	2,3	NU 1022 ML	M
	200	38	335	365	42,5	3 600	4 000	4,7	* NU 222 ECP	J, M, ML
	200	38	335	365	42,5	3 600	4 000	4,8	* NJ 222 ECP	J, M, ML
	200	38	335	365	42,5	3 600	4 000	5	* NUP 222 ECP	J, M, ML
	200	38	335	365	42,5	3 600	4 000	4,8	* N 222 ECP	M
	200	53	440	520	61	3 600	4 000	6,7	* NU 2222 ECP	J, ML
	200	53	440	520	61	3 600	4 000	6,7	* NJ 2222 ECP	J, ML
	200	53	440	520	61	3 600	4 000	7	* NUP 2222 ECP	J, ML
	240	50	530	540	61	3 000	3 400	10,5	* NU 322 ECP	J, M, ML
	240	50	530	540	61	3 000	3 400	10,5	* NJ 322 ECP	J, M, ML
	240	50	530	540	61	3 000	3 400	11	* NUP 322 ECP	J, M, ML
	240	50	530	540	61	3 000	3 400	10	* N 322 ECP	M
240	80	780	900	102	3 000	3 400	17	* NU 2322 ECP	ML	
240	80	780	900	102	3 000	3 400	17	* NJ 2322 ECP	ML	
240	80	780	900	102	3 000	3 400	17,5	* NUP 2322 ECP	ML	
280	65	523	585	64	2 600	3 200	20,5	NU 422	–	
280	65	523	585	64	2 600	3 200	20,5	NJ 422	–	
120	180	28	134	183	20,8	4 000	6 300	2,55	NU 1024 ML	M
	215	40	390	430	49	3 400	3 600	5,6	* NU 224 ECP	J, M, ML
	215	40	390	430	49	3 400	3 600	5,85	* NJ 224 ECP	J, M, ML
	215	40	390	430	49	3 400	3 600	5,95	* NUP 224 ECJ	J, M, ML
	215	40	390	430	49	3 400	3 600	5,75	* N 224 ECP	M
	215	58	520	630	72	3 400	3 600	8,3	* NU 2224 ECP	J, M, ML
	215	58	520	630	72	3 400	3 600	8,5	* NJ 2224 ECP	J, M, ML
215	58	520	630	72	3 400	3 600	8,65	* NUP 2224 ECP	J, M, ML	

¹⁾ When ordering bearings with an alternative standard cage the suffix of the standard cage has to be replaced by the suffix of the alternative cage. For example NU .. ECP becomes NU .. ECML (for permissible speed → page 600).

* SKF Explorer bearing

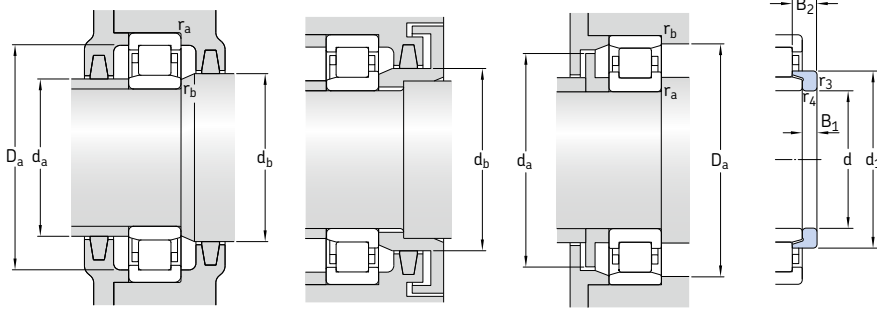

Angle ring

Dimensions							Abutment and fillet dimensions					Calculation factor k_r	Angle ring Designation	Mass	Dimensions		
d	d ₁	D ₁	F, E	r _{1,2} min.	r _{3,4} min.	s ¹⁾	d _a min.	d _a max.	d _b , D _a min.	D _a max.	r _a max.				r _b max.	B ₁	B ₂
mm																	
105	145	-	201	3	3	3,4	119	198	205	210	2,5	2,5	0,12	-			
cont.	-	203	144,5	4	4	4,9	124	140	147	241	3	3	0,15	-			
110	-	149	125	2	1,1	3,8	116	122	128	160	2	1	0,15	-			
	141	174	132,5	2,1	2,1	2,1	122	129	135	187	2	2	0,15	HJ 222 EC	0,62	11	17
	141	174	132,5	2,1	2,1	2,1	122	129	144	187	2	2	0,15	HJ 222 EC	0,62	11	17
	141	174	132,5	2,1	2,1	-	122	-	144	187	2	2	0,15	-			
	141	-	180,5	2,1	2,1	2,1	122	177	184	188	2	2	0,12	-			
	-	174	132,5	2,1	2,1	3,7	122	129	135	187	2	2	0,2	-			
	141	174	132,5	2,1	2,1	3,7	122	129	144	187	2	2	0,2	-			
	141	174	132,5	2,1	2,1	-	122	-	144	187	2	2	0,2	-			
	155	201	143	3	3	3	124	139	146	225	2,5	2,5	0,15	HJ 322 EC	1,2	14	22
	155	201	143	3	3	3	124	139	159	225	2,5	2,5	0,15	HJ 322 EC	1,2	14	22
	155	201	143	3	3	-	124	-	159	225	2,5	2,5	0,15	-			
	155	-	211	3	3	3	124	208	215	225	2,5	2,5	0,12	-			
	155	201	143	3	3	7,5	124	139	146	225	2,5	2,5	0,25	HJ 2322 EC	1,25	14	26,5
	155	201	143	3	3	7,5	124	139	159	225	2,5	2,5	0,25	HJ 2322 EC	1,25	14	26,5
	155	201	143	3	3	-	124	-	159	225	2,5	2,5	0,25	-			
	-	217	155	4	4	4,8	131	151	158	260	3	3	0,15	HJ 422	2,1	17	29,5
	171	217	155	4	4	4,8	131	151	175	260	3	3	0,15	HJ 422	2,1	17	29,5
120	-	159	135	2	1,1	3,8	126	132	138	171	2	1	0,15	-			
	153	188	143,5	2,1	2,1	1,9	132	140	146	201	2	2	0,15	HJ 224 EC	0,71	11	17
	153	188	143,5	2,1	2,1	1,9	132	140	156	201	2	2	0,15	HJ 224 EC	0,71	11	17
	153	188	143,5	2,1	2,1	-	132	-	156	201	2	2	0,15	-			
	153	-	195,5	2,1	2,1	1,9	132	192	199	203	2	2	0,12	-			
	153	188	143,5	2,1	2,1	3,8	132	140	146	201	2	2	0,2	HJ 2224 EC	0,73	11	20
	153	188	143,5	2,1	2,1	3,8	132	140	156	201	2	2	0,2	HJ 2224 EC	0,73	11	20
	153	188	143,5	2,1	2,1	-	132	-	156	201	2	2	0,2	-			

¹⁾ Permissible axial displacement from the normal position of one bearing ring relative to the other.

5.1 Single row cylindrical roller bearings d 120 – 140 mm

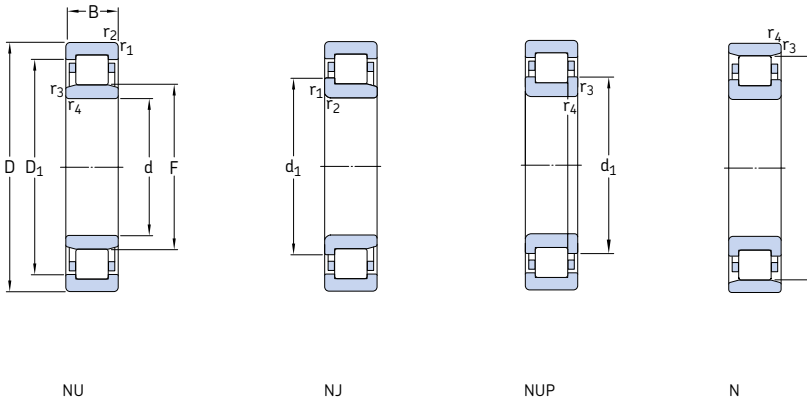

Principal dimensions			Basic load ratings		Fatigue load limit P_u	Speed ratings		Mass	Designations Bearing with standard cage	Alternative standard cage ¹⁾	
d	D	B	dynamic C	static C_0		Reference speed	Limiting speed				
mm			kN		kN	r/min		kg	-		
120 cont.	260	55	610	620	69,5	2 800	3 200	13	* NU 324 ECP	J, M, ML, PH	
	260	55	610	620	69,5	2 800	3 200	13,5	* NJ 324 ECP	J, M, ML, PH	
	260	55	610	620	69,5	2 800	3 200	13,5	* NUP 324 ECP	J, M, ML, PH	
	260	55	610	620	69,5	2 800	3 200	13	* N 324 ECP	M	
	260	86	915	1 040	116	2 800	5 000	23	* NU 2324 ECML	M	
	260	86	915	1 040	116	2 800	5 000	23	* NJ 2324 ECML	M	
	260	86	915	1 040	116	2 800	5 000	23,5	* NUP 2324 ECML	M	
	310	72	644	735	78	2 400	2 800	27,5	NU 424	M	
	130	200	33	165	224	25	3 800	5 600	3,85	NU 1026 ML	M
		200	33	165	224	25	3 800	5 600	3,9	NJ 1026 ML	M
		230	40	415	455	51	3 200	3 400	6,45	* NU 226 ECP	J, M, ML
		230	40	415	455	51	3 200	3 400	6,6	* NJ 226 ECP	J, M, ML
230		40	415	455	51	3 200	3 400	6,7	* NUP 226 ECP	J, M, ML	
230		40	415	455	51	3 200	3 400	6,45	* N 226 ECP	-	
230		64	610	735	83	3 200	3 400	10	* NU 2226 ECP	ML	
230		64	610	735	83	3 200	3 400	10,5	* NJ 2226 ECP	ML	
230		64	610	735	83	3 200	3 400	11	* NUP 2226 ECP	ML	
280		58	720	750	81,5	2 400	3 000	16	* NU 326 ECP	J, M, ML	
280		58	720	750	81,5	2 400	3 000	17	* NJ 326 ECP	J, M, ML	
280		58	720	750	81,5	2 400	3 000	19,5	* NUP 326 ECP	J, M, ML	
280	58	720	750	81,5	2 400	3 000	16,5	* N 326 ECP	M		
280	93	1 060	1 250	137	2 400	4 600	28,5	* NU 2326 ECML	PA		
280	93	1 060	1 250	137	2 400	4 500	29,5	* NJ 2326 ECML	PA		
280	93	1 060	1 250	137	2 400	4 500	29,5	* NUP 2326 ECML	PA		
140	210	33	179	255	28	3 600	5 300	4,05	NU 1028 ML	M	
	250	42	450	510	57	2 800	3 200	9,4	* NU 228 ECM	J, ML	
	250	42	450	510	57	2 800	3 200	9,55	* NJ 228 ECM	J, ML	
	250	42	450	510	57	2 800	3 200	9,3	* NUP 228 ECM	J, ML	
	250	68	655	830	93	2 800	4 800	15	* NU 2228 ECML	PA	

¹⁾ When ordering bearings with an alternative standard cage the suffix of the standard cage has to be replaced by the suffix of the alternative cage. For example NU .. ECP becomes NU .. ECML (for permissible speed → page 600).

* SKF Explorer bearing

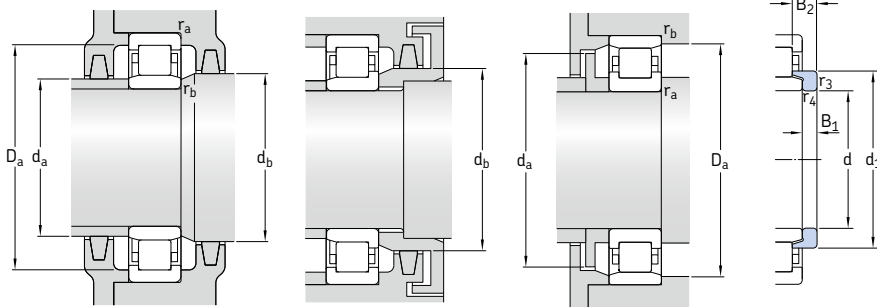

Angle ring

Dimensions				Abutment and fillet dimensions							Calculation factor k_r	Angle ring Designation	Mass	Dimensions				
d	d ₁	D ₁	F, E	r _{1,2}	r _{3,4}	s ¹⁾	d _a min.	d _a max.	d _b , D _a min.	D _a max.				r _a max.	r _b max.	B ₁	B ₂	
mm																		
120 cont.	168	219	154	3	3	3,7	134	150	157	244	2,5	2,5	0,15	HJ 324 EC	1,4	14	22,5	
	168	219	154	3	3	3,7	134	150	171	244	2,5	2,5	0,15	HJ 324 EC	1,4	14	22,5	
	168	219	154	3	3	-	134	-	171	244	2,5	2,5	0,15	-	-	-	-	
	168	-	230	3	3	3,7	134	226	235	245	2,5	2,5	0,12	-	-	-	-	
	168	219	154	3	3	7,2	134	150	157	244	2,5	2,5	0,38	HJ 2324 EC	1,45	14	26	
	168	219	154	3	3	7,2	134	150	171	244	2,5	2,5	0,38	HJ 2324 EC	1,45	14	26	
	168	219	154	3	3	-	134	-	171	244	2,5	2,5	0,38	-	-	-	-	
	188	240	170	5	5	6,3	144	165	173	286	4	4	0,15	HJ 424	2,6	17	30,5	
	130	-	175	148	2	1,1	4,7	137	145	151	191	2	1	0,15	-	-	-	-
		154	175	148	2	1,1	4,7	137	145	158	191	2	1	0,15	-	-	-	-
164		202	153,5	3	3	2,1	144	150	157	215	2,5	2,5	0,15	HJ 226 EC	0,75	11	17	
164		202	153,5	3	3	2,1	144	150	167	215	2,5	2,5	0,15	HJ 226 EC	0,75	11	17	
164		202	153,5	3	3	-	144	-	167	215	2,5	2,5	0,15	-	-	-	-	
164		-	209,5	3	3	2,1	144	206	213	217	2,5	2,5	0,12	-	-	-	-	
164		202	153,5	3	3	4,3	144	150	157	215	2,5	2,5	0,2	HJ 2226 EC	0,83	11	21	
164		202	153,5	3	3	4,3	144	150	167	215	2,5	2,5	0,2	HJ 2226 EC	0,83	11	21	
164		202	153,5	3	3	-	144	-	167	215	2,5	2,5	0,2	-	-	-	-	
181		236	167	4	4	3,7	147	163	170	261	3	3	0,15	HJ 326 EC	1,65	14	23	
181	236	167	4	4	3,7	147	163	184	261	3	3	0,15	HJ 326 EC	1,65	14	23		
181	236	167	4	4	-	147	-	184	261	3	3	0,15	-	-	-	-		
181	-	247	4	4	3,7	147	243	251	262	3	3	0,12	-	-	-	-		
181	236	167	4	4	8,7	147	163	170	261	3	3	0,38	HJ 2326 EC	1,6	14	28		
181	236	167	4	4	8,7	147	163	184	261	3	3	0,38	HJ 2326 EC	1,6	14	28		
181	236	167	4	4	-	147	-	184	261	3	3	0,38	-	-	-	-		
140	-	185	158	2	1,1	4,4	147	155	161	201	2	1	0,15	-	-	-	-	
	179	217	169	3	3	2,5	154	165	172	235	2,5	2,5	0,15	HJ 228 EC	0,97	11	18	
	179	217	169	3	3	2,5	154	165	182	235	2,5	2,5	0,15	HJ 228 EC	0,97	11	18	
	179	217	169	3	3	-	154	-	182	235	2,5	2,5	0,15	-	-	-	-	
	179	217	169	3	3	4,4	154	165	172	235	2,5	2,5	0,3	HJ 2228 EC	1,05	11	23	

¹⁾ Permissible axial displacement from the normal position of one bearing ring relative to the other.

5.1 Single row cylindrical roller bearings d 140 – 170 mm

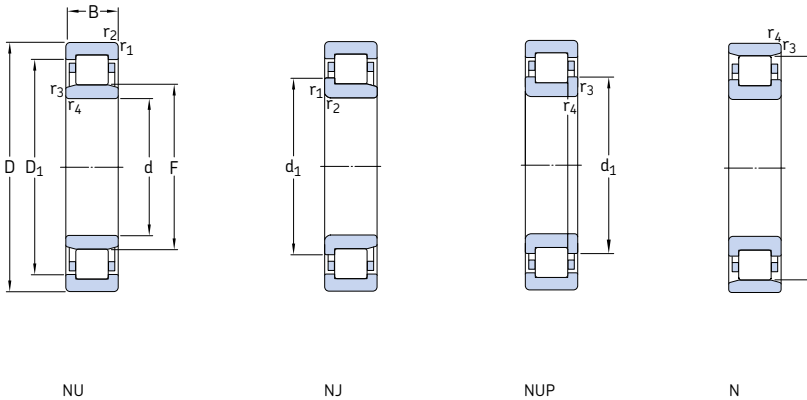

Principal dimensions			Basic load ratings		Fatigue load limit P_u	Speed ratings		Mass	Designations Bearing with standard cage	Alternative standard cage ¹⁾	
d	D	B	dynamic C	static C_0		Reference speed	Limiting speed				
mm			kN		kN	r/min	kg	-			
140	250	68	655	830	93	2 800	4 800	15,5	* NJ 2228 ECML	PA	
	cont.	250	68	655	830	93	2 800	4 800	15,5	* NUP 2228 ECML	PA
		300	62	780	830	88	2 400	2 800	22	* NU 328 ECM	J, ML
		300	62	780	830	88	2 400	2 800	23	* NJ 328 ECM	J, ML
		300	62	780	830	88	2 400	2 800	23,5	* NUP 328 ECM	J, ML
		300	102	1 200	1 430	150	2 400	4 300	36	* NU 2328 ECML	-
		300	102	1 200	1 430	150	2 400	4 300	36,5	* NJ 2328 ECML	-
		300	102	1 200	1 430	150	2 400	4 300	37	* NUP 2328 ECML	-
	150	225	35	198	290	31,5	3 200	5 000	4,9	NU 1030 ML	M
		270	45	510	600	64	2 600	2 800	11,5	* NU 230 ECM	J, ML
270		45	510	600	64	2 600	2 800	12	* NJ 230 ECM	J, ML	
270		45	510	600	64	2 600	2 800	12	* NUP 230 ECM	J, ML	
270		73	735	930	100	2 600	2 800	18,5	* NU 2230 ECM	ML	
270		73	735	930	100	2 600	2 800	19	* NJ 2230 ECM	ML	
		320	65	900	965	100	2 200	4 000	26	* NU 330 ECML	M
		320	65	900	965	100	2 200	4 000	26,5	* NJ 330 ECML	M
		320	108	1 370	1 630	170	2 200	4 000	43	* NU 2330 ECML	-
		320	108	1 370	1 630	170	2 200	4 000	43,5	* NJ 2330 ECML	-
160	240	38	229	325	35,5	3 000	4 800	6	NU 1032 ML	M	
	290	48	585	680	72	2 400	2 600	14	* NU 232 ECM	ML	
	290	48	585	680	72	2 400	2 600	14,5	* NJ 232 ECM	ML	
	290	48	585	680	72	2 400	2 600	15,5	* NUP 232 ECM	ML	
	290	48	585	680	72	2 400	2 600	15	* N 232 ECM	-	
	290	80	930	1 200	129	2 400	4 000	23,5	* NU 2232 ECML	M	
	290	80	930	1 200	129	2 400	4 000	24	* NJ 2232 ECML	M	
		340	68	1 000	1 080	112	2 000	3 600	31	* NU 332 ECML	M
		340	68	1 000	1 080	112	2 000	3 600	31,5	* NJ 332 ECML	M
		340	114	1 250	1 730	173	1 800	3 600	50,5	NU 2332 ECML	-
	340	114	1 250	1 730	173	1 800	3 600	51,5	NJ 2332 ECML	-	
170	260	42	275	400	41,5	2 800	4 300	8	NU 1034 ML	M	
	260	42	275	400	41,5	2 800	4 300	8,2	NJ 1034 ML	M	

¹⁾ When ordering bearings with an alternative standard cage the suffix of the standard cage has to be replaced by the suffix of the alternative cage. For example NU .. ML becomes NU .. M (for permissible speed → page 600).

* SKF Explorer bearing

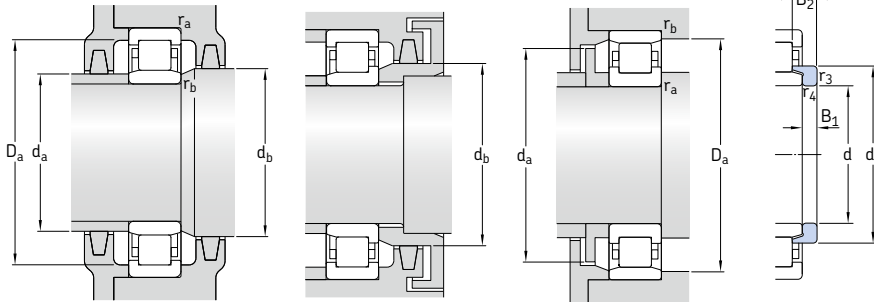

Angle ring

Dimensions				Abutment and fillet dimensions							Calculation factor		Angle ring Designation	Mass	Dimensions			
d	d ₁	D ₁	F, E	r _{1,2}	r _{3,4}	s ¹⁾	d _a min.	d _a max.	d _b , D _a min.	D _a max.	r _a max.	r _b max.	k _r		kg	B ₁	B ₂	
mm																		
140	179	217	169	3	3	4,4	154	165	182	235	2,5	2,5	0,3	HJ 2228 EC	1,05	11	23	
	cont.	179	169	3	3	-	154	-	182	235	2,5	2,5	0,3	-				
	195	252	180	4	3	3,7	157	175	183	282	3	3	0,15	HJ 328 EC	2,05	15	25	
	195	252	180	4	4	-	157	-	199	282	3	3	0,15	HJ 328 EC	2,05	15	25	
	195	252	180	4	4	-	157	-	199	282	3	3	0,15	-				
	195	252	180	4	4	9,7	157	175	183	282	3	3	0,38	HJ 2328 EC	2,15	15	31	
	195	252	180	4	4	9,7	157	175	199	282	3	3	0,38	HJ 2328 EC	2,15	15	31	
	195	252	180	4	4	-	157	-	199	282	3	3	0,38	-				
150	-	198	169,5	2,1	1,5	4,9	158	167	173	215	2	1,5	0,15	-				
	193	234	182	3	3	2,5	164	178	186	254	2,5	2,5	0,15	HJ 230 EC	1,25	12	19,5	
	193	234	182	3	3	2,5	164	178	196	254	2,5	2,5	0,15	HJ 230 EC	1,25	12	19,5	
	193	234	182	3	3	-	164	-	196	254	2,5	2,5	0,15	-				
	194	234	182	3	3	4,9	164	178	186	254	2,5	2,5	0,2	HJ 2230 EC	1,35	12	24,5	
	194	234	182	3	3	4,9	164	178	197	254	2,5	2,5	0,2	HJ 2230 EC	1,35	12	24,5	
	209	270	193	4	3	4	167	188	196	302	3	3	0,23	HJ 330 EC	2,3	15	25	
	209	270	193	4	4	4	167	188	213	302	3	3	0,23	HJ 330 EC	2,3	15	25	
	209	270	193	4	4	10,5	167	188	196	302	3	3	0,38	-				
	209	270	193	4	4	10,5	167	188	213	302	3	3	0,38	-				
160	188	211	180	2,1	1,5	5,2	168	177	184	230	2	1,5	0,15	HJ 1032	0,72	10	19	
	206	250	195	3	3	2,7	175	191	198	274	2,5	2,5	0,15	HJ 232 EC	1,5	12	20	
	206	250	195	3	3	2,7	175	191	210	274	2,5	2,5	0,15	HJ 232 EC	1,5	12	20	
	206	250	195	3	3	-	175	-	210	274	2,5	2,5	0,15	-				
	206	-	259	3	3	2,7	175	255	263	275	2,5	2,5	0,12	-				
	205	252	193	3	3	4,5	174	189	196	274	2,5	2,5	0,3	HJ 2232 EC	1,55	12	24,5	
	205	252	193	3	3	4,5	174	189	209	274	2,5	2,5	0,3	HJ 2232 EC	1,55	12	24,5	
	221	286	204	4	4	4	177	199	207	321	3	3	0,23	HJ 332 EC	2,6	15	25	
	221	286	204	4	4	4	177	199	225	321	3	3	0,23	HJ 332 EC	2,6	15	25	
	-	286	204	4	4	11	177	199	207	321	3	3	0,38	-				
	221	286	204	4	4	11	177	199	225	321	3	3	0,38	-				
	170	201	227	193	2,1	2,1	5,8	180	189	197	250	2	2	0,15	HJ 1034	0,93	11	21
		201	227	193	2,1	2,1	5,8	180	189	206	250	2	2	0,15	HJ 1034	0,93	11	21

¹⁾ Permissible axial displacement from the normal position of one bearing ring relative to the other.

5.1 Single row cylindrical roller bearings d 170 – 200 mm

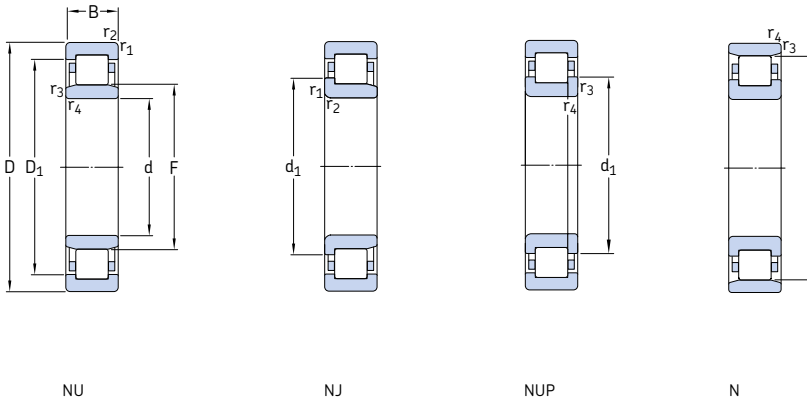

Principal dimensions	Basic load ratings		Fatigue load limit P_u	Speed ratings		Mass	Designations	Alternative standard cage ¹⁾			
	dynamic	static C_0		Reference speed	Limiting speed				Bearing with standard cage		
d	D	B	C								
mm			kN	kN	r/min	kg	–				
170 cont.	310	52	695	815	85	2 200	3 800	17,5	* NU 234 ECML	M	
	310	52	695	815	85	2 200	3 800	18	* NJ 234 ECML	M	
	310	86	1 060	1 340	140	2 200	3 800	28,5	* NU 2234 ECML	–	
	310	86	1 060	1 340	140	2 200	3 800	29	* NJ 2234 ECML	–	
	360	72	952	1 180	116	1 700	2 200	37,5	NU 334 ECM	–	
	360	72	952	1 180	116	1 700	2 200	37	N 334 ECM	–	
	360	120	1 450	2 040	204	1 700	3 400	60,5	NU 2334 ECML	–	
	360	120	1 450	2 040	204	1 700	3 400	61,5	NJ 2334 ECML	–	
	180	280	46	336	475	51	2 600	4 000	10,5	NU 1036 ML	M
		320	52	720	850	88	2 200	3 600	18,5	* NU 236 ECML	M
320		52	720	850	88	2 200	3 600	19	* NJ 236 ECML	M	
320		86	1 100	1 430	146	2 200	3 600	30	* NU 2236 ECML	M	
320		86	1 100	1 430	146	2 200	3 600	30,5	* NJ 2236 ECML	M	
380		75	1 020	1 290	125	1 600	2 200	44,5	NU 336 ECM	–	
380		75	1 020	1 290	125	1 600	2 200	44	NJ 336 ECM	–	
380		126	1 610	2 240	216	1 600	3 200	69,5	NU 2336 ECML	–	
380		126	1 610	2 240	216	1 600	3 200	70,5	NJ 2336 ECML	–	
190		290	46	347	500	53	2 600	3 800	11	NU 1038 ML	M
	290	46	347	500	53	2 600	3 800	11,5	NJ 1038 ML	M	
	340	55	800	965	98	2 000	3 400	22,5	* NU 238 ECML	M	
	340	55	800	965	98	2 000	3 400	23	* NJ 238 ECML	M	
	340	55	800	965	98	2 000	3 400	23,5	* NUP 238 ECML	M	
	340	92	1 220	1 600	160	2 000	3 400	37	* NU 2238 ECML	M	
	400	78	1 140	1 500	143	1 500	2 000	50	NU 338 ECM	–	
	400	132	1 830	2 550	236	1 500	3 100	80,5	NU 2338 ECML	–	
	200	310	51	380	570	58,5	2 400	3 500	14	NU 1040 ML	M
		360	58	880	1 060	106	1 900	3 200	26,5	* NU 240 ECML	M
360		58	880	1 060	106	1 900	3 200	26	* NJ 240 ECML	M	
360		98	1 370	1 800	180	1 900	3 200	44	* NU 2240 ECML	–	
360		98	1 370	1 800	180	1 900	3 200	44,5	* NJ 2240 ECML	–	

¹⁾ When ordering bearings with an alternative standard cage the suffix of the standard cage has to be replaced by the suffix of the alternative cage. For example NU ..ML becomes NU .. M (for permissible speed → page 600).

* SKF Explorer bearing

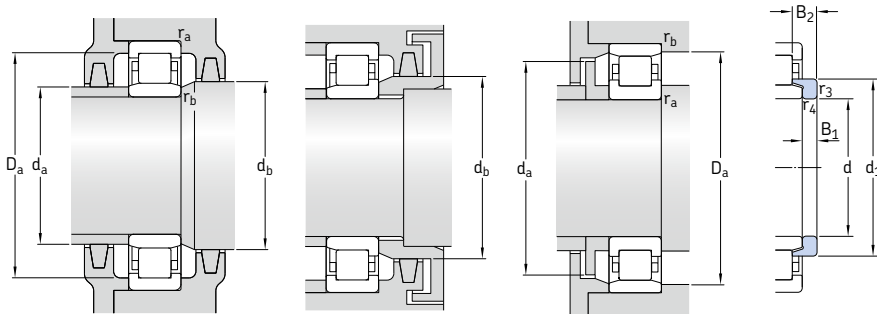

Angle ring

Dimensions				Abutment and fillet dimensions						Calculation factor		Angle ring Designation	Mass	Dimensions			
d	d ₁	D ₁	F, E	r _{1,2}	r _{3,4}	s ¹⁾	d _a min.	d _a max.	d _b , D _a min.	D _a max.	r _a max.	r _b max.	k _r		kg	B ₁	B ₂
mm																	
170 cont.	220	268	207	4	4	2,9	188	203	210	292	3	3	0,23	HJ 234 EC	1,65	12	20
	220	268	207	4	4	2,9	188	203	224	292	3	3	0,23	HJ 234 EC	1,65	12	20
	220	270	205	4	4	4,2	187	201	208	292	3	3	0,3	HJ 2234 EC	1,8	12	24
	220	270	205	4	4	4,2	187	201	226	292	3	3	0,3	HJ 2234 EC	1,8	12	24
	-	303	218	4	3	4,6	187	213	221	341	3	3	0,15	-	-	-	-
	236	-	318	4	4	4,6	187	313	323	342	3	3	0,12	-	-	-	-
180	-	301	216	4	4	10	186	211	219	341	3	3	0,38	-	-	-	-
	234	301	216	4	4	10	186	211	238	341	3	3	0,38	-	-	-	-
	215	244	205	2,1	2,1	6,1	190	202	209	270	2	2	0,15	HJ 1036	1,25	12	22,5
	230	279	217	4	4	2,9	198	213	220	302	3	3	0,23	HJ 236 EC	1,7	12	20
	230	279	217	4	4	2,9	198	213	234	302	3	3	0,23	HJ 236 EC	1,7	12	20
	229	280	215	4	4	4,2	197	211	218	302	3	3	0,3	HJ 2236 EC	1,9	12	24
	229	280	215	4	4	4,2	197	211	233	302	3	3	0,3	HJ 2236 EC	1,9	12	24
	-	319	231	4	3	4,2	197	226	234	361	3	3	0,15	-	-	-	-
	250	319	231	4	4	4,2	197	226	254,5	361	3	3	0,15	-	-	-	-
	-	320	227	4	4	10,5	196	222	230	361	3	3	0,38	-	-	-	-
248	320	227	4	4	10,5	196	222	252	361	3	3	0,38	-	-	-	-	
190	225	254	215	2,1	2,1	6,1	200	212	219	280	2	2	0,15	HJ 1038	1,35	12	22,5
	225	254	215	2,1	2,1	6,1	200	212	231	280	2	2	0,15	HJ 1038	1,35	12	22,5
	244	295	230	4	4	3	207	226	233	321	3	3	0,23	HJ 238 EC	2,2	13	21,5
	244	295	230	4	4	3	207	226	248	321	3	3	0,23	HJ 238 EC	2,2	13	21,5
	244	295	230	4	4	-	207	-	248	321	3	3	0,23	-	-	-	-
	-	297	228	4	4	5	207	224	231	321	3	3	0,3	-	-	-	-
	264	338	245	5	5	4,3	210	240	249	380	4	4	0,15	HJ 338 EC	4,3	18	29
	-	341	240	5	5	9,5	209	234	244	380	4	4	0,38	-	-	-	-
200	239	269	229	2,1	2,1	7	211	225	234	300	2	2	0,15	HJ 1040	1,65	13	25,5
	258	312	243	4	4	2,6	217	238	247	341	3	3	0,23	HJ 240 EC	2,55	14	23
	258	312	243	4	4	2,6	217	238	262	341	3	3	0,23	HJ 240 EC	2,55	14	23
	-	313	241	4	4	5,1	217	236	245	341	3	3	0,3	-	-	-	-
	-	313	241	4	4	5,1	217	236	245	341	3	3	0,3	-	-	-	-
	256	313	241	4	4	5,1	217	236	260	342	3	3	0,3	-	-	-	-

¹⁾ Permissible axial displacement from the normal position of one bearing ring relative to the other.

5.1 Single row cylindrical roller bearings d 200 – 260 mm

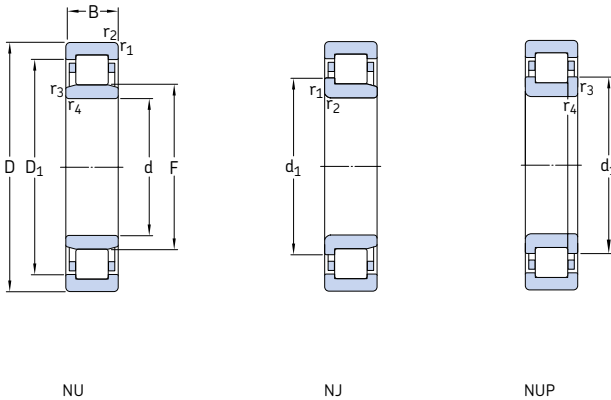

Principal dimensions	Basic load ratings		Fatigue load limit P_u	Speed ratings		Mass	Designations Bearing with standard cage	Alternative standard cage ¹⁾			
	dynamic C	static C_0		Reference speed	Limiting speed						
d	D	B									
mm			kN		r/min	kg	–				
200 cont.	420	80	1 230	1 630	150	1 400	2 800	57	NJ 340 ECML	–	
	420	80	1 230	1 630	150	1 400	2 800	56,5	NJ 340 ECML	–	
	420	138	1 980	2 800	255	1 400	2 800	92,5	NU 2340 ECML	–	
	420	138	1 980	2 800	255	1 400	2 800	97	NJ 2340 ECML	–	
220	340	56	495	735	73,5	2 200	3 200	19	NJ 1044 ML	M	
	400	65	1 060	1 290	125	1 700	3 000	37	* NU 244 ECML	M	
	400	65	1 060	1 290	125	1 700	3 000	37,5	* NJ 244 ECML	M	
	400	65	1 060	1 290	125	1 700	3 000	38	* NUP 244 ECML	M	
	400	108	1 570	2 280	212	1 600	3 000	59	NU 2244 ECML	–	
	400	108	1 570	2 280	212	1 600	3 000	60	NJ 2244 ECML	–	
	460	88	1 210	1 630	150	1 500	1 700	72,5	NU 344 M	–	
	460	88	1 210	1 630	150	1 500	1 700	73,5	NJ 344 M	–	
	460	145	2 380	3 450	310	1 300	2 200	124	NU 2344 ECMA	–	
	240	360	56	523	800	78	2 000	3 000	19,5	NU 1048 ML	M
		440	72	952	1 370	129	1 600	2 200	51,5	NU 248 MA	–
		440	72	952	1 370	129	1 600	2 200	53	NJ 248 MA	–
440		72	952	1 370	129	1 600	2 200	53,5	NUP 248 MA	–	
440		120	1 450	2 360	224	1 500	2 200	84	NU 2248 MA	–	
440		120	1 450	2 360	224	1 500	2 200	85	NJ 2248 MA	–	
500		95	1 450	2 000	180	1 300	1 600	94,5	NU 348 M	–	
500		95	1 450	2 000	180	1 300	2 000	98,5	NJ 348 M	–	
500		155	2 600	3 650	320	1 200	2 000	155	NU 2348 ECMA	–	
260		400	65	627	965	96,5	1 800	2 800	29,5	NU 1052 ML	M
		400	65	627	965	96,5	1 800	2 800	30	NJ 1052 ML	M
		480	80	1 170	1 700	150	1 400	2 000	68,5	NU 252 MA	–
	480	80	1 170	1 700	150	1 400	2 000	69	NJ 252 MA	–	
	480	80	1 170	1 700	156	1 400	2 000	72	NUP 252 MA	–	
	480	130	1 790	3 000	265	1 300	2 000	110	NU 2252 MA	–	
	480	130	1 790	3 000	275	1 300	2 000	112	NJ 2252 MA	–	
	540	102	1 940	2 700	236	1 100	1 800	125	NU 352 ECMA	–	

¹⁾ When ordering bearings with an alternative standard cage the suffix of the standard cage has to be replaced by the suffix of the alternative cage. For example NU .. ML becomes NU .. M (for permissible speed → page 600).

* SKF Explorer bearing

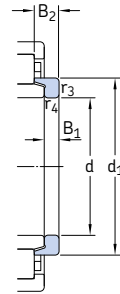
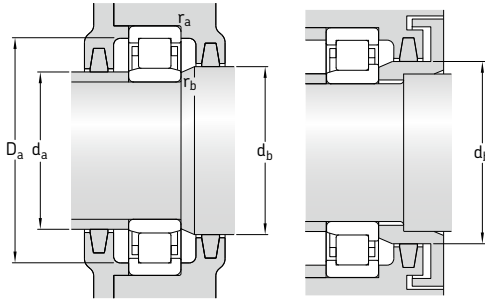

Angle ring

Dimensions				Abutment and fillet dimensions						Calculation factor		Angle ring Designation	Mass	Dimensions			
d	d ₁	D ₁	F	r _{1,2}	r _{3,4}	s ¹⁾	d _a min.	d _a max.	d _b , D _a min.	D _a max.	r _a max.	r _b max.	k _r		kg	B ₁	B ₂
mm																	
200	–	353	258	5	5	6	220	253	262	399	4	4	0,23	–			
cont.	278	353	258	5	5	6	220	253	282	400	4	4	0,23	–			
	–	353	253	5	5	9,4	220	247	257	399	4	4	0,38	–			
	278	353	253	5	5	9,4	220	247	282	399	4	4	0,38	–			
220	262	297	250	3	3	7,5	233	246	266	328	2,5	2,5	0,15	HJ 1044	2,15	14	27
	284	344	268	4	4	2,3	238	263	272	383	3	3	0,23	HJ 244 EC	3,25	15	25
	284	344	268	4	4	2,3	238	263	288	383	3	3	0,23	HJ 244 EC	3,25	15	25
	284	344	268	4	4	–	238	–	288	383	3	3	0,23	–			
	–	349	259	4	4	7,9	237	254	263	383	3	3	0,3	–			
	278	349	259	4	4	7,9	237	254	282	383	3	3	0,3	–			
	–	371	284	5	5	5,2	240	277	288	440	4	4	0,15	–			
	307	371	284	5	5	5,2	240	277	311	440	4	4	0,15	–			
	–	384	277	5	5	10,4	240	268	280	440	4	4	0,25	–			
240	282	317	270	3	3	7,5	252	266	274	348	2,5	2,5	0,15	HJ 1048	2,25	14	27
	–	365	295	4	4	3,4	257	288	299	423	3	3	0,15	–			
	313	365	295	4	4	3,4	257	288	317	423	3	3	0,15	–			
	313	365	295	4	4	–	257	–	317	423	3	3	0,15	–			
	–	365	295	4	4	4,3	257	284	299	423	3	3	0,2	–			
	313	365	295	4	4	4,3	257	284	317	423	3	3	0,2	–			
	–	403	310	5	5	5,6	260	302	314	480	4	4	0,15	HJ 348	8,9	22	39,5
	335	403	310	5	5	5,6	260	302	339	480	4	4	0,15	HJ 348	8,9	22	39,5
	–	403	299	5	5	6,4	260	293	305	480	4	4	0,25	–			
260	309	349	296	4	4	8	275	292	300	385	3	3	0,15	HJ 1052	3,4	16	31,5
	309	349	296	4	4	8	275	292	313	385	3	3	0,15	HJ 1052	3,4	16	31,5
	–	397	320	5	5	3,4	280	313	324	460	4	4	0,15	HJ 252	6,2	18	33
	340	397	320	5	5	3,4	280	313	344	460	4	4	0,15	HJ 252	6,2	18	33
	340	397	320	5	5	–	280	–	344	460	4	4	0,15	–			
	–	397	320	5	5	4,3	280	309	324	460	4	4	0,2	–			
	340	397	320	5	5	4,3	280	309	344	460	4	4	0,2	–			
	–	455	337	6	6	4,2	286	330	341	514	5	5	0,15	–			

¹⁾ Permissible axial displacement from the normal position of one bearing ring relative to the other.

5.1 Single row cylindrical roller bearings d 280 – 480 mm

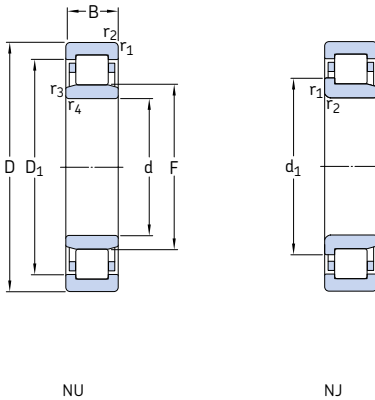

Principal dimensions			Basic load ratings		Fatigue load limit P_u	Speed ratings		Mass	Designations Bearing with standard cage	Alternative standard cage ¹⁾
d	D	B	dynamic C	static C_0		Reference speed	Limiting speed			
mm			kN		kN	r/min		kg	–	
280	420	65	660	1 060	102	1 700	2 600	31	NU 1056 ML	M
	500	80	1 190	1 800	156	1 400	1 900	71,5	NJ 256 MA	–
	500	80	1 140	1 700	153	1 400	1 900	73	NJ 256 MA	–
	500	130	2 200	3 450	305	1 200	1 900	115	NU 2256 ECMA	–
	580	175	2 700	4 300	365	1 000	1 700	232	NU 2356 MA	–
300	460	74	858	1 370	129	1 500	2 000	46,5	NU 1060 MA	–
	460	74	858	1 370	129	1 500	2 000	47	NJ 1060 MA	–
	540	85	1 420	2 120	183	1 300	1 800	88	NU 260 MA	–
	540	140	2 090	3 450	300	1 200	1 800	145	NU 2260 MA	–
320	480	74	880	1 430	132	1 400	1 900	48,5	NU 1064 MA	–
	480	74	880	1 430	132	1 400	1 900	48	NJ 1064 MA	–
	580	92	1 610	2 450	204	1 200	1 600	115	NU 264 MA	–
	580	150	3 190	5 000	415	1 000	1 600	180	NU 2264 ECMA	–
340	520	82	1 080	1 760	156	1 300	1 700	65	NU 1068 MA	–
	520	82	1 080	1 760	156	1 300	1 700	68	NJ 1068 MA	–
	620	165	2 640	4 500	365	1 000	1 500	220	NU 2268 MA	–
360	540	82	1 100	1 830	163	1 300	1 600	67,5	NU 1072 MA	–
	650	170	2 920	4 900	400	950	1 400	250	NU 2272 MA	–
380	560	82	1 140	1 930	170	1 200	1 600	70	NU 1076 MA	–
	560	82	1 140	1 930	170	1 200	1 600	71	NJ 1076 MA	–
	680	175	3 960	6 400	510	850	1 300	275	NU 2276 ECMA	–
400	600	90	1 380	2 320	196	1 100	1 500	91	NU 1080 MA	–
420	620	90	1 420	2 450	200	1 100	1 400	94	NU 1084 MA	–
440	650	94	1 510	2 650	212	1 000	1 300	105	NU 1088 MA	–
460	680	100	1 650	2 850	224	950	1 200	125	NU 1092 MA	–
	830	165	4 180	6 800	510	750	1 100	415	NU 1292 MA	–
	830	212	5 120	8 650	655	700	1 100	530	NU 2292 MA	–
480	700	100	1 680	3 000	232	900	1 200	130	NU 1096 MA	–

¹⁾ When ordering bearings with an alternative standard cage the suffix of the standard cage has to be replaced by the suffix of the alternative cage. For example NU .. ML becomes NU .. M (for permissible speed → page 600).

* SKF Explorer bearing

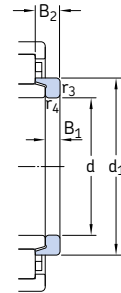
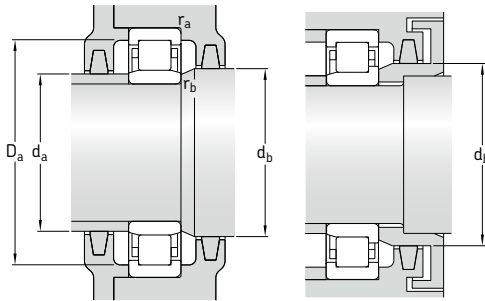

Angle ring

Dimensions				Abutment and fillet dimensions						Calculation factor k_r	Angle ring Designation	Mass	Dimensions				
d	d ₁	D ₁	F	r _{1,2} min.	r _{3,4} min.	s ¹⁾	d _a min.	d _a max.	d _b , D _a min.				D _a max.	r _a max.	r _b max.	B ₁	B ₂
mm													kg	mm			
280	329	369	316	4	4	8	295	312	321	405	3	3	0,15	HJ 1056	3,6	16	31,5
	-	417	340	5	5	3,8	300	333	344	480	4	4	0,15	-	-	-	-
	360	417	340	5	5	3,8	300	333	364	480	4	4	0,15	-	-	-	-
	-	433	333	5	5	10,2	300	320	331	480	4	4	0,2	HJ 2256 EC	6,75	18	38
-	467	362	6	6	6,6	306	347	366	554	5	5	0,25	-	-	-	-	-
300	-	402	340	4	4	9,7	317	335	344	443	3	3	0,1	HJ 1060	5,3	19	36
	356	402	340	4	4	9,7	317	335	360	443	3	3	0,1	HJ 1060	5,3	19	36
	-	451	364	5	5	4,8	320	358	368	520	4	4	0,15	-	-	-	-
	-	451	364	5	5	5,6	320	352	368	520	4	4	0,2	-	-	-	-
320	-	422	360	4	4	9,7	335	355	364	465	3	3	0,1	HJ 1064	5,65	19	36
	376	422	360	4	4	9,7	335	355	380	465	3	3	0,1	HJ 1064	5,65	19	36
	-	485	390	5	5	5,3	340	383	394	560	4	4	0,15	-	-	-	-
	-	485	380	5	5	5,9	340	377	394	560	4	4	0,2	-	-	-	-
340	-	455	385	5	5	6,5	358	380	389	502	4	4	0,1	HJ 1068	7,4	21	39,5
	403	455	385	5	5	6,5	358	380	408	502	4	4	0,1	HJ 1068	7,4	21	39,5
	-	515	416	6	6	8	366	401	421	594	5	5	0,2	-	-	-	-
	-	515	416	6	6	8	366	401	421	594	5	5	0,2	-	-	-	-
360	-	475	405	5	5	6,5	378	400	410	522	4	4	0,1	HJ 1072	7,75	21	39,5
	-	542	437	6	6	16,7	386	428	442	624	5	5	0,2	-	-	-	-
	-	495	425	5	5	10,8	398	420	430	542	4	4	0,1	HJ 1076	8,25	21	39,5
	443	495	425	5	5	10,8	398	420	448	542	4	4	0,1	HJ 1076	8,25	21	39,5
-	595	451	6	6	8,3	406	445	457	654	5	5	0,2	-	-	-	-	
400	-	527	450	5	5	14	418	446	455	582	4	4	0,1	HJ 1080	9,75	23	43
420	-	547	470	5	5	14	438	466	475	602	4	4	0,1	HJ 1084	10	23	43
440	-	574	493	6	6	14,7	463	488	498	627	5	5	0,1	HJ 1088	11,5	24	45
460	-	600	516	6	6	15,9	483	511	521	657	5	5	0,07	HJ 1092	14	25	48
	-	715	554	7,5	7,5	6,4	492	542	559	798	6	6	0,13	-	-	-	-
	-	706	554	7,5	7,5	16,5	492	542	559	798	6	6	0,2	-	-	-	-
	-	706	554	7,5	7,5	16,5	492	542	559	798	6	6	0,2	-	-	-	-
480	-	620	536	6	6	15,9	503	531	541	677	5	5	0,1	HJ 1096	14,5	25	48

¹⁾ Permissible axial displacement from the normal position of one bearing ring relative to the other.

5.1 Single row cylindrical roller bearings

d 500 – 800 mm

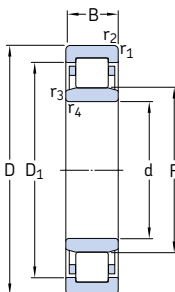

Principal dimensions			Basic load ratings		Fatigue load limit	Speed ratings		Mass	Designation
d	D	B	dynamic C	static C ₀	P _u	Reference speed	Limiting speed		
mm			kN		kN	r/min		kg	–
500	720	100	1 720	3 100	236	900	900	135	NU 10/500 MA
	920	185	5 280	8 500	620	670	950	585	NU 12/500 MA
530	780	112	2 290	4 050	305	800	1 000	190	NU 10/530 MA
	780	145	3 740	7 350	550	670	1 000	255	NU 20/530 ECMA
560	820	115	2 330	4 250	310	750	1 000	210	NU 10/560 MA
	820	150	3 800	7 650	560	630	1 000	290	NU 20/560 ECMA
	1 030	206	7 210	11 200	780	560	800	805	NU 12/560 MA
600	870	118	2 750	5 100	365	700	900	245	NU 10/600 N2MA
	870	155	4 180	8 000	570	600	900	325	NU 20/600 ECMA
	1 090	155	5 610	9 800	670	480	750	710	NU 2/600 ECMA/HB1
630	920	128	3 410	6 200	430	630	850	285	NU 10/630 ECN2MA
	920	170	4 730	9 500	670	560	850	400	NU 20/630 ECMA
	1 150	230	8 580	13 700	915	450	700	1 110	NU 12/630 ECMA/HB1
670	980	136	3 740	6 800	465	600	800	350	NU 10/670 ECMA
	980	180	5 390	11 000	750	500	800	480	NU 20/670 ECMA/HB1
710	1 030	140	4 680	8 500	570	560	750	415	NU 10/710 ECN2MA
	1 030	185	5 940	12 000	815	480	700	540	NU 20/710 ECMA/HB1
750	1 090	150	4 730	8 800	585	430	670	490	NU 10/750 ECN2MA/HB1
	1 090	195	6 270	12 700	850	430	670	635	NU 20/750 ECMA/HA1
800	1 150	200	7 040	14 600	950	400	630	715	NU 20/800 ECMA

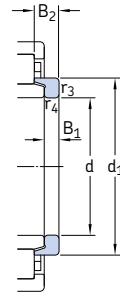
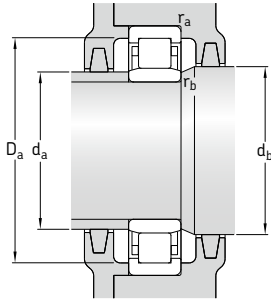

5.1

Angle ring

Dimensions						Abutment and fillet dimensions						Calculation factor k_r	Angle ring Designation	Mass	Dimensions		
d	D_1	F	$r_{1,2}$ min.	$r_{3,4}$ min.	$s^1)$	d_a min.	d_a max.	d_b, D_a min.	D_a max.	r_a max.	r_b max.				B_1	B_2	
mm													-	-	kg	mm	
500	640	556	6	6	11,2	523	550	561	697	5	5	0,1	HJ 10/500	15	25	48	
	780	603,1	7,5	7,5	13,9	532	593	610	888	6	6	0,17					-
530	692	593	6	6	10,4	553	585	598	757	5	5	0,1	-	-	-	-	
	704	591	6	6	6,8	553	587	596	757	5	5	0,14					-
560	726	625	6	6	12,3	583	617	630	797	5	5	0,1	HJ 10/560	21	27,5	53	
	741	626	6	6	6,7	583	616	631	797	5	5	0,14					-
	892	668	9,5	9,5	10,3	600	657	674	990	8	8	0,13					-
600	779	667	6	6	14	623	658	672	847	5	5	0,1	HJ 10/600	27,5	31	55	
	793	661	6	6	6,1	623	652	667	847	5	5	0,14					-
	925	749	9,5	9,5	3	640	743	755	1050	8	8	0,15					-
630	837	702	7,5	7,5	6,2	658	691	707	892	6	6	0,1	-	-	-	-	
	832	699	7,5	7,5	8,7	658	690	705	892	6	6	0,14					-
	1005	751	12	12	13,5	678	735	757	1102	10	10	0,17					-
670	891	747	7,5	7,5	7,9	698	737	753	952	6	6	0,1	-	-	-	-	
	890	746	7,5	7,5	7	698	736	752	952	6	6	0,14					-
710	939	778	7,5	7,5	17	738	769	783	1002	6	6	0,1	-	-	-	-	
	939	787	7,5	7,5	10	738	780	793	1002	6	6	0,14					-
750	993	830	7,5	7,5	12,8	778	823	838	1062	6	6	0,1	-	-	-	-	
	993	832	7,5	7,5	12,8	778	823	838	1062	6	6	0,14					-
800	1051	882	7,5	7,5	2	828	868	888	1122	6	6	0,14	-	-	-	-	

¹⁾ Permissible axial displacement from the normal position of one bearing ring relative to the other.

5.2 High-capacity cylindrical roller bearings d 100 – 170 mm

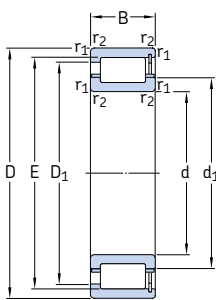

NCF..ECJB

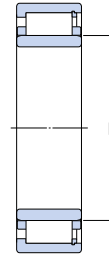
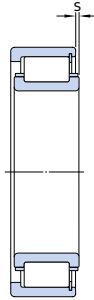

NUH..ECMH

Principal dimensions			Basic load ratings dynamic static		Fatigue load limit	Speed ratings Reference Limiting speed speed		Mass	Designation
d	D	B	C	C ₀	P _u			kg	–
mm			kN		kN	r/min		kg	–
100	180	46	400	475	57	4 000	5 000	5,1	* NUH 2220 ECMH
	215	73	710	800	91,5	3 200	4 300	13	* NUH 2320 ECMH
110	200	53	465	550	64	3 600	4 500	7,3	* NUH 2222 ECMH
	240	80	830	965	110	3 000	4 000	18	* NUH 2322 ECMH
120	215	58	550	670	76,5	3 400	4 000	9	* NUH 2224 ECMH
	260	86	965	1 120	125	2 800	3 600	22,5	* NUH 2324 ECMH
130	230	64	630	780	88	3 200	3 800	11	* NUH 2226 ECMH
	280	93	1 120	1 340	146	2 400	3 400	29	* NCF 2326 ECJB
	280	93	1 120	1 340	146	2 400	3 400	28	* NUH 2326 ECMH
140	250	68	680	880	96,5	2 800	3 600	14,5	* NCF 2228 ECJB
	250	68	680	880	96,5	2 800	3 600	14,5	* NUH 2228 ECMH
	300	102	1 250	1 530	163	2 400	3 200	35,5	* NCF 2328 ECJB
	300	102	1 250	1 530	163	2 400	3 200	35	* NUH 2328 ECMH
150	270	73	780	1 040	112	2 600	3 400	18	* NCF 2230 ECJB
	270	73	780	1 040	112	2 600	3 400	18	* NUH 2230 ECMH
	320	108	1 430	1 760	183	2 200	3 000	43,5	* NCF 2330 ECJB
	320	108	1 430	1 760	183	2 200	3 000	42	* NUH 2330 ECMH
160	290	80	980	1 270	134	2 400	3 000	23,5	* NCF 2232 ECJB
	290	80	980	1 270	134	2 400	3 000	23	* NUH 2232 ECMH
170	340	114	1 400	2 000	196	1 800	2 800	50,5	NCF 2332 ECJB
	340	114	1 600	2 000	196	2 000	2 800	50,5	* NCF 2332 ECJB/PEX
	340	114	1 400	2 000	196	1 800	2 800	50,5	NUH 2332 ECMH
	340	114	1 600	2 000	196	2 000	2 800	50,5	* NUH 2332 ECMH/PEX
170	310	86	1 160	1 530	156	2 200	2 800	28	* NCF 2234 ECJB
	310	86	1 160	1 530	156	2 200	2 800	28,5	* NUH 2234 ECMH
	360	120	1 540	2 200	216	1 700	2 600	58,5	NCF 2334 ECJB
	360	120	1 760	2 200	216	1 900	2 600	58,5	* NCF 2334 ECJB/PEX
	360	120	1 540	2 200	216	1 700	2 600	59,5	NUH 2334 ECMH
	360	120	1 760	2 200	216	1 900	2 600	59,5	* NUH 2334 ECMH/PEX

* SKF Explorer bearing

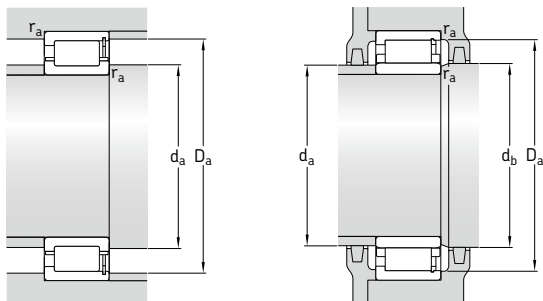

Dimensions						Abutment and fillet dimensions						Calculation factor
d	d ₁	D ₁	F, E	r _{1,2}	s ¹⁾	d _a	d _a	d _b	D _a	D _a	r _a	k _r
mm	~	~		min.		min.	max.	min.	min.	max.	max.	-
100	-	156	119	2,1	1	113	116	122	159	167	2	0,16
	-	182	127,5	3	2,2	114	124	131	186	199	2,5	0,2
110	-	173	132,5	2,1	2,2	122	129	135	177	187	2	0,16
	-	200	143	3	2,3	124	139	146	206	225	2,5	0,2
120	-	187	143,5	2,1	2,2	132	140	146	191	201	2	0,16
	-	218	154	3	2,4	134	150	157	224	244	2,5	0,2
130	-	201	153,5	3	2,6	144	150	157	205	215	2,5	0,16
	181	235	247	4	6,5	147	174	-	241	261	3	0,2
	-	235	167	4	3,1	147	163	170	241	261	3	0,2
140	179	216	225	3	4	154	174	-	220	235	2,5	0,16
	-	216	169	3	3,2	154	165	172	220	235	2,5	0,16
	195	251	264	4	7,3	157	188	-	257	282	3	0,2
	-	251	180	4	3,9	157	175	183	257	282	3	0,2
150	193	233	242	3	4,4	164	188	-	237	254	2,5	0,16
	-	233	182	3	3,3	164	178	186	237	254	2,5	0,16
	209	269	283	4	7,9	167	201	-	276	302	3	0,2
	-	285	193	4	4,1	167	188	196	284	302	3	0,2
160	205	250	261	3	4,1	174	199	-	256	274	2,5	0,16
	-	250	193	3	3	174	189	196	256	274	2,5	0,16
	221	281	300	4	8,3	177	213	-	290	321	3	0,2
	-	281	300	4	8,3	177	213	-	290	321	3	0,2
	-	285	204	4	2,5	177	199	207	292	321	3	0,2
	-	285	204	4	2,5	177	199	207	292	321	3	0,2
170	219	270	281	4	3,8	187	212	-	275	292	3	0,16
	-	269	205	4	2,4	187	201	208	275	292	3	0,16
	234	301	316	4	7,5	186	225	-	308	341	3	0,2
	234	301	316	4	7,5	186	225	-	308	341	3	0,2
	-	301	216	4	3,8	186	211	219	308	341	3	0,2
	-	301	216	4	3,8	186	211	219	308	341	3	0,2

¹⁾ Permissible axial displacement from the normal position of one bearing ring relative to the other.

5.2 High-capacity cylindrical roller bearings

d 180 – 240 mm

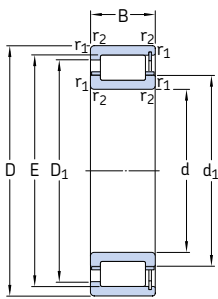

NCF..ECJB

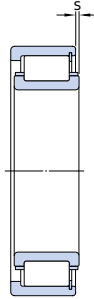

NUH..ECMH

Principal dimensions			Basic load ratings		Fatigue load limit	Speed ratings		Mass	Designation
d	D	B	dynamic	static		Reference speed	Limiting speed		
mm			C	C ₀	P _u	r/min		kg	–
180	320	86	1 200	1 600	166	2 200	2 800	30	* NCF 2236 ECJB
	320	86	1 200	1 600	166	2 200	2 800	29,5	* NUH 2236 ECMH
	380	126	1 720	2 400	232	1 600	2 400	67,5	NCF 2336 ECJB
	380	126	1 960	2 400	232	1 800	2 400	67,5	* NCF 2336 ECJB/PEX
	380	126	1 720	2 400	232	1 600	2 400	68	NUH 2336 ECMH
	380	126	1 960	2 400	232	1 800	2 400	68	* NUH 2336 ECMH/PEX
190	340	92	1 320	1 760	180	2 000	2 600	36,5	* NCF 2238 ECJB
	340	92	1 320	1 760	180	2 000	2 600	36	* NUH 2238 ECMH
	400	132	1 940	2 750	255	1 500	2 200	78	NCF 2338 ECJB
	400	132	2 240	2 750	255	1 700	2 200	78	* NCF 2338 ECJB/PEX
	400	132	1 940	2 750	255	1 500	2 200	78,5	NUH 2338 ECMH
	400	132	2 240	2 750	255	1 700	2 200	78,5	* NUH 2338 ECMH/PEX
200	360	98	1 460	2 000	200	1 900	2 400	43	* NCF 2240 ECJB
	360	98	1 460	2 000	200	1 900	2 400	43,5	* NUH 2240 ECMH
	420	138	2 200	3 200	300	1 400	2 200	91,5	NCF 2340 ECJB
	420	138	2 550	3 200	300	1 600	2 200	91,5	* NCF 2340 ECJB/PEX
	420	138	2 200	3 200	300	1 400	2 200	92,5	NUH 2340 ECMH
	420	138	2 550	3 200	300	1 600	2 200	92,5	* NUH 2340 ECMH/PEX
220	400	108	1 760	2 600	240	1 600	2 200	58,5	NCF 2244 ECJB
	400	108	2 000	2 600	240	1 700	2 200	58,5	* NCF 2244 ECJB/PEX
	400	108	1 760	2 600	240	1 600	2 200	59	NUH 2244 ECMH
	400	108	2 000	2 600	240	1 700	2 200	59	* NUH 2244 ECMH/PEX
	460	145	2 510	3 650	335	1 300	2 000	116	NUH 2344 ECMH
	460	145	2 900	3 650	335	1 400	2 000	116	* NUH 2344 ECMH/PEX
240	440	120	1 980	3 050	290	1 500	1 900	80	NUH 2248 ECMH
	440	120	2 279	3 050	290	1 600	1 900	80	* NUH 2248 ECMH/PEX
	500	155	2 750	4 000	345	1 200	1 800	143	NUH 2348 ECMH
	500	155	3 150	4 000	345	1 300	1 800	143	* NUH 2348 ECMH/PEX

* SKF Explorer bearing

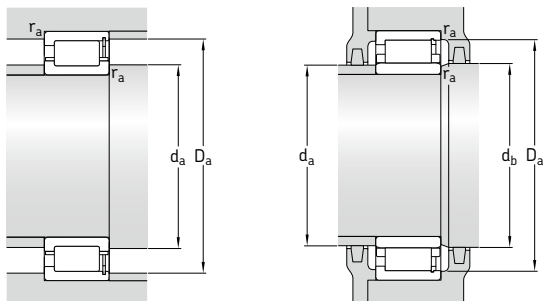

Dimensions						Abutment and fillet dimensions						Calculation factor
d	d ₁ ~	D ₁ ~	F, E	r _{1,2} min.	s ¹⁾	d _a min.	d _a max.	d _b min.	D _a min.	D _a max.	r _a max.	k _r
mm						mm						-
180	229	279	291	4	3,8	197	222	-	285	302	3	0,16
	-	279	215	4	2,4	197	211	218	285	302	3	0,16
	247	320	339	4	7,9	196	237	-	329	361	3	0,2
	-	320	339	4	7,9	196	237	-	329	361	3	0,2
	-	322	227	4	3,7	196	222	230	330	361	3	0,2
	-	322	204	4	3,7	196	222	230	311	361	3	0,2
190	242	293	308	4	4,5	207	235	-	300	321	3	0,16
	-	296	228	4	3,1	207	224	231	302	321	3	0,16
	262	342	360	5	7,1	209	251	-	351	380	4	0,2
	-	342	360	5	7,1	209	251	-	351	380	4	0,2
	-	342	240	5	4,1	209	234	244	351	380	4	0,2
	-	342	240	5	4,1	209	234	244	351	380	4	0,2
200	256	312	325	4	4,6	217	249	-	318	341	3	0,16
	-	312	241	4	3,4	217	236	245	318	341	3	0,16
	275	356	377	5	7,1	220	264	-	367	399	4	0,2
	-	356	377	5	7,1	220	264	-	367	399	4	0,2
	-	358	253	5	4,3	220	247	257	367	399	4	0,2
	-	358	253	5	4,3	220	247	257	367	399	4	0,2
220	279	349	367	4	7,1	237	269	-	358	383	3	0,16
	-	349	367	4	7,1	237	269	-	358	383	3	0,16
	-	350	259	4	2,5	237	254	263	359	383	3	0,16
	-	350	259	4	2,5	237	254	263	359	383	3	0,16
	-	392	277	5	3	240	270	281	334	439	4	0,2
	-	392	277	5	3	240	270	281	334	439	4	0,2
240	-	312	287	4	3,5	258	294	299	299	422	3	0,16
	-	312	287	4	3,5	258	294	299	299	422	3	0,16
	-	426	299	5	3,1	260	298	303	362	479	4	0,2
	-	426	299	5	3,1	260	298	303	362	479	4	0,2

¹⁾ Permissible axial displacement from the normal position of one bearing ring relative to the other.

5.3 Single row full complement cylindrical roller bearings d 20 – 75 mm

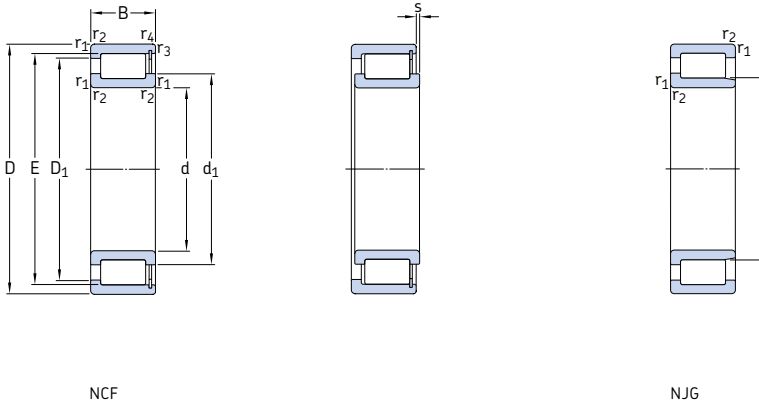

Principal dimensions			Basic load ratings		Fatigue load limit	Speed ratings		Mass	Designation
d	D	B	C	C ₀	P _u	Reference speed	Limiting speed	kg	–
mm			kN		kN	r/min		kg	–
20	42	16	28,1	28,5	3,1	8 500	10 000	0,11	NCF 3004 CV
25	47	16	31,9	35,5	3,8	7 000	9 000	0,12	NCF 3005 CV
	62	24	68,2	68	8,5	4 500	5 600	0,38	NJG 2305 VH
30	55	19	39,6	44	5	6 000	7 500	0,2	NCF 3006 CV
	72	27	84,2	86,5	11	4 000	4 800	0,56	NJG 2306 VH
35	62	20	48,4	56	6,55	5 300	6 700	0,26	NCF 3007 CV
	80	31	108	114	14,3	3 400	4 300	0,75	NJG 2307 VH
40	68	21	57,2	69,5	8,15	4 800	6 000	0,31	NCF 3008 CV
	90	33	145	156	20	3 000	3 600	1	NJG 2308 VH
45	75	23	60,5	78	9,15	4 300	5 300	0,4	NCF 3009 CV
	100	36	172	196	25,5	2 800	3 400	1,45	NJG 2309 VH
50	80	23	76,5	98	11,8	4 000	5 000	0,43	NCF 3010 CV
	55	90	26	105	140	17,3	3 400	4 300	0,64
		120	43	233	260	33,5	2 200	2 800	2,3
60	85	16	55	80	9,15	3 600	4 500	0,29	NCF 2912 CV
	95	26	106	146	18,3	3 400	4 000	0,69	NCF 3012 CV
65	90	16	58,3	88	10,2	3 200	4 000	0,31	NCF 2913 CV
	100	26	112	163	20	3 000	3 800	0,73	NCF 3013 CV
	140	48	303	360	46,5	1 900	2 400	3,55	NJG 2313 VH
70	100	19	76,5	116	13,7	3 000	3 800	0,49	NCF 2914 CV
	110	30	128	173	22,4	2 800	3 600	1	NCF 3014 CV
	150	51	336	400	50	1 800	2 200	4,4	NJG 2314 VH
75	105	19	79,2	125	14,6	2 800	3 600	0,52	NCF 2915 CV
	115	30	134	190	24,5	2 600	3 200	1,05	NCF 3015 CV
	160	55	396	480	60	1 600	2 000	5,35	NJG 2315 VH

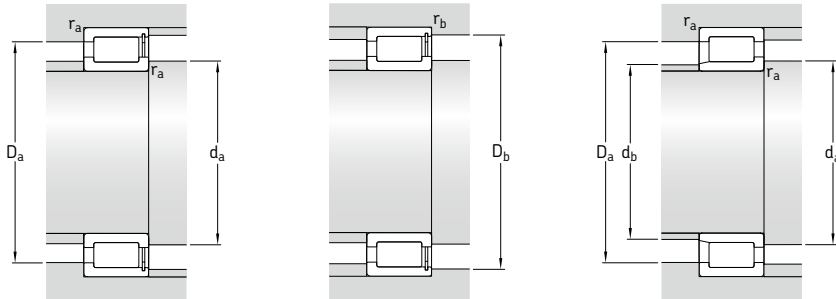

Dimensions				Abutment and fillet dimensions										Calculation factor
d	d ₁ ~	D ₁ ~	F, E	r _{1,2} min.	r _{3,4} min.	s ¹⁾	d _a min.	d _{as} ²⁾	d _b max.	D _a max.	D _b max.	r _a max.	r _b max.	k _r
mm							mm							-
20	29	33	36,81	0,6	0,3	1,5	24	26,9	-	38	39	0,6	0,3	0,3
25	34 36,1	39 48,2	42,51 31,74	0,6 1,1	0,3 -	1,5 1,7	29 31	32,3 33,9	- 30	43 55	44 -	0,6 1	0,3 -	0,3 0,35
30	40 43,2	45 56,4	49,6 38,36	1 1,1	0,3 -	2 1,8	35 37	37,8 40,8	- 36,5	50 64	52 -	1 1	0,3 -	0,3 0,35
35	45 50,4	51 65,8	55,52 44,75	1 1,5	0,3 -	2 2	40 43	42,8 47,6	- 42	57 71	58 -	1 1,5	0,3 -	0,3 0,35
40	50 57,6	58 75,2	61,74 51,15	1 1,5	0,3 -	2 2,4	45 49	47,9 54,4	- 49	63 81	65 -	1 1,5	0,3 -	0,3 0,35
45	55 62,5	62 80,1	66,85 56,14	1 1,5	0,3 -	2 2,4	50 54	53 59,3	- 54	70 91	71 -	1 1,5	0,3 -	0,3 0,35
50	59	68	72,33	1	0,3	2	54	56,7	-	75	76	1	0,3	0,3
55	68 75,5	79 98,6	83,54 67,14	1,1 2	0,6 -	2 2,6	62 65	65,8 71,3	- 64	84 109	86 -	1 2	0,6 -	0,3 0,35
60	69 71	74,5 82	78,65 86,74	1 1,1	0,6 0,6	2 1	64 66	66,8 68,9	- -	80 89	80 91	1 1	0,5 0,5	0,2 0,3
65	75,5 78 89,9	81 88 116	85,24 93,09 80,7	1 1,1 2,1	0,6 0,6 -	1 2 3	70 71 77	73,4 75,6 85,3	- - 78	85 94 128	86 95 -	1 1 2	0,5 0,5 -	0,2 0,3 0,35
70	80,5 81 93,8	88,5 95 121	92,5 100,28 84,2	1 1,1 2,1	0,6 0,6 -	1 3 3	75 75 81	78,5 78,6 89	- - 81	95 104 138	96 105 -	1 1 2	0,5 0,5 -	0,2 0,3 0,35
75	86 89 101	93 103 131	97,5 107,9 91,2	1 1,1 2,1	0,6 1,1 -	1 3 3	80 81 87	83,8 86,5 96,1	- - 88	100 109 147	101 110 -	1 1 2	0,5 1 -	0,2 0,3 0,35

¹⁾ Permissible axial displacement from the normal position of one bearing ring relative to the other.

²⁾ Recommended shaft abutment diameter for axially loaded bearings → *Flange support*, page 598.

5.3 Single row full complement cylindrical roller bearings d 80 – 150 mm

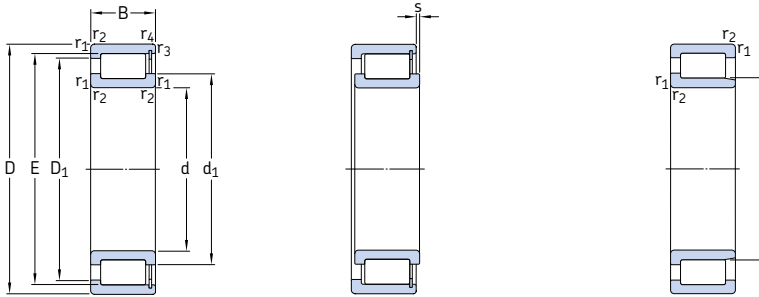

NCF

NJG

Principal dimensions			Basic load ratings		Fatigue load limit	Speed ratings		Mass	Designation
d	D	B	C	C ₀		Reference speed	Limiting speed		
mm			kN		kN	r/min		kg	–
80	110	19	80,9	132	15,6	2 600	3 400	0,55	NCF 2916 CV
	125	34	165	228	29	2 400	3 000	1,45	NCF 3016 CV
	170	58	457	570	71	1 500	1 900	6,4	NJG 2316 VH
85	120	22	102	166	20	2 600	3 200	0,81	NCF 2917 CV
	130	34	172	236	30	2 400	3 000	1,5	NCF 3017 CV
	180	60	484	620	76,5	1 400	1 800	7,4	NJG 2317 VH
90	125	22	105	176	20,8	2 400	3 000	0,84	NCF 2918 CV
	140	37	198	280	35,5	2 200	2 800	1,95	NCF 3018 CV
	190	64	528	670	81,5	1 400	1 800	8,75	NJG 2318 VH
100	140	24	128	200	24,5	2 200	2 600	1,15	NCF 2920 CV
	150	37	209	310	37,5	2 000	2 600	2,15	NCF 3020 CV
	215	73	682	865	104	1 200	1 500	13	NJG 2320 VH
110	150	24	134	220	26	1 900	2 400	1,25	NCF 2922 CV
	170	45	275	400	47,5	1 800	2 200	3,5	NCF 3022 CV
	240	80	858	1 060	122	1 100	1 300	17,5	NJG 2322 VH
120	165	27	172	290	34,5	1 800	2 200	1,75	NCF 2924 CV
	180	46	292	440	52	1 700	2 000	3,8	NCF 3024 CV
	215	58	512	735	85	1 400	1 700	9,05	NCF 2224 V
	260	86	952	1 250	140	1 000	1 200	22,5	NJG 2324 VH
130	180	30	205	360	40,5	1 600	2 000	2,35	NCF 2926 CV
	200	52	413	620	72	1 500	1 900	5,8	NCF 3026 CV
	280	93	1 080	1 430	156	950	1 200	28	NJG 2326 VH
140	190	30	220	390	43	1 500	1 900	2,4	NCF 2928 CV
	210	53	440	680	78	1 400	1 800	6,1	NCF 3028 CV
	250	68	693	1 020	114	1 200	1 500	14,5	NCF 2228 V
	300	102	1 210	1 600	173	850	1 100	35,5	NJG 2328 VH
150	210	36	292	490	55	1 400	1 700	3,75	NCF 2930 CV
	225	56	457	710	80	1 300	1 600	7,5	NCF 3030 CV
	270	73	792	1 180	132	1 100	1 400	18,5	NCF 2230 V
	320	108	1 450	1 930	196	800	1 000	42,5	NJG 2330 VH

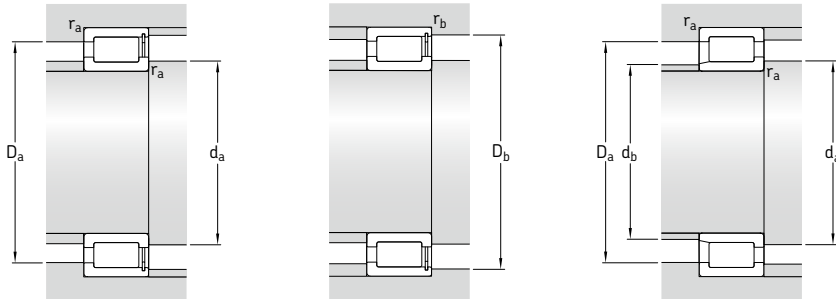

Dimensions							Abutment and fillet dimensions						Calculation factor	
d	d ₁	D ₁	F, E	r _{1,2} min.	r _{3,4} min.	s ¹⁾	d _a min.	d _{as} ²⁾	d _b max.	D _a max.	D _b max.	r _a max.	r _b max.	k _r
mm	~	~					mm							-
80	90,5	99	102,7	1	0,6	1	85	88,6	-	105	106	1	0,5	0,2
	95	111	116,99	1,1	0,6	4	86	92	-	119	120	1	0,5	0,3
	109	141	98,3	2,1	-	4	92	104	95	157	-	2	-	0,35
85	96	105	109,5	1,1	1	1	90	93,8	-	114	114	1	1	0,2
	99	116	121,44	1,1	0,6	4	91	96,2	-	123	125	1	0,5	0,3
	118	149	107	3	-	4	100	113	104	165	-	2,5	-	0,35
90	102	111	115,6	1,1	1	1	96	99,8	-	119	119	1	1	0,2
	106	124	130,11	1,5	1	4	97	103	-	133	133	1,5	1	0,3
	117	152	105,26	3	-	4	102	111	102	176	-	2,5	-	0,35
100	114	126	130,6	1,1	1	1,3	106	111	-	134	134	1	1	0,2
	115	134	139,65	1,5	1	4	107	112	-	142	143	1,5	1	0,3
	133	173	122,8	3	-	4	114	128	119	201	-	2,5	-	0,35
110	124	136	141,1	1,1	1	1,3	116	122	-	144	144	1	1	0,2
	127	149	156,13	2	1	5,5	119	124	-	160	163	2	1	0,3
	151	198	134,3	3	-	5	124	143	130	225	-	2,5	-	0,35
120	136	149	154,3	1,1	1	1,3	126	133	-	159	159	1	1	0,2
	139	160	167,58	2	1	5,5	129	135	-	170	174	2	1	0,3
	150	184	192,32	2,1	2,1	4	131	145	-	204	204	2	2	0,3
	164	213	147,39	3	-	5	134	156	143	245	-	2,5	-	0,35
130	147	161	167,1	1,5	1,1	2	138	144	-	172	173	1,5	1	0,2
	149	175	183,81	2	1	5,5	138	144	-	190	193	2	1	0,3
	175	226	157,9	4	-	6	147	166	153	263	-	3	-	0,35
140	158	173	180	1,5	1,1	2	148	155	-	182	183	1,5	1	0,2
	163	189	197,82	2	1	5,5	150	158	-	200	203	2	1	0,3
	173	212	221,92	3	3	5	153	167	-	236	236	2,5	2,5	0,3
	187	241	168,5	4	-	6,5	157	178	163	283	-	3	-	0,35
150	169	189	196,4	2	1,1	2	159	166	-	201	203	2	1	0,2
	170	198	206,8	2,1	1,1	7	159	165	-	214	217	2	1	0,3
	184	227	236,71	3	3	6	163	178	-	256	256	2,5	2,5	0,3
	202	261	182,5	4	-	6,5	168	192	178	302	-	3	-	0,35

¹⁾ Permissible axial displacement from the normal position of one bearing ring relative to the other.

²⁾ Recommended shaft abutment diameter for axially loaded bearings → *Flange support*, page 598.

5.3 Single row full complement cylindrical roller bearings d 160 – 260 mm

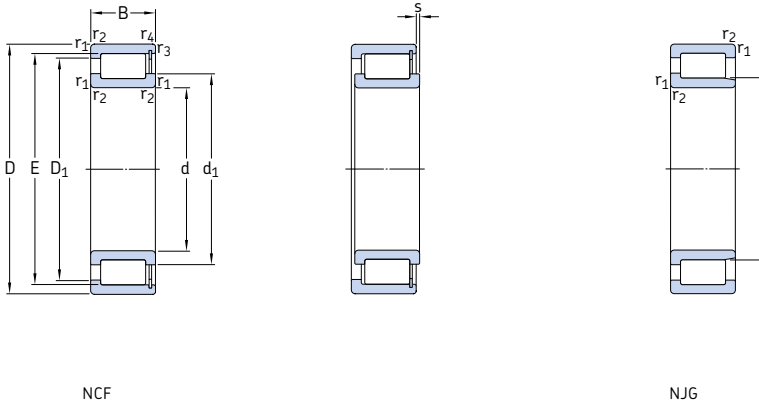

Principal dimensions	Basic load ratings		Fatigue load limit	Speed ratings		Mass	Designation		
	dynamic	static		Reference speed	Limiting speed				
d	D	B	C	C ₀	P _u				
mm			kN		kN	r/min	kg	–	
160	220	36	303	530	58,5	1 300	1 600	4	NCF 2932 CV
	240	60	512	800	90	1 200	1 500	9,1	NCF 3032 CV
	290	80	990	1 500	160	950	1 200	23	NCF 2232 V
170	230	36	314	560	60	1 200	1 500	4,3	NCF 2934 CV
	260	67	671	1 060	118	1 100	1 400	12,5	NCF 3034 CV
	310	86	1 100	1 700	176	900	1 100	28,5	NCF 2234 V
	360	120	1 760	2 450	236	700	900	59,5	NJG 2334 VH
180	250	42	391	695	75	1 100	1 400	6,2	NCF 2936 CV
	280	74	781	1 250	134	1 100	1 300	16,5	NCF 3036 CV
	380	126	1 870	2 650	255	670	800	69,5	NJG 2336 VH
190	260	42	440	780	81,5	1 100	1 400	6,5	NCF 2938 CV
	290	75	792	1 290	140	1 000	1 300	17	NCF 3038 CV
	400	132	2 160	3 000	280	630	800	80	NJG 2338 VH
200	250	24	176	335	32,5	1 100	1 400	2,6	NCF 1840 V
	280	48	528	965	100	1 000	1 300	9,1	NCF 2940 CV
	310	82	913	1 530	160	950	1 200	22,5	NCF 3040 CV
	420	138	2 290	3 200	290	600	750	92	NJG 2340 VH
220	270	24	183	365	34,5	1 000	1 200	2,85	NCF 1844 V
	300	48	550	1 060	106	950	1 200	9,9	NCF 2944 CV
	340	90	1 080	1 800	186	850	1 100	29,5	NCF 3044 CV
	400	108	1 830	2 750	255	700	850	58	NCF 2244 V
	460	145	2 700	3 750	335	530	670	111	NJG 2344 VH
240	300	28	260	510	47,5	900	1 100	4,4	NCF 1848 V
	320	48	583	1 140	114	850	1 100	10,5	NCF 2948 CV
	360	92	1 140	1 960	200	800	1 000	32	NCF 3048 CV
	500	155	2 810	3 900	345	500	630	147	NJG 2348 VH
260	320	28	270	550	50	800	1 000	4,75	NCF 1852 V
	360	60	737	1 430	143	750	950	18,5	NCF 2952 CV
	400	104	1 540	2 550	250	700	900	46,5	NCF 3052 CV
	540	165	3 580	5 000	430	430	530	177	NJG 2352 VH

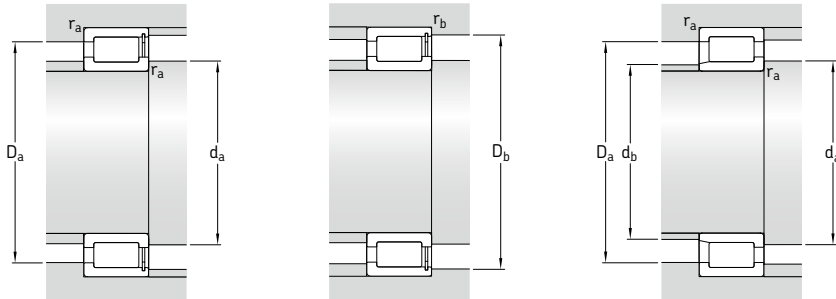

Dimensions							Abutment and fillet dimensions						Calculation factor	
d	d ₁	D ₁	F, E	r _{1,2} min.	r _{3,4} min.	s ¹⁾	d _a min.	d _{as} ²⁾	d _b max.	D _a max.	D _b max.	r _a max.	r _b max.	k _r
mm														
160	180	200	207,2	2	1,1	2,5	169	177	–	211	211	2	1	0,2
	185	215	224,86	2,1	1,1	7	171	180	–	230	233	2	1	0,3
	208	255	266,36	3	3	6	176	201	–	276	276	2,5	2,5	0,3
170	191	211	218	2	1,1	2,5	179	188	–	221	223	2	1	0,2
	198	232	242,85	2,1	1,1	7	181	192	–	249	252	2	1	0,3
	219	269	281,09	4	4	7	189	212	–	295	294	3	3	0,3
	227	291	203,55	4	–	7	187	215	198	342	–	3	–	0,35
180	203	223	232	2	1,1	2,5	189	199	–	241	243	2	1	0,2
	212	248	260,22	2,1	2,1	7	192	206	–	269	269	2	2	0,3
	245	309	221,75	4	–	8	199	233	215	361	–	3	–	0,35
190	212	236	244	2	1,1	2	199	208	–	250	252	2	1	0,2
	222	258	269,76	2,1	2,1	8	202	216	–	279	279	2	2	0,3
	250	320	228,11	5	–	8	210	239	222	378	–	4	–	0,35
200	218	231	237,5	1,5	1,1	1,8	207	215	–	243	244	1,5	1	0,1
	226	253	262	2,1	1,5	3	211	222	–	269	271	2	1,5	0,2
	237	275	287,75	2,1	2,1	9	213	230	–	299	299	2	2	0,3
	266	342	238,65	5	–	9	221	252	232	398	–	4	–	0,35
220	238	252	258	1,5	1,1	1,8	227	235	–	263	264	1,5	1	0,1
	247	274	283	2,1	1,5	3	231	243	–	289	291	2	1,5	0,2
	255	298	312,2	3	3	9	233	248	–	327	327	2,5	2,5	0,3
	277	349	366	4	4	8	239	268	–	385	383	3	3	0,3
	295	383	266,7	5	–	10	240	281	259	440	–	4	–	0,35
240	263	279	287	2	1,1	1,8	249	259	–	291	294	2	1	0,1
	267	294	303	2,1	1,5	3	251	263	–	309	311	2	1,5	0,2
	278	321	335,1	3	3	11	254	271	–	347	347	2,5	2,5	0,3
	310	403	280,55	5	–	10	260	295	282	480	–	4	–	0,35
260	283	299	307,2	2	1,1	1,8	269	279	–	311	313	2	1	0,1
	291	323	333,7	2,1	1,5	3,5	271	287	–	348	350	2	1,5	0,2
	304	358	375,97	4	4	11	277	295	–	384	384	3	3	0,3
	349	456	315,9	6	–	11	286	332	308	514	–	5	–	0,35

¹⁾ Permissible axial displacement from the normal position of one bearing ring relative to the other.

²⁾ Recommended shaft abutment diameter for axially loaded bearings → *Flange support*, page 598.

5.3 Single row full complement cylindrical roller bearings d 280 – 440 mm

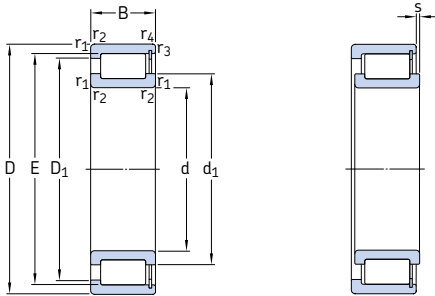

Principal dimensions			Basic load ratings		Fatigue load limit	Speed ratings		Mass	Designation
d	D	B	C	C ₀		Reference speed	Limiting speed		
mm			kN		kN	r/min		kg	–
280	350	33	341	695	64	750	950	7,1	NCF 1856 V
	380	60	880	1 730	166	700	900	19,5	NCF 2956 CV
	420	106	1 570	2 650	260	670	850	50	NCF 3056 CV
300	380	38	418	850	75	670	850	10	NCF 1860 V
	420	72	1 120	2 200	208	670	800	31	NCF 2960 CV
	460	118	1 900	3 250	300	600	750	69	NCF 3060 CV
320	400	38	440	900	80	630	800	10,5	NCF 1864 V
	440	72	1 140	2 360	220	600	750	33	NCF 2964 V
	480	121	1 980	3 450	310	560	700	74,5	NCF 3064 CV
340	420	38	446	950	83	600	750	11	NCF 1868 V
	460	72	1 190	2 500	228	560	700	35	NCF 2968 V
	520	133	2 380	4 150	355	530	670	100	NCF 3068 CV
360	440	38	402	900	76,5	560	700	11,5	NCF 1872 V
	480	72	1 230	2 600	240	530	670	36,5	NCF 2972 CV
	540	134	2 420	4 300	365	500	630	105	NCF 3072 CV
380	480	46	627	1 290	114	530	670	19,5	NCF 1876 V
	520	82	1 570	3 250	300	500	630	52	NCF 2976 V
	560	135	2 700	5 100	425	480	600	110	NCF 3076 V
400	500	46	627	1 340	118	500	630	20,5	NCF 1880 V
	540	82	1 650	3 450	310	480	600	54,5	NCF 2980 CV
	600	148	2 970	5 500	450	450	560	145	NCF 3080 CV
420	520	46	660	1 430	122	480	600	20,5	NCF 1884 V
	560	82	1 650	3 600	315	450	560	57	NCF 2984 V
	620	150	3 030	5 700	455	430	530	150	NCF 3084 CV
440	540	46	671	1 460	125	450	560	22	NCF 1888 V
	540	60	1 060	2 700	232	450	560	30	NCF 2888 V
	600	95	2 010	4 400	380	430	530	80	NCF 2988 V

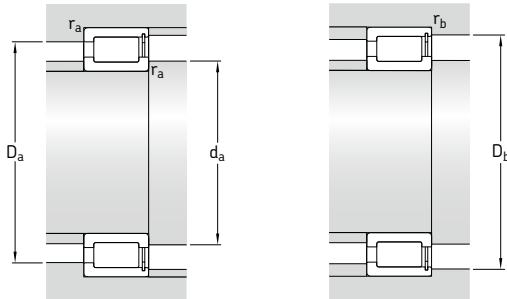

Dimensions				Abutment and fillet dimensions								Calculation factor		
d	d ₁	D ₁	E	r _{1,2} min.	r _{3,4} min.	s ¹⁾	d _a min.	d _{as} ²⁾	D _a max.	D _b max.	r _a max.	r _b max.	k _r	
mm														
280	307	325	334	2	1,1	2,5	290	303	–	341	343	2	1	0,1
	314	348	359,1	2,1	1,5	3	291	309	–	368	370	2	1,5	0,2
	319	373	390,3	4	4	11	295	310	–	404	404	3	3	0,3
300	331	353	363	2,1	1,5	3	311	326	–	369	372	2	1,5	0,1
	341	375	390,5	3	3	5	314	334	–	405	405	2,5	2,5	0,2
	355	413	433	4	4	14	315	344	–	445	445	3	3	0,3
320	351	373	383	2,1	1,5	3	331	346	–	389	392	2	1,5	0,1
	359	401	411	3	3	5	333	353	–	427	427	2,5	2,5	0,2
	368	434	449	4	4	14	335	359	–	465	465	3	3	0,3
340	371	393	403	2,1	1,5	3	351	366	–	409	412	2	1,5	0,1
	378	421	431	3	3	5	353	373	–	447	447	2,5	2,5	0,2
	395	468	485	5	5	14	358	384	–	502	502	4	4	0,3
360	388	413	418,9	2,1	1,5	3	371	384	–	429	433	2	1,5	0,1
	404	437	451,5	3	3	5	373	396	–	467	467	2,5	2,5	0,2
	412	486	503	5	5	14	378	402	–	522	522	4	4	0,3
380	416	448	458	2,1	1,5	3,5	391	411	–	469	473	2	1,5	0,1
	427	474	488	4	4	5	395	420	–	505	505	3	3	0,2
	431	504	520,5	5	5	14	398	420	–	542	542	4	4	0,3
400	433	465	475	2,1	1,5	3,5	411	428	–	489	493	2	1,5	0,1
	449	499	511	4	4	5	415	442	–	525	525	3	3	0,2
	460	540	558	5	5	14	418	449	–	582	582	4	4	0,3
420	457	489	499	2,1	1,5	3,5	431	452	–	509	513	2	1,5	0,1
	462	512	524	4	4	5	435	455	–	545	545	3	3	0,2
	480	559	577,6	5	5	15	438	469	–	602	602	4	4	0,3
440	474	506	516	2,1	1,5	3,5	451	469	–	529	533	2	1,5	0,1
	474	508	516	2,1	1,5	3,5	451	469	–	529	533	2	1,5	0,11
	502	545	565,5	4	4	6	455	492	–	585	585	3	3	0,2

¹⁾ Permissible axial displacement from the normal position of one bearing ring relative to the other.

²⁾ Recommended shaft abutment diameter for axially loaded bearings → *Flange support*, page 598.

5.3 Single row full complement cylindrical roller bearings d 460 – 670 mm

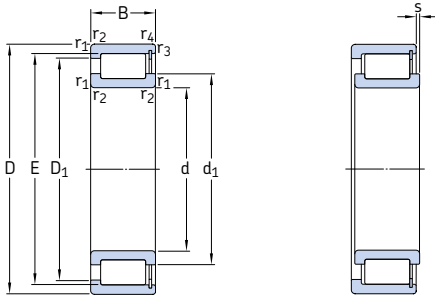

Principal dimensions			Basic load ratings		Fatigue load limit	Speed ratings		Mass	Designation
d	D	B	C	C ₀		Reference speed	Limiting speed		
mm			kN		kN	r/min		kg	–
460	580	72	1 300	3 050	260	430	530	44	NCF 2892 V/HB1
	620	95	2 050	4 500	390	400	500	83	NCF 2992 V
	680	163	3 690	6 950	540	380	480	195	NCF 3092 CV
480	600	56	935	2 040	170	400	500	35,5	NCF 1896 V
	600	72	1 320	3 150	265	400	500	46	NCF 2896 V
	650	100	2 290	4 900	405	380	480	93	NCF 2996 V
	700	165	3 740	7 200	550	360	450	205	NCF 3096 CV
500	620	56	952	2 120	173	380	480	35,5	NCF 18/500 V
	620	72	1 320	3 350	275	380	480	48	NCF 28/500 V
	670	100	2 330	5 000	415	380	450	100	NCF 29/500 V
	720	167	3 800	7 500	570	360	450	215	NCF 30/500 CV
530	650	56	990	2 240	180	360	450	38,5	NCF 18/530 V
	650	72	1 400	3 450	285	360	450	49,5	NCF 28/530 V
	710	106	2 700	6 000	465	340	430	120	NCF 29/530 V
	780	185	5 230	10 600	780	320	400	300	NCF 30/530 V
560	680	56	1 020	2 360	186	340	430	40,5	NCF 18/560 V/HB1
	680	72	1 420	3 650	300	340	430	54	NCF 28/560 V
	750	112	3 080	6 700	500	320	400	140	NCF 29/560 V/HB1
	820	195	5 830	11 800	865	300	380	345	NCF 30/560 V
600	730	60	1 050	2 550	196	320	400	51,5	NCF 18/600 V
	730	78	1 570	4 300	340	320	400	67,5	NCF 28/600 V/HB1
	800	118	3 190	7 100	520	300	380	170	NCF 29/600 V
630	780	69	1 250	2 900	232	300	360	72,5	NCF 18/630 V
	780	88	1 870	5 000	390	300	360	92,5	NCF 28/630 V
	850	128	3 740	8 650	610	280	340	205	NCF 29/630 V
670	820	69	1 300	3 150	245	280	340	76,5	NCF 18/670 V
	820	88	1 940	5 300	415	280	340	98	NCF 28/670 V
	900	136	3 910	9 000	630	260	320	245	NCF 29/670 V

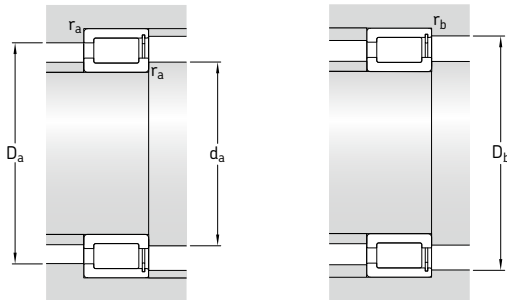

Dimensions				Abutment and fillet dimensions								Calculation factor		
d	d ₁	D ₁	E	r _{1,2} min.	r _{3,4} min.	s ¹⁾	d _a min.	d _{as} ²⁾	D _a max.	D _b max.	r _a max.	r _b max.	k _r	
mm	~	~					mm						-	
460	501	543	553	3	3	5	473	495	-	567	567	2,5	2,5	0,11
	516	558	579	4	4	6	475	506	-	605	605	3	3	0,2
	522	611	632,97	6	6	16	483	511	-	657	657	5	5	0,3
480	522	561	573,5	3	3	5	493	516	-	587	587	2,5	2,5	0,1
	520	562	573,5	3	3	5	493	515	-	587	587	2,5	2,5	0,11
	538	584	615	5	5	7	498	527	-	632	632	4	4	0,2
	546	628	654	6	6	16	503	532	-	677	677	5	5	0,3
500	542	582	594	3	3	5	513	536	-	607	607	2,5	2,5	0,1
	541	582	594,5	3	3	2,4	513	536	-	607	607	2,5	2,5	0,11
	553	611	630	5	5	7	518	544	-	652	652	4	4	0,2
	565	650	676	6	6	16	523	553	-	697	697	5	5	0,3
530	573	612	624,5	3	3	5	543	567	-	637	637	2,5	2,5	0,1
	572	614	624,5	3	3	5	543	566	-	637	637	2,5	2,5	0,11
	598	648	673	5	5	7	548	587	-	692	692	4	4	0,2
	610	702	732	6	6	16	553	595	-	757	757	5	5	0,3
560	603	643	655	3	3	5	573	597	-	667	667	2,5	2,5	0,1
	606	637	655	3	3	4,3	573	599	-	667	667	2,5	2,5	0,11
	628	682	709	5	5	7	578	615	-	732	732	4	4	0,2
	642	738	770	6	6	16	583	626	-	797	797	5	5	0,3
600	644	684	696	3	3	7	613	638	-	717	717	2,5	2,5	0,1
	642	685	696	3	3	5,4	613	637	-	717	717	2,5	2,5	0,11
	662	726	754	5	5	7	618	652	-	782	782	4	4	0,2
630	681	725	739	4	4	8	645	674	-	765	765	3	3	0,1
	680	728	739	4	4	8	645	674	-	765	765	3	3	0,11
	709	788	807	6	6	8	653	698	-	827	827	5	5	0,2
670	725	769	783	4	4	8	685	718	-	805	805	3	3	0,1
	724	772	783	4	4	8	685	718	-	805	805	3	3	0,11
	748	827	846	6	6	10	693	737	-	877	877	5	5	0,2

¹⁾ Permissible axial displacement from the normal position of one bearing ring relative to the other.

²⁾ Recommended shaft abutment diameter for axially loaded bearings → *Flange support*, page 598.

5.3 Single row full complement cylindrical roller bearings d 710 – 1 120 mm

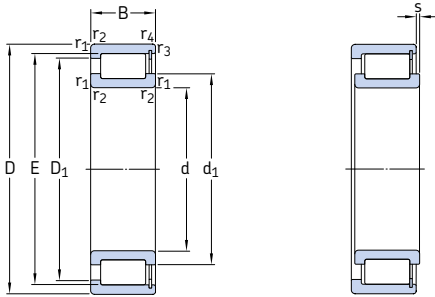

Principal dimensions			Basic load ratings		Fatigue load limit	Speed ratings		Mass	Designation
d	D	B	C	C ₀		Reference speed	Limiting speed		
mm			kN		kN	r/min		kg	–
710	870	74	1 540	3 750	285	260	320	92,5	NCF 18/710 V
	870	95	2 330	6 300	480	260	320	115	NCF 28/710 V
	950	140	4 290	10 000	695	240	300	275	NCF 29/710 V
750	920	78	1 870	4 500	335	240	300	110	NCF 18/750 V
	920	100	2 640	6 950	520	240	300	138	NCF 28/750 V
	1 000	145	4 460	10 600	710	220	280	315	NCF 29/750 V
800	980	82	1 940	4 800	345	220	280	126	NCF 18/800 V
	980	106	2 750	7 500	550	220	280	165	NCF 28/800 V
	1 060	150	4 950	12 000	800	200	260	359	NCF 29/800 V
850	1 030	82	2 050	5 200	375	200	260	131	NCF 18/850 V
	1 030	106	2 860	8 000	570	200	260	175	NCF 28/850 V
	1 120	155	5 230	12 700	830	190	240	406	NCF 29/850 V
900	1 090	85	2 240	5 700	405	190	240	154	NCF 18/900 V/HB1
	1 090	112	3 190	9 150	655	190	240	208	NCF 28/900 V
	1 180	165	5 940	14 600	950	170	220	472	NCF 29/900 V
950	1 150	90	2 420	6 300	440	170	220	185	NCF 18/950 V
	1 150	118	3 410	9 800	655	170	220	240	NCF 28/950 V
	1 250	175	6 660	16 300	1 020	160	200	565	NCF 29/950 V
1 000	1 220	100	2 920	7 500	455	160	200	230	NCF 18/1000 V
	1 220	128	4 130	11 600	720	160	200	310	NCF 28/1000 V
	1 320	185	7 480	18 600	1 160	150	190	680	NCF 29/1000 V
1 120	1 360	106	3 740	9 650	585	130	170	298	NCF 18/1120 V

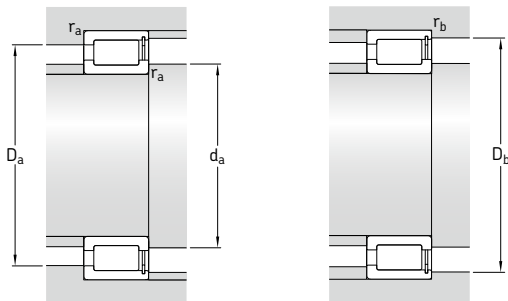

Dimensions				Abutment and fillet dimensions								Calculation factor		
d	d ₁ ~	D ₁ ~	E	r _{1,2} min.	r _{3,4} min.	s ¹⁾	d _a min.	d _{as} ²⁾	D _a max.	D _b max.	r _a max.	r _b max.	k _F	
mm														-
710	767	815	831	4	4	8	725	759	-	855	855	3	3	0,1
	766	818	831	4	4	8	725	759	-	855	855	3	3	0,11
	790	876	896	6	6	10	733	761	-	927	927	5	5	0,2
750	811	863	880	5	5	8	768	802	-	902	902	4	4	0,1
	810	867	878	5	5	8	768	799	-	902	902	4	4	0,11
	832	918	938	6	6	11	773	820	-	977	977	5	5	0,2
800	863	922	936	5	5	9	818	855	-	962	962	4	4	0,1
	863	922	936	5	5	10	818	855	-	962	962	4	4	0,11
	891	981	1002	6	6	11	823	860	-	1037	1037	5	5	0,2
850	911	972	986	5	5	9	868	903	-	1012	1012	4	4	0,1
	911	972	986	5	5	10	868	903	-	1012	1012	4	4	0,11
	943	1039	1061	6	6	13	873	914	-	1097	1097	5	5	0,2
900	966	1029	1044	5	5	9	918	957	-	1072	1072	4	4	0,1
	966	1029	1044	5	5	10	918	957	-	1072	1072	4	4	0,11
	996	1096	1120	6	6	13	923	982	-	1127	1127	5	5	0,2
950	1021	1087	1103	5	5	10	968	1012	-	1132	1132	4	4	0,1
	1021	1087	1103	5	5	12	968	1012	-	1132	1132	4	4	0,11
	1048	1154	1179	7,5	7,5	14	978	1033	-	1222	1222	6	6	0,2
1000	1073	1148	1165	6	6	12	1023	1063	-	1197	1197	5	5	0,1
	1073	1148	1165	6	6	12	1023	1063	-	1197	1197	5	5	0,11
	1113	1226	1252	7,5	7,5	14	1028	1091	-	1292	1292	6	6	0,2
1120	1206	1290	1310	6	6	12	1143	1194	-	1337	1337	5	5	0,1

¹⁾ Permissible axial displacement from the normal position of one bearing ring relative to the other.

²⁾ Recommended shaft abutment diameter for axially loaded bearings → *Flange support*, page 598.

5.4 Double row full complement cylindrical roller bearings d 20 – 85 mm

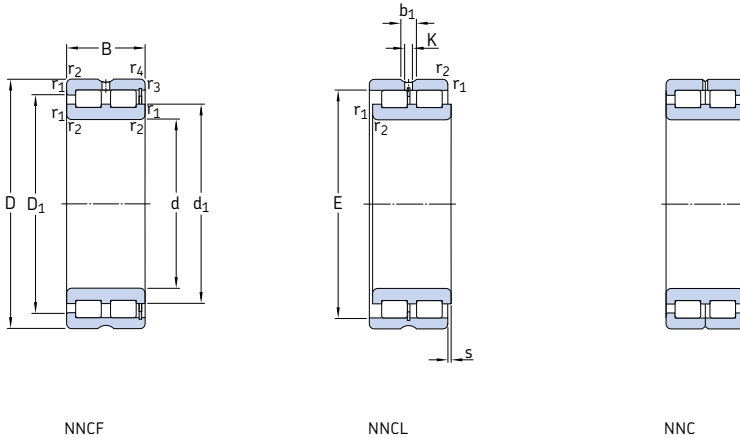

Principal dimensions			Basic load ratings		Fatigue load limit	Speed ratings		Mass	Designation
d	D	B	dynamic	static		Reference speed	Limiting speed		
mm			C	C ₀	P _u	r/min		kg	–
20	42	30	52,3	57	6,2	8 500	10 000	0,2	NNCF 5004 CV
25	47	30	59,4	71	7,65	7 000	9 000	0,23	NNCF 5005 CV
30	55	34	73,7	88	10	6 000	7 500	0,35	NNCF 5006 CV
35	62	36	89,7	112	12,9	5 300	6 700	0,46	NNCF 5007 CV
40	68	38	106	140	16,3	4 800	6 000	0,56	NNCF 5008 CV
45	75	40	112	156	18,3	4 300	5 300	0,71	NNCF 5009 CV
50	80	40	142	196	23,6	4 000	5 000	0,76	NNCF 5010 CV
55	90	46	190	280	34,5	3 400	4 300	1,15	NNCF 5011 CV
60	85	25	78,1	137	14,3	3 600	4 500	0,48	NNCF 4912 CV
	85	25	78,1	137	14,3	3 600	4 500	0,49	NNC 4912 CV
	85	25	78,1	137	14,3	3 600	4 500	0,47	NNCL 4912 CV
	95	46	198	300	36,5	3 400	4 000	1,25	NNCF 5012 CV
65	100	46	209	325	40	3 000	3 800	1,3	NNCF 5013 CV
70	100	30	114	193	22,4	3 000	3 800	0,77	NNCF 4914 CV
	100	30	114	193	22,4	3 000	3 800	0,78	NNC 4914 CV
	100	30	114	193	22,4	3 000	3 800	0,75	NNCL 4914 CV
	110	54	238	345	45	2 800	3 600	1,85	NNCF 5014 CV
75	115	54	251	380	49	2 600	3 200	1,95	NNCF 5015 CV
80	110	30	121	216	25	2 600	3 400	0,87	NNCF 4916 CV
	110	30	121	216	25	2 600	3 400	0,88	NNC 4916 CV
	110	30	121	216	25	2 600	3 400	0,85	NNCL 4916 CV
	125	60	308	455	58,5	2 400	3 000	2,6	NNCF 5016 CV
85	130	60	314	475	60	2 400	3 000	2,7	NNCF 5017 CV

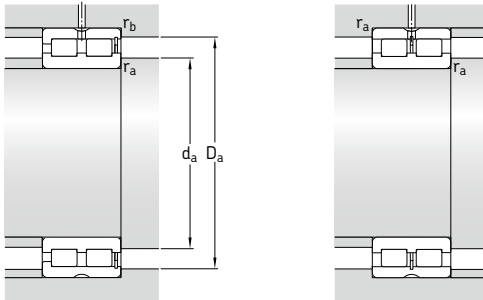

Dimensions										Abutment and fillet dimensions					Calculation factor
d	d ₁	D ₁	E	b ₁	K	r _{1,2} min.	r _{3,4} min.	s ¹⁾	d _a min.	d _{as} ²⁾	D _a max.	r _a max.	r _b max.	k _r	
mm										mm					-
20	28,4	33,2	36,81	4,5	3	0,6	0,3	1	23,2	25,6	38,7	0,5	0,3	0,5	
25	34,5	38,9	42,51	4,5	3	0,6	0,3	1	28,7	31,5	43,5	0,5	0,3	0,5	
30	40	45,3	49,6	4,5	3	1	0,3	1,5	34,7	37,8	50,3	1	0,3	0,5	
35	44,9	51,3	55,52	4,5	3	1	0,3	1,5	40,2	42,6	57,5	1	0,3	0,5	
40	50,5	57,2	61,74	4,5	3	1	0,3	1,5	44,8	47,7	63,3	1	0,3	0,5	
45	55,3	62,5	66,85	4,5	3	1	0,3	1,5	50,2	52,8	70	1	0,3	0,5	
50	59,1	67,6	72,23	4,5	3	1	0,3	1,5	55,5	56,7	74,8	1	0,3	0,5	
55	68,5	78,7	83,54	4,5	3,5	1,1	0,6	1,5	61	64,8	84	1	0,5	0,5	
60	70,5	73,5	77,51	4,5	3,5	1	1	1	64,7	67,6	80,5	1	1	0,25	
	70,5	73,5	77,51	4,5	3,5	1	-	-	64,7	67,6	80,5	1	-	0,25	
	70,5	-	77,51	4,5	3,5	1	-	1	64,7	-	80,5	1	-	0,25	
	71,7	81,9	86,74	4,5	3,5	1,1	0,6	1,5	66	68,9	89	1	0,5	0,5	
65	78,1	88,3	93,09	4,5	3,5	1,1	0,6	1,5	72	75	94	1	0,5	0,5	
70	83	87	91,87	4,5	3,5	1	1	1	75,2	79	95	1	1	0,25	
	83	87	91,87	4,5	3,5	1	-	-	75,2	79	95	1	-	0,25	
	83	-	91,87	4,5	3,5	1	-	1	75,2	-	95	1	-	0,25	
	81,5	95	100,28	5	3,5	1,1	0,6	3	76	79	105	1	0,5	0,5	
75	89	103	107,9	5	3,5	1,1	0,6	3	81	85	109	1	0,5	0,5	
80	91,4	96	100,78	5	3,5	1	1	1	84,8	88	105	1	1	0,25	
	91,4	96	100,78	5	3,5	1	-	-	84,8	88	105	1	-	0,25	
	91,4	-	100,78	5	3,5	1	-	1	84,8	-	105	1	-	0,25	
	95	111	117,4	5	3,5	1,1	0,6	3,5	86	91	119	1	0,5	0,5	
85	99	117	121,95	5	3,5	1,1	0,6	3,5	91	95	124	1	0,5	0,5	

¹⁾ Permissible axial displacement from the normal position of one bearing ring relative to the other.

²⁾ Recommended shaft abutment diameter for axially loaded bearings → *Flange support*, page 598.

5.4 Double row full complement cylindrical roller bearings d 90 – 150 mm

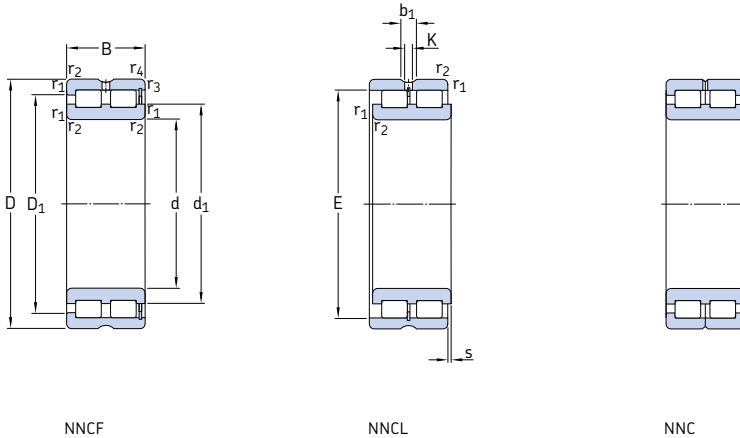

Principal dimensions			Basic load ratings		Fatigue load limit	Speed ratings		Mass	Designation
d	D	B	dynamic	static		Reference speed	Limiting speed		
mm			C	C ₀	P _u	r/min		kg	–
90	125	35	161	300	35,5	2 400	3 000	1,35	NNCF 4918 CV
	125	35	161	300	35,5	2 400	3 000	1,35	NNC 4918 CV
	125	35	161	300	35,5	2 400	3 000	1,3	NNCL 4918 CV
	140	67	369	560	69,5	2 200	2 800	3,6	NNCF 5018 CV
100	140	40	209	400	46,5	2 000	2 600	1,95	NNCF 4920 CV
	140	40	209	400	46,5	2 000	2 600	1,95	NNC 4920 CV
	140	40	209	400	46,5	2 000	2 600	1,9	NNCL 4920 CV
	150	67	391	620	75	2 000	2 600	3,95	NNCF 5020 CV
110	150	40	220	430	49	1 900	2 400	2,1	NNCF 4922 CV
	150	40	220	430	49	1 900	2 400	2,15	NNC 4922 CV
	150	40	220	430	49	1 900	2 400	2,1	NNCL 4922 CV
	170	80	512	800	95	1 800	2 200	6,3	NNCF 5022 CV
120	165	45	242	480	53	1 700	2 200	2,9	NNCF 4924 CV
	165	45	242	480	53	1 700	2 200	2,95	NNC 4924 CV
	165	45	242	480	53	1 700	2 200	2,85	NNCL 4924 CV
	180	80	539	880	104	1 700	2 000	6,75	NNCF 5024 CV
130	180	50	275	530	60	1 600	2 000	3,9	NNCF 4926 CV
	180	50	275	530	60	1 600	2 000	3,95	NNC 4926 CV
	180	50	275	530	60	1 600	2 000	3,8	NNCL 4926 CV
	200	95	765	1 250	143	1 500	1 900	10	NNCF 5026 CV
140	190	50	286	570	63	1 500	1 900	4,15	NNCF 4928 CV
	190	50	286	570	63	1 500	1 900	4,2	NNC 4928 CV
	190	50	286	570	63	1 500	1 900	4,1	NNCL 4928 CV
	210	95	809	1 370	156	1 400	1 800	11	NNCF 5028 CV
150	190	40	255	585	60	1 500	1 800	2,8	NNCF 4830 CV
	190	40	255	585	60	1 500	1 800	2,9	NNC 4830 CV
	190	40	255	585	60	1 500	1 800	2,7	NNCL 4830 CV
	210	60	429	830	91,5	1 400	1 700	6,55	NNCF 4930 CV
	210	60	429	830	91,5	1 400	1 700	6,65	NNC 4930 CV
	210	60	429	830	91,5	1 400	1 700	6,45	NNCL 4930 CV
	225	100	842	1 430	160	1 300	1 700	13,5	NNCF 5030 CV

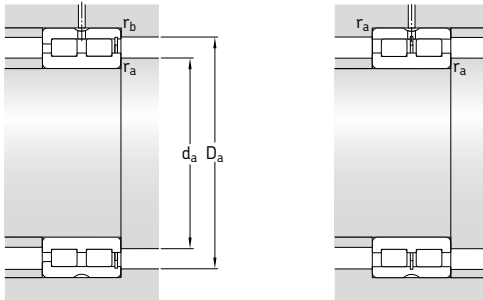

Dimensions										Abutment and fillet dimensions					Calculation factor
d	d ₁	D ₁	E	b ₁	K	r _{1,2} min.	r _{3,4} min.	s ¹⁾	d _a min.	d _{as} ²⁾	D _a max.	r _a max.	r _b max.	k _r	
mm										mm					-
90	103	111	115,2	5	3,5	1,1	1,1	1,5	95,4	99	119	1	1	0,25	
	103	111	115,2	5	3,5	1,1	-	-	95,4	99	119	1	-	0,25	
	103	-	115,2	5	3,5	1,1	-	1,5	95,4	-	119	1	-	0,25	
	106	124	130,65	5	3,5	1,5	1	4	98	102	133	1,5	1	0,5	
100	116	125	129,6	5	3,5	1,1	1,1	2	106	111	134	1	1	0,25	
	116	125	129,6	5	3,5	1,1	-	-	106	111	134	1	-	0,25	
	116	-	129,6	5	3,5	1,1	-	2	106	-	134	1	-	0,25	
	115	134	140,2	6	3,5	1,5	1	4	108	113	143	1,5	1	0,5	
110	125	134	138,2	6	3,5	1,1	1,1	2	116	121	144	1	1	0,25	
	125	134	138,2	6	3,5	1,1	-	-	116	121	144	1	-	0,25	
	125	-	138,2	6	3,5	1,1	-	2	116	-	144	1	-	0,25	
	127	149	156,7	6	3,5	2	1	5	120	124	161	2	1	0,5	
120	139	149	153,55	6	3,5	1,1	1,1	3	126	136	159	1	1	0,25	
	139	149	153,55	6	3,5	1,1	-	-	126	133	159	1	-	0,25	
	139	-	153,55	6	3,5	1,1	-	3	126	-	159	1	-	0,25	
	138	161	168,15	6	3,5	2	1	5	130	130	171	2	1	0,5	
130	149	160	165,4	6	3,5	1,5	1,5	4	138	144	173	1,5	1,5	0,25	
	149	160	165,4	6	3,5	1,5	-	-	138	144	173	1,5	-	0,25	
	149	-	165,4	6	3,5	1,5	-	4	138	-	173	1,5	-	0,25	
	149	175	184,4	7	4	2	1	5	141	145	190	2	1	0,5	
140	160	171	175,9	6	3,5	1,5	1,5	4	148	154	182	1,5	1,5	0,25	
	160	171	175,9	6	3,5	1,5	-	-	148	154	182	1,5	-	0,25	
	160	-	175,9	6	3,5	1,5	-	4	148	-	182	1,5	-	0,25	
	163	189	198,4	7	4	2	1	5	151	157	200	2	1	0,5	
150	165	174	178,3	7	4	1,1	1,1	2	156	161	184	1	1	0,2	
	165	174	178,3	7	4	1,1	-	-	156	161	184	1	-	0,2	
	165	-	178,3	7	4	1,1	-	2	156	-	184	1	-	0,2	
	171	187	192,77	7	4	2	2	4	159	165	201	2	2	0,25	
171	187	192,77	7	4	2	-	-	159	165	201	2	-	0,25		
171	-	192,77	7	4	2	-	4	159	-	201	2	-	0,25		
170	198	207,45	7	4	2	1,1	6	160	166	217	2	1	0,5		

¹⁾ Permissible axial displacement from the normal position of one bearing ring relative to the other.

²⁾ Recommended shaft abutment diameter for axially loaded bearings → *Flange support*, page 598.

5.4 Double row full complement cylindrical roller bearings d 160 – 190 mm

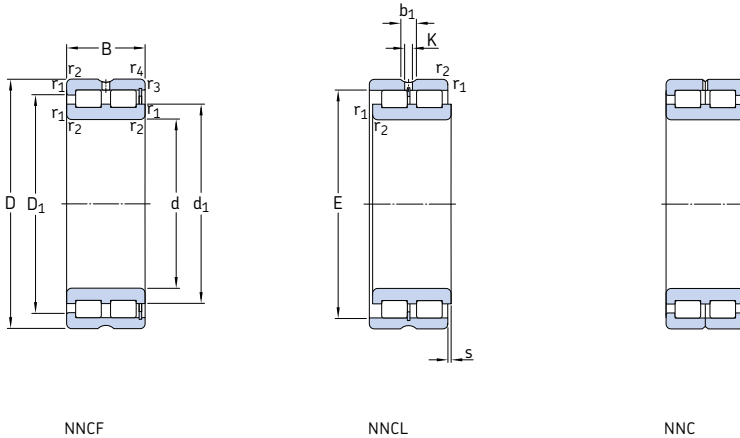

Principal dimensions	Basic load ratings		Fatigue load limit	Speed ratings		Mass	Designation		
	dynamic	static		Reference speed	Limiting speed				
d	D	B	C	C ₀	P _u				
mm			kN		kN	r/min	kg	–	
160	200	40	260	610	62	1 400	1 700	3	NNCF 4832 CV
	200	40	260	610	62	1 400	1 700	3,1	NNC 4832 CV
	200	40	260	610	62	1 400	1 700	2,9	NNCL 4832 CV
	220	60	446	915	96,5	1 300	1 600	6,9	NNCF 4932 CV
	220	60	446	915	96,5	1 300	1 600	7	NNC 4932 CV
	220	60	446	915	96,5	1 300	1 600	6,8	NNCL 4932 CV
170	240	109	952	1 600	180	1 200	1 500	16	NNCF 5032 CV
	215	45	286	655	65,5	1 300	1 600	4	NNCF 4834 CV
	215	45	286	655	65,5	1 300	1 600	4,1	NNC 4834 CV
	215	45	286	655	65,5	1 300	1 600	3,9	NNCL 4834 CV
	230	60	457	950	100	1 200	1 500	7,2	NNCF 4934 CV
	230	60	457	950	100	1 200	1 500	7,35	NNC 4934 CV
180	230	60	457	950	100	1 200	1 500	7,1	NNCL 4934 CV
	260	122	1 230	2 120	236	1 100	1 400	23	NNCF 5034 CV
	225	45	297	695	69,5	1 200	1 500	4,2	NNCF 4836 CV
	225	45	297	695	69,5	1 200	1 500	4,3	NNC 4836 CV
	225	45	297	695	69,5	1 200	1 500	4,1	NNCL 4836 CV
	250	69	594	1 220	127	1 100	1 400	10,5	NNCF 4936 CV
190	250	69	594	1 220	127	1 100	1 400	11	NNC 4936 CV
	250	69	594	1 220	127	1 100	1 400	10,5	NNCL 4936 CV
	280	136	1 420	2 500	270	1 100	1 300	30,5	NNCF 5036 CV
	240	50	330	750	76,5	1 100	1 400	5,5	NNCF 4838 CV
	240	50	330	750	76,5	1 100	1 400	5,65	NNC 4838 CV
	240	50	330	750	76,5	1 100	1 400	5,3	NNCL 4838 CV
190	260	69	605	1 290	132	1 100	1 400	11	NNCF 4938 CV
	260	69	605	1 290	132	1 100	1 400	11	NNC 4938 CV
	260	69	605	1 290	132	1 100	1 400	11	NNCL 4938 CV
	290	136	1 470	2 600	280	1 000	1 300	31,5	NNCF 5038 CV

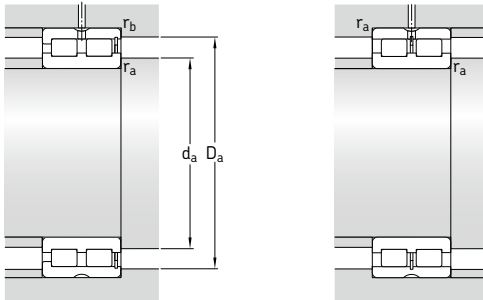

Dimensions							Abutment and fillet dimensions					Calculation factor		
d	d ₁	D ₁	E	b ₁	K	r _{1,2} min.	r _{3,4} min.	s ¹⁾	d _a min.	d _{as} ²⁾	D _a max.	r _a max.	r _b max.	k _r
mm									mm					-
160	174	182	186,9	7	4	1,1	1,1	2	166	170	194	1	1	0,2
	174	182	186,9	7	4	1,1	-	-	166	170	194	1	-	0,2
	174	-	186,9	7	4	1,1	-	2	166	-	194	1	-	0,2
	184	200	206,16	7	4	2	2	4	170	177	211	2	2	0,25
	184	200	206,16	7	4	2	-	-	170	177	211	2	-	0,25
	184	-	206,16	7	4	2	-	4	170	-	211	2	-	0,25
184	216	224,8	7	4	2,1	1,1	6	171	178	231	2	1	0,5	
170	187	197	201,3	7	4	1,1	1,1	3	176	182	209	1	1	0,2
	187	197	201,3	7	4	1,1	-	-	176	182	209	1	-	0,2
	187	-	201,3	7	4	1,1	-	3	176	-	209	1	-	0,2
	193	209	215,08	7	4	2	2	4	180	187	220	2	2	0,25
	193	209	215,08	7	4	2	-	-	180	187	220	2	-	0,25
	193	-	215,08	7	4	2	-	4	180	-	220	2	-	0,25
198	232	243	7	4	2,1	1,1	6	181	193	251	2	1	0,5	
180	200	210	214,1	7	4	1,1	1,1	3	186	193	219	1	1	0,2
	200	210	214,1	7	4	1,1	-	-	186	193	219	1	-	0,2
	200	-	214,1	7	4	1,1	-	3	186	-	219	1	-	0,2
	205	224	230,5	7	4	2	2	4	190	198	240	2	2	0,25
	205	224	230,5	7	4	2	-	-	190	198	240	2	-	0,25
	205	-	230,5	7	4	2	-	4	190	-	240	2	-	0,25
212	249	260,5	8	4	2,1	2,1	8	191	206	270	2	2	0,5	
190	209	221	225	7	4	1,5	1,5	4	197	203	233	1,5	1,5	0,2
	209	221	225	7	4	1,5	-	-	197	203	233	1,5	-	0,2
	209	-	225	7	4	1,5	-	4	197	-	233	1,5	-	0,2
	215	234	240,7	7	4	2	2	4	201	208	250	2	2	0,25
	215	234	240,7	7	4	2	-	-	201	208	250	2	-	0,25
	215	-	240,7	7	4	2	-	4	201	-	250	2	-	0,25
222	258	270	8	4	2,1	2,1	8	202	216	280	2	2	0,5	

¹⁾ Permissible axial displacement from the normal position of one bearing ring relative to the other.

²⁾ Recommended shaft abutment diameter for axially loaded bearings → *Flange support*, page 598.

5.4 Double row full complement cylindrical roller bearings d 200 – 260 mm

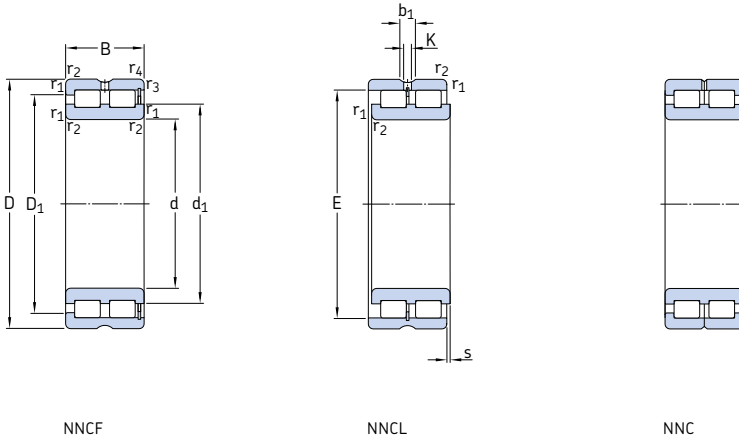

Principal dimensions	Basic load ratings		Fatigue load limit	Speed ratings		Mass	Designation		
	dynamic	static		Reference speed	Limiting speed				
d	D	B	C	C ₀	P _u				
mm			kN		kN	r/min	kg	–	
200	250	50	336	800	80	1 100	1 400	5,8	NNCF 4840 CV
	250	50	336	800	80	1 100	1 400	5,9	NNC 4840 CV
	250	50	336	800	80	1 100	1 400	5,7	NNCL 4840 CV
	280	80	704	1 500	153	1 000	1 300	15,5	NNCF 4940 CV
	280	80	704	1 500	153	1 000	1 300	16	NNC 4940 CV
	280	80	704	1 500	153	1 000	1 300	15,5	NNCL 4940 CV
220	310	150	1 680	3 050	320	950	1 200	41	NNCF 5040 CV
	270	50	352	865	85	1 000	1 200	6,3	NNCF 4844 CV
	270	50	352	865	85	1 000	1 200	6,4	NNC 4844 CV
	270	50	352	865	85	1 000	1 200	6,2	NNCL 4844 CV
	300	80	737	1 600	160	950	1 200	17	NNCF 4944 CV
	300	80	737	1 600	160	950	1 200	17	NNC 4944 CV
240	300	80	737	1 600	160	950	1 200	17	NNCL 4944 CV
	340	160	2 010	3 600	375	850	1 100	52,5	NNCF 5044 CV
	300	60	539	1 290	125	900	1 100	9,9	NNCF 4848 CV
	300	60	539	1 290	125	900	1 100	10	NNC 4848 CV
	300	60	539	1 290	125	900	1 100	9,8	NNCL 4848 CV
	320	80	781	1 760	173	850	1 100	18,5	NNCF 4948 CV
260	320	80	781	1 760	173	850	1 100	18,5	NNC 4948 CV
	320	80	781	1 760	173	850	1 100	18	NNCL 4948 CV
	360	160	2 120	3 900	400	800	1 000	56	NNCF 5048 CV
	320	60	561	1 400	132	800	1 000	11	NNCF 4852 CV
	320	60	561	1 400	132	800	1 000	11	NNC 4852 CV
	320	60	561	1 400	132	800	1 000	10,5	NNCL 4852 CV
360	100	1 170	2 550	245	750	950	31,5	NNCF 4952 CV	
	360	100	1 170	2 550	245	750	950	32	NNC 4952 CV
	360	100	1 170	2 550	245	750	950	31	NNCL 4952 CV
	400	190	2 860	5 100	500	700	900	85,5	NNCF 5052 CV

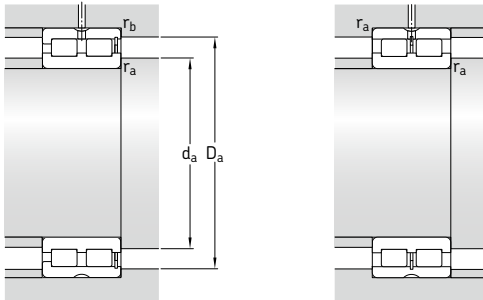

Dimensions							Abutment and fillet dimensions					Calculation factor		
d	d ₁	D ₁	E	b ₁	K	r _{1,2} min.	r _{3,4} min.	s ¹⁾	d _a min.	d _{as} ²⁾	D _a max.	r _a max.	r _b max.	k _r
mm														
200	219	231	235,5	7	4	1,5	1,5	4	207	213	243	1,5	1,5	0,2
	219	231	235,5	7	4	1,5	-	-	207	213	243	1,5	-	0,2
	219	-	235,5	7	4	1,5	-	4	207	-	243	1,5	-	0,2
	230	252	259,34	8	4	2,1	2,1	5	211	219	269	2	2	0,25
	230	252	259,34	8	4	2,1	-	-	211	221	269	2	-	0,25
	230	-	259,34	8	4	2,1	-	5	211	-	269	2	-	0,25
236	276	288	8	4	2,1	2,1	9	212	224	300	2	2	0,5	
220	239	252	256,5	7	4	1,5	1,5	4	227	233	263	1,5	1,5	0,2
	239	252	256,5	7	4	1,5	-	-	227	233	263	1,5	-	0,2
	239	-	256,5	7	4	1,5	-	4	227	-	263	1,5	-	0,2
	248	269	276,52	8	4	2,1	2,1	5	232	240	288	2	2	0,25
	248	269	276,52	8	4	2,1	-	-	232	240	288	2	-	0,25
	248	-	276,52	8	4	2,1	-	5	232	-	288	2	-	0,25
255	300	312,2	8	6	3	3	9	235	245	327	2,5	2,5	0,5	
240	259	277	281,9	8	4	2	2	4	249	254	292	2	2	0,2
	259	277	281,9	8	4	2	-	-	249	254	292	2	-	0,2
	259	-	281,9	8	4	2	-	4	249	-	292	2	-	0,2
	270	292	299,46	8	4	2,1	2,1	5	251	261	308	2	2	0,25
	270	292	299,46	8	4	2,1	-	-	251	261	308	2	-	0,25
	270	-	299,46	8	4	2,1	-	5	251	-	308	2	-	0,25
278	322	335,6	9,4	5	3	3	9	256	267	347	2,5	2,5	0,5	
260	282	299	304,2	8	4	2	2	4	269	276	311	2	2	0,2
	282	299	304,2	8	4	2	-	-	269	276	311	2	-	0,2
	282	-	304,2	8	4	2	-	4	269	-	311	2	-	0,2
	294	322	331,33	9,4	5	2,1	2,1	6	272	283	349	2	2	0,25
	294	322	331,33	9,4	5	2,1	-	-	272	283	349	2	-	0,25
	294	-	331,33	9,4	5	2,1	-	6	272	-	349	2	-	0,25
304	357	373,5	9,4	5	4	4	10	278	291	384	3	3	0,5	

¹⁾ Permissible axial displacement from the normal position of one bearing ring relative to the other.

²⁾ Recommended shaft abutment diameter for axially loaded bearings → *Flange support*, page 598.

5.4 Double row full complement cylindrical roller bearings d 280 – 340 mm

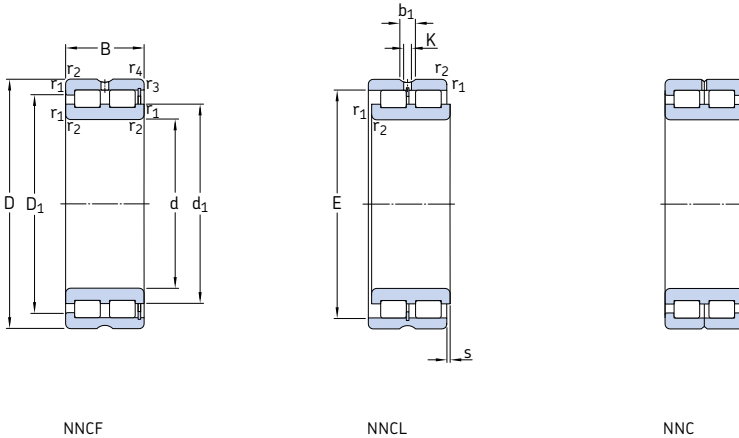

Principal dimensions	Basic load ratings		Fatigue load limit	Speed ratings		Mass	Designation		
	dynamic	static		Reference speed	Limiting speed				
d	D	B	C	C ₀	P _u				
mm			kN		kN	r/min.	kg	–	
280	350	69	737	1 860	173	750	950	16	NNCF 4856 CV
	350	69	737	1 860	173	750	950	16	NNC 4856 CV
	350	69	737	1 860	173	750	950	15,5	NNCL 4856 CV
	380	100	1 210	2 700	255	700	900	33,5	NNCF 4956 CV
	380	100	1 210	2 700	255	700	900	34	NNC 4956 CV
	380	100	1 210	2 700	255	700	900	33	NNCL 4956 CV
300	420	190	2 920	5 300	520	670	850	90,5	NNCF 5056 CV
	380	80	858	2 120	196	700	850	22,5	NNCF 4860 CV
	380	80	858	2 120	196	700	850	23	NNC 4860 CV
	380	80	858	2 120	196	700	850	22	NNCL 4860 CV
	420	118	1 680	3 750	355	670	800	52,5	NNCF 4960 CV
	420	118	1 680	3 750	355	670	800	53	NNC 4960 CV
320	420	118	1 680	3 750	355	670	800	52	NNCL 4960 CV
	460	218	3 250	6 550	600	600	750	130	NNCF 5060 CV
	400	80	897	2 280	208	630	800	23,5	NNCF 4864 CV
	400	80	897	2 280	208	630	800	24	NNC 4864 CV
	400	80	897	2 280	208	630	800	23	NNCL 4864 CV
	440	118	1 760	4 050	375	600	750	55,5	NNCF 4964 CV
340	440	118	1 760	4 050	375	600	750	56	NNC 4964 CV
	440	118	1 760	4 050	375	600	750	55	NNCL 4964 CV
	480	218	3 690	6 950	620	560	700	135	NNCF 5064 CV
	420	80	913	2 400	216	600	750	25	NNCF 4868 CV
	420	80	913	2 400	216	600	750	25,5	NNC 4868 CV
	420	80	913	2 400	216	600	750	25,5	NNCL 4868 CV
340	460	118	1 790	4 250	390	560	700	58,5	NNCF 4968 CV
	460	118	1 790	4 250	390	560	700	59	NNC 4968 CV
	460	118	1 790	4 250	390	560	700	58	NNCL 4968 CV
	520	243	4 400	8 300	710	530	670	185	NNCF 5068 CV

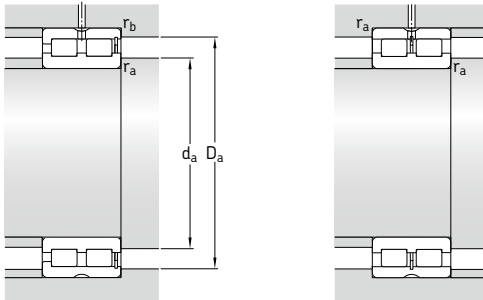

Dimensions										Abutment and fillet dimensions					Calculation factor
d	d ₁	D ₁	E	b ₁	K	b _{1,2} min.	r _{3,4} min.	s ¹⁾	d _a min.	d _{as} ²⁾	D _a max.	r _a max.	r _b max.	k _r	
mm										mm					-
280	307	326	332,4	8	4	2	2	4	290	299	341	2	2	0,2	
	307	326	332,4	8	4	2	-	-	290	299	341	2	-	0,2	
	307	-	332,4	8	4	2	-	4	290	-	341	2	-	0,2	
	316	345	353,34	9,4	5	2,1	2,1	6	293	312	368	2	2	0,25	
	316	345	353,34	9,4	5	2,1	-	-	293	305	368	2	-	0,25	
	316	-	353,34	9,4	5	2,1	-	6	293	-	368	2	-	0,25	
	320	372	389	9,4	5	4	4	10	299	310	404	3	3	0,5	
	300	328	350	356,7	9,4	5	2,1	2,1	6	310	319	370	2	2	0,2
		328	350	356,7	9,4	5	2,1	-	-	310	319	370	2	-	0,2
328		-	356,7	9,4	5	2,1	-	6	310	-	370	2	-	0,2	
341		374	385,51	9,4	5	3	3	6	315	335	406	2,5	2,5	0,25	
341		374	385,51	9,4	5	3	-	-	315	328	406	2,5	-	0,25	
341		-	385,51	9,4	5	3	-	6	315	-	406	2,5	-	0,25	
352		418	433	9,4	5	4	4	9	319	336	443	3	3	0,5	
320		351	373	379,7	9,4	5	2,1	2,1	6	331	341	390	2	2	0,2
		351	373	379,7	9,4	5	2,1	-	-	331	341	390	2	-	0,2
	351	-	379,7	9,4	5	2,1	-	6	331	-	390	2	-	0,2	
	368	401	412,27	9,4	5	3	3	6	336	352	425	2,5	2,5	0,25	
	368	401	412,27	9,4	5	3	-	-	336	352	425	2,5	-	0,25	
	368	-	412,27	9,4	5	3	-	6	336	-	425	2,5	-	0,25	
	370	434	449	9,4	5	4	4	9	339	360	462	3	3	0,5	
	340	368	390	396,9	9,4	5	2,1	2,1	6	351	360	410	2	2	0,2
		368	390	396,9	9,4	5	2,1	-	-	351	360	410	2	-	0,2
368		-	396,9	9,4	5	2,1	-	6	351	-	410	2	-	0,2	
385		419	430,11	9,4	5	3	3	6	356	371	445	2,5	2,5	0,25	
385		419	430,11	9,4	5	3	-	-	356	371	445	2,5	-	0,25	
385		-	430,11	9,4	5	3	-	6	356	-	445	2,5	-	0,25	
395		468	485	9,4	5	5	5	11	362	384	500	4	4	0,5	

¹⁾ Permissible axial displacement from the normal position of one bearing ring relative to the other.

²⁾ Recommended shaft abutment diameter for axially loaded bearings → *Flange support*, page 598.

5.4 Double row full complement cylindrical roller bearings d 360 – 400 mm

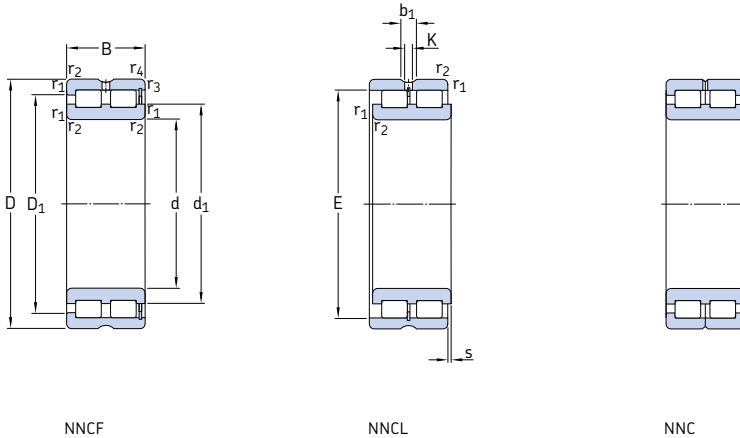

Principal dimensions	Basic load ratings		Fatigue load limit	Speed ratings		Mass	Designation		
	dynamic	static		Reference speed	Limiting speed				
d	D	B	C	C ₀	P _u				
mm			kN		kN	r/min	kg	–	
360	440	80	935	2 550	224	560	700	26,5	NNCF 4872 CV
	440	80	935	2 550	224	560	700	27	NNC 4872 CV
	440	80	935	2 550	224	560	700	26	NNCL 4872 CV
	480	118	1 830	4 500	405	530	670	61,5	NNCF 4972 CV
	480	118	1 830	4 500	405	530	670	62	NNC 4972 CV
	480	118	1 830	4 500	405	530	670	61	NNCL 4972 CV
380	540	243	4 460	8 650	735	500	630	195	NNCF 5072 CV
	480	100	1 400	3 650	315	530	670	45	NNCF 4876 CV
	480	100	1 400	3 650	315	530	670	45,5	NNC 4876 CV
	480	100	1 400	3 650	315	530	670	44	NNCL 4876 CV
	520	140	2 380	5 700	500	500	630	91,5	NNCF 4976 CV
	520	140	2 380	5 700	500	500	630	92,5	NNC 4976 CV
400	520	140	2 380	5 700	500	500	630	90,5	NNCL 4976 CV
	560	243	4 680	9 150	735	480	600	200	NNCF 5076 CV
	500	100	1 420	3 750	325	500	630	46	NNCF 4880 CV
	500	100	1 420	3 750	325	500	630	46,5	NNC 4880 CV
	500	100	1 420	3 750	325	500	630	46	NNCL 4880 CV
	540	140	2 420	6 000	520	480	600	95,5	NNCF 4980 CV
540	140	2 420	6 000	520	480	600	96,5	NNC 4980 CV	
540	140	2 420	6 000	520	480	600	94,5	NNCL 4980 CV	
600	272	5 500	11 000	900	450	560	270	NNCF 5080 CV	

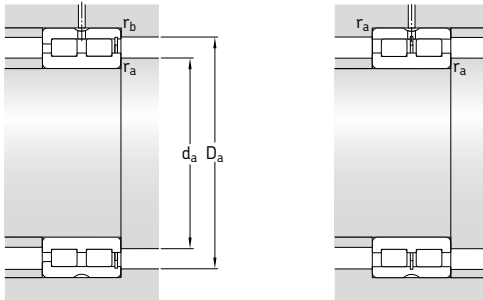

Dimensions							Abutment and fillet dimensions					Calculation factor		
d	d ₁	D ₁	E	b ₁	K	r _{1,2} min.	r _{3,4} min.	s ¹⁾	d _a min.	d _{as} ²⁾	D _a max.	r _a max.	r _b max.	k _r
mm														
360	391	413	419,8	9,4	5	2,1	2,1	6	371	381	429	2	2	0,2
	391	413	419,8	9,4	5	2,1	-	-	371	381	429	2	-	0,2
	391	-	419,8	9,4	5	2,1	-	6	371	-	429	2	-	0,2
	404	437	447,95	9,4	5	3	3	6	375	390	464	2,5	2,5	0,25
	404	437	447,95	9,4	5	3	-	-	375	390	464	2,5	-	0,25
	404	-	447,95	9,4	5	3	-	6	375	-	464	2,5	-	0,25
412	486	503	9,4	5	5	5	11	383	402	519	4	4	0,5	
380	419	447	455,8	9,4	5	2,1	2,1	6	391	405	469	2	2	0,2
	419	447	455,8	9,4	5	2,1	-	-	391	405	469	2	-	0,2
	419	-	455,8	9,4	5	2,1	-	6	391	-	469	2	-	0,2
	430	469	481,35	9,4	5	4	4	7	398	414	502	3	3	0,25
	430	469	481,35	9,4	5	4	-	-	398	414	502	3	-	0,25
	430	-	481,35	9,4	5	4	-	7	398	-	502	3	-	0,25
431	504	521	9,4	5	5	5	11	403	417	539	4	4	0,5	
400	434	462	470,59	9,4	5	2,1	2,1	6	411	423	488	2	2	0,2
	434	462	470,59	9,4	5	2,1	-	-	411	423	488	2	-	0,2
	434	-	470,59	9,4	5	2,1	-	6	411	-	488	2	-	0,2
	451	489	501,74	9,4	5	4	4	7	418	435	521	3	3	0,25
	451	489	501,74	9,4	5	4	-	-	418	435	521	3	-	0,25
	451	-	501,74	9,4	5	4	-	7	418	-	521	3	-	0,25
460	540	558	9,4	5	5	5	11	424	442	578	4	4	0,5	

¹⁾ Permissible axial displacement from the normal position of one bearing ring relative to the other.

²⁾ Recommended shaft abutment diameter for axially loaded bearings → *Flange support*, page 598.

5.5 Sealed double row full complement cylindrical roller bearings d 20 – 110 mm

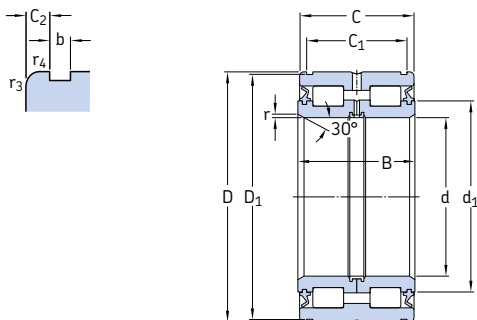

Principal dimensions				Basic load ratings		Fatigue load limit	Limiting speed	Mass	Designation
d	D	B	C	dynamic	static				
				C	C ₀	P _u			
mm				kN		kN	r/min.	kg	–
20	42	30	29	45,7	55	5,7	3 400	0,2	NNF 5004 ADB-2LSV
25	47	30	29	50,1	65,5	6,8	3 000	0,24	NNF 5005 ADB-2LSV
30	55	34	33	57,2	75	7,8	2 600	0,37	NNF 5006 ADB-2LSV
35	62	36	35	70,4	98	10,6	2 200	0,48	NNF 5007 ADB-2LSV
40	68	38	37	85,8	116	13,2	2 000	0,56	NNF 5008 ADB-2LSV
45	75	40	39	102	146	17	1 800	0,7	NNF 5009 ADB-2LSV
50	80	40	39	108	160	18,6	1 700	0,76	NNF 5010 ADB-2LSV
55	90	46	45	128	193	22,8	1 500	1,2	NNF 5011 ADB-2LSV
60	95	46	45	134	208	25	1 400	1,25	NNF 5012 ADB-2LSV
65	100	46	45	138	224	26,5	1 300	1,35	NNF 5013 ADB-2LSV
70	110	54	53	187	285	34,5	1 200	1,85	NNF 5014 ADB-2LSV
75	115	54	53	205	310	40	1 100	1,95	NNF 5015 ADB-2LSV
80	125	60	59	251	415	53	1 000	2,7	NNF 5016 ADA-2LSV
85	130	60	59	270	430	55	1 000	2,85	NNF 5017 ADA-2LSV
90	140	67	66	319	550	69,5	900	3,7	NNF 5018 ADA-2LSV
95	145	67	66	330	570	71	900	3,9	NNF 5019 ADA-2LSV
100	150	67	66	336	570	68	850	3,95	NNF 5020 ADA-2LSV
110	170	80	79	413	695	81,5	750	6,45	NNF 5022 ADA-2LSV

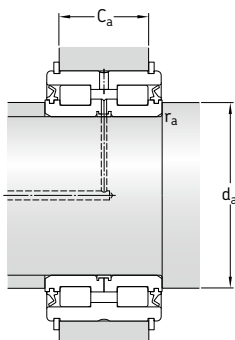

Dimensions								Abutment and fillet dimensions ¹⁾					Calcula- tion factor k_f	Appropriate snap rings ²⁾ Designations Seeger DIN 471	
d	d ₁ ~	D ₁ ~	C ₁ +0,2	C ₂	b	r min.	r _{3,4} min.	d _a min.	d _{as} ³⁾	C _{a1} -0,2	C _{a2} -0,2	r _a max.		-	-
mm													-	-	
20	30,6	40,2	24,7	2,15	1,8	0,5	0,3	24	28,8	21,5	21	0,3	0,4	SW 42	42x1,75
25	35,4	45,2	24,7	2,15	1,8	0,5	0,3	29	33,6	21,5	21	0,3	0,4	SW 47	47x1,75
30	40,6	53	28,2	2,4	2,1	0,5	0,3	34	38,7	25	24	0,3	0,4	SW 55	55x2
35	46,1	60	30,2	2,4	2,1	0,5	0,3	39	44	27	26	0,3	0,4	SW 62	62x2
40	51,4	65,8	32,2	2,4	2,7	0,8	0,6	44	49,2	28	27	0,4	0,4	SW 68	68x2,5
45	57	72,8	34,2	2,4	2,7	0,8	0,6	49	54,7	30	29	0,4	0,4	SW 75	75x2,5
50	61,8	77,8	34,2	2,4	2,7	0,8	0,6	54	59,5	30	29	0,4	0,4	SW 80	80x2,5
55	68,6	87,4	40,2	2,4	3,2	1	0,6	60	66,1	35	34	0,6	0,4	SW 90	90x3
60	73,7	92,4	40,2	2,4	3,2	1	0,6	65	71,2	35	34	0,6	0,4	SW 95	95x3
65	78,8	97,4	40,2	2,4	3,2	1	0,6	70	76,3	35	34	0,6	0,4	SW 100	100x3
70	84,5	108	48,2	2,4	4,2	1	0,6	75	82	43	40	0,6	0,4	SW 110	110x4
75	90	113	48,2	2,4	4,2	1	0,6	80	87	43	40	0,6	0,4	SW 115	115x4
80	97	123	54,2	2,4	4,2	1,5	0,6	86	94,3	49	46	1	0,4	SW 125	125x4
85	101	128	54,2	2,4	4,2	1,5	0,6	91	100	49	46	1	0,4	SW 130	130x4
90	109	137	59,2	3,4	4,2	1,5	0,6	96	106	54	51	1	0,4	SW 140	140x4
95	113	142	59,2	3,4	4,2	1,5	0,6	101	110	54	51	1	0,4	SW 145	145x4
100	118	147	59,2	3,4	4,2	1,5	0,6	106	115	54	51	1	0,4	SW 150	150x4
110	132	167	70,2	4,4	4,2	1,8	0,6	117	128	65	62	1,5	0,4	SW 170	170x4

¹⁾ The values for C_{a1} apply for SW snap rings, the values for C_{a2} for snap rings in accordance with DIN 471.

²⁾ Snap rings must be ordered separately. They are not supplied by SKF.

³⁾ Recommended shaft abutment diameter for axially loaded bearings → *Flange support*, page 598.

5.5 Sealed double row full complement cylindrical roller bearings d 120 – 240 mm

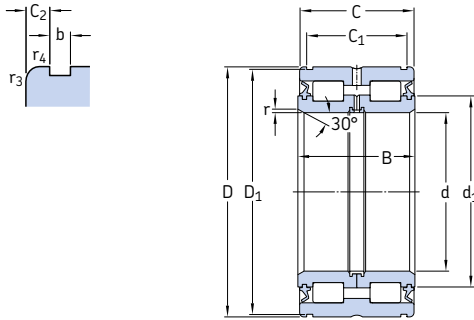

Principal dimensions				Basic load ratings		Fatigue load limit	Limiting speed	Mass	Designation
d	D	B	C	dynamic	static				
mm	mm	mm	mm	C	C ₀	P _u	r/min.	kg	–
120	180	80	79	429	750	86,5	700	6,9	NNF 5024 ADA-2LSV
130	190	80	79	446	815	91,5	670	7,5	319426 DA-2LS
	200	95	94	616	1 040	120	630	10,5	NNF 5026 ADA-2LSV
140	200	80	79	468	865	96,5	630	8	319428 DA-2LS
	210	95	94	644	1 120	127	600	11	NNF 5028 ADA-2LSV
150	210	80	79	468	900	96,5	560	8,4	319430 DA-2LS
	225	100	99	748	1 290	143	560	13,5	NNF 5030 ADA-2LSV
160	220	80	79	501	1 000	106	530	8,8	319432 DA-2LS
	240	109	108	781	1 400	153	500	16,5	NNF 5032 ADA-2LSV
170	230	80	79	512	1 060	110	530	9,3	319434 DA-2LS
	260	122	121	1 010	1 800	193	480	22,5	NNF 5034 ADA-2LSV
180	240	80	79	528	1 100	114	500	9,8	319436 DA-2LS
	280	136	135	1 170	2 120	228	450	30	NNF 5036 ADA-2LSV
190	260	80	79	550	1 180	120	450	12,5	319438 DA-2LS
	290	136	135	1 190	2 200	236	430	31,5	NNF 5038 ADA-2LSV
200	270	80	79	561	1 250	125	430	13	319440 DA-2LS
	310	150	149	1 450	2 900	300	400	42	NNF 5040 ADA-2LSV
220	340	160	159	1 610	3 100	315	360	53,5	NNF 5044 ADA-2LSV
240	360	160	159	1 680	3 350	335	340	57,5	NNF 5048 ADA-2LSV

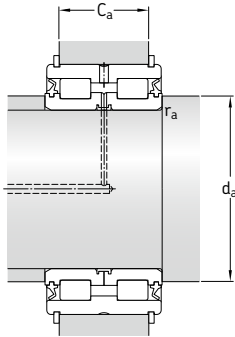

Dimensions							Abutment and fillet dimensions ¹⁾						Calcula- tion factor k_f	Appropriate snap rings ²⁾ Designations Seeger DIN 471
d	d_1 ~	D_1 ~	C_1 +0,2	C_2	b	r min.	$r_{3,4}$ min.	d_a min.	d_{as} ³⁾	C_{a1} -0,2	C_{a2} -0,2	r_a max.		
mm													-	-
120	141	176	71,2	3,9	4,2	1,8	0,6	127	138	65	63	1,5	0,4	SW180 180x4
130	151 155	186 196	71,2 83,2	3,9 5,4	4,2 4,2	1,8 1,8	0,6 0,6	137 137	147 150	65 77	63 75	1,5 1,5	0,4 0,4	SW190 190x4 SW200 200x4
140	160 167	196 206	71,2 83,2	3,9 5,4	4,2 5,2	1,8 1,8	0,6 0,6	147 147	156 162	65 77	63 73	1,5 1,5	0,4 0,4	SW200 200x4 SW210 210x5
150	175 177	206 221	71,2 87,2	3,9 5,9	5,2 5,2	1,8 2	0,6 0,6	157 157	171 172	65 81	61 77	1,5 2	0,4 0,4	SW210 210x5 SW225 225x5
160	184 191	216 236	71,2 95,2	3,9 6,4	5,2 5,2	1,8 2	0,6 0,6	167 167	180 186	65 89	61 85	1,5 2	0,4 0,4	SW220 220x5 SW240 240x5
170	194 203	226 254	71,2 107,2	3,9 6,9	5,2 5,2	1,8 2	0,6 0,6	177 177	190 197	65 99	61 97	1,5 2	0,4 0,4	SW230 230x5 SW260 260x5
180	203 220	236 274	71,2 118,2	3,9 8,4	5,2 5,2	1,8 2	0,6 0,6	177 187	199 214	65 110	61 108	1,5 2	0,4 0,4	SW240 240x5 SW280 280x5
190	218 228	254 284	73,2 118,2	2,9 8,4	5,2 5,2	1,8 2	0,6 0,6	197 197	214 222	65 110	63 108	1,5 2	0,4 0,4	SW260 260x5 SW290 290x5
200	227 245	264 304	73,2 128,2	2,9 10,4	5,2 6,3	1,8 2	0,6 0,6	207 207	223 239	65 120	63 116	1,5 2	0,4 0,4	SW270 270x5 SW310 310x6
220	263	334	138,2	10,4	6,3	2	1	227	256	130	126	2	0,4	SW340 340x6
240	282	354	138,2	10,4	6,3	2	1	247	275	130	126	2	0,4	SW360 360x6

¹⁾ The values for C_{a1} apply for SW snap rings, the values for C_{a2} for snap rings in accordance with DIN 471.

²⁾ Snap rings must be ordered separately. They are not supplied by SKF.

³⁾ Recommended shaft abutment diameter for axially loaded bearings → *Flange support*, page 598.



6 Needle roller bearings

Designs and variants	674	Permissible speed.	714
Needle roller and cage assemblies	674	Design of bearing arrangements	714
Basic design bearings	675	Abutment dimensions	714
Other needle roller and cage assemblies	675	Shaft and housing tolerances	716
Drawn cup needle roller bearings	677	Mounting	718
with open ends	678	Designation system	720
with a closed end	678	Product tables	
full complement	678	6.1 Needle roller and cage assemblies	722
Arrangements with components and other bearings	679	6.2 Drawn cup needle roller bearings	730
Needle roller bearings with machined rings	680	Needle roller bearings with machined rings	
with flanges	681	6.3 with flanges, without an inner ring	744
without flanges	682	6.4 with flanges, with an inner ring	758
Arrangements with other bearings	682	6.5 without flanges, without an inner ring	770
Alignment needle roller bearings	683	6.6 without flanges, with an inner ring	774
Combined needle roller bearings	683	Alignment needle roller bearings	
Needle roller /		6.7 without an inner ring	776
angular contact ball bearings	684	6.8 with an inner ring	778
thrust ball bearings	685	6.9 Needle roller / angular contact ball bearings	780
cylindrical roller thrust bearings	689	6.10 Needle roller / thrust ball bearings, full complement thrust bearing	784
Needle roller bearing components	691	6.11 Needle roller / thrust ball bearings, thrust bearing with a cage	786
Needle roller bearing inner rings	691	6.12 Needle roller / cylindrical roller thrust bearings	788
Needle rollers	692	6.13 Needle roller bearing inner rings	790
Cages	693	6.14 Needle rollers	794
Sealing solutions	696	Other needle roller bearings	
Greases for capped bearings	698	Bearings with Solid Oil	1185
Relubrication facilities	699	NoWear coated bearings	1241
Bearing data	701	Universal joint bearings	→ skf.com/bearings
(Dimension standards, tolerances, operating clearance, internal clearance, misalignment)			
Loads	711		
(Minimum load, equivalent loads, safety load factor)			
Temperature limits.	714		



Designs and variants

SKF needle roller bearings are bearings with cylindrical rollers that are small in diameter relative to their length. The ends of the rollers are relieved slightly to modify the line contact between the rollers and raceways. This prevents stress peaks at the roller ends to extend bearing service life. In spite of their low cross section, needle roller bearings have a high load carrying capacity. Therefore, they are extremely suitable for bearing arrangements where radial space is limited. SKF supplies needle roller bearings in many different designs, series and in a wide range of sizes, which make them appropriate for a wide variety of operating conditions and applications.

Needle roller and cage assemblies

SKF needle roller and cage assemblies are ready-to-mount, self-contained bearings. They are an excellent choice for applications that require a very rigid bearing arrangement as well as a high load carrying capacity. If the shaft and housing bore can serve as raceways, needle roller and cage assemblies require minimal radial space.

More information

Bearing life and load ratings	63
Design considerations	159
Bearing systems	160
Abutment and fillet dimensions	208
Lubrication	239
Mounting, dismounting and bearing care	271

Basic design bearings

SKF basic design needle roller and cage assemblies are identified by the series designation K and available in single row (no designation suffix) and double row (designation suffix ZW) designs (→ **fig. 1**). They are characterized by the following properties:

- simple and rugged design
- accurate roller guidance in the cage pockets
- good running performance

Other needle roller and cage assemblies

On request, SKF also supplies needle roller and cage assemblies in other sizes or different designs.

Needle roller and cage assemblies with a split cage can be used where raceways are recessed in the shaft (→ **fig. 2**).

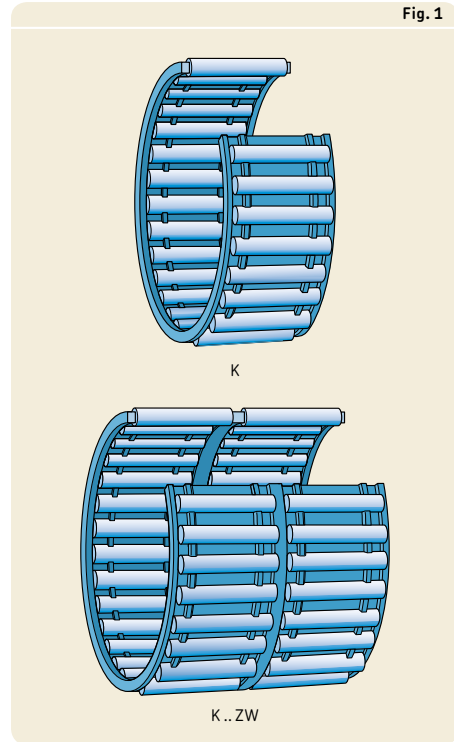

6

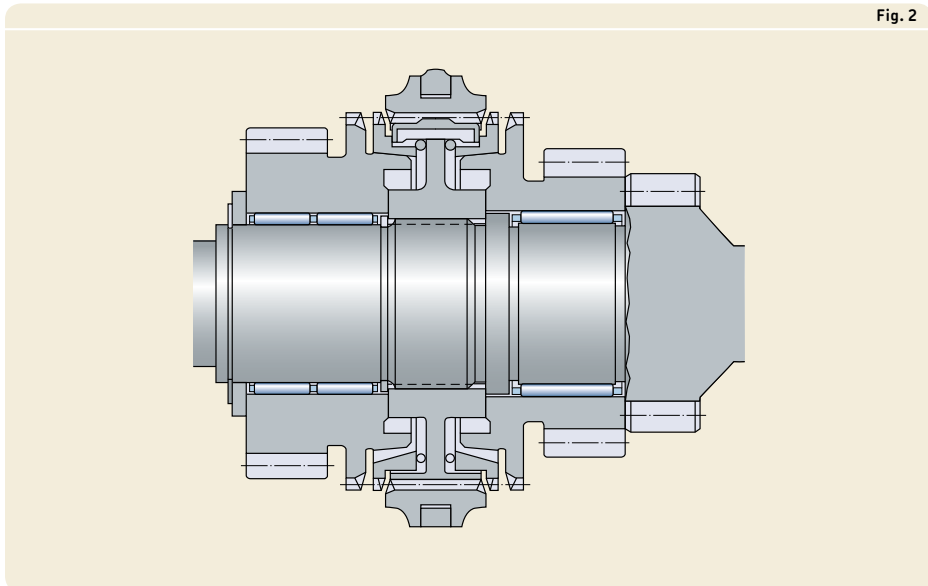

6 Needle roller bearings

Special needle roller and cage assemblies for the gudgeon (wrist) pin (→ **fig. 3**) and crank pin (crankshaft journal) (→ **fig. 4**) for connecting rods of internal combustion engines and compressors, provide excellent service in spite of rapid accelerations, elevated temperatures, unfavourable load or poor lubrication conditions.

For additional information about special sizes and designs of needle roller and cage assemblies, contact the SKF application engineering service.

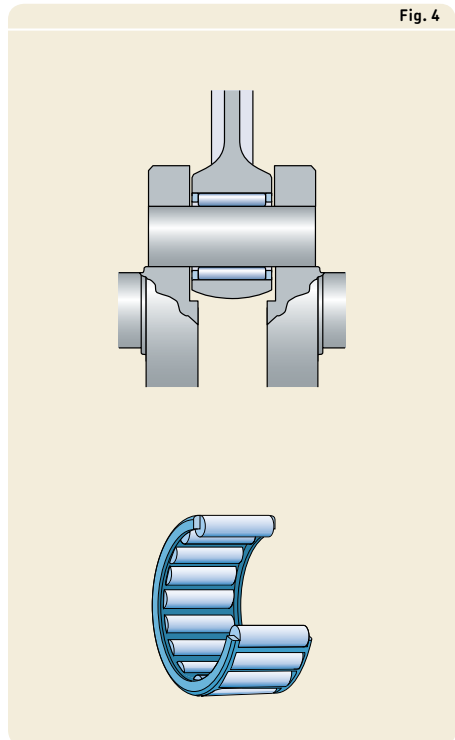
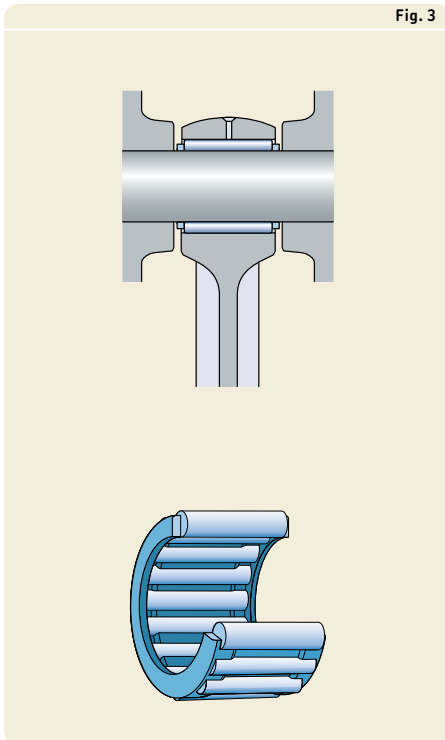

Drawn cup needle roller bearings

SKF drawn cup needle roller bearings have a deep drawn, thin-walled outer ring. They are characterized by a very low sectional height and high load carrying capacity. Drawn cup needle roller bearings are typically used in applications where the housing bore cannot be used as a raceway for a needle roller and cage assembly, but where a very compact and economical bearing arrangement is required. These bearings are mounted with a tight interference fit in the housing. That enables a simple and economic design of the housing bore, as shoulders or snap rings are not required to locate the bearing axially.

The drawn cup of hardened steel and the needle roller and cage assembly of these bearings form a non-separable unit.

SKF supplies a wide assortment of drawn cup needle roller bearings. This includes:

- drawn cup needle roller bearings with open ends (→ **fig. 5**)
- drawn cup needle roller bearings with a closed end (→ **fig. 6**)
- full complement drawn cup needle roller bearings with open ends (→ **fig. 7**)

Fig. 5

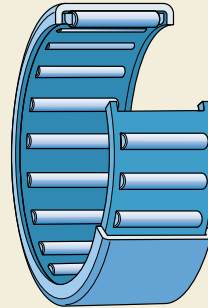

HK

Fig. 6

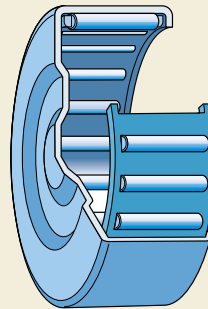

BK

Fig. 7

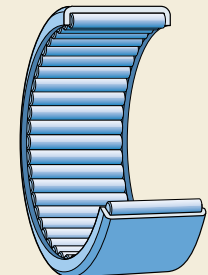

HN

6 Needle roller bearings

SKF supplies all drawn cup needle roller bearings without an inner ring. These bearings are generally designed with one needle roller and cage assembly. However, wide sizes incorporate two needle roller and cage assemblies immediately adjacent to each other, with a lubrication hole in the outer ring (→ **fig. 8**). The double row bearings are not identified by any designation suffix but are marked in the product tables by a footnote.

Drawn cup needle roller bearings with open ends

SKF drawn cup needle roller bearings with open ends (→ **fig. 5, page 677**) are identified by the series designation HK. They are available open (without seals) or sealed on one or both sides (→ *Sealing solutions, page 696*).

Drawn cup needle roller bearings with a closed end

SKF drawn cup needle roller bearings with a closed end (→ **fig. 6, page 677**) are identified by the series designation BK. They are available open or sealed (→ *Sealing solutions, page 696*) and are suitable for bearing arrangements at the end of a shaft. The profiled design of the closed end accommodates small axial guidance forces.

Full complement drawn cup needle roller bearings

SKF full complement drawn cup needle roller bearings (→ **fig. 7, page 677**) are identified by the series designation HN. They are suitable for very heavy radial loads at moderate speeds and are available with open ends and without seals only.

Fig. 8

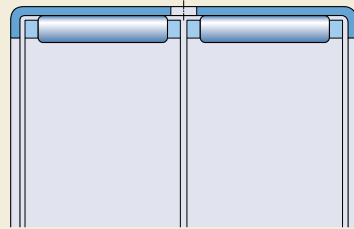

HK (double row)

Greases for full complement drawn cup bearings

Full complement drawn cup needle roller bearings are supplied with a special grease to secure the rollers during transport. However, SKF recommends relubricating after mounting, as this grease does not provide sufficient long term lubrication. Depending on the required consistency class, SKF recommends SKF LGEP 2 or SKF LGMW 1 grease for relubrication. The technical specifications of the initial grease fill and the relubrication greases are listed in **table 1**.

Arrangements with components and other bearings

Generally, drawn cup needle roller bearings run directly on a shaft. However, in applications where the shaft cannot be hardened and ground, bearings should be combined with an inner ring (→ **fig. 9**). Wide inner rings can also provide an excellent counterface for the lips of external G or SD design seals (→ skf.com/seals). For additional information about inner rings, refer to *Needle roller bearing inner rings* (→ **page 691**).

To accommodate combined radial and axial loads, certain sizes of drawn cup needle roller bearings can be combined with a needle roller thrust bearing with a centring flange, AXW series (→ **fig. 10**). For additional information, refer to *Needle roller thrust bearings* (→ **page 1057**).

Fig. 9

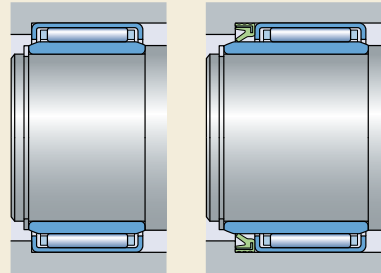

With a standard inner ring

With a wide inner ring and an external seal

Fig. 10

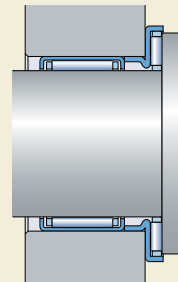

Table 1

Technical specifications of SKF standard greases for full complement drawn cup needle roller bearings

Grease	Temperature range ¹⁾							Thickener	Base oil type	NLGI consistency class	Base oil viscosity [mm ² /s]	
	-50	0	50	100	150	200	250				at 40 °C (105 °F)	at 100 °C (210 °F)
Initial grease fill								Lithium soap	Mineral	1-2	200	18,7
LGEP 2								Lithium soap	Mineral	2	200	16
LGMW 1								Lithium soap	Mineral	1	200	16

¹⁾ Refer to the SKF traffic light concept → **page 244**

6 Needle roller bearings

Needle roller bearings with machined rings

SKF needle roller bearings with machined rings are made of carbon chromium bearing steel. Relative to their low sectional height, they have a high load carrying capacity. SKF supplies needle roller bearings with machined rings with (→ **fig. 11**) or without flanges (→ **fig. 12**) on the outer ring, in a wide range of series and sizes. SKF also supplies these bearings with or without an inner ring.

Needle roller bearings with machined inner and outer rings

Needle roller bearings with an inner ring (→ **fig. 12**) are used for applications where the shaft cannot be hardened and ground. The permissible axial displacement (→ **product tables**) of the shaft relative to the housing is limited for bearings with an inner ring. If the permissible axial displacement provided by a standard inner ring is insufficient, it is possible to use an extended inner ring (→ *Needle roller bearing inner rings*, **page 691**).

Needle roller bearings with a machined outer ring, without an inner ring

Needle roller bearings without an inner ring (→ **fig. 11**) are an excellent choice for compact bearing arrangements if the shaft can be hardened and ground. Eliminating the need for a separate inner ring enables a larger shaft diameter and a stiffer bearing arrangement. Axial displacement of the shaft relative to the housing is only limited by the width of the raceway on the shaft. By machining the shaft raceways to the appropriate dimensional and geometrical accuracy, it is possible to obtain bearing arrangements with heightened running accuracy. For additional information, refer to *Raceways on shafts and in housings* (→ **page 210**).

Fig. 11

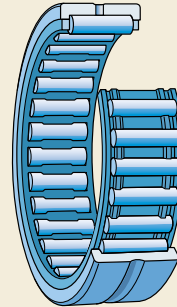
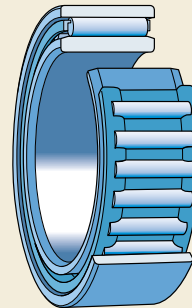

Fig. 12



Needle roller bearings with machined rings, with flanges

SKF needle roller bearings with flanges on the outer ring are available open (without seals) or sealed (→ *Sealing solutions*, page 696) on one or both sides and with or without an inner ring. Bearings with an outside diameter $D \leq 17$ mm ($F_w \leq 10$ mm), are available with non-separable closure rings that act as flanges (→ **fig. 13**). The flanges on larger bearings are an integral part of the outer ring, and the bearings have an annular groove and one or more lubrication holes in the outer ring (→ **fig. 14**). With the exception of RNA 69 (→ **fig. 15**) and NA 69 series double row bearings with an outside diameter $D \geq 52$ mm ($F_w \geq 40$ mm), needle roller bearings with flanges are generally designed as single row bearings.

The roller and cage assembly and outer ring of a needle roller bearing with flanges form a non-separable unit.

Fig. 13

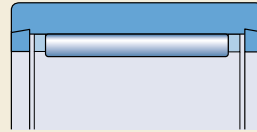

NK ($F_w \leq 10$ mm)

Fig. 14

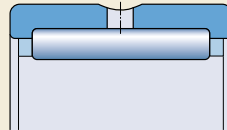

NK ($F_w \geq 12$ mm)
 NKS
 RNA 48
 RNA 49
 RNA 69 ($F_w \leq 35$ mm)

Fig. 15

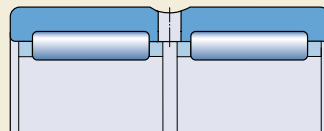

RNA 69 ($F_w \geq 40$ mm)

6 Needle roller bearings

Needle roller bearings with machined rings, without flanges

SKF needle roller bearings without flanges on the outer ring are separable, i.e. the outer ring, needle roller and cage assembly and inner ring, can all be mounted separately. Therefore, the needle roller and cage assembly can either be mounted together with the outer ring or with the shaft or inner ring, depending on the arrangement design. It can also be inserted between the outer ring and shaft or inner ring as the final step. However, needle roller and cage assemblies and bearing outer rings must always be kept together as supplied.

SKF needle roller bearings without flanges are generally designed with one needle roller and cage assembly (→ **fig. 12, page 680**). However, wide sizes incorporate two needle roller and cage assemblies immediately adjacent to each other and have an annular groove and a lubrication hole in the outer ring (→ **fig. 16**). The double row bearings are not identified by any designation suffix, but are marked in the product tables by a footnote.

Arrangements with other bearings

To accommodate combined radial and axial loads, needle roller bearings with machined rings can be combined with a needle roller thrust bearing with a centring flange, AXW series, if the outside diameter D of the radial bearing is equal to the flange diameter D_1 of the thrust bearing (→ **fig. 17**). For additional information, refer to *Needle roller thrust bearings* (→ **page 1057**).

Fig. 16

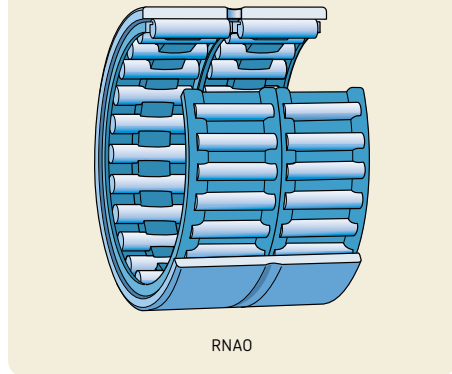
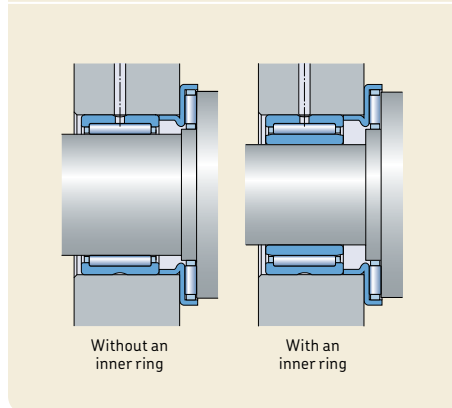

Fig. 17



Alignment needle roller bearings

SKF alignment needle roller bearings have an outer ring with a sphered (convex) outside surface. Two polymer seating rings with a sphered (concave) inside surface are encased in a drawn sheet steel sleeve and fitted over the outer ring. This design enables the bearing to accommodate static misalignment of the shaft relative to the housing. SKF supplies alignment needle roller bearings with or without an inner ring (→ **fig. 18**).

In applications where the shaft cannot be hardened and ground, bearings with an inner ring should be used. The permissible axial displacement (→ **product tables**) of the shaft relative to the housing is limited for bearings with an inner ring. If the permissible axial displacement provided by a standard inner ring is insufficient, it is possible to use an extended inner ring (→ *Needle roller bearing inner rings*, **page 691**).

Bearings without an inner ring are an excellent choice for compact bearing arrangements, if the shaft can be hardened and ground.

Combined needle roller bearings

SKF combined needle roller bearings consist of a radial needle roller bearing combined with a thrust bearing. They can accommodate both radial and axial loads. Combined needle roller bearings provide the means to design locating bearing arrangements where radial space is limited. They are particularly suitable for applications where other types of locating bearing arrangements occupy too much space, or where the axial loads are too heavy, the speeds are too high, or the lubricant is inadequate for arrangements with simple thrust washers. SKF supplies combined needle roller bearings in the following basic designs:

- needle roller / angular contact ball bearing
- needle roller / thrust ball bearing
- needle roller / cylindrical roller thrust bearing

Relubrication intervals for the radial and thrust part of the bearing must be calculated separately. The shorter of the two intervals should be used. For additional information about lubrication, refer to *Lubrication* (→ **page 239**).

6

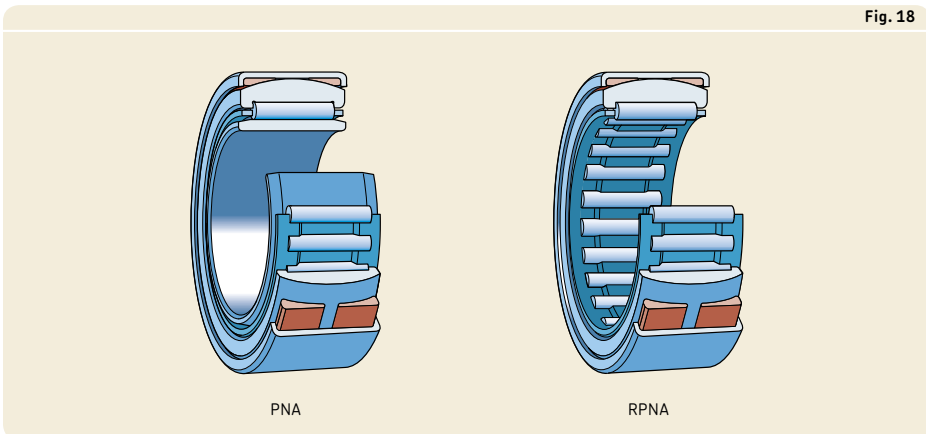

6 Needle roller bearings

Needle roller / angular contact ball bearings

SKF needle roller / angular contact ball bearings combine a radial needle roller bearing with an angular contact ball bearing. The radial loads are accommodated exclusively by the needle roller bearing and the axial loads exclusively by the angular contact ball bearing. These low cross section bearings can operate at high speeds and accommodate heavy radial and light axial loads. SKF supplies these bearings without seals in the following two series:

- NKIA series (→ **fig. 19**), bearings can accommodate axial loads in one direction
- NKIB series (→ **fig. 20**), bearings can accommodate axial loads in both directions

Bearings in both series are separable i.e. the inner ring can be mounted separately from the outer ring, rolling element and cage assemblies. However, the inner rings in the NKIB series are not interchangeable with those from another seemingly identical bearing. Therefore, the bearings must be kept together as supplied.

Depending on the application, needle roller / angular contact ball bearings can be grease or oil lubricated. In the case of grease lubrication, both the needle roller and angular contact ball bearing should be filled with the same lubricant prior to mounting.

Fig. 19

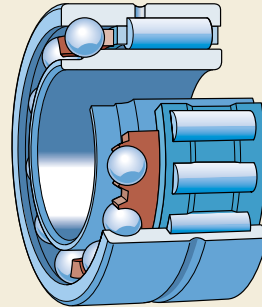

NKIA 59

Fig. 20

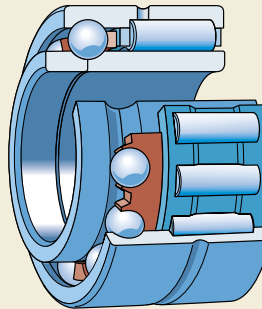

NKIB 59

Fig. 21

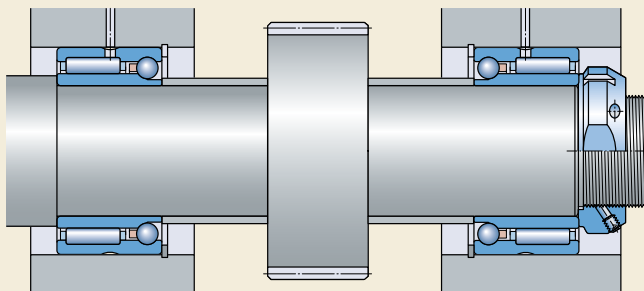

NKIA 59, back-to-back arrangement

NKIA series

Needle roller / angular contact ball bearings in the NKIA 59 series (→ **fig. 19**) can accommodate axial loads in one direction and can, therefore, locate the shaft in one direction only. For short shafts and where changes in length as a result of thermal expansion are relatively minor, two bearings in the NKIA 59 series can be mounted back-to-back (→ **fig. 21**).

NKIB series

Needle roller / angular contact ball bearings in the NKIB 59 series (→ **fig. 20**) can locate a shaft in both directions. The axial clearance is between 0,08 and 0,25 mm. To facilitate mounting, the bearing has a two-piece inner ring. When mounting the inner ring, it is important that the two pieces are mounted immediately adjacent to each other without any gap between them.

Needle roller / thrust ball bearings

SKF needle roller / thrust ball bearings combine a radial needle roller bearing and a thrust ball bearing. SKF supplies these bearings in the following two series:

- NX series (→ **fig. 22**), with a full complement thrust ball bearing
- NKX series (→ **fig. 23**), with a thrust ball bearing with a cage

Fig. 22

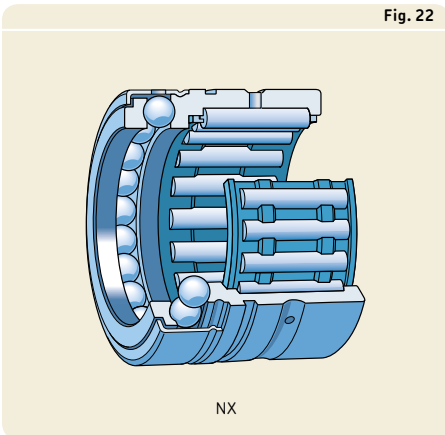
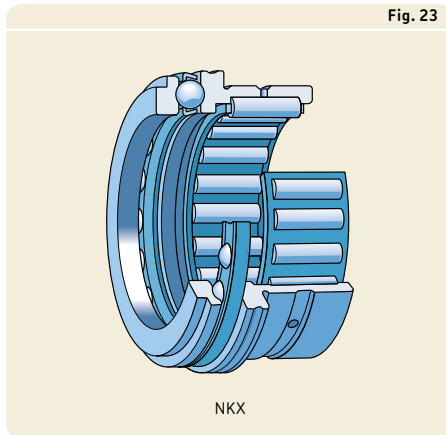

Fig. 23



6 Needle roller bearings

SKF supplies the bearings of both series without an inner ring. In applications where the shaft cannot be hardened and ground, the needle roller bearing can be combined with an inner ring (→ **fig. 24**). Appropriate inner rings are listed in the product tables and must be ordered separately.

Needle roller / thrust ball bearings can accommodate axial loads in one direction and can, therefore, locate the shaft in one direction only. For short shafts and where changes in length as a result of thermal expansion are relatively minor, two bearings can be mounted back-to-back (→ **fig. 25**). For these types of arrangements, SKF recommends elastically preloading the thrust ball bearings with cup springs (Belleville washers). This elastic preload helps to prevent the balls from skidding if one of the thrust bearings becomes unloaded. Preload also improves performance of the thrust ball bearings while reducing noise levels.

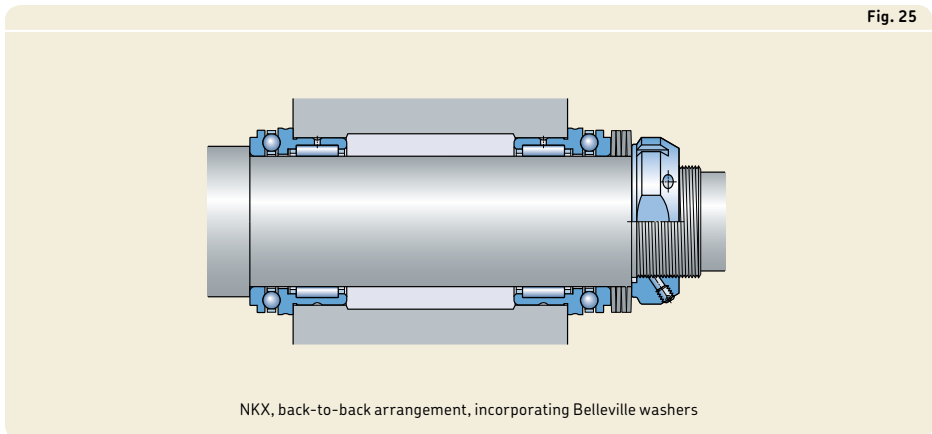
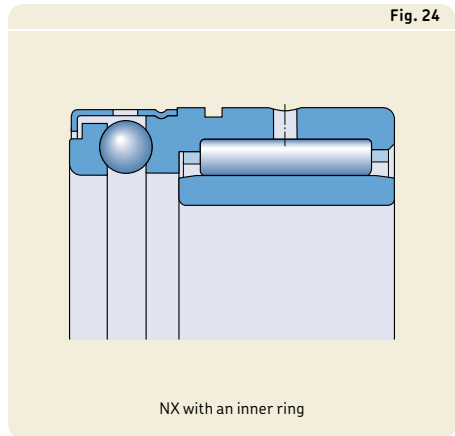

NX series

Needle roller / full complement thrust ball bearings in the NX series (→ **fig. 26**) are suitable for applications where there are moderate radial loads and lighter, single direction axial loads. Their extremely low sectional height enables shaft centrelines to be positioned close together like for multi-spindle drills. For axial support, the bearings can be mounted with a snap ring or against a shoulder in the housing bore. The snap ring groove in the outer ring provides a cost-effective and axially space-saving solution (→ **fig. 27**). The appropriate snap rings are listed in the product tables.

Needle roller / thrust ball bearings in the NX series have a stamped steel cover. It extends over the shaft washer of the thrust ball bearing and is firmly attached to the radial needle roller bearing. The cover makes these bearings non-separable. Most often they are oil lubricated, as the cover has lubrication holes. Therefore, SKF supplies these bearings without grease.

Needle roller / thrust ball bearings in the NX series with the designation suffix Z (→ **fig. 28**) have a stamped steel cover without lubrication holes and should be grease lubricated.

Fig. 26

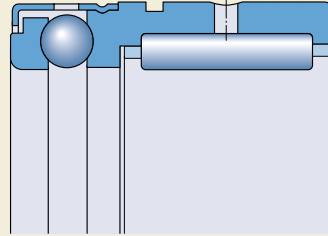

NX

6

Fig. 27

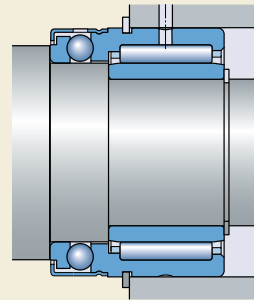

NX mounted with a snap ring

Fig. 28

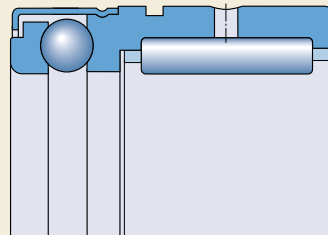

NX..Z

6 Needle roller bearings

NKX series

Needle roller / thrust ball bearings in the NKX series combine a radial needle roller bearing and a thrust ball bearing with a ball and cage thrust assembly identical to the 511 series. They permit relatively high-speed operation. The outer ring flange locates the bearings axially in one direction.

Needle roller / thrust ball bearings in the NKX series (→ **fig. 29**) do not have a cover over the thrust ball bearing. Therefore, both the ball and cage assembly and shaft washer can be mounted separately from the rest of the bearing. These bearings, without the designation suffix Z, should be oil lubricated whenever possible, as there is no cover that retains the grease in the bearing.

Needle roller / thrust ball bearings in the NKX series with the designation suffix Z (→ **fig. 30**) have a stamped steel cover without lubrication holes. The steel cover extends over the shaft washer of the thrust ball bearing. It is firmly attached to the housing washer that is integral to the needle roller bearing outer ring. The cover makes these bearings non-separable.

Fig. 29

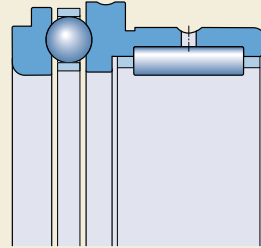

NKX

Fig. 30

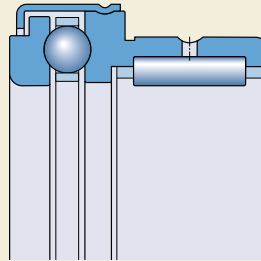

NKX..Z

Needle roller / cylindrical roller thrust bearings

SKF needle roller / cylindrical roller thrust bearings in the NKXR series (→ **fig. 31**) combine a radial needle roller bearing and a cylindrical roller thrust bearing. The cylindrical roller and cage thrust assembly is identical to the 811 series. These combined bearings are supplied without an inner ring. In applications where the shaft cannot be hardened and ground, bearings can be combined with an inner ring (→ **fig. 32**). Appropriate inner rings are listed in the product tables and must be ordered separately.

Needle roller / cylindrical roller thrust bearings in the NKXR series are separable. Both the cylindrical roller and cage thrust assembly and shaft washer can be mounted separately from the rest of the bearing. These bearings, without the designation suffix Z, should be oil lubricated whenever possible, as oil facilitates an adequate supply of lubricant to the bearing.

Needle roller / cylindrical roller thrust bearings with the designation suffix Z (→ **fig. 33**) have a stamped steel cover without lubrication holes. The steel cover extends over the shaft washer of the cylindrical roller thrust bearing. It is firmly attached to the housing washer that is integral to the needle roller bearing outer ring. The cover makes these bearings non-separable.

Fig. 31

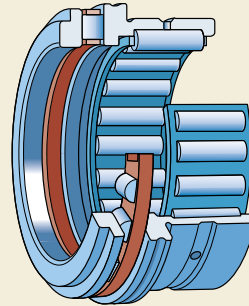

NKXR

Fig. 32

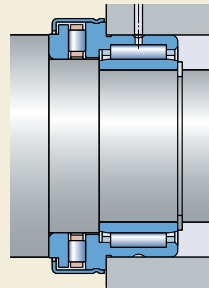
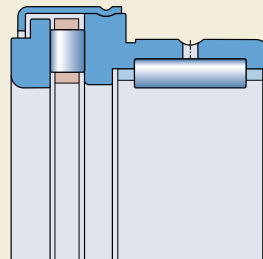

Fig. 33



NKXR..Z

6 Needle roller bearings

Needle roller / cylindrical roller thrust bearings can accommodate axial loads in one direction and can, therefore, locate the shaft in one direction only. For short shafts and where changes in length as a result of thermal expansion are relatively minor, two bearings can be mounted back-to-back (→ **fig. 34**). For these types of arrangements, SKF recommends elastically preloading the roller thrust bearings with cup springs (Belleveille washers). This elastic preload helps to prevent the rollers from skidding if one of the thrust bearings becomes unloaded. Preload also improves the performance of the bearings while reducing noise levels.

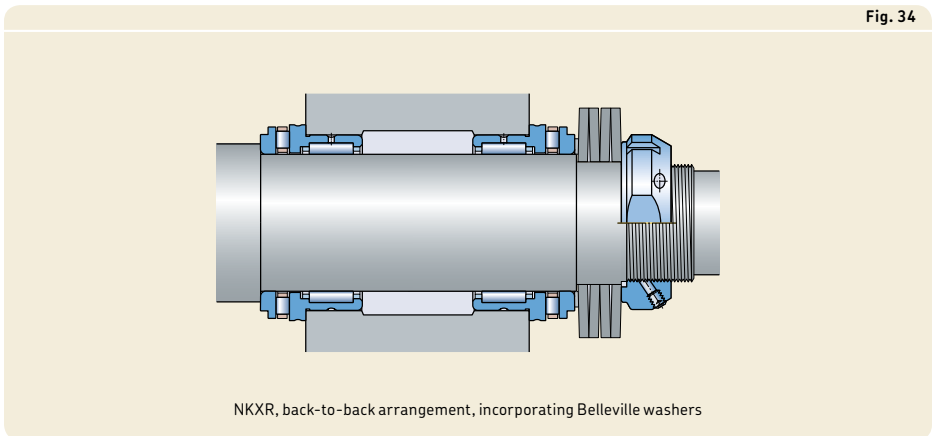

Fig. 34

NKXR, back-to-back arrangement, incorporating Belleville washers

Needle roller bearing components

Needle roller bearing inner rings

SKF supplies inner rings for needle roller bearings separately. They are typically combined with needle roller and cage assemblies or drawn cup needle roller bearings in applications where the shaft cannot be hardened and ground. Inner rings are available in the following two series:

- IR series (→ **fig. 35**), with or without a lubrication hole, with or without a machining allowance
- LR series (→ **fig. 36**)

Inner rings in both series are also available in different widths. Wide inner rings permit greater axial displacement of the shaft, relative to the housing, when compared to standard width inner rings. They also provide an excellent counterface for the lips of contact seals (→ **fig. 9, page 679**).

Regardless of whether the ring has an interference or loose fit, it should be located on both sides to prevent axial movement. One side can be located against a shoulder. The other side can be located by either a snap ring, a distance ring or a nut.

IR series

IR series inner rings, (→ **fig. 35**) the standard SKF inner rings for needle roller bearings, are made of carbon chromium bearing steel. The rings are hardened and ground. The raceway surface is precision ground, and has a lead-in chamfer on both sides. The chamfers facilitate assembly and protect the seal lips from damage during the mounting process.

Fig. 35

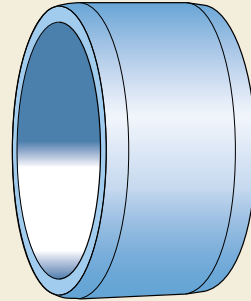

IR

Fig. 36

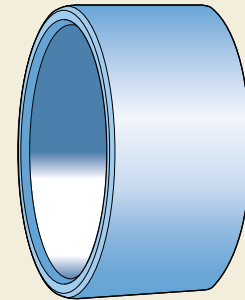

LR

6 Needle roller bearings

Some sizes of IR inner rings have a lubrication hole (→ **fig. 37**). They are identified by the designation suffix IS1. Inner rings with additional lubrication holes are available on request.

Also on request, SKF supplies inner rings in the IR series with a pre-ground raceway and a machining allowance z . These inner rings are identified by the designation suffix VGS. The machining allowance depends on the inner ring raceway diameter and is listed in **table 2**. They can be finish ground after mounting on a shaft in applications where extremely high running accuracy is required.

LR series

Inner rings in the LR series (→ **fig. 36**, **page 691**) are made of carbon chromium bearing steel. The rings are hardened, and the bore and raceway diameter are ground. The side faces are turned and the edges are smoothed. For applications where the larger run-out and width tolerances are less important, these inner rings can be used to provide a cost-effective bearing arrangement.

Needle rollers

SKF needle rollers are made of carbon chromium steel. The rollers have a hardness of 58 to 65 HRC and have a precision ground surface. They can be used to design full complement bearing arrangements for slow-speed or oscillating applications. These compact bearing arrangements have a very high load carrying capacity when compared to bearings with a cage and are economical, provided the shaft and housing bore can serve as raceways (→ *Raceways on shafts and in housings*, **page 210**).

For assistance in designing full complement bearing arrangements or to calculate performance data for these bearing arrangements, contact the SKF application engineering service.

Fig. 37

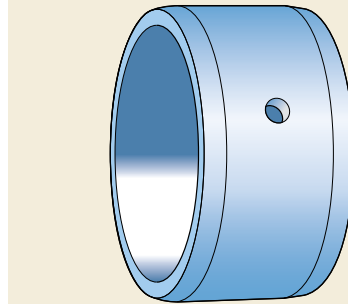

IR .. IS1

Table 2

Machining allowance of inner ring raceway diameter

Raceway diameter F		Machining allowance z	Preground raceway diameter F _{VGS}
over	incl.		
mm		mm	mm
–	50	0,10	F _{VGS} = F + z (tolerance class h7(Ⓜ))
50	80	0,15	
80	180	0,20	
180	250	0,25	
250	315	0,30	
315	400	0,35	
400	500	0,40	

Cages

Depending on their design, series and size, SKF needle roller bearings are fitted with one of the cages shown in **table 3** (→ **page 694**). The standard cage is not identified in the bearing designation.

The lubricants generally used for rolling bearings do not have a detrimental effect on cage properties. However, some synthetic oils and greases with a synthetic oil base and lubricants containing a high proportion of EP additives, when used at high temperatures, can have a detrimental effect on polyamide cages. For additional information about the suitability of cages, refer to *Cages* (→ **page 37**) and *Cage materials* (→ **page 152**).

Double row needle roller bearings

Double row needle roller and cage assemblies have a double row cage in the same design as a single row cage (→ **fig. 1, page 675**).

Other double row needle roller bearings are equipped with two cage assemblies (→ **fig. 15, page 681** and **fig. 16, page 682**).

6 Needle roller bearings

Cages for needle roller bearings

Cages for radial bearings

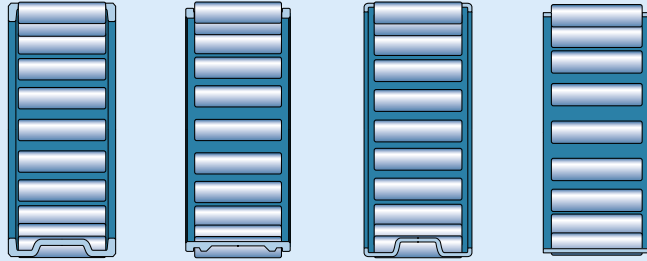

Cage characteristics

Cage type	Window-type	Window-type	Window-type	Window-type
Material	Sheet steel or machined steel	Sheet steel or machined steel	Sheet steel	Sheet steel
Suffix	-	-	-	-
Bearing types				
Needle roller and cage assemblies	Standard	-	Standard	-
Drawn cup needle roller bearings	-	-	-	Standard
Needle roller bearings with machined rings	-	Standard	-	-
Alignment needle roller bearings	-	Standard	-	-
Needle roller / angular contact ball bearing	-	Standard	-	-
Needle roller / thrust ball bearing	-	Standard	-	-
Needle roller / cylindrical roller thrust bearing	-	Standard	-	-

Table 3

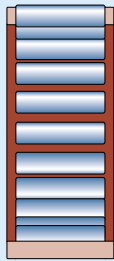
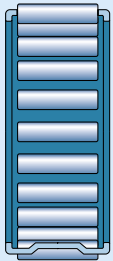

Cages for thrust bearings



Window-type	Window-type	Window-type	Snap-type	Window-type
Sheet steel or machined steel	Glass fibre reinforced PA66	Sheet steel	Glass fibre reinforced PA66	Glass fibre reinforced PA66
-	TN	-	-	-
-	Standard	-	-	-
-	Standard	-	-	-
Standard	Standard	-	-	-
Standard	-	-	-	-
Standard	-	-	Standard	-
Standard	Standard	Standard	-	-
Standard	-	-	-	Standard

6 Needle roller bearings

Sealing solutions

SKF supplies certain needle roller bearings capped with a seal or steel cover. The assortment of capped bearings includes the following types:

- drawn cup needle roller bearings, sealed on one or both sides
- needle roller bearings with machined rings in the (R)NA 49 series, sealed on one or both sides
- combined needle roller bearings with the designation suffix Z, steel cover over the thrust part of the bearing

SKF supplies capped bearings filled, as standard, with high-quality grease that has good corrosion inhibiting properties (→ *Greases for capped bearings*, page 698).

In addition to integral bearing seals, SKF also supplies an assortment of external seals that can be used for needle roller bearing arrangements. Appropriate power transmission seals are listed in the relevant product tables, when available. For information about these seals, refer to the product information, available online at skf.com/seals.

Sealed drawn cup needle roller bearings

For applications where a sufficiently effective seal is not available, or cannot be used for space reasons, SKF supplies certain drawn cup needle roller bearings as sealed bearings. They include:

- drawn cup needle roller bearings with open ends, sealed on one side, designation suffix RS (→ **fig. 38**), available for shaft diameters ranging from 8 to 50 mm
- drawn cup needle roller bearings with open ends, sealed on both sides, designation suffix .2RS (→ **fig. 39**), available for shaft diameters ranging from 8 to 50 mm
- sealed drawn cup needle roller bearings with a closed end, designation suffix RS (→ **fig. 40**), available for shaft diameters ranging from 10 to 25 mm

These integral contact seals are made of PUR, FKM or NBR. Sealed drawn cup needle roller bearings are, under normal conditions, an extremely cost-effective solution to exclude

Fig. 38

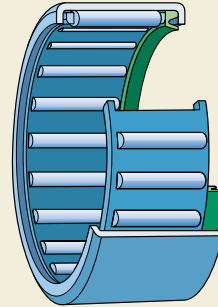

HK..RS

Fig. 39

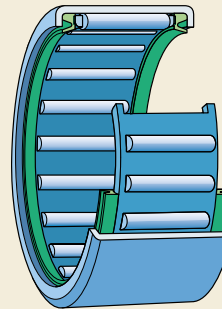

HK...2RS

Fig. 40

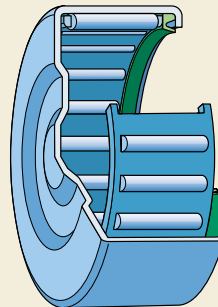

BK..RS

solid contaminants and moisture and retain the lubricant in the bearing.

Sealed needle roller bearings with machined rings

Needle roller bearings with machined rings in the (R)NA 49 series are available with a contact seal (→ **fig. 41**) on one or both sides. The NBR seals are effective at keeping the lubricant in and contaminants out of the bearing.

The inner ring of sealed bearings is 1 mm wider than the outer ring. This maintains the effectiveness of the seals and simplifies the bearing arrangements even when small axial displacements occur.

6

WARNING

Seals made of FKM (fluoro rubber) exposed to an open flame or temperatures above 300 °C (570 °F) are a health and environmental hazard! They remain dangerous even after they have cooled.

Read and follow the safety precautions under *Seal materials* (→ **page 155**).

Fig. 41

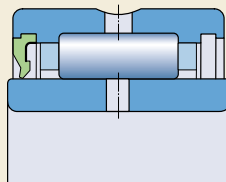

NA 49 ..RS

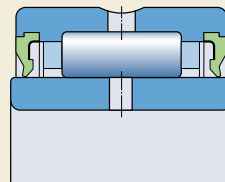

NA 49 ...2RS

6 Needle roller bearings

Combined needle roller bearings, designation suffix Z

Combined needle roller bearings with the designation suffix Z have a stamped steel cover over the thrust part of the bearing. The cover, which has no lubrication holes, forms a gap-type seal to retain the grease in the bearing. The bearings are available in the following basic designs and series:

- needle roller / thrust ball bearing, NX .. Z (→ **fig. 28, page 687**) and NKX .. Z (→ **fig. 30, page 688**) series
- needle roller / cylindrical roller thrust bearing, NKXR .. Z series (→ **fig. 33, page 689**)

Greases for capped bearings

Needle roller bearings with one or two seals are supplied greased. The thrust part of combined needle roller bearings with the designation suffix Z is also supplied greased. They are filled with high-quality grease under clean conditions.

The relatively large quantity of grease in the bearings means they can be operated for long periods before relubrication is required. SKF recommends SKF LGWA 2 grease, if relubrication is required.

The technical specifications for the initial grease fill and the grease for relubrication are listed in **table 4**.

Table 4

Technical specifications of greases for capped needle roller bearings

Grease	Temperature range ¹⁾							Thickener	Base oil type	NLGI consistency class	Base oil viscosity [mm ² /s]	
	-50	0	50	100	150	200	250				at 40°C (105 °F)	at 100°C (210 °F)
Initial grease fill								Lithium complex soap	Mineral	2	160	15,5
LGWA 2								Lithium complex soap	Mineral	2	185	15

¹⁾ Refer to the SKF traffic light concept → **page 244**

Relubrication facilities

Depending on the design and size, SKF supplies needle roller bearings with different features to facilitate efficient lubrication and relubrication.

Drawn cup needle roller bearings

SKF supplies all double row drawn cup bearings with one lubrication hole in the outer ring (→ **fig. 8, page 678**), as standard.

On request, SKF can supply any single row drawn cup needle roller bearing for inside diameters under the rollers $F_w \geq 7$ mm with a lubrication hole in the outer ring (→ **fig. 42**).

Needle roller bearings with machined rings

All needle roller bearings with machined rings and flanges, with an outside diameter $D \geq 19$ mm ($F, F_w \geq 12$ mm) have an annular groove and, depending on the bearing size, one or more lubrication holes in the outer ring (→ **fig. 14, page 681**). Sealed needle roller bearings have an additional lubrication hole in the inner ring (→ **fig. 41, page 697**).

Double row machined needle roller bearings without flanges have an annular groove with one lubrication hole in the outer ring (→ **fig. 16, page 682**). For single row bearings without flanges and with an inner ring, SKF supplies certain sizes with one lubrication hole in the inner ring. They are not identified by any designation suffix but are marked in the product tables by a footnote.

Combined needle roller bearings

The needle roller bearing of all combined bearings has an annular groove with one lubrication hole in the outer ring.

Needle roller / full complement thrust ball bearings in the NX series without the designation suffix Z have a cover with lubrication holes over the thrust part of the bearing (→ **fig. 24, page 686**). Most often they are oil lubricated and, therefore, SKF supplies these bearings without grease.

Fig. 42

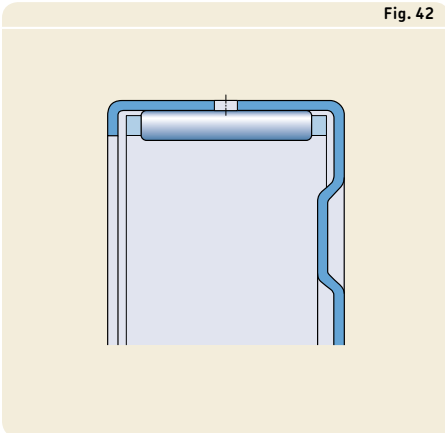

Bearing data

	Needle roller and cage assemblies
Dimension standards	ISO 3030 when $F_w \leq 100$ mm, as far as standardized
Tolerances	<ul style="list-style-type: none"> • rollers: ISO 3096 Grade 2 (grade G2) <ul style="list-style-type: none"> – tolerance of each gauge 2 μm – standard and special gauges (→ table 5, page 707) – specific gauge to be stated when ordering • U: ISO 3030 as far as standardized (–0,2/–0,8 mm)
For additional information (→ page 132)	
Operating clearance	Range of C2 to Normal if: <ul style="list-style-type: none"> • fitted with standard gauge rollers (→ table 5, page 707) • recommended raceway tolerances (→ table 10, page 709) applied • normal operating conditions
Internal clearance	Specific ranges: (→ table 12, page 709)
Misalignment	≈ 1 minute of arc The permissible angular misalignment between the shaft and the housing depends on the size and internal design of the bearing, the radial internal clearance in operation and the forces and moments acting ...
Friction, starting torque, power loss	Frictional moment, starting torque, and power loss can be calculated as specified under <i>Friction</i> (→ page 97), or using the tools available online at skf.com/bearingcalculator .
Defect frequencies	Defect frequencies can be calculated using the tools available online at skf.com/bearingcalculator .

Drawn cup needle roller bearings

Boundary dimensions: ISO 3245, as far as standardized

ISO 3245 as far as standardized

- F_w : \approx within F8 (\rightarrow **table 6, page 707**)

Measuring of F_w :

- bearing must be pressed into a thick-walled ring gauge, bore diameter listed in **table 6 (\rightarrow page 707)**
- check deviation of F_w with measuring mandrel

- C: 0/-0,3 mm

Dimensional accuracy can be checked only if bearings are mounted.

Range of C2 to C3 if recommended tolerances (\rightarrow **table 15, page 716**) applied

–

\approx 1 minute of arc

... on the bearing. As a result, only approximate values are listed here. Any misalignment increases bearing noise and reduces bearing service life.

Bearing data, continued

	Needle roller bearings with machined rings
Dimension standards	Boundary dimensions: ISO 1206 for bearings in the (R)NA 48, (R)NA 49 and (R)NA 69 series
Tolerances	Normal P5 or P6 on request <ul style="list-style-type: none"> • F_w: F6 (→ table 7, page 708) Values are valid for unmounted bearings and when rollers in contact with the outer ring raceway. <p>Tighter tolerance for inside diameter under the rollers on request (designation suffix H followed by two numbers that identify the tolerance limit like H+24+20)</p>
For additional information (→ page 132)	ISO 492 (→ tables 3 to 5, pages 137 to 139)
Operating clearance	Bearings without an inner ring Suitable ranges (→ table 11, page 709) if: <ul style="list-style-type: none"> • recommended shaft tolerance classes applied • housing bore tolerance not tighter than K7 (E)
Internal clearance	Normal (bearings with an inner ring) Check availability of C2, C3 or C4 clearance classes Values: ISO 5753-1 (→ table 13, page 710) Values are valid for unmounted bearings under zero measuring load.
Misalignment	≈ 1 minute of arc The permissible angular misalignment between the shaft and the housing depends on the size and internal design of the bearing, the radial internal clearance in operation and the forces and moments acting ...
Friction, starting torque, power loss	Frictional moment, starting torque, and power loss can be calculated as specified under <i>Friction</i> (→ page 97), or using the tools available online at skf.com/bearingcalculator .
Defect frequencies	Defect frequencies can be calculated using the tools available online at skf.com/bearingcalculator .

Alignment needle roller bearings

d, D: ISO 15

$D \leq 47 \text{ mm}$ → diameter series 0

$D \geq 55 \text{ mm}$ → diameter series 9

- Normal for the inner ring and the outer ring with sphered outside surface
- C of the external drawn sheet steel sleeve: $\pm 0,5 \text{ mm}$
- F_w : F6 (→ **table 7, page 708**)
Values are valid for unmounted bearings and when rollers in contact with the outer ring raceway.

Bearings without an inner ring

Range of C2 to C3 if recommended tolerances (→ **table 15, page 716**) applied

$\leq 3^\circ$ static misalignment

No dynamic misalignment

... on the bearing. As a result, only approximate values are listed here. Any misalignment increases bearing noise and reduces bearing service life.

Bearing data, continued

	Combined needle roller bearings Thrust part Angular contact ball bearing
Dimension standards	Boundary dimensions: ISO 15 – dimension series 59, except for following inner ring parameters in the NKIB 59 series: <ul style="list-style-type: none"> • extended width on one side • slightly larger bore diameter of the narrow part
Tolerances	Normal, except for width of the complete inner ring in the NKIB 59 series: 0/-0,3 mm
For additional information (→ page 132)	Values: Radial bearings → ISO 492 (→ table 3, page 137) Thrust bearings → ISO 199 (→ table 10, page 144)
Operating clearance	–
Internal clearance	Normal (bearings with an inner ring) Check availability of C2, C3 or C4 clearance classes Values: ISO 5753-1 (→ table 13, page 710) Values are valid for unmounted bearings under zero measuring load.
Misalignment	Contact the SKF application engineering service. The permissible angular misalignment between the shaft and the housing depends on the size and internal design of the bearing, the radial internal clearance in operation and the forces and moments acting on the bearing. Any misalignment increases bearing noise and reduces bearing service life.
Friction, starting torque, power loss	Frictional moment, starting torque, and power loss can be calculated as specified under <i>Friction</i> (→ page 97), or using the tools available online at skf.com/bearingcalculator .
Defect frequencies	Defect frequencies can be calculated using the tools available online at skf.com/bearingcalculator .

Thrust ball bearing	Cylindrical roller thrust bearing
Boundary dimensions: DIN 5429-1, except for the bearings in the NX and NX .. Z series that are not standardized.	Boundary dimensions: DIN 5429-1
<ul style="list-style-type: none"> • D: Normal • F_w: F6 (→ table 7, page 708) • d: E8 (→ table 7, page 708) • C: 0/-0,25 mm • C₁ (applicable to NKX and NKXR series only): 0/-0,2 mm 	
<p>Bearings without an inner ring Range slightly less than Normal if recommended tolerances (→ table 17, page 717) applied</p>	
<p>Cannot tolerate any angular misalignment between shaft and housing or between shaft and axial support surfaces in the housing.</p>	

Bearing data, continued

	Needle roller bearing components	
	Needle roller bearing inner rings	Needle rollers
Dimension standards	–	ISO 3096, except for RN-2x6.3 BF/G2 that is not standardized
Tolerances For additional information (→ page 132)	<p>IR series Normal Values: ISO 492 (→ table 3, page 137)</p> <p>LR series</p> <ul style="list-style-type: none"> • F: h6 • B: h12 • d: K6 <p>Values: (→ table 8, page 708)</p>	ISO 3096 Grade 2 for flat end needle rollers Available tolerances (→ table 9, page 708)
Operating clearance	Depends on the bearing type with which the inner ring is combined with.	–
Internal clearance	Depends on the bearing type with which the inner ring is combined with.	–

Table 5

Needle roller gauges	
Gauge type	Gauge
–	µm
Standard gauges	0/-2 -1/-3 -2/-4 -3/-5 -4/-6 -5/-7
Special gauges (to order)	-6/-8 -7/-9 -8/-10 -9/-11

6

Table 6

Tolerances for drawn cup needle roller bearings				
Bearing Inside diameter F _w	Outside diameter D	Ring gauge Bore diameter (measured)	Deviations from nominal inside diameter	
			high	low
mm		mm	µm	
3	6,5	6,484	+24	+6
4	8	7,984	+28	+10
5	9	8,984	+28	+10
6	10	9,984	+28	+10
7	11	10,980	+31	+13
8	12	11,980	+31	+13
9	13	12,980	+31	+13
10	14	13,980	+31	+13
12	16	15,980	+34	+16
12	18	17,980	+34	+16
13	19	18,976	+34	+16
14	20	19,976	+34	+16
15	21	20,976	+34	+16
16	22	21,976	+34	+16
17	23	22,976	+34	+16
18	24	23,976	+34	+16
20	26	25,976	+41	+20
22	28	27,976	+41	+20
25	32	31,972	+41	+20
28	35	34,972	+41	+20
30	37	36,972	+41	+20
32	39	38,972	+50	+25
35	42	41,972	+50	+25
40	47	46,972	+50	+25
45	52	51,967	+50	+25
50	58	57,967	+50	+25
55	63	62,967	+60	+30
60	68	67,967	+60	+30

6 Needle roller bearings

Table 7

ISO tolerance classes

Nominal diameter		E8(E) Deviation		F6(E) Deviation	
over	incl.	high	low	high	low
mm		µm		µm	
-	3	-	-	+12	+6
3	6	-	-	+18	+10
6	10	+47	+25	+22	+13
10	18	+59	+32	+27	+16
18	30	+73	+40	+33	+20
30	50	+89	+50	+41	+25
50	80	+106	+60	+49	+30
80	120	-	-	+58	+36
120	180	-	-	+68	+43
180	250	-	-	+79	+50
250	315	-	-	+88	+56
315	400	-	-	+98	+62
400	500	-	-	+108	+68

Table 8

ISO tolerance classes for LR series inner rings

Nominal dimension		h6(E) Deviations		h12(E) Deviations		K6(E) Deviations	
over	incl.	high	low	high	low	high	low
mm		µm		µm		µm	
6	10	0	-9	-	-	+2	-7
10	18	0	-11	0	-180	+2	-9
18	30	0	-13	0	-210	+2	-11
30	50	0	-16	0	-250	+3	-13
50	80	0	-19	-	-	-	-

Table 9

Dimensional and geometrical accuracy of SKF needle rollers, grade G2

Diameter D _w Deviation		Gauge tolerance	Gauge limits	Roundness (max. circularity deviation in accordance with ISO 3096)	Length L _w Tolerance class
high	low				
µm					-
0	-10	2	0/-2 -1/-3 -2/-4 -3/-5 -4/-6 -5/-7 -6/-8 -7/-9 -8/-10	1	h13(E)

Preferred diameter deviations range from 0 to -7 µm.

Each gauge is packed separately and marked with the gauge limits, e.g. N/M2 or M2/M4, where M signifies minus and N zero. For a needle roller with a 2 mm nominal diameter and gauge limits M2/M4, the actual diameter is between 1,998 mm and 1,996 mm.

Table 10

Raceway tolerance classes for needle roller and cage assemblies

Shaft		Housing/shaft tolerance classes ¹⁾ for operating clearance		
Nominal diameter over	incl.	lower side	medium	higher side
mm		-		
-	80	G6/j5 H6/h5	G6/h5 H6/g5	G6/g6 H6/f6
80	120	G6/h5	G6/g5	G6/f6
120	-	G6/h5 -	G6/g5 H6/f5	G6/f6 H6/e6

¹⁾ All ISO tolerance classes are valid with the envelope requirement (such as H7(Ⓔ)) in accordance with ISO 14405-1.

Table 11

Shaft tolerance classes for machined needle roller bearings without an inner ring

Nominal inside diameter		Shaft tolerance classes ¹⁾ for shaft raceways to give operating clearance		
F _w over	incl.	lower side	medium	higher side
mm		-		
-	65	k5	h5	g6
65	80	k5	h5	f6
80	160	k5	g5	f6
160	180	k5	g5	e6
180	200	j5	g5	e6
200	250	j5	f6	e6
250	315	h5	f6	e6
315	400	g5	f6	d6

¹⁾ All ISO tolerance classes are valid with the envelope requirement (such as h7(Ⓔ)) in accordance with ISO 14405-1.

Table 12

Mounting scheme – example

Needle roller and cage assembly: K 16x22x12
 Housing bore diameter: 22H6(Ⓔ) [mm], deviation 0/+13 μm
 Shaft diameter: 16h5(Ⓔ) [mm], deviation 0/-8 μm

Shaft diameter Deviation group	Housing bore diameter Deviation groups							
	0 to +3 Needle roller gauge limits	Radial internal clearance	+3 to +6 Needle roller gauge limits	Radial internal clearance	+6 to +9 Needle roller gauge limits	Radial internal clearance	+9 to +13 Needle roller gauge limits	Radial internal clearance
μm	μm							
0 to -3					-5/-7	18-24	-3/-5	17-24
-3 to -6			-5/-7	18-24	-3/-5 -4/-6	17-25	-2/-4	18-25
-6 to -8	-5/-7 -6/-8	18-25	-3/-5 -4/-6	17-24	-2/-4 -3/-5	18-25	0/-2 -1/-3	17-25

The mean value of the needle roller gauge should be used to calculate the internal clearance, e.g. -6 μm for the gauge -5 to -7 μm.

6 Needle roller bearings

Table 13

Radial internal clearance for needle roller bearings

Bore diameter d		Radial internal clearance							
over	incl.	C2		Normal		C3		C4	
		min.	max.	min.	max.	min.	max.	min.	max.
mm		µm							
-	30	0	25	20	45	35	60	50	75
30	40	5	30	25	50	45	70	60	85
40	50	5	35	30	60	50	80	70	100
50	65	10	40	40	70	60	90	80	110
65	80	10	45	40	75	65	100	90	125
80	100	15	50	50	85	75	110	105	140
100	120	15	55	50	90	85	125	125	165
120	140	15	60	60	105	100	145	145	190
140	160	20	70	70	120	115	165	165	215
160	180	25	75	75	125	120	170	170	220
180	200	35	90	90	145	140	195	195	250
200	225	45	105	105	165	160	220	220	280
225	250	45	110	110	175	170	235	235	300
250	280	55	125	125	195	190	260	260	330
280	315	55	130	130	205	200	275	275	350
315	355	65	145	145	225	225	305	305	385
355	400	100	190	190	280	280	370	370	460

	Needle rollers and cage assemblies	Drawn cup needle roller bearings ¹⁾	Needle roller bearings with machined rings	Alignment needle roller bearings
Minimum load For additional information (→ page 86)	$F_{rm} = 0,02 C$ The weight of the components supported by the bearing, together with external forces, generally exceed the requisite minimum load. If this is not the case, the bearing must be subjected to an additional radial load.			
Equivalent dynamic bearing load For additional information (→ page 85)	$P = F_r$			
Equivalent static bearing load For additional information (→ page 88)	$P_0 = F_r$			
Symbols	C = basic dynamic load rating [kN] (→ product tables) F_r = radial load [kN] F_{rm} = minimum radial load [kN] P = equivalent dynamic bearing load [kN] P_0 = equivalent static bearing load [kN] s_0 = static safety factor			

¹⁾ SKF recommends applying a static safety factor $s_0 \geq 3$, i.e. $s_0 = C_0/P_0 \geq 3$.

Loads, continued

	Combined needle roller bearings	
	Thrust part ¹⁾ Angular contact ball bearing	Thrust ball bearing
Minimum load	$F_{am} = 0,25 \frac{C_0}{1\,000} \left(\frac{n d_m}{100\,000} \right)^2$	$F_{am} = A \left(\frac{n}{1\,000} \right)^2$
For additional information (→ page 86)	The weight of the components supported by the bearing, together with external forces, generally exceed the requisite minimum load. If this is ...	
Equivalent dynamic bearing load	$P = F_a$ F_a must not exceed $0,25 F_r$.	$P = F_a$
For additional information (→ page 85)		
Equivalent static bearing load	$P_0 = F_a$ F_a must not exceed $0,25 F_r$.	$P_0 = F_a$
For additional information (→ page 88)		

¹⁾ It is necessary to calculate the life of the radial needle roller bearing and the thrust bearing separately. For the radial part, see *Needle roller bearings with machined rings* (→ page 711).

Cylindrical roller thrust bearing	Symbols
$F_{am} = 0,0005 C_0 + A \left(\frac{n}{1\,000} \right)^2$	<p>A = minimum load factor (→ product tables)</p> <p>C₀ = basic static load rating [kN] (→ product tables)</p> <p>d_m = bearing mean diameter [mm] = 0,5 (d + D)</p> <p>F_a = axial load [kN]</p> <p>F_{am} = minimum axial load [kN]</p> <p>n = rotational speed [r/min]</p> <p>P = equivalent dynamic bearing load [kN]</p> <p>P₀ = equivalent static bearing load [kN]</p>
... not the case, the bearing must be subjected to an additional axial load.	
$P = F_a$	
$P_0 = F_a$	

Temperature limits

The permissible operating temperature for needle roller bearings can be limited by:

- the dimensional stability of the bearing rings and rollers
- the cages
- the seals
- the seating rings
- the lubricant

When temperatures outside the permissible range are expected, contact the SKF application engineering service.

Bearing rings and rollers

SKF needle roller bearings undergo a special heat treatment. The bearings are heat stabilized up to at least 120 °C (250 °F).

Drawn cup needle roller bearings are heat stabilized up to at least 140 °C (285 °F).

Cages

Steel cages can be used at the same operating temperatures as the bearing rings and rollers. For temperature limits of polymer cages, refer to *Cage materials* (→ page 152).

Seals

The permissible operating temperature for seals depends on the material:

- NBR seals:
–40 to +100 °C (–40 to +210 °F)
Temperatures up to 120 °C (250 °F) can be tolerated for brief periods.
- PUR seals:
–30 to +100 °C (–20 to +210 °F)
- FKM seals:
–30 to +200 °C (–20 to +390 °F)

Seating rings

The permissible operating temperature for seating rings fitted to alignment needle roller bearings is –30 to +100 °C (–20 to +210 °F).

Lubricants

Temperature limits for the grease used in capped needle roller bearings are provided in **table 4** (→ page 698) and for full complement drawn cup needle roller bearings in **table 1** (→ page 679). Temperature limits for other

SKF greases are provided under *Lubrication* (→ page 239).

When using lubricants not supplied by SKF, the temperature limits should be evaluated according to the SKF traffic light concept (→ page 244).

Permissible speed

The permissible speed can be estimated using the speed ratings listed in the product tables and applying the information provided under *Speeds* (→ page 117). If no reference speed is listed in the product tables, the limiting speed is the permissible speed.

Design of bearing arrangements

Abutment dimensions

Needle roller and cage assemblies

Needle roller and cage assemblies should be guided axially by the fine turned and polished surfaces of adjacent machine components. For high-speed operations they should be hardened and ground. Appropriate abutment diameters are provided in **table 14**.

Interruptions in the surface of adjacent machine components should be avoided. Snap rings can be used in less demanding applications, otherwise an intermediate ring, e.g. a spring steel washer, should be mounted between the snap ring and the cage assembly.

Needle roller bearings with machined rings, without flanges

The cage of needle roller bearings without flanges should be guided axially by the fine turned and polished surfaces of adjacent machine components. Appropriate abutment diameters are listed in the product tables.

Table 14

Abutment dimensions for needle roller and cage assemblies

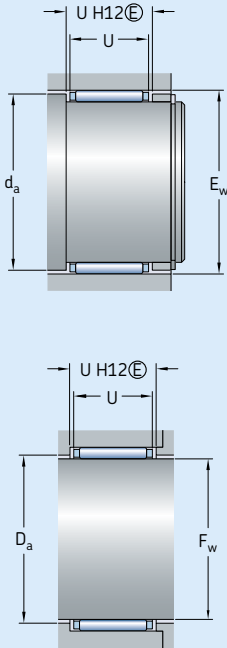

Needle roller and cage assembly		Shaft abutment	Housing abutment
Inside diameter		d_a	D_a
F_w over	incl.		
mm		mm	mm
-	25	$E_w - 0,3$	$F_w + 0,4$
25	65	$E_w - 0,5$	$F_w + 0,5$
65	-	$E_w - 1$	$F_w + 1$

Combined needle roller bearings

The diameter of the thrust bearing support surface in the housing should be at least 0,5 mm larger than the dimension D_1 or D_2 (→ **fig. 43**). The values for the diameters D_1 and D_2 for needle roller / thrust ball bearings and needle roller / cylindrical roller thrust bearings are listed in the product tables.

Fig. 43

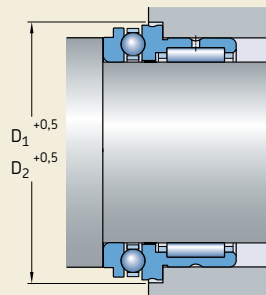

6 Needle roller bearings

Shaft and housing tolerances

The following tables provide tolerance classes to obtain suitable fits and an appropriate operating clearance (→ *Operating clearance*, page 700) for the following needle roller bearing types:

- drawn cup needle roller bearings
- needle roller bearings with machined inner and outer rings
- alignment needle roller bearings
- combined needle roller bearings

The tolerances of raceways on shafts and in housings for needle roller and cage assemblies and of raceways on shafts for machined needle roller bearings without an inner ring, significantly influence the operating clearance of the bearing and, therefore, are provided under *Operating clearance* (→ page 700).

For additional information about raceways, refer to *Raceways on shafts and in housings* (→ page 210).

Table 15

Shaft and housing tolerance classes for drawn cup and alignment needle roller bearings

Housing material ²⁾	Tolerance classes ¹⁾		Shaft inner ring seat
	Housing bore seat ³⁾	Raceway on the shaft	
Steel, cast iron	N6	h5	k5
	N7	h6	j6
Light alloy	R6	h5	k5
	R7	h6	j6

¹⁾ All ISO tolerance classes are valid with the envelope requirement (such as H7(Ⓔ)) in accordance with ISO 14405-1.

²⁾ For drawn cup needle roller bearings that are mounted in housings that are not rigid, the shaft tolerance giving the desired radial clearance must be determined by trial and error.

³⁾ The geometrical accuracy in accordance with ISO 1101 for the housing bore of drawn cup needle roller bearings must correspond to IT5/2 tolerance grade.

Drawn cup needle roller bearings

Table 15 provides suitable tolerance classes for the housing bore and shaft for drawn cup needle roller bearings with or without an inner ring.

Needle roller bearings with machined rings

Table 16 provides suitable tolerance classes for the shaft for needle roller bearings with machined inner and outer rings.

The recommended housing fits for needle roller bearings with machined inner and outer rings are provided in **tables 4** and **5** (→ **pages 174** and **175**).

Alignment needle roller bearings

Table 15 provides suitable tolerance classes for the housing bore and shaft for alignment needle roller bearings with or without an inner ring.

Table 16

Shaft tolerance classes for needle roller bearings with machined inner and outer rings on solid steel shafts

Conditions	Shaft diameter	Tolerance classes ¹⁾
–	mm	–
Rotating inner ring load or direction of load indeterminate		
Light and variable loads ($P \leq 0,05 C$)	≤ 10	k5
	> 10 to 25	k6
	> 25 to 100	m6
Normal to heavy loads ($0,05 C < P \leq 0,1 C$)	≤ 25	k5
	> 25 to 60	m6
	> 60 to 100	n6
	> 100 to 400	p6 ²⁾
Heavy to very heavy loads ($P > 0,1 C$)	> 50 to 100	n6 ²⁾
	> 100 to 200	p6 ²⁾
	> 200	r6 ²⁾
Stationary inner ring load		
Easy axial displacement of the inner ring on the shaft desirable		g6
Easy axial displacement of the inner ring on the shaft unnecessary		h6

¹⁾ All ISO tolerance classes are valid with the envelope requirement (such as h7(Ⓔ)) in accordance with ISO 14405-1.

²⁾ Bearings with radial internal clearance greater than Normal may be necessary.

Combined needle roller bearings

Table 17 provides suitable tolerance classes for the housing bore and shaft for combined needle roller bearings with or without an inner ring.

Table 17

Shaft and housing tolerance classes for combined needle roller bearings

Thrust part	Tolerance classes ¹⁾	
	Housing bore seat	Shaft seat (raceway and inner ring seat)
Angular contact ball bearing	M6	k5
Thrust ball bearing	K6 ²⁾	k5
Cylindrical roller thrust bearing	K6 ²⁾	k5

¹⁾ All ISO tolerance classes are valid with the envelope requirement (such as H7(E)) in accordance with ISO 14405-1.

²⁾ For stiff bearing arrangements, SKF recommends an M6(E) housing bore tolerance class.

6 Needle roller bearings

Mounting

Drawn cup and alignment needle roller bearings should be pressed into the housing bore using a mounting dolly (→ **fig. 44**). An O-ring provides a simple means of retaining the bearing on the mounting dolly. The stamped (side face with the designation) should abut the flange of the mounting dolly.

Special care should be taken to prevent the sleeve from skewing or tilting when it is being pressed into the housing. Otherwise the rollers and raceways could easily be damaged.

For grease lubricated bearings, the bearing should be lubricated prior to mounting.

Paired mounting

If roller sets or bearings are to be mounted immediately adjacent to each other, the load should be shared equally by both roller sets or bearings. Therefore, the following need to be considered:

- Full complement needle roller arrangements should incorporate rollers of the same gauge.
- Needle roller and cage assemblies should incorporate rollers of the same gauge.
- Drawn cup needle roller bearings should have the same deviations from the nominal inside diameter F_w .

A delivery of needle rollers of the same nominal diameter may contain packages of one or more gauges. The gauge limits are also printed on the package.

For needle roller and cage assemblies the deviation from the nominal dimensions of the fitted needle rollers is printed on the package.

For additional information about gauges and inside diameter, refer to *Tolerances* (→ **page 700**).

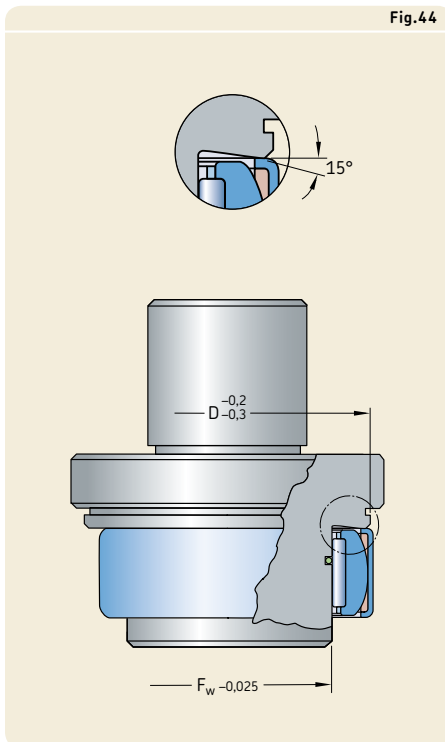

Designation system

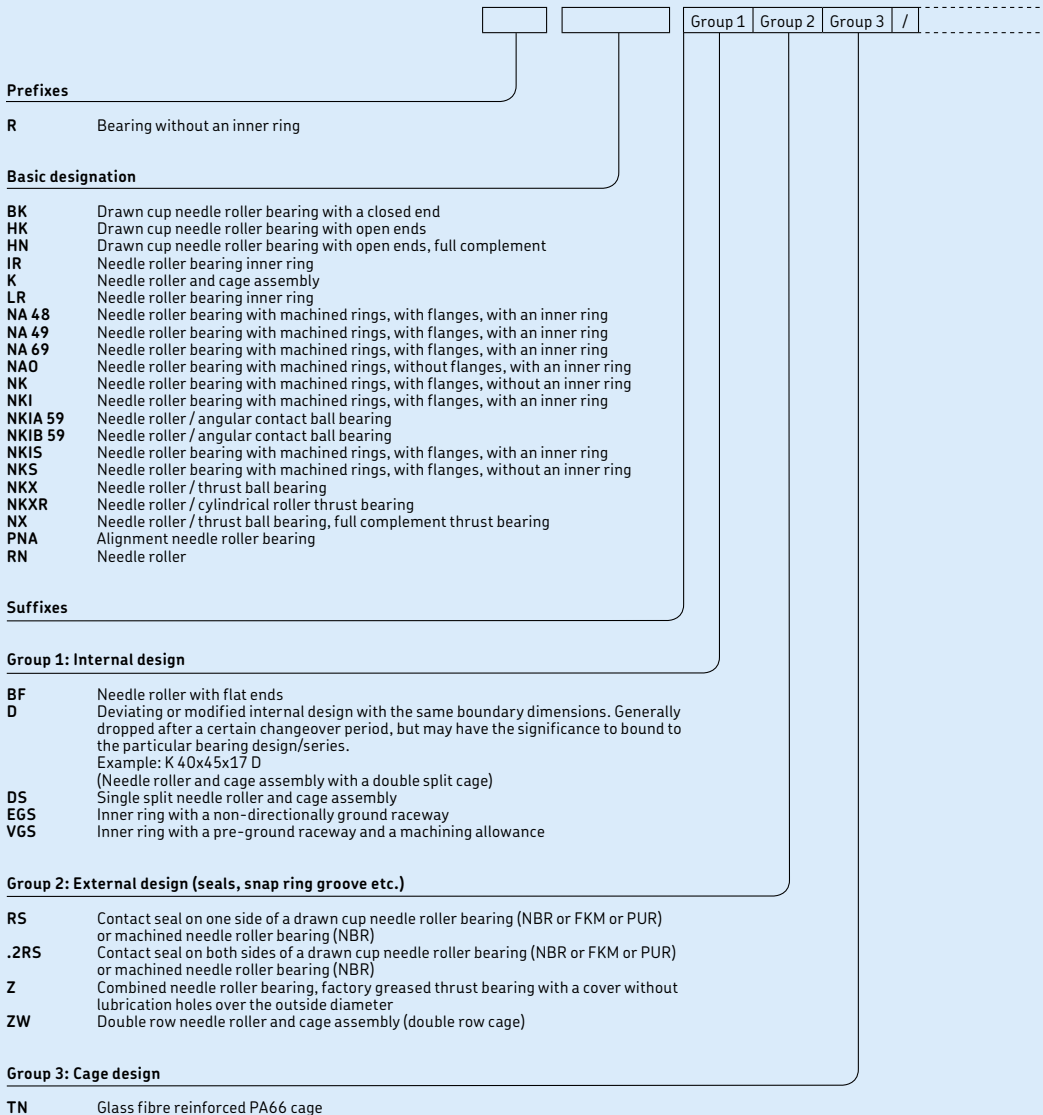

Group 4					
4.1	4.2	4.3	4.4	4.5	4.6

Group 4.6: Other variants

VG052 Single split PES (polyethersulfone) cage

Group 4.5: Lubrication

- AS..** Outer ring with lubrication hole(s), the number following indicates the number of holes
- ASR..** Outer ring with annular groove and lubrication hole(s), the number following indicates the number of holes
- IS..** Inner ring with lubrication hole(s), the number following indicates the number of holes
- ISR..** Inner ring with annular groove and lubrication hole(s), the number following indicates the number of holes
- SM..** Special grease, two numbers following identify the grease

Group 4.4: Stabilization

- S0** Bearing heat stabilized for operating temperatures ≤ 150 °C (300 °F)
- S1** Bearing heat stabilized for operating temperatures ≤ 200 °C (390 °F)
- S2** Bearing heat stabilized for operating temperatures ≤ 250 °C (480 °F)
- S3** Bearing heat stabilized for operating temperatures ≤ 300 °C (570 °F)

Group 4.3: Bearing sets, matched bearings

..S Matched bearings for an equal load distribution. The number preceding indicates the number of bearings, e.g. NK 50/25 TN/25

Group 4.2: Accuracy, clearance, preload, quiet running

- /SORT..** Tolerance grade of needle rollers of a needle roller and cage assembly, the numbers following identify the actual limits in µm, e.g. /SORT-2-4
- CN** Normal radial internal clearance; only used together with an additional letter that identifies a reduced or displaced clearance range
 - H** Reduced clearance range corresponding to the upper half of the actual clearance range
 - L** Reduced clearance range corresponding to the lower half of the actual clearance range
 - M** Reduced clearance range corresponding to the two middle quarters of the actual clearance range
 - P** Displaced clearance range comprising the upper half of the actual clearance range plus the lower half of the next larger clearance range
 - R** Normal clearance range in accordance with the withdrawn DIN 620-4:1982
 The above letters H, L, M and P are also used together with the clearance classes C2, C3, C4
- C2** Radial internal clearance smaller than Normal
- C3** Radial internal clearance greater than Normal
- C4** Radial internal clearance greater than C3
- G2** Needle roller in accordance with ISO 3096 Grade 2
- H..** Bearing without an inner ring and reduced inside diameter (under rollers) tolerance, the numbers following indicate the tolerance limits in µm, e.g. H+27+20
- M../M..** Diameter tolerance of needle rollers, e.g. M2/M4 indicates diameter tolerance -2 to -4 µm
- N/M..** Diameter tolerance of needle rollers, e.g. N/M2 indicates diameter tolerance 0 to -2 µm
- P5** Dimensional and running accuracy to P5 tolerance class
- P6** Dimensional and running accuracy to P6 tolerance class
- P62** P6 + C2
- P63** P6 + C3
- P6CNR** P6 + CNR

Group 4.1: Materials, heat treatment

6.1 Needle roller and cage assemblies

F_w 3 – 22 mm

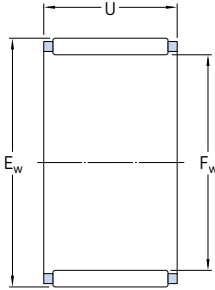

Principal dimensions			Basic load ratings		Fatigue load limit	Speed ratings		Mass	Designation	Appropriate seal ¹⁾
F _w	E _w	U	dynamic C	static C ₀	P _u	Reference speed	Limiting speed			Designation
mm			kN		kN	r/min		g	–	–
3	5	7	1,51	1,34	0,134	40 000	45 000	0,3	K 3x5x7 TN	–
	5	9	1,68	1,53	0,153	40 000	45 000	0,4	K 3x5x9 TN	–
	6	7	1,42	1,02	0,104	38 000	43 000	0,4	K 3x6x7 TN	–
4	7	7	1,72	1,32	0,137	36 000	43 000	0,5	K 4x7x7 TN	–
	7	10	2,29	1,9	0,204	36 000	43 000	0,7	K 4x7x10 TN	–
5	8	8	2,29	2	0,212	36 000	40 000	0,7	K 5x8x8 TN	–
	8	10	2,92	2,7	0,29	36 000	40 000	0,9	K 5x8x10 TN	–
6	9	8	2,55	2,36	0,25	34 000	38 000	0,8	K 6x9x8 TN	–
	9	10	3,3	3,2	0,345	34 000	38 000	1,1	K 6x9x10 TN	–
	10	13	3,69	3,15	0,36	34 000	38 000	1,9	K 6x10x13 TN	G 6x10x2 S
7	9	7	1,68	1,83	0,19	34 000	38 000	0,6	K 7x9x7 TN	–
	10	8	2,81	2,75	0,29	32 000	36 000	0,9	K 7x10x8 TN	–
	10	10	3,58	3,75	0,415	32 000	36 000	1	K 7x10x10 TN	–
8	11	8	3,03	3,1	0,335	32 000	36 000	1	K 8x11x8 TN	–
	11	10	3,8	4,25	0,465	32 000	36 000	1,2	K 8x11x10 TN	–
	11	13	5,01	5,85	0,67	32 000	36 000	1,7	K 8x11x13 TN	–
	12	10	4,84	4,75	0,54	30 000	34 000	2	K 8x12x10 TN	G 8x12x3
9	12	10	4,4	5,2	0,57	30 000	34 000	1,5	K 9x12x10 TN	–
	12	13	5,72	7,2	0,815	30 000	34 000	2,1	K 9x12x13 TN	–
10	13	10	4,57	5,7	0,63	28 000	32 000	1,6	K 10x13x10 TN	–
	13	13	5,94	8	0,9	28 000	32 000	2,3	K 10x13x13 TN	–
	13	16	6,82	9,5	1,08	28 000	32 000	2,9	K 10x13x16 TN	–
	14	10	5,61	6,1	0,695	28 000	32 000	2,5	K 10x14x10 TN	G 10x14x3
	14	13	7,21	8,5	0,98	28 000	32 000	4,6	K 10x14x13 TN	G 10x14x3
	16	12	7,65	7,2	0,85	28 000	32 000	5,5	K 10x16x12 TN	–
12	15	10	4,73	6,2	0,695	26 000	30 000	2,9	K 12x15x10 TN	–
	15	13	6,16	8,65	0,98	26 000	30 000	2,3	K 12x15x13 TN	–
	16	13	7,65	9,5	1,1	26 000	30 000	3,6	K 12x16x13 TN	G 12x16x3
	17	13	9,13	10,4	1,22	26 000	30 000	4,9	K 12x17x13 TN	–
	17	13	9,13	10,4	1,22	26 000	30 000	4,9	K 12x17x13 TN	–
	18	12	9,52	10	1,18	26 000	30 000	6	K 12x18x12 TN	G/S0 12x18x3

¹⁾ For additional information, visit skf.com/seals.

Principal dimensions			Basic load ratings		Fatigue load limit	Speed ratings		Mass	Designation	Appropriate seal ¹⁾	
F _w	E _w	U	dynamic C	static C ₀	P _u	Reference speed	Limiting speed			Designation	
mm			kN		kN	r/min		g	-	-	
14	18	10	6,93	8,65	1	24 000	28 000	4	K14x18x10	-	
	18	13	7,92	10,2	1,18	24 000	28 000	6,5	K14x18x13	-	
	18	15	9,13	12,5	1,46	24 000	28 000	5	K14x18x15 TN	-	
	18	17	10,5	14,6	1,7	24 000	28 000	8	K14x18x17	-	
	20	12	9,9	10,6	1,25	24 000	28 000	8,5	K14x20x12	G/SD 14x20x3	
15	18	17	7,65	12,2	1,4	24 000	28 000	4,6	K15x18x17 TN	-	
	19	10	7,21	9,3	1,08	24 000	28 000	5	K15x19x10	-	
	19	13	8,25	11,2	1,29	24 000	28 000	7	K15x19x13	-	
	19	17	10,8	15,6	1,86	24 000	28 000	9,5	K15x19x17	-	
	20	13	9,52	11,6	1,34	24 000	26 000	7	K15x20x13	-	
	21	15	13,8	16,3	2	24 000	26 000	11	K15x21x15	G/SD 15x21x3	
	21	21	18,7	24,5	3	24 000	26 000	17	K15x21x21	G/SD 15x21x3	
16	20	10	7,48	10	1,16	24 000	26 000	5,5	K16x20x10	-	
	20	13	8,58	12	1,37	24 000	26 000	7,5	K16x20x13	-	
	20	17	11,2	17	2	24 000	26 000	10	K16x20x17	-	
	22	12	11	12,5	1,5	22 000	26 000	10	K16x22x12	G/SD 16x22x3	
	22	16	14,2	17,6	2,12	22 000	26 000	12	K16x22x16	G/SD 16x22x3	
	22	20	17,6	22,8	2,8	22 000	26 000	17	K16x22x20	G/SD 16x22x3	
	24	20	20,5	23,6	2,9	22 000	24 000	22	K16x24x20	G/SD 16x24x3	
17	21	10	7,81	10,8	1,22	22 000	26 000	5,5	K17x21x10	-	
	21	13	10,1	14,6	1,73	22 000	26 000	6,5	K17x21x13	-	
	21	17	11,7	18,3	2,12	22 000	26 000	9,5	K17x21x17	-	
18	22	10	8,09	11,4	1,32	22 000	24 000	6	K18x22x10	-	
	22	13	8,8	12,9	1,5	22 000	24 000	8	K18x22x13	-	
	22	17	11,7	18,3	2,16	22 000	24 000	11	K18x22x17	-	
	24	12	12,1	15	1,8	20 000	24 000	12	K18x24x12	G/SD 18x24x3	
	24	13	12,5	15,3	1,86	20 000	24 000	13	K18x24x13	G/SD 18x24x3	
19	24	20	19,4	27	3,25	20 000	24 000	18	K18x24x20	G/SD 18x24x3	
	25	22	22	29	3,55	20 000	24 000	23	K18x25x22	-	
	23	13	9,13	13,7	1,6	20 000	24 000	8	K19x23x13	-	
19	23	17	12,1	19,3	2,28	20 000	24 000	11	K19x23x17	-	
	20	24	10	8,58	12,9	1,46	20 000	22 000	6,5	K20x24x10	-
24		13	9,52	14,6	1,66	20 000	22 000	9	K20x24x13	-	
24		17	12,5	20,8	2,4	20 000	22 000	12	K20x24x17	-	
26		12	12,8	16,3	1,96	19 000	22 000	11	K20x26x12	G/SD 20x26x4	
26		13	13,8	18	2,16	19 000	22 000	12	K20x26x13	G/SD 20x26x4	
26		17	18,3	26	3,2	19 000	22 000	16	K20x26x17	G/SD 20x26x4	
26		20	20,1	29	3,6	19 000	22 000	19	K20x26x20	G/SD 20x26x4	
28		16	19	22,4	2,7	18 000	20 000	20	K20x28x16	G/SD 20x28x4	
28		20	22,9	28,5	3,45	18 000	20 000	27	K20x28x20	G/SD 20x28x4	
28		25	29,2	39	4,9	18 000	20 000	32	K20x28x25	G/SD 20x28x4	
20	30	30	34,1	41,5	5,2	17 000	20 000	49	K20x30x30	-	
	21	25	13	9,68	15,3	1,76	19 000	22 000	9	K21x25x13	-
22		26	10	8,8	13,7	1,56	18 000	20 000	7,5	K22x26x10	-
		26	13	10,1	16,3	1,86	18 000	20 000	9,5	K22x26x13	-
		26	17	13,2	22,8	2,7	18 000	20 000	12	K22x26x17	-
		28	17	18,3	27	3,25	17 000	20 000	18	K22x28x17	G/SD 22x28x4
		29	16	19,4	25,5	3,05	17 000	19 000	16	K22x29x16	-
		30	15	19	23,6	2,8	17 000	19 000	18	K22x30x15 TN	G/SD 22x30x4
32	24	31,9	40	4,9	16 000	18 000	43	K22x32x24	-		

¹⁾ For additional information, visit skf.com/seals.

6.1 Needle roller and cage assemblies

F_w 23 – 45 mm

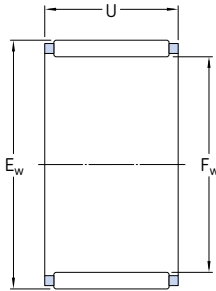

K

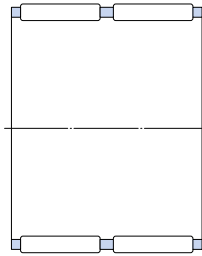

K..ZW

Principal dimensions			Basic load ratings		Fatigue load limit	Speed ratings		Mass	Designation	Appropriate seal ¹⁾ Designation
F _w	E _w	U	dynamic C	static C ₀	P _u	Reference speed	Limiting speed			
mm			kN		kN	r/min		g	–	–
23	35	16	24,2	23,2	2,9	15 000	17 000	29	K 23x35x16 TN	–
24	28	10	9,35	15	1,73	17 000	19 000	8,5	K 24x28x10	–
	28	13	10,6	18	2,08	17 000	19 000	10	K 24x28x13	–
	28	17	14	25,5	3	17 000	19 000	13	K 24x28x17	–
	30	17	18,7	27,5	3,4	16 000	18 000	19	K 24x30x17	–
	30	31	26,4	43	5,3	16 000	18 000	32	K 24x30x31 ZW	–
25	29	10	9,52	15,6	1,8	16 000	18 000	8,5	K 25x29x10	–
	29	13	10,8	18,6	2,16	16 000	18 000	11	K 25x29x13	–
	29	17	14,2	26,5	3,1	16 000	18 000	14	K 25x29x17	–
	30	17	17,9	30,5	3,6	16 000	18 000	16	K 25x30x17	–
	30	20	20,9	36,5	4,4	16 000	18 000	18	K 25x30x20	–
	30	26	20,5	36	4,15	16 000	18 000	19	K 25x30x26 ZW	–
	31	17	18,7	28,5	3,45	16 000	18 000	19	K 25x31x17	–
	31	21	23,3	38	4,75	16 000	18 000	20	K 25x31x21	–
	32	16	19,8	27,5	3,35	15 000	17 000	21	K 25x32x16	G 25x32x4
	33	20	27,5	38	4,65	15 000	17 000	33	K 25x33x20	G/SD 25x33x4
33	24	31,9	47,5	5,85	15 000	17 000	39	K 25x33x24	G/SD 25x33x4	
35	30	44,6	62	7,8	15 000	17 000	65	K 25x35x30	G/SD 25x35x4	
26	30	13	11,2	19,6	2,28	16 000	18 000	11	K 26x30x13	–
	30	17	14,7	27,5	3,25	16 000	18 000	15	K 26x30x17	–
	30	22	15,1	29	3,35	16 000	18 000	12	K 26x30x22 ZW	–
28	33	13	14,7	24,5	2,85	14 000	16 000	13	K 28x33x13	–
	33	17	19	33,5	4,05	14 000	16 000	17	K 28x33x17	–
	34	17	20,9	33,5	4,15	14 000	16 000	24	K 28x34x17	–
	35	16	20,5	30	3,55	14 000	16 000	24	K 28x35x16	G/SD 28x35x4
	35	18	22,9	34,5	4,15	14 000	16 000	27	K 28x35x18	G/SD 28x35x4
	40	25	42,9	55	6,95	13 000	15 000	70	K 28x40x25	–

¹⁾ For additional information, visit skf.com/seals.

Principal dimensions			Basic load ratings		Fatigue load limit	Speed ratings		Mass	Designation	Appropriate seal ¹⁾
F _w	E _w	U	dynamic C	static C ₀	P _u	Reference speed	Limiting speed			Designation
mm			kN		kN	r/min		g	–	–
30	34	13	11,9	22	2,55	14 000	15 000	14	K 30x34x13	–
	35	13	15,1	25,5	3	13 000	15 000	14	K 30x35x13	–
	35	17	18,7	34	4,05	13 000	15 000	19	K 30x35x17	–
	35	27	29,2	60	7,35	13 000	15 000	30	K 30x35x27	–
	37	16	22	33,5	4	13 000	15 000	27	K 30x37x16	G/SD 30x37x4
	37	18	25,1	39	4,65	13 000	15 000	30	K 30x37x18	G/SD 30x37x4
	40	18	30,3	40	4,9	12 000	14 000	48	K 30x40x18	G/SD 30x40x4
	40	30	46,8	69,5	8,65	12 000	14 000	73	K 30x40x30	G/SD 30x40x4
32	37	13	14,7	25,5	3	13 000	14 000	18	K 32x37x13	–
	37	17	19	35,5	4,25	13 000	14 000	19	K 32x37x17	–
	37	27	28,6	60	7,35	13 000	14 000	30	K 32x37x27	–
	38	20	25,1	45	5,6	12 000	14 000	30	K 32x38x20	–
	39	16	22,9	35,5	4,25	12 000	14 000	37	K 32x39x16	–
	39	18	25,5	41,5	5	12 000	14 000	31	K 32x39x18	–
	40	25	35,8	58,5	7,2	12 000	14 000	49	K 32x40x25	–
	40	42	48,4	83	10,2	12 000	14 000	77	K 32x40x42 ZWTN	–
46	32	62,7	83	10,4	11 000	13 000	119	K 32x46x32	–	
35	40	13	15,4	28	3,25	12 000	13 000	19	K 35x40x13	–
	40	17	19,8	39	4,65	12 000	13 000	21	K 35x40x17	–
	40	25	28,1	60	7,35	12 000	13 000	31	K 35x40x25	–
	40	27	23,8	49	6	12 000	13 000	39	K 35x40x27 TN	–
	42	16	23,3	37,5	4,5	11 000	13 000	34	K 35x42x16	G/SD 35x42x4
	42	18	26,4	44	5,3	11 000	13 000	34	K 35x42x18	G/SD 35x42x4
	42	20	29,2	50	6	11 000	13 000	37	K 35x42x20	G/SD 35x42x4
	42	30	37,4	68	8,5	11 000	13 000	67	K 35x42x30	G/SD 35x42x4
45	20	35,2	50	6,2	11 000	12 000	56	K 35x45x20	G/SD 35x45x4	
45	30	50,1	80	10	11 000	12 000	80	K 35x45x30	G/SD 35x45x4	
37	42	17	21,6	43	5,2	11 000	13 000	22	K 37x42x17	–
38	43	17	19,8	39	4,65	11 000	12 000	29	K 38x43x17	–
	43	27	30,3	68	8,3	11 000	12 000	43	K 38x43x27	–
	46	20	34,1	57	6,95	10 000	12 000	47	K 38x46x20	–
	46	32	52,3	100	12,5	10 000	12 000	76	K 38x46x32	–
39	44	26	26	57	6,7	10 000	12 000	45	K 39x44x26 ZW	–
40	45	13	16,8	32,5	3,8	10 000	12 000	18	K 40x45x13	–
	45	17	20,5	41,5	5	10 000	12 000	31	K 40x45x17	–
	45	27	31,4	73,5	9	10 000	12 000	46	K 40x45x27	–
	47	18	28,6	50	6,1	10 000	11 000	39	K 40x47x18	G/SD 40x47x4
	47	20	31,4	57	6,95	10 000	11 000	42	K 40x47x20	G/SD 40x47x4
	48	20	34,7	58,5	7,35	10 000	11 000	49	K 40x48x20	–
42	47	13	17,2	33,5	4	10 000	11 000	18	K 42x47x13	–
	47	17	20,9	43	5,2	10 000	11 000	32	K 42x47x17	–
	47	30	31,9	76,5	9	10 000	11 000	54	K 42x47x30 ZW	–
	50	20	33,6	57	7,1	9 500	11 000	53	K 42x50x20	–
43	48	17	20,9	43	5,2	9 500	11 000	30	K 43x48x17	–
	48	27	31,9	76,5	9,3	9 500	11 000	50	K 43x48x27	–
45	50	17	21,6	46,5	5,6	9 000	10 000	34	K 45x50x17	–
	50	27	33	81,5	10	9 000	10 000	52	K 45x50x27	–
	52	18	30,3	57	6,95	9 000	10 000	42	K 45x52x18	G/SD 45x52x4
	53	20	37,4	68	8,3	9 000	10 000	55	K 45x53x20	–
	53	21	36,9	67	8,3	9 000	10 000	60	K 45x53x21	–
	53	28	49,5	98	12,2	9 000	10 000	81	K 45x53x28	–
	59	18	44	53	6,55	8 500	9 500	72	K 45x59x18 TN	–
59	32	69,3	102	12,9	8 500	9 500	148	K 45x59x32	–	

¹⁾ For additional information, visit skf.com/seals.

6.1 Needle roller and cage assemblies

F_w 47 – 155 mm

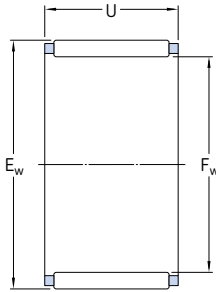

K

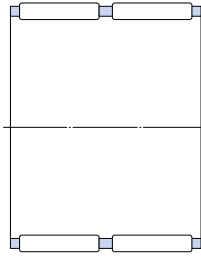

K..ZW

Principal dimensions			Basic load ratings		Fatigue load limit	Speed ratings		Mass	Designation	Appropriate seal ¹⁾
F _w	E _w	U	dynamic C	static C ₀	P _u	Reference speed	Limiting speed			Designation
mm			kN		kN	r/min		g	–	–
47	52	17	22,4	49	6	9 000	10 000	35		–
	52	27	33,6	83	10,2	9 000	10 000	51	K 47x52x17 K 47x52x27	–
50	55	13,5	17,6	36,5	4,3	8 500	9 500	30	K 50x55x13.5	–
	55	17	23,8	55	6,55	8 500	9 500	35	K 50x55x17	–
	55	20	25,5	60	7,2	8 500	9 500	43	K 50x55x20	–
	55	30	37,4	98	12	8 500	9 500	65	K 50x55x30	–
	57	18	31,9	64	7,8	8 000	9 000	47	K 50x57x18	–
	58	20	34,1	62	7,65	8 000	9 000	75	K 50x58x20	G/SD 50x58x4
	58	25	41,8	81,5	10,2	8 000	9 000	90	K 50x58x25	G/SD 50x58x4
52	57	12	17,2	36,5	4,3	8 000	9 000	24	K 52x57x12	–
55	60	20	27	67	8,15	7 500	8 500	40	K 55x60x20	–
	60	27	35,8	96,5	12	7 500	8 500	60	K 55x60x27	–
	60	30	39,6	108	13,4	7 500	8 500	71	K 55x60x30	–
	62	18	34,1	71	8,5	7 500	8 500	52	K 55x62x18	–
	63	20	38	75	9,15	7 500	8 500	67	K 55x63x20	G 55x63x5
	63	25	49,5	104	12,9	7 500	8 500	80	K 55x63x25	G 55x63x5
	63	32	59,4	129	16,3	7 500	8 500	102	K 55x63x32	G 55x63x5
58	65	18	33,6	71	8,65	7 000	8 000	52	K 58x65x18	–
	65	36	47,3	108	12,9	7 000	8 000	127	K 58x65x36 ZW	–
60	65	20	28,1	72	8,8	7 000	8 000	52	K 60x65x20	–
	65	30	41,3	116	14,3	7 000	8 000	77	K 60x65x30	–
	66	33	44	112	13,7	7 000	8 000	104	K 60x66x33 ZW	–
	66	40	55	150	18,6	7 000	8 000	116	K 60x66x40 ZW	–
	68	20	41,8	86,5	10,6	6 700	7 500	71	K 60x68x20	–
	68	23	47,3	102	12,5	6 700	7 500	94	K 60x68x23	–
	68	25	51,2	112	14	6 700	7 500	89	K 60x68x25	–
	68	30	42,9	88	10,6	6 700	7 500	129	K 60x68x30 ZW	–
	75	42	112	196	25	6 300	7 500	240	K 60x75x42	–
62	70	40	62,7	146	18	6 700	7 500	174	K 62x70x40 ZW	–

¹⁾ For additional information, visit skf.com/seals.

Principal dimensions			Basic load ratings		Fatigue load limit P_u	Speed ratings		Mass g	Designation	Appropriate seal ¹⁾ Designation
F_w	E_w	U	dynamic C	static C_0		Reference speed	Limiting speed			
mm			kN		kN	r/min		g	–	–
64	70	16	26,4	60	7,35	6 300	7 500	53	K 64x70x16	–
65	70	20	29,2	76,5	9,3	6 300	7 500	56	K 65x70x20	–
	70	30	41,8	125	15,3	6 300	7 500	83	K 65x70x30	–
	73	23	44	95	11,6	6 300	7 000	108	K 65x73x23	–
	73	30	53,9	125	15,6	6 300	7 000	141	K 65x73x30	–
68	74	20	33,6	83	10,4	6 000	7 000	71	K 68x74x20	–
	74	30	44,6	118	15	6 000	7 000	100	K 68x74x30	–
	74	35	46,8	125	15,3	6 000	7 000	120	K 68x74x35 ZW	–
70	76	20	34,1	86,5	10,6	6 000	6 700	71	K 70x76x20	–
	76	30	50,1	140	17,6	6 000	6 700	110	K 70x76x30	–
	78	30	57,2	137	17	6 000	6 700	148	K 70x78x30	G 70x78x5
72	80	20	39,6	85	10,6	5 600	6 300	98	K 72x80x20	–
73	79	20	35,2	90	11,2	5 600	6 300	75	K 73x79x20	–
75	81	20	35,8	93	11,6	5 600	6 300	79	K 75x81x20	–
	81	30	50,1	143	18	5 600	6 300	114	K 75x81x30	–
	83	23	47,3	110	13,7	5 300	6 300	124	K 75x83x23	–
	83	30	59,4	143	18	5 300	6 300	147	K 75x83x30	–
	83	35	60,5	146	18	5 300	6 300	182	K 75x83x35 ZW	–
	83	40	69,3	176	22	5 300	6 300	211	K 75x83x40 ZW	–
80	86	20	36,9	98	12,2	5 300	6 000	60	K 80x86x20	–
	88	30	68,2	176	22	5 000	6 000	138	K 80x88x30	–
	88	40	72,1	193	23,6	5 000	6 000	227	K 80x88x40 ZW	–
	88	46	84,2	232	28,5	5 000	6 000	260	K 80x88x46 ZW	–
85	92	20	42,9	108	13,2	4 800	5 600	102	K 85x92x20	–
90	97	20	42,9	114	13,7	4 500	5 300	109	K 90x97x20	–
	98	27	58,3	150	18,6	4 500	5 300	150	K 90x98x27	–
	98	30	64,4	173	21,6	4 500	5 300	172	K 90x98x30	–
95	103	30	66	180	22,8	4 300	5 000	165	K 95x103x30	–
	103	40	79,2	228	28,5	4 300	5 000	266	K 95x103x40 ZW	–
100	107	21	45,7	127	15,3	4 000	4 800	120	K 100x107x21	–
	108	27	55	143	17,6	4 000	4 800	185	K 100x108x27	–
	108	30	67,1	190	23,6	4 000	4 800	180	K 100x108x30	–
105	112	21	45,7	129	15,3	4 000	4 500	129	K 105x112x21	–
110	117	24	53,9	160	18,6	3 800	4 300	172	K 110x117x24	–
	118	30	73,7	220	26,5	3 800	4 300	217	K 110x118x30	–
115	123	27	60,5	170	20	3 600	4 000	200	K 115x123x27	–
120	127	24	56,1	176	20,4	3 400	4 000	165	K 120x127x24	–
125	133	35	82,5	260	30,5	3 200	3 800	275	K 125x133x35	–
130	137	24	58,3	186	21,2	3 200	3 600	170	K 130x137x24	–
135	143	35	88	290	33,5	3 000	3 400	300	K 135x143x35	–
145	153	26	70,4	224	25	2 800	3 200	262	K 145x153x26	–
150	160	46	140	475	53	2 800	3 000	570	K 150x160x46	–
155	163	26	72,1	236	25,5	2 600	3 000	265	K 155x163x26	–

¹⁾ For additional information, visit skf.com/seals.

6.1 Needle roller and cage assemblies

F_w 160 – 265 mm

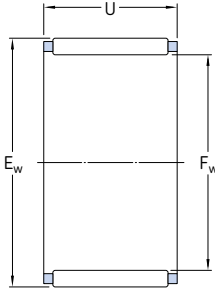

Principal dimensions			Basic load ratings		Fatigue load limit	Speed ratings		Mass	Designation
F _w	E _w	U	dynamic C	static C ₀	P _u	Reference speed	Limiting speed		
mm			kN		kN	r/min		g	-
160	170	46	145	510	56	2 600	2 800	550	K 160x170x46
165	173	26	76,5	265	28,5	2 400	2 800	320	K 165x173x26
175	183	32	95,2	355	37,5	2 400	2 600	400	K 175x183x32
185	195	37	123	425	45	2 200	2 400	607	K 185x195x37
195	205	37	125	450	46,5	2 000	2 400	620	K 195x205x37
210	220	42	147	560	57	1 900	2 200	740	K 210x220x42
220	230	42	151	585	58,5	1 800	2 000	790	K 220x230x42
240	250	42	157	630	62	1 700	1 900	850	K 240x250x42
265	280	50	242	850	83	1 500	1 700	1 810	K 265x280x50

6.2 Drawn cup needle roller bearings

F_w 3 – 9 mm

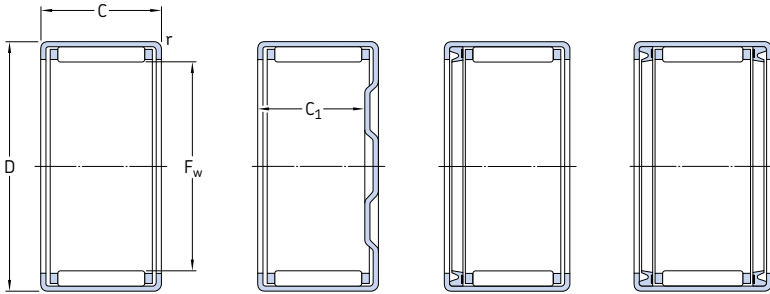

HK

BK

HK .. RS

HK ...2RS

F_w	Principal dimensions		Basic load ratings		Fatigue load limit P_u	Speed ratings		Mass	Designation
	D	C	C	C_0		Reference speed	Limiting speed		
mm			kN		kN	r/min		g	-
3	6,5	6	1,23	0,88	0,088	24 000	26 000	1	HK 0306 TN
	6,5	6	1,23	0,88	0,088	24 000	26 000	1	BK 0306 TN
4	8	8	1,76	1,37	0,14	22 000	26 000	2	HK 0408
	8	8	1,76	1,37	0,14	22 000	26 000	2,1	BK 0408
5	9	9	2,38	2,08	0,22	22 000	24 000	2	HK 0509
	9	9	2,38	2,08	0,22	22 000	24 000	2,1	BK 0509
6	10	6	1,72	1,29	0,132	20 000	22 000	1,5	HK 0606
	10	8	2,01	1,73	0,18	20 000	22 000	2,1	HK 0608
	10	9	2,81	2,7	0,285	20 000	22 000	2,5	HK 0609
	10	9	2,81	2,7	0,285	20 000	22 000	2,6	BK 0609
7	11	9	3,03	3,05	0,325	20 000	22 000	2,6	HK 0709
	11	9	3,03	3,05	0,325	20 000	22 000	2,9	BK 0709
8	12	8	2,7	2,75	0,285	19 000	22 000	2,7	HK 0808
	12	8	4,84	6,95	0,75	16 000	19 000	3	HN 0808
	12	8	2,7	2,75	0,285	19 000	22 000	3	BK 0808
	12	10	3,69	4,05	0,44	19 000	22 000	3	HK 0810
12	12	10	2,7	2,75	0,285	-	13 000	3	HK 0810 RS
	12	10	3,69	4,05	0,44	19 000	22 000	3,4	BK 0810
	12	12	3,69	4,05	0,44	-	13 000	3,1	HK 0812 RS
	12	12	2,7	2,75	0,285	-	13 000	3,3	HK 0812.2RS
	13	8	3,52	3,9	0,415	18 000	20 000	3	HK 0908
	13	10	4,13	4,8	0,53	18 000	20 000	4	HK 0910
13	13	10	4,13	4,8	0,53	18 000	20 000	4,3	BK 0910
	13	12	5,12	6,4	0,72	18 000	20 000	4,6	HK 0912
	13	12	5,12	6,4	0,72	18 000	20 000	4,9	BK 0912
	13	12	5,12	6,4	0,72	18 000	20 000	4,9	BK 0912

Dimensions			Appropriate inner ring ¹⁾ Designation	Appropriate seal ²⁾ Designation
F _w	C ₁ min.	r min.		
mm			-	-
3	-	0,3	-	-
	5,2	0,3	-	-
4	-	0,4	-	G 4x8x2 S
	6,4	0,3	-	G 4x8x2 S
5	-	0,4	-	G 5x9x2 S
	7,4	0,4	-	G 5x9x2 S
6	-	0,4	-	G 6x10x2 S
	-	0,4	-	G 6x10x2 S
	-	0,4	-	G 6x10x2 S
	7,4	0,4	-	G 6x10x2 S
7	-	0,4	-	G 7x11x2 S
	7,4	0,4	-	G 7x11x2 S
8	-	0,4	-	G 8x12x3
	-	0,4	-	-
	6,4	0,4	-	G 8x12x3
	-	0,4	IR 5x8x12	G 8x12x3
	-	0,4	-	-
	8,4	0,4	IR 5x8x12	G 8x12x3
	-	0,4	-	-
	-	0,4	-	-
9	-	0,4	-	G 9x13x3
	-	0,4	-	G 9x13x3
	8,4	0,4	-	G 9x13x3
	-	0,4	IR 6x9x12	G 9x13x3
	10,4	0,4	IR 6x9x12	G 9x13x3

¹⁾ For additional information, refer to *Needle roller bearing inner rings* (→ page 691).

²⁾ For additional information, visit skf.com/seals.

6.2 Drawn cup needle roller bearings

F_w 10 – 14 mm

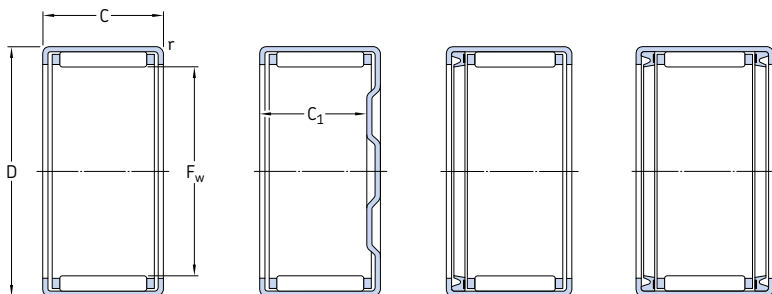

HK

BK

HK .. RS

HK ...2RS

F_w	Principal dimensions		Basic load ratings		Fatigue load limit P_u	Speed ratings		Mass g	Designation
	D	C	C	C_0		Reference speed	Limiting speed		
mm			kN		kN	r/min			-
10	14	10	4,29	5,3	0,57	18 000	20 000	4,1	HK 1010
	14	10	6,82	11,4	1,27	14 000	18 000	4,6	HN 1010
	14	10	4,29	5,3	0,57	18 000	20 000	4,3	BK 1010
	14	12	5,39	6,95	0,78	18 000	20 000	4,8	HK 1012
	14	12	4,29	5,3	0,57	-	12 000	4,2	HK 1012 RS
	14	12	3,19	3,55	0,365	-	12 000	4,3	HK 1012.2RS
	14	12	5,39	6,95	0,78	18 000	20 000	5	BK 1012
	14	12	4,29	5,3	0,57	-	12 000	4,3	BK 1012 RS
	14	14	4,29	5,3	0,57	-	12 000	4,6	HK 1014.2RS
	14	15	6,6	9	1,02	18 000	20 000	6	HK 1015
	14	15	6,6	9	1,02	18 000	20 000	6,2	BK 1015
	12	16	10	4,84	6,4	0,71	16 000	18 000	4,6
16		10	7,48	13,7	1,53	13 000	17 000	5,3	HN 1210
16		10	4,84	6,4	0,71	16 000	18 000	5,2	BK 1210
18		12	6,27	7,35	0,85	16 000	18 000	9	HK 1212
18		12	9,52	15,3	1,76	13 000	17 000	10,5	HN 1212
18		12	6,27	7,35	0,85	16 000	18 000	10	BK 1212
18		14	6,27	7,35	0,85	-	10 000	10	HK 1214 RS
16		14	4,84	6,4	0,71	-	10 000	8	HK 1214.2RS
18		16	6,27	7,35	0,85	-	10 000	11	HK 1216.2RS
13		19	12	6,6	8	0,915	16 000	17 000	10
	19	12	6,6	8	0,915	16 000	17 000	11	BK 1312
14	20	12	6,82	8,65	0,98	15 000	17 000	10,5	HK 1412
	20	12	10,5	17,6	2,04	12 000	15 000	12	HN 1412
	20	12	6,82	8,65	0,98	15 000	17 000	12	BK 1412
	20	14	6,82	8,65	0,98	-	9 500	12	HK 1414 RS
	20	14	6,82	8,65	0,98	-	9 500	13	BK 1414 RS
	20	16	6,82	8,65	0,98	-	9 500	13	HK 1416.2RS
	20	16	6,82	8,65	0,98	-	9 500	13	BK 1416.2RS

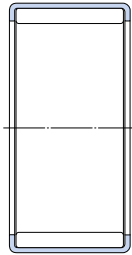
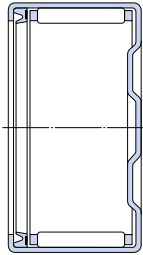

BK..RS

HN

6.2

Dimensions			Appropriate inner ring ¹⁾ Designation	Appropriate seal ²⁾ Designation
F _w	C ₁ min.	r min.		
mm			-	-
10	-	0,4	LR/IR 7x10x10.5	G 10x14x3
	-	0,4	LR/IR 7x10x10.5	G 10x14x3
	8,4	0,4	LR/IR 7x10x10.5	G 10x14x3
	-	0,4	IR 7x10x12	G 10x14x3
	-	0,4	-	-
	-	0,4	-	-
	10,4	0,4	IR 7x10x12	G 10x14x3
	10,4	0,4	-	-
	-	0,4	-	-
	-	0,4	IR 7x10x16	G 10x14x3
13,4	0,4	IR 7x10x16	G 10x14x3	
12	-	0,4	LR/IR 8x12x10.5	G 12x16x3
	-	0,4	LR/IR 8x12x10.5	G 12x16x3
	8,4	0,4	LR/IR 8x12x10.5	G 12x16x3
	-	0,8	LR/IR 8x12x12.5	G/SD 12x18x3
	-	0,8	LR/IR 8x12x12.5	G/SD 12x18x3
	9,3	0,8	LR/IR 8x12x12.5	G/SD 12x18x3
	-	0,8	-	-
	-	0,8	-	-
13	-	0,8	LR/IR 10x13x12.5	G 13x19x3
	9,3	0,8	LR/IR 10x13x12.5	G 13x19x3
14	-	0,8	IR 10x14x13	G/SD 14x20x3
	-	0,8	IR 10x14x13	G/SD 14x20x3
	9,3	0,8	IR 10x14x13	G/SD 14x20x3
	-	0,8	-	-
	11,3	0,8	-	-
-	0,8	-	-	

¹⁾ For additional information, refer to *Needle roller bearing inner rings* (→ page 691).

²⁾ For additional information, visit skf.com/seals.

6.2 Drawn cup needle roller bearings

F_w 15 – 18 mm

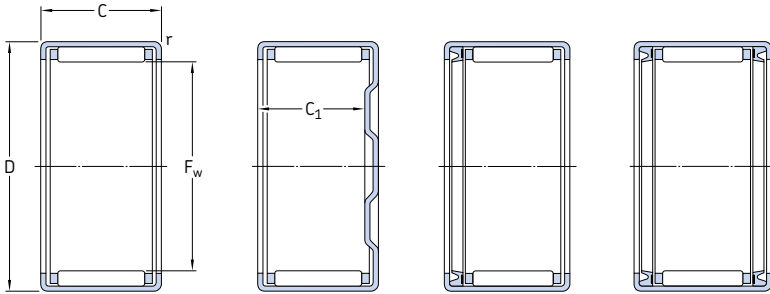

HK

BK

HK..RS

HK...2RS

F_w	Principal dimensions		Basic load ratings		Fatigue load limit P_u	Speed ratings		Mass g	Designation
	D	C	C	C_0		Reference speed	Limiting speed		
mm			kN		kN	r/min			-
15	21	12	7,65	9,5	1,08	15 000	16 000	11	HK 1512
	21	12	7,65	9,5	1,08	15 000	16 000	13	BK 1512
	21	14	7,48	10	1,14	-	9 500	12	HK 1514 RS
	21	14	7,48	10	1,14	-	9 500	14	BK 1514 RS
	21	16	10,1	14,6	1,7	15 000	16 000	15	HK 1516
	21	16	7,48	10	1,14	-	9 500	15	HK 1516.2RS
	21	16	14,5	28	3,25	12 000	15 000	14	HN 1516
	21	16	10,1	14,6	1,7	15 000	16 000	17	BK 1516
	21	18	10,1	14,6	1,7	-	9 500	16	HK 1518 RS
	21	20	10,1	14,6	1,7	-	9 500	18	HK 1520.2RS
	21	22	13	20	2,28	15 000	16 000	20	HK 1522
	16	22	12	7,37	9,8	1,12	14 000	16 000	12
22		12	11,2	20,4	2,32	12 000	15 000	13	HN 1612
22		12	7,37	9,8	1,12	14 000	16 000	14	BK 1612
22		14	7,37	9,8	1,12	-	9 000	13	HK 1614 RS
22		14	7,37	9,8	1,12	-	9 000	15	BK 1614 RS
22		16	10,5	15,6	1,8	14 000	16 000	16	HK 1616
22		16	7,37	9,8	1,12	-	9 000	14	HK 1616.2RS
22		16	10,5	15,6	1,8	14 000	16 000	18	BK 1616
22		20	10,5	15,6	1,8	-	9 000	18	HK 1620.2RS
22		22	12,8	19,6	2,24	14 000	16 000	24	HK 1622 ¹⁾
22		22	12,8	19,6	2,24	14 000	16 000	24	BK 1622 ¹⁾
22		22	12,8	19,6	2,24	14 000	16 000	24	BK 1622 ¹⁾
17	23	12	7,65	10,6	1,2	14 000	15 000	12	HK 1712
	23	12	7,65	10,6	1,2	14 000	15 000	12	HK 1712
18	24	12	7,92	11,2	1,27	13 000	15 000	13	HK 1812
	24	12	7,92	11,2	1,27	13 000	15 000	15	BK 1812
	24	14	7,92	11,2	1,27	-	8 500	14	HK 1814 RS
	24	16	11,2	17,6	2,04	13 000	15 000	18	HK 1816
	24	16	7,92	11,2	1,27	-	8 500	15	HK 1816.2RS
	24	16	16,1	33,5	3,8	11 000	14 000	20	HN 1816
	24	16	11,2	17,6	2,04	13 000	15 000	20	BK 1816
	24	16	11,2	17,6	2,04	13 000	15 000	20	BK 1816
	24	16	11,2	17,6	2,04	13 000	15 000	20	BK 1816
	24	16	11,2	17,6	2,04	13 000	15 000	20	BK 1816

¹⁾ Double row, outer ring with a lubrication hole

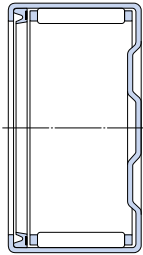

BK ..RS

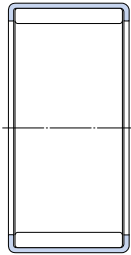

HN

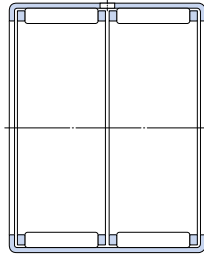
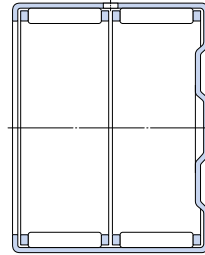
HK
(double row)BK
(double row)

Dimensions			Appropriate inner ring ¹⁾ Designation	Appropriate seal ²⁾ Designation
F _w	C ₁ min.	r min.		
mm			-	-
15	-	0,8	LR/IR 12x15x12.5	G/SD 15x21x3
	9,3	0,8	LR/IR 12x15x12.5	G/SD 15x21x3
	-	0,8	LR/IR 12x15x16.5	-
	11,3	0,8	LR/IR 12x15x16.5	-
	-	0,8	LR/IR 12x15x16.5	G/SD 15x21x3
	-	0,8	LR/IR 12x15x16.5	-
	-	0,8	LR/IR 12x15x16.5	G/SD 15x21x3
	13,3	0,8	LR/IR 12x15x16.5	G/SD 15x21x3
	-	0,8	-	-
	-	0,8	-	-
	-	0,8	LR/IR 12x15x22.5	G/SD 15x21x3
16	-	0,8	IR 12x16x13	G/SD 16x22x3
	-	0,8	IR 12x16x13	G/SD 16x22x3
	9,3	0,8	IR 12x16x13	G/SD 16x22x3
	-	0,8	IR 12x16x20	-
	11,3	0,8	IR 12x16x20	-
	-	0,8	IR 12x16x16	G/SD 16x22x3
	-	0,8	IR 12x16x20	-
	13,3	0,8	IR 12x16x16	G/SD 16x22x3
	-	0,8	-	-
	-	0,8	IR 12x16x22	G/SD 16x22x3
	19,3	0,8	IR 12x16x22	G/SD 16x22x3
17	-	0,8	-	G/SD 17x23x3
	-	0,8	-	-
18	-	0,8	LR 15x18x12.5	G/SD 18x24x3
	9,3	0,8	LR 15x18x12.5	G/SD 18x24x3
	-	0,8	LR/IR 15x18x16.5	-
	-	0,8	LR/IR 15x18x16.5	G/SD 18x24x3
	-	0,8	LR/IR 15x18x16.5	-
	-	0,8	LR/IR 15x18x16.5	G/SD 18x24x3
	13,3	0,8	LR/IR 15x18x16.5	G/SD 18x24x3
	-	0,8	LR/IR 15x18x16.5	-

¹⁾ For additional information, refer to *Needle roller bearing inner rings* (→ page 691).

²⁾ For additional information, visit skf.com/seals.

6.2 Drawn cup needle roller bearings

F_w 20 – 22 mm

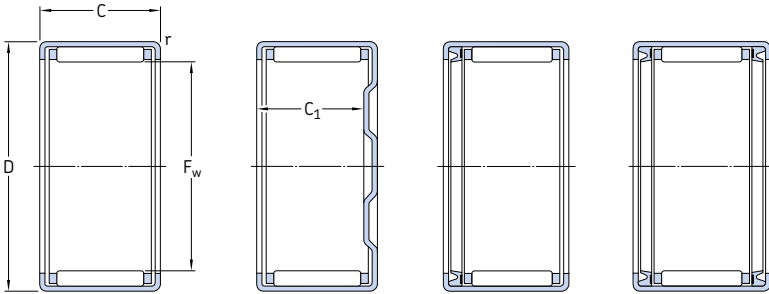

HK

BK

HK..RS

HK...2RS

Principal dimensions	Basic load ratings		Fatigue load limit	Speed ratings		Mass	Designation		
	dynamic	static		Reference speed	Limiting speed				
F _w	D	C	C	C ₀	P _u				
mm			kN		kN	r/min	g	-	
20	26	10	6,16	8,5	0,93	12 000	14 000	12	HK 2010
	26	12	8,42	12,5	1,4	12 000	14 000	14	HK 2012
	26	16	12,3	20,4	2,36	12 000	14 000	19	HK 2016
	26	16	8,42	12,5	1,4	-	8 000	18	HK 2016.2RS
	26	16	16,8	36,5	4,25	10 000	12 000	22	HN 2016
	26	16	12,3	20,4	2,36	12 000	14 000	22	BK 2016
	26	18	12,3	20,4	2,36	-	8 000	21	HK 2018 RS
	26	18	12,3	20,4	2,36	-	8 000	24	BK 2018 RS
	26	20	15,1	26,5	3,15	12 000	14 000	24	HK 2020
	26	20	12,3	20,4	2,36	-	8 000	23	HK 2020.2RS
	26	20	20,9	48	5,7	10 000	12 000	29,5	HN 2020
	26	20	15,1	26,5	3,15	12 000	14 000	27	BK 2020
	26	30	20,9	40,5	4,75	12 000	14 000	35	HK 2030 ¹⁾
	22	28	10	7,21	10,6	1,2	11 000	12 000	13
28		12	8,8	13,7	1,56	11 000	12 000	15	HK 2212
28		12	8,8	13,7	1,56	11 000	12 000	18	BK 2212
28		14	8,8	13,7	1,56	-	7 500	16	HK 2214 RS
28		16	13	22,4	2,6	11 000	12 000	21	HK 2216
28		16	8,8	13,7	1,56	-	7 500	18	HK 2216.2RS
28		16	13	22,4	2,6	11 000	12 000	24	BK 2216
28		18	13	22,4	2,6	-	7 500	24	HK 2218 RS
28		20	15,7	29	3,45	11 000	12 000	26	HK 2220
28		20	13	22,4	2,6	-	7 500	23	HK 2220.2RS

¹⁾ Double row, outer ring with a lubrication hole

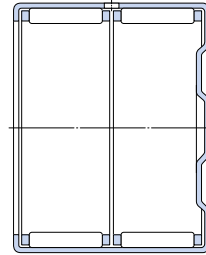
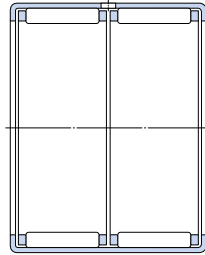
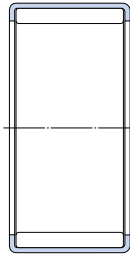
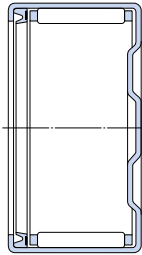

BK ..RS

HN

HK
(double row)BK
(double row)

6.2

Dimensions			Appropriate inner ring ¹⁾ Designation	Appropriate seal ²⁾ Designation
F _w	C ₁ min.	r min.		
mm			-	-
20	-	0,8	-	G/SD 20x26x4
	-	0,8	IR 15x20x13	G/SD 20x26x4
	-	0,8	LR/IR 17x20x16.5	G/SD 20x26x4
	-	0,8	LR/IR 17x20x16.5	-
	-	0,8	LR/IR 17x20x16.5	G/SD 20x26x4
	13,3	0,8	LR/IR 17x20x16.5	G/SD 20x26x4
	-	0,8	LR/IR 17x20x20.5	-
	15,3	0,8	LR/IR 17x20x20.5	-
	-	0,8	LR/IR 17x20x20.5	G/SD 20x26x4
	-	0,8	LR/IR 17x20x20.5	-
	-	0,8	LR/IR 17x20x20.5	G/SD 20x26x4
	17,3	0,8	LR/IR 17x20x20.5	G/SD 20x26x4
	-	0,8	LR/IR 17x20x30.5	G/SD 20x26x4
	22	-	0,8	-
-		0,8	IR 17x22x13	G/SD 22x28x4
9,3		0,8	IR 17x22x13	G/SD 22x28x4
-		0,8	IR 17x22x23	-
-		0,8	IR 17x22x23	G/SD 22x28x4
-		0,8	IR 17x22x23	-
13,3		0,8	IR 17x22x16	G/SD 22x28x4
-		0,8	IR 17x22x23	-
-		0,8	IR 17x22x23	G/SD 22x28x4
-		0,8	IR 17x22x23	-
-		0,8	IR 17x22x23	-

¹⁾ For additional information, refer to *Needle roller bearing inner rings* (→ page 691).

²⁾ For additional information, visit skf.com/seals.

6.2 Drawn cup needle roller bearings

F_w 25 – 28 mm

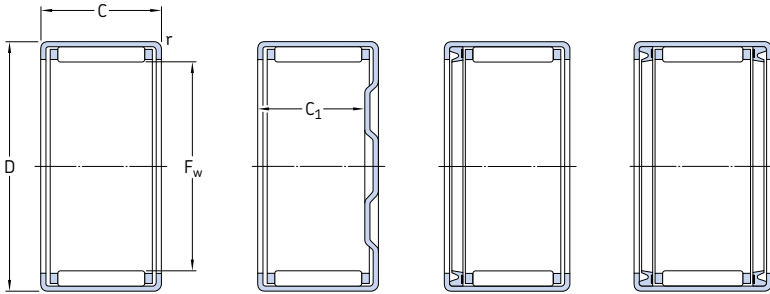

HK

BK

HK .. RS

HK ...2RS

Principal dimensions	Basic load ratings		Fatigue load limit	Speed ratings		Mass	Designation		
	dynamic	static		Reference speed	Limiting speed				
F _w	D	C	C	C ₀	P _u				
mm			kN		kN	r/min	g	-	
25	32	12	10,5	15,3	1,76	9 500	11 000	20	HK 2512
	32	16	15,1	24	2,85	9 500	11 000	27	HK 2516
	32	16	10,5	15,3	1,76	-	6 700	27	HK 2516 .2RS
	32	16	15,1	24	2,85	9 500	11 000	32	BK 2516
	32	18	15,1	24	2,85	-	6 700	29	HK 2518 RS
	32	18	15,1	24	2,85	-	6 700	34	BK 2518 RS
	32	20	19	32,5	4	9 500	11 000	33	HK 2520
	32	20	15,1	24	2,85	-	6 700	31	HK 2520 .2RS
	32	20	26,4	60	7,2	8 000	10 000	39,5	HN 2520
	32	20	19	32,5	4	9 500	11 000	38	BK 2520
	32	24	19	32,5	4	-	6 700	40	HK 2524 .2RS
	32	26	24,2	45	5,5	9 500	11 000	44	HK 2526
	32	26	24,2	45	5,5	9 500	11 000	48	BK 2526
	32	30	24,2	45	5,5	-	6 700	47	HK 2530 .2RS
32	38	33	65,5	8	9 500	11 000	64	HK 2538 ¹⁾	
32	38	33	65,5	8	9 500	11 000	68	BK 2538 ¹⁾	
28	35	16	15,7	26,5	3,15	9 000	9 500	29	HK 2816
	35	18	15,7	26,5	3,15	-	6 300	31	HK 2818 RS
	35	20	20,1	36,5	4,4	9 000	9 500	36	HK 2820
	35	20	15,7	26,5	3,15	-	6 300	34	HK 2820 .2RS
	35	20	28,1	68	8,15	7 000	9 000	44	HN 2820

¹⁾ Double row, outer ring with a lubrication hole

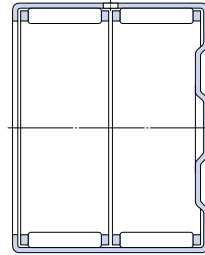
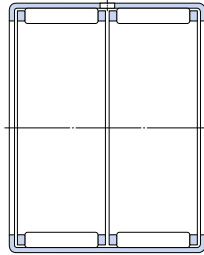
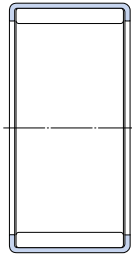
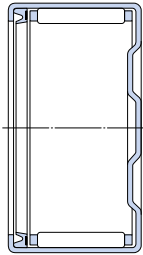

BK ..RS

HN

HK
(double row)BK
(double row)

6.2

Dimensions			Appropriate inner ring ¹⁾ Designation	Appropriate seal ²⁾ Designation
F _w	C ₁ min.	r min.		
mm			–	–
25	–	0,8	LR 20x25x12.5	G 25x32x4
	–	0,8	IR 20x25x17 / LR 20x25x16.5	G 25x32x4
	–	0,8	IR 20x25x17 / LR 20x25x16.5	–
	13,3	0,8	IR 20x25x17 / LR 20x25x16.5	–
	–	0,8	LR/IR 20x25x20.5	–
	15,3	0,8	LR/IR 20x25x20.5	–
	–	0,8	LR/IR 20x25x20.5	G 25x32x4
	–	0,8	LR/IR 20x25x20.5	–
	–	0,8	LR/IR 20x25x20.5	G 25x32x4
	17,3	0,8	LR/IR 20x25x20.5	G 25x32x4
	–	0,8	–	–
	–	0,8	LR/IR 20x25x26.5	G 25x32x4
	23,3	0,8	LR/IR 20x25x26.5	G 25x32x4
	–	0,8	IR 20x25x30	–
–	0,8	LR/IR 20x25x38.5	G 25x32x4	
35,3	0,8	LR/IR 20x25x38.5	G 25x32x4	
28	–	0,8	IR 22x28x17	G/SD 28x35x4
	–	0,8	LR/IR 22x28x20.5	–
	–	0,8	LR/IR 22x28x20.5	G/SD 28x35x4
	–	0,8	LR/IR 22x28x20.5	–
	–	0,8	LR/IR 22x28x20.5	G/SD 28x35x4

¹⁾ For additional information, refer to *Needle roller bearing inner rings* (→ page 691).

²⁾ For additional information, visit skf.com/seals.

6.2 Drawn cup needle roller bearings

F_w 30 – 35 mm

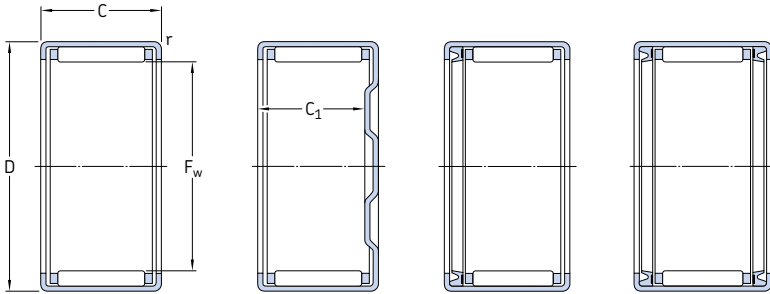

HK

BK

HK..RS

HK...2RS

F_w	Principal dimensions		Basic load ratings		Fatigue load limit	Speed ratings		Mass	Designation
	D	C	C	C_0	P_u	Reference speed	Limiting speed		
mm			kN		kN	r/min		g	-
30	37	12	11,7	18,3	2,12	8 000	9 000	23	HK 3012
	37	12	11,7	18,3	2,12	8 000	9 000	28	BK 3012
	37	16	16,5	29	3,4	8 000	9 000	31	HK 3016
	37	16	11,7	18,3	2,12	-	5 600	31	HK 3016.2RS
	37	16	16,5	29	3,4	8 000	9 000	38	BK 3016
	37	18	16,5	29	3,4	-	5 600	37	HK 3018 RS
	37	20	20,9	40	4,75	8 000	9 000	39	HK 3020
	37	20	16,5	29	3,4	-	5 600	36	HK 3020.2RS
	37	20	20,9	40	4,75	8 000	9 000	47	BK 3020
	37	22	23,8	46,5	5,6	8 000	9 000	42	HK 3022
	37	24	20,9	40	4,75	-	5 600	44	HK 3024.2RS
	37	26	27	54	6,55	8 000	9 000	51	HK 3026
	37	26	27	54	6,55	8 000	9 000	58	BK 3026
	37	38	35,8	80	9,5	8 000	9 000	76	HK 3038 ¹⁾
37	38	35,8	80	9,5	8 000	9 000	84	BK 3038 ¹⁾	
32	39	20	22	43	5,2	7 500	8 500	40,5	HK 3220
	39	24	26,4	54	6,55	7 500	8 500	49	HK 3224
35	42	12	12,5	21,6	2,45	7 000	8 000	27	HK 3512
	42	16	17,9	34	4	7 000	8 000	36	HK 3516
	42	16	12,5	21,6	2,45	-	5 000	32	HK 3516.2RS
	42	18	17,9	34	4	-	5 000	39	HK 3518 RS
	42	20	22,9	46,5	5,6	7 000	8 000	44	HK 3520
	42	20	17,9	34	4	-	5 000	41	HK 3520.2RS
	42	20	31,4	83	10,2	6 000	7 500	54	HN 3520
	42	20	22,9	46,5	5,6	7 000	8 000	53	BK 3520

¹⁾ Double row, outer ring with a lubrication hole

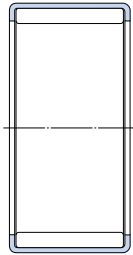

HN

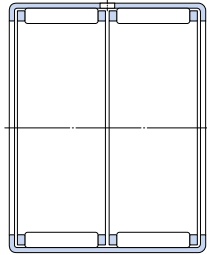
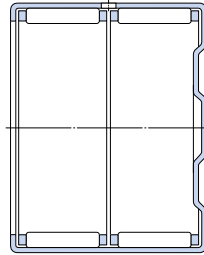
HK
(double row)BK
(double row)

6.2

Dimensions			Appropriate inner ring ¹⁾ Designation	Appropriate seal ²⁾ Designation
F _w	C ₁ min.	r min.		
mm			-	-
30	-	0,8	LR 25x30x12.5	G/SD 30x37x4
	9,3	0,8	LR 25x30x12.5	G/SD 30x37x4
	-	0,8	IR 25x30x17 / LR 25x30x16.5	G/SD 30x37x4
	-	0,8	IR 25x30x17 / LR 25x30x16.5	-
	13,3	0,8	IR 25x30x17 / LR 25x30x16.5	G/SD 30x37x4
	-	0,8	LR/IR 25x30x20.5	-
	-	0,8	LR/IR 25x30x20.5	G/SD 30x37x4
	-	0,8	LR/IR 25x30x20.5	-
	17,3	0,8	LR/IR 25x30x20.5	G/SD 30x37x4
	-	0,8	-	G/SD 30x37x4
	-	0,8	-	-
	-	0,8	LR/IR 25x30x26.5	G/SD 30x37x4
	23,3	0,8	LR/IR 25x30x26.5	G/SD 30x37x4
	-	0,8	LR/IR 25x30x38.5	G/SD 30x37x4
	35,3	0,8	LR/IR 25x30x38.5	G/SD 30x37x4
32	-	0,8	LR 28x32x20	-
	-	0,8	-	-
35	-	0,8	LR 30x35x12.5	G/SD 35x42x4
	-	0,8	IR 30x35x17 / LR 30x35x16.5	G/SD 35x42x4
	-	0,8	IR 30x35x17 / LR 30x35x16.5	-
	-	0,8	LR/IR 30x35x20.5	-
	-	0,8	LR/IR 30x35x20.5	G/SD 35x42x4
	-	0,8	LR/IR 30x35x20.5	-
	-	0,8	LR/IR 30x35x20.5	G/SD 35x42x4
	17,3	0,8	LR/IR 30x35x20.5	G/SD 35x42x4

¹⁾ For additional information, refer to *Needle roller bearing inner rings* (→ page 691).

²⁾ For additional information, visit skf.com/seals.

6.2 Drawn cup needle roller bearings

F_w 40 – 60 mm

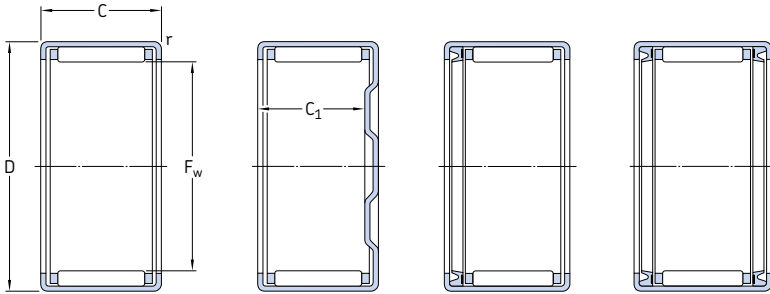

HK

BK

HK .. RS

HK ...2RS

Principal dimensions	Basic load ratings		Fatigue load limit	Speed ratings		Mass	Designation		
	dynamic	static		Reference speed	Limiting speed				
F _w	D	C	C	C ₀	P _u				
mm	kN		kN		r/min	g	-		
40	47	12	13,4	24,5	2,8	6 300	7 000	30	HK 4012
	47	16	19	39	4,55	6 300	7 000	39	HK 4016
	47	16	14,5	27,5	3,15	-	4 500	37	HK 4016.2RS
	47	18	19	39	4,55	-	4 500	45	HK 4018 RS
	47	20	24,2	53	6,4	6 300	7 000	54	HK 4020
	47	20	19	39	4,55	-	4 500	48	HK 4020.2RS
	47	20	33,6	95	11,6	5 000	6 300	60,5	HN 4020
	47	20	24,2	53	6,4	6 300	7 000	62	BK 4020
45	52	12	14,2	27,5	3,2	5 600	6 300	33	HK 4512
	52	16	20,5	43	5,1	5 600	6 300	47	HK 4516
	52	18	20,5	43	5,1	-	4 000	50	HK 4518 RS
	52	20	26	60	7,2	5 600	6 300	56	HK 4520
	52	20	20,5	43	5,1	-	4 000	54	HK 4520.2RS
	52	20	35,8	108	13,2	4 500	5 600	66	HN 4520
	52	20	26	60	7,2	5 600	6 300	72	BK 4520
	52	25	44	140	17	4 500	5 600	85	HN 4525
50	58	20	29,2	63	7,8	5 000	5 600	70	HK 5020
	58	20	41,8	120	14,3	4 000	5 000	85,5	HN 5020
	58	22	29,2	63	7,8	-	3 600	76	HK 5022 RS
	58	24	29,2	63	7,8	-	3 600	81	HK 5024.2RS
	58	25	36,9	85	10,6	5 000	5 600	90	HK 5025
	58	25	50,1	153	18,6	4 000	5 000	107	HN 5025
55	63	20	30,3	67	8,3	4 500	5 000	74	HK 5520
	63	28	41,8	104	12,9	4 500	5 000	105	HK 5528
60	68	12	17,6	32	3,8	4 300	4 800	49	HK 6012
	68	20	31,9	75	9,3	4 300	4 800	81	HK 6020
	68	32	51,2	137	17	4 300	4 800	136	HK 6032

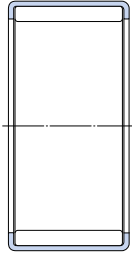

HN

6.2

Dimensions			Appropriate inner ring ¹⁾ Designation	Appropriate seal ²⁾ Designation
F _w	C ₁ min.	r min.		
mm				
40	–	0,8	LR 35x40x12.5	G/SD 40x47x4
	–	0,8	IR 35x40x20 / LR 35x40x16.5	G/SD 40x47x4
	–	0,8	IR 35x40x20 / LR 35x40x16.5	–
	–	0,8	LR/IR 35x40x20.5	–
	–	0,8	LR/IR 35x40x20.5	G/SD 40x47x4
	–	0,8	LR/IR 35x40x20.5	–
	17,3	0,8	LR/IR 35x40x20.5	G/SD 40x47x4
45	–	0,8	–	G/SD 45x52x4
	–	0,8	IR 40x45x17 / LR 40x45x16.5	G/SD 45x52x4
	–	0,8	LR/IR 40x45x20.5	–
	–	0,8	IR 40x45x20.5	G/SD 45x52x4
	–	0,8	LR/IR 40x45x20.5	–
	–	0,8	LR/IR 40x45x20.5	G/SD 45x52x4
	17,3	0,8	LR/IR 40x45x20.5	G/SD 45x52x4
50	–	0,8	LR 45x50x20.5	G/SD 50x58x4
	–	0,8	LR 45x50x20.5	G/SD 50x58x4
	–	0,8	LR/IR 45x50x25.5	–
	–	0,8	LR/IR 45x50x25.5	–
	–	0,8	LR/IR 45x50x25.5	G/SD 50x58x4
	–	0,8	LR/IR 45x50x25.5	G/SD 50x58x4
	–	0,8	LR/IR 45x50x25.5	–
55	–	0,8	LR 50x55x20.5	G 55x63x5
	–	0,8	–	G 55x63x5
60	–	0,8	–	–
	–	0,8	–	–
	–	0,8	–	–

¹⁾ For additional information, refer to *Needle roller bearing inner rings* (→ page 691).

²⁾ For additional information, visit skf.com/seals.

6.3 Needle roller bearings with machined rings with flanges, without an inner ring

F_w 5 – 17 mm

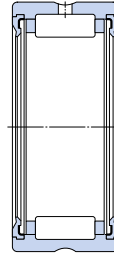
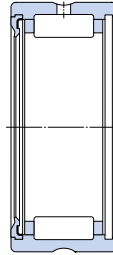
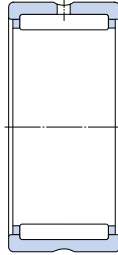
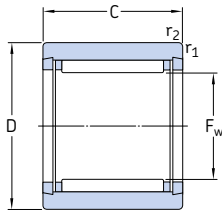

NK ($F_w \leq 10$ mm)

NK ($F_w \geq 12$ mm)
RNA 49
RNA 6901

RNA 49 .. RS

RNA 49 ...2RS

Principal dimensions			Basic load ratings		Fatigue load limit	Speed ratings		Mass	Designation
F_w	D	C	dynamic	static		Reference speed	Limiting speed		
mm			C	C_0	P_u	r/min		kg	–
5	10	10	2,29	2	0,212	36 000	40 000	0,0031	NK 5/10 TN
	10	12	2,92	2,7	0,29	36 000	40 000	0,0037	NK 5/12 TN
6	12	10	2,55	2,36	0,25	34 000	38 000	0,0047	NK 6/10 TN
	12	12	3,3	3,2	0,345	34 000	38 000	0,0057	NK 6/12 TN
7	14	10	2,81	2,75	0,29	32 000	36 000	0,0069	NK 7/10 TN
	14	12	3,58	3,75	0,415	32 000	36 000	0,0082	NK 7/12 TN
8	15	12	3,8	4,25	0,465	32 000	36 000	0,0087	NK 8/12 TN
	15	16	5,01	5,85	0,67	32 000	36 000	0,012	NK 8/16 TN
9	16	12	4,4	5,2	0,57	30 000	34 000	0,01	NK 9/12 TN
	16	16	5,72	7,2	0,815	30 000	34 000	0,013	NK 9/16 TN
10	17	12	4,57	5,7	0,63	28 000	32 000	0,01	NK 10/12 TN
	17	16	5,94	8	0,9	28 000	32 000	0,013	NK 10/16 TN
12	19	12	6,71	8,15	0,965	26 000	30 000	0,012	NK 12/12
	19	16	9,13	12	1,43	26 000	30 000	0,016	NK 12/16
14	22	13	8,8	10,4	1,22	24 000	28 000	0,017	RNA 4900
	22	13	7,37	8,15	0,965	–	12 000	0,016	RNA 4900 RS
	22	13	7,37	8,15	0,965	–	12 000	0,016	RNA 4900.2RS
	22	16	10,2	12,5	1,5	24 000	28 000	0,021	NK 14/16
	22	20	12,8	16,6	2	24 000	28 000	0,026	NK 14/20
15	23	16	11	14	1,66	24 000	26 000	0,022	NK 15/16
	23	20	13,8	18,3	2,2	24 000	26 000	0,027	NK 15/20
16	24	13	9,9	12,2	1,46	22 000	26 000	0,017	RNA 4901
	24	13	8,09	9,65	1,14	–	11 000	0,018	RNA 4901 RS
	24	13	8,09	9,65	1,14	–	11 000	0,018	RNA 4901.2RS
	24	16	11,7	15,3	1,8	22 000	26 000	0,022	NK 16/16
	24	20	14,5	20	2,4	22 000	26 000	0,028	NK 16/20
	24	22	16,1	23,2	2,75	22 000	26 000	0,031	RNA 6901
17	25	16	12,1	16,6	1,96	22 000	26 000	0,024	NK 17/16
	25	20	15,1	22	2,65	22 000	26 000	0,03	NK 17/20

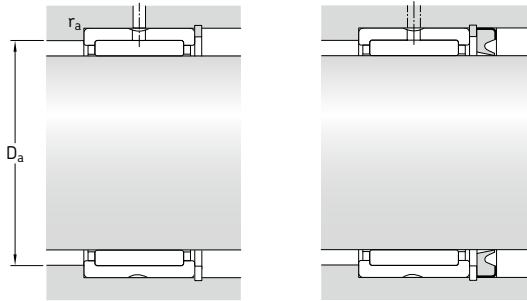

Dimensions		Abutment and fillet dimensions		Appropriate seal ¹⁾ Designation
F _w	r _{1,2} min.	D _a max.	r _a max.	
mm		mm		-
5	0,15	8,8	0,1	G 5x10x2 S
	0,15	8,8	0,1	G 5x10x2 S
6	0,15	10,8	0,1	G 6x12x2 S
	0,15	10,8	0,1	G 6x12x2 S
7	0,3	12	0,3	G 7x14x2
	0,3	12	0,3	G 7x14x2
8	0,3	13	0,3	G/SD 8x15x3
	0,3	13	0,3	G/SD 8x15x3
9	0,3	14	0,3	G 9x16x3
	0,3	14	0,3	G 9x16x3
10	0,3	15	0,3	G/SD 10x17x3
	0,3	15	0,3	G/SD 10x17x3
12	0,3	17	0,3	G/SD 12x19x3
	0,3	17	0,3	G/SD 12x19x3
14	0,3	20	0,3	G/SD 14x22x3
	0,3	20	0,3	-
	0,3	20	0,3	-
	0,3	20	0,3	G/SD 14x22x3
	0,3	20	0,3	G/SD 14x22x3
15	0,3	21	0,3	G/SD 15x23x3
	0,3	21	0,3	G/SD 15x23x3
16	0,3	22	0,3	G/SD 16x24x3
	0,3	22	0,3	-
	0,3	22	0,3	-
	0,3	22	0,3	G/SD 16x24x3
	0,3	22	0,3	G/SD 16x24x3
17	0,3	23	0,3	G/SD 17x25x3
	0,3	23	0,3	G/SD 17x25x3

¹⁾ For additional information, visit skf.com/seals.

6.3 Needle roller bearings with machined rings with flanges, without an inner ring

F_w 18 – 25 mm

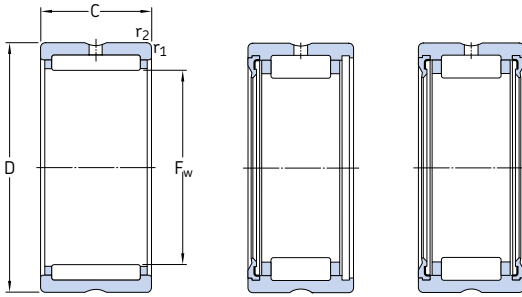

NK(S)
RNA 49
RNA 69

RNA 49 .. RS

RNA 49 ...2RS

F_w	Principal dimensions		Basic load ratings		Fatigue load limit P_u	Speed ratings		Mass	Designation
	D	C	C	C_0		Reference speed	Limiting speed		
mm			kN		kN	r/min		kg	–
18	26	16	12,8	17,6	2,12	22 000	24 000	0,025	NK 18/16
	26	20	16,1	23,6	2,85	22 000	24 000	0,031	NK 18/20
19	27	16	13,4	19	2,28	20 000	24 000	0,026	NK 19/16
	27	20	16,5	25,5	3,05	20 000	24 000	0,032	NK 19/20
20	28	13	11,2	15,3	1,83	19 000	22 000	0,022	RNA 4902
	28	13	9,13	12	1,43	–	9 500	0,02	RNA 4902 RS
	28	13	9,13	12	1,43	–	9 500	0,022	RNA 4902.2RS
	28	16	13,2	19,3	2,28	19 000	22 000	0,027	NK 20/16
	28	20	16,5	25,5	3,05	19 000	22 000	0,034	NK 20/20
	28	23	17,2	27	3,35	19 000	22 000	0,04	RNA 6902
21	29	16	13,8	20,4	2,45	19 000	22 000	0,028	NK 21/16
	29	20	17,2	27	3,35	19 000	22 000	0,035	NK 21/20
22	30	13	11,4	16,3	1,96	18 000	20 000	0,022	RNA 4903
	30	13	9,52	12,9	1,53	–	9 000	0,023	RNA 4903 RS
	30	13	9,52	12,9	1,53	–	9 000	0,023	RNA 4903.2RS
	30	16	14,2	21,6	2,6	18 000	20 000	0,03	NK 22/16
	30	20	17,9	29	3,55	18 000	20 000	0,037	NK 22/20
	30	23	18,7	30,5	3,75	18 000	20 000	0,042	RNA 6903
24	32	16	15,4	24,5	2,9	16 000	19 000	0,032	NK 24/16
	32	20	19	32,5	4	16 000	19 000	0,04	NK 24/20
	37	20	26	33,5	4	15 000	17 000	0,066	NKS 24
25	33	16	15,1	24,5	2,9	16 000	18 000	0,033	NK 25/16
	33	20	19	32,5	4	16 000	18 000	0,042	NK 25/20
	37	17	21,6	28	3,35	15 000	17 000	0,052	RNA 4904
	37	17	19,4	22,4	2,65	–	7 500	0,056	RNA 4904 RS
	37	17	19,4	22,4	2,65	–	7 500	0,056	RNA 4904.2RS
	37	30	35,2	53	6,55	15 000	17 000	0,1	RNA 6904
38	20	27,5	36	4,4	15 000	17 000	0,068	NKS 25	

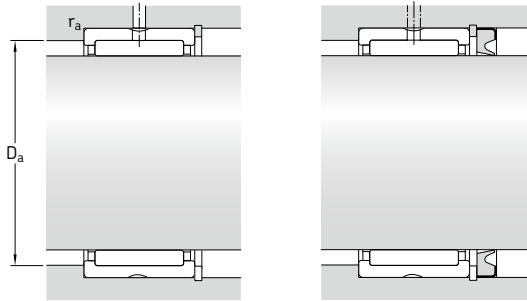

Dimensions		Abutment and fillet dimensions		Appropriate seal ¹⁾ Designation
F _w	r _{1,2} min.	D _a max.	r _a max.	
mm		mm		-
18	0,3	24	0,3	G/SD 18x26x4
	0,3	24	0,3	G/SD 18x26x4
19	0,3	25	0,3	G/SD 19x27x4
	0,3	25	0,3	G/SD 19x27x4
20	0,3	26	0,3	G/SD 20x28x4
	0,3	26	0,3	-
	0,3	26	0,3	-
	0,3	26	0,3	G/SD 20x28x4
	0,3	26	0,3	G/SD 20x28x4
	0,6	28	0,6	CR 20x32x7 HMS5 RG
21	0,3	27	0,3	G 21x29x4
	0,3	27	0,3	G 21x29x4
22	0,3	28	0,3	G/SD 22x30x4
	0,3	28	0,3	-
	0,3	28	0,3	-
	0,3	28	0,3	G/SD 22x30x4
	0,3	28	0,3	G/SD 22x30x4
	0,6	31	0,6	CR 22x35x7 HMS5 RG
24	0,3	30	0,3	G/SD 24x32x4
	0,3	30	0,3	G/SD 24x32x4
	0,6	33	0,6	CR 24x37x7 HMS5 RG
25	0,3	31	0,3	G/SD 25x33x4
	0,3	31	0,3	G/SD 25x33x4
	0,3	35	0,3	CR 25x37x5 HMS5 RG
	0,3	35	0,3	-
	0,3	35	0,3	-
	0,6	35	0,3	CR 25x37x5 HMS5 RG
	0,6	34	0,6	CR 25x38x7 HMS5 RG

¹⁾ For additional information, visit skf.com/seals.

6.3 Needle roller bearings with machined rings with flanges, without an inner ring F_w 26 – 37 mm

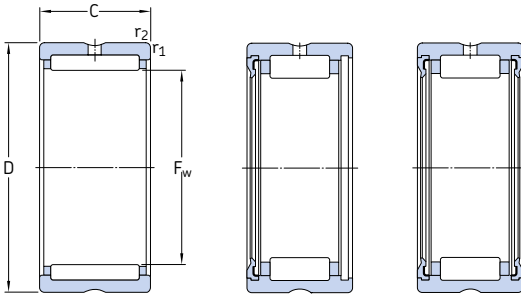

NK(S)
RNA 49
RNA 69

RNA 49 .. RS

RNA 49 ...2RS

Principal dimensions	Basic load ratings		Fatigue load limit	Speed ratings		Mass	Designation		
	dynamic	static		Reference speed	Limiting speed				
F _w	D	C	C	C ₀	P _u				
mm			kN		kN	r/min	kg	–	
26	34	16	15,7	26	3,1	15 000	17 000	0,034	NK 26/16
	34	20	19,4	34,5	4,25	15 000	17 000	0,042	NK 26/20
28	37	20	22	36,5	4,55	14 000	16 000	0,052	NK 28/20
	37	30	31,9	60	7,5	14 000	16 000	0,082	NK 28/30
	39	17	23,3	32	3,9	14 000	15 000	0,05	RNA 49/22
	39	30	36,9	57	7,2	14 000	15 000	0,098	RNA 49/22
	42	20	28,6	39	4,75	13 000	15 000	0,084	NKS 28
29	38	20	24,6	42,5	5,2	14 000	15 000	0,05	NK 29/20 TN
	38	30	31,9	60	7,5	14 000	15 000	0,084	NK 29/30
30	40	20	25,1	44	5,5	13 000	15 000	0,061	NK 30/20 TN
	40	30	36,9	72	9	13 000	15 000	0,092	NK 30/30 TN
	42	17	24,2	34,5	4,15	13 000	15 000	0,061	RNA 4905
	42	17	21,6	27,5	3,25	–	6 300	0,06	RNA 4905 RS
	42	17	21,6	27,5	3,25	–	6 300	0,06	RNA 4905.2RS
	42	30	38	62	7,65	13 000	15 000	0,11	RNA 6905
32	45	22	31,9	43	5,3	12 000	14 000	0,1	NKS 30
	42	20	26,4	48	6	12 000	14 000	0,064	NK 32/20 TN
32	42	30	34,1	65,5	8,3	12 000	14 000	0,1	NK 32/30
	45	17	25,1	36,5	4,4	12 000	14 000	0,073	RNA 4905
	45	30	39,6	65,5	8,3	12 000	14 000	0,14	RNA 69/28
	47	22	34,1	46,5	5,7	12 000	13 000	0,11	NKS 32
	45	20	27,5	52	6,55	11 000	13 000	0,069	NK 35/20 TN
35	45	30	40,2	85	10,6	11 000	13 000	0,11	NK 35/30 TN
	47	17	25,5	39	4,65	11 000	13 000	0,069	RNA 4906
	47	17	23,3	32	3,8	–	5 600	0,069	RNA 4906 RS
	47	17	23,3	32	3,8	–	5 600	0,069	RNA 4906.2RS
	47	30	42,9	75	9,3	11 000	13 000	0,13	RNA 6906
	50	22	35,2	50	6,2	11 000	12 000	0,12	NKS 35
37	47	20	25,1	46,5	5,85	11 000	12 000	0,077	NK 37/20
	47	30	36,9	76,5	9,5	11 000	12 000	0,11	NK 37/30
	52	22	36,9	54	6,55	10 000	12 000	0,12	NKS 37

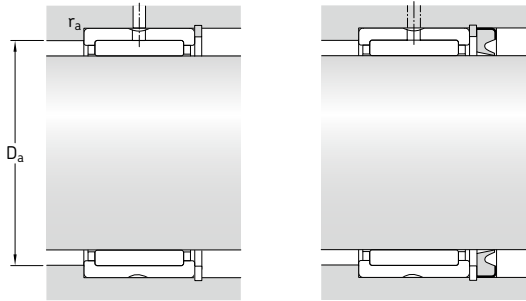

Dimensions		Abutment and fillet dimensions		Appropriate seal ¹⁾ Designation
F _w	r _{1,2} min.	D _a max.	r _a max.	
mm		mm		–
26	0,3	32	0,3	G/SD 26x34x4
	0,3	32	0,3	G/SD 26x34x4
28	0,3	35	0,3	G 28x37x4
	0,3	35	0,3	G 28x37x4
	0,3	37	0,3	–
	0,3	37	0,3	–
	0,6	38	0,6	CR 28x42x7 HMS5 RG
29	0,3	36	0,3	G 29x38x4
	0,3	36	0,3	G 29x38x4
30	0,3	38	0,3	G/SD 30x40x4
	0,3	38	0,3	G/SD 30x40x4
	0,3	40	0,3	CR 30x42x6 HMS5 RG
	0,3	40	0,3	–
	0,3	40	0,3	–
	0,6	40	0,6	CR 30x42x6 HMS5 RG CR 30x45x7 HMS5 RG
32	0,3	40	0,3	G/SD 32x42x4
	0,3	40	0,3	G/SD 32x42x4
	0,3	43	0,3	G 32x45x4
	0,3	43	0,3	G 32x45x4
	0,6	43	0,6	CR 32x47x6 HMS5 RG
35	0,3	43	0,3	G/SD 35x45x4
	0,3	43	0,3	G/SD 35x45x4
	0,3	45	0,3	CR 35x47x6 HMS5 RG
	0,3	45	0,3	–
	0,3	45	0,3	–
	0,6	45	0,6	CR 35x47x6 HMS5 RG CR 35x50x7 HMS5 RG
37	0,3	45	0,3	G/SD 37x47x4
	0,3	45	0,3	G/SD 37x47x4
	0,6	48	0,6	CR 37x52x8 HMS4 R

¹⁾ For additional information, visit skf.com/seals.

6.3 Needle roller bearings with machined rings with flanges, without an inner ring

F_w 38 – 52 mm

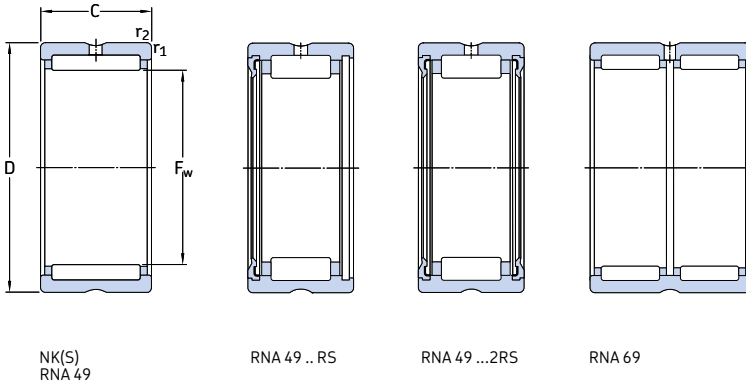

Principal dimensions	Basic load ratings		Fatigue load limit	Speed ratings		Mass	Designation		
	dynamic	static		Reference speed	Limiting speed				
F _w	D	C	C	C ₀	P _u				
mm			kN		kN	r/min	kg	–	
38	48	20	25,5	49	6,1	11 000	12 000	0,079	NK 38/20
	48	30	37,4	80	10	11 000	12 000	0,12	NK 38/30
40	50	20	29,7	60	7,5	10 000	11 000	0,078	NK 40/20 TN
	50	30	38	83	10,4	10 000	11 000	0,13	NK 40/30
	52	20	30,8	51	6,3	10 000	11 000	0,089	RNA 49/32
	52	36	47,3	90	10,8	10 000	11 000	0,16	RNA 49/32
	55	22	38	57	7,1	9 500	11 000	0,13	NKS 40
42	52	20	27	53	6,55	9 500	11 000	0,086	NK 42/20
	52	30	39,1	86,5	10,8	9 500	11 000	0,13	NK 42/30
	55	20	31,9	54	6,7	9 500	11 000	0,11	RNA 4907
	55	20	27	43	5,3	–	4 800	0,11	RNA 4907 RS
	55	20	27	43	5,3	–	4 800	0,11	RNA 4907.2RS
55	36	48,4	93	11,4	9 500	11 000	0,19	RNA 6907	
43	53	20	27,5	55	6,8	9 500	11 000	0,086	NK 43/20
	53	30	40,2	90	11,2	9 500	11 000	0,13	NK 43/30
	58	22	39,1	61	7,5	9 000	10 000	0,14	NKS 43
45	55	20	31,4	65,5	8,3	9 000	10 000	0,085	NK 45/20 TN
	55	30	45,7	108	13,7	9 000	10 000	0,13	NK 45/30 TN
	60	22	40,2	64	8	8 500	10 000	0,15	NKS 45
47	57	20	29,2	61	7,65	8 500	10 000	0,095	NK 47/20
	57	30	41,8	98	12,5	8 500	10 000	0,14	NK 47/30
48	62	22	42,9	71	8,8	8 000	9 500	0,14	RNA 4908
	62	22	36,9	58,5	7,1	–	4 000	0,15	RNA 4908 RS
	62	22	36,9	58,5	7,1	–	4 000	0,15	RNA 4908.2RS
	62	40	67,1	125	15,3	8 000	9 500	0,26	RNA 6908
50	62	25	42,9	91,5	11,2	8 000	9 000	0,15	NK 50/25 TN
	62	35	58,3	137	17	8 000	9 000	0,21	NK 50/35 TN
	65	22	42,9	72	8,8	8 000	9 000	0,16	NKS 50
52	68	22	45,7	78	9,65	7 500	8 500	0,18	RNA 4909
	68	22	39,1	64	7,8	–	3 800	0,16	RNA 4909 RS
	68	22	39,1	64	7,8	–	3 800	0,16	RNA 4909.2RS
	68	40	70,4	137	17	7 500	8 500	0,34	RNA 6909

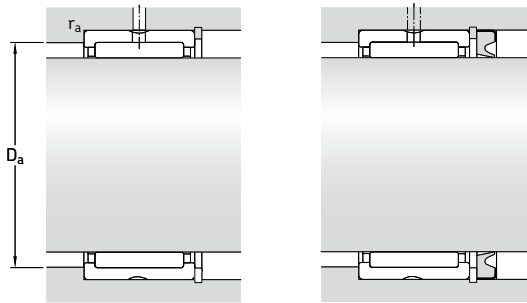

Dimensions		Abutment and fillet dimensions		Appropriate seal ¹⁾ Designation
F _w	r _{1,2} min.	D _a max.	r _a max.	
mm		mm		-
38	0,3	46	0,3	G/SD 38x48x4
	0,3	46	0,3	G/SD 38x48x4
40	0,3	48	0,3	G/SD 40x50x4
	0,3	48	0,3	G/SD 40x50x4
	0,6	48	0,6	G/SD 40x52x5
	0,6	48	0,6	G/SD 40x52x5
	0,6	51	0,6	CR 40x55x7 HMS5 RG
42	0,3	50	0,3	G/SD 42x52x4
	0,3	50	0,3	G/SD 42x52x4
	0,6	51	0,6	CR 42x55x7 HMS5 RG
	0,6	51	0,6	-
	0,6	51	0,6	-
	0,6	51	0,6	CR 42x55x7 HMS5 RG
43	0,3	51	0,3	G 43x53x4
	0,3	51	0,3	G 43x53x4
	0,6	53	0,6	-
45	0,3	53	0,3	G/SD 45x55x4
	0,3	53	0,3	G/SD 45x55x4
	0,6	56	0,6	CR 45x60x7 HMS5 RG
47	0,3	55	0,3	-
	0,3	55	0,3	-
48	0,6	58	0,6	CR 48x62x8 HMS5 RG
	0,6	58	0,6	-
	0,6	58	0,6	-
	0,6	58	0,6	CR 48x62x8 HMS5 RG
50	0,6	58	0,6	G/SD 50x62x5
	0,6	58	0,6	G/SD 50x62x5
	1	60	1	CR 50x65x8 HMS5 RG
52	0,6	64	0,6	CR 52x68x8 HMS5 RG
	0,6	64	0,6	-
	0,6	64	0,6	-
	0,6	64	0,6	CR 52x68x8 HMS5 RG

¹⁾ For additional information, visit skf.com/seals.

6.3 Needle roller bearings with machined rings with flanges, without an inner ring

F_w 55 – 75 mm

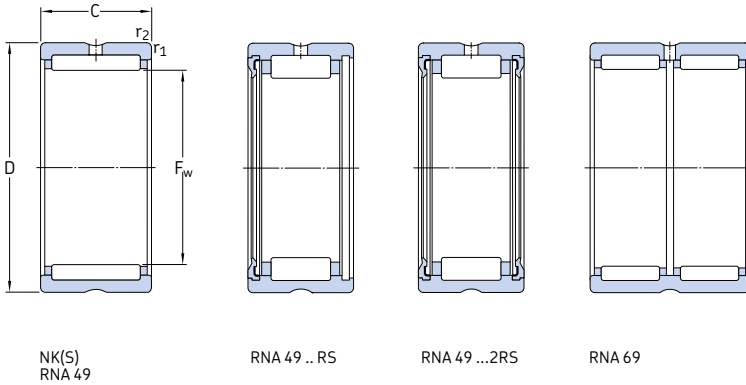

Principal dimensions			Basic load ratings		Fatigue load limit	Speed ratings		Mass	Designation
F_w	D	C	dynamic	static		Reference speed	Limiting speed		
mm			C	C_0	P_u	r/min		kg	–
55	68	25	40,2	88	10,8	7 500	8 500	0,18	NK 55/25
	68	35	52,3	122	15,3	7 500	8 500	0,25	NK 55/35
	72	22	44,6	78	9,8	7 000	8 000	0,22	NKS 55
58	72	22	47,3	85	10,6	7 000	8 000	0,16	RNA 4910
	72	22	40,2	69,5	8,5	–	3 400	0,16	RNA 4910 RS
	72	22	40,2	69,5	8,5	–	3 400	0,16	RNA 4910.2RS
	72	40	73,7	150	18,6	7 000	8 000	0,31	RNA 6910
60	72	25	46,8	110	13,4	6 700	7 500	0,17	NK 60/25 TN
	72	35	55	134	17	6 700	7 500	0,26	NK 60/35
	80	28	62,7	104	13,2	6 300	7 500	0,34	NKS 60
63	80	25	57,2	106	13,2	6 300	7 000	0,26	RNA 4911
	80	45	89,7	190	23,2	6 300	7 000	0,47	RNA 6911
65	78	25	44	104	12,7	6 300	7 000	0,22	NK 65/25
	78	35	58,3	146	18,3	6 300	7 000	0,31	NK 65/35
	85	28	66	114	14,6	6 000	6 700	0,36	NKS 65
68	82	25	44	95	11,8	6 000	6 700	0,24	NK 68/25
	82	35	60,5	146	18,3	6 000	6 700	0,34	NK 68/35
	85	25	60,5	114	14,3	6 000	6 700	0,28	RNA 4912
	85	45	93,5	204	25	6 000	6 700	0,49	RNA 6912
70	85	25	44,6	98	12,2	6 000	6 700	0,26	NK 70/25
	85	35	61,6	150	19	6 000	6 700	0,37	NK 70/35
	90	28	68,2	120	15,3	5 600	6 300	0,38	NKS 70
72	90	25	61,6	120	14,6	5 600	6 300	0,31	RNA 4913
	90	45	95,2	212	26	5 600	6 300	0,58	RNA 6913
73	90	25	52,8	106	13,2	5 600	6 300	0,3	NK 73/25
	90	35	73,7	163	20,4	5 600	6 300	0,43	NK 73/35
75	92	25	53,9	110	13,7	5 300	6 000	0,32	NK 75/25
	92	35	74,8	170	21,2	5 300	6 000	0,45	NK 75/35
	95	28	70,4	132	16,6	5 300	6 000	0,4	NKS 75

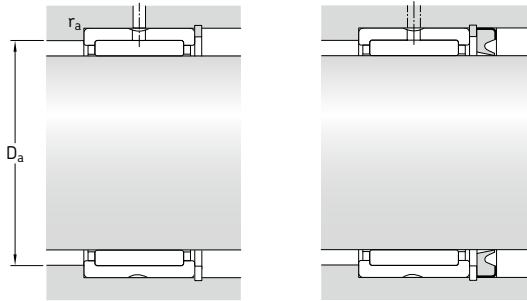

Dimensions		Abutment and fillet dimensions		Appropriate seal ¹⁾ Designation
F _w	r _{1,2} min.	D _a max.	r _a max.	
mm		mm		-
55	0,6	64	0,6	CR 55x68x8 HMS5 RG
	0,6	64	0,6	CR 55x68x8 HMS5 RG
	1	67	1	CR 55x72x8 HMS5 RG
58	0,6	68	0,6	CR 58x72x8 HMS5 RG
	0,6	68	0,6	-
	0,6	68	0,6	-
	0,6	68	0,6	CR 58x72x8 HMS5 RG
60	0,6	68	0,6	CR 60x72x8 HMS5 RG
	0,6	68	0,6	CR 60x72x8 HMS5 RG
	1,1	73,5	1	CR 60x80x8 HMS5 RG
63	1	75	1	CR 63x80x8 CRW1 R
	1	75	1	CR 63x80x8 CRW1 R
65	0,6	74	0,6	-
	0,6	74	0,6	-
	1,1	78,5	1	CR 65x85x8 HMS5 RG
68	0,6	78	0,6	-
	0,6	78	0,6	-
	1	80	1	-
	1	80	1	CR 68x85x8 CRW1 R
70	0,6	81	0,6	CR 70x85x8 HMS5 RG
	0,6	81	0,6	CR 70x85x8 HMS5 RG
	1,1	83,5	1	CR 70x90x10 HMS5 RG
72	1	85	1	CR 72x90x10 HMS5 RG
	1	85	1	CR 72x90x10 HMS5 RG
73	1	85	1	-
	1	85	1	-
75	1	87	1	CR 73x92x11.1 CRWH1 R
	1	87	1	CR 73x92x11.1 CRWH1 R
	1,1	88,5	1	CR 75x95x10 HMS5 RG

¹⁾ For additional information, visit skf.com/seals.

6.3 Needle roller bearings with machined rings with flanges, without an inner ring

F_w 80 – 130 mm

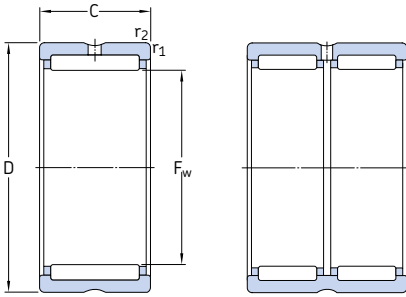

NK
RNA 48
RNA 49

RNA 69

F_w	Principal dimensions		Basic load ratings		Fatigue load limit P_u	Speed ratings		Mass kg	Designation
	D	C	dynamic	static C_0		Reference speed	Limiting speed		
mm	mm	mm	kN	kN	kN	r/min	r/min	kg	–
80	95	25	56,1	127	15,6	5 000	5 600	0,3	NK 80/25
	95	35	76,5	190	24	5 000	5 600	0,43	NK 80/35
	100	30	84,2	163	20,8	5 000	5 600	0,46	RNA 4914
	100	54	128	285	36	5 000	5 600	0,86	RNA 6914
85	105	25	69,3	132	16,6	4 800	5 300	0,43	NK 85/25
	105	30	84,2	170	21,6	4 800	5 300	0,49	RNA 4915
	105	35	96,8	200	26	4 800	5 300	0,6	NK 85/35
	105	54	130	290	37,5	4 800	5 300	0,94	RNA 6915
90	110	25	72,1	140	18	4 500	5 000	0,45	NK 90/25
	110	30	88	183	23,2	4 500	5 000	0,52	RNA 4916
	110	35	101	216	28	4 500	5 000	0,63	NK 90/35
	110	54	134	315	40	4 500	5 000	0,99	RNA 6916
95	115	26	73,7	146	18,6	4 300	4 800	0,49	NK 95/26
	115	36	105	232	30	4 300	4 800	0,68	NK 95/36
100	120	26	76,5	156	19,6	4 000	4 500	0,52	NK 100/26
	120	35	108	250	31	4 000	4 500	0,66	RNA 4917
	120	36	108	250	31	4 000	4 500	0,72	NK 100/36
	120	63	165	425	53	4 000	4 500	1,2	RNA 6917
105	125	26	78,1	166	20,4	3 800	4 300	0,54	NK 105/26
	125	35	112	265	32,5	3 800	4 300	0,75	RNA 4918
	125	36	112	265	32,5	3 800	4 300	0,71	NK 105/36
	125	63	172	450	55	3 800	4 300	1,35	RNA 6918
110	130	30	96,8	220	27	3 600	4 000	0,65	NK 110/30
	130	35	114	270	33,5	3 600	4 000	0,72	RNA 4919
	130	40	123	305	37,5	3 600	4 000	0,83	NK 110/40
	130	63	172	465	56	3 600	4 000	1,45	RNA 6919
115	140	40	125	280	34	3 400	4 000	1,15	RNA 4920
120	140	30	93,5	232	27	3 400	3 800	0,66	RNA 4822
125	150	40	130	300	35,5	3 200	3 600	1,25	RNA 4922
130	150	30	99	255	29	3 200	3 600	0,73	RNA 4824

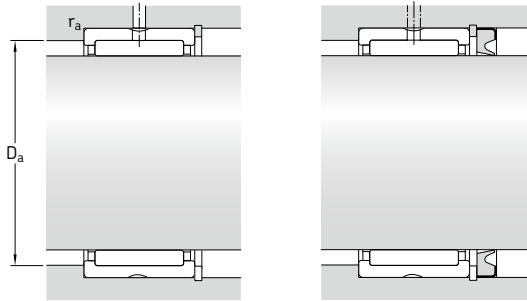

Dimensions		Abutment and fillet dimensions		Appropriate seal ¹⁾ Designation
F _w	r _{1,2} min.	D _a max.	r _a max.	
mm		mm		-
80	1	90	1	CR 80x95x10 HMS5 RG
	1	90	1	CR 80x95x10 HMS5 RG
	1	95	1	CR 80x100x10 HMS5 RG
	1	95	1	CR 80x100x10 HMS5 RG
85	1	100	1	CR 85x105x12 HMS5 RG
	1	100	1	CR 85x105x12 HMS5 RG
	1	100	1	CR 85x105x12 HMS5 RG
	1	100	1	CR 85x105x12 HMS5 RG
90	1	105	1	CR 90x110x10 HMS5 RG
	1	105	1	CR 90x110x10 HMS5 RG
	1	105	1	CR 90x110x10 HMS5 RG
	1	105	1	CR 90x110x10 HMS5 RG
95	1	110	1	CR 95x115x12 HMS5 RG
	1	110	1	CR 95x115x12 HMS5 RG
100	1	115	1	CR 100x120x10 HMS5 RG
	1,1	113,5	1	CR 100x120x10 HMS5 RG
	1	115	1	CR 100x120x10 HMS5 RG
	1,1	113,5	1	CR 100x120x10 HMS5 RG
105	1	120	1	CR 105x125x13 HMS4 R
	1,1	118,5	1	CR 105x125x13 HMS4 R
	1	120	1	CR 105x125x13 HMS4 R
	1,1	118,5	1	CR 105x125x13 HMS4 R
110	1,1	123,5	1	CR 110x130x12 HMS5 RG
	1,1	123,5	1	CR 110x130x12 HMS5 RG
	1,1	123,5	1	CR 110x130x12 HMS5 RG
	1,1	123,5	1	CR 110x130x12 HMS5 RG
115	1,1	133,5	1	CR 115x140x12 HMS5 RG
120	1	135	1	CR 120x140x12 HMS5 RG
125	1,1	143,5	1	CR 125x150x12 HMS5 RG
130	1	145	1	CR 130x150x10 CRSA1 R

¹⁾ For additional information, visit skf.com/seals.

6.3 Needle roller bearings with machined rings with flanges, without an inner ring

F_w 135 – 415 mm

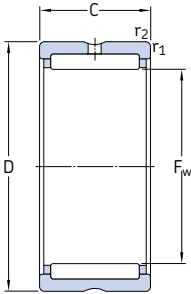

Principal dimensions			Basic load ratings		Fatigue load limit	Speed ratings		Mass	Designation
F_w	D	C	dynamic	static		Reference speed	Limiting speed		
mm	mm	mm	kN	kN	kN	r/min	r/min	kg	–
135	165	45	176	405	46,5	3 000	3 400	1,85	RNA 4924
145	165	35	119	325	36,5	2 800	3 200	0,99	RNA 4826
150	180	50	198	480	54	2 600	3 000	2,2	RNA 4926
155	175	35	121	345	37,5	2 600	3 000	0,97	RNA 4828
160	190	50	205	510	57	2 400	2 800	2,35	RNA 4928
165	190	40	147	415	46,5	2 400	2 800	1,6	RNA 4830
175	200	40	157	450	49	2 200	2 600	1,7	RNA 4832
185	215	45	179	520	56	2 200	2 400	2,55	RNA 4834
195	225	45	190	570	60	2 000	2 400	2,7	RNA 4836
210	240	50	220	710	73,5	1 900	2 200	3,2	RNA 4838
220	250	50	224	735	75	1 800	2 000	3,35	RNA 4840
240	270	50	238	815	81,5	1 700	1 900	3,6	RNA 4844
265	300	60	347	1119,999	110	1 500	1 700	5,4	RNA 4848
285	320	60	358	1199,999	114	1 400	1 500	5,8	RNA 4852
305	350	69	429	1319,999	125	1 300	1 400	9,3	RNA 4856
330	380	80	594	1799,999	166	1 100	1 300	12,5	RNA 4860
350	400	80	605	1899,999	170	1 100	1 200	13,5	RNA 4864
370	420	80	616	1959,999	176	1 000	1 200	14	RNA 4868
390	440	80	627	2039,999	180	950	1 100	15	RNA 4872
415	480	100	968	3 000	260	900	1 000	26	RNA 4876

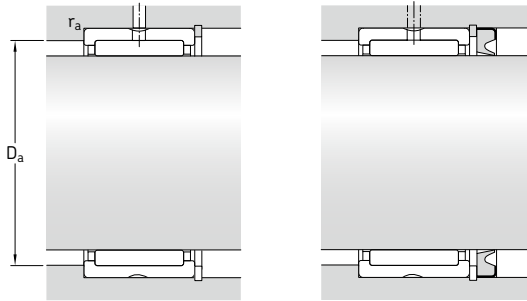

Dimensions		Abutment and fillet dimensions		Appropriate seal ¹⁾ Designation
F _w	r _{1,2} min.	D _a max.	r _a max.	
mm		mm		–
135	1,1	158,5	1	CR 135x165x14 HMSA7 R
145	1,1	158,5	1	–
150	1,5	172	1,5	CR 150x180x12 HMS5 RG
155	1,1	168,5	1	–
160	1,5	182	1,5	CR 160x190x15 HMS5 RG
165	1,1	183,5	1	CR 165x190x15 HMS5 RG
175	1,1	193,5	1	CR 175x200x15 HMS5 RG
185	1,1	208,5	1	CR 185x215x15 HMS42 R
195	1,1	218,5	1	–
210	1,5	232	1,5	CR 210x240x15 HMS5 RG
220	1,5	242	1,5	CR 220x250x15 HMS5 RG
240	1,5	262	1,5	CR 240x270x15 HMS5 RG
265	2	291	2	– ²⁾
285	2	311	2	CR 285x320x16 HDS2 R
305	2	341	2	– ²⁾
330	2,1	369	2	– ²⁾
350	2,1	389	2	–
370	2,1	409	2	–
390	2,1	429	2	– ²⁾
415	2,1	469	2	– ²⁾

¹⁾ For additional information, visit skf.com/seals.

²⁾ Contact SKF for appropriate seal.

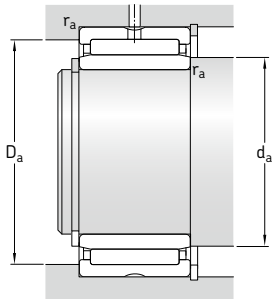
**Dimensions****Abutment and fillet dimensions**

d	F	$r_{1,2}$ min.	$s^{1)}$	d_a min.	D_a max.	r_a max.
mm				mm		
5	8	0,3	1,5	7	13	0,3
	8	0,3	2	7	13	0,3
6	9	0,3	1,5	8	14	0,3
	9	0,3	2	8	14	0,3
7	10	0,3	1,5	9	15	0,3
	10	0,3	2	9	15	0,3
9	12	0,3	1,5	11	17	0,3
	12	0,3	2	11	17	0,3
10	14	0,3	0,5	12	20	0,3
	14	0,3	0,5	12	20	0,3
	14	0,3	0,5	12	20	0,3
	14	0,3	0,5	12	20	0,3
	14	0,3	0,5	12	20	0,3
12	16	0,3	0,5	14	22	0,3
	16	0,3	0,5	14	22	0,3
	16	0,3	0,5	14	22	0,3
	16	0,3	0,5	14	22	0,3
	16	0,3	0,5	14	22	0,3
	16	0,3	1	14	22	0,3
15	19	0,3	0,5	17	25	0,3
	19	0,3	0,5	17	25	0,3
20	20	0,3	0,5	17	26	0,3
	20	0,3	0,5	17	26	0,3
	20	0,3	0,5	17	26	0,3
	20	0,3	1	17	26	0,3
	22	0,6	0,5	19	31	0,6

¹⁾ Permissible axial displacement from the normal position of one bearing ring relative to the other.

6.4 Needle roller bearings with machined rings with flanges, with an inner ring d 17 – 28 mm

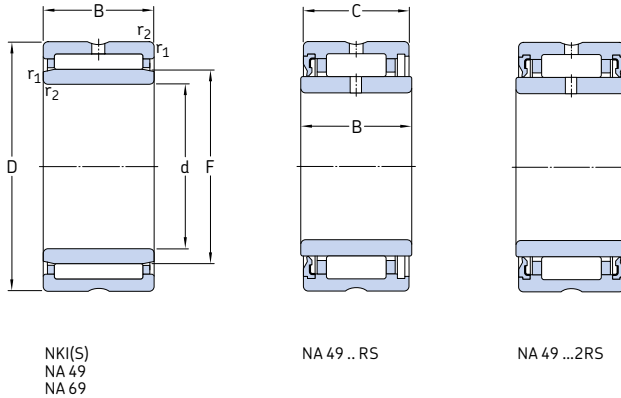

Principal dimensions				Basic load ratings		Fatigue	Speed ratings		Mass	Designation
d	D	B	C	C	C ₀	load limit	Refer-	Limiting		
mm				kN		kN	ence	speed	kg	-
							speed			
17	29	16	-	13,8	20,4	2,45	19 000	22 000	0,042	NKI 17/16
	29	20	-	17,2	27	3,35	19 000	22 000	0,053	NKI 17/20
	30	13	-	11,4	16,3	1,96	18 000	20 000	0,037	NA 4903
	30	14	13	9,52	12,9	1,53	-	9 000	0,04	NA 4903 RS
	30	14	13	9,52	12,9	1,53	-	9 000	0,04	NA 4903.2RS
	30	23	-	18,7	30,5	3,75	18 000	20 000	0,072	NA 6903
	37	20	-	26	33,5	4	15 000	17 000	0,098	NKIS 17
20	32	16	-	15,4	24,5	2,9	16 000	19 000	0,048	NKI 20/16
	32	20	-	19	32,5	4	16 000	19 000	0,06	NKI 20/20
	37	17	-	21,6	28	3,35	15 000	17 000	0,075	NA 4904
	37	18	17	19,4	22,4	2,65	-	7 500	0,08	NA 4904 RS
	37	18	17	19,4	22,4	2,65	-	7 500	0,08	NA 4904.2RS
	37	30	-	35,2	53	6,55	15 000	17 000	0,14	NA 6904
	42	20	-	28,6	39	4,75	13 000	15 000	0,13	NKIS 20
22	34	16	-	15,7	26	3,1	15 000	17 000	0,052	NKI 22/16
	34	20	-	19,4	34,5	4,25	15 000	17 000	0,065	NKI 22/20
	39	17	-	23,3	32	3,9	14 000	15 000	0,08	NA 49/22
	39	30	-	36,9	57	7,2	14 000	15 000	0,15	NA 69/22
25	38	20	-	24,6	42,5	5,2	14 000	15 000	0,08	NKI 25/20 TN
	38	30	-	31,9	60	7,5	14 000	15 000	0,12	NKI 25/30
	42	17	-	24,2	34,5	4,15	13 000	15 000	0,088	NA 4905
	42	18	17	21,6	27,5	3,25	-	6 300	0,09	NA 4905 RS
	42	18	17	21,6	27,5	3,25	-	6 300	0,09	NA 4905.2RS
	42	30	-	38	62	7,65	13 000	15 000	0,16	NA 6905
	47	22	-	34,1	46,5	5,7	12 000	13 000	0,16	NKIS 25
28	42	20	-	26,4	48	6	12 000	14 000	0,092	NKI 28/20 TN
	42	30	-	34,1	65,5	8,3	12 000	14 000	0,14	NKI 28/30
	45	17	-	25,1	36,5	4,4	12 000	14 000	0,098	NA 49/28
	45	30	-	39,6	65,5	8,3	12 000	14 000	0,18	NA 69/28

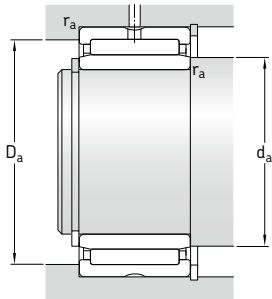

Dimensions

Abutment and fillet dimensions

d	F	$r_{1,2}$ min.	$s^{1)}$	d_a min.	D_a max.	r_a max.
mm						
17	21	0,3	0,5	19	27	0,3
	21	0,3	0,5	19	27	0,3
	22	0,3	0,5	19	28	0,3
	22	0,3	0,5	19	28	0,3
	22	0,3	0,5	19	28	0,3
	22	0,3	1	19	28	0,3
20	24	0,6	0,5	21	33	0,6
	24	0,3	0,5	22	30	0,3
	24	0,3	0,5	22	30	0,3
	25	0,3	0,8	22	35	0,3
	25	0,3	0,5	22	35	0,3
	25	0,3	0,5	22	35	0,3
22	25	0,3	1	22	35	0,3
	28	0,6	0,5	24	38	0,6
	26	0,3	0,5	24	32	0,3
	26	0,3	0,5	24	32	0,3
	28	0,3	0,8	24	37	0,3
	28	0,3	0,5	24	37	0,3
25	29	0,3	1	27	36	0,3
	29	0,3	1,5	27	36	0,3
	30	0,3	0,8	27	40	0,3
	30	0,3	0,5	27	40	0,3
	30	0,3	0,5	27	40	0,3
	30	0,3	1	27	40	0,3
28	32	0,6	1	29	43	0,6
	32	0,3	1	30	40	0,3
	32	0,3	1,5	30	40	0,3
	32	0,3	0,8	30	43	0,3
	32	0,3	1	30	43	0,3
	32	0,3	1	30	43	0,3

¹⁾ Permissible axial displacement from the normal position of one bearing ring relative to the other.

6.4 Needle roller bearings with machined rings with flanges, with an inner ring d 30 – 42 mm

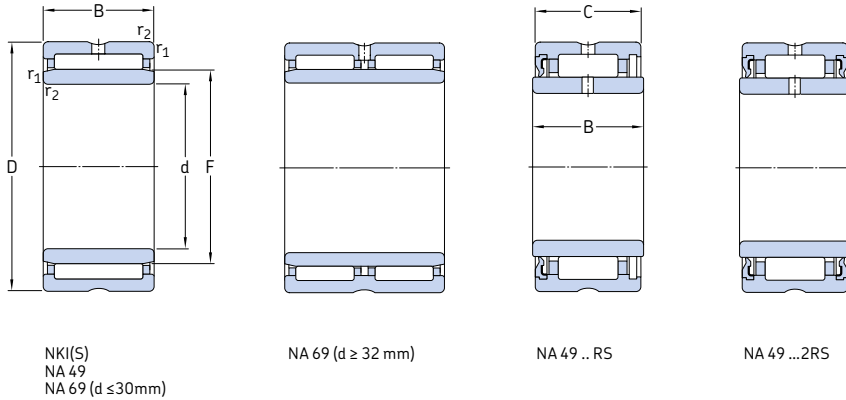

Principal dimensions				Basic load ratings		Fatigue load limit	Speed ratings		Mass	Designation
d	D	B	C	dynamic	static		Reference speed	Limiting speed		
mm	mm	mm	mm	kN	kN	kN	r/min	kg	–	
30	45	20	–	27,5	52	6,55	11 000	13 000	0,11	NKI 30/20 TN
	45	30	–	40,2	85	10,6	11 000	13 000	0,17	NKI 30/30 TN
	47	17	–	25,5	39	4,65	11 000	13 000	0,1	NA 4906
	47	18	17	23,3	32	3,8	–	5 600	0,1	NA 4906 RS
	47	18	17	23,3	32	3,8	–	5 600	0,1	NA 4906.2RS
	47	30	–	42,9	75	9,3	11 000	13 000	0,19	NA 6906
	52	22	–	36,9	54	6,55	10 000	12 000	0,18	NKIS 30
32	47	20	–	25,1	46,5	5,85	11 000	12 000	0,11	NKI 32/20
	47	30	–	36,9	76,5	9,5	11 000	12 000	0,17	NKI 32/30
	52	20	–	30,8	51	6,3	10 000	11 000	0,16	NA 49/32
	52	36	–	47,3	90	10,8	10 000	11 000	0,29	NA 69/32
35	50	20	–	29,7	60	7,5	10 000	11 000	0,12	NKI 35/20 TN
	50	30	–	38	83	10,4	10 000	11 000	0,19	NKI 35/30
	55	20	–	31,9	54	6,7	9 500	11 000	0,17	NA 4907
	55	21	20	27	43	5,3	–	4 800	0,18	NA 4907 RS
	55	21	20	27	43	5,3	–	4 800	0,18	NA 4907.2RS
	55	36	–	48,4	93	11,4	9 500	11 000	0,31	NA 6907
	58	22	–	39,1	61	7,5	9 000	10 000	0,22	NKIS 35
38	53	20	–	27,5	55	6,8	9 500	11 000	0,13	NKI 38/20
	53	30	–	40,2	90	11,2	9 500	11 000	0,21	NKI 38/30
40	55	20	–	31,4	65,5	8,3	9 000	10 000	0,14	NKI 40/20 TN
	55	30	–	45,7	108	13,7	9 000	10 000	0,22	NKI 40/30 TN
	62	22	–	42,9	71	8,8	8 000	9 500	0,23	NA 4908
	62	23	22	36,9	58,5	7,1	–	4 000	0,25	NA 4908 RS
	62	23	22	36,9	58,5	7,1	–	4 000	0,25	NA 4908.2RS
	62	40	–	67,1	125	15,3	8 000	9 500	0,43	NA 6908
42	65	22	–	42,9	72	8,8	8 000	9 000	0,28	NKIS 40
	57	20	–	29,2	61	7,65	8 500	10 000	0,14	NKI 42/20
	57	30	–	41,8	98	12,5	8 500	10 000	0,22	NKI 42/30

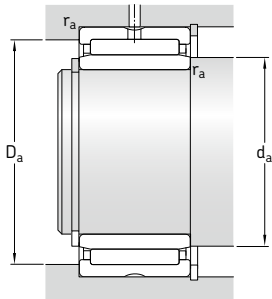

Dimensions

Abutment and fillet dimensions

d	F	$r_{1,2}$ min.	$s^{1)}$	d_a min.	D_a max.	r_a max.
mm						
30	35	0,3	0,5	32	43	0,3
	35	0,3	1	32	43	0,3
30	35	0,3	0,8	32	45	0,3
	35	0,3	0,5	32	45	0,3
	35	0,3	0,5	32	45	0,3
	35	0,3	1	32	45	0,3
	37	0,6	1	34	48	0,6
	32	37	0,3	0,5	34	45
37		0,3	1	34	45	0,3
40		0,6	0,8	36	48	0,6
40		0,6	0,5	36	48	0,6
35	40	0,3	0,5	37	48	0,3
	40	0,3	1	37	48	0,3
35	42	0,6	0,8	39	51	0,6
	42	0,6	0,5	39	51	0,6
	42	0,6	0,5	39	51	0,6
	42	0,6	0,5	39	51	0,6
	43	0,6	0,5	39	53	0,6
38	43	0,3	0,5	40	51	0,3
	43	0,3	1	40	51	0,3
40	45	0,3	0,5	42	53	0,3
	45	0,3	1	42	53	0,3
40	48	0,6	1	44	58	0,6
	48	0,6	0,5	44	58	0,6
	48	0,6	0,5	44	58	0,6
	48	0,6	0,5	44	58	0,6
	50	1	0,5	45	60	1
42	47	0,3	0,5	44	55	0,3
	47	0,3	1	44	55	0,3

¹⁾ Permissible axial displacement from the normal position of one bearing ring relative to the other.

6.4 Needle roller bearings with machined rings with flanges, with an inner ring d 45 – 65 mm

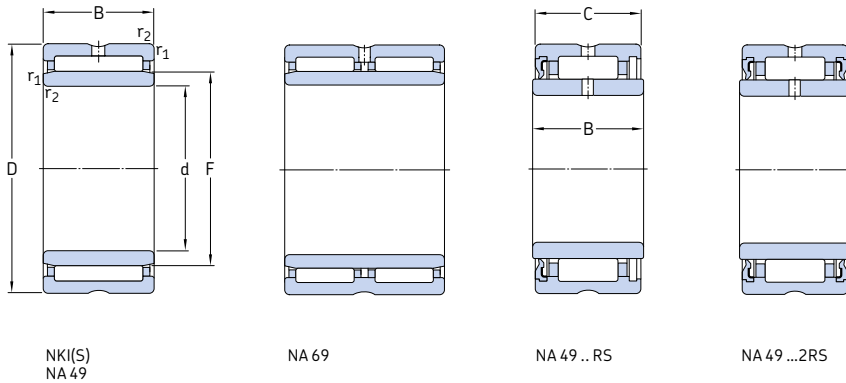

Principal dimensions				Basic load ratings		Fatigue load limit	Speed ratings		Mass	Designation
d	D	B	C	dynamic	static		Reference speed	Limiting speed		
mm	mm	mm	mm	kN	kN	kN	r/min	r/min	kg	–
45	62	25	–	42,9	91,5	11,2	8 000	9 000	0,22	NKI 45/25 TN
	62	35	–	58,3	137	17	8 000	9 000	0,31	NKI 45/35 TN
	68	22	–	45,7	78	9,65	7 500	8 500	0,27	NA 4909
	68	22	22	39,1	64	7,8	–	3 800	0,27	NA 4909 RS
	68	23	22	39,1	64	7,8	–	3 800	0,29	NA 4909.2RS
	68	40	–	70,4	137	17	7 500	8 500	0,5	NA 6909
	72	22	–	44,6	78	9,8	7 000	8 000	0,34	NKIS 45
50	68	25	–	40,2	88	10,8	7 500	8 500	0,26	NKI 50/25
	68	35	–	52,3	122	15,3	7 500	8 500	0,36	NKI 50/35
	72	22	–	47,3	85	10,6	7 000	8 000	0,27	NA 4910
	72	23	22	40,2	69,5	8,5	–	3 400	0,3	NA 4910 RS
	72	23	22	40,2	69,5	8,5	–	3 400	0,3	NA 4910.2RS
	72	40	–	73,7	150	18,6	7 000	8 000	0,52	NA 6910
	80	28	–	62,7	104	13,2	6 300	7 500	0,52	NKIS 50
	55	72	25	–	46,8	110	13,4	6 700	7 500	0,26
72		35	–	55	134	17	6 700	7 500	0,36	NKI 55/35
80		25	–	57,2	106	13,2	6 300	7 000	0,39	NA 4911
80		45	–	89,7	190	23,2	6 300	7 000	0,78	NA 6911
85		28	–	66	114	14,6	6 000	6 700	0,56	NKIS 55
60		82	25	–	44	95	11,8	6 000	6 700	0,39
	82	35	–	60,5	146	18,3	6 000	6 700	0,55	NKI 60/35
	85	25	–	60,5	114	14,3	6 000	6 700	0,43	NA 4912
	85	45	–	93,5	204	25	6 000	6 700	0,81	NA 6912
	90	28	–	68,2	120	15,3	5 600	6 300	0,56	NKIS 60
65	90	25	–	61,6	120	14,6	5 600	6 300	0,46	NA 4913
	90	25	–	52,8	106	13,2	5 600	6 300	0,46	NKI 65/25
	90	35	–	73,7	163	20,4	5 600	6 300	0,66	NKI 65/35
	90	45	–	95,2	212	26	5 600	6 300	0,83	NA 6913
	95	28	–	70,4	132	16,6	5 300	6 000	0,64	NKIS 65

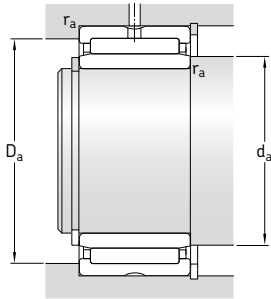

Dimensions

Abutment and fillet dimensions

d	F	r _{1,2} min.	s ¹⁾	d _a min.	D _a max.	r _a max.
mm						
45	50	0,6	1,5	49	58	0,6
	50	0,6	2	49	58	0,6
	52	0,6	1	49	64	0,6
	52	0,6	0,5	49	64	0,6
	52	0,6	0,5	49	64	0,6
	52	0,6	0,5	49	64	0,6
50	55	1	0,5	50	67	1
	55	0,6	1,5	54	64	0,6
		0,6	2	54	64	0,6
	58	0,6	1	54	68	0,6
	58	0,6	0,5	54	68	0,6
	58	0,6	0,5	54	68	0,6
60	1,1	2	56,5	73,5	1	
55	60	0,6	1,5	59	68	0,6
	60	0,6	2	59	68	0,6
	63	1	1,5	60	75	1
	63	1	1,5	60	75	1
	65	1,1	2	61,5	78,5	1
60	68	0,6	1	64	78	0,6
	68	0,6	1	64	78	0,6
	68	1	1,5	65	80	1
	68	1	1,5	65	80	1
	70	1,1	2	66,5	83,5	1
65	72	1	1,5	70	85	1
	73	1	1	70	85	1
	73	1	1	70	85	1
	72	1	1,5	70	85	1
	75	1,1	2	71,5	88,5	1

¹⁾ Permissible axial displacement from the normal position of one bearing ring relative to the other.

6.4 Needle roller bearings with machined rings with flanges, with an inner ring d 70 – 110 mm

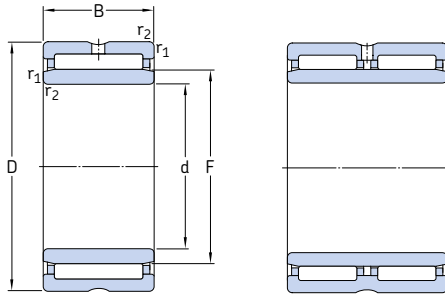

NKI(S)
NA 48
NA 49

NA 69

Principal dimensions			Basic load ratings		Fatigue load limit	Speed ratings		Mass	Designation
d	D	B	dynamic	static		Reference speed	Limiting speed		
mm			kN	C ₀	P _u	r/min		kg	–
70	95	25	56,1	127	15,6	5 000	5 600	0,51	NKI 70/25
	95	35	76,5	190	24	5 000	5 600	0,72	NKI 70/35
	100	30	84,2	163	20,8	5 000	5 600	0,73	NA 4914
	100	54	128	285	36	5 000	5 600	1,35	NA 6914
75	105	25	69,3	132	16,6	4 800	5 300	0,64	NKI 75/25
	105	30	84,2	170	21,6	4 800	5 300	0,78	NA 4915
	105	35	96,8	200	26	4 800	5 300	0,91	NKI 75/35
	105	54	130	290	37,5	4 800	5 300	1,45	NA 6915
80	110	25	72,1	140	18	4 500	5 000	0,68	NKI 80/25
	110	30	88	183	23,2	4 500	5 000	0,88	NA 4916
	110	35	101	216	28	4 500	5 000	0,96	NKI 80/35
	110	54	134	315	40	4 500	5 000	1,5	NA 6916
85	115	26	73,7	146	18,6	4 300	4 800	0,74	NKI 85/26
	115	36	105	232	30	4 300	4 800	1,05	NKI 85/36
	120	35	108	250	31	4 000	4 500	1,25	NA 4917
	120	63	165	425	53	4 000	4 500	2,2	NA 6917
90	120	26	76,5	156	19,6	4 000	4 500	0,78	NKI 90/26
	120	36	108	250	31	4 000	4 500	1,1	NKI 90/36
	125	35	112	265	32,5	3 800	4 300	1,3	NA 4918
	125	63	172	450	55	3 800	4 300	2,3	NA 6918
95	125	26	78,1	166	20,4	3 800	4 300	0,82	NKI 95/26
	125	36	112	265	32,5	3 800	4 300	1,15	NKI 95/36
	130	35	114	270	33,5	3 600	4 000	1,35	NA 4919
	130	63	172	465	56	3 600	4 000	2,5	NA 6919
100	130	30	96,8	220	27	3 600	4 000	0,99	NKI 100/30
	130	40	123	305	37,5	3 600	4 000	1,35	NKI 100/40
	140	40	125	280	34	3 400	4 000	1,9	NA 4920
110	140	30	93,5	232	27	3 400	3 800	1,1	NA 4822
	150	40	130	300	35,5	3 200	3 600	2,05	NA 4922

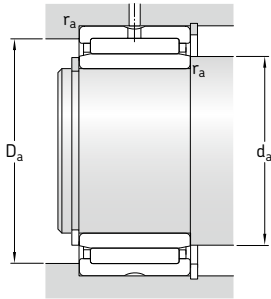

Dimensions

Abutment and fillet dimensions

d	F	$r_{1,2}$ min.	$s^{1)}$	d_a min.	D_a max.	r_a max.
mm						
70	80	1	0,8	75	90	1
	80	1	0,8	75	90	1
	80	1	1,5	75	95	1
	80	1	1	75	95	1
75	85	1	1	80	100	1
	85	1	1,5	80	100	1
	85	1	1	80	100	1
	85	1	1	80	100	1
80	90	1	1	85	105	1
	90	1	1,5	85	105	1
	90	1	1	85	105	1
	90	1	1	85	105	1
85	95	1	1,5	90	110	1
	95	1	1,5	90	110	1
	100	1,1	1	91,5	113,5	1
	100	1,1	1	91,5	113,5	1
90	100	1	1,5	95	115	1
	100	1	1,5	95	115	1
	105	1,1	1	96,5	118,5	1
	105	1,1	1	96,5	118,5	1
95	105	1	1,5	100	120	1
	105	1	1,5	100	120	1
	110	1,1	1	101,5	123,5	1
	110	1,1	1	101,5	123,5	1
100	110	1,1	1,5	106,5	123,5	1
	110	1,1	2	106,5	123,5	1
	115	1,1	2	106,5	133,5	1
110	120	1	0,8	115	135	1
	125	1,1	2	116,5	143,5	1

¹⁾ Permissible axial displacement from the normal position of one bearing ring relative to the other.

6.4 Needle roller bearings with machined rings with flanges, with an inner ring d 120 – 380 mm

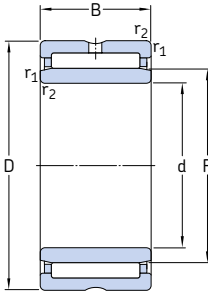

Principal dimensions			Basic load ratings		Fatigue load limit	Speed ratings		Mass	Designation
d	D	B	dynamic	static		Reference speed	Limiting speed		
mm			C	C ₀	P _u	r/min		kg	–
120	150	30	99	255	29	3 200	3 600	1,15	NA 4824
	165	45	176	405	46,5	3 000	3 400	2,85	NA 4924
130	165	35	119	325	36,5	2 800	3 200	1,8	NA 4826
	180	50	198	480	54	2 600	3 000	3,9	NA 4926
140	175	35	121	345	37,5	2 600	3 000	1,9	NA 4828
	190	50	205	510	57	2 400	2 800	4,15	NA 4928
150	190	40	147	415	46,5	2 400	2 800	2,7	NA 4830
160	200	40	157	450	49	2 200	2 600	2,85	NA 4832
170	215	45	179	520	56	2 200	2 400	3,95	NA 4834
180	225	45	190	570	60	2 000	2 400	4,2	NA 4836
190	240	50	220	710	73,5	1 900	2 200	5,55	NA 4838
200	250	50	224	735	75	1 800	2 000	5,8	NA 4840
220	270	50	238	815	81,5	1 700	1 900	6,35	NA 4844
240	300	60	347	1 120	110	1 500	1 700	9,9	NA 4848
260	320	60	358	1 200	114	1 400	1 500	10,5	NA 4852
280	350	69	429	1 320	125	1 300	1 400	15,5	NA 4856
300	380	80	594	1 800	166	1 100	1 300	22	NA 4860
320	400	80	605	1 900	170	1 100	1 200	23	NA 4864
340	420	80	616	1 960	176	1 000	1 200	24	NA 4868
360	440	80	627	2 040	180	950	1 100	25,5	NA 4872
380	480	100	968	3 000	260	900	1 000	42,5	NA 4876

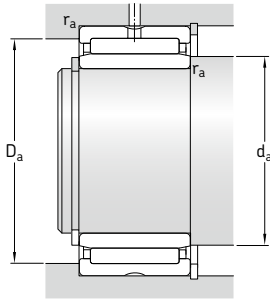
**Dimensions****Abutment and fillet dimensions**

d	F	$r_{1,2}$ min.	$s^{1)}$	d_a min.	D_a max.	r_a max.
mm				mm		
120	130	1	0,8	125	145	1
	135	1,1	2	126,5	158,5	1
130	145	1,1	1	136,5	158,5	1
	150	1,5	1,5	138	172	1,5
140	155	1,1	1	146,5	168,5	1
	160	1,5	1,5	148	182	1,5
150	165	1,1	1,5	156,5	183,5	1
160	175	1,1	1,5	166,5	193,5	1
170	185	1,1	1,5	176,5	208,5	1
180	195	1,1	1,5	186,5	218,5	1
190	210	1,5	1,5	198	232	1,5
200	220	1,5	1,5	208	242	1,5
220	240	1,5	1,5	228	262	1,5
240	265	2	2	249	291	2
260	285	2	2	269	311	2
280	305	2	2,5	289	341	2
300	330	2,1	2	311	369	2
320	350	2,1	2	331	389	2
340	370	2,1	2	351	409	2
360	390	2,1	2	371	429	2
380	415	2,1	2	391	469	2

¹⁾ Permissible axial displacement from the normal position of one bearing ring relative to the other.

6.5 Needle roller bearings with machined rings without flanges, without an inner ring

F_w 5 – 30 mm

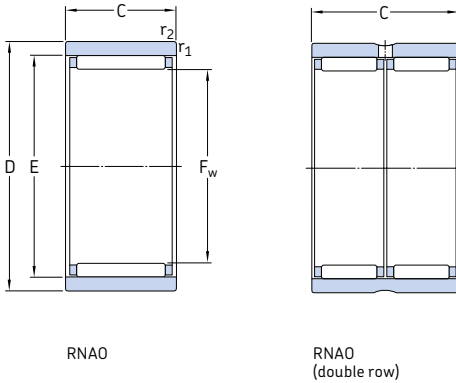

F_w	Principal dimensions		Basic load ratings		Fatigue load limit P_u	Speed ratings		Mass	Designation
	D	C	C	C_0		Reference speed	Limiting speed		
mm			kN		kN	r/min	kg	–	
5	10	8	2,29	2	0,212	36 000	40 000	0,003	RNAO 5x10x8 TN
6	13	8	2,55	2,36	0,25	34 000	38 000	0,006	RNAO 6x13x8 TN
7	14	8	2,81	2,75	0,29	32 000	36 000	0,006	RNAO 7x14x8 TN
8	15	10	3,8	4,25	0,465	32 000	36 000	0,008	RNAO 8x15x10 TN
10	17	10	4,57	5,7	0,63	28 000	32 000	0,01	RNAO 10x17x10 TN
12	22	12	9,52	10	1,18	26 000	30 000	0,019	RNAO 12x22x12 TN
15	23	13	8,25	11,2	1,29	24 000	28 000	0,02	RNAO 15x23x13
16	24	13	8,58	12	1,37	24 000	26 000	0,021	RNAO 16x24x13
	28	12	11	12,5	1,5	22 000	26 000	0,032	RNAO 16x28x12
17	25	13	10,1	14,6	1,73	22 000	26 000	0,022	RNAO 17x25x13
18	30	24	20,9	30	3,6	20 000	24 000	0,069	RNAO 18x30x24 ¹⁾
20	28	13	9,52	14,6	1,66	20 000	22 000	0,025	RNAO 20x28x13
	28	26	16,1	29	3,35	20 000	22 000	0,05	RNAO 20x28x26 ¹⁾
	32	12	12,8	16,3	1,96	19 000	22 000	0,038	RNAO 20x32x12
22	30	13	10,1	16,3	1,86	18 000	20 000	0,027	RNAO 22x30x13
	35	16	19,4	25,5	3,05	17 000	19 000	0,059	RNAO 22x35x16
25	35	17	14,2	26,5	3,1	16 000	18 000	0,053	RNAO 25x35x17
	35	26	18,7	37,5	4,3	16 000	18 000	0,076	RNAO 25x35x26 ¹⁾
	37	16	20,1	28	3,35	15 000	17 000	0,06	RNAO 25x37x16
30	40	17	18,7	34	4,05	13 000	15 000	0,06	RNAO 30x40x17
	42	16	22	33,5	4	13 000	15 000	0,059	RNAO 30x42x16
	42	32	38	67	8	13 000	15 000	0,14	RNAO 30x42x32 ¹⁾

¹⁾ Double row, outer ring with a lubrication hole and an annular groove.

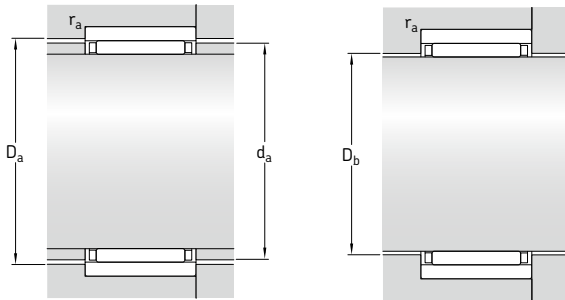

Dimensions

Abutment and fillet dimensions

F_w	E	$r_{1,2}$ min.	d_a	D_a	D_b	r_a max.
mm		mm				
5	8	0,15	7,7	8,3	5,3	0,1
6	9	0,3	8,7	9,3	6,3	0,3
7	10	0,3	9,7	10,3	7,3	0,3
8	11	0,3	10,7	11,3	8,3	0,3
10	13	0,3	12,7	13,3	10,3	0,3
12	18	0,3	17,6	18,3	12,3	0,3
15	19	0,3	18,6	19,3	15,4	0,3
16	20	0,3	19,6	20,3	16,4	0,3
	22	0,3	21,6	22,3	16,4	0,3
17	21	0,3	20,6	21,3	17,4	0,3
18	24	0,3	23,6	24,5	18,4	0,3
20	24	0,3	23,6	24,3	20,4	0,3
	24	0,3	23,6	24,3	20,4	0,3
	26	0,3	25,6	26,5	20,4	0,3
22	26	0,3	25,6	26,3	22,4	0,3
	29	0,3	28,4	29,5	22,4	0,3
25	29	0,3	28,4	29,5	25,6	0,3
	29	0,3	28,4	29,5	25,6	0,3
	32	0,3	31,4	32,5	25,6	0,3
30	35	0,3	34,4	35,5	30,6	0,3
	37	0,3	36,4	37,5	30,6	0,3
	37	0,3	36,4	37,5	30,6	0,3

6.5 Needle roller bearings with machined rings without flanges, without an inner ring F_w 35 – 100 mm

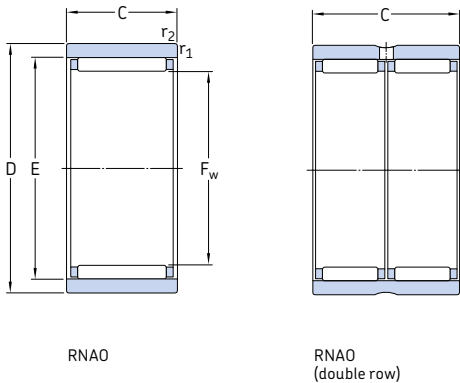

Principal dimensions	Basic load ratings		Fatigue load limit	Speed ratings		Mass	Designation		
	dynamic	static		Reference speed	Limiting speed				
F _w	D	C	C	C ₀	P _u				
mm			kN		kN	r/min	kg	–	
35	45	13	15,4	28	3,25	12 000	13 000	0,059	RNAO 35x45x13
	45	17	19,8	39	4,65	12 000	13 000	0,069	RNAO 35x45x17
	45	26	26,4	56	6,55	12 000	13 000	0,091	RNAO 35x45x26 ¹⁾
	47	16	23,3	37,5	4,5	11 000	13 000	0,078	RNAO 35x47x16
	47	18	26,4	44	5,3	11 000	13 000	0,076	RNAO 35x47x18
	47	32	40,2	75	9	11 000	13 000	0,16	RNAO 35x47x32 ¹⁾
40	50	17	20,5	41,5	5	10 000	12 000	0,074	RNAO 40x50x17
	50	34	35,2	83	10	10 000	12 000	0,15	RNAO 40x50x34 ¹⁾
	55	20	31,4	57	6,95	10 000	11 000	0,15	RNAO 40x55x20
	55	40	59,4	118	14,6	10 000	11 000	0,28	RNAO 40x55x40 ¹⁾
45	55	17	21,6	46,5	5,6	9 000	10 000	0,083	RNAO 45x55x17
	62	40	64,4	137	16,6	9 000	10 000	0,38	RNAO 45x62x40 ¹⁾
50	62	20	25,5	60	7,2	8 500	9 500	0,14	RNAO 50x62x20
	65	20	34,1	62	7,65	8 000	9 000	0,17	RNAO 50x65x20
	65	40	58,3	125	15,3	8 000	9 000	0,36	RNAO 50x65x40 ¹⁾
55	68	20	27	67	8,15	7 500	8 500	0,17	RNAO 55x68x20
60	78	20	41,8	86,5	10,6	6 700	7 500	0,26	RNAO 60x78x20
	78	40	72,1	173	21,2	6 700	7 500	0,44	RNAO 60x78x40 ¹⁾
65	85	30	53,9	125	15,6	6 300	7 000	0,46	RNAO 65x85x30
70	90	30	57,2	137	17	6 000	6 700	0,5	RNAO 70x90x30
80	100	30	68,2	176	22	5 000	6 000	0,58	RNAO 80x100x30
90	105	26	58,3	150	18,6	4 500	5 300	0,37	RNAO 90x105x26
	110	30	64,4	173	21,6	4 500	5 300	0,61	RNAO 90x110x30
100	120	30	67,1	190	23,6	4 000	4 800	0,69	RNAO 100x120x30

¹⁾ Double row, outer ring with a lubrication hole and an annular groove.

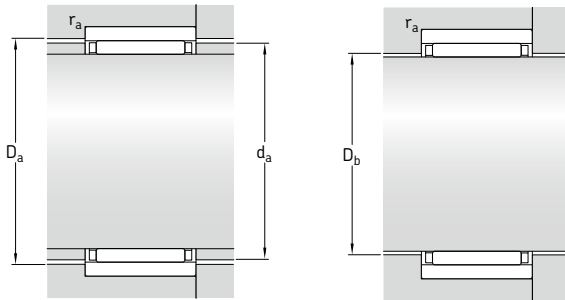

Dimensions

Abutment and fillet dimensions

F_w	E	$r_{1,2}$ min.	d_a	D_a	D_b	r_a max.
mm		mm				
35	40	0,3	39,4	40,5	35,6	0,3
	40	0,3	39,4	40,5	35,6	0,3
	40	0,3	39,4	40,5	35,6	0,3
	42	0,3	41,4	42,5	35,6	0,3
	42	0,3	41,4	42,5	35,6	0,3
	42	0,3	41,4	42,5	35,6	0,3
40	45	0,3	44,4	45,5	40,6	0,3
	45	0,3	44,4	45,5	40,6	0,3
	47	0,3	46,2	47,5	40,6	0,3
	48	0,3	47,2	47,5	40,6	0,3
45	50	0,3	49,2	50,5	45,6	0,3
	53	0,3	52,2	53,5	45,6	0,3
50	55	0,3	54,2	55,8	50,6	0,3
	58	0,3	57,2	58,5	50,6	0,3
	58	0,6	57,2	58,5	50,6	0,6
55	60	0,6	59,2	60,8	55,8	0,6
60	68	1	67,2	68,8	60,8	1
	68	1	67,2	68,8	60,8	1
65	73	1	72,2	73,8	66	1
70	78	1	77,2	78,8	71	1
80	88	1	87,2	89	81	1
90	98	1	97,2	99	91	1
	98	1	97,2	99	91	1
100	108	1	107,2	109	101	1

6.6 Needle roller bearings with machined rings without flanges, with an inner ring d 6 – 90 mm

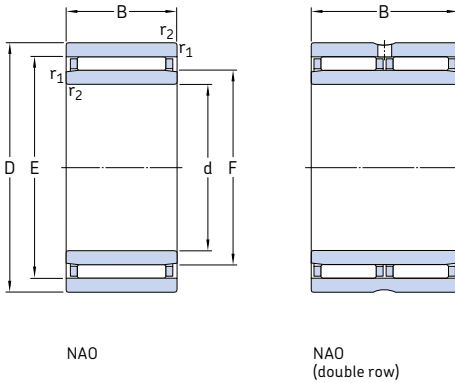

Principal dimensions			Basic load ratings		Fatigue load limit	Speed ratings		Mass	Designation
d	D	B	dynamic	static		Reference speed	Limiting speed		
mm			C	C ₀	P _u	r/min		kg	–
6	17	10	4,57	5,7	0,63	28 000	32 000	0,014	NAO 6x17x10 TN ¹⁾
9	22	12	9,52	10	1,18	26 000	30 000	0,024	NAO 9x22x12 TN
12	24	13	8,58	12	1,37	24 000	26 000	0,03	NAO 12x24x13
	28	12	11	12,5	1,5	22 000	26 000	0,04	NAO 12x28x12 ¹⁾
15	28	13	9,52	14,6	1,66	20 000	22 000	0,029	NAO 15x28x13
	32	12	12,8	16,3	1,96	19 000	22 000	0,047	NAO 15x32x12 ¹⁾
17	30	13	10,1	16,3	1,86	18 000	20 000	0,042	NAO 17x30x13
	35	16	19,4	25,5	3,05	17 000	19 000	0,078	NAO 17x35x16
20	35	17	14,2	26,5	3,1	16 000	18 000	0,076	NAO 20x35x17
	37	16	20,1	28	3,35	15 000	17 000	0,082	NAO 20x37x16
25	40	17	18,7	34	4,05	13 000	15 000	0,088	NAO 25x40x17
	42	16	22	33,5	4	13 000	15 000	0,086	NAO 25x42x16 ¹⁾
	42	32	38	67	8	13 000	15 000	0,17	NAO 25x42x32 ²⁾
30	45	17	19,8	39	4,65	12 000	13 000	0,1	NAO 30x45x17
	45	26	26,4	56	6,55	12 000	13 000	0,16	NAO 30x45x26 ²⁾
	47	16	23,3	37,5	4,5	11 000	13 000	0,11	NAO 30x47x16
	47	18	26,4	44	5,3	11 000	13 000	0,12	NAO 30x47x18
35	50	17	20,5	41,5	5	10 000	12 000	0,11	NAO 35x50x17
	55	20	31,4	57	6,95	10 000	11 000	0,19	NAO 35x55x20
40	55	17	21,6	46,5	5,6	9 000	10 000	0,13	NAO 40x55x17
50	68	20	27	67	8,15	7 500	8 500	0,23	NAO 50x68x20 ¹⁾
70	100	30	68,2	176	22	5 000	6 000	0,85	NAO 70x100x30
80	110	30	64,4	173	21,6	4 500	5 300	0,92	NAO 80x110x30
90	120	30	67,1	190	23,6	4 000	4 800	1,05	NAO 90x120x30

¹⁾ One lubrication hole in the inner ring.

²⁾ Double row, outer ring with a lubrication hole and an annular groove.

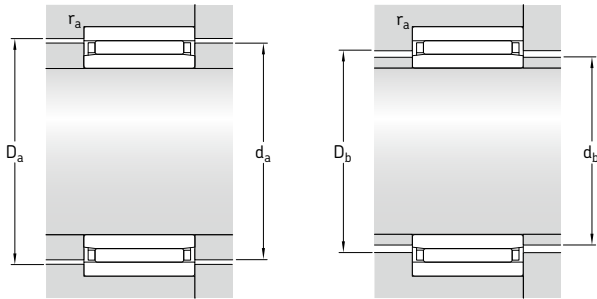

Dimensions

Abutment and fillet dimensions

d	E	F	$r_{1,2}$ min.	$s^{1)}$	d_a	d_b	D_a	D_b	r_a max.
mm					mm				
6	13	10	0,3	0,5	12,7	9,7	13,3	10,3	0,3
9	18	12	0,3	0,5	17,6	11,7	18,3	12,3	0,3
12	20	16	0,3	0,5	19,6	15,7	20,3	16,4	0,3
	22	16	0,3	0,5	21,6	15,7	22,3	16,4	0,3
15	24	20	0,3	0,5	23,6	19,7	24,3	20,4	0,3
	26	20	0,3	0,5	25,6	19,7	26,5	20,4	0,3
17	26	22	0,3	0,5	25,6	21,5	26,3	22,4	0,3
	29	22	0,3	0,5	28,4	21,5	29,5	22,4	0,3
20	29	25	0,3	0,5	28,4	24,5	29,5	25,6	0,3
	32	25	0,3	0,5	31,4	24,5	32,5	25,6	0,3
25	35	30	0,3	0,8	34,4	29,5	35,5	30,6	0,3
	37	30	0,3	0,8	36,4	29,5	37,5	30,6	0,3
	37	30	0,3	0,8	36,4	29,5	37,5	30,6	0,3
30	40	35	0,3	0,8	39,4	34,5	40,5	35,6	0,3
	40	35	0,3	0,8	39,4	34,5	40,5	35,6	0,3
	42	35	0,3	0,8	41,4	34,5	42,5	35,6	0,3
	42	35	0,3	0,8	41,4	34,5	42,5	35,6	0,3
35	45	40	0,3	0,8	44,4	39,5	45,5	40,6	0,3
	47	40	0,3	0,8	46,2	39,5	47,5	40,6	0,3
40	50	45	0,3	0,8	49,2	44,5	50,5	45,6	0,3
50	60	55	0,6	1	59,2	54,5	60,8	55,8	0,6
70	88	80	1	1	87,2	79,3	89	81	1
80	98	90	1	1	97,2	89,3	99	91	1
90	108	100	1	1	107,2	99,3	109	101	1

¹⁾ Permissible axial displacement from the normal position of one bearing ring relative to the other.

6.7 Alignment needle roller bearings, without an inner ring

F_w 15 – 45 mm

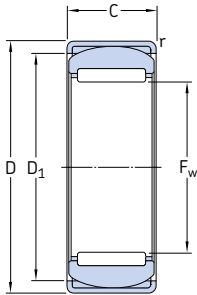

Principal dimensions			Basic load ratings		Fatigue load limit P_u	Speed ratings		Mass kg	Designation
F_w	D	C	dynamic C	static C_0		Reference speed	Limiting speed		
mm			kN		kN	r/min			–
15	28	12	7,37	9,15	1,08	24 000	28 000	0,032	RPNA 15/28
18	32	16	12,8	17,6	2,12	22 000	24 000	0,052	RPNA 18/32
20	35	16	13,2	19,3	2,28	19 000	22 000	0,062	RPNA 20/35
25	42	20	19	32,5	4	16 000	18 000	0,11	RPNA 25/42
28	44	20	22	36,5	4,55	14 000	16 000	0,11	RPNA 28/44
30	47	20	22,9	38	4,8	13 000	15 000	0,13	RPNA 30/47
35	52	20	24,6	45	5,6	11 000	13 000	0,13	RPNA 35/52
40	55	20	26,4	51	6,3	10 000	11 000	0,14	RPNA 40/55
45	62	20	27,5	57	7,1	9 000	10 000	0,18	RPNA 45/62

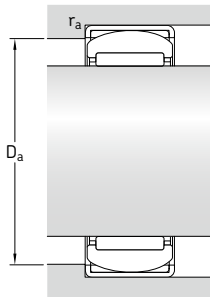

Dimensions

Abutment and fillet dimensions

F_w	D_1	$r_{\min.}$	$D_{a\min.}$	$D_{a\max.}$	$r_{a\max.}$
mm			mm		
15	24,5	0,8	23,5	24,5	0,8
18	27	0,8	26	27	0,8
20	30,5	0,8	29,5	30,5	0,8
25	36,5	0,8	35	37	0,8
28	38,5	0,8	37,5	39	0,8
30	42	0,8	41	42	0,8
35	47,5	0,8	46,5	47,5	0,8
40	50,5	0,8	49,5	50,5	0,8
45	58	0,8	57	58	0,8

6.8 Alignment needle roller bearings with an inner ring d 12 – 40 mm

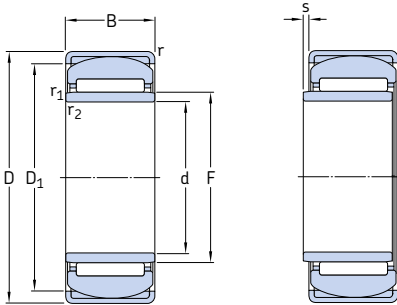

Principal dimensions			Basic load ratings dynamic static		Fatigue load limit	Speed ratings Reference speed Limiting speed		Mass	Designation
d	D	B	C	C ₀	P _u			kg	–
mm			kN		kN	r/min			
12	28	12	7,37	9,15	1,08	24 000	28 000	0,037	PNA 12/28
15	32	16	12,8	17,6	2,12	22 000	24 000	0,062	PNA 15/32
17	35	16	13,2	19,3	2,28	19 000	22 000	0,073	PNA 17/35
20	42	20	19	32,5	4	16 000	18 000	0,14	PNA 20/42
22	44	20	22	36,5	4,55	14 000	16 000	0,15	PNA 22/44
25	47	20	22,9	38	4,8	13 000	15 000	0,16	PNA 25/47
30	52	20	24,6	45	5,6	11 000	13 000	0,18	PNA 30/52
35	55	20	26,4	51	6,3	10 000	11 000	0,18	PNA 35/55
40	62	20	27,5	57	7,1	9 000	10 000	0,23	PNA 40/62

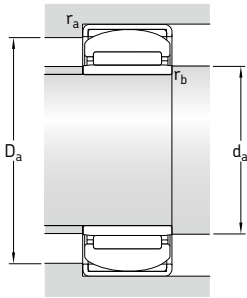

Dimensions

Abutment and fillet dimensions

d	F	D ₁	r min.	r _{1,2} min.	s ¹⁾	d _a min.	D _a min.	D _a max.	r _a max.	r _b max.
mm						mm				
12	15	24,5	0,8	0,3	0,5	14	23,5	24,5	0,8	0,3
15	18	27	0,8	0,3	0,5	17	26	27	0,8	0,3
17	20	30,5	0,8	0,3	0,5	19	29,5	30,5	0,8	0,3
20	25	36,5	0,8	0,3	0,5	22	35	37	0,8	0,3
22	28	38,5	0,8	0,3	0,5	24	37,5	39	0,8	0,3
25	30	42	0,8	0,3	0,5	25	41	42	0,8	0,3
30	35	47,5	0,8	0,3	0,5	32	46,5	47,5	0,8	0,3
35	40	50,5	0,8	0,3	0,5	37	49,5	50,5	0,8	0,3
40	45	58	0,8	0,3	0,5	42	57	58	0,8	0,3

¹⁾ Permissible axial displacement from the normal position of one bearing ring relative to the other.

6.9 Needle roller / angular contact ball bearings d 12 – 55 mm

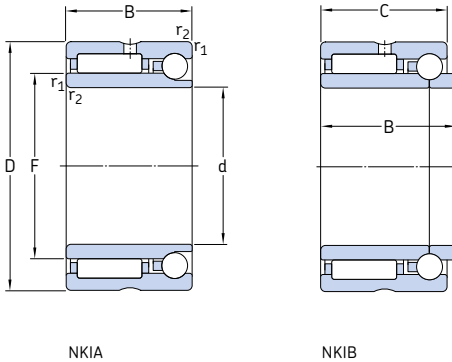

Principal dimensions				Basic load ratings				Fatigue load limits		Speed ratings		Mass	Designation	
d	D	B	C	radial dynamic C	static C ₀	axial dynamic C	static C ₀	radial P _u	axial P _u	Reference speed	Limiting speed	kg	-	
mm				kN				kN	kN	r/min			kg	-
12	24	16	-	8,09	9,65	2,07	1,92	1,14	0,083	22 000	26 000	0,04	NKIA 5901	
	24	17,5	16	8,09	9,65	2,07	1,92	1,14	0,083	22 000	26 000	0,043	NKIB 5901	
15	28	18	-	11,2	15,3	2,27	2,37	1,83	0,099	19 000	22 000	0,05	NKIA 5902	
	28	20	18	11,2	15,3	2,27	2,37	1,83	0,099	19 000	22 000	0,052	NKIB 5902	
17	30	18	-	11,4	16,3	2,24	2,74	1,96	0,116	18 000	20 000	0,056	NKIA 5903	
	30	20	18	11,4	16,3	2,24	2,74	1,96	0,116	18 000	20 000	0,058	NKIB 5903	
20	37	23	-	21,6	28	3,79	4,21	3,35	0,176	15 000	17 000	0,1	NKIA 5904	
	37	25	23	21,6	28	3,79	4,21	3,35	0,176	15 000	17 000	0,11	NKIB 5904	
22	39	23	-	23,3	32	4,14	4,93	3,9	0,205	14 000	15 000	0,12	NKIA 59/22	
	39	25	23	23,3	32	4,14	4,93	3,9	0,205	14 000	15 000	0,12	NKIB 59/22	
25	42	23	-	24,2	34,5	4,24	5,26	4,15	0,224	13 000	15 000	0,13	NKIA 5905	
	42	25	23	24,2	34,5	4,24	5,26	4,15	0,224	13 000	15 000	0,13	NKIB 5905	
30	47	23	-	25,5	39	4,54	6,32	4,65	0,268	11 000	13 000	0,15	NKIA 5906	
	47	25	23	25,5	39	4,54	6,32	4,65	0,268	11 000	13 000	0,15	NKIB 5906	
35	55	27	-	31,9	54	5,83	8,42	6,7	0,355	9 500	11 000	0,24	NKIA 5907	
	55	30	27	31,9	54	5,83	8,42	6,7	0,355	9 500	11 000	0,25	NKIB 5907	
40	62	30	-	42,9	71	7,17	10,9	8,8	0,467	8 000	9 500	0,32	NKIA 5908	
	62	34	30	42,9	71	7,17	10,9	8,8	0,467	8 000	9 500	0,32	NKIB 5908	
45	68	30	-	45,7	78	7,47	12	9,65	0,513	7 500	8 500	0,38	NKIA 5909	
	68	34	30	45,7	78	7,47	12	9,65	0,513	7 500	8 500	0,38	NKIB 5909	
50	72	30	-	47,3	85	7,74	13,7	10,6	0,579	7 000	8 000	0,38	NKIA 5910	
	72	34	30	47,3	85	7,74	13,7	10,6	0,579	7 000	8 000	0,39	NKIB 5910	
55	80	34	-	57,2	106	9,27	16,7	13,2	0,697	6 300	7 000	0,55	NKIA 5911	
	80	38	34	57,2	106	9,27	16,7	13,2	0,697	6 300	7 000	0,56	NKIB 5911	

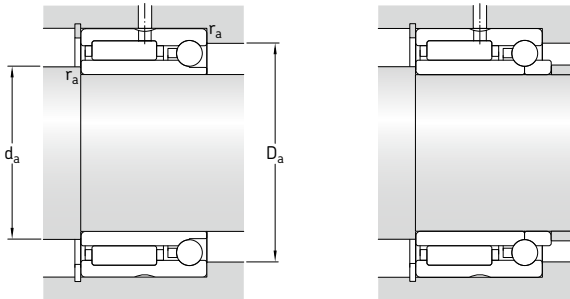
**Dimensions****Abutment and fillet dimensions**

d	F	$r_{1,2}$ min.	d_a min.	D_a max.	r_a max.
mm			mm		
12	16	0,3	14	22	0,3
	16	0,3	14	22	0,3
15	20	0,3	17	26	0,3
	20	0,3	17	26	0,3
17	22	0,3	19	28	0,3
	22	0,3	19	28	0,3
20	25	0,3	22	35	0,3
	25	0,3	22	35	0,3
22	28	0,3	24	37	0,3
	28	0,3	24	37	0,3
25	30	0,3	27	40	0,3
	30	0,3	27	40	0,3
30	35	0,3	32	45	0,3
	35	0,3	32	45	0,3
35	42	0,6	39	51	0,6
	42	0,6	39	51	0,6
40	48	0,6	44	58	0,6
	48	0,6	44	58	0,6
45	52	0,6	49	64	0,6
	52	0,6	49	64	0,6
50	58	0,6	54	68	0,6
	58	0,6	54	68	0,6
55	63	1	60	75	1
	63	1	60	75	1

6.9 Needle roller / angular contact ball bearings d 60 – 70 mm

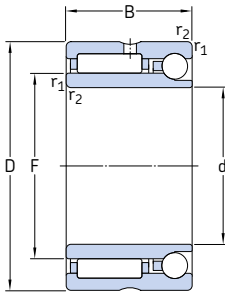

NKIA

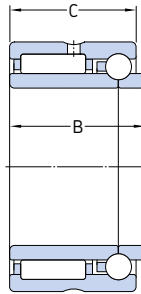

NKIB

Principal dimensions				Basic load ratings				Fatigue load limits		Speed ratings		Mass	Designation	
d	D	B	C	radial dynamic C	static C ₀	axial dynamic C	static C ₀	radial P _u	axial P _u	Reference speed	Limiting speed	kg	–	
mm				kN				kN	kN	r/min			kg	–
60	85	34	–	60,5	114	9,58	18	14,3	0,77	6 000	6 700	0,59	NKIA 5912	
	85	38	34	60,5	114	9,58	18	14,3	0,77	6 000	6 700	0,6	NKIB 5912	
65	90	34	–	61,6	120	9,96	19,2	14,6	0,816	5 600	6 300	0,64	NKIA 5913	
	90	38	34	61,6	120	9,96	19,2	14,6	0,816	5 600	6 300	0,64	NKIB 5913	
70	100	40	–	84,2	163	13,2	25	20,8	1,05	5 000	5 600	0,98	NKIA 5914	
	100	45	40	84,2	163	13,2	25	20,8	1,05	5 000	5 600	0,99	NKIB 5914	

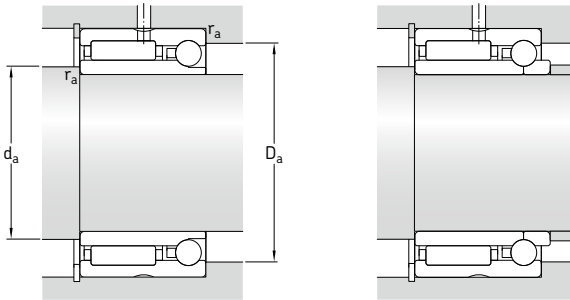
**Dimensions****Abutment and fillet dimensions**

d	F	r _{1,2} min.	d _a min.	D _a max.	r _a max.
mm		mm			
60	68	1	65	80	1
	68	1	65	80	1
65	72	1	70	85	1
	72	1	70	85	1
70	80	1	75	95	1
	80	1	75	95	1

6.10 Needle roller / thrust ball bearings, full complement thrust bearing

F_w 7 – 35 mm

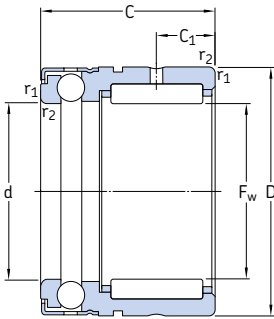

NX

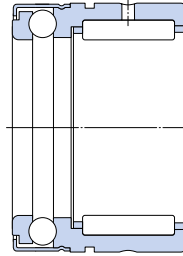

NX...Z

Principal dimensions			Basic load ratings				Fatigue load limits		Min. load factor	Speed ratings		Mass	Designation
F_w	D	C	radial dynamic C	static C_0	axial dynamic C	static C_0	radial P_u	axial P_u	A	Reference speed	Limiting speed	kg	-
mm			kN				kN	kN	-	r/min		kg	-
7	14	18	2,81	2,75	3,45	5	0,29	0,186	0,13	10 000	11 000	0,014	NX 7 TN ¹⁾ NX 7 ZTN ¹⁾
	14	18	2,81	2,75	3,45	5	0,29	0,186	0,13	10 000	6 000	0,014	
10	19	18	4,95	4,55	5,07	8,5	0,53	0,31	0,38	8 500	9 500	0,025	NX 10 NX 10 Z
	19	18	4,95	4,55	5,07	8,5	0,53	0,31	0,38	8 500	5 600	0,025	
12	21	18	5,39	5,2	5,27	9,65	0,61	0,355	0,48	8 000	9 000	0,028	NX 12 NX 12 Z
	21	18	5,39	5,2	5,27	9,65	0,61	0,355	0,48	8 000	5 300	0,028	
15	24	28	11	14	6,18	12,2	1,66	0,45	0,77	7 500	8 500	0,048	NX 15 NX 15 Z
	24	28	11	14	6,18	12,2	1,66	0,45	0,77	7 500	5 300	0,048	
17	26	28	12,1	16,6	6,37	13,4	1,96	0,5	0,93	7 000	8 500	0,053	NX 17 NX 17 Z
	26	28	12,1	16,6	6,37	13,4	1,96	0,5	0,93	7 000	5 000	0,053	
20	30	28	13,2	19,3	7,8	17,3	2,28	0,64	1,6	6 300	7 500	0,068	NX 20 NX 20 Z
	30	28	13,2	19,3	7,8	17,3	2,28	0,64	1,6	6 300	4 500	0,068	
25	37	30	15,1	24,5	12,4	28,5	2,9	1,06	4,2	5 600	6 300	0,12	NX 25 NX 25 Z
	37	30	15,1	24,5	12,4	28,5	2,9	1,06	4,2	5 600	3 800	0,12	
30	42	30	22,9	38	12,7	32,5	4,8	1,2	5,5	5 300	6 000	0,13	NX 30 NX 30 Z
	42	30	22,9	38	12,7	32,5	4,8	1,2	5,5	5 300	3 600	0,13	
35	47	30	24,6	45	13,5	38	5,6	1,4	7,5	5 000	5 600	0,16	NX 35 NX 35 Z
	47	30	24,6	45	13,5	38	5,6	1,4	7,5	5 000	3 400	0,16	

¹⁾ Radial bearing with inserted closure ring.

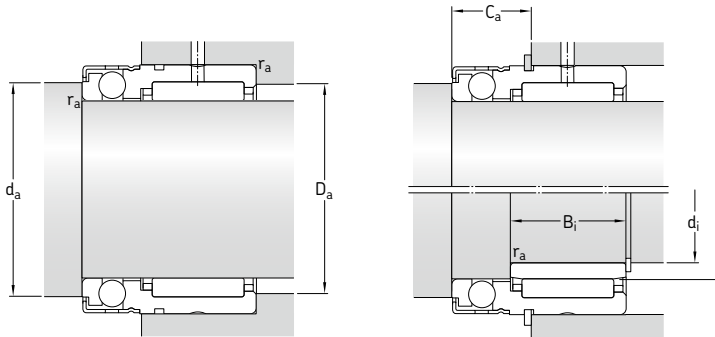

Dimensions				Abutment and fillet dimensions				Appropriate inner ring ¹⁾ Dimensions				Appropriate snap ring ²⁾ Designation
F _w	C ₁	d	r _{1,2} min.	d _a min.	D _a max.	C _a	r _a max.	d _i	F	B _i		
mm												
7	4,7	7	0,3	9,6	12	10	0,3	-	-	-	-	SW 14
	4,7	7	0,3	9,6	12	10	0,3	-	-	-	-	SW 14
10	4,7	10	0,3	14,6	17	10	0,3	6	10	10	IR 6x10x10 IS1	SW 19
	4,7	10	0,3	14,6	17	10	0,3	6	10	10	IR 6x10x10 IS1	SW 19
12	4,7	12	0,3	16,6	19	10	0,3	8	12	10	IR 8x12x10 IS1	SW 21
	4,7	12	0,3	16,6	19	10	0,3	8	12	10	IR 8x12x10 IS1	SW 21
15	8	15	0,3	19	22	12,2	0,3	12	15	16	IR 12x15 x16	SW 24
	8	15	0,3	19	22	12,2	0,3	12	15	16	IR 12x15 x16	SW 24
17	8	17	0,3	21	24	12,2	0,3	14	17	17	IR 14x17x17	SW 26
	8	17	0,3	21	24	12,2	0,3	14	17	17	IR 14x17x17	SW 26
20	8	20	0,3	25	28	12,2	0,3	17	20	16	IR 17x20 x16	SW 30
	8	20	0,3	25	28	12,2	0,3	17	20	16	IR 17x20 x16	SW 30
25	8	25	0,3	31,6	35	14,2	0,3	20	25	16	IR 20x25x16 IS1	SW 37
	8	25	0,3	31,6	35	14,2	0,3	20	25	16	IR 20x25x16 IS1	SW 37
30	10	30	0,3	36,5	40	14,2	0,3	25	30	20	IR 25x30x20	SW 42
	10	30	0,3	36,5	40	14,2	0,3	25	30	20	IR 25x30x20	SW 42
35	10	35	0,3	40,5	45	14,2	0,3	30	35	20	IR 30x35 x20	SW 47
	10	35	0,3	40,5	45	14,2	0,3	30	35	20	IR 30x35 x20	SW 47

¹⁾ For additional information, refer to *Needle roller bearing inner rings* (→ page 691).

²⁾ In accordance with DIN 471, not supplied by SKF.

6.11 Needle roller / thrust ball bearings, thrust bearing with a cage

F_w 10 – 70 mm

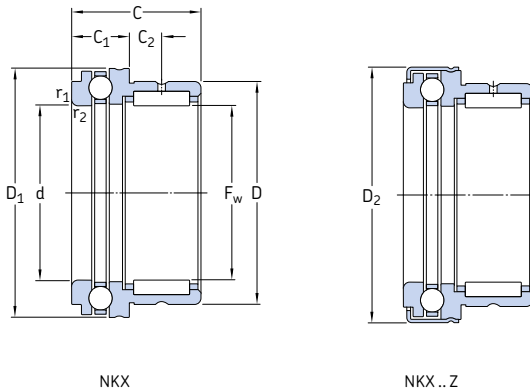

Principal dimensions			Basic load ratings				Fatigue load limits		Min. load factor	Speed ratings		Mass	Designation
F _w	D	C	radial dynamic C	static C ₀	axial dynamic C	static C ₀	radial P _u	axial P _u	A	Reference speed	Limiting speed	kg	-
mm			kN				kN	kN	-	r/min		kg	-
10	19	23	5,94	8	9,95	15,3	0,9	0,56	1,2	9 500	13 000	0,034	NKX 10 TN ¹⁾ NKX 10 ZTN ¹⁾
	19	23	5,94	8	9,95	15,3	0,9	0,56	1,2	9 500	8 000	0,036	
12	21	23	9,13	12	10,4	16,6	1,43	0,62	1,4	9 000	13 000	0,038	NKX 12 NKX 12 Z
	21	23	9,13	12	10,4	16,6	1,43	0,62	1,4	9 000	7 500	0,04	
15	24	23	11	14	10,6	18,3	1,66	0,67	1,7	8 500	12 000	0,044	NKX 15 NKX 15 Z
	24	23	11	14	10,6	18,3	1,66	0,67	1,7	8 500	7 000	0,047	
17	26	25	12,1	16,6	10,8	19,6	1,96	0,735	2	8 500	12 000	0,053	NKX 17 NKX 17 Z
	26	25	12,1	16,6	10,8	19,6	1,96	0,735	2	8 500	7 000	0,055	
20	30	30	16,5	25,5	14,3	27	3,05	1	3,8	7 500	10 000	0,083	NKX 20 NKX 20 Z
	30	30	16,5	25,5	14,3	27	3,05	1	3,8	7 500	6 000	0,09	
25	37	30	19	32,5	19,5	40,5	4	1,5	8,5	6 300	9 000	0,13	NKX 25 NKX 25 Z
	37	30	19	32,5	19,5	40,5	4	1,5	8,5	6 300	5 500	0,13	
30	42	30	22,9	38	20,3	45,5	4,8	1,7	10	6 000	8 500	0,14	NKX 30 NKX 30 Z
	42	30	22,9	38	20,3	45,5	4,8	1,7	10	6 000	5 000	0,15	
35	47	30	24,6	45	21,2	51	5,6	1,9	13	5 600	7 500	0,16	NKX 35 NKX 35 Z
	47	30	24,6	45	21,2	51	5,6	1,9	13	5 600	4 500	0,17	
40	52	32	26,4	51	27	68	6,3	2,55	24	5 000	7 000	0,2	NKX 40 NKX 40 Z
	52	32	26,4	51	27	68	6,3	2,55	24	5 000	4 000	0,21	
45	58	32	27,5	57	28,1	75	7,1	2,8	29	4 500	6 300	0,25	NKX 45 NKX 45 Z
	58	32	27,5	57	28,1	75	7,1	2,8	29	4 500	3 800	0,27	
50	62	35	38	78	28,6	81,5	9,65	3,05	34	4 300	6 300	0,28	NKX 50 NKX 50 Z
	62	35	38	78	28,6	81,5	9,65	3,05	34	4 300	3 600	0,3	
60	72	40	41,8	96,5	41,6	122	11,8	4,55	77	3 600	5 000	0,36	NKX 60 NKX 60 Z
	72	40	41,8	96,5	41,6	122	11,8	4,55	77	3 600	3 000	0,38	
70	85	40	44,6	98	43,6	137	12,2	5,1	97	3 400	4 500	0,5	NKX 70 NKX 70 Z
	85	40	44,6	98	43,6	137	12,2	5,1	97	3 400	2 700	0,52	

¹⁾ Radial bearing with inserted closure ring.

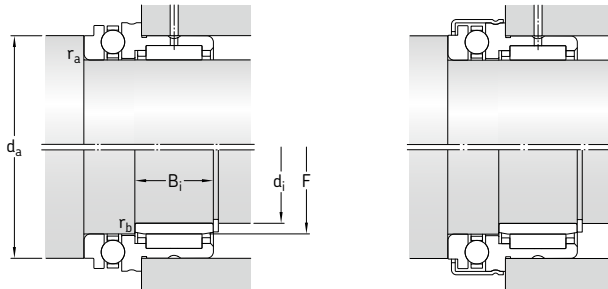

Dimensions							Abutment and fillet dimensions			Appropriate inner ring ¹⁾ Dimensions			Designation
F _w	C ₁	C ₂	d	D ₁	D ₂	r _{1,2} min.	d _a min.	r _a max.	r _b max.	d _i	F	B _i	
mm							mm			mm			-
10	9	6,5	10	24,1	-	0,3	19,7	0,3	0,3	7	10	16	IR 7x10x16
	9	6,5	10	-	25,2	0,3	19,7	0,3	0,3	7	10	16	IR 7x10x16
12	9	6,5	12	26,1	-	0,3	21,7	0,3	0,3	9	12	16	IR 9x12x16
	9	6,5	12	-	27,2	0,3	21,7	0,3	0,3	9	12	16	IR 9x12x16
15	9	6,5	15	28,1	-	0,3	23,7	0,3	0,3	12	15	16	IR 12x15x16
	9	6,5	15	-	29,2	0,3	23,7	0,3	0,3	12	15	16	IR 12x15x16
17	9	8	17	30,1	-	0,3	25,7	0,3	0,3	14	17	17	IR 14x17x17
	9	8	17	-	31,2	0,3	25,7	0,3	0,3	14	17	17	IR 14x17x17
20	10	10,5	20	35,1	-	0,3	30,7	0,3	0,3	17	20	20	IR 17x20x20
	10	10,5	20	-	36,2	0,3	30,7	0,3	0,3	17	20	20	IR 17x20x20
25	11	9,5	25	42,1	-	0,6	37,7	0,6	0,3	20	25	20	IR 20x25x20
	11	9,5	25	-	43,2	0,6	37,7	0,6	0,3	20	25	20	IR 20x25x20
30	11	9,5	30	47,1	-	0,6	42,7	0,6	0,3	25	30	20	IR 25x30x20
	11	9,5	30	-	48,2	0,6	42,7	0,6	0,3	25	30	20	IR 25x30x20
35	12	9	35	52,1	-	0,6	47,7	0,6	0,3	30	35	20	IR 30x35x20
	12	9	35	-	53,2	0,6	47,7	0,6	0,3	30	35	20	IR 30x35x20
40	13	10	40	60,1	-	0,6	55,7	0,6	0,3	35	40	20	IR 35x40x20
	13	10	40	-	61,2	0,6	55,7	0,6	0,3	35	40	20	IR 35x40x20
45	14	9	45	65,2	-	0,6	60,5	0,6	0,3	40	45	20	IR 40x45x20
	14	9	45	-	66,5	0,6	60,5	0,6	0,3	40	45	20	IR 40x45x20
50	14	10	50	70,2	-	0,6	65,5	0,6	0,6	45	50	25	IR 45x50x25
	14	10	50	-	71,5	0,6	65,5	0,6	0,6	45	50	25	IR 45x50x25
60	17	12	60	85,2	-	1	80,5	1	1	50	60	25	IR 50x60x25
	17	12	60	-	86,5	1	80,5	1	1	50	60	25	IR 50x60x25
70	18	11	70	95,2	-	1	90,5	1	1	60	70	25	IR 60x70x25
	18	11	70	-	96,5	1	90,5	1	1	60	70	25	IR 60x70x25

¹⁾ For additional information, refer to *Needle roller bearing inner rings* (→ page 691).

6.12 Needle roller / cylindrical roller thrust bearings

F_w 15 – 50 mm

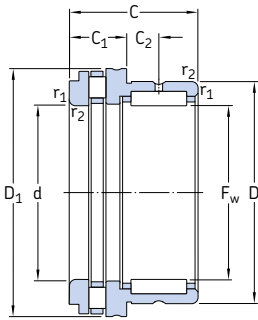

NKXR

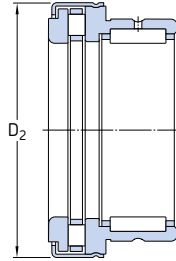

NKXR..Z

Principal dimensions			Basic load ratings				Fatigue load limits		Min. load factor A	Speed ratings		Mass	Designation
F _w	D	C	radial dynamic C	static C ₀	axial dynamic C	static C ₀	radial P _u	axial P _u		Reference speed	Limiting speed		
mm			kN				kN	kN	-	r/min		kg	-
15	24	23	11	14	11,2	27	1,66	2,45	0,058	4 300	8 500	0,042	NKXR 15
	24	23	11	14	11,2	27	1,66	2,45	0,058	4 300	8 500	0,045	NKXR 15 Z
17	26	25	12,1	16,6	12,2	31,5	1,96	2,85	0,079	4 300	8 500	0,05	NKXR 17
	26	25	12,1	16,6	12,2	31,5	1,96	2,85	0,079	4 300	8 500	0,053	NKXR 17 Z
20	30	30	16,5	25,5	18,6	48	3,05	4,65	0,18	3 800	7 500	0,08	NKXR 20
	30	30	16,5	25,5	18,6	48	3,05	4,65	0,18	3 800	7 500	0,084	NKXR 20 Z
25	37	30	19	32,5	25	69,5	4	6,8	0,39	3 200	6 300	0,12	NKXR 25
	37	30	19	32,5	25	69,5	4	6,8	0,39	3 200	6 300	0,13	NKXR 25 Z
30	42	30	22,9	38	27	78	4,8	7,65	0,49	3 000	6 000	0,14	NKXR 30
	42	30	22,9	38	27	78	4,8	7,65	0,49	3 000	6 000	0,14	NKXR 30 Z
35	47	30	24,6	45	29	93	5,6	9,15	0,69	2 800	5 600	0,16	NKXR 35
	47	30	24,6	45	29	93	5,6	9,15	0,69	2 800	5 600	0,17	NKXR 35 Z
40	52	32	26,4	51	43	137	6,3	13,7	1,5	2 400	5 000	0,2	NKXR 40
	52	32	26,4	51	43	137	6,3	13,7	1,5	2 400	5 000	0,21	NKXR 40 Z
45	58	32	27,5	57	45	153	7,1	15,3	1,85	2 200	4 500	0,24	NKXR 45
	58	32	27,5	57	45	153	7,1	15,3	1,85	2 200	4 500	0,26	NKXR 45 Z
50	62	35	38	78	47,5	166	9,65	16,6	2,2	2 200	4 300	0,27	NKXR 50
	62	35	38	78	47,5	166	9,65	16,6	2,2	2 200	4 300	0,29	NKXR 50 Z

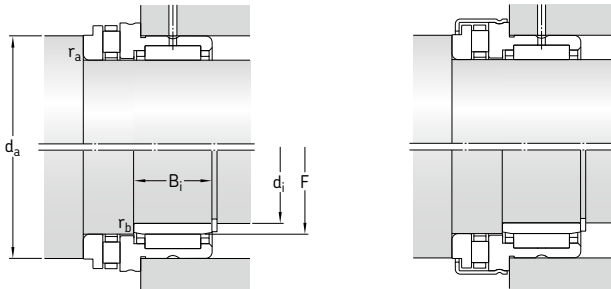

Dimensions							Abutment and fillet dimensions			Appropriate inner ring ¹⁾ Dimensions			Designation
F _w	C ₁	C ₂	d	D ₁	D ₂	r _{1,2} min.	d _a min.	r _a max.	r _b max.	d _i	F	B _i	
mm							mm			mm			-
15	9	6,5	15	28,1	-	0,3	23,7	0,3	0,3	12	15	16	IR 12x15x16
	9	6,5	15	-	29,2	0,3	23,7	0,3	0,3	12	15	16	IR 12x15x16
17	9	8	17	30,1	-	0,3	25,7	0,3	0,3	14	17	17	IR 14x17x17
	9	8	17	-	31,2	0,3	25,7	0,3	0,3	14	17	17	IR 14x17x17
20	10	10,5	20	35,1	-	0,3	30,7	0,3	0,3	17	20	20	IR 17x20x20
	10	10,5	20	-	36,2	0,3	30,7	0,3	0,3	17	20	20	IR 17x20x20
25	11	9,5	25	42,1	-	0,6	37,7	0,6	0,3	20	25	20	IR 20x25x20
	11	9,5	25	-	43,2	0,6	37,7	0,6	0,3	20	25	20	IR 20x25x20
30	11	9,5	30	47,1	-	0,6	42,7	0,6	0,3	25	30	20	IR 25x30x20
	11	9,5	30	-	48,2	0,6	42,7	0,6	0,3	25	30	20	IR 25x30x20
35	12	9	35	52,1	-	0,6	47,7	0,6	0,3	30	35	20	IR 30x35x20
	12	9	35	-	53,2	0,6	47,7	0,6	0,3	30	35	20	IR 30x35x20
40	13	10	40	60,1	-	0,6	55,7	0,6	0,3	35	40	20	IR 35x40x20
	13	10	40	-	61,2	0,6	55,7	0,6	0,3	35	40	20	IR 35x40x20
45	14	9	45	65,2	-	0,6	60,6	0,6	0,3	40	45	20	IR 40x45x20
	14	9	45	-	71,5	0,6	60,6	0,6	0,3	40	45	20	IR 40x45x20
50	14	10	50	70,2	-	0,6	65,5	0,6	0,6	45	50	25	IR 45x50x25
	14	10	50	-	71,5	0,6	65,5	0,6	0,6	45	50	25	IR 45x50x25

¹⁾ For additional information, refer to *Needle roller bearing inner rings* (→ page 691).

6.13 Needle roller bearing inner rings

d 5 – 45 mm

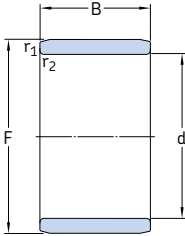

IR



IR..IS1

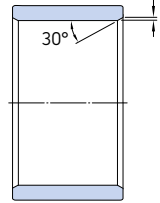

LR

Dimensions				Mass	Designation
d	F	B	r, r _{1,2} min.		
mm				kg	-
5	8	12	0,3	0,003	IR 5x8x12
	8	16	0,3	0,004	IR 5x8x16
6	9	12	0,3	0,003	IR 6x9x12
	9	16	0,3	0,004	IR 6x9x16
	10	10	0,3	0,004	IR 6x10x10
	10	10	0,3	0,004	IR 6x10x10 IS1
7	10	10,5	0,3	0,003	IR 7x10x10,5
	10	10,5	0,3	0,003	LR 7x10x10,5
	10	12	0,3	0,004	IR 7x10x12
	10	16	0,3	0,005	IR 7x10x16
8	12	10	0,3	0,005	IR 8x12x10
	12	10	0,3	0,005	IR 8x12x10 IS1
	12	10,5	0,3	0,005	IR 8x12x10,5
	12	10,5	0,3	0,005	LR 8x12x10,5
	12	12,5	0,3	0,006	IR 8x12x12,5
	12	12,5	0,3	0,006	LR 8x12x12,5
9	12	12	0,3	0,004	IR 9x12x12
	12	16	0,3	0,006	IR 9x12x16
10	13	12,5	0,3	0,005	IR 10x13x12,5
	13	12,5	0,3	0,005	LR 10x13x12,5
	14	12	0,3	0,007	IR 10x14x12 IS1
	14	13	0,3	0,007	IR 10x14x13
	14	16	0,3	0,009	IR 10x14x16
	14	20	0,3	0,012	IR 10x14x20

Dimensions				Mass	Designation
d	F	B	r, r _{1,2} min.		
mm				kg	-
12	15	12	0,3	0,006	IR 12x15x12
	15	12,5	0,3	0,006	IR 12x15x12,5
	15	12,5	0,3	0,006	LR 12x15x12,5
12	15	16	0,3	0,008	IR 12x15x16
	15	16,5	0,3	0,008	IR 12x15x16,5
	15	16,5	0,3	0,008	LR 12x15x16,5
	15	22,5	0,3	0,011	IR 12x15x22,5
	15	22,5	0,3	0,011	LR 12x15x22,5
	15	22,5	0,3	0,011	LR 12x15x22,5
12	16	12	0,3	0,008	IR 12x16x12 IS1
	16	13	0,3	0,009	IR 12x16x13
	16	16	0,3	0,011	IR 12x16x16
	16	20	0,3	0,014	IR 12x16x20
	16	22	0,3	0,015	IR 12x16x22
	16	22	0,3	0,015	IR 12x16x22
14	17	17	0,3	0,01	IR 14x17x17
15	18	12,5	0,3	0,007	LR 15x18x12,5
	18	16	0,3	0,009	IR 15x18x16
	18	16,5	0,3	0,01	IR 15x18x16,5
	18	16,5	0,3	0,01	LR 15x18x16,5
15	19	16	0,3	0,013	IR 15x19x16
	19	20	0,3	0,016	IR 15x19x20
	20	12	0,3	0,012	IR 15x20x12 IS1
	20	13	0,3	0,014	IR 15x20x13
	20	23	0,3	0,024	IR 15x20x23
	20	23	0,3	0,024	IR 15x20x23

Dimensions				Mass	Designation
d	F	B	r, r _{1,2} min.		
mm				kg	-
17	20	16	0,3	0,011	IR 17x20x16
	20	16,5	0,3	0,011	IR 17x20x16.5
	20	16,5	0,3	0,011	LR 17x20x16.5
	20	20	0,3	0,014	IR 17x20x20
	20	20,5	0,3	0,014	IR 17x20x20.5
	20	20,5	0,3	0,014	LR 17x20x20.5
	20	30,5	0,3	0,021	IR 17x20x30.5
	20	30,5	0,3	0,021	LR 17x20x30.5
	21	16	0,3	0,015	IR 17x21x16
	21	20	0,3	0,018	IR 17x21x20
	22	13	0,3	0,015	IR 17x22x13
	22	16	0,3	0,018	IR 17x22x16
22	23	0,3	0,027	IR 17x22x23	
24	20	0,6	0,034	IR 17x24x20	
20	24	16	0,3	0,015	IR 20x24x16
	24	20	0,3	0,021	IR 20x24x20
	25	12,5	0,3	0,016	LR 20x25x12.5
	25	16	0,3	0,024	IR 20x25x16 IS1
	25	16,5	0,3	0,022	LR 20x25x16.5
	25	17	0,3	0,025	IR 20x25x17
	25	20	0,3	0,028	IR 20x25x20
	25	20,5	0,3	0,027	IR 20x25x20.5
	25	20,5	0,3	0,027	LR 20x25x20.5
	25	26,5	0,3	0,038	IR 20x25x26.5
	25	26,5	0,3	0,038	LR 20x25x26.5
	25	30	0,3	0,04	IR 20x25x30
	25	38,5	0,3	0,053	IR 20x25x38.5
	25	38,5	0,3	0,053	LR 20x25x38.5
	28	20	0,6	0,045	IR 20x28x20
22	26	16	0,3	0,018	IR 22x26x16
	26	20	0,3	0,023	IR 22x26x20
	28	17	0,3	0,03	IR 22x28x17
	28	20	0,3	0,035	IR 22x28x20
	28	20,5	0,3	0,036	IR 22x28x20.5
	28	20,5	0,3	0,036	LR 22x28x20.5
28	30	0,3	0,054	IR 22x28x30	
25	29	20	0,3	0,026	IR 25x29x20
	29	30	0,3	0,039	IR 25x29x30
	30	12,5	0,3	0,02	LR 25x30x12.5
	30	16	0,3	0,026	IR 25x30x16 IS1
	30	16,5	0,3	0,027	LR 25x30x16.5
	30	17	0,3	0,027	IR 25x30x17
	30	20	0,3	0,033	IR 25x30x20
	30	20,5	0,3	0,033	IR 25x30x20.5
	30	20,5	0,3	0,033	LR 25x30x20.5
	30	26,5	0,3	0,046	IR 25x30x26.5
	30	26,5	0,3	0,046	LR 25x30x26.5
	30	30	0,3	0,053	IR 25x30x30
	30	32	0,3	0,056	IR 25x30x32
	30	38,5	0,3	0,065	IR 25x30x38.5
	30	38,5	0,3	0,065	LR 25x30x38.5
32	22	0,6	0,053	IR 25x32x22	
28	32	17	0,3	0,025	IR 28x32x17
	32	20	0,3	0,029	IR 28x32x20
	32	30	0,3	0,044	IR 28x32x30

Dimensions				Mass	Designation
d	F	B	r, r _{1,2} min.		
mm				kg	-
30	35	12,5	0,3	0,023	LR 30x35x12.5
	35	13	0,3	0,025	IR 30x35x13
	35	16	0,3	0,034	IR 30x35x16
	35	16,5	0,3	0,031	LR 30x35x16.5
	35	17	0,3	0,036	IR 30x35x17
	35	20	0,3	0,039	IR 30x35x20
	35	20,5	0,3	0,04	IR 30x35x20.5
	35	20,5	0,3	0,04	LR 30x35x20.5
	35	26	0,3	0,05	IR 30x35x26
	35	30	0,3	0,059	IR 30x35x30
	37	18	0,6	0,05	IR 30x37x18
	37	22	0,6	0,062	IR 30x37x22
38	20	0,6	0,077	IR 30x38x20 IS1	
32	37	20	0,3	0,042	IR 32x37x20
	37	30	0,3	0,062	IR 32x37x30
	40	20	0,6	0,068	IR 32x40x20
	40	36	0,6	0,12	IR 32x40x36
33	37	13	0,3	0,022	IR 33x37x13
35	40	12,5	0,3	0,027	LR 35x40x12.5
	40	16,5	0,3	0,037	LR 35x40x16.5
	40	17	0,3	0,038	IR 35x40x17
	40	20	0,3	0,044	IR 35x40x20
	40	20,5	0,3	0,046	IR 35x40x20.5
	40	20,5	0,3	0,046	LR 35x40x20.5
	40	30	0,3	0,067	IR 35x40x30
	42	20	0,6	0,064	IR 35x42x20 IS1
	42	36	0,6	0,12	IR 35x42x36
	43	22	0,6	0,082	IR 35x43x22
38	43	20	0,3	0,048	IR 38x43x20
	43	30	0,3	0,074	IR 38x43x30
40	45	16,5	0,3	0,041	LR 40x45x16.5
	45	17	0,3	0,043	IR 40x45x17
	45	20	0,3	0,051	IR 40x45x20
	45	20,5	0,3	0,052	IR 40x45x20.5
	45	20,5	0,3	0,052	LR 40x45x20.5
	45	30	0,3	0,084	IR 40x45x30
	48	22	0,6	0,092	IR 40x48x22
48	40	0,6	0,17	IR 40x48x40	
50	20	1	0,11	IR 40x50x20 IS1	
50	22	1	0,12	IR 40x50x22	
42	47	20	0,3	0,053	IR 42x47x20
	47	30	0,3	0,081	IR 42x47x30
45	50	20,5	0,3	0,059	LR 45x50x20.5
	50	25	0,6	0,071	IR 45x50x25
	50	25,5	0,3	0,075	IR 45x50x25.5
	50	25,5	0,3	0,075	LR 45x50x25.5
	50	35	0,6	0,1	IR 45x50x35
	52	22	0,6	0,089	IR 45x52x22
52	40	0,6	0,16	IR 45x52x40	
55	20	1	0,12	IR 45x55x20 IS1	
55	22	1	0,13	IR 45x55x22	

6.13

6.13 Needle roller bearing inner rings d 50 – 380 mm

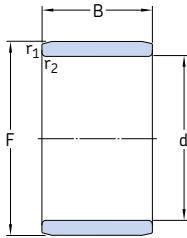

IR



IR..IS1

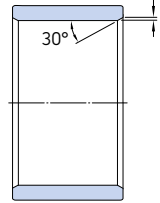

LR

Dimensions				Mass	Designation
d	F	B	r, r _{1,2} min.		
mm				kg	-
50	55	20	0,6	0,063	IR 50x55x20 IS1
	55	20,5	0,6	0,064	LR 50x55x20.5
	55	25	0,6	0,078	IR 50x55x25
	55	35	0,6	0,11	IR 50x55x35
55	58	22	0,6	0,12	IR 50x58x22
	58	40	0,6	0,21	IR 50x58x40
	60	20	1	0,13	IR 50x60x20 IS1
	60	25	1	0,16	IR 50x60x25
60	60	28	1,1	0,18	IR 50x60x28
	60	25	0,6	0,086	IR 55x60x25
	60	35	0,6	0,12	IR 55x60x35
	63	25	1	0,14	IR 55x63x25
65	63	45	1	0,26	IR 55x63x45
	65	28	1,1	0,2	IR 55x65x28
	68	25	1	0,15	IR 60x68x25
	68	35	0,6	0,21	IR 60x68x35
70	68	45	1	0,28	IR 60x68x45
	70	25	1	0,2	IR 60x70x25
	70	28	1,1	0,22	IR 60x70x28
	72	25	1	0,14	IR 65x72x25
75	72	45	1	0,26	IR 65x72x45
	73	25	1	0,16	IR 65x73x25
	73	35	1	0,23	IR 65x73x35
	75	28	1,1	0,23	IR 65x75x28
80	80	25	1	0,22	IR 70x80x25
	80	30	1	0,27	IR 70x80x30
	80	35	1	0,31	IR 70x80x35
	80	54	1	0,49	IR 70x80x54
85	85	25	1	0,24	IR 75x85x25
	85	30	1	0,29	IR 75x85x30
	85	35	1	0,34	IR 75x85x35
	85	54	1	0,52	IR 75x85x54

Dimensions				Mass	Designation
d	F	B	r, r _{1,2} min.		
mm				kg	-
80	90	25	1	0,25	IR 80x90x25
	90	30	1	0,3	IR 80x90x30
	90	35	1	0,36	IR 80x90x35
	90	54	1	0,56	IR 80x90x54
85	95	26	1	0,28	IR 85x95x26
	95	36	1	0,39	IR 85x95x36
	100	35	1,1	0,58	IR 85x100x35
	100	63	1,1	1,05	IR 85x100x63
90	100	26	1	0,29	IR 90x100x26
	100	30	1	0,34	IR 90x100x30
	100	36	1	0,41	IR 90x100x36
	105	35	1,1	0,61	IR 90x105x35
95	105	63	1,1	1,1	IR 90x105x63
	105	26	1	0,31	IR 95x105x26
	105	36	1	0,43	IR 95x105x36
	110	35	1,1	0,66	IR 95x110x35
100	110	63	1,1	1,15	IR 95x110x63
	110	30	1,1	0,35	IR 100x110x30
	110	40	1,1	0,51	IR 100x110x40
	115	40	1,1	0,78	IR 100x115x40
110	120	30	1	0,41	IR 110x120x30
	125	40	1,1	0,84	IR 110x125x40
120	130	30	1	0,44	IR 120x130x30
	135	45	1,1	1,05	IR 120x135x45
130	145	35	1,1	0,86	IR 130x145x35
	150	50	1,5	1,7	IR 130x150x50
140	155	35	1,1	0,92	IR 140x155x35
	160	50	1,5	1,8	IR 140x160x50
150	165	40	1,1	1,1	IR 150x165x40
160	175	40	1,1	1,2	IR 160x175x40
170	185	45	1,1	1,45	IR 170x185x45

Dimensions				Mass	Designation
d	F	B	r, r _{1,2} min.		
mm				kg	-
180	195	45	1,1	1,5	IR 180x195x45
190	210	50	1,5	2,4	IR 190x210x50
200	220	50	1,5	2,5	IR 200x220x50
220	240	50	1,5	2,75	IR 220x240x50
240	265	60	2	4,6	IR 240x265x60
260	285	60	2	5	IR 260x285x60
280	305	69	2	6,1	IR 280x305x69
300	330	80	2,1	9,2	IR 300x330x80
320	350	80	2,1	9,8	IR 320x350x80
340	370	80	2,1	10	IR 340x370x80
360	390	80	2,1	11	IR 360x390x80
380	415	100	2,1	16,5	IR 380x415x100

6.13

6.14 Needle rollers

D_w 1 – 6 mm

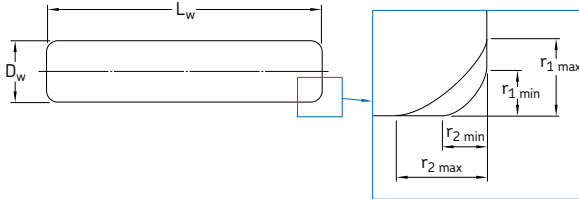

Dimensions					Mass	Designation	Dimensions					Mass	Designation
D_w	L_w	$r_{1,2}$ min.	r_1 max.	r_2 max.	g	-	D_w	L_w	$r_{1,2}$ min.	r_1 max.	r_2 max.	g	-
mm	mm	mm	mm	mm	g	-	mm	mm	mm	mm	mm	g	-
1	7,8	0,1	0,4	0,6	0,048	RN-1x7,8 BF/G2	3,5	11,8	0,3	0,8	1	0,89	RN-3,5x11,8 BF/G2
1,5	5,8	0,1	0,4	0,6	0,081	RN-1,5x5,8 BF/G2	13,8	0,3	0,8	1	1,05	RN-3,5x13,8 BF/G2	
	6,8	0,1	0,4	0,6	0,094	RN-1,5x6,8 BF/G2	15,8	0,3	0,8	1	1,2	RN-3,5x15,8 BF/G2	
	7,8	0,1	0,4	0,6	0,11	RN-1,5x7,8 BF/G2	17,8	0,3	0,8	1	1,35	RN-3,5x17,8 BF/G2	
	9,8	0,1	0,4	0,6	0,14	RN-1,5x9,8 BF/G2	19,8	0,3	0,8	1	1,5	RN-3,5x19,8 BF/G2	
	11,8	0,1	0,4	0,6	0,16	RN-1,5x11,8 BF/G2	21,8	0,3	0,8	1	1,65	RN-3,5x21,8 BF/G2	
13,8	0,1	0,4	0,6	0,19	RN-1,5x13,8 BF/G2	29,8	0,3	0,8	1	2,25	RN-3,5x29,8 BF/G2		
2	6,3	0,2	0,6	0,8	0,16	RN-2x6,3 BF/G2	34,8	0,3	0,8	1	2,65	RN-3,5x34,8 BF/G2	
	7,8	0,2	0,6	0,8	0,19	RN-2x7,8 BF/G2	4	11,8	0,3	0,8	1	1,15	RN-4x11,8 BF/G2
	9,8	0,2	0,6	0,8	0,24	RN-2x9,8 BF/G2	13,8	0,3	0,8	1	1,35	RN-4x13,8 BF/G2	
	11,8	0,2	0,6	0,8	0,29	RN-2x11,8 BF/G2	15,8	0,3	0,8	1	1,55	RN-4x15,8 BF/G2	
	13,8	0,2	0,6	0,8	0,34	RN-2x13,8 BF/G2	17,8	0,3	0,8	1	1,75	RN-4x17,8 BF/G2	
15,8	0,2	0,6	0,8	0,39	RN-2x15,8 BF/G2	19,8	0,3	0,8	1	1,95	RN-4x19,8 BF/G2		
2,5	7,8	0,2	0,6	0,8	0,3	RN-2,5x7,8 BF/G2	21,8	0,3	0,8	1	2,15	RN-4x21,8 BF/G2	
	9,8	0,2	0,6	0,8	0,38	RN-2,5x9,8 BF/G2	23,8	0,3	0,8	1	2,35	RN-4x23,8 BF/G2	
	11,8	0,2	0,6	0,8	0,45	RN-2,5x11,8 BF/G2	25,8	0,3	0,8	1	2,55	RN-4x25,8 BF/G2	
	13,8	0,2	0,6	0,8	0,53	RN-2,5x13,8 BF/G2	27,8	0,3	0,8	1	2,75	RN-4x27,8 BF/G2	
	15,8	0,2	0,6	0,8	0,61	RN-2,5x15,8 BF/G2	29,8	0,3	0,8	1	2,95	RN-4x29,8 BF/G2	
3	7,8	0,2	0,6	0,8	0,3	RN-2,5x7,8 BF/G2	34,8	0,3	0,8	1	3,45	RN-4x34,8 BF/G2	
	9,8	0,2	0,6	0,8	0,38	RN-2,5x9,8 BF/G2	39,8	0,3	0,8	1	3,95	RN-4x39,8 BF/G2	
	11,8	0,2	0,6	0,8	0,45	RN-2,5x11,8 BF/G2	5	15,8	0,3	0,8	1	2,45	RN-5x15,8 BF/G2
	13,8	0,2	0,6	0,8	0,53	RN-2,5x13,8 BF/G2	19,8	0,3	0,8	1	3,05	RN-5x19,8 BF/G2	
	15,8	0,2	0,6	0,8	0,61	RN-2,5x15,8 BF/G2	21,8	0,3	0,8	1	3,35	RN-5x21,8 BF/G2	
3,5	7,8	0,2	0,6	0,8	0,3	RN-2,5x7,8 BF/G2	23,8	0,3	0,8	1	3,65	RN-5x23,8 BF/G2	
	9,8	0,2	0,6	0,8	0,38	RN-2,5x9,8 BF/G2	25,8	0,3	0,8	1	4	RN-5x25,8 BF/G2	
	11,8	0,2	0,6	0,8	0,45	RN-2,5x11,8 BF/G2	27,8	0,3	0,8	1	4,3	RN-5x27,8 BF/G2	
	13,8	0,2	0,6	0,8	0,53	RN-2,5x13,8 BF/G2	29,8	0,3	0,8	1	4,6	RN-5x29,8 BF/G2	
	15,8	0,2	0,6	0,8	0,61	RN-2,5x15,8 BF/G2	34,8	0,3	0,8	1	5,35	RN-5x34,8 BF/G2	
4	7,8	0,2	0,6	0,8	0,3	RN-2,5x7,8 BF/G2	39,8	0,3	0,8	1	6,15	RN-5x39,8 BF/G2	
	9,8	0,2	0,6	0,8	0,38	RN-2,5x9,8 BF/G2	6	17,8	0,3	0,8	1	3,95	RN-6x17,8 BF/G2
	11,8	0,2	0,6	0,8	0,45	RN-2,5x11,8 BF/G2	21,8	0,2	0,6	0,8	1,2	RN-3x21,8 BF/G2	
	13,8	0,2	0,6	0,8	0,53	RN-2,5x13,8 BF/G2	23,8	0,2	0,6	0,8	1,3	RN-3x23,8 BF/G2	
	15,8	0,2	0,6	0,8	0,61	RN-2,5x15,8 BF/G2							



7 Tapered roller bearings

Designs and variants	798
Basic design bearings.	800
TQ-line bearings.	800
Bearings with a QCL7C designation suffix.	800
Application specific bearings	801
Bearings with a flanged outer ring	801
Matched bearings.	802
Cages.	803
Performance classes	804
SKF Explorer bearings	804
SKF Energy Efficient (E2) bearings	804
Bearing data	807
(Dimension standards, tolerances, internal clearance, preload, misalignment, friction, defect frequencies)	
Loads	811
(Minimum load, equivalent loads) Calculating the axial load for bearings mounted singly or paired in tandem	812
Calculating the radial load acting on matched bearings	814
Temperature limits.	816
Permissible speed.	816
Design of bearing arrangements	816
Fits for inch bearings	816
Fits for matched bearings	817
Adjustment procedure	817
Bearing designations	820
Metric bearings.	820
Inch bearings	821
Designation system	822

Product tables	
7.1 Metric single row tapered roller bearings.	824
7.2 Inch single row tapered roller bearings.	842
7.3 Single row tapered roller bearings with a flanged outer ring	864
7.4 Matched bearings arranged face-to-face	866
7.5 Matched bearings arranged back-to-back.	872
7.6 Matched bearings arranged in tandem	876

Other tapered roller bearings	
Bearings with Solid Oil	1185
SKF DryLube bearings	1191
Double row tapered roller bearings → skf.com/bearings	
Four-row tapered roller bearings → skf.com/bearings	
Hub bearing units for passenger cars → contact SKF	
Hub bearing units for trucks → contact SKF	
Tapered roller bearing units for rail-bound vehicles → contact SKF	
Units for transmission and engine applications → contact SKF	



Designs and variants

Tapered roller bearings have tapered inner and outer ring raceways and tapered rollers. They are designed to accommodate combined loads, i.e. simultaneously acting radial and axial loads. The projection lines of the raceways meet at a common point on the bearing axis (→ **fig. 1**) to provide true rolling and low friction. The axial load carrying capacity of tapered roller bearings increases with increasing contact angle α . The size of the angle is related to the calculation factor e (→ **product tables**): the larger the value of e , the larger the contact angle. A single row tapered roller bearing is typically adjusted against a second tapered roller bearing.

Single row tapered roller bearings are separable (→ **fig. 2**), i.e. the inner ring with roller and cage assembly (cone) can be mounted separately from the outer ring (cup).

The factors that influence SKF bearing performance and service life include but are not limited to the following:

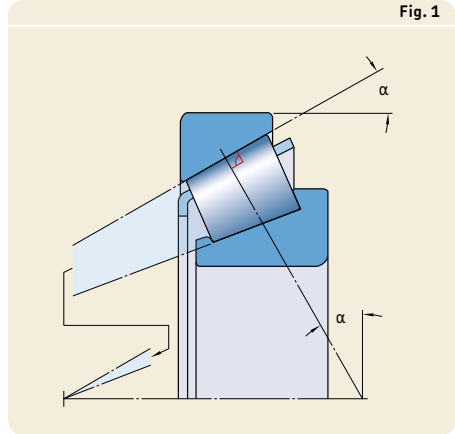

- **roller end / flange contact area**

The geometry and surface finish of the roller ends and the area on the flange that makes contact with the roller ends (→ **fig. 3**) have been optimized to promote and maintain the formation of a lubricant film. This reduces friction and frictional heat as well as flange wear. The bearings can better maintain preload and run at reduced noise levels.

- **raceway profiles**

To extend service life under misalignment or heavy load conditions, SKF tapered roller bearings have either crowned raceways or a logarithmic profile to prevent stress peaks at the roller ends. The logarithmic profile is designed to optimize load distribution along the rollers.

- **consistency of profiles and roller size**

The rollers used in SKF tapered roller bearings are made to such close tolerances that they are virtually identical. These extremely close tolerances, together with the precision of the raceway profiles, provide optimal load distribution over the rollers to reduce noise and vibration levels and enable preload to be set more accurately.

More information

Bearing life and load ratings **63**

Design considerations **159**

Bearing systems 160

Recommended fits 169

Abutment and fillet dimensions 208

Lubrication **239**

Mounting, dismantling and bearing care **271**

Mounting instructions for individual bearings → skf.com/mount

SKF bearing maintenance handbook (ISBN 978-91-978966-4-1)

Running-in

Tapered roller bearings typically have a running-in period. During the running-in period, a conventional design tapered roller bearing experiences a significant amount of friction, resulting in wear, which can be noticed as a temperature spike (→ **diagram 1**). With current SKF tapered roller bearing designs, friction, wear and frictional heat are significantly reduced, provided the bearings are mounted and lubricated correctly.

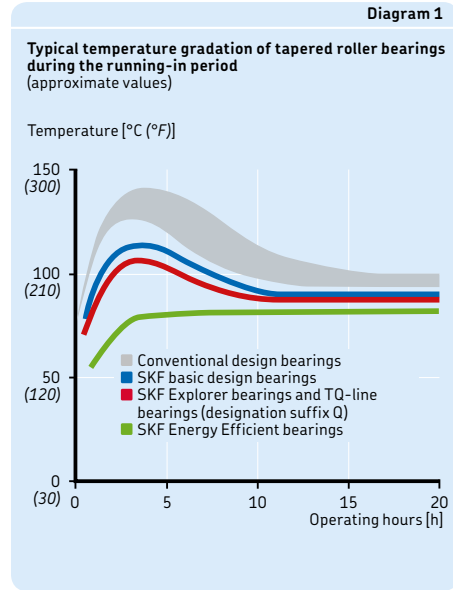

7

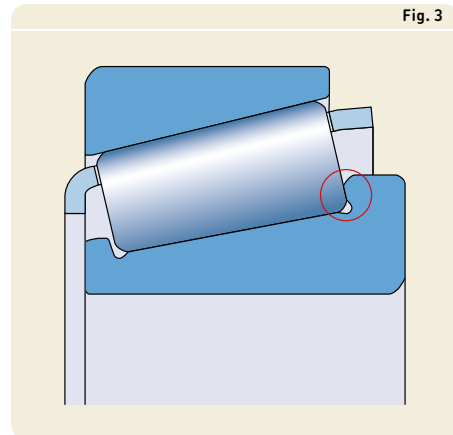
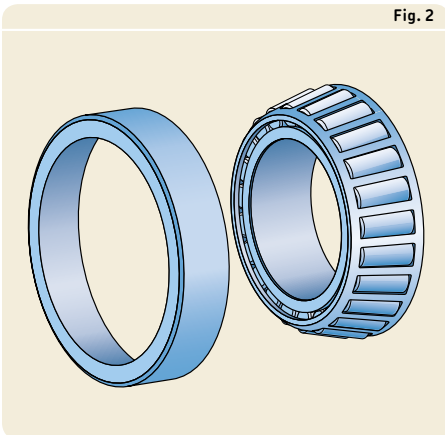

7 Tapered roller bearings

Assortment

The assortment listed in this catalogue comprises popular sizes of metric single row tapered roller bearings in accordance with ISO 355 and inch bearings in accordance with ANSI/ABMA Standard 19.2. It includes:

- basic design bearings
- TQ-line bearings (designation suffix Q)
- bearings with a flanged outer ring
- matched bearings

Tapered roller bearings listed in this catalogue constitute the basic SKF assortment and are only part of the total assortment. For information about

- other sizes of single row tapered roller bearings, refer to the product information available online at skf.com/bearings.
- double row and four-row tapered roller bearings, refer to the product information available online at skf.com/bearings.
- hub units based on tapered roller bearings for industrial, automotive, railway and off-highway applications, contact SKF.

Basic design bearings

The design and internal geometry of SKF basic design tapered roller bearings (→ **fig. 4**) enable these bearings to provide long service life. The crowned profile of the raceways and optimized surface finish of the inner ring guide flange enables these bearings to run cooler and consume less lubricant than conventional design bearings.

TQ-line bearings

TQ-line tapered roller bearings (→ **fig. 4**) are identified by the designation suffix Q and have operating characteristics that clearly set them apart from bearings made to conventional designs. The logarithmic contact profile provides optimum load distribution in the roller / raceway contact area to keep stress peaks within acceptable limits, even under slight misalignment. Like SKF Explorer bearings, the roller end / flange contact area of TQ-line tapered roller bearings is designed to reduce friction and wear at start-up. Normally the bearings do not need running-in procedures after installation. Bearings that are preloaded experience only a small, controlled loss of initial preload.

Bearings with a QCL7C designation suffix

Bearings identified by the designation suffix QCL7C were originally designed for use as pinion bearings in the differential of industrial transmissions to provide a constant, accurate gear mesh. The bearings are characterized by their high degree of running accuracy and high preload capability. They have special friction characteristics and can be axially adjusted within narrow limits using the friction-torque method. Their internal design promotes the formation of a hydrodynamic oil film to substantially reduce friction and consequently operating temperature during the running-in period. When installed, lubricated and maintained properly, bearings with a designation suffix QCL7C retain their preload setting.

Fig. 4

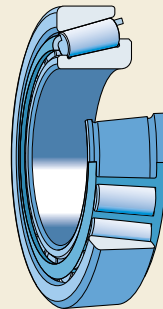

Application specific bearings

For applications where the bearings are subjected to unique operating conditions, SKF can customize TQ-line bearings (designation suffix Q) to meet the needs of that particular application.

For additional information about application specific tapered roller bearings, contact the SKF application engineering service.

Bearings with a flanged outer ring

Certain sizes of SKF single row tapered roller bearings are also available with a flange on the outer ring (→ **fig. 5**). Bearings with a flanged outer ring are relatively easy to locate axially in the housing. The housing bore is also easier and more cost-effective to manufacture, as shoulders are not required.

7

Fig. 5

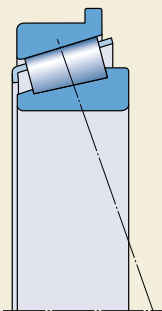

7 Tapered roller bearings

Matched bearings

Matched bearings (→ **fig. 6**) can be supplied for bearing arrangements where the load carrying capacity of a single bearing is inadequate, or where the shaft has to be located axially in both directions with a specific axial clearance or preload. The bearings and ring spacer(s) are matched in production and delivered as a set. When mounted, the radial load is evenly distributed between the bearings.

Depending on the requirements, matched bearings can be supplied in face-to-face, back-to-back, or tandem arrangements (→ **fig. 7**).

The matched bearings listed in this catalogue constitute the basic SKF assortment. Other matched bearings can be supplied on request.

Matched bearings arranged face-to-face

Matched bearings arranged face-to-face (→ **fig. 7**) have load lines that converge toward the bearing axis. Therefore, the arrangement can accommodate a limited amount of misalignment. Axial loads in both directions can be accommodated, but only by one bearing in each direction.

The bearing set is supplied with an intermediate outer ring spacer.

Matched bearings arranged back-to-back

Matched bearings arranged back-to-back (→ **fig. 7**) have load lines that diverge toward the bearing axis to provide a relatively stiff bearing arrangement that can also accommo-

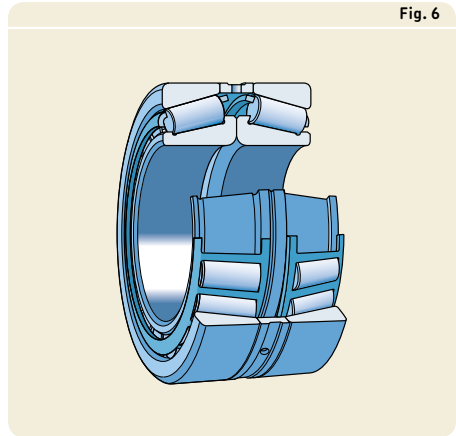

Fig. 6

date tilting moments. Axial loads in both directions can be accommodated, but only by one bearing in each direction.

The bearing set is supplied with intermediate inner and outer ring spacers.

Matched bearings arranged in tandem

Matched bearings arranged in tandem (→ **fig. 7**) have load lines that are parallel. Radial and axial loads are shared equally by the bearings. This arrangement is used when the load carrying capacity of a single bearing is inadequate. However, matched bearings arranged in tandem can accommodate axial loads in one direction only. If axial loads act in both directions, a third bearing, adjusted against the tandem pair, must be added.

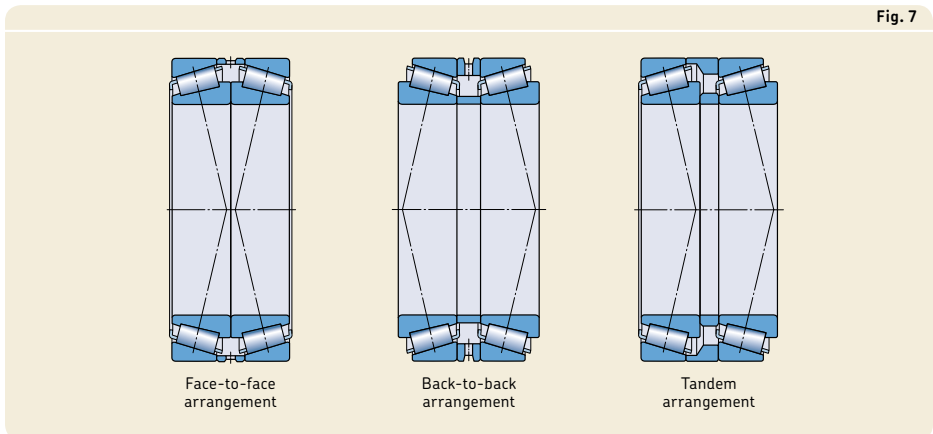

Fig. 7

Face-to-face arrangement

Back-to-back arrangement

Tandem arrangement

The bearing set is supplied with intermediate inner and outer ring spacers.

Cages

SKF tapered roller bearings are fitted with stamped steel cages as standard. Bearings with polymer cages are available on request (→ **table 1**).

The lubricants generally used for rolling bearings do not have a detrimental effect on cage properties. However, some synthetic oils and greases with a synthetic oil base and lubricants containing a high proportion of EP additives, when used at high temperatures, can have a detrimental effect on polyamide cages. For additional information about the suitability of cages, refer to *Cages* (→ **page 37**) and *Cage materials* (→ **page 152**).

Table 1

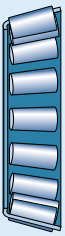
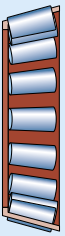
Cages for tapered roller bearings			
			
Cage type	Window-type, roller centred		
Material	Stamped steel	PA66, glass fibre reinforced	PEEK, glass fibre reinforced
Suffix	– J1, J2 or J3	TN9	TNH

Performance classes

SKF Explorer bearings

In response to the ever-demanding performance requirements of modern machinery, SKF developed the SKF Explorer performance class of rolling bearings.

SKF Explorer tapered roller bearings realized this substantial improvement in performance by optimizing the internal geometry and surface finish of all contact surfaces, combining the extremely clean and homogenous steel with a unique heat treatment, optimizing the roller end / flange contact area and cage and improving the roller profile and the quality and dimensional consistency of the rollers.

These improvements provide the following benefits:

- higher load carrying capacity
- improved wear-resistance
- reduced noise and vibration levels
- less frictional heat
- significantly extended bearing service life

SKF Explorer bearings reduce environmental impact by enabling downsizing and reducing both lubricant and energy use. Just as importantly, SKF Explorer bearings can reduce the need for maintenance and contribute to increased productivity.

SKF Explorer bearings are shown with an asterisk in the product tables. The bearings retain the designation of earlier standard bearings. However, each bearing and its box are marked with the name "SKF Explorer".

Other standard SKF tapered roller bearings can be manufactured in the SKF Explorer performance class on request. These bearings are identified by the designation suffix PEX.

SKF Energy Efficient (E2) bearings

To meet the ever-increasing demand to reduce friction and energy use, SKF has developed the SKF Energy Efficient (E2) performance class for rolling bearings. SKF E2 tapered roller bearings are characterized by a frictional moment in the bearing that is at least 30% lower when compared to a same-sized standard SKF bearing.

The bearings realized this substantial reduction of the frictional moment mainly by optimizing the internal geometry, number of rollers, surface finish and redesigning the cage.

Reduced operating temperatures improve lubrication conditions and enable extended lubrication intervals or higher speeds. The lower mass of the roller and cage assembly and reduced inertial forces in the bearing reduce the risk of skidding and smearing. Typical applications include wind energy transmissions, railway transmissions, ship transmissions and other heavy industrial transmissions.

Typically, SKF E2 tapered roller bearings are available on request. For additional information, contact the SKF application engineering service.

Bearing data / single row tapered roller bearings

	Metric series
Dimension standards	Boundary dimensions: ISO 355 Bearings with a J designation prefix: ANSI/ABMA Standard 19.1
Tolerances	Normal, improved running accuracy for bearings with a CL7C designation suffix Check availability of reduced width tolerance to CLN Bearings with a J designation prefix: <ul style="list-style-type: none"> • CLN Bearings with $D > 420$ mm: <ul style="list-style-type: none"> • Normal dimensional accuracy • P6 running accuracy
For additional information (→ page 132)	Values: ISO 492 (→ tables 6 and 7, pages 140 and 141) P6 values: DIN 620-3:1964 (withdrawn in 1988)
	The inner rings with roller and cage assembly and outer rings of SKF single row tapered roller bearings with the same basic ...
Internal clearance For additional information (→ page 149)	Obtained after mounting, depending on adjustment ...
Preload For additional information (→ page 214)	Obtained after mounting, depending on adjustment ...
Misalignment	TQ-line bearings (designation suffix Q), SKF Explorer and SKF E2 bearings: ≈ 2 to 4 minutes of arc. If misalignment cannot be ...
	The permissible angular misalignment between the inner and outer rings depends on the size and internal design of the bearing, the radial internal clearance in operation and the forces and moments acting on the ...
Friction, starting torque, power loss	Frictional moment, starting torque and power loss can be calculated as specified under <i>Friction</i> (→ page 97), or ...
Defect frequencies	Defect frequencies can be calculated using the tools available ...

Inch series
Boundary dimensions: AFBMA Standard 19 (ANSI B3.19) ANSI/ABMA Standard 19.2 has replaced the above standard, but does not include dimensions.
Normal, improved running accuracy for bearings with a CL7C designation suffix Check availability CL3, CL0 or reduced width tolerance
Deviating width tolerances for cups and cones are identified by a designation suffix (→ table 2, page 809).
Values: ANSI/ABMA Standard 19.2 (→ table 9, page 143)
... designation are interchangeable. The tolerance for the total abutment width T of the bearing is not exceeded if the cups and cones are interchanged.
... against a second bearing.
... against a second bearing.
... avoided, SKF recommends not to use basic design bearings.
... bearing. As a result, only approximate values are listed here. Any misalignment increases bearing noise and reduces bearing service life.
... using the tools available online at skf.com/bearingcalculator .
... online at skf.com/bearingcalculator .

Bearing data / matched bearings

Dimension standards	Boundary dimensions: ISO 355 (individual bearing)
Tolerances For additional information (→ page 132)	Normal
	Values: ISO 492 (→ table 6, page 140) Total width tolerances: not standardized (→ table 3)
Internal clearance For additional information (→ page 149)	Standard: → table 4, page 810 Other clearances are identified by the designation suffix C. Values apply to unmounted bearing sets under measuring loads of:
	D ≤ 90 mm → 0,1 kN 90 < D ≤ 240 mm → 0,3 kN D > 240 mm → 0,5 kN
Misalignment	If misalignment cannot be avoided, SKF recommends using a face-to-face arrangement. Any misalignment increases bearing noise and reduces bearing service life.
Friction, starting torque, power loss	Frictional moment, starting torque and power loss can be calculated as specified under <i>Friction</i> (→ page 97), or using the tools available online at skf.com/bearingcalculator .
Defect frequencies	Defect frequencies can be calculated using the tools available online at skf.com/bearingcalculator .

Table 2

Deviating width tolerances of cups and cones for inch bearings

Designation suffix	Width tolerance ¹⁾	
	max.	min.
–	µm	
/1	+25	0
/1A	+38	+13
/-1	0	-25
/11	+25	-25
/15	+25	-102
/2	+51	0
/2B	+76	+25
/2C	+102	+51
/-2	0	-51
/22	+51	-51
/3	+76	0
/-3	0	-76
/4	+102	0

¹⁾ The total width tolerance for a complete bearing is equal to the sum of the tolerances for the cup and cone.

Table 3

Total width tolerances of matched metric single row tapered roller bearings

Bore diameter	Total width tolerance Δ_{TSD} of matched bearings in the series												
	329		320		330		331, 302, 322, 332		303, 323		313		
d over	incl.	Δ_{TSD} high	low	Δ_{TSD} high	low	Δ_{TSD} high	low	Δ_{TSD} high	low	Δ_{TSD} high	low	Δ_{TSD} high	low
mm		µm											
–	30	–	–	+550	+100	–	–	+550	+100	+600	+150	+500	+50
30	40	–	–	+550	+100	–	–	+600	+150	+600	+150	+550	+50
40	50	–	–	+600	+150	–	–	+600	+200	+600	+200	+550	+50
50	65	–	–	+600	+150	–	–	+600	+200	+650	+200	+550	+100
65	80	–	–	+600	+200	–	–	+650	+200	+700	+200	+600	+100
80	100	+750	-150	+650	-250	+800	-50	+700	-200	+700	-100	+600	-300
100	120	+750	-150	+700	-200	+800	-100	+700	-200	+750	-150	+600	-300
120	140	+1 100	-200	+1 000	-300	+1 100	-200	+1 000	-300	+1 100	-200	+950	-350
140	160	+1 150	-150	+1 050	-250	+1 100	-200	+1 050	-250	+1 150	-150	+950	-350
160	180	+1 150	-150	+1 100	-200	–	–	+1 100	-200	+1 150	-150	–	–
180	190	+1 150	-150	+1 100	-200	–	–	+1 100	-200	+1 200	-100	–	–
190	200	+1 150	-150	+1 100	-200	–	–	+1 100	-200	+1 200	-100	–	–
200	225	+1 200	-100	+1 150	-150	–	–	+1 150	-150	+1 250	-50	–	–
225	250	+1 200	-100	+1 200	-100	–	–	+1 200	-100	+1 300	0	–	–
250	280	+1 300	0	+1 250	-50	–	–	+1 250	-50	–	–	–	–
280	300	+1 400	+100	+1 300	0	–	–	+1 300	0	–	–	–	–
300	315	+1 400	+100	+1 350	+50	–	–	+1 350	+50	–	–	–	–
315	340	+1 500	-200	+1 450	-250	–	–	+1 450	+200	–	–	–	–

Δ_{TSD} designates the deviation of a single total abutment width of a matched bearing set from the nominal.

7 Tapered roller bearings

Table 4

Axial internal clearance of matched metric single row tapered roller bearings, arranged face-to-face or back-to-back

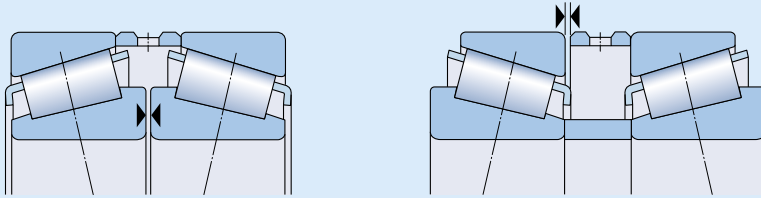

Bore diameter	Axial internal clearance of matched bearings in the series													
	329		320		330		331, 302, 322, 332		303, 323		313			
d	over	incl.	min.	max.	min.	max.	min.	max.	min.	max.	min.	max.	min.	max.
mm	μm													
–	30	–	–	80	120	–	–	100	140	130	170	60	100	
30	40	–	–	100	140	–	–	120	160	140	180	70	110	
40	50	–	–	120	160	180	220	140	180	160	200	80	120	
50	65	–	–	140	180	200	240	160	200	180	220	100	140	
65	80	–	–	160	200	250	290	180	220	200	260	110	170	
80	100	270	310	190	230	350	390	210	270	240	300	110	170	
100	120	270	330	220	280	340	400	220	280	280	340	130	190	
120	140	310	370	240	300	340	400	240	300	330	390	160	220	
140	160	370	430	270	330	340	400	270	330	370	430	180	240	
160	180	370	430	310	370	–	–	310	370	390	450	–	–	
180	190	370	430	340	400	–	–	340	400	440	500	–	–	
190	200	390	450	340	400	–	–	340	400	440	500	–	–	
200	225	440	500	390	450	–	–	390	450	490	550	–	–	
225	250	440	500	440	500	–	–	440	500	540	600	–	–	
250	280	540	600	490	550	–	–	490	550	–	–	–	–	
280	300	640	700	540	600	–	–	540	600	–	–	–	–	
300	340	640	700	590	650	–	–	590	650	–	–	–	–	

Loads

	Single row tapered roller bearings	Matched bearings
Minimum load	$F_{rm} = 0,02 C$	
	SKF Explorer and SKF E2 bearings $F_{rm} = 0,017 C$	
For additional information (→ page 86)	The weight of the components supported by the bearings, together with external forces, generally exceed the requisite minimum load. If this is not the case, the bearings must be subjected to an additional radial load or axial preload.	
Equivalent dynamic bearing load	$F_a/F_r \leq e \rightarrow P = F_r$ $F_a/F_r > e \rightarrow P = 0,4 F_r + Y F_a^{1)}$	Face-to-face or back-to-back arrangement: $F_a/F_r \leq e \rightarrow P = F_r + Y_1 F_a$ $F_a/F_r > e \rightarrow P = 0,67 F_r + Y_2 F_a$
For additional information (→ page 85)		Tandem arrangement ¹⁾ : $F_a/F_r \leq e \rightarrow P = F_r$ $F_a/F_r > e \rightarrow P = 0,4 F_r + Y F_a$
Equivalent static bearing load	$P_0 = 0,5 F_r + Y_0 F_a^{1)}$	Face-to-face or back-to-back arrangement: $P_0 = F_r + Y_0 F_a$
For additional information (→ page 88)		Tandem arrangement ¹⁾ : $P_0 = 0,5 F_r + Y_0 F_a$
	$P_0 < F_r \rightarrow P_0 = F_r$	
Symbols	<p>C = basic dynamic load rating [kN] (→ product tables)</p> <p>e = calculation factor (→ product tables)</p> <p>F_a = axial load [kN]</p> <p>F_r = radial load [kN]</p> <p>F_{rm} = minimum radial load [kN]</p> <p>P = equivalent dynamic bearing load [kN]</p> <p>P₀ = equivalent static bearing load [kN]</p> <p>Y, Y₀, Y₁, Y₂ = calculation factors (→ product tables)</p>	

¹⁾ When determining the axial load F_a, refer to *Calculating the axial load for bearings mounted singly or paired in tandem* (→ page 812).

7 Tapered roller bearings

Calculating the axial load for bearings mounted singly or paired in tandem

When a radial load is applied to a single row tapered roller bearing, the load is transmitted from one raceway to the other at an angle to the bearing axis and an internal axial load is induced. This must be considered when calculating the equivalent bearing loads for bearing arrangements consisting of two single bearings and/or bearing pairs arranged in tandem.

The necessary equations are provided in **table 5** for various bearing arrangements and load cases. The equations are only valid if the bearings are adjusted against each other to practically zero clearance, but without any preload. In the arrangements shown, bearing A is subjected to a radial load F_{rA} and bearing B to a radial load F_{rB} . Both F_{rA} and F_{rB} are always considered positive, even when they act in a direction opposite to what is shown in the figures. The radial loads act at the pressure centres of the bearings (\rightarrow distance a in the product tables).

K_a is the external axial force acting on the shaft or on the housing. Load cases 1c and 2c are also valid when $K_a = 0$. Values of the factor Y are listed in the product tables.

Table 5

Axial loading of bearing arrangements incorporating two single row tapered roller bearings and/or bearing pairs in tandem

Bearing arrangement	Load case	Axial loads	
<p>Back-to-back</p>	<p>Case 1a</p> $\frac{F_{rA}}{Y_A} \geq \frac{F_{rB}}{Y_B}$ $K_a \geq 0$	$F_{aA} = \frac{0,5 F_{rB}}{Y_A}$	$F_{aB} = F_{aA} + K_a$
	<p>Case 1b</p> $\frac{F_{rA}}{Y_A} < \frac{F_{rB}}{Y_B}$ $K_a \geq 0,5 \left(\frac{F_{rB}}{Y_B} - \frac{F_{rA}}{Y_A} \right)$	$F_{aA} = \frac{0,5 F_{rB}}{Y_A}$	$F_{aB} = F_{aA} + K_a$
<p>Face-to-face</p>	<p>Case 1c</p> $\frac{F_{rA}}{Y_A} < \frac{F_{rB}}{Y_B}$ $K_a < 0,5 \left(\frac{F_{rB}}{Y_B} - \frac{F_{rA}}{Y_A} \right)$	$F_{aA} = F_{aB} - K_a$	$F_{aB} = \frac{0,5 F_{rB}}{Y_B}$
<p>Back-to-back</p>	<p>Case 2a</p> $\frac{F_{rA}}{Y_A} \leq \frac{F_{rB}}{Y_B}$ $K_a \geq 0$	$F_{aB} = F_{aB} + K_a$	$F_{aA} = \frac{0,5 F_{rB}}{Y_A}$
	<p>Case 2b</p> $\frac{F_{rA}}{Y_A} > \frac{F_{rB}}{Y_B}$ $K_a \geq 0,5 \left(\frac{F_{rB}}{Y_B} - \frac{F_{rA}}{Y_A} \right)$	$F_{aA} = F_{aB} + K_a$	$F_{aB} = \frac{0,5 F_{rB}}{Y_B}$
<p>Face-to-face</p>	<p>Case 2c</p> $\frac{F_{rA}}{Y_A} > \frac{F_{rB}}{Y_B}$ $K_a < 0,5 \left(\frac{F_{rA}}{Y_A} - \frac{F_{rB}}{Y_B} \right)$	$F_{aA} = \frac{0,5 F_{rA}}{Y_A}$	$F_{aB} = F_{aA} - K_a$

7

7 Tapered roller bearings

Calculating the radial load acting on matched bearings

When matched tapered roller bearings, arranged face-to-face or back-to-back, are mounted together with a third bearing, the bearing arrangement is statically indeterminate. In these cases, the radial load F_r acting on the bearing pair must be calculated first.

Matched bearings arranged face-to-face

For matched bearings, where two bearings are arranged face-to-face (→ **fig. 8**), it can be assumed that the radial load acts at the geometric centre of the matched bearings, as the distance between the pressure centres of the two bearings is short when compared with the distance between the geometric centres of the set and the other bearing. In this case, it can be assumed that the bearing arrangement is statically determined.

Matched bearings arranged back-to-back

The distance a between the pressure centres of two matched bearings arranged back-to-back is significant when compared with the distance L between the geometric centres of the matched bearings and the other bearing (→ **fig. 9**). Therefore, it is necessary to calculate the magnitude of the load acting on the bearing pair and also the distance a_1 at which the load acts. The magnitude of the radial load can be obtained using

$$F_r = \frac{L_1}{L - a_1} K_r$$

where

F_r = radial load acting on a bearing pair [kN]

K_r = radial force acting on the shaft [kN]

L = distance between the geometric centres of the two bearing positions [mm]

L_1 = distance between the centre of bearing position I and the point of action of the force K_r [mm]

a = distance between the bearing pressure centres [mm]

a_1 = distance between the geometric centre of the matched bearings, and the point of action of the radial load F_r [mm]

The distance a_1 can be determined using **diagram 2**. The distance of the pressure centres a and the calculation factor Y_2 are listed in the product tables.

Fig. 8

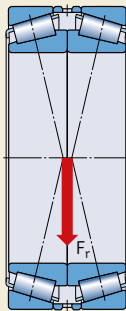
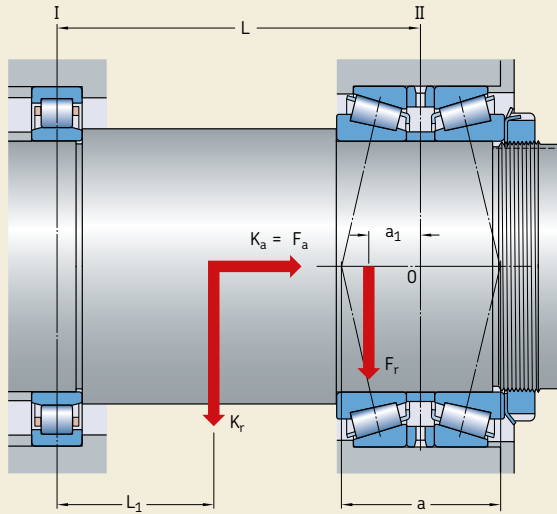
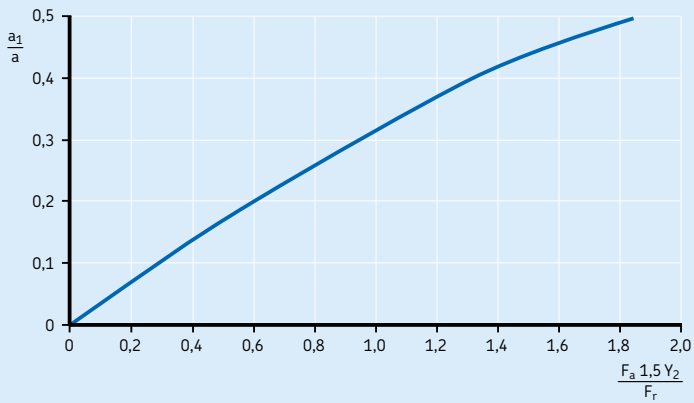

Fig. 9



7

Diagram 2



Temperature limits

The permissible operating temperature for tapered roller bearings can be limited by:

- the dimensional stability of the bearing rings and rollers
- the cage
- the lubricant

When temperatures outside the permissible range are expected, contact the SKF application engineering service.

Bearing rings and rollers

SKF tapered roller bearings undergo a special heat treatment. The bearings are heat stabilized up to:

- $D \leq 160 \text{ mm}$ → $120 \text{ }^\circ\text{C}$ ($250 \text{ }^\circ\text{F}$)
- $D > 160 \text{ mm}$ → $150 \text{ }^\circ\text{C}$ ($300 \text{ }^\circ\text{F}$)

Cages

Steel or PEEK cages can be used at the same operating temperatures as the bearing rings and rollers. For temperature limits of cages made of other polymer materials, refer to *Cage materials* (→ **page 152**).

Lubricants

Temperature limits for SKF greases are provided under *Lubrication* (→ **page 239**). When using lubricants not supplied by SKF, the temperature limits should be evaluated according to the SKF traffic light concept (→ **page 244**).

Permissible speed

The permissible speed can be estimated using the speed ratings listed in the product tables and applying the information provided under *Speeds* (→ **page 117**).

Design of bearing arrangements

Single row tapered roller bearings must either be used with a second bearing or as a matched pair (→ **fig. 10**). The bearings must be adjusted against each other until the requisite clearance or preload is obtained (→ *Bearing preload*, **page 214**). To maximize bearing performance and operational reliability, the appropriate clearance or preload must be selected and then applied during the mounting process. When the operating clearance in a bearing arrangement is too large, the load carrying capacity of both bearings cannot be fully utilized. Excessive preload increases friction, which increases the amount of frictional heat and reduces bearing service life.

Fits for inch bearings

In contrast to metric bearings, which are machined to a minus tolerance, inch bearings are machined to a plus tolerance (→ **table 9, page 143**). Therefore, the deviations for shaft and housing diameters for metric bearings are not applicable. Suitable fits for inch bearings can be obtained from the recommended fits for metric bearings. **Tables 6 and 7** (→ **pages 818 and 819**) provide the shaft and housing fits for inch tapered roller bearings that are valid for Normal tolerance bearings in typical applications.

Fits for matched bearings

The axial internal clearance of matched bearings arranged face-to-face or back-to-back (→ table 4, page 810) provides an appropriate operating clearance when the bearings are mounted on shafts machined to:

- $d \leq 140 \text{ mm}$ → m5[Ⓔ]
- $140 \text{ mm} < d \leq 200 \text{ mm}$ → n6[Ⓔ]
- $d > 200 \text{ mm}$ → p6[Ⓔ]

These shaft seat tolerance classes are recommended for normal to heavy rotating loads on the inner ring. If tighter fits are selected, be sure that the bearings are not “clamped” and that they are able to rotate freely. For additional information about shaft tolerances, contact the SKF application engineering service.

For stationary outer ring loads, the recommended housing bore tolerance class is J6[Ⓔ] or H7[Ⓔ].

7

Adjustment procedure

When adjusting tapered roller bearings against each other, the bearings must be rotated so that the rollers assume their correct position, i.e. the large end face of the rollers must be in contact with the guide flange.

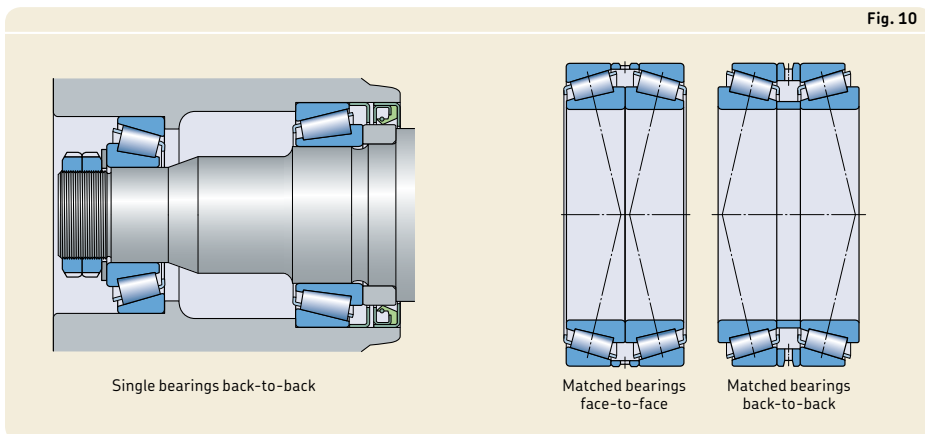

7 Tapered roller bearings

Table 6

Shaft diameter deviations for inch bearings

Nominal diameter Shaft seat Bearing bore over incl.		Deviations for fits with clearance/interference according to											
		f6(E)		g6(E)		h6(E)		j6(E)		js6(E)		k6(E)	
		high	low	high	low	high	low	high	low	high	low	high	low
mm		µm											
10	18	-	-	+2	-4	+8	+2	+16	+10	+14	+7	+20	+14
18	30	-	-	+3	-7	+10	0	+19	+9	+17	+6	+25	+15
30	50	-	-	+3	-12	+12	-3	+23	+8	+20	+5	+30	+15
50	76,2	-	-	+5	-16	+15	-6	+27	+6	+25	+3	+36	+15
80	120	-	-	+8	-9	+20	+3	+33	+16	+31	+14	-	-
120	180	-	-	+11	-14	+25	0	+39	+14	+38	+12	-	-
180	250	-	-	+15	-19	+30	-4	+46	+12	+45	+10	-	-
250	304,8	-	-	+18	-24	+35	-7	-	-	+51	+9	-	-
315	400	-22	-47	+22	-3	+40	+15	-	-	+58	+33	-	-
400	500	-23	-57	+25	-9	+45	+11	-	-	+65	+31	-	-
500	609,6	-26	-69	+28	-15	+50	+7	-	-	+72	+29	-	-
630	800	-5	-54	+51	+2	+75	+26	-	-	+100	+51	-	-
800	914,4	-14	-66	+74	-6	+100	+20	-	-	+128	+48	-	-

Nominal diameter Shaft seat Bearing bore over incl.		Deviations for fits with clearance/interference according to											
		m6(E)		n6(E)		p6(E)		r6(E)		r7(E)		s7(E) _{min} ± IT7/2	
		high	low	high	low	high	low	high	low	high	low	high	low
mm		µm											
10	18	-	-	-	-	-	-	-	-	-	-	-	-
18	30	-	-	-	-	-	-	-	-	-	-	-	-
30	50	+37	+22	+45	+30	-	-	-	-	-	-	-	-
50	76,2	+45	+24	+54	+33	-	-	-	-	-	-	-	-
80	120	+55	+38	+65	+48	+79	+62	-	-	-	-	-	-
120	180	+65	+40	+77	+52	+93	+68	-	-	-	-	-	-
180	200	-	-	+90	+56	+109	+75	+136	+102	-	-	-	-
200	225	-	-	+90	+56	+109	+75	+139	+105	-	-	-	-
225	250	-	-	+90	+56	+109	+75	+143	+109	-	-	-	-
250	280	-	-	-	-	+123	+81	+161	+119	-	-	-	-
280	304,8	-	-	-	-	+123	+81	+165	+123	-	-	-	-
315	355	-	-	-	-	+138	+113	+184	+159	-	-	-	-
355	400	-	-	-	-	+138	+113	+190	+165	-	-	-	-
400	450	-	-	-	-	-	-	+211	+177	-	-	-	-
450	500	-	-	-	-	-	-	+217	+183	-	-	-	-
500	560	-	-	-	-	-	-	-	-	+270	+201	+365	+296
560	609,6	-	-	-	-	-	-	-	-	+275	+206	+395	+326
630	710	-	-	-	-	-	-	-	-	+330	+251	+455	+376
710	800	-	-	-	-	-	-	-	-	+340	+281	+495	+416
800	900	-	-	-	-	-	-	-	-	+400	+286	+575	+461
900	914,4	-	-	-	-	-	-	-	-	+410	+296	+615	+501

For nominal diameter ranges not listed or higher requirements on accuracy, contact the SKF application engineering service.

Table 7

Housing bore diameter deviations for inch bearings

Nominal diameter Housing bore seat Bearing outside diameter over incl.		Deviations for fits with clearance/interference according to									
		F7 [Ⓔ]		G7 [Ⓔ]		H7 [Ⓔ]		H8 [Ⓔ]		J7 [Ⓔ]	
		high	low	high	low	high	low	high	low	high	low
mm		μm									
30	50	-	-	-	-	+36	+25	+50	+25	+25	+14
50	80	-	-	-	-	+43	+25	+59	+25	+31	+13
80	120	-	-	-	-	+50	+25	+69	+25	+37	+12
120	150	-	-	-	-	+58	+25	+81	+25	+44	+11
150	180	-	-	-	-	+65	+25	+88	+25	+51	+11
180	250	-	-	-	-	+76	+25	+102	+25	+60	+9
250	304,8	-	-	+104	+42	+87	+25	+116	+25	+71	+9
304,8	315	-	-	+104	+68	+87	+51	+116	+51	+71	+35
315	400	-	-	+115	+69	+97	+51	+129	+51	+79	+33
400	500	-	-	+128	+71	+108	+51	+142	+51	+88	+31
500	609,6	+196	+127	+142	+73	+120	+51	+160	+51	-	-
609,6	630	+196	+152	+142	+98	+120	+76	+160	+76	-	-
630	800	+235	+156	+179	+100	+155	+76	+200	+76	-	-
800	914,4	+276	+162	+216	+102	+190	+76	+240	+76	-	-
914,4	1 000	+276	+188	+216	+128	+190	+102	+240	+102	-	-
1 000	1 219,2	+328	+200	+258	+130	+230	+102	+290	+102	-	-

Nominal diameter Housing bore seat Bearing outside diameter over incl.		Deviations for fits with clearance/interference according to							
		K7 [Ⓔ]		M7 [Ⓔ]		N7 [Ⓔ]		P7 [Ⓔ]	
		high	low	high	low	high	low	high	low
mm		μm							
30	50	+18	+7	+11	0	+3	-8	-6	-17
50	80	+22	+4	+13	-5	+4	-14	-8	-26
80	120	+25	0	+15	-10	+5	-20	-9	-34
120	150	+30	-3	+18	-15	+6	-27	-10	-43
150	180	+37	-3	+25	-15	+13	-27	-3	-43
180	250	+43	-8	+30	-21	+16	-35	-3	-54
250	304,8	+51	-11	+35	-27	+21	-41	-1	-63
304,8	315	+51	+15	+35	-1	+21	-15	-1	-37
315	400	+57	+11	+40	-6	+24	-22	-1	-47
400	500	+63	+6	+45	-12	+28	-29	0	-57
500	609,6	+50	-19	+24	-45	+6	-63	-28	-97
609,6	630	+50	+6	+24	-20	+6	-38	-28	-72
630	800	+75	-4	+45	-34	+25	-54	-13	-92
800	914,4	+100	-14	+66	-48	+44	-70	0	-114
914,4	1 000	+100	+12	+66	-22	+44	-44	0	-88
1 000	1 219,2	+125	-3	+85	-43	+59	-69	+5	-123

For higher requirements on accuracy, contact the SKF application engineering service.

Bearing designations

Metric bearings

The designations of metric tapered roller bearings follow one of the following principles:

- The series designations in accordance with ISO 355 consist of a digit and two letters. The digit represents the contact angle. The two letters represent the diameter and width series, respectively. This is followed by a three-digit bore diameter d [mm]. The basic designations of SKF tapered roller bearings start with the letter T, e.g. T2ED 045.
- Designations established prior to 1977 are based on the system shown under *Basic designations*, e.g. 32206 (→ **diagram 2, page 43**).
- Metric bearings with the designation prefix J follow the ABMA designation system which is used for inch bearings (→ ANSI/ABMA Standard 19.2).

Inch bearings

Inch tapered roller bearing designations are in accordance with ANSI/ABMA 19.2.

All inch bearings within a series use the same roller and cage assembly but the inner and outer rings can have different sizes and designs.

Any inner ring with roller and cage assembly (cone) can be assembled with any outer ring (cup) belonging to the same bearing series. For this reason, the cup and cone have individual designations and can be supplied separately (→ **fig. 11**). The designations of cups and cones as well as the series consist of a three- to six-digit number which may be prefixed to characterize a bearing series from extra-light to extra-heavy.

The complete bearing designation consists of the cone designation followed by that of the cup. The two designations are separated by an oblique stroke. To shorten the complete bearing designations, abbreviations are used (→ **table 8**).



Fig. 11

7

Table 8

Examples of inch tapered roller bearing designations

Complete bearing	Cone	Cup	Series
LM 11749/710/Q ¹⁾	LM 11749/Q	LM 11710/Q	LM 11700
JL 26749 F/710 ¹⁾	JL 26749 F	JL 26710	JL 26700
HM 89449/2/410/2/QCL7C ¹⁾	HM 89449/2/QCL7C	HM 89410/2/QCL7C	HM 89400
H 913842/810/CL7C ¹⁾	H 913842/CL7C	H 913810/CL7C	H 913800
4580/2/4535/2/Q ²⁾	4580/2/Q	4535/2/Q	4500
9285/9220/CL7C ²⁾	9285/CL7C	9220/CL7C	9200

¹⁾ Complete bearing designation abbreviated (latest ABMA designations)

²⁾ Complete bearing designation not abbreviated (earlier ABMA designations)

Designation system

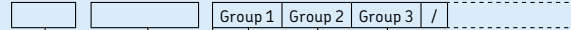

Prefixes

- E2.** SKF Energy Efficient bearing
- J** Metric bearing following the ABMA designation system (ANSI/ABMA Standard 19.2)
- T** Metric bearing in accordance with ISO 355

Basic designation

Refer to *Bearing designations* (→ page 820)

Suffixes

Group 1: Internal design

- B** Steep contact angle

Group 2: External design (seals, snap ring groove etc.)

- R** Flanged outer ring
- T..** A number immediately following the T identifies the total width of matched bearings, arranged back-to-back or in tandem.
- X** Boundary dimensions changed to conform to ISO

Group 3: Cage design

- J..** Stamped steel cage, roller centred. A number following the J indicates a different cage design.
- TN9** Glass fibre reinforced PA66 cage, roller centred
- TNH** Glass fibre reinforced PEEK cage, roller centred

Group 4.1: Materials, heat treatment

- HA1** Case-hardened inner and outer rings
- HA3** Case-hardened inner ring
- HN1** Inner and outer rings with special surface heat treatment
- HN3** Inner ring with special surface heat treatment

Group 4					
4.1	4.2	4.3	4.4	4.5	4.6

Group 4.6: Other variants

- CL7A** Pinion bearing, superseded by CL7C
- CL7C** High-performance design
- CLN** Reduced tolerances for ring widths and total (abutment) width in accordance with ISO tolerance class 6X
- PEX** SKF Explorer bearing on customer request
- Q** Optimized contact geometry and surface finish
- V001** CL7C and /2
- VA321** Optimized internal design
- VA606** Crowned raceway on the outer ring, logarithmic profile on the inner ring and special heat treatment
- VA607** Same as VA606, but other outside diameter tolerance
- VC027** Modified internal geometry for increased permissible misalignment
- VC068** Increased running accuracy and special heat treatment
- VQ051** Modified internal geometry for increased permissible misalignment
- VQ267** Reduced inner ring width tolerance to $\pm 0,025$ mm
- VQ495** CL7C with reduced or shifted tolerance range for the outside diameter
- VQ506** Reduced inner ring width tolerance
- VQ507** CL7C with reduced or shifted tolerance range for the outside diameter
- VQ523** CL7C with reduced inner ring width tolerance and reduced or shifted tolerance range for the outside diameter
- VQ601** Accuracy to ABMA tolerance class 0 for inch bearings
- VB022** Chamfer dimension of large outer ring side face 0,3 mm
- VB026** Chamfer dimension of large inner ring side face 3 mm
- VB061** Chamfer dimension of large inner ring side face 8 mm
- VB134** Chamfer dimension of large inner ring side face 1 mm
- VB406** Chamfer dimension of large inner ring side face 3 mm and of large outer ring side face 2 mm
- VB481** Chamfer dimension of large inner ring side face 8,5 mm
- VE174** One locating slot in the large side face of the outer ring, improved running accuracy

Group 4.5: Lubrication

Group 4.4: Stabilization

Group 4.3: Bearing sets, matched bearings

- DB..** Two bearings matched for mounting back-to-back. A number immediately following the DB identifies the design of the ring spacers.
- DF..** Two bearings matched for mounting face-to-face. A number immediately following the DF identifies the design of the ring spacer.
- DT..** Two bearings matched for mounting in tandem. A number immediately following the DT identifies the design of the ring spacers.

Group 4.2: Accuracy, clearance, preload, quiet running

- /1
 - /-1
 - to
 - /-3
 - /4
 - C...
- } Deviating width tolerances of cups and cones for inch bearings, (→ table 2, page 809)
- CL0** Accuracy to ABMA tolerance class 0 for inch bearings
 - CL00** Accuracy to ABMA tolerance class 00 for inch bearings
 - P5** Dimensional and running accuracy to P5 tolerance class
 - U..** U combined with a one- or two-digit number identifies reduced total width tolerance, e.g.:
 - U2 ... +0,05/0 mm
 - U4 ... +0,10/0 mm
 - W** Modified ring width tolerance to +0,05/0 mm

7.1 Metric single row tapered roller bearings d 15 – 32 mm

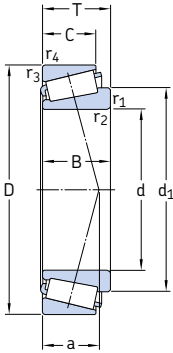

Principal dimensions			Basic load ratings		Fatigue load limit P_u	Speed ratings		Mass	Designation	Dimension series to ISO 355 (ABMA)
d	D	T	dynamic C	static C_0		Reference speed	Limiting speed			
mm			kN		kN	r/min		kg	-	-
15	42	14,25	22,4	20	2,08	13 000	18 000	0,094	30302 J2	2FB
17	40	13,25	19	18,6	1,83	13 000	18 000	0,079	30203 J2	2DB
	47	15,25	28,1	25	2,7	12 000	16 000	0,13	30303 J2	2FB
	47	20,25	34,7	33,5	3,65	11 000	16 000	0,17	32303 J2/Q	2FD
20	42	15	24,2	27	2,65	12 000	16 000	0,098	32004 X/Q	3CC
	47	15,25	27,5	28	3	11 000	15 000	0,12	30204 J2/Q	2DB
	52	16,25	34,1	32,5	3,55	11 000	14 000	0,17	30304 J2/Q	2FB
	52	22,25	44	45,5	5	10 000	14 000	0,23	32304 J2/Q	2FD
22	44	15	25,1	29	2,85	11 000	15 000	0,1	320/22 X	3CC
	52	16,25	30,8	33,5	3,45	10 000	13 000	0,15	30205 J2/Q	3CC
25	52	19,25	35,8	44	4,65	9 500	13 000	0,19	32205 BJ2/Q	5DC
	52	22	47,3	56	6	9 000	13 000	0,22	33205/Q	2CE
	62	18,25	44,6	43	4,75	9 000	12 000	0,26	30305 J2/Q	2FB
	62	18,25	38	40	4,4	7 500	11 000	0,27	31305 J2	7FB
	62	25,25	60,5	63	7,1	8 000	12 000	0,36	32305 J2	2FD
28	52	16	31,9	38	4	9 500	13 000	0,14	320/28 X/Q	4CC
	58	17,25	38	41,5	4,4	9 000	12 000	0,2	302/28 J2	3DC
	58	20,25	41,8	50	5,5	8 500	12 000	0,25	322/28 BJ2/Q	5DD
30	55	17	35,8	44	4,55	9 000	12 000	0,17	32006 X/Q	4CC
	62	17,25	40,2	44	4,8	8 500	11 000	0,23	30206 J2/Q	3DB
	62	21,25	49,5	58,5	6,55	8 000	11 000	0,3	32206 BJ2/QCL7CVA606	5DC
	62	21,25	50,1	57	6,3	8 500	11 000	0,29	32206 J2/Q	3DC
	62	25	64,4	76,5	8,5	7 500	11 000	0,35	33206/Q	2DE
	72	20,75	56,1	56	6,4	7 500	10 000	0,38	30306 J2/Q	2FB
	72	20,75	47,3	50	5,7	6 700	9 500	0,39	31306 J2/Q	7FB
72	28,75	76,5	85	9,65	7 000	10 000	0,55	32306 J2/Q	2FD	
32	53	14,5	27	35,5	3,65	9 000	13 000	0,11	JL 26749 F/710	(L 26700)
	58	17	36,9	46,5	4,8	8 500	11 000	0,19	320/32 X/Q	4CC

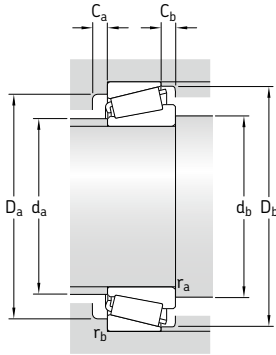

Dimensions							Abutment and fillet dimensions								Calculation factors				
d	d ₁	B	C	r _{1,2}	r _{3,4}	a	d _a	d _b	D _a	D _a	D _b	C _a	C _b	r _a	r _b	e	Y	Y ₀	
mm	~			min.	min.		mm										-		
15	27,3	13	11	1	1	9	22	21	36	36	38	2	3	1	1	0,28	2,1	1,1	
17	29	12	11	1	1	10	23	23	34	34	37	2	2	1	1	0,35	1,7	0,9	
	30,5	14	12	1	1	10	25	23	40	41	42	2	3	1	1	0,28	2,1	1,1	
	30,7	19	16	1	1	12	24	23	39	41	43	3	4	1	1	0,28	2,1	1,1	
20	32,1	15	12	0,6	0,6	10	25	25	36	37	39	3	3	0,6	0,6	0,37	1,6	0,9	
	33,7	14	12	1	1	11	27	26	40	41	43	2	3	1	1	0,35	1,7	0,9	
	34,4	15	13	1,5	1,5	11	28	27	44	45	47	2	3	1,5	1,5	0,3	2	1,1	
	34,6	21	18	1,5	1,5	14	27	27	43	45	47	3	4	1,5	1,5	0,3	2	1,1	
22	34,1	15	11,5	0,6	0,6	11	27	27	38	39	41	3	3,5	0,6	0,6	0,4	1,5	0,8	
25	37,5	15	11,5	0,6	0,6	11	30	30	40	42	44	3	3,5	0,6	0,6	0,43	1,4	0,8	
	38	15	13	1	1	12	31	31	44	46	48	2	3	1	1	0,37	1,6	0,9	
	41,5	18	15	1	1	16	30	31	41	46	49	3	4	1	1	0,57	1,05	0,6	
	38,7	22	18	1	1	14	30	31	43	46	49	4	4	1	1	0,35	1,7	0,9	
	41,5	17	15	1,5	1,5	13	34	32	54	55	57	2	3	1,5	1,5	0,3	2	1,1	
45,8	17	13	1,5	1,5	20	34	32	47	55	59	3	5	1,5	1,5	0,83	0,72	0,4		
41,7	24	20	1,5	1,5	15	33	32	53	55	57	3	5	1,5	1,5	0,3	2	1,1		
28	41,3	16	12	1	1	12	33	34	45	46	49	3	4	1	1	0,43	1,4	0,8	
	42	16	14	1	1	13	35	34	50	52	54	2	3	1	1	0,37	1,6	0,9	
	43,9	19	16	1	1	17	33	34	46	52	55	3	4	1	1	0,57	1,05	0,6	
30	43,6	17	13	1	1	13	35	36	48	49	52	3	4	1	1	0,43	1,4	0,8	
	45,3	16	14	1	1	14	37	36	53	56	57	2	3	1	1	0,37	1,6	0,9	
	48,2	20	17	1	1	18	36	36	50	56	60	3	4	1	1	0,57	1,05	0,6	
	45,2	20	17	1	1	15	37	36	52	56	59	3	4	1	1	0,37	1,6	0,9	
	45,8	25	19,5	1	1	16	36	36	53	56	59	5	5,5	1	1	0,35	1,7	0,9	
	48,4	19	16	1,5	1,5	15	40	37	62	65	66	3	4,5	1,5	1,5	0,31	1,9	1,1	
52,7	19	14	1,5	1,5	22	40	37	55	65	68	3	6,5	1,5	1,5	0,83	0,72	0,4		
48,7	27	23	1,5	1,5	18	39	37	59	65	66	4	5,5	1,5	1,5	0,31	1,9	1,1		
32	43,4	15	11,5	3,6	1,3	11	38	43	47	47	50	2	3	3	1,3	0,33	1,8	1	
	46,2	17	13	1	1	14	38	38	50	52	55	3	4	1	1	0,46	1,3	0,7	

7.1 Metric single row tapered roller bearings d 35 – 45 mm

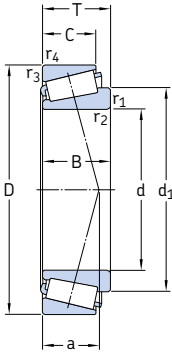

Principal dimensions			Basic load ratings		Fatigue load limit	Speed ratings		Mass	Designation	Dimension series to ISO 355 (ABMA)	
d	D	T	dynamic C	static C ₀	P _u	Reference speed	Limiting speed				
mm			kN		kN	r/min		kg	-	-	
35	62	18	37,4	49	5,2	8 000	11 000	0,23	32007 J2/Q	4CC	
	62	18	42,9	54	5,85	8 000	10 000	0,23	32007 X/Q	4CC	
	72	18,25	51,2	56	6,1	7 000	9 500	0,33	30207 J2/Q	3DB	
	72	24,25	66	78	8,5	7 000	9 500	0,44	32207 J2/Q	3DC	
	72	28	84,2	106	11,8	6 300	9 500	0,53	33207/Q	2DE	
	80	22,75	72,1	73,5	8,3	6 700	9 000	0,51	30307 J2/Q	2FB	
	80	22,75	61,6	67	7,8	6 000	8 500	0,52	31307 J2/Q	7FB	
	80	32,75	93,5	114	12,9	6 000	8 500	0,8	32307 BJ2/Q	5FE	
	80	32,75	95,2	106	12,2	6 300	9 000	0,75	32307 J2/Q	2FE	
	37	80	32,75	93,5	114	12,9	6 300	9 500	0,77	32307/37 BJ2/Q	5EE
	38	63	17	36,9	52	5,4	7 500	11 000	0,21	JL 69349 A/310/Q	3CC
		63	17	36,9	52	5,4	7 500	11 000	0,2	JL 69349/310/Q	3CC
68		19	52,8	71	7,65	7 000	10 000	0,3	32008/38 X/Q	3CC	
40	68	19	52,8	71	7,65	7 000	9 500	0,28	32008 X/Q	3CD	
	75	26	79,2	104	11,4	6 700	9 000	0,5	33108/Q	2CE	
	80	19,75	61,6	68	7,65	6 300	8 500	0,42	30208 J2/Q	3DB	
	80	24,75	74,8	86,5	9,8	6 300	8 500	0,53	32208 J2/Q	3DC	
	80	32	105	132	15	5 600	8 500	0,73	33208/QCL7C	2DE	
	85	33	121	150	17,3	6 000	9 000	0,9	T2EE 040/QVB134	2EE	
	90	25,25	85,8	95	10,8	6 000	8 000	0,73	30308 J2/Q	2FB	
	90	25,25	85	81,5	9,5	5 600	7 500	0,72	* 31308 J2/QCL7C	7FB	
90	35,25	117	140	16	5 300	8 000	1,05	32308 J2/Q	2FD		
45	75	20	58,3	80	8,8	6 300	8 500	0,34	32009 X/Q	3CC	
	80	26	96,5	114	12,9	6 700	8 000	0,55	* 33109/Q	3CE	
	85	20,75	66	76,5	8,65	6 000	8 000	0,47	30209 J2/Q	3DB	
	85	24,75	91,5	98	11	6 300	8 000	0,58	* 32209 J2/Q	3DC	
	85	32	108	143	16,3	5 300	7 500	0,79	33209/Q	3DE	
	95	29	89,7	112	12,7	4 800	7 000	0,93	T7FC 045/HN3QCL7C	7FC	
	95	36	147	186	20,8	5 300	8 000	1,2	T2ED 045	2FD	
	100	27,25	108	120	14,3	5 300	7 000	0,97	30309 J2/Q	2FB	
	100	27,25	106	102	12,5	5 000	6 700	0,95	* 31309 J2/QCL7C	7FB	
	100	38,25	134	176	20	4 800	6 700	1,45	32309 BJ2/QCL7C	5FD	
100	38,25	140	170	20,4	4 800	7 000	1,4	32309 J2/Q	2FD		

* SKF Explorer bearing

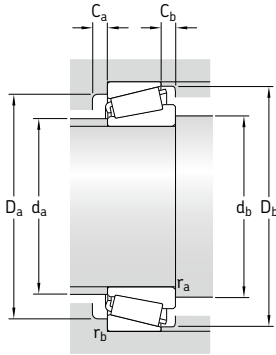

Dimensions

Abutment and fillet dimensions

Calculation factors

d	d ₁	B	C	r _{1,2}	r _{3,4}	a	d _a	d _b	D _a	D _a	D _b	C _a	C _b	r _a	r _b	e	Y	Y ₀
mm	~			min.	min.		max.	min.	min.	max.	min.	min.	min.	max.	max.	-		
35	49,5	17	15	1	1	16	41	41	53	56	59	2	3	1	1	0,44	1,35	0,8
	49,6	18	14	1	1	15	40	41	54	56	59	4	4	1	1	0,46	1,3	0,7
	51,9	17	15	1,5	1,5	15	44	42	62	65	67	3	3	1,5	1,5	0,37	1,6	0,9
	52,4	23	19	1,5	1,5	17	43	42	61	65	67	3	3	1,5	1,5	0,37	1,6	0,9
	53,4	28	22	1,5	1,5	18	42	42	61	65	68	5	6	1,5	1,5	0,35	1,7	0,9
	54,5	21	18	2	1,5	16	45	44	70	71	74	3	4,5	2	1,5	0,31	1,9	1,1
	59,6	21	15	2	1,5	25	44	44	62	71	76	4	7,5	2	1,5	0,83	0,72	0,4
	59,3	31	25	2	1,5	24	42	44	61	71	76	4	7,5	2	1,5	0,54	1,1	0,6
	54,8	31	25	2	1,5	20	44	44	66	71	74	4	7,5	2	1,5	0,31	1,9	1,1
	37	59,3	31	25	2	1,5	24	44	44	66	71	74	4	7,5	2	1,5	0,54	1,1
38	52,2	17	13,5	1,3	1,3	14	44	44	55	56,5	60	3	3,5	1,3	1,3	0,43	1,4	0,8
	52,2	17	13,5	3,6	1,3	14	44	50	55	56,5	60	3	3,5	3,4	1,3	0,43	1,4	0,8
	54,7	19	14,5	1	1	15	46	46	60	62	65	4	4,5	1	1	0,37	1,6	0,9
40	54,7	19	14,5	1	1	15	46	46	60	62	65	4	4,5	1	1	0,37	1,6	0,9
	57,5	26	20,5	1,5	1,5	18	47	47	65	68	71	4	5,5	1,5	1,5	0,35	1,7	0,9
	57,5	18	16	1,5	1,5	16	49	47	69	73	74	3	3,5	1,5	1,5	0,37	1,6	0,9
	58,4	23	19	1,5	1,5	19	48	47	68	73	75	3	5,5	1,5	1,5	0,37	1,6	0,9
	59,7	32	25	1,5	1,5	21	47	47	67	73	76	5	7	1,5	1,5	0,35	1,7	0,9
	61,2	32,5	28	1	2	22	48	50	70	75	80	5	5	1	2	0,35	1,7	0,9
	62,5	23	20	2	1,5	19	52	49	77	81	82	3	5	2	1,5	0,35	1,7	0,9
	67,1	23	17	2	1,5	28	51	49	71	81	86	3	8	2	1,5	0,83	0,72	0,4
62,9	33	27	2	1,5	23	50	49	73	81	82	4	8	2	1,5	0,35	1,7	0,9	
45	60,7	20	15,5	1	1	16	51	51	67	69	72	4	4,5	1	1	0,4	1,5	0,8
	63	26	20,5	1,5	1,5	19	52	52	69	73	77	4	5,5	1,5	1,5	0,37	1,6	0,9
	63,1	19	16	1,5	1,5	18	54	52	74	78	80	3	4,5	1,5	1,5	0,4	1,5	0,8
	64,1	23	19	1,5	1,5	20	53	52	73	78	80	3	5,5	1,5	1,5	0,4	1,5	0,8
	65,3	32	25	1,5	1,5	22	52	52	72	78	81	5	7	1,5	1,5	0,4	1,5	0,8
	73,5	26,5	20	2,5	2,5	32	54	55	71	83	91	3	9	2,5	2,5	0,88	0,68	0,4
	68,7	35	30	2,5	2,5	23	55	56	80	83	89	6	6	2,5	2,5	0,33	1,8	1
	70,2	25	22	2	1,5	21	59	54	86	91	92	3	5	2	1,5	0,35	1,7	0,9
	74,7	25	18	2	1,5	31	56	54	79	91	95	4	9	2	1,5	0,83	0,72	0,4
	74,8	36	30	2	1,5	30	55	54	76	91	94	5	8	2	1,5	0,54	1,1	0,6
	71,1	36	30	2	1,5	25	56	54	82	91	93	4	8	2	1,5	0,35	1,7	0,9

7.1 Metric single row tapered roller bearings d 46 – 55 mm

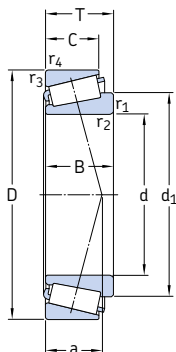

Principal dimensions			Basic load ratings		Fatigue load limit P_u	Speed ratings		Mass	Designation	Dimension series to ISO 355 (ABMA)
d	D	T	dynamic C	static C_0		Reference speed	Limiting speed			
mm			kN		kN	r/min		kg	-	-
46	75	18	50,1	71	7,65	6 300	9 500	0,3	LM 503349/310/QCL7C	(LM 503300)
50	80	20	60,5	88	9,65	6 000	8 000	0,38	32010 X/Q	3CC
	80	20	60,5	88	9,65	6 000	8 000	0,38	32010 X/QCL7CVB026	3CC
	80	24	69,3	102	11,4	6 000	8 000	0,45	33010/Q	2CE
	82	21,5	72,1	100	11	6 000	8 500	0,43	JLM 104948 AA/910 AA/Q	2CC
	85	26	85,8	122	13,4	5 600	7 500	0,58	33110/Q	3CE
	90	21,75	76,5	91,5	10,4	5 600	7 500	0,54	30210 J2/Q	3DB
	90	24,75	82,5	100	11,4	5 600	7 500	0,62	32210 J2/Q	3DC
	90	28	106	140	16	5 300	8 000	0,75	JM 205149/110 A/Q	(M 205100)
	90	28	106	140	16	5 300	8 000	0,75	JM 205149/110/Q	2DD
	90	32	114	160	18,3	5 000	7 000	0,86	33210/Q	3DE
	100	36	154	200	22,4	5 000	7 500	1,3	T2ED 050/Q	2ED
	105	32	108	137	16	4 300	6 300	1,25	T7FC 050/QCL7C	7FC
	110	29,25	143	140	16,6	5 300	6 300	1,25	* 30310 J2/Q	2FB
	110	29,25	122	120	14,3	4 500	6 000	1,2	* 31310 J2/QCL7C	7FB
	110	42,25	183	216	24,5	4 500	6 000	1,95	* 32310 BJ2/QCL7C	5FD
	110	42,25	172	212	24	4 300	6 300	1,85	32310 J2/Q	2FD
55	90	23	80,9	116	12,9	5 300	7 000	0,56	32011 X/Q	3CC
	90	27	104	137	15,3	5 600	7 000	0,66	* 33011/Q	2CE
	95	30	110	156	17,6	5 000	6 700	0,85	33111/Q	3CE
	100	22,75	104	106	12	5 300	6 700	0,7	* 30211 J2/Q	3DB
	100	26,75	106	129	15	5 000	6 700	0,84	32211 J2/Q	3DC
	100	35	138	190	21,6	4 500	6 300	1,15	33211/Q	3DE
	110	39	179	232	26	4 500	6 700	1,7	T2ED 055/QCLN	2FD
	115	34	125	163	19,3	4 000	5 600	1,6	T7FC 055/QCL7C	7FC
	120	31,5	166	163	19,3	4 800	5 600	1,55	* 30311 J2/Q	2FB
	120	31,5	121	137	16,6	3 800	5 600	1,55	31311 J2/QCL7C	7FB
	120	45,5	216	260	30	4 300	5 600	2,5	* 32311 BJ2/QCL7C	5FD
	120	45,5	198	250	28,5	4 000	5 600	2,35	32311 J2	2FD

* SKF Explorer bearing

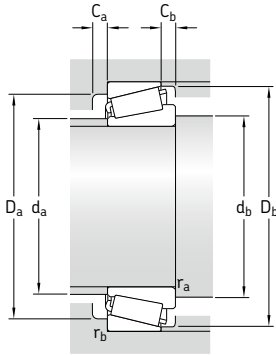

Dimensions

Abutment and fillet dimensions

Calculation factors

d	d ₁	B	C	r _{1,2}	r _{3,4}	a	d _a	d _b	D _a	D _a	D _b	C _a	C _b	r _a	r _b	e	Y	Y ₀
							mm							-				
46	61	18	14	2,3	1,6	16	53	55	67	67,5	71	2	4	2,3	1,5	0,4	1,5	0,8
50	65,9	20	15,5	3	1	18	56	56	72	74	77	4	4,5	1	1	0,43	1,4	0,8
	65,9	20	15,5	3	1	18	56	56	72	74	77	4	4,5	1	1	0,43	1,4	0,8
	65,3	24	19	1	1	17	56	56	72	74	76	4	5	1	1	0,31	1,9	1,1
	65,1	21,5	17	3,6	1,2	16	57	62	74	76	78	4	4,5	3,4	1,2	0,3	2	1,1
	68	26	20	1,5	1,5	20	56	57	74	76	78	4	6	1,5	1,5	0,4	1,5	0,8
	68	20	17	1,5	1,5	19	58	57	79	83	85	3	4,5	1,5	1,5	0,43	1,4	0,8
	68,6	23	19	1,5	1,5	21	58	57	78	83	85	3	5,5	1,5	1,5	0,43	1,4	0,8
	68,8	28	23	3	2,5	20	58	64	78	85	85	5	5	2,5	0,8	0,33	1,8	1
	68,8	28	23	3	2,5	20	58	64	78	78	85	5	5	2,5	0,5	0,33	1,8	1
	70,8	32	24,5	1,5	1,5	23	57	57	77	83	87	5	7,5	1,5	1,5	0,4	1,5	0,8
	73,5	35	30	2,5	2,5	25	59	60	84	88	94	6	6	2,5	2,5	0,35	1,7	0,9
	81,3	29	22	3	3	36	60	62	78	91	100	4	10	2,5	2,5	0,88	0,68	0,4
77,2	27	23	2,5	2	23	65	60	95	100	102	4	6	2,5	2	0,35	1,7	0,9	
81,5	27	19	2,5	2	34	62	60	87	100	104	4	10	2,5	2	0,83	0,72	0,4	
83,1	40	33	2,5	2	34	60	60	83	100	103	5	9	2,5	2	0,54	1,1	0,6	
77,8	40	33	2,5	2	27	62	60	90	100	102	5	9	2,5	2	0,35	1,7	0,9	
55	73,3	23	17,5	1,5	1,5	19	63	62	81	83	86	4	5,5	1,5	1,5	0,4	1,5	0,8
	73,1	27	21	1,5	1,5	19	63	62	81	83	86	5	6	1,5	1,5	0,31	1,9	1,1
	75,1	30	23	1,5	1,5	22	62	62	83	88	91	5	7	1,5	1,5	0,37	1,6	0,9
	74,7	21	18	2	1,5	20	64	64	88	91	94	4	4,5	2	1,5	0,4	1,5	0,8
	75,3	25	21	2	1,5	22	63	64	87	91	95	4	5,5	2	1,5	0,4	1,5	0,8
	78,1	35	27	2	1,5	25	62	64	85	91	96	6	8	2	1,5	0,4	1,5	0,8
	80,9	39	32	2,5	2,5	27	66	65	93	99	104	7	7	2,5	2,5	0,35	1,7	0,9
	89,5	31	23,5	3	3	39	66	67	86	103	109	4	10,5	2,5	2,5	0,88	0,68	0,4
	84	29	25	2,5	2	24	71	65	104	110	111	4	6,5	2,5	2	0,35	1,7	0,9
	88,4	29	21	2,5	2	37	68	65	94	110	113	4	10,5	2,5	2	0,83	0,72	0,4
	90,5	43	35	2,5	2	36	65	65	91	110	112	5	10,5	2,5	2	0,54	1,1	0,6
	84,6	43	35	2,5	2	29	68	65	99	110	111	5	10,5	2,5	2	0,35	1,7	0,9

7.1 Metric single row tapered roller bearings d 60 – 70 mm

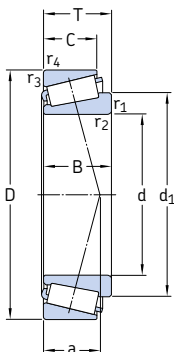

Principal dimensions			Basic load ratings		Fatigue load limit P_u	Speed ratings		Mass	Designation	Dimension series to ISO 355 (ABMA)
d	D	T	dynamic C	static C_0		Reference speed	Limiting speed			
mm			kN		kN	r/min		kg	–	–
60	95	23	95	122	13,4	5 300	6 700	0,59	* 32012 X/QCL7C	4CC
	95	27	106	143	16	5 300	6 700	0,7	* 33012/Q	2CE
	100	30	117	170	19,6	4 800	6 300	0,92	33112/Q	3CE
	110	23,75	112	114	13,2	5 000	6 000	0,88	* 30212 J2/Q	3EB
	110	29,75	125	160	18,6	4 500	6 000	1,15	32212 J2/Q	3EC
	110	38	168	236	26,5	4 000	6 000	1,55	33212/Q	3EE
	115	40	194	260	30	4 300	6 300	1,85	T2EE 060/Q	2EE
	125	37	154	204	24,5	3 600	5 300	2,05	T7FC 060/QCL7C	7FC
	130	33,5	168	196	23,6	4 000	5 300	1,95	30312 J2/Q	2FB
	130	33,5	145	166	20,4	3 600	5 300	1,9	31312 J2/QCL7C	7FB
	130	48,5	220	305	35,5	3 600	5 000	3,1	32312 BJ2/QCL7C	5FD
	130	48,5	229	290	34	3 600	5 300	2,9	32312 J2/Q	2FD
65	100	23	96,5	127	14	5 000	6 000	0,63	* 32013 X/Q	4CC
	100	27	110	153	17,3	5 000	6 300	0,75	* 33013/Q	2CE
	110	28	123	183	21,2	4 300	6 300	1,05	JM 511946/910/Q	3DC
	110	31	138	193	22,4	4 300	6 300	1,15	T2DD 065/Q	2DD
	110	34	142	208	24	4 300	5 600	1,3	33113/Q	3DE
	120	24,75	132	134	16,3	4 500	5 600	1,1	* 30213 J2/Q	3EB
	120	32,75	151	193	22,8	4 000	5 600	1,5	32213 J2/Q	3EC
	120	41	194	270	30,5	3 800	5 300	2	33213/Q	3EE
	130	37	157	216	25,5	3 400	5 000	2,2	T7FC 065/QCL7C	7FC
	140	36	194	228	27,5	3 600	4 800	2,45	30313 J2/Q	2GB
	140	36	165	193	23,6	3 200	4 800	2,35	31313 J2/QCL7C	7GB
	140	51	246	345	40	3 200	4 800	3,75	32313 BJ2/QU4CL7CVQ267	5GD
	140	51	264	335	40	3 400	4 800	3,5	32313 J2/Q	2GD
70	110	25	101	153	17,3	4 300	5 600	0,85	32014 X/Q	4CC
	110	31	130	196	22,8	4 300	5 600	1,05	33014	2CE
	120	37	172	250	28,5	4 000	5 300	1,7	33114/Q	3DE
	125	26,25	125	156	18	4 000	5 300	1,25	30214 J2/Q	3EB
	125	33,25	157	208	24,5	3 800	5 300	1,6	32214 J2/Q	3EC
	125	41	201	285	32,5	3 600	5 000	2,1	33214/Q	3EE

* SKF Explorer bearing

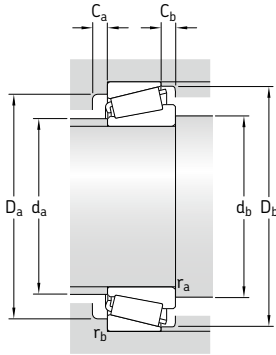

Dimensions						Abutment and fillet dimensions								Calculation factors				
d	d ₁	B	C	r _{1,2}	r _{3,4}	a	d _a	d _b	D _a	D _a	D _b	C _a	C _b	r _a	r _b	e	Y	Y ₀
							mm								-			
mm							mm								-			
60	77,8	23	17,5	1,5	1,5	21	67	67	85	88	91	4	5,5	1,5	1,5	0,43	1,4	0,8
	77,2	27	21	1,5	1,5	20	67	67	85	88	90	5	6	1,5	1,5	0,33	1,8	1
	80,5	30	23	1,5	1,5	23	67	67	88	93	96	5	7	1,5	1,5	0,4	1,5	0,8
	80,9	22	19	2	1,5	22	70	69	96	101	103	4	4,5	2	1,5	0,4	1,5	0,8
	81,9	28	24	2	1,5	24	69	69	95	101	104	4	5,5	2	1,5	0,4	1,5	0,8
	85,3	38	29	2	1,5	27	69	69	93	101	105	6	9	2	1,5	0,4	1,5	0,8
	85,6	39	33	2,5	2,5	28	70	71	98	104	109	6	7	2,5	2,5	0,33	1,8	1
	97,2	33,5	26	3	3	41	72	72	94	111	119	4	11	2,5	2,5	0,83	0,72	0,4
	91,8	31	26	3	2,5	26	77	72	112	118	120	5	7,5	3	2,5	0,35	1,7	0,9
	96	31	22	3	2,5	39	73	72	103	118	123	5	11,5	3	2,5	0,83	0,72	0,4
	98,6	46	37	3	2,5	38	71	72	100	118	122	6	11,5	3	2,5	0,54	1,1	0,6
	91,9	46	37	3	2,5	31	74	72	107	118	120	6	11,5	3	2,5	0,35	1,7	0,9
65	83,3	23	17,5	1,5	1,5	22	72	72	90	93	97	4	5,5	1,5	1,5	0,46	1,3	0,7
	82,6	27	21	1,5	1,5	21	72	72	89	93	96	5	6	1,5	1,5	0,35	1,7	0,9
	87,9	28	22,5	3	2,5	24	75	77	96	98	104	5	5,5	2,8	2,5	0,4	1,5	0,8
	85,7	31	25	2	2	23	74	75	97	100	105	5	6	2	2	0,33	1,8	1
	88,3	34	26,5	1,5	1,5	26	73	72	96	103	106	6	7,5	1,5	1,5	0,4	1,5	0,8
	89	23	20	2	1,5	23	77	74	106	111	113	4	4,5	2	1,5	0,4	1,5	0,8
	90,3	31	27	2	1,5	27	76	74	104	113	115	4	5,5	2	1,5	0,4	1,5	0,8
	92,5	41	32	2	1,5	29	74	74	102	111	115	6	9	2	1,5	0,4	1,5	0,8
	102	33,5	26	3	3	44	77	77	98	116	124	4	11	2,5	2,5	0,88	0,68	0,4
	98,7	33	28	3	2,5	28	83	77	122	128	130	5	8	3	2,5	0,35	1,7	0,9
	103	33	23	3	2,5	42	79	77	111	128	132	5	13	3	2,5	0,83	0,72	0,4
	105	48	39	3	2,5	41	77	77	109	128	133	6	12	3	2,5	0,54	1,1	0,6
99,2	48	39	3	2,5	33	80	77	117	128	130	6	12	3	2,5	0,35	1,7	0,9	
70	89,9	25	19	1,5	1,5	23	78	77	98	103	105	5	6	1,5	1,5	0,43	1,4	0,8
	88,9	31	25,5	1,5	1,5	23	78	77	98	103	105	5	6	1,5	1,5	0,28	2,1	1,1
	95,3	37	29	2	1,5	28	79	79	104	111	115	6	8	2	1,5	0,37	1,6	0,9
	94	24	21	2	1,5	25	81	79	110	116	118	4	5	2	1,5	0,43	1,4	0,8
	95	31	27	2	1,5	28	80	79	108	116	119	4	6	2	1,5	0,43	1,4	0,8
	97,4	41	32	2	1,5	30	79	79	107	116	120	7	9	2	1,5	0,4	1,5	0,8

7.1 Metric single row tapered roller bearings d 70 – 85 mm

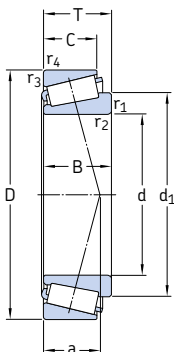

Principal dimensions	Basic load ratings		Fatigue load limit P_u	Speed ratings		Mass	Designation	Dimension series to ISO 355 (ABMA)		
	dynamic C	static C_0		Reference speed	Limiting speed					
d D T	kN		kN	r/min		kg	-	-		
70	130	43	233	325	38	3 800	5 600	2,45	T2ED 070/QCLNVB061	2ED
cont.	140	39	176	240	27,5	3 200	4 500	2,65	T7FC 070/QCL7C	7FC
	150	38	187	220	27	3 000	4 500	2,9	31314 J2/QCL7C	7GB
	150	38	220	260	31	3 400	4 500	2,95	30314 J2/Q	2GB
	150	54	281	400	45	3 000	4 300	4,55	32314 BJ2/QCL7C	5GD
	150	54	297	380	45	3 200	4 500	4,3	32314 J2/Q	2GD
75	105	20	70,4	116	13,2	4 300	6 300	0,48	32915 TN9/QVG900	2BC
	115	25	106	163	18,6	4 000	5 300	0,91	32015 X/Q	4CC
	115	31	134	228	26	4 000	5 300	1,15	33015/Q	2CE
	120	31	138	216	25	3 800	5 600	1,3	JM 714249/210/Q	(M 714200)
	125	37	176	265	30	3 800	5 000	1,8	33115/Q	3DE
	130	27,25	140	176	20,4	3 800	5 000	1,4	30215 J2/Q	4DB
	130	33,25	161	212	24,5	3 600	5 000	1,65	32215 J2/Q	4DC
	130	41	209	300	34	3 400	4 800	2,2	33215/Q	3DE
	145	52	297	450	50	3 400	4 800	3,9	T3FE 075/QVB481	3FE
	150	42	201	280	31	3 000	4 300	3,25	T7FC 075/QCL7C	7FC
	160	40	246	290	34	3 200	4 300	3,5	30315 J2/Q	2GB
	160	40	209	245	29	2 800	4 300	3,5	31315 J2/QCL7C	7GB
	160	58	336	475	53	2 800	4 000	5,55	32315 BJ2/QCL7C	5GD
	160	58	336	440	51	3 000	4 300	5,2	32315 J2	2GD
80	125	29	138	216	24,5	3 600	5 000	1,3	32016 X/Q	3CC
	125	36	168	285	32	3 600	5 000	1,65	33016/Q	2CE
	130	35	176	275	31	3 600	5 300	1,75	JM 515649/610/Q	3DD
	130	37	179	280	31	3 600	4 800	1,85	33116/Q	3DE
	140	28,25	151	183	21,2	3 400	4 800	1,6	30216 J2/Q	3EB
	140	35,25	187	245	28,5	3 400	4 500	2,05	32216 J2/Q	3EC
	140	46	251	375	41,5	3 200	4 500	2,9	33216/Q	3EE
	160	45	229	315	35,5	2 800	4 000	4	T7FC 080/QCL7C	7FC
	170	42,5	224	265	30,5	2 800	4 000	4,05	31316 J1/QCL7C	7GB
	170	42,5	270	320	36,5	3 000	4 300	4,15	30316 J2	2GB
	170	61,5	380	500	56	3 000	4 300	6,2	32316 J2	2GD
85	130	29	140	224	25,5	3 400	4 800	1,35	32017 X/Q	4CC
	130	36	183	310	34,5	3 600	4 800	1,75	33017/Q	2CE
	140	41	220	340	38	3 400	4 500	2,45	33117/Q	3DE
	150	30,5	176	220	25,5	3 200	4 300	2,05	30217 J2/Q	3EB

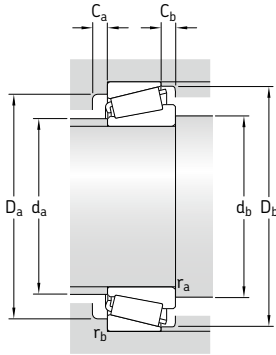

Dimensions

Abutment and fillet dimensions

Calculation factors

d	d ₁	B	C	r _{1,2}	r _{3,4}	a	d _a	d _b	D _a	D _a	D _b	C _a	C _b	r _a	r _b	e	Y	Y ₀
mm	~			min.	min.		max.	min.	min.	max.	min.	min.	min.	max.	max.	-		
70	98	42	35	8	2,5	30	81	82	111	118	123	7	8	7	2,5	0,33	1,8	1
cont.	110	35,5	27	3	3	47	82	82	106	126	133	5	12	2,5	2,5	0,88	0,68	0,4
	111	35	25	3	2,5	45	84	82	118	138	141	5	13	3	2,5	0,83	0,72	0,4
	105	35	30	3	2,5	29	89	82	130	138	140	5	8	3	2,5	0,35	1,7	0,9
	113	51	42	3	2,5	44	83	82	117	138	143	7	12	3	2,5	0,54	1,1	0,6
	106	51	42	3	2,5	36	86	82	125	138	140	6	12	3	2,5	0,35	1,7	0,9
75	89,7	20	16	1	1	19	81	81	98	99	101	4	4	1	1	0,33	1,8	1
	95,1	25	19	1,5	1,5	25	83	82	103	108	110	5	6	1,5	1,5	0,46	1,3	0,7
	95	31	25,5	1,5	1,5	23	84	82	104	108	110	6	5,5	1,5	1,5	0,3	2	1,1
	98,1	29,5	25	2,5	2,5	28	84	87	104	109	115	5	6	2,5	2	0,44	1,35	0,8
	100	37	29	2	1,5	29	84	84	109	116	120	6	8	2	1,5	0,4	1,5	0,8
	99,8	25	22	2	1,5	27	86	84	115	121	124	4	5	2	1,5	0,43	1,4	0,8
	100	31	27	2	1,5	29	85	84	115	121	124	4	6	2	1,5	0,43	1,4	0,8
	102	41	31	2	1,5	32	83	84	111	121	125	7	10	2	1,5	0,43	1,4	0,8
	111	51	43	11	3	39	88	82	117	139	138	7	9	11	3	0,43	1,4	0,8
	116	38	29	3	3	50	88	87	114	136	143	5	13	2,5	2,5	0,88	0,68	0,4
	112	37	31	3	2,5	31	95	87	139	148	149	5	9	3	2,5	0,35	1,7	0,9
	117	37	26	3	2,5	48	91	87	127	148	151	6	14	3	2,5	0,83	0,72	0,4
	119	55	45	3	2,5	46	90	87	124	148	151	7	14	3	2,5	0,54	1,1	0,6
	113	55	45	3	2,5	38	91	87	133	148	149	7	13	3	2,5	0,35	1,7	0,9
80	103	29	22	1,5	1,5	27	89	87	112	117	120	6	7	1,5	1,5	0,43	1,4	0,8
	102	36	29,5	1,5	1,5	26	90	87	112	117	119	6	6,5	1,5	1,5	0,28	2,1	1,1
	104	34	28,5	3	2,5	29	90	91	114	120	124	5	6,5	2,8	2,5	0,4	1,5	0,8
	105	37	29	2	1,5	30	89	89	114	121	126	6	8	2	1,5	0,43	1,4	0,8
	105	26	22	2,5	2	28	91	90	124	130	132	4	6	2,5	2	0,43	1,4	0,8
	106	33	28	2,5	2	30	90	90	122	130	134	5	7	2,5	2	0,43	1,4	0,8
	110	46	35	2,5	2	35	89	90	119	130	135	7	11	2,5	2	0,43	1,4	0,8
	125	41	31	3	3	53	94	92	121	146	152	5	14	2,5	2,5	0,88	0,68	0,4
	125	39	27	3	2,5	52	97	92	134	158	159	6	15,5	3	2,5	0,83	0,72	0,4
	122	39	33	3	2,5	33	102	92	148	158	159	5	9,5	3	2,5	0,35	1,7	0,9
	120	58	48	3	2,5	41	98	92	142	158	159	7	13,5	3	2,5	0,35	1,7	0,9
85	108	29	22	1,5	1,5	28	94	92	117	122	125	6	7	1,5	1,5	0,44	1,35	0,8
	107	36	29,5	1,5	1,5	26	94	92	118	122	125	6	6,5	1,5	1,5	0,3	2	1,1
	112	41	32	2,5	2	32	95	95	122	130	135	7	9	2,5	2	0,4	1,5	0,8
	112	28	24	2,5	2	30	97	95	132	140	141	5	6,5	2,5	2	0,43	1,4	0,8

7.1 Metric single row tapered roller bearings d 85 – 100 mm

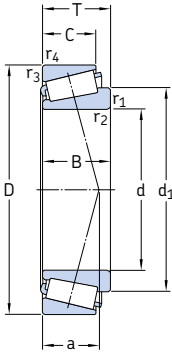

Principal dimensions			Basic load ratings		Fatigue load limit	Speed ratings		Mass	Designation	Dimension series to ISO 355 (ABMA)	
d	D	T	dynamic C	static C ₀	P _u	Reference speed	Limiting speed	kg			
mm			kN		kN	r/min		kg	-	-	
85	150	38,5	212	285	33,5	3 200	4 300	2,6	32217 J2/Q	3EC	
	150	49	286	430	48	3 000	4 300	3,55	33217/Q	3EE	
	180	44,5	303	365	40,5	2 800	4 000	4,85	30317 J2	2GB	
	180	44,5	242	285	32	2 600	3 800	4,6	31317 J2	7GB	
	180	63,5	391	560	62	2 800	4 000	7,6	32317 BJ2	5GD	
	180	63,5	402	530	60	2 800	4 000	7,1	32317 J2	2GD	
90	140	32	168	270	31	3 200	4 300	1,75	32018 X/Q	3CC	
	140	39	216	355	39	3 200	4 500	2,2	33018/Q	2CE	
	150	45	251	390	43	3 000	4 300	3,1	33118/Q	3DE	
	160	32,5	194	245	28,5	3 000	4 000	2,5	30218 J2	3FB	
	160	42,5	251	340	38	3 000	4 000	3,35	32218 J2/Q	3FC	
	190	46,5	330	400	44	2 600	4 000	5,65	30318 J2	2GB	
	190	46,5	264	315	35,5	2 400	3 400	5,4	31318 J2	7GB	
	190	67,5	457	610	65,5	2 600	4 000	8,4	32318 J2	2GD	
	95	145	32	168	270	30,5	3 200	4 300	1,85	32019 X/Q	4CC
		145	39	220	375	40,5	3 200	4 300	2,3	33019/Q	2CE
170		34,5	216	275	31,5	2 800	3 800	3	30219 J2	3FB	
170		45,5	281	390	43	2 800	3 800	4,1	32219 J2	3FC	
180		49	275	400	44	2 400	3 400	5,25	T7FC 095/CL7CVQ051	7FC	
200		49,5	330	390	42,5	2 600	3 400	6,45	30319	2GB	
200		49,5	292	355	39	2 400	3 400	6,3	31319 J2	7GB	
200		71,5	490	540	58,5	3 000	3 400	9,25	E2.32319	2GD	
200		71,5	501	670	72	2 400	3 400	9,8	32319 J2	2GD	
100		140	25	119	204	22,4	3 200	4 800	1,15	32920/Q	2CC
	145	24	125	190	20,8	3 200	4 500	1,2	T4CB 100/Q	4CB	
	150	32	172	280	31	3 000	4 000	1,9	32020 X/Q	4CC	
	150	39	224	390	41,5	3 000	4 000	2,4	33020/Q	2CE	
	157	42	246	400	42,5	3 000	4 300	2,9	HM 220149/110/Q	2DE	
	160	41	246	390	41,5	2 800	4 300	3,05	JHM 720249/210/Q	4DD	
	165	47	314	480	52	2 800	4 300	3,9	T2EE 100	2EE	
	180	37	246	320	36	2 800	3 600	3,6	30220 J2	3FB	
	180	49	319	440	48	2 600	3 600	4,95	32220 J2	3FC	
	180	63	429	655	71	2 400	3 600	6,7	33220	3FE	

E2 → SKF Energy Efficient bearing

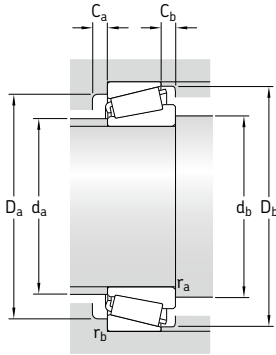
Dimensions
Abutment and fillet dimensions
Calculation factors

d	d ₁	B	C	r _{1,2}	r _{3,4}	a	d _a	d _b	D _a	D _a	D _b	C _a	C _b	r _a	r _b	e	Y	Y ₀
mm	mm	mm	mm	mm	mm	mm	mm	mm	mm	mm	mm	mm	mm	mm	mm	mm	mm	mm
85 cont.	113	36	30	2,5	2	33	96	95	130	140	142	5	8,5	2,5	2	0,43	1,4	0,8
	117	49	37	2,5	2	37	95	95	128	140	144	7	12	2,5	2	0,43	1,4	0,8
	126	41	34	4	3	35	107	99	156	166	167	6	10,5	4	3	0,35	1,7	0,9
	131	41	28	4	3	54	103	99	143	166	169	6	16,5	4	3	0,83	0,72	0,4
	135	60	49	4	3	52	102	99	138	166	169	7	14,5	4	3	0,54	1,1	0,6
	127	60	49	4	3	42	103	99	150	166	167	8	14,5	4	3	0,35	1,7	0,9
90	115	32	24	2	1,5	30	100	99	125	131	134	6	8	2	1,5	0,43	1,4	0,8
	114	39	32,5	2	1,5	27	100	99	127	131	135	7	6,5	2	1,5	0,27	2,2	1,3
	120	45	35	2,5	2	35	100	100	130	140	144	7	10	2,5	2	0,4	1,5	0,8
	120	30	26	2,5	2	31	103	100	140	150	150	5	6,5	2,5	2	0,43	1,4	0,8
	121	40	34	2,5	2	36	102	100	138	150	152	5	8,5	2,5	2	0,43	1,4	0,8
	133	43	36	4	3	36	113	104	165	176	176	6	10,5	4	3	0,35	1,7	0,9
95	118	43	30	4	3	57	109	104	151	176	179	6	16,5	4	3	0,83	0,72	0,4
	133	64	53	4	3	44	108	104	157	176	177	8	14,5	4	3	0,35	1,7	0,9
	120	32	24	2	1,5	31	105	104	130	136	140	6	8	2	1,5	0,44	1,35	0,8
	118	39	32,5	2	1,5	28	104	104	131	136	139	7	6,5	2	1,5	0,28	2,1	1,1
	126	32	27	3	2,5	33	110	107	149	158	159	5	7,5	3	2,5	0,43	1,4	0,8
	128	43	37	3	2,5	39	108	107	145	158	161	5	8,5	3	2,5	0,43	1,4	0,8
100	143	45	33	4	4	60	109	110	138	164	172	6	16	3	3	0,88	0,68	0,4
	139	45	38	4	3	39	118	109	172	186	184	6	11,5	4	3	0,35	1,7	0,9
	145	45	32	4	3	60	114	109	157	186	187	6	17,5	4	3	0,83	0,72	0,4
	141	67	55	4	3	47	115	109	166	186	186	8	16,5	4	3	0,35	1,7	0,9
	141	67	55	4	3	47	115	109	166	186	186	8	16,5	4	3	0,35	1,7	0,9
	119	25	20	1,5	1,5	24	109	107	131	131	135	5	5	1,5	1,5	0,33	1,8	1
100	121	22,5	17,5	3	3	30	109	112	133	131	140	4	6,5	2,5	2,5	0,48	1,25	0,7
	125	32	24	2	1,5	32	109	109	134	141	144	6	8	2	1,5	0,46	1,3	0,7
	122	39	32,5	2	1,5	29	108	109	135	141	143	7	6,5	2	1,5	0,28	2,1	1,1
	127	42	34	8	3,5	32	111	124	140	145	151	7	8	7	3,3	0,33	1,8	1
	130	40	32	3	2,5	38	110	112	139	148	154	7	9	2,8	2,5	0,48	1,25	0,7
	129	46	39	3	3	35	111	112	145	151	157	7	8	2,5	2,5	0,31	1,9	1,1
	133	34	29	3	2,5	35	116	112	157	168	168	5	8	3	2,5	0,43	1,4	0,8
	136	46	39	3	2,5	41	114	112	154	168	171	5	10	3	2,5	0,43	1,4	0,8
	139	63	48	3	2,5	45	112	112	151	168	172	10	15	3	2,5	0,4	1,5	0,8

7.1 Metric single row tapered roller bearings d 100 – 130 mm

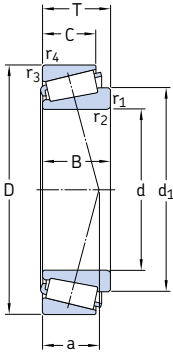

Principal dimensions			Basic load ratings		Fatigue load limit P_u	Speed ratings		Mass	Designation	Dimension series to ISO 355 (ABMA)	
d	D	T	dynamic C	static C_0		Reference speed	Limiting speed				
mm			kN		kN	r/min		kg	-	-	
100	215	51,5	402	490	53	2 400	3 200	7,95	30320 J2	2GB	
	cont. 215	56,5	374	465	51	2 200	3 000	8,6	31320 XJ2/CL7CVQ051	7GB	
	215	77,5	572	780	83	2 200	3 200	12,5	32320 J2	2GD	
105	160	35	201	335	37,5	2 800	3 800	2,45	32021 X/Q	4DC	
	160	43	246	430	45,5	2 800	3 800	3	33021/Q	2DE	
	190	39	270	355	40	2 600	3 400	4,3	30221 J2	3FB	
	190	53	358	510	55	2 600	3 400	6,05	32221 J2	3FC	
	225	81,5	605	815	85	2 000	3 000	14	32321 J2	2GD	
110	150	25	125	224	24	3 000	4 300	1,25	32922/Q	2CC	
	170	38	232	320	32,5	3 400	3 600	2,95	E2.32022 X	4DC	
	170	38	233	390	42,5	2 600	3 600	3,05	32022 X/Q	4DC	
	170	47	281	500	53	2 600	3 600	3,85	33022	2DE	
	180	56	369	630	65,5	2 600	3 400	5,5	33122	3EE	
	200	41	308	405	43	2 400	3 200	5,05	30222 J2	3FB	
	200	56	402	570	61	2 400	3 200	7,1	32222 J2	3FC	
	240	54,5	473	585	62	2 200	2 800	11	30322 J2	2GB	
	240	63	457	585	61	1 900	2 800	12	31322 XJ2	7GB	
	240	84,5	627	830	86,5	1 900	2 800	16,5	32322	2GD	
	120	165	29	165	305	32	2 600	3 800	1,8	32924	2CC
		170	27	157	250	26,5	2 600	3 800	1,75	T4CB 120	4CB
		180	38	242	415	42,5	2 400	3 400	3,3	32024 X	4DC
180		48	292	540	56	2 600	3 400	4,15	33024	2DE	
215		43,5	341	465	49	2 200	3 000	6,1	30224 J2	4FB	
215		61,5	468	695	72	2 200	3 000	9,05	32224 J2	4FD	
260		59,5	561	710	73,5	2 000	2 600	13,5	30324 J2	2GB	
260		68	539	695	72	1 700	2 400	15,5	31324 XJ2	7GB	
260		90,5	780	900	90	2 200	2 600	20	E2.32324	2GD	
260		90,5	792	1 120	110	1 800	2 600	21,5	32324 J2	2GD	
130		180	32	198	365	38	2 400	3 600	2,4	32926	2CC
	200	45	314	540	55	2 200	3 000	4,95	32026 X	4EC	
	230	43,75	369	490	51	2 000	2 800	6,85	30226 J2	4FB	
	230	67,75	540	680	69,5	2 600	2 800	10,5	E2.32226	4FD	
	230	67,75	550	830	85	2 000	2 800	11	32226 J2	4FD	

E2 → SKF Energy Efficient bearing

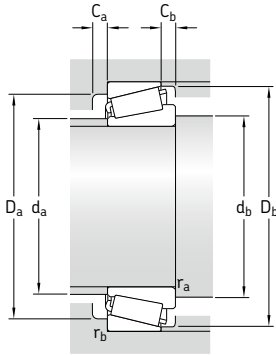

Dimensions

Abutment and fillet dimensions

Calculation factors

d	d ₁	B	C	r _{1,2}	r _{3,4}	a	d _a	d _b	D _a	D _a	D _b	C _a	C _b	r _a	r _b	e	Y	Y ₀
							mm							-				
100 cont.	149	47	39	4	3	40	127	114	184	201	197	6	12,5	4	3	0,35	1,7	0,9
	158	51	35	4	3	65	121	114	168	201	202	7	21,5	4	3	0,83	0,72	0,4
	152	73	60	4	3	51	123	114	177	201	200	8	17,5	4	3	0,35	1,7	0,9
105	132	35	26	2,5	2	34	116	115	143	150	154	6	9	2,5	2	0,44	1,35	0,8
	131	43	34	2,5	2	31	116	115	145	150	153	7	9	2,5	2	0,28	2,1	1,1
	143	36	30	3	2,5	37	122	117	165	178	177	6	9	3	2,5	0,43	1,4	0,8
	143	50	43	3	2,5	44	120	117	161	178	180	5	10	3	2,5	0,43	1,4	0,8
	158	77	63	4	3	53	128	119	185	211	209	9	18,5	4	3	0,35	1,7	0,9
110	129	25	20	1,5	1,5	26	118	117	140	143	145	5	5	1,5	1,5	0,35	1,7	0,9
	140	38	29	2,5	2	36	122	120	152	160	163	7	9	2,5	2	0,43	1,4	0,8
	140	38	29	2,5	2	36	123	120	152	160	163	7	9	2,5	2	0,43	1,4	0,8
	139	47	37	2,5	2	34	123	120	152	160	161	7	10	2,5	2	0,28	2,1	1,1
	146	56	43	2,5	2	44	121	120	155	170	174	9	13	2,5	2	0,43	1,4	0,8
	149	38	32	3	2,5	39	129	122	174	188	187	6	9	3	2,5	0,43	1,4	0,8
	151	53	46	3	2,5	46	126	122	170	188	190	6	10	3	2,5	0,43	1,4	0,8
	166	50	42	4	3	43	141	124	206	226	220	8	12,5	4	3	0,35	1,7	0,9
	176	57	38	4	3	72	135	124	188	226	224	7	25	4	3	0,83	0,72	0,4
	169	80	65	4	3	55	137	124	198	226	222	9	19,5	4	3	0,35	1,7	0,9
120	142	29	23	1,5	1,5	29	128	127	154	157	160	6	6	1,5	1,5	0,35	1,7	0,9
	143	25	19,5	3	3	34	130	132	157	157	164	4	7,5	2,5	2,5	0,48	1,25	0,7
	150	38	29	2,5	2	39	131	130	161	170	173	7	9	2,5	2	0,46	1,3	0,7
	149	48	38	2,5	2	36	132	130	160	170	171	6	10	2,5	2	0,3	2	1,1
	161	40	34	3	2,5	43	140	132	187	203	201	6	9,5	3	2,5	0,43	1,4	0,8
	164	58	50	3	2,5	51	136	132	181	203	204	7	11,5	3	2,5	0,43	1,4	0,8
	178	55	46	4	3	47	152	134	221	246	237	10	13,5	4	3	0,35	1,7	0,9
	191	62	42	4	3	78	145	134	203	246	244	9	26	4	3	0,83	0,72	0,4
	181	86	69	4	3	60	148	134	213	246	239	9	21,5	4	3	0,35	1,7	0,9
	181	86	69	4	3	60	148	134	213	246	239	9	21,5	4	3	0,35	1,7	0,9
130	153	32	25	2	1,5	31	141	139	167	171	173	6	7	2	1,5	0,33	1,8	1
	165	45	34	2,5	2	43	144	140	178	190	192	8	11	2,5	2	0,43	1,4	0,8
	173	40	34	4	3	45	152	144	203	216	217	7	9,5	4	3	0,43	1,4	0,8
	176	64	54	4	3	56	146	144	193	216	219	7	13,5	4	3	0,43	1,4	0,8
	176	64	54	4	3	56	146	144	193	216	219	7	13,5	4	3	0,43	1,4	0,8

7.1 Metric single row tapered roller bearings d 130 – 190 mm

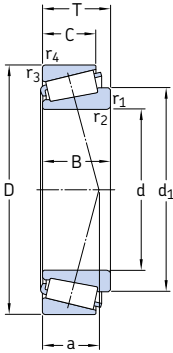

Principal dimensions			Basic load ratings		Fatigue load limit P_u	Speed ratings		Mass	Designation	Dimension series to ISO 355 (ABMA)
d	D	T	dynamic C	static C_0		Reference speed	Limiting speed			
mm			kN		kN	r/min		kg	-	-
130	280	63,75	627	800	81,5	1 800	2 400	17	30326 J2	2GB
cont.	280	72	605	780	80	1 600	2 400	18,5	31326 XJ2	7GB
140	190	32	205	390	40	2 200	3 400	2,55	32928	2CC
	195	29	194	325	33,5	2 200	3 200	2,4	T4CB 140	4CB
	210	45	330	585	58,5	2 200	2 800	5,25	32028 X	4DC
	250	45,75	418	570	58,5	1 900	2 600	8,7	30228 J2	4FB
	250	71,75	644	1 000	100	1 900	2 600	14	32228 J2	4FD
	300	77	693	900	90	1 500	2 200	22,5	31328 XJ2	7GB
150	210	32	233	390	40	2 000	3 000	3,1	T4DB 150	4DB
	225	48	369	655	65,5	2 000	2 600	6,4	32030 X	4EC
	225	59	457	865	85	2 000	2 600	8,05	33030	2EE
	270	49	429	560	57	1 800	2 400	10,5	30230	4GB
	270	77	737	1 140	112	1 700	2 400	18	32230 J2	4GD
	320	82	781	1 020	100	1 400	2 000	27	31330 XJ2	7GB
160	220	32	242	415	41,5	2 000	2 800	3,25	T4DB 160	4DB
	240	51	429	780	76,5	1 800	2 400	7,85	32032 X	4EC
	245	61	528	980	96,5	1 800	2 600	10,5	T4EE 160/VB406	4EE
	290	52	528	735	72	1 600	2 200	13	30232 J2	4GB
	290	84	880	1 400	132	1 600	2 200	23	32232 J2	4GD
	340	75	913	1 180	114	1 500	2 000	29	30332 J2	2GB
170	230	32	251	440	43	1 900	2 800	3,45	T4DB 170	4DB
	230	38	286	585	55	1 900	2 800	4,5	32934	3DC
	260	57	512	915	88	1 700	2 200	10,5	32034 X	4EC
	310	57	616	865	83	1 500	2 000	16,5	30234 J2	4GB
	310	91	1 010	1 630	150	1 500	2 000	28,5	32234 J2	4GD
180	240	32	251	450	44	1 800	2 600	3,6	T4DB 180	4DB
	250	45	352	735	68	1 700	2 600	6,65	32936	4DC
	280	64	644	1 160	110	1 600	2 200	14	32036 X	3FD
	320	57	583	815	80	1 500	2 000	17	30236 J2	4GB
	320	91	1 010	1 630	150	1 400	1 900	29,5	32236 J2	4GD
190	260	45	358	765	72	1 600	2 400	7	32938	4DC
	260	46	358	765	72	1 600	2 400	7	JM 738249/210	4DD
	290	64	660	1 200	112	1 500	2 000	15	32038 X	4FD
	340	60	721	1 000	95	1 400	1 800	20,5	30238 J2	4GB
	340	97	1 190	1 930	176	1 300	1 800	36	32238 J2	4GD

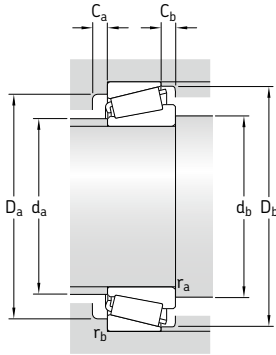

Dimensions

Abutment and fillet dimensions

Calculation factors

d	d ₁	B	C	r _{1,2}	r _{3,4}	a	d _a	d _b	D _a	D _a	D _b	C _a	C _b	r _a	r _b	e	Y	Y ₀
mm	~			min.	min.		max.	min.	min.	max.	min.	min.	min.	max.	max.	-		
130	192	58	49	5	4	51	164	148	239	262	255	8	14,5	5	4	0,35	1,7	0,9
	cont.	204	66	44	5	4	84	157	148	218	262	261	9	28	5	4	0,83	0,72
140	164	32	25	2	1,5	33	150	149	177	181	184	6	7	2	1,5	0,35	1,7	0,9
	165	27	21	3	3	40	151	154	180	181	189	5	8	2,5	2,5	0,5	1,2	0,7
	175	45	34	2,5	2	46	153	150	187	200	202	8	11	2,5	2	0,46	1,3	0,7
	187	42	36	4	3	47	163	154	219	236	234	9	9,5	4	3	0,43	1,4	0,8
	191	68	58	4	3	60	159	154	210	236	238	8	13,5	4	3	0,43	1,4	0,8
	220	70	47	5	4	90	169	158	235	282	280	9	30	5	4	0,83	0,72	0,4
	220	70	47	5	4	90	169	158	235	282	280	9	30	5	4	0,83	0,72	0,4
150	177	30	23	3	3	41	162	162	194	196	203	5	9	2,5	2,5	0,46	1,3	0,7
	187	48	36	3	2,5	49	164	162	200	213	216	8	12	3	2,5	0,46	1,3	0,7
	188	59	46	3	2,5	48	164	162	200	213	217	8	13	3	2,5	0,37	1,6	0,9
	200	45	38	4	3	50	175	164	234	256	250	9	11	4	3	0,43	1,4	0,8
	205	73	60	4	3	64	171	164	226	256	254	8	17	4	3	0,43	1,4	0,8
	234	75	50	5	4	96	181	168	251	302	300	9	32	5	4	0,83	0,72	0,4
	234	75	50	5	4	96	181	168	251	302	300	9	32	5	4	0,83	0,72	0,4
160	187	30	23	3	3	44	172	174	204	206	213	5	9	2,5	2,5	0,48	1,25	0,7
	200	51	38	3	2,5	52	175	172	213	228	231	8	13	3	2,5	0,46	1,3	0,7
	204	59	50	3	2	57	174	182	212	236	236	10	11	3	2	0,44	1,35	0,8
	215	48	40	4	3	54	189	174	252	276	269	9	12	4	3	0,43	1,4	0,8
	222	80	67	4	3	70	183	174	242	276	274	10	17	4	3	0,43	1,4	0,8
	233	68	58	5	4	61	201	180	290	323	310	9	17	5	4	0,35	1,7	0,9
	233	68	58	5	4	61	201	180	290	323	310	9	17	5	4	0,35	1,7	0,9
170	197	30	23	3	3	44	182	184	215	216	223	6	9	2,5	2,5	0,46	1,3	0,7
	200	38	30	2,5	2	42	183	180	213	220	222	7	8	2,5	2	0,37	1,6	0,9
	214	57	43	3	2,5	56	187	182	230	248	249	10	14	3	2,5	0,44	1,35	0,8
	231	52	43	5	4	58	203	188	269	292	288	8	14	5	4	0,43	1,4	0,8
	238	86	71	5	4	75	196	188	259	292	294	10	20	5	4	0,43	1,4	0,8
	238	86	71	5	4	75	196	188	259	292	294	10	20	5	4	0,43	1,4	0,8
	238	86	71	5	4	75	196	188	259	292	294	10	20	5	4	0,43	1,4	0,8
180	207	30	23	3	3	48	191	192	224	226	233	6	9	2,5	2,5	0,48	1,25	0,7
	216	45	34	2,5	2	53	193	190	225	240	241	8	11	2,5	2	0,48	1,25	0,7
	230	64	48	3	2,5	59	199	192	247	268	267	10	16	3	2,5	0,43	1,4	0,8
	240	52	43	5	4	61	211	198	278	302	297	9	14	5	4	0,46	1,3	0,7
	247	86	71	5	4	78	204	198	267	302	303	10	20	5	4	0,46	1,3	0,7
	247	86	71	5	4	78	204	198	267	302	303	10	20	5	4	0,46	1,3	0,7
	247	86	71	5	4	78	204	198	267	302	303	10	20	5	4	0,46	1,3	0,7
190	227	45	34	2,5	2	55	204	200	235	249	251	8	11	2,5	2	0,48	1,25	0,7
	227	44	36,5	3	4	55	205	204	235	256	252	8	9,5	2,8	2,5	0,48	1,25	0,7
	240	64	48	3	2,5	62	209	202	257	278	279	10	16	3	2,5	0,44	1,35	0,8
	254	55	46	5	4	63	224	207	298	322	318	9	14	5	4	0,43	1,4	0,8
	262	92	75	5	4	81	217	210	286	323	323	12	22	5	4	0,43	1,4	0,8
	262	92	75	5	4	81	217	210	286	323	323	12	22	5	4	0,43	1,4	0,8
	262	92	75	5	4	81	217	210	286	323	323	12	22	5	4	0,43	1,4	0,8

7.1 Metric single row tapered roller bearings d 200 – 360 mm

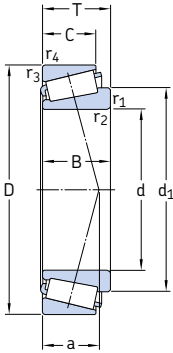

Principal dimensions			Basic load ratings		Fatigue load limit P_u	Speed ratings		Mass	Designation	Dimension series to ISO 355 (ABMA)
d	D	T	dynamic C	static C_0		Reference speed	Limiting speed			
mm			kN		kN	r/min		kg	-	-
200	270	37	330	600	57	1 600	2 400	5,5	T4DB 200	4DB
	280	51	473	950	88	1 500	2 200	9,5	32940	3EC
	310	70	748	1 370	127	1 400	1 900	19	32040 X	4FD
	360	64	792	1 120	106	1 300	1 700	24,5	30240 J2	4GB
	360	104	1 210	2 000	180	1 300	1 700	42,5	32240 J2	3GD
220	300	51	484	1 000	91,5	1 400	2 000	10	32944	3EC
	340	76	897	1 660	150	1 300	1 700	24,5	32044 X	4FD
	400	72	990	1 400	127	1 200	1 600	34,5	30244 J2	3GB
	400	114	1 610	2 700	232	1 100	1 500	59,5	32244 J2	4GD
240	320	42	429	815	73,5	1 300	1 900	8,45	T4EB 240/VE174	4EB
	320	51	512	1 080	96,5	1 300	1 900	11	32948	4EC
	320	57	616	1 320	118	1 300	1 900	12,5	T2EE 240/VB406	2EE
	360	76	935	1 800	156	1 200	1 600	26,5	32048 X	4FD
	440	127	1 790	3 350	270	1 000	1 300	83,5	32248 J3	4GD
260	400	87	1 170	2 200	190	1 100	1 400	38	32052 X	4FC
	480	137	2 200	3 650	300	900	1 200	105	32252 J2/HA1	4GD
	540	113	2 120	3 050	250	850	1 200	110	30352 J2	2GB
280	380	63,5	765	1 660	143	1 100	1 600	20	32956/C02	4EC
	420	87	1 210	2 360	200	1 000	1 300	40,5	32056 X	4FC
300	420	76	1 050	2 240	186	950	1 400	31,5	32960	3FD
	460	100	1 540	3 000	250	900	1 200	58	32060 X	4GD
	540	149	2 750	4 750	365	800	1 100	140	32260 J2/HA1	4GD
320	440	76	1 080	2 360	196	900	1 300	33,5	32964	3FD
	480	100	1 540	3 100	255	850	1 100	64	32064 X	4GD
340	460	76	1 080	2 400	200	850	1 300	35	32968	4FD
360	480	76	1 120	2 550	204	800	1 200	37	32972	4FD

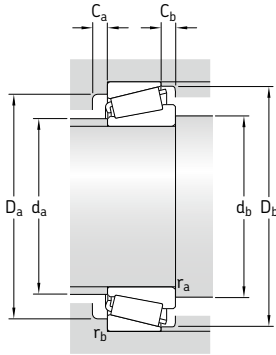

Dimensions

Abutment and fillet dimensions

Calculation factors

d	d_1	B	C	$r_{1,2}$	$r_{3,4}$	a	d_a	d_b	D_a	D_a	D_b	C_a	C_b	r_a	r_b	e	Y	Y_0
							mm									-		
200	232	34	27	3	3	53	214	214	251	255	262	6	10	2,5	2,5	0,48	1,25	0,7
	240	51	39	3	2,5	53	216	212	257	268	271	9	12	3	2,5	0,4	1,5	0,8
	254	70	53	3	2,5	66	222	214	273	296	297	11	17	2,5	2,5	0,43	1,4	0,8
	269	58	48	5	4	68	237	217	315	342	336	9	16	5	4	0,43	1,4	0,8
	274	98	82	5	4	82	226	217	302	342	340	11	22	5	4	0,4	1,5	0,8
220	259	51	39	3	2,5	58	234	232	275	288	290	9	12	3	2,5	0,43	1,4	0,8
	280	76	57	4	3	72	243	234	300	326	326	12	19	4	3	0,43	1,4	0,8
	295	65	54	5	4	74	259	242	348	383	371	10	18	4	3	0,43	1,4	0,8
	306	108	90	5	4	95	253	242	334	383	379	13	24	4	3	0,43	1,4	0,8
	240	276	39	30	3	3	60	256	254	299	305	310	7	12	2,5	2,5	0,46	1,3
280		51	39	3	2,5	64	254	252	294	308	311	9	12	3	2,5	0,46	1,3	0,7
276		56	46	3	2	58	254	266	296	303	311	9	11	3	2	0,35	1,7	0,9
300		76	57	4	3	78	261	254	318	346	346	12	19	4	3	0,46	1,3	0,7
346		120	100	5	4	105	290	251	365	430	415	13	27	4	3	0,43	1,4	0,8
260	328	87	65	5	4	84	287	278	352	382	383	14	22	5	4	0,43	1,4	0,8
	366	130	106	6	5	112	304	272	401	470	454	17	31	5	4	0,43	1,4	0,8
	376	102	85	6	6	97	325	286	461	514	493	15	28	5	5	0,35	1,7	0,9
280	329	63,5	48	3	2,5	74	298	292	348	368	368	11	15,5	3	2,5	0,43	1,4	0,8
	348	87	65	5	4	89	305	298	370	402	402	14	22	5	4	0,46	1,3	0,7
300	359	76	57	4	3	79	324	314	383	406	405	12	19	4	3	0,4	1,5	0,8
	377	100	74	5	4	97	329	318	404	442	439	15	26	5	4	0,43	1,4	0,8
	412	140	115	6	5	126	346	312	453	530	511	17	34	5	4	0,43	1,4	0,8
320	379	76	57	4	3	84	343	334	402	426	426	13	19	4	3	0,43	1,4	0,8
	399	100	74	5	4	103	350	338	424	462	461	15	26	5	4	0,46	1,3	0,7
340	399	76	57	4	3	90	361	354	421	446	446	14	19	4	3	0,44	1,35	0,8
360	419	76	57	4	3	96	380	374	439	466	466	14	19	4	3	0,46	1,3	0,7

7.2 Inch single row tapered roller bearings

d **14,989 – 26,162 mm**

0.5901 – 1.03 in.

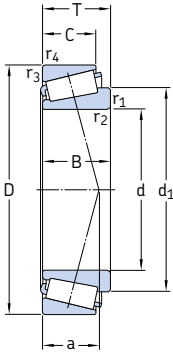

Principal dimensions			Basic load ratings		Fatigue load limit P_u	Speed ratings		Mass	Designation	Series			
d	D	T	dynamic C	static C_0		Reference speed	Limiting speed						
mm/in.			kN		kN	r/min		kg	–	–			
14,989 0.5901	34,988 1.3775	10,998 0.433	13,4	13,2	1,29	16 000	22 000	0,051	A 4059/A 4138	A 4000			
15,875 0.625	41,275	14,288	22	21,2	2,16	20 000	20 000	0,095	03062/03162/Q	03000			
	1,625	0,5625	17,6	17,6	1,8	12 000	17 000	0,1	11590/11520	11500			
	42,862	14,288											
1,6875	0,5625												
17,462 0.6875	39,878 1.57	13,843 0.545	21,2	20,8	2,12	13 000	20 000	0,082	LM 11749/710/Q	LM 11700			
19,05 0.75	45,237	15,494	27,5	27,5	2,9	12 000	18 000	0,12	LM 11949/910/Q	LM 11900			
	1,781	0,61	47,3	52	5,6	11 000	17 000	0,17	09067/09195/Q	09000			
	49,225	18,034											
	1,938	0,71	39,1	40	4,3	11 000	17 000	0,19	09074/09195/QVQ494	09000			
49,225	19,845	1,938	0,7813										
21,43 0.8437	45,237 1.781	15,492 0.6099	27,5	31	3,2	11 000	17 000	0,12	LM 12748/710	LM 12700			
21,986 0.8656	45,237	15,494	27,5	31	3,2	11 000	17 000	0,12	LM 12749/710/Q	LM 12700			
	1,781	0,61	45,974	15,494	1,81	0,61	27,5	31	3,2	11 000	17 000	0,12	LM 12749/711/Q
25,4 1	50,292	14,224	26	30	3	10 000	15 000	0,13	L 44643/610	L 44600			
	1,98	0,56	50,8	15,011	28,1	30,5	3,15	15 000	15 000	0,13	07100 S/07210 X/Q	07000	
	2	0,591											
	57,15	17,462	40,2	45,5	4,9	9 000	13 000	0,22	15578/15520	15500			
	2,25	0,6875	57,15	19,431	39,6	45	5	9 000	13 000	0,24	M 84548/2/510/2/QVQ506	M 84500	
	2,25	0,765											
62	19,05	48,4											57
2,4409	0,75												
26,162 1.03	61,912	19,05	48,4	57	6,2	8 000	12 000	0,29	15103 S/15243/Q	15000			
	2,4375	0,75	62	19,05	48,4	57	6,2	8 000	12 000	0,29	15103 S/15245/Q	15000	
	2,4409	0,75											

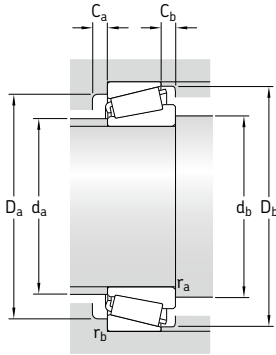

Dimensions				Abutment and fillet dimensions										Calculation factors					
d	d ₁	B	C	r _{1,2}	r _{3,4}	a	d _a	d _b	D _a	D _a	D _b	C _a	C _b	r _a	r _b	e	Y	Y ₀	
mm/in.							mm										-		
14,989 0.5901	25,3	10,988 0.4326	8,73 0.3437	0,8 0.03	1,3 0.05	8	20	20	28	29	31	2	2	0,8	1,3	0,46	1,3	0,7	
15,875 0.625	28,1	14,681 0.578	11,112 0.4375	1,3 0.05	2 0.08	9	22	22	33,5	33,5	37	2	3	1,3	2	0,31	1,9	1,1	
	31,1	14,34 0.5646	9,58 0.3772	1,5 0.06	1,5 0.06	13	23	23	32	36	38	2	4,5	1,5	1,5	0,72	0,84	0,45	
17,462 0.6875	28,7	14,605 0.575	10,668 0.42	1,3 0.05	1,3 0.05	9	23	24	33,5	33,5	36	2	3	1,3	1,3	0,28	2,1	1,1	
19,05 0.75	31,4	16,6373 0.655	12,065 0.475	1,3 0.05	1,3 0.05	10	25	25,5	38	38,5	41	3	3	1,3	1,3	0,3	2	1,1	
	19	19,05 0.75	14,288 0.5625	1,3 0.05	1,3 0.05	10	26	25	41	42,5	44	4	3,5	1,3	1,3	0,27	2,2	1,3	
	32,3	21,539 0.848	14,288 0.5625	1,5 0.06	1,3 0.05	10	26	26	41	42,5	44	5	5,5	1,5	1,3	0,27	2,2	1,3	
21,43 0.8437	33,9	16,637 0.655	12,065 0.475	1,3 0.05	1,3 0.05	10	28	27,5	39	40	42	3	3	1,3	1,3	0,31	1,9	1,1	
21,986 0.8656	33,9	16,637 0.655	12,065 0.475	1,3 0.05	1,3 0.05	10	28	28,5	39	39,5	42	3	3	1,3	1,3	0,31	1,9	1,1	
	33,9	16,637 0.655	12,065 0.475	1,3 0.05	1,3 0.05	10	28	28,5	39	40	42	3	3	1,3	1,3	0,31	1,9	1,1	
25,4 1	39,1	14,732 0.58	10,668 0.42	1,3 0.05	1,3 0.05	11	33	31,5	43,5	43,5	47	2	3,5	1,3	1,3	0,37	1,6	0,9	
	38	14,26 0.5614	12,7 0.5	1,5 0.06	1,5 0.06	12	31	32,5	41	43,5	48	2	2	1,5	1,5	0,4	1,5	0,8	
	42,3	17,513 0.6895	13,55 0.5335	1,3 0.05	1,5 0.06	12	35	31,5	49	50	53	3	3,5	1,3	1,5	0,35	1,7	0,9	
	42,5	19,431 0.765	14,732 0.58	1,5 0.06	1,5 0.06	16	33	32,5	45	49	53	3	4,5	1,5	1,5	0,54	1,1	0,6	
	45,8	20,638 0.8125	14,288 0.5625	0,8 0.03	1,3 0.05	13	38	30,5	54	55	58	4	4,5	0,8	1,3	0,35	1,7	0,9	
26,162 1.03	45,8	19,99 0.787	14,288 0.5625	0,8 0.03	2 0.08	13	38	31	54	55	54	4	4,5	0,8	2	0,35	1,7	0,9	
	45,8	19,99 0.787	14,288 0.5625	0,8 0.03	1,3 0.05	13	38	31	54	55	58	4	4,5	0,8	1,3	0,35	1,7	0,9	

7.2 Inch single row tapered roller bearings

d 26,988 – 34,925 mm

1.0625 – 1.375 in.

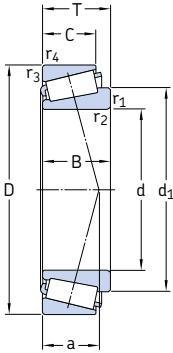

Principal dimensions			Basic load ratings		Fatigue load limit P_u	Speed ratings		Mass	Designation	Series
d	D	T	dynamic C	static C_0		Reference speed	Limiting speed			
mm/in.			kN		kN	r/min		kg	-	-
26,988 1.0625	50,292 1.98	14,224 0.56	26	30	3	10 000	15 000	0,11	L 44649/610/Q	L 44600
27,5 1.0827	57,15 2.25	19,845 0.7813	45,7	51	5,6	9 000	13 000	0,22	1982 F/1924 A/QV0519	1900
28,575 1.125	57,15 2.25	19,845 0.7813	47,3	55	6	9 000	13 000	0,23	1985/1922/Q	1900
	57,15 2.25	19,845 0.7813	47,3	55	6	9 000	13 000	0,22	1988/1922/Q	1900
	64,292 2.5312	21,433 0.8438	49,5	61	6,8	8 000	11 000	0,35	M 86647/610/QCL7C	M 86600
29 1.1417	73,025 2.875	22,225 0.875	57,2	69,5	7,5	7 000	10 000	0,49	02872/02820/Q	02800
	50,292 1.98	14,224 0.56	26	32,5	3,35	9 500	14 000	0,11	L 45449/410/Q	L 45400
	64,292 2.5312	21,433 0.8438	49,5	61	6,8	8 000	11 000	0,33	M 86649/2/610/2/QV0506	M 86600
30,162 1.1875	68,262 2.6875	22,225 0.875	55	69,5	7,8	7 500	11 000	0,41	M 88043/010/2/QCL7C	M 88000
	59,131 2.328	15,875 0.625	34,7	41,5	4,4	8 500	12 000	0,18	LM 67048/010/Q	LM 67000
	61,912 2.4375	18,161 0.715	48,4	57	6,2	8 000	12 000	0,24	15123/15243/Q	15000
31,75 1.25	62 2.4409	18,161 0.715	48,4	57	6,2	8 000	12 000	0,24	15123/15245/Q	15000
	73,025 2.875	29,37 1.1563	70,4	95	10,6	6 700	10 000	0,62	HM 88542/510/Q	HM 88500
	68,262 2.6875	22,225 0.875	55	69,5	7,8	7 500	11 000	0,38	M 88048/2/010/2/QCL7C	M 88000
34,925 1.375	65,088 2.5625	18,034 0.71	47,3	57	6,2	7 500	11 000	0,26	LM 48548 A/510/Q	LM 48500
	65,088 2.5625	18,034 0.71	47,3	57	6,2	7 500	11 000	0,25	LM 48548/510/Q	LM 48500

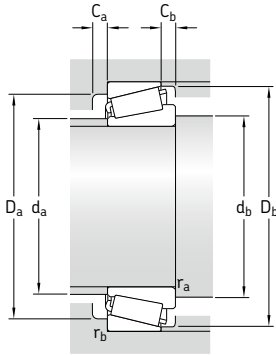

Dimensions				Abutment and fillet dimensions										Calculation factors					
d	d ₁	B	C	r _{1,2}	r _{3,4}	a	d _a	d _b	D _a	D _a	D _b	C _a	C _b	r _a	r _b	e	Y	Y ₀	
mm/in.							mm										-		
26,988 1.0625	10,6	14,732 0.58	10,668 0.42	3,5 0.14	1,3 0.05	11	33	38	43,5	44	47	2	3,5	3,3	1,3	0,37	1,6	0,9	
27,5 1.0827	42	19,355 0.762	15,875 0.625	2,5 0.1	0,8 0.03	14	35	36,5	49	52	54	3	3,5	2,5	0,8	0,33	1,8	1	
28,575 1.125	42	19,355 0.762	15,875 0.625	0,8 0.03	1,5 0.06	14	35	33,5	49	49,5	54	3	3,5	0,8	1,5	0,33	1,8	1	
	42	19,355 0.762	15,875 0.625	3,5 0.14	1,5 0.06	14	35	40	49	49,5	54	3	3,5	3,3	1,5	0,33	1,8	1	
	48,8	21,433 0.8438	16,67 0.6563	1,5 0.06	1,5 0.06	18	38	36	51	56,5	60	3	4,5	1,5	1,5	0,54	1,1	0,6	
	54,2	22,225 0.875	17,462 0.6875	0,8 0.03	3,3 0.13	26	44	33,5	60	61,5	67	3	4,5	0,8	3,1	0,46	1,3	0,7	
29 1.1417	40,8	14,732 0.58	10,668 0.42	3,5 0.14	1,3 0.05	11	34	40	44	44	48	3	3,5	3,3	1,3	0,37	1,6	0,9	
30,162 1.1875	16,6	21,433 0.8438	16,67 0.6563	1,5 0.06	1,5 0.06	18	38	38	51	56,5	60	3	4,5	1,5	1,5	0,54	1,1	0,6	
	52,3	22,28 0.8772	17,462 0.6875	2,3 0.09	1,5 0.06	19	41	39	54	60,5	64	3	4,5	2,3	1,5	0,54	1,1	0,6	
31,75 1.25	45,6	16,77 0.6602	11,811 0.465	3,6 0.14	1,3 0.05	13	38	42	51	53	55	3	4	3,4	1,3	0,4	1,5	0,8	
	45,7	19,05 0.75	14,288 0.5625	4 0.16	2 0.08	13	38	44	54	55	58	4	3,5	3,8	2	0,35	1,7	0,9	
	45,7	19,05 0.75	14,288 0.5625	4 0.16	1,3 0.05	13	38	44	54	55	58	4	3,5	3,8	1,3	0,35	1,7	0,9	
	56,8	27,783 1.0938	23,02 0.9063	1,3 0.05	3,3 0.13	23	42	38	55	62	69	3	6	1,3	3,1	0,54	1,1	0,6	
33,338 1.3125	52,3	22,28 0.8772	17,462 0.6875	0,8 0.03	1,5 0.06	19	41	38,5	54	60,5	64	3	4,5	0,8	1,5	0,54	1,1	0,6	
34,925 1.375	50	18,288 0.72	13,97 0.55	0,8 0.03	1,3 0.05	14	42	40	57	58,5	61	3	4	0,8	1,3	0,37	1,6	0,9	
	50	18,288 0.72	13,97 0.55	3,5 0.14	1,3 0.05	14	42	46	57	58,5	61	3	4	3	1,3	0,37	1,6	0,9	

7.2 Inch single row tapered roller bearings

d 34,925 – 38,1 mm

1.375 – 1.5 in.

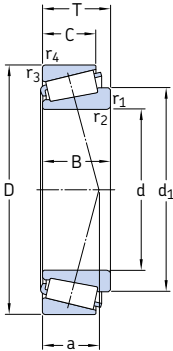

Principal dimensions			Basic load ratings		Fatigue load limit P_u	Speed ratings		Mass	Designation	Series	
d	D	T	dynamic C	static C_0		Reference speed	Limiting speed				
mm/in.			kN		kN	r/min		kg	-	-	
34,925 1.375	69,012	19,845	53,9	67	7,35	7 500	11 000	0,34	14137 A/14276/Q	14000	
	2,717	0,7813									
cont	72,233	25,4	67,1	90	10	6 700	10 000	0,5	HM 88649/2/610/2/QCL7C	HM 88600	
	2,8438	1									
	73,025	23,812									
	2,875	0,9375									
	73,025	26,988									
	2,875	1,0625									
3	76,2	29,37	82,5	100	11,2	6 700	10 000	0,63	31594/31520/Q	31500	
	3	1,1563									
3	76,2	29,37	78,1	106	11,8	6 300	9 500	0,66	HM 89446/2/410/2/QCL7C	HM 89400	
	3	1,1563									
34,988 1.3775	59,131	15,875	33	44	4,5	8 000	12 000	0,17	L 68149/110/Q	L 68100	
	2,328	0,625									
36,512 1.4375	76,2	29,37	78,1	106	11,8	6 300	9 500	0,64	HM 89449/2/410/2/QCL7C	HM 89400	
	3	1,1563									
38,1 1.5	65,088	18,034	42,9	57	6,1	7 500	11 000	0,23	LM 29748/710/Q	LM 29700	
	2,5625	0,71									
	65,088	18,034	42,9	57	6,1	7 500	11 000	0,24	LM 29749/710/Q	LM 29700	
	2,5625	0,71									
	65,088	18,034	42,9	57	6	7 500	11 000	0,24	LM 29749/711/Q	LM 29700	
	2,5625	0,71									
	3	76,2	23,812	74,8	93	10,4	6 700	10 000	0,5	2788/2720/QCL7C	2700
		3	0,9375								
3	79,375	29,37	91,3	110	12,5	6 700	9 500	0,67	3490/3420/QCL7CVQ492	3400	
	3,125	1,1563									
3,25	82,55	29,37	85,8	118	13,4	6 000	8 500	0,78	HM 801346 X/2/310/QVQ523	HM 801300	
	3,25	1,1563									
3,25	82,55	29,37	85,8	118	13,4	6 000	8 500	0,78	HM 801346/310/Q	HM 801300	
	3,25	1,1563									
3,4842	88,5	26,988	101	114	13,2	6 300	9 000	0,83	418/414/Q	415	
	3,4842	1,0625									

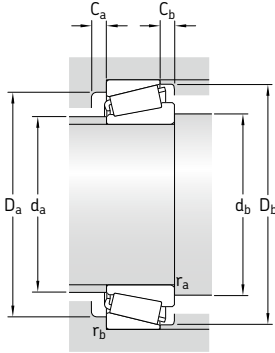

Dimensions				Abutment and fillet dimensions										Calculation factors					
d	d ₁	B	C	r _{1,2}	r _{3,4}	a	d _a	d _b	D _a	D _a	D _b	C _a	C _b	r _a	r _b	e	Y	Y ₀	
mm/in.							mm										-		
34,925 1.375	50,7	19,583	15,875	1,5	1,3	15	43	42	47	61,5	63	3	3,5	1,5	1,3	0,37	1,6	0,9	
cont		0,771	0,625	0,06	0,05														
	56,6	25,4	19,842	2,3	2,3	20	42	44	57	63	68	5	5,5	2,3	2,3	0,54	1,1	0,6	
		1	0,7812	0,09	0,09														
	52,5	24,608	19,05	1,5	0,8	15	44	42	62	66,5	67	5	4,5	1,5	0,8	0,3	2	1,1	
		0,9688	0,75	0,06	0,03														
	52,3	26,975	22,225	3,5	1,5	19	42	46	59	65	67	3	4,5	3,3	1,5	0,37	1,6	0,9	
		1,062	0,875	0,14	0,06														
	23,8	28,575	23,812	1,5	3,3	20	44	42	62	64,5	71	4	5,5	1,5	3,1	0,4	1,5	0,8	
		1,125	0,9375	0,06	0,13														
	59,3	28,575	23,02	3,5	3,3	23	44	46	58	65	72	3	6	3,3	3,1	0,54	1,1	0,6	
		1,125	0,9063	0,14	0,13														
34,988 1.3775	48,4	16,764	11,938	3,5	1,3	13	41	46	52	53	56	3	3,5	3,3	1,3	0,43	1,4	0,8	
		0,66	0,47	0,14	0,05														
36,512 1.4375	59,3	28,575	23,02	3,5	3,3	23	44	48	58	65	72	3	6	3,3	3,1	0,54	1,1	0,6	
		1,125	0,9063	0,14	0,13														
38,1 1.5	51,8	18,288	13,97	2,3	1,3	15	44	47,5	57	58,5	61	2	4	2,3	1,3	0,33	1,8	1	
		0,72	0,55	0,09	0,05														
	51,3	18,288	13,97	2,3	1,3	15	44	47	58	58	61	2	4	2	1,3	0,33	1,8	1	
		0,72	0,55	0,09	0,05														
	51,3	18,288	15,8	2,3	1,3	15	44	47,5	57	58,5	61	2	4	2,3	1,3	0,33	1,8	1	
		0,72	0,622	0,09	0,05														
	54,8	25,654	19,05	3,5	3,3	16	46	49,5	64	65	69	5	4,5	3,3	3,1	0,3	2	1,1	
		1,01	0,75	0,14	0,13														
	57,3	29,771	23,812	3,5	3,3	20	46	49,5	65	68	73	4	5,5	3,3	3,1	0,37	1,6	0,9	
		1,1721	0,9375	0,14	0,13														
	64,1	28,575	23,02	2,3	3,3	24	49	47	64	71	78	4	6	2,3	3,1	0,54	1,1	0,6	
		1,125	0,9063	0,09	0,13														
	64,1	28,575	23,02	0,8	3,3	24	49	43	64	71	78	4	6	0,8	3,1	0,54	1,1	0,6	
		1,125	0,9063	0,03	0,13														
	58,8	29,134	22,276	3,5	1,5	17	49	49,5	73	80,5	78	5	4,5	3,3	1,5	0,26	2,3	1,3	
		1,147	0,877	0,14	0,06														

7.2 Inch single row tapered roller bearings

d **41,275 – 44,45** mm

1.625 – 1.75 in.

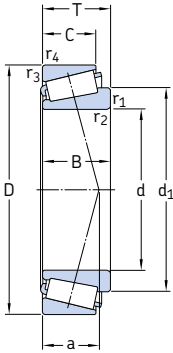

Principal dimensions			Basic load ratings		Fatigue load limit P_u	Speed ratings		Mass	Designation	Series
d	D	T	dynamic C	static C_0		Reference speed	Limiting speed			
mm/in.			kN		kN	r/min		kg	–	–
41,275 1.625	73,431 2,891	19,558 0,77	55	68	7,65	6 700	10 000	0,34	LM 501349/310/Q	LM 501300
	73,431 2,891	21,43 0,8437	55	68	7,65	6 700	10 000	0,36	LM 501349/314/Q	LM 501300
	76,2 3	18,009 0,709	45,7	56	6,1	6 700	9 500	0,34	11163/11300/Q	11000
	76,2 3	18,009 0,709	45,7	56	6,1	9 500	9 500	0,34	11162/11300/Q	11000
	76,2 3	22,225 0,875	68,2	86,5	9,65	6 700	9 500	0,43	24780/24720/Q	24700
	82,55 3,25	26,543 1,045	73,7	91,5	10,6	6 000	9 000	0,62	M 802048/011/QCL7C	M 802000
	88,9 3,5	30,162 1,1875	119	173	20	5 600	8 000	0,9	HM 803146/110/Q	HM 803100
42,875 1.688	82,931 3,265	23,812 0,9375	80,9	106	11,8	6 000	9 000	0,57	25577/2/25520/2/Q	25500
	83,058 3,27	26,998 1,0629	80,9	106	11,8	6 000	9 000	0,57	25577/2/25523/2/Q	25500
44,45 1.75	82,931 3,265	23,812 0,9375	80,9	106	11,8	6 000	9 000	0,57	25580/25520/Q	25500
	83,058 3,27	23,876 0,94	80,9	106	11,8	6 000	9 000	0,57	25580/25522/Q	25500
	83,058 3,27	26,988 1,0625	80,9	106	11,8	6 000	9 000	0,57	25580/25523/Q	25500
	88,9 3,5	30,162 1,1875	95,2	127	14,6	5 600	8 000	0,85	HM 803149/110/Q	HM 803100
	95,25 3,75	30,958 1,2188	88	96,5	11,4	5 000	7 000	0,93	53178/53377/Q	53000
	95,25 3,75	30,958 1,2188	101	122	14	4 800	7 000	1	HM 903249/2/210/2/Q	HM 903200
	104,775 4,125	36,512 1,4375	151	216	23,6	4 500	6 700	1,5	HM 807040/010/QCL7C	HM 807000
	107,95 4,25	36,512 1,4375	151	190	22,8	4 800	7 000	1,7	535/532 X	535
	111,125 4,375	38,1 1,5	151	193	22	4 800	7 000	1,85	535/532 A	535

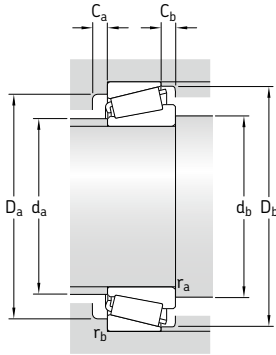

Dimensions				Abutment and fillet dimensions										Calculation factors					
d	d_1	B	C	$r_{1,2}$	$r_{3,4}$	a	d_a	d_b	D_a	D_a	D_b	C_a	C_b	r_a	r_b	e	Y	Y_0	
mm/in.							mm										-		
41,275 1.625	57,8	19,812	14,732	3,5	0,8	16	48	52,5	64	68	69	4	4,5	3,3	0,8	0,4	1,5	0,8	
		<i>0.78</i>	<i>0.58</i>	<i>0.14</i>	<i>0.03</i>														
	57,8	19,812	16,604	3,5	0,8	18	48	52,5	63	68	69	3	4,5	3,3	0,8	0,4	1,5	0,8	
		<i>0.78</i>	<i>0.6537</i>	<i>0.14</i>	<i>0.03</i>														
	58,2	17,384	14,288	0,8	1,5	17	50	46	65	68	71	3	4,5	0,8	1,5	0,48	1,25	0,7	
		<i>0.6844</i>	<i>0.5625</i>	<i>0.03</i>	<i>0.06</i>														
	58,2	17,384	14,288	1,5	1,5	17	50	49	65	68	71	3	4,5	1,5	1,5	0,48	1,25	0,7	
		<i>0.6844</i>	<i>0.5625</i>	<i>0.06</i>	<i>0.06</i>														
	57,7	23,02	17,462	3,5	0,8	17	48	52,5	64	64	71	3	3,5	3,3	0,8	0,4	1,5	0,8	
		<i>0.9063</i>	<i>0.6875</i>	<i>0.14</i>	<i>0.03</i>														
	62,3	25,654	20,193	3,5	3,3	22	50	52,5	66	71	78	4	6	3,3	3,1	0,54	1,1	0,6	
		<i>1.01</i>	<i>0.795</i>	<i>0.14</i>	<i>0.13</i>														
	23	29,37	23,02	3,5	3,3	26	53	52,5	70	78	84	4	7	3	3	0,54	1,1	0,6	
		<i>1.1563</i>	<i>0.9063</i>	<i>0.14</i>	<i>0.13</i>														
42,875 1.688	62,1	25,4	19,05	3,5	0,8	17	53	54	71	77	76	5	4,5	3,3	0,8	0,33	1,8	1	
		<i>1</i>	<i>0.75</i>	<i>0.14</i>	<i>0.03</i>														
	62,1	25,4	22,225	3,5	2,3	20	53	54	70	74	76	3	4,5	3,3	2,3	0,33	1,8	1	
		<i>1</i>	<i>0.875</i>	<i>0.14</i>	<i>0.09</i>														
44,45 1.75	62,1	25,4	19,05	3,5	0,8	17	53	55,5	71	76	76	5	4,5	3,3	0,8	0,33	1,8	1	
		<i>1</i>	<i>0.75</i>	<i>0.14</i>	<i>0.03</i>														
	62,1	25,4	19,114	3,5	2	17	53	55,5	71	74	76	5	4,5	3,3	2	0,33	1,8	1	
		<i>1</i>	<i>0.7525</i>	<i>0.14</i>	<i>0.08</i>														
	62,1	25,4	22,225	3,5	2,3	20	53	55,5	70	73	76	3	4,5	3,3	2,3	0,33	1,8	1	
		<i>1</i>	<i>0.875</i>	<i>0.14</i>	<i>0.09</i>														
	69	29,37	23,02	3,5	3,3	26	53	55,5	70	78	84	4	7	3,3	3,1	0,54	1,1	0,6	
		<i>1.1563</i>	<i>0.9063</i>	<i>0.14</i>	<i>0.13</i>														
	69,3	28,3	20,638	2	2,3	30	53	52,5	72	86	89	4	10	2	2,3	0,75	0,8	0,45	
		<i>1.1142</i>	<i>0.8125</i>	<i>0.08</i>	<i>0.09</i>														
	71,6	28,575	22,225	3,5	0,8	30	53	55,5	71	88	90	4	8,5	3,3	0,8	0,75	0,8	0,45	
		<i>1.125</i>	<i>0.875</i>	<i>0.14</i>	<i>0.03</i>														
	28,5	36,512	28,575	3,5	3,3	28	63	55,5	85	93	100	4	7,5	3,3	3,1	0,48	1,25	0,7	
		<i>1.4375</i>	<i>1.125</i>	<i>0.14</i>	<i>0.13</i>														
	76,5	36,957	28,575	3,5	3,3	24	64	55,5	90	95,5	97	5	7,5	3,3	3,1	0,3	2	1,1	
		<i>1.455</i>	<i>1.125</i>	<i>0.14</i>	<i>0.13</i>														
	77,1	36,957	30,162	3,5	3,3	24	64	55,5	90	95,5	97	5	7,5	3,3	3,1	0,3	2	1,1	
		<i>1.455</i>	<i>1.1875</i>	<i>0.14</i>	<i>0.13</i>														

7.2 Inch single row tapered roller bearings

d 45,237 – 50,8 mm

1.781 – 2 in.

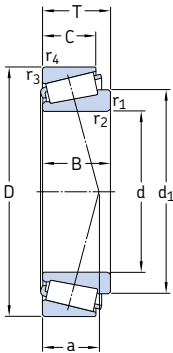

Principal dimensions			Basic load ratings		Fatigue load limit P_u	Speed ratings		Mass	Designation	Series
d	D	T	dynamic C	static C_0		Reference speed	Limiting speed			
mm/in.			kN		kN	r/min		kg	–	–
45,237 1.781	87,312	30,162	102	132	15	6 000	8 500	0,85	3585/3525/Q	3500
	3,4375	1,1875								
	87,312	30,162	102	132	15	6 000	8 500	0,85	3586/3525/Q	3500
	3,4375	1,1875								
45,242 1.7812	73,431	19,558	53,9	75	8,15	6 700	9 500	0,31	LM 102949/910/Q	LM 102900
	2,891	0,77								
	77,788	19,842	53,9	69,5	7,65	6 300	9 000	0,37	LM 603049/011/Q	LM 603000
	3,0625	0,7812								
45,618 1.796	82,931	26,988	80,9	106	11,8	6 000	9 000	0,59	25590/25523/Q	25500
	3,265	1,0625								
	83,058	23,876	80,9	106	11,8	6 000	9 000	0,55	25590/25522/Q	25500
	3,27	0,94								
46,038 1.8125	79,375	17,462	49,5	62	6,8	6 300	9 000	0,33	18690/18620/Q	18600
	3,125	0,6875								
	85	20,638	70,4	81,5	9,3	6 000	8 500	0,49	359 S/354 X/Q	355
	3,3465	0,8125								
47,625 1.875	88,9	20,638	76,5	91,5	10,4	5 600	8 000	0,55	369 S/2/362 A/2/Q	365
	3,5	0,8125								
	95,25	30,162	108	146	17,3	5 000	7 500	0,95	HM 804846/2/810/2/Q	HM 804800
	3,75	1,1875								
	101,6	34,925	151	190	22,8	5 000	7 500	1,25	528 R/522	525
	4	1,375								
49,212 1.9375	114,3	44,45	183	224	25	4 500	6 700	2,2	65390/65320/QCL7C	65300
	4,5	1,75								
50,8 2	88,9	20,638	76,5	91,5	10,4	5 600	8 000	0,5	368 A/362 A/Q	365
	3,5	0,8125								
	90	25	76,5	91,5	10,4	5 600	8 000	0,58	368 A/362 X/Q	365
	3,5433	0,9843								
	93,264	30,162	110	146	17	5 300	7 500	0,87	3780/3720/Q	3700
	3,6718	1,1875								
	104,775	36,512	145	204	22,4	4 500	6 700	1,5	HM 807046/010/QCL7C	HM 807000
	4,125	1,4375								
	104,775	39,688	187	285	32	4 800	7 000	1,65	4580/2/4535/2/Q	4500
	4,125	1,5625								

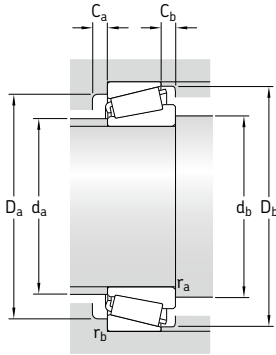

Dimensions						Abutment and fillet dimensions										Calculation factors		
d	d ₁	B	C	r _{1,2}	r _{3,4}	a	d _a	d _b	D _a	D _a	D _b	C _a	C _b	r _a	r _b	e	Y	Y ₀
mm/in.						mm										-		
45,237 1.781	63,1	30,886 1.216	23,812 0.9375	3,5 0.14	3,3 0.13	20	53	49	73	76	80	4	6	1,5	3	0,31	1,9	1,1
	63,1	30,886 1,216	23,812 0,9375	3,5 0,14	3,3 0,13	20	53	57	73	76	80	4	6	3,3	3,1	0,31	1,9	1,1
45,242 1.7812	59,4	19,812 0.78	15,748 0.62	3,5 0.14	0,8 0.03	15	52	57	66	68	70	3	3,5	3,3	0,8	0,3	2	1,1
	62	19,842 0.7812	15,08 0.5937	3,5 0.14	0,8 0.03	17	52	57	68	72	74	4	4,5	3,3	0,8	0,43	1,4	0,8
45,618 1.796	62,2	25,4 1	22,225 0.875	3,5 0.14	2,3 0.09	20	53	57	71	74	76	3	4,5	3,3	2,3	0,33	1,8	1
	62,2	25,4 1	19,114 0.7525	3,5 0.14	2 0.08	17	53	57	71	74,5	76	5	4,5	3,3	2	0,33	1,8	1
46,038 1.8125	60,3	17,462 0.6875	13,495 0.5313	2,8 0.11	1,5 0.06	15	53	56,5	69	72	73	3	3,5	2,6	1,5	0,37	1,6	0,9
	62,4	21,692 0.854	17,462 0.6875	2,3 0.09	1,5 0.06	16	55	55	76	77,5	80	3	3	2,3	1,5	0,31	1,9	1,1
47,625 1.875	66,2	22,28 0.8772	16,56 0.652	2,3 0.09	1,3 0.05	16	55	56,5	76	82,5	80	3	3	2,3	1,3	0,31	1,9	1,1
	73,6	29,37 1.1563	23,02 0.9063	3,5 0.14	3,3 0.13	26	58	59	76	84	90	5	7	3,3	3,1	0,54	1,1	0,6
	72,9	36,068 1.42	26,988 1.0625	8 0.31	3,3 0.13	22	54	71,5	87	90	94	6	7,5	7	3,1	0,28	2,1	1,1
49,212 1.9375	79,3	44,45 1.75	34,925 1.375	3,5 0.14	3,3 0.13	31	60	60,5	89	103	105	5	9,5	3,3	3,1	0,43	1,4	0,8
50,8 2	66,2	22,225 0.875	16,513 0.6501	3,5 0.14	1,3 0.05	16	58	62	80	82,5	83	4	4	3,3	1,3	0,31	1,9	1,1
	66,2	22,225 0.875	20 0.7874	3,5 0.14	2 0.08	21	58	62	78	81,5	83	3	5	3,3	2	0,31	1,9	1,1
	71,2	30,302 1.193	23,812 0.9375	3,5 0.14	3,3 0.13	22	60	62	80	84,5	87	3	5	3,3	3,1	0,33	1,8	1
	81,5	36,512 1.4375	28,575 1.125	3,5 0.14	3,3 0.13	29	63	62	85	92,5	100	6	7,5	3,3	3,1	0,48	1,25	0,7
	79,5	40,157 1.581	33,338 1.3125	3,5 0.14	3,3 0.13	27	65	62	87	92,5	98	5	6	3,3	3,1	0,33	1,8	1

7.2 Inch single row tapered roller bearings

d 53,975 – 65,088 mm

2.125 – 2.5625 in.

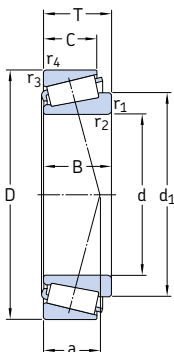

Principal dimensions			Basic load ratings		Fatigue load limit P_u	Speed ratings		Mass	Designation	Series
d	D	T	dynamic C	static C_0		Reference speed	Limiting speed			
mm/in.			kN		kN	r/min		kg	–	–
53,975 2.125	88,9 3,5	19,05 0,75	58,3	78	9	5 300	8 000	0,44	LM 806649/610/Q	LM 806600
	95,25 3,75	27,783 1,0938	105	137	16	5 300	7 500	0,8	33895/33821/Q	33800
	95,25 3,75	27,783 1,0938	105	137	16	5 300	7 500	0,81	33895/33822/Q	33800
	107,95 4,25	36,512 1,4375	151	190	22,8	4 800	7 000	1,45	539/532 X	535
	111,125 4,375	38,1 1,5	151	193	22,8	4 800	7 000	1,55	539/532 A	535
	123,825 4,875	36,512 1,4375	142	160	19,6	4 000	5 600	2	72212/2/72487/2/Q	72000
57,15 2.25	96,838 3,8125	21 0,8268	80,9	102	11,6	5 000	7 500	0,59	387 A/382 A/Q	385
	104,775 4,125	30,162 1,1875	121	160	18,6	4 800	7 000	1,05	462/453 X	455
	112,712 4,4375	30,162 1,1875	142	204	23,6	4 300	6 300	1,35	39581/39520/Q	39500
	119,985 4,7238	32,75 1,2894	142	204	23,6	4 300	6 300	1,75	39580/39528/Q	39500
	119,985 4,7238	32,75 1,2894	142	204	23,6	4 300	6 300	1,75	39581/39528/Q	39500
60,325 2.375	130,175 5,125	36,512 1,4375	151	180	22,4	3 600	5 000	2,1	HM 911245/W/210/QV001	HM 911200
61,912 2.4375	146,05 5,75	41,275 1,625	198	236	29	3 200	4 500	3,2	H 913842/810/QCL7C	H 913800
	146,05 5,75	41,275 1,625	198	236	29	3 200	4 500	3,15	H 913843/810/QCL7C	H 913800
63,5 2.5	112,712 4,4375	30,162 1,1875	123	183	21,2	4 300	6 300	1,25	3982/3920	3900
65,088 2.5625	135,755 5,3447	53,975 2,125	286	400	46,5	3 800	5 600	3,7	6379/K-6320/Q	6300

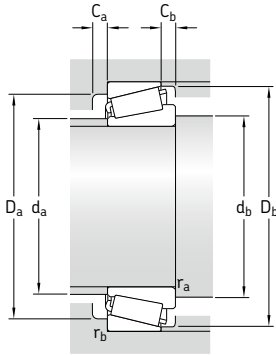

Dimensions						Abutment and fillet dimensions										Calculation factors		
d	d ₁	B	C	r _{1,2}	r _{3,4}	a	d _a	d _b	D _a	D _a	D _b	C _a	C _b	r _a	r _b	e	Y	Y ₀
mm/in.						mm										-		
53,975 2.125	72,1	19,05 0.75	13,492 0.5312	2,3 0.09	2 0.08	21	62	64	78	79,5	84	4	5,5	2,3	2	0,54	1,1	0,6
	72,5	28,575 1.125	22,225 0.875	1,5 0.06	2,3 0.09	20	61	61,5	83	88	90	6	6,5	1,5	2,3	0,33	1,8	1
	72,5	28,575 1.125	22,225 0.875	1,5 0.06	0,8 0.03	20	61	61,5	83	88	90	6	6,5	1,5	0,8	0,33	1,8	1
	77,1	36,957 1.455	28,575 1.125	3,5 0.14	3,3 0.13	24	64	65,5	90	95,5	97	5	7,5	3,3	3,1	0,3	2	1,1
	77,1	36,957 1.455	30,162 1.1875	3,5 0.14	3,3 0.13	24	64	65,5	90	95,5	97	5	7,5	3,3	3,1	0,3	2	1,1
	87,4	32,791 1.291	25,4 1	3,5 0.14	3,3 0.13	36	68	65,5	93	113	114	5	11	3,3	3,1	0,75	0,8	0,45
57,15 2.25	74,1	21,946 0.864	15,875 0.625	3,5 0.14	0,8 0.03	17	65	68,5	87	91,5	91	5	5	3,3	0,8	0,35	1,7	0,9
	78,9	29,317 1.1542	24,605 0.9687	2,3 0.09	3,3 0.13	24	68	67,5	91	93,5	98	4	5,5	2,3	3,1	0,33	1,8	1
	88,3	30,213 1.1895	23,812 0.9375	8 0.31	3,3 0.13	23	76	81	100	102	107	5	6	7	3,1	0,33	1,8	1
	88,3	30,213 1.1895	27 1.063	3,5 0.14	0,8 0.03	25	76	68,5	100	114	107	5	6	3,3	0,8	0,33	1,8	1
	88,3	30,213 1.1895	27 1.063	8 0.31	0,8 0.03	25	76	81	100	114	107	5	6	7	0,8	0,33	1,8	1
60,325 2.375	97,2	33,39 1.3146	23,812 0.9375	5 0.2	3,3 0.13	40	74	76	102	119	124	4	12,5	4,6	3,1	0,83	0,72	0,4
61,912 2.4375	109	39,688 1.5625	25,4 1	3,5 0.14	3,3 0.13	44	83	73,5	116	135	138	6	15,5	3,3	3,1	0,79	0,76	0,4
	109	39,688 1.5625	25,4 1	7 0.28	3,3 0.13	44	83	83	116	135	138	6	15,5	6,6	3,1	0,79	0,76	0,4
63,5 2.5	87,8	30,1 1.185	23,812 0.9375	3,5 0.14	3,3 0.13	25	75	75	96	101	105	4	6	3,3	3,1	0,4	1,5	0,8
65,088 2.5625	97,5	56,06 2.2071	44,45 1.75	3,5 0.14	3,3 0.13	34	78	76,5	110	124	125	7	9,5	3,3	3,1	0,33	1,8	1

7.2 Inch single row tapered roller bearings

d 66,675 – 92,075 mm

2.625 – 3.625 in.

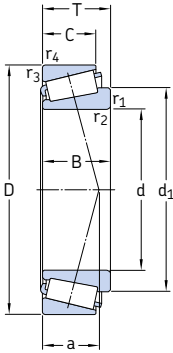

Principal dimensions			Basic load ratings		Fatigue load limit P_u	Speed ratings		Mass	Designation	Series
d	D	T	dynamic C	static C_0		Reference speed	Limiting speed			
mm/in.			kN		kN	r/min		kg	–	–
66,675 2.625	112,712 4,4375	30,162 1.1875	142	204	23,6	4 300	6 300	1,15	39590/39520/Q	39500
	112,712 4,4375	30,162 1.1875	123	183	21,2	4 300	6 300	1,15	3984/2/3920/2/Q	3900
	119,985 4,7238	32,75 1.2894	142	204	23,6	4 300	6 300	1,2	39590/39528/Q	39500
	135,755 5,3447	53,975 2.125	286	400	45,5	3 800	5 600	3,65	6386/K-6320/Q	6300
69,85 2.75	120 4,7244	32,545 1.2813	154	228	26,5	4 000	6 000	1,5	47487/47420 A/Q	47400
	127 5	36,512 1.4375	176	255	29	3 800	5 600	1,9	566/563/Q	565
73,025 2.875	127 5	36,512 1.4375	176	255	30,5	3 800	5 600	1,8	567/563	565
76,2 3	109,538 4,3125	19,05 0.75	58,3	102	11	4 000	6 000	0,6	L 814749/710/QCL7C	L 814700
	127 5	30,163 1.1875	138	204	24	3 800	5 300	1,45	42687/42620	42600
	133,35 5,25	33,338 1.3125	165	260	30	3 400	5 000	1,95	47678/47620/Q	47600
	139,992 5,5115	36,512 1.4375	187	280	32,5	3 400	5 000	2,45	575/572/Q	575
	161,925 6,375	49,212 1.9375	260	335	38	2 800	4 000	4,4	9285/9220/CL7C	9200
77,788 3.0625	127 5	30,163 1.1875	138	204	24	3 800	5 300	1,45	42690/42620	42600
82,55 3.25	139,992 5,5115	36,512 1.4375	187	280	32,5	3 400	5 000	2,2	580/572/Q	575
92,075 3.625	152,4 6	39,688 1.5625	194	305	34,5	3 000	4 500	2,7	598/592 A/Q	595

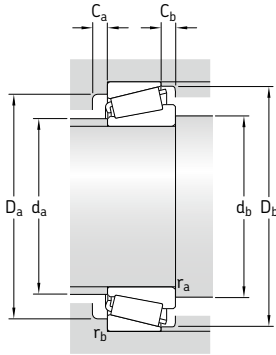

Dimensions						Abutment and fillet dimensions										Calculation factors		
d	d ₁	B	C	r _{1,2}	r _{3,4}	a	d _a	d _b	D _a	D _a	D _b	C _a	C _b	r _a	r _b	e	Y	Y ₀
mm/in.						mm										-		
66,675 2.625	88,3	30,162 1.1875	23,812 0.9375	3,5 0.14	3,3 0.13	23	76	78,5	100	101	107	5	6	3,3	3,1	0,33	1,8	1
	87,9	30,048 1.183	23,812 0.9375	3,5 0.14	3,3 0.13	25	75	78,5	96	101	105	4	6	3,3	3,1	0,4	1,5	0,8
	88,3	30,162 1.1875	27 1.063	3,5 0.14	0,8 0.03	25	76	78,5	100	112	107	5	6	3,3	0,8	0,33	1,8	1
	97,5	56,06 2.2071	44,45 1.75	4,3 0.17	3,3 0.13	34	78	80,5	110	124	125	7	9,5	3,9	3,1	0,33	1,88	1
69,85 2.75	94,3	32,596 1.2833	26,246 1.0333	3,5 0.14	0,5 0.02	25	81	82	105	117	113	6	6	3	0,5	0,35	1,7	0,9
	97,6	36,17 1.424	28,575 1.125	3,5 0.14	3,3 0.13	28	83	82	109	114	119	5	7,5	3,3	3,1	0,37	1,6	0,9
73,025 2.875	97,6	36,17 1.424	28,575 1.125	3,5 0.14	3,3 0.13	28	83	85	109	114	119	5	7,5	3,3	3,1	0,37	1,6	0,9
76,2 3	94,4	19,05 0.75	15,083 0.5938	1,5 0.06	1,5 0.06	24	85	85	98	100,5	105	3,5	1,5	1,5	1,5	0,5	1,2	0,7
	101	31 1.2205	22,225 0.875	3,5 0.14	3,3 0.13	27	88	89,5	112	114	120	5	7,5	3,3	3,1	0,43	1,4	0,8
	107	33,338 1.3125	26,195 1.0313	6,4 0.25	3,3 0.13	29	93	96	117	120,5	126	5	7	6	3,1	0,4	1,5	0,8
	109	36,098 1.4212	28,575 1.125	3,5 0.14	3,3 0.13	31	94	89,5	120	127	131	5	7,5	3,3	3,1	0,4	1,5	0,8
122	46,038 1.8125	31,75 1.25	3,5 0.14	3,3 0.13	47	93	90	128	148,5	153	7	17	3,3	3,1	0,72	0,84	0,45	
77,788 3.0625	101	31 1.2205	22,225 0.875	3,5 0.14	3,3 0.13	27	88	89,5	112	114	120	5	7,5	3	3	0,43	1,4	0,8
82,55 3.25	109	36,098 1.4212	28,575 1.125	3,5 0.14	3,3 0.13	31	94	94,5	120	127	131	5	7,5	3,3	3,1	0,4	1,5	0,8
92,075 3.625	121	36,322 1.43	30,162 1.1875	3,5 0.14	3,3 0.13	37	101	106	128	141	141	4	9,5	3,3	3,1	0,44	1,35	0,8

7.2 Inch single row tapered roller bearings

d 95,25 – 179,934 mm

3.75 – 7.084 in.

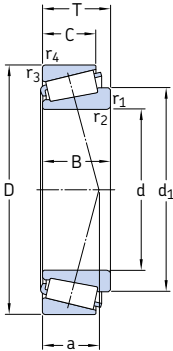

Principal dimensions			Basic load ratings		Fatigue load limit P_u	Speed ratings		Mass	Designation	Series
d	D	T	dynamic C	static C_0		Reference speed	Limiting speed			
mm/in.			kN		kN	r/min		kg	-	-
95,25 3.75	152,4 6	39,688 1.5625	194	305	34,5	3 000	4 500	2,55	594/592 A/Q	595
	168,275 6.625	41,275 1.625	233	365	39	2 800	4 000	3,75	683/672/Q	675
101,6 4	168,275 6.625	41,275 1.625	233	365	39	2 800	4 000	3,45	687/672/Q	675
107,95 4.25	158,75 6.25	23,02 0.9063	101	163	18,3	2 800	4 300	1,4	37425/2/37625/2/Q	37000
114,3 4.5	177,8 7	41,275 1.625	251	415	42,5	2 600	3 800	3,6	64450/64700	64000
	180,975 7.125	34,925 1.375	183	280	30	2 600	3 800	2,95	68450/68712	68000
127 5	196,85 7.75	46,038 1.8125	319	585	60	2 200	3 400	5,15	67388/67322	67300
133,35 5.25	177,008 6.9688	25,4 1	134	280	28	2 400	3 600	1,75	L 327249/210	L 327200
	196,85 7.75	46,038 1.8125	319	585	60	2 200	3 400	4,65	67391/67322	67300
149,225 5.875	236,538 9.3125	57,15 2.25	512	850	86,5	1 900	2 800	9,05	HM 231148/110	HM 231100
152,4 6	222,25 8.75	46,83 1.8437	330	630	62	2 000	3 000	5,85	M 231649/610/VQ051	M 231600
158,75 6.25	205,583 8.0938	23,812 0.9375	138	280	27	2 000	3 000	1,9	L 432348/310	L 432300
177,8 7	227,012 8.9375	30,162 1.1875	187	425	40	1 800	2 800	2,95	36990/36920	36900
178,595 7.0313	265,112 10.4375	51,595 2.0313	495	880	85	1 700	2 400	9,55	M 336948/912	M 336900
179,934 7.084	265,112 10.4375	51,595 2.0313	495	880	85	1 700	2 400	9,4	M 336949/912	M 336900

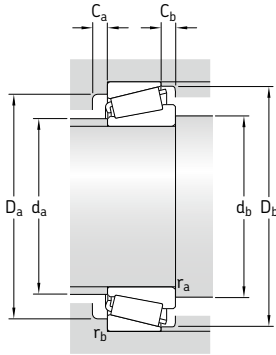

Dimensions				Abutment and fillet dimensions										Calculation factors					
d	d ₁	B	C	r _{1,2}	r _{3,4}	a	d _a	d _b	D _a	D _a	D _b	C _a	C _b	r _a	r _b	e	Y	Y ₀	
mm/in.							mm										-		
95,25 3.75	121	36,322 1,43	30,162 1.1875	3,5 0.14	3,3 0.13	37	104	107	128	139	141	4	9,5	3,3	3,1	0,44	1,35	0,8	
	133	41,275 1,625	30,162 1.1875	3,5 0.14	3,3 0.13	38	114	107	143	154,5	157	6	11	3,3	3,1	0,48	1,25	0,7	
101,6 4	133	41,275 1,625	30,162 1.1875	3,5 0.14	3,3 0.13	38	114	113	143	157	157	6	11	3,3	3,1	0,48	1,25	0,7	
107,95 4.25	132	21,49 0,8461	15,93 0.6272	3,5 0.14	3,3 0.13	37	120	121	140	145	149	4	7	3,3	3,1	0,6	1	0,6	
114,3 4.5	146	41,275 1,625	30,162 1.1875	3,5 0.14	3,3 0.13	42	126	127	155	166	171	6	11	3,3	3,1	0,52	1,15	0,6	
	144	31,75 1,25	25,4 1	3,5 0.14	3,3 0.13	40	129	127	158	170	170	4	9,5	3,3	3,1	0,5	1,2	0,7	
127 5	164	46,038 1,8125	38,1 1,5	3,5 0.14	3,3 0.13	39	146	140	177	185	189	7	7,5	3,3	3,1	0,35	1,7	0,9	
133,35 5.25	155	26,195 1,0313	20,638 0.8125	1,5 0.06	1,5 0.06	29	145	141	165	188	170	5	4,5	1,5	1,5	0,35	1,7	0,9	
	164	46,038 1,8125	38,1 1,5	8 0.31	3,3 0.13	39	146	161	177	185	189	7	7,5	7	3,1	0,35	1,7	0,9	
149,225 5.875	187	56,642 2,23	44,45 1,75	6,4 0.25	3,3 0.13	45	166	171	210	225	223	9	12,5	6	3,1	0,31	1,9	1,1	
152,4 6	186	46,83 1,8437	34,925 1,375	3,5 0.14	1,5 0.06	40	169	165	200	214	210	7	11,5	3,3	1,5	0,33	1,8	1	
158,75 6.25	182	23,812 0,9375	18,258 0.7188	4,8 0.19	1,5 0.06	33	172	175	194	197	197	5	5,5	4,4	1,5	0,35	1,7	0,9	
177,8 7	203	30,162 1,1875	23,02 0.9063	1,5 0.06	1,5 0.06	43	190	186	212	219	220	5	7	1,5	1,5	0,44	1,35	0,8	
178,595 7.0313	216	57,15 2,25	38,895 1.5313	3,3 0.13	3,3 0.13	47	196	191	240	253	251	9	12,5	3,1	3,1	0,33	1,8	1	
179,934 7.084	216	57,23 2.2531	38,895 1.5313	3,3 0.13	3,3 0.13	47	196	193	240	253	251	9	12,5	3,1	3,1	0,33	1,8	1	

7.2 Inch single row tapered roller bearings

d 187,325 – 257,175 mm

7.375 – 10.125 in.

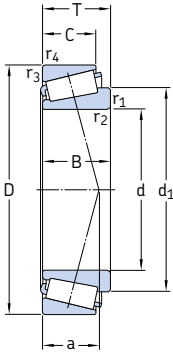

Principal dimensions			Basic load ratings		Fatigue load limit P_u	Speed ratings		Mass	Designation	Series
d	D	T	dynamic C	static C_0		Reference speed	Limiting speed			
mm/in.			kN		kN	r/min		kg	-	-
187,325 7.375	282,575 11.125	50,8 2	402	695	67	1 600	2 200	9,95	87737/87111	87000
190,475 7.5	279,4 11	52,388 2.0625	523	980	93	1 600	2 200	9,5	M 239449/410	M 239400
190,5 7.5	282,575 11.125	50,8 2	402	695	67	1 600	2 200	9,55	87750/87111	87000
191,237 7.529	279,4 11	52,388 2.0625	523	980	95	1 600	2 200	9,2	M 239448 A/410	M 239400
196,85 7.75	241,3 9,5	23,812 0.9375	154	315	29	1 700	2 600	2,1	LL 639249/210	LL 639200
	257,175 10.125	39,688 1.5625	275	655	58,5	1 600	2 400	5,35	LM 739749/710/VE174	LM 739700
200,025 7.875	276,225 10.875	42,862 1.6875	391	780	72	1 500	2 200	7,7	LM 241147/110/VQ051	LM 241100
203,987 8.031	276,225 10.875	42,862 1.6875	391	780	72	1 500	2 200	7,2	LM 241148/110/VQ051	LM 241100
206,375 8.125	282,575 11.125	46,038 1.8125	224	415	38	1 500	2 200	8,6	67985/67920/HA3VQ117	67900
216,408 8.52	285,75 11.25	46,038 1.8125	380	850	76,5	1 500	2 200	7,9	LM 742747/710	LM 742700
216,713 8.532	285,75 11.25	46,038 1.8125	380	850	76,5	1 500	2 200	7,85	LM 742747 A/710	LM 742700
231,775 9.125	300,038 11.8125	33,338 1.3125	216	425	39	1 400	2 000	5,3	544091/2B/118 A/2B	544000
255,6 10.063	342,9 13.5	57,15 2.25	660	1 400	125	1 200	1 800	15	M 349547/510	M 349500
257,175 10.125	342,9 13.5	57,15 2.25	380	680	61	1 200	1 800	14	M 349549/510/VE174	M 349500
	358,775 14.125	71,438 2.8125	842	1 760	156	1 200	1 700	21,5	M 249747/710	M 249700

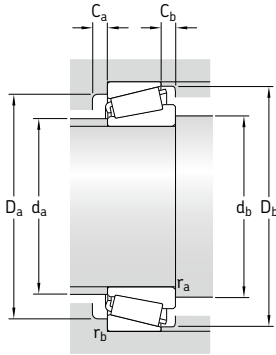

Dimensions						Abutment and fillet dimensions										Calculation factors		
d	d ₁	B	C	r _{1,2}	r _{3,4}	a	d _a	d _b	D _a	D _a	D _b	C _a	C _b	r _a	r _b	e	Y	Y ₀
mm/in.						mm										-		
187,325 7.375	232	47,625 1.875	36,512 1.4375	3,5 0.14	3,3 0.13	55	213	201	253	271	267	6	14	3,3	3,1	0,43	1,4	0,8
190,475 7.5	232	57,15 2.25	41,33 1.6272	3,3 0.13	3,3 0.13	49	211	203	254	265	266	9	11	3,1	3,1	0,35	1,7	0,9
190,5 7.5	232	47,625 1.875	36,512 1.4375	3,5 0.14	3,3 0.13	55	213	205	253	268	267	6	14	3,3	3,1	0,43	1,4	0,8
191,237 7.529	232	58,81 2.3153	41,33 1.6272	3,3 0.13	3,3 0.13	49	211	204	254	265	266	9	11	3,1	3,1	0,33	1,8	1
196,85 7.75	217	23,017 0.9062	17,462 0.6875	1,5 0.06	1,5 0.06	41	207	204	232	233	235	5	6	1,5	1,5	0,43	1,4	0,8
	229	39,688 1.5625	30,162 1.1875	3,5 0.14	3,3 0.13	50	236	210	236	245	247	8	9,5	3,3	3,1	0,44	1,35	0,8
200,025 7.875	236	46,038 1.8125	34,133 1.3438	3,5 0.14	3,3 0.13	45	220	213	257	261	265	6	8,5	3,3	3,1	0,31	1,9	1,1
203,987 8.031	236	46,038 1.8125	34,133 1.3438	3,5 0.14	3,3 0.13	45	220	217	257	261	265	6	8,5	3,3	3,1	0,31	1,9	1,1
206,375 8.125	36,5	46,038 1.8125	36,512 1.4375	3,5 0.14	3,3 0.13	62	222	220	254	268	272	8	9,5	3,3	3,1	0,5	1,2	0,7
216,408 8.52	253	49,212 1.9375	34,925 1.375	3,5 0.14	3,3 0.13	60	230	230	261	271	277	7	11	3,3	3,1	0,48	1,25	0,7
216,713 8.532	253	49,212 1.9375	34,925 1.375	3,5 0.14	3,3 0.13	60	230	230	261	271	277	7	11	3,3	3,1	0,48	1,25	0,7
231,775 9.125	260	31,75 1.25	23,812 0.9375	3,5 0.14	3,3 0.13	49	248	246	278	284	284	5	9,5	3,3	3,1	0,4	1,5	0,8
255,6 10.063	296	63,5 2.5	44,45 1.75	1,5 0.06	3,3 0.13	60	274	267	318	328	331	9	12,5	1,5	3	0,35	1,7	0,9
257,175 10.125	44,4	57,15 2.25	44,5 1.752	6,4 0.25	3,3 0.13	60	274	289	318	328	331	9	12,5	6	3	0,35	1,7	0,9
	303	76,2 3	53,975 2.125	1,5 0.06	3,3 0.13	64	276	269	326	343	343	11	17	1,5	3	0,33	1,8	1

7.2 Inch single row tapered roller bearings

d 263,525 – 558,8 mm

10.375 – 22 in.

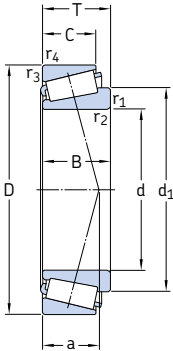

Principal dimensions			Basic load ratings		Fatigue load limit P_u	Speed ratings		Mass	Designation	Series
d	D	T	dynamic C	static C_0		Reference speed	Limiting speed			
mm/in.			kN		kN	r/min		kg	-	-
263,525 10.375	325,438 12.8125	28,575 1.125	220	550	48	1 300	1 800	5,3	38880/38820	38800
292,1 11.5	374,65 14.75	47,625 1.875	501	1 140	98	1 100	1 600	12,5	L 555249/210	L 555200
304,8 12	393,7 15.5	50,8 2	319	610	52	1 000	1 500	14,5	L 357049/010/VE174	L 357000
343,154 13.51	450,85 17.75	66,675 2.625	935	2 200	180	900	1 300	28	LM 361649 A/610	LM 361600
346,075 13.625	488,95 19.25	95,25 3.75	1 420	3 150	255	850	1 300	55	HM 262749/710	HM 262700
381 15	479,425 18.875	49,213 1.9375	594	1 500	120	800	1 200	20	L 865547/512	L 865500
384,175 15.125	546,1 21.5	104,775 4.125	1 870	4 150	320	750	1 100	77	HM 266449/410	HM 266400
403,225 15.875	460,375 18.125	28,575 1.125	246	765	58,5	800	1 200	6,7	LL 566848/810/HA1	LL 566800
406,4 16	549,275 21.625	85,725 3.375	1 380	3 050	236	700	1 000	53,5	LM 567949/910/HA1	LM 567900
457,2 18	603,25 23.75	85,725 3.375	1 450	3 400	265	630	950	61,5	LM 770949/910	LM 770900
488,95 19.25	634,873 24.995	84,138 3.3125	1 450	3 650	265	600	850	63,5	LM 772748/710/HA1	LM 772700
498,475 19.625	634,873 24.995	80,962 3.1875	1 470	3 650	270	600	850	59,5	EE 243196/243250/HA2	243000
558,8 22	736,6 29	88,108 3.4688	1 830	4 150	305	500	750	92,5	EE 843220/290	843000
	736,6 29	104,775 4.125	2 330	5 700	405	500	750	115	LM 377449/410	LM 377400

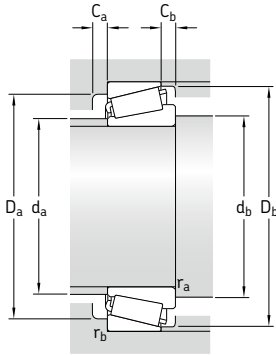

Dimensions				Abutment and fillet dimensions										Calculation factors					
d	d ₁	B	C	r _{1,2}	r _{3,4}	a	d _a	d _b	D _a	D _a	D _b	C _a	C _b	r _a	r _b	e	Y	Y ₀	
mm/in.							mm										-		
263,525 10.375	293	28,575 1.125	25,4 1	1,5 0.06	1,5 0.06	49	282	275	307	315	313	4	3	1,5	1,5	0,37	1,6	0,9	
292,1 11.5	330	47,625 1.875	34,925 1.375	3,5 0.14	3,3 0.13	65	311	308	350	359	361	8	12,5	3,3	3,1	0,4	1,5	0,8	
304,8 12	38,1	50,8 2	38,18 1.5031	6,4 0.25	3,3 0.13	64	328	337	368	378	379	7	12,5	6	3,1	0,35	1,7	0,9	
343,154 13.51	393	66,675 2.625	52,388 2.0625	8,5 0.33	3,5 0.14	75	365	385	417	433	434	12	14	7,5	3,3	0,35	1,7	0,9	
346,075 13.625	413	95,25 3.75	74,612 2.9375	6,4 0.25	3,3 0.13	88	379	378	442	472	467	12	21	6	3,1	0,33	1,8	1	
381 15	430	47,625 1.875	34,925 1.375	6,4 0.25	3,3 0.13	92	406	413	448	462	463	9	14	6	3,1	0,5	1,2	0,7	
384,175 15.125	457	104,775 4.125	82,55 3.25	6,4 0.25	6,4 0.25	96	418	416	492	514	520	15	22	6	6	0,33	1,8	1	
403,225 15.875	430	28,575 1.125	20,638 0.8125	3,5 0.14	3,3 0.13	70	417	420	445	443	448	6	7,5	3,3	3,1	0,4	1,5	0,8	
406,4 16	473	84,138 3.3125	61,692 2.4288	6,4 0.25	3,3 0.13	100	434	438	502	532	526	13	23,5	6	3,1	0,4	1,5	0,8	
457,2 18	525	84,138 3.3125	60,325 2.375	6,4 0.25	3,3 0.13	115	486	489	553	586	580	13	25	6	3,1	0,46	1,3	0,7	
488,95 19.25	560	84,138 3.3125	61,912 2.4375	6,4 0.25	3,3 0.13	124	519	520	584	618	613	13	22	6	3,1	0,48	1,25	0,7	
498,475 19.625	556	80,962 3.1875	63,5 2.5	6,4 0.25	3,3 0.13	98	522	530	590	618	610	14	17	6	3,1	0,35	1,7	0,9	
558,8 22	637	88,108 3.4688	63,5 2.5	6,4 0.25	6,4 0.25	111	600	590	689	704	707	13	24,5	6	6	0,35	1,7	0,9	
	640	104,775 4.125	80,962 3.1875	6,4 0.25	6,4 0.25	130	595	590	680	704	707	17	23,5	6	6	0,35	1,7	0,9	

7.2 Inch single row tapered roller bearings

d 609,6 – 838,2 mm

24 – 33 in.

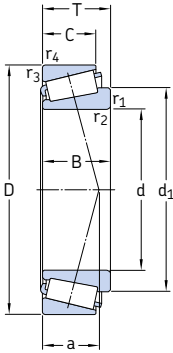

Principal dimensions			Basic load ratings		Fatigue load limit P_u	Speed ratings		Mass	Designation	Series
d	D	T	dynamic C	static C_0		Refer- ence speed	Limit- ing speed			
mm/in.			kN		kN	r/min		kg	-	-
609,6 24	787,4 31	93,662 3.6875	2 160	5 300	380	450	670	110	EE 649240/310	649000
749,3 29,5	990,6 39	159,5 6.2795	4 570	12 000	750	340	500	330	LM 283649/610/HA1	LM 283600
760 29,9212	889 35	69,85 2.75	1 230	3 800	255	560	560	67,5	LL 483448/418	LL 483400
	889 35	88,9 3.5	1 870	5 850	380	360	530	94	L 183448/410	L 183400
762 30	889 35	69,85 2.75	1 230	3 800	255	380	560	66,5	LL 483449/418	LL 483400
	889 35	88,9 3.5	1 870	5 850	380	360	530	94	L 183449/410/HB1	L 183400
838,2 33	1041,4 41	93,662 3.6875	1 900	4 800	320	320	460	160	EE 763330/410	763000

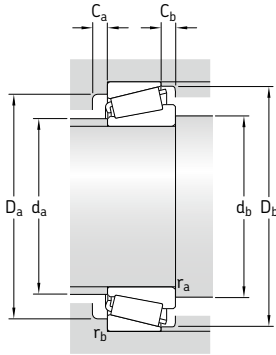

Dimensions				Abutment and fillet dimensions										Calculation factors					
d	d_1	B	C	$r_{1,2}$	$r_{3,4}$	a	d_a	d_b	D_a	D_a	D_b	C_a	C_b	r_a	r_b	e	Y	Y_0	
mm/in.							mm										-		
609,6 24	687	93,662 3.6875	69,85 2.75	6,4 0.25	6,4 0.25	125	643	642	732	755	755	17	23,5	6	6	0,37	1,6	0,9	
749,3 29.5	858	160,338 6.3125	123 4.8425	6,4 0.25	6,4 0.25	165	793	781	910	958	953	22	36,6	6	6	0,33	1,8	1	
760 29.9212	819	69,85 2.75	50,8 2.	3,3 0.13	3,3 0.13	132	785	777	844	872	858	13	19	3,1	3,1	0,37	1,6	0,9	
	823	88,9 3.5	72 2.8346	3,3 0.13	3,3 0.13	123	785	777	854	872	872	16	16,5	3,1	3,1	0,3	2	1,1	
762 29.9999	819	69,85 2.75	50,8 2.	3,3 0.13	3,3 0.13	132	785	779	844	872	858	13	19	3,1	3,1	0,37	1,6	0,9	
	821	88,9 3.5	72 2.8346	3,3 0.13	3,3 0.13	123	785	779	854	872	872	16	16,5	3,1	3,1	0,3	2	1,1	
838,2 33	925	88,9 3.5	66,675 2.625	6,4 0.25	6,4 0.25	177	894	870	975	1010	1001	10	26,5	6	6	0,44	1,35	0,8	

7.3 Single row tapered roller bearings with a flanged outer ring d 35 – 65 mm

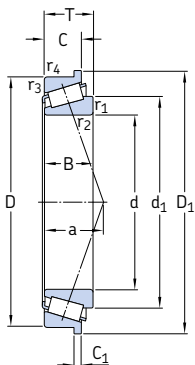

Principal dimensions			Basic load ratings		Fatigue load limit P_u	Speed ratings		Mass	Designation
d	D	T	dynamic	static		Reference speed	Limiting speed		
mm			kN		kN	r/min		kg	–
35	80	22,75	72,1	73,5	8,3	6 700	9 000	0,53	30307 RJ2/Q
40	68	19	52,8	71	7,65	7 000	9 500	0,29	32008 XR/QVA621
	80	19,75	61,6	68	7,65	6 300	8 500	0,44	30208 RJ2/Q
45	100	38,25	134	176	20	4 800	6 700	1,55	32309 BRJ2/QCL7C
55	120	45,5	190	260	30	3 800	5 600	2,55	* 32311 BRJ2/QCL7C
	140	36	194	228	27,5	3 600	4 800	2,4	33113 R/Q 30313 RJ2

* SKF Explorer bearing

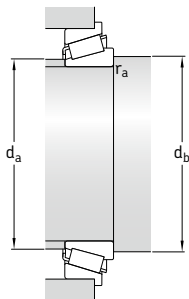

7.3

Dimensions										Abutment and fillet dimensions			Calculation factors		
d	d_1	D_1	B	C	C_1	$r_{1,2}$ min.	$r_{3,4}$ min.	a	d_a max.	d_b min.	r_a max.	e	Y	Y_0	
mm										mm			-		
35	54,5	85	21	18	4,5	2	1,5	16	46	44	1,5	0,31	1,9	1,1	
40	54,7	72	19	14,5	3,5	1	1	15	46	46	1	0,37	1,6	0,9	
	57,5	85	18	16	4	1,5	1,5	16	49	47	1	0,37	1,6	0,9	
45	74,8	106	36	30	7	2	1,5	30	55	53	1,5	0,54	1,1	0,6	
55	90,5	127	43	35	8	2,5	2	36	67	65	2	0,54	1,1	0,6	
65	88,3	116	34	26,5	5,5	1,5	1,5	26	74	72	1	0,4	1,5	0,8	
	98,7	147	33	28	6	3	2,5	28	84	77	2	0,35	1,7	0,9	

7.4 Matched bearings arranged face-to-face

d 25 – 85 mm

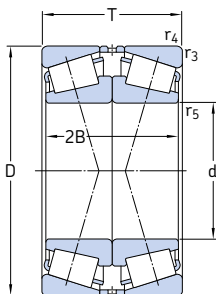

Principal dimensions			Basic load ratings		Fatigue load limit	Speed ratings		Mass	Designation
d	D	T	dynamic	static		Reference speed	Limiting speed		
mm	mm	mm	kN	kN	kN	r/min	r/min	kg	–
25	62	36,5	64,4	80	8,65	6 000	11 000	0,55	31305 J2/QDF
30	72	41,5	80,9	100	11,4	5 300	9 500	0,85	31306 J2/QDF
35	80	45,5	105	134	15,6	4 500	8 500	1,1	31307 J2/QDF
40	90	50,5	146	163	19	4 500	7 500	1,5	* 31308 J2/QCL7CDF
45	100	54,5	180	204	24,5	4 000	6 700	2	* 31309 J2/QCL7CDF
50	90	43,5	130	183	20,8	4 500	7 500	1,1	30210 J2/QDF
	110	58,5	208	240	28,5	3 600	6 000	2,6	* 31310 J2/QCL7CDF
55	90	54	180	270	30,5	4 500	7 000	1,35	* 33011/QDF03C170
	120	63	209	275	33,5	3 000	5 600	3,3	31311 J2/QDF
60	95	46	163	245	27	4 300	6 700	1,9	* 32012 X/QCL7CDFC250
	130	67	246	335	40,5	2 800	5 300	4,1	31312 J2/QDF
65	120	49,5	228	270	32,5	3 600	5 600	1,2	* 30213 J2/QDF
	140	72	281	380	47,5	2 600	4 800	5,05	31313 J2/QCL7CDF
70	110	50	172	305	34,5	3 400	5 600	1,8	32014 X/QDF
	110	62	220	400	45,5	3 400	5 600	2,4	33014/DF
	150	76	319	440	54	2 400	4 500	6,15	31314 J2/QCL7CDF
75	115	62	233	455	52	3 200	5 300	2,4	33015/QDF
	125	74	303	530	63	3 000	5 000	3,8	33115/QDFC150
	130	54,5	238	355	41,5	3 000	5 000	2,85	30215 J2/QDF
	130	66,5	275	425	49	3 000	5 000	3,4	32215 J2/QDF
	160	80	358	490	58,5	2 200	4 300	7,25	31315 J2/QCL7CDF
80	125	58	233	430	49	3 000	5 000	2,65	32016 X/QDFC165
	140	70,5	319	490	57	2 800	4 500	4,25	32216 J2/QDF
	170	85	380	530	64	2 200	4 000	8,75	31316 J1/QCL7CDF
85	130	58	238	450	51	2 800	4 800	2,8	32017 X/QDF
	130	72	308	620	69,5	2 800	4 800	3,55	33017/QDFC240

* SKF Explorer bearing

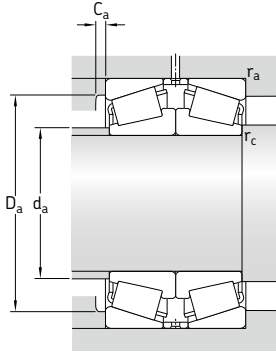

Dimensions				Abutment and fillet dimensions						Calculation factors			
d	2B	r _{3,4} min.	r ₅ min.	d _a max.	D _a min.	D _a max.	C _a min.	r _a max.	r _c max.	e	Y ₁	Y ₂	Y ₀
mm													
25	34	1,5	0,6	34	47	55	3	1,5	0,6	0,83	0,81	1,2	0,8
30	38	1,5	0,6	40	55	65	3	1,5	0,6	0,83	0,81	1,2	0,8
35	42	1,5	0,6	45	62	71	3	1,5	0,6	0,83	0,81	1,2	0,8
40	46	1,5	0,6	53	71	81	3	1,5	0,6	0,83	0,81	1,2	0,8
45	50	1,5	0,6	57	79	91	4	1,5	0,6	0,83	0,81	1,2	0,8
50	40	1,5	0,6	58	79	83	3	1,5	0,6	0,43	1,6	2,3	1,6
	54	2	0,6	62	87	100	4	2	0,6	0,83	0,81	1,2	0,8
55	54	1,5	0,6	63	81	83	5	1,5	0,6	0,31	2,2	3,3	2,2
	58	2	0,6	68	94	112	4	2	0,6	0,83	0,81	1,2	0,8
60	46	1,5	0,6	67	85	88	4	1,5	0,6	0,43	1,6	2,3	1,6
	62	2,5	1	74	103	118	5	2	1	0,83	0,81	1,2	0,8
65	46	1,5	0,6	78	106	113	4	1,5	0,6	0,4	1,7	2,5	1,6
	66	2,5	1	80	111	128	5	2	1	0,83	0,81	1,2	0,8
70	50	1,5	0,6	78	98	103	5	1,5	0,6	0,43	1,6	2,3	1,6
	62	1,5	0,6	78	99	103	5	1,5	0,6	0,28	2,4	3,6	2,5
	70	2,5	1	85	118	138	5	2	1	0,83	0,81	1,2	0,8
75	62	1,5	0,6	84	104	108	6	1,5	0,6	0,3	2,3	3,4	2,2
	74	1,5	0,6	84	109	117	6	1,5	0,6	0,4	1,7	2,5	1,6
	50	1,5	0,6	86	115	122	4	1,5	0,6	0,43	1,6	2,3	1,6
	62	1,5	0,6	85	114	122	4	1,5	0,6	0,43	1,6	2,3	1,6
	74	2,5	1	91	127	148	6	2	1	0,83	0,81	1,2	0,8
80	58	1,5	0,6	90	112	117	6	1,5	0,6	0,43	1,6	2,3	1,6
	66	2	0,6	91	122	130	5	2	0,6	0,43	1,6	2,3	1,6
	78	2,5	1	97	134	158	6	2	1	0,83	0,81	1,2	0,8
85	58	1,5	0,6	94	117	122	6	1,5	0,6	0,44	1,5	2,3	1,6
	72	1,5	0,6	94	118	122	6	1,5	0,6	0,3	2,3	3,4	2,2

7.4 Matched bearings arranged face-to-face

d 85 – 130 mm

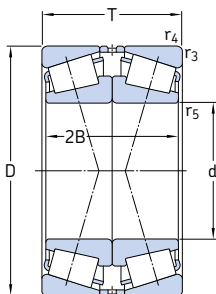

Principal dimensions			Basic load ratings		Fatigue load limit	Speed ratings		Mass	Designation
d	D	T	C	C ₀	P _u	Reference speed	Limiting speed	kg	–
mm			kN		kN	r/min		kg	–
85 cont.	150	61	303	440	51	2 600	4 300	4,3	30217 J2/QDF
	150	77	369	570	65,5	2 600	4 300	5,45	32217 J2/QDF
	150	98	495	850	96,5	2 400	4 300	7,35	33217/QDF
	180	89	413	570	67	2 000	3 800	10	31317 J2/DF
90	140	64	292	540	62	2 600	4 300	3,65	32018 X/QDF
	140	78	369	710	78	2 600	4 500	4,5	33018/QDFC150
	160	64	292	540	62	2 600	4 300	3,65	32218 J2/QDF
	160	65	336	490	57	2 400	4 000	5,15	30218 J2/DF
	190	93	457	630	73,5	1 900	3 400	11,5	31318 J2/DF
95	145	78	380	735	81,5	2 600	4 300	5	33019/QDF
	170	91	484	780	86,5	2 200	3 800	8,45	32219 J2/DF
	200	99	501	710	78	1 800	3 400	13	31319 J2/DF
100	150	64	292	560	62	2 400	4 000	3,95	32020 X/QDF
	180	74	418	640	72	2 200	3 600	7,6	30220 J2/DF
	180	98	539	880	96,5	2 200	3 600	10	32220 J2/DF
	215	103	693	980	106	1 900	3 200	16,5	30320 J2/DFC400
	215	113	644	930	102	1 700	3 000	18	31320 XJ2/DF
105	160	70	347	670	73,5	2 200	3 800	5	32021 X/QDF
110	170	76	402	780	85	2 200	3 600	6,3	32022 X/QDF
	180	112	627	1 250	134	2 000	3 400	11,5	33122/DF
	200	82	523	800	90	2 000	3 200	10,5	30222 J2/DF
	200	112	682	1 140	122	1 900	3 200	14,5	32222 J2/DF
	240	126	781	1 160	125	1 500	2 800	26	31322 XJ2/DF
120	180	76	418	830	88	2 000	3 400	6,75	32024 X/DF
	180	96	495	1 080	112	2 000	3 400	8,65	33024/DFC250
	215	87	583	915	98	1 800	3 000	13	30224 J2/DF
	215	123	792	1 400	146	1 800	3 000	18,5	32224 J2/DF
	260	119	968	1 400	146	1 600	2 600	29,5	30324 J2/DFC600
	260	136	935	1 400	146	1 400	2 400	38,5	31324 XJ2/DF
130	180	64	341	735	76,5	2 000	3 600	4,95	32926/DF
	200	90	539	1 080	110	1 800	3 000	10	32026 X/DF
	230	87,5	627	980	106	1 700	2 800	14,5	30226 J2/DF
	230	135,5	952	1 660	170	1 600	2 800	23	32226 J2/DF
	280	144	1 050	1 560	163	1 300	2 400	40	31326 XJ2/DF

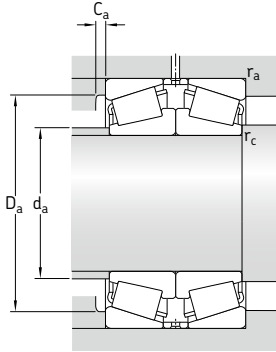

Dimensions				Abutment and fillet dimensions						Calculation factors			
d	2B	r _{3,4} min.	r ₅ min.	d _a max.	D _a min.	D _a max.	C _a min.	r _a max.	r _c max.	e	Y ₁	Y ₂	Y ₀
mm													
85 cont.	56	2	0,6	97	132	140	5	2	0,6	0,43	1,6	2,3	1,6
	72	2	0,6	97	130	140	5	2	0,6	0,43	1,6	2,3	1,6
	98	2	0,6	96	128	140	7	2	0,6	0,43	1,6	2,3	1,6
	82	3	1	103	143	166	6	2,5	1	0,83	0,81	1,2	0,8
90	64	1,5	0,6	100	125	132	6	1,5	0,6	0,43	1,6	2,3	1,6
	78	1,5	0,6	100	127	132	6	1,5	0,6	0,27	2,5	3,7	2,5
	64	2	0,6	100	125	132	6	1,5	0,6	0,43	1,6	2,3	1,6
	60	2	0,6	104	140	150	5	2	0,6	0,43	1,6	2,3	1,6
	86	3	1	109	151	176	5	2,5	1	0,83	0,81	1,2	0,8
95	78	1,5	0,6	104	131	138	7	1,5	0,6	0,28	2,4	3,6	2,5
	86	2,5	1	109	145	158	5	2,5	1	0,43	1,6	2,3	1,6
	90	3	1	114	157	186	5	2,5	1	0,83	0,81	1,2	0,8
100	64	1,5	0,6	110	134	142	6	1,5	0,6	0,46	1,5	2,2	1,4
	68	2,5	1	116	157	168	5	2	1	0,43	1,6	2,3	1,6
	92	2,5	1	115	154	168	5	2	1	0,43	1,6	2,3	1,6
	94	3	1	127	184	201	6	2,5	1	0,35	1,9	2,9	1,8
	102	3	1	121	168	201	7	2,5	1	0,83	0,81	1,2	0,8
105	70	2	0,6	116	143	150	6	2	0,6	0,44	1,5	2,3	1,6
110	76	2	0,6	123	152	160	7	2	0,6	0,43	1,6	2,3	1,6
	112	2	0,6	121	155	170	9	2	0,6	0,43	1,6	2,3	1,6
	76	2,5	1	129	174	188	6	2	1	0,43	1,6	2,3	1,6
	106	2,5	1	127	170	188	6	2	1	0,43	1,6	2,3	1,6
	114	3	1	135	188	226	7	2,5	1	0,83	0,81	1,2	0,8
120	76	2	0,6	132	161	170	7	2	0,6	0,46	1,5	2,2	1,4
	96	2	0,6	132	160	170	6	2	0,6	0,3	2,3	3,4	2,2
	80	2,5	1	141	187	203	6	2	1	0,43	1,6	2,3	1,6
	116	2,5	1	137	181	203	7	2	1	0,43	1,6	2,3	1,6
	116	3	1	153	221	245	7	2,5	1	0,35	1,9	2,9	1,8
	124	3	1	145	203	245	9	2,5	1	0,83	0,81	1,2	0,8
130	64	1,5	0,6	141	167	172	6	1,5	0,6	0,33	2	3	2
	90	2	0,6	144	178	190	7	2	0,6	0,43	1,6	2,3	1,6
	80	3	1	152	203	216	7	3	1	0,43	1,6	2,3	1,6
	128	3	1	146	193	216	7	2,5	1	0,43	1,6	2,3	1,6
	132	4	1,5	157	218	263	8	3	1,5	0,83	0,81	1,2	0,8

7.4 Matched bearings arranged face-to-face d 140 – 320 mm

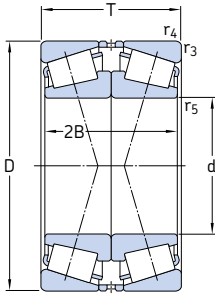

Principal dimensions			Basic load ratings		Fatigue load limit P_u	Speed ratings		Mass kg	Designation
d	D	T	dynamic C	static C_0		Reference speed	Limiting speed		
mm			kN		kN	r/min		kg	–
140	210	90	561	1 160	116	1 700	2 800	11	32028 X/DF
	250	91,5	721	1 140	116	1 500	2 600	18	30228 J2/DFC100
	250	143,5	1 100	2 000	200	1 500	2 600	29,5	32228 J2/DF
	300	154	1 190	1 800	176	1 200	2 200	52,5	31328 XJ2/DF
150	225	96	644	1 320	132	1 600	2 600	13,5	32030 X/DF
	270	98	737	1 120	114	1 400	2 400	22,5	30230/DFC350
	270	154	1 250	2 280	224	1 400	2 400	37	32230 J2/DF
	320	164	1 340	2 040	200	1 100	2 000	58,5	31330 XJ2/DF
160	240	102	737	1 560	156	1 500	2 400	16	32032 X/DF
	290	104	913	1 460	143	1 300	2 200	27,5	30232 J2/DF
	290	168	1 510	2 800	265	1 300	2 200	48	32232 J2/DF
170	230	76	484	1 160	110	1 500	2 800	9,2	32934/DFC225
	260	114	880	1 830	180	1 400	2 200	22	32034 X/DF
	310	182	1 720	3 250	300	1 200	2 000	59	32234 J2/DF
180	250	90	605	1 460	137	1 400	2 600	14	32936/DF
	280	128	1 100	2 320	220	1 300	2 000	29,5	32036 X/DF
	320	182	1 720	3 250	300	1 100	1 900	61	32236 J2/DF
190	260	90	616	1 530	143	1 300	2 400	14,5	32938/DF
	290	128	1 120	2 400	224	1 200	2 000	30,5	32038 X/DF
	340	120	1 230	2 000	190	1 100	1 800	50	30238 J2/DFC700
200	310	140	1 280	2 750	255	1 100	1 900	39	32040 X/DF
	360	128	1 340	2 240	212	1 000	1 700	52	30240 J2/DFC570
	360	208	2 090	4 000	360	1 000	1 700	88	32240 J2/DF
220	300	102	842	2 000	183	1 100	2 000	21	32944/DFC300
	340	152	1 540	3 350	300	1 000	1 700	51	32044 X/DF
240	360	152	1 570	3 550	315	950	1 600	54,5	32048 X/DF
260	400	174	1 980	4 400	380	850	1 400	79,5	32052 X/DF
280	420	174	2 050	4 750	400	800	1 300	84,5	32056 X/DF
300	420	152	1 790	4 500	375	800	1 400	65,5	32960/DF
320	480	200	2 640	6 200	510	850	1 300	125	32064 X/DF

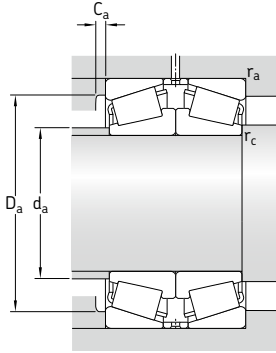

Dimensions				Abutment and fillet dimensions						Calculation factors			
d	2B	r _{3,4} min.	r ₅ min.	d _a max.	D _a min.	D _a max.	C _a min.	r _a max.	r _c max.	e	Y ₁	Y ₂	Y ₀
mm				mm									
140	90	2	0,6	153	187	200	7	2	0,6	0,46	1,5	2,2	1,4
	84	3	1	164	219	236	7	2,5	1	0,43	1,6	2,3	1,6
	136	3	1	159	210	236	8	2,5	1	0,43	1,6	2,3	1,6
	140	4	1,5	169	235	283	9	3	1,5	0,83	0,81	1,2	0,8
150	96	2,5	1	164	200	213	8	2	1	0,46	1,5	2,2	1,4
	90	3	1	175	234	256	9	2,5	1	0,43	1,6	2,3	1,6
	146	3	1	171	226	256	8	2,5	1	0,43	1,6	2,3	1,6
	150	4	1,5	181	251	303	9	3	1,5	0,83	0,81	1,2	0,8
160	102	2,5	1	175	213	228	8	2	1	0,46	1,5	2,2	1,4
	96	3	1	189	252	275	8	2,5	1	0,43	1,6	2,3	1,6
	160	3	1	183	242	275	10	2,5	1	0,43	1,6	2,3	1,6
170	76	2	0,6	183	213	220	7	2	0,6	0,37	1,8	2,7	1,8
	114	2,5	1	188	230	246	10	2	1	0,44	1,5	2,3	1,4
	172	4	1,5	196	259	293	10	3	1,5	0,43	1,6	2,3	1,6
180	90	2	0,6	194	225	240	8	2	0,6	0,48	1,4	2,1	1,4
	128	2,5	1	199	247	266	10	2	1	0,43	1,6	2,3	1,6
	172	4	1,5	204	267	303	9	3	1,5	0,44	1,5	2,3	1,6
190	90	2	0,6	204	235	248	8	2	0,6	0,48	1,4	2,1	1,4
	128	2,5	1	210	257	276	10	2	1	0,44	1,5	2,3	1,6
	110	4	1,5	224	298	323	9	3	1,5	0,43	1,6	2,3	1,6
200	140	2,5	1	222	273	296	11	2	1	0,43	1,6	2,3	1,6
	116	4	1,5	237	315	343	9	3	1,5	0,43	1,6	2,3	1,6
	196	4	1	231	302	343	11	3	1	0,4	1,7	2,5	1,6
220	102	2,5	1	234	275	286	9	2	1	0,43	1,6	2,3	1,6
	152	3	1	244	300	325	12	2,5	1	0,43	1,6	2,3	1,6
240	152	3	1	262	318	346	12	2,5	1	0,46	1,5	2,2	1,4
260	174	4	1,5	287	352	382	13	3	1,5	0,43	1,6	2,3	1,6
280	174	4	1,5	305	370	402	14	3	1,5	0,46	1,5	2,2	1,4
300	152	3	1	324	383	406	12	2,5	1	0,4	1,7	2,5	1,6
320	200	4	1,5	350	424	462	15	3	1,5	0,46	1,5	2,2	1,4

7.5 Matched bearings arranged back-to-back d 40 – 180 mm

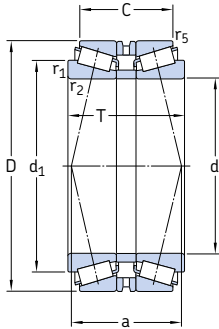

Principal dimensions			Basic load ratings		Fatigue load limit	Speed ratings		Mass	Designation
d	D	T	dynamic	static		Reference speed	Limiting speed		
mm			kN	kN	P_u	r/min		kg	–
40	90	72	147	190	21,6	4 800	8 000	1,9	30308T72 J2/QDBC220
75	130	70	238	355	41,5	3 000	5 000	3,25	30215T70 J2/DBC270
	130	80	275	425	49	3 000	5 000	6,8	32215T80 J2/QDB
80	140	78	319	490	57	2 800	4 500	4,45	32216T78 J2/QDBC110
85	130	66	238	450	51	2 800	4 800	2,7	32017T66 X/QDBC280
	150	71	303	440	51	2 600	4 300	4,1	30217T71 J2/QDB
90	190	103	457	630	73,5	1 900	3 400	12,5	31318T103 J2/DB31
100	180	108	539	880	96,5	2 200	3 600	10,5	32220T108 J2/DB
	180	140	539	880	96,5	2 200	3 600	12,5	32220T140 J2/DB11
110	170	84	402	780	85	2 200	3 600	6,5	32022T84 X/QDBC200
120	180	84	418	830	88	2 000	3 400	7	32024T84 X/QDBC200
	215	146	792	1 400	146	1 800	3 000	21	32224T146 J2/DB31C210
130	230	97,5	627	980	106	1 700	2 800	15	30226T97.5 J2/DB
	280	142	1 080	1 600	166	1 400	2 400	36,5	30326T142 J2/DB11C150
140	210	130	561	1 160	116	1 700	2 800	12,5	32028T130 X/QDB
	250	106	721	1 140	116	1 500	2 600	19,5	30228T106 J2/DB
	250	158	1 100	2 000	200	1 500	2 600	31	32228T158 J2/DB
150	270	168	1 250	2 280	224	1 400	2 400	38	32230T168 J2/DB
	270	248	1 250	2 280	224	1 400	2 400	39,5	32230T248 J2/DB31
	320	179	1 340	2 040	200	1 100	2 000	58,5	31330T179 XJ2/DB
160	290	179	1 510	2 800	265	1 300	2 200	52,5	32232T179 J2/DB32C230
170	260	162	880	1 830	180	1 400	2 200	30,5	32034T162 X/DB31
180	250	135	605	1 460	137	1 400	2 600	14,5	32936T135/DBC260
	280	150	1 100	2 320	220	1 300	2 200	29,5	32036T150 X/DB
	320	196	1 720	3 250	300	1 100	1 900	61,5	32236T196 J2/DB32

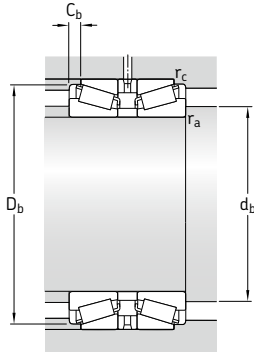

Dimensions						Abutment and fillet dimensions					Calculation factors			
d	d ₁	C	r _{1,2}	r ₅	a	d _b	D _b	C _b	r _a	r _c	e	Y ₁	Y ₂	Y ₀
mm	~		min.	min.		mm		min.	max.	max.	-			
40	62,5	61,5	2	0,6	50	49	82	5	2	0,6	0,35	1,9	2,9	1,8
75	99,6	59,5	2	0,6	69	84	124	5	1,5	0,6	0,43	1,6	2,3	1,6
	100	67,5	2	0,6	72	84	125	6	2	0,6	0,43	1,6	2,3	1,6
80	106	63,5	2,5	0,6	68	90	134	7	2	0,6	0,43	1,6	2,3	1,6
85	108	52	1,5	0,6	64	92	125	7	1,5	0,6	0,44	1,5	2,3	1,4
	112	58,5	2,5	0,6	71	95	141	6,5	2	0,6	0,43	1,6	2,3	1,6
90	138	70	4	1	124	105	179	16,5	3	1	0,83	0,81	1,2	0,8
100	136	88	3	1	92	112	171	10	2,5	1	0,43	1,6	2,3	1,6
	136	120	3	1	124	112	171	10	2,5	1	0,43	1,6	2,3	1,6
110	140	66	2,5	0,6	80	121	163	9	2	0,6	0,43	1,6	2,3	1,6
120	150	66	2,5	0,6	86	131	173	9	2	0,6	0,46	1,5	2,2	1,4
	164	123	3	1	125	132	204	11,5	2,5	1	0,43	1,6	2,3	1,6
130	173	78	4	1	99	146	217	9,5	3	1	0,43	1,6	2,3	1,6
	192	112,5	5	1,5	116	150	255	14,5	4	1,5	0,35	1,9	2,9	1,8
140	175	108	2,5	0,6	132	152	202	11	2	0,6	0,46	1,5	2,2	1,4
	187	86,5	4	1	108	156	234	9,5	3	1	0,43	1,6	2,3	1,6
	191	130,5	4	1	134	156	238	13,5	3	1	0,43	1,6	2,3	1,6
150	205	134	4	1	142	166	254	17	3	1	0,43	1,6	2,3	1,6
	205	214	4	1	222	166	254	17	3	1	0,43	1,6	2,3	1,6
	234	115	5	1,5	207	170	300	32	4	1,5	0,83	0,81	1,2	0,9
160	222	145	4	1	150	176	274	17	3	1	0,43	1,6	2,3	1,6
170	214	134	3	1	160	182	249	14	2,5	1	0,44	1,5	2,3	1,4
180	216	83	2,5	0,6	122	192	241	11	2	0,6	0,48	1,4	2,1	1,4
	230	118	3	1	140	194	267	16	2,5	1	0,43	1,6	2,3	1,6
	247	156	5	1,5	169	200	297	14	4	1,5	0,44	1,5	2,3	1,4

7.5 Matched bearings arranged back-to-back d 190 – 260 mm

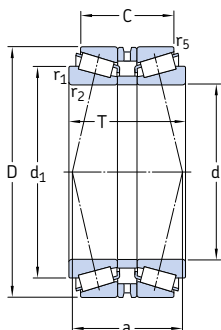

Principal dimensions			Basic load ratings		Fatigue load limit	Speed ratings		Mass	Designation
d	D	T	dynamic	static		Reference speed	Limiting speed		
mm	mm	mm	kN	kN	kN	r/min	r/min	kg	–
190	260	102	616	1 530	143	1 300	2 400	15	32938T102/DB31
	260	122	616	1 530	143	1 300	2 400	15,5	32938T122/DBCG
	290	146	1 120	2 400	224	1 200	2 000	31,5	32038T146 X/DB42C220
	290	146	1 120	2 400	224	1 200	2 000	31,5	32038T146 X/DBC220
	290	183	1 120	2 400	224	1 200	2 000	32,5	32038T183 X/DB31C330
200	310	154,5	1 280	2 750	255	1 100	1 900	39,5	32040T154.5 X/DB11C170
220	340	165	1 540	3 350	300	1 000	1 700	52	32044T165 X/DB11C170
	340	165	1 540	3 350	300	1 000	1 700	52	32044T165 X/DB42C220
	340	165	1 540	3 350	300	1 000	1 700	52	32044T165 X/DBC340
	340	168	1 540	3 350	300	1 000	1 700	52	32044T168 X/DB
240	360	172	1 570	3 550	315	950	1 600	56	32048T172 X/DB
260	400	189	1 980	4 400	380	850	1 400	80,5	32052T189 X/DBC280
	400	194	1 980	4 400	380	850	1 400	80,5	32052T194 X/DB

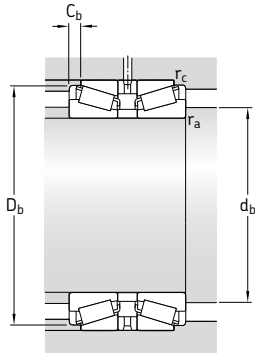

Dimensions						Abutment and fillet dimensions					Calculation factors			
d	d ₁ ~	C	r _{1,2} min.	r ₅ min.	a	d _b min.	D _b min.	C _b min.	r _a max.	r _c max.	e	Y ₁	Y ₂	Y ₀
mm						mm					-			
190	227	80	2,5	0,6	122	202	251	11	2	0,6	0,48	1,4	2,1	1,4
	227	100	2,5	0,6	142	202	251	11	2	0,6	0,48	1,4	2,1	1,4
	240	114	3	1	142	204	279	16	2,5	1	0,44	1,5	2,3	1,4
	240	114	3	1	142	204	279	16	2,5	1	0,44	1,5	2,3	1,4
	240	151	3	1	179	204	279	16	2,5	1	0,44	1,5	2,3	1,4
200	254	120,5	3	1	147	214	297	17	2,5	1	0,43	1,6	2,3	1,6
220	280	127	4	1	157	236	326	19	3	1	0,43	1,6	2,3	1,6
	280	127	4	1	157	236	326	19	3	1	0,43	1,6	2,3	1,6
	280	127	4	1	157	236	326	19	3	1	0,43	1,6	2,3	1,6
	280	130	4	1	160	236	326	19	3	1	0,43	1,6	2,3	1,6
240	300	134	3	1	175	256	346	19	3	1	0,46	1,5	2,2	1,4
260	328	145	5	1,5	183	282	383	22	4	1,5	0,43	1,6	2,3	1,6
	328	150	5	1,5	188	282	383	22	4	1,5	0,43	1,6	2,3	1,6

7.6 Matched bearings arranged in tandem d 55 – 80 mm

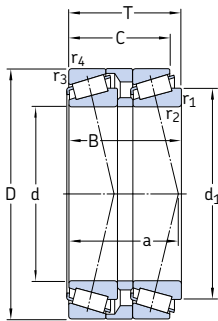

Principal dimensions			Basic load ratings		Fatigue load limit	Speed ratings		Mass	Designation
d	D	T	dynamic	static		Reference speed	Limiting speed		
mm	mm	mm	kN	kN	kN	r/min	r/min	kg	-
55	115	73	216	325	39	4 000	5 600	3,5	T7FC 055T73/QCL7CDTC10
60	125	37	305	405	49	3 600	5 300	4,05	T7FC 060T80/QCL7CDTC10
70	140	39	355	480	55	3 200	4 500	11	T7FC 070T83/QCL7CDTC10
80	160	98	391	630	71	2 800	4 000	16,5	T7FC 080T98/QCL7CDTC20

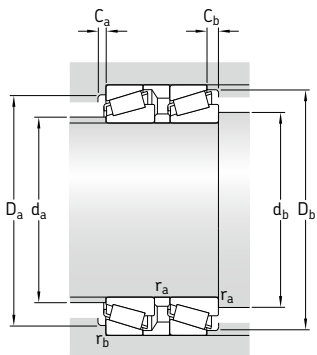
Dimensions
Abutment and fillet dimensions
Calculation factors

d	d ₁	B	C	r _{1,2} min.	r _{3,4} min.	a	d _a max.	d _b min.	D _a min.	D _a max.	D _b min.	C _a min.	C _b min.	r _a max.	r _b max.	e	Y	Y ₀
mm							mm									-		
55	89,5	70	62,5	3	3	78	66	67	86	103	109	4	10,5	2,5	2,5	0,88	0,68	0,4
60	97,2	76,5	69	3	3	84	72	72	94	111	119	4	11	2,5	2,5	0,83	0,72	0,4
70	110	79,5	71	3	3	47	82	82	106	126	133	5	12	2,5	2,5	0,88	0,68	0,4
80	125	94	84	3	3	106	94	92	121	146	152	5	14	2,5	2,5	0,88	0,68	0,4

7.6



8 Spherical roller bearings

Designs and variants	880
Factors that influence SKF spherical roller bearing performance	881
Assortment	882
Basic design bearings	882
Cages	883
Sealing solutions	884
Greases for sealed bearings	885
Relubrication of sealed bearings	885
Bearings for vibratory applications	887
System solutions for vibrating screens	888
Performance classes	889
SKF Explorer bearings	889
SKF Energy Efficient (E2) bearings	889
Bearing data	890
(Dimension standards, tolerances, internal clearance, misalignment, friction, starting torque, power loss, defect frequencies)	
Loads	894
(Minimum load, axial load carrying capacity, equivalent loads)	
Temperature limits	896
Permissible speed	896
Design of bearing arrangements	897
Free space on both sides of the bearing	897
Abutments for sealed bearings	898
Bearings on sleeves	898
Appropriate bearing housings	899
Mounting	900
Mounting bearings with a tapered bore	900
Designation system	902

Product tables

8.1 Spherical roller bearings	904
8.2 Sealed spherical roller bearings	928
8.3 Spherical roller bearings for vibratory applications	936
8.4 Spherical roller bearings on an adapter sleeve	940
8.5 Spherical roller bearings on a withdrawal sleeve	946
8.6 Sealed spherical roller bearings on an adapter sleeve	954

Other spherical roller bearings

Bearings with Solid Oil	1185
SKF DryLube bearings	1191
NoWear coated bearings	1241
Application specific bearings	→ contact SKF
SKF ConCentra roller bearing units	→ skf.com/bearings



Designs and variants

Spherical roller bearings have two rows of rollers, a common sphered outer ring raceway and two inner ring raceways inclined at an angle to the bearing axis (→ **fig. 1**). The centre point of the sphere in the outer ring raceway is at the bearing axis. Therefore, the bearings are self-aligning (→ **fig. 2**) and insensitive to misalignment of the shaft relative to the housing, which can be caused, for example, by shaft deflection. Spherical roller bearings are designed to accommodate heavy radial loads, as well as heavy axial loads in both directions.

More information

Bearing life and load ratings	63
Design considerations	159
Bearing systems	160
Recommended fits	169
Abutment and fillet dimensions	208
Lubrication	239
Mounting, dismounting and bearing care	271
Mounting instructions for individual bearings	→ skf.com/mount
<i>SKF bearing maintenance handbook</i>	(ISBN 978-91-978966-4-1)
SKF Drive-up Method	→ skf.com/drive-up

Fig. 1

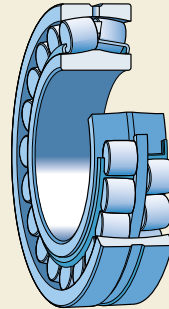

Fig. 2

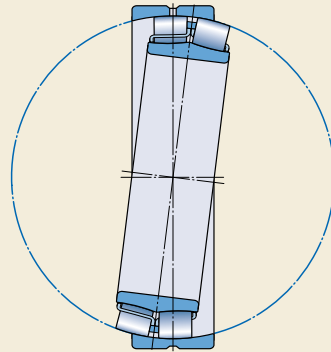

Fig. 3

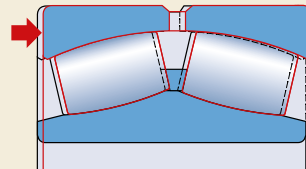
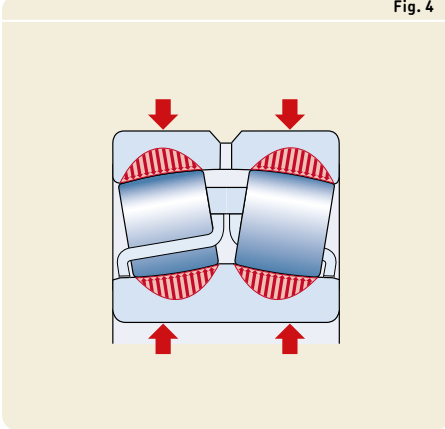

Fig. 4



Factors that influence SKF spherical roller bearing performance

Bearing performance is not only determined by load or speed ratings. There are a number of other factors that contribute to bearing performance. To a large extent, performance is influenced by the geometry of the rollers, raceways and cages, the heat treatment, as well as the surface finish of all contact surfaces. Main factors which influence SKF spherical roller bearing performance include, but are not limited to:

- **Symmetrical rollers**
Symmetrical rollers self-adjust (→ fig. 3), providing optimal load distribution along the roller length. This keeps stresses low under all load conditions and extends bearing service life.
- **Roller tolerances**
The rollers in an SKF spherical roller bearing are manufactured to extremely tight tolerances for dimension and form. Each roller is virtually identical in size and shape to the other rollers in the set. This optimizes load distribution over the rollers to maximize bearing service life.
- **Special roller profile**
The roller profile determines the stress distribution in the roller/raceway contact area. The special profile distributes loads more evenly along the rollers and prevents stress

Fig. 5

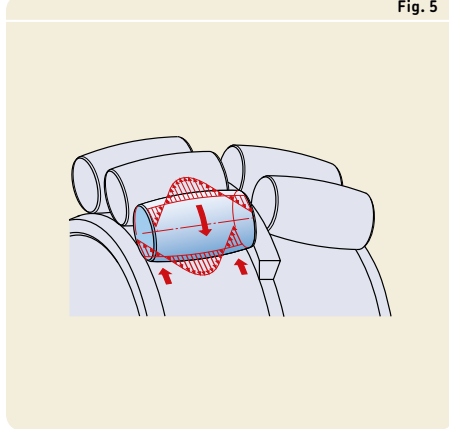

peaks at the roller ends to extend bearing service life (→ fig. 4).

- **Self-guiding rollers and a guide ring between the two rows of rollers**
Self-guiding rollers reduce friction and frictional heat (→ fig. 5). A guide ring guides unloaded rollers so that they enter the load zone in the optimal position.
- **Metal cages**
All SKF spherical roller bearings contain strong metal cages. This enables them to tolerate high temperatures and all lubricants.

8 Spherical roller bearings

Assortment

The assortment of SKF spherical roller bearings is the widest on the market and includes standard bearings and application specific bearings. Almost all SKF spherical roller bearings are available with either a cylindrical or tapered bore. Depending on the bearing series, the tapered bore has a taper of either 1:12 (designation suffix K) or 1:30 (designation suffix K30).

The assortment of standard bearings includes:

- basic design bearings
- sealed bearings
- bearings for vibratory applications
- SKF Energy Efficient (E2) bearings

Spherical roller bearings listed in this catalogue constitute the basic SKF assortment and are only part of the total assortment. For applications where the bearings are subjected to unique operating conditions, SKF can customize bearings to meet the needs of that particular application. For example, bearings for:

- printing presses, paper mills or coaters in high precision execution
- very arduous operating conditions, e. g. continuous casters
- high temperature applications
- mounting with loose fit on roll necks
- railway vehicles

For additional information about application specific spherical roller bearings, contact the SKF application engineering service.

Basic design bearings

Depending on their series and size, standard SKF spherical roller bearings are manufactured to one of following basic designs (→ fig. 6):

- CC design bearings have two stamped window-type steel cages, an inner ring without flanges and a guide ring centred on the inner ring. The CC design is indicated by the designation suffix C or CC. Large CC design bearings with the designation suffix EC or ECC have an optimized internal design for increased load carrying capacity.
- CA design bearings have a machined double prong-type brass cage, an inner ring with a retaining flange on both sides and a guide ring centred on the inner ring. The flanges on the inner ring are designed to keep the rollers in place when swivelling the bearing during installation or maintenance. The flanges are not designed to guide the rollers or accommodate any axial load. The CA design is indicated by the designation suffix CA. Large CA design bearings with the designation suffix ECA have an optimized internal design for increased load carrying capacity.

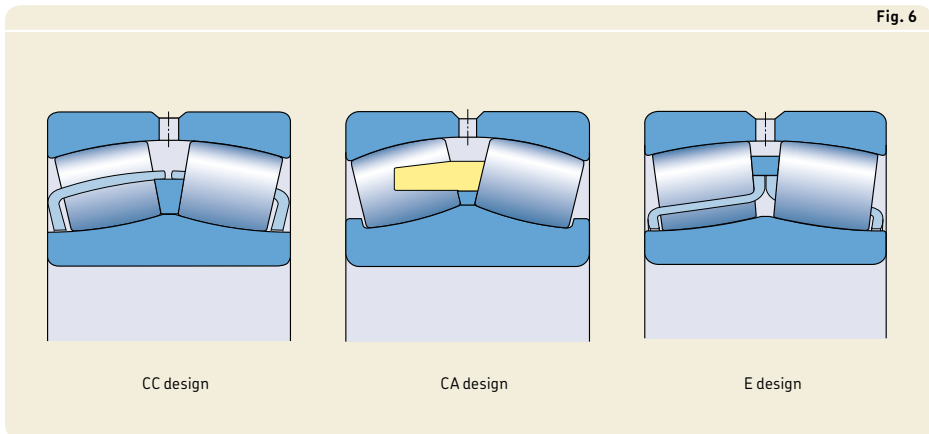

- E design bearings have two stamped window-type steel cages, an inner ring without flanges and a guide ring centred on the inner ring ($d \leq 65$ mm) or on the cages ($d > 65$ mm). They have an annular groove and three lubrication holes in the outer ring. E design bearings are indicated by the designation suffix E. All E design bearings have an optimized internal design for increased load carrying capacity.

Annular groove and lubrication holes

SKF spherical roller bearings are available with an annular groove and three lubrication holes in the outer ring (designation suffix W33) or three lubrication holes in the outer ring (designation suffix W20) (→ **fig. 7**). SKF E design bearings (→ **fig. 6**) and SKF Energy Efficient (E2) bearings have an annular groove and three lubrication holes as standard and therefore, the W33 designation suffix is not necessary.

Cages

Cages in SKF spherical roller bearings are an integral part of the bearing internal design. Depending on their internal design, series and size, SKF spherical roller bearings are fitted with one of the cages shown in **fig. 6**. For additional information about the suitability of cages, refer to *Cages* (→ **page 37**) and *Cage materials* (→ **page 152**).

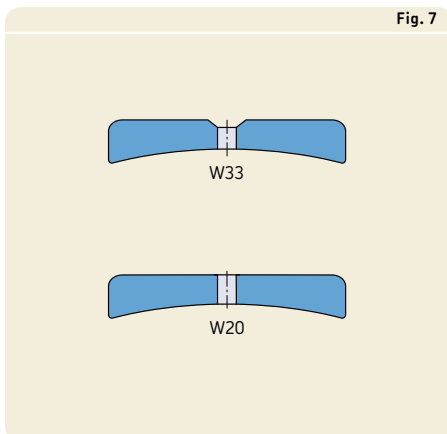

8 Spherical roller bearings

Sealing solutions

With the exception of bearings designated with a BS2- prefix, the boundary dimensions of sealed spherical roller bearings are in accordance with ISO 15. Bearings with a BS2- prefix, for example BS2-2214-2CS, are based on 222 E or 223 E series bearings, but are slightly wider to accommodate the seals.

Sealed spherical roller bearings have the same features and internal design as basic design spherical roller bearings and are available with a cylindrical bore as standard. Some sizes are also available with a tapered bore or can be supplied with a tapered bore on request.

Sealed spherical roller bearings have a contact seal reinforced with a sheet steel insert, fitted on both sides. They can also be supplied with a seal on only one side. The bearings can be fitted with seals made of one of the following materials:

- NBR (designation suffix CS)
- HNBR (designation suffix CS5)
- FKM (designation suffix CS2)

The seals are fitted in a recess on the outer ring and seal against the inner ring. On larger bearings, the seals are fixed by a retaining ring (→ fig. 8).

Sealed spherical roller bearings are supplied lubricated and should not be washed. For many application conditions, the bearings do not require relubrication and can be consid-

ered relubrication-free (→ *Relubrication of sealed bearings*).

SKF does not recommend heating sealed spherical roller bearings above 80 °C (175 °F) during the mounting process. However, if higher temperatures are necessary, make sure that the temperature does not exceed the permissible temperature of either the seal or grease, whichever is lowest.

WARNING

Seals made of FKM (fluoro rubber) exposed to an open flame or temperatures above 300 °C (570 °F) are a health and environmental hazard! They remain dangerous even after they have cooled.

Read and follow the safety precautions under *Seal materials* (→ page 155).

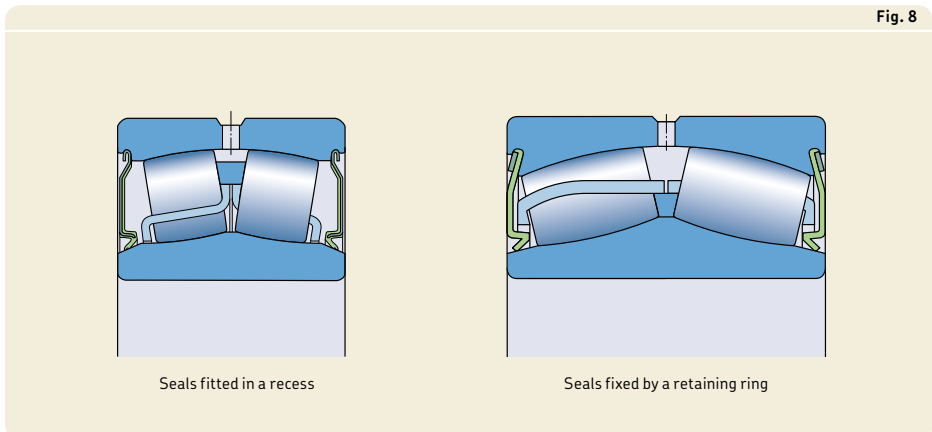

Fig. 8

Greases for sealed bearings

Sealed spherical roller bearings are filled as standard with SKF LGEP 2 grease. Bearings filled with SKF LGHB 2 grease can be supplied on request. Technical specification of both greases are listed in **table 1**.

For additional information about greases, refer to *Lubrication* (→ **page 239**).

Relubrication of sealed bearings

Sealed spherical roller bearings are designed to operate relubrication-free. For bearings lubricated with the standard grease LGEP 2 (designation suffix VT143), the relubrication-free operating conditions can be identified using **diagram 1**. The diagram is valid for bearings in light to normal load applications ($P \leq 0,1 C$) on a horizontal shaft and a load ratio $F_a/F_r \leq e$. For other operating conditions, the grease life can be estimated by multiplying

Diagram 1

Relubrication-free operating conditions for sealed spherical roller bearings with standard SKF LGEP 2 grease (designation suffix VT143)

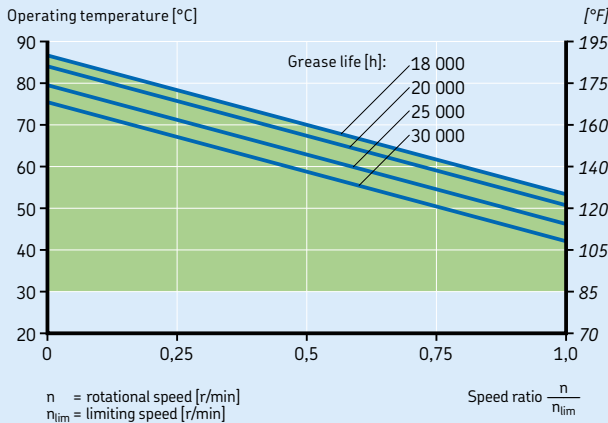

Table 1

Technical specifications of SKF greases for sealed spherical roller bearings

Grease	Designation suffix	Temperature range ¹⁾							Thickener	Base oil type	NLGI consistency class	Base oil viscosity [mm ² /s]	
		-50	0	50	100	150	200	250				at 40°C (105 °F)	at 100°C (210 °F)
LGEP 2	VT143								Lithium soap	Mineral	2	200	16
LGHB 2	GEM								Calcium complex sulphonate	Mineral	2	400	26,5

¹⁾ Refer to the SKF traffic light concept → **page 244**

8 Spherical roller bearings

the relubrication interval for open bearings (→ *Relubrication*, **page 252**) by a factor of 2,7.

In applications that have a life requirement outside the green area of **diagram 1** (→ **page 885**), the bearings may require relubrication.

A suitable grease quantity to relubricate sealed bearings can be obtained using

$$G_p = 0,0015 D B$$

where

G_p = grease quantity [g]

D = bearing outside diameter [mm]

B = bearing width [mm]

The grease should be applied slowly through the lubrication holes in the outer ring while the bearing is rotating, if possible, to avoid damaging the seals. SKF recommends relubricating with the same grease as the initial fill.

Bearings for vibratory applications

For vibratory applications, SKF supplies spherical roller bearings with a cylindrical or tapered bore and surface-hardened stamped steel cages (series designations 223../VA405). These bearings have the same dimensions and performance characteristics as basic design bearings, but have C4 radial internal clearance as standard.

Bearings for vibratory applications are also available with a PTFE coated cylindrical bore (designation suffix VA406). These bearings are manufactured to VA405 specifications, with the exception of the bore. VA406 bearings are intended for the non-locating bearing position in vibratory applications with outer ring rotation. The PTFE coating prevents fretting corrosion between the shaft and the bearing bore. Therefore, shafts do not require special heat treatments or coatings.

All bearings are equipped with an annular groove and three lubrication holes in the outer ring.

Depending on their size, SKF spherical roller bearings for vibratory applications are manufactured to one of following designs (→ **fig. 9**):

- E/VA405 spherical roller bearings have two surface-hardened stamped window-type steel cages, an inner ring without flanges and a guide ring centred on the inner ring or on the cages.
- EJA/VA405 and CCJA/W33VA405 spherical roller bearings have two surface-hardened stamped window-type steel cages, an inner ring without flanges and a guide ring centred on the outer ring raceway.

WARNING

PTFE coatings exposed to an open flame or temperatures above 300 °C (570 °F) are a health and environmental hazard! They remain dangerous even after they have cooled.

Read and follow the safety precautions under *Seal materials* (→ **page 155**).

Fig. 9

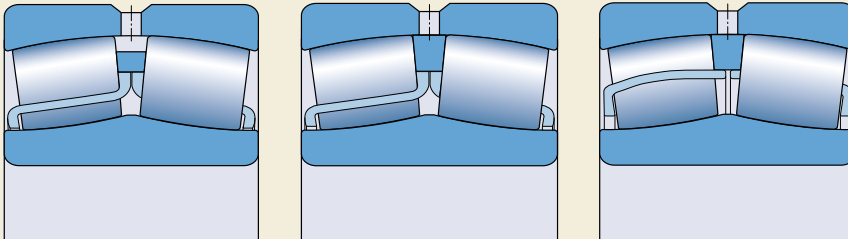

E/VA405 design

EJA/VA405 design

CCJA/W33VA405 design

8 Spherical roller bearings

Acceleration

Vibratory applications, such as vibrating screens or exciters, induce accelerations of rollers and cages in the bearings. This puts extra demands on the bearing design. SKF spherical roller bearings for vibratory applications can withstand considerably faster accelerations than corresponding standard bearings. The permissible acceleration depends on the lubricant and the mode of acceleration.

- Mode 1
The bearing is subjected to a rotating outer ring load in combination with a rotating acceleration field, or an internally induced angular acceleration field due to rapid speed variations. These accelerations cause the unloaded rollers to generate cyclic loads on the cages.
- Mode 2
The bearing is subjected to impact loads, which generate a linear acceleration in a constant radial direction, causing the unloaded rollers to “hammer” the cage pockets.

Typical examples for mode 1 are vibrating screens (→ **fig. 10**), planetary gears and general arrangements subjected to rapid starts or rapid speed variations. A typical example for mode 2 is the acceleration generated when rail wheels roll over rail joints (→ **fig. 11**). Road rollers, where the roller is vibrating against a

relatively hard surface, are subjected to a combination of mode 1 and 2 acceleration.

Values for the permissible acceleration are listed in the product tables and are valid for oil lubricated bearings. The values are expressed in multiples of g , where g is the acceleration of gravity ($g = 9,81 \text{ m/s}^2$).

System solutions for vibrating screens

In addition to single bearings for vibrating screens, SKF has developed fault detection and bearing systems that can improve performance, reduce maintenance and monitor machine condition in vibratory equipment. For additional information about the SKF Copperhead system solution for vibrating screens, contact the SKF application engineering service.

Fig. 10

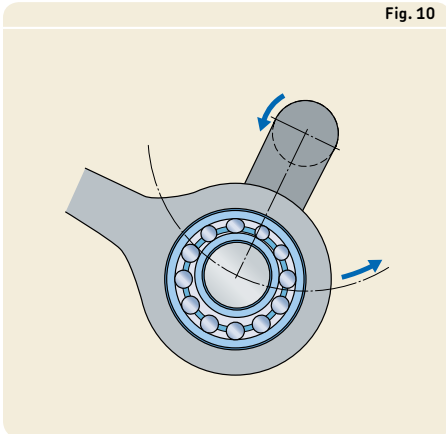
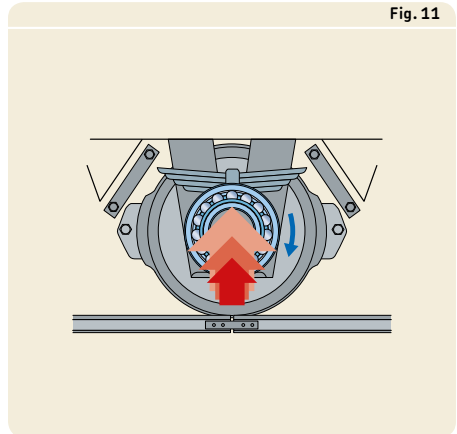

Fig. 11



Performance classes

SKF Explorer bearings

In response to the ever-demanding performance requirements of modern machinery, SKF developed the SKF Explorer performance class of rolling bearings.

SKF Explorer spherical roller bearings realized this substantial improvement in performance by optimizing the internal geometry and surface finish of all contact surfaces, combining the extremely clean and homogenous steel with a unique heat treatment, improving the cage, roller profile and the geometry of the raceways.

These improvements provide the following benefits:

- higher dynamic load carrying capacity compared to conventional design bearings
- improved wear-resistance
- reduced noise and vibration levels
- less frictional heat
- significantly extended bearing service life

SKF Explorer bearings reduce environmental impact by enabling downsizing and reducing both lubricant and energy use. Just as importantly, SKF Explorer bearings can reduce the need for maintenance and contribute to increased productivity.

SKF Explorer bearings are shown with an asterisk in the product tables. The bearings retain the designation of earlier standard bearings. However, each bearing and its box are marked with the name “SKF EXPLORER”.

SKF Energy Efficient (E2) bearings

To meet the ever-increasing demand to reduce friction and energy use, SKF has developed the SKF Energy Efficient (E2) performance class of rolling bearings. SKF E2 spherical roller bearings are characterized by a frictional moment in the bearing that is at least 30% lower when compared to a same-sized SKF Explorer bearing.

Reduced operating temperatures improve lubrication conditions and enable extended lubrication intervals or higher speeds.

The enhanced performance characteristics require the following conditions:

- speed $n > 500$ r/min
- operating temperature ≤ 110 °C (230 °F)
- load $P \leq 0,067$ C
- lubrication and relubrication with SKF LESA 2 grease only (→ **table 2**).

For loads $P > 0,067$ C, SKF Explorer bearings are more beneficial.

Table 2

Technical specifications of SKF LESA 2 grease for SKF E2 spherical roller bearings

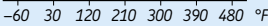
Grease	Temperature range ¹⁾							Thickener	Base oil type	NLGI consistency class	Base oil viscosity [mm ² /s]	
	-50	0	50	100	150	200	250 °C				at 40°C (105 °F)	at 100 °C (210 °F)
LESA 2								Lithium soap	Synthetic polyalphaolefine	2	18	4,5
												

¹⁾ Refer to the SKF traffic light concept → **page 244**

Bearing data

Dimension standards	Boundary dimensions: ISO 15, except for the width of sealed bearings with a BS2- prefix
Tolerances	Normal P5 running accuracy on request (designation suffix C08) SKF Explorer bearings ($d \leq 300$ mm): <ul style="list-style-type: none"> width tolerance at least 50% tighter than ISO standard (→ table 3) P5 running accuracy
For additional information (→ page 132)	Values: ISO 492 (→ tables 3 to 5, pages 137 to 139)
Internal clearance	Normal, C3 Check availability of C2, C4 or C5 clearance classes Bearings for vibratory applications: C4
For additional information (→ page 149)	Values: <ul style="list-style-type: none"> cylindrical bore (→ table 4, page 892) tapered bore (→ table 5, page 893) Values are in accordance with ISO 5753-1 (as far as standardized) and are valid for unmounted bearings under zero measuring load.
Misalignment	<ul style="list-style-type: none"> Guideline values for light to normal loads ($P \leq 0,1 C$) and constant position of misalignment with respect to the outer ring: (→ table 6, page 895) Whether these values can be fully exploited depends on the design of the bearing arrangement, the bearing abutments in the housing, etc. When the position of the misalignment is not constant with respect to the outer ring, additional sliding may occur in the bearing, limiting misalignment to a few tenths of a degree.
Friction, starting torque, power loss	Frictional moment, starting torque and power loss can be calculated as specified under <i>Friction</i> (→ page 97), or using the tools available online at skf.com/bearingcalculator .
Defect frequencies	Defect frequencies can be calculated using the tools available online at skf.com/bearingcalculator .

Bearings for vibratory applications

- like SKF Explorer and
- P5 bore diameter
 - P6 outside diameter

Examples are:

- vibrating screens with rotating imbalance and therefore rotating deflection of the shaft (→ **fig. 12**)
 - deflection-compensating rolls of paper machines where the stationary shaft is bent
- To avoid detrimental effects on sealing performance, misalignment for sealed bearings should not exceed 0,5°.

Table 3

Width tolerances for SKF Explorer spherical roller bearings

Bore diameter d		Width tolerances in accordance with SKF standard Δ_{B_s}	
over	incl.	high	low
mm		µm	
18	50	0	-60
50	80	0	-60
80	120	0	-80
120	180	0	-80
180	250	0	-80
250	300	0	-100

Fig. 12

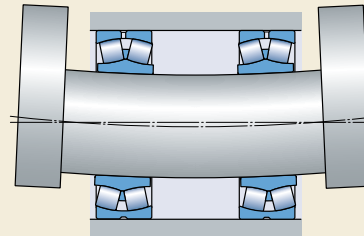

8 Spherical roller bearings

Table 4

Radial internal clearance of spherical roller bearings with a cylindrical bore

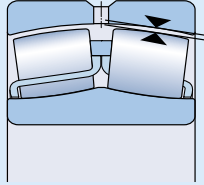

Bore diameter d		Radial internal clearance									
over	incl.	C2		Normal		C3		C4		C5	
		min.	max.	min.	max.	min.	max.	min.	max.	min.	max.
mm		µm									
18	24	10	20	20	35	35	45	45	60	60	75
24	30	15	25	25	40	40	55	55	75	75	95
30	40	15	30	30	45	45	60	60	80	80	100
40	50	20	35	35	55	55	75	75	100	100	125
50	65	20	40	40	65	65	90	90	120	120	150
65	80	30	50	50	80	80	110	110	145	145	185
80	100	35	60	60	100	100	135	135	180	180	225
100	120	40	75	75	120	120	160	160	210	210	260
120	140	50	95	95	145	145	190	190	240	240	300
140	160	60	110	110	170	170	220	220	280	280	350
160	180	65	120	120	180	180	240	240	310	310	390
180	200	70	130	130	200	200	260	260	340	340	430
200	225	80	140	140	220	220	290	290	380	380	470
225	250	90	150	150	240	240	320	320	420	420	520
250	280	100	170	170	260	260	350	350	460	460	570
280	315	110	190	190	280	280	370	370	500	500	630
315	355	120	200	200	310	310	410	410	550	550	690
355	400	130	220	220	340	340	450	450	600	600	750
400	450	140	240	240	370	370	500	500	660	660	820
450	500	140	260	260	410	410	550	550	720	720	900
500	560	150	280	280	440	440	600	600	780	780	1000
560	630	170	310	310	480	480	650	650	850	850	1100
630	710	190	350	350	530	530	700	700	920	920	1190
710	800	210	390	390	580	580	770	770	1010	1010	1300
800	900	230	430	430	650	650	860	860	1120	1120	1440
900	1000	260	480	480	710	710	930	930	1220	1220	1570
1000	1120	290	530	530	780	780	1020	1020	1330	1330	1720
1120	1250	320	580	580	860	860	1120	1120	1460	1460	1870
1250	1400	350	640	640	950	950	1240	1240	1620	1620	2060
1400	1600	400	720	720	1060	1060	1380	1380	1800	1800	2300
1600	1800	450	810	810	1180	1180	1550	1550	2000	2000	2550

Table 5

Radial internal clearance of spherical roller bearings with a tapered bore

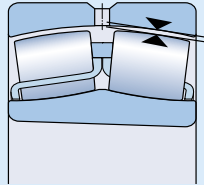

Bore diameter		Radial internal clearance									
d		C2		Normal		C3		C4		C5	
over	incl.	min.	max.	min.	max.	min.	max.	min.	max.	min.	max.
mm		µm									
24	30	20	30	30	40	40	55	55	75	–	–
30	40	25	35	35	50	50	65	65	85	85	105
40	50	30	45	45	60	60	80	80	100	100	130
50	65	40	55	55	75	75	95	95	120	120	160
65	80	50	70	70	95	95	120	120	150	150	200
80	100	55	80	80	110	110	140	140	180	180	230
100	120	65	100	100	135	135	170	170	220	220	280
120	140	80	120	120	160	160	200	200	260	260	330
140	160	90	130	130	180	180	230	230	300	300	380
160	180	100	140	140	200	200	260	260	340	340	430
180	200	110	160	160	220	220	290	290	370	370	470
200	225	120	180	180	250	250	320	320	410	410	520
225	250	140	200	200	270	270	350	350	450	450	570
250	280	150	220	220	300	300	390	390	490	490	620
280	315	170	240	240	330	330	430	430	540	540	680
315	355	190	270	270	360	360	470	470	590	590	740
355	400	210	300	300	400	400	520	520	650	650	820
400	450	230	330	330	440	440	570	570	720	720	910
450	500	260	370	370	490	490	630	630	790	790	1000
500	560	290	410	410	540	540	680	680	870	870	1100
560	630	320	460	460	600	600	760	760	980	980	1230
630	710	350	510	510	670	670	850	850	1090	1090	1360
710	800	390	570	570	750	750	960	960	1220	1220	1500
800	900	440	640	640	840	840	1070	1070	1370	1370	1690
900	1000	490	710	710	930	930	1190	1190	1520	1520	1860
1000	1120	530	770	770	1030	1030	1300	1300	1670	1670	2050
1120	1250	570	830	830	1120	1120	1420	1420	1830	1830	2250
1250	1400	620	910	910	1230	1230	1560	1560	2000	2000	2450
1400	1600	680	1000	1000	1350	1350	1720	1720	2200	2200	2700
1600	1800	750	1110	1110	1500	1500	1920	1920	2400	2400	2950

Loads

<p>Minimum load</p>	<p>$P_m = 0,01 C_0$</p> <p>Oil lubricated bearings:</p> <p>$n/n_r \leq 0,3 \quad \rightarrow \quad P_m = 0,003 C_0$</p> <p>$0,3 < n/n_r \leq 2 \quad \rightarrow \quad P_m = 0,003 C_0 \left(1 + 2 \sqrt{\frac{n}{n_r} - 0,3} \right)$</p>
<p>For additional information (→ page 86)</p>	<p>The weight of the components supported by the bearing, together with external forces, generally exceed the requisite minimum load. If this is not the case, the bearing must be subjected to an additional radial load.</p>
<p>Axial load carrying capacity</p>	<p>SKF spherical roller bearings are able to accommodate heavy axial loads and even purely axial loads.</p> <p>Bearings mounted on an adapter sleeve on smooth shafts without fixed abutment:</p> <p>$F_{ap} = 0,003 B d$</p> <p>Provided the bearings are correctly mounted.</p>
<p>Equivalent dynamic bearing load</p> <p>For additional information (→ page 85)</p>	<p>$F_a/F_r \leq e \quad \rightarrow \quad P = F_r + Y_1 F_a$</p> <p>$F_a/F_r > e \quad \rightarrow \quad P = 0,67 F_r + Y_2 F_a$</p>
<p>Equivalent static bearing load</p> <p>For additional information (→ page 88)</p>	<p>$P_0 = F_r + Y_0 F_a$</p>

Symbols

B	= bearing width [mm]
C_0	= basic static load rating [kN] (→ product tables)
d	= bearing bore diameter [mm]
e	= calculation factor (→ product tables)
F_a	= axial load [kN]
F_{ap}	= maximum permissible axial load [kN]
F_r	= radial load [kN]
P	= equivalent dynamic bearing load [kN]
P_0	= equivalent static bearing load [kN]
P_m	= equivalent minimum load [kN]
n	= rotational speed [r/min]
n_r	= reference speed [r/min] (→ product tables)
Y_0, Y_1, Y_2	= calculation factors (→ product tables)

Table 6

Permissible angular misalignment

Bearing series	Permissible angular misalignment
Sizes	
–	°
Series 213	2
Series 222	
Sizes < 52	2
Sizes ≥ 52	1,5
Series 223	3
Series 230	
Sizes < 56	2
Sizes ≥ 56	2,5
Series 231	
Sizes < 60	2
Sizes ≥ 60	3
Series 232	
Sizes < 52	2,5
Sizes ≥ 52	3,5
Series 238	1,5
Series 239	1,5
Series 240	2
Series 241	
Sizes < 64	2,5
Sizes ≥ 64	3,5
Series 248	1,5
Series 249	2,5

Temperature limits

The permissible operating temperature for spherical roller bearings can be limited by:

- the dimensional stability of the bearing rings
- the seals
- the lubricant

When temperatures outside the permissible range are expected, contact the SKF application engineering service.

Bearing rings

SKF spherical roller bearings undergo a special heat treatment. The bearings are heat stabilized for use at temperatures up to 200 °C (390 °F) for at least 2 500 h, or for brief periods at even higher temperatures.

Seals

The permissible operating temperature for seals depends on the material:

- NBR seals:
–40 to +90 °C (–40 to +195 °F)
Temperatures up to 120 °C (250 °F) can be tolerated for brief periods.
- HNBR seals:
–40 to +150 °C (–40 to +300 °F)
- FKM seals:
–30 to +200 °C (–20 to +390 °F)

Lubricants

Temperature limits for the greases used in SKF spherical roller bearings are provided in **table 1** (→ **page 885**) for sealed bearings and in **table 2** (→ **page 889**) for SKF E2 bearings. Temperature limits for other SKF greases are provided under *Lubrication* (→ **page 239**).

When using lubricants not supplied by SKF, the temperature limits should be evaluated according to the SKF traffic light concept (→ **page 244**).

Permissible speed

The permissible speed can be estimated using the speed ratings listed in the product tables and applying the information provided under *Speeds* (→ **page 117**). If no reference speed is listed in the product tables, the limiting speed is the permissible speed.

To achieve their special performance characteristics, SKF E2 spherical roller bearings must operate at speeds above the recommended minimum speed of 500 r/min.

Design of bearing arrangements

Free space on both sides of the bearing

To prevent interference between rotating and stationary components, the abutment diameter on the shaft should be $< d_2$ and in the housing $> D_1$ (→ **fig. 13**). Values for d_2 and D_1 are listed in the product tables.

The necessary width of the free space C_a depends on:

- the actual misalignment
- the possible protrusion of the cage from the side face of the bearing for some bearing sizes
- lubrication requirements

That requisite free space should be at least 20 times the minimum value of the radial internal clearance in the unmounted bearing (→ **table 4, page 892** or **table 5, page 893**).

For additional information, contact the SKF application engineering service.

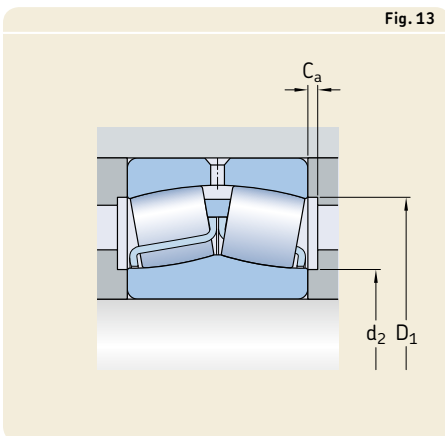

8 Spherical roller bearings

Abutments for sealed bearings

The diameter of the shaft abutment should not exceed $d_{a\max}$ (→ **product tables**) at least for the 1 to 2 mm closest to the bearing, to prevent interference with the seal (→ **fig. 14**). If the bearings are to be located axially on the shaft by a lock nut, SKF recommends using a KMFE lock nut (→ **fig. 15**) or a spacer ring (→ **fig. 16**) between the bearing and the lock washer to prevent interference with the seal.

Bearings on sleeves

Spherical roller bearings with a tapered bore can be mounted on plain or stepped shafts with an adapter sleeve (→ **fig. 17**) or on stepped shafts with a withdrawal sleeve (→ **fig. 18**). Adapter sleeves are supplied complete with a locking device. For additional information about sleeves, refer to *Bearing accessories* (→ **page 1269**).

When using sealed spherical roller bearings on an adapter sleeve, the locking device must not interfere with the seal. To avoid this, use an appropriate SKF adapter sleeve assembly for sealed bearings (→ **fig. 19**), as listed in the product tables (→ **page 954**). Alternatively, a spacer ring can be inserted between the bearing and the lock washer.

Fig. 14

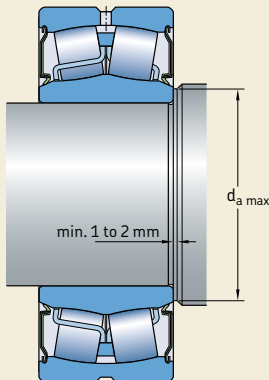

Fig. 15

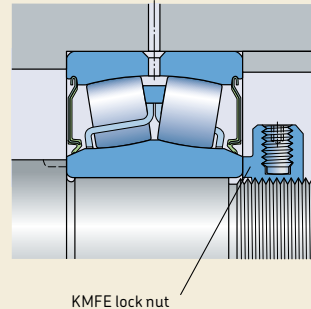

Fig. 16

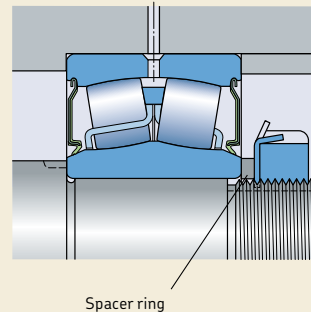
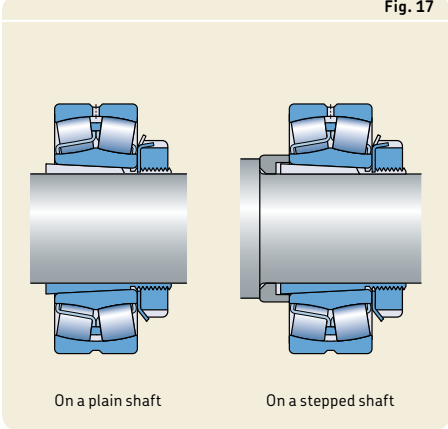

Fig. 17



Appropriate bearing housings

The combination of a spherical roller bearing, appropriate sleeve, where needed, and an appropriate SKF bearing housing provides a cost-effective, interchangeable and reliable solution that fulfils the demand for easy maintenance. Appropriate SKF housings are available in a variety of designs and sizes for a wide range of applications. The designs include:

- split and non-split plummer (pillow) block housings
- flanged housings
- take-up housings

Additional information about SKF bearing housings is available online at skf.com/housings.

Fig. 18

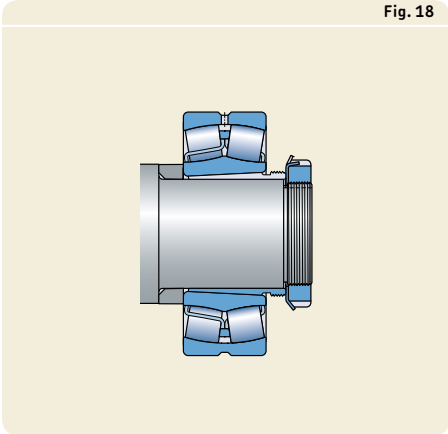
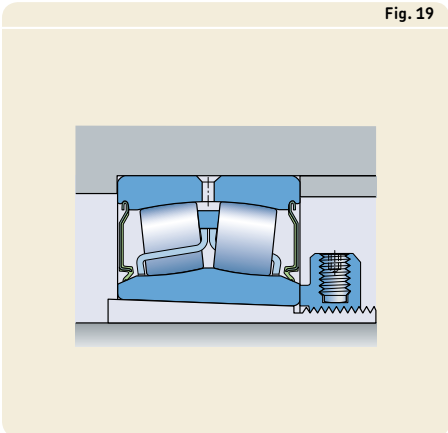

Fig. 19



8 Spherical roller bearings

Mounting

Due to the design of spherical roller bearings, the rings and roller complement may be displaced axially from the normal position during handling. Therefore, SKF recommends mounting spherical roller bearings when the shaft or housing is in the horizontal position. Also, whenever possible, rotate the inner or outer ring to align the rollers during mounting.

If spherical roller bearings are mounted when the shaft or housing is in the vertical position, the roller complement, together with the inner or outer ring will move downward until there is no more clearance. Then, when the bearing rings expand or contract as a result of an interference fit, a preload is likely to result. To prevent this preload condition from occurring, rotate the inner or outer ring during installation. If this is not feasible, use a bearing handling tool or other device to keep the bearing components arranged centrally.

Mounting bearings with a tapered bore

Bearings with a tapered bore are always mounted with an interference fit. To obtain the proper degree of interference, one of the following methods can be used:

- 1 measuring the clearance reduction
- 2 measuring the lock nut tightening angle
- 3 measuring the axial drive-up
- 4 applying the SKF Drive-up Method
- 5 measuring the inner ring expansion (SensorMount)

For additional information about these mounting methods, refer to *Mounting, dismounting and bearing care* (→ **page 271**), or the *SKF bearing maintenance handbook*.

For bearings with $d > 100$ mm, SKF recommends using the SKF Drive-up Method. This is a fast, reliable and safe method to achieve the appropriate interference fit. Additional information is available online at skf.com/drive-up.

Recommended values to apply methods 1 to 3 are listed in **table 7**.

Table 7

Drive-up data for spherical roller bearings with a tapered bore

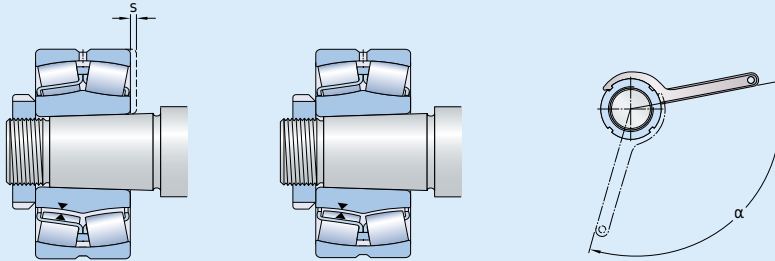

Bore diameter d		Reduction of radial internal clearance		Axial drive-up ¹⁾²⁾ s				Lock nut tightening angle ²⁾ α
over	incl.	min.	max.	Taper 1:12		Taper 1:30		Taper 1:12
mm	mm	mm	mm	min.	max.	min.	max.	°
24	30	0,010	0,015	0,25	0,29	–	–	100
30	40	0,015	0,020	0,30	0,35	–	–	115
40	50	0,020	0,025	0,37	0,44	–	–	130
50	65	0,025	0,035	0,45	0,54	1,15	1,35	115
65	80	0,035	0,040	0,55	0,65	1,40	1,65	130
80	100	0,040	0,050	0,66	0,79	1,65	2,00	150
100	120	0,050	0,060	0,79	0,95	2,00	2,35	
120	140	0,060	0,075	0,93	1,10	2,30	2,80	
140	160	0,070	0,085	1,05	1,30	2,65	3,20	
160	180	0,080	0,095	1,20	1,45	3,00	3,60	
180	200	0,090	0,105	1,30	1,60	3,30	4,00	
200	225	0,100	0,120	1,45	1,80	3,70	4,45	
225	250	0,110	0,130	1,60	1,95	4,00	4,85	
250	280	0,120	0,150	1,80	2,15	4,50	5,40	
280	315	0,135	0,165	2,00	2,40	4,95	6,00	
315	355	0,150	0,180	2,15	2,65	5,40	6,60	
355	400	0,170	0,210	2,50	3,00	6,20	7,60	
400	450	0,195	0,235	2,80	3,40	7,00	8,50	
450	500	0,215	0,265	3,10	3,80	7,80	9,50	
500	560	0,245	0,300	3,40	4,10	8,40	10,30	
560	630	0,275	0,340	3,80	4,65	9,50	11,60	
630	710	0,310	0,380	4,25	5,20	10,60	13,00	
710	800	0,350	0,425	4,75	5,80	11,90	14,50	
800	900	0,395	0,480	5,40	6,60	13,50	16,40	
900	1 000	0,440	0,535	6,00	7,30	15,00	18,30	
1 000	1 120	0,490	0,600	6,40	7,80	16,00	19,50	
1 120	1 250	0,550	0,670	7,10	8,70	17,80	21,70	
1 250	1 400	0,610	0,750	8,00	9,70	19,90	24,30	
1 400	1 600	0,700	0,850	9,10	11,10	22,70	27,70	
1 600	1 800	0,790	0,960	10,20	12,50	25,60	31,20	

NOTE: Applying the recommended values prevents the inner ring from creeping, but does not ensure correct radial internal clearance in operation. Additional influences from the bearing housing fit and temperature differences between the inner and outer rings must be considered carefully when selecting the bearing radial internal clearance class. For additional information, contact the SKF application engineering service.

Valid only for solid steel shafts and general applications.

¹⁾ Not valid for the SKF Drive-up Method.

²⁾ The listed values are to be used as guideline values only, as it is difficult to establish an exact starting position. Also, the axial drive-up s differs slightly between the different bearings series.

Designation system

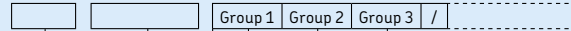

Prefixes

BS2-..	Bearing, designated by a drawing number
E2.	SKF Energy Efficient bearing
ZE	Bearing with SensorMount feature

Basic designation

Listed in **diagram 2** (→ **page 43**)
Figure with four digits: drawing number identification

Suffixes

Group 1: Internal design

CA, CAC	Retaining flanges on the inner ring, guide ring centred on the inner ring, machined brass cage
CC(J), CJ	Flangeless inner ring, guide ring centred on the inner ring, two stamped steel cages
CCJA, EJA	Flangeless inner ring, guide ring centred on the outer ring raceway, two stamped steel cages
E	Optimized internal design for increased load carrying capacity 213, 222 and 223 series: Flangeless inner ring and two stamped steel cages. Annular groove and three lubrication holes in the outer ring. d ≤ 65 mm: Guide ring centred on the inner ring d > 65 mm: Guide ring centred on the cage

Group 2: External design (seals, snap ring groove etc.)

-CS, -2CS	Contact seal, NBR, on one or both sides
-CS2, -2CS2	Contact seal, FKM, on one or both sides
-CS5, -2CS5	Contact seal, HNBR, on one or both sides
K	Tapered bore, taper 1:12
K30	Tapered bore, taper 1:30

Group 3: Cage design

F	Machined steel cage, inner ring centred
FA	Machined steel cage, outer ring centred
J	Stamped steel cage, inner ring centred
JA	Stamped steel cage, outer ring centred
MA	Machined brass cage, outer ring centred

Group 4					
4.1	4.2	4.3	4.4	4.5	4.6

Group 4.6: Other variants

- VA405** Bearing for vibratory applications, surface-hardened stamped steel cages
- VA406** Same as VA405, but PTFE coated cylindrical inner ring bore
- VE552(E)** Outer ring with three equally spaced threaded holes in one side face to accommodate lifting tackle. The E indicates that appropriate eye bolts are supplied with the bearing.
- VE553(E)** Same as VE552(E), but threaded holes in both side faces
- VG114** Surface-hardened stamped steel cages
- VQ424** Running accuracy better than C08

Group 4.5: Lubrication

- GEM9** Filled to 70 – 100% with SKF LGHB 2 grease
- VT143** Filled to 25 – 45% with SKF LGEP 2 grease
- VT143B** Filled to 45 – 60% with SKF LGEP 2 grease
- VT143C** Filled to 70 – 100% with SKF LGEP 2 grease
- W64** Solid Oil
- W** Without annular groove and lubrication holes in the outer ring
- W20** Three lubrication holes in the outer ring
- W26** Six lubrication holes in the inner ring
- W33** Annular groove and three lubrication holes in the outer ring
- W33X** Annular groove and six lubrication holes in the outer ring
- W77** Plugged W33 lubrication holes
- W513** W26 + W33

Group 4.4: Stabilization

Group 4.3: Bearing sets, matched bearings

Group 4.2: Accuracy, clearance, preload, quiet running

- C08** Running accuracy to P5 tolerance class
- C083** C08 + C3
- C084** C08 + C4
- C2** Radial internal clearance smaller than Normal
- C3** Radial internal clearance greater than Normal
- C4** Radial internal clearance greater than C3
- C5** Radial internal clearance greater than C4
- P5** Dimensional and running accuracy to P5 tolerance class
- P6** Dimensional and running accuracy to P6 tolerance class
- P62** P6 + C2

Group 4.1: Materials, heat treatment

- 235220** Case-hardened inner ring with a helical groove in the bore
- HA3** Case-hardened inner ring

8.1 Spherical roller bearings d 20 – 60 mm

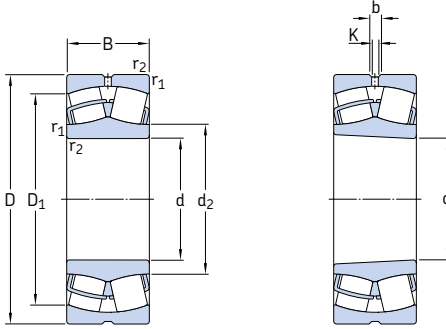

Cylindrical bore

Tapered bore

Principal dimensions		Basic load ratings		Fatigue load limit P_u	Speed ratings		Mass kg	Designations Bearing with cylindrical bore	Designations Bearing with tapered bore	
d	D	dynamic C	static C_0		Reference speed	Limiting speed				
mm	mm	kN	kN	kN	r/min	r/min	kg	–	–	
20	52	18	49	44	4,75	13 000	17 000	0,28	* 22205/20 E	–
25	52	18	49	44	4,75	13 000	17 000	0,26	* 22205 E	* 22205 EK
	62	17	48	41,5	4,55	9 300	12 000	0,28	* 21305 CC	–
30	62	20	64	60	6,4	10 000	14 000	0,29	* 22206 E	* 22206 EK
	72	19	64	61	6,8	8 200	10 000	0,41	* 21306 CC	* 21306 CCK
35	72	23	86,5	85	9,3	9 000	12 000	0,45	* 22207 E	* 22207 EK
	80	21	76,5	72	8,15	7 300	9 500	0,55	* 21307 CC	* 21307 CCK
40	80	23	96,5	90	9,8	8 000	11 000	0,53	* 22208 E	* 22208 EK
	90	23	104	108	11,8	7 000	9 500	0,75	* 21308 E	* 21308 EK
	90	33	150	140	15	6 000	8 000	1,05	* 22308 E	* 22308 EK
45	85	23	102	98	10,8	7 500	10 000	0,58	* 22209 E	* 22209 EK
	85	23	96,5	93	9,65	11 000	10 000	0,58	E2.22209 ¹⁾	E2.22209 K ¹⁾
	100	25	125	127	13,7	6 300	8 500	0,99	* 21309 E	* 21309 EK
	100	36	183	183	19,6	5 300	7 000	1,4	* 22309 E	* 22309 EK
50	90	23	104	108	11,8	7 000	9 500	0,63	* 22210 E	* 22210 EK
	90	23	100	102	10,8	10 000	9 500	0,63	E2.22210 ¹⁾	E2.22210 K ¹⁾
	110	27	156	166	18,6	5 600	7 500	1,35	* 21310 E	* 21310 EK
	110	40	220	224	24	4 800	6 300	1,9	* 22310 E	* 22310 EK
55	100	25	125	127	13,7	6 300	8 500	0,84	* 22211 E	* 22211 EK
	100	25	120	120	12,5	9 000	8 500	0,84	E2.22211 ¹⁾	E2.22211 K ¹⁾
	120	29	156	166	18,6	5 600	7 500	1,7	* 21311 E	* 21311 EK
	120	43	270	280	30	4 300	5 600	2,45	* 22311 E	* 22311 EK
60	110	28	156	166	18,6	5 600	7 500	1,15	* 22212 E	* 22212 EK
	110	28	150	156	16,6	8 000	7 500	1,15	E2.22212 ¹⁾	E2.22212 K ¹⁾
	130	31	212	240	26,5	4 800	6 300	2,1	* 21312 E	* 21312 EK
	130	46	310	335	36,5	4 000	5 300	3,1	* 22312 E	* 22312 EK

¹⁾ Recommended speed > 500 r/min

* SKF Explorer bearing

E2 → SKF Energy Efficient bearing

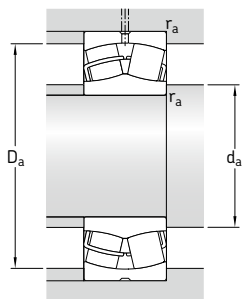

Dimensions						Abutment and fillet dimensions			Calculation factors			
d	d ₂	D ₁	b	K	r _{1,2} min.	d _a min.	D _a max.	r _a max.	e	Y ₁	Y ₂	Y ₀
mm						mm			-			
20	31,3	44,2	3,7	2	1	25,6	46,4	1	0,35	1,9	2,9	1,8
25	31,3 35,7	44,2 50,7	3,7 -	2 -	1 1,1	30,6 32	46,4 55	1 1	0,35 0,3	1,9 2,3	2,9 3,4	1,8 2,2
30	37,6 43,3	53 58,8	3,7 -	2 -	1 1,1	35,6 37	56,4 65	1 1	0,31 0,27	2,2 2,5	3,3 3,7	2,2 2,5
35	44,5 47,2	61,8 65,6	3,7 -	2 -	1,1 1,5	42 44	65 71	1 1,5	0,31 0,28	2,2 2,4	3,3 3,6	2,2 2,5
40	49,6 60 49,9	69,4 79,8 74,3	6 5,5 6	3 3 3	1,1 1,5 1,5	47 49 49	73 81 81	1 1,5 1,5	0,28 0,24 0,37	2,4 2,8 1,8	3,6 4,2 2,7	2,5 2,8 1,8
45	54,4 54,4 65,3 57,6	74,4 74,4 88 83,4	5,5 5,5 6 6	3 3 3 3	1,1 1,1 1,5 1,5	52 52 54 54	78 78 91 91	1 1 1,5 1,5	0,26 0,26 0,24 0,37	2,6 2,6 2,8 1,8	3,9 3,9 4,2 2,7	2,5 2,5 2,8 1,8
50	60 59,9 72,7 63,9	79 79 96,8 91,9	5,5 5,5 6 6	3 3 3 3	1,1 1,1 2 2	57 57 61 61	83 83 99 99	1 1 2 2	0,24 0,24 0,24 0,37	2,8 2,8 2,8 1,8	4,2 4,2 4,2 2,7	2,8 2,8 2,8 1,8
55	65,3 65,3 72,7 70,1	88 88 96,2 102	6 6 6 5,5	3 3 3 3	1,5 1,5 2 2	64 64 66 66	91 91 109 109	1,5 1,5 2 2	0,24 0,24 0,24 0,35	2,8 2,8 2,8 1,9	4,2 4,2 4,2 2,9	2,8 2,8 2,8 1,8
60	72,7 71,6 87,8 77,9	96,5 96,5 115 110	6 6 6 8,3	3 3 3 4,5	1,5 1,5 2,1 2,1	69 69 72 72	101 101 118 118	1,5 1,5 2 2	0,24 0,24 0,22 0,35	2,8 2,8 3 1,9	4,2 4,2 4,6 2,9	2,8 2,8 2,8 1,8

8.1 Spherical roller bearings d 65 – 95 mm

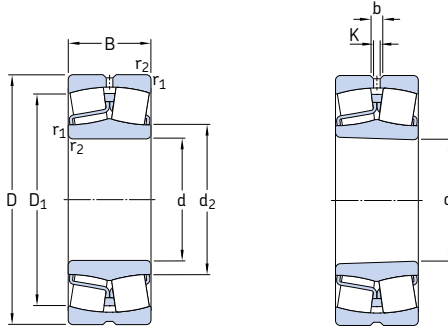

Cylindrical bore

Tapered bore

Principal dimensions		Basic load ratings		Fatigue load limit P_u	Speed ratings		Mass kg	Designations		
d	D	dynamic C	static C_0		Reference speed	Limiting speed		Bearing with cylindrical bore	tapered bore	
mm	mm	kN	kN	kN	r/min	r/min	kg	–	–	
65	100	35	132	173	20,4	4 300	6 300	0,95	* 24013 CC/W33	* 24013 CCK30/W33
	120	31	193	216	24	5 000	7 000	1,55	* 22213 E	* 22213 EK
	120	31	168	204	21,2	7 000	7 000	1,55	E2, 22213 ¹⁾	E2, 22213 K ¹⁾
	140	33	236	270	29	4 300	6 000	2,55	* 21313 E	* 21313 EK
	140	48	340	360	38	3 800	5 000	3,75	* 22313 E	* 22313 EK
70	125	31	208	228	25,5	5 000	6 700	1,55	* 22214 E	* 22214 EK
	150	35	285	325	34,5	4 000	5 600	3,1	* 21314 E	* 21314 EK
	150	51	400	430	45	3 400	4 500	4,55	* 22314 E	* 22314 EK
75	115	40	173	232	28,5	3 800	5 300	1,55	* 24015 CC/W33	* 24015 CCK30/W33
	130	31	212	240	26,5	4 800	6 300	1,7	* 22215 E	* 22215 EK
	160	37	285	325	34,5	4 000	5 600	3,75	* 21315 E	* 21315 EK
	160	55	440	475	48	3 200	4 300	5,55	* 22315 E	* 22315 EK
80	140	33	236	270	29	4 300	6 000	2,1	* 22216 E	* 22216 EK
	170	39	325	375	39	3 800	5 300	4,45	* 21316 E	* 21316 EK
	170	58	490	540	54	3 000	4 000	6,6	* 22316 E	* 22316 EK
85	150	36	285	325	34,5	4 000	5 600	2,7	* 22217 E	* 22217 EK
	180	41	325	375	39	3 800	5 300	5,2	* 21317 E	* 21317 EK
	180	60	550	620	61	2 800	3 800	7,65	* 22317 E	* 22317 EK
90	160	40	325	375	39	3 800	5 300	3,4	* 22218 E	* 22218 EK
	160	52,4	355	440	48	2 800	3 800	4,65	* 23218 CC/W33	* 23218 CCK/W33
	190	43	380	450	46,5	3 600	4 800	6,1	* 21318 E	* 21318 EK
	190	64	610	695	67	2 600	3 600	9,05	* 22318 E	* 22318 EK
95	170	43	380	450	46,5	3 600	4 800	4,15	* 22219 E	* 22219 EK
	200	45	425	490	49	3 400	4 500	7,05	* 21319 E	* 21319 EK
	200	67	670	765	73,5	2 600	3 400	10,5	* 22319 E	* 22319 EK

¹⁾ Recommended speed > 500 r/min

* SKF Explorer bearing

E2 → SKF Energy Efficient bearing

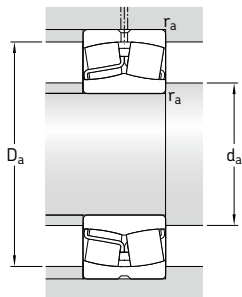

Dimensions						Abutment and fillet dimensions			Calculation factors			
d	d ₂	D ₁	b	K	r _{1,2} min.	d _a min.	D _a max.	r _a max.	e	Y ₁	Y ₂	Y ₀
mm						mm			-			
65	73,9	87,3	3,7	2	1,1	71	94	1	0,27	2,5	3,7	2,5
	80,1	106	6	3	1,5	74	111	1,5	0,24	2,8	4,2	2,8
	77,6	106	6	3	1,5	74	111	1,5	0,24	2,8	4,2	2,8
	94,7	124	6	3	2,1	77	128	2	0,22	3	4,6	2,8
	81,6	118	8,3	4,5	2,1	77	128	2	0,35	1,9	2,9	1,8
70	83	111	6	3	1,5	79	116	1,5	0,23	2,9	4,4	2,8
	101	133	6	3	2,1	82	138	2	0,22	3	4,6	2,8
	90,3	128	8,3	4,5	2,1	82	138	2	0,33	2	3	2
75	84,2	100	5,5	3	1,1	81	109	1	0,28	2,4	3,6	2,5
	87,8	115	6	3	1,5	84	121	1,5	0,22	3	4,6	2,8
	101	133	6	3	2,1	87	148	2	0,22	3	4,6	2,8
	92,8	135	8,3	4,5	2,1	87	148	2	0,35	1,9	2,9	1,8
80	94,7	124	6	3	2	91	129	2	0,22	3	4,6	2,8
	106	141	6	3	2,1	92	158	2	0,24	2,8	4,2	2,8
	98,3	143	8,3	4,5	2,1	92	158	2	0,35	1,9	2,9	1,8
85	101	133	6	3	2	96	139	2	0,22	3	4,6	2,8
	106	141	6	3	3	99	166	2,5	0,24	2,8	4,2	2,8
	108	154	8,3	4,5	3	99	166	2,5	0,33	2	3	2
90	106	141	6	3	2	101	149	2	0,24	2,8	4,2	2,8
	106	137	5,5	3	2	101	149	2	0,31	2,2	3,3	2,2
	112	150	8,3	4,5	3	104	176	2,5	0,24	2,8	4,2	2,8
	113	161	11,1	6	3	104	176	2,5	0,33	2	3	2
95	112	150	8,3	4,5	2,1	107	158	2	0,24	2,8	4,2	2,8
	118	159	8,3	4,5	3	109	186	2,5	0,24	2,8	4,2	2,8
	118	168	11,1	6	3	109	186	2,5	0,33	2	3	2

8.1 Spherical roller bearings d 100 – 130 mm

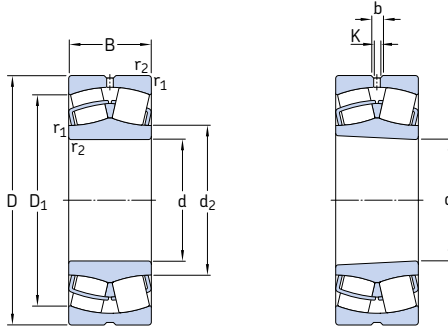

Cylindrical bore

Tapered bore

Principal dimensions	Basic load ratings	Fatigue load limit	Speed ratings		Mass	Designations	Designations											
			dynamic	static				Reference speed	Limiting speed	Bearing with cylindrical bore	tapered bore							
d	D	B	C	C ₀	P _u													
mm			kN	kN	kN	r/min	r/min	kg										
100	150	50	285	415	45,5	2 800	4 000	3,15	*	24020 CC/W33	*	24020 CCK30/W33						
	165	52	365	490	53	3 000	4 000	4,55	*	23120 CC/W33	*	23120 CCK/W33						
	165	65	455	640	68	2 400	3 200	5,65	*	24120 CC/W33	*	24120 CCK30/W33						
	180	46	425	490	49	3 400	4 500	4,9	*	22220 E	*	22220 EK						
	180	60,3	475	600	63	2 400	3 400	6,85	*	23220 CC/W33	*	23220 CCK/W33						
	215	47	425	490	49	3 400	4 500	8,6	*	21320 E	*	21320 EK						
110	170	45	310	440	46,5	3 400	4 300	3,8	*	23022 CC/W33	*	23022 CCK/W33						
	170	60	415	620	67	2 400	3 600	5	*	24022 CC/W33	*	24022 CCK30/W33						
	180	56	430	585	61	2 800	3 600	5,75	*	23122 CC/W33	*	23122 CCK/W33						
	180	69	520	750	78	2 000	3 000	7,1	*	24122 CC/W33	*	24122 CCK30/W33						
	200	53	560	640	63	3 000	4 000	7	*	22222 E	*	22222 EK						
	200	69,8	600	765	76,5	2 200	3 200	9,85	*	23222 CC/W33	*	23222 CCK/W33						
120	180	46	355	510	53	3 200	4 000	4,2	*	23024 CC/W33	*	23024 CCK/W33						
	180	60	430	670	68	2 400	3 400	5,45	*	24024 CC/W33	*	24024 CCK30/W33						
	200	62	510	695	71	2 600	3 400	8	*	23124 CC/W33	*	23124 CCK/W33						
	200	80	655	950	95	1 900	2 600	10,5	*	24124 CC/W33	*	24124 CCK30/W33						
	215	58	630	765	73,5	2 800	3 800	8,7	*	22224 E	*	22224 EK						
	215	76	695	930	93	2 000	2 800	12	*	23224 CC/W33	*	23224 CCK/W33						
130	200	52	430	610	62	2 800	3 600	6	*	23026 CC/W33	*	23026 CCK/W33						
	200	69	540	815	81,5	2 000	3 000	8,05	*	24026 CC/W33	*	24026 CCK30/W33						
	210	64	560	780	78	2 400	3 200	8,8	*	23126 CC/W33	*	23126 CCK/W33						
	210	80	680	1 000	100	1 700	2 400	11	*	24126 CC/W33	*	24126 CCK30/W33						
	230	64	735	930	88	2 600	3 600	11	*	22226 E	*	22226 EK						
	230	80	780	1 060	104	1 900	2 600	14,5	*	23226 CC/W33	*	23226 CCK/W33						
280	93	1 120	1 320	114	1 800	2 400	29	*	22326 CC/W33	*	22326 CCK/W33							

* SKF Explorer bearing

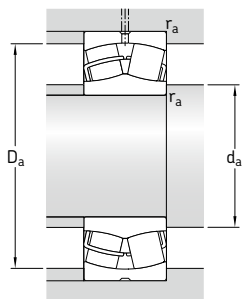

Dimensions						Abutment and fillet dimensions			Calculation factors			
d	d ₂	D ₁	b	K	r _{1,2} min.	d _a min.	D _a max.	r _a max.	e	Y ₁	Y ₂	Y ₀
mm						mm			-			
100	111	132	6	3	1,5	107	143	1,5	0,28	2,4	3,6	2,5
	115	144	6	3	2	111	154	2	0,3	2,3	3,4	2,2
	113	141	4,4	2	2	111	154	2	0,37	1,8	2,7	1,8
	118	159	8,3	4,5	2,1	112	168	2	0,24	2,8	4,2	2,8
	117	153	8,3	4,5	2,1	112	168	2	0,33	2	3	2
	118	159	8,3	4,5	3	114	201	2,5	0,24	2,8	4,2	2,8
130	184	11,1	6	3	3	114	201	2,5	0,33	2	3	2
110	125	151	6	3	2	119	161	2	0,23	2,9	4,4	2,8
	122	149	5,5	3	2	119	161	2	0,33	2	3	2
	126	157	8,3	4,5	2	121	169	2	0,3	2,3	3,4	2,2
	123	153	6	3	2	121	169	2	0,37	1,8	2,7	1,8
	130	178	8,3	4,5	2,1	122	188	2	0,25	2,7	4	2,5
	130	169	8,3	4,5	2,1	122	188	2	0,33	2	3	2
143	204	13,9	7,5	3	3	124	226	2,5	0,33	2	3	2
120	135	163	6	3	2	129	171	2	0,22	3	4,6	2,8
	132	159	6	3	2	129	171	2	0,3	2,3	3,4	2,2
	139	174	8,3	4,5	2	131	189	2	0,28	2,4	3,6	2,5
	135	168	6	3	2	131	189	2	0,37	1,8	2,7	1,8
	141	189	11,1	6	2,1	132	203	2	0,26	2,6	3,9	2,5
	141	182	8,3	4,5	2,1	132	203	2	0,35	1,9	2,9	1,8
152	216	13,9	7,5	3	3	134	246	2,5	0,35	1,9	2,9	1,8
130	148	180	8,3	4,5	2	139	191	2	0,23	2,9	4,4	2,8
	145	175	6	3	2	139	191	2	0,31	2,2	3,3	2,2
	148	184	8,3	4,5	2	141	199	2	0,28	2,4	3,6	2,5
	146	180	6	3	2	141	199	2	0,35	1,9	2,9	1,8
	152	201	11,1	6	3	144	216	2,5	0,27	2,5	3,7	2,5
	151	196	8,3	4,5	3	144	216	2,5	0,33	2	3	2
164	233	16,7	9	4	4	147	263	3	0,35	1,9	2,9	1,8

8.1 Spherical roller bearings d 140 – 170 mm

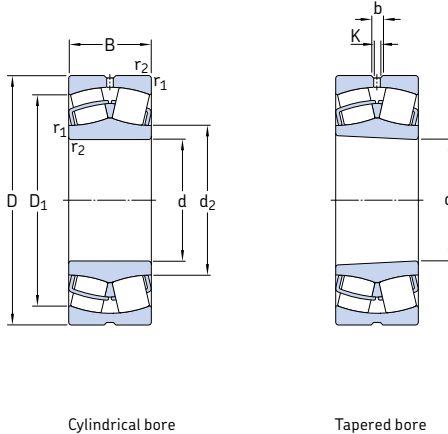

Principal dimensions		Basic load ratings		Fatigue load limit	Speed ratings		Mass	Designations			
d	D	B	dynamic C	static C ₀	P _u	Reference speed	Limiting speed	kg	Bearing with cylindrical bore	tapered bore	
mm			kN		kN	r/min			–		
140	210	53	465	680	68	2 600	3 400	6,55	* 23028 CC/W33	* 23028 CCK/W33	
	210	69	570	900	88	2 000	2 800	8,55	* 24028 CC/W33	* 24028 CCK30/W33	
	225	68	630	900	88	2 200	2 800	10,5	* 23128 CC/W33	* 23128 CCK/W33	
	225	85	765	1 160	112	1 600	2 200	13,5	* 24128 CC/W33	* 24128 CCK30/W33	
	250	68	710	900	86,5	2 400	3 200	14	* 22228 CC/W33	* 22228 CCK/W33	
	250	88	915	1 250	120	1 700	2 400	19	* 23228 CC/W33	* 23228 CCK/W33	
	300	102	1 290	1 560	132	1 700	2 200	36,5	* 22328 CC/W33	* 22328 CCK/W33	
	150	225	56	510	750	73,5	2 400	3 200	7,95	* 23030 CC/W33	* 23030 CCK/W33
		225	75	655	1 040	100	1 800	2 600	10,5	* 24030 CC/W33	* 24030 CCK30/W33
		250	80	830	1 200	114	2 000	2 600	16	* 23130 CC/W33	* 23130 CCK/W33
250		100	1 020	1 530	146	1 400	2 000	20	* 24130 CC/W33	* 24130 CCK30/W33	
270		73	850	1 080	102	2 200	3 000	18	* 22230 CC/W33	* 22230 CCK/W33	
270		96	1 080	1 460	137	1 600	2 200	24,5	* 23230 CC/W33	* 23230 CCK/W33	
320		108	1 460	1 760	146	1 600	2 000	43,5	* 22330 CC/W33	* 22330 CCK/W33	
160	240	60	585	880	83	2 400	3 000	9,7	* 23032 CC/W33	* 23032 CCK/W33	
	240	80	750	1 200	114	1 700	2 400	13	* 24032 CC/W33	* 24032 CCK30/W33	
	270	86	980	1 370	129	1 900	2 400	20,5	* 23132 CC/W33	* 23132 CCK/W33	
	270	109	1 180	1 760	163	1 300	1 900	25	* 24132 CC/W33	* 24132 CCK30/W33	
	290	80	1 000	1 290	118	2 000	2 800	22,5	* 22232 CC/W33	* 22232 CCK/W33	
	340	114	1 600	1 960	160	1 500	1 900	52	* 23232 CC/W33	* 23232 CCK/W33	
170	260	67	710	1 060	100	2 200	2 800	13	* 23034 CC/W33	* 23034 CCK/W33	
	260	90	930	1 460	137	1 600	2 400	17,5	* 24034 CC/W33	* 24034 CCK30/W33	
	280	88	1 040	1 500	137	1 800	2 400	22	* 23134 CC/W33	* 23134 CCK/W33	
	280	109	1 220	1 860	170	1 200	1 800	27,5	* 24134 CC/W33	* 24134 CCK30/W33	
	310	86	1 120	1 460	132	1 900	2 600	28,5	* 22234 CC/W33	* 22234 CCK/W33	
	360	120	1 760	2 160	176	1 400	1 800	61	* 23234 CC/W33	* 23234 CCK/W33	

* SKF Explorer bearing

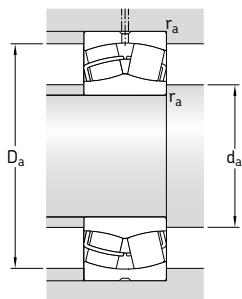

Dimensions					Abutment and fillet dimensions			Calculation factors				
d	d ₂	D ₁	b	K	r _{1,2} min.	d _a min.	D _a max.	r _a max.	e	Y ₁	Y ₂	Y ₀
mm						mm			-			
140	158	190	8,3	4,5	2	149	201	2t	0,22	3	4,6	2,8
	155	185	6	3	2	149	201	2	0,3	2,3	3,4	2,2
	159	197	8,3	4,5	2,1	152	213	2	0,28	2,4	3,6	2,5
	156	193	8,3	4,5	2,1	152	213	2	0,35	1,9	2,9	1,8
	166	216	11,1	6	3	154	236	2,5	0,26	2,6	3,9	2,5
150	165	212	11,1	6	3	154	236	2,5	0,33	2	3	2
	175	247	16,7	9	4	157	283	3	0,35	1,9	2,9	1,8
	169	203	8,3	4,5	2,1	161	214	2	0,22	3	4,6	2,8
160	165	197	6	3	2,1	161	214	2	0,3	2,3	3,4	2,2
	172	216	11,1	6	2,1	162	238	2	0,3	2,3	3,4	2,2
	169	211	8,3	4,5	2,1	162	238	2	0,37	1,8	2,7	1,8
	178	234	13,9	7,5	3	164	256	2,5	0,26	2,6	3,9	2,5
	175	228	11,1	6	3	164	256	2,5	0,35	1,9	2,9	1,8
170	188	266	16,7	9	4	167	303	3	0,35	1,9	2,9	1,8
	180	217	11,1	6	2,1	171	229	2	0,22	3	4,6	2,8
	176	211	8,3	4,5	2,1	171	229	2	0,3	2,3	3,4	2,2
	184	234	13,9	7,5	2,1	172	258	2	0,3	2,3	3,4	2,2
	181	228	8,3	4,5	2,1	172	258	2	0,4	1,7	2,5	1,6
160	191	250	13,9	7,5	3	174	276	2,5	0,26	2,6	3,9	2,5
	188	244	13,9	7,5	3	174	276	2,5	0,35	1,9	2,9	1,8
	200	282	16,7	9	4	177	323	3	0,35	1,9	2,9	1,8
170	191	232	11,1	6	2,1	181	249	2	0,23	2,9	4,4	2,8
	188	226	8,3	4,5	2,1	181	249	2	0,33	2	3	2
	195	244	13,9	7,5	2,1	182	268	2	0,3	2,3	3,4	2,2
	190	237	8,3	4,5	2,1	182	268	2	0,37	1,8	2,7	1,8
	203	267	16,7	9	4	187	293	3	0,27	2,5	3,7	2,5
170	200	261	13,9	7,5	4	187	293	3	0,35	1,9	2,9	1,8
	213	300	16,7	9	4	187	343	3	0,33	2	3	2

8.1 Spherical roller bearings d 180 – 220 mm

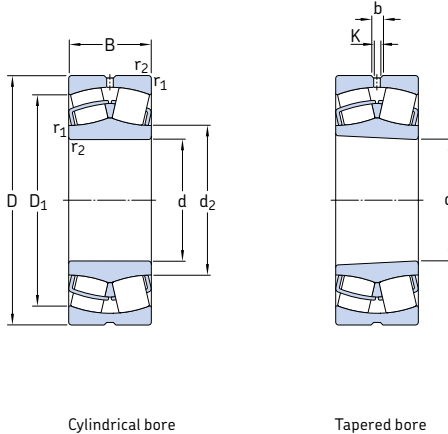

Cylindrical bore

Tapered bore

Principal dimensions	Basic load ratings	Fatigue load limit	Speed ratings		Mass	Designations	Designations												
			dynamic	static				Reference speed	Limiting speed	Bearing with cylindrical bore	tapered bore								
d	D	B	C	C ₀	P _u														
mm			kN	kN	r/min	kg													
180	250	52	490	830	76,5	2 600	2 800	7,9	*	23936 CC/W33	* 23936 CCK/W33								
	280	74	830	1 250	114	2 000	2 600	17	*	23036 CC/W33	* 23036 CCK/W33								
	280	100	1 080	1 730	156	1 500	2 200	23	*	24036 CC/W33	* 24036 CCK30/W33								
	300	96	1 200	1 760	160	1 700	2 200	28	*	23136 CC/W33	* 23136 CCK/W33								
	300	118	1 400	2 160	196	1 100	1 600	34,5	*	24136 CC/W33	* 24136 CCK30/W33								
	320	86	1 180	1 560	140	1 800	2 600	29,5	*	22236 CC/W33	* 22236 CCK/W33								
	320	112	1 500	2 120	186	1 300	1 900	39,5	*	23236 CC/W33	* 23236 CCK/W33								
	380	126	2 000	2 450	193	1 300	1 700	71,5	*	22336 CC/W33	* 22336 CCK/W33								
	190	260	52	475	800	76,5	2 400	2 600	8,3	*	23938 CC/W33	* 23938 CCK/W33							
290		75	865	1 340	122	1 900	2 400	18	*	23038 CC/W33	* 23038 CCK/W33								
290		100	1 120	1 800	163	1 400	2 000	24,5	*	24038 CC/W33	* 24038 CCK30/W33								
320		104	1 370	2 080	183	1 500	2 000	35	*	23138 CC/W33	* 23138 CCK/W33								
320		128	1 600	2 500	212	1 100	1 500	43	*	24138 CC/W33	* 24138 CCK30/W33								
340		92	1 270	1 700	150	1 700	2 400	36,5	*	22238 CC/W33	* 22238 CCK/W33								
340		120	1 660	2 400	208	1 300	1 800	48	*	23238 CC/W33	* 23238 CCK/W33								
400		132	2 120	2 650	208	1 200	1 600	82,5	*	22338 CC/W33	* 22338 CCK/W33								
200		280	60	620	1 040	93	2 200	2 400	11,5	*	23940 CC/W33	* 23940 CCK/W33							
	310	82	1 000	1 530	137	1 800	2 200	23,5	*	23040 CC/W33	* 23040 CCK/W33								
	310	109	1 290	2 120	186	1 300	1 900	31	*	24040 CC/W33	* 24040 CCK30/W33								
	340	112	1 600	2 360	204	1 500	1 900	43	*	23140 CC/W33	* 23140 CCK/W33								
	340	140	1 800	2 800	232	1 000	1 400	53,5	*	24140 CC/W33	* 24140 CCK30/W33								
	360	98	1 460	1 930	166	1 600	2 200	43,5	*	22240 CC/W33	* 22240 CCK/W33								
	360	128	1 860	2 700	228	1 200	1 700	58	*	23240 CC/W33	* 23240 CCK/W33								
	420	138	2 320	2 900	224	1 200	1 500	95	*	22340 CC/W33	* 22340 CCK/W33								
	220	300	60	630	1 080	93	2 000	2 200	12,5	*	23944 CC/W33	* 23944 CCK/W33							
340		90	1 220	1 860	163	1 600	2 000	30,5	*	23044 CC/W33	* 23044 CCK/W33								
340		118	1 560	2 600	212	1 200	1 700	40	*	24044 CC/W33	* 24044 CCK30/W33								
370		120	1 800	2 750	232	1 300	1 700	53,5	*	23144 CC/W33	* 23144 CCK/W33								
370		150	2 120	3 350	285	850	1 200	67	*	24144 CC/W33	* 24144 CCK30/W33								
400		108	1 760	2 360	196	1 500	2 000	60,5	*	22244 CC/W33	* 22244 CCK/W33								
400		144	2 360	3 450	285	1 100	1 500	81,5	*	23244 CC/W33	* 23244 CCK/W33								
460		145	2 700	3 450	260	1 000	1 400	120	*	22344 CC/W33	* 22344 CCK/W33								

* SKF Explorer bearing

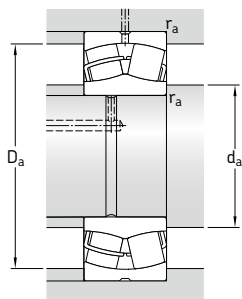

Dimensions					Abutment and fillet dimensions			Calculation factors					
d	d ₂	D ₁	b	K	r _{1,2} min.	d _a min.	D _a max.	r _a max.	e	Y ₁	Y ₂	Y ₀	
mm					mm			-					
180	199	231	6	3	2	189	241	2	0,18	3,8	5,6	3,6	
	204	249	13,9	7,5	2,1	191	269	2	0,24	2,8	4,2	2,8	
	201	243	8,3	4,5	2,1	191	269	2	0,33	2	3	2	
	207	259	13,9	7,5	3	194	286	2,5	0,3	2,3	3,4	2,2	
	203	253	11,1	6	3	194	286	2,5	0,37	1,8	2,7	1,8	
	213	278	16,7	9	4	197	303	3	0,26	2,6	3,9	2,5	
	211	271	13,9	7,5	4	197	303	3	0,35	1,9	2,9	1,8	
	224	317	22,3	12	4	197	363	3	0,35	1,9	2,9	1,8	
	190	209	240	6	3	2	199	251	2	0,16	4,2	6,3	4
		216	261	13,9	7,5	2,1	201	279	2	0,23	2,9	4,4	2,8
210		253	8,3	4,5	2,1	201	279	2	0,31	2,2	3,3	2,2	
220		275	13,9	7,5	3	204	306	2,5	0,31	2,2	3,3	2,2	
215		268	11,1	6	3	204	306	2,5	0,4	1,7	2,5	1,6	
225		294	16,7	9	4	207	323	3	0,26	2,6	3,9	2,5	
222		287	16,7	9	4	207	323	3	0,35	1,9	2,9	1,8	
236		333	22,3	12	5	210	380	4	0,35	1,9	2,9	1,8	
200		222	258	8,3	4,5	2,1	211	269	2	0,19	3,6	5,3	3,6
		228	278	13,9	7,5	2,1	211	299	2	0,24	2,8	4,2	2,8
	223	268	11,1	6	2,1	211	299	2	0,33	2	3	2	
	231	293	16,7	9	3	214	326	2,5	0,31	2,2	3,3	2,2	
	226	284	11,1	6	3	214	326	2,5	0,4	1,7	2,5	1,6	
	238	313	16,7	9	4	217	343	3	0,26	2,6	3,9	2,5	
	235	304	16,7	9	4	217	343	3	0,35	1,9	2,9	1,8	
	249	351	22,3	12	5	220	400	4	0,33	2	3	2	
	220	241	278	8,3	4,5	2,1	231	289	2	0,16	4,2	6,3	4
		250	306	13,9	7,5	3	233	327	2,5	0,24	2,8	4,2	2,8
244		295	11,1	6	3	233	327	2,5	0,33	2	3	2	
255		320	16,7	9	4	237	353	3	0,3	2,3	3,4	2,2	
248		310	11,1	6	4	237	353	3	0,4	1,7	2,5	1,6	
263		346	16,7	9	4	237	383	3	0,27	2,5	3,7	2,5	
259		338	16,7	9	4	237	383	3	0,35	1,9	2,9	1,8	
279		389	22,3	12	5	240	440	4	0,31	2,2	3,3	2,2	

8.1 Spherical roller bearings d 240 – 300 mm

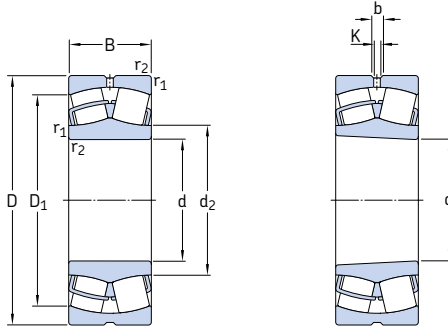

Cylindrical bore

Tapered bore

Principal dimensions	Basic load ratings	static	Fatigue load limit	Speed ratings		Mass	Designations	Designations	Designations	
				dynamic	limit					Reference speed
d	D	B	C	C_0	P_u	r/min	kg	-	-	
mm			kN	kN						
240	320	60	655	1160	98	1 900	2 000	13,5	* 23948 CC/W33	* 23948 CCK/W33
	360	92	1 290	2 080	176	1 500	1 900	33,5	* 23048 CC/W33	* 23048 CCK/W33
	360	118	1 600	2 700	228	1 100	1 600	43	* 24048 CC/W33	* 24048 CCK30/W33
	400	128	2 080	3 200	255	1 200	1 600	66,5	* 23148 CC/W33	* 23148 CCK/W33
	400	160	2 400	3 900	320	750	1 100	83	* 24148 CC/W33	* 24148 CCK30/W33
	440	120	2 200	3 000	245	1 300	1 800	83	* 22248 CC/W33	* 22248 CCK/W33
440	160	2 900	4 300	345	950	1 300	110	* 23248 CC/W33	* 23248 CCK/W33	
500	155	3 100	4 000	290	950	1 300	155	* 22348 CC/W33	* 22348 CCK/W33	
260	360	75	1 000	1 800	156	1 700	1 900	23,5	* 23952 CC/W33	* 23952 CCK/W33
	400	104	1 600	2 550	212	1 300	1 700	48,5	* 23052 CC/W33	* 23052 CCK/W33
	400	140	2 040	3 450	285	1 000	1 400	65,5	* 24052 CC/W33	* 24052 CCK30/W33
	440	144	2 550	3 900	290	1 100	1 400	90,5	* 23152 CC/W33	* 23152 CCK/W33
	440	180	3 000	4 800	380	670	950	110	* 24152 CC/W33	* 24152 CCK30/W33
	480	130	2 650	3 550	285	1 200	1 600	110	* 22252 CC/W33	* 22252 CCK/W33
480	174	3 250	4 750	360	850	1 200	140	* 23252 CC/W33	* 23252 CCK/W33	
540	165	3 550	4 550	325	850	1 100	190	* 22352 CC/W33	* 22352 CCK/W33	
280	380	75	965	1 760	143	1 600	1 700	25	* 23956 CC/W33	* 23956 CCK/W33
	420	106	1 730	2 850	224	1 300	1 600	52,5	* 23056 CC/W33	* 23056 CCK/W33
	420	140	2 160	3 800	285	950	1 400	69,5	* 24056 CC/W33	* 24056 CCK30/W33
	460	146	2 650	4 250	335	1 000	1 300	97	* 23156 CC/W33	* 23156 CCK/W33
	460	180	3 100	5 100	415	630	900	120	* 24156 CC/W33	* 24156 CCK30/W33
	500	130	2 700	3 750	300	1 100	1 500	115	* 22256 CC/W33	* 22256 CCK/W33
500	176	3 250	4 900	365	800	1 100	150	* 23256 CC/W33	* 23256 CCK/W33	
580	175	4 000	5 200	365	800	1 100	235	* 22356 CC/W33	* 22356 CCK/W33	
300	420	90	1 370	2 500	200	1 400	1 600	39,5	* 23960 CC/W33	* 23960 CCK/W33
	460	118	2 120	3 450	265	1 200	1 500	71,5	* 23060 CC/W33	* 23060 CCK/W33
	460	160	2 700	4 750	355	850	1 200	97	* 24060 CC/W33	* 24060 CCK30/W33
	500	160	3 200	5 100	380	950	1 200	125	* 23160 CC/W33	* 23160 CCK/W33
	500	200	3 750	6 300	465	560	800	160	* 24160 CC/W33	* 24160 CCK30/W33
	540	140	3 150	4 250	325	1 000	1 400	135	* 22260 CC/W33	* 22260 CCK/W33
540	192	3 900	5 850	425	750	1 000	190	* 23260 CC/W33	* 23260 CCK/W33	

* SKF Explorer bearing

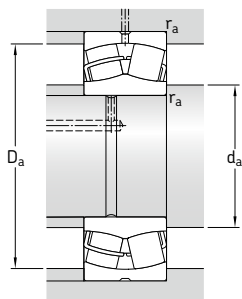

Dimensions					Abutment and fillet dimensions			Calculation factors					
d	d ₂	D ₁	b	K	r _{1,2} min.	d _a min.	D _a max.	r _a max.	e	Y ₁	Y ₂	Y ₀	
mm						mm			-				
240	261	298	8,3	4,5	2,1	251	309	2	0,15	4,5	6,7	4,5	
	271	326	13,9	7,5	3	253	347	2,5	0,23	2,9	4,4	2,8	
	265	316	11,1	6	3	253	347	2,5	0,3	2,3	3,4	2,2	
	277	348	16,7	9	4	257	383	3	0,3	2,3	3,4	2,2	
	271	336	11,1	6	4	257	383	3	0,4	1,7	2,5	1,6	
	290	383	22,3	12	4	257	423	3	0,27	2,5	3,7	2,5	
	286	374	22,3	12	4	257	423	3	0,35	1,9	2,9	1,8	
	303	423	22,3	12	5	260	480	4	0,31	2,2	3,3	2,2	
	260	287	331	8,3	4,5	2,1	271	349	2	0,18	3,8	5,6	3,6
		295	360	16,7	9	4	275	385	3	0,23	2,9	4,4	2,8
289		347	11,1	6	4	275	385	3	0,33	2	3	2	
301		380	16,7	9	4	277	423	3	0,31	2,2	3,3	2,2	
293		368	13,9	7,5	4	277	423	3	0,4	1,7	2,5	1,6	
312		421	22,3	12	5	280	460	4	0,27	2,5	3,7	2,5	
312		408	22,3	12	5	280	460	4	0,35	1,9	2,9	1,8	
328		458	22,3	12	6	286	514	5	0,31	2,2	3,3	2,2	
280		308	352	11,1	6	2,1	291	369	2	0,16	4,2	6,3	4
		315	380	16,7	9	4	295	405	3	0,23	2,9	4,4	2,8
	309	368	11,1	6	4	295	405	3	0,31	2,2	3,3	2,2	
	321	401	16,7	9	5	300	440	4	0,3	2,3	3,4	2,2	
	314	390	13,9	7,5	5	300	440	4	0,4	1,7	2,5	1,6	
	333	441	22,3	12	5	300	480	4	0,26	2,6	3,9	2,5	
	332	429	22,3	12	5	300	480	4	0,35	1,9	2,9	1,8	
	354	492	22,3	12	6	306	554	5	0,3	2,3	3,4	2,2	
	300	333	385	11,1	6	3	313	407	2,5	0,19	3,6	5,3	3,6
		340	414	16,7	9	4	315	445	3	0,23	2,9	4,4	2,8
331		400	13,9	7,5	4	315	445	3	0,33	2	3	2	
345		434	16,7	9	5	320	480	4	0,3	2,3	3,4	2,2	
338		422	13,9	7,5	5	320	480	4	0,4	1,7	2,5	1,6	
354		477	22,3	12	5	311	520	4	0,26	2,6	3,9	2,5	
356		461	22,3	12	5	320	520	4	0,35	1,9	2,9	1,8	

8.1 Spherical roller bearings d 320 – 400 mm

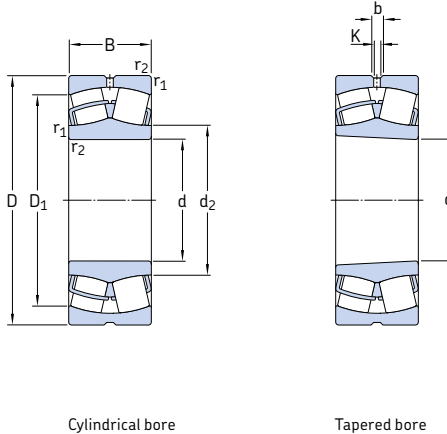

Principal dimensions	Basic load ratings	static	Fatigue load limit	Speed ratings		Mass	Designations	Designations		
				dynamic	Reference speed				Limiting speed	Bearing with cylindrical bore
d	D	B	C	C ₀	P _u	r/min	kg	–		
mm			kN	kN						
320	440	90	1 430	2 700	212	1 400	1 500	42	* 23964 CC/W33	* 23964 CCK/W33
	480	121	2 240	3 800	285	1 100	1 400	78	* 23064 CC/W33	* 23064 CCK/W33
	480	160	2 850	5 100	400	800	1 200	100	* 24064 CC/W33	* 24064 CCK30/W33
	540	176	3 750	6 000	440	850	1 100	165	* 23164 CC/W33	* 23164 CCK/W33
	540	218	4 250	7 100	510	500	700	210	* 24164 CC/W33	* 24164 CCK30/W33
	580	150	3 600	4 900	375	950	1 300	175	* 22264 CC/W33	* 22264 CCK/W33
	580	208	4 400	6 700	480	700	950	240	* 23264 CC/W33	* 23264 CCK/W33
340	460	90	1 460	2 800	216	1 300	1 400	45,5	* 23968 CC/W33	* 23968 CCK/W33
	520	133	2 700	4 550	335	1 000	1 300	105	* 23068 CC/W33	* 23068 CCK/W33
	520	180	3 450	6 200	475	750	1 100	140	* 24068 CC/W33	* 24068 CCK30/W33
	580	190	4 250	6 800	480	800	1 000	210	* 23168 CC/W33	* 23168 CCK/W33
	580	243	5 300	8 650	630	430	630	280	* 24168 ECCJ/W33	* 24168 ECCK30J/W33
	620	224	5 100	7 800	550	560	800	295	* 23268 CA/W33	* 23268 CAK/W33
360	480	90	1 400	2 750	220	1 200	1 300	46	* 23972 CC/W33	* 23972 CCK/W33
	540	134	2 750	4 800	345	950	1 200	110	* 23072 CC/W33	* 23072 CCK/W33
	540	180	3 550	6 550	490	700	1 000	145	* 24072 CC/W33	* 24072 CCK30/W33
	600	192	4 300	6 950	490	750	1 000	220	* 23172 CC/W33	* 23172 CCK/W33
	600	243	5 600	9 300	670	400	600	280	* 24172 ECCJ/W33	* 24172 ECCK30J/W33
	650	170	4 300	6 200	440	630	850	255	* 22272 CA/W33	* 22272 CAK/W33
	650	232	5 400	8 300	570	530	750	335	* 23272 CA/W33	* 23272 CAK/W33
380	520	106	1 960	3 800	285	1 100	1 200	69	* 23976 CC/W33	* 23976 CCK/W33
	560	135	2 900	5 000	360	900	1 200	115	* 23076 CC/W33	* 23076 CCK/W33
	560	180	3 600	6 800	480	670	950	150	* 24076 CC/W33	* 24076 CCK30/W33
	620	194	4 400	7 100	500	560	1 000	230	* 23176 CA/W33	* 23176 CAK/W33
	620	243	5 700	9 800	710	360	530	300	* 24176 ECA/W33	* 24176 ECAK30/W33
	680	240	5 850	9 150	620	500	750	375	* 23276 CA/W33	* 23276 CAK/W33
400	540	106	2 000	3 900	290	1 100	1 200	71	* 23980 CC/W33	* 23980 CCK/W33
	600	148	3 400	5 850	415	850	1 100	150	* 23080 CC/W33	* 23080 CCK/W33
	600	200	4 300	8 000	560	630	900	205	* 24080 ECCJ/W33	* 24080 ECCK30J/W33
	650	200	4 650	7 650	530	530	950	265	* 23180 CA/W33	* 23180 CAK/W33
	650	250	6 200	10 600	735	340	500	340	* 24180 ECA/W33	* 24180 ECAK30/W33
	720	256	6 550	10 400	680	480	670	450	* 23280 CA/W33	* 23280 CAK/W33
	820	243	7 500	10 400	670	430	750	650	* 22380 CA/W33	* 22380 CAK/W33

* SKF Explorer bearing

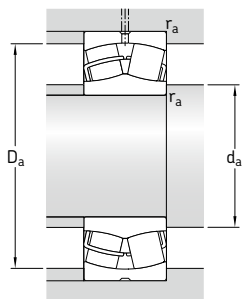

Dimensions						Abutment and fillet dimensions			Calculation factors			
d	d ₂	D ₁	b	K	r _{1,2} min.	d _a min.	D _a max.	r _a max.	e	Y ₁	Y ₂	Y ₀
mm						mm			-			
320	354	406	11,1	6	3	333	427	2,5	0,17	4	5,9	4
	360	434	16,7	9	4	335	465	3	0,23	2,9	4,4	2,8
	354	423	13,9	7,5	4	335	465	3	0,31	2,2	3,3	2,2
	370	465	22,3	12	5	340	520	4	0,31	2,2	3,3	2,2
	364	455	16,7	9	5	340	520	4	0,4	1,7	2,5	1,6
	379	513	22,3	12	5	340	560	4	0,26	2,6	3,9	2,5
382	493	22,3	12	5	340	560	4	0,35	1,9	2,9	1,8	
340	373	426	11,1	6	3	353	447	2,5	0,17	4	5,9	4
	385	468	22,3	12	5	358	502	4	0,24	2,8	4,2	2,8
	377	453	16,7	9	5	358	502	4	0,33	2	3	2
	394	498	22,3	12	5	360	560	4	0,31	2,2	3,3	2,2
	383	491	16,7	9	5	360	560	4	0,4	1,7	2,5	1,6
	427	528	22,3	12	6	366	594	5	0,35	1,9	2,9	1,8
360	394	447	11,1	6	3	373	467	2,5	0,15	4,5	6,7	4,5
	404	483	22,3	12	5	378	522	4	0,23	2,9	4,4	2,8
	397	474	16,7	9	5	378	522	4	0,31	2,2	3,3	2,2
	418	524	22,3	12	5	380	580	4	0,3	2,3	3,4	2,2
	404	511	16,7	9	5	380	580	4	0,4	1,7	2,5	1,6
	454	568	22,3	12	6	386	624	5	0,26	2,6	3,9	2,5
449	552	22,3	12	6	386	624	5	0,35	1,9	2,9	1,8	
380	419	481	13,9	7,5	4	395	505	3	0,17	4	5,9	4
	426	509	22,3	12	5	398	542	4	0,22	3	4,6	2,8
	419	497	16,7	9	5	398	542	4	0,3	2,3	3,4	2,2
	454	541	22,3	12	5	400	600	4	0,3	2,3	3,4	2,2
	444	532	16,7	9	5	400	600	4	0,37	1,8	2,7	1,8
	473	581	22,3	12	6	406	654	5	0,35	1,9	2,9	1,8
400	439	500	13,9	7,5	4	415	525	3	0,16	4,2	6,3	4
	450	543	22,3	12	5	418	582	4	0,23	2,9	4,4	2,8
	442	527	22,3	12	5	418	582	4	0,3	2,3	3,4	2,2
	475	566	22,3	12	6	426	624	5	0,28	2,4	3,6	2,5
	467	559	22,3	12	6	426	624	5	0,37	1,8	2,7	1,8
	500	615	22,3	12	6	426	694	5	0,35	1,9	2,9	1,8
534	697	22,3	12	7,5	432	788	6	0,3	2,3	3,4	2,2	

8.1 Spherical roller bearings d 420 – 500 mm

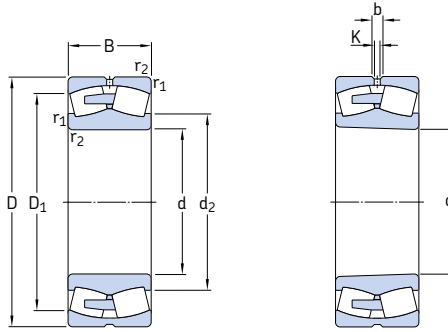

Cylindrical bore

Tapered bore

Principal dimensions	Basic load ratings	static	Fatigue load limit	Speed ratings		Mass	Designations	Designations		
				dynamic	Reference speed				Limiting speed	Bearing with cylindrical bore
d	D	B	C	C ₀	P _u	r/min	kg	–		
mm			kN	kN						
420	560	106	2 040	4 150	300	1 000	1 100	74,5	* 23984 CC/W33	* 23984 CCK/W33
	620	150	3 400	6 000	415	600	1 100	155	* 23084 CA/W33	* 23084 CAK/W33
	620	200	4 400	8 300	585	530	900	210	* 24084 ECA/W33	* 24084 ECAK30/W33
	700	224	5 600	9 300	620	480	900	350	* 23184 CJ/W33	* 23184 CKJ/W33
	700	280	7 350	12 600	850	320	480	445	* 24184 ECA/W33	* 24184 ECAK30/W33
	760	272	7 350	11 600	765	450	630	535	* 23284 CA/W33	* 23284 CAK/W33
440	600	118	2 450	4 900	345	950	1 000	99,5	* 23988 CC/W33	* 23988 CCK/W33
	650	157	3 650	6 550	450	560	1 000	180	* 23088 CA/W33	* 23088 CAK/W33
	650	212	4 800	9 150	630	500	850	245	* 24088 ECA/W33	* 24088 ECAK30/W33
	720	226	6 000	10 000	670	450	850	360	* 23188 CA/W33	* 23188 CAK/W33
	720	280	7 500	13 200	900	300	450	460	* 24188 ECA/W33	* 24188 ECAK30/W33
	790	280	7 800	12 500	800	430	600	590	* 23288 CA/W33	* 23288 CAK/W33
460	580	118	2 080	4 900	345	630	1 100	75,5	* 24892 CAMA/W20	* 24892 CAK30MA/W20
	620	118	2 500	5 000	355	600	1 000	105	* 23992 CA/W33	* 23992 CAK/W33
	680	163	3 900	6 950	465	560	950	205	* 23092 CA/W33	* 23092 CAK/W33
	680	218	5 200	10 000	670	480	800	275	* 24092 ECA/W33	* 24092 ECAK30/W33
	760	240	6 400	10 800	680	430	800	440	* 23192 CA/W33	* 23192 CAK/W33
	760	300	8 300	14 600	1 000	280	430	560	* 24192 ECA/W33	* 24192 ECAK30/W33
480	830	296	8 500	13 700	880	400	560	695	* 23292 CA/W33	* 23292 CAK/W33
	650	128	2 900	5 700	405	560	1 000	125	* 23996 CA/W33	* 23996 CAK/W33
	700	165	3 900	6 800	450	530	950	215	* 23096 CA/W33	* 23096 CAK/W33
	700	218	5 300	10 400	695	450	750	285	* 24096 ECA/W33	* 24096 ECAK30/W33
	790	248	6 950	12 000	780	400	750	485	* 23196 CA/W33	* 23196 CAK/W33
	790	308	9 000	15 600	1 040	260	400	605	* 24196 ECA/W33	* 24196 ECAK30/W33
500	870	310	9 300	15 000	950	380	530	800	* 23296 CA/W33	* 23296 CAK/W33
	670	128	2 900	6 000	415	530	950	130	* 239/500 CA/W33	* 239/500 CAK/W33
	720	167	4 150	7 800	510	500	900	225	* 230/500 CA/W33	* 230/500 CAK/W33
	720	218	5 500	11 000	735	430	700	295	* 240/500 ECA/W33	* 240/500 ECAK30/W33
	830	264	7 650	12 900	830	380	700	580	* 231/500 CA/W33	* 231/500 CAK/W33
	830	325	9 800	17 000	1 120	260	380	700	* 241/500 ECA/W33	* 241/500 ECAK30/W33
920	336	10 600	17 300	1 060	360	500	985	* 232/500 CA/W33	* 232/500 CAK/W33	

* SKF Explorer bearing

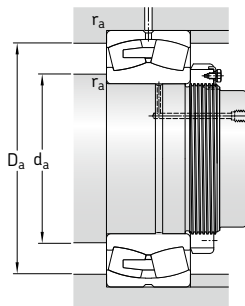

Dimensions						Abutment and fillet dimensions			Calculation factors			
d	d ₂	D ₁	b	K	r _{1,2} min.	d _a min.	D _a max.	r _a max.	e	Y ₁	Y ₂	Y ₀
mm						mm			-			
420	459	520	16,7	9	4	435	545	3	0,16	4,2	6,3	4
	487	563	22,3	12	5	438	602	4	0,22	3	4,6	2,8
	477	547	22,3	12	5	438	602	4	0,3	2,3	3,4	2,2
	483	607	22,3	12	6	446	674	5	0,3	2,3	3,4	2,2
	494	597	22,3	12	6	446	674	5	0,4	1,7	2,5	1,6
	526	649	22,3	12	7,5	452	728	6	0,35	1,9	2,9	1,8
440	484	553	16,7	9	4	455	585	3	0,16	4,2	6,3	4
	511	590	22,3	12	6	463	627	5	0,22	3	4,6	2,8
	499	572	22,3	12	6	463	627	5	0,3	2,3	3,4	2,2
	529	632	22,3	12	6	466	694	5	0,3	2,3	3,4	2,2
	516	618	22,3	12	6	466	694	5	0,37	1,8	2,7	1,8
	549	676	22,3	12	7,5	472	758	6	0,35	1,9	2,9	1,8
460	505	541	-	7,5	3	473	567	2,5	0,17	4	5,9	4
	516	574	16,7	9	4	475	605	3	0,16	4,2	6,3	4
	533	617	22,3	12	6	483	657	5	0,22	3	4,6	2,8
	524	601	22,3	12	6	483	657	5	0,28	2,4	3,6	2,5
	555	666	22,3	12	7,5	492	728	6	0,3	2,3	3,4	2,2
	543	649	22,3	12	7,5	492	728	6	0,37	1,8	2,7	1,8
480	574	706	22,3	12	7,5	492	798	6	0,35	1,9	2,9	1,8
	537	602	16,7	9	5	498	632	4	0,18	3,8	5,6	3,6
	549	633	22,3	12	6	503	677	5	0,21	3,2	4,8	3,2
	542	619	22,3	12	6	503	677	5	0,28	2,4	3,6	2,5
	579	692	22,3	12	7,5	512	758	6	0,3	2,3	3,4	2,2
	564	678	22,3	12	7,5	512	758	6	0,37	1,8	2,7	1,8
500	602	741	22,3	12	7,5	512	838	6	0,35	1,9	2,9	1,8
	561	622	22,3	12	5	518	652	4	0,17	4	5,9	4
	573	658	22,3	12	6	523	697	5	0,21	3,2	4,8	3,2
	566	644	22,3	12	6	523	697	5	0,26	2,6	3,9	2,5
	605	726	22,3	12	7,5	532	798	6	0,3	2,3	3,4	2,2
	588	713	22,3	12	7,5	532	798	6	0,37	1,8	2,7	1,8
633	779	22,3	12	7,5	532	888	6	0,35	1,9	2,9	1,8	

8.1 Spherical roller bearings

d 530 – 670 mm

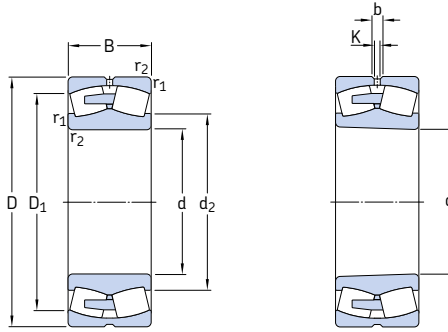

Cylindrical bore

Tapered bore

Principal dimensions	Basic load ratings	Fatigue load limit	Speed ratings		Mass	Designations	Designations				
			dynamic	static				Reference speed	Limiting speed	Bearing with cylindrical bore	tapered bore
d	D	B	C	C ₀	P _u						
mm			kN	kN	r/min	kg	–				
530	650	118	2 120	5 300	380	530	950	86	* 248/530 CAMA/W20	* 248/530 CAK30MA/W20	
	710	136	3 200	6 700	480	500	900	155	* 239/530 CA/W33	* 239/530 CAK/W33	
	780	185	5 100	9 300	630	450	800	310	* 230/530 CA/W33	* 230/530 CAK/W33	
	780	250	6 700	13 200	830	400	670	410	* 240/530 ECA/W33	* 240/530 ECAK30/W33	
	870	272	8 150	14 000	915	360	670	645	* 231/530 CA/W33	* 231/530 CAK/W33	
	870	335	10 600	19 000	1 220	240	360	830	* 241/530 ECA/W33	* 241/530 ECAK30/W33	
	980	355	12 700	20 400	1 220	320	480	1 200	* 232/530 CA/W33	* 232/530 CAK/W33	
	560	750	140	3 450	7 200	510	450	850	175	* 239/560 CA/W33	* 239/560 CAK/W33
		820	195	5 600	10 200	680	430	750	355	* 230/560 CA/W33	* 230/560 CAK/W33
		820	258	7 350	14 600	960	380	630	465	* 240/560 ECA/W33	* 240/560 ECAK30/W33
920		280	9 150	16 000	980	340	630	740	* 231/560 CA/W33	* 231/560 CAK/W33	
920		355	12 000	21 600	1 340	220	320	985	* 241/560 ECJ/W33	* 241/560 ECK30J/W33	
1 030		365	13 400	22 000	1 320	280	430	1 350	* 232/560 CA/W33	* 232/560 CAK/W33	
600	800	150	3 900	8 300	585	430	750	220	* 239/600 CA/W33	* 239/600 CAK/W33	
	870	200	6 000	11 400	750	400	700	405	* 230/600 CA/W33	* 230/600 CAK/W33	
	870	272	8 150	17 000	1 100	340	560	520	* 240/600 ECA/W33	* 240/600 ECAK30/W33	
	980	300	10 200	18 000	1 100	320	560	895	* 231/600 CA/W33	* 231/600 CAK/W33	
	980	375	13 200	23 600	1 460	200	300	1 200	* 241/600 ECA/W33	* 241/600 ECAK30/W33	
	1 090	388	15 000	25 500	1 460	260	400	1 600	* 232/600 CA/W33	* 232/600 CAK/W33	
630	780	112	2 500	6 100	415	430	750	120	* 238/630 CAMA/W20	* 238/630 CAKMA/W20	
	850	165	4 650	9 800	640	400	700	280	* 239/630 CA/W33	* 239/630 CAK/W33	
	920	212	6 700	12 500	800	380	670	485	* 230/630 CA/W33	* 230/630 CAK/W33	
	920	290	8 800	18 000	1 140	320	530	645	* 240/630 ECJ/W33	* 240/630 ECK30J/W33	
	1 030	315	12 000	20 800	1 220	260	530	1 050	* 231/630 CA/W33	* 231/630 CAK/W33	
	1 030	400	14 600	27 000	1 630	190	280	1 400	* 241/630 ECA/W33	* 241/630 ECAK30/W33	
670	820	112	2 600	6 400	430	400	700	130	* 238/670 CAMA/W20	* 238/670 CAKMA/W20	
	900	170	5 000	10 800	695	360	670	315	* 239/670 CA/W33	* 239/670 CAK/W33	
	980	230	7 650	14 600	915	340	600	600	* 230/670 CA/W33	* 230/670 CAK/W33	
	980	308	10 000	20 400	1 320	300	500	790	* 240/670 ECA/W33	* 240/670 ECAK30/W33	
	1 090	336	12 500	22 400	1 320	240	500	1 250	* 231/670 CA/W33	* 231/670 CAK/W33	
	1 220	412	16 000	29 000	1 760	180	260	1 600	* 241/670 ECA/W33	* 241/670 ECAK30/W33	
	1 220	438	18 000	30 500	1 700	220	360	2 270	* 232/670 CA/W33	* 232/670 CAK/W33	

* SKF Explorer bearing

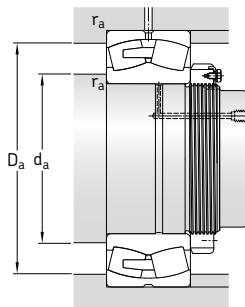

Dimensions					Abutment and fillet dimensions			Calculation factors				
d	d ₂	D ₁	b	K	r _{1,2} min.	d _a min.	D _a max.	r _a max.	e	Y ₁	Y ₂	Y ₀
mm					mm			-				
530	573	612	-	7,5	3	543	637	2,5	0,15	4,5	6,7	4,5
	594	661	22,3	12	5	548	692	4	0,17	4	5,9	4
	613	710	22,3	12	6	553	757	5	0,22	3	4,6	2,8
	601	687	22,3	12	6	553	757	5	0,28	2,4	3,6	2,5
	638	763	22,3	12	7,5	562	838	6	0,3	2,3	3,4	2,2
	623	748	22,3	12	7,5	562	838	6	0,37	1,8	2,7	1,8
	670	836	22,3	12	9,5	570	940	8	0,35	1,9	2,9	1,8
	627	697	22,3	12	5	578	732	4	0,16	4,2	6,3	4
	646	746	22,3	12	6	583	797	5	0,22	3	4,6	2,8
	637	728	22,3	12	6	583	797	5	0,28	2,4	3,6	2,5
560	675	809	22,3	12	7,5	592	888	6	0,3	2,3	3,4	2,2
	634	796	22,3	12	7,5	592	888	6	0,35	1,9	2,9	1,8
	706	878	22,3	12	9,5	600	990	8	0,35	1,9	2,9	1,8
	671	744	22,3	12	5	618	782	4	0,17	4	5,9	4
	685	789	22,3	12	6	623	847	5	0,22	3	4,6	2,8
600	675	774	22,3	12	6	623	847	5	0,3	2,3	3,4	2,2
	722	863	22,3	12	7,5	632	948	6	0,3	2,3	3,4	2,2
	702	845	22,3	12	7,5	632	948	6	0,37	1,8	2,7	1,8
	754	929	22,3	12	9,5	640	1050	8	0,35	1,9	2,9	1,8
	682	738	-	9	4	645	765	3	0,12	5,6	8,4	5,6
	708	787	22,3	12	6	653	827	5	0,17	4	5,9	4
630	727	839	22,3	12	7,5	658	892	6	0,21	3,2	4,8	3,2
	697	823	22,3	12	7,5	658	892	6	0,28	2,4	3,6	2,5
	755	918	22,3	12	7,5	662	998	6	0,3	2,3	3,4	2,2
	738	885	22,3	12	7,5	662	998	6	0,37	1,8	2,7	1,8
	724	778	-	9	4	685	805	3	0,11	6,1	9,1	6,3
	752	835	22,3	12	6	693	877	5	0,17	4	5,9	4
	772	892	22,3	12	7,5	698	952	6	0,21	3,2	4,8	3,2
670	758	866	22,3	12	7,5	698	952	6	0,28	2,4	3,6	2,5
	804	959	22,3	12	7,5	702	1058	6	0,3	2,3	3,4	2,2
	782	942	22,3	12	7,5	702	1058	6	0,37	1,8	2,7	1,8
	832	1028	22,3	12	12	718	1172	10	0,35	1,9	2,9	1,8

8.1 Spherical roller bearings d 710 – 850 mm

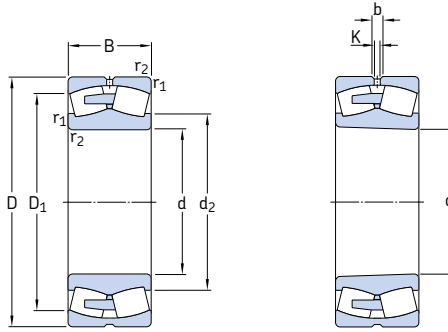

Cylindrical bore

Tapered bore

Principal dimensions	Basic load ratings	Fatigue load limit	Speed ratings		Mass	Designations	Designations												
			dynamic	static				Reference speed	Limiting speed	Bearing with cylindrical bore	tapered bore								
d	D	B	C	C ₀	P _u														
mm			kN	kN	r/min	kg													
710	870	118	3 000	7 500	500	360	670	153	*	238/710 CAMA/W20	* 238/710 CAKMA/W20								
	950	180	5 600	12 000	765	340	600	365	*	239/710 CA/W33	* 239/710 CAK/W33								
	950	243	6 800	15 600	930	300	500	495	*	249/710 CA/W33	* 249/710 CAK30/W33								
	1 030	236	8 300	16 300	1 000	300	560	670	*	230/710 CA/W33	* 230/710 CAK/W33								
	1 030	315	10 600	22 800	1 370	260	450	895	*	240/710 ECA/W33	* 240/710 ECAK30/W33								
	1 150	345	14 000	26 000	1 530	240	450	1 450	*	231/710 CA/W33	* 231/710 CAK/W33								
	1 150	438	17 300	32 500	1 900	160	240	1 900	*	241/710 ECA/W33	* 241/710 ECAK30/W33								
1 280	450	20 400	34 500	2 000	200	320	2 610	*	232/710 CA/W33	* 232/710 CAK/W33									
750	920	128	3 350	8 500	550	340	600	185	*	238/750 CAMA/W20	* 238/750 CAKMA/W20								
	1 000	185	6 000	13 200	815	320	560	420	*	239/750 CA/W33	* 239/750 CAK/W33								
	1 000	250	7 650	18 000	1 100	280	480	560	*	249/750 CA/W33	* 249/750 CAK30/W33								
	1 090	250	9 650	18 600	1 100	280	530	795	*	230/750 CA/W33	* 230/750 CAK/W33								
	1 090	335	11 800	25 000	1 460	240	430	1 070	*	240/750 ECA/W33	* 240/750 ECAK30/W33								
	1 220	365	15 600	29 000	1 700	220	430	1 700	*	231/750 CA/W33	* 231/750 CAK/W33								
	1 220	475	20 000	37 500	2 160	150	220	2 100	*	241/750 ECA/W33	* 241/750 ECAK30/W33								
1 360	475	21 600	36 500	2 000	190	300	3 050	*	232/750 CAF/W33	* 232/750 CAF/W33									
800	980	180	4 750	12 900	830	320	560	300	*	248/800 CAMA/W20	* 248/800 CAK30MA/W20								
	1 060	195	6 400	14 300	880	280	530	470	*	239/800 CA/W33	* 239/800 CAK/W33								
	1 060	258	8 000	19 300	1 060	240	430	640	*	249/800 CA/W33	* 249/800 CAK30/W33								
	1 150	258	10 000	20 000	1 160	260	480	895	*	230/800 CA/W33	* 230/800 CAK/W33								
	1 150	345	12 900	28 500	1 730	220	400	1 200	*	240/800 ECA/W33	* 240/800 ECAK30/W33								
	1 280	375	17 300	31 500	1 800	200	400	1 920	*	231/800 CA/W33	* 231/800 CAK/W33								
	1 280	475	20 800	40 500	2 320	140	200	2 300	*	241/800 ECA/W33	* 241/800 ECAK30/W33								
1 420	488	24 000	43 000	2 360	180	280	3 280	*	232/800 CAF/W33	* 232/800 CAF/W33									
850	1 030	136	3 800	10 000	630	260	530	240	*	238/850 CAMA/W20	* 238/850 CAKMA/W20								
	1 120	200	6 950	15 600	930	260	480	560	*	239/850 CA/W33	* 239/850 CAK/W33								
	1 120	272	9 300	22 800	1 370	220	400	740	*	249/850 CA/W33	* 249/850 CAK30/W33								
	1 220	272	10 800	21 600	1 250	240	450	1 050	*	230/850 CA/W33	* 230/850 CAK/W33								
	1 220	365	14 600	31 500	1 900	200	360	1 410	*	240/850 ECA/W33	* 240/850 ECAK30/W33								
	1 360	400	18 300	34 500	1 900	180	360	2 200	*	231/850 CA/W33	* 231/850 CAK/W33								
	1 360	500	23 200	45 000	2 500	130	190	2 770	*	241/850 ECAF/W33	* 241/850 ECAK30F/W33								

* SKF Explorer bearing

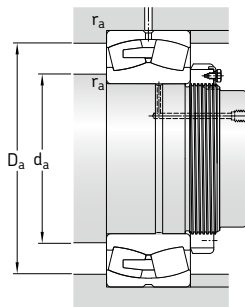

Dimensions					Abutment and fillet dimensions			Calculation factors					
d	d ₂	D ₁	b	K	r _{1,2}	d _a	D _a	r _a	e	Y ₁	Y ₂	Y ₀	
					min.	max.	max.						
mm					mm			-					
710	766	826	-	12	4	725	855	3	0,11	6,1	9,1	6,3	
	794	882	22,3	12	6	733	927	5	0,17	4	5,9	4	
	792	868	22,3	12	6	733	927	5	0,22	3	4,6	2,8	
	816	941	22,3	12	7,5	738	1002	6	0,21	3,2	4,8	3,2	
	809	918	22,3	12	7,5	738	1002	6	0,27	2,5	3,7	2,5	
	851	1017	22,3	12	9,5	750	1110	8	0,28	2,4	3,6	2,5	
	826	989	22,3	12	9,5	750	1110	8	0,37	1,8	2,7	1,8	
	875	1097	22,3	12	12	758	1232	10	0,35	1,9	2,9	1,8	
	750	812	873	-	12	5	768	902	4	0,11	6,1	9,1	6,3
		838	930	22,3	12	6	773	977	5	0,16	4,2	6,3	4
830		916	22,3	12	6	773	977	5	0,22	3	4,6	2,8	
859		998	22,3	12	7,5	778	1062	6	0,21	3,2	4,8	3,2	
855		970	22,3	12	7,5	778	1062	6	0,28	2,4	3,6	2,5	
900		1080	22,3	12	9,5	790	1180	8	0,28	2,4	3,6	2,5	
875		1050	22,3	12	9,5	790	1180	8	0,37	1,8	2,7	1,8	
938		1163	22,3	12	15	808	1302	12	0,35	1,9	2,9	1,8	
800		865	921	-	12	5	818	962	4	0,15	4,5	6,7	4,5
		891	986	22,3	12	6	823	1037	5	0,16	4,2	6,3	4
	887	973	22,3	12	6	823	1037	5	0,21	3,2	4,8	3,2	
	917	1053	22,3	12	7,5	828	1122	6	0,2	3,4	5	3,2	
	910	1028	22,3	12	7,5	828	1122	6	0,27	2,5	3,7	2,5	
	949	1141	22,3	12	9,5	840	1240	8	0,28	2,4	3,6	2,5	
	930	1111	22,3	12	9,5	840	1240	8	0,35	1,9	2,9	1,8	
	995	1238	22,3	12	15	858	1362	12	0,33	2	3	2	
	850	912	981	-	12	5	868	1012	4	0,11	6,1	9,1	6,3
		946	1046	22,3	12	6	873	1097	5	0,16	4,2	6,3	4
940		1029	22,3	12	6	873	1097	5	0,22	3	4,6	2,8	
972		1117	22,3	12	7,5	878	1192	6	0,2	3,4	5	3,2	
957		1088	22,3	12	7,5	878	1192	6	0,27	2,5	3,7	2,5	
1013		1205	22,3	12	12	898	1312	10	0,28	2,4	3,6	2,5	
988		1182	22,3	12	12	898	1312	10	0,35	1,9	2,9	1,8	

8.1 Spherical roller bearings d 900 – 1 250 mm

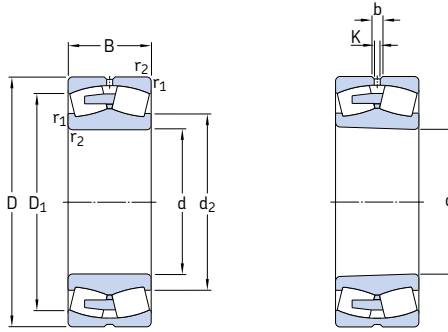

Cylindrical bore

Tapered bore

Principal dimensions	Basic load ratings	Fatigue load limit	Speed ratings		Mass	Designations	Designations											
			dynamic	static				Reference speed	Limiting speed	Bearing with cylindrical bore	tapered bore							
d	D	B	C	C ₀	P _u													
mm	mm	mm	kN	kN	kN	r/min	r/min	kg										
900	1 090	190	5 400	15 300	950	240	480	370	*	248/900 CAMA/W20	* 248/900 CAK30MA/W20							
	1 180	206	7 500	17 000	1 020	240	450	605	*	239/900 CA/W33	* 239/900 CAK/W33							
	1 280	280	11 600	23 200	1 320	220	400	1 200	*	230/900 CA/W33	* 230/900 CAK/W33							
	1 280	375	15 600	34 500	2 040	190	340	1 570	*	240/900 ECA/W33	* 240/900 ECAK30/W33							
	1 420	515	24 500	49 000	2 700	120	180	3 350	*	241/900 ECAF/W33	* 241/900 ECAK30F/W33							
950	1 250	224	8 300	19 600	1 120	220	430	755	*	239/950 CA/W33	* 239/950 CAK/W33							
	1 250	300	10 600	26 000	1 500	180	340	1 020	*	249/950 CA/W33	* 249/950 CAK30/W33							
	1 360	300	13 700	28 500	1 600	200	380	1 450	*	230/950 CA/W33	* 230/950 CAK/W33							
	1 360	412	17 000	39 000	2 240	170	300	1 990	*	240/950 CAF/W33	* 240/950 CAK30F/W33							
	1 500	545	27 000	55 000	3 000	110	160	3 540	*	241/950 ECAF/W33	* 241/950 ECAK30F/W33							
1 000	1 220	165	5 400	14 300	850	220	400	410	*	238/1000 CAMA/W20	* 238/1000 CAKMA/W20							
	1 320	315	11 800	29 000	1 460	170	320	1 200	*	249/1000 CA/W33	* 249/1000 CAK30/W33							
	1 420	308	14 600	30 500	1 700	180	360	1 600	*	230/1000 CAF/W33	* 230/1000 CAKF/W33							
	1 420	412	17 600	40 500	2 240	160	280	2 140	*	240/1000 CAF/W33	* 240/1000 CAK30F/W33							
	1 580	462	24 500	48 000	2 550	140	280	3 500	*	231/1000 CAF/W33	* 231/1000 CAKF/W33							
	1 580	580	30 500	62 000	3 350	100	150	4 300	*	241/1000 ECAF/W33	* 241/1000 ECAK30F/W33							
1 060	1 280	165	5 500	15 000	865	200	380	435	*	238/1060 CAMA/W20	* 238/1060 CAKMA/W20							
	1 280	218	6 950	20 000	1 200	200	380	570	*	248/1060 CAMA/W20	* 248/1060 CAK30MA/W20							
	1 400	250	11 000	26 000	1 430	180	360	1 100	*	239/1060 CAF/W33	* 239/1060 CAKF/W33							
	1 400	335	13 200	32 500	1 800	160	280	1 400	*	249/1060 CAF/W33	* 249/1060 CAK30F/W33							
	1 500	325	16 000	34 000	1 830	170	320	1 840	*	230/1060 CAF/W33	* 230/1060 CAKF/W33							
	1 500	438	20 000	45 500	2 450	150	260	2 520	*	240/1060 CAF/W33	* 240/1060 CAK30F/W33							
1 120	1 360	243	8 300	24 000	1 400	180	340	735	*	248/1120 CAFA/W20	* 248/1120 CAK30FA/W20							
	1 460	335	13 700	34 500	1 830	140	260	1 500	*	249/1120 CAF/W33	* 249/1120 CAK30F/W33							
	1 580	462	21 200	50 000	2 700	130	240	2 930	*	240/1120 CAF/W33	* 240/1120 CAK30F/W33							
1 180	1 420	180	6 700	18 600	1 080	170	320	575	*	238/1180 CAFA/W20	* 238/1180 CAKFA/W20							
	1 420	243	8 800	27 000	1 560	170	320	770	*	248/1180 CAFA/W20	* 248/1180 CAK30FA/W20							
	1 540	272	12 700	31 000	1 660	150	300	1 400	*	239/1180 CAF/W33	* 239/1180 CAKF/W33							
	1 540	355	15 600	40 500	2 160	130	240	1 800	*	249/1180 CAF/W33	* 249/1180 CAK30F/W33							
	1 660	475	24 500	58 500	3 050	130	220	3 320	*	240/1180 CAF/W33	* 240/1180 CAK30F/W33							
1 250	1 750	375	20 400	45 000	2 320	130	240	2 840	*	230/1250 CAF/W33	* 230/1250 CAKF/W33							

* SKF Explorer bearing

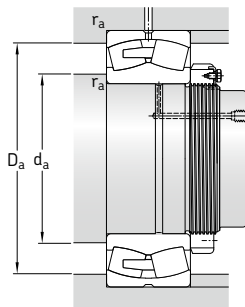

Dimensions						Abutment and fillet dimensions			Calculation factors			
d	d ₂	D ₁	b	K	r _{1,2} min.	d _a min.	D _a max.	r _a max.	e	Y ₁	Y ₂	Y ₀
mm						mm			-			
900	969	1029	-	12	5	918	1072	4	0,14	4,8	7,2	4,5
	996	1101	22,3	12	6	923	1157	5	0,15	4,5	6,7	4,5
	1025	1176	22,3	12	7,5	928	1252	6	0,2	3,4	5	3,2
	1015	1149	22,3	12	7,5	928	1252	6	0,26	2,6	3,9	2,5
	1043	1235	22,3	12	12	948	1372	10	0,35	1,9	2,9	1,8
950	1056	1164	22,3	12	7,5	978	1222	6	0,15	4,5	6,7	4,5
	1051	1150	22,3	12	7,5	978	1222	6	0,21	3,2	4,8	3,2
	1086	1246	22,3	12	7,5	978	1332	6	0,2	3,4	5	3,2
	1077	1214	22,3	12	7,5	978	1332	6	0,27	2,5	3,7	2,5
	1102	1305	22,3	12	12	998	1452	10	0,35	1,9	2,9	1,8
1000	1079	1161	-	12	6	1023	1197	5	0,12	5,6	8,4	5,6
	1109	1212	22,3	12	7,5	1028	1292	6	0,21	3,2	4,8	3,2
	1139	1305	22,3	12	7,5	1028	1392	6	0,19	3,6	5,3	3,6
	1136	1278	22,3	12	7,5	1028	1392	6	0,26	2,6	3,9	2,5
	1185	1403	22,3	12	12	1048	1532	10	0,28	2,4	3,6	2,5
	1159	1373	22,3	12	12	1048	1532	10	0,35	1,9	2,9	1,8
	1160	1246	22,3	12	7,5	1048	1532	10	0,28	2,4	3,6	2,5
1060	1137	1219	-	12	6	1083	1257	5	0,11	6,1	9,1	6,3
	1139	1210	-	12	6	1083	1257	5	0,14	4,8	7,2	4,5
	1171	1305	22,3	12	7,5	1088	1372	6	0,16	4,2	6,3	4
	1168	1286	22,3	12	7,5	1088	1372	6	0,21	3,2	4,8	3,2
	1205	1378	22,3	12	9,5	1094	1466	8	0,19	3,6	5,3	3,6
	1199	1349	22,3	12	9,5	1094	1466	8	0,26	2,6	3,9	2,5
	1200	1378	22,3	12	9,5	1094	1466	8	0,26	2,6	3,9	2,5
1120	1207	1282	-	12	6	1143	1337	5	0,15	4,5	6,7	4,5
	1231	1350	22,3	12	7,5	1148	1432	6	0,2	3,4	5	3,2
	1268	1423	22,3	12	9,5	1154	1546	8	0,26	2,6	3,9	2,5
1180	1264	1355	-	12	6	1203	1397	5	0,11	6,1	9,1	6,3
	1268	1344	-	12	6	1203	1397	5	0,14	4,8	7,2	4,5
	1305	1439	22,3	12	7,5	1208	1512	6	0,16	4,2	6,3	4
	1297	1422	22,3	12	7,5	1208	1512	6	0,2	3,4	5	3,2
	1325	1507	22,3	12	9,5	1200	1626	8	0,26	2,6	3,9	2,5
	1325	1507	22,3	12	9,5	1200	1626	8	0,26	2,6	3,9	2,5
1250	1415	1611	22,3	12	9,5	1284	1716	8	0,19	3,6	5,3	3,6

8.1 Spherical roller bearings

d 1 320 – 1 800 mm

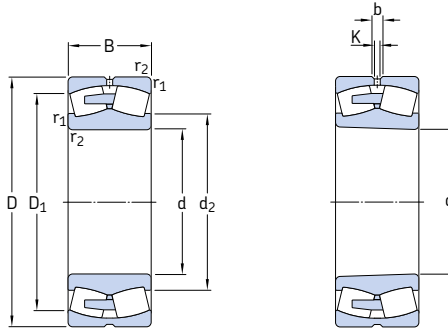

Cylindrical bore

Tapered bore

Principal dimensions		Basic load ratings		Fatigue load limit	Speed ratings		Mass	Designations		
d	D	B	dynamic C	static C ₀	P _u	Refer- ence speed	Limit- ing speed	Bearing with cylindrical bore		
								tapered bore		
mm			kN		kN	r/min	kg	-		
1 320	1 600	280	11 200	33 500	1 860	140	260	1 160	* 248/1320 CAFA/W20	* 248/1320 CAK30FA/W20
	1 720	400	18 600	49 000	2 500	110	200	2 500	* 249/1320 CAF/W33	* 249/1320 CAK30F/W33
1 500	1 820	315	14 600	45 000	2 400	110	220	1 710	* 248/1500 CAFA/W20	* 248/1500 CAK30FA/W20
1 800	2 180	375	20 000	63 000	3 050	75	140	2 900	* 248/1800 CAFA/W20	* 248/1800 CAK30FA/W20

* SKF Explorer bearing

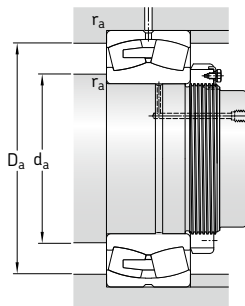

Dimensions						Abutment and fillet dimensions			Calculation factors			
d	d ₂	D ₁	b	K	r _{1,2} min.	d _a min.	D _a max.	r _a max.	e	Y ₁	Y ₂	Y ₀
mm						mm			-			
1320	1422	1511	-	12	6	1343	1577	5	0,15	4,5	6,7	4,5
	1449	1589	22,3	12	7,5	1348	1692	6	0,21	3,2	4,8	3,2
1500	1612	1719	-	12	7,5	1528	1792	6	0,15	4,5	6,7	4,5
1800	1932	2060	-	12	9,5	1834	2146	8	0,15	4,5	6,7	4,5

8.1

8.2 Sealed spherical roller bearings d 25 – 90 mm

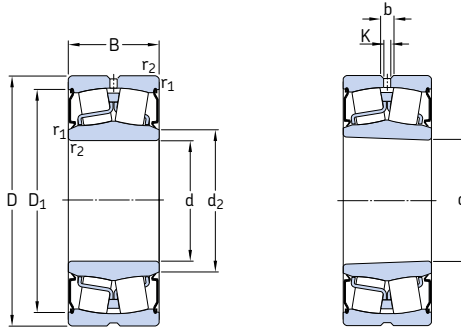

Cylindrical bore

Tapered bore

Principal dimensions		Basic load ratings		Fatigue load limit	Limiting speed	Mass	Designations	
d	D	B	dynamic C	static C ₀	P _u	r/min	Bearing with cylindrical bore	tapered bore
mm			kN		kN		-	
25	52	23	49	44	4,75	3 600	0,26 * BS2-2205-2CS/VT143	-
30	62	25	64	60	6,4	2 800	0,34 * BS2-2206-2CS/VT143	-
35	72	28	86,5	85	9,3	2 400	0,52 * BS2-2207-2CS/VT143	-
40	80	28	96,5	90	9,8	2 200	* BS2-2208-2CS/VT143	* BS2-2208-2CSK/VT143
	90	38	150	140	15	1 900	* BS2-2308-2CS/VT143	-
45	85	28	102	98	10,8	2 000	* BS2-2209-2CS/VT143	* BS2-2209-2CSK/VT143
	100	42	183	183	19,6	1 500	* BS2-2309-2CS/VT143	-
50	90	28	104	108	11,8	1 900	* BS2-2210-2CS/VT143	* BS2-2210-2CSK/VT143
	110	45	220	224	24	1 400	* BS2-2310-2CS/VT143	-
55	100	31	125	127	13,7	1 700	* BS2-2211-2CS/VT143	* BS2-2211-2CSK/VT143
	120	49	270	280	30	1 400	* BS2-2311-2CS/VT143	-
60	110	34	156	166	18,6	1 600	* BS2-2212-2CS/VT143	* BS2-2212-2CSK/VT143
	130	53	310	335	36,5	1 100	* BS2-2312-2CS/VT143	-
65	100	35	132	173	20,4	1 200	* 24013-2CS5W/VT143	-
	120	38	193	216	24	1 500	* BS2-2213-2CS/VT143	* BS2-2213-2CSK/VT143
	140	56	340	360	38	1 000	* BS2-2313-2CS/VT143	-
70	125	38	208	228	25,5	1 400	* BS2-2214-2CS/VT143	* BS2-2214-2CSK/VT143
	150	60	400	430	45	900	* BS2-2314-2CS/VT143	-
75	115	40	173	232	28,5	1 000	* 24015-2CS2/VT143	-
	130	38	212	240	26,5	1 300	* BS2-2215-2CS/VT143	* BS2-2215-2CSK/VT143
	160	64	440	475	48	950	* BS2-2315-2CS/VT143	-
80	140	40	236	270	29	1 200	* BS2-2216-2CS/VT143	* BS2-2216-2CSK/VT143
	170	67	490	540	54	800	* BS2-2316-2CS/VT143	-
85	150	44	285	325	34,5	1 100	* BS2-2217-2CS/VT143	* BS2-2217-2CSK/VT143
90	160	48	325	375	39	1 000	* BS2-2218-2CS/VT143	* BS2-2218-2CSK/VT143
	160	52,4	355	440	48	750	* 23218-2CS/VT143	-

* SKF Explorer bearing

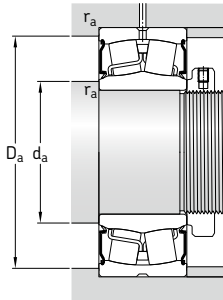

Dimensions					Abutment and fillet dimensions					Calculation factors			
d	d ₂	D ₁	b	K	r _{1,2} min.	d _a min.	d _a max.	D _a max.	r _a max.	e	Y ₁	Y ₂	Y ₀
mm										-			
25	30	46,6	3,7	2	1	30	30	46,4	1	0,35	1,9	2,9	1,8
30	36,2	55,7	3,7	2	1	35,6	36	56,4	1	0,31	2,2	3,3	2,2
35	43	63,7	3,7	2	1,1	42	43	65	1	0,31	2,2	3,3	2,2
40	47,2	73	5,5	3	1,1	47	47	73	1	0,28	2,4	3,6	2,5
	47,5	81	5,5	3	1,5	47,5	47,5	81	1,5	0,37	1,8	2,7	1,8
45	53	77,1	5,5	3	1,1	52	53	78	1	0,26	2,6	3,9	2,5
	55	89,1	6	3	1,5	54	55	91	1,5	0,37	1,8	2,7	1,8
50	58,1	82,1	5,5	3	1,1	57	58	83	1	0,24	2,8	4,2	2,8
	61,5	97,6	6	3	2	61	61,5	99	2	0,37	1,8	2,7	1,8
55	64	91,9	6	3	1,5	64	64	91	1,5	0,24	2,8	4,2	2,8
	67,5	109	5,5	3	2	66	67,5	109	2	0,35	1,9	2,9	1,8
60	69,1	102	6	3	1,5	69	69	101	1,5	0,24	2,8	4,2	2,8
	75	118	8,3	4,5	2,1	72	75	118	2	0,35	1,9	2,9	1,8
65	71,6	92,8	-	-	1,1	71	71,5	94	1	0,27	2,5	3,7	2,5
	76,5	111	5,5	3	1,5	74	76,5	111	1,5	0,24	2,8	4,2	2,8
	78,7	126	8,3	4,5	2,1	77	78,5	128	2	0,35	1,9	2,9	1,8
70	80,1	115	6	3	1,5	79	80	116	1,5	0,23	2,9	4,4	2,8
	86,7	137	8,3	4,5	2,1	82	86,5	138	2	0,33	2	3	2
75	81,8	105	5,5	3	1,1	81	81,5	109	1	0,28	2,4	3,6	2,5
	84,3	119	6	3	1,5	84	84	121	1,5	0,22	3	4,6	2,8
	88,2	144	8,3	4,5	2,1	87	88	148	2	0,35	1,9	2,9	1,8
80	91,7	128	6	3	2	91	91,5	129	2	0,22	3	4,6	2,8
	94,2	153	8,3	4,5	2,1	92	94	158	2	0,35	1,9	2,9	1,8
85	98,2	138	6	3	2	96	98	139	2	0,22	3	4,6	2,8
90	102	148	6	3	2	101	102	149	2	0,24	2,8	4,2	2,8
	103	148	6	3	2	101	103	149	2	0,31	2,2	3,3	2,2

8.2 Sealed spherical roller bearings d 95 – 140 mm

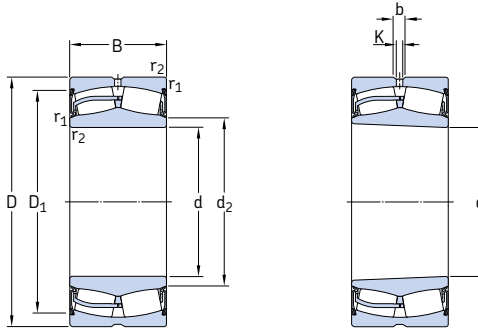

Cylindrical bore

Tapered bore

Principal dimensions		Basic load ratings		Fatigue load limit	Limiting speed	Mass	Designations	Designations	
d	D	B	dynamic C	static C ₀	P _u	r/min	kg	Bearing with cylindrical bore	tapered bore
mm			kN	kN	kN	r/min	kg	–	–
95	170	51	380	450	46,5	950	4,65	* B52-2219-2CS5/VT143	* B52-2219-2CS5K/VT143
100	150	50	285	415	45,5	800	3,15	* 24020-2CS5/VT143	–
	165	52	365	490	53	850	4,55	* 23120-2CS5/VT143	–
	165	65	455	640	68	670	5,65	* 24120-2CS5/VT143	–
	180	55	425	490	49	900	5,5	* B52-2220-2CS5/VT143	* B52-2220-2CS5K/VT143
	180	60,3	475	600	63	700	6,85	* 23220-2CS/VT143	–
110	170	45	310	440	46,5	900	3,8	* 23022-2CS/VT143	–
	170	60	415	620	67	670	5	* 24022-2CS5/VT143	–
	180	56	430	585	61	800	5,75	* 23122-2CS5/VT143	* 23122-2CS5K/VT143
	180	69	520	750	78	630	7,1	* 24122-2CS5/VT143	–
	200	63	560	640	63	800	7,6	* B52-2222-2CS5/VT143	* B52-2222-2CS5K/VT143
	200	69,8	600	765	76,5	640	9,85	* 23222-2CS5/VT143	* 23222-2CS5K/VT143
120	180	46	355	510	52	850	4,2	* 23024-2CS5/VT143	–
	180	60	430	670	68	670	5,45	* 24024-2CS5/VT143	–
	200	80	655	950	95	560	10,5	* 24124-2CS5/VT143	–
	215	69	630	765	73,5	750	9,75	* B52-2224-2CS5/VT143	* B52-2224-2CS5K/VT143
	215	76	695	930	93	600	12	* 23224-2CS5/VT143	* 23224-2CS5K/VT143
	260	86	980	1 120	100	600	23	* 22324-2CS5/VT143	* 22324-2CS5K/VT143
130	200	52	430	610	62	800	6	* 23026-2CS5/VT143	* 23026-2CS5K/VT143
	200	69	540	815	81,5	600	8,05	* 24026-2CS5/VT143	–
	210	80	680	1 000	100	530	11	* 24126-2CS5/VT143	–
	230	75	735	930	88	700	11	* B52-2226-2CS5/VT143	* B52-2226-2CS5K/VT143
	230	80	780	1 060	104	530	14,5	* 23226-2CS5/VT143	* 23226-2CS5K/VT143
	280	93	1 120	1 320	114	500	29	* 22326-2CS5/VT143	* 22326-2CS5K/VT143
140	210	53	465	680	68	700	6,55	* 23028-2CS5/VT143	* 23028-2CS5K/VT143
	210	69	570	900	88	560	8,55	* 24028-2CS5/VT143	–
	225	85	765	1 160	112	450	13,5	* 24128-2CS5/VT143	–
	250	68	710	900	86,5	670	14	* 22228-2CS5/VT143	* 22228-2CS5K/VT143
	250	88	915	1 250	120	480	19	* 23228-2CS5/VT143	* 23228-2CS5K/VT143
	300	102	1 290	1 560	132	430	36,5	* 22328-2CS5/VT143	* 22328-2CS5K/VT143

* SKF Explorer bearing

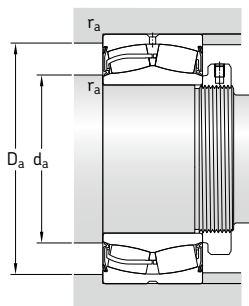

Dimensions						Abutment and fillet dimensions				Calculation factors			
d	d ₂	D ₁	b	K	r _{1,2} min.	d _a min.	d _a max.	D _a max.	r _a max.	e	Y ₁	Y ₂	Y ₀
mm						mm				-			
95	108	158	8,3	4,5	2,1	107	108	158	2	0,24	2,8	4,2	2,8
100	108	139	6	3	1,5	107	108	143	1,5	0,28	2,4	3,6	2,5
	112	152	6	3	2	111	112	154	2	0,27	2,5	3,7	2,5
	110	152	4,4	2	2	110	110	154	2	0,35	1,9	2,9	1,8
	114	162	8,3	4,5	2,1	112	114	168	2	0,24	2,8	4,2	2,8
110	114	161	8,3	4,5	2,1	112	114	168	2	0,3	2,3	3,4	2,2
	122	157	6	3	2	119	122	161	2	0,23	2,9	4,4	2,8
	120	158	6	3	2	119	119	161	2	0,33	2	3	2
	122	166	8,3	4,5	2	121	122	169	2	0,27	2,5	3,7	2,5
	120	163	6	3	2	121	121	169	2	0,35	1,9	2,9	1,8
	126	182	8,3	4,5	2,1	122	126	188	2	0,25	2,7	4	2,5
120	126	178	8,3	4,5	2,1	122	126	188	2	0,33	2	3	2
	132	172	6	3	2	129	132	171	2	0,2	3,4	5	3,2
	130	166	6	3	2	129	130	171	2	0,28	2,4	3,6	2,5
	132	179	6	3	2	131	132	189	2	0,37	1,8	2,7	1,8
	136	193	11,1	6	2,1	132	136	203	2	0,26	2,6	3,9	2,5
	137	193	8,3	4,5	2,1	132	137	203	2	0,33	2	3	2
	147	229	13,9	7,5	3	134	147	246	2,5	0,33	2	3	2
130	145	186	8,3	4,5	2	139	145	191	2	0,21	3,2	4,8	3,2
	140	183	6	3	2	139	140	191	2	0,3	2,3	3,4	2,2
	141	190	6	3	2	141	141	199	2	0,33	2	3	2
	147	205	11,1	6	3	144	147	216	2,5	0,27	2,5	3,7	2,5
	147	209	8,3	4,5	3	144	147	216	2,5	0,31	2,2	3,3	2,2
	159	246	16,7	9	4	147	159	263	3	0,33	2	3	2
140	155	197	8,3	4,5	2	149	155	201	2	0,2	3,4	5	3,2
	151	195	6	3	2	149	151	201	2	0,28	2,4	3,6	2,5
	153	203	8,3	4,5	2,1	152	153	213	2	0,35	1,9	2,9	1,8
	161	225	11,1	6	3	154	161	236	2,5	0,24	2,8	4,2	2,8
	161	225	11,1	6	3	154	161	236	2,5	0,33	2	3	2
	169	261	16,7	9	4	157	169	283	3	0,33	2	3	2

8.2 Sealed spherical roller bearings d 150 – 200 mm

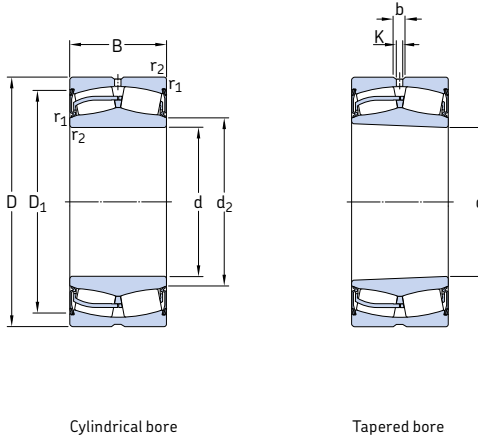

Cylindrical bore

Tapered bore

Principal dimensions		Basic load ratings		Fatigue load limit	Limiting speed	Mass	Designations		
d	D	B	dynamic C	static C ₀	P _u	r/min	Bearing with cylindrical bore	tapered bore	
mm			kN		kN		–		
150	225	56	510	750	73,5	670	7,95	* 23030-2CS5/VT143	* 23030-2CS5K/VT143
	225	75	655	1040	100	530	10,5	* 24030-2CS5/VT143	–
	250	80	850	1200	114	560	16	* 23130-2CS5/VT143	* 23130-2CS5K/VT143
	250	100	1020	1530	146	400	20	* 24130-2CS5/VT143	–
	270	73	850	1080	102	630	18	* 22230-2CS5/VT143	* 22230-2CS5K/VT143
	270	96	1080	1460	137	430	24,5	* 23230-2CS5/VT143	* 23230-2CS5K/VT143
320	108	1460	1760	146	400	43,5	* 22330-2CS5/VT143	* 22330-2CS5K/VT143	
160	240	60	585	880	83	670	9,7	* 23032-2CS5/VT143	* 23032-2CS5K/VT143
	240	80	750	1200	114	450	13	* 24032-2CS5/VT143	–
	270	86	980	1370	129	530	20,5	* 23132-2CS5/VT143	* 23132-2CS5K/VT143
	270	109	1200	1760	163	380	25	* 24132-2CS5/VT143	–
	290	80	1000	1290	118	600	22,5	* 22232-2CS5/VT143	* 22232-2CS5K/VT143
	340	114	1600	1960	160	380	52	* 22332-2CS5/VT143	* 22332-2CS5K/VT143
170	260	67	710	1080	100	630	13	* 23034-2CS5/VT143	* 23034-2CS5K/VT143
	260	90	930	1460	137	400	17,5	* 24034-2CS5/VT143	–
	280	88	1040	1500	137	480	22	* 23134-2CS5/VT143	* 23134-2CS5K/VT143
	280	109	1220	1860	170	360	27,5	* 24134-2CS5/VT143	–
	310	86	1120	1460	134	500	28,5	* 22234-2CS5/VT143	* 22234-2CS5K/VT143
180	280	74	850	1270	114	560	17	* 23036-2CS5/VT143	* 23036-2CS5K/VT143
	280	100	1080	1730	156	380	23	* 24036-2CS5/VT143	–
	300	96	1200	1800	160	430	28	* 23136-2CS5/VT143	* 23136-2CS5K/VT143
	300	118	1400	2160	196	360	34,5	* 24136-2CS5/VT143	–
	320	86	1180	1560	140	530	29	* 22236-2CS5/VT143	* 22236-2CS5K/VT143
190	320	104	1400	2080	183	400	35	* 23138-2CS5/VT143	* 23138-2CS5K/VT143
	320	128	1600	2500	212	340	43	* 24138-2CS5/VT143	–
	340	92	1290	1700	150	480	35	* 22238-2CS5/VT143	* 22238-2CS5K/VT143
200	310	82	1000	1530	137	480	22	* 23040-2CS5/VT143	* 23040-2CS5K/VT143
	340	112	1600	2360	204	380	43	* 23140-2CS5/VT143	* 23140-2CS5K/VT143
	340	140	1800	2800	232	320	53,5	* 24140-2CS5/VT143	–
	360	98	1460	1930	166	430	42	* 22240-2CS5/VT143	* 22240-2CS5K/VT143
	360	128	1860	2700	228	340	58	* 23240-2CS5/VT143	* 23240-2CS5K/VT143

* SKF Explorer bearing

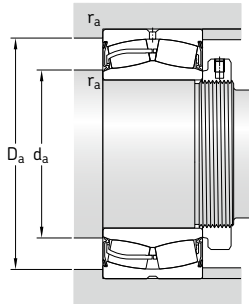

Dimensions					Abutment and fillet dimensions					Calculation factors			
d	d ₂	D ₁	b	K	r _{1,2} min.	d _a min.	d _a max.	D _a max.	r _a max.	e	Y ₁	Y ₂	Y ₀
mm						mm				-			
150	165	211	8,3	4,5	2,1	161	165	214	2	0,2	3,4	5	3,2
	162	206	6	3	2,1	161	162	214	2	0,28	2,4	3,6	2,5
	168	226	11,1	6	2,1	162	168	238	2	0,28	2,4	3,6	2,5
	163	222	8,3	4,5	2,1	162	163	238	2	0,37	1,8	2,7	1,8
	174	248	13,9	7,5	3	164	174	256	2,5	0,24	2,8	4,2	2,8
	171	243	11,1	6	3	164	171	256	2,5	0,33	2	3	2
181	281	16,7	9	4	167	181	303	3	0,33	2	3	2	
160	177	225	11,1	6	2,1	171	177	229	2	0,2	3,4	5	3,2
	173	218	8,3	4,5	2,1	171	173	229	2	0,28	2,4	3,6	2,5
	180	244	13,9	7,5	2,1	172	180	258	2	0,28	2,4	3,6	2,5
	176	239	8,3	4,5	2,1	172	176	258	2	0,37	1,8	2,7	1,8
	185	264	13,9	7,5	3	174	185	276	2,5	0,25	2,7	4	2,5
	193	296	16,7	9	4	177	193	323	3	0,33	2	3	2
170	188	243	11,1	6	2,1	181	188	249	2	0,22	3	4,6	2,8
	184	235	8,3	4,5	2,1	181	184	249	2	0,3	2,3	3,4	2,2
	190	256	13,9	7,5	2,1	182	190	268	2	0,28	2,4	3,6	2,5
	185	248	8,3	4,5	2,1	182	185	268	2	0,37	1,8	2,7	1,8
	198	282	16,7	9	4	187	198	293	3	0,25	2,7	4	2,5
	180	199	262	13,9	7,5	2,1	191	199	269	2	0,22	3	4,6
194		251	8,3	4,5	2,1	191	194	269	2	0,31	2,2	3,3	2,2
202		272	13,9	7,5	3	194	202	286	2,5	0,28	2,4	3,6	2,5
198		266	11,1	6	3	194	198	286	2,5	0,37	1,8	2,7	1,8
208		289	16,7	9	4	197	208	303	3	0,24	2,8	4,2	2,8
190		215	288	13,9	7,5	3	204	215	306	2,5	0,3	2,3	3,4
	210	282	11,1	6	3	204	210	306	2,5	0,4	1,7	2,5	1,6
	220	306	16,7	9	4	207	220	323	3	0,24	2,8	4,2	2,8
200	223	286	13,9	7,5	2,1	211	223	299	2	0,22	3	4,6	2,8
	227	306	16,7	9	3	214	227	326	2,5	0,3	2,3	3,4	2,2
	221	294	11,1	6	3	214	221	326	2,5	0,4	1,7	2,5	1,6
	232	324	16,7	9	4	217	232	343	3	0,24	2,8	4,2	2,8
	230	320	16,7	9	4	217	230	343	3	0,35	1,9	2,9	1,8

8.2 Sealed spherical roller bearings d 220 – 400 mm

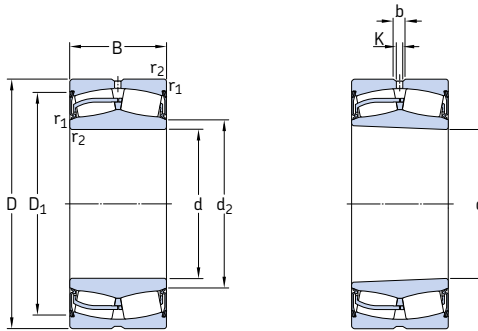

Cylindrical bore

Tapered bore

Principal dimensions		Basic load ratings		Fatigue load limit	Limiting speed	Mass	Designations		
d	D	B	dynamic C	static C ₀	P _u	r/min	Bearing with cylindrical bore	tapered bore	
mm			kN	kN			–		
220	300	60	630	1 080	93	600	12,5	* 23944-2CS/VT143	–
	340	90	1 220	1 860	163	430	29	* 23044-2CS5/VT143	* 23044-2CS5K/VT143
	370	120	1 800	2 750	232	360	53,5	* 23144-2CS5/VT143	* 23144-2CS5K/VT143
	400	108	1 760	2 360	200	380	58	* 22244-2CS5/VT143	* 22244-2CS5K/VT143
	460	145	2 700	3 450	260	300	115	* 22344-2CS5/VT143	* 22344-2CS5K/VT143
240	360	92	1 290	2 080	176	400	32	* 23048-2CS5/VT143	* 23048-2CS5K/VT143
	400	128	2 080	3 200	255	340	66,5	* 23148-2CS5/VT143	* 23148-2CS5K/VT143
260	400	104	1 600	2 550	212	360	46	* 23052-2CS5/VT143	* 23052-2CS5K/VT143
	440	144	2 550	3 900	290	320	90,5	* 23152-2CS5/VT143	* 23152-2CS5K/VT143
280	460	146	2 650	4 250	335	300	97	* 23156-2CS5/VT143	* 23156-2CS5K/VT143
300	500	160	3 200	5 100	380	260	125	* 23160-2CS5/VT143	* 23160-2CS5K/VT143
320	540	176	3 750	6 100	440	260	165	* 23164-2CS5/VT143	* 23164-2CS5K/VT143
340	580	190	4 250	6 800	490	240	210	* 23168-2CS5/VT143	* 23168-2CS5K/VT143
360	600	192	4 300	6 950	490	220	214	* 23172-2CS5/VT143	* 23172-2CS5K/VT143
400	650	200	4 650	7 650	530	150	255	* 23180-2CS5/VT143	* 23180-2CS5K/VT143

* SKF Explorer bearing

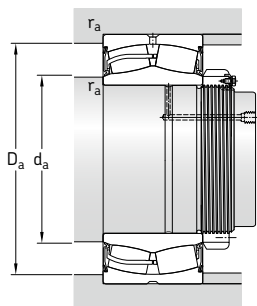

Dimensions						Abutment and fillet dimensions				Calculation factors			
d	d ₂	D ₁	b	K	r _{1,2} min.	d _a min.	d _a max.	D _a max.	r _a max.	e	Y ₁	Y ₂	Y ₀
mm						mm				-			
220	238	284	8,3	4,5	2,1	231	238	289	2	0,15	4,5	6,7	4,5
	245	314	13,9	7,5	3	233	245	327	2,5	0,22	2,8	4,2	2,8
	249	332	16,7	9	4	237	249	353	3	0,28	2,4	3,6	2,5
	257	359	16,7	9	4	237	257	383	3	0,25	2,7	4	2,5
	270	406	22,3	12	5	240	270	440	4	0,3	2,3	3,4	2,2
240	265	333	13,9	7,5	3	253	265	347	2,5	0,21	3,2	4,8	3,2
	270	360	16,7	9	4	257	270	383	3	0,28	2,4	3,6	2,5
260	289	369	16,7	9	4	275	289	385	3	0,22	3	4,6	2,8
	293	398	16,7	9	4	277	293	423	3	0,3	2,3	3,4	2,2
280	314	417	16,7	9	5	300	314	440	4	0,28	2,4	3,6	2,5
300	337	451	16,7	9	5	320	337	480	4	0,28	2,4	3,6	2,5
320	361	483	22,3	12	5	340	361	520	4	0,3	2,3	3,4	2,2
340	385	515	22,3	12	5	360	385	560	4	0,3	2,3	3,4	2,2
360	408	541	22,3	12	5	380	408	580	4	0,28	2,4	3,6	2,5
400	458	587	22,3	12	6	426	458	624	5	0,28	2,4	3,6	2,5

8.2

8.3 Spherical roller bearings for vibratory applications d 40 – 140 mm

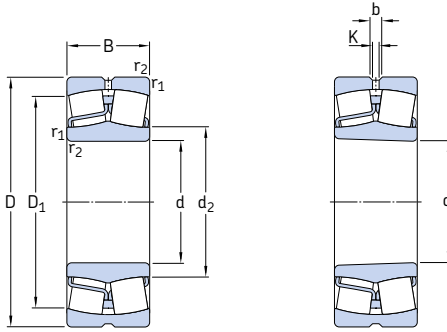

Cylindrical bore

Tapered bore

Principal dimensions			Basic load ratings		Fatigue load limit P_u	Speed ratings		Mass kg	Designations Bearing with cylindrical bore	tapered bore
d	D	B	dynamic C	static C_0		Reference speed	Limiting speed			
mm			kN		kN	r/min		–		
40	90	33	150	140	15	6 000	8 000	1,05	* 22308 E/VA405	–
45	100	36	183	183	19,6	5 300	7 000	1,4	* 22309 E/VA405	–
50	110	40	220	224	24	4 800	6 300	1,9	* 22310 E/VA405	–
55	120	43	270	280	30	4 300	5 600	2,45	* 22311 E/VA405	* 22311 EK/VA405
60	130	46	310	335	36,5	4 000	5 300	3,1	* 22312 E/VA405	* 22312 EK/VA405
65	140	48	340	360	38	3 800	5 000	3,75	* 22313 E/VA405	* 22313 EK/VA405
70	150	51	400	430	45	3 400	4 500	4,55	* 22314 E/VA405	* 22314 EK/VA405
75	160	55	440	475	48	3 200	4 300	5,55	* 22315 EJA/VA405	* 22315 EKJA/VA405
80	170	58	490	540	54	3 000	4 000	6,6	* 22316 EJA/VA405	* 22316 EKJA/VA405
85	180	60	550	620	61	2 800	3 800	7,65	* 22317 EJA/VA405	* 22317 EKJA/VA405
	180	60	550	620	61	2 800	3 800	7,65	* 22317 EJA/VA406	–
90	190	64	610	695	67	2 600	3 600	9,05	* 22318 EJA/VA405	* 22318 EKJA/VA405
95	200	67	670	765	73,5	2 600	3 400	10,5	* 22319 EJA/VA405	* 22319 EKJA/VA405
100	215	73	815	950	88	2 400	3 000	13,5	* 22320 EJA/VA405	* 22320 EKJA/VA405
	215	73	815	950	88	2 400	3 000	13,5	* 22320 EJA/VA406	–
110	240	80	950	1 120	100	2 000	2 800	18,5	* 22322 EJA/VA405	* 22322 EKJA/VA405
	240	80	950	1 120	100	2 000	2 800	18,5	* 22322 EJA/VA406	–
120	260	86	965	1 120	100	2 000	2 600	23	* 22324 CCJA/W33VA405	* 22324 CCKJA/W33VA405
	260	86	965	1 120	100	2 000	2 600	23	* 22324 CCJA/W33VA406	–
130	280	93	1 120	1 320	114	1 800	2 400	29	* 22326 CCJA/W33VA405	* 22326 CCKJA/W33VA405
	280	93	1 120	1 320	114	1 800	2 400	29	* 22326 CCJA/W33VA406	–
140	300	102	1 290	1 560	132	1 700	2 200	36,5	* 22328 CCJA/W33VA405	* 22328 CCKJA/W33VA405
	300	102	1 290	1 560	132	1 700	2 200	36,5	* 22328 CCJA/W33VA406	–

* SKF Explorer bearing

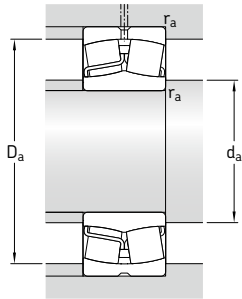

Dimensions						Abutment and fillet dimensions			Calculation factors				Permissible accelerations ¹⁾ for oil lubrication	
d	d ₂	D ₁	b	K	r _{1,2} min.	d _a min.	D _a max.	r _a max.	e	Y ₁	Y ₂	Y ₀	rotational	linear
mm						mm			-				m/s ²	
40	49,9	74,3	6	3	1,5	49	81	1,5	0,37	1,8	2,7	1,8	115 g	31 g
45	57,6	83,4	6	3	1,5	54	91	1,5	0,37	1,8	2,7	1,8	97 g	29 g
50	63,9	91,9	6	3	2	61	99	2	0,37	1,8	2,7	1,8	85 g	28 g
55	70,1	102	5,5	3	2	66	109	2	0,35	1,9	2,9	1,8	78 g	26 g
60	77,9	110	8,3	4,5	2,1	72	118	2	0,35	1,9	2,9	1,8	70 g	25 g
65	81,6	118	8,3	4,5	2,1	77	128	2	0,35	1,9	2,9	1,8	69 g	24 g
70	90,3	128	8,3	4,5	2,1	82	138	2	0,33	2	3	2	61 g	23 g
75	92,8	135	8,3	4,5	2,1	87	148	2	0,35	1,9	2,9	1,8	88 g	23 g
80	98,3	143	8,3	4,5	2,1	92	158	2	0,35	1,9	2,9	1,8	80 g	22 g
85	108	154	8,3	4,5	3	99	166	2,5	0,33	2	3	2	74 g	21 g
	108	154	8,3	4,5	3	99	166	2,5	0,33	2	3	2	74 g	21 g
90	113	161	11,1	6	3	104	176	2,5	0,33	2	3	2	68 g	21 g
95	118	168	11,1	6	3	109	186	2,5	0,33	2	3	2	64 g	20 g
100	130	184	11,1	6	3	114	201	2,5	0,33	2	3	2	56 g	20 g
	130	184	11,1	6	3	114	201	2,5	0,33	2	3	2	56 g	20 g
110	143	204	13,9	7,5	3	124	226	2,5	0,33	2	3	2	53 g	19 g
	143	204	13,9	7,5	3	124	226	2,5	0,33	2	3	2	53 g	19 g
120	152	216	13,9	7,5	3	134	246	2,5	0,35	1,9	2,9	1,8	96 g	21 g
	152	216	13,9	7,5	3	134	246	2,5	0,35	1,9	2,9	1,8	96 g	21 g
130	164	233	16,7	9	4	147	263	3	0,35	1,9	2,9	1,8	87 g	20 g
	164	233	16,7	9	4	147	263	3	0,35	1,9	2,9	1,8	87 g	20 g
140	175	247	16,7	9	4	157	283	3	0,35	1,9	2,9	1,8	78 g	20 g
	175	247	16,7	9	4	157	283	3	0,35	1,9	2,9	1,8	78 g	20 g

¹⁾ For details about permissible accelerations → page 888

8.3 Spherical roller bearings for vibratory applications d 150 – 240 mm

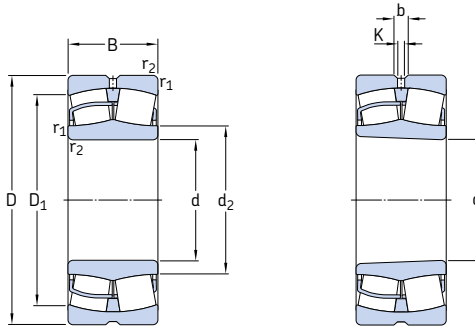

Cylindrical bore

Tapered bore

Principal dimensions			Basic load ratings		Fatigue load limit P_u	Speed ratings		Mass kg	Designations Bearing with cylindrical bore	Designations Bearing with tapered bore
d	D	B	dynamic C	static C_0		Reference speed	Limiting speed			
mm			kN		kN	r/min		kg	-	
150	320	108	1 460	1 760	146	1 600	2 000	43,5	* 22330 CCJA/W33VA405	* 22330 CCKJA/W33VA405
	320	108	1 460	1 760	146	1 600	2 000	43,5	* 22330 CCJA/W33VA406	-
160	340	114	1 600	1 960	160	1 500	1 900	52	* 22332 CCJA/W33VA405	* 22332 CCKJA/W33VA405
	340	114	1 600	1 960	160	1 500	1 900	52	* 22332 CCJA/W33VA406	-
170	360	120	1 760	2 160	176	1 400	1 800	61	* 22334 CCJA/W33VA405	* 22334 CCKJA/W33VA405
	360	120	1 760	2 160	176	1 400	1 800	61	* 22334 CCJA/W33VA406	-
180	380	126	2 000	2 450	193	1 300	1 700	71,5	* 22336 CCJA/W33VA405	* 22336 CCKJA/W33VA405
	380	126	2 000	2 450	193	1 300	1 700	71,5	* 22336 CCJA/W33VA406	-
190	400	132	2 120	2 650	208	1 200	1 600	82,5	* 22338 CCJA/W33VA405	* 22338 CCKJA/W33VA405
	400	132	2 120	2 650	208	1 200	1 600	82,5	* 22338 CCJA/W33VA406	-
200	420	138	2 320	2 900	224	1 200	1 500	95	* 22340 CCJA/W33VA405	* 22340 CCKJA/W33VA405
	420	138	2 320	2 900	224	1 200	1 500	95	* 22340 CCJA/W33VA406	-
220	460	145	2 700	3 450	260	1 000	1 400	120	* 22344 CCJA/W33VA405	* 22344 CCKJA/W33VA405
240	500	155	3 100	4 000	290	950	1 300	155	* 22348 CCJA/W33VA405	* 22348 CCKJA/W33VA405

* SKF Explorer bearing

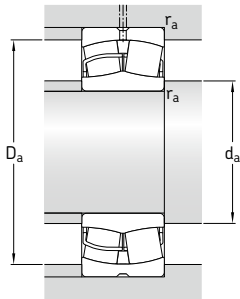

Dimensions						Abutment and fillet dimensions			Calculation factors				Permissible accelerations ¹⁾ for oil lubrication	
d	d ₂	D ₁	b	K	r _{1,2} min.	d _a min.	D _a max.	r _a max.	e	Y ₁	Y ₂	Y ₀	rotational	linear
mm						mm			-				m/s ²	
150	188	266	16,7	9	4	167	303	3	0,35	1,9	2,9	1,8	72 g	19 g
	188	266	16,7	9	4	167	303	3	0,35	1,9	2,9	1,8	72 g	19 g
160	200	282	16,7	9	4	177	323	3	0,35	1,9	2,9	1,8	69 g	18 g
	200	282	16,7	9	4	177	323	3	0,35	1,9	2,9	1,8	69 g	18 g
170	213	300	16,7	9	4	187	343	3	0,33	2	3	2	65 g	18 g
	213	300	16,7	9	4	187	343	3	0,33	2	3	2	65 g	18 g
180	224	317	22,3	12	4	197	363	3	0,35	1,9	2,9	1,8	59 g	17 g
	224	317	22,3	12	4	197	363	3	0,35	1,9	2,9	1,8	59 g	17 g
190	236	333	22,3	12	5	210	380	4	0,35	1,9	2,9	1,8	57 g	17 g
	236	333	22,3	12	5	210	380	4	0,35	1,9	2,9	1,8	57 g	17 g
200	249	351	22,3	12	5	220	400	4	0,33	2	3	2	55 g	17 g
	249	351	22,3	12	5	220	400	4	0,33	2	3	2	55 g	17 g
220	279	389	22,3	12	5	240	440	4	0,31	2,2	3,3	2,2	49 g	16 g
240	303	423	22,3	12	5	260	480	4	0,31	2,2	3,3	2,2	45 g	15 g

8.3

¹⁾ For details about permissible accelerations → page 888

8.4 Spherical roller bearings on an adapter sleeve

d_1 20 – 125 mm

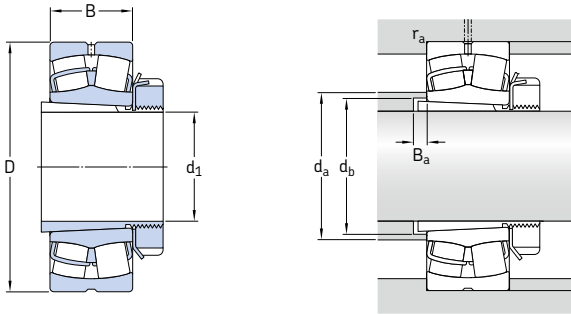

Principal dimensions			Abutment and fillet dimensions			Mass Bearing incl. sleeve	Designations Bearing ¹⁾	Adapter sleeve ²⁾	
d_1	D	B	d_a max.	d_b min.	B_a min.				
mm			mm			kg	-		
20	52	18	31	28	5	0,33	* 22205 EK	H 305	
25	62	20	37	33	5	0,39	* 22206 EK	H 306	
								* 21306 CCK	H 306
30	72	23	44	39	5	0,59	* 22207 EK	H 307	
								* 21307 CCK	H 307
35	80	23	49	44	5	0,68	* 22208 EK	H 308	
								* 21308 EK	H 308
								* 22308 EK	H 2308
40	85	23	54	50	7	0,81	* 22209 EK	H 309	
								E2.22209 K	H 309
								* 21309 EK	H 309
								* 22309 EK	H 2309
45	90	23	60	55	9	0,9	* 22210 EK	H 310	
								E2.22210 K	H 310
								* 21310 EK	H 310
								* 22310 EK	H 2310
50	100	25	65	60	10	1,1	* 22211 EK	H 311	
								E2.22211 K	H 311
								* 21311 EK	H 311
								* 22311 EK	H 2311
55	110	28	72	65	9	1,45	* 22212 EK	H 312	
								E2.22212 K	H 312
								* 21312 EK	H 312
								* 22312 EK	H 2312

¹⁾ For additional bearing data → **product tables, page 904**

²⁾ For additional adapter sleeve data → **product tables, page 1290**

* SKF Explorer bearing

E2 → SKF Energy Efficient bearing

Principal dimensions			Abutment and fillet dimensions			Mass Bearing incl. sleeve	Designations Bearing ¹⁾	Adapter sleeve ²⁾
d ₁	D	B	d _a max.	d _b min.	B _a min.			
mm			mm			kg	-	
60	120	31	80	70	8	1,95	* 22213 EK	H 313
	120	31	77	70	8	1,9	E2.22213 K	H 313
	125	31	83	75	9	2,15	* 22214 EK	H 314
	140	33	94	70	6	2,9	* 21313 EK	H 313
	140	48	81	72	5	4,2	* 22313 EK	H 2313
	150	35	101	75	6	3,7	* 21314 EK	H 314
65	150	51	90	76	6	5,35	* 22314 EK	H 2314
	130	31	87	80	12	2,45	* 22215 EK	H 315
	160	37	101	80	6	4,5	* 21315 EK	H 315
70	160	55	92	82	5	6,5	* 22315 EK	H 2315
	140	33	94	85	12	3	* 22216 EK	H 316
	170	39	106	85	6	5,3	* 21316 EK	H 316
75	170	58	98	88	6	7,65	* 22316 EK	H 2316
	150	36	101	91	12	3,7	* 22217 EK	H 317
	180	41	106	91	7	6,2	* 21317 EK	H 317
80	180	60	108	94	7	8,85	* 22317 EK	H 2317
	160	40	106	96	10	4,55	* 22218 EK	H 318
	160	52,4	106	100	18	6	* 23218 CCK/W33	H 2318
	190	43	112	96	7	7,25	* 21318 EK	H 318
85	190	64	113	100	7	10,5	* 22318 EK	H 2318
	170	43	112	102	9	5,45	* 22219 EK	H 319
	200	45	118	102	7	8,25	* 21319 EK	H 319
90	200	67	118	105	7	12	* 22319 EK	H 2319
	165	52	115	107	6	6,15	* 23120 CCK/W33	H 3120
	180	46	118	108	8	6,4	* 22220 EK	H 320
	180	60,3	117	110	19	8,75	* 23220 CCK/W33	H 2320
	215	47	118	108	7	10,5	* 21320 EK	H 320
100	215	73	130	110	7	15	* 22320 EK	H 2320
	170	45	125	118	14	5,75	* 23022 CCK/W33	H 322
	180	56	126	117	7	7,7	* 23122 CCK/W33	H 3122
	200	53	130	118	6	8,9	* 22222 EK	H 322
	200	69,8	130	121	17	12,5	* 23222 CCK/W33	H 2322
110	240	80	143	121	7	21	* 22322 EK	H 2322
	180	46	135	127	7	5,95	* 23024 CCK/W33	H 3024
	200	62	139	128	7	10	* 23124 CCK/W33	H 3124
	215	58	141	128	11	11	* 22224 EK	H 3124
	215	76	141	131	17	14,5	* 23224 CCK/W33	H 2324
115	260	86	152	131	7	25,5	* 22324 CCK/W33	H 2324
	200	52	148	137	8	8,6	* 23026 CCK/W33	H 3026
	210	64	148	138	8	12	* 23126 CCK/W33	H 3126
	230	64	152	138	8	14	* 22226 EK	H 3126
	230	80	151	142	21	18,5	* 23226 CCK/W33	H 2326
125	280	93	164	142	8	33	* 22326 CCK/W33	H 2326
	210	53	158	147	8	9,4	* 23028 CCK/W33	H 3028
	225	68	159	149	8	14,5	* 23128 CCK/W33	H 3128
	250	68	166	149	8	18	* 22228 CCK/W33	H 3128
	250	88	165	152	22	24	* 23228 CCK/W33	H 2328
300	102	175	152	8	41	* 22328 CCK/W33	H 2328	

¹⁾ For additional bearing data → **product tables, page 904**

²⁾ For additional adapter sleeve data → **product tables, page 1290**

* SKF Explorer bearing

E2 → SKF Energy Efficient bearing

8.4 Spherical roller bearings on an adapter sleeve

d_1 135 – 380 mm

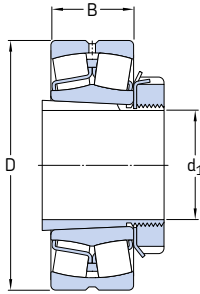

Bearing on a standard sleeve

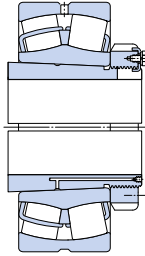

Bearing on an OH..H design sleeve

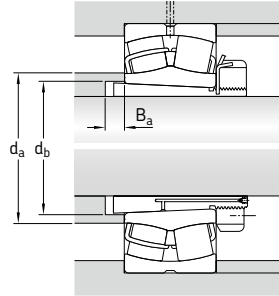

Principal dimensions			Abutment and fillet dimensions			Mass Bearing incl. sleeve	Designations Bearing ¹⁾	Adapter sleeve ²⁾
d_1	D	B	d_a max.	d_b min.	B_a min.			
mm			mm			kg	-	
135	225	56	169	158	8	11	* 23030 CCK/W33	H 3030
	250	80	172	160	8	21	* 23130 CCK/W33	H 3130
	270	73	178	160	15	23	* 22230 CCK/W33	H 3130
	270	96	175	163	20	30	* 23230 CCK/W33	H 2330
	320	108	188	163	8	47,5	* 22330 CCK/W33	H 2330
140	240	60	180	168	9	14,5	* 23032 CCK/W33	H 3032
	270	86	184	170	8	27,5	* 23132 CCK/W33	H 3132
	290	80	191	170	14	29,5	* 22232 CCK/W33	H 3132
	290	104	188	174	18	39	* 23232 CCK/W33	H 2332
	340	114	200	174	8	60	* 22332 CCK/W33	H 2332
150	260	67	191	179	9	18,5	* 23034 CCK/W33	H 3034
	280	88	195	180	8	29,5	* 23134 CCK/W33	H 3134
	310	86	203	180	10	36	* 22234 CCK/W33	H 3134
	310	110	200	185	18	46,5	* 23234 CCK/W33	H 2334
	360	120	213	185	8	69,5	* 22334 CCK/W33	H 2334
160	250	52	199	188	9	13,5	* 23936 CCK/W33	H 3936
	280	74	204	189	9	23	* 23036 CCK/W33	H 3036
	300	96	207	191	8	37	* 23136 CCK/W33	H 3136
	320	86	213	191	18	38	* 22236 CCK/W33	H 3136
	320	112	211	195	22	49,5	* 23236 CCK/W33	H 2336
	380	126	224	195	8	80	* 22336 CCK/W33	H 2336
170	260	52	209	198	10	14,5	* 23938 CCK/W33	H 3938
	290	75	216	199	10	25	* 23038 CCK/W33	H 3038
	320	104	220	202	9	44,5	* 23138 CCK/W33	H 3138
	340	92	225	202	21	46	* 22238 CCK/W33	H 3138
	340	120	222	206	21	59	* 23238 CCK/W33	H 2338
	400	132	236	206	9	93	* 22338 CCK/W33	H 2338
180	280	60	222	208	10	19	* 23940 CCK/W33	H 3940
	310	82	228	210	10	31,5	* 23040 CCK/W33	OH 3040 H
	340	112	231	212	9	55,5	* 23140 CCK/W33	OH 3140 H
	360	98	238	212	24	66	* 22240 CCK/W33	OH 3140 H
	360	128	235	216	19	70	* 23240 CCK/W33	OH 2340 H
	420	138	249	216	9	107	* 22340 CCK/W33	OH 2340 H

¹⁾ For additional bearing data → **product tables, page 904**

²⁾ For additional adapter sleeve data → **product tables, page 1290**

* SKF Explorer bearing

Principal dimensions			Abutment and fillet dimensions			Mass Bearing incl. sleeve	Designations Bearing ¹⁾	Adapter sleeve ²⁾	
d ₁	D	B	d _a max.	d _b min.	B _a min.				
mm			mm			kg	-		
200	300	60	241	229	12	22,5	* 23944 CCK/W33	OH 3944 H	
	340	90	250	231	10	39,5	* 23044 CCK/W33	OH 3044 H	
	370	120	255	233	10	67,5	* 23144 CCK/W33	OH 3144 H	
	400	108	263	233	21	74	* 22244 CCK/W33	OH 3144 H	
	400	144	259	236	11	96,5	* 23244 CCK/W33	OH 2344 H	
	460	145	279	236	10	135	* 22344 CCK/W33	OH 2344 H	
220	320	60	261	249	12	24,5	* 23948 CCK/W33	OH 3948 H	
	360	92	271	251	11	44,5	* 23048 CCK/W33	OH 3048 H	
	400	128	277	254	11	80,5	* 23148 CCK/W33	OH 3148 H	
	440	120	290	254	19	99	* 22248 CCK/W33	OH 3148 H	
	440	160	286	257	6	125	* 23248 CCK/W33	OH 2348 H	
	500	155	303	257	11	170	* 22348 CCK/W33	OH 2348 H	
240	360	75	287	270	12	35	* 23952 CCK/W33	OH 3952 H	
	400	104	295	272	11	60,5	* 23052 CCK/W33	OH 3052 H	
	440	144	301	276	11	109	* 23152 CCK/W33	OH 3152 H	
	480	130	312	276	25	130	* 22252 CCK/W33	OH 3152 H	
	480	174	312	278	2	160	* 23252 CCK/W33	OH 2352 H	
	540	165	328	278	11	215	* 22352 CCK/W33	OH 2352 H	
260	380	75	308	290	12	40	* 23956 CCK/W33	OH 3956 H	
	420	106	315	292	12	67	* 23056 CCK/W33	OH 3056 H	
	460	146	321	296	12	115	* 23156 CCK/W33	OH 3156 H	
	500	130	333	296	28	135	* 22256 CCK/W33	OH 3156 H	
	500	176	332	299	11	165	* 23256 CCK/W33	OH 2356 H	
	580	175	354	299	12	250	* 22356 CCK/W33	OH 2356 H	
280	420	90	333	312	13	58,5	* 23960 CCK/W33	OH 3960 H	
	460	118	340	313	12	90	* 23060 CCK/W33	OH 3060 H	
	500	160	345	318	12	150	* 23160 CCK/W33	OH 3160 H	
	540	140	354	318	32	170	* 22260 CCK/W33	OH 3160 H	
	540	192	356	321	12	210	* 23260 CCK/W33	OH 3260 H	
	300	440	90	354	332	13	61	* 23964 CCK/W33	OH 3964 H
480		121	360	334	13	97	* 23064 CCK/W33	OH 3064 H	
540		176	370	338	13	185	* 23164 CCK/W33	OH 3164 H	
580		150	379	338	39	200	* 22264 CCK/W33	OH 3164 H	
580		208	382	343	13	260	* 23264 CCK/W33	OH 3264 H	
320		460	90	373	352	14	67,5	* 23968 CCK/W33	OH 3968 H
	520	133	385	355	14	130	* 23068 CCK/W33	OH 3068 H	
	580	190	394	360	14	250	* 23168 CCK/W33	OH 3168 H	
	620	224	427	364	14	335	* 23268 CCK/W33	OH 3268 H	
	340	480	90	394	372	14	70,5	* 23972 CCK/W33	OH 3972 H
		540	134	404	375	14	135	* 23072 CCK/W33	OH 3072 H
600		192	418	380	14	260	* 23172 CCK/W33	OH 3172 H	
650		170	454	380	36	375	* 22272 CCK/W33	OH 3172 H	
650		232	449	385	14	375	* 23272 CCK/W33	OH 3272 H	
360		520	106	419	393	15	95	* 23976 CCK/W33	OH 3976 H
	560	135	426	396	15	145	* 23076 CCK/W33	OH 3076 H	
	620	194	454	401	15	275	* 23176 CCK/W33	OH 3176 H	
	680	240	473	405	15	420	* 23276 CCK/W33	OH 3276 H	
	380	540	106	439	413	15	100	* 23980 CCK/W33	OH 3980 H
		600	148	450	417	15	180	* 23080 CCK/W33	OH 3080 H
650		200	475	421	15	325	* 23180 CCK/W33	OH 3180 H	
720		256	500	427	15	505	* 23280 CCK/W33	OH 3280 H	
820		243	534	427	28	735	* 22380 CCK/W33	OH 3280 H	

¹⁾ For additional bearing data → **product tables, page 904**

²⁾ For additional adapter sleeve data → **product tables, page 1290**

* SKF Explorer bearing

8.4 Spherical roller bearings on an adapter sleeve

d_1 400 – 1 000 mm

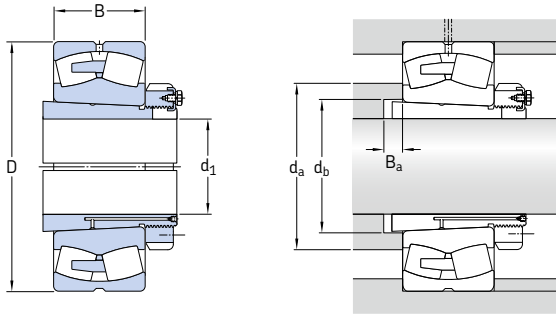

Principal dimensions			Abutment and fillet dimensions			Mass Bearing incl. sleeve	Designations Bearing ¹⁾	Adapter sleeve ²⁾
d_1	D	B	d_a max.	d_b min.	B_a min.	kg	-	
mm	mm	mm	mm	mm	mm			
400	560	106	459	433	15	105	* 23984 CCK/W33	OH 3984 H
	620	150	487	437	16	190	* 23084 CAK/W33	OH 3084 H
	700	224	483	443	16	410	* 23184 CKJ/W33	OH 3184 H
	760	272	526	446	16	590	* 23284 CAK/W33	OH 3284 H
410	600	118	484	454	17	150	* 23988 CCK/W33	OH 3988 H
	650	157	511	458	17	235	* 23088 CAK/W33	OH 3088 H
	720	226	529	463	17	430	* 23188 CAK/W33	OH 3188 H
	790	280	549	469	17	670	* 23288 CAK/W33	OH 3288 H
430	620	118	516	474	17	160	* 23992 CAK/W33	OH 3992 H
	680	163	533	478	17	265	* 23092 CAK/W33	OH 3092 H
	760	240	555	484	17	530	* 23192 CAK/W33	OH 3192 H
	830	296	574	490	17	790	* 23292 CAK/W33	OH 3292 H
450	650	128	537	496	18	185	* 23996 CAK/W33	OH 3996 H
	700	165	549	499	18	275	* 23096 CAK/W33	OH 3096 H
	790	248	579	505	18	590	* 23196 CAK/W33	OH 3196 H
	870	310	602	512	18	935	* 23296 CAK/W33	OH 3296 H
470	670	128	561	516	18	195	* 239/500 CAK/W33	OH 39/500 H
	720	167	573	519	18	290	* 230/500 CAK/W33	OH 30/500 H
	830	264	720	527	18	690	* 231/500 CA/W33	OH 31/500 H
	920	336	633	534	18	1 100	* 232/500 CAK/W33	OH 32/500 H
500	710	136	594	547	20	255	* 239/530 CAK/W33	OH 39/530 H
	780	185	613	551	20	405	* 230/530 CAK/W33	OH 30/530 H
	870	272	638	558	20	785	* 231/530 CAK/W33	OH 31/530 H
	980	355	670	566	20	1 360	* 232/530 CAK/W33	OH 32/530 H
530	750	140	627	577	20	260	* 239/560 CAK/W33	OH 39/560 H
	820	195	646	582	20	445	* 230/560 CAK/W33	OH 30/560 H
	920	280	675	589	20	880	* 231/560 CAK/W33	OH 31/560 H
	1 030	365	706	595	20	1 490	* 232/560 CAK/W33	OH 32/560 H

¹⁾ For additional bearing data → **product tables, page 904**

²⁾ For additional adapter sleeve data → **product tables, page 1290**

* SKF Explorer bearing

Principal dimensions			Abutment and fillet dimensions			Mass Bearing incl. sleeve	Designations Bearing ¹⁾	Adapter sleeve ²⁾
d ₁	D	B	d _a max.	d _b min.	B _a min.			
mm			mm			kg	–	
560	800	150	671	619	22	330	* 239/600 CAK/W33	OH 39/600 H
	870	200	685	623	22	525	* 230/600 CAK/W33	OH 30/600 H
	980	300	722	629	22	1 070	* 231/600 CAK/W33	OH 31/600 H
	1 090	388	754	639	22	1 780	* 232/600 CAK/W33	OH 32/600 H
600	850	165	708	650	22	385	* 239/630 CAK/W33	OH 39/630 H
	920	212	727	654	22	595	* 230/630 CAK/W33	OH 30/630 H
	1 030	315	755	663	22	1 240	* 231/630 CAK/W33	OH 31/630 H
630	900	170	752	691	22	455	* 239/670 CAK/W33	OH 39/670 H
	980	230	772	696	22	755	* 230/670 CAK/W33	OH 30/670 H
	1 090	336	804	705	22	1 510	* 231/670 CAK/W33	OH 31/670 H
	1 220	438	832	711	22	2 540	* 232/670 CAK/W33	OH 32/670 H
670	950	180	794	732	26	525	* 239/710 CAK/W33	OH 39/710 H
	1 030	236	816	736	26	860	* 230/710 CAK/W33	OH 30/710 H
	1 150	345	851	745	26	1 750	* 231/710 CAK/W33	OH 31/710 H
	1 280	450	875	753	26	3 000	* 232/710 CAK/W33	OH 32/710 H
710	1 000	185	838	772	26	605	* 239/750 CAK/W33	OH 39/750 H
	1 090	250	859	778	26	990	* 230/750 CAK/W33	OH 30/750 H
	1 220	365	900	787	26	2 050	* 231/750 CAK/W33	OH 31/750 H
	1 360	475	940	795	26	3 490	* 232/750 CAK/W33	OH 32/750 H
750	1 060	195	891	822	28	730	* 239/800 CAK/W33	OH 39/800 H
	1 150	258	917	829	28	1 200	* 230/800 CAK/W33	OH 30/800 H
	1 280	375	949	838	28	2 430	* 231/800 CAK/W33	OH 31/800 H
800	1 120	200	946	872	28	950	* 239/850 CAK/W33	OH 39/850 H
	1 220	272	972	880	28	1 390	* 230/850 CAK/W33	OH 30/850 H
	1 360	400	1 013	890	28	2 800	* 231/850 CAK/W33	OH 31/850 H
850	1 180	206	996	924	30	930	* 239/900 CAK/W33	OH 39/900 H
	1 280	280	1 025	931	30	1 580	* 230/900 CAK/W33	OH 30/900 H
900	1 250	224	1 056	976	30	1 120	* 239/950 CAK/W33	OH 39/950 H
	1 360	300	1 086	983	30	1 870	* 230/950 CAK/W33	OH 30/950 H
950	1 420	308	1 139	1 034	33	2 070	* 230/1000 CAKF/W33	OH 30/1000 H
	1 580	462	1 185	1 047	33	4 340	* 231/1000 CAKF/W33	OH 31/1000 H
1 000	1 400	250	1 171	1 087	33	1 590	* 239/1060 CAK/W33	OH 39/1060 H
	1 500	325	1 205	1 087	33	2 800	* 230/1060 CAKF/W33	OH 30/1060 H

8.4

¹⁾ For additional bearing data → **product tables, page 904**

²⁾ For additional adapter sleeve data → **product tables, page 1290**

* SKF Explorer bearing

8.5 Spherical roller bearings on a withdrawal sleeve

d_1 35 – 135 mm

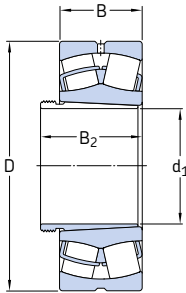

Principal dimensions				Mass Bearing incl. sleeve	Designations Bearing ¹⁾	Withdrawal sleeve ²⁾
d_1	D	B	B_2 ³⁾			
mm				kg	-	
35	80	23	32	0,6	* 22208 EK	AH 308
	90	23	32	0,84	* 21308 EK	AH 308
	90	33	43	1,2	* 22308 EK	AH 2308
40	85	23	34	0,7	* 22209 EK	AH 309
	85	23	34	0,69	E2.22209 K	AH 309
	100	25	34	1,1	* 21309 EK	AH 309
	100	36	47	1,55	* 22309 EK	AH 2309
45	90	23	38	0,75	* 22210 EK	AHX 310
	90	23	38	0,75	E2.22210 K	AHX 310
	110	27	38	1,45	* 21310 EK	AHX 310
	110	40	53	2,1	* 22310 EK	AHX 2310
50	100	25	40	0,95	* 22211 EK	AHX 311
	100	25	40	0,98	E2.22211 K	AHX 311
	120	29	40	1,8	* 21311 EK	AHX 311
	120	43	57	2,7	* 22311 EK	AHX 2311
55	110	28	43	1,3	* 22212 EK	AHX 312
	110	28	43	1,35	E2.22212 K	AHX 312
	130	31	43	2,2	* 21312 EK	AHX 312
	130	46	61	3,3	* 22312 EK	AHX 2312
60	120	31	45	1,7	* 22213 EK	AH 313 G
	120	31	45	1,7	E2.22213 K	AH 313 G
	140	33	45	2,75	* 21313 EK	AH 313 G
	140	48	64	4,1	* 22313 EK	AH 2313 G
65	125	31	47	1,8	* 22214 EK	AH 314 G
	150	35	47	3,35	* 21314 EK	AH 314 G
	150	51	68	4,9	* 22314 EK	AHX 2314 G

¹⁾ For additional bearing data → product tables, page 904

²⁾ For additional withdrawal sleeve data → product tables, page 1310

³⁾ Width before the sleeve is driven into the bearing bore

* SKF Explorer bearing

E2 → SKF Energy Efficient bearing

Principal dimensions				Mass	Designations	Withdrawal	
d_1	D	B	$B_2^{3)}$	Bearing incl. sleeve	Bearing ¹⁾	sleeve ²⁾	
mm				kg	-		
70	130	31	49	1,95	* 22215 EK	AH 315 G	
	160	37	49	4,15	* 21315 EK	AH 315 G	
	160	55	72	6	* 22315 EK	AHX 2315 G	
75	140	33	52	2,4	* 22216 EK	AH 316	
	170	39	52	4,75	* 21316 EK	AH 316	
	170	58	75	7	* 22316 EK	AHX 2316	
80	150	36	56	3,05	* 22217 EK	AHX 317	
	180	41	56	5,55	* 21317 EK	AHX 317	
	180	60	78	8,15	* 22317 EK	AHX 2317	
85	160	40	57	3,7	* 22218 EK	AHX 318	
	160	52,4	67	5	* 23218 CCK/W33	AHX 3218	
	190	43	57	6,4	* 21318 EK	AHX 318	
	190	64	83	9,5	* 22318 EK	AHX 2318	
90	170	43	61	4,6	* 22219 EK	AHX 319	
	200	45	61	7,4	* 21319 EK	AHX 319	
	200	67	89	11	* 22319 EK	AHX 2319	
95	165	52	68	5	* 23120 CCK/W33	AHX 3120	
	180	46	63	5,4	* 22220 EK	AHX 320	
	180	60,3	77	7,3	* 23220 CCK/W33	AHX 3220	
	215	47	63	9,1	* 21320 EK	AHX 320	
	215	73	94	14	* 22320 EK	AHX 2320	
105	180	56	72	6,35	* 23122 CCK/W33	AHX 3122	
	180	69	91	7,7	* 24122 CCK30/W33	AH 24122	
	200	53	72	7,5	* 22222 EK	AHX 3122	
	200	69,8	86	10,5	* 23222 CCK/W33	AHX 3222 G	
	240	80	102	19,5	* 22322 EK	AHX 2322 G	
115	180	46	64	4,8	* 23024 CCK/W33	AHX 3024	
	180	60	82	5,95	* 24024 CCK30/W33	AH 24024	
	200	62	79	8,7	* 23124 CCK/W33	AHX 3124	
	200	80	102	11	* 24124 CCK30/W33	AH 24124	
	215	58	79	9,55	* 22224 EK	AHX 3124	
	215	76	94	13	* 23224 CCK/W33	AHX 3224 G	
	260	86	109	24	* 22324 CCK/W33	AHX 2324 G	
125	200	52	71	6,75	* 23026 CCK/W33	AHX 3026	
	200	69	93	8,65	* 24026 CCK30/W33	AH 24026	
	210	64	82	9,6	* 23126 CCK/W33	AHX 3126	
	210	80	104	11,5	* 24126 CCK30/W33	AH 24126	
	230	64	82	11,5	* 22226 EK	AHX 3126	
	230	80	102	15,5	* 23226 CCK/W33	AHX 3226 G	
	280	93	119	30,5	* 22326 CCK/W33	AHX 2326 G	
	135	210	53	73	7,35	* 23028 CCK/W33	AHX 3028
		210	69	93	9,2	* 24028 CCK30/W33	AH 24028
225		68	88	11,5	* 23128 CCK/W33	AHX 3128	
225		85	109	14,5	* 24128 CCK30/W33	AH 24128	
250		68	88	15	* 22228 CCK/W33	AHX 3128	
250		88	109	20,5	* 23228 CCK/W33	AHX 3228 G	
300		102	130	38	* 22328 CCK/W33	AHX 2328 G	

1) For additional bearing data → **product tables, page 904**

2) For additional withdrawal sleeve data → **product tables, page 1310**

3) Width before the sleeve is driven into the bearing bore

* SKF Explorer bearing

8.5 Spherical roller bearings on a withdrawal sleeve

d_1 145 – 280 mm

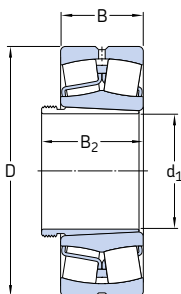

Bearing on an AH sleeve

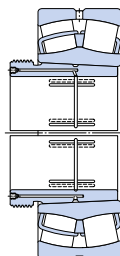

Bearing on an AOH sleeve

Principal dimensions				Mass Bearing incl. sleeve	Designations Bearing ¹⁾	Withdrawal sleeve ²⁾
d_1	D	B	B_2 ³⁾			
mm				kg	–	
145	225	56	77	8,85	* 23030 CCK/W33	AHX 3030
	225	75	101	11,5	* 24030 CCK30/W33	AH 24030
	250	80	101	17	* 23130 CCK/W33	AHX 3130 G
	250	100	126	21	* 24130 CCK30/W33	AH 24130
	270	73	101	19	* 22230 CCK/W33	AHX 3130 G
	270	96	119	26	* 23230 CCK/W33	AHX 3230 G
	320	108	140	45,5	* 22330 CCK/W33	AHX 2330 G
150	240	60	82	11,5	* 23032 CCK/W33	AH 3032
	240	80	106	15	* 24032 CCK30/W33	AH 24032
	270	86	108	23	* 23132 CCK/W33	AH 3132 G
	270	109	135	28,5	* 24132 CCK30/W33	AH 24132
	290	80	108	25	* 22232 CCK/W33	AH 3132 G
	290	104	130	34,5	* 23232 CCK/W33	AH 3232 G
	340	114	146	56	* 22332 CCK/W33	AH 2332 G
160	260	67	90	15	* 23034 CCK/W33	AH 3034
	260	90	117	20	* 24034 CCK30/W33	AH 24034
	280	88	109	25	* 23134 CCK/W33	AH 3134 G
	280	109	136	30	* 24134 CCK30/W33	AH 24134
	310	86	109	31	* 22234 CCK/W33	AH 3134 G
	310	110	140	41	* 23234 CCK/W33	AH 3234 G
	360	120	152	65	* 22334 CCK/W33	AH 2334 G
170	280	74	98	19,5	* 23036 CCK/W33	AH 3036
	280	100	127	25,5	* 24036 CCK30/W33	AH 24036
	300	96	122	32	* 23136 CCK/W33	AH 3136 G
	300	118	145	37	* 24136 CCK30/W33	AH 24136
	320	86	110	32,5	* 22236 CCK/W33	AH 2236 G
	320	112	146	43,5	* 23236 CCK/W33	AH 3236 G
	380	126	160	76	* 22336 CCK/W33	AH 2336 G

¹⁾ For additional bearing data → **product tables, page 904**

²⁾ For additional withdrawal sleeve data → **product tables, page 1310**

³⁾ Width before the sleeve is driven into the bearing bore

* SKF Explorer bearing

Principal dimensions				Mass	Designations	Withdrawal	
d ₁	D	B	B ₂ ³⁾	Bearing incl. sleeve	Bearing ¹⁾	sleeve ²⁾	
mm				kg	-		
180	290	75	102	21	* 23038 CCK/W33	AH 3038 G	
	290	100	131	27,5	* 24038 CCK30/W33	AH 24038	
	320	104	131	38,5	* 23138 CCK/W33	AH 3138 G	
	320	128	159	46,5	* 24138 CCK30/W33	AH 24138	
	340	92	117	39,5	* 22238 CCK/W33	AH 2238 G	
	340	120	152	52,5	* 23238 CCK/W33	AH 3238 G	
	400	132	167	87,5	* 22338 CCK/W33	AH 2338 G	
	190	310	82	108	26,5	* 23040 CCK/W33	AH 3040 G
		310	109	140	34,5	* 24040 CCK30/W33	AH 24040
340		112	140	48,5	* 23140 CCK/W33	AH 3140	
340		140	171	57,5	* 24140 CCK30/W33	AH 24140	
360		98	123	47	* 22240 CCK/W33	AH 2240	
360		128	160	63	* 23240 CCK/W33	AH 3240	
420		138	177	100	* 22340 CCK/W33	AH 2340	
200		340	90	117	36,5	* 23044 CCK/W33	AOH 3044 G
		340	118	152	47,5	* 24044 CCK30/W33	AOH 24044
	370	120	151	61,5	* 23144 CCK/W33	AOH 3144	
	370	150	184	76	* 24144 CCK30/W33	AOH 24144	
	400	108	136	68	* 22244 CCK/W33	AOH 2244	
	400	144	189	93	* 23244 CCK/W33	AOH 3244	
	460	145	189	130	* 22344 CCK/W33	AOH 2344	
	220	360	92	123	40,5	* 23048 CCK/W33	AOH 3048
		360	118	153	50,5	* 24048 CCK30/W33	AOH 24048
400		128	161	76,5	* 23148 CCK/W33	AOH 3148	
400		160	195	91,5	* 24148 CCK30/W33	AOH 24148	
440		120	150	95	* 22248 CCK/W33	AOH 2248	
440		160	197	120	* 23248 CCK/W33	AOH 3248	
500		155	197	165	* 22348 CCK/W33	AOH 2348	
240		400	104	135	56,5	* 23052 CCK/W33	AOH 3052
		400	140	178	75	* 24052 CCK30/W33	AOH 24052 G
	440	144	179	105	* 23152 CCK/W33	AOH 3152 G	
	440	180	218	120	* 24152 CCK30/W33	AOH 24152	
	480	130	161	120	* 22252 CCK/W33	AOH 2252 G	
	480	174	213	155	* 23252 CCK/W33	AOH 3252 G	
	540	165	213	205	* 22352 CCK/W33	AOH 2352 G	
	260	420	106	139	62	* 23056 CCK/W33	AOH 3056
		420	140	179	79	* 24056 CCK30/W33	AOH 24056 G
460		146	183	110	* 23156 CCK/W33	AOH 3156 G	
460		180	219	130	* 24156 CCK30/W33	AOH 24156	
500		130	163	125	* 22256 CCK/W33	AOH 2256 G	
500		176	220	160	* 23256 CCK/W33	AOH 3256 G	
580		175	220	245	* 22356 CCK/W33	AOH 2356 G	
280		460	118	153	82,5	* 23060 CCK/W33	AOH 3060
		460	160	202	110	* 24060 CCK30/W33	AOH 24060 G
	500	160	200	140	* 23160 CCK/W33	AOH 3160 G	
	500	200	242	180	* 24160 CCK30/W33	AOH 24160	
	540	140	178	155	* 22260 CCK/W33	AOH 2260 G	
	540	192	236	200	* 23260 CCK/W33	AOH 3260 G	

8.5

1) For additional bearing data → product tables, page 904

2) For additional withdrawal sleeve data → product tables, page 1310

3) Width before the sleeve is driven into the bearing bore

* SKF Explorer bearing

8.5 Spherical roller bearings on a withdrawal sleeve

d_1 300 – 670 mm

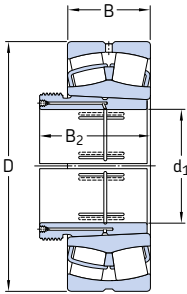

Principal dimensions				Mass Bearing incl. sleeve	Designations Bearing ¹⁾	Withdrawal sleeve ²⁾
d_1	D	B	B_2 ³⁾			
mm				kg	–	
300	480	121	157	89	* 23064 CCK/W33	AOH 3064 G
	480	160	202	115	* 24064 CCK30/W33	AOH 24064 G
	540	176	217	175	* 23164 CCK/W33	AOH 3164 G
	540	218	260	225	* 24164 CCK30/W33	AOH 24164
	580	150	190	185	22264 CACK/W33	AOH 2264 G
	580	208	254	250	* 23264 CCK/W33	AOH 3264 G
320	520	133	171	120	* 23068 CCK/W33	AOH 3068 G
	520	180	225	160	* 24068 CCK30/W33	AOH 24068
	580	190	234	225	* 23168 CCK/W33	AOH 3168 G
	580	243	288	295	* 24168 ECCK30J/W33	AOH 24168
	620	224	273	315	* 23268 CAK/W33	AOH 3268 G
340	540	134	176	125	* 23072 CCK/W33	AOH 3072 G
	540	180	226	165	* 24072 CCK30/W33	AOH 24072
	600	192	238	235	* 23172 CCK/W33	AOH 3172 G
	600	243	289	295	* 24172 ECCK30J/W33	AOH 24172
	650	170	238	275	* 22272 CAK/W33	AOH 3172 G
	650	232	283	345	* 23272 CAK/W33	AOH 3272 G
360	560	135	180	135	* 23076 CCK/W33	AOH 3076 G
	560	180	228	170	* 24076 CCK30/W33	AOH 24076
	620	194	242	250	* 23176 CAK/W33	AOH 3176 G
	620	243	291	325	* 24176 ECAK30/W33	AOH 24176
	680	240	294	390	* 23276 CAK/W33	AOH 3276 G
380	600	148	193	165	* 23080 CCK/W33	AOH 3080 G
	600	200	248	220	* 24080 ECCK30J/W33	AOH 24080
	650	200	250	290	* 23180 CAK/W33	AOH 3180 G
	650	250	298	365	* 24180 ECAK30/W33	AOH 24180
	720	256	312	470	* 23280 CAK/W33	AOH 3280 G
	820	243	312	675	* 22380 CAK/W33	AOH 3280 G

¹⁾ For additional bearing data → **product tables, page 904**

²⁾ For additional withdrawal sleeve data → **product tables, page 1310**

³⁾ Width before the sleeve is driven into the bearing bore

* SKF Explorer bearing

Principal dimensions				Mass	Designations	Withdrawal
d_1	D	B	$B_2^{3)}$	Bearing incl. sleeve	Bearing ¹⁾	sleeve ²⁾
mm				kg	-	
400	620	150	196	175	* 23084 CAK/W33	AOH 3084 G
	620	200	252	230	* 24084 ECAK30/W33	AOH 24084
	700	224	276	375	* 23184 CKJ/W33	AOH 3184 G
	700	280	332	470	* 24184 ECAK30/W33	AOH 24184
	760	272	331	550	* 23284 CAK/W33	AOH 3284 G
420	650	157	205	200	* 23088 CAK/W33	AOHX 3088 G
	650	212	264	275	* 24088 ECAK30/W33	AOH 24088
	720	226	281	380	* 23188 CAK/W33	AOHX 3188 G
	720	280	332	490	* 24188 ECAK30/W33	AOH 24188
	790	280	341	620	* 23288 CAK/W33	AOHX 3288 G
440	680	163	213	225	* 23092 CAK/W33	AOHX 3092 G
	680	218	273	300	* 24092 ECAK30/W33	AOH 24092
	760	240	296	465	* 23192 CAK/W33	AOHX 3192 G
	760	300	355	590	* 24192 ECAK30/W33	AOH 24192
	830	296	360	725	* 23292 CAK/W33	AOHX 3292 G
460	700	165	217	235	* 23096 CAK/W33	AOHX 3096 G
	700	218	273	310	* 24096 ECAK30/W33	AOH 24096
	790	248	307	515	* 23196 CAK/W33	AOHX 3196 G
	790	308	363	635	* 24196 ECAK30/W33	AOH 24196
	870	310	376	860	* 23296 CAK/W33	AOHX 3296 G
480	720	167	221	250	* 230500 CAK/W33	AOHX 30/500 G
	720	218	276	325	* 240500 ECAK30/W33	AOH 240/500
	830	264	325	610	* 231500 CAK/W33	AOHX 31/500 G
	830	325	383	735	* 241500 ECAK30/W33	AOH 241/500
	920	336	405	1 020	* 232500 CAK/W33	AOHX 32/500 G
500	780	185	242	365	* 230530 CAK/W33	AOH 30/530
	780	250	309	455	* 240530 ECAK30/W33	AOH 240/530 G
	870	272	337	720	* 231530 CAK/W33	AOH 31/530
	870	335	394	885	* 241530 ECAK30/W33	AOH 241/530 G
	980	355	424	1 290	* 232530 CAK/W33	AOH 32/530 G
530	820	195	252	430	* 230560 CAK/W33	AOHX 30/560
	820	258	320	515	* 240560 ECAK30/W33	AOH 240/560 G
	920	280	347	850	* 231560 CAK/W33	AOH 31/560
	920	355	417	1 060	* 241560 ECK30J/W33	AOH 241/560 G
	1 030	365	434	1 500	* 232560 CAK/W33	AOHX 32/560
570	870	200	259	480	* 230600 CAK/W33	AOHX 30/600
	870	272	336	600	* 240600 ECAK30/W33	AOHX 240/600
	980	300	369	1 010	* 231600 CAK/W33	AOHX 31/600
	980	375	439	1 290	* 241600 ECAK30/W33	AOHX 241/600
	1 090	388	459	1 760	* 232600 CAK/W33	AOHX 32/600 G
600	920	212	272	575	* 230630 CAK/W33	AOH 30/630
	920	290	356	730	* 240630 ECK30J/W33	AOH 240/630 G
	1 030	315	389	1 190	* 231630 CAK/W33	AOH 31/630
	1 030	400	466	1 500	* 241630 ECAK30/W33	AOH 241/630 G
630	980	230	294	720	* 230670 CAK/W33	AOH 30/670
	980	308	374	900	* 240670 ECAK30/W33	AOH 240/670 G
	1 090	412	478	1 730	* 241670 ECAK30/W33	AOH 241/670
	1 220	438	514	2 500	* 232670 CAK/W33	AOH 32/670 G
670	1 030	236	302	800	* 230710 CAK/W33	AOHX 30/710
	1 030	315	386	1 010	* 240710 ECAK30/W33	AOH 240/710 G
	1 150	438	509	2 040	* 241710 ECAK30/W33	AOH 241/710
	1 280	450	531	2 810	* 232710 CAK/W33	AOH 32/710 G

1) For additional bearing data → **product tables, page 904**

2) For additional withdrawal sleeve data → **product tables, page 1310**

3) Width before the sleeve is driven into the bearing bore

* SKF Explorer bearing

8.5 Spherical roller bearings on a withdrawal sleeve

d_1 710 – 1 000 mm

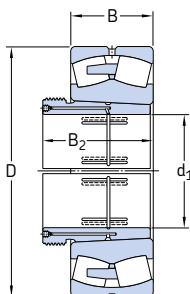

Principal dimensions				Mass Bearing incl. sleeve	Designations Bearing ¹⁾	Withdrawal sleeve ²⁾
d_1	D	B	B_2 ³⁾			
mm				kg	-	
710	1 090	250	316	950	* 230/750 CAK/W33	AOH 30/750
	1 090	335	408	1 200	* 240/750 ECAK30/W33	AOH 240/750 G
	1 220	365	441	1 930	* 231/750 CAK/W33	AOH 31/750
	1 220	475	548	2 280	* 241/750 ECAK30/W33	AOH 241/750 G
	1 360	475	556	3 280	* 232/750 CAKF/W33	AOH 32/750
750	1 150	258	326	1 100	* 230/800 CAK/W33	AOH 30/800
	1 150	345	423	1 380	* 240/800 ECAK30/W33	AOH 240/800 G
	1 280	375	456	2 200	* 231/800 CAK/W33	AOH 31/800
	1 280	475	553	2 540	* 241/800 ECAK30/W33	AOH 241/800 G
800	1 220	272	343	1 250	* 230/850 CAK/W33	AOH 30/850
	1 220	365	445	1 670	* 240/850 ECAK30/W33	AOH 240/850 G
	1 360	400	480	2 500	* 231/850 CAK/W33	AOH 31/850
	1 360	500	600	3 050	* 241/850 ECAK30F/W33	AOH 241/850
850	1 280	280	355	1 450	* 230/900 CAK/W33	AOH 30/900
	1 280	375	475	1 850	* 240/900 ECAK30/W33	AOH 240/900
	1 420	515	620	3 700	* 241/900 ECAK30F/W33	AOH 241/900
900	1 360	300	375	1 720	* 230/950 CAK/W33	AOH 30/950
	1 360	412	512	2 300	* 240/950 CAK30F/W33	AOH 240/950
	1 500	545	650	3 950	* 241/950 ECAK30F/W33	AOH 241/950
950	1 420	308	387	1 900	* 230/1000 CAKF/W33	AOH 30/1000
	1 420	412	519	2 500	* 240/1000 CAK30F/W33	AOH 240/1000
	1 580	462	547	3 950	* 231/1000 CAKF/W33	AOH 31/1000
	1 580	580	695	4 800	* 241/1000 ECAK30F/W33	AOH 241/1000
1 000	1 500	325	407	2 600	* 230/1060 CAKF/W33	AOH 30/1060
	1 500	438	548	2 950	* 240/1060 CAK30F/W33	AOH 240/1060

¹⁾ For additional bearing data → product tables, page 904

²⁾ For additional withdrawal sleeve data → product tables, page 1310

³⁾ Width before the sleeve is driven into the bearing bore

* SKF Explorer bearing

8.6 Sealed spherical roller bearings on an adapter sleeve

d_1 35 – 380 mm

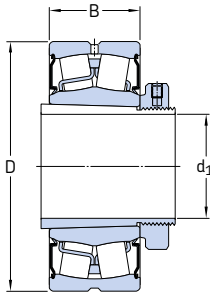

Bearing on an
E design sleeve

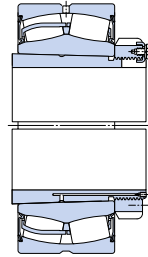

Bearing on an
OH .. H design sleeve

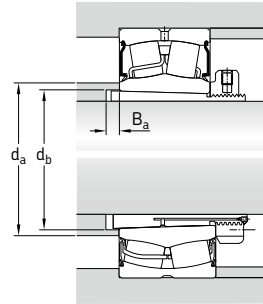

Principal dimensions			Abutment and fillet dimensions			Mass	Designations Bearing ¹⁾	Adapter sleeve ²⁾
d_1	D	B	d_a max.	d_b min.	B_a min.			
mm			mm			kg	-	
35	80	28	47	44	5	0,8	* BS2-2208-2CSK/VT143	H 2308 E
40	85	28	53	50	7	24,5	* BS2-2209-2CSK/VT143	H 309 E
45	90	28	58	55	9	1	* BS2-2210-2CSK/VT143	H 310 E
50	100	31	64	55	9	1,3	* BS2-2211-2CSK/VT143	H 311 E
55	110	34	69	60	10	1,7	* BS2-2212-2CSK/VT143	H 312 E
60	120	38	76,5	70	6	2,1	* BS2-2213-2CSK/VT143	H 2313 E
	125	38	80	70	8	2,4	* BS2-2214-2CSK/VT143	H 314 E
65	130	38	84	80	12	2,8	* BS2-2215-2CSK/VT143	H 315 E
70	140	40	91,5	85	12	3,3	* BS2-2216-2CSK/VT143	H 316 E
75	150	44	98	91	12	4,1	* BS2-2217-2CSK/VT143	H 317 E
80	160	48	102	96	10	5,1	* BS2-2218-2CSK/VT143	H 2318 E/L73 ³⁾
85	170	51	108	102	9	6,5	* BS2-2219-2CS5K/VT143	H 2319 EL
90	180	55	114	108	8	7,4	* BS2-2220-2CS5K/VT143	H 2320 E
100	180	56	122	65	9	7,7	* 23122-2CS5K/VT143	H 3122 E
	200	63	126	118	6	10	* BS2-2222-2CS5K/VT143	H 2322 E
	200	69,8	126	121	17	12,5	* 23222-2CS5K/VT143	H 2322 E
110	215	69	136	128	11	12,5	* BS2-2224-2CS5K/VT143	H 2324 EH
	215	76	137	131	17	14,5	* 23224-2CS5K/VT143	H 2324 L
	260	86	147	131	7	25,5	* 22324-2CS5K/VT143	H 2324

¹⁾ For additional bearing data → product tables, page 928

²⁾ For additional adapter sleeve data → product tables, page 1290

³⁾ Width reduced to 73 mm

* SKF Explorer bearing

Principal dimensions			Abutment and fillet dimensions			Mass	Designations Bearing ¹⁾	Adapter sleeve ²⁾
d ₁	D	B	d _a max.	d _b min.	B _a min.			
mm			mm			kg	-	
115	200	52	145	137	8	8,7	* 23026-2CS5K/VT143	H 3026 E
	230	75	147	138	8	14,5	* B52-2226-2CS5K/VT143	H 2326 L
	230	80	147	142	21	18	* 23226-2CS5K/VT143	H 2326 L
	280	93	159	142	8	33	* 22326-2CS5K/VT143	H 2326
125	210	53	155	147	8	9,4	* 23028-2CS5K/VT143	H 3028 E
	250	68	161	149	8	17,5	* 22228-2CS5K/VT143	H 3128 L
	250	88	161	152	22	24	* 23228-2CS5K/VT143	H 2328
	300	102	169	152	8	41	* 22328-2CS5K/VT143	H 2328
135	225	56	165	158	8	11,5	* 23030-2CS5K/VT143	H 3030 E
	250	80	168	160	8	20	* 23130-2CS5K/VT143	H 3130 E
	270	73	174	160	15	23	* 22230-2CS5K/VT143	H 3130
	270	96	171	163	20	30	* 23230-2CS5K/VT143	H 2330 L
	320	108	181	163	8	49	* 22330-2CS5K/VT143	H 2330
140	240	60	177	168	9	14,5	* 23032-2CS5K/VT143	H 3032 E
	270	86	180	170	8	27,5	* 23132-2CS5K/VT143	H 3132 E
	290	80	185	170	14	29,5	* 22232-2CS5K/VT143	H 3132
	340	114	193	174	8	60	* 22332-2CS5K/VT143	H 2332
150	260	67	188	179	9	18,5	* 23034-2CS5K/VT143	H 3034 E
	280	88	190	180	8	29,5	* 23134-2CS5K/VT143	H 3134 E
	310	86	198	180	10	36	* 22234-2CS5K/VT143	H 3134
160	280	74	199	189	9	23	* 23036-2CS5K/VT143	H 3036 E
	300	96	202	191	8	35	* 23136-2CS5K/VT143	H 3136 L
	320	86	208	191	18	37,5	* 22236-2CS5K/VT143	H 3136
170	320	104	215	202	9	44,5	* 23138-2CS5K/VT143	H 3138
	340	92	220	202	21	44,5	* 22238-2CS5K/VT143	H 3138
180	310	82	223	210	10	30	* 23040-2CS5K/VT143	H 3040
	340	112	227	212	9	53,5	* 23140-2CS5K/VT143	H 3140
	360	98	232	212	24	53	* 22240-2CS5K/VT143	H 3140
	360	128	229	216	19	69,5	* 23240-2CS5K/VT143	H 2340 L
200	340	90	245	231	10	38	* 23044-2CS5K/VT143	OH 3044 H
	370	120	249	233	10	66,5	* 23144-2CS5K/VT143	OH 3144 HTL
	400	108	257	233	21	71,5	* 22244-2CS5K/VT143	OH 3144 H
	460	145	270	236	10	131	* 22344-2CS5K/VT143	OH 2344 H
220	360	92	265	251	11	42,5	* 23048-2CS5K/VT143	OH 3048 HE
	400	128	270	254	11	79,5	* 23148-2CS5K/VT143	OH 3148 HTL
240	400	104	289	272	11	58	* 23052-2CS5K/VT143	OH 3052 HE
	440	144	293	276	11	105	* 23152-2CS5K/VT143	OH 3152 HTL
260	460	146	314	296	12	114	* 23156-2CS5K/VT143	OH 3156 HTL
280	500	160	337	318	12	153	* 23160-2CS5K/VT143	OH 3160 HE
300	540	176	361	338	13	192	* 23164-2CS5K/VT143	OH 3164 H
320	580	190	385	360	14	252	* 23168-2CS5K/VT143	OH 3168 HE
340	600	192	408	380	14	265	* 23172-2CS5K/VT143	OH 3172 HE
380	650	200	458	421	15	312	* 23180-2CS5K/VT143	OH 3180 HE

¹⁾ For additional bearing data → **product tables, page 928**

²⁾ For additional adapter sleeve data → **product tables, page 1290**

* SKF Explorer bearing

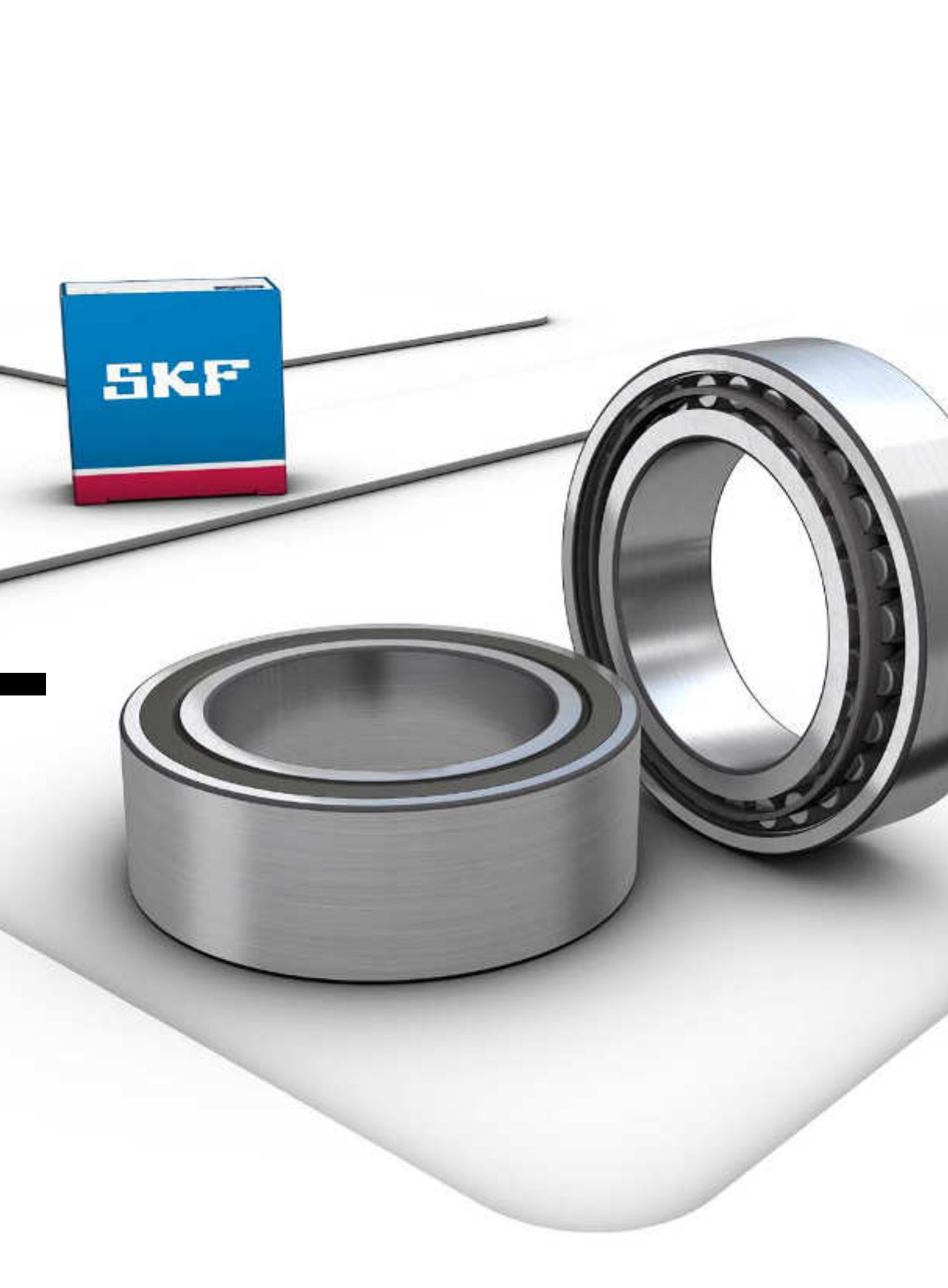

SKF

9 CARB toroidal roller bearings

Designs and variants	958	Product tables	
Factors that influence CARB bearing performance.	959	9.1 CARB toroidal roller bearings.	980
Assortment.	960	9.2 Sealed CARB toroidal roller bearings.	996
Basic design bearings.	961	9.3 CARB toroidal roller bearings on an adapter sleeve.	1000
Sealing solutions	962	9.4 CARB toroidal roller bearings on a withdrawal sleeve.	1004
Greases for sealed bearings.	962		
Bearings for vibratory applications	963		
Cages.	963		
Performance classes	963	Other CARB toroidal roller bearings	
SKF Explorer bearings	963	NoWear coated bearings	1241
Bearing data	964		
(Dimension standards, tolerances, internal clearance, misalignment, friction, starting torque, power loss, defect frequencies)			
Axial displacement	968		
Calculating the permissible axial displacement.	970		
Offset mounting	971		
Loads	972		
(Minimum load, axial load carrying capacity, equivalent loads)			
Temperature limits.	973		
Permissible speed.	973		
Design of bearing arrangements	974		
Free space on both sides of the bearing.	974		
Bearings on sleeves	975		
Appropriate bearing housings	976		
Mounting.	976		
Mounting bearings with a tapered bore	976		
Designation system	978		



Designs and variants

CARB toroidal roller bearings (→ **fig. 1**) combine the self-aligning capability of spherical roller bearings with the axial displacement ability of cylindrical roller bearings (→ **fig. 2**). CARB bearings can also have the compact cross section and high load carrying capacity normally associated with needle roller bearings.

CARB bearings are intended exclusively as non-locating bearings. They can simplify locating/non-locating bearing arrangements because thermal elongation of the shaft can be accommodated within the bearing virtually without friction. Bearing systems consisting of a spherical roller bearing in the locating position and a CARB bearing in the non-locating position (→ **fig. 6, page 162**) provide a space- and weight-saving bearing system with a low cost of ownership. CARB bearings can reduce noise and vibration levels, for example, in paper machines and fans.

CARB bearings are single row bearings with long, slightly barrel-shaped symmetrical rollers. The outer ring has a torus-shaped raceway with a profile radius extending beyond the centre of the bearing. The inner ring raceway is shaped accordingly. The rollers of CARB

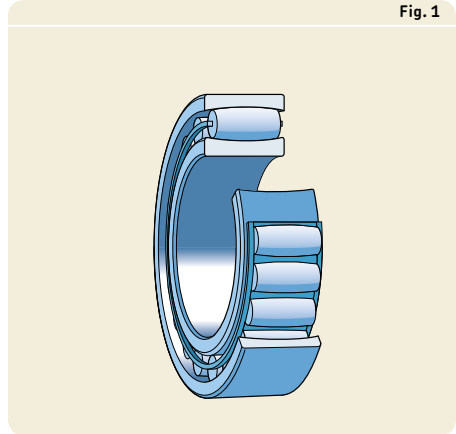

Fig. 1

bearings are self-guiding, i.e. they always adopt the position where the load is favourably distributed over the roller length, irrespective of whether the bearing rings are misaligned or axially displaced. The ability to distribute loads favourably keeps the friction and frictional heat at low levels. Lower operating temperatures extend the service life of the lubricant and the bearing.

More information

Bearing life and load ratings **63**

Design considerations **159**

Bearing systems 160

Recommended fits 169

Abutment and fillet dimensions 208

Lubrication **239**

Mounting, dismantling and bearing care **271**

Mounting instructions for individual bearings → skf.com/mount

SKF bearing maintenance handbook (ISBN 978-91-978966-4-1)

SKF Drive-up Method → skf.com/drive-up

Fig. 2

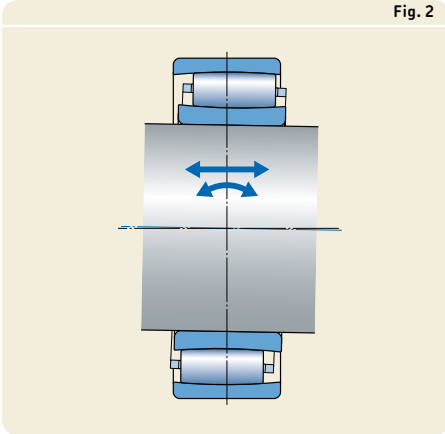

Factors that influence CARB bearing performance

Bearing performance is not only determined by load or speed ratings. There are a number of other factors that contribute to bearing performance. To a large extent, performance is influenced by the geometry of the rollers, raceways and cages, the heat treatment, as well as the surface finish of all contact surfaces. Main factors which influence CARB bearing performance include, but are not limited to:

- **Symmetrical rollers**

Symmetrical rollers self-adjust, providing optimal load distribution along the roller length. This keeps stresses low under all load conditions and extends bearing service life.

Fig. 3

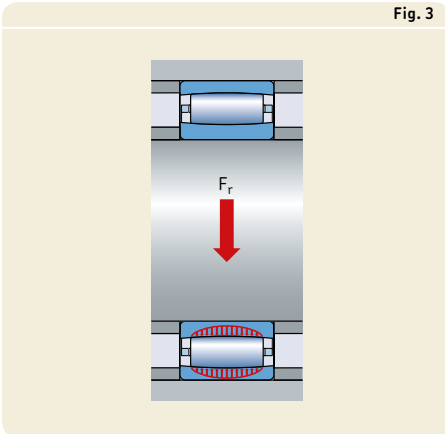

- **Roller tolerances**

The rollers in a CARB bearing are manufactured to extremely tight tolerances for dimension and form. Each roller is virtually identical in size and shape to the other rollers in the set. This optimizes load distribution over the rollers to maximize bearing service life.

- **Special roller profile**

The roller profile determines the stress distribution in the roller/raceway contact area. The special profile distributes loads more evenly along the rollers and prevents stress peaks at the roller ends to extend bearing service life (→ fig. 3).

Fig. 4

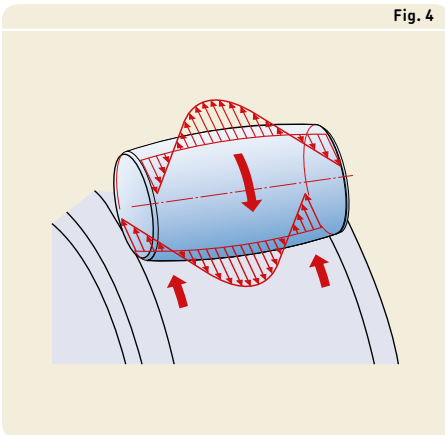

- **Self-guiding rollers**

Self-guiding rollers keep friction and frictional heat at low levels (→ fig. 4).

9 CARB toroidal roller bearings

Assortment

The assortment of CARB toroidal roller bearings matches the assortment of spherical roller bearings. The assortment also includes bearings with a low cross-sectional height to meet the requirements for minimum radial space. The majority of CARB bearings are available with either a cylindrical or tapered bore. Depending on the bearing series, the tapered bore has a taper of either 1:12 (designation suffix K) or 1:30 (designation suffix K30).

The assortment of standard bearings includes:

- basic design bearings
- sealed bearings
- bearings for vibratory applications

CARB bearings listed in this catalogue constitute the basic SKF assortment and are only part of the total assortment. For applications where the bearings are subjected to unique operating conditions, SKF can customize bearings to meet the needs of that particular application. For example, bearings for:

- paper mills or coaters in high precision execution
- very arduous operating conditions, e.g. continuous casters
- high temperature applications

For additional information about application specific CARB bearings, contact the SKF application engineering service.

Fig. 5

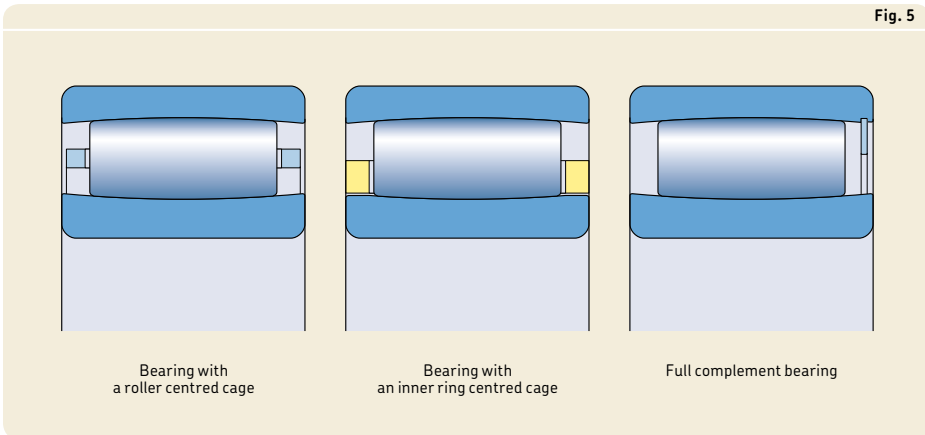

Basic design bearings

Depending on their series and size, standard CARB toroidal roller bearings are manufactured to one of the following basic designs (→ fig. 5):

- bearings with a roller centred cage
(no designation suffix, designation suffix TN9 or designation suffix M)
- bearings with an inner ring centred cage
(designation suffix MB)
- full complement bearings
(designation suffix V)

The load carrying capacity of full complement CARB bearings is considerably higher than that of same-sized bearings with a cage.

9 CARB toroidal roller bearings

Sealing solutions

The assortment of sealed bearings (→ **fig. 6**) consists of small and medium-size full complement bearings with a cylindrical bore. These bearings, which are typically used in applications where there are slow speeds and very heavy loads, can accommodate inner or outer ring rotation. The seals are designed for long service life and make the bearings virtually relubrication-free.

Sealed bearings have a double lip contact HNBR seal on one or both sides (designation suffix CS5 or 2CS5). The seals are reinforced with a sheet steel insert. They are fitted in a recess on the outer ring and seal against the inner ring raceway.

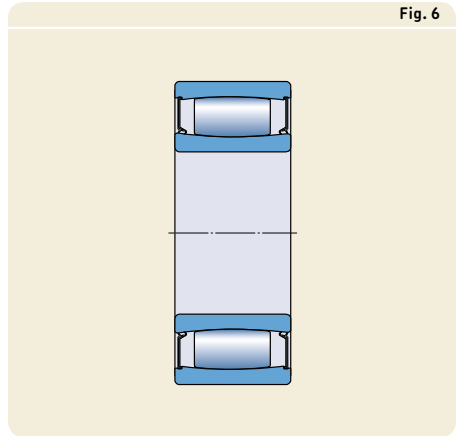

Greases for sealed bearings

Sealed CARB bearings are filled with a high-quality grease (→ **table 1**) that has good corrosion inhibiting properties. Sealed bearings with non-standard grease fills can be supplied on request.

Table 1

Technical specifications of the SKF grease for sealed CARB toroidal roller bearings

Grease	Designation suffix	Temperature range ¹⁾						Thickener	Base oil type	NLGI consistency class	Base oil viscosity [mm ² /s]	
		-50	0	50	100	150	200				250 °C	at 40°C (105 °F)
LGHB 2	GEM							Calcium complex sulphonate	Mineral	2	400	26,5
		-60	30	120	210	300	390	480 °F				

¹⁾ Refer to the SKF traffic light concept → **page 244**

Bearings for vibratory applications

For vibratory applications, SKF supplies CARB bearings with a cylindrical or tapered bore and a surface-hardened stamped steel cage (series designation C 23../C4VG114). These bearings have the same dimensions and product data as bearings in the C 23 series.

CARB bearings can be mounted with an interference fit on the shaft and in the housing because axial displacement is accommodated within the bearing. This avoids fretting corrosion, which otherwise can occur, if a radial bearing is mounted with a loose fit.

For additional information about CARB bearings in the C 23../C4VG114 series, contact the SKF application engineering service.

Cages

Cages in CARB toroidal roller bearings are an integral part of the bearing internal design. Depending on their series and size, CARB bearings are fitted with one of the following cages:

- a glass fibre reinforced PA46 cage, window-type, roller centred (designation suffix TN9)
- a stamped steel cage, window-type, roller centred (no designation suffix)
- a machined brass cage, window-type, roller centred (designation suffix M)
- a machined brass cage, prong-type, inner ring centred (designation suffix MB)

The lubricants generally used for rolling bearings do not have a detrimental effect on cage properties. However, some synthetic oils and greases with a synthetic oil base and lubricants containing a high proportion of EP additives, when used at high temperatures, can have a detrimental effect on polyamide cages. For additional information about the suitability of cages, refer to *Cages* (→ **page 37**) and *Cage materials* (→ **page 152**).

Performance classes

SKF Explorer bearings

In response to the ever-demanding performance requirements of modern machinery, SKF developed the SKF Explorer performance class of rolling bearings.

All CARB bearings are manufactured to the SKF Explorer performance class and are shown with an asterisk in the product tables. Each box is marked with the name “SKF EXPLORER”.

Bearing data

Dimension standards	Boundary dimensions: ISO 15
Tolerances	Normal When $d \leq 300$ mm: <ul style="list-style-type: none"> • width tolerance at least 50% tighter than ISO standard (→ table 2) • P5 running accuracy
For additional information (→ page 132)	Values: ISO 492 (→ tables 3 to 5, pages 137 to 139)
Internal clearance	Normal Check availability of C2, C3, C4 or C5 clearance classes Values: ISO 5753-1 <ul style="list-style-type: none"> • cylindrical bore (→ table 3, page 966) • tapered bore (→ table 4, page 967) Values are valid for unmounted bearings under zero measuring load, and with no axial displacement between the inner and outer rings.
For additional information (→ page 149)	Axial displacement of one bearing ring relative to the other gradually reduces the radial internal clearance. A CARB bearing is often used together with a spherical roller bearing. The clearance in a CARB bearing prior to mounting is slightly greater than that in a corresponding spherical roller bearing in the same clearance class. An axial displacement of the inner ring relative to ...
Misalignment	0,5° For misalignment greater than 0,5°, contact the SKF application engineering service.
(→ fig. 7, page 968)	Misalignment greater than 0,5° increases friction and reduces bearing service life. The ability to accommodate misalignment when the bearing is stationary is also limited. For CARB bearings with a machined brass cage centred on the inner ring (designation suffix MB), misalignment should never exceed 0,5°.
Friction, starting torque, power loss	Frictional moment, starting torque and power loss can be calculated as specified under <i>Friction</i> (→ page 97), or using the tools available online at skf.com/bearingcalculator .
Defect frequencies	Defect frequencies can be calculated using the tools available online at skf.com/bearingcalculator .

When $d > 300$ mm:

- P5 running accuracy on request (designation suffix C08)

... the outer ring of 6 to 8% of the bearing width reduces the operating clearance to approximately the same value as same-sized spherical roller bearings.

Misalignment displaces the rollers axially, causing them to approach the side faces of the bearing rings. Therefore, possible axial displacement is reduced (→ *Axial displacement*, page 968).

Table 2

Width tolerances for CARB bearings

Bore diameter d		Width tolerances in accordance with SKF standard Δ_{Bs}	
over	incl.	high	low
mm		μm	
18	50	0	-60
50	80	0	-60
80	120	0	-80
120	180	0	-80
180	250	0	-80
250	300	0	-100

9 CARB toroidal roller bearings

Table 3

Radial internal clearance of CARB bearings with a cylindrical bore

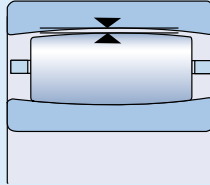

Bore diameter d		Radial internal clearance									
over	incl.	C2		Normal		C3		C4		C5	
		min.	max.	min.	max.	min.	max.	min.	max.	min.	max.
mm		µm									
18	24	15	30	25	40	35	55	50	65	65	85
24	30	15	35	30	50	45	60	60	80	75	95
30	40	20	40	35	55	55	75	70	95	90	120
40	50	25	45	45	65	65	85	85	110	105	140
50	65	30	55	50	80	75	105	100	140	135	175
65	80	40	70	65	100	95	125	120	165	160	210
80	100	50	85	80	120	120	160	155	210	205	260
100	120	60	100	100	145	140	190	185	245	240	310
120	140	75	120	115	170	165	215	215	280	280	350
140	160	85	140	135	195	195	250	250	325	320	400
160	180	95	155	150	220	215	280	280	365	360	450
180	200	105	175	170	240	235	310	305	395	390	495
200	225	115	190	185	265	260	340	335	435	430	545
225	250	125	205	200	285	280	370	365	480	475	605
250	280	135	225	220	310	305	410	405	520	515	655
280	315	150	240	235	330	330	435	430	570	570	715
315	355	160	260	255	360	360	485	480	620	620	790
355	400	175	280	280	395	395	530	525	675	675	850
400	450	190	310	305	435	435	580	575	745	745	930
450	500	205	335	335	475	475	635	630	815	810	1015
500	560	220	360	360	520	510	690	680	890	890	1110
560	630	240	400	390	570	560	760	750	980	970	1220
630	710	260	440	430	620	610	840	830	1080	1070	1340
710	800	300	500	490	680	680	920	920	1200	1200	1480
800	900	320	540	530	760	750	1020	1010	1330	1320	1660
900	1000	370	600	590	830	830	1120	1120	1460	1460	1830
1000	1120	410	660	660	930	930	1260	1260	1640	1640	2040
1120	1250	450	720	720	1020	1020	1380	1380	1800	1800	2240
1250	1400	490	800	800	1130	1130	1510	1510	1970	1970	2460
1400	1600	570	890	890	1250	1250	1680	1680	2200	2200	2740
1600	1800	650	1010	1010	1390	1390	1870	1870	2430	2430	3000

Table 4

Radial internal clearance of CARB bearings with a tapered bore

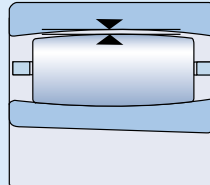

Bore diameter d		Radial internal clearance									
over	incl.	C2		Normal		C3		C4		C5	
		min.	max.	min.	max.	min.	max.	min.	max.	min.	max.
mm		µm									
18	24	15	35	30	45	40	55	55	70	65	85
24	30	20	40	35	55	50	65	65	85	80	100
30	40	25	50	45	65	60	80	80	100	100	125
40	50	30	55	50	75	70	95	90	120	115	145
50	65	40	65	60	90	85	115	110	150	145	185
65	80	50	80	75	110	105	140	135	180	175	220
80	100	60	100	95	135	130	175	170	220	215	275
100	120	75	115	115	155	155	205	200	255	255	325
120	140	90	135	135	180	180	235	230	295	290	365
140	160	100	155	155	215	210	270	265	340	335	415
160	180	115	175	170	240	235	305	300	385	380	470
180	200	130	195	190	260	260	330	325	420	415	520
200	225	140	215	210	290	285	365	360	460	460	575
225	250	160	235	235	315	315	405	400	515	510	635
250	280	170	260	255	345	340	445	440	560	555	695
280	315	195	285	280	380	375	485	480	620	615	765
315	355	220	320	315	420	415	545	540	680	675	850
355	400	250	350	350	475	470	600	595	755	755	920
400	450	280	385	380	525	525	655	650	835	835	1005
450	500	305	435	435	575	575	735	730	915	910	1115
500	560	330	480	470	640	630	810	800	1010	1000	1230
560	630	380	530	530	710	700	890	880	1110	1110	1350
630	710	420	590	590	780	770	990	980	1230	1230	1490
710	800	480	680	670	860	860	1100	1100	1380	1380	1660
800	900	520	740	730	960	950	1220	1210	1530	1520	1860
900	1000	580	820	810	1040	1040	1340	1340	1670	1670	2050
1000	1120	640	900	890	1170	1160	1500	1490	1880	1870	2280
1120	1250	700	980	970	1280	1270	1640	1630	2060	2050	2500
1250	1400	770	1080	1080	1410	1410	1790	1780	2250	2250	2740
1400	1600	870	1200	1200	1550	1550	1990	1990	2500	2500	3050
1600	1800	950	1320	1320	1690	1690	2180	2180	2730	2730	3310

9 CARB toroidal roller bearings

Axial displacement

CARB toroidal roller bearings can accommodate axial displacement of the shaft relative to the housing within the bearing. The permissible axial displacement from the normal position of one bearing ring relative to the other is limited by two criteria:

- **Displacement of the roller set**
Misalignment as well as axial displacement influences the axial position of the rollers in a CARB bearing (→ **fig. 7**). The rollers should not protrude from the side face of a bearing ring (→ **fig. 8**) or make contact with a retaining ring (→ **fig. 9**) or seal. To accommodate the displacement of the roller and cage assembly, free space must be provided on both sides of the bearing (→ *Free space on both sides of the bearing*, page 974).
- **Sufficient radial internal clearance**
CARB bearings should always operate with radial internal clearance. The axial position of the rollers influences the radial internal clearance. The typical clearance window for a CARB bearing is illustrated in **diagram 1**. The diagram also illustrates calculation examples 2 and 3 (→ **page 970**).

The permissible axial displacement is obtained from the smaller of these two limitations.

Fig. 7

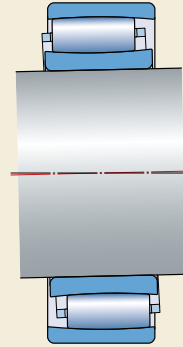

Fig. 8

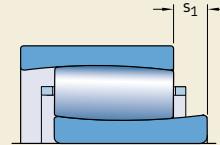

Fig. 9

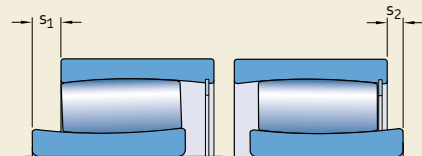
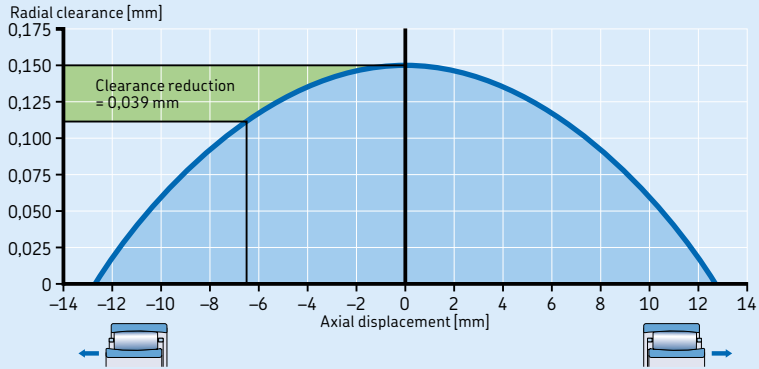

Diagram 1

The clearance window for a C 3052 CARB bearing with a maximum operating clearance of 0,150 mm



Calculating the permissible axial displacement

Limited by the displacement of the roller set

When the bearing rings are not misaligned, the axial displacement is limited by the values s_1 or s_2 (→ **figs. 8 and 9, page 968**).

When the bearing rings are misaligned, the axial displacement values s_1 or s_2 must be reduced:

$$s_{rol} = s_1 - k_1 B \alpha \quad \text{or} \quad s_{rol} = s_2 - k_1 B \alpha$$

Calculation example 1

What is the maximum axial displacement the roller set permits for a C 3052 bearing when the bearing rings are misaligned by $\alpha = 0,3^\circ$?

$$s_{rol} = s_1 - k_1 B \alpha$$

$$s_{rol} = 19,3 - 0,122 \times 104 \times 0,3 = 15,5 \text{ mm}$$

Limited by the reduction of internal clearance

The axial displacement for a maximum clearance reduction can be estimated using:

$$s_{cle} = \sqrt{\frac{B C_{red}}{k_2}}$$

The clearance reduction caused by a certain axial displacement can be estimated using:

$$C_{red} = \frac{k_2 s_{cle}^2}{B}$$

Calculation example 2

What is the maximum axial displacement for a C 3052 bearing if a maximum internal clearance reduction of 0,15 mm is permitted?

$$s_{cle} = \sqrt{\frac{B C_{red}}{k_2}}$$

$$s_{cle} = \sqrt{\frac{104 \times 0,15}{0,096}} = 12,7 \text{ mm}$$

See also **diagram 1** (→ **page 969**).

Calculation example 3

What internal clearance reduction does an axial displacement from the central position of 6,5 mm cause in a C 3052 bearing?

$$C_{red} = \frac{k_2 s_{cle}^2}{B}$$

$$C_{red} = \frac{0,096 \times 6,5^2}{104} = 0,039 \text{ mm}$$

See also **diagram 1** (→ **page 969**).

Symbols

B	= bearing width [mm]
C_{red}	= reduction of radial clearance as a result of an axial displacement from a centred position [mm]
k_1	= misalignment factor (→ product tables)
k_2	= operating clearance factor (→ product tables)
s_1	= axial displacement limit in bearings with a cage or in full complement bearings when displacing away from the retaining ring [mm] (→ product tables)
s_2	= axial displacement limit in sealed and full complement bearings when displacing toward the seal or retaining ring respectively [mm] (→ product tables)
s_{cle}	= maximum axial displacement from a centred position, corresponding to a certain radial clearance reduction [mm]
s_{rol}	= maximum axial displacement limited by the roller set, including misalignment effect [mm]
α	= misalignment [°]

Bearing data for calculation examples

Bearing C 3052

$B = 104$ mm

$s_1 = 19,3$ mm

$k_1 = 0,122$

$k_2 = 0,096$

Offset mounting

Bearing rings are usually mounted so that they are not displaced relative to each other. However, if considerable thermal changes in shaft length can be expected, the inner ring can be mounted offset, relative to the outer ring, up to the axial displacement limit s_1 or s_2 (→ **fig. 9, page 968**) in the direction opposite to the expected shaft elongation (→ **fig. 10**) or contraction. Offsetting one ring relative to the other, extends the permissible axial displacement. This advantage is used, for example, in the bearing arrangements of drying cylinders in paper machines.

Fig. 10

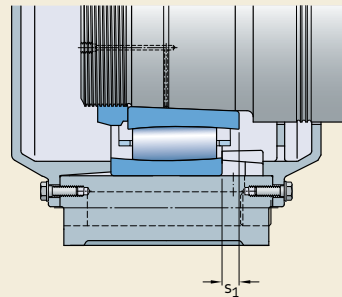

Loads

	CARB bearings with a cage	Full complement CARB bearings
Minimum load	$F_{rm} = 0,007 C_0$ Oil lubricated bearings: $n/n_r \leq 0,3 \rightarrow F_{rm} = 0,002 C_0$ $0,3 < n/n_r \leq 2 \rightarrow F_{rm} = 0,002 C_0 \left(1 + 2 \sqrt{\frac{n}{n_r} - 0,3} \right)$	$F_{rm} = 0,01 C_0$
For additional information (→ page 86)	When starting up at low temperatures or when the lubricant is highly viscous, even greater minimum loads than $F_{rm} = 0,007 C_0$ and $0,01 C_0$, respectively, may be required. The weight of the components supported by the bearing, together with external forces, generally exceed the requisite minimum load. If this is not the case, the bearing must be subjected to an additional radial load.	
Equivalent dynamic bearing load	$P = F_r$	
For additional information (→ page 85)		
Equivalent static bearing load	$P_0 = F_r$	
For additional information (→ page 88)		
Symbols	C_0 = basic static load rating [kN] (→ product tables) F_r = radial load [kN] F_{rm} = minimum radial load [kN] P = equivalent dynamic bearing load [kN] P_0 = equivalent static bearing load [kN] n = rotational speed [r/min] n_r = reference speed [r/min] (→ product tables)	

Temperature limits

The permissible operating temperature for CARB bearings can be limited by:

- the dimensional stability of the bearing rings
- the cage
- the seals
- the lubricant

When temperatures outside the permissible range are expected, contact the SKF application engineering service.

Bearing rings

CARB bearings undergo a special heat treatment. The bearings are heat stabilized for use at temperatures up to 200 °C (390 °F) for at least 2 500 h, or for brief periods at even higher temperatures.

Cages

Steel or brass cages can be used at the same operating temperatures as the bearing rings. For temperature limits of polymer cages, refer to *Cage materials* (→ **page 152**).

Seals

The permissible operating temperature for HNBR seals is –40 to +150 °C (–40 to +300 °F).

Lubricants

Temperature limits for the grease used in sealed CARB toroidal roller bearings are provided in **table 1** (→ **page 962**). Temperature limits for other SKF greases are provided under *Lubrication* (→ **page 239**).

When using lubricants not supplied by SKF, the temperature limits should be evaluated according to the SKF traffic light concept (→ **page 244**).

Permissible speed

The permissible speed can be estimated using the speed ratings listed in the product tables and applying the information provided under *Speeds* (→ **page 117**). If no reference speed is listed in the product tables, the limiting speed is the permissible speed.

Design of bearing arrangements

Free space on both sides of the bearing

To enable axial displacement of the shaft relative to the housing, free space must be provided on both sides of the bearing as indicated in **fig. 11**. The value for the width of this free space is based on:

- the value C_a (→ **product tables**)
- the expected axial displacement of the bearing rings from the central position during operation
- the displacement of the rings caused by misalignment

For additional information, refer to *Axial displacement* (→ **page 968**).

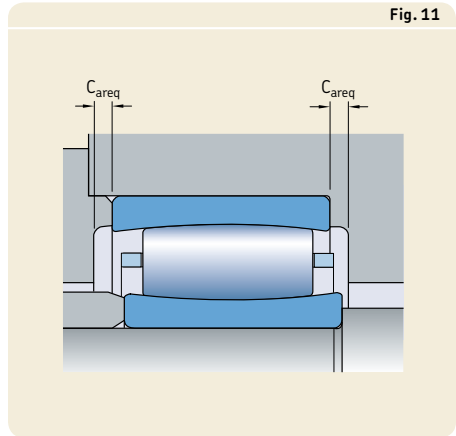

Calculating the free space required on both sides of the bearing

	Symbols
$C_{areq} = C_a + 0,5 (s + k_1 B \alpha)$	<p>B = bearing width [mm]</p> <p>C_a = minimum width of space required on both sides of the bearing [mm] (→ product tables)</p> <p>C_{areq} = width of space required on both sides of the bearing [mm]</p> <p>k_1 = misalignment factor (→ product tables)</p> <p>s = relative axial displacement of rings, e.g. thermal shaft elongation [mm]</p> <p>α = misalignment [°]</p>

Fig. 12

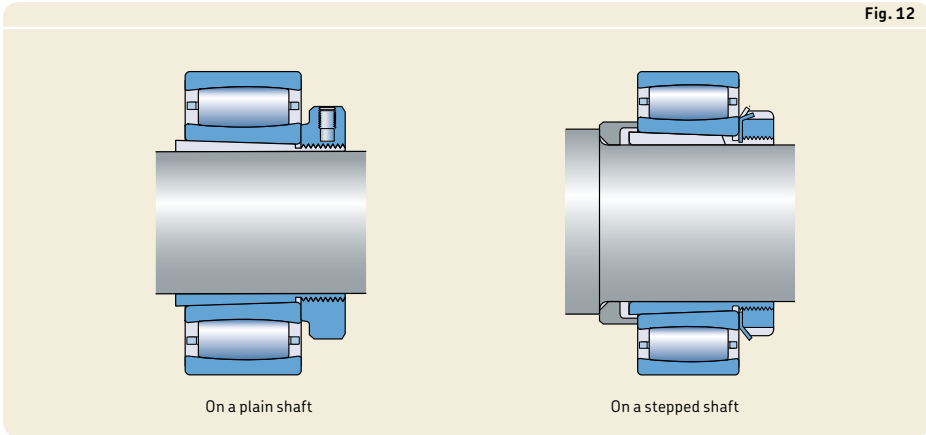

Bearings on sleeves

CARB bearings with a tapered bore can be mounted on plain or stepped shafts with an adapter sleeve (→ **fig. 12**) or on stepped shafts with a withdrawal sleeve (→ **fig. 13**). Adapter sleeves are supplied complete with a locking device. For additional information about sleeves, refer to *Bearing accessories* (→ **page 1269**).

When using CARB bearings on an adapter sleeve, appropriate SKF adapter sleeve assemblies must be used to prevent the locking device from interfering with the cage (→ **product tables, page 1000**). Check axial displacement carefully, as it could be that s_1 (→ **product tables, page 980**) cannot be fully realized.

Fig. 13

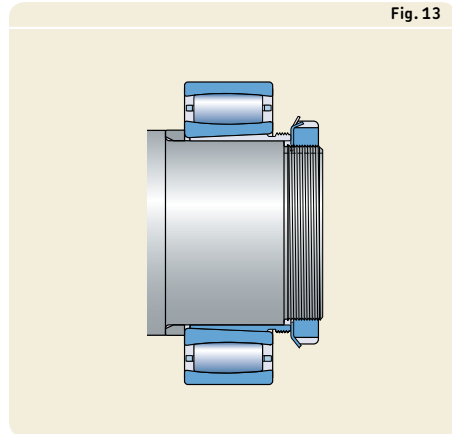

9 CARB toroidal roller bearings

Appropriate bearing housings

The combination of a CARB bearing, appropriate sleeve, where needed, and an appropriate SKF bearing housing provides a cost-effective, interchangeable and reliable solution for the non-locating bearing position that fulfils the demand for easy maintenance. SKF standard housings are available for almost all CARB bearings in the 0, 1, 2 and 3 diameter series.

Two arrangements are possible when using standard housings, without requiring special considerations:

- CARB bearings with a tapered bore on an adapter sleeve and a plain shaft
- CARB bearings with a cylindrical bore on a stepped shaft

Additional information about SKF bearing housings is available online at skf.com/housings.

Mounting

Due to the design of CARB toroidal roller bearings, the rings and roller complement may be displaced axially from their normal position during handling. Therefore, SKF recommends mounting CARB bearings when the shaft or housing is in the horizontal position. Also, whenever possible, rotate the inner or outer ring to align the rollers during mounting.

If CARB bearings are mounted when the shaft or housing is in the vertical position, the roller complement, together with the inner or outer ring will move downward until there is no more clearance. Then, when the bearing rings expand or contract as a result of an interference fit, a preload is likely to result. To prevent this preload condition from occurring, rotate the inner or outer ring during installation. If this is not feasible, use a bearing handling tool or other device to keep the bearing components arranged centrally.

Mounting bearings with a tapered bore

Bearings with a tapered bore are always mounted with an interference fit. To obtain the proper degree of interference, one of the following methods can be used:

- 1 measuring the clearance reduction
- 2 measuring the lock nut tightening angle
- 3 measuring the axial drive-up
- 4 applying the SKF Drive-up Method
- 5 measuring the inner ring expansion (SensorMount)

For additional information about these mounting methods, refer to *Mounting, dismounting and bearing care* (→ **page 271**), or the *SKF bearing maintenance handbook*.

For bearings with $d > 100$ mm, SKF recommends using the SKF Drive-up Method. This is a fast, reliable and safe method to achieve the appropriate interference fit. Additional information is available online at skf.com/drive-up.

Recommended values to apply methods 1 to 3 are listed in **table 5**.

Table 5

Drive-up data for CARB toroidal roller bearings with a tapered bore

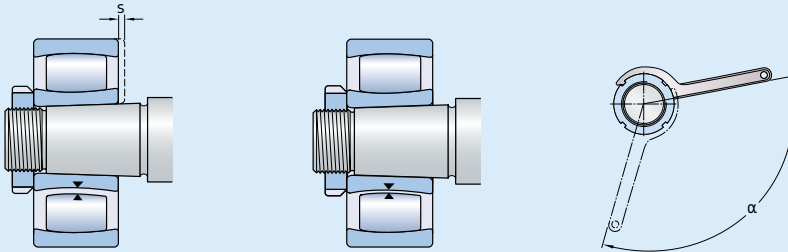

Bore diameter d		Reduction of radial internal clearance		Axial drive-up ^{1) 2)} s				Lock nut tightening angle ²⁾ α
over	incl.	min.	max.	Taper 1:12		Taper 1:30		Taper 1:12
mm	mm	mm	mm	min.	max.	min.	max.	°
24	30	0,010	0,015	0,25	0,29	–	–	100
30	40	0,015	0,020	0,30	0,35	0,75	0,90	115
40	50	0,020	0,025	0,37	0,44	0,95	1,10	130
50	65	0,025	0,035	0,45	0,54	1,15	1,35	115
65	80	0,035	0,040	0,55	0,65	1,40	1,65	130
80	100	0,040	0,050	0,66	0,79	1,65	2,00	150
100	120	0,050	0,060	0,79	0,95	2,00	2,35	
120	140	0,060	0,075	0,93	1,10	2,30	2,80	
140	160	0,070	0,085	1,05	1,30	2,65	3,20	
160	180	0,080	0,095	1,20	1,45	3,00	3,60	
180	200	0,090	0,105	1,30	1,60	3,30	4,00	
200	225	0,100	0,120	1,45	1,80	3,70	4,45	
225	250	0,110	0,130	1,60	1,95	4,00	4,85	
250	280	0,120	0,150	1,80	2,15	4,50	5,40	
280	315	0,135	0,165	2,00	2,40	4,95	6,00	
315	355	0,150	0,180	2,15	2,65	5,40	6,60	
355	400	0,170	0,210	2,50	3,00	6,20	7,60	
400	450	0,195	0,235	2,80	3,40	7,00	8,50	
450	500	0,215	0,265	3,10	3,80	7,80	9,50	
500	560	0,245	0,300	3,40	4,10	8,40	10,30	
560	630	0,275	0,340	3,80	4,65	9,50	11,60	
630	710	0,310	0,380	4,25	5,20	10,60	13,00	
710	800	0,350	0,425	4,75	5,80	11,90	14,50	
800	900	0,395	0,480	5,40	6,60	13,50	16,40	
900	1 000	0,440	0,535	6,00	7,30	15,00	18,30	
1 000	1 120	0,490	0,600	6,40	7,80	16,00	19,50	
1 120	1 250	0,550	0,670	7,10	8,70	17,80	21,70	
1 250	1 400	0,610	0,750	8,00	9,70	19,90	24,30	
1 400	1 600	0,700	0,850	9,10	11,10	22,70	27,70	
1 600	1 800	0,790	0,960	10,20	12,50	25,60	31,20	

NOTE: Applying the recommended values prevents the inner ring from creeping, but does not ensure correct radial internal clearance in operation. Additional influences from the bearing housing fit and temperature differences between the inner and outer rings must be considered carefully when selecting the bearing radial internal clearance class. For additional information, contact the SKF application engineering service.

Valid only for solid steel shafts and general applications.

¹⁾ Not valid for the SKF Drive-up Method.

²⁾ The listed values are to be used as guideline values only, as it is difficult to establish an exact starting position. Also, the axial drive-up s differs slightly between the different bearings series.

Designation system

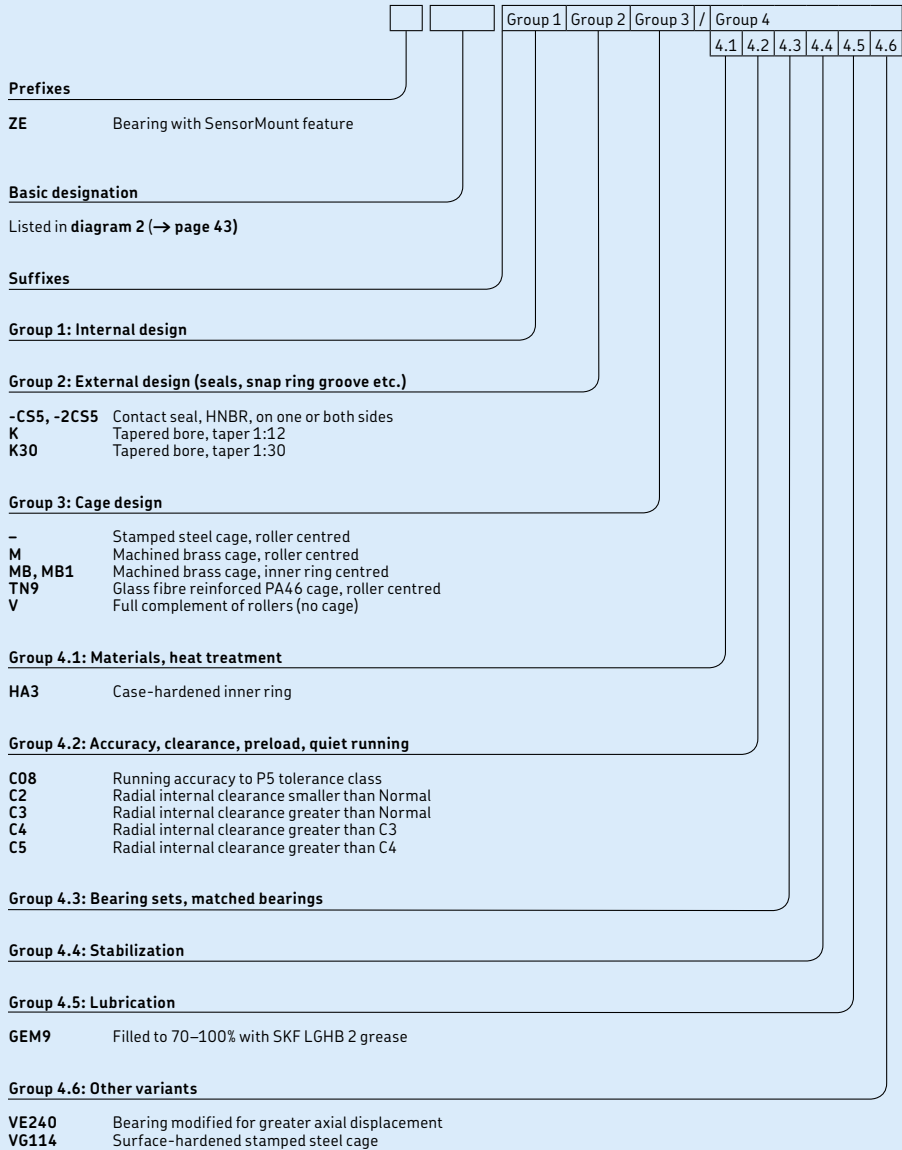

9.1 CARB toroidal roller bearings d 25 – 55 mm

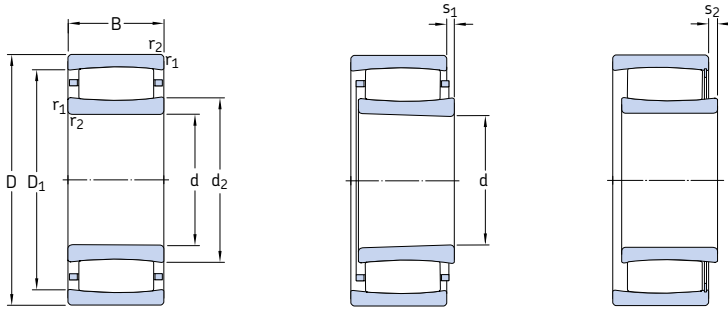

Cylindrical bore

Tapered bore

Full complement

Principal dimensions			Basic load ratings		Fatigue load limit P _u	Speed ratings		Mass	Designations	
d	D	B	dynamic C	static C ₀		Reference speed	Limiting speed		Bearing with cylindrical bore	tapered bore
mm			kN		kN	r/min		kg	–	
25	52	18	44	40	4,55	13 000	18 000	0,17	* C 2205 TN9 ¹⁾	* C 2205 KTN9 ¹⁾
	52	18	50	49	5,7	–	7 000	0,18	* C 2205 V ¹⁾	* C 2205 KV ¹⁾
30	55	45	134	180	21,2	–	3 200	0,49	* C 6006 V	–
	62	20	69,5	62	7,2	11 000	15 000	0,28	* C 2206 TN9	* C 2206 KTN9
	62	20	76,5	71	8,3	–	6 000	0,29	* C 2206 V	* C 2206 KV
35	72	23	83	80	9,3	9 500	13 000	0,44	* C 2207 TN9	* C 2207 KTN9
	72	23	95	96	11,2	–	5 300	0,46	* C 2207 V	* C 2207 KV
40	62	22	76,5	100	11,8	–	4 300	0,25	* C 4908 V	* C 4908 K30V
	62	30	104	143	16	–	3 400	0,35	* C 5908 V ¹⁾	–
	62	40	122	180	21,2	–	2 800	0,45	* C 6908 V ¹⁾	–
	80	23	90	86,5	10,2	8 000	11 000	0,51	* C 2208 TN9	* C 2208 KTN9
45	80	23	102	104	12,2	–	4 500	0,53	* C 2208 V	* C 2208 KV
	68	22	81,5	112	13,2	–	3 800	0,29	* C 4909 V ¹⁾	* C 4909 K30V ¹⁾
	68	30	110	163	18,3	–	3 200	0,41	* C 5909 V ¹⁾	–
	68	40	132	200	23,6	–	2 600	0,53	* C 6909 V ¹⁾	–
	85	23	93	93	10,8	7 500	11 000	0,56	* C 2209 TN9	* C 2209 KTN9
50	85	23	106	110	12,9	–	4 300	0,58	* C 2209 V	* C 2209 KV
	72	22	86,5	125	14,6	–	3 600	0,29	* C 4910 V	* C 4910 K30V
	72	30	114	176	20,8	–	2 800	0,41	* C 5910 V ¹⁾	–
	72	40	140	224	26	–	2 400	0,54	* C 6910 V	–
	80	30	116	140	16,3	5 600	7 500	0,55	* C 4010 TN9	* C 4010 K30TN9
	80	30	137	176	20,8	–	3 000	0,58	* C 4010 V ¹⁾	* C 4010 K30V ¹⁾
55	90	23	98	100	11,8	7 000	9 500	0,6	* C 2210 TN9	* C 2210 KTN9
	90	23	114	122	14,3	–	3 800	0,63	* C 2210 V	* C 2210 KV
	80	25	106	153	17,6	–	3 200	0,42	* C 4911 V ¹⁾	* C 4911 K30V ¹⁾
	80	34	143	224	25	–	2 600	0,6	* C 5911 V ¹⁾	–
	80	45	180	300	35,5	–	2 200	0,78	* C 6911 V ¹⁾	–
100	25	116	114	13,4	6 300	9 000	0,8	* C 2211 TN9	* C 2211 KTN9	
100	25	132	134	15,6	–	3 400	0,82	* C 2211 V	* C 2211 KV	

¹⁾ Check availability prior to incorporating in a bearing arrangement design.

* SKF Explorer bearing

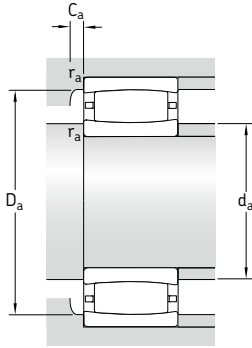

Dimensions					Abutment and fillet dimensions					Calculation factors				
d	d ₂	D ₁	r _{1,2} min.	s ₁ ¹⁾	s ₂ ¹⁾	d _a min.	d _a max.	D _a min.	D _a max.	C _a ²⁾	r _a	k ₁	k ₂	
mm						mm				-				
25	33,2	43,8	1	5,8	-	30,6	32	42	46,4	0,3	1	0,09	0,126	
	33,2	43,8	1	5,8	2,8	30,6	40	-	46,4	-	1	0,09	0,135	
30	38,5	47,3	1	7,9	4,9	34,6	43	-	50,4	-	1	0,102	0,096	
	37,4	53,1	1	4,5	-	35,6	37,4	50,6	56,4	0,3	1	0,101	0,111	
	37,4	53,1	1	4,5	1,5	35,6	49	-	56,4	-	1	0,101	0,111	
35	44,8	60,7	1,1	5,7	-	42	44,8	58,5	65	0,1	1	0,094	0,121	
	44,8	60,7	1,1	5,7	2,7	42	57	-	65	-	1	0,094	0,121	
40	46,1	55,3	0,6	4,7	1,7	43,2	52	-	58,8	-	0,6	0,099	0,114	
	45,8	54,6	0,6	5	2	43,2	45	-	58,8	-	0,6	0,096	0,106	
	46,4	54	0,6	9,4	6,4	43,2	50	-	58,8	-	0,6	0,09	0,113	
	52,4	69,9	1,1	7,1	-	47	52,4	67,1	73	0,3	1	0,093	0,128	
	52,4	69,9	1,1	7,1	4,1	47	66	-	73	-	1	0,093	0,128	
45	51,5	60,7	0,6	4,7	1,7	48,2	57	-	64,8	-	0,6	0,102	0,114	
	51,3	60,1	0,6	5	2	48,2	51	-	64,8	-	0,6	0,096	0,108	
	52	59,5	0,6	9,4	6,4	48,2	55	-	64,8	-	0,6	0,091	0,113	
	55,6	73,1	1,1	7,1	-	52	55,6	70,4	78	0,3	1	0,095	0,128	
	55,6	73,1	1,1	7,1	4,1	52	69	-	78	-	1	0,095	0,128	
50	56,9	66,1	0,6	4,7	1,7	53,2	62	-	68,8	-	0,6	0,103	0,114	
	56,9	65,7	0,6	6	3	53,2	62	-	68,8	-	0,6	0,103	0,106	
	57,5	65	0,6	9,4	6,4	53,2	61	-	68,8	-	0,6	0,093	0,113	
	57,6	70,8	1	6	-	54,6	57,6	69,7	75,4	0,1	1	0,103	0,107	
	57,6	70,8	1	6	3	54,6	67	-	75,4	-	1	0,103	0,107	
	61,9	79,4	1,1	7,1	-	57	61,9	76,7	83	-0,8 ³⁾	1	0,097	0,128	
	61,9	79,4	1,1	7,1	3,9	57	73	-	83	-	1	0,097	0,128	
	61,9	79,4	1,1	7,1	3,9	57	73	-	83	-	1	0,097	0,128	
55	61,9	72,3	1,5	5,5	2,5	64	68	-	71	-	1,5	0,107	0,107	
	62,8	72,8	1	6	3	59,6	63	-	80,4	-	1	0,097	0,109	
	62,7	71,5	1	7,9	4,9	59,6	67	-	75,4	-	1	0,107	0,096	
	65,8	86,7	1,5	8,6	-	64	65,8	83,1	91	0,3	1,5	0,094	0,133	
	65,8	86,7	1,5	8,6	5,4	64	80	-	91	-	1,5	0,094	0,133	
	65,8	86,7	1,5	8,6	5,4	64	80	-	91	-	1,5	0,094	0,133	

¹⁾ Permissible axial displacement from the normal position of one bearing ring relative to the other (→ page 968).

²⁾ Minimum width of free space for bearings with cage where the rings are aligned. For required free space when a ring is displaced → page 974.

³⁾ To be used only when calculating the required free space (→ page 974).

9.1 CARB toroidal roller bearings d 60 – 80 mm

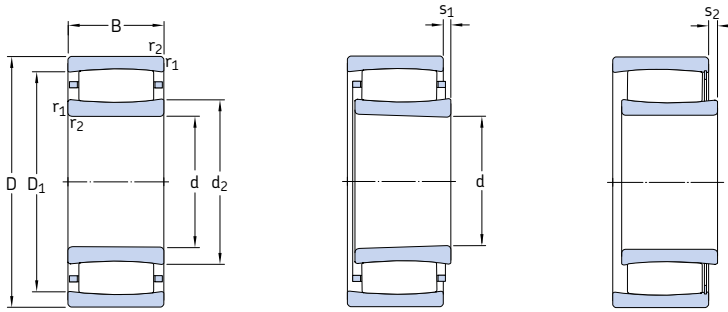

Cylindrical bore

Tapered bore

Full complement

Principal dimensions			Basic load ratings		Fatigue load limit P_u	Speed ratings		Mass	Designations	
d	D	B	dynamic C	static C_0		Reference speed	Limiting speed		Bearing with cylindrical bore	tapered bore
mm			kN		kN	r/min		kg	–	
60	85	25	112	170	19,6	–	3 000	0,46	* C 4912 V ¹⁾	* C 4912 K30V ¹⁾
	85	34	150	240	26,5	–	2 400	0,64	* C 5912 V ¹⁾	–
	110	28	143	156	18,3	5 600	7 500	1,1	* C 2212 TN9	* C 2212 KTN9
	110	28	166	190	22,4	–	2 800	1,15	* C 2212 V	* C 2212 KV
65	90	25	116	180	20,8	–	2 800	0,5	* C 4913 V ¹⁾	* C 4913 K30V ¹⁾
	90	34	156	260	30,5	–	2 200	0,68	* C 5913 V ¹⁾	–
	90	45	196	355	41,5	–	1 800	0,9	* C 6913 V ¹⁾	–
	100	35	193	300	33,5	–	2 400	1,05	* C 4013 V ¹⁾	* C 4013 K30V ¹⁾
	120	31	180	180	21,2	5 300	7 500	1,45	* C 2213 TN9	* C 2213 KTN9
	120	31	204	216	25,5	–	2 400	1,5	* C 2213 V	* C 2213 KV
70	100	30	163	163	28	–	2 600	0,78	* C 4914 V ¹⁾	* C 4914 K30V ¹⁾
	100	40	196	310	36,5	–	2 000	1	* C 5914 V ¹⁾	–
	100	54	265	455	49	–	1 700	1,4	* C 6914 V ¹⁾	–
	125	31	186	196	22,8	5 000	7 000	1,5	* C 2214 TN9	* C 2214 KTN9
	125	31	212	228	26,5	–	2 400	1,55	* C 2214 V	* C 2214 KV
	150	51	405	430	49	3 800	5 000	4,3	* C 2314	* C 2314 K
75	105	30	166	255	30	–	2 400	0,82	* C 4915 V ¹⁾	* C 4915 K30V ¹⁾
	105	40	204	325	38	–	1 900	1,1	* C 5915 V	–
	105	54	204	325	37,5	–	1 900	1,4	* C 6915 V/VE240	–
	115	40	208	345	40,5	–	2 000	1,6	* C 4015 V	* C 4015 K30V
	130	31	196	208	24	4 800	6 700	1,6	* C 2215	* C 2215 K
	130	31	220	240	28	–	2 200	1,65	* C 2215 V	* C 2215 KV
80	160	55	425	465	52	3 600	4 800	5,3	* C 2315	* C 2315 K
	110	30	173	275	32	–	2 200	0,86	* C 4916 V ¹⁾	* C 4916 K30V ¹⁾
	110	40	208	345	40,5	–	1 800	1,15	* C 5916 V ¹⁾	–
	140	33	220	250	28,5	4 300	6 000	2,05	* C 2216	* C 2216 K
	140	33	255	305	34,5	–	2 000	2,15	* C 2216 V	* C 2216 KV
170	58	510	550	60	3 400	4 500	6,3	* C 2316	* C 2316 K	

¹⁾ Check availability prior to incorporating in a bearing arrangement design.

* SKF Explorer bearing

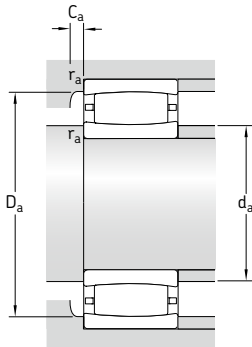

Dimensions					Abutment and fillet dimensions					Calculation factors				
d	d ₂	D ₁	r _{1,2} min.	s ₁ ¹⁾	s ₂ ¹⁾	d _a min.	d _a max.	D _a min.	D _a max.	C _a ²⁾	r _a	k ₁	k ₂	
mm														
60	68	78,2	1	5,5	2,3	64,6	72	-	80,4	-	1	0,107	0,108	
	66,8	76,5	1	6	2,8	64,6	62	-	80,4	-	1	0,097	0,11	
	77,1	97,9	1,5	8,5	-	69	77,1	94,7	101	0,3	1,5	0,1	0,123	
	77,1	97,9	1,5	8,5	5,3	69	91	-	101	-	1,5	0,1	0,123	
65	72,1	82,2	1	5,5	2,3	69,6	72	-	85,4	-	1	0,107	0,109	
	72,8	82,7	1	6	2,8	69,6	76	-	85,4	-	1	0,113	0,097	
	72,8	81,5	1	7,9	4,7	69,6	76	-	85,4	-	1	0,109	0,096	
	75,5	88,4	1,1	4,4	1,2	71	81	-	94	-	1	0,11	0,1	
	79	106	1,5	9,6	-	74	79	102	111	0,2	1,5	0,097	0,127	
	79	106	1,5	9,6	5,3	74	97	-	111	-	1,5	0,097	0,127	
70	78	91	1	6	2,8	74,6	78	-	95,4	-	1	0,107	0,107	
	78,5	90,5	1	9,4	6,2	74,6	84	-	95,4	-	1	0,097	0,114	
	79,1	89,8	1	9	5,8	74,6	75	-	95,4	-	1	0,102	0,1	
	83,7	111	1,5	9,6	-	79	83,7	107	116	0,4	1,5	0,098	0,127	
	83,7	111	1,5	9,6	5,3	79	102	-	116	-	1,5	0,098	0,127	
	91,4	130	2,1	9,1	-	82	106	119	138	2,2	2	0,11	0,099	
75	83,1	96,1	1	6	2,8	79,6	83	-	100	-	1	0,107	0,108	
	83,6	95,5	1	9,4	6,2	79,6	89	-	100	-	1	0,098	0,114	
	83,6	95,5	1	9,2	9,2	79,6	88	-	100	-	1	0,073	0,154	
	88,7	101	1,1	9,4	5,1	81	94	-	109	-	1	0,099	0,114	
	88,5	116	1,5	9,6	-	84	98,3	106	121	1,2	1,5	0,099	0,127	
	88,5	116	1,5	9,6	5,3	84	107	-	121	-	1,5	0,099	0,127	
	98,5	137	2,1	13,1	-	87	113	126	148	2,2	2	0,103	0,107	
	98,5	137	2,1	13,1	-	87	113	126	148	2,2	2	0,103	0,107	
80	88,1	102	1	6	1,7	84,6	94	-	105	-	1	0,112	0,107	
	88,7	101	1	9,4	5,1	84,6	94	-	105	-	1	0,099	0,114	
	98,1	125	2	9,1	-	91	107	116	129	1,2	2	0,104	0,121	
	98,1	125	2	9,1	4,8	91	116	-	129	-	2	0,104	0,121	
	102	146	2,1	10,1	-	92	119	133	158	2,4	2	0,107	0,101	
	102	146	2,1	10,1	-	92	119	133	158	2,4	2	0,107	0,101	

¹⁾ Permissible axial displacement from the normal position of one bearing ring relative to the other (→ page 968).

²⁾ Minimum width of free space for bearings with cage where the rings are aligned. For required free space when a ring is displaced → page 974.

9.1 CARB toroidal roller bearings d 85 – 110 mm

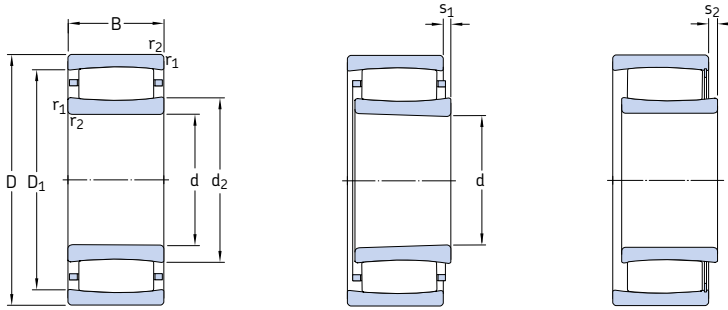

Cylindrical bore

Tapered bore

Full complement

Principal dimensions			Basic load ratings		Fatigue load limit	Speed ratings		Mass	Designations	
d	D	B	dynamic C	static C ₀	P _u	Refer- ence speed	Limiting speed	kg	Bearing with cylindrical bore	tapered bore
mm			kN		kN	r/min		kg	-	
85	120	35	224	355	40,5	-	2 000	1,3	* C 4917 V ¹⁾	* C 4917 K30V ¹⁾
	120	46	275	465	52	-	1 700	1,7	* C 5917 V ¹⁾	-
	150	36	275	320	35,5	4 000	5 600	2,65	* C 2217	* C 2217 K
	150	36	315	390	43	-	1 800	2,8	* C 2217 V	* C 2217 KV
	180	60	540	600	64	3 200	4 300	7,4	* C 2317	* C 2317 K
90	125	35	186	315	35,5	-	2 000	1,3	* C 4918 V ¹⁾	* C 4918 K30V ¹⁾
	125	46	193	325	37,5	2 600	4 000	1,75	* C 5918 MB	-
	125	46	224	400	45,5	-	1 600	1,75	* C 5918 V	-
	150	72	455	670	75	-	1 100	5,1	* BSC-2039 V	-
	160	40	325	380	41,5	3 800	5 300	3,3	* C 2218	* C 2218 K
	160	40	365	440	48	-	1 600	3,45	* C 2218 V ¹⁾	* C 2218 KV ¹⁾
	190	64	610	695	73,5	2 800	4 000	8,65	* C 2318	* C 2318 K
95	170	43	325	380	41,5	3 800	5 300	4,1	* C 2219 ¹⁾	* C 2219 K ¹⁾
	200	67	610	695	73,5	2 800	4 000	10	* C 2319	* C 2319 K
100	140	40	240	455	50	-	1 800	2,05	* C 4920 V ¹⁾	* C 4920 K30V ¹⁾
	140	54	375	640	68	-	1 400	2,7	* C 5920 V ¹⁾	-
	150	50	355	530	58,5	-	1 400	3,05	* C 4020 V	* C 4020 K30V
	150	67	510	865	95	-	1 100	4,3	* C 5020 V	-
	165	52	475	655	71	-	1 300	4,45	* C 3120 V	* C 3120 KV
110	170	65	475	655	71	-	1 300	5,3	* C 4120 V/VE240 ¹⁾	* C 4120 K30V/VE240 ¹⁾
	170	65	475	655	71	-	1 000	5,95	* BSC-2034 V	-
	180	46	415	465	49	3 600	4 800	4,95	* C 2220	* C 2220 K
	215	73	800	880	90	2 600	3 600	12,5	* C 2320	* C 2320 K
	170	45	355	480	51	3 200	4 500	3,6	* C 3022 ¹⁾	* C 3022 K ¹⁾
170	60	430	655	69,5	2 600	3 400	5,3	* C 4022 MB	* C 4022 K30MB	
170	60	500	800	85	-	1 200	5,2	* C 4022 V	* C 4022 K30V	
180	69	670	1 000	104	-	900	7,1	* C 4122 V	* C 4122 K30V	
200	53	530	620	64	3 200	4 300	7	* C 2222	* C 2222 K	

¹⁾ Check availability prior to incorporating in a bearing arrangement design.

* SKF Explorer bearing

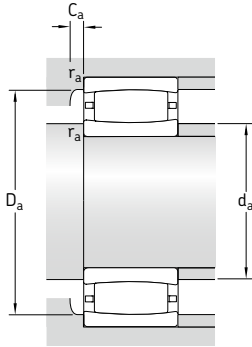

Dimensions						Abutment and fillet dimensions						Calculation factors	
d	d ₂	D ₁	r _{1,2} min.	s ₁ ¹⁾	s ₂ ¹⁾	d _a min.	d _a max.	D _a min.	D _a max.	C _a ²⁾	r _a	k ₁	k ₂
mm						mm						-	
85	94,5	109	1,1	6	1,7	91	94	-	114	-	1	0,1	0,114
	95	109	1,1	8,9	4,6	91	91	-	114	-	1	0,098	0,109
	103	133	2	7,1	-	96	114	123	139	1,3	2	0,114	0,105
	103	133	2	7,1	1,7	96	120	-	139	-	2	0,114	0,105
	110	153	3	12,1	-	99	126	141	166	2,4	2,5	0,105	0,105
90	102	113	1,1	11	6,7	96	100	-	119	-	1	0,125	0,098
	100	113	1,1	2,9	-	96	99	113	119	-0,9 ³⁾	1	0	0,131
	102	113	1,1	15,4	11,1	96	106	-	119	-	1	0,089	0,131
	109	131	2	19,7	19,7	101	121	-	139	-	2	0,087	0,123
	111	144	2	9,5	-	101	124	133	149	1,4	2	0,104	0,117
	111	144	2	9,5	4,1	101	131	-	149	-	2	0,104	0,117
	119	166	3	9,6	-	104	138	154	176	2	2,5	0,108	0,101
95	112	144	2,1	12,4	-	107	124	133	158	0	2	0,097	0,126
	119	166	3	12,6	-	109	138	154	186	2,1	2,5	0,103	0,106
100	114	126	1,1	9,4	5,1	106	118	-	134	-	1	0,105	0,114
	110	127	1,1	9	4,7	106	107	-	134	-	1	0,103	0,105
	113	135	1,5	14	9,7	107	126	-	143	-	1,5	0,098	0,118
	114	136	1,5	9,3	5	107	127	-	143	-	1,5	0,112	0,094
	119	150	2	10,1	4,7	111	136	-	154	-	2	0,1	0,112
	120	148	2	17,7	17,7	111	135	-	154	-	2	0,09	0,125
	120	148	2	17,7	17,7	111	135	-	159	-	2	0,09	0,125
	118	157	2,1	10,1	-	112	134	146	168	0,9	2	0,108	0,11
126	185	3	11	-	114	150	168	201	3,2	2,5	0,113	0,096	
110	128	156	2	9,5	-	120	138	149	160	0,9	2	0,112	0,107
	126	150	2	4,8	-	120	125	146	160	1,3	2	0	0,103
	126	150	2	12	6,6	120	136	-	160	-	2	0,107	0,103
	132	163	2	11,4	4,6	121	149	-	169	-	2	0,111	0,097
	132	176	2,1	11,1	-	122	150	161	188	1,9	2	0,113	0,103

¹⁾ Permissible axial displacement from the normal position of one bearing ring relative to the other (→ page 968).

²⁾ Minimum width of free space for bearings with cage where the rings are aligned. For required free space when a ring is displaced → page 974.

³⁾ To be used only when calculating the required free space (→ page 974).

9.1 CARB toroidal roller bearings d 120 – 160 mm

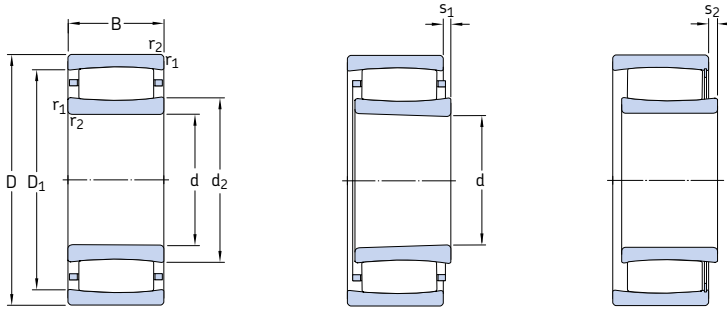

Cylindrical bore

Tapered bore

Full complement

Principal dimensions			Basic load ratings		Fatigue load limit P _u	Speed ratings		Mass	Designations	
d	D	B	dynamic C	static C ₀		Reference speed	Limiting speed		Bearing with cylindrical bore	tapered bore
mm			kN	kN		r/min		kg	–	
120	180	46	375	530	55	3 000	4 300	3,95	* C 3024 ¹⁾	* C 3024 K ¹⁾
	180	46	430	640	65,5	–	1 400	4,1	* C 3024 V	* C 3024 KV
	180	60	530	880	91,5	–	1 100	5,55	* C 4024 V	* C 4024 K30V
	180	60	430	640	65,5	–	1 400	5,05	* C 4024 V/VE240	* C 4024 K30V/VE240
	200	80	780	1 120	114	–	750	10	* C 4124 V ¹⁾	* C 4124 K30V ¹⁾
	215	58	610	710	71	2 800	4 000	8,65	* C 2224 ¹⁾	* C 2224 K ¹⁾
	215	76	750	980	98	2 400	3 200	12	* C 3224	* C 3224 K
130	200	52	390	585	58,5	2 800	3 800	5,9	* C 3026 ¹⁾	* C 3026 K ¹⁾
	200	69	620	930	93	2 200	2 800	7,85	* C 4026	* C 4026 K30
	200	69	720	1 120	112	–	850	8,15	* C 4026 V	* C 4026 K30V
	210	80	750	1 100	110	–	850	10,5	* C 4126 V/VE240	* C 4126 K30V/VE240
	230	64	735	930	91,5	2 800	3 800	11,5	* C 2226	* C 2226 K
140	210	53	490	735	72	2 600	3 400	6,3	* C 3028 ¹⁾	* C 3028 K ¹⁾
	210	69	750	1 220	120	–	800	8,6	* C 4028 V	* C 4028 K30V
	225	85	780	1 200	116	–	800	12,5	* C 4128 V/VE240 ¹⁾	* C 4128 K30V/VE240 ¹⁾
	250	68	830	1 060	102	2 400	3 200	14	* C 2228	* C 2228 K
150	225	56	540	850	81,5	2 400	3 200	8,45	* C 3030 MB ¹⁾	* C 3030 KMB ¹⁾
	225	56	585	960	93	–	1 000	8	* C 3030 V	* C 3030 KV
	225	75	780	1 320	127	–	750	10,5	* C 4030 V	* C 4030 K30V
	250	80	880	1 290	122	2 000	2 800	15,5	* C 3130	* C 3130 K
	250	100	1 220	1 860	176	–	450	20	* C 4130 V ¹⁾	* C 4130 K30V ¹⁾
	270	73	980	1 220	114	2 400	3 200	18	* C 2230	* C 2230 K
160	240	60	600	980	93	2 200	3 000	9,6	* C 3032 ¹⁾	* C 3032 K ¹⁾
	240	80	765	1 160	110	1 700	2 400	12,5	* C 4032	* C 4032 K30
	240	80	915	1 460	140	–	600	13	* C 4032 V	* C 4032 K30V
	270	86	1 000	1 400	129	1 900	2 600	21,5	* C 3132	* C 3132 K
	270	109	1 460	2 160	200	–	300	26	* C 4132 V ¹⁾	* C 4132 K30V ¹⁾
	290	104	1 370	1 830	170	1 800	2 400	29,5	* C 3232	* C 3232 K

¹⁾ Check availability prior to incorporating in a bearing arrangement design.

* SKF Explorer bearing

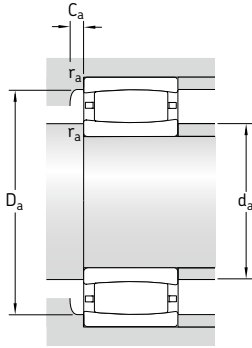

Dimensions						Abutment and fillet dimensions						Calculation factors	
d	d ₂	D ₁	r _{1,2} min.	s ₁ ¹⁾	s ₂ ¹⁾	d _a min.	d _a max.	D _a min.	D _a max.	C _a ²⁾	r _a	k ₁	k ₂
mm						mm						-	
120	138	166	2	10,6	-	130	148	160	170	0,9	2	0,111	0,109
	138	166	2	10,6	3,8	130	154	-	170	-	2	0,111	0,109
	140	164	2	12	5,2	130	152	-	170	-	2	0,109	0,103
	139	164	2	17,8	17,8	130	152	-	170	-	2	0,085	0,142
	140	176	2	18	11,2	131	160	-	189	-	2	0,104	0,103
144	191	2,1	13	-	132	163	142	203	1,1	2	0,104	0,113	
	149	190	2,1	17,1	-	132	162	179	203	2,4	2	0,103	0,108
	153	180	2	16,5	-	140	162	175	190	1,1	2	0,101	0,123
130	149	181	2	11,4	-	140	157	174	190	1,9	2	0,113	0,097
	149	181	2	11,4	4,6	140	167	-	190	-	2	0,113	0,097
	153	191	2	9,7	9,7	141	174	-	199	-	2	0,09	0,126
	152	199	3	9,6	-	144	171	185	216	1,1	2,5	0,113	0,101
	163	194	2	11	-	149	161	195	201	4,7	2	0,102	0,116
140	161	193	2	11,4	5,9	150	177	-	200	-	2	0,115	0,097
	166	204	2,1	9,7	9,7	152	189	-	213	-	2	0,086	0,134
	173	223	3	13,7	-	154	191	207	236	2,3	2,5	0,109	0,108
	173	204	2,1	8,7	-	161	172	198	214	1,3	2	0	0,108
150	174	204	2,1	14,1	7,3	161	190	-	214	-	2	0,113	0,108
	173	204	2,1	17,4	10,6	161	189	-	214	-	2	0,107	0,106
	182	226	2,1	13,9	-	162	196	214	238	2,3	2	0,12	0,092
	179	222	2,1	20	10,1	162	204	-	238	-	2	0,105	0,103
	177	236	3	11,2	-	164	202	215	256	2,5	2,5	0,119	0,096
	187	218	2,1	15	-	171	186	220	229	5,1	2	0,115	0,106
	181	217	2,1	18,1	-	171	190	209	229	2,2	2	0,109	0,103
160	181	217	2,1	18,1	8,2	171	199	-	229	-	2	0,109	0,103
	191	240	2,1	10,3	-	172	208	229	258	2,4	2	0,099	0,111
	190	241	2,1	21	11,1	172	199	-	258	-	2	0,101	0,105
	194	256	3	19,3	-	174	218	242	276	2,6	2,5	0,112	0,096

¹⁾ Permissible axial displacement from the normal position of one bearing ring relative to the other (→ page 968).

²⁾ Minimum width of free space for bearings with cage where the rings are aligned. For required free space when a ring is displaced → page 974.

9.1 CARB toroidal roller bearings d 170 – 280 mm

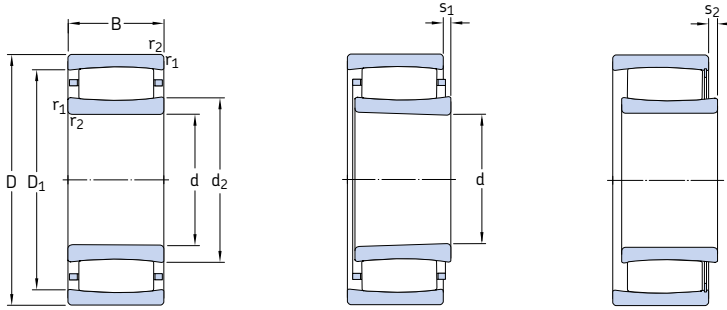

Cylindrical bore

Tapered bore

Full complement

Principal dimensions			Basic load ratings		Fatigue load limit P_u	Speed ratings		Mass	Designations	
d	D	B	dynamic C	static C_0		Reference speed	Limiting speed		Bearing with cylindrical bore	tapered bore
mm			kN		kN	r/min		kg	–	
170	260	67	750	1160	10,8	2 000	2 800	12,5	* C 3034 ¹⁾	* C 3034 K ¹⁾
	260	90	1140	1860	173	–	500	17,5	* C 4034 V	* C 4034 K30V
	280	88	1040	1460	137	1 900	2 600	21	* C 3134 ¹⁾	* C 3134 K ¹⁾
	280	109	1530	2280	208	–	280	27	* C 4134 V ¹⁾	* C 4134 K30V ¹⁾
	310	86	1270	1630	146	1 900	2 600	28	* C 2234	* C 2234 K
180	280	74	880	1340	122	2 000	2 600	17	* C 3036	* C 3036 K
	280	100	1320	2120	196	–	430	23,5	* C 4036 V	* C 4036 K30V
	300	96	1250	1730	156	1 700	2 400	26,5	* C 3136	* C 3136 K
	300	118	1760	2700	240	–	220	34,5	* C 4136 V ¹⁾	* C 4136 K30V ¹⁾
	320	112	1530	2200	193	1 500	2 000	38	* C 3236	* C 3236 K
190	290	75	930	1460	132	1 800	2 400	17,5	* C 3038	* C 3038 K
	290	100	1370	2320	208	–	380	24	* C 4038 V ¹⁾	* C 4038 K30V ¹⁾
	320	104	1700	2550	224	–	190	34,5	* C 3138 V ¹⁾	* C 3138 KV ¹⁾
	320	128	2040	3150	275	–	130	43	* C 4138 V ¹⁾	* C 4138 K30V ¹⁾
	340	92	1370	1730	153	1 800	2 400	34,5	* C 2238	* C 2238 K
200	310	82	1120	1730	153	1 700	2 400	22,5	* C 3040	* C 3040 K
	310	109	1630	2650	236	–	260	30,5	* C 4040 V	* C 4040 K30V
	340	112	1600	2320	200	1 500	2 000	41	* C 3140	* C 3140 K
	340	140	2360	3650	315	–	80	54	* C 4140 V ¹⁾	–
220	340	90	1320	2040	176	1 600	2 200	29,5	* C 3044	* C 3044 K
	340	118	1930	3250	275	–	200	40	* C 4044 V ¹⁾	* C 4044 K30V ¹⁾
	370	120	1900	2900	245	1 400	1 800	52	* C 3144	* C 3144 K
	400	108	2000	2500	208	1 500	2 000	57,5	* C 2244	* C 2244 K
240	360	92	1340	2160	183	1 500	2 000	32	* C 3048	* C 3048 K
	400	128	2320	3450	285	1 300	1 700	64	* C 3148	* C 3148 K
260	400	104	1760	2850	232	1 300	1 800	47	* C 3052	* C 3052 K
	440	144	2650	4050	325	1 100	1 500	88	* C 3152	* C 3152 K
280	420	106	1860	3100	250	1 200	1 600	50,5	* C 3056	* C 3056 K
	460	146	2850	4500	355	1 100	1 400	94,5	* C 3156	* C 3156 K

¹⁾ Check availability prior to incorporating in a bearing arrangement design.

* SKF Explorer bearing

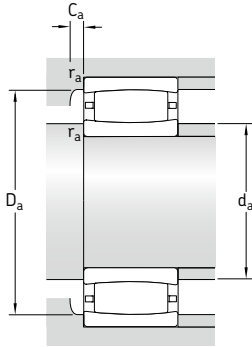

Dimensions					Abutment and fillet dimensions					Calculation factors				
d	d ₂	D ₁	r _{1,2} min.	s ₁ ¹⁾	s ₂ ¹⁾	d _a min.	d _a max.	D _a min.	D _a max.	C _a ²⁾	r _a	k ₁	k ₂	
mm						mm				-				
170	200	237	2,1	12,5	-	181	200	238	249	5,8	2	0,105	0,112	
	195	236	2,1	17,1	7,2	181	218	-	249	-	2	0,108	0,103	
	200	249	2,1	21	-	182	200	250	268	7,6	2	0,101	0,109	
	200	251	2,1	21	11,1	182	209	-	268	-	2	0,101	0,106	
	209	274	4	16,4	-	187	233	254	293	3	3	0,114	0,1	
180	209	251	2,1	15,1	-	191	223	239	269	2	2	0,112	0,105	
	203	247	2,1	20,1	10,2	191	229	-	269	-	2	0,107	0,103	
	210	266	3	23,2	-	194	231	252	286	2,2	2,5	0,102	0,111	
	211	265	3	20	10,1	194	223	-	286	-	2,5	0,095	0,11	
	228	289	4	27,3	-	197	249	271	303	3,2	3	0,107	0,104	
190	225	266	2,1	16,1	-	201	238	254	279	1,9	2	0,113	0,107	
	220	263	2,1	20	10,1	201	245	-	279	-	2	0,108	0,103	
	228	289	3	19	9,1	204	267	-	306	-	2,5	0,096	0,115	
	222	284	3	20	10,1	204	233	-	306	-	2,5	0,094	0,111	
	224	296	4	22,5	-	207	254	275	323	1,6	3	0,108	0,108	
200	235	285	2,1	15,2	-	211	250	272	299	2,9	2	0,123	0,095	
	228	280	2,1	21	11,1	211	263	-	299	-	2	0,11	0,101	
	244	305	3	27,3	-	214	264	288	326	-0,6 ³⁾	2,5	0,108	0,104	
	237	302	3	22	12,1	214	244	-	326	-	2,5	0,092	0,112	
220	257	310	3	17,2	-	233	274	295	327	3,1	2,5	0,114	0,104	
	251	306	3	20	10,1	233	250	-	327	-	2,5	0,095	0,113	
	268	333	4	22,3	-	237	290	315	353	3,5	3	0,114	0,097	
	259	350	4	20,5	-	237	298	321	383	1,7	3	0,113	0,101	
240	276	329	3	19,2	-	253	293	312	347	1,3	2,5	0,113	0,106	
	281	357	4	20,4	-	257	309	334	383	3,7	3	0,116	0,095	
260	305	367	4	19,3	-	275	326	349	385	3,4	3	0,122	0,096	
	314	394	4	26,4	-	277	341	371	423	4,1	3	0,115	0,096	
280	328	389	4	21,3	-	295	352	373	405	1,8	3	0,121	0,098	
	336	416	5	28,4	-	300	363	392	440	4,1	4	0,115	0,097	

¹⁾ Permissible axial displacement from the normal position of one bearing ring relative to the other (→ page 968).

²⁾ Minimum width of free space for bearings with cage where the rings are aligned. For required free space when a ring is displaced → page 974.

³⁾ To be used only when calculating the required free space (→ page 974).

9.1 CARB toroidal roller bearings d 300 – 460 mm

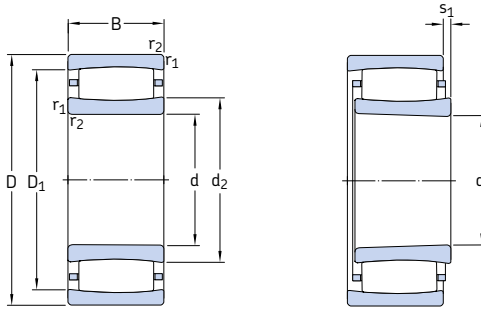

Cylindrical bore

Tapered bore

Principal dimensions			Basic load ratings		Fatigue load limit P_u	Speed ratings		Mass	Designations	
d	D	B	dynamic C	static C_0		Reference speed	Limiting speed		Bearing with cylindrical bore	tapered bore
mm			kN		kN	r/min		kg	–	
300	460	118	2 160	3 750	290	1 100	1 500	72	* C 3060 M	* C 3060 KM
	460	160	2 900	4 900	390	900	1 200	95,5	* C 4060 M	* C 4060 K30M
	500	160	3 250	5 200	400	950	1 300	125	* C 3160	* C 3160 K
320	480	121	2 280	4 000	305	1 000	1 400	78	* C 3064 M	* C 3064 KM
	540	176	4 150	6 300	480	900	1 300	164	* C 3164 M	* C 3164 KM
340	520	133	2 900	5 000	375	950	1 300	100	* C 3068 M ¹⁾	* C 3068 KM ¹⁾
	580	190	4 900	7 500	560	850	1 100	205	* C 3168 M	* C 3168 KM
360	480	90	1 760	3 250	245	1 000	1 400	45	* C 3972 M	* C 3972 KM
	540	134	2 900	5 000	375	900	1 300	106	* C 3072 M ¹⁾	* C 3072 KM ¹⁾
	600	192	5 000	8 000	585	800	1 100	220	* C 3172 M	* C 3172 KM
380	520	106	2 120	4 000	300	950	1 300	66	* C 3976 M	* C 3976 KM
	560	135	3 000	5 200	380	900	1 200	110	* C 3076 M ¹⁾	* C 3076 KM ¹⁾
	620	194	4 400	7 200	520	750	1 000	243	* C 3176 MB	* C 3176 KMB
400	540	106	2 120	4 000	290	900	1 300	68,5	* C 3980 M ¹⁾	* C 3980 KM ¹⁾
	600	148	3 650	6 200	450	800	1 100	145	* C 3080 M	* C 3080 KM
	650	200	4 800	8 300	585	700	950	258	* C 3180 M	* C 3180 KM
420	560	106	2 160	4 250	310	850	1 200	72	* C 3984 M	* C 3984 KM
	620	150	3 800	6 400	455	800	1 100	150	* C 3084 M	* C 3084 KM
	700	224	6 000	10 400	720	670	900	355	* C 3184 M	* C 3184 KM
440	600	118	2 600	5 300	375	800	1 100	99	* C 3988 M ¹⁾	* C 3988 KM ¹⁾
	650	157	3 750	6 400	450	750	1 000	190	* C 3088 MB	* C 3088 KMB
	720	226	6 700	11 400	780	630	850	385	* C 3188 MB	* C 3188 KMB
	720	280	7 500	12 900	900	500	670	471	* C 4188 MB	* C 4188 K30MB
460	620	118	2 700	5 300	375	800	1 100	100	* C 3992 M ¹⁾	* C 3992 KM ¹⁾
	680	163	4 000	7 500	520	700	950	205	* C 3092 M	* C 3092 KM
	760	240	6 800	12 000	815	600	800	435	* C 3192 M	* C 3192 KM
	760	300	8 650	15 000	1 020	480	630	571	* C 4192 MB	* C 4192 K30MB

¹⁾ Check availability prior to incorporating in a bearing arrangement design.

* SKF Explorer bearing

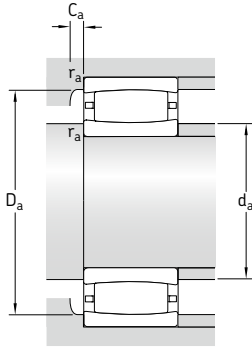

Dimensions					Abutment and fillet dimensions						Calculation factors	
d	d ₂	D ₁	r _{1,2}	s ₁ ¹⁾	d _a	d _a	D _a	D _a	C _a ²⁾	r _a	k ₁	k ₂
mm					mm						-	
300	351	417	4	20	315	376	402	445	1,7	3	0,123	0,095
	338	410	4	30,4	315	362	396	445	2,8	3	0,105	0,106
	362	448	5	30,5	320	392	422	480	4,9	4	0,106	0,106
320	375	441	4	23,3	335	398	426	465	1,8	3	0,121	0,098
	371	477	5	26,7	340	411	452	520	4,2	4	0,114	0,096
340	402	482	5	25,4	358	430	465	502	1,9	4	0,12	0,099
	402	517	5	25,9	360	446	489	560	4,2	4	0,118	0,093
360	394	450	3	17,2	373	409	435	467	1,6	2,5	0,127	0,104
	416	497	5	26,4	378	448	476	522	2	4	0,12	0,099
	423	537	5	27,9	380	464	507	580	3,9	4	0,117	0,094
380	428	489	4	21	395	450	475	505	1,8	3	0,129	0,098
	431	512	5	27	398	462	491	542	2	4	0,12	0,1
	446	551	5	25,4	400	445	526	600	7,3	4	0	0,106
400	439	501	4	21	415	461	487	525	1,8	3	0,13	0,098
	457	554	5	30,6	418	486	523	582	2,1	4	0,121	0,099
	488	589	6	50,7	426	525	566	624	4	5	0,106	0,109
420	461	523	4	21,3	435	484	510	545	1,8	3	0,132	0,098
	475	571	5	32,6	438	513	544	602	2,2	4	0,12	0,1
	507	618	6	34,8	446	544	592	674	3,8	5	0,113	0,098
440	494	560	4	20	455	517	546	585	1,9	3	0,133	0,095
	490	587	6	24,6	463	489	563	627	3,5	5	0	0,105
	522	647	6	16	466	521	613	694	7,5	5	0	0,099
	510	637	6	27,8	466	509	606	694	7,3	5	0	0,1
460	506	577	4	20	475	546	563	605	3,7	3	0,122	0,11
	539	624	6	33,5	483	570	604	657	2,3	5	0,114	0,108
	559	679	7,5	51	492	603	651	728	4,2	6	0,108	0,105
	537	671	7,5	23,3	477	536	638	728	13	6	0	0,097

¹⁾ Permissible axial displacement from the normal position of one bearing ring relative to the other (→ page 968).

²⁾ Minimum width of free space for bearings with cage where the rings are aligned. For required free space when a ring is displaced → page 974.

9.1 CARB toroidal roller bearings d 480 – 710 mm

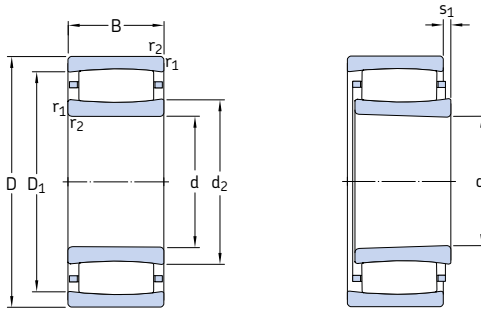

Cylindrical bore

Tapered bore

Principal dimensions			Basic load ratings		Fatigue load limit P_u	Speed ratings		Mass kg	Designations	
d	D	B	dynamic C	static C_0		Reference speed	Limiting speed		Bearing with cylindrical bore	tapered bore
mm			kN		kN	r/min		kg	–	
480	650	128	3 100	6 100	425	750	1 000	120	* C 3996 M	* C 3996 KM
	700	165	4 050	7 800	530	670	900	215	* C 3096 M	* C 3096 KM
	790	248	6 950	12 500	830	560	750	523	* C 3196 MB	* C 3196 KMB
500	670	128	3 150	6 300	430	700	950	125	* C 39/500 M	* C 39/500 KM
	720	167	4 250	8 300	560	630	900	225	* C 30/500 M	* C 30/500 KM
	830	264	7 500	12 700	850	530	750	560	* C 31/500 M	* C 31/500 KM
	830	325	9 800	17 600	1 160	430	560	710	* C 41/500 M	* C 41/500 K30M
530	710	136	3 550	7 100	480	670	900	150	* C 39/530 M	* C 39/530 KM
	780	185	5 100	9 500	630	600	800	300	* C 30/530 M	* C 30/530 KM
	870	272	8 800	15 600	1 020	500	670	636	* C 31/530 M	* C 31/530 KM
560	750	140	3 600	7 350	490	600	850	175	* C 39/560 M	* C 39/560 KM
	820	195	5 600	11 000	720	530	750	350	* C 30/560 M	* C 30/560 KM
	920	280	9 150	16 300	1 040	480	670	789	* C 31/560 MB	* C 31/560 KMB
	920	355	10 400	19 600	1 270	380	500	1 010	* C 41/560 MB	* C 41/560 K30MB
600	800	150	4 000	8 800	570	560	750	215	* C 39/600 M	* C 39/600 KM
	870	200	6 300	12 200	780	500	700	395	* C 30/600 M	* C 30/600 KM
	980	300	10 200	18 000	1 140	430	600	929	* C 31/600 MB	* C 31/600 KMB
	980	375	12 900	23 200	1 460	340	450	1 150	* C 41/600 MB ¹⁾	* C 41/600 K30MB ¹⁾
630	850	165	4 650	10 000	640	530	700	275	* C 39/630 M	* C 39/630 KM
	920	212	6 800	12 900	815	480	670	470	* C 30/630 M	* C 30/630 KM
	1 030	315	11 800	20 800	1 290	400	560	1 090	* C 31/630 MB	* C 31/630 KMB
670	900	170	4 900	11 200	695	480	630	315	* C 39/670 M	* C 39/670 KM
	980	230	8 150	16 300	1 000	430	600	590	* C 30/670 M	* C 30/670 KM
	1 090	336	11 800	21 200	1 290	380	500	1 300	* C 31/670 MB	* C 31/670 KMB
710	950	180	6 000	12 500	780	450	630	360	* C 39/710 M	* C 39/710 KM
	1 030	236	8 800	17 300	1 060	400	560	655	* C 30/710 M	* C 30/710 KM
	1 030	315	10 600	21 600	1 320	320	430	865	* C 40/710 M	* C 40/710 K30M
	1 150	345	13 400	25 500	1 530	340	480	1 470	* C 31/710 MB ¹⁾	* C 31/710 KMB ¹⁾

¹⁾ Check availability prior to incorporating in a bearing arrangement design.

* SKF Explorer bearing

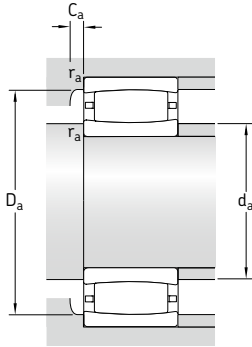

Dimensions					Abutment and fillet dimensions						Calculation factors	
d	d ₂	D ₁	r _{1,2}	s ₁ ¹⁾	d _a	d _a	D _a	D _a	C _a ²⁾	r _a	k ₁	k ₂
mm	~	~	min.		min.	max.	min.	max.			-	
480	528	604	5	20,4	498	552	585	632	2	4	0,133	0,095
	555	640	6	35,5	503	586	620	677	2,3	5	0,113	0,11
	578	701	7,5	35,1	512	577	673	758	8,7	6	0	0,109
500	555	632	5	20,4	518	580	614	652	2	4	0,135	0,095
	571	656	6	37,5	523	600	637	697	2,3	5	0,113	0,111
	605	738	7,5	75,3	532	654	706	798	-11,7 ³⁾	6	0,099	0,116
	600	740	7,5	46,3	532	637	721	798	5,9	6	0,115	0,093
530	577	658	5	28,4	548	603	639	692	2,3	4	0,129	0,101
	601	705	6	35,7	553	638	681	757	2,5	5	0,12	0,101
	635	781	7,5	44,4	562	685	745	838	5,4	6	0,115	0,097
560	621	701	5	32,4	578	648	682	732	2,3	4	0,128	0,104
	659	761	6	45,7	583	696	736	797	2,7	5	0,116	0,106
	660	808	7,5	24,5	592	659	769	888	11	6	0	0,1
	664	802	7,5	23	592	663	770	888	14	6	0	0,101
600	666	745	5	32,4	618	685	725	782	2,4	4	0,131	0,1
	692	805	6	35,9	623	728	776	847	2,7	5	0,125	0,098
	705	871	7,5	26,1	632	704	827	948	5,1	6	0	0,107
	697	869	7,5	24,6	632	696	823	948	5,5	6	0	0,097
630	699	785	6	35,5	653	723	766	827	2,4	5	0,121	0,11
	716	840	7,5	48,1	658	759	807	892	2,9	6	0,118	0,104
	741	916	7,5	23,8	662	740	868	998	5,7	6	0	0,102
670	764	848	6	40,5	693	789	830	877	2,5	5	0,121	0,113
	775	905	7,5	41,1	698	820	874	952	2,9	6	0,121	0,101
	792	964	7,5	41	702	791	922	1058	11	6	0	0,109
710	772	877	6	30,7	733	797	847	927	2,7	5	0,131	0,098
	806	946	7,5	47,3	738	853	908	1002	3,2	6	0,119	0,104
	803	935	7,5	51,2	738	843	911	1002	4,4	6	0,113	0,101
	842	1013	9,5	47,8	750	841	973	1110	11	8	0	0,094

¹⁾ Permissible axial displacement from the normal position of one bearing ring relative to the other (→ page 968).

²⁾ Minimum width of free space for bearings with cage where the rings are aligned. For required free space when a ring is displaced → page 974.

³⁾ To be used only when calculating the required free space (→ page 974).

9.1 CARB toroidal roller bearings d 750 – 1 500 mm

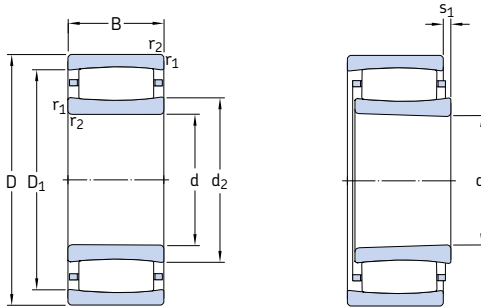

Cylindrical bore

Tapered bore

Principal dimensions			Basic load ratings		Fatigue load limit P_u	Speed ratings		Mass kg	Designations	
d	D	B	dynamic C	static C_0		Reference speed	Limiting speed		Bearing with cylindrical bore	tapered bore
mm			kN		kN	r/min		kg	–	
750	1 000	185	6 100	13 400	815	430	560	410	* C 39/750 M	* C 39/750 KM
	1 000	250	7 800	17 300	1 060	340	480	604	* C 49/750 MB1	* C 49/750 K30MB1
	1 090	250	9 500	19 300	1 160	380	530	838	* C 30/750 MB	* C 30/750 KMB
	1 220	365	16 000	30 500	1 800	320	450	1 810	* C 31/750 MB	* C 31/750 KMB
800	1 060	195	6 400	14 600	880	380	530	480	* C 39/800 M	* C 39/800 KM
	1 150	258	9 300	19 300	1 140	360	480	941	* C 30/800 MB	* C 30/800 KMB
	1 280	375	15 600	27 000	1 560	300	400	2 030	* C 31/800 MB ¹⁾	* C 31/800 KMB ¹⁾
850	1 120	200	7 350	16 300	960	360	480	540	* C 39/850 M	* C 39/850 KM
	1 220	272	11 600	24 500	1 430	320	450	1 110	* C 30/850 MB	* C 30/850 KMB
	1 360	400	16 600	33 500	1 900	280	380	2 450	* C 31/850 MB ¹⁾	* C 31/850 KMB ¹⁾
900	1 180	206	8 300	18 600	1 080	360	450	633	* C 39/900 MB	* C 39/900 KMB
	1 280	280	12 700	26 500	1 530	300	400	1 200	* C 30/900 MB	* C 30/900 KMB
950	1 250	224	9 300	22 000	1 250	300	430	784	* C 39/950 MB ¹⁾	* C 39/950 KMB ¹⁾
	1 360	300	13 200	28 500	1 600	280	380	1 480	* C 30/950 MB ¹⁾	* C 30/950 KMB ¹⁾
1 000	1 420	308	13 700	30 500	1 700	260	360	1 680	* C 30/1000 MB ¹⁾	* C 30/1000 KMB ¹⁾
	1 580	462	20 400	45 500	2 500	220	300	3 800	* C 31/1000 MB ¹⁾	* C 31/1000 KMB ¹⁾
1 060	1 400	250	11 000	26 000	1 430	260	360	1 120	* C 39/1060 MB	* C 39/1060 KMB
1 180	1 540	272	13 400	33 500	1 800	220	300	1 400	* C 39/1180 MB	* C 39/1180 KMB
1 250	1 750	375	22 000	49 000	2 550	180	240	2 980	* C 30/1250 MB ¹⁾	* C 30/1250 KMB
1 320	1 600	280	10 600	30 500	1 600	190	260	1 250	* C 48/1320 MB	* C 48/1320 K30MB
1 500	1 950	335	19 600	48 000	2 400	140	200	2 710	* C 39/1500 MB	* C 39/1500 KMB

¹⁾ Check availability prior to incorporating in a bearing arrangement design.

* SKF Explorer bearing

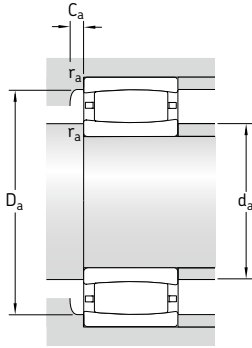

Dimensions					Abutment and fillet dimensions						Calculation factors	
d	d ₂ ~	D ₁ ~	r _{1,2} min.	s ₁ ¹⁾	d _a min.	d _a max.	D _a min.	D _a max.	C _a ²⁾	r _a	k ₁	k ₂
mm					mm						-	
750	830	934	6	35,7	773	856	908	977	2,7	5	0,131	0,101
	820	928	6	57,8	776	817	912	974	38	5	0	0,109
	854	993	7,5	28,6	778	852	961	1062	7,4	6	0	0,11
	884	1077	9,5	33	790	883	1025	1180	9,3	8	0	0,094
800	888	990	6	45,7	823	917	967	1037	2,9	5	0,126	0,106
	908	1048	7,5	45,9	828	905	1020	1122	7,2	6	0	0,114
	943	1134	9,5	39,4	840	941	1085	1240	14	8	0	0,097
850	940	1053	6	35,9	873	963	1025	1097	2,9	5	0,135	0,098
	964	1113	7,5	24	878	963	1077	1192	7,7	6	0	0,097
	1013	1201	12	62,8	898	1011	1159	1312	14	10	0	0,103
900	986	1113	6	22,9	923	984	1086	1157	5,8	5	0	0,101
	1005	1173	7,5	24,8	928	1003	1126	1252	9	6	0	0,1
950	1042	1167	7,5	14,5	978	1040	1139	1222	6,6	6	0	0,098
	1075	1241	7,5	37,8	978	1073	1204	1332	8,7	6	0	0,107
1000	1130	1295	7,5	44,9	1028	1128	1260	1392	8,5	6	0	0,11
	1191	1372	12	70,1	1048	1189	1338	1532	15	10	0	0,108
1060	1168	1308	7,5	38,4	1088	1164	1282	1372	6	6	0	0,11
1180	1291	1439	7,5	19,6	1208	1289	1405	1512	6,2	6	0	0,097
1250	1392	1614	9,5	40,3	1290	1390	1559	1710	12	8	0	0,126
1320	1408	1515	6	65,7	1343	1402	1512	1577	6,2	5	0	0,123
1500	1636	1831	9,5	35	1534	1633	1788	1916	9,3	8	0	0,096

¹⁾ Permissible axial displacement from the normal position of one bearing ring relative to the other (→ page 968).

²⁾ Minimum width of free space for bearings with cage where the rings are aligned. For required free space when a ring is displaced → page 974.

9.2 Sealed CARB toroidal roller bearings d 50 – 190 mm

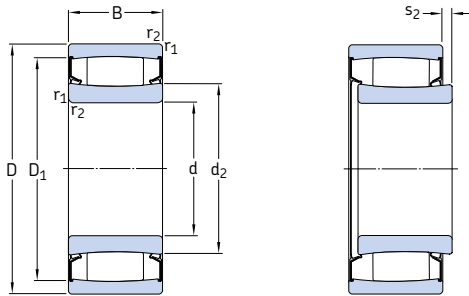

Principal dimensions			Basic load ratings		Fatigue load limit	Limiting speed	Mass	Designation
d	D	B	C	C ₀	P _u	r/min	kg	–
mm			kN		kN			
50	72	40	140	224	24,5	200	0,56	* C 6910-2CS5V/GEM9 ¹⁾
65	100	35	102	173	20,4	150	1,05	* C 4013-2CS5V/GEM9
75	105	54	204	325	37,5	140	1,4	* C 6915-2CS5V/GEM9
	115	40	143	193	23,2	130	1,4	* C 4015-2CS5V/GEM9 ¹⁾
90	125	46	224	400	44	110	1,75	* C 5918-2CS5V/GEM9
100	150	50	310	450	50	95	2,9	* C 4020-2CS5V/GEM9 ¹⁾
	165	65	475	655	69,5	90	5,2	* C 4120-2CS5V/GEM9 ¹⁾
110	170	60	415	585	63	85	4,6	* C 4022-2CS5V/GEM9 ¹⁾
	180	69	500	710	75	80	6,6	* C 4122-2CS5V/GEM9
120	180	60	430	640	67	80	5,1	* C 4024-2CS5V/GEM9
	200	80	710	1 000	100	75	9,7	* C 4124-2CS5V/GEM9 ¹⁾
130	200	69	550	830	85	70	7,5	* C 4026-2CS5V/GEM9
	210	80	750	1 100	108	70	10,5	* C 4126-2CS5V/GEM9
140	210	69	570	900	88	67	7,9	* C 4028-2CS5V/GEM9 ¹⁾
	225	85	780	1 200	116	63	12,5	* C 4128-2CS5V/GEM9
150	225	75	585	965	93	63	10	* C 4030-2CS5V/GEM9
	250	100	1 220	1 860	173	60	20,5	* C 4130-2CS5V/GEM9 ¹⁾
160	240	80	655	1 100	104	60	12	* C 4032-2CS5V/GEM9 ¹⁾
	270	109	1 460	2 160	200	53	26	* C 4132-2CS5V/GEM9 ¹⁾
170	260	90	965	1 630	150	53	17	* C 4034-2CS5V/GEM9 ¹⁾
	280	109	1 530	2 280	208	53	27	* C 4134-2CS5V/GEM9 ¹⁾
180	280	100	1 320	2 120	193	53	23,5	* C 4036-2CS5V/GEM9 ¹⁾
	300	118	1 760	2 700	240	48	35	* C 4136-2CS5V/GEM9 ¹⁾
190	290	100	1 370	2 320	204	48	24,5	* C 4038-2CS5V/GEM9 ¹⁾
	320	128	2 040	3 150	275	45	43,5	* C 4138-2CS5V/GEM9 ¹⁾

¹⁾ Check availability prior to incorporating in a bearing arrangement design.

* SKF Explorer bearing

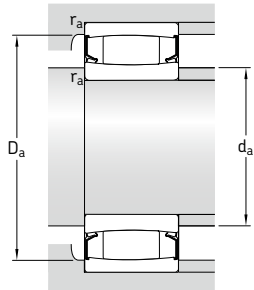

Dimensions					Abutment and fillet dimensions				Calculation factors	
d	d ₂ ~	D ₁ ~	r _{1,2} min.	s ₂ ¹⁾	d _a min.	d _a max.	D _a max.	r _a max.	k ₁	k ₂
mm					mm				-	
50	57,6	64,9	0,6	2,8	53,2	57	68,8	0,6	0,113	0,091
65	78,6	87,5	1,1	5,9	71	78,6	94	1	0,071	0,181
75	83,6 88,5	95,5 104	1 1,1	7,1 7,3	79,6 81	83 88	100 111	1 1	0,073 0,21	0,154 0,063
90	102	113	1,1	4,5	96	101	119	1	0,089	0,131
100	114 120	136 148	1,5 2	6,2 7,3	107 111	113 119	143 154	1,5 2	0,145 0,09	0,083 0,125
110	128 130	155 161	2 2	7,9 8,2	119 121	127 130	161 169	2 2	0,142 0,086	0,083 0,133
120	140 140	164 176	2 2	7,5 8,2	129 131	139 139	171 189	2 2	0,085 0,126	0,142 0,087
130	152 153	182 190	2 2	8,2 7,5	139 141	151 152	191 199	2 2	0,089 0,09	0,133 0,126
140	163 167	193 204	2 2,1	8,7 8,9	149 152	162 166	201 213	2 2	0,133 0,086	0,089 0,134
150	175 179	204 221	2,1 2,1	10,8 6,4	161 162	174 178	214 238	2 2	0,084 0,103	0,144 0,103
160	188 190	218 241	2,1 2,1	11,2 6,7	170 172	187 189	230 258	2 2	0,154 0,101	0,079 0,105
170	201 200	237 251	2,1 2,1	9 6,7	180 182	199 198	250 268	2 2	0,116 0,101	0,097 0,106
180	204 211	246 265	2,1 3	6,4 6,4	190 194	202 209	270 286	2 2,5	0,103 0,095	0,105 0,11
190	221 222	263 283	2,1 3	6,4 6,4	200 204	219 220	280 306	2 2,5	0,103 0,094	0,106 0,111

¹⁾ Permissible axial displacement from the normal position of one bearing ring relative to the other (→ page 968).

9.2 Sealed CARB toroidal roller bearings d 200 mm

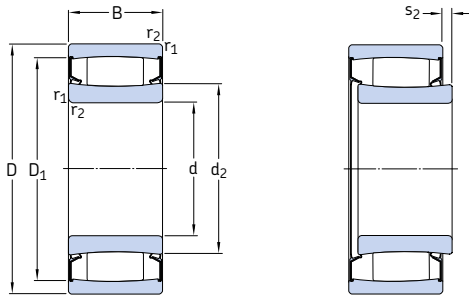

Principal dimensions			Basic load ratings		Fatigue load limit	Limiting speed	Mass	Designation
d	D	B	C dynamic	C ₀ static	P _u			
mm			kN		kN	r/min	kg	–
200	310	109	1 630	2 650	232	45	31	* C 4040-2CS5V/GEM9 ¹⁾
	340	140	2 360	3 650	315	43	54,5	* C 4140-2CS5V/GEM9 ¹⁾

¹⁾ Check availability prior to incorporating in a bearing arrangement design.

* SKF Explorer bearing

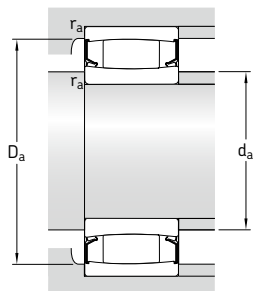

Dimensions					Abutment and fillet dimensions				Calculation factors	
d	d ₂ ~	D ₁ ~	r _{1,2} min.	s ₂ ¹⁾	d _a min.	d _a max.	D _a max.	r _a max.	k ₁	k ₂
mm					mm				-	
200	229 237	280 301	2,1 3	6,7 7	210 214	227 235	300 326	2 2,5	0,101 0,092	0,108 0,112

9.2

¹⁾ Permissible axial displacement from the normal position of one bearing ring relative to the other (→ page 968).

9.3 CARB toroidal roller bearings on an adapter sleeve

d_1 20 – 180 mm

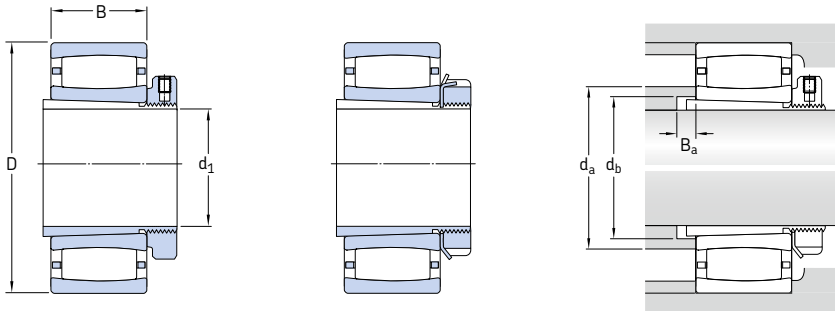

Bearing on an E design sleeve

Bearing on a standard sleeve

Principal dimensions			Abutment and fillet dimensions			Mass Bearing incl. sleeve	Designations Bearing ¹⁾	Adapter sleeve ²⁾
d_1	D	B	d_a max.	d_b min.	B_a min.	kg	-	
mm	mm	mm	mm	mm	mm			
20	52	18	32	28	5	0,2	* C 2205 KTN9 ³⁾	H 305 E
	52	18	40	28	5	0,25	* C 2205 KV ³⁾	H 305 E
25	62	20	37,4	33	5	0,37	* C 2206 KTN9	H 306 E
	62	20	49	33	5	0,39	* C 2206 KV	H 306 E
30	72	23	44,8	39	5	0,59	* C 2207 KTN9	H 307 E
	72	23	57	39	5	0,59	* C 2207 KV	H 307 E
35	80	23	52,4	44	5	0,69	* C 2208 KTN9	H 308 E
	80	23	66	44	5	0,7	* C 2208 KV	H 308 E
40	85	23	55,6	50	7	0,76	* C 2209 KTN9	H 309 E
	85	23	69	50	7	0,79	* C 2209 KV	H 309 E
45	90	23	61,9	55	9	0,85	* C 2210 KTN9	H 310 E
	90	23	73	55	9	0,89	* C 2210 KV	H 310 E
50	100	25	65,8	60	10	1,1	* C 2211 KTN9	H 311 E
	100	25	80	60	10	1,15	* C 2211 KV	H 311 E
55	110	28	77,1	65	9	1,45	* C 2212 KTN9	H 312 E
	110	28	91	65	9	1,5	* C 2212 KV	H 312 E
60	120	31	79	70	8	1,8	* C 2213 KTN9	H 313 E
	120	31	97	70	8	1,9	* C 2213 KV	H 313 E
	125	31	83,7	75	9	2,1	* C 2214 KTN9	H 314 E
	125	31	102	75	9	2,2	* C 2214 KV	H 314 E
	150	51	106	76	6	5,1	* C 2314 K	H 2314
65	130	31	98,3	80	12	2,3	* C 2215 K	H 315 E
	130	31	107	80	12	2,4	* C 2215 KV	H 315 E
	160	55	113	82	6	6,2	* C 2315 K	H 2315

¹⁾ For additional bearing data → product tables, page 980

²⁾ For additional adapter sleeve data → product tables, page 1290

³⁾ Check availability prior to incorporating in a bearing arrangement design.

* SKF Explorer bearing

Principal dimensions			Abutment and fillet dimensions			Mass Bearing incl. sleeve	Designations Bearing ¹⁾	Adapter sleeve ²⁾
d ₁	D	B	d _a max.	d _b min.	B _a min.			
mm			mm			kg	-	
70	140	33	107	85	12	2,9	* C 2216 K	H 316 E
	140	33	116	85	12	3	* C 2216 KV	H 316
	170	58	119	88	6	7,4	* C 2316 K	H 2316
75	150	36	114	91	12	3,7	* C 2217 K	H 317 E
	150	36	120	91	12	3,85	* C 2217 KV	H 317
	180	60	126	94	7	8,5	* C 2317 K	H 2317
80	160	40	124	96	10	4,5	* C 2218 K	H 318 E
	160	40	131	96	10	4,7	* C 2218 KV ³⁾	H 318
	190	64	138	100	7	10	* C 2318 K	H 2318
85	170	43	124	102	9	5,3	* C 2219 K ³⁾	H 319 E
	200	67	138	105	7	11,5	* C 2319 K	H 2319
90	165	52	136	107	6	6,1	* C 3120 KV	H 3120 E
	180	46	134	108	8	6,3	* C 2220 K	H 320 E
	215	73	150	110	7	14,5	* C 2320 K	H 2320
100	170	45	138	118	14	5,5	* C 3022 K ³⁾	H 322 E
	200	53	150	118	6	8,8	* C 2222 K	H 322 E
110	180	46	148	127	7	5,7	* C 3024 K ³⁾	H 3024 E
	180	46	154	127	7	5,85	* C 3024 KV	H 3024
	215	58	163	128	11	8,6	* C 2224 K ³⁾	H 3124 L
	215	76	162	131	17	14	* C 3224 K	H 2324 L
115	200	52	162	137	8	8,7	* C 3026 K ³⁾	H 3026
	230	64	171	138	8	14	* C 2226 K	H 3126 L
125	210	53	161	147	8	9,3	* C 3028 K ³⁾	H 3028 E
	250	68	191	149	8	17,5	* C 2228 K	H 3128 L
135	225	56	172	158	8	12	* C 3030 KMB ³⁾	H 3030 E
	225	56	190	158	8	11,5	* C 3030 KV	H 3030
	250	80	196	160	8	20	* C 3130 K	H 3130 L
	270	73	202	160	15	23	* C 2230 K	H 3130 L
140	240	60	186	168	9	14,5	* C 3032 K ³⁾	H 3032 E
	270	86	208	170	8	27	* C 3132 K	H 3132 L
	290	104	218	174	18	36,5	* C 3232 K	H 2332 L
150	260	67	200	179	9	18	* C 3034 K ³⁾	H 3034 E
	280	88	200	180	8	29	* C 3134 K ³⁾	H 3134 E
	310	86	233	180	10	35	* C 2234 K	H 3134 L
160	280	74	223	189	9	23	* C 3036 K	H 3036
	300	96	231	191	8	34	* C 3136 K	H 3136 L
	320	112	249	195	22	47	* C 3236 K	H 2336
170	290	75	238	199	10	24	* C 3038 K	H 3038
	320	104	267	202	9	45	* C 3138 KV ³⁾	H 3138
	340	92	254	202	21	43	* C 2238 K	H 3138
180	310	82	250	210	10	30	* C 3040 K	H 3040
	340	112	264	212	9	50,5	* C 3140 K	H 3140

1) For additional bearing data → **product tables, page 980**

2) For additional adapter sleeve data → **product tables, page 1290**

3) Check availability prior to incorporating in a bearing arrangement design.

* SKF Explorer bearing

9.3 CARB toroidal roller bearings on an adapter sleeve

d_1 200 – 1 000 mm

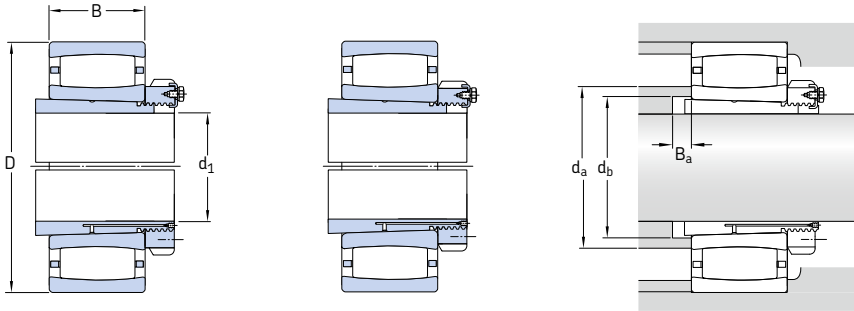

Bearing on an
OH .. H design sleeve

Bearing on an
OH .. HE design sleeve

Principal dimensions			Abutment and fillet dimensions			Mass Bearing incl. sleeve	Designations Bearing ¹⁾	Adapter sleeve ²⁾
d_1	D	B	d_a max.	d_b min.	B_a min.			
mm			mm	mm	mm	kg	–	
200	340	90	274	231	10	37	* C 3044 K	OH 3044 H
	370	120	290	233	10	64	* C 3144 K	OH 3144 HTL
	400	108	298	233	22	69	* C 2244 K	OH 3144 H
220	360	92	293	251	11	42,5	* C 3048 K	OH 3048 H
	400	128	309	254	11	77	* C 3148 K	OH 3148 HTL
240	400	104	326	272	11	59	* C 3052 K	OH 3052 H
	440	144	341	276	11	105	* C 3152 K	OH 3152 HTL
260	420	106	352	292	12	65	* C 3056 K	OH 3056 H
	460	146	363	296	12	115	* C 3156 K	OH 3156 HTL
280	460	118	376	313	12	91	* C 3060 KM	OH 3060 H
	500	160	392	318	12	150	* C 3160 K	OH 3160 H
300	480	121	398	334	13	95	* C 3064 KM	OH 3064 H
	540	176	411	338	13	190	* C 3164 KM	OH 3164 H
320	520	133	430	355	14	125	* C 3068 KM ³⁾	OH 3068 H
	580	190	446	360	14	235	* C 3168 KM	OH 3168 H
340	480	90	409	372	14	73	* C 3972 KM	OH 3972 HE
	540	134	448	375	14	135	* C 3072 KM ³⁾	OH 3072 H
	600	192	464	380	14	250	* C 3172 KM	OH 3172 H
360	520	106	450	393	15	95	* C 3976 KM	OH 3976 HE
	560	135	462	396	15	145	* C 3076 KM ³⁾	OH 3076 H
	620	194	445	401	15	290	* C 3176 KMB	OH 3176 HE
380	540	106	461	413	15	105	* C 3980 KM ³⁾	OH 3980 HE
	600	148	486	417	15	175	* C 3080 KM	OH 3080 H
	650	200	525	421	15	345	* C 3180 KM	OH 3180 H
400	560	106	484	433	15	106	* C 3984 KM	OH 3984 HE
	620	150	513	437	16	180	* C 3084 KM	OH 3084 H
	700	224	544	443	16	395	* C 3184 KM	OH 3184 H

¹⁾ For additional bearing data → **product tables, page 980**

²⁾ For additional adapter sleeve data → **product tables, page 1290**

³⁾ Check availability prior to incorporating in a bearing arrangement design.

* SKF Explorer bearing

Principal dimensions			Abutment and fillet dimensions			Mass Bearing incl. sleeve	Designations Bearing ¹⁾	Adapter sleeve ²⁾
d ₁	D	B	d _a max.	d _B min.	B _a min.			
mm			mm			kg	-	
410	600	118	517	454	17	155	* C 3988 KM ³⁾	OH 3988 HE
	650	157	489	458	17	250	* C 3088 KMB	OH 3088 HE
	720	226	521	463	17	475	* C 3188 KMB	OH 3188 HE
430	620	118	546	474	17	160	* C 3992 KM ³⁾	OH 3992 H
	680	163	570	478	17	270	* C 3092 KM	OH 3092 H
	760	240	603	484	17	540	* C 3192 KM	OH 3192 H
450	650	128	552	496	18	185	* C 3996 KM	OH 3996 HE
	700	165	586	499	18	275	* C 3096 KM	OH 3096 H
	790	248	577	505	18	620	* C 3196 KMB	OH 3196 HE
470	670	128	580	516	18	195	* C 39/500 KM	OH 39/500 HE
	720	167	600	519	18	305	* C 30/500 KM	OH 30/500 H
	830	264	654	527	18	690	* C 31/500 KM	OH 31/500 H
500	710	136	603	547	20	230	* C 39/530 KM	OH 39/530 HE
	780	185	638	551	20	390	* C 30/530 KM	OH 30/530 H
	870	272	685	558	20	770	* C 31/530 KM	OH 31/530 H
530	750	140	648	577	20	260	* C 39/560 KM	OH 39/560 HE
	820	195	696	582	20	440	* C 30/560 KM	OH 30/560 H
	920	280	659	589	20	930	* C 31/560 KMB	OH 31/560 HE
560	800	150	685	619	22	325	* C 39/600 KM	OH 39/600 HE
	870	200	728	623	22	520	* C 30/600 KM	OH 30/600 H
	980	300	704	629	22	1 100	* C 31/600 KMB	OH 31/600 HE
600	850	165	723	650	22	420	* C 39/630 KM	OH 39/630 HE
	920	212	759	654	22	635	* C 30/630 KM	OH 30/630 H
	1 030	315	740	663	22	1 280	* C 31/630 KMB	OH 31/630 HE
630	900	170	789	691	22	455	* C 39/670 KM	OH 39/670 H
	980	230	820	696	22	750	* C 30/670 KM	OH 30/670 H
	1 090	336	791	705	22	1 550	* C 31/670 KMB	OH 31/670 HE
670	950	180	797	732	26	520	* C 39/710 KM	OH 39/710 HE
	1 030	236	853	736	26	865	* C 30/710 KM	OH 30/710 H
	1 150	345	841	745	26	1 800	* C 31/710 KMB ³⁾	OH 31/710 HE
710	1 000	185	856	772	26	590	* C 39/750 KM	OH 39/750 HE
	1 090	250	852	778	26	1 000	* C 30/750 KMB	OH 30/750 HE
	1 220	365	883	787	26	2 150	* C 31/750 KMB	OH 31/750 HE
750	1 060	195	917	822	28	715	* C 39/800 KM	OH 39/800 HE
	1 150	258	905	829	28	1 150	* C 30/800 KMB	OH 30/800 HE
	1 280	375	941	838	28	2 400	* C 31/800 KMB ³⁾	OH 31/800 HE
800	1 120	200	963	872	28	785	* C 39/850 KM	OH 39/850 HE
	1 220	272	963	880	28	1 050	* C 30/850 KMB	OH 30/850 HE
	1 360	400	1 011	890	28	2 260	* C 31/850 KMB ³⁾	OH 31/850 HE
850	1 180	206	984	924	30	900	* C 39/900 KMB	OH 39/900 HE
	1 280	280	1 003	931	30	1 520	* C 30/900 KMB	OH 30/900 HE
900	1 250	224	1 040	976	30	1 100	* C 39/950 KMB ³⁾	OH 39/950 HE
	1 360	300	1 073	983	30	1 800	* C 30/950 KMB ³⁾	OH 30/950 HE
950	1 420	308	1 128	1 034	33	2 000	* C 30/1000 KMB ³⁾	OH 30/1000 HE
	1 580	462	1 189	1 047	33	4 300	* C 31/1000 KMB ³⁾	OH 31/1000 HE
1 000	1 400	250	1 164	1 087	33	1 610	* C 39/1060 KMB	OH 39/1060 HE

¹⁾ For additional bearing data → **product tables, page 980**

²⁾ For additional adapter sleeve data → **product tables, page 1290**

³⁾ Check availability prior to incorporating in a bearing arrangement design.

* SKF Explorer bearing

9.4 CARB toroidal roller bearings on a withdrawal sleeve

d_1 35 – 170 mm

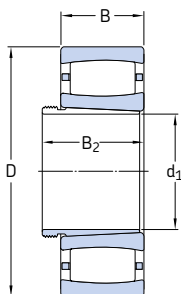

Dimensions				Mass Bearing incl. sleeve	Designations Bearing ¹⁾	Withdrawal sleeve ²⁾
d_1	D	B	$B_2^{3)}$			
mm				kg	-	
35	80	23	32	0,59	* C 2208 KTN9	AH 308
	80	23	32	0,62	* C 2208 KV	AH 308
40	85	23	34	0,67	* C 2209 KTN9	AH 309
	85	23	34	0,7	* C 2209 KV	AH 309
45	90	23	38	0,72	* C 2210 KTN9	AHX 310
	90	23	38	0,75	* C 2210 KV	AHX 310
50	100	25	40	0,95	* C 2211 KTN9	AHX 311
	100	25	40	0,97	* C 2211 KV	AHX 311
55	110	28	43	1,3	* C 2212 KTN9	AHX 312
	110	28	43	1,35	* C 2212 KV	AHX 312
60	120	31	45	1,6	* C 2213 KTN9	AH 313 G
	120	31	45	1,7	* C 2213 KV	AH 313 G
65	125	31	47	1,7	* C 2214 KTN9	AH 314 G
	125	31	47	1,75	* C 2214 KV	AH 314 G
	150	51	68	4,65	* C 2314 K	AHX 2314 G
70	130	31	49	1,9	* C 2215 K	AH 315 G
	130	31	49	1,95	* C 2215 KV	AH 315 G
	160	55	72	5,65	* C 2315 K	AHX 2315 G
75	140	33	52	2,35	* C 2216 K	AH 316
	140	33	52	2,45	* C 2216 KV	AH 316
	170	58	75	6,75	* C 2316 K	AHX 2316
80	150	36	56	3	* C 2217 K	AHX 317
	150	36	56	3,2	* C 2217 KV	AHX 317
	180	60	78	7,9	* C 2317 K	AHX 2317

¹⁾ For additional bearing data → **product tables, page 980**

²⁾ For additional withdrawal sleeve data → **product tables, page 1310**

³⁾ Width before the sleeve is driven into the bearing bore

* SKF Explorer bearing

Dimensions				Mass Bearing incl. sleeve	Designations Bearing ¹⁾	Withdrawal sleeve ²⁾
d ₁	D	B	B ₂ ³⁾			
mm				kg	–	
85	160	40	57	3,75	* C 2218 K	AHX 318
	160	40	57	3,85	* C 2218 KV ⁴⁾	AHX 318
	190	64	83	9	* C 2318 K	AHX 2318
90	170	43	61	4,5	* C 2219 K ⁴⁾	AHX 319
	200	67	89	11	* C 2319 K	AHX 2319
95	165	52	68	5	* C 3120 KV	AHX 3120
	180	46	63	5,3	* C 2220 K	AHX 320
	215	73	94	13,5	* C 2320 K	AHX 2320
105	170	45	72	4,25	* C 3022 K ⁴⁾	AHX 3122
	180	69	91	7,75	* C 4122 K30V	AH 24122
	200	53	72	7,65	* C 2222 K	AHX 3122
115	180	46	64	4,6	* C 3024 K ⁴⁾	AHX 3024
	180	46	64	4,75	* C 3024 KV	AHX 3024
	180	60	82	5,65	* C 4024 K30V/VE240	AH 24024
	180	60	82	6,2	* C 4024 K30V	AH 24024
	200	80	102	11,5	* C 4124 K30V ⁴⁾	AH 24124
	215	58	79	9,5	* C 2224 K ⁴⁾	AHX 3124
215	76	94	13	* C 3224 K	AHX 3224 G	
125	200	52	71	6,8	* C 3026 K ⁴⁾	AHX 3026
	200	69	93	8,7	* C 4026 K30	AH 24026
	200	69	93	8,9	* C 4026 K30V	AH 24026
	210	80	104	11,5	* C 4126 K30V/VE240	AH 24126
	230	64	82	12	* C 2226 K	AHX 3126
135	210	53	73	7,3	* C 3028 K ⁴⁾	AHX 3028
	210	69	93	9,5	* C 4028 K30V	AH 24028
	225	85	109	14	* C 4128 K30V/VE240 ⁴⁾	AH 24128
	250	68	88	15,5	* C 2228 K	AHX 3128
145	225	56	77	9,4	* C 3030 KMB ⁴⁾	AHX 3030
	225	56	77	8,9	* C 3030 KV	AHX 3030
	225	75	101	11,5	* C 4030 K30V	AH 24030
	250	80	101	16,5	* C 3130 K	AHX 3130 G
	250	100	126	22	* C 4130 K30V ⁴⁾	AH 24130
	270	73	101	19	* C 2230 K	AHX 3130 G
150	240	60	82	11,5	* C 3032 K ⁴⁾	AH 3032
	240	80	106	14,5	* C 4032 K30	AH 24032
	240	80	106	15	* C 4032 K30V	AH 24032
	270	86	108	23	* C 3132 K	AH 3132 G
	270	109	135	29	* C 4132 K30V ⁴⁾	AH 24132
	290	104	130	31	* C 3232 K	AH 3232 G
160	260	67	90	15	* C 3034 K ⁴⁾	AH 3034
	260	90	117	20	* C 4034 K30V	AH 24034
	280	88	109	24	* C 3134 K ⁴⁾	AH 3134 G
	280	109	136	30	* C 4134 K30V ⁴⁾	AH 24134
	310	86	109	31	* C 2234 K	AH 3134 G
170	280	74	98	19	* C 3036 K	AH 3036
	280	100	127	26	* C 4036 K30V	AH 24036
	300	96	122	30	* C 3136 K	AH 3136 G
	300	118	145	38	* C 4136 K30V ⁴⁾	AH 24136
	320	112	146	41,5	* C 3236 K	AH 3236 G

1) For additional bearing data → **product tables, page 980**

2) For additional withdrawal sleeve data → **product tables, page 1310**

3) Width before the sleeve is driven into the bearing bore

4) Check availability prior to incorporating in a bearing arrangement design.

* SKF Explorer bearing

9.4 CARB toroidal roller bearings on a withdrawal sleeve

d_1 180 – 950 mm

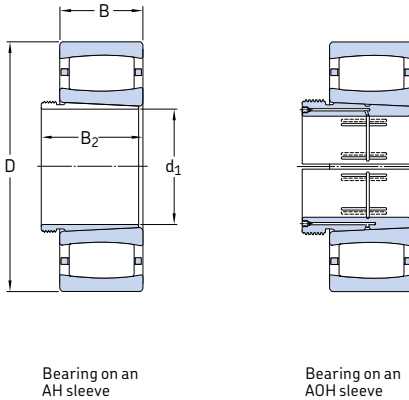

Dimensions				Mass Bearing incl. sleeve	Designations Bearing ¹⁾	Withdrawal sleeve ²⁾
d_1	D	B	B_2 ³⁾			
mm				kg	–	
180	290	75	102	20,5	* C 3038 K	AH 3038 G
	290	100	131	28	* C 4038 K30V ⁴⁾	AH 24038
	320	104	131	39	* C 3138 KV ⁴⁾	AH 3138 G
	320	128	159	47,5	* C 4138 K30V ⁴⁾	AH 24138
	340	92	117	38	* C 2238 K	AH 2238 G
190	310	82	108	25,5	* C 3040 K	AH 3040 G
	310	100	140	34,5	* C 4040 K30V	AH 24040
	340	112	140	45,5	* C 3140 K	AH 3140
200	340	90	117	36	* C 3044 K	AOH 3044 G
	340	118	152	48	* C 4044 K30V ⁴⁾	AOH 24044
	370	120	151	60	* C 3144 K	AOH 3144
	400	108	136	65,5	* C 2244 K	AOH 2244
220	360	92	123	39,5	* C 3048 K	AOH 3048
	400	128	161	75	* C 3148 K	AOH 3148
240	400	104	135	55,5	* C 3052 K	AOH 3052
	440	144	179	102	* C 3152 K	AOH 3152 G
260	420	106	139	61	* C 3056 K	AOH 3056
	460	146	183	110	* C 3156 K	AOH 3156 G
280	460	118	153	84	* C 3060 KM	AOH 3060
	460	160	202	110	* C 4060 K30M	AOH 24060 G
	500	160	200	140	* C 3160 K	AOH 3160 G
300	480	121	157	93	* C 3064 KM	AOH 3064 G
	540	176	217	185	* C 3164 KM	AOH 3164 G
320	520	133	171	120	* C 3068 KM ⁴⁾	AOH 3068 G
	580	190	234	230	* C 3168 KM	AOH 3168 G

¹⁾ For additional bearing data → **product tables, page 980**

²⁾ For additional withdrawal sleeve data → **product tables, page 1310**

³⁾ Width before the sleeve is driven into the bearing bore

⁴⁾ Check availability prior to incorporating in a bearing arrangement design.

* SKF Explorer bearing

Dimensions				Mass Bearing incl. sleeve	Designations Bearing ¹⁾	Withdrawal sleeve ²⁾
d ₁	D	B	B ₂ ³⁾			
mm				kg	–	
340	540	134	176	125	* C 3072 KM ⁴⁾	AOH 3072 G
	600	192	238	245	* C 3172 KM	AOH 3172 G
360	560	135	180	130	* C 3076 KM ⁴⁾	AOH 3076 G
	620	194	242	260	* C 3176 KMB	AOH 3176 G
380	600	148	193	165	* C 3080 KM	AOH 3080 G
	650	200	250	310	* C 3180 KM	AOH 3180 G
400	620	150	196	175	* C 3084 KM	AOH 3084 G
	700	224	276	380	* C 3184 KM	AOH 3184 G
420	650	157	205	215	* C 3088 KMB	AOHX 3088 G
	720	226	281	405	* C 3188 KMB	AOHX 3188 G
	720	280	332	510	* C 4188 K30MB	AOH 24188
440	680	163	213	230	* C 3092 KM	AOHX 3092 G
	760	240	296	480	* C 3192 KM	AOHX 3192 G
	760	300	355	621	* C 4192 K30MB	AOH 24192
460	700	165	217	245	* C 3096 KM	AOHX 3096 G
	790	248	307	545	* C 3196 KMB	AOHX 3196 G
480	720	167	221	265	* C 30/500 KM	AOHX 30/500 G
	830	264	325	615	* C 31/500 KM	AOHX 31/500 G
500	780	185	242	355	* C 30/530 KM	AOH 30/530
	870	272	337	720	* C 31/530 KM	AOH 31/530
530	820	195	252	415	* C 30/560 KM	AOHX 30/560
	920	280	347	855	* C 31/560 KMB	AOH 31/560
	920	355	417	989	* C 41/560 K30MB	AOH 241560 G
570	870	200	259	460	* C 30/600 KM	AOHX 30/600
	980	300	369	990	* C 31/600 KMB	AOHX 31/600
	980	375	439	1 270	* C 41/600 K30MB ⁴⁾	AOHX 241600
600	920	212	272	555	* C 30/630 KM	AOH 30/630
	1 030	315	389	1 180	* C 31/630 KMB	AOH 31/630
630	980	230	294	705	* C 30/670 KM	AOH 30/670
	1 090	336	409	1 410	* C 31/670 KMB	AOHX 31/670
670	1 030	236	302	780	* C 30/710 KM	AOHX 30/710
	1 030	315	389	1 010	* C 40/710 K30M	AOH 240/710 G
	1 150	345	421	1 600	* C 31/710 KMB ⁴⁾	AOHX 31/710
710	1 090	250	316	920	* C 30/750 KMB	AOH 30/750
	1 220	365	441	1 930	* C 31/750 KMB	AOH 31/750
750	1 150	258	326	1 060	* C 30/800 KMB	AOH 30/800
	1 280	375	456	2 170	* C 31/800 KMB ⁴⁾	AOH 31/800
800	1 220	272	343	1 280	* C 30/850 KMB	AOH 30/850
	1 360	400	480	2 600	* C 31/850 KMB ⁴⁾	AOH 31/850
850	1 280	280	355	1 400	* C 30/900 KMB	AOH 30/900
900	1 360	300	375	1 700	* C 30/950 KMB ⁴⁾	AOH 30/950
950	1 420	308	387	1 880	* C 30/1000 KMB ⁴⁾	AOH 30/1000
	1 580	462	547	3 950	* C 31/1000 KMB ⁴⁾	AOH 31/1000

1) For additional bearing data → **product tables, page 980**

2) For additional withdrawal sleeve data → **product tables, page 1310**

3) Width before the sleeve is driven into the bearing bore

4) Check availability prior to incorporating in a bearing arrangement design.

* SKF Explorer bearing



SKF

10 Thrust ball bearings

Designs and variants	1010
Single direction thrust ball bearings . . .	1010
Double direction thrust ball bearings ..	1010
Cages.	1010
Bearings with sphered housing washers	1011

Bearing data	1012
(Dimension standards, tolerances, misalignment, friction, starting torque, power loss, defect frequencies)	

Loads	1013
(Minimum load, equivalent loads)	

Temperature limits.	1014
--------------------------------------	-------------

Permissible speed.	1014
-------------------------------------	-------------

Mounting	1014
---------------------------	-------------

Designation system	1015
-------------------------------------	-------------

Product tables

10.1 Single direction thrust ball bearings	1016
10.2 Single direction thrust ball bearings with a sphered housing washer.	1026
10.3 Double direction thrust ball bearings	1030
10.4 Double direction thrust ball bearings with sphered housing washers.	1034

Other thrust ball bearings

Bearings with Solid Oil	1185
SKF DryLube bearings	1191
NoWear coated bearings	1241
Polymer ball bearings	1247



Designs and variants

SKF thrust ball bearings are manufactured as single direction or double direction thrust ball bearings. They are designed to accommodate axial loads only and must not be subjected to any radial load.

SKF thrust ball bearings are separable, i.e. the shaft washer, housing washer(s), ball and cage assembly(s) can be mounted separately.

Shaft washers have a ground bore to enable an interference fit. The bore of the housing washer is turned and always larger than the shaft washer bore.

Single direction thrust ball bearings

SKF single direction thrust ball bearings consist of a shaft washer, a housing washer and a ball and cage assembly (→ **fig. 1**). As their name implies, single direction thrust ball bearings can accommodate axial loads and locate a shaft axially, in one direction only.

Double direction thrust ball bearings

SKF double direction thrust ball bearings consist of one shaft washer, two housing washers and two ball and cage assemblies (→ **fig. 2**). The housing washers and ball and cage assemblies of double direction bearings are identical to those used in single direction bearings. Double direction thrust ball bearings can accommodate axial loads and locate a shaft axially, in both directions.

More information

Bearing life and load ratings	63
Design considerations	159
Recommended fits	169
Abutment and fillet dimensions	208
Lubrication	239
Mounting, dismantling and bearing care	271

Fig. 1

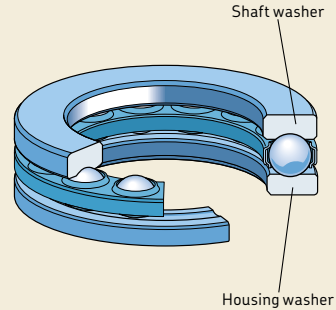
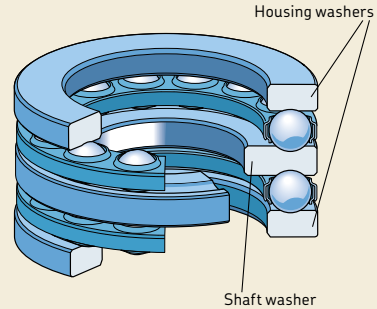

Fig. 2



Cages

Depending on their series and size, SKF thrust ball bearings are fitted with one of the cages shown in **table 1**.

The lubricants generally used for rolling bearings do not have a detrimental effect on cage properties. For additional information about the suitability of cages, refer to *Cages* (→ **page 37**) and *Cage materials* (→ **page 152**).

Bearings with sphered housing washers

To accommodate initial misalignment between the shaft and housing, SKF supplies both single and double direction thrust ball bearings with sphered seat surfaces on the housing washers (→ **fig. 3**). They can be used together with a sphered seat washer adjacent to the housing washer (→ **figs. 4 and 5**) or adjacent to a machine component manufactured with a sphered surface.

Appropriate sphered seat washers must be ordered separately (→ **product tables**). Depending on the bearing series, they have the basic designation U 2, U 3 or U 4 followed by a two-digit number, which identifies the size (e.g. sphered seat washer U 320 for bearing 53320).

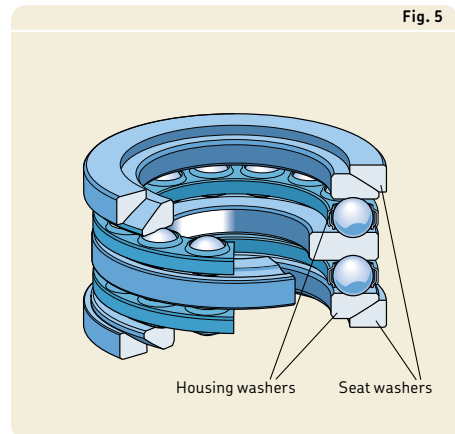
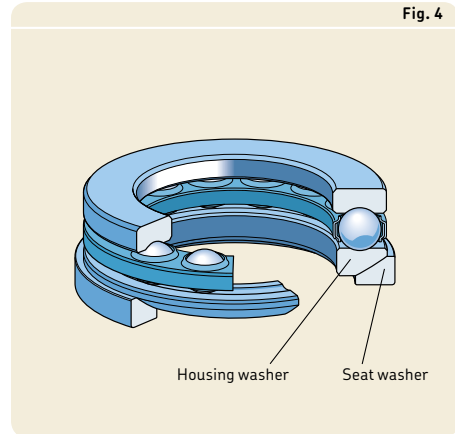
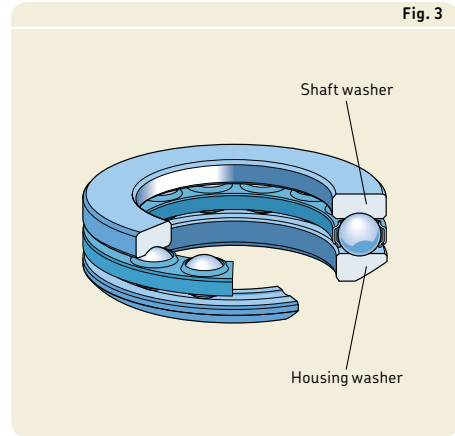
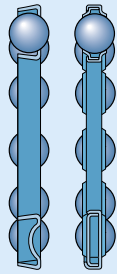

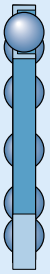

Table 1

Cages for thrust ball bearings

			
Cage description	Stamped steel, ball centred	Machined brass, ball centred	Machined steel, ball centred
Suffix	-	M	F

Bearing data

	Thrust ball bearings	
	with flat housing washers	with sphered housing washer(s)
Dimension standards	ISO 104 Bearings in the BA series are not standardized.	ISO 20516
Tolerances	Normal P5 or P6 on request (single direction bearings only)	Normal
For additional information (→ page 132)	Values: ISO 199 (→ table 10, page 144) Bearings in the BA series are not standardized.	
Misalignment	–	Accommodate initial misalignment between the support surfaces in the housing and on the shaft.
Friction, starting torque, power loss	Frictional moment, starting torque, and power loss can be calculated as specified under <i>Friction</i> (→ page 97), or using the tools available online at skf.com/bearingcalculator .	
Defect frequencies	Defect frequencies can be calculated using the tools available online at skf.com/bearingcalculator .	

Loads		Symbols
<p>Minimum load</p> <p>For additional information (→ page 86)</p>	$F_{am} = A \left(\frac{n}{1\,000} \right)^2$ <p>The weight of the components supported by the bearing, particularly when the shaft is vertical, together with external forces, generally exceed the requisite minimum load. If this is not the case, the bearing must be subjected to an additional axial load, e.g. by springs.</p>	<p>A = minimum load factor (→ product tables)</p> <p>F_a = axial load [kN]</p> <p>F_{am} = minimum axial load [kN]</p> <p>n = rotational speed [r/min]</p> <p>P = equivalent dynamic bearing load [kN]</p> <p>P_0 = equivalent static bearing load [kN]</p>
<p>Equivalent dynamic bearing load</p> <p>For additional information (→ page 85)</p>	$P = F_a$	
<p>Equivalent static bearing load</p> <p>For additional information (→ page 88)</p>	$P_0 = F_a$	

Temperature limits

The permissible operating temperature for thrust ball bearings can be limited by:

- the dimensional stability of the bearing washers and balls
- the cage
- the seat washer(s)
- the lubricant

When temperatures outside the permissible range are expected, contact the SKF application engineering service.

Bearing washers and balls

The washers and balls of SKF thrust ball bearings undergo a special heat treatment. Depending on their size they are heat stabilized up to:

- 125 °C (260 °F) when $d \leq 300$ mm
- 150 °C (300 °F) when $d > 300$ mm

Cages

Steel and brass cages can be used at the same operating temperatures as the bearing washers and balls.

Seat washers

Seat washers are made of steel and can be used at the same operating temperatures as the bearing washers and balls.

Lubricants

Temperature limits for SKF greases are provided under *Lubrication* (→ **page 239**). When using lubricants not supplied by SKF, the temperature limits should be evaluated according to the SKF traffic light concept (→ **page 244**).

Permissible speed

The permissible speed can be estimated using the speed ratings listed in the product tables and applying the information provided under *Speeds* (→ **page 117**).

Mounting

When installing a single direction thrust ball bearing it is important to differentiate between the shaft washer and the housing washer. The bore of the shaft washer is ground and always smaller than the bore of the housing washer. The shaft washer should always be placed against a shaft step or fixed shaft component.

Designation system

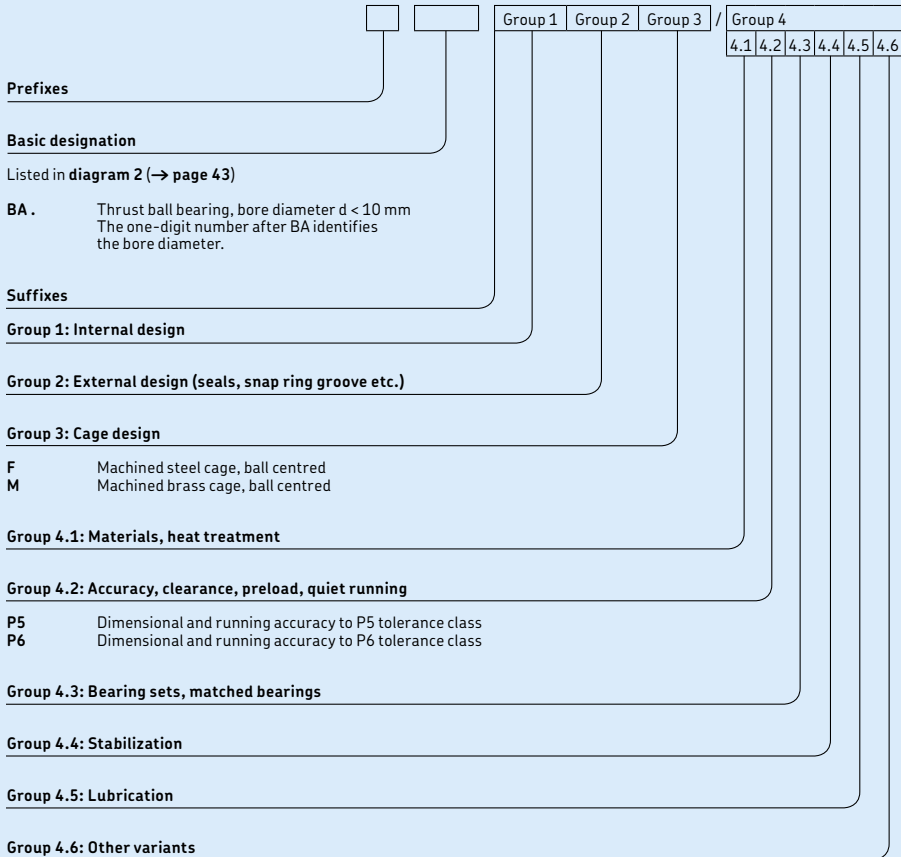

10.1 Single direction thrust ball bearings

d 3 – 30 mm

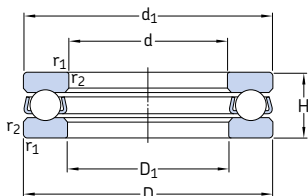

Principal dimensions			Basic load ratings		Fatigue load limit	Minimum load factor	Speed ratings		Mass	Designation
d	D	H	C	C_0			Reference speed	Limiting speed		
mm			kN		kN	–	r/min		kg	–
3	8	3,5	0,806	0,72	0,027	0,000 003	26 000	36 000	0,0009	BA 3
4	10	4	0,761	0,72	0,027	0,000 003	22 000	30 000	0,0015	BA 4
5	12	4	0,852	0,965	0,036	0,000 005	20 000	28 000	0,0021	BA 5
6	14	5	1,78	1,92	0,071	0,000 019	17 000	24 000	0,0035	BA 6
7	17	6	2,51	2,9	0,108	0,000 044	14 000	19 000	0,0065	BA 7
8	19	7	3,19	3,8	0,143	0,000 075	12 000	17 000	0,0091	BA 8
9	20	7	3,12	3,8	0,143	0,000 075	12 000	16 000	0,01	BA 9
10	24	9	9,95	15,3	0,56	0,0012	9 500	13 000	0,02	51100
	26	11	12,7	18,6	0,695	0,0018	8 000	11 000	0,03	51200
12	26	9	10,4	16,6	0,62	0,0014	9 000	13 000	0,022	51101
	28	11	13,3	20,8	0,765	0,0022	8 000	11 000	0,034	51201
15	28	9	10,6	18,3	0,67	0,0017	8 500	12 000	0,023	51102
	32	12	15,9	25	0,915	0,0038	7 000	10 000	0,046	51202
17	30	9	11,4	21,2	0,78	0,0023	8 500	12 000	0,025	51103
	35	12	16,3	27	1	0,0047	6 700	9 500	0,053	51203
20	35	10	15,1	29	1,08	0,0044	7 500	10 000	0,037	51104
	40	14	21,2	37,5	1,4	0,0085	6 000	8 000	0,083	51204
25	42	11	18,2	39	1,43	0,0079	6 300	9 000	0,056	51105
	47	15	26,5	50	1,86	0,015	5 300	7 500	0,11	51205
	52	18	34,5	60	2,24	0,018	4 500	6 300	0,17	51305
	60	24	42,3	67	2,45	0,048	3 600	5 000	0,34	51405
30	47	11	19	43	1,6	0,0096	6 000	8 500	0,063	51106
	52	16	25,1	51	1,86	0,013	4 800	6 700	0,13	51206
	60	21	35,8	65,5	2,4	0,026	3 800	5 300	0,26	51306
	70	28	70,2	122	4,5	0,097	3 000	4 300	0,52	51406

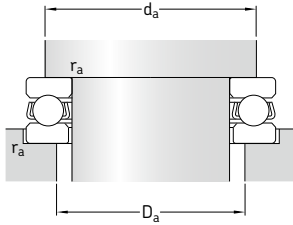

Dimensions

Abutment and fillet dimensions

d	d_1 ~	D_1 ~	$r_{1,2}$ min.	d_a min.	D_a max.	r_a max.
mm				mm		
3	7,8	3,2	0,15	5,8	5	0,15
4	9,8	4,2	0,15	7,5	6,5	0,15
5	11,8	5,2	0,15	8	9	0,15
6	13,8	6,2	0,2	11	9,5	0,2
7	16,8	7,2	0,2	12,5	11	0,2
8	18,8	8,2	0,3	14,5	12,5	0,3
9	19,8	9,2	0,3	15,5	13,5	0,3
10	24 26	11 12	0,3 0,6	19 20	15 16	0,3 0,6
12	26 28	13 14	0,3 0,6	21 22	17 18	0,3 0,6
15	28 32	16 17	0,3 0,6	23 25	20 22	0,3 0,6
17	30 35	18 19	0,3 0,6	25 28	22 24	0,3 0,6
20	35 40	21 22	0,3 0,6	29 32	26 28	0,3 0,6
25	42 47 52 60	26 27 27 27	0,6 0,6 1 1	35 38 41 46	32 34 36 39	0,6 0,6 1 1
30	47 52 60 70	32 32 32 32	0,6 0,6 1 1	40 43 48 54	37 39 42 46	0,6 0,6 1 1

10.1

10.1 Single direction thrust ball bearings

d 35 – 70 mm

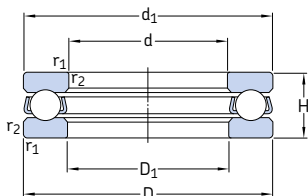

Principal dimensions			Basic load ratings		Fatigue load limit	Minimum load factor	Speed ratings		Mass	Designation
d	D	H	dynamic	static			Reference speed	Limiting speed		
mm	mm	mm	C	C ₀	P _u	A	r/min	r/min	kg	-
35	52	12	19,9	51	1,86	0,013	5 600	7 500	0,08	51107
	62	18	35,1	73,5	2,7	0,028	4 000	5 600	0,22	51207
	68	24	49,4	96,5	3,55	0,048	3 400	4 800	0,39	51307
	90	32	76,1	137	5,1	0,15	2 600	3 600	0,79	51407
40	60	13	25,5	63	2,32	0,02	5 000	7 000	0,12	51108
	68	19	44,2	96,5	3,6	0,058	3 800	5 300	0,28	51208
	78	26	61,8	122	4,5	0,077	3 000	4 300	0,53	51308
	90	36	95,6	183	6,8	0,26	2 400	3 400	1,1	51408
45	65	14	26,5	69,5	2,55	0,025	4 500	6 300	0,14	51109
	73	20	39	86,5	3,2	0,038	3 600	5 000	0,3	51209
	85	28	76,1	153	5,6	0,12	2 800	4 000	0,66	51309
	100	39	124	240	9	0,37	2 200	3 000	1,4	51409
50	70	14	27	75	2,8	0,029	4 300	6 300	0,16	51110
	78	22	49,4	116	4,3	0,069	3 400	4 500	0,37	51210
	95	31	81,9	170	6,3	0,19	2 600	3 600	0,94	51310
	110	43	159	340	12,5	0,6	2 000	2 800	2	51410
55	78	16	30,2	81,5	3	0,039	3 800	5 300	0,23	51111
	90	25	58,5	134	4,9	0,11	2 800	4 000	0,59	51211
	105	35	101	224	8,3	0,26	2 200	3 200	1,3	51311
	120	48	195	400	14,6	0,79	1 800	2 400	2,55	51411
60	85	17	41,6	122	4,55	0,077	3 600	5 000	0,27	51112
	95	26	59,2	140	5,1	0,12	2 800	3 800	0,65	51212
	110	35	101	224	8,3	0,26	2 200	3 000	1,35	51312
	130	51	199	430	16	0,96	1 600	2 200	3,1	51412 M
65	90	18	37,7	108	4	0,06	3 400	4 800	0,33	51113
	100	27	60,5	150	5,5	0,14	2 600	3 600	0,72	51213
	115	36	106	240	8,8	0,3	2 000	3 000	1,5	51313
	140	56	216	490	18	1,2	1 500	2 200	4	51413 M
70	95	18	40,3	120	4,4	0,074	3 400	4 500	0,35	51114
	105	27	62,4	160	5,85	0,16	2 600	3 600	0,79	51214
	125	40	135	320	11,8	0,53	1 900	2 600	2	51314
	150	60	234	550	19,3	1,6	1 400	2 000	5	51414 M

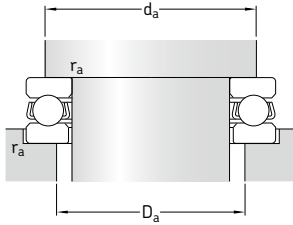

Dimensions

Abutment and fillet dimensions

d	d_1 ~	D_1 ~	$r_{1,2}$ min.	d_a min.	D_a max.	r_a max.
mm						
35	52	37	0,6	45	42	0,6
	62	37	1	51	46	1
	68	37	1	55	48	1
	80	37	1,1	62	53	1
40	60	42	0,6	52	48	0,6
	68	42	1	57	51	1
	78	42	1	63	55	1
	90	42	1,1	70	60	1
45	65	47	0,6	57	53	0,6
	73	47	1	62	56	1
	85	47	1	69	61	1
	100	47	1,1	78	67	1
50	70	52	0,6	62	58	0,6
	78	52	1	67	61	1
	95	52	1,1	77	68	1
	110	52	1,5	86	74	1,5
55	78	57	0,6	69	64	0,6
	90	57	1	76	69	1
	105	57	1,1	85	75	1
	120	57	1,5	94	81	1,5
60	85	62	1	75	70	1
	95	62	1	81	74	1
	110	62	1,1	90	80	1
	130	62	1,5	102	88	1,5
65	90	67	1	80	75	1
	100	67	1	86	79	1
	115	67	1,1	95	85	1
	140	68	2	110	95	2
70	95	72	1	85	80	1
	105	72	1	91	84	1
	125	72	1,1	103	92	1
	150	73	2	118	102	2

10.1

10.1 Single direction thrust ball bearings

d 75 – 130 mm

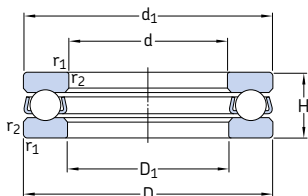

Principal dimensions			Basic load ratings		Fatigue load limit	Minimum load factor	Speed ratings		Mass	Designation
d	D	H	C	C ₀			Reference speed	Limiting speed		
mm			kN		kN	–	r/min		kg	–
75	100	19	44,2	134	4,9	0,11	3 200	4 300	0,4	51115
	110	27	63,7	170	6,2	0,17	2 400	3 400	0,83	51215
	135	44	163	390	14	0,79	1 700	2 400	2,6	51315
	160	65	251	610	20,8	1,9	1 300	1 800	6,75	51415 M
80	105	19	44,9	140	5,1	0,12	3 000	4 300	0,42	51116
	115	28	76,1	208	7,65	0,22	2 400	3 400	0,91	51216
	140	44	159	390	13,7	0,79	1 700	2 400	2,7	51316
	170	68	302	750	25	2,3	1 200	1 700	7,95	51416 M
85	110	19	44,9	146	5,4	0,14	3 000	4 300	0,44	51117
	125	31	97,5	275	9,8	0,39	2 200	3 000	1,2	51217
	150	49	174	405	14	1,1	1 600	2 200	3,55	51317
	180	72	286	750	24	2,9	1 200	1 600	9,45	51417 M
90	120	22	59,2	208	7,5	0,22	2 600	3 800	0,67	51118
	135	35	112	290	10,4	0,55	2 000	2 800	1,7	51218
	155	50	182	440	14,6	1,3	1 500	2 200	3,8	51318
	190	77	307	815	25,5	3,5	1 100	1 500	11	51418 M
100	135	25	80,6	265	9,15	0,44	2 400	3 200	0,97	51120
	150	38	119	325	10,8	0,62	1 800	2 400	2,2	51220
	170	55	225	570	18,3	1,9	1 400	1 900	4,95	51320
	210	85	371	1 060	31,5	5,8	950	1 400	15	51420 M
110	145	25	83,2	285	9,5	0,52	2 200	3 200	1,05	51122
	160	38	125	365	11,6	0,79	1 700	2 400	2,4	51222
	190	63,5	281	815	24,5	3,2	1 200	1 700	7,85	51322 M
	230	95	410	1 220	34,5	7,7	900	1 300	20	51422 M
120	155	25	85,2	305	9,65	0,58	2 200	3 000	1,15	51124
	170	39	127	390	11,8	1	1 600	2 200	2,65	51224
	210	70	325	980	28,5	5	1 100	1 500	11	51324 M
	250	102	432	1 320	36	16	800	1 100	25,5	51424 M
130	170	30	119	440	13,4	0,94	1 900	2 600	1,85	51126
	190	45	186	585	17	1,8	1 400	2 000	4	51226
	225	75	358	1 140	32	6,8	1 000	1 400	13	51326 M
	270	110	520	1 730	45	16	750	1 000	32	51426 M

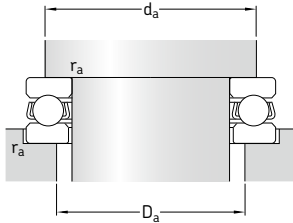

Dimensions

Abutment and fillet dimensions

d	d_1 ~	D_1 ~	$r_{1,2}$ min.	d_a min.	D_a max.	r_a max.
mm				mm		
75	100	77	1	90	85	1
	110	77	1	96	89	1
	135	77	1,5	111	99	1,5
	160	78	2	126	109	2
80	105	82	1	95	90	1
	115	82	1	101	94	1
	140	82	1,5	116	104	1,5
	170	83	2,1	133	117	2
85	110	87	1	100	95	1
	125	88	1	109	101	1
	150	88	1,5	124	111	1,5
	177	88	2,1	141	124	2
90	120	92	1	108	102	1
	135	93	1,1	117	108	1
	155	93	1,5	129	116	1,5
	187	93	2,1	149	131	2
100	135	102	1	121	114	1
	150	103	1,1	130	120	1
	170	103	1,5	142	128	1,5
	205	103	3	165	145	2,5
110	145	112	1	131	124	1
	160	113	1,1	140	130	1
	187	113	2	158	142	2
	225	113	3	181	159	2,5
120	155	122	1	141	134	1
	170	123	1,1	150	140	1
	205	123	2,1	173	157	2
	245	123	4	197	173	3
130	170	132	1	154	146	1
	187	133	1,5	166	154	1,5
	220	134	2,1	186	169	2
	265	134	4	213	187	3

10.1

10.1 Single direction thrust ball bearings d 140 – 280 mm

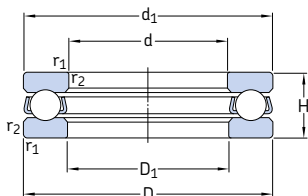

Principal dimensions			Basic load ratings		Fatigue load limit	Minimum load factor	Speed ratings		Mass	Designation
d	D	H	C	C ₀			Reference speed	Limiting speed		
mm			kN		kN	–	r/min		kg	–
140	180	31	111	440	12,9	1	1 800	2 600	2,05	51128
	200	46	190	620	17,6	2	1 400	1 900	4,35	51228
	240	80	377	1 220	32,5	9,1	950	1 300	15,5	51328 M
	280	112	520	1 730	44	16	700	1 000	34,5	51428 M
150	190	31	111	440	12,5	1	1 700	2 400	2,2	51130 M
	215	50	238	800	22	3,3	1 300	1 800	6,1	51230 M
	250	80	390	1 290	34	10	900	1 300	16,5	51330 M
	300	120	559	1 960	48	20	670	950	42,5	51430 M
160	200	31	112	465	12,9	1,1	1 700	2 400	2,35	51132 M
	225	51	238	830	22,4	3,8	1 200	1 700	6,55	51232 M
	270	87	449	1 660	41,5	14	850	1 200	21	51332 M
170	215	34	133	540	14,3	1,5	1 600	2 200	3,3	51134 M
	240	51	270	930	24	5,4	1 200	1 700	8,15	51234 M
	280	87	468	1 760	43	16	800	1 100	22	51334 M
180	225	34	135	570	15	1,7	1 500	2 200	3,5	51136 M
	250	51	302	1 120	28,5	6,1	1 200	1 600	8,6	51236 M
	300	95	520	2 000	47,5	21	750	1 100	28,5	51336 M
190	240	37	172	710	18	2,6	1 400	2 000	4,05	51138 M
	270	51	332	1 270	31	8,4	1 100	1 600	12	51238 M
	320	105	559	2 200	51	30	700	950	36,5	51338 M
200	250	37	168	710	17,6	2,6	1 400	1 900	4,25	51140 M
	280	51	338	1 320	31,5	9,1	1 100	1 500	12	51240 M
	340	110	624	2 600	58,5	35	630	900	44,5	51340 M
220	270	37	178	800	19	3,3	1 300	1 900	4,6	51144 M
	300	63	358	1 460	33,5	11	950	1 300	13	51244 M
240	300	45	234	1 040	23,6	5,6	1 100	1 600	7,55	51148 M
	340	78	449	1 960	42,5	21	800	1 100	23	51248 M
260	320	45	238	1 100	24	6,3	1 100	1 500	8,1	51152 M
	360	79	488	2 240	46,5	24	750	1 100	25	51252 M
280	350	53	319	1 460	30,5	11	950	1 300	12	51156 M
	380	80	488	2 320	47,5	28	750	1 000	26,5	51256 M

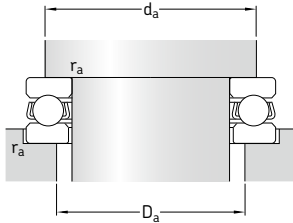

Dimensions

Abutment and fillet dimensions

d	d_1 ~	D_1 ~	$r_{1,2}$ min.	d_a min.	D_a max.	r_a max.
mm						
140	178	142	1	164	156	1
	197	143	1,5	176	164	1,5
	235	144	2,1	199	181	2
	275	144	4	223	197	3
150	188	152	1	174	166	1
	212	153	1,5	189	176	1,5
	245	154	2,1	209	191	2
	295	154	4	239	211	3
160	198	162	1	184	176	1
	222	163	1,5	199	186	1,5
	265	164	3	225	205	2,5
170	213	172	1,1	197	188	1
	237	173	1,5	212	198	1,5
	275	174	3	235	215	2,5
180	222	183	1,1	207	198	1
	245	183	1,5	222	208	1,5
	295	184	3	251	229	2,5
190	237	193	1,1	220	210	1
	265	194	2	238	222	2
	315	195	4	267	243	3
200	247	203	1,1	230	220	1
	275	204	2	248	232	2
	335	205	4	283	257	3
220	267	223	1,1	250	240	1
	295	224	2	268	252	2
240	297	243	1,5	276	264	1,5
	335	244	2,1	299	281	2
260	317	263	1,5	296	284	1,5
	355	264	2,1	319	301	2
280	347	283	1,5	322	308	1,5
	375	284	2,1	339	321	2

10.1

10.1 Single direction thrust ball bearings

d 300 – 670 mm

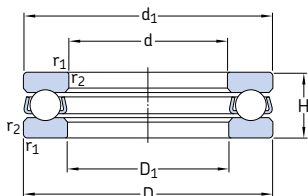

Principal dimensions			Basic load ratings		Fatigue load limit	Minimum load factor	Speed ratings		Mass	Designation
d	D	H	C	C ₀			Reference speed	Limiting speed		
mm			kN		kN	–	r/min		kg	–
300	380	62	364	1 760	35,5	16	850	1 200	17,5	51160 M
	420	95	585	3 000	57	47	630	850	42	51260 M
320	400	63	371	1 860	36,5	18	800	1 100	19	51164 M
	440	95	572	3 000	56	47	600	800	45,5	51264 F
340	420	64	377	1 960	37,5	20	800	1 100	20,5	51168 M
	460	96	605	3 200	58,5	53	530	750	48,5	51268 F
360	440	65	390	2 080	38	22	750	1 000	22	51172 F
	500	110	741	4 150	73,5	90	500	700	70	51272 F
380	460	65	397	2 200	40	25	750	1 000	23	51176 F
	520	112	728	4 150	72	90	500	700	73	51276 F
400	480	65	403	2 280	40,5	27	700	1 000	24	51180 F
420	500	65	410	2 400	41,5	30	700	1 000	25,5	51184 F
440	540	80	527	3 250	55	55	600	850	42	51188 F
460	560	80	527	3 250	54	55	600	800	43,5	51192 F
480	580	80	540	3 550	56	66	560	800	45,5	51196 F
500	600	80	553	3 600	57	67	560	800	47	511/500 F
530	640	85	650	4 400	68	100	530	750	58,5	511/530 F
560	670	85	650	4 650	68	110	500	700	61	511/560 F
600	710	85	663	4 800	69,5	120	500	700	65	511/600 F
630	750	95	728	5 400	76,5	150	450	630	84	511/630 F
670	800	105	852	6 700	91,5	230	400	560	105	511/670 F

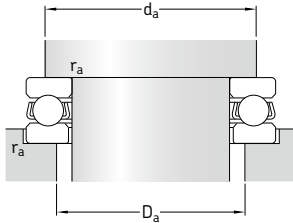

Dimensions

Abutment and fillet dimensions

d	d_1 ~	D_1 ~	$r_{1,2}$ min.	d_a min.	D_a max.	r_a max.
mm				mm		
300	376	304	2	348	332	2
	415	304	3	371	349	2,5
320	396	324	2	368	352	2
	435	325	3	391	369	2,5
340	416	344	2	388	372	2
	455	345	3	411	389	2,5
360	436	364	2	408	392	2
	495	365	4	443	417	3
380	456	384	2	428	412	2
	515	385	4	463	437	3
400	476	404	2	448	432	2
420	496	424	2	468	452	2
440	536	444	2,1	499	481	2
460	556	464	2,1	519	501	2
480	576	484	2,1	539	521	2
500	596	504	2,1	559	541	2
530	636	534	3	595	575	2,5
560	666	564	3	625	606	2,5
600	706	604	3	665	645	2,5
630	746	634	3	701	679	2,5
670	795	675	4	747	723	3

10.1

10.2 Single direction thrust ball bearings with a sphered housing washer d 12 – 70 mm

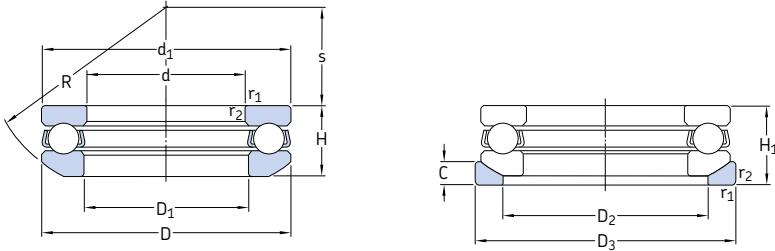

Principal dimensions			Basic load ratings		Fatigue load limit	Minimum load factor	Speed ratings		Mass	Designations	Seat washer
d	D	H ₁	dynamic C	static C ₀	P _u	A	Reference speed	Limiting speed	Bearing incl. washer	Bearing	
mm			kN		kN	-	r/min		kg	-	
12	28	13	13,3	20,8	0,765	0,0022	8 000	11 000	0,045	53201	U 201
15	32	15	15,9	25	0,915	0,0038	7 000	10 000	0,063	53202	U 202
17	35	15	16,3	27	1	0,0047	6 700	9 500	0,071	53203	U 203
20	40	17	21,2	37,5	1,4	0,0085	5 600	8 000	0,1	53204	U 204
25	47	19	26,5	50	1,86	0,015	5 000	7 000	0,15	53205	U 205
30	52	20	25,1	51	1,86	0,013	4 500	6 300	0,18	53206	U 206
	60	25	35,8	65,5	2,4	0,026	3 800	5 300	0,33	53306	U 306
35	62	22	35,1	73,5	2,7	0,028	4 000	5 600	0,28	53207	U 207
	68	28	49,4	96,5	3,55	0,048	3 200	4 500	0,46	53307	U 307
40	68	23	44,2	96,5	3,6	0,058	3 600	5 300	0,35	53208	U 208
	78	31	61,8	122	4,5	0,077	2 800	4 000	0,67	53308	U 308
	90	42	95,6	183	6,8	0,26	2 400	3 200	1,35	53408	U 408
45	73	24	39	86,5	3,2	0,038	3 400	4 800	0,39	53209	U 209
	85	33	76,1	153	5,6	0,12	2 600	3 800	0,83	53309	U 309
50	78	26	49,4	116	4,3	0,069	3 200	4 500	0,47	53210	U 210
	95	37	81,9	170	6,3	0,19	2 400	3 400	1,2	53310	U 310
	110	50	159	340	12,5	0,6	1 900	2 600	2,3	53410	U 410
55	90	30	58,5	134	4,9	0,11	2 800	3 800	0,75	53211	U 211
	105	42	101	224	8,3	0,26	2 200	3 000	1,7	53311	U 311
	120	55	195	400	14,6	0,79	1 700	2 400	3,1	53411	U 411
60	95	31	59,2	140	5,1	0,12	2 600	3 600	0,82	53212	U 212
	110	42	101	224	8,3	0,26	2 000	3 000	1,7	53312	U 312
	130	58	199	430	16	0,96	1 600	2 200	3,8	53412 M	U 412
65	100	32	60,5	150	5,5	0,14	2 600	3 600	0,91	53213	U 213
	115	43	106	240	8,8	0,3	2 000	2 800	1,9	53313	U 313
70	105	32	62,4	160	5,85	0,16	2 600	3 600	0,97	53214	U 214
	125	48	135	320	11,8	0,53	1 800	2 600	2,5	53314	U 314
	150	69	234	550	19,3	1,6	1 400	2 000	6,5	53414 M	U 414

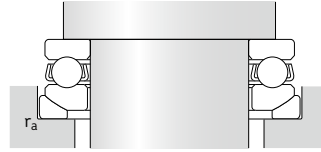
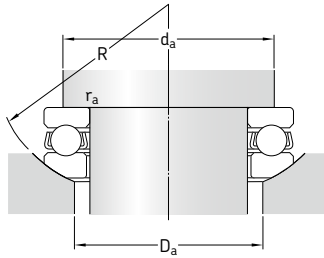

Dimensions

Abutment and fillet dimensions

d	d ₁	D ₁	D ₂	D ₃	H	C	R	s	r _{1,2} min.	d _a min.	D _a max.	r _a max.
mm										mm		
12	28	14	20	30	11,4	3,5	25	11,5	0,6	22	20	0,6
15	32	17	24	35	13,3	4	28	12	0,6	25	24	0,6
17	35	19	26	38	13,2	4	32	16	0,6	28	24	0,6
20	40	22	30	42	14,7	5	36	18	0,6	32	30	0,6
25	47	27	36	50	16,7	5,5	40	19	0,6	38	36	0,6
30	52	32	42	55	17,8	5,5	45	22	0,6	43	42	0,6
	60	32	45	62	22,6	7	50	22	1	48	45	1
35	62	37	48	65	19,9	7	50	24	1	51	48	1
	68	37	52	72	25,6	7,5	56	24	1	55	52	1
40	68	42	55	72	20,3	7	56	28,5	1	57	55	1
	78	42	60	82	28,5	8,5	64	28	1	63	60	1
	90	42	65	95	38,2	12	72	26	1,1	70	65	1
45	73	47	60	78	21,3	7,5	56	26	1	62	60	1
	85	47	65	90	30,1	10	64	25	1	69	65	1
50	78	52	62	82	23,5	7,5	64	32,5	1	67	62	1
	95	52	72	100	34,3	11	72	28	1,1	77	72	1
	110	52	80	115	45,6	14	90	35	1,5	86	65	1,5
55	90	57	72	95	27,3	9	72	35	1	76	72	1
	105	57	80	110	39,3	11,5	80	30	1,1	85	80	1
	120	57	88	125	50,5	15,5	90	28	1,5	94	88	1,5
60	95	62	78	100	28	9	72	32,5	1	81	78	1
	110	62	85	115	38,3	11,5	90	41	1,1	90	85	1
	130	62	95	135	54	16	100	34	1,5	102	95	1
65	100	67	82	105	28,7	9	80	40	1	86	82	1
	115	67	90	120	39,4	12,5	90	38,5	1,1	95	90	1
70	105	72	88	110	27	9	80	38	1	91	88	1
	125	72	98	130	44,2	13	100	43	1,1	103	98	1
	150	73	110	155	63,6	19,5	112	34	2	118	110	2

10.2 Single direction thrust ball bearings with a sphered housing washer d 75 – 140 mm

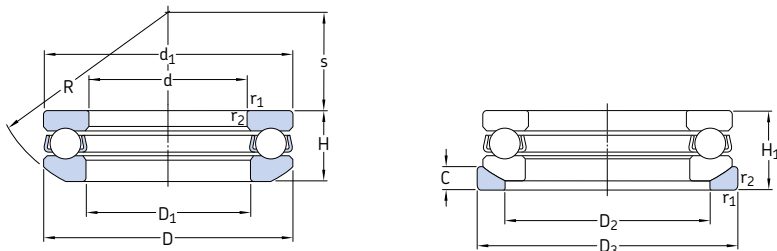

Principal dimensions			Basic load ratings		Fatigue load limit	Minimum load factor	Speed ratings		Mass	Designations	Seat washer
d	D	H ₁	dynamic C	static C ₀	P _u	A	Reference speed	Limiting speed	Bearing incl. washer	Bearing	
mm			kN		kN	-	r/min		kg	-	
75	110	32	63,7	170	6,2	0,17	2 400	3 400	1	53215	U 215
	135	52	163	390	14	0,79	1 700	2 400	3,2	53315	U 315
	160	75	251	610	20,8	1,9	1 300	1 800	8,1	53415 M	U 415
80	115	33	76,1	208	7,65	0,22	2 400	3 200	1,1	53216	U 216
	140	52	159	390	13,7	0,79	1 600	2 200	3,2	53316	U 316
85	125	37	97,5	275	9	0,39	2 000	3 000	1,5	53217	U 217
	150	58	174	405	14	1,1	1 500	2 000	4,35	53317	U 317
90	135	42	112	290	10,4	0,55	1 900	2 600	2,1	53218	U 218
	155	59	182	440	14,6	1,3	1 400	2 000	4,7	53318	U 318
	190	88	307	815	25,5	3,5	1 100	1 500	13	53418 M	U 418
100	150	45	119	325	10,8	0,62	1 700	2 400	2,7	53220	U 220
	170	64	225	570	18,3	1,9	1 300	1 800	5,95	53320	U 320
	210	98	371	1 060	31,5	5,8	950	1 300	18	53420 M	U 420
110	160	45	125	365	11,6	0,79	1 700	2 400	2,9	53222	U 222
	190	72	281	815	24,5	3,2	1 100	1 600	9,1	53322 M	U 322
120	170	46	127	390	11,8	1	1 500	2 200	3,2	53224	U 224
	210	80	325	980	28,5	5	1 000	1 400	12,5	53324 M	U 324
130	190	53	186	585	17	1,8	1 300	1 800	4,85	53226	U 226
140	200	55	190	620	17,6	2	1 300	1 800	5,45	53228	U 228

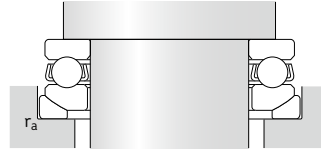
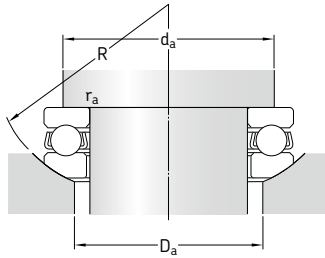

Dimensions

Abutment and fillet dimensions

d	d ₁	D ₁	D ₂	D ₃	H	C	R	s	r _{1,2} min.	d _a min.	D _a max.	r _a max.
mm										mm		
75	110	77	92	115	28,3	9,5	90	49	1	96	92	1
	135	77	105	140	48,1	15	100	37	1,5	111	105	1
	160	78	115	165	69	21	125	42	2	126	115	2
80	115	82	98	120	29,5	10	90	46	1	101	98	1
	140	82	110	145	47,6	15	112	50	1,5	116	110	1
85	125	88	105	130	33,1	11	100	52	1	109	105	1
	150	88	115	155	53,1	17,5	112	43	1,5	124	115	1
90	135	93	110	140	38,5	13,5	100	45	1,1	117	110	1
	155	93	120	160	54,6	18	112	40	1,5	129	120	1
	187	93	140	195	81,2	25,5	140	40	2,1	133	125	2
100	150	103	125	155	40,9	14	112	52	1,1	130	125	1
	170	103	135	175	59,2	18	125	46	1,5	142	135	1
	205	103	155	220	90	27	160	50	3	165	155	2
110	160	113	135	165	40,2	14	125	65	1,1	140	135	1
	187	113	150	195	67,2	20	140	51	2	140	158	1
120	170	123	145	175	40,8	15	125	61	1,1	150	145	1
	205	123	165	220	74,1	22	160	63	2,1	173	157	1
130	187	133	160	195	47,9	17	140	67	1,5	166	160	1
140	197	143	170	210	48,6	17	160	87	1,5	176	170	1

10.2

10.3 Double direction thrust ball bearings

d 10 – 60 mm

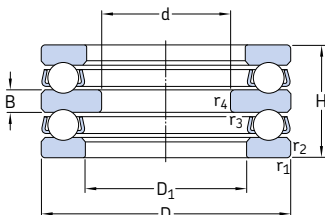

Principal dimensions			Basic load ratings		Fatigue load limit P_u	Minimum load factor A	Speed ratings		Mass	Designation
d	D	H	dynamic C	static C_0			Reference speed	Limiting speed		
mm			kN		kN	-	r/min		kg	-
10	32	22	15,9	25	1	0,0038	7 000	10 000	0,081	52202
15	40	26	21,2	37,5	1,4	0,0085	4 300	6 000	0,15	52204
20	47	28	26,5	50	1,86	0,015	3 800	5 300	0,22	52205
	52	34	34,5	60	2,24	0,018	3 200	4 500	0,33	52305
	70	52	70,2	122	4,5	0,097	2 200	3 200	1	52406
25	52	29	24,7	46,5	1,86	0,013	3 600	5 000	0,25	52206
	60	38	35,8	65,5	2,4	0,026	2 800	4 000	0,47	52306
	80	59	76,1	137	5,1	0,15	2 000	2 800	1,45	52407
30	62	34	35,1	73,5	2,7	0,028	3 000	4 300	0,41	52207
	68	36	44,2	96,5	3,6	0,058	2 800	3 800	0,55	52208
	68	44	49,4	96,5	3,55	0,048	2 400	3 400	0,68	52307
	78	49	61,8	122	4,5	0,077	2 200	3 000	1,05	52308
	90	65	95,6	183	6,8	0,26	1 800	2 400	2,05	52408
35	73	37	39	86,5	3,2	0,038	2 600	3 600	0,6	52209
	85	52	76,1	153	5,6	0,12	2 000	2 800	1,25	52309
	100	72	124	240	9	0,37	1 600	2 200	2,7	52409
40	78	39	49,4	116	4,3	0,069	2 400	3 400	0,71	52210
	95	58	81,9	170	6,3	0,19	1 800	2 600	1,75	52310
45	90	45	58,5	134	4,9	0,11	2 200	3 000	1,1	52211
	105	64	101	224	8,3	0,26	1 600	2 200	2,4	52311
	120	87	195	400	14,6	0,79	1 300	1 800	4,7	52411
50	95	46	59,2	140	5,1	0,12	2 000	2 800	1,2	52212
	110	64	101	224	8,3	0,26	1 600	2 200	2,55	52312
	130	93	199	430	16	0,96	1 200	1 700	6,35	52412 M
55	100	47	60,5	150	5,5	0,14	2 000	2 800	1,35	52213
	105	47	62,4	160	5,85	0,16	1 900	2 600	1,5	52214
	115	64	106	240	8,8	0,3	1 600	2 200	2,75	52313
	125	72	135	320	11,8	0,53	1 400	2 000	3,65	52314
	250	107	234	550	19,3	1,6	800	1 100	9,7	52414 M
60	110	47	63,7	170	6,2	0,17	1 900	2 600	1,55	52215
	135	79	163	390	14	0,79	1 300	1 800	4,8	52315

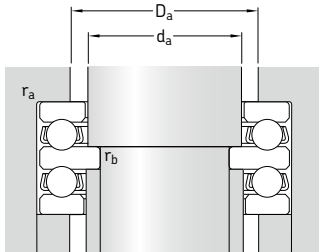

Dimensions

Abutment and fillet dimensions

d	D ₁ ~	B	r _{1,2} min.	r _{3,4} min.	d _a	D _a max.	r _a max.	r _b max.
mm					mm			
10	17	5	0,6	0,3	15	22	0,6	0,3
15	22	6	0,6	0,3	20	28	0,6	0,3
20	27	7	0,6	0,3	25	34	0,6	0,3
	27	8	1	0,3	25	36	1	0,3
	32	12	1	0,6	30	46	1	0,6
25	32	7	0,6	0,3	30	39	0,6	0,3
	32	9	1	0,3	30	42	1	0,3
	37	14	1,1	0,6	35	53	1	0,6
30	37	8	1	0,3	35	46	1	0,3
	42	9	1	0,6	40	51	1	0,6
	37	10	1	0,3	35	48	1	0,3
	42	12	1	0,6	40	55	1	0,6
	42	15	1,1	0,6	40	60	1	0,6
35	47	9	1	0,6	45	56	1	0,6
	47	12	1	0,6	46	61	1	0,6
	47	17	1,1	0,6	45	67	1	0,6
40	52	9	1	0,6	50	61	1	0,6
	52	14	1,1	0,6	50	68	1	0,6
45	57	10	1	0,6	55	69	1	0,6
	57	15	1,1	0,6	55	75	1	0,6
	57	20	1,5	0,6	55	81	1,5	0,6
50	62	10	1	0,6	60	74	1	0,6
	62	15	1,1	0,6	60	80	1	0,6
	62	21	1,5	0,6	60	88	1,5	0,6
55	67	10	1	0,6	65	79	1	0,6
	72	10	1	1	70	84	1	1
	67	15	1,1	0,6	65	85	1	0,6
	72	16	1,1	1	70	92	1	1
	73	24	2	1	70	120	1,5	1
60	77	10	1	1	75	89	1	1
	77	18	1,5	1	75	99	1,5	1

10.3 Double direction thrust ball bearings d 65 – 150 mm

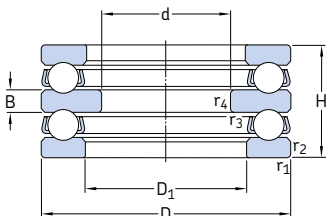

Principal dimensions			Basic load ratings		Fatigue load limit P_u	Minimum load factor A	Speed ratings		Mass	Designation
d	D	H	dynamic C	static C_0			Reference speed	Limiting speed		
mm			kN		kN	-	r/min		kg	-
65	115	48	76,1	208	7,65	0,22	2 400	3 400	1,7	52216
	140	79	159	390	13,7	0,79	1 300	1 800	4,95	52316
70	125	55	97,5	275	9,8	0,39	1 600	2 200	2,4	52217
75	135	62	112	290	11,6	0,55	1 500	2 000	3,2	52218
85	150	67	119	325	10,8	0,62	1 300	1 800	4,2	52220
	170	97	225	570	18,3	1,9	1 000	1 400	8,95	52320
95	160	67	125	365	11,6	0,79	1 300	1 800	4,65	52222
100	170	68	127	390	11,8	1	1 200	1 700	5,25	52224
110	190	80	186	585	17	1,8	1 400	2 000	8	52226
120	200	81	190	620	17,6	2	1 000	1 400	8,65	52228
130	215	89	238	800	22	3,3	950	1 300	11,5	52230 M
140	225	90	238	830	22,4	3,8	900	1 300	12	52232 M
150	240	97	270	930	24	5,4	850	1 200	15	52234 M
	250	98	302	1 120	28,5	6,1	800	1 100	16	52236 M

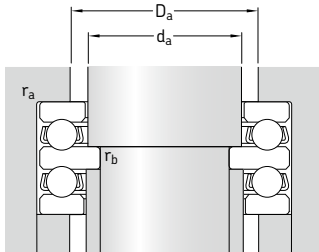

Dimensions

Abutment and fillet dimensions

d	D_1 ~	B	$r_{1,2}$ min.	$r_{3,4}$ min.	d_a	D_a max.	r_a max.	r_b max.
mm					mm			
65	82	10	1	1	80	94	1	1
	82	18	1,5	1	80	104	1	1
70	88	12	1	1	85	101	1	1
75	93	14	1,1	1	90	108	1	1
85	103	15	1,1	1	100	120	1	1
	103	21	1,5	1	100	128	1	1
95	113	15	1,1	1	110	130	1	1
100	123	15	1,1	1,1	120	140	1	1
110	133	18	1,5	1,1	130	154	1,5	1
120	143	18	1,5	1,1	140	164	1,5	1
130	153	20	1,5	1,1	120	140	1,5	1
140	163	20	1,5	1,1	120	140	1,5	1
150	173	21	1,5	1,1	120	140	1,5	1
	183	21	1,5	2	120	140	1,5	2

10.3

10.4 Double direction thrust ball bearings with sphered housing washers d 25 – 80 mm

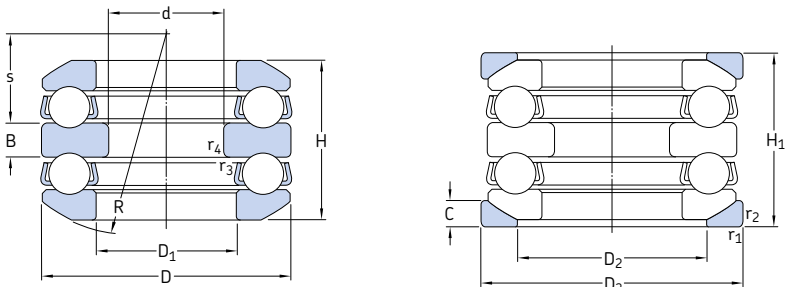

Principal dimensions			Basic load ratings		Fatigue load limit P_u	Minimum load factor A	Speed ratings		Mass Bearing incl. washer	Designations	
d	D	H_1	dynamic C	static C_0			Reference speed	Limiting speed		Bearing	Seat washer
mm			kN		kN		r/min		kg	-	-
25	60	46	35,8	65,5	2,4	0,026	2 800	3 800	0,58	54306	U 306
30	62	42	35,1	73,5	2,7	0,028	2 800	4 000	0,53	54207	U 207
	68	44	44,2	96,5	3,6	0,058	2 800	3 800	0,63	54208	U 208
	68	52	49,4	96,5	3,55	0,048	2 400	3 400	0,85	54307	U 307
	78	59	61,8	122	4,5	0,077	2 200	3 000	1,15	54308	U 308
35	73	45	39	86,5	3,2	0,038	2 600	3 600	0,78	54209	U 209
	85	62	76,1	153	5,6	0,12	1 900	2 800	1,6	54309	U 309
	100	86	124	240	9	0,37	1 500	2 000	3	54409	U 409
40	95	70	81,9	170	6,3	0,19	1 700	2 400	2,3	54310	U 310
	110	92	148	305	11,4	0,6	1 400	1 900	4,45	54410	U 410
45	90	55	58,5	134	4,9	0,11	2 200	3 000	1,3	54211	U 211
50	110	78	101	224	8,3	0,26	1 500	2 200	2,9	54312	U 312
65	140	95	159	390	13,7	0,79	1 300	1 800	5,55	54316	U 316
	170	140	307	750	25	2,3	850	1 200	17,5	54416 M	U 416
70	150	105	174	405	14	1,1	1 100	1 500	7,95	54317	U 317
80	210	176	371	1 060	31,5	5,8	700	950	29	54420 M	U 420

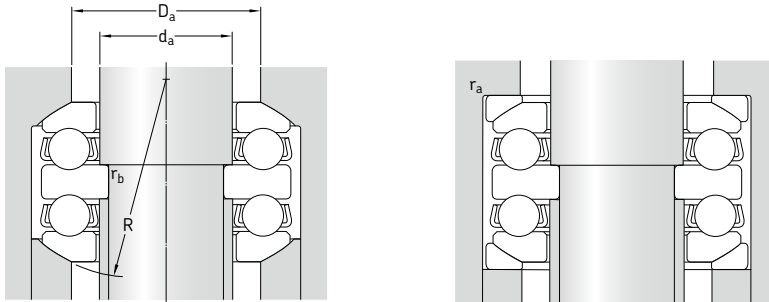

Dimensions

Abutment and fillet dimensions

d	D ₁	D ₂	D ₃	H	B	C	R	s	r _{1,2} min.	r _{3,4} min.	d _a	D _a max.	r _a max.	r _b max.
mm											mm			
25	32	45	62	41,3	9	7	50	19,5	1	0,3	30	45	1	0,3
30	37	48	65	37,8	8	7	50	21	1	0,3	35	48	1	0,3
	42	55	72	38,6	9	7	56	25	1	0,6	40	55	1	0,6
	37	52	72	47,2	10	7,5	56	21	1	0,3	35	52	1	0,3
35	42	60	82	54,1	12	8,5	64	23,5	1	0,6	40	60	1	0,6
	47	60	78	39,6	9	7,5	56	23	1	0,6	45	60	1	0,6
	47	65	90	56,2	12	10	64	21	1	0,6	45	65	1	0,6
40	47	72	105	78,9	17	12,5	80	23,5	1,1	0,6	45	72	1	0,6
	52	72	100	64,7	14	11	72	23	1,1	0,6	50	72	1	0,6
45	52	80	115	83,2	18	14	72	30	1,5	0,6	50	80	1,5	0,6
	57	72	95	49,6	10	9	72	32,5	1	0,6	55	72	1	0,6
50	62	85	115	70,7	15	11,5	90	36,5	1,1	0,6	60	85	1	0,6
65	82	110	145	86,1	18	15	112	45,5	1,5	1	80	110	1,5	1
	83	125	175	128,5	27	22	125	30,5	2,1	1	80	125	2	1
70	88	115	155	95,2	19	17,5	112	39	1,5	1	85	115	1,5	1
80	103	155	220	159,9	33	27	125	43,5	3	1,1	100	155	2,5	1

10.4

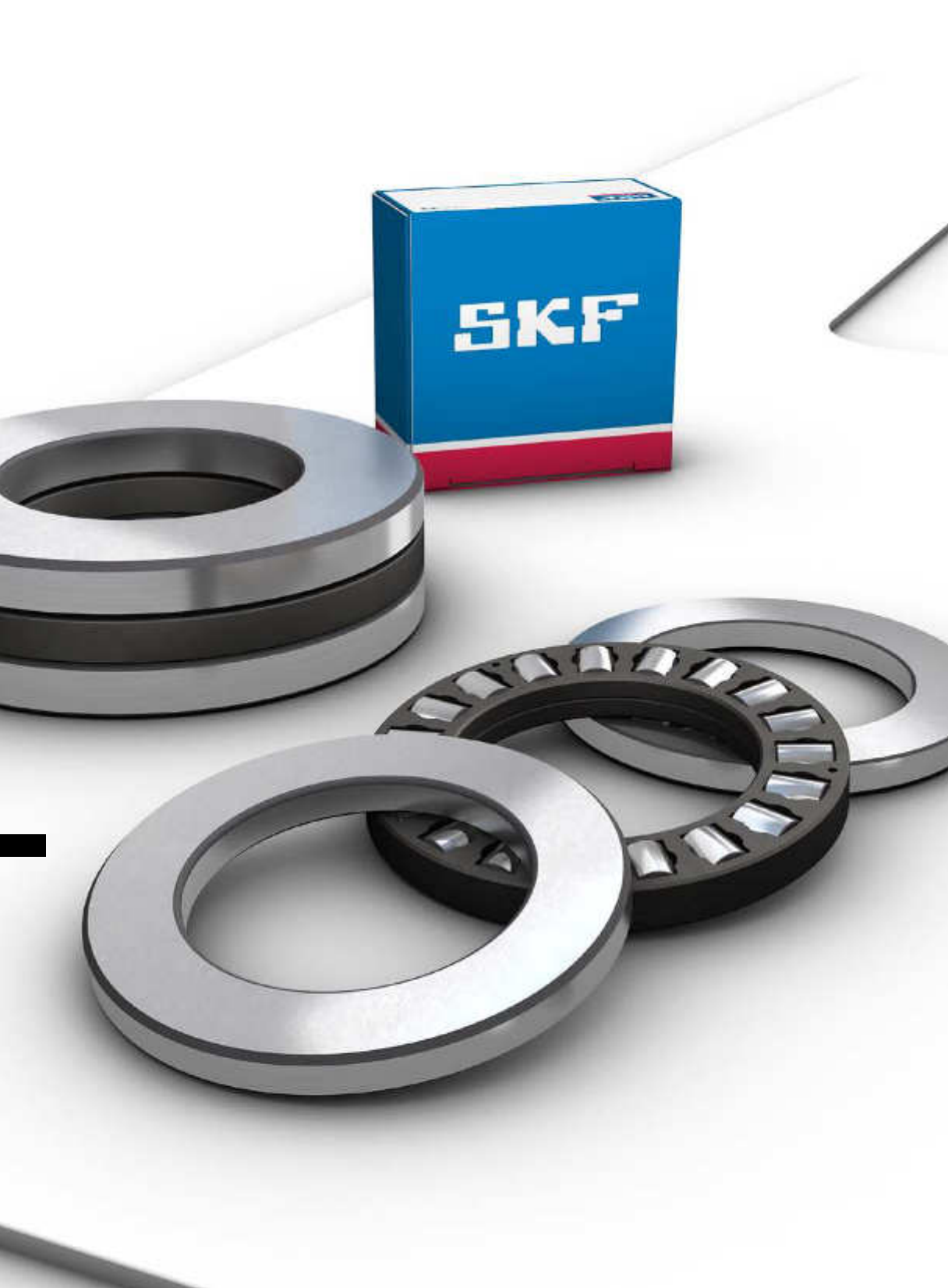

10 Cylindrical roller thrust bearings

Designs and variants	1038
Single direction cylindrical roller thrust bearings	1038
Double direction cylindrical roller thrust bearings	1038
Components	1039
Bearing washers.	1039
Cages.	1040

Bearing data	1041
(Dimension standards, tolerances, misalignment, friction, starting torque, power loss, defect frequencies)	

Loads	1044
(Minimum load, equivalent loads)	

Temperature limits	1045
-------------------------------------	-------------

Permissible speed	1045
------------------------------------	-------------

Design of bearing arrangements	1046
Abutment dimensions	1046
Raceways on shafts and in housings . . .	1046

Designation system	1047
-------------------------------------	-------------

Product table

11.1 Cylindrical roller thrust bearings	1048
--	-------------



11 Cylindrical roller thrust bearings

Designs and variants

SKF cylindrical roller thrust bearings are designed to accommodate heavy axial loads and shock loads. They must not be subjected to any radial load. The ends of the rollers are relieved slightly to modify the line contact between the raceways and rollers. This prevents stress peaks at the roller ends to extend bearing service life.

Cylindrical roller thrust bearings are very stiff and require little axial space. They are separable, that means that shaft washer, housing washer, and cylindrical roller and cage thrust assembly can be mounted separately.

Cylindrical roller thrust bearings are manufactured with one or two rows of rollers (→ fig. 1). Bearings in the 811 and 812 series are mainly used in applications where thrust ball bearings do not have sufficient load carrying capacity.

Single direction cylindrical roller thrust bearings

As standard, cylindrical roller thrust bearings are available as single direction bearings (→ fig. 1) and can accommodate axial loads in one direction only.

Double direction cylindrical roller thrust bearings

Double direction cylindrical roller thrust bearings can accommodate axial loads in both

More information

Bearing life and load ratings. 63

Design considerations 159

Abutment and fillet dimensions. 208

Lubrication 239

Mounting, dismantling and bearing care 271

Fig. 1

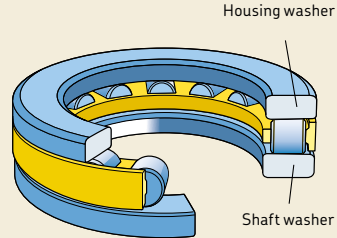

Single row bearing, 811 and 812 series

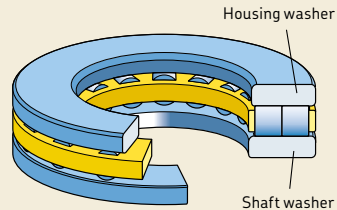

Double row bearing, 893 and 894 series

Fig. 2

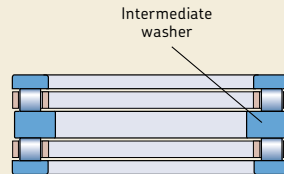

Shaft centred bearing

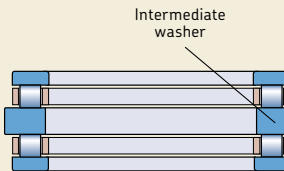

Housing centred bearing

directions. They can be created by combining two cylindrical roller and cage thrust assemblies and two bearing washers with an intermediate washer. Depending on the design, an intermediate washer can be shaft or housing centred (→ **fig. 2**).

Intermediate washers must have the same surface finish and hardness as bearing washers. SKF does not supply intermediate washers, but provides material specifications and dimensional data on request

For additional information, refer to *Design of bearing arrangements* (→ **page 1046**).

Components

SKF can supply the components of cylindrical roller thrust bearings (→ **fig. 3**) separately. The components are listed in the product tables and include:

- cylindrical roller and cage thrust assemblies (prefix K)
- shaft washers (prefix WS)
- housing washers (prefix GS)

Single components might be required for applications where:

- The faces of adjacent machine components can serve as raceways and bearing arrangements with a low axial section height are required.
- Other combinations of cylindrical roller and cage thrust assemblies and washers are required, for example with two shaft or housing washers.

Bearing washers

SKF supplies bearing washers in different designs and series. Bearing washers are required in cases where adjacent machine components cannot serve as raceways. Appropriate washers are listed in the product tables.

Shaft and housing washers

Shaft washers (prefix WS) and housing washers (prefix GS) are made of hardened carbon chromium bearing steel. The raceway surfaces are precision ground. Shaft washers have a ground bore while housing washers have a ground outside surface. Therefore, SKF rec-

Fig. 3

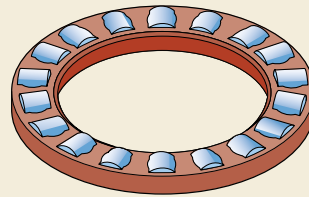

Prefix K

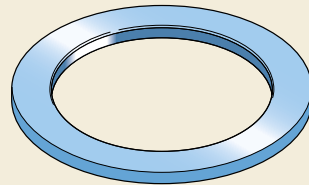

Prefix WS

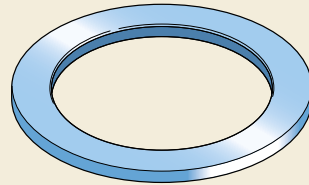

Prefix GS

ommends using these washers in high-speed applications where accurate centring of the bearing washers is required.

LS series universal washers

LS series universal washers can be used as both shaft or housing washers for bearings in the 811 series. These washers are used for applications where accurate centring of the bearing washers is not necessary or where slow speeds are involved.

For additional information about these washers, refer to *Needle roller thrust bearings* (→ **page 1057**).

11 Cylindrical roller thrust bearings



Cages

Depending on their series and size, SKF cylindrical roller thrust bearings are fitted with one of the cages shown in **table 1**.

The lubricants generally used for rolling bearings do not have a detrimental effect on cage properties. However, some synthetic oils and greases with a synthetic oil base and lubricants containing a high proportion of EP additives, when used at high temperatures, can have a detrimental effect on polyamide cages. For additional information about the suitability of cages, refer to *Cages* (→ **page 37**) and *Cage materials* (→ **page 152**).

Table 1

Cages for cylindrical roller thrust bearings

		
Material	Glass fibre reinforced PA66	Machined brass
Suffix	TN	M

Bearing data

Dimension standards	Boundary dimensions: ISO 104
Tolerances	Normal Check availability of P5 for larger bearings Values: ISO 199 (→ table 10, page 144)
For additional information (→ page 132)	Components: (→ table 2, page 1042) Values: (→ table 3, page 1043) Variation of gauge lot diameter of the rollers: ISO 12297
Misalignment	Cannot tolerate any angular misalignment between the shaft and the housing or between the shaft and the axial support surfaces in the housing.
Friction, starting torque, power loss	Frictional moment, starting torque and power loss can be calculated as specified under <i>Friction</i> (→ page 97), or using the tools available online at skf.com/bearingcalculator .
Defect frequencies	Defect frequencies can be calculated using the tools available online at skf.com/bearingcalculator .

11 Cylindrical roller thrust bearings

Table 2

Tolerances for cylindrical roller thrust bearings

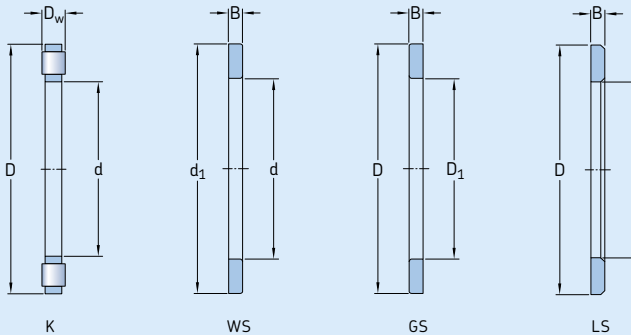

Bearing component Dimensions	Tolerance, tolerance class ¹⁾ , standard
---------------------------------	---

Cylindrical roller and cage thrust assemblies, K

Bore diameter	d	E11
Outside diameter	D	a13
Roller diameter	D_w	ISO 12297

Shaft washers, WS

Bore diameter	d	Normal, ISO 199
Outside diameter	d_1	–
Thickness	B	h11
Axial run-out	s_i	Normal, ISO 199

Housing washers, GS

Outside diameter	D	Normal, ISO 199
Bore diameter	D_1	–
Thickness	B	h11
Axial run-out	s_e	Normal, ISO 199

Universal washers, LS

Bore diameter	d	E12
Outside diameter	D	a12
Thickness	B	h11
Axial run-out	s_i	Normal, ISO 199

¹⁾ All ISO tolerance classes are valid with the envelope requirement (such as H7(ES)) in accordance with ISO 14405-1.

Table 3

ISO tolerance classes

Nominal dimension		a12(E) Deviations		a13(E) Deviations		E11(E) Deviations		E12(E) Deviations		h11(E) Deviations	
over	incl.	high	low	high	low	high	low	high	low	high	low
mm		µm		µm		µm		µm		µm	
-	3	-	-	-	-	-	-	-	-	0	-60
3	6	-	-	-	-	-	-	-	-	0	-75
6	10	-	-	-	-	-	-	-	-	0	-90
10	18	-	-	-	-	+142	+32	+212	+32	0	-110
18	30	-300	-510	-300	-630	+170	+40	+250	+40	0	-130
30	40	-310	-560	-310	-700	+210	+50	+300	+50	-	-
40	50	-320	-570	-320	-710	+210	+50	+300	+50	-	-
50	65	-340	-640	-340	-800	+250	+60	+360	+60	-	-
65	80	-360	-660	-360	-820	+250	+60	+360	+60	-	-
80	100	-380	-730	-380	-920	+292	+72	+422	+72	-	-
100	120	-410	-760	-410	-950	+292	+72	+422	+72	-	-
120	140	-460	-860	-460	-1 090	+335	+85	+485	+85	-	-
140	160	-520	-920	-520	-1 150	+335	+85	+485	+85	-	-
160	180	-580	-980	-580	-1 210	+335	+85	-	-	-	-
180	200	-660	-1 120	-660	-1 380	+390	+100	-	-	-	-
200	225	-	-	-740	-1 460	+390	+100	-	-	-	-
225	250	-	-	-820	-1 540	+390	+100	-	-	-	-
250	280	-	-	-920	-1 730	+430	+110	-	-	-	-
280	315	-	-	-1 050	-1 860	+430	+110	-	-	-	-
315	355	-	-	-1 200	-2 090	+485	+125	-	-	-	-
355	400	-	-	-1 350	-2 240	+485	+125	-	-	-	-
400	450	-	-	-1 500	-2 470	+535	+135	-	-	-	-
450	500	-	-	-1 650	-2 620	+535	+135	-	-	-	-
500	630	-	-	-1 900	-3 000	+585	+145	-	-	-	-
630	800	-	-	-2 100	-3 350	-	-	-	-	-	-

11 Cylindrical roller thrust bearings

Loads

	Cylindrical roller thrust bearings	Symbols
Minimum load For additional information (→ page 86)	$F_{am} = 0,0005 C_0 + A \left(\frac{n}{1\,000} \right)^2$ <p>The weight of the components supported by the bearing, particularly when the shaft is vertical, together with external forces, generally exceed the requisite minimum load. If this is not the case, the bearing must be subjected to an additional axial load by using springs or a shaft nut.</p>	A = minimum load factor (→ product tables) C ₀ = basic static load rating [kN] (→ product tables) F _a = axial load [kN] F _{am} = minimum axial load [kN] n = rotational speed [r/min] P = equivalent dynamic bearing load [kN] P ₀ = equivalent static bearing load [kN]
Equivalent dynamic bearing load For additional information (→ page 85)	$P = F_a$	
Equivalent static bearing load For additional information (→ page 88)	$P_0 = F_a$	

Temperature limits

The permissible operating temperature for cylindrical roller thrust bearings can be limited by:

- the dimensional stability of the bearing washers and rollers
- the cage
- the lubricant

When temperatures outside the permissible range are expected, contact the SKF application engineering service.

Bearing washers and rollers

SKF cylindrical roller thrust bearings undergo a special heat treatment. The bearings are heat stabilized up to at least 120 °C (250 °F).

Cages

Brass cages can be used at the same operating temperatures as the bearing washers and rollers. For temperature limits of polymer cages, refer to *Cage materials* (→ **page 152**).

Lubricants

Temperature limits for SKF greases are provided under *Lubrication* (→ **page 239**). When using lubricants not supplied by SKF, the temperature limits should be evaluated according to the SKF traffic light concept (→ **page 244**).

Permissible speed

The permissible speed can be estimated using the speed ratings listed in the product tables and applying the information provided under *Speeds* (→ **page 117**).

11 Cylindrical roller thrust bearings

Design of bearing arrangements

Abutment dimensions

The support surfaces in housings and on shafts should be at right angles to the shaft axis and provide uninterrupted support over the entire washer face. The abutment diameter on the shaft should be $\geq d_{a\min}$ and in the housing $\leq D_{a\max}$ (→ **fig. 4**). Values for $d_{a\min}$ and $D_{a\max}$ are listed in the product tables.

To provide satisfactory radial guidance for the individual thrust bearing components, suitable tolerance classes for shafts and housings are listed in **table 4**. A radial gap between the shaft and washer bore is required for housing centred washers. Shaft centred washers require a radial gap between the washer and housing bore.

Cylindrical roller and cage thrust assemblies are generally centred radially by the shaft, to reduce the circumferential speed at which the cage slides against the guiding surface. This is particularly important for higher speed applications. The guiding surface should be ground.

Raceways on shafts and in housings

If the load carrying capacity of a cylindrical roller and cage thrust assembly is to be fully exploited, the raceways on the shaft or in the housing should have the same hardness, surface finish and axial run-out as a bearing washer.

The dimensions E_a and E_b (→ **product tables**) take the possible displacement of the roller set into consideration and should be applied when designing raceways on shafts and in housings.

For additional information, refer to *Raceways on shafts and in housings* (→ **page 210**).

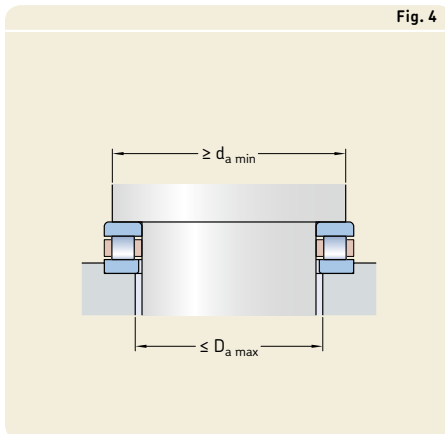

Fig. 4

Table 4

Shaft and housing tolerance classes

Bearing component	Prefix	Tolerance class ¹⁾	
		Shaft centred	Housing centred
Cylindrical roller and cage thrust assemblies	K	h8	–
Shaft washers	WS	h8	–
Housing washers	GS	–	H9

¹⁾ All ISO tolerance classes are valid with the envelope requirement (such as H7 \oplus) in accordance with ISO 14405-1.

Designation system

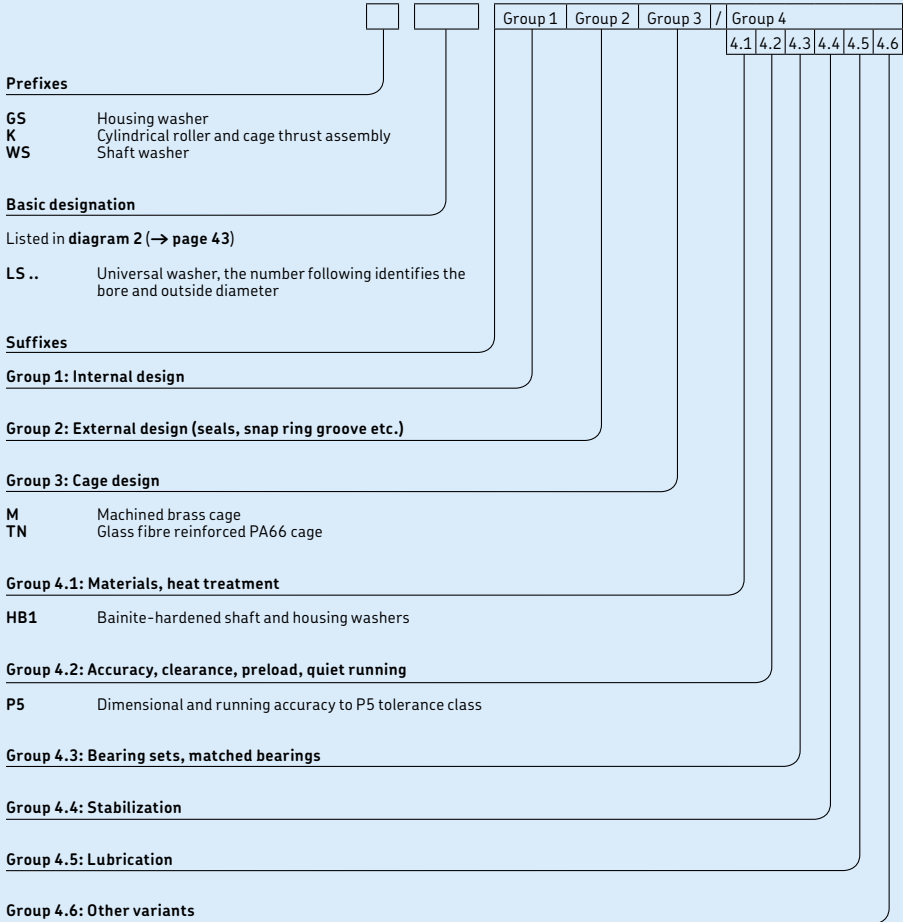

11.1 Cylindrical roller thrust bearings

d 15 – 65 mm

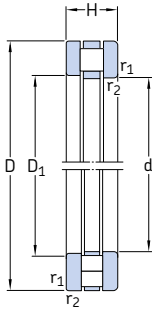

811, 812
893, 894

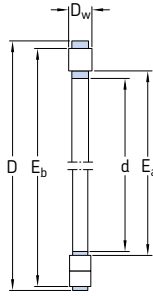

K 811, K 812
K 893, K 894

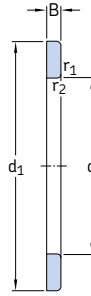

WS

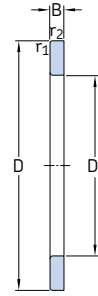

GS

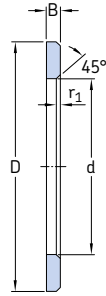

LS

Principal dimensions				Basic load ratings		Fatigue load limit	Minimum load factor	Speed ratings	Mass	Designation		
d	D	H	E _a	E _b	dynamic C	static C ₀	P _u	Reference speed	Limiting speed			
mm					kN		kN	r/min	kg	-		
15	28	9	16	27	11,2	27	2,45	0,000 058	4 300	8 500	0,024	81102 TN
17	30	9	18	29	12,2	31,5	2,85	0,000 079	4 300	8 500	0,027	81103 TN
20	35	10	21	34	18,6	48	4,65	0,00018	3 800	7 500	0,037	81104 TN
25	42	11	26	41	25	69,5	6,8	0,00039	3 200	6 300	0,053	81105 TN
30	47	11	31	46	27	78	7,65	0,00049	3 000	6 000	0,057	81106 TN
52	16	31	50	50	134	13,4	0,0014	2 400	4 800	0,12	81206 TN	
60	18	33	59	52	183	18,3	0,0027	2 600	5 300	0,24	89306 TN	
35	52	12	36	51	29	93	9,15	0,00069	2 800	5 600	0,073	81107 TN
62	18	39	58	62	190	19,3	0,0029	2 000	4 000	0,21	81207 TN	
68	20	38	67	62	220	22	0,0039	2 400	4 800	0,34	89307 TN	
40	60	13	42	58	43	137	13,7	0,0015	2 400	5 000	0,11	81108 TN
68	19	43	66	83	255	26,5	0,0052	1 900	3 800	0,25	81208 TN	
78	22	44	77	95	365	36,5	0,011	2 000	4 000	0,48	89308 TN	
45	65	14	47	63	45	153	15,3	0,0019	2 200	4 500	0,13	81109 TN
73	20	48	70	83	255	26,5	0,0052	1 800	3 600	0,29	81209 TN	
85	24	49	83	108	425	43	0,014	1 800	3 600	0,62	89309 TN	
50	70	14	52	68	47,5	166	16,6	0,0022	2 200	4 300	0,14	81110 TN
78	22	53	75	91,5	300	31	0,0072	1 700	3 400	0,36	81210 TN	
95	27	56	92	132	530	54	0,022	1 600	3 200	0,89	89310 TN	
55	78	16	57	77	69,5	285	29	0,0065	1 900	3 800	0,23	81111 TN
90	25	59	85	122	390	40	0,012	1 400	2 800	0,57	81211 TN	
105	30	61	103	143	570	58,5	0,026	1 500	3 000	1,2	89311 TN	
60	85	17	62	82	80	300	30,5	0,0072	1 800	3 600	0,27	81112 TN
95	26	64	91	137	465	47,5	0,017	1 400	2 800	0,65	81212 TN	
110	30	66	108	153	640	65,5	0,033	1 400	2 800	1,25	89312 TN	
130	42	65	126	310	1 180	125	0,11	1 200	2 400	2,8	89412 TN	
65	90	18	67	87	83	320	32,5	0,0082	1 700	3 400	0,31	81113 TN
100	27	69	96	140	490	50	0,019	1 300	2 600	0,72	81213 TN	
115	30	71	113	153	640	65,5	0,033	1 400	2 800	1,35	89313 TN	
140	45	70	135	355	1 370	143	0,15	1 100	2 200	3,5	89413 TN	

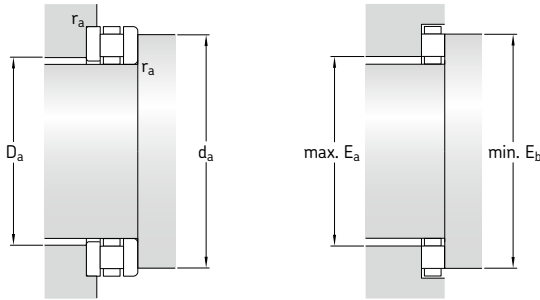

Dimensions						Abutment and fillet dimensions			Designation of components		Housing washer	Universal washer
d	d ₁	D ₁	B	D _w	r _{1,2}	d _a	D _a	r _a	Cylindrical roller and cage thrust assembly	Shaft washer		
						mm			-			
						mm						
15	28	16	2,75	3,5	0,3	27	16	0,3	K 81102 TN	WS 81102	GS 81102	LS 1528
17	30	18	2,75	3,5	0,3	29	18	0,3	K 81103 TN	WS 81103	GS 81103	LS 1730
20	35	21	2,75	4,5	0,3	34	21	0,3	K 81104 TN	WS 81104	GS 81104	LS 2035
25	42	26	3	5	0,6	41	26	0,6	K 81105 TN	WS 81105	GS 81105	LS 2542
30	47	32	3	5	0,6	46	31	0,6	K 81106 TN	WS 81106	GS 81106	LS 3047
	52	32	4,25	7,5	0,6	50	31	0,6	K 81206 TN	WS 81206	GS 81206	-
	60	32	6,25	5,5	1	59	33	1	K 89306 TN	WS 89306	GS 89306	-
35	52	37	3,5	5	0,6	51	36	0,6	K 81107 TN	WS 81107	GS 81107	LS 3552
	62	37	5,25	7,5	1	58	39	1	K 81207 TN	WS 81207	GS 81207	-
	68	37	7	6	1	67	38	1	K 89307 TN	WS 89307	GS 89307	-
40	60	42	3,5	6	0,6	58	42	0,6	K 81108 TN	WS 81108	GS 81108	LS 4060
	68	42	5	9	1	66	43	1	K 81208 TN	WS 81208	GS 81208	-
	78	42	7,5	7	1	77	44	1	K 89308 TN	WS 89308	GS 89308	-
45	65	47	4	6	0,6	63	47	0,6	K 81109 TN	WS 81109	GS 81109	LS 4565
	73	47	5,5	9	1	70	48	1	K 81209 TN	WS 81209	GS 81209	-
	85	47	8,25	7,5	1	83	49	1	K 89309 TN	WS 89309	GS 89309	-
50	70	52	4	6	0,6	68	52	0,6	K 81110 TN	WS 81110	GS 81110	LS 5070
	78	52	6,5	9	1	75	53	1	K 81210 TN	WS 81210	GS 81210	-
	95	52	9,5	8	1,1	92	56	1,1	K 89310 TN	WS 89310	GS 89310	-
55	78	57	5	6	0,6	77	56	0,6	K 81111 TN	WS 81111	GS 81111	LS 5578
	90	57	7	11	1	85	59	1	K 81211 TN	WS 81211	GS 81211	-
	105	57	10,5	9	1,1	103	62	1,1	K 89311 TN	WS 89311	GS 89311	-
60	85	62	4,75	7,5	1	82	62	1	K 81112 TN	WS 81112	GS 81112	LS 6085
	95	62	7,5	11	1	91	64	1	K 81212 TN	WS 81212	GS 81212	-
	110	62	10,5	9	1,1	108	67	1,1	K 89312 TN	WS 89312	GS 89312	-
	130	62	14	14	1,5	126	65	1,5	K 89412 TN	WS 89412	GS 89412	-
65	90	67	5,25	7,5	1	87	67	1	K 81113 TN	WS 81113	GS 81113	LS 6590
	100	67	8	11	1	96	69	1	K 81213 TN	WS 81213	GS 81213	-
	115	67	10,5	9	1,1	113	72	1,1	K 89313 TN	WS 89313	GS 89313	-
	140	68	15	15	2	135	70	2	K 89413 TN	WS 89413	GS 89413	-

11.1 Cylindrical roller thrust bearings d 70 – 120 mm

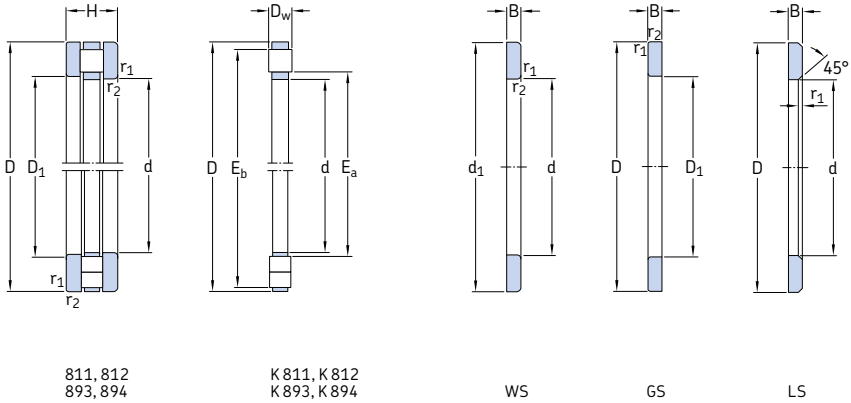

Principal dimensions				Basic load ratings		Fatigue load limit	Minimum load factor	Speed ratings		Mass	Designation	
d	D	H	E _a	E _b	dynamic C	static C ₀	P _u	A	Reference speed	Limiting speed	kg	-
mm					kN		kN	-	r/min		kg	-
70	95	18	72	92	86,5	345	34,5	0,0095	1 700	3 400	0,33	81114 TN
	105	27	74	102	146	530	55	0,022	1 300	2 600	0,77	81214 TN
	125	34	76	123	186	800	81,5	0,051	1 300	2 600	1,8	89314 TN
	150	48	76	147	380	1 460	150	0,17	1 000	2 000	4,2	89414 TN
75	100	19	78	97	83	335	34	0,009	1 600	3 200	0,39	81115 TN
	110	27	79	106	137	490	50	0,019	1 200	2 400	0,8	81215 TN
	135	36	81	132	228	965	98	0,074	1 200	2 400	2,25	89315 TN
	160	51	82	156	400	1 530	156	0,19	950	1 900	5,95	89415 M
80	105	19	83	102	81,5	335	34	0,009	1 500	3 000	0,4	81116 TN
	115	28	84	112	160	610	63	0,03	1 200	2 400	0,9	81216 TN
	140	36	86	137	240	1 060	108	0,09	1 200	2 400	2,35	89316 TN
	170	54	88	165	440	1 730	173	0,24	900	1 800	7,05	89416 M
85	110	19	87	108	88	365	37,5	0,011	1 500	3 000	0,42	81117 TN
	125	31	90	119	170	640	67	0,033	1 100	2 200	1,2	81217 TN
	150	39	93	146	255	1 100	110	0,097	1 100	2 200	3,4	89317 M
	180	58	93	175	490	1 930	190	0,3	850	1 700	8,65	89417 M
90	120	22	93	117	110	450	45,5	0,016	1 300	2 600	0,62	81118 TN
	135	35	95	129	232	865	90	0,06	1 000	2 000	1,75	81218 TN
	155	39	98	151	265	1 160	114	0,11	1 000	2 000	3,65	89318 M
	190	60	99	185	540	2 120	208	0,36	800	1 600	9,95	89418 M
100	135	25	104	131	156	630	62	0,032	1 200	2 400	0,95	81120 TN
	150	38	107	142	270	1 060	104	0,09	900	1 800	2,2	81220 TN
	170	42	109	166	300	1 370	132	0,15	950	1 900	4,55	89320 M
	210	67	111	205	680	2 800	265	0,63	700	1 400	13,5	89420 M
110	145	25	114	141	163	680	65,5	0,037	1 100	2 200	1,05	81122 TN
	160	38	117	152	260	1 000	98	0,08	850	1 700	2,3	81222 TN
	190	48	120	185	400	1 830	173	0,27	850	1 700	6,7	89322 M
	230	73	121	223	800	3 350	310	0,9	630	1 300	17,5	89422 M
120	155	25	124	151	170	735	68	0,043	1 100	2 200	1,1	81124 TN
	170	39	127	162	255	1 000	96,5	0,08	800	1 600	2,55	81224 TN
	210	54	132	205	510	2 360	216	0,45	750	1 500	9,45	89324 M
	250	78	133	243	930	3 900	355	1,2	600	1 200	22	89424 M

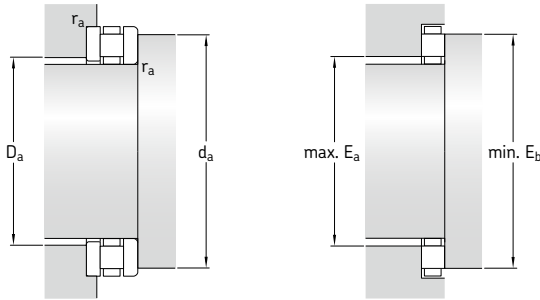

Dimensions						Abutment and fillet dimensions			Designation of components		Housing washer	Universal washer
d	d ₁	D ₁	B	D _w	r _{1,2} min.	d _a min.	D _a max.	r _a max.	Cylindrical roller and cage thrust assembly	Shaft washer		
mm						mm			-			
70	95	72	5,25	7,5	1	92	72	1	K 81114 TN	WS 81114	GS 81114	LS 7095
	105	72	8	11	1	102	74	1	K 81214 TN	WS 81214	GS 81214	-
	125	72	12	10	1,1	123	78	1,1	K 89314 TN	WS 89314	GS 89314	-
	150	73	16	16	2	147	78	2	K 89414 TN	WS 89414	GS 89414	-
75	100	77	5,75	7,5	1	97	78	1	K 81115 TN	WS 81115	GS 81115	LS 75100
	110	77	8	11	1	106	79	1	K 81215 TN	WS 81215	GS 81215	-
	135	77	12,5	11	1,5	132	83	1,5	K 89315 TN	WS 89315	GS 89315	-
	160	78	17	17	2	156	84	2	K 89415 M	WS 89415	GS 89415	-
80	105	82	5,75	7,5	1	102	83	1	K 81116 TN	WS 81116	GS 81116	LS 80105
	115	82	8,5	11	1	112	84	1	K 81216 TN	WS 81216	GS 81216	-
	140	82	12,5	11	1,5	137	88	1,5	K 89316 TN	WS 89316	GS 89316	-
	170	83	18	18	2,1	166	89	2,1	K 89416 M	WS 89416	GS 89416	-
85	110	87	5,75	7,5	1	108	87	1	K 81117 TN	WS 81117	GS 81117	LS 85110
	125	88	9,5	12	1	119	90	1	K 81217 TN	WS 81217	GS 81217	-
	150	88	13,5	12	1,5	147	93	1,5	K 89317 M	WS 89317	GS 89317	-
	180	88	19,5	19	2,1	176	94	2,1	K 89417 M	WS 89417	GS 89417	-
90	120	92	6,5	9	1	117	93	1	K 81118 TN	WS 81118	GS 81118	LS 90120
	135	93	10,5	14	1,1	129	95	1,1	K 81218 TN	WS 81218	GS 81218	-
	155	93	13,5	12	1,5	152	98	1,5	K 89318 M	WS 89318	GS 89318	-
	190	93	20	20	2,1	186	100	2,1	K 89418 M	WS 89418	GS 89418	-
100	135	102	7	11	1	131	104	1	K 81120 TN	WS 81120	GS 81120	LS 100135
	150	103	11,5	15	1,1	142	107	1,1	K 81220 TN	WS 81220	GS 81220	-
	170	103	14,5	13	1,5	167	109	1,5	K 89320 M	WS 89320	GS 89320	-
	210	103	22,5	22	3	206	112	3	K 89420 M	WS 89420	GS 89420	-
110	145	112	7	11	1	141	114	1	K 81122 TN	WS 81122	GS 81122	LS 110145
	160	113	11,5	15	1,1	152	117	1,1	K 81222 TN	WS 81222	GS 81222	-
	190	113	16,5	15	2	186	120	2	K 89322 M	WS 89322	GS 89322	-
	230	113	24,5	24	3	225	123	3	K 89422 M	WS 89422	GS 89422	-
120	155	122	7	11	1	151	124	1	K 81124 TN	WS 81124	GS 81124	LS 120155
	170	123	12	15	1,1	162	127	1,1	K 81224 TN	WS 81224	GS 81224	-
	210	123	18,5	17	2,1	206	130	2,1	K 89324 M	WS 89324	GS 89324	-
	250	123	26	26	4	245	135	4	K 89424 M	WS 89424	GS 89424	-

11.1 Cylindrical roller thrust bearings

d 130 – 240 mm

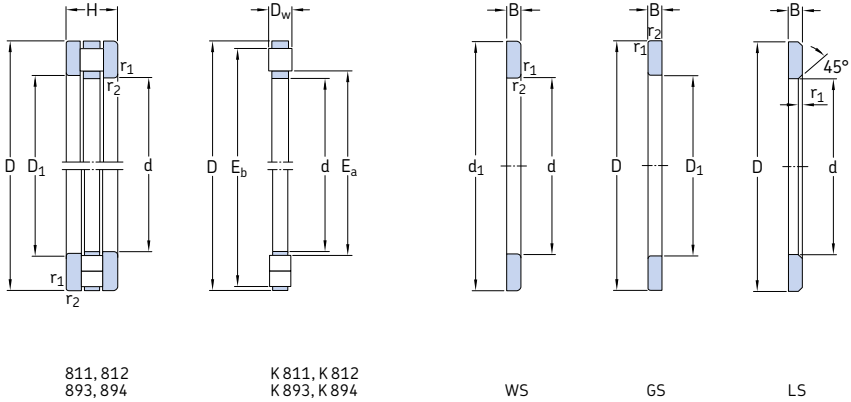

Principal dimensions				Basic load ratings		Fatigue load limit P_u	Minimum load factor A	Speed ratings		Mass kg	Designation	
d	D	H	E_a	E_b	dynamic C			static C_0	Reference speed			Limiting speed
mm						kN	kN	r/min		-		
130	170	30	135	165	200	880	81,5	0,062	950	1 900	1,65	81126 TN
	190	45	137	181	380	1 460	137	0,17	700	1 400	4	81226 TN
	225	58	141	219	560	2 650	240	0,56	700	1 400	11	89326 M
	270	85	145	263	1 060	4 500	400	1,6	530	1 100	27	89426 M
140	180	31	145	175	208	930	85	0,069	900	1 800	1,9	81128 TN
	200	46	150	191	360	1 400	129	0,16	700	1 400	5,05	81228 M
	240	60	152	234	640	3 100	275	0,77	670	1 300	12,5	89328 M
	280	85	155	273	1 100	4 800	425	1,8	530	1 100	29,5	89428 M
150	190	31	155	185	212	1 000	88	0,08	850	1 700	2,2	81130 TN
	215	50	162	210	465	1 900	170	0,29	630	1 300	7,2	81230 M
	250	60	162	244	670	3 250	285	0,85	630	1 300	14	89330 M
	300	90	167	293	1 250	5 600	480	2,5	500	1 000	35,5	89430 M
160	200	31	165	195	216	1 020	90	0,08	850	1 700	2,1	81132 TN
	225	51	171	219	480	2 000	176	0,32	600	1 200	7,6	81232 M
	320	95	179	313	1 430	6 400	540	3,3	480	950	42	89432 M
170	215	34	176	209	285	1 340	118	0,14	800	1 600	2,4	81134 TN
	240	55	184	233	540	2 280	200	0,42	560	1 100	9,3	81234 M
	340	103	191	333	1 600	7 200	600	4,1	430	850	52	89434 M
180	225	34	185	219	270	1 270	110	0,13	750	1 500	3,7	81136 M
	250	56	194	243	550	2 400	204	0,46	560	1 100	9,95	81236 M
	360	109	200	351	1 760	8 000	655	5,1	400	800	60	89436 M
190	240	37	197	233	310	1 460	125	0,17	700	1 400	4,75	81138 M
	270	62	205	263	695	2 900	250	0,67	500	1 000	12	81238 M
	380	115	212	371	1 960	9 000	720	6,5	380	750	65,5	89438 M
200	250	37	206	243	310	1 500	125	0,18	700	1 400	4,95	81140 M
	280	62	215	273	720	3 100	255	0,77	500	1 000	13,5	81240 M
	400	122	224	391	2 160	10 000	800	8	360	700	75	89440 M
220	270	37	226	263	335	1 700	137	0,23	670	1 300	5,2	81144 M
	300	63	236	294	750	3 350	275	0,9	480	950	15	81244 M
	420	122	244	411	2 320	11 200	880	10	340	700	84,5	89444 M
240	300	45	248	296	475	2 450	196	0,48	560	1 100	8,45	81148 M
	340	78	263	333	1 100	4 900	390	1,9	400	800	22	81248 M

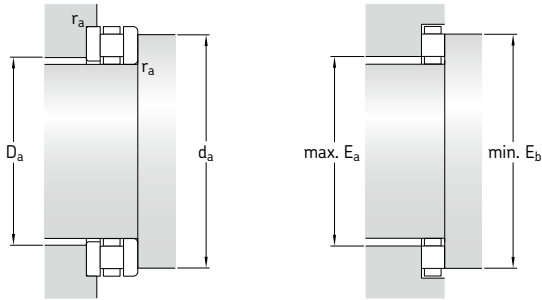

Dimensions					Abutment and fillet dimensions			Designation of components		Housing washer	Universal washer	
d	d ₁	D ₁	B	D _w	r _{1,2} min.	d _a min.	D _a max.	r _a max.	Cylindrical roller and cage thrust assembly			Shaft washer
mm						mm			-			
130	170	132	9	12	1	165	135	1	K 81126 TN	WS 81126	GS 81126	LS 130170
	187	133	13	19	1,5	181	137	1,5	K 81226 TN	WS 81226	GS 81226	-
	225	134	20	18	2,1	220	141	2,1	K 89326 M	WS 89326	GS 89326	-
	270	134	28,5	28	4	265	147	4	K 89426 M	WS 89426	GS 89426	-
140	178	142	9,5	12	1	175	145	1	K 81128 TN	WS 81128	GS 81128	LS 140180
	197	143	13,5	19	1,5	191	147	1,5	K 81228 M	WS 81228	GS 81228	-
	240	144	20,5	19	2,1	235	152	2,1	K 89328 M	WS 89328	GS 89328	-
	280	144	28,5	28	4	275	157	4	K 89428 M	WS 89428	GS 89428	-
150	188	152	9,5	12	1	185	155	1	K 81130 TN	WS 81130	GS 81130	LS 150190
	212	153	14,5	21	1,5	211	158	1,5	K 81230 M	WS 81230	GS 81230	-
	250	154	20,5	19	2,1	245	162	2,1	K 89330 M	WS 89330	GS 89330	-
	300	154	30	30	4	295	168	4	K 89430 M	WS 89430	GS 89430	-
160	198	162	9,5	12	1	195	165	1	K 81132 TN	WS 81132	GS 81132	LS 160200
	220	163	15	21	1,5	220	168	1,5	K 81232 M	WS 81232	GS 81232	-
	320	164	31,5	32	5	315	179	5	K 89432 M	WS 89432	GS 89432	-
170	213	172	10	14	1,1	209	176	1,1	K 81134 TN	WS 81134	GS 81134	-
	237	173	16,5	22	1,5	235	180	1,5	K 81234 M	WS 81234	GS 81234	-
	340	174	34,5	34	5	335	191	5	K 89434 M	WS 89434	GS 89434	-
180	222	183	10	14	1,1	219	185	1,1	K 81136 M	WS 81136	GS 81136	-
	247	183	17	22	1,5	245	190	1,5	K 81236 M	WS 81236	GS 81236	-
	360	184	36,5	36	5	353	203	5	K 89436 M	WS 89436	GS 89436	-
190	237	193	11	15	1,1	233	197	1,1	K 81138 M	WS 81138	GS 81138	-
	267	194	18	26	2	265	200	2	K 81238 M	WS 81238	GS 81238	-
	380	195	38,5	38	5	373	214	5	K 89438 M	WS 89438	GS 89438	-
200	250	203	11	15	1,1	243	206	1,1	K 81140 M	WS 81140	GS 81140	-
	277	204	18	26	2	275	210	2	K 81240 M	WS 81240	GS 81240	-
	400	205	41	40	5	393	226	5	K 89440 M	WS 89440	GS 89440	-
220	267	223	11	15	1,1	263	226	1,1	K 81144 M	WS 81144	GS 81144	-
	297	224	18,5	26	2	296	230	2	K 81244 M	WS 81244	GS 81244	-
	420	225	41	40	6	413	246	6	K 89444 M	WS 89444	GS 89444	-
240	297	243	13,5	18	1,5	296	248	1,5	K 81148 M	WS 81148	GS 81148	-
	335	244	23	32	2,1	335	261	2,1	K 81248 M	WS 81248	GS 81248	-

11.1

11.1 Cylindrical roller thrust bearings d 260 – 630 mm

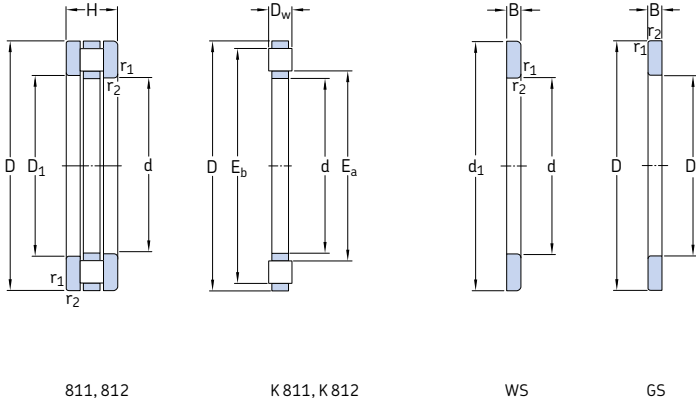

Principal dimensions				Basic load ratings		Fatigue load limit P_u	Minimum load factor A	Speed ratings		Mass kg	Designation	
d	D	H	E_a	E_b	dynamic C			static C_0	Reference speed			Limiting speed
mm					kN		kN	–	r/min		–	
260	320	45	268	316	490	2 600	200	0,54	530	1 100	9,1	81152 M
	360	79	281	351	1 140	5 300	415	2,20	380	750	27	81252 M
280	350	53	288	346	680	3 550	275	1	480	950	12,5	81156 M
	380	80	301	371	1 160	5 500	425	2,4	360	750	30	81256 M
300	380	62	315	373	850	4 400	335	1,5	430	850	19,5	81160 M
	420	95	329	412	1 530	7 200	540	4	320	630	43	81260 M
320	400	63	334	394	880	4 650	345	1,7	400	800	20,5	81164 M
	440	95	348	434	1 560	7 500	550	4,5	300	600	42,5	81264 M
340	420	64	354	414	900	4 900	355	1,9	380	800	22,5	81168 M
	460	96	367	452	1 630	8 000	585	5,1	300	600	47	81268 M
360	440	65	374	434	900	4 900	355	1,9	380	750	19,5	81172 M
	500	110	393	492	2 160	10 400	750	8,7	260	530	65,5	81272 M
380	460	65	393	453	930	5 300	375	2,2	360	750	22	81176 M
400	480	65	413	473	965	5 600	390	2,5	360	700	23	81180 M
420	500	65	433	493	980	5 850	400	2,7	340	700	24	81184 M
440	540	80	459	533	1 430	8 000	550	5,1	300	600	39,5	81188 M
460	560	80	479	553	1 460	8 500	570	5,8	300	600	41	81192 M
480	580	80	500	573	1 460	8 650	585	6,0	280	560	43	81196 M
500	600	80	519	592	1 560	9 300	620	6,9	280	560	44	811/500 M
530	640	85	554	632	1 730	10 600	680	9	260	530	55,5	811/530 M
560	670	85	584	662	1 760	11 100	710	9,7	260	500	58	811/560 M
600	710	85	624	702	1 800	11 600	720	11	240	500	62	811/600 M
630	750	95	650	732	2 160	13 700	865	15,0	220	450	80	811/630 M

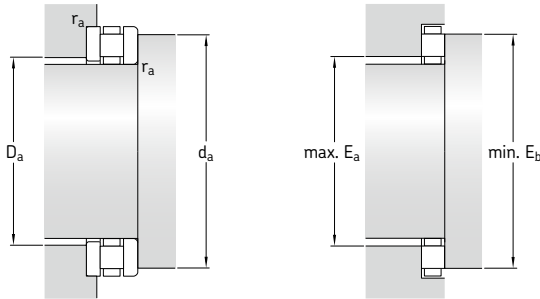

Dimensions					Abutment and fillet dimensions			Designation of components			
d	d ₁ ~	D ₁ ~	B	D _w	r _{1,2} min.	d _a min.	D _a max.	r _a max.	Cylindrical roller and cage thrust assembly	Shaft washer	Housing washer
mm						mm			-		
260	317	263	13,5	18	1,5	316	268	1,5	K 81152 M	WS 81152	GS 81152
	355	264	23,5	32	2,1	353	280	2,1			
280	347	283	15,5	22	1,5	346	288	1,5	K 81156 M	WS 81156	GS 81156
	375	284	24	32	2,1	373	300	2,1			
300	376	304	18,5	25	2	373	315	2	K 81160 M	WS 81160	GS 81160
	415	304	28,5	38	3	413	328	3			
320	396	324	19	25	2	394	334	2	K 81164 M	WS 81164	GS 81164
	435	325	28,5	38	3	434	348	2,5			
340	416	344	19,5	25	2	414	354	2	K 81168 M	WS 81168	GS 81168
	455	345	29	38	3	452	367	2,5			
360	436	364	20	25	2	434	374	2	-	-	-
	495	365	32,5	45	4	492	393	3			
380	456	384	20	25	2	453	393	2	-	-	-
400	476	404	20	25	2	473	413	2	-	-	-
420	495	424	20	25	2	493	433	2	-	-	-
440	535	444	24	32	2,1	533	459	2	-	-	-
460	555	464	24	32	2,1	553	479	2	-	-	-
480	575	484	24	32	2,1	573	500	2	-	-	-
500	595	505	24	32	2,1	592	519	2	-	-	-
530	635	535	25,5	34	3	632	554	2,5	-	-	-
560	665	565	25,5	34	3	662	584	2,5	-	-	-
600	705	605	25,5	34	3	702	624	2,5	-	-	-
630	746	634	28,5	38	3	732	650	2,5	-	-	-

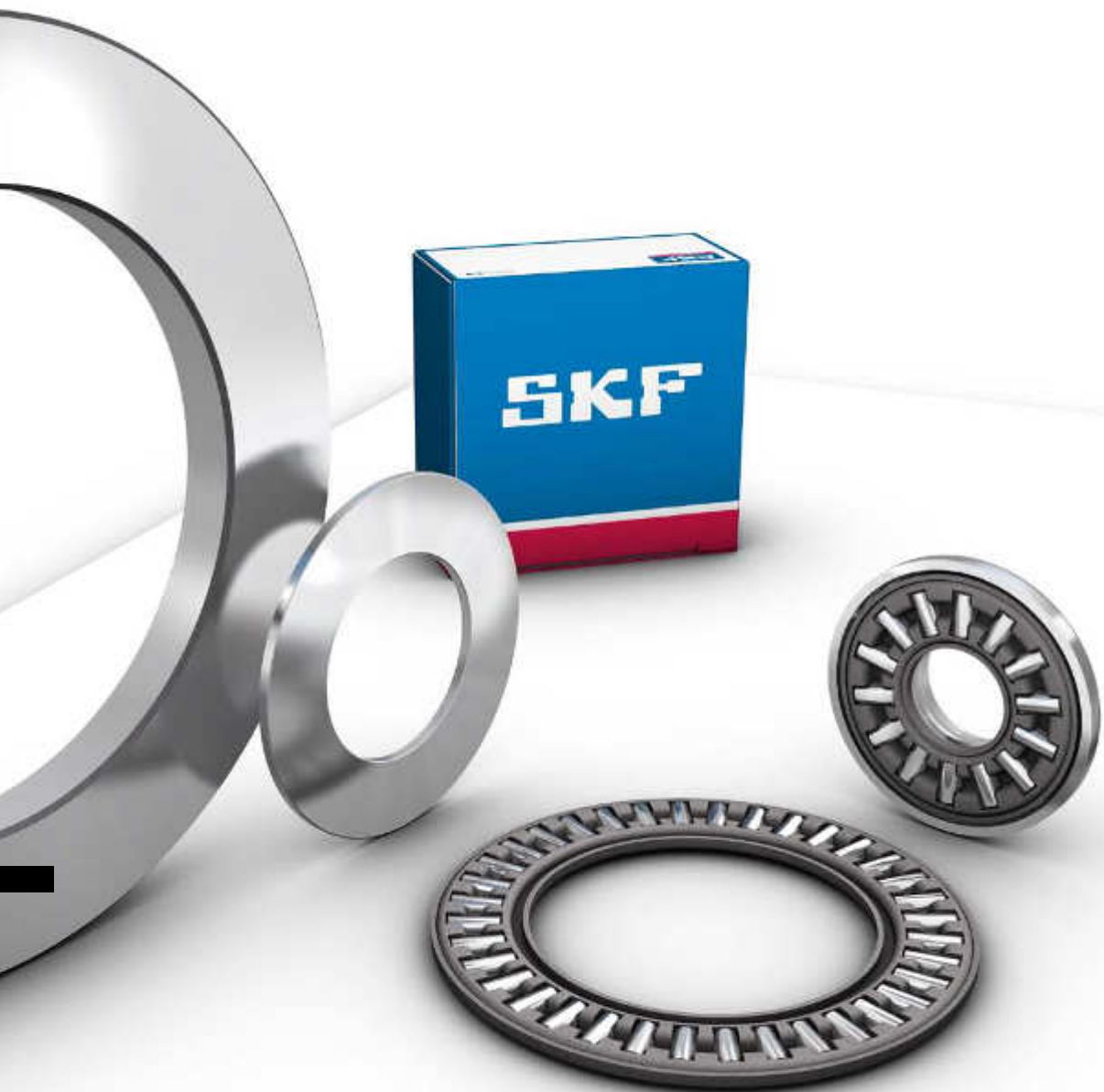

12 Needle roller thrust bearings

Designs and variants 1058

Needle roller and cage thrust assemblies	1058
Double direction bearings	1058
Needle roller thrust bearings with a centring flange.	1059
Combined needle roller bearing arrangements.	1060
Bearing washers.	1060
LS series universal washers	1061
AS series thin universal washers.	1061
811 series shaft and housing washers.	1061
Cages.	1062

Bearing data 1063

(Dimension standards, tolerances, misalignment, friction, starting torque, power loss, defect frequencies)

Loads 1066

(Minimum load, equivalent loads)

Temperature limits. 1067

Permissible speed. 1067

Design of bearing arrangements 1068

Abutment dimensions	1068
Raceways on shafts and in housings	1068

Designation system 1069

Product tables

12.1 Needle roller and cage thrust assemblies and appropriate washers.	1070
12.2 Needle roller thrust bearings with a centring flange and appropriate washers.	1074



Designs and variants

SKF needle roller thrust bearings are fitted with a form-stable cage to reliably retain and guide a large number of needle rollers. The very small diameter deviation of the rollers within one assembly enables these bearings to accommodate heavy axial loads and shock loads. The ends of the rollers are relieved slightly to modify the line contact between the raceways and rollers. This prevents stress peaks at the roller ends to extend bearing service life.

Needle roller thrust bearings provide a high degree of stiffness within a minimum axial space. In applications where the faces of adjacent machine components can serve as raceways, needle roller thrust bearings take up no more space than a conventional thrust washer. SKF supplies needle roller thrust bearings in two designs (→ fig. 1):

- needle roller and cage thrust assemblies, AXK series
- needle roller thrust bearings with a centring flange, AXW series (→ fig. 3)

In applications where adjacent components cannot serve as raceways, the assemblies can be combined with bearing washers in different series (→ *Bearing washers*, page 1060).

More information

Bearing life and load ratings	63
Design considerations	159
Abutment and fillet dimensions	208
Lubrication	239
Mounting, dismantling and bearing care	271

Needle roller and cage thrust assemblies

SKF needle roller and cage thrust assemblies in the AXK series (→ fig. 1) are available for shaft diameters ranging from 4 to 160 mm. They can be combined with washers in the LS, AS, GS 811 or WS 811 series (→ *Bearing washers*, page 1060) in applications where adjacent components cannot serve as raceways. These thrust assemblies can accommodate axial loads in one direction only.

Double direction bearings

Double direction needle roller thrust bearings can accommodate axial loads in both directions. They can be created by combining two needle roller and cage thrust assemblies and two bearing washers with an intermediate washer. Depending on the design, an intermediate washer can be shaft or housing centred (→ fig. 2).

Fig. 1

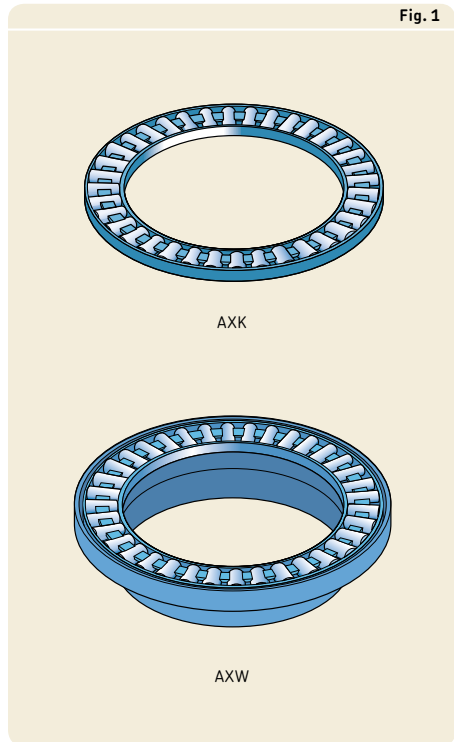

Intermediate washers must have the same hardness and surface finish as bearing washers. SKF does not supply intermediate washers, but provides material specifications and dimensional data on request.

For additional information, refer to *Design of bearing arrangements* (→ **page 1068**).

Needle roller thrust bearings with a centring flange

SKF needle roller thrust bearings in the AXW series (→ **fig. 3**) consist of a needle roller and cage thrust assembly and a thrust washer with a centring flange. The flange facilitates mounting and accurately centres the housing washer radially (→ **figs. 4 and 5, page 1060**). These thrust assemblies, which accommodate axial loads in one direction only, are available for shaft diameters ranging from 10 to 50 mm.

Fig. 2

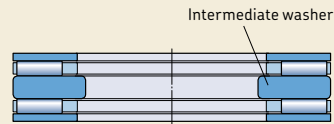

Shaft centred bearing

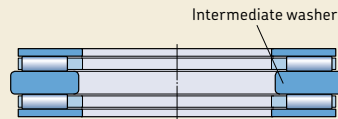

Housing centred bearing

Fig. 3

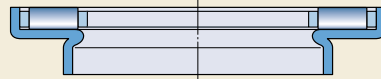

12 Needle roller thrust bearings

Combined needle roller bearing arrangements

To accommodate combined radial and axial loads, needle roller thrust bearings in the AXW series can be combined with the following radial needle roller bearings:

- drawn cup needle roller bearings with a closed end or with open ends (→ **fig. 4**)
- needle roller bearings with machined rings (→ **fig. 5**)

These arrangements provide a cost-effective and compact solution for combined loads.

Bearing washers

SKF supplies bearing washers in different designs and series. The following series can be combined with needle roller thrust bearings:

- LS series universal washers
- AS series thin universal washers
- 811 series shaft and housing washers

Bearing washers are required in applications where adjacent machine components cannot serve as raceways.

Appropriate washers are listed in the product tables and must be ordered separately, due to the number of possible combinations.

Fig. 4

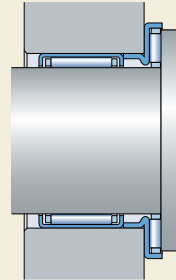
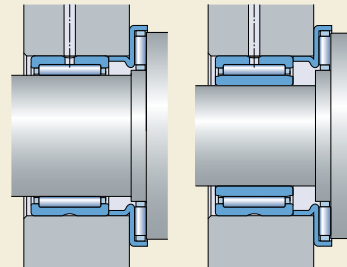

Fig. 5



Without an inner ring

With an inner ring

LS series universal washers

LS series universal washers (→ **fig. 6**) are made of hardened carbon chromium bearing steel. They can be used as shaft or housing washers for needle roller thrust bearings in the AXK series and as housing washers for bearings in the AXW series. LS series washers are available for shaft diameters ranging from 6 to 160 mm. The raceway surface is ground, while all other surfaces are turned. These washers are used for applications where accurate centring of the washers is not necessary or where slow speeds are involved. The washer face opposite the side with the chamfers is the raceway surface and should face the rollers.

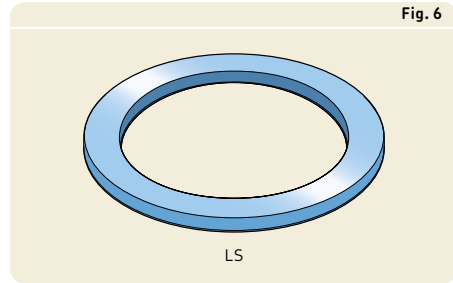

Fig. 6

AS series thin universal washers

AS series thin universal washers (→ **fig. 7**) are 1 mm thick, made of spring steel and hardened. They can be used as shaft or housing washers for needle roller thrust bearings in the AXK series and as housing washers for bearings in the AXW series. AS series washers are available for shaft diameters ranging from 4 to 160 mm. Both faces are polished and can be used as raceways. If adjacent machine components are not hardened, but have adequate stiffness and the running accuracy requirements are moderate, AS series thin universal washers can be used to provide a cost-effective bearing solution.

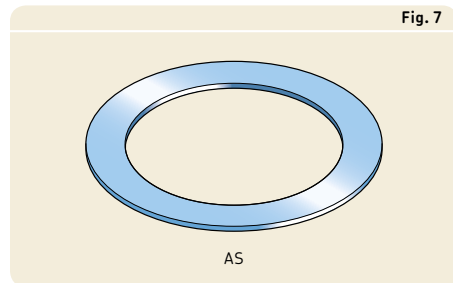

Fig. 7

811 series shaft and housing washers

Shaft and housing washers are used primarily with cylindrical roller and cage thrust assemblies. However, 811 series shaft washers (prefix WS) and housing washers (prefix GS) can also be combined with needle roller and cage thrust assemblies. These washers can be used in high-speed applications where accurate centring of the bearing washers is required.

For additional information about these washers, refer to *Cylindrical roller thrust bearings* (→ **page 1037**).

12 Needle roller thrust bearings



Cages

Depending on their series and size, SKF needle roller thrust bearings are fitted with one of the cages shown in **table 1**. Bearings in the AXW series are fitted exclusively with steel cages.

The lubricants generally used for rolling bearings do not have a detrimental effect on cage properties. However, some synthetic oils and greases with a synthetic oil base and lubricants containing a high proportion of EP additives, when used at high temperatures, can have a detrimental effect on polyamide cages. For additional information about the suitability of cages, refer to *Cages* (→ **page 37**) and *Cage materials* (→ **page 152**).

Table 1

Cages for needle roller thrust bearings

			
Material	Machined steel	Sheet steel	Glass fibre reinforced PA66
Suffix	-	-	TN

Bearing data

Dimension standards	Boundary dimensions: ISO 3031 (where standardized) Bearings in the AXW series are not standardized.
Tolerances	Tolerances, tolerance classes, standards (→ table 2, page 1064) Values (→ table 3, page 1065) Variation of gauge lot diameter of the rollers: ISO 3096, Grade 2
For additional information (→ page 132)	
Misalignment	Cannot tolerate any angular misalignment between shaft and housing or between shaft and axial support surfaces in the housing
Friction, starting torque, power loss	For calculations of the frictional moment, starting torque and power loss, contact the SKF application engineering service.
Defect frequencies	Defect frequencies can be calculated using the tools available online at skf.com/bearingcalculator .

12 Needle roller thrust bearings

Table 2

Tolerances for needle roller thrust bearings

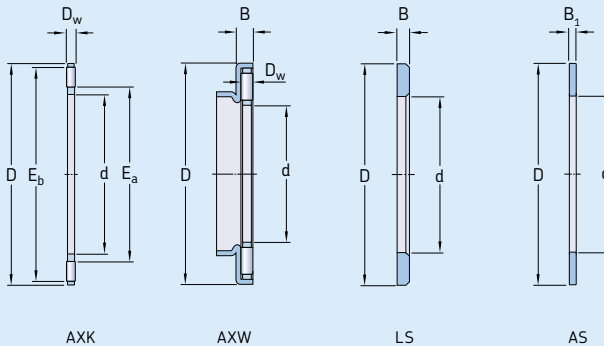

Bearing, component	Tolerance, tolerance class ¹⁾ , standard	
Dimensions		

Needle roller and cage thrust assemblies, AXK

Bore diameter	d	E12
Outside diameter	D	c13
Roller diameter	D _w	Grade 2, ISO 3096

Needle roller thrust bearings with a centring flange, AXW

Bore diameter	d	E12
Outside diameter	D	-
Thickness	B	0/-0,2 mm
Roller diameter	D _w	Grade 2, ISO 3096

Universal washers, LS

Bore diameter	d	E12
Outside diameter	D	a12
Thickness	B	h11
Axial run-out	s _i	Normal, ISO 199

Thin universal washers, AS

Bore diameter	d	E13
Outside diameter	D	e13
Thickness (1 mm)	B ₁	±0,05 mm

¹⁾ All ISO tolerance classes are valid with the envelope requirement (such as H7(Ⓔ)) in accordance with ISO 14405-1.

Table 3

ISO tolerance classes

Nominal dimension		a12 ^(E) Deviations high low		c13 ^(E) Deviations high low		e13 ^(E) Deviations high low		h11 ^(E) Deviations high low		E12 ^(E) Deviations high low		E13 ^(E) Deviations high low	
over	incl.	μm		μm		μm		μm		μm		μm	
-	3	-	-	-	-	-	-	0	-60	-	-	-	-
3	6	-	-	-	-	-	-	0	-75	+140	+20	+200	+20
6	10	-	-	-	-	-	-	0	-90	+175	+25	+245	+25
10	18	-	-	-95	-365	-32	-302	-	-	+212	+32	+302	+32
18	30	-300	-510	-110	-440	-40	-370	-	-	+250	+40	+370	+40
30	40	-310	-560	-120	-510	-50	-440	-	-	+300	+50	+440	+50
40	50	-320	-570	-130	-520	-50	-440	-	-	+300	+50	+440	+50
50	65	-340	-640	-140	-600	-60	-520	-	-	+360	+60	+520	+60
65	80	-360	-660	-150	-610	-60	-520	-	-	+360	+60	+520	+60
80	100	-380	-730	-170	-710	-72	-612	-	-	+422	+72	+612	+72
100	120	-410	-760	-180	-720	-72	-612	-	-	+422	+72	+612	+72
120	140	-460	-860	-200	-830	-85	-715	-	-	+485	+85	+715	+85
140	160	-520	-920	-210	-840	-85	-715	-	-	+485	+85	+715	+85
160	180	-580	-980	-230	-860	-85	-715	-	-	-	-	-	-
180	200	-660	-1 120	-240	-960	-100	-820	-	-	-	-	-	-

Loads

	Needle roller thrust bearings	Symbols
<p>Minimum load</p> <p>For additional information (→ page 86)</p>	<p>$F_{am} = 0,0005 C_0$</p> <p>The weight of the components supported by the bearing, particularly when the shaft is vertical, together with external forces, generally exceed the requisite minimum load. If this is not the case, the bearing must be subjected to an additional axial load by using springs or a shaft nut.</p>	<p>C_0 = basic static load rating [kN] (→ product tables)</p> <p>F_a = axial load [kN]</p> <p>F_{am} = minimum axial load [kN]</p> <p>P = equivalent dynamic bearing load [kN]</p> <p>P_0 = equivalent static bearing load [kN]</p>
<p>Equivalent dynamic bearing load</p> <p>For additional information (→ page 85)</p>	<p>$P = F_a$</p>	
<p>Equivalent static bearing load</p> <p>For additional information (→ page 88)</p>	<p>$P_0 = F_a$</p>	

Temperature limits

The permissible operating temperature for needle roller thrust bearings can be limited by:

- the dimensional stability of the bearing washers and rollers
- the cage
- the lubricant

When temperatures outside the permissible range are expected, contact the SKF application engineering service.

Bearing washers and rollers

SKF needle roller thrust bearings undergo a special heat treatment. The bearings are heat stabilized up to at least 120 °C (250 °F).

Cages

Steel cages can be used at the same operating temperatures as the bearing washers and rollers. For temperature limits of polymer cages, refer to *Cage materials* (→ **page 152**).

Lubricants

Temperature limits for SKF greases are provided under *Lubrication* (→ **page 239**). When using lubricants not supplied by SKF, the temperature limits should be evaluated according to the SKF traffic light concept (→ **page 244**).

Permissible speed

The permissible speed can be estimated using the speed ratings listed in the product tables and applying the information provided under *Speeds* (→ **page 117**).

Design of bearing arrangements

Abutment dimensions

The support surfaces on shafts and in housings should be at right angles to the shaft or housing axis and should provide uninterrupted support over the entire washer face. The abutment diameter on the shaft should be $\leq E_a$ and in the housing $\geq E_b$. Values for E_a and E_b (\rightarrow **product tables**) take the movement and position of the roller set into consideration.

To provide satisfactory radial guidance for the individual thrust bearing components, suitable tolerance classes for shafts and housings are listed in **table 4**. Radial space between the shaft and washer bore is required for housing centred washers. Shaft centred washers require radial space between the washer and housing bore.

Needle roller and cage thrust assemblies in the AXW series are generally combined with drawn cup needle roller bearings (\rightarrow **fig. 4, page 1060**) or needle roller bearings with machined rings (\rightarrow **fig. 5, page 1060**). The same housing tolerance must be selected for the centring flange as for the radial bearing.

Needle roller and cage thrust assemblies are generally shaft centred, to reduce the circumferential speed at which the cage slides against the guiding surface. This is particularly important for higher speed applications. The guiding surface should be ground.

Raceways on shafts and in housings

If the load carrying capacity of a needle roller and cage thrust assembly is to be fully exploited, the raceways on the shaft or in the housing should have the same hardness, surface finish and axial run-out as a bearing washer.

The dimensions E_a and E_b (\rightarrow **product tables**) take displacement of the roller set into consideration and should be applied when designing raceways on shafts and in housings.

For additional information, refer to *Raceways on shafts and in housings* (\rightarrow **page 210**).

Table 4

Shaft and housing tolerance classes			
Bearing component	Series	Tolerance class ¹⁾	
		Shaft centred	Housing centred
Needle roller and cage thrust assemblies	AXK	h8	–
Universal washers	LS	h8 radial space	radial space H9
Thin universal washers	AS	h8 radial space	radial space H9
Shaft washers	WS 811	h8	–
Housing washers	GS 811	–	H9

¹⁾ All ISO tolerance classes are valid with the envelope requirement (such as H7 \oplus) in accordance with ISO 14405-1.

Designation system

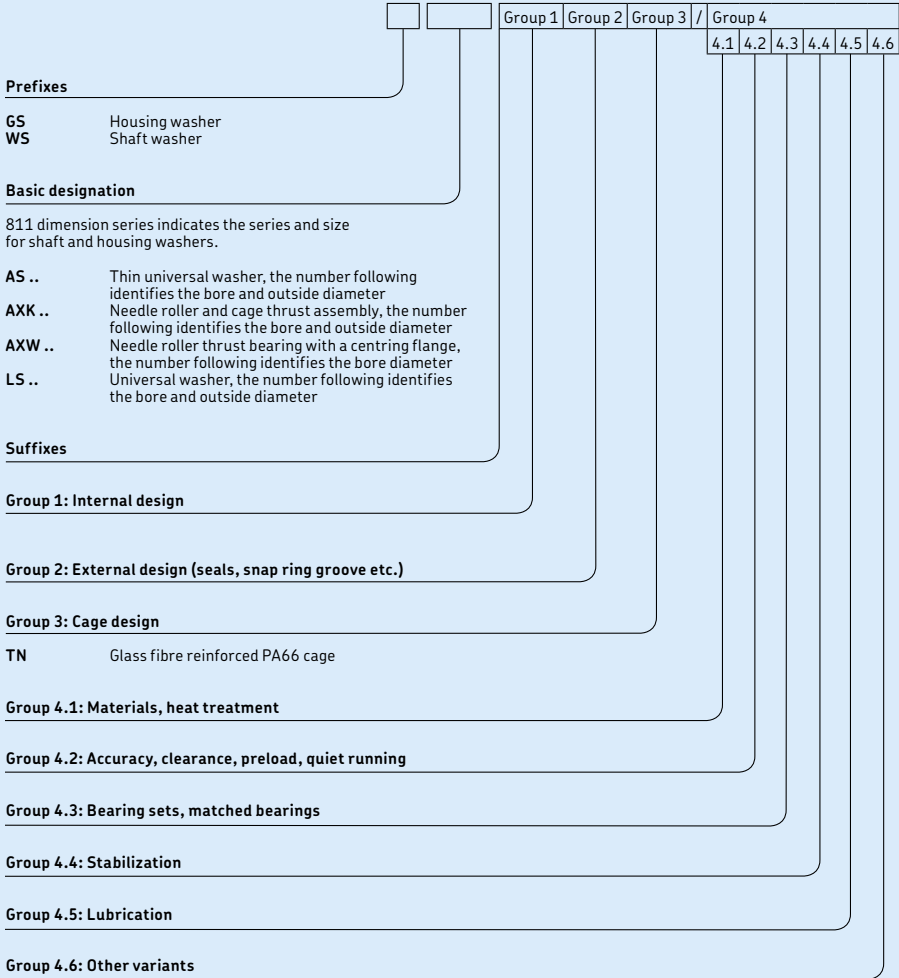

12.1 Needle roller and cage thrust assemblies and appropriate washers d 4 – 80 mm

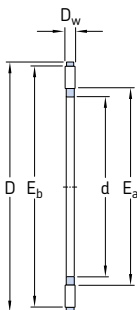

Principal dimensions					Basic load ratings		Fatigue load limit P_u	Speed ratings		Mass	Designation
d	D	D_w	E_a	E_b	dynamic C	static C_0		Reference speed	Limiting speed		
mm					kN		kN	r/min	g		-
4	14	2	5	13	4,15	8,3	0,95	7 500	15 000	0,7	AXK 0414 TN
5	15	2	6	14	4,5	9,5	1,08	6 700	14 000	0,8	AXK 0515 TN
6	19	2	7	18	6,3	16	1,86	6 000	12 000	1	AXK 0619 TN
8	21	2	9	20	7,2	20	2,32	5 600	11 000	2	AXK 0821 TN
10	24	2	12	23	8,5	26	3	5 300	10 000	3	AXK 1024
12	26	2	14	25	9,15	30	3,45	5 000	10 000	3	AXK 1226
15	28	2	17	27	10,4	37,5	4,3	4 800	9 500	4	AXK 1528
17	30	2	19	29	11	40,5	4,75	4 500	9 500	4	AXK 1730
20	35	2	22	34	12	47,5	5,6	4 300	8 500	5	AXK 2035
25	42	2	29	41	13,4	60	6,95	3 800	7 500	7	AXK 2542
30	47	2	34	46	15	72	8,3	3 600	7 000	8	AXK 3047
35	52	2	39	51	16,6	83	9,8	3 200	6 300	10	AXK 3552
40	60	3	45	58	25	114	13,7	2 800	5 600	16	AXK 4060
45	65	3	50	63	27	127	15,3	2 600	5 300	18	AXK 4565
50	70	3	55	68	28,5	143	17	2 400	5 000	20	AXK 5070
55	78	3	60	76	34,5	186	22,4	2 200	4 300	28	AXK 5578
60	85	3	65	83	37,5	232	28,5	2 200	4 300	33	AXK 6085
65	90	3	70	88	39	255	31	2 000	4 000	35	AXK 6590
70	95	4	74	93	49	255	31	1 800	3 600	60	AXK 7095
75	100	4	79	98	50	265	32,5	1 700	3 400	61	AXK 75100
80	105	4	84	103	51	280	34	1 700	3 400	63	AXK 80105

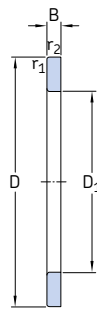
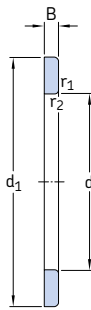
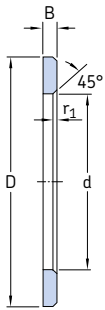

LS

AS

WS 811

GS 811

Dimensions					Masses Washers		Designations		Thin universal washer	Shaft washer	Housing washer
d	d ₁	D	D ₁	B	r _{1,2} min.	LS, WS, GS	AS	Universal washer			
mm					g		-				
4	-	14	-	-	-	-	1	-	AS 0414	-	-
5	-	15	-	-	-	-	1	-	AS 0515	-	-
6	-	19	-	2,75	0,3	6	2	LS 0619	AS 0619	-	-
8	-	21	-	2,75	0,3	6	2	LS 0821	AS 0821	-	-
10	-	24	-	2,75	0,3	8	3	LS 1024	AS 1024	-	-
12	-	26	-	2,75	0,3	9	3	LS 1226	AS 1226	-	-
15	28	28	16	2,75	0,3	9	3	LS 1528	AS 1528	WS 81102	GS 81102
17	30	30	18	2,75	0,3	9	4	LS 1730	AS 1730	WS 81103	GS 81103
20	35	35	21	2,75	0,3	13	5	LS 2035	AS 2035	WS 81104	GS 81104
25	42	42	26	3	0,6	19	7	LS 2542	AS 2542	WS 81105	GS 81105
30	47	47	32	3	0,6	22	8	LS 3047	AS 3047	WS 81106	GS 81106
35	52	52	37	3,5	0,6	29	9	LS 3552	AS 3552	WS 81107	GS 81107
40	60	60	42	3,5	0,6	40	12	LS 4060	AS 4060	WS 81108	GS 81108
45	65	65	47	4	0,6	50	13	LS 4565	AS 4565	WS 81109	GS 81109
50	70	70	52	4	0,6	55	14	LS 5070	AS 5070	WS 81110	GS 81110
55	78	78	57	5	0,6	88	18	LS 5578	AS 5578	WS 81111	GS 81111
60	85	85	62	4,75	1	97	22	LS 6085	AS 6085	WS 81112	GS 81112
65	90	90	67	5,25	1	115	24	LS 6590	AS 6590	WS 81113	GS 81113
70	95	95	72	5,25	1	123	25	LS 7095	AS 7095	WS 81114	GS 81114
75	100	100	77	5,75	1	142	27	LS 75100	AS 75100	WS 81115	GS 81115
80	105	105	82	5,75	1	151	28	LS 80105	AS 80105	WS 81116	GS 81116

12.1 Needle roller and cage thrust assemblies and appropriate washers d 85 – 160 mm

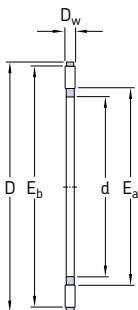

Principal dimensions					Basic load ratings		Fatigue load limit P_u	Speed ratings		Mass	Designation
d	D	D_w	E_a	E_b	dynamic C	static C_0		Refer- ence speed	Limiting speed		
mm					kN		kN	r/min	g		-
85	110	4	89	108	52	290	35,5	1 700	3 400	67	AXK 85110
90	120	4	94	118	65,5	405	49	1 500	3 000	86	AXK 90120
100	135	4	105	133	76,5	560	65,5	1 400	2 800	104	AXK 100135
110	145	4	115	143	81,5	620	72	1 300	2 600	122	AXK 110145
120	155	4	125	153	86,5	680	76,5	1 300	2 600	131	AXK 120155
130	170	5	136	167	112	830	93	1 100	2 200	205	AXK 130170
140	180	5	146	177	116	900	96,5	1 000	2 000	219	AXK 140180
150	190	5	156	187	120	950	102	1 000	2 000	232	AXK 150190
160	200	5	166	197	125	1 000	106	950	1 900	246	AXK 160200

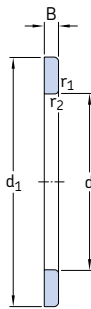
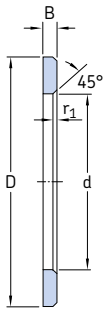

LS

AS

WS 811

GS 811

Dimensions					Masses Washers		Designations		Thin universal washer	Shaft washer	Housing washer
d	d ₁	D	D ₁	B	r _{1,2} min.	LS, WS, GS	AS	Universal washer			
mm					g		-				
85	110	110	87	5,75	1	159	29	LS 85110	AS 85110	WS 81117	GS 81117
90	120	120	92	6,5	1	234	39	LS 90120	AS 90120	WS 81118	GS 81118
100	135	135	102	7	1	350	50	LS 100135	AS 100135	WS 81120	GS 81120
110	145	145	112	7	1	385	55	LS 110145	AS 110145	WS 81122	GS 81122
120	155	155	122	7	1	415	59	LS 120155	AS 120155	WS 81124	GS 81124
130	170	170	132	9	1	663	65	LS 130170	AS 130170	WS 81126	GS 81126
140	178	180	142	9,5	1	749	79	LS 140180	AS 140180	WS 81128	GS 81128
150	188	190	152	9,5	1	796	84	LS 150190	AS 150190	WS 81130	GS 81130
160	198	200	162	9,5	1	842	89	LS 160200	AS 160200	WS 81132	GS 81132

12.2 Needle roller thrust bearings with a centring flange and appropriate washers d 10 – 50 mm

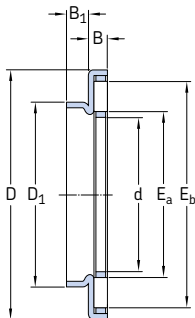

Principal dimensions								Basic load ratings		Fatigue load limit P_u	Speed ratings		Mass	Designation
d	D	D_1	B	B_1	E_a	E_b	dynamic	static	Reference speed		Limiting speed			
mm							kN	kN	kN	r/min		g	-	
10	27	14	3,2	3	12	23	8,5	26	3	4 800	10 000	8,3	AXW 10	
12	29	16	3,2	3	14	25	9,15	30	3,45	4 800	9 500	9,1	AXW 12	
15	31	21	3,2	3,5	17	27	10,4	37,5	4,3	4 500	9 000	10	AXW 15	
17	33	23	3,2	3,5	19	29	11	40,5	4,75	4 500	9 000	11	AXW 17	
20	38	26	3,2	3,5	22	34	12	47,5	5,6	4 000	8 000	14	AXW 20	
25	45	32	3,2	4	29	41	13,4	60	6,95	3 600	7 500	20	AXW 25	
30	50	37	3,2	4	34	46	15	72	8,3	3 400	7 000	22	AXW 30	
35	55	42	3,2	4	39	51	16,6	83	9,8	3 200	6 300	27	AXW 35	
40	63	47	4,2	4	45	58	25	114	13,7	2 800	5 600	39	AXW 40	
45	68	52	4,2	4	50	63	27	127	15,3	2 600	5 000	43	AXW 45	
50	73	58	4,2	4,5	55	68	28,5	143	17	2 400	4 800	49	AXW 50	

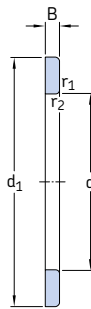
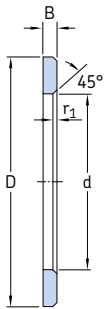

LS

AS

WS 811

Dimensions				Masses Washers		Designations		
d	d ₁ , D	B	r _{1,2} min.	LS, WS, GS	AS	Universal washer	Thin universal washer	Shaft washer
mm				g		-		
10	24	2,75	0,3	8	3	LS 1024	AS 1024	-
12	26	2,75	0,3	9	3	LS 1226	AS 1226	-
15	28	2,75	0,3	9	3	LS 1528	AS 1528	WS 81102
17	30	2,75	0,3	9	4	LS 1730	AS 1730	WS 81103
20	35	2,75	0,3	13	5	LS 2035	AS 2035	WS 81104
25	42	3	0,6	19	7	LS 2542	AS 2542	WS 81105
30	47	3	0,6	22	8	LS 3047	AS 3047	WS 81106
35	52	3,5	0,6	29	9	LS 3552	AS 3552	WS 81107
40	60	3,5	0,6	40	12	LS 4060	AS 4060	WS 81108
45	65	4	0,6	50	13	LS 4565	AS 4565	WS 81109
50	70	4	0,6	55	14	LS 5070	AS 5070	WS 81110



13 Spherical roller thrust bearings

Designs	1078	Product table	
Basic design bearings	1078	13.1 Spherical roller	
Cages	1079	thrust bearings	1090
Performance classes	1079		
SKF Explorer bearings	1079		
Bearing data	1080		
(Dimension standards, tolerances, misalignment, friction, starting torque, power loss, defect frequencies)			
Loads	1082		
(Minimum load, equivalent loads)			
Temperature limits	1084		
Permissible speed	1084		
Design of bearing arrangements	1085		
Abutment dimensions	1085		
Recessed housing bore for bearings with a stamped cage	1085		
Axial clearance	1086		
Lubrication	1086		
Mounting	1088		
Designation system	1089		



13 Spherical roller thrust bearings

Designs

SKF spherical roller thrust bearings have specially designed raceways and accommodate a large number of asymmetrical rollers. The rollers have an optimum conformity with the washer raceways to optimize load distribution along the roller length. Therefore, they can accommodate relatively high speeds, heavy axial loads in one direction and heavy radial loads. The load is transmitted between the raceways at an angle to the bearing axis (→ **fig. 1**). Spherical roller thrust bearings are self-aligning and can accommodate misalignment of the shaft relative to the housing, which can be caused, for example, by shaft deflection.

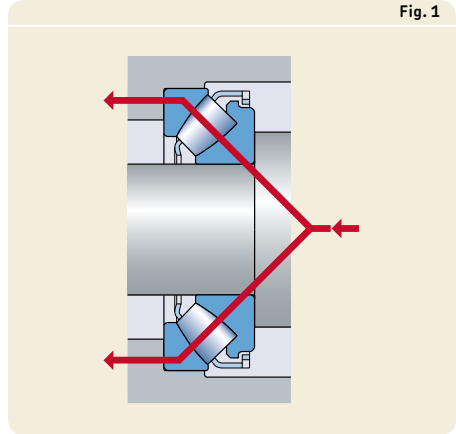

Basic design bearings

Depending on their series and size, SKF spherical roller thrust bearings are manufactured to two basic designs: bearings with no designation suffix and E design bearings.

Bearings with no designation suffix (e.g. 29272) are fitted with a machined prong-type brass cage as standard (→ **fig. 2**). The cage is guided by a sleeve held in the shaft washer bore. The shaft washer, cage and rollers form a non-separable unit.

Bearings with an E designation suffix have larger rollers and an optimized internal design for increased load carrying capacity. E design bearings up to size 68 are fitted with a stamped window-type steel cage (→ **fig. 3**), which forms a non-separable unit with the shaft washer and rollers.

E design bearings from size 72 and larger are fitted with a machined prong-type cage. This type of cage is guided by a sleeve held in the shaft washer bore. The shaft washer, cage and rollers form a non-separable unit.

More information

Bearing life and load ratings 63

Design considerations 159

Recommended fits 169

Abutment and fillet dimensions 208

Lubrication 239

Mounting, dismantling and bearing care 271

Mounting instructions for individual bearings → skf.com/mount

Cages

Cages in SKF spherical roller thrust bearings are an integral part of the bearing internal design. All SKF spherical roller thrust bearings contain a strong metal cage. This enables them to tolerate high temperatures and all lubricants.

For additional information about the suitability of cages, refer to *Cages* (→ **page 37**) and *Cage materials* (→ **page 152**).

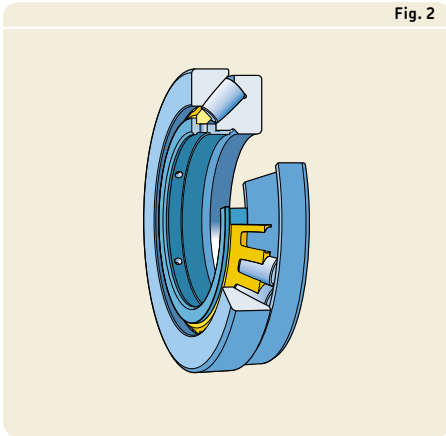

Fig. 2

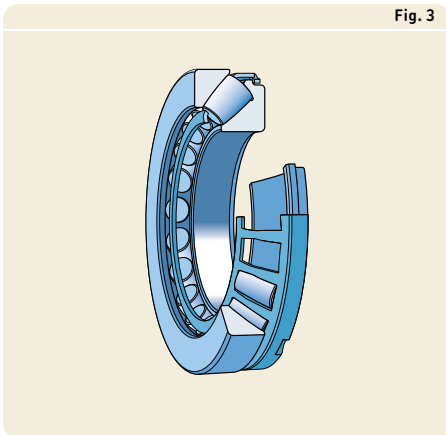

Fig. 3

Performance classes

SKF Explorer bearings

In response to the ever-demanding performance requirements of modern machinery, SKF developed the SKF Explorer performance class of rolling bearings.

SKF Explorer spherical roller thrust bearings realized this substantial improvement in performance by optimizing the internal geometry and surface finish of all contact surfaces, combining the extremely clean and homogeneous steel with a unique heat treatment, improving the cage, roller profile and the geometry of the raceways.

These improvements provide the following benefits:

- higher dynamic load carrying capacity compared to conventional design bearings
- improved wear-resistance
- reduced noise and vibration levels
- less frictional heat
- significantly extended bearing service life

SKF Explorer bearings reduce environmental impact by enabling downsizing and reducing both lubricant and energy use. Just as importantly, SKF Explorer bearings can reduce the need for maintenance and contribute to increased productivity.

SKF Explorer bearings are shown with an asterisk in the product tables. The bearings retain the designation of earlier standard bearings. However, each bearing and its box are marked with the name "SKF EXPLORER".

Bearing data

Dimension standards	Boundary dimensions: ISO 104
Tolerances	Normal Total height H: <ul style="list-style-type: none"> • for basic design bearings tolerance at least 50% tighter than ISO standard • for SKF Explorer bearings tolerance 75% tighter than ISO standard
For additional information (→ page 132)	Values: ISO 199 (→ table 10, page 144)
Misalignment	The permissible misalignment is reduced as the load increases. Guideline values for misalignment and rotating shaft washer with respect to the housing washer: table 1 . Whether these values can be fully exploited depends on the design of the bearing arrangement, the external sealing design, etc. When designing bearing arrangements with rotating housing washer in combination with misalignment or when the shaft wobbles in relation to the housing, contact the SKF application engineering service.
Friction, starting torque, power loss	Frictional moment, starting torque and power loss can be calculated as specified under <i>Friction</i> (→ page 97), or using the tools available online at skf.com/bearingcalculator . For temperature and/or cooling requirement calculations in large bearings ($d_m > 400 \text{ mm}$) ¹⁾ , vertical shaft arrangements and fully submerged conditions, contact the SKF application engineering service.
Defect frequencies	Defect frequencies can be calculated using the tools available online at skf.com/bearingcalculator .

¹⁾ d_m = bearing mean diameter [mm]
= $0,5 (d + D)$

Table 1

Permissible angular misalignment for rotating shafts

Bearing series	Permissible misalignment when bearing load $P_0^{(1)}$		
	$< 0,05 C_0$	$\geq 0,05 C_0$	$> 0,3 C_0$
–	°		
292 (E)	2	1,5	1
293 (E)	2,5	1,5	0,3
294 (E)	3	1,5	0,3

¹⁾ Refer to *Equivalent static bearing load* (→ page 1082)

Loads

Minimum load

$$F_{am} = C_r F_r + A \left(\frac{n}{1\,000} \right)^2 + F_{lub}$$

$$v n \geq 2\,000 \rightarrow F_{lub} = \frac{2 \times 10^{-9} f_0 (v n)^{2/3} [0,5 (d + D)]^3}{d}$$

$$v n < 2\,000 \rightarrow F_{lub} = \frac{3,2 \times 10^{-7} f_0 [0,5 (d + D)]^3}{d}$$

The weight of the components supported by the bearing, together with external forces, generally exceed the requisite minimum load. If this is not the case, the bearing must be subjected to an additional axial load.

However, the requisite minimum load can be neglected for bearings operating at relatively slow speeds, depending on the outside diameter (→ **diagram 1, page 1084**).

Example:

For additional information (→ **page 86**)

A 29444 E bearing is to operate at 90 r/min, from **diagram 1** with $D = 420$ mm the two lines converge below the blue line. Therefore, the minimum load requirement can be ignored.

Equivalent dynamic bearing load

$F_r \leq 0,55 F_a$ and:

- if run-out in the bearing arrangement does not affect the load distribution in the spherical roller thrust bearing
→ $P = 0,88 (F_a + X F_r)$
- if run-out in the bearing arrangement affects the load distribution in the spherical roller thrust bearing (e.g. the run-out of another bearing that induces radial forces)
→ $P = F_a + X F_r$

For additional information (→ **page 85**)

$F_r > 0,55 F_a \rightarrow$ Contact the SKF application engineering service.

Equivalent static bearing load

$F_r \leq 0,55 F_a \rightarrow P_0 = F_a + X_0 F_r$

$F_r > 0,55 F_a \rightarrow$ Contact the SKF application engineering service.

For additional information (→ **page 88**)

Symbols

A	= minimum load factor (→ product tables)
C_r	= load factor 1,8 for 292 series 2,0 for 293 series 2,2 for 294 series
D	= bearing outside diameter [mm]
d	= bearing bore diameter [mm]
f_0	= factor for lubrication method: for oil bath lubrication with a horizontal shaft and for grease lubrication: 3 for 292 series 3,5 for 293 series 4 for 294 series for oil bath lubrication with a vertical shaft and for oil jet lubrication: 6 for 292 series 7 for 293 series 8 for 294 series
F_{am}	= minimum axial load [kN]
F_{lub}	= axial load required to overcome lubricant drag [kN]
F_r	= radial load [kN]
n	= rotational speed [r/min]
P	= equivalent dynamic bearing load [kN]
P_0	= equivalent static bearing load [kN]
X	= calculation factor 1,1 for 292 series 1,2 for 293 series 1,3 for 294 series
X_0	= calculation factor 2,5 for 292 series 2,7 for 293 series 2,9 for 294 series
ν	= actual operating viscosity of the lubricant [mm ² /s]

13 Spherical roller thrust bearings

Diagram 1

Minimum load requirements for spherical roller thrust bearings

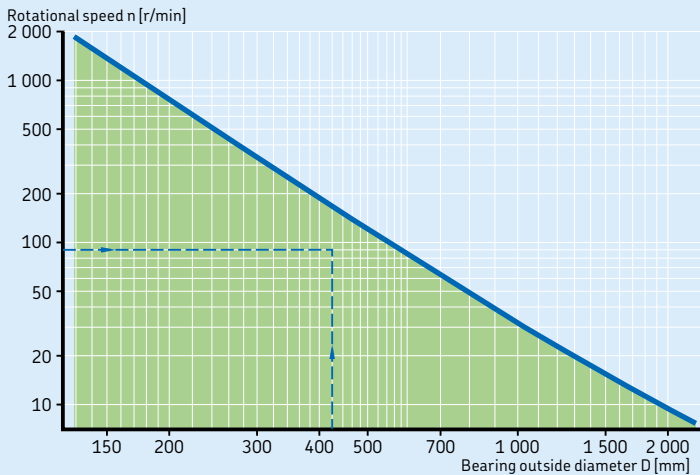

Temperature limits

The permissible operating temperature for spherical roller thrust bearings can be limited by:

- the dimensional stability of the bearing washers
- the lubricant

When temperatures outside the permissible range are expected, contact the SKF application engineering service.

Bearing washers

SKF spherical roller thrust bearings undergo a special heat treatment. The bearing washers are heat stabilized for use at temperatures up to 200 °C (390 °F) for at least 2 500 h, or for brief periods at even higher temperatures.

Lubricants

Temperature limits for SKF greases are provided under *Lubrication* (→ [page 239](#)). When using lubricants not supplied by SKF, the temperature limits should be evaluated according to the SKF traffic light concept (→ [page 244](#)).

Permissible speed

The permissible speed can be estimated using the speed ratings listed in the product tables and applying the information provided under *Speeds* (→ [page 117](#)).

Design of bearing arrangements

Abutment dimensions

The abutment dimensions $d_{a \min}$ and $D_{a \max}$ listed in the product tables apply for axial bearing loads $F_a \leq 0,1 C_0$. If the bearings are subjected to heavier loads, it may be necessary to support the shaft and housing washers over their entire side faces ($d_a = d_1$ and $D_a = D_1$). For heavy loads, where $P > 0,1 C_0$, the shaft washer bore must be fully supported by the shaft, preferably by an interference fit. Even the housing washer should be radially supported (\rightarrow fig. 4).

For additional information about dimensioning washer supports, contact the SKF application engineering service.

Recessed housing bore for bearings with a stamped cage

For bearings fitted with a stamped window-type steel cage, the housing bore must be recessed (\rightarrow fig. 5) to prevent the cage from contacting the housing during possible misalignment. SKF recommends the following guideline values for the diameter of that recess:

- $D + 15$ mm for bearings with an outside diameter $D \leq 380$ mm
- $D + 20$ mm for bearings with an outside diameter $D > 380$ mm

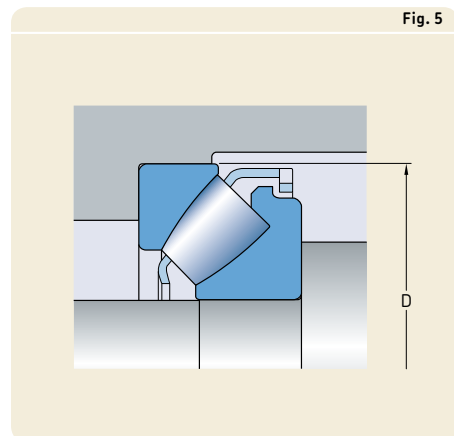
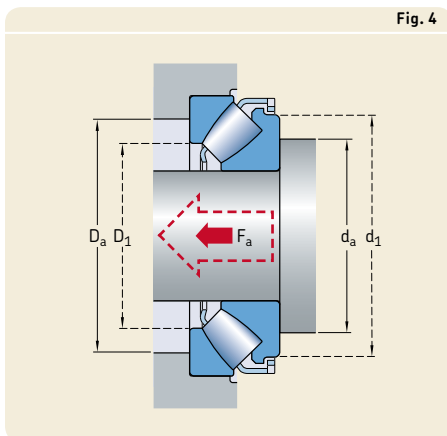

13 Spherical roller thrust bearings

Axial clearance

SKF spherical roller thrust bearings must be subjected to a minimum load (→ *Minimum load*, **page 1082**). However, at relatively slow speeds, in the zone below the blue line (→ **diagram 1**, **page 1084**) the application can be designed to operate with a small axial clearance. For these applications, bearings with a modified shaft washer (designation suffix VUQ29) should be used. Small axial clearance enables simple and cost-effective bearing arrangements e. g. for horizontal shaft applications at relatively slow speeds, as no external preload is necessary.

For additional information about bearing arrangements with axial clearance, contact the SKF application engineering service.

Lubrication

Generally, SKF spherical roller thrust bearings can be lubricated with oil or grease containing EP additives.

When lubricating with grease the roller end / flange contacts must be supplied with an adequate amount of grease. Depending on the application, this can be solved by filling the bearing and housing with grease, or by regular relubrication. For additional information, contact the SKF application engineering service.

Pumping effect in oil lubricated applications

Spherical roller thrust bearings create a pumping effect because of their internal design. The pumping effect creates a flow from the small to the large roller end face that can be taken advantage of in oil lubricated applications. The pumping action occurs in applications where the shaft is vertical (→ **fig. 6**) or horizontal (→ **fig. 7**) and should be considered when selecting the type of lubricant and sealing arrangement.

For high-speed applications that use bearings with a machined cage, SKF recommends using the oil injection lubrication method (→ **fig. 8**).

For additional information about lubricating spherical roller thrust bearings, contact the SKF application engineering service.

Fig. 6

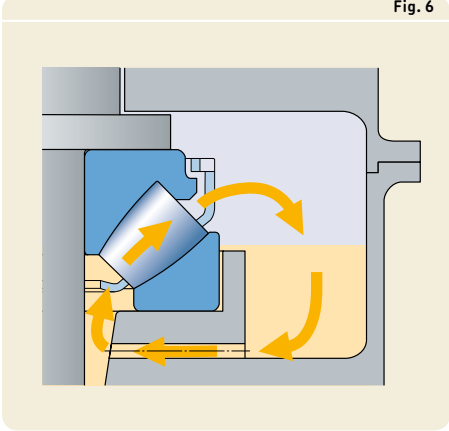

Fig. 7

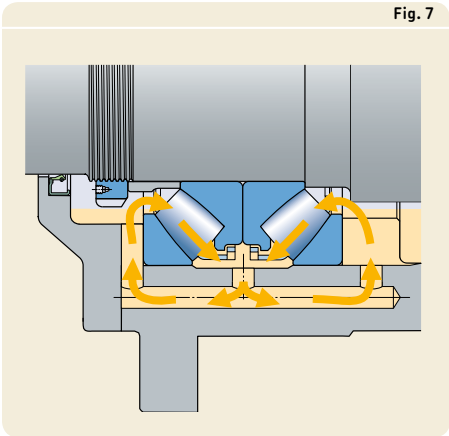
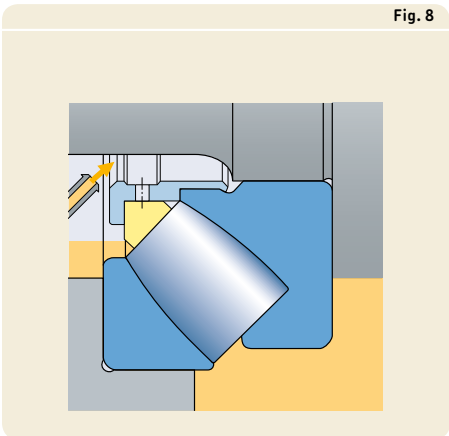

Fig. 8



13 Spherical roller thrust bearings

Mounting

SKF spherical roller thrust bearings are separable, making it possible to mount the housing washer separately from the shaft washer, cage and roller assembly.

When a spherical roller thrust bearing with a machined cage is to be replaced by an E design bearing with a stamped window-type steel cage, and axial forces are transmitted via the cage guiding sleeve, a spacer ring must be inserted between the shaft abutment and the shaft washer (→ **fig. 9**).

If an earlier B design SKF bearing, mounted with a spacer ring, is to be replaced, the spacer ring generally needs to be modified (→ **fig. 10**). The diameter d_{b2} (→ **product**

tables) of the spacer ring needs to be reduced for almost all bearing sizes.

The spacer ring must be hardened and its side faces should be ground. Appropriate spacer ring dimensions for SKF spherical roller thrust bearings are listed in the product tables.

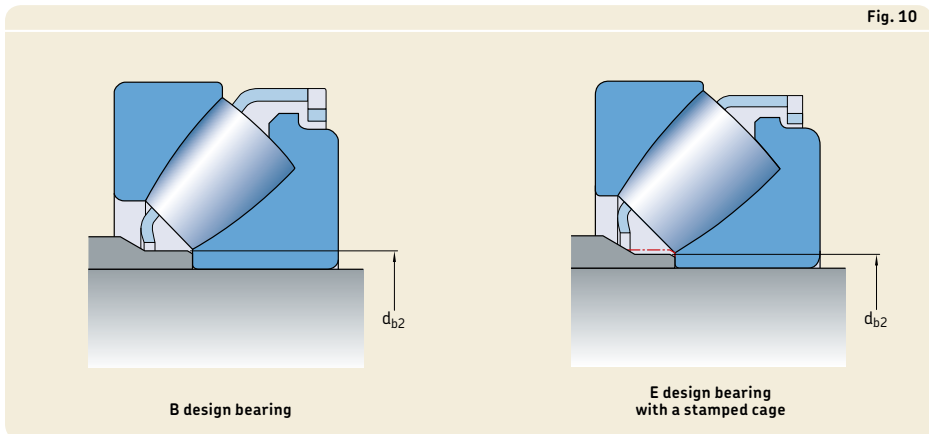
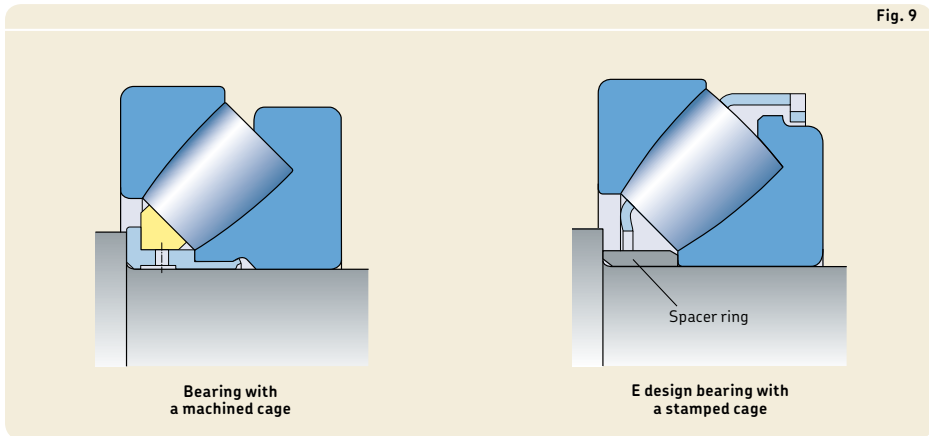

Designation system

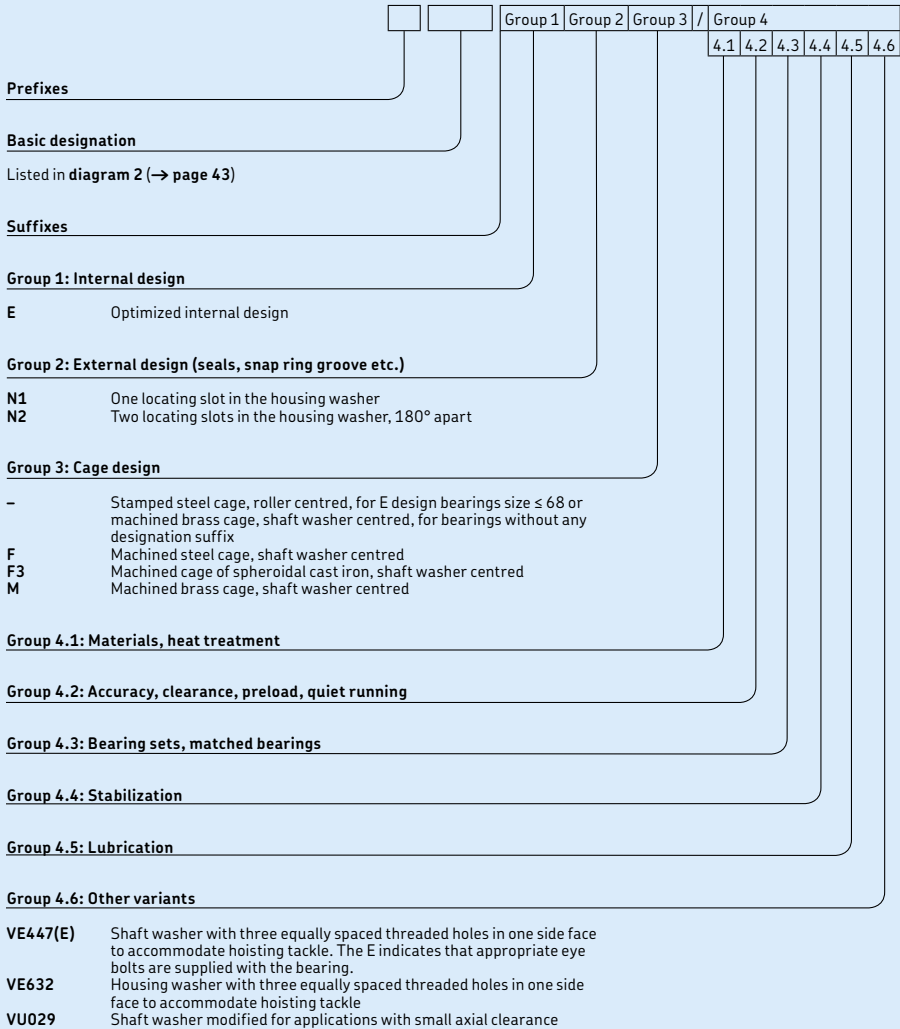

13.1 Spherical roller thrust bearings d 60 – 170 mm

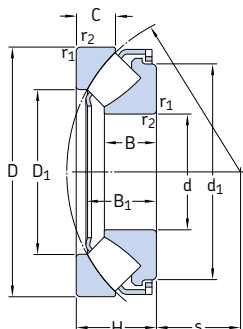

Principal dimensions			Basic load ratings		Fatigue load limit	Minimum load factor	Speed ratings		Mass	Designation
d	D	H	C	static			dynamic	Reference speed		
mm	mm	mm	mm	kN	kN	–	r/min	kg	–	
60	130	42	390	915	114	0,08	2 800	5 000	2,6	* 29412 E
65	140	45	455	1 080	137	0,11	2 600	4 800	3,2	* 29413 E
70	150	48	520	1 250	153	0,15	2 400	4 300	3,9	* 29414 E
75	160	51	600	1 430	173	0,19	2 400	4 000	4,7	* 29415 E
80	170	54	670	1 630	193	0,25	2 200	3 800	5,6	* 29416 E
85	150	39	380	1 060	129	0,11	2 400	4 000	2,75	* 29317 E
	180	58	735	1 800	212	0,31	2 000	3 600	6,75	* 29417 E
90	155	39	400	1 080	132	0,11	2 400	4 000	2,85	* 29318 E
	190	60	815	2 000	232	0,38	1 900	3 400	7,75	* 29418 E
100	170	42	465	1 290	156	0,16	2 200	3 600	3,65	* 29320 E
	210	67	980	2 500	275	0,59	1 700	3 000	10,5	* 29420 E
110	190	48	610	1 730	204	0,28	1 900	3 200	5,3	* 29322 E
	230	73	1 180	3 000	325	0,86	1 600	2 800	13,5	* 29422 E
120	210	54	765	2 120	245	0,43	1 700	2 800	7,35	* 29324 E
	250	78	1 370	3 450	375	1,1	1 500	2 600	17,5	* 29424 E
130	225	58	865	2 500	280	0,59	1 600	2 600	9	* 29326 E
	270	85	1 560	4 050	430	1,6	1 300	2 400	22	* 29426 E
140	240	60	980	2 850	315	0,77	1 500	2 600	10,5	* 29328 E
	280	85	1 630	4 300	455	1,8	1 300	2 400	23	* 29428 E
150	215	39	408	1 600	180	0,24	1 800	2 800	4,3	29320 E
	250	60	1 000	2 850	315	0,77	1 500	2 400	11	* 29330 E
	300	90	1 860	5 100	520	2,5	1 200	2 200	28	* 29430 E
160	270	67	1 180	3 450	375	1,1	1 300	2 200	14,5	* 29332 E
	320	95	2 080	5 600	570	3	1 100	2 000	32	* 29432 E
170	280	67	1 200	3 550	365	1,2	1 300	2 200	15	* 29334 E
	340	103	2 360	6 550	640	4,1	1 100	1 900	44,5	* 29434 E

* SKF Explorer bearing

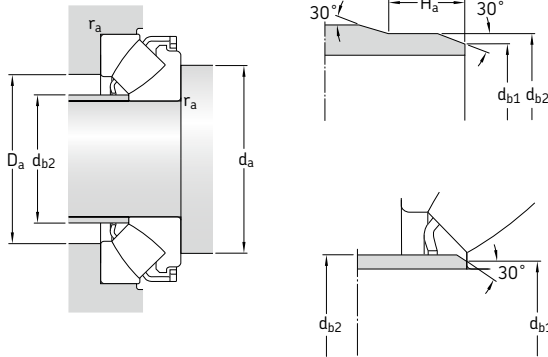

Dimensions

Abutment and fillet dimensions

d	d ₁	D ₁	B	B ₁	C	r _{1,2} min.	s	d _a min.	d _{b1} max.	d _{b2} max.	H _a min.	D _a max.	r _a max.
mm								mm					
60	112	85,5	27	36,7	21	1,5	38	90	67	67	–	107	1,5
65	120	91,5	29,5	39,8	22	2	42	100	72	72	–	117	2
70	129	99	31	41	23,8	2	44,8	105	77,5	77,5	–	125	2
75	138	106	33,5	45,7	24,5	2	47	115	82,5	82,5	–	133	2
80	147	113	35	48,1	26,5	2,1	50	120	88	88	–	141	2
85	134	110	24,5	33,8	20	1,5	50	115	90	90	–	129	1,5
	155	121	37	51,1	28	2,1	54	130	94	94	–	151	2
90	138	115	24,5	34,5	19,5	1,5	53	120	95	95	–	134	1,5
	164	128	39	54	28,5	2,1	56	135	99	99	–	158	2
100	152	128	26,2	36,3	20,5	1,5	58	130	107	107	–	147	1,5
	182	142	43	57,3	32	3	62	150	110	110	–	175	2,5
110	171	140	30,3	41,7	24,8	2	63,8	145	117	117	–	164	2
	199	156	47	64,7	34,7	3	69	165	120,5	129	–	193	2,5
120	188	155	34	48,2	27	2,1	70	160	128	128	–	181	2
	216	171	50,5	70,3	36,5	4	74	180	132	142	–	209	3
130	203	166	36,7	50,6	30,1	2,1	75,6	175	138	143	–	194	2
	234	185	54	76	40,9	4	81	195	142,5	153	–	227	3
140	216	177	38,5	54	30	2,1	82	185	148	154	–	208	2
	245	195	54	75,6	41	4	86	205	153	162	–	236	3
150	200	176	24	34,3	20,5	1,5	82	180	154	154	14	193	1,5
	223	190	38	54,9	28	2,1	87	195	158	163	–	219	2
	262	208	58	80,8	43,4	4	92	220	163	175	–	253	3
160	243	203	42	60	33	3	92	210	169	176	–	235	2,5
	279	224	60,5	84,3	45,5	5	99	235	175	189	–	270	4
170	251	215	42,2	61,1	30,5	3	96	220	178	188	–	245	2,5
	297	236	65,5	91,2	50	5	104	250	185	199	–	286	4

13.1 Spherical roller thrust bearings d 180 – 340 mm

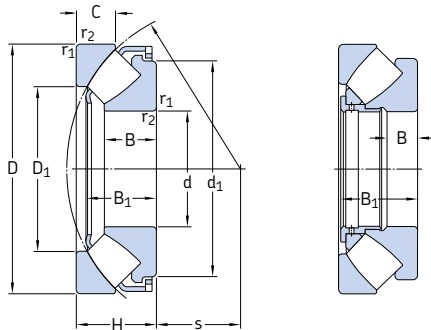

E design

Principal dimensions			Basic load ratings		Fatigue load limit	Minimum load factor	Speed ratings		Mass	Designation
d	D	H	C	static			dynamic	Reference speed		
mm	mm	mm	mm	kN	kN	-	r/min	kg	-	
180	250	42	495	2 040	212	0,4	1 600	2 600	5,8	29236 E
	300	73	1 430	4 300	440	1,8	1 200	2 000	19,5	* 29336 E
	360	109	2 600	7 350	710	5,1	1 000	1 800	52,5	* 29436 E
190	320	78	1 630	4 750	490	2,1	1 100	1 900	23,5	* 29338 E
	380	115	2 850	8 000	765	6,1	950	1 700	60,5	* 29438 E
200	280	48	656	2 650	285	0,67	1 400	2 200	9,3	29240 E
	340	85	1 860	5 500	550	2,9	1 000	1 700	28,5	* 29340 E
	400	122	3 200	9 000	850	7,7	850	1 600	72	* 29440 E
220	300	48	690	3 000	310	0,86	1 300	2 200	10	29244 E
	360	85	2 000	6 300	610	3,8	1 000	1 700	31	* 29344 E
	420	122	3 350	9 650	900	8,8	850	1 500	75	* 29444 E
240	340	60	799	3 450	335	1,1	1 100	1 800	16,5	29248 E
	380	85	2 040	6 550	630	4,1	1 000	1 600	35,5	* 29348 E
	440	122	3 400	10 200	930	9,9	850	1 500	80	* 29448 E
260	360	60	817	3 650	345	1,3	1 100	1 700	18,5	29252 E
	420	95	2 550	8 300	780	6,5	850	1 400	49	* 29352 E
	480	132	4 050	12 900	1 080	16	750	1 300	105	* 29452 E
280	380	60	863	4 000	375	1,5	1 000	1 700	19,5	29256 E
	440	95	2 550	8 650	800	7,1	850	1 400	53	* 29356 E
	520	145	4 900	15 300	1 320	22	670	1 200	135	* 29456 E
300	420	73	1 070	4 800	465	2,2	900	1 400	30,5	29260 E
	480	109	3 100	10 600	930	11	750	1 200	75	* 29360 E
	540	145	5 000	16 600	1 340	24	670	1 200	140	* 29460 E
320	440	73	1 110	5 100	465	2,5	850	1 400	33	29264 E
	500	109	3 350	11 200	1 000	12	750	1 200	78	* 29364 E
	580	155	5 700	19 000	1 530	32	600	1 100	175	* 29464 E
340	460	73	1 130	5 400	480	2,8	850	1 300	33,5	29268 E
	540	122	2 710	11 000	950	11	600	1 100	105	29368 E
	620	170	6 700	22 400	1 760	46	560	1 000	220	* 29468 E

* SKF Explorer bearing

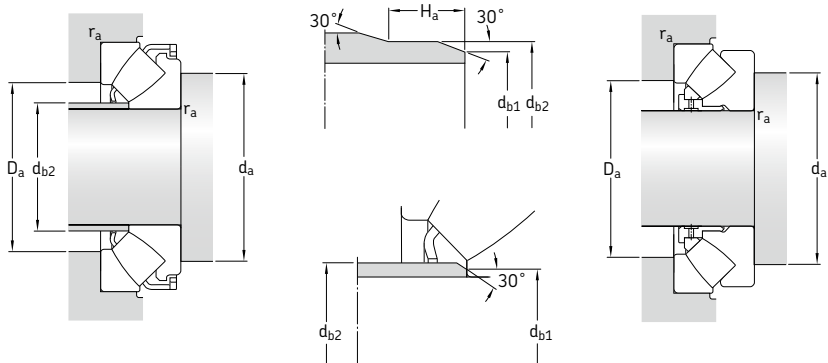

Dimensions

Abutment and fillet dimensions

d	d ₁ ~	D ₁ ~	B	B ₁	C	r _{1,2} min.	s	d _a min.	d _{b1} max.	d _{b2} max.	H _a min.	D _a max.	r _a max.
mm								mm					
180	234	208	26	36,9	22	1,5	97	210	187	187	14	226	1,5
	270	227	46	66,2	35,5	3	103	235	189	195	-	262	2,5
	315	250	69,5	96,4	53	5	110	265	196	210	-	304	4
190	285	244	49	71,3	36	4	110	250	200	211	-	280	3
	332	265	73	101	55,5	5	117	280	207	223	-	321	4
200	260	233	30	43,4	24	2	108	235	206	207	17	253	2
	304	257	53,5	76,7	40	4	116	265	211	224	-	297	3
	350	278	77	107,1	59,4	5	122	295	217,5	234	-	337	4
220	280	252	30	43,4	24,5	2	117	255	224,5	227	17	271	2
	326	274	55	77,7	41	4	125	285	229	240	-	316	3
	371	300	77	107,4	58,5	6	132	315	238	254	-	358	5
240	330	283	37,5	57	30	2,1	130	290	-	-	-	308	2
	345	296	54	77,8	40,5	4	135	305	249	259	-	336	3
	391	322	76	107,1	59	6	142	335	258	276	-	378	5
260	350	302	37,5	57	30	2,1	139	310	-	-	-	326	2
	382	324	61	86,6	46	5	148	335	273	286	-	370	4
	427	346	86	119	63	6	154	365	278	296	-	412	5
280	370	323	37,5	57	30,5	2,1	150	325	-	-	-	347	2
	401	343	62	86,7	45,5	5	158	355	293	305	-	390	4
	464	372	95	129,9	70	6	166	395	300	320	-	446	5
300	405	353	42,5	69	38	3	162	360	-	-	-	380	2,5
	434	372	70	98,9	51	5	168	385	313	329	-	423	4
	485	392	95	130,3	70,5	6	175	415	319	340	-	465	5
320	430	372	42,7	69	38	3	172	380	-	-	-	400	2,5
	454	391	68	97,8	53	5	180	405	332	347	-	442	4
	520	422	102	139,4	74,5	7,5	191	450	344	367	-	500	6
340	445	395	43	69	37,5	3	183	400	-	-	-	422	2,5
	520	428	76	117	59,5	5	192	440	-	-	-	479	4
	557	445	112	151,4	84	7,5	201	475	363	386	-	530	6

13.1 Spherical roller thrust bearings d 360 – 560 mm

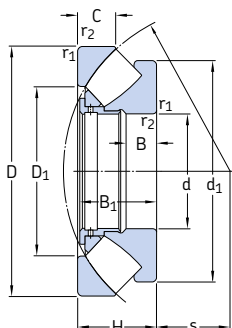

Principal dimensions			Basic load ratings		Fatigue load limit	Minimum load factor	Speed ratings		Mass	Designation
d	D	H	C	C ₀	P _u	A	Reference speed	Limiting speed	kg	-
mm			kN		kN	-	r/min		kg	-
360	500	85	1 460	6 800	585	4,4	750	1 200	52	29272
	560	122	2 760	11 600	980	13	600	1 100	110	29372
	640	170	6 200	21 200	1 630	41	560	950	230	* 29472 EM
380	520	85	1 580	7 650	655	5,6	700	1 100	53	29276
	600	132	3 340	14 000	1 160	19	530	1 000	140	29376
	670	175	6 800	24 000	1 860	53	530	900	260	* 29476 EM
400	540	85	1 610	8 000	695	6,1	700	1 100	55,5	29280
	620	132	3 450	14 600	1 200	20	530	950	150	29380
	710	185	7 650	26 500	1 960	62	480	850	310	* 29480 EM
420	580	95	1 990	9 800	815	9,1	630	1 000	75,5	29284
	650	140	3 740	16 000	1 290	24	500	900	170	29384
	730	185	7 800	27 500	2 080	69	480	850	325	* 29484 EM
440	600	95	2 070	10 400	850	10	630	1 000	78	29288
	680	145	5 200	19 300	1 560	34	530	850	180	* 29388 EM
	780	206	9 000	32 000	2 320	91	430	750	410	* 29488 EM
460	620	95	2 070	10 600	865	11	600	950	81	29292
	710	150	4 310	19 000	1 500	34	450	800	215	29392
	800	206	9 300	33 500	2 450	100	430	750	425	* 29492 EM
480	650	103	2 350	11 800	950	13	560	900	98	29296
	730	150	4 370	19 600	1 530	36	450	800	220	29396
	850	224	9 550	39 000	2 800	140	340	670	550	29496 EM
500	670	103	2 390	12 500	1 000	15	560	900	100	292/500
	750	150	4 490	20 400	1 560	40	430	800	235	293/500
	870	224	9 370	40 000	2 850	150	340	670	560	294/500 EM
530	710	109	3 110	15 300	1 220	22	530	850	115	292/530 EM
	800	160	5 230	23 600	1 800	53	400	750	270	293/530
	920	236	10 500	44 000	3 100	180	320	630	650	294/530 EM
560	750	115	2 990	16 000	1 220	24	480	800	140	292/560
	980	250	12 000	51 000	3 550	250	300	560	810	294/560 EM

* SKF Explorer bearing

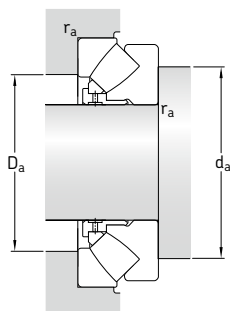
Dimensions
Abutment and fillet dimensions

d	d ₁	D ₁	B	B ₁	C	r _{1,2} min.	s	d _a min.	D _a max.	r _a max.
mm								mm		
360	485	423	49,5	81	44	4	195	430	453	3
	540	448	76	117	59,5	5	202	460	500	4
	580	474	109	164	83,5	7,5	210	495	550	6
380	505	441	53,5	81	42	4	202	450	473	3
	580	477	83,5	127	63,5	6	216	495	535	5
	610	494	114	168	87,5	7,5	222	525	580	6
400	526	460	53	81	42,2	4	212	470	493	3
	596	494	83	127	64	6	225	510	550	5
	645	525	120	178	89,5	7,5	234	550	615	6
420	564	489	61	91	46	5	225	500	525	4
	626	520	88	135	67,5	6	235	535	580	5
	665	545	121	178	90,5	7,5	244	575	635	6
440	585	508	61	91	46,5	5	235	520	545	4
	626	540	91	140	70,5	6	249	560	605	5
	710	577	133	199	101	9,5	257	605	675	8
460	605	530	61,5	91	46	5	245	540	565	4
	685	567	94	144	72,5	6	257	585	630	5
	730	596	133	199	101,5	9,5	268	630	695	8
480	635	556	62,5	99	53,5	5	259	570	595	4
	705	591	93	144	73,5	6	270	610	655	5
	770	625	147	216	108	9,5	280	660	735	8
500	654	574	62,5	99	53,5	5	268	585	615	4
	725	611	92,5	144	74	6	280	630	675	5
	795	648	145	216	110	9,5	290	685	755	8
530	675	608	66	105	56	5	285	620	655	4
	772	648	102,5	154	76	7,5	295	670	715	6
	840	686	152	228	116	9,5	308	725	800	8
560	732	644	68	111	61	5	302	655	685	4
	890	727	165	241	122	12	328	770	850	10

13.1

13.1 Spherical roller thrust bearings d 600 – 1 600 mm

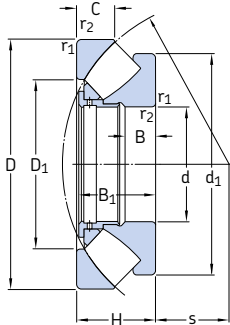

Principal dimensions			Basic load ratings		Fatigue load limit P_u	Minimum load factor A	Speed ratings		Mass	Designation
d	D	H	C	dynamic			static	Reference speed		
mm			kN		kN	-	r/min		kg	-
600	800	122	3 740	18 600	1 460	33	450	700	170	292/600 EM
	1 030	258	13 100	56 000	4 000	300	280	530	845	294/600 EM
630	850	132	4 770	23 600	1 800	53	400	670	210	292/630 EM
	950	190	8 450	38 000	2 900	140	320	600	485	293/630 EM
	1 090	280	14 400	62 000	4 150	370	260	500	1 040	294/630 EM
670	900	140	4 200	22 800	1 660	49	380	630	255	292/670
	1 150	290	15 400	68 000	4 500	440	240	450	1 210	294/670 EM
710	1 060	212	9 950	45 500	3 400	200	280	500	610	293/710 EM
	1 220	308	17 600	76 500	5 000	560	220	430	1 500	294/710 EF
750	1 000	150	6 100	31 000	2 320	91	340	560	325	292/750 EM
	1 120	224	9 370	45 000	3 050	190	260	480	770	293/750
	1 280	315	18 700	85 000	5 500	690	200	400	1 650	294/750 EF
800	1 060	155	6 560	34 500	2 550	110	320	530	380	292/800 EM
	1 180	230	9 950	49 000	3 250	230	240	450	865	293/800
	1 360	335	20 200	93 000	5 850	820	190	360	2 030	294/800 EF
850	1 120	160	6 730	36 000	2 550	120	300	500	425	292/850 EM
	1 440	354	23 900	108 000	7 100	1 100	170	340	2 390	294/850 EF
900	1 180	170	7 820	42 500	3 000	170	280	450	475	292/900 EM
	1 520	372	26 700	122 000	7 200	1 400	160	300	2 650	294/900 EF
950	1 250	180	8 280	45 500	3 100	200	260	430	600	292/950 EM
	1 600	390	28 200	132 000	7 800	1 700	140	280	3 070	294/950 EF
1 000	1 670	402	31 100	140 000	8 650	1 900	130	260	3 390	294/1000 EF
1 060	1 400	206	10 500	58 500	3 750	330	220	360	860	292/1060 EF
	1 770	426	33 400	156 000	8 500	2 300	120	240	4 280	294/1060 EF
1 180	1 520	206	10 900	64 000	3 750	390	220	340	950	292/1180 EF
1 250	1 800	330	24 800	129 000	7 500	1 600	130	240	2 770	293/1250 EF
1 600	2 280	408	36 800	200 000	11 800	3 800	90	160	5 380	293/1600 EF

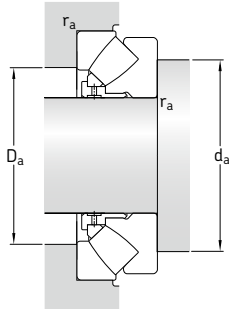

Dimensions

Abutment and fillet dimensions

d	d ₁	D ₁	B	B ₁	C	r _{1,2} min.	s	d _a min.	D _a max.	r _a max.
mm								mm		
600	760	688	74	117	60	5	321	700	735	4
	940	769	170	249	128	12	349	815	900	10
630	810	723	85	127	62	6	338	740	780	5
	880	761	122	183	92	9,5	359	795	860	8
	995	815	181	270	137	12	365	860	950	10
670	880	773	84	135	73	6	361	790	825	5
	1045	864	188	280	141	15	387	905	1000	12
710	985	855	134	205	103	9,5	404	890	960	8
	1110	917	199	298	149	15	415	965	1070	12
750	950	858	93	144	74	6	409	880	925	5
	1086	910	139	216	109	9,5	415	935	1000	8
	1170	964	207	305	153	15	436	1015	1120	12
800	1010	911	97	149	77	7,5	434	935	980	6
	1146	965	144	222	111	9,5	440	995	1060	8
	1250	1034	213	324	165	15	462	1080	1185	12
850	1060	967	95	154	82	7,5	455	980	1030	6
	1315	1077	236	342	172	15	507	1160	1270	12
900	1136	1020	105	164	85	7,5	487	1045	1100	6
	1394	1137	247	360	186	15	518	1215	1320	12
950	1185	1081	111	174	88	7,5	507	1095	1155	6
	1470	1209	255	377	191	15	546	1275	1400	12
1000	1531	1270	262	389	190	15	599	1350	1490	12
1060	1325	1211	125	199	100	9,5	566	1225	1290	8
	1615	1349	274	412	207	15	610	1410	1555	12
1180	1450	1331	125	199	101	9,5	625	1345	1410	8
1250	1685	1474	213	319	161	12	698	1540	1640	10
1600	2130	1885	259	395	195	19	894	1955	2090	15



14 Track runner bearings

Designs and variants	1100	Design of associated components . . .	1120
Cam rollers	1100	Pins	1120
Single row cam rollers	1100	Attachment holes for studs	1120
Double row cam rollers	1100	Support surfaces	1120
Support rollers	1101	Cam rollers	1120
Support rollers without flange rings .	1101	Support rollers	1120
Support rollers with flange rings . . .	1102	Cam followers	1120
Cam followers	1104	Guide flanges for cam rollers	1121
KR design cam followers	1105	Axial gap	1121
NUKR .. A design cam followers	1107	Mounting	1122
PWKR ...2RS design cam followers . .	1107	Support rollers	1122
Accessories	1109	Cam followers	1122
Cages	1111	Designation system	1124
Lubrication	1112	Product tables	
Bearing data	1115	14.1 Single row cam rollers	1126
(Dimension standards, profile of the outer ring running surface, tolerances, internal clearance, defect frequencies)		14.2 Double row cam rollers	1128
Loads	1117	14.3 Support rollers without flange rings, without an inner ring	1130
(Dynamic loads, static loads, axial loads, minimum load, equivalent loads)		14.4 Support rollers without flange rings, with an inner ring	1132
Temperature limits	1119	14.5 Support rollers with flange rings, with an inner ring	1134
Speed limits	1119	14.6 Cam followers	1140



Designs and variants

Track runner bearings are designed to run on all types of tracks and to be used in cam drives, conveyor systems, etc. These bearings have a thick-walled outer ring, which enables them to accommodate high radial loads, while reducing distortion and bending stresses.

The outer ring running surface is crowned as standard. This is beneficial for applications where angular misalignment relative to the track may occur or where edge stresses need to be minimized. With the exception of single row cam rollers, track runner bearings are also available with a cylindrical (flat) outer ring running surface.

SKF supplies track runner bearings greased, sealed and ready to mount.

SKF supplies track runner bearings in many different types and designs, and for a wide variety of operating conditions and applications. The assortment comprises:

- cam rollers, internal design based on ball bearings
- support rollers, internal design based on needle or cylindrical roller bearings
- cam followers, internal design based on needle or cylindrical roller bearings

More information

Bearing life and load ratings.	63
Design considerations	159
Lubrication	239
Mounting, dismounting and bearing care	271

Cam rollers

Single row cam rollers

SKF single row cam rollers (→ fig. 1) are based on deep groove ball bearings in the 62 series. They are supplied greased and capped with a sheet steel reinforced NBR contact seal on both sides.

Double row cam rollers

SKF double row cam rollers (→ fig. 2) are based on double row angular contact ball bearings in the 32 dimension series and have a 30° contact angle. They are supplied greased and capped with a sheet steel shield on both sides, which extends into a recess on the inner ring.

Fig. 1

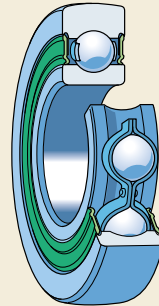
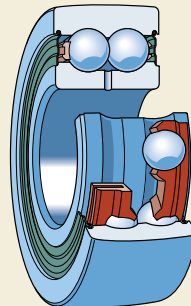

Fig. 2



Support rollers

Support rollers without flange rings

SKF support rollers without flange rings (→ **fig. 3**) are designed for applications where associated components limit axial movement of the outer ring. Based on needle roller bearings, these support rollers are available with or without an inner ring. Support rollers with an inner ring have an inner ring that is slightly wider than the outer ring to avoid axial clamping of the outer ring. Support rollers without an inner ring are intended for arrangements where the pin or shaft is hardened and ground.

STO and RSTO design support rollers

STO design support rollers have an inner ring, while RSTO design support rollers do not have an inner ring (→ **fig. 4**). Both designs are only available open (without seals). The components can be mounted separately, but the outer ring and the needle roller and cage assembly must always be kept together as supplied.

NA 22...2RS and RNA 22...2RS design support rollers

NA 22...2RS design support rollers have an inner ring, while RNA 22...2RS design support rollers do not have an inner ring (→ **fig. 5**). The needle roller and cage assembly is guided axially between two integral flanges in the outer ring to form a non-separable unit. The inner ring of NA 22...2RS design support rollers can be mounted separately from the outer ring, roller and cage assembly. Both designs are supplied greased and capped with a sheet steel reinforced NBR contact seal on both sides.

Fig. 3

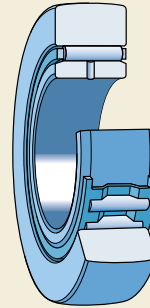

Fig. 4

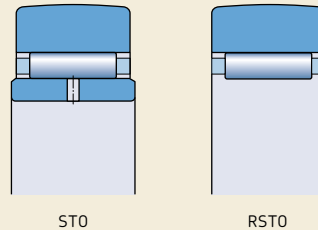
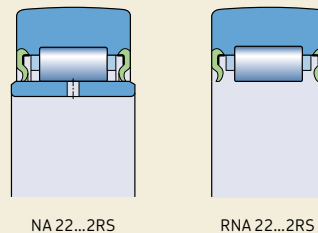

Fig. 5



14 Track runner bearings

Support rollers with flange rings

Support rollers with flange rings are non-separable units, designed for applications where there are axial loads, but no lateral (axial) support surfaces (→ **fig. 6**). These axial loads, which are induced when shafts are not horizontal or aligned properly, are accommodated by the flange rings. Depending on the design of the support rollers, the flange rings are pressed-on (NATR and NATV designs) or loose (NUTR, PWTR and NNTR designs).

NATR and NATV design support rollers

NATR design support rollers are fitted with a needle roller and cage assembly, while NATV design support rollers have a full complement of needle rollers (→ **fig. 7**). The outer rings of both designs are guided axially by pressed-on flange rings. The narrow gap between the flange rings and the outer ring serves as a gap-type seal.

Both designs are also available with an axial sliding ring on both sides, identified by the designation suffix PPA (→ **fig. 8**). The axial sliding rings are made of PA66. In the radial direction, the sliding ring forms a narrow labyrinth seal with the outer ring, to protect against coarse contaminants. In the axial direction, the sliding ring serves as a contact seal to reliably retain grease in the bearing. This improves the lubrication conditions in the bearing, keeps friction and frictional heat low, and extends grease life.

Support rollers with axial sliding rings can accommodate somewhat heavier axial loads than those without axial sliding rings. Axial loads are induced when operating in an inclined or tilted position.

Fig. 6

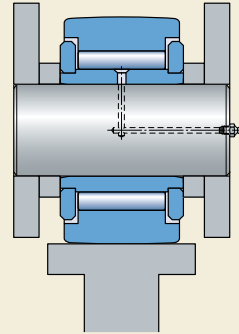
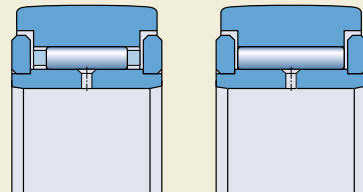

Fig. 7



NATR

NATV

Fig. 8

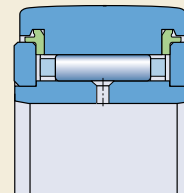

NATR..PPA

NUTR .. A design support rollers

NUTR .. A design support rollers (→ **fig. 9**) are based on double row, full complement cylindrical roller bearings without an integral flange between the two roller sets. The outer ring has two integral flanges to guide the roller sets axially. A loose flange ring on both sides of the inner ring provides axial guidance for the outer ring via the roller sets. This enables NUTR .. A design support rollers to accommodate relatively heavy axial loads that are induced when operating in an inclined or tilted position.

A sheet metal angle ring is pressed into the outer ring shoulder on both sides and forms an effective labyrinth seal. The angle rings extend over the flange rings, making the bearing non-separable.

If heavy shock loads occur, support rollers with a reinforced outer ring should be used. These are identified by a bearing designation that has a four- or five-digit number instead of a two-digit number, e.g. NUTR 50110 A.

PWTR ...2RS design support rollers

PWTR ...2RS design support rollers (→ **fig. 10**) are based on double row, full complement cylindrical roller bearings. Three integral flanges in the outer ring guide the two roller sets axially. A loose flange ring on both sides of the inner ring provides axial guidance for the outer ring via the roller sets. This, together with the relatively large grease quantity between the two roller sets, enable PWTR ...2RS design support rollers to accommodate relatively heavy constant axial loads that are induced when operating in an inclined or tilted position.

PWTR ...2RS design support rollers are supplied with an NBR contact seal on both sides. The seals are integral with the sheet metal angle rings and press against the flange rings. The angle rings are pressed into the outer ring shoulder. They extend over the flange rings, making the bearing non-separable.

If heavy shock loads occur, support rollers with a reinforced outer ring should be used. These are identified by a bearing designation that has a four- or five-digit number instead of a two-digit number, e.g. PWTR 50110.2RS.

Fig. 9

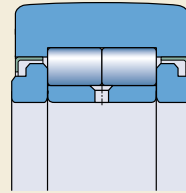

NUTR .. A

Fig. 10

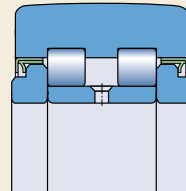

PWTR ...2RS

14 Track runner bearings

NNTR ...2ZL design support rollers

NNTR ...2ZL design support rollers (→ **fig. 11**) are based on double row, full complement cylindrical roller bearings. They are designed to accommodate very heavy radial loads. Three integral flanges in the outer ring axially guide the two roller sets. A loose flange ring on both sides of the inner ring provides axial guidance for the outer ring via the roller sets. This, together with the relatively large grease quantity between the two roller sets, enable NNTR ...2ZL design support rollers to accommodate relatively heavy constant axial loads that are induced when operating in an inclined or tilted position.

NNTR ...2ZL design support rollers are fitted with a lamellar seal on both sides. The seals are inserted into recesses in the shoulders of the flange rings and the outer ring, making the bearing non-separable.

Cam followers

Instead of an inner ring, cam followers have a solid stud (pin) that is threaded so that the cam follower can be quickly and easily attached to appropriate machine components by means of a hexagonal nut.

SKF cam followers are available in three basic designs:

- KR design
- NUKR design
- PWKR design

All three cam follower designs have the same main dimensions. The differences are in their internal design, which make them suitable for various operating conditions. In contrast to ball and roller bearings, where the bearing size refers to the bore diameter d , for cam followers the size refers to their outside diameter D .

All designs are available with a concentric seat (→ **fig. 12**) or an eccentric collar (→ **fig. 13**) on the stud. An eccentric collar, which has a shrink-fit onto the stud, enables less stringent positioning tolerances to be specified for associated components. The values for the adjustable eccentricity are listed in the product tables. An eccentric collar is identified by the letter E at the end of the basic designation.

Fig. 11

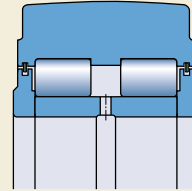

NNTR ...2ZL

Fig. 12

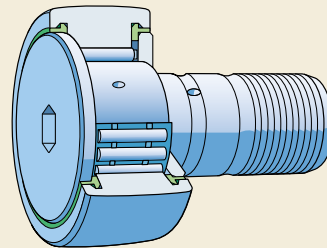
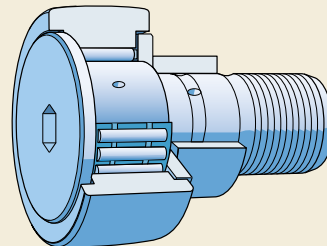

Fig. 13



KR design cam followers

KR design cam followers are fitted with a needle roller and cage assembly. They are also available with a full complement needle roller set (→ **fig. 14**), which is identified by the letter V at the end of the basic designation. The outer ring is axially guided by the pressed-on flange ring and the head of the stud, which also serves as an integral flange.

KR design cam followers without a designation suffix or with the designation suffix B (→ **fig. 15**) have a narrow gap between the outer ring and the two flanges that serves as a gap-type seal.

Fig. 14

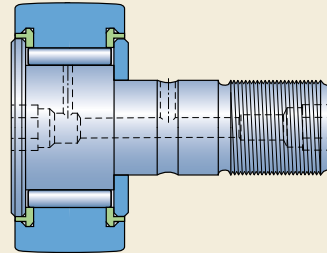

KRV .. PPA, size ≥ 30

Fig. 15

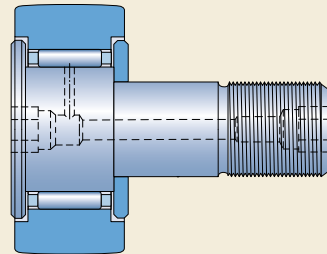

KR .. B, sizes 22 and 26

14 Track runner bearings

Fig. 16

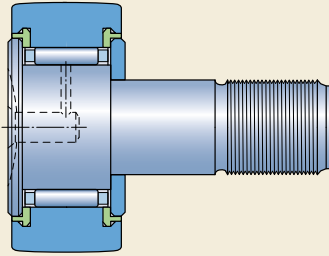

KR.. PPA, sizes 16 and 19

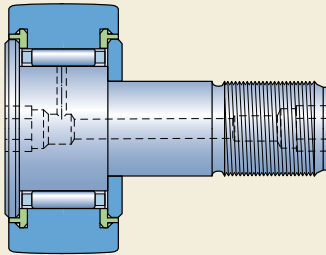

KR.. PPA, sizes 22 and 26

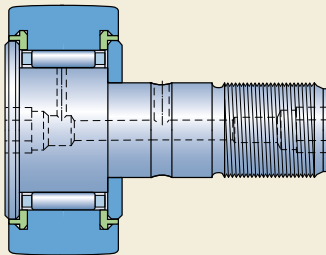

KR.. PPA, size ≥ 30

KR design cam followers are also available with an axial sliding ring made of PA66 on both sides, identified by the designation suffix PPA (→ fig. 16) or PPSKA (→ fig. 17). In the radial direction, the sliding ring forms a narrow labyrinth seal with the outer ring to protect against coarse contaminants. In the axial direction, the sliding ring serves as a contact seal to reliably retain grease in the bearing. This improves the lubrication conditions in the bearing, keeps friction and frictional heat low, and extends grease life.

Cam followers with axial sliding rings can accommodate somewhat heavier axial loads than those without axial sliding rings. Axial loads are induced when operating in an inclined or tilted position.

KR design cam followers, sizes 16 and 19, either without a designation suffix or with the designation suffix PPA have one slot in the head of the stud that enables the stud to be held in place by a screwdriver during mounting. In the centre of that slot is a relubrication hole for a press-in grease fitting or a plug if relubrication is not required (→ *Accessories*, page 1109). SKF also supplies these two sizes with a hexagonal recess in the head of the stud. They are fitted with an axial sliding ring on both sides and are identified by the designation suffix PPSKA (→ fig. 17).

KR design cam followers with the designation suffix B, sizes 22 and larger, have a hexagonal recess at each end of the stud (→ fig. 15, page 1105), enabling the cam follower to be held in place by a hexagonal key (Allen wrench)

Fig. 17

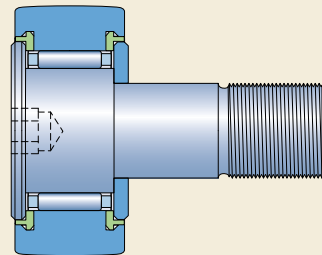

KR.. PPSKA

during mounting. In the centre of each hexagon is a relubrication hole for a press-in grease fitting, if needed. Sizes 35 and larger can accommodate adapters from a central lubrication system (→ *Accessories*, **page 1109**).

NUKR .. A design cam followers

NUKR .. A design cam followers (→ **fig. 18**) are based on double row, full complement cylindrical roller bearings without an integral flange between the two roller sets. The stud head and pressed-on flange ring guide the outer ring axially via the roller sets. This enables NUKR .. A design cam followers to accommodate relatively heavy axial loads that are induced when operating in an inclined or tilted position.

A sheet metal angle ring is pressed into the outer ring shoulder on both sides to form an effective labyrinth seal.

NUKR .. A design cam followers have a hexagonal recess at each end of the stud, enabling the cam follower to be held in place by a hexagonal key (Allen wrench) during mounting. In the centre of each hexagon is a relubrication hole for a press-in grease fitting or an adapter from a central lubrication system (→ *Accessories*, **page 1109**).

PWKR ...2RS design cam followers

PWKR ...2RS design cam followers (→ **fig. 19**) are based on double row, full complement cylindrical roller bearings. The stud head and a pressed-on flange ring guide the outer ring axially via the roller sets. This enables PWKR ...2RS design cam followers to accommodate relatively heavy constant axial loads that are induced when operating in an inclined or tilted position.

PWKR ...2RS design cam followers are supplied with an NBR contact seal on both sides. The seals are integral with the sheet metal angle rings and press against the flange ring and the stud head. The angle rings are pressed into the outer ring shoulder.

PWKR ...2RS design cam followers have a hexagonal recess at both ends of the stud, enabling the cam follower to be held in place by a hexagonal key (Allen wrench) during mounting. In the centre of each hexagon is a relubrication hole for a press-in grease fitting or an adapter from a central lubrication system (→ *Accessories*, **page 1109**).

Fig. 18

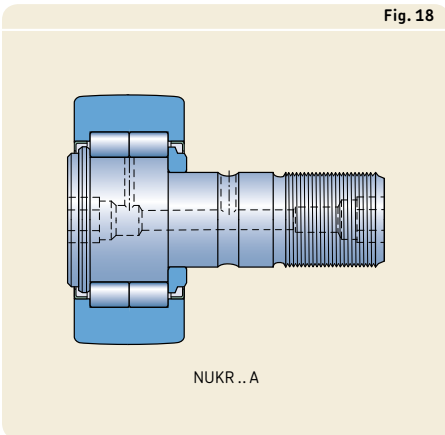
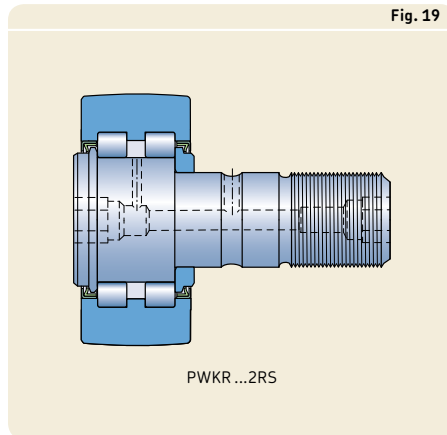

Fig. 19



14 Track runner bearings

Table 1

Accessories for cam followers

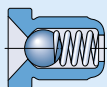

Grease fitting



Plug

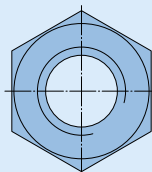

Hexagonal nut

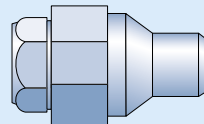

Adapter

Cam follower Design	Size without seals	with seals	Supplied with the cam follower		To be ordered separately	
			Grease fitting	Hexagonal nut	Plug	Adapter
KR						
KRE						
KRV						
	16	16 PPA	NIP A1	M 6x1	VD1	–
	–	16 PPSKA	–	M 6x1	–	–
	19	19 PPA	NIP A1	M 8x1,25	VD1	–
	–	19 PPSKA	–	M 8x1,25	–	–
	22 B	22 PPA	2 x NIP A1x4,5	M 10x1	–	–
	26 B	26 PPA	2 x NIP A1x4,5	M 10x1	–	–
	30 B	30 PPA	2 x NIP A1x4,5	M 12x1,5	–	–
	32 B	32 PPA	2 x NIP A1x4,5	M 12x1,5	–	–
	35 B	35 PPA	2 x NIP A2x7,5	M 16x1,5	–	AP 8
	40 B	40 PPA	2 x NIP A2x7,5	M 18x1,5	–	AP 8
	–	47 PPA	2 x NIP A2x7,5	M 20x1,5	–	AP 10
	–	52 PPA	2 x NIP A2x7,5	M 20x1,5	–	AP 10
	–	62 PPA	2 x NIP A3x9,5	M 24x1,5	–	AP 14
	–	72 PPA	2 x NIP A3x9,5	M 24x1,5	–	AP 14
	–	80 PPA	2 x NIP A3x9,5	M 30x1,5	–	AP 14
	–	90 PPA	2 x NIP A3x9,5	M 30x1,5	–	AP 14
NUKR .. A						
NUKRE .. A						
PWKRE ...2RS						
PWKRE ...2RS						
	–	35	2 x NIP A2x7,5	M 16x1,5	–	AP 8
	–	40	2 x NIP A2x7,5	M 18x1,5	–	AP 8
	–	47	2 x NIP A2x7,5	M 20x1,5	–	AP 10
	–	52	2 x NIP A2x7,5	M 20x1,5	–	AP 10
	–	62	2 x NIP A3x9,5	M 24x1,5	–	AP 14
	–	72	2 x NIP A3x9,5	M 24x1,5	–	AP 14
	–	80	2 x NIP A3x9,5	M 30x1,5	–	AP 14
	–	90	2 x NIP A3x9,5	M 30x1,5	–	AP 14

Table 2

Grease fittings

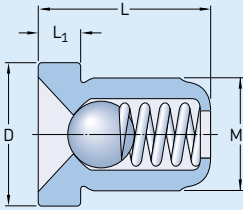

Designation	Dimensions			
	M ₁	D	L	L ₁
— mm				
NIP A1	4	6	6	1,5
NIP A1x4,5	4	4,7	4,5	1
NIP A2x7,5	6	7,5	7,5	2
NIP A3x9,5	8	10	9,5	3

Accessories

Accessories provide SKF cam followers with reliable lubrication and location (→ table 1). Accessories, other than grease fittings and hexagonal nuts must be ordered separately.

Grease fittings

SKF supplies the appropriate grease fittings, that can be pressed into position, with each cam follower as standard (→ table 1). These are the only grease fittings that should be used. Dimensions are listed in table 2.

For KR design cam followers, sizes 16 and 19, the head of the grease fitting protrudes from the head end of the stud by 1,5 mm.

Hexagonal nuts

SKF supplies the appropriate hexagonal nuts with each cam follower as standard (→ table 1). They are in accordance with ISO 4032 or ISO 8673. These 8.8 strength class nuts are zinc galvanized to ISO 4042. Dimensions and recommended tightening torques are listed in table 3.

Plugs

The end of the relubrication hole in the stud of KR design cam followers, sizes 16 and 19, except those with the designation suffix PPSKA, can be plugged if relubrication is not required or if there is no space for the head of the grease fitting. Appropriate plugs (→ table 1) with a VD1 designation must be ordered separately.

Table 3

Hexagonal nuts

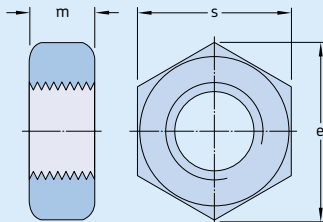

Size	Dimensions			Tightening torque	Standard ¹⁾
	m	e	s		
— mm					
Nm					
M 6x1	5,2	11	10	3	1
M 8x1,25	6,8	14,4	13	8	1
M 10x1	8,4	17,8	16	15	2
M 12x1,5	10,8	20	18	22	2
M 16x1,5	14,8	26,8	24	58	2
M 18x1,5	15,8	29,6	27	87	2
M 20x1,5	18	33	30	120	2
M 24x1,5	21,5	39,5	36	220	2
M 30x1,5	25,6	50,9	46	450	2

¹⁾ 1 = EN ISO 4032, ISO 4032
2 = EN ISO 8673, ISO 8673

14 Track runner bearings

Table 4

Dimensions of adapters for connecting to a centralized lubrication system

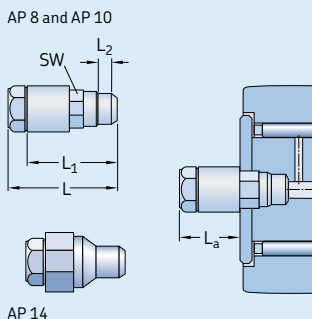

Designation	Dimensions		L ₂	L _a	SW
	L	L ₁			
–	mm				
AP 8	27	22	4	16	8
AP 10	27	22	5	15	10
AP 14	25	20	6	8	14

Adapters for connecting to a centralized lubrication system

AP design adapters enable cam followers to be relubricated via a centralized lubrication system. These adapters have a connection that accommodates, for example, 4 × 0,75 polyamide tubing in accordance with DIN 73378 (→ fig. 20). Appropriate adapters are listed in table 1 (→ page 1108), the dimensions are listed in table 4.

Fig. 20

Adapter for connection to a centralized lubrication system

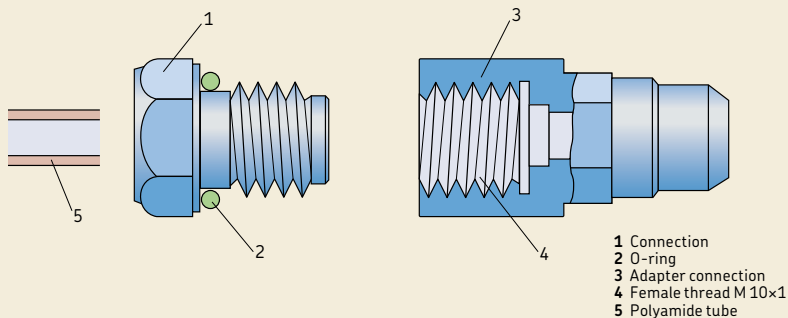





Cages

Depending on their design and series, SKF track runner bearings are fitted with one of the cages shown in **table 5**. Double row cam rollers are equipped with two cages. The standard cage is not identified in the bearing designation.

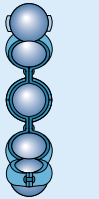
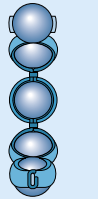
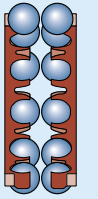
The lubricants generally used for rolling bearings do not have a detrimental effect on cage properties. However, some synthetic oils and greases with a synthetic oil base and lubricants containing a high proportion of EP additives, when used at high temperatures, can have a detrimental effect on polyamide cages. For information about the suitability of cages, refer to *Cages* (→ **page 37**) and *Cage materials* (→ **page 152**).

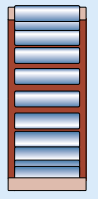
Table 5

Cages for track runner bearings						
	Single row cam rollers		Double row cam rollers	Support rollers		Cam followers
						
Cage type	Riveted, ball centred	Ribbon-type, ball centred	Snap-type, ball centred	Window-type, centring depends on size and design	Window-type, outer raceway centred	Window-type, roller centred
Material	Stamped steel	Stamped steel	PA66, glass fibre reinforced	Sheet steel	PA66, glass fibre reinforced	Sheet steel
Suffix	-	-	-	-	TN	-

14 Track runner bearings

Lubrication

SKF track runner bearings are supplied greased. They are filled with the appropriate amount of a high-quality grease under clean conditions. The technical specifications of the greases are listed in **table 6**.

(R)STO design support rollers can be oil or grease lubricated. In applications where oil is used, SKF recommends thoroughly washing the initial grease fill from the bearing prior to operation.

Relubrication requirements

Single row cam rollers are greased for the life of the bearing and cannot be relubricated.

Double row cam rollers are also greased for the life of the bearing under normal operating conditions. If subjected to moisture or solid contaminants, or if they run for long periods at temperatures above 70 °C (160 °F), they should be relubricated. When relubricating double row cam rollers, the grease should be applied slowly to avoid damaging the shields.

Support rollers and cam followers require little maintenance, but they should be relubricated regularly to achieve their full service life. SKF recommends relubrication while the initial grease fill still has its full lubricating properties. Support rollers and cam followers used in

applications where there are light loads, relatively slow speeds and clean surroundings, can operate for long periods before relubrication is required. Support rollers and cam followers that operate under contaminated and damp conditions at high speeds or at temperatures above 70 °C (160 °F) require more frequent relubrication. Full complement support rollers or cam followers require more frequent relubrication.

KR design cam followers, sizes 16 and 19, designation suffix PPSKA, cannot be relubricated.

Table 6

Technical specifications of SKF greases for track runner bearings

Bearing type	Specifications for the initial grease fill Temperature range ¹⁾						Thickener	Base oil type	NLGI consistency class	Base oil viscosity [mm ² /s]		Grease for relubrication
	-50	0	50	100	150	200				250	at 40°C (105 °F)	
Single row cam roller (D ≤ 62 mm)							Lithium soap	Mineral	2	70	7,3	-
Single row cam roller (D > 62 mm), Double row cam roller							Lithium soap	Mineral	3	100	10	- LGMT 3
Support roller, Cam follower							Lithium complex soap	Mineral	2	160	15,5	LGWA 2

¹⁾ Refer to the SKF traffic light concept → page 244

Relubrication facilities

SKF supplies all inner rings for support rollers and double row cam rollers with one lubrication hole, except for inner rings of the NNTR design support rollers, which have three lubrication holes when $d \leq 90$ mm or six lubrication holes when $d \geq 100$ mm. If suitable ducts are provided in the pin, the bearings are easy to relubricate.

Cam followers can be relubricated via ducts in the stud. Depending on series and size, there are up to three positions for relubrication (→ **fig. 21**). Detailed information about the positions can be obtained from the product tables (→ **page 1140**). Positions 1 and 2 can take the grease fitting supplied with the cam follower. Position 3 should be used when relubricating via ducts in the adjacent components. Positions not used for relubrication should be closed with a grease fitting or a plug.

For cam followers, size ≥ 35 , positions 1 and 2 can be connected to a central lubrication system (→ *Accessories*, **page 1109**).

Fig. 21

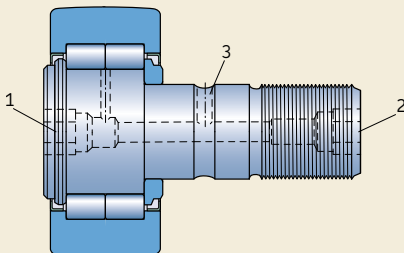

Bearing data

	Single row cam rollers	Double row cam rollers
Dimension standards	ISO 15, dimension series 02, except for the outside diameter	ISO 15, dimension series 32, except for the outside diameter
Profile of the outer ring running surface	Radius = 400 mm	3057.. C design Cylindrical (flat) 3058.. C design Radius = 400 mm
Tolerances	Normal, except: <ul style="list-style-type: none"> diameter of the crowned running surface: twice the Normal tolerance 	
For additional information (→ page 132)	Values for Normal tolerance class: ISO 492 (→ table 3, page 137). Values for ISO tolerance classes h7, h9, h10, ...	
Internal clearance	C3	Normal
For additional information (→ page 149)	Values: ISO 5753-1 (→ table 6, page 314)	Values 32 A series: (→ table 7, page 489)
	Values are valid for unmounted bearings under zero ...	
Defect frequencies	Defect frequencies can be calculated using the tools available ...	

Support rollers	Cam followers
<p>(R)NA 22 designs ISO 15, dimension series 22, except for the outer ring width</p> <p>NATR, NATV, NUTR .. A, PWTR designs ISO 7063 and ANSI/ABMA Standard 18.1 (where standardized)</p> <p>(R)STO designs Not standardized</p>	<p>ISO 7063 and ANSI/ABMA Standard 18.1 (where standardized)</p>
<p>(R)STO, (R)NA 22, NATR, NATV designs Radius = 500 mm</p> <p>NNTR design D ≤ 260 mm → Radius = 10 000 mm D ≥ 290 mm → Radius = 15 000 mm</p> <p>NATR .. PPA, NATV .. PPA, NUTR .. A, PWTR designs Improved crowned profile for better load distribution, higher stiffness and reduced wear</p>	<p>KR .. (B) design Radius = 500 mm</p> <p>Other designs Improved crowned profile for better load distribution, higher stiffness and reduced wear</p>
<p>Normal, except:</p> <ul style="list-style-type: none"> • diameter of the crowned running surface, NNTR design: h10 • diameter of the crowned running surface, other designs: 0/−0,05 mm • width B, NNTR design: 0/−0,5 mm • width B, NATR, NATV, NUTR .. A, PWTR designs: h12 • inside diameter F_w, RSTO, RNA 22 designs: F6 	<p>Normal, except:</p> <ul style="list-style-type: none"> • KR, KRE, KRV designs: ISO 7063 • diameter of the crowned running surface: 0/−0,05 mm • stud shank diameter: h7 • eccentric collar diameter: h9
<p>... h12 and F6: (→ table 7, page 1118)</p>	
<p>STO and NA 22 designs Normal</p> <p>Other designs Between C2 and Normal</p>	<p>Between C2 and Normal</p>
<p>Values: ISO 5753-1 (→ table 13, page 710)</p>	
<p>... measuring load.</p> <p>... online at skf.com/bearingcalculator.</p>	

Loads

	Single row cam rollers	Double row cam rollers	Support rollers
Dynamic loads	Compared to a typical rolling bearing, where the outer ring is fully supported in a housing, a track runner bearing has only a small contact area between its outside surface and the track. The actual contact area depends on the applied radial load and the profile of the runner surface. Deformation of the outer ring, caused by this limited contact, alters the load distribution in the bearing, which affects load carrying ability. The basic load ratings listed in the product tables take this into account. ...		
Static loads	The permissible static load for a track runner bearing is determined by the smaller of the values $F_{Or\ max}$ and C_0 (→ product tables). If requirements for smooth running are below normal, the static load may exceed C_0 , ...		
Axial loads	Cam rollers are intended for predominantly radial loads. If an axial load acts on the outer ring, as when the cam roller runs against a guide flange, it produces a tilting moment and the service life of the cam roller may be reduced as a consequence.	Support rollers with flange rings can generally accommodate axial loads that are induced when operating in an inclined or tilted position. The magnitude of permissible load depends on the internal design.	
Minimum load	$F_{rm} = 0,0167 C_0$		
For additional information (→ page 86)	The weight of the components supported by the bearing, together with external forces, generally exceed the requisite minimum load. If this ...		
Equivalent dynamic bearing load	$F_a/F_r \leq e$ → $P = F_r$	$F_a/F_r \leq 0,8$ → $P = F_r + 0,78 F_a$	$P = F_r$
For additional information (→ page 85)	$F_a/F_r > e$ → $P = 0,46 F_r + Y F_a$	$F_a/F_r > 0,8$ → $P = 0,63 F_r + 1,24 F_a$	
Equivalent static bearing load	$P_0 = 0,6 F_r + 0,5 F_a$ $P_0 < F_r \rightarrow P_0 = F_r$	$P_0 = F_r + 0,66 F_a$	$P_0 = F_r$
For additional information (→ page 88)			

Cam followers	Symbols
<p>... The ability to accommodate dynamic loads depends on the requisite life, but it is also important to consider the strength of the outer ring. Therefore, the value of the maximum permissible dynamic radial load $F_{r\max}$ (→ product tables) should not be exceeded.</p>	<p>C_0 = basic static load rating [kN] (→ product tables) e = limit for the load ratio depending on the relationship $f_0 F_a/C_0$ (→ table 8, page 1118) f_0 = calculation factor (→ product table)</p>
<p>... but should never exceed the maximum permissible static radial load $F_{0r\max}$.</p>	<p>F_a = axial load [kN] F_r = radial load [kN] F_{rm} = minimum radial load [kN] $F_{r\max}$ = maximum permissible dynamic radial load [kN] (→ product tables)</p>
<p>The flange rings enable cam followers to accommodate axial loads that are induced when operating in an inclined or tilted position. The magnitude of permissible load depends on the internal design.</p>	<p>$F_{0r\max}$ = maximum permissible static radial load [kN] (→ product tables) P = equivalent dynamic bearing load [kN] P_0 = equivalent static bearing load [kN] Y = calculation factor for the axial load, depending on the relationship $f_0 F_a/C_0$ (→ table 8, page 1118)</p>
<p>... is not the case, the bearing must be subjected to an additional radial load.</p>	
<p>$P = F_r$</p>	
<p>$P_0 = F_r$</p>	

14 Track runner bearings

Table 7

ISO tolerance classes

Nominal dimension		h7 ^(E) Deviations high low		h9 ^(E) Deviations high low		h10 ^(E) Deviations high low		h12 ^(E) Deviations high low		F6 ^(E) Deviations high low	
over	incl.	μm		μm		μm		μm		μm	
3	6	0	-12	-	-	-	-	-	-	-	-
6	10	0	-15	0	-36	-	-	-	-	+22	+13
10	18	0	-18	0	-43	-	-	0	-180	+27	+16
18	30	0	-21	0	-52	-	-	0	-210	+33	+20
30	50	-	-	0	-62	-	-	0	-250	+41	+25
50	80	-	-	-	-	-	-	-	-	+49	+30
120	180	-	-	-	-	0	-160	-	-	-	-
180	250	-	-	-	-	0	-185	-	-	-	-
250	315	-	-	-	-	0	-210	-	-	-	-

Table 8

Calculation factors for single row cam rollers

$f_0 F_a / C_0$	e	Y
0,172	0,29	1,88
0,345	0,32	1,71
0,689	0,36	1,52
1,03	0,38	1,41
1,38	0,4	1,34
2,07	0,44	1,23
3,45	0,49	1,1
5,17	0,54	1,01
6,89	0,54	1

Intermediate values can be obtained by linear interpolation.

Temperature limits

The permissible operating temperature for track runner bearings can be limited by:

- the dimensional stability of the bearing rings and rolling elements
- the cage
- the seals
- the lubricant

When temperatures outside the permissible range are expected, contact the SKF application engineering service.

Bearing rings and rolling elements

SKF track runner bearings undergo a special heat treatment. The bearings are heat stabilized up to at least:

- 120 °C (250 °F) for single row cam rollers
- 150 °C (300 °F) for double row cam rollers
- 140 °C (280 °F) for support rollers and cam followers

Cages

Steel cages can be used at the same operating temperatures as the bearing rings and rolling elements. For temperature limits of PA66 cages, refer to *Cage materials* (→ **page 152**).

Seals

The permissible operating temperature for seals depends on the material:

- NBR seals:
–40 to +100 °C (–40 to +210 °F)
Temperatures up to 120 °C (250 °F) can be tolerated for brief periods.
- PA66 sliding rings:
–30 to +100 °C (–20 to +210 °F)

Lubricants

Temperature limits for greases used in SKF track runner bearings are provided in **table 6** (→ **page 1112**). Temperature limits for other SKF greases are provided under *Lubrication* (→ **page 239**)

When using lubricants not supplied by SKF, the temperature limits should be evaluated according to the SKF traffic light concept (→ **page 244**).

Speed limits

Values for the limiting speeds are listed in the product tables. For additional information about the limiting speed, refer to *Speeds* (→ **page 117**).

Design of associated components

Pins

Cam rollers and support rollers generally operate under conditions of stationary inner ring load. For this type of load, and if easy displacement of the inner ring is required, the pin or shaft should be machined to tolerance class g6 (E).

The recommended pin tolerance class for support rollers without an inner ring is k5 (E). To exploit the full load carrying capacity of support rollers, the raceways on the pins should have the same hardness and surface finish normally found on bearing raceways. For additional information, refer to *Raceways on shafts and in housings* (→ page 210).

Attachment holes for studs

The holes in the adjacent part of machinery to accommodate the stud or eccentric collar of a cam follower should be machined to tolerance class H7 (E). If the requisite tightening torque for the hexagonal nut (→ table 3, page 1109) cannot be achieved or the cam followers are subjected to shock loads, the stud or eccentric collar should be mounted with an interference fit. The lead-in chamfer of the holes should be $\leq 0,5 \times 45^\circ$.

Support surfaces

Cam rollers

Cam rollers that must accommodate heavy axial loads should be supported over the entire inner ring side face (→ fig. 22). The support surface should be dimensioned according to diameter d_1 (→ product tables).

Support rollers

The outer ring support surfaces of support rollers without flange rings must be fine turned, free of burrs and clean. Unhardened surfaces should extend to at least half the outer ring side face (→ fig. 23) while hardened surfaces may be smaller.

Heavily loaded support rollers with flange rings should be axially supported over the entire flange ring side faces (→ fig. 24). The support surface should be dimensioned according to diameter d_1 (→ product tables).

Cam followers

The flange ring that is pressed onto the stud shank should be supported axially over its entire side face (→ fig. 25). The support surface should be dimensioned according to diameter d_1 (→ product tables). The strength of the material should be sufficiently high to accommodate the tightening torque.

Fig. 22

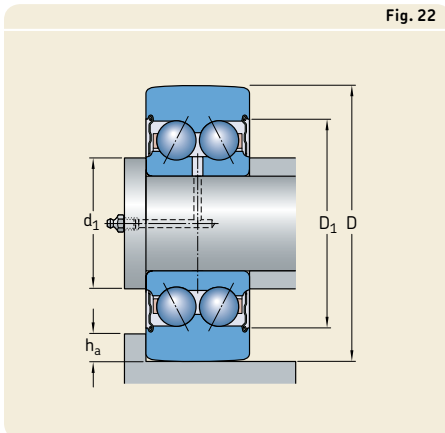
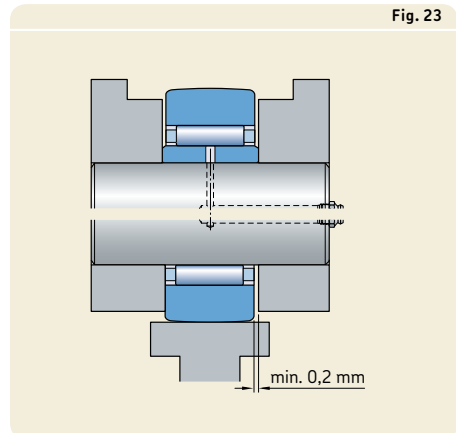

Fig. 23



Guide flanges for cam rollers

For rails or cams with guide flanges, the recommended flange height h_a (→ **fig. 22**) should be:

$$h_a \leq 0,5 (D - D_1)$$

This helps to avoid damage to the seals or shields fitted in the outer ring. The values for the outer ring diameters D and D_1 are listed in the product tables.

Axial gap

Support rollers without flange rings, but with an inner ring, and support rollers with flange rings must be located without any axial gap (→ **fig. 24**).

Support rollers without an inner ring must have an axial gap $\geq 0,2$ mm between the outer ring and support surface (→ **fig. 23**).

Fig. 24

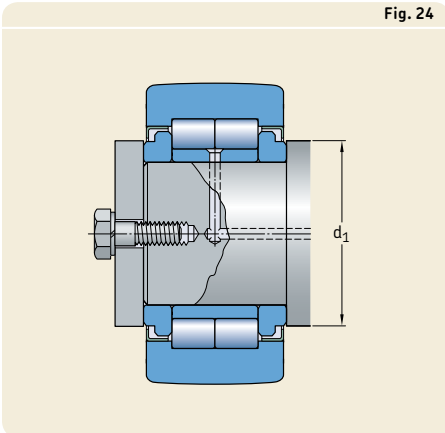
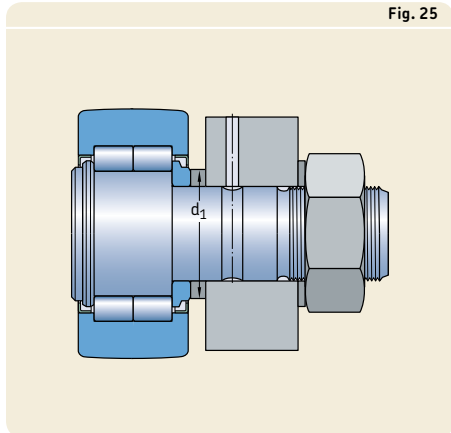

Fig. 25



Mounting

Support rollers

SKF recommends positioning the lubrication hole in the unloaded zone of the support roller inner ring, except for PWTR and NNTR design support rollers, which have the lubrication holes in the empty space between the two roller sets.

When mounting the outer ring assembly and inner ring separately, care must be taken not to damage the seal lips.

Cam followers

Cam followers can be attached to associated components (→ **fig. 25, page 1121**) using the hexagonal nut (→ **table 3, page 1109**) supplied together with the cam follower. Spring washers, which are not supplied by SKF, can be used to secure the nuts.

The nuts should be tightened to the recommended torque values listed in **table 3** (→ **page 1109**). The recommended tightening torques enable the full load carrying capacity of the cam follower to be exploited. If heavy vibrations occur, the cam followers can be located using self-locking nuts in accordance with ISO 10511 or special lock washers.

For self-locking nuts, a higher tightening torque must be applied. Follow the recommendations of the nut manufacturer.

Most cam followers (all for sizes ≥ 22) have a hexagonal recess in the stud head and can be held in place by a hexagonal key (Allen wrench) while the nut is being tightened. Some cam follower designs of the small sizes 16 and 19 have a slot in the stud head instead, and can be held in place by a screwdriver. For additional information, refer to the illustrations in the product tables (→ **page 1140**).

Depending on the mounting conditions, cam followers with an eccentric collar can be adjusted to the required eccentricity via the slot or the hexagonal recess.

Do not hit the head of the stud as damage to the cam follower may result.

SKF recommends positioning the lubrication hole in the stud head in the unloaded zone of the cam follower. The position of this hole corresponds to the marking on the head end of the stud.

The lubrication hole in position 3 (→ **fig. 21, page 1113**) may be used to incorporate a locking device to prevent the stud from turning.

When inserting a plug, it should be pressed into place using a mandrel (→ **fig. 26**).

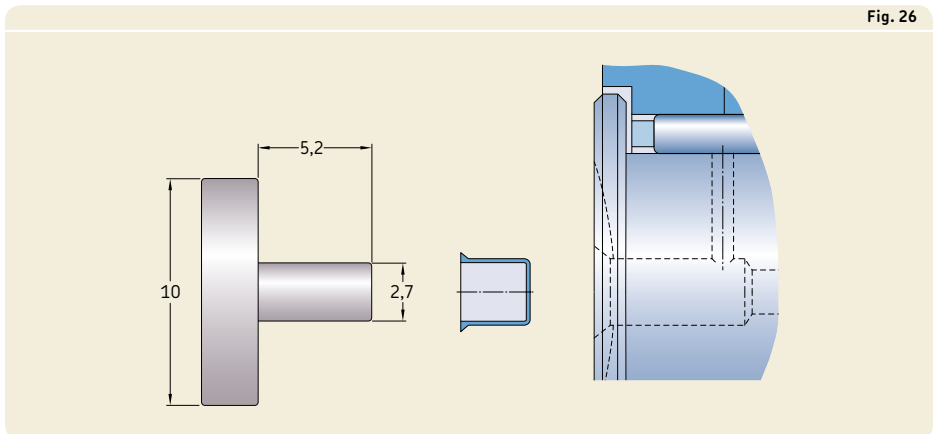

Fig. 26

Designation system

Prefixes

R Support roller without an inner ring

Basic designation

3612.. R	Single row cam roller with an NBR contact seal on both sides.
3057.. C	Double row cam roller with a cylindrical (flat) outer ring running surface.
3058.. C	Double row cam roller with a crowned outer ring running surface.
NA 22	Support roller without a flange ring, fitted with a needle roller and cage assembly.
STO	Support roller without a flange ring, fitted with a needle roller and cage assembly.
NATR	Support roller with two pressed-on flange rings, fitted with a needle roller and cage assembly.
NATV	Support roller with two pressed-on flange rings, fitted with a full complement of needle rollers.
NUTR	Support roller based on a double row, full complement cylindrical roller bearing with two integral outer ring flanges and a loose flange ring on both sides of the inner ring.
NNTR	Support roller based on a double row, full complement cylindrical roller bearing with three integral outer ring flanges and a loose flange ring on both sides of the inner ring.
PWTR	Support roller based on a double row, full complement cylindrical roller bearing with three integral outer ring flanges and a loose flange ring on both sides of the inner ring.
KR	Cam follower fitted with a needle roller and cage assembly.
KRE	Cam follower fitted with a needle roller and cage assembly, with an eccentric collar pressed onto the stud.
KRV	Cam follower fitted with a full complement of needle rollers.
KRVE	Cam follower fitted with a full complement of needle rollers, with an eccentric collar pressed onto the stud.
NUKR	Cam follower based on a double row, full complement cylindrical roller bearing with two integral outer ring flanges, with an eccentric collar pressed onto the stud.
NUKRE	Cam follower based on a double row, full complement cylindrical roller bearing with two integral outer ring flanges, with an eccentric collar pressed onto the stud.
PWKR	Cam follower based on a double row, full complement cylindrical roller bearing with three integral outer ring flanges.
PWKRE	Cam follower based on a double row, full complement cylindrical roller bearing with three integral outer ring flanges, with an eccentric collar pressed onto the stud.

Group 1	Group 2	Group 3
Group 3: Cage design		
		TN Glass fibre reinforced PA66 cage
Group 2: External design (seals, snap ring groove etc.)		
	.2RS	NBR contact seal on both sides
	.2ZL	Lamellar seal on both sides
	-2Z	Shield on both sides
	B	KR design cam follower with a hexagonal recess on both ends of the stud.
	PPA	1 NATR or NATV design support roller with a PA66 axial sliding and sealing ring on both sides. Improved crowned profile of the outer ring running surface. 2 KR design cam follower have the same features as listed above. Sizes 16 and 19 have one slot in the head of the stud as standard. Sizes ≥ 22 have a hexagonal recess on both ends.
	PPSKA	KR design cam follower, sizes 16 and 19, with a PA66 axial sliding and sealing ring on both sides, improved crowned profile of the outer ring running surface and a hexagonal recess in the head of the stud, no relubrication facilities.
	PPXA	Cam followers with PPA features except for the outer ring running surface, which has a cylindrical profile.
Group 1: Internal design		
	A	Improved crowned profile of the outer ring running surface (NUTR design support rollers or NUKR design cam followers).
	X	Cylindrical (flat) profile of the outer ring running surface.
	XA	Cylindrical (flat) profile of the outer ring running surface (NUKR .. A or NUKRE .. A design cam follower).
Suffixes		

14.1 Single row cam rollers

D 32 – 80 mm

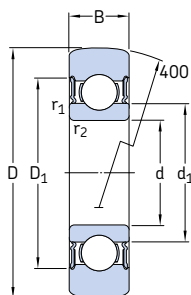

Dimensions						Limiting speed	Mass	Designation
D	B	d	d_1	D_1	$r_{1,2}$ min.			
mm						r/min	kg	-
32	9	10	17	24,8	0,6	12 000	0,04	361200 R
35	10	12	18,4	27,4	0,6	11 000	0,051	361201 R
40	11	15	21,7	30,4	0,6	9 500	0,072	361202 R
47	12	17	24,5	35	0,6	8 500	0,11	361203 R
52	14	20	28,8	40,6	1	7 000	0,15	361204 R
62	15	25	34,3	46,3	1	6 300	0,24	361205 R
72	16	30	40,3	54,1	1	5 300	0,34	361206 R
80	17	35	46,9	62,7	1,1	4 500	0,42	361207 R

Outside diameter	Basic load ratings		Fatigue load limit	Maximum radial loads		Calculation factor
	dynamic	static		dynamic	static	
D	C	C ₀	P _u	F _r	F _{0r}	f ₀
mm	kN		kN	kN		–
32	4,68	2,04	0,085	3,45	5	13
35	6,24	2,6	0,11	3,35	4,75	12
40	7,02	3,2	0,137	5,1	7,35	13
47	8,84	4,25	0,18	8,15	11,6	13
52	11,4	5,5	0,232	7,5	10,6	13
62	13	6,8	0,29	12,9	18,6	14
72	17,4	9,5	0,4	14,6	20,8	14
80	22,1	11,8	0,5	12,9	18,3	14

14.2 Double row cam rollers D 32 – 80 mm

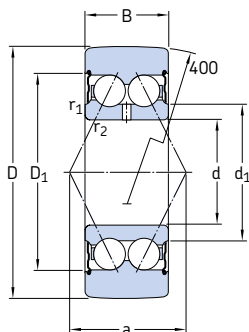

3058.. C-2Z

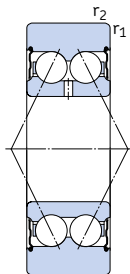

3057.. C-2Z

Dimensions							Limiting speed	Mass	Designations Cam roller with crowned runner surface	cylindrical runner surface
D	B	d	d ₁	D ₁	r _{1,2} min.	a				
mm							r/min	kg	–	
32	14	10	15,8	25	0,6	16,5	11 000	0,062	305800 C-2Z	–
35	15,9	12	17,2	27,7	0,6	19	9 500	0,078	305801 C-2Z	305701 C-2Z
40	15,9	15	20,2	30,7	0,6	21	9 000	0,1	305802 C-2Z	305702 C-2Z
47	17,5	17	23,3	35	0,6	23	8 000	0,16	305803 C-2Z	305703 C-2Z
52	20,6	20	27,7	40,9	1	28	7 000	0,22	305804 C-2Z	305704 C-2Z
62	20,6	25	32,7	45,9	1	30	6 000	0,32	305805 C-2Z	305705 C-2Z
72	23,8	30	38,7	55,2	1	36	5 000	0,49	305806 C-2Z	305706 C-2Z
80	27	35	45,4	63,9	1,1	42	4 300	0,65	305807 C-2Z	305707 C-2Z

Outside diameter	Basic load ratings		Fatigue load limit	Maximum radial loads	
	dynamic	static		dynamic	static
D	C	C ₀	P _u	F _r	F _{0r}
mm	kN		kN	kN	
32	7,61	4,3	0,183	4,4	6,3
35	10,1	5,6	0,24	3,8	5,4
40	11,2	6,8	0,285	5,85	8,5
47	14,3	8,8	0,365	9,3	13,4
52	19	12	0,51	8,3	12
62	20,8	14,3	0,6	15,3	21,6
72	28,6	20,4	0,865	17	24
80	37,7	28	1,18	15,6	22,4

14.3 Support rollers without flange rings, without an inner ring D 16 – 90 mm

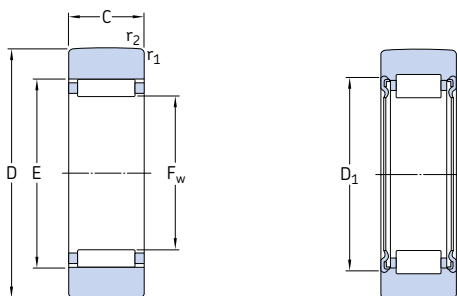

RSTO

RNA 22 ...2RS

Dimensions						Limiting speed	Mass	Designation
D	C	D ₁	F _w	E	r _{1,2} min			
mm						r/min	kg	–
16	7,8	–	7	10	0,3	8 000	0,008	RSTO 5 TN
19	9,8	–	10	13	0,3	7 000	0,012	RSTO 6 TN
	11,8	16	10	–	0,3	7 000	0,018	RNA 22/6.2RS
24	9,8	–	12	15	0,3	7 000	0,021	RSTO 8 TN
	11,8	18	12	–	0,3	6 700	0,029	RNA 22/8.2RS
30	11,8	–	14	20	0,3	6 000	0,042	RSTO 10
	13,8	20	14	–	0,6	6 300	0,052	RNA 2200.2RS
32	11,8	–	16	22	0,3	5 600	0,049	RSTO 12
	13,8	22	16	–	0,6	6 000	0,057	RNA 2201.2RS
35	11,8	–	20	26	0,3	5 000	0,05	RSTO 15
	13,8	26	20	–	0,6	5 000	0,06	RNA 2202.2RS
40	15,8	28	22	–	1	4 500	0,094	RNA 2203.2RS
	15,8	–	22	29	0,3	4 500	0,088	RSTO 17
47	15,8	–	25	32	0,3	4 000	0,13	RSTO 20
	17,8	33	25	–	1	4 000	0,15	RNA 2204.2RS
52	15,8	–	30	37	0,3	3 400	0,15	RSTO 25
	17,8	38	30	–	1	3 400	0,18	RNA 2205.2RS
62	19,8	43	35	–	1	2 800	0,28	RNA 2206.2RS
	19,8	–	38	46	0,6	2 600	0,26	RSTO 30
72	19,8	–	42	50	0,6	2 200	0,38	RSTO 35
	22,7	50	42	–	1,1	2 200	0,43	RNA 2207.2RS
80	19,8	–	50	58	1	1 900	0,42	RSTO 40
	22,7	57	48	–	1,1	1 900	0,53	RNA 2208.2RS
85	19,8	–	55	63	1	1 700	0,45	RSTO 45
90	19,8	–	60	68	1	1 600	0,48	RSTO 50

Designation	Basic load ratings		Fatigue load limit	Maximum radial loads	
	dynamic	static		dynamic	static
	C	C ₀	P _u	F _r	F _{0r}
–	kN		kN	kN	
RSTO 5 TN	2,51	2,5	0,27	3,55	5
RSTO 6 TN	3,74	4,5	0,5	4,25	6,1
RNA 22/6.2RS	4,02	3,65	0,425	2,55	3,6
RSTO 8 TN	4,13	5,4	0,6	7,5	10,8
RNA 22/8.2RS	4,68	4,55	0,54	5,3	7,5
RSTO 10	8,25	8,8	1,04	8,5	12,2
RNA 2200.2RS	6,6	7,5	0,88	12	17,3
RSTO 12	8,8	9,8	1,18	8,3	12
RNA 2201.2RS	7,04	8,5	1	11,6	16,6
RSTO 15	9,13	10,6	1,27	7,1	10
RNA 2202.2RS	7,48	9,3	1,12	9,5	13,7
RNA 2203.2RS	9,52	13,2	1,6	15,3	22
RSTO 17	14,2	17,6	2,08	12	17,3
RSTO 20	16,1	21,2	2,5	18,6	26,5
RNA 2204.2RS	16,1	18	2,16	17,6	25,5
RSTO 25	16,5	22,8	2,7	18	26
RNA 2205.2RS	16,8	20	2,4	17,3	24,5
RNA 2206.2RS	17,9	25,5	3,05	28,5	40,5
RSTO 30	22,9	34,5	4,25	23,6	33,5
RSTO 35	24,6	39	4,8	36	51
RNA 2207.2RS	22,4	35,5	4,3	38	54
RSTO 40	23,8	39	4,75	34,5	49
RNA 2208.2RS	27,5	40,5	5	35,5	51
RSTO 45	25,1	43	5,3	34,5	50
RSTO 50	26	45,5	5,7	34,5	50

14.4 Support rollers without flange rings, with an inner ring D 19 – 90 mm

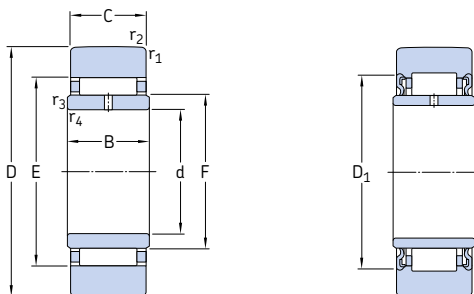

STO

NA 22 ...2RS

Dimensions										Limiting speed	Mass	Designation
D	d	C	B	D ₁	F	E	r _{1,2} min.	r _{3,4} min.				
mm										r/min	kg	-
19	6	9,8	10	-	10	13	0,3	0,3	7 000	0,017	STO 6 TN	
	6	11,8	12	16	10	-	0,3	0,3	7 000	0,022	NA 22/6.2RS	
24	8	9,8	10	-	12	15	0,3	0,3	7 000	0,026	STO 8 TN	
	8	11,8	12	18	12	-	0,3	0,3	6 700	0,034	NA 22/8.2RS	
30	10	11,8	12	-	14	20	0,3	0,3	6 000	0,049	STO 10	
	10	13,8	14	20	14	-	0,6	0,3	6 300	0,06	NA 2200.2RS	
32	12	11,8	12	-	16	22	0,3	0,3	5 600	0,057	STO 12	
	12	13,8	14	22	16	-	0,6	0,3	6 000	0,067	NA 2201.2RS	
35	15	11,8	12	-	20	26	0,3	0,3	5 000	0,063	STO 15	
	15	13,8	14	26	20	-	0,6	0,3	5 000	0,075	NA 2202.2RS	
40	17	15,8	16	28	22	-	1	0,3	4 500	0,11	NA 2203.2RS	
	17	15,8	16	-	22	29	0,3	0,3	4 500	0,11	STO 17	
47	20	15,8	16	-	25	32	0,3	0,3	4 000	0,15	STO 20	
	20	17,8	18	33	25	-	1	0,3	4 000	0,18	NA 2204.2RS	
52	25	15,8	16	-	30	37	0,3	0,3	3 400	0,18	STO 25	
	25	17,8	18	38	30	-	1	0,3	3 400	0,21	NA 2205.2RS	
62	30	19,8	20	43	35	-	1	0,3	2 800	0,32	NA 2206.2RS	
	30	19,8	20	-	38	46	0,6	0,6	2 600	0,31	STO 30	
72	35	19,8	20	-	42	50	0,6	0,6	2 200	0,44	STO 35	
	35	22,7	23	50	42	-	1,1	0,6	2 200	0,51	NA 2207.2RS	
80	40	19,8	20	-	50	58	1	1	1 900	0,53	STO 40	
	40	22,7	23	57	48	-	1,1	0,6	1 900	0,63	NA 2208.2RS	
85	45	19,8	20	-	55	63	1	1	1 700	0,58	STO 45	
90	50	19,8	20	-	60	68	1	1	1 600	0,62	STO 50	
	50	22,7	23	68	58	-	1,1	0,6	1 600	0,69	NA 2210.2RS	

Designation	Basic load ratings		Fatigue load limit	Maximum radial loads	
	dynamic	static		dynamic	static
	C	C ₀	P _u	F _r	F _{0r}
–	kN		kN	kN	
STO 6 TN	3,74	4,5	0,5	4,25	6,1
NA 22/6.2RS	4,02	3,65	0,425	2,55	3,6
STO 8 TN	4,13	5,4	0,6	7,5	10,8
NA 22/8.2RS	4,68	4,55	0,54	5,3	7,5
STO 10	8,25	8,8	1,04	8,5	12,2
NA 2200.2RS	6,6	7,5	0,88	12	17,3
STO 12	8,8	9,8	1,18	8,3	12
NA 2201.2RS	7,04	8,5	1	11,6	16,6
STO 15	9,13	10,6	1,27	7,1	10
NA 2202.2RS	7,48	9,3	1,12	9,5	13,7
NA 2203.2RS	9,52	13,2	1,6	15,3	22
STO 17	14,2	17,6	2,08	12	17,3
STO 20	16,1	21,2	2,5	18,6	26,5
NA 2204.2RS	16,1	18	2,16	17,6	25,5
STO 25	16,5	22,8	2,7	18	26
NA 2205.2RS	16,8	20	2,4	17,3	24,5
NA 2206.2RS	17,9	25,5	3,05	28,5	40,5
STO 30	22,9	34,5	4,25	23,6	33,5
STO 35	24,6	39	4,8	36	51
NA 2207.2RS	22,4	35,5	4,3	38	54
STO 40	23,8	39	4,75	34,5	49
NA 2208.2RS	27,5	40,5	5	35,5	51
STO 45	25,1	43	5,3	34,5	50
STO 50	26	45,5	5,7	34,5	50
NA 2210.2RS	28,1	43	5,3	34,5	50

14.5 Support rollers with flange rings, with an inner ring

D 16 – 42 mm

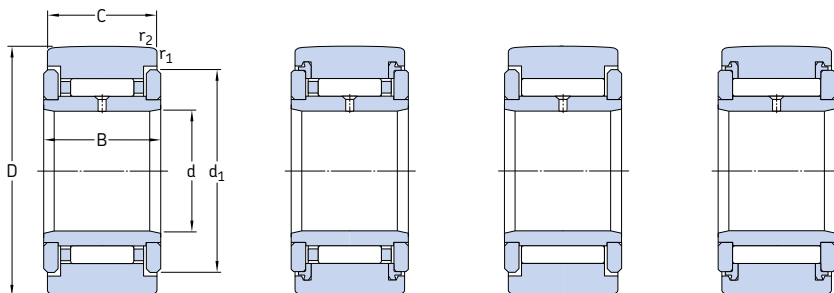

					NATR .. PPA		NATV		NATV .. PPA	
Dimensions					Limiting speed	Mass	Designation			
D	d	C	B	d ₁	r _{1,2} min.	r _{3,4} min.	r/min	kg	-	
mm										
16	5	11	12	12,5	0,15	-	6 000	0,014	NATR 5	
	5	11	12	12,5	0,15	-	6 000	0,014	NATR 5 PPA	
	5	11	12	12,5	0,15	-	4 300	0,015	NATV 5	
	5	11	12	12,5	0,15	-	4 300	0,015	NATV 5 PPA	
19	6	11	12	15	0,15	-	5 600	0,02	NATR 6	
	6	11	12	15	0,15	-	5 600	0,019	NATR 6 PPA	
	6	11	12	15	0,15	-	4 000	0,021	NATV 6	
	6	11	12	15	0,15	-	4 000	0,021	NATV 6 PPA	
24	8	14	15	19	0,3	-	5 000	0,041	NATR 8	
	8	14	15	19	0,3	-	5 000	0,038	NATR 8 PPA	
	8	14	15	19	0,3	-	3 600	0,042	NATV 8	
	8	14	15	19	0,3	-	3 600	0,041	NATV 8 PPA	
30	10	14	15	23	0,6	-	4 800	0,064	NATR 10	
	10	14	15	23	0,6	-	4 800	0,061	NATR 10 PPA	
	10	14	15	23	0,6	-	3 200	0,065	NATV 10	
	10	14	15	23	0,6	-	3 200	0,064	NATV 10 PPA	
32	12	14	15	25	0,6	-	4 500	0,071	NATR 12	
	12	14	15	25	0,6	-	4 500	0,066	NATR 12 PPA	
	12	14	15	25	0,6	-	3 000	0,072	NATV 12	
	12	14	15	25	0,6	-	3 000	0,069	NATV 12 PPA	
35	15	18	19	27,6	0,6	-	4 000	0,1	NATR 15	
	15	18	19	27,6	0,6	-	4 000	0,095	NATR 15 PPA	
	15	18	19	27,6	0,6	-	2 600	0,11	NATV 15	
	15	18	19	27,6	0,6	-	2 600	0,1	NATV 15 PPA	
	15	18	19	20	0,6	0,3	5 000	0,099	NUTR 15 A	
	15	18	19	20	0,6	0,3	5 000	0,099	PWTR 15.2RS	
40	17	20	21	31,5	1	-	3 400	0,14	NATR 17	
	17	20	21	31,5	1	-	3 400	0,14	NATR 17 PPA	
	17	20	21	31,5	1	-	2 200	0,15	NATV 17	
	17	20	21	31,5	1	-	2 200	0,15	NATV 17 PPA	
	17	20	21	22	1	0,5	4 500	0,15	NUTR 17 A	
	17	20	21	22	1	0,5	4 500	0,15	PWTR 17.2RS	
42	15	18	19	20	0,6	0,3	5 000	0,16	NUTR 1542 A	
	15	18	19	20	0,6	0,3	5 000	0,16	PWTR 1542.2RS	

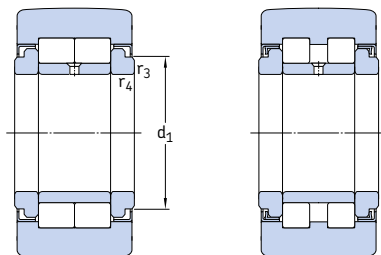

NUTR..A

PWTR...2RS

Designation	Basic load ratings		Fatigue load limit	Maximum radial loads	
	dynamic	static		dynamic	static
	C	C ₀	P _u	F _r	F _{0r}
	kN		kN	kN	
–					
NATR 5	3,14	3,2	0,345	2,9	4,15
NATR 5 PPA	3,14	3,2	0,345	2,9	4,15
NATV 5	4,73	6,55	0,72	4,05	5,7
NATV 5 PPA	4,73	6,55	0,72	4,05	5,7
NATR 6	3,47	3,8	0,415	3,8	5,5
NATR 6 PPA	3,47	3,8	0,415	3,8	5,5
NATV 6	5,28	8	0,88	5,1	7,35
NATV 6 PPA	5,28	8	0,88	5,1	7,35
NATR 8	5,28	6,1	0,695	5,2	7,35
NATR 8 PPA	5,28	6,1	0,695	5,2	7,35
NATV 8	7,48	11,4	1,32	7,35	10,4
NATV 8 PPA	7,48	11,4	1,32	7,35	10,4
NATR 10	6,44	8	0,88	7,8	11,2
NATR 10 PPA	6,44	8	0,88	7,8	11,2
NATV 10	8,97	14,6	1,66	11	15,6
NATV 10 PPA	8,97	14,6	1,66	11	15,6
NATR 12	6,6	8,5	0,95	7,65	10,8
NATR 12 PPA	6,6	8,5	0,95	7,65	10,8
NATV 12	9,35	15,3	1,76	10,6	15
NATV 12 PPA	9,35	15,3	1,76	10,6	15
NATR 15	9,52	13,7	1,56	11,4	16,3
NATR 15 PPA	9,52	13,7	1,56	11,4	16,3
NATV 15	12,3	23,2	2,7	14,6	20,8
NATV 15 PPA	12,3	23,2	2,7	14,6	20,8
NUTR 15 A	16,8	17,6	2	8,65	12,2
PWTR 15.2RS	11,9	11,4	1,2	8,65	12,5
NATR 17	10,5	14,6	1,73	12,5	18
NATR 17 PPA	10,5	14,6	1,73	12,5	18
NATV 17	14,2	26,5	3,1	17	24,5
NATV 17 PPA	14,2	26,5	3,1	17	24,5
NUTR 17 A	19	22	2,5	14	20
PWTR 17.2RS	13,8	14,3	1,5	13,7	19,6
NUTR 1542 A	20,1	23,2	2,65	21,6	31
PWTR 1542.2RS	14,2	15	1,6	22	31,5

14.5 Support rollers with flange rings, with an inner ring

D 47 – 80 mm

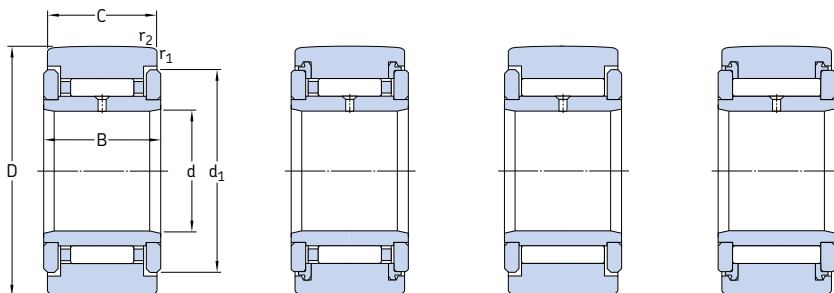

					NATR .. PPA		NATV		NATV .. PPA	
Dimensions					Limiting speed	Mass	Designation			
D	d	C	B	d ₁	r _{1,2} min.	r _{3,4} min.	r/min	kg	-	
mm										
47	17	20	21	22	1	0,5	4 500	0,22	NUTR 1747 A	
	17	20	21	22	1	0,5	4 500	0,22	PWTR 1747.2RS	
	20	24	25	36,5	1	-	3 000	0,25	NATR 20	
	20	24	25	36,5	1	-	3 000	0,24	NATR 20 PPA	
	20	24	25	36,5	1	-	1 900	0,25	NATV 20	
	20	24	25	36,5	1	-	1 900	0,25	NATV 20 PPA	
	20	24	25	27	1	0,5	3 800	0,25	NUTR 20 A	
	20	24	25	27	1	0,5	3 800	0,25	PWTR 20.2RS	
52	20	24	25	27	1	0,5	3 800	0,32	NUTR 2052 A	
	20	24	25	27	1	0,5	3 800	0,32	PWTR 2052.2RS	
	25	24	25	41,5	1	-	2 400	0,28	NATR 25	
	25	24	25	41,5	1	-	2 400	0,27	NATR 25 PPA	
	25	24	25	41,5	1	-	1 600	0,29	NATV 25	
	25	24	25	41,5	1	-	1 600	0,28	NATV 25 PPA	
	25	24	25	31	1	0,5	3 200	0,28	NUTR 25 A	
	25	24	25	31	1	0,5	3 200	0,28	PWTR 25.2RS	
62	25	24	25	31	1	0,5	3 200	0,45	NUTR 2562 A	
	25	24	25	31	1	0,5	3 200	0,45	PWTR 2562.2RS	
	30	28	29	51	1	-	1 800	0,47	NATR 30	
	30	28	29	51	1	-	1 800	0,44	NATR 30 PPA	
	30	28	29	51	1	-	1 400	0,48	NATV 30	
	30	28	29	51	1	-	1 400	0,47	NATV 30 PPA	
	30	28	29	38	1	0,5	2 600	0,47	NUTR 30 A	
	30	28	29	38	1	0,5	2 600	0,47	PWTR 30.2RS	
72	30	28	29	38	1	0,5	2 600	0,7	NUTR 3072 A	
	30	28	29	38	1	0,5	2 000	0,7	PWTR 3072.2RS	
	35	28	29	58	1,1	-	1 600	0,55	NATR 35 PPA	
	35	28	29	58	1,1	-	1 100	0,63	NATV 35 PPA	
	35	28	29	44	1,1	0,6	2 000	0,63	NUTR 35 A	
	35	28	29	44	1,1	0,6	2 000	0,63	PWTR 35.2RS	
80	35	28	29	44	1,1	0,6	2 000	0,84	NUTR 3580 A	
	35	28	29	44	1,1	0,6	2 000	0,84	PWTR 3580.2RS	

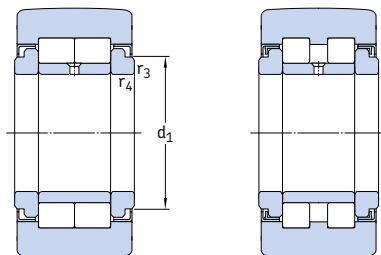

NUTR..A

PWTR...2RS

Designation	Basic load ratings		Fatigue load limit	Maximum radial loads	
	dynamic	static		dynamic	static
	C	C ₀	P _u	F _r	F _{0r}
	kN		kN	kN	
NUTR 1747 A	22	27	3,05	30	43
PWTR 1747.2RS	15,7	17,6	1,86	30	42,5
NATR 20	14,7	24,5	2,9	23,6	33,5
NATR 20 PPA	14,7	24,5	2,9	23,6	33,5
NATV 20	19,4	41,5	5	30,5	43
NATV 20 PPA	19,4	41,5	5	30,5	43
NUTR 20 A	28,6	33,5	3,9	17,6	25
PWTR 20.2RS	22,9	24,5	2,8	18,3	26
NUTR 2052 A	31,9	39	4,55	30	42,5
PWTR 2052.2RS	25,5	29	3,35	30,5	44
NATR 25	14,7	25,5	3,1	21,6	31
NATR 25 PPA	14,7	25,5	3,1	21,6	31
NATV 25	19,8	44	5,3	28,5	40,5
NATV 25 PPA	19,8	44	5,3	28,5	40,5
NUTR 25 A	29,7	36	4,25	18	25,5
PWTR 25.2RS	23,8	26,5	3,05	18,6	26,5
NUTR 2562 A	35,8	48	5,6	44	63
PWTR 2562.2RS	29,2	36	4,05	45	64
NATR 30	22,9	37,5	4,55	26,5	38
NATR 30 PPA	22,9	37,5	4,55	26,5	38
NATV 30	29,2	62	7,65	34,5	49
NATV 30 PPA	29,2	62	7,65	34,5	49
NUTR 30 A	41,3	47,5	5,85	24	34,5
PWTR 30.2RS	31,9	32,5	4,05	20,4	29
NUTR 3072 A	48,4	61	7,5	53	76,5
PWTR 3072.2RS	39,6	45	5,6	47,5	68
NATR 35 PPA	24,6	43	5,3	33,5	48
NATV 35 PPA	31,9	72	8,8	43	62
NUTR 35 A	45,7	57	6,95	33,5	47,5
PWTR 35.2RS	35,8	40,5	5	28	40
NUTR 3580 A	51,2	68	8,3	57	81,5
PWTR 3580.2RS	41,8	50	6,3	51	72

14.5 Support rollers with flange rings, with an inner ring

D 80 – 310 mm

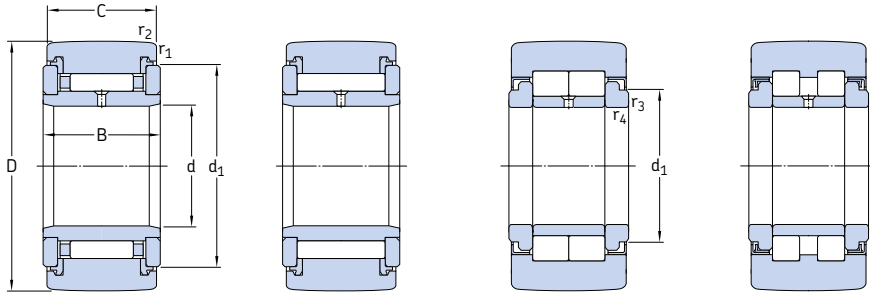

					NATR .. PPA		NATV .. PPA		NUTR .. A		PWTR ...2RS	
Dimensions					d ₁	r _{1,2} min.	r _{1, r_{3,4}} min.	Limiting speed	Mass	Designation		
D	d	C	B	Limiting speed						Mass	Designation	
mm					r/min	kg	-					
80 cont.	40	30	32	66	1,1	-	1 500	0,8	NATR 40 PPA			
	40	30	32	66	1,1	-	950	0,83	NATV 40 PPA			
	40	30	32	50,5	1,1	0,6	1 800	0,82	NUTR 40 A			
	40	30	32	50,5	1,1	0,6	1 800	0,82	PWTR 40.2RS			
85	45	30	32	55,2	1,1	0,6	1 700	0,88	NUTR 45 A			
	45	30	32	55,2	1,1	0,6	1 700	0,88	PWTR 45.2RS			
90	40	30	32	50,5	1,1	0,6	1 800	1,15	NUTR 4090 A			
	40	30	32	50,5	1,1	0,6	1 800	1,15	PWTR 4090.2RS			
	50	30	32	76	1,1	-	1 200	0,87	NATR 50 PPA			
	50	30	32	76	1,1	-	850	0,97	NATV 50 PPA			
	50	30	32	59,8	1,1	0,6	1 600	0,95	NUTR 50 A			
	50	30	32	59,8	1,1	0,6	1 600	0,95	PWTR 50.2RS			
100	45	30	32	55,2	1,1	0,6	1 700	1,4	NUTR 45100 A			
	45	30	32	55,2	1,1	0,6	1 700	1,4	PWTR 45100.2RS			
110	50	30	32	59,8	1,1	0,6	1 600	1,7	NUTR 50110 A			
	50	30	32	59,8	1,1	0,6	1 600	1,7	PWTR 50110.2RS			
130	50	63	65	63	3	2	750	5,2	NNTR 50X130X65.2ZL			
140	55	68	70	73	3	2	700	6,4	NNTR 55X140X70.2ZL			
150	60	73	75	78	3	2	670	7,8	NNTR 60X150X75.2ZL			
160	65	73	75	82	3	2	600	8,8	NNTR 65X160X75.2ZL			
180	70	83	85	92	3	2	560	13	NNTR 70X180X85.2ZL			
200	80	88	90	102	4	2	500	17	NNTR 80X200X90.2ZL			
220	90	98	100	119	4	2,5	430	22,5	NNTR 90X220X100.2ZL			
240	100	103	105	132	4	2,5	380	28	NNTR 100X240X105.2ZL			
260	110	113	115	143	4	2,5	360	35,5	NNTR 110x260x115.2ZL			
290	120	133	135	155	4	3	320	53	NNTR 120X290X135.2ZL			
310	130	144	146	165	5	3	300	65	NNTR 130x310x146.2ZL			

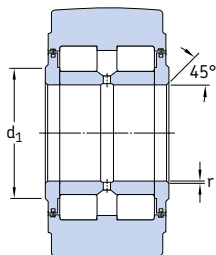

NNTR ...2ZL

Designation	Basic load ratings		Fatigue load limit	Maximum radial loads	
	dynamic	static		dynamic	static
	C	C ₀	P _u	F _r	F _{0r}
	kN		kN	kN	
-					
NATR 40 PPA	31,9	57	7,1	41,5	58,5
NATV 40 PPA	39,1	88	11	51	73,5
NUTR 40 A	57,2	72	9	32	45,5
PWTR 40.2RS	41,8	49	6	33,5	48
NUTR 45 A	58,3	75	9,3	32,5	46,5
PWTR 45.2RS	42,9	50	6,2	34	48
NUTR 4090 A	68,2	91,5	11,4	63	90
PWTR 4090.2RS	49,5	62	7,65	64	91,5
NATR 50 PPA	30,8	58,5	7,2	40	57
NATV 50 PPA	39,1	93	11,6	50	72
NUTR 50 A	58,3	78	9,65	32,5	47,5
PWTR 50.2RS	42,9	52	6,55	34,5	49
NUTR 45100 A	73,7	104	12,7	80	114
PWTR 45100.2RS	53,9	69,5	8,65	81,5	116
NUTR 50110 A	78,1	116	14,3	98	140
PWTR 50110.2RS	57,2	78	9,65	100	143
NNTR 50X130X65.2ZL	179	232	31	224	320
NNTR 55X140X70.2ZL	209	275	37,5	224	320
NNTR 60X150X75.2ZL	238	320	42,5	265	375
NNTR 65X160X75.2ZL	255	345	46,5	285	405
NNTR 70X180X85.2ZL	330	455	61	375	540
NNTR 80X200X90.2ZL	391	540	71	455	640
NNTR 90X220X100.2ZL	468	670	83	480	680
NNTR 100X240X105.2ZL	528	780	93	550	780
NNTR 110x260x115.2ZL	627	930	112	655	950
NNTR 120X290X135.2ZL	825	1 270	143	900	1 290
NNTR 130x310x146.2ZL	952	1 460	166	1 040	1 500

14.6 Cam followers

D 16 – 32 mm

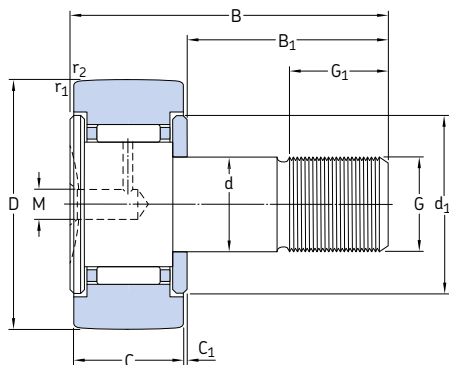

KR, sizes 16 and 19
(KR .. PPA, sizes 16 and 19
have axial sliding rings)

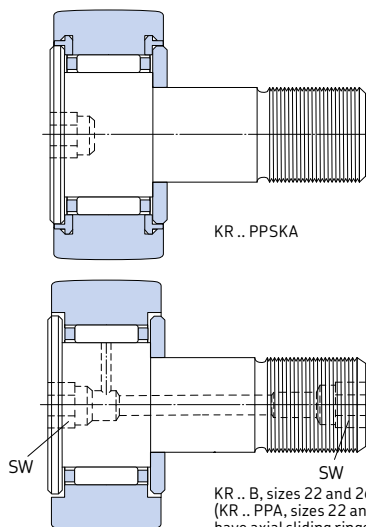

KR .. PPSKA

KR .. B, sizes 22 and 26
(KR .. PPA, sizes 22 and 26
have axial sliding rings)

Dimensions													Mass	Designation			
D	C	d	B	B ₁	B ₂	C ₁	d ₁	G	G ₁	M	M ₁	r _{1,2} min.	SW	c	B ₃		
mm															kg	-	
16	11	6	28	16	-	0,6	12,5	M6	8	4	-	0,15	-	-	-	0,019	KR 16
	11	6	28	16	-	0,6	12,5	M6	8	4	-	0,15	-	-	-	0,018	KR 16 PPA
	11	6	28	16	-	0,6	12,5	M6	8	-	-	0,15	4	-	-	0,019	KR 16 PPSKA
	11	6	28	16	-	0,6	12,5	M6	8	4	-	0,15	-	-	-	0,019	KRV 16 PPA
	11	9	28	16	-	0,6	12,5	M6	8	4	-	0,15	-	0,5	7	0,02	KRE 16 PPA
19	11	8	32	20	-	0,6	15	M6	10	4	-	0,15	-	-	-	0,029	KR 19
	11	8	32	20	-	0,6	15	M6	10	4	-	0,15	-	-	-	0,029	KR 19 PPA
	11	8	32	20	-	0,6	15	M8	10	-	-	0,15	4	-	-	0,029	KR 19 PPSKA
	11	8	32	20	-	0,6	15	M6	10	4	-	0,15	-	-	-	0,031	KRV 19 PPA
	11	11	32	20	-	0,6	15	M6	10	4	-	0,15	-	0,5	9	0,032	KRE 19 PPA
22	12	10	36	23	-	0,6	17,5	M10x1	12	4	-	0,3	5	-	-	0,045	KR 22 B
	12	10	36	23	-	0,6	17,5	M10x1	12	4	-	0,3	5	-	-	0,043	KR 22 PPA
	12	10	36	23	-	0,6	17,5	M10x1	12	4	-	0,3	5	-	-	0,045	KRV 22 PPA
	12	13	36	23	-	0,6	17,5	M10x1	12	4	-	0,3	5	0,5	10	0,047	KRE 22 PPA
26	12	10	36	23	-	0,6	17,5	M10x1	12	4	-	0,3	5	-	-	0,059	KR 26 B
	12	10	36	23	-	0,6	17,5	M10x1	12	4	-	0,3	5	-	-	0,057	KR 26 PPA
	12	10	36	23	-	0,6	17,5	M10x1	12	4	-	0,3	5	-	-	0,059	KRV 26 PPA
	12	13	36	23	-	0,6	17,5	M10x1	12	4	-	0,3	5	0,5	10	0,062	KRE 26 PPA
30	14	12	40	25	6	0,6	23	M12x1,5	13	4	3	0,6	6	-	-	0,092	KR 30 B
	14	12	40	25	6	0,6	23	M12x1,5	13	4	3	0,6	6	-	-	0,088	KR 30 PPA
	14	12	40	25	6	0,6	23	M12x1,5	13	4	3	0,6	6	-	-	0,091	KRV 30 PPA
	14	15	40	25	6	0,6	23	M12x1,5	13	4	3	0,6	6	0,5	11	0,093	KRE 30 PPA
32	14	12	40	25	6	0,6	23	M12x1,5	13	4	3	0,6	6	-	-	0,103	KR 32 B
	14	12	40	25	6	0,6	23	M12x1,5	13	4	3	0,6	6	-	-	0,098	KR 32 PPA
	14	12	40	25	6	0,6	23	M12x1,5	13	4	3	0,6	6	-	-	0,101	KRV 32 PPA
	14	15	40	25	6	0,6	23	M12x1,5	13	4	3	0,6	6	0,5	11	0,104	KRE 32 PPA

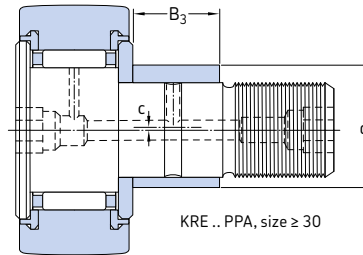
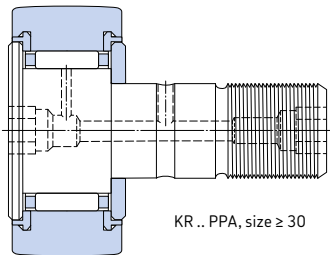
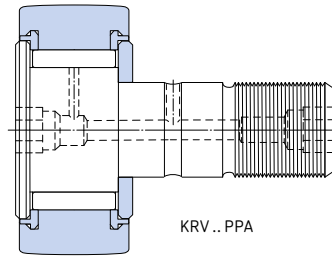
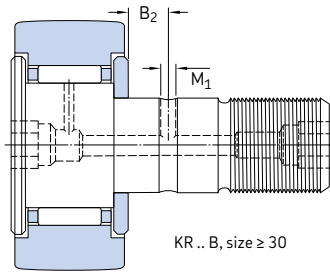

Designation	Basic load ratings		Fatigue load limit	Maximum radial loads		Limiting speed
	dynamic	static		dynamic	static	
	C	C ₀	P _u	F _r	F _{0r}	
–	kN		kN	kN		r/min
KR 16	3,14	3,2	0,345	2,9	4,15	6 000
KR 16 PPA	3,14	3,2	0,345	2,9	4,15	6 000
KR 16 PPSKA	3,14	3,2	0,345	2,9	4,15	6 000
KRV 16 PPA	4,73	6,55	0,72	4,05	5,7	4 300
KRE 16 PPA	3,14	3,2	0,345	2,9	4,15	6 000
KR 19	3,47	3,8	0,415	3,8	5,5	5 600
KR 19 PPA	3,47	3,8	0,415	3,8	5,5	5 600
KR 19 PPSKA	3,47	3,8	0,415	3,8	5,5	5 600
KRV 19 PPA	5,28	8	0,88	5,1	7,35	4 000
KRE 19 PPA	3,47	3,8	0,415	3,8	5,5	5 600
KR 22 B	4,4	5	0,56	4,25	6	5 300
KR 22 PPA	4,4	5	0,56	4,25	6	5 300
KRV 22 PPA	6,05	9,15	1,04	5,7	8,15	3 600
KRE 22 PPA	4,4	5	0,56	4,25	6	5 300
KR 26 B	4,84	6	0,655	9,3	13,2	5 300
KR 26 PPA	4,84	6	0,655	9,3	13,2	5 300
KRV 26 PPA	6,82	11	1,25	11,4	16,3	3 600
KRE 26 PPA	4,84	6	0,655	9,3	13,2	5 300
KR 30 B	6,44	8	0,88	7,8	11,2	4 800
KR 30 PPA	6,44	8	0,88	7,8	11,2	4 800
KRV 30 PPA	8,97	14,6	1,66	11	15,6	3 200
KRE 30 PPA	6,44	8	0,88	7,8	11,2	4 800
KR 32 B	6,71	8,5	0,95	10,6	15	4 800
KR 32 PPA	6,71	8,5	0,95	10,6	15	4 800
KRV 32 PPA	9,35	15,3	1,76	14,3	20,4	3 200
KRE 32 PPA	6,71	8,5	0,95	10,6	15	4 800

14.6 Cam followers

D 35 – 52 mm

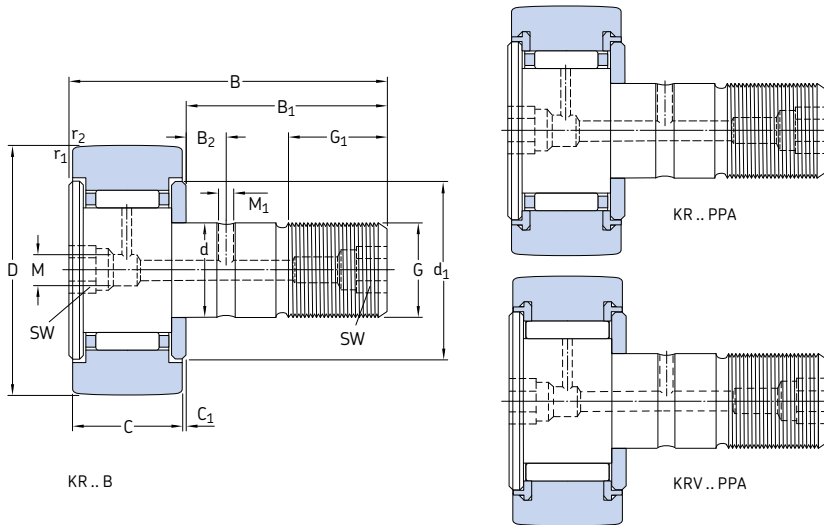

Dimensions														Mass	Designation		
D	C	d	B	B ₁	B ₂	C ₁	d ₁	G	G ₁	M	M ₁	r _{1,2} min.	SW	c	B ₃		
mm																kg	-
35	18	16	52	32,5	8	0,8	27,6	M16x1,5	17	6	3	0,6	8	-	-	0,173	KR 35 B
	18	16	52	32,5	8	0,8	27,6	M16x1,5	17	6	3	0,6	8	-	-	0,164	KR 35 PPA
	18	16	52	32,5	8	0,8	27,6	M16x1,5	17	6	3	0,6	8	-	-	0,166	KRV 35 PPA
	18	16	52	32,5	7,8	0,8	20	M16x1,5	17	6	3	0,6	8	-	-	0,164	NUKR 35 A
	18	16	52	32,5	7,8	0,8	20	M16x1,5	17	6	3	0,6	8	-	-	0,164	PWKR 35.2RS
18	20	52	32,5	8	0,8	27,6	M16x1,5	17	6	3	0,6	8	1	14	0,177	KRE 35 PPA	
	18	20	52	29,5	7,8	3,8	27,6	M16x1,5	17	6	3	0,6	8	1	12	0,177	NUKRE 35 A
	18	20	52	29,5	7,8	3,8	27,6	M16x1,5	17	6	3	0,6	8	1	12	0,177	PWKRE 35.2RS
40	20	18	58	36,5	8	0,8	31,5	M18x1,5	19	6	3	1	8	-	-	0,247	KR 40 B
	20	18	58	36,5	8	0,8	31,5	M18x1,5	19	6	3	1	8	-	-	0,239	KR 40 PPA
	20	18	58	36,5	8	0,8	31,5	M18x1,5	19	6	3	1	8	-	-	0,247	KRV 40 PPA
	20	18	58	36,5	8	0,8	22	M18x1,5	19	6	3	1	8	-	-	0,242	NUKR 40 A
	20	18	58	36,5	8	0,8	22	M18x1,5	19	6	3	1	8	-	-	0,242	PWKR 40.2RS
20	22	58	36,5	8	0,8	31,5	M18x1,5	19	6	3	1	8	1	16	0,255	KRE 40 PPA	
	20	22	58	33,5	8	3,8	30	M18x1,5	19	6	3	1	8	1	14	0,258	NUKRE 40 A
	20	22	58	33,5	8	3,8	30	M18x1,5	19	6	3	1	8	1	14	0,258	PWKRE 40.2RS
47	24	20	66	40,5	9	0,8	36,5	M20x1,5	21	6	4	1	10	-	-	0,381	KR 47 PPA
	24	20	66	40,5	9	0,8	36,5	M20x1,5	21	6	4	1	10	-	-	0,39	KRV 47 PPA
	24	20	66	40,5	9	0,8	27	M20x1,5	21	6	4	1	10	-	-	0,38	NUKR 47 A
	24	20	66	40,5	9	0,8	27	M20x1,5	21	6	4	1	10	-	-	0,38	PWKR 47.2RS
24	24	66	40,5	9	0,8	36,5	M20x1,5	21	6	4	1	10	1	18	0,4	KRE 47 PPA	
	24	24	66	40,5	9	0,8	27	M20x1,5	21	6	4	1	10	1	18	0,4	NUKRE 47 A
	24	24	66	40,5	9	0,8	27	M20x1,5	21	6	4	1	10	1	18	0,4	PWKRE 47.2RS
52	24	20	66	40,5	9	0,8	36,5	M20x1,5	21	6	4	1	10	-	-	0,454	KR 52 PPA
	24	20	66	40,5	9	0,8	36,5	M20x1,5	21	6	4	1	10	-	-	0,463	KRV 52 PPA
	24	20	66	67,5	9	0,8	31	M20x1,5	25	6	4	1	10	-	-	0,45	NUKR 52 A
	24	20	66	40,5	9	0,8	31	M20x1,5	25	6	4	1	10	-	-	0,45	PWKR 52.2RS

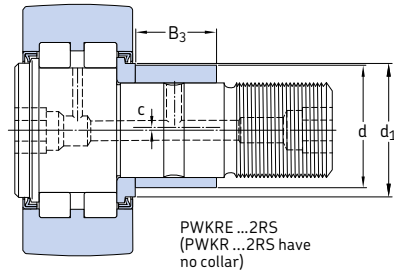
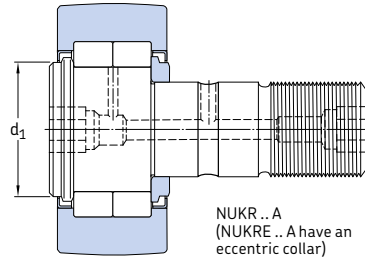
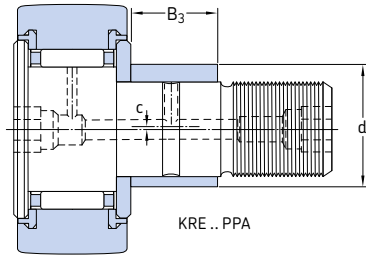

Designation	Basic load ratings		Fatigue load limit	Maximum radial loads		Limiting speed
	dynamic	static		dynamic	static	
	C	C ₀	P _u	F _r	F _{0r}	r/min
–	kN		kN	kN		
KR 35 B	9,52	13,7	1,56	11,4	16,3	4 000
KR 35 PPA	9,52	13,7	1,56	11,4	16,3	4 000
KRV 35 PPA	12,3	23,2	2,7	14,6	20,8	2 600
NUKR 35 A	16,8	17,6	2	8,65	12,2	5 000
PWKR 35.2RS	11,9	11,4	1,2	8,65	12,5	5 000
KRE 35 PPA	9,52	13,7	1,56	11,4	16,3	4 000
NUKRE 35 A	16,8	17,6	2	8,65	12,2	5 000
PWKRE 35.2RS	11,9	11,4	1,2	8,65	12,5	5 000
KR 40 B	10,5	14,6	1,73	12,5	18	3 400
KR 40 PPA	10,5	14,6	1,73	12,5	18	3 400
KRV 40 PPA	14,2	26,5	3,1	17	24,5	2 200
NUKR 40 A	19	22	2,5	14	20	4 500
PWKR 40.2RS	13,8	14,3	1,5	13,7	19,6	4 500
KRE 40 PPA	10,5	14,6	1,73	12,5	18	3 400
NUKRE 40 A	19	22	2,5	14	20	4 500
PWKRE 40.2RS	13,8	14,3	1,5	13,7	19,6	4 500
KR 47 PPA	14,7	24,5	2,9	23,6	33,5	3 000
KRV 47 PPA	19,4	41,5	5	30,5	43	1 900
NUKR 47 A	28,6	33,5	3,9	17,6	25	3 800
PWKR 47.2RS	22,9	24,5	2,8	18,3	26	3 800
KRE 47 PPA	14,7	24,5	2,9	23,6	33,5	3 000
NUKRE 47 A	28,6	33,5	3,9	17,6	25	3 800
PWKRE 47.2RS	22,9	24,5	2,8	18,3	26	3 800
KR 52 PPA	15,7	27	3,2	36	51	3 000
KRV 52 PPA	20,9	46,5	5,6	45	64	1 900
NUKR 52 A	29,7	36	4,25	18	25,5	3 200
PWKR 52.2RS	23,8	26,5	3,05	18,6	26,5	3 200

14.6 Cam followers D 52 – 80 mm

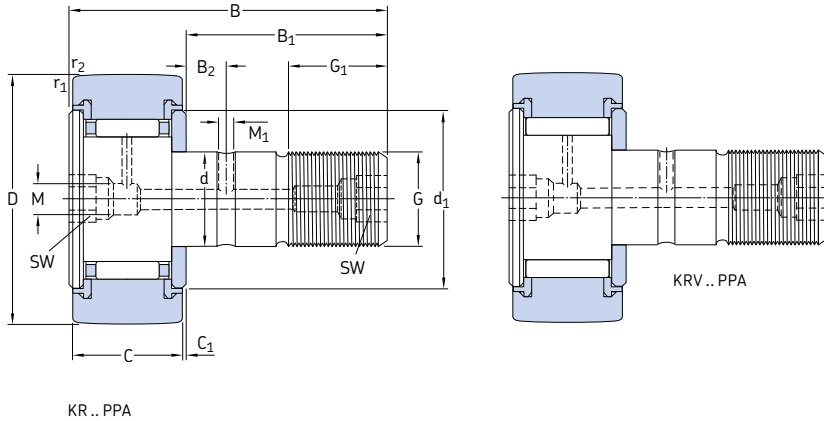

Dimensions														Mass	Designation		
D	C	d	B	B ₁	B ₂	C ₁	d ₁	G	G ₁	M	M ₁	r _{1,2} min.	SW	c	B ₃		
mm															kg	-	
52	24	24	66	40,5	9	0,8	36,5	M20x1,5	21	6	4	1	10	1	18	0,473	KRE 52 PPA
	cont. 24	24	66	40,5	9	0,8	31	M20x1,5	25	6	4	1	10	1	18	0,47	NUKRE 52 A
	24	24	66	40,5	9	0,8	31	M20x1,5	25	6	4	1	10	1	18	0,47	PWKRE 52.2RS
62	28	24	80	49,5	11	1,3	38	M24x1,5	25	8	4	1	14	-	-	0,795	NUKR 62 A
	28	24	80	49,5	11	1,3	38	M24x1,5	25	8	4	1	14	-	-	0,795	PWKR 62.2RS
	28	28	80	49,5	11	1,3	38	M24x1,5	25	8	4	1	14	1	22	0,824	NUKRE 62 A
	28	28	80	49,5	11	1,3	38	M24x1,5	25	8	4	1	14	1	22	0,824	PWKRE 62.2RS
	29	24	80	49,5	11	0,8	44	M24x1,5	25	8	4	1	14	-	-	0,77	KR 62 PPA
	29	24	80	49,5	11	0,8	44	M24x1,5	25	8	4	1	14	-	-	0,787	KRV 62 PPA
29	28	80	49,5	11	0,8	44	M24x1,5	25	8	4	1	14	1	22	0,798	KRE 62 PPA	
72	28	24	80	49,5	11	1,3	44	M24x1,5	25	8	4	1,1	14	-	-	1,02	NUKR 72 A
	28	24	80	49,5	11	1,3	44	M24x1,5	25	8	4	1,1	14	-	-	1,02	PWKR 72.2RS
	28	28	80	49,5	11	1,3	44	M24x1,5	25	8	4	1,1	14	1	22	1,05	NUKRE 72 A
	28	28	80	49,5	11	1,3	44	M24x1,5	25	8	4	1,1	14	1	22	1,05	PWKRE 72.2RS
	29	24	80	49,5	11	0,8	44	M24x1,5	25	8	4	1,1	14	-	-	1,01	KR 72 PPA
	29	24	80	49,5	11	0,8	44	M24x1,5	25	8	4	1,1	14	-	-	1,027	KRV 72 PPA
29	28	80	49,5	11	0,8	44	M24x1,5	25	8	4	1,1	14	1	22	1,038	KRE 72 PPA	
80	35	30	100	63	15	1	53	M30x1,5	32	8	4	1,1	14	-	-	1,608	KR 80 PPA
	35	30	100	63	15	1	53	M30x1,5	32	8	4	1,1	14	-	-	1,636	KRV 80 PPA
	35	30	100	63	15	1	47	M30x1,5	32	8	4	1,1	14	-	-	1,6	NUKR 80 A
	35	30	100	63	15	1	47	M30x1,5	32	8	4	1,1	14	-	-	1,6	PWKR 80.2RS
	35	35	100	63	15	1	53	M30x1,5	32	8	4	1,1	14	1,5	29	1,665	KRE 80 PPA
35	35	100	63	15	1	47	M30x1,5	32	8	4	1,1	14	1,5	29	1,67	NUKRE 80 A	
35	35	100	63	15	1	47	M30x1,5	32	8	4	1,1	14	1,5	29	1,67	PWKRE 80.2RS	

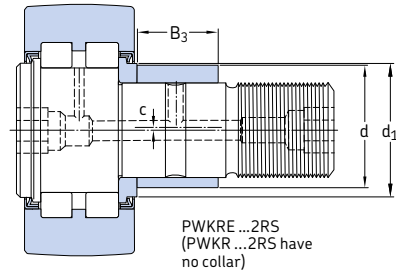
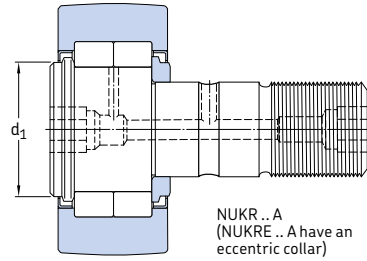
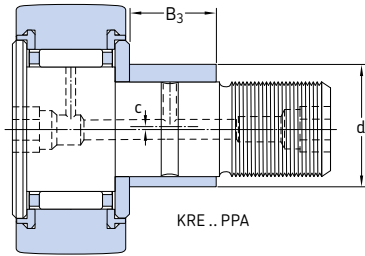

Designation	Basic load ratings		Fatigue load limit	Maximum radial loads		Limiting speed
	dynamic	static		dynamic	static	
	C	C ₀	P _u	F _r	F _{0r}	r/min
–	kN		kN	kN		
KRE 52 PPA	15,7	27	3,2	36	51	3 000
NUKRE 52 A	29,7	36	4,25	18	25,5	3 200
PWKRE 52.2RS	23,8	26,5	3,05	18,6	26,5	3 200
NUKR 62 A	41,3	48	5,85	25	36	2 600
PWKR 62.2RS	31,9	32,5	4,05	20,4	29	2 600
NUKRE 62 A	41,3	48	5,85	25	36	2 600
PWKRE 62.2RS	31,9	32,5	4,05	20,4	29	2 600
KR 62 PPA	24,6	44	5,5	58,5	85	2 400
KRV 62 PPA	31,4	72	9	72	102	1 700
KRE 62 PPA	24,6	44	5,5	58,5	85	2 400
NUKR 72 A	45,7	58,5	7,1	34,5	50	2 000
PWKR 72.2RS	39,6	45	5,6	47,5	68	2 600
NUKRE 72 A	45,7	58,5	7,1	34,5	50	2 000
PWKRE 72.2RS	39,6	45	5,6	47,5	68	2 600
KR 72 PPA	26	48	6	100	143	2 400
KRV 72 PPA	33	80	9,8	118	170	1 700
KRE 72 PPA	26	48	6	100	143	2 400
KR 80 PPA	36,9	72	9	106	150	1 800
KRV 80 PPA	45,7	114	14	122	176	1 400
NUKR 80 A	69,3	86,5	10,8	48	69,5	1 900
PWKR 80.2RS	57,2	73,5	9,3	64	91,5	2 000
KRE 80 PPA	36,9	72	9	106	150	1 800
NUKRE 80 A	69,3	86,5	10,8	48	69,5	1 900
PWKRE 80.2RS	57,2	73,5	9,3	64	91,5	2 000

14.6 Cam followers

D 90 mm

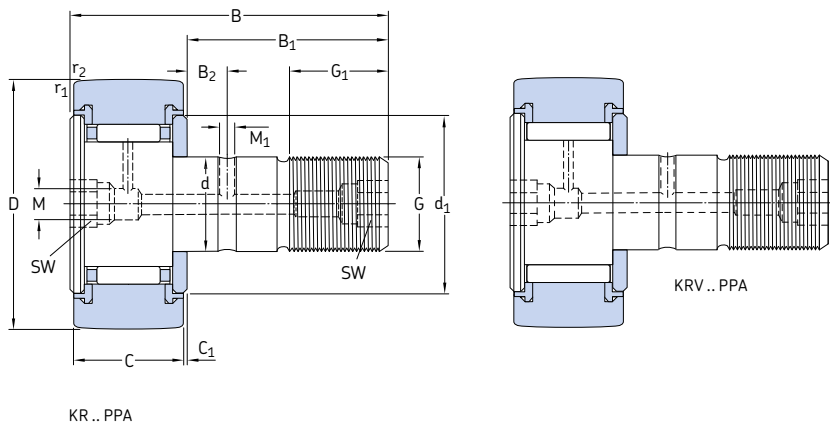

Dimensions														Mass	Designation		
D	C	d	B	B ₁	B ₂	C ₁	d ₁	G	G ₁	M	M ₁	r _{1,2} min.	SW	c	B ₃		
mm															kg	-	
90	35	30	100	63	15	1	53	M30x1,5	32	8	4	1,1	14	-	-	1,975	KR 90 PPA
	35	30	100	63	15	1	53	M30x1,5	32	8	4	1,1	14	-	-	2,003	KRV 90 PPA
	35	30	100	63	15	1	47	M30x1,5	32	8	4	1,1	14	-	-	1,96	NUKR 90 A
	35	30	100	63	15	1	47	M30x1,5	32	8	4	1,1	14	-	-	1,96	PWKR 90.2RS
	35	35	100	63	15	1	53	M30x1,5	32	8	4	1,1	14	1,5	29	2,032	KRE 90 PPA
	35	35	100	63	15	1	47	M30x1,5	32	8	4	1,1	14	1,5	29	2,02	NUKRE 90 A
	35	35	100	63	15	1	47	M30x1,5	32	8	4	1,1	14	1,5	29	2,02	PWKRE 90.2RS

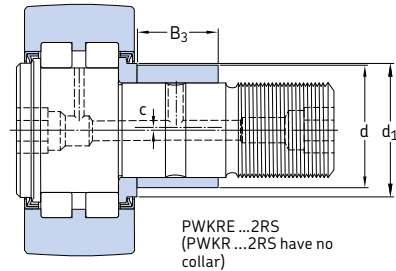
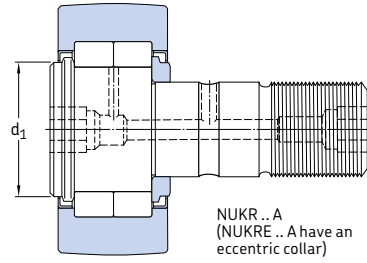
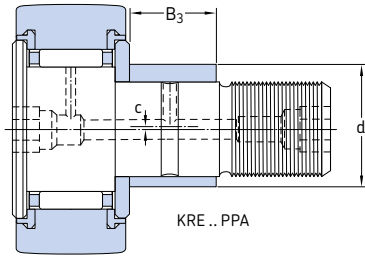

Designation	Basic load ratings		Fatigue load limit	Maximum radial loads		Limiting speed
	dynamic	static		dynamic	static	
	C	C ₀	P _u	F _r	F _{0r}	r/min
–	kN		kN	kN		
KR 90 PPA	38	76,5	9,5	160	228	1 800
KRV 90 PPA	47,3	122	15	183	260	1 400
NUKR 90 A	78,1	102	12,7	86,5	125	1 900
PWKR 90.2RS	62,7	85	10,8	108	153	2 000
KRE 90 PPA	38	76,5	9,5	160	228	1 800
NUKRE 90 A	78,1	102	12,7	86,5	125	1 900
PWKRE 90.2RS	62,7	85	10,8	108	153	2 000



15 Engineered products

15A	Sensor bearing units	1151
15B	Bearings for extreme temperatures	1169
15C	Bearings with Solid Oil	1185
15D	SKF DryLube bearings	1191
15E	INSOCOAT bearings	1205
15F	Hybrid bearings	1219
15G	NoWear coated bearings	1241
15H	Polymer ball bearings	1247





15A Sensor bearing units

Motor encoder units	1152	Other sensor bearing units	1163
Designs and variants	1152	Steering encoder units	1163
Sensor technology	1153	Designs and variants	1163
Cable connection	1154	Sensor technology and	
Grease fill	1154	electrical data	1164
Motor encoder units for extreme		Units providing absolute position	
operating conditions	1154	information	1164
Product data	1154	Sensor units for motor control of	
Requirements for the receiving		hybrid and electric vehicles	1165
interface	1154	Sensor units for angular position	
Electromagnetic compatibility	1155	sensing in off-highway vehicles	1165
High-performance filtering	1155		
Loads	1156	Product table	
Temperature limits	1156	15A.1 Motor encoder units	1166
Bearing data	1156		
Permissible speed	1157		
System design	1157		
Cable outlet	1157		
Motor encoder units in the			
non-locating bearing position	1157		
Motor encoder units in the locating			
bearing position	1158		
Motor encoder units in floating			
bearing systems	1158		
Mounting	1159		
Mounting a unit on a shaft	1159		
Mounting a unit into a housing	1160		
Cable connection	1160		
Designation system	1161		
Roller encoder units	1162		
Sensor technology	1162		

15A Sensor bearing units

Motor encoder units

Monitoring the status of rotating components accurately is essential for many applications. This is particularly true for AC motors that require encoders to continuously measure speed and the direction of rotation.

SKF motor encoder units (→ **fig. 1**) are compact and ready-to-mount units that combine active sensor technology with an SKF Explorer deep groove ball bearing. These units, which can be installed at either bearing position in an AC motor, are only 6,2 mm wider than the corresponding standard deep groove ball bearing (→ **fig. 2**). SKF motor encoder units can provide a signal resolution ranging from 32 to 80 digital pulses per revolution. They are available for shaft diameters ranging from 15 to 45 mm.

Designs and variants

SKF motor encoder units (→ **fig. 3**) are compact, integrated units consisting of:

- an SKF Explorer deep groove ball bearing in the 62 series with a snap ring groove in the outer ring (→ *Deep groove ball bearings*, **page 295**) and an RS1 contact seal
- an impulse ring
- a sensor body
- a cable outlet and connecting cable

The impulse ring, which attaches to the inner ring of the bearing, is a composite magnetized



Fig. 1

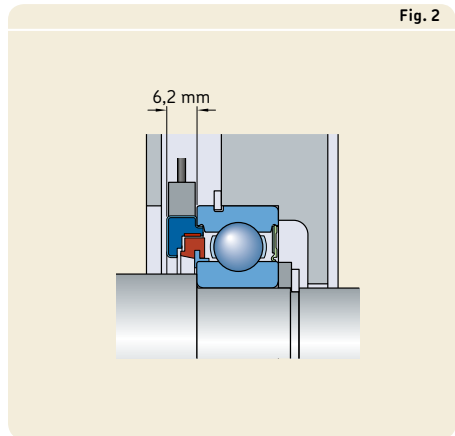

Fig. 2

More information

Bearing life and load ratings. 63

Design considerations 159

Bearing systems. 160

Recommended fits 169

Abutment and fillet dimensions. 208

Lubrication 239

Mounting, dismantling and bearing care 271

Mounting instructions for individual bearings → skf.com/mount

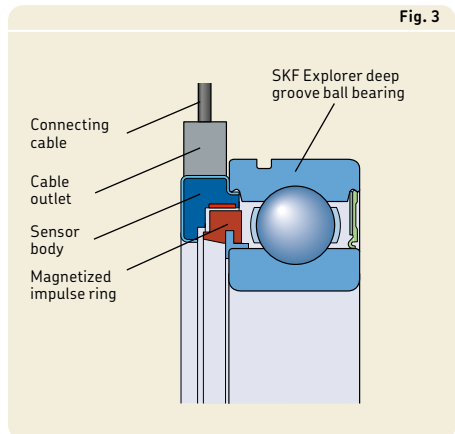

Fig. 3

ring that contains between 32 and 80 north and south poles. The number of poles depends on the size of the bearing. The sensor body, which is attached to the outer ring, protects the patented SKF Hall effect cell. The multi-wire connecting cable extends in the radial direction.

The bearing is protected by a contact seal on one side. On the opposite side of the bearing, the impulse ring and sensor body create an effective labyrinth seal to keep lubricant in and solid contaminants out of the bearing.

Sensor technology

SKF motor encoder units use a compact and robust sensor that produces an incremental encoder signal. The sensor is accurate down to zero r/min. An integrated active circuit (requiring an external voltage supply) in the sensor body contains two Hall effect cells that produce an output signal consisting of two square waves (→ fig. 4).

The signals can be interpreted by motor controllers in different ways:

- The direction of rotation can be determined from the phase shift, when the rising edge of a signal first appears.

- Slow speeds can be determined by measuring the time between two electrical events, events being the rising and falling edge on either square wave.
- High speeds can be measured by counting the number of electrical events within a given time period.

The two square waves are 90° out of phase with each other. This phase shift changes sign with the direction of rotation. **Fig. 4** shows the general specifications of the signal. The presence of two signals in quadrature enables a processing unit to multiply the number of angular position increments per revolution. For example, using a standard SKF sensor bearing with 64 pulses per revolution and a standard electronic interface that can detect the rising (Low/High) and falling (High/Low) times of each of the two signals, it is possible to obtain 256 electrical events per revolution, which translates to an angular resolution of 1,4° (→ fig. 4).

SKF motor encoder units provide accurate and reliable signals for effective motor control and are 100% tested for period accuracy, duty cycle and phase shift during manufacture.

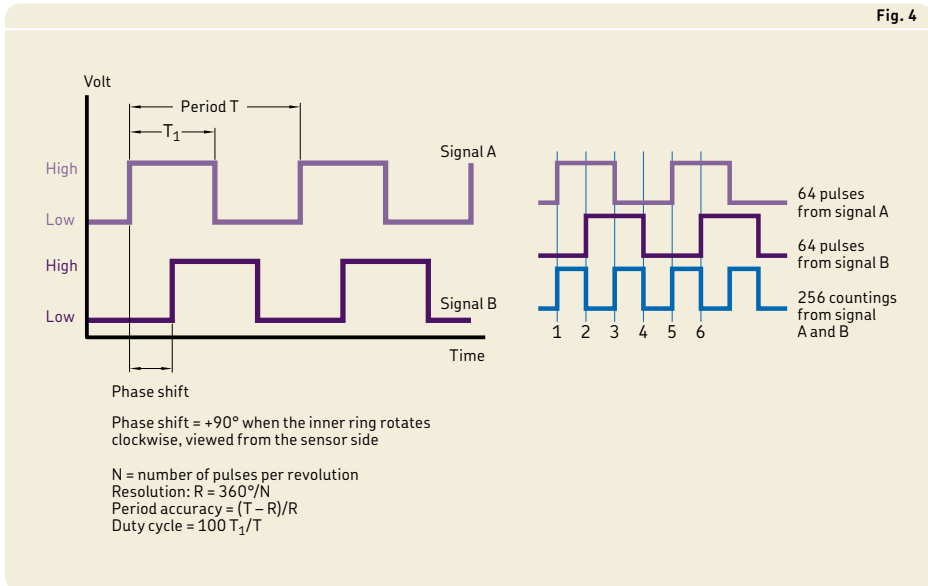

15A Sensor bearing units

Cable connection

SKF motor encoder units are available as standard with either a free cable end (designation suffix 008A, → **fig. 5**) or an AMP Superseal™ connector (AMP Nos. 282106-1 and 282404-1, designation suffix 108A, → **fig. 6**). The standard cable lengths are listed in the product table.

For alternative connectors or cable lengths, contact the SKF application engineering service.

Grease fill

SKF motor encoder units are filled with a high-quality grease under clean conditions, suitable for the most common operating conditions of electric motors. Grease specifications are listed in **table 4** (→ **page 305**), under WT grease.

Motor encoder units are considered relubrication-free. The grease life in the bearing can be calculated according to the method described under *Grease life for capped bearings* (→ **page 306**).

Motor encoder units for extreme operating conditions

Magnetic sensors have temperature and motor power limits. For applications where magnetic sensors are not practical, high-performance inductive technology can be used instead. Inductive sensors use coils to sense the rotation of a specially designed induction tooth ring.

For additional information about motor encoder units for extreme operating conditions, contact the SKF application engineering service.

Product data

Requirements for the receiving interface

The receiving interface must be able to process the signals, which are provided via open collector circuits. A typical schematic drawing is shown in **fig. 7**. Output signal features are listed in **table 1**. The phase shift is the delay between the two signals' rise events (→ **fig. 4**, **page 1153**). It is $1/4$ of the period, or 90 electric degrees. The duty cycle value is the high state of the signal compared to the full period (→ **fig. 4**, **page 1153**). It is 50% nominal.

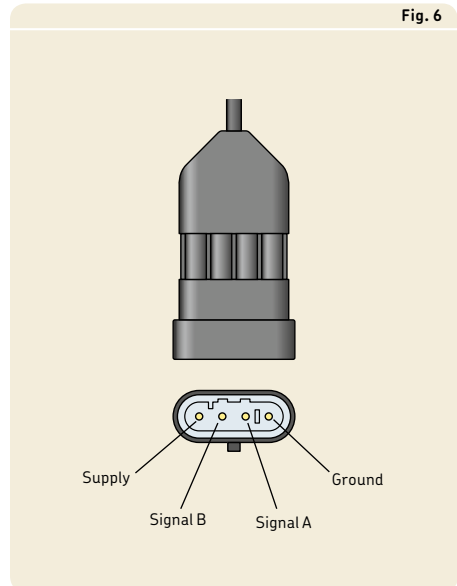
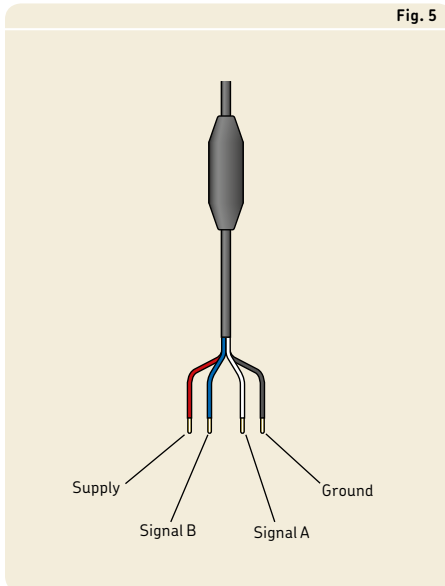

Power supply

SKF motor encoder units require a regulated voltage supply, which can range from 5 to 16 V DC. For applications above 16 volts, contact the SKF application engineering service.

Resistors

Pull-up resistors should be placed between the voltage supply and the conductors for the output signals to limit the output current to 20 mA. Recommended pull-up resistors for typical voltage supply values are listed in **table 2**.

The application load resistance between the ground line and the conductors for the output signals should be at least 10 times higher than the resistance of the pull-up resistor. This helps to keep the output signals readable.

Detecting direction of rotation

A positive phase shift corresponds to signal B rising before signal A and indicates the inner

ring rotating clockwise when viewed from the sensor side.

Electromagnetic compatibility

SKF motor encoder units can be used in systems operating in very arduous electro-magnetic environments as described in the international standard IEC 61000-6-2.

High-performance filtering

All standard SKF motor encoder units are protected with high-performance filtering, so they can adapt to the electric environment typically found in industrial and automotive applications. Motor encoder units with a free cable end have the filter included in the over-moulding on the cable. Units with an AMP Superseal™ connector have the filter integrated in the connector.

Table 1

Output signal features	
Signal type	Digital square
Number of signals	2
Phase shift	90°
Duty cycle	50% of a period

Table 2

Recommended pull-up resistors		
Voltage supply	Resistance min.	Power
V DC	Ω	W
5	270	0,25
9	470	0,25
12	680	0,25

Fig. 7

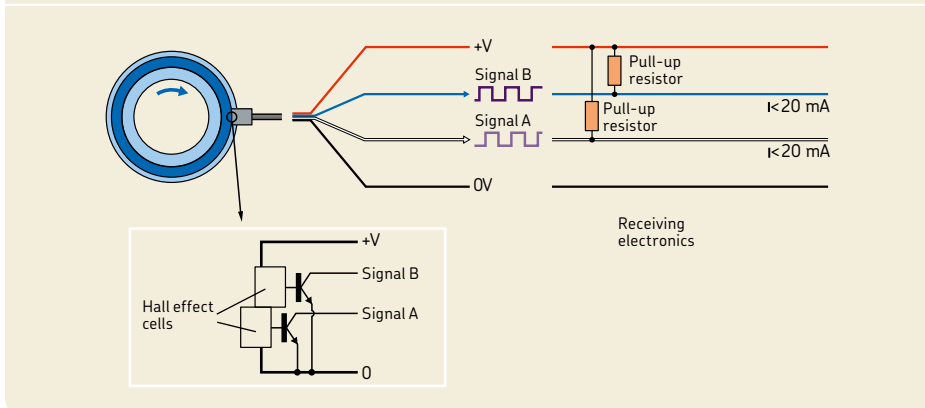

15A Sensor bearing units

Bearing data	
Dimension standards	Boundary dimensions: ISO 15 However, the width of the complete unit is 6,2 mm wider.
Tolerances	d ≤ 25 mm → P5 d ≥ 30 mm → P6
For additional information (→ page 132)	Values: ISO 492 (→ tables 4 and 5, pages 138 and 139)
Internal clearance	C3 Values: ISO 5753-1, (→ table 6, page 314) Values are valid for unmounted units under zero measuring load.
For additional information (→ page 149)	

Loads

For information about minimum load and equivalent bearing loads, refer to *Deep groove ball bearings* (→ *Loads*, page 316).

Temperature limits

SKF motor encoder units have been tested successfully under various speeds and loads:

- 500 hours at 120 °C (250 °F) with intermittent peaks of up to 10 minutes at 150 °C (300 °F)
- 100 hours at -40 °C (-40 °F)

The permissible operating temperature for SKF motor encoder units can be limited by:

- the dimensional stability of the bearing rings and balls
- the cage
- the seal
- the lubricant
- the sensor

When temperatures outside the permissible range are expected, contact the SKF application engineering service.

Bearing rings and balls

The bearing rings and balls undergo a special heat treatment. The bearings are heat stabilized up to at least 120 °C (250 °F).

Cages

Steel cages can be used at the same operating temperatures as the bearing rings and balls. For temperature limits of polymer cages, refer to *Cage materials* (→ page 152).

Seal

The permissible operating temperature for NBR seals is -40 to +100 °C (-40 to +210 °F).

Lubricant

Temperature limits for the WT grease used in SKF motor encoder units are provided under *Deep groove ball bearings* (→ table 4, page 305).

Sensor

The permissible operating temperature for the sensor is -40 to $+150$ °C (-40 to $+300$ °F).

For applications where the voltage supply is above 18 V and temperature exceeds 85 °C (185 °F), SKF recommends placing a 1 k Ω resistor in series with the supply line to limit heat generated by the electronic components.

Permissible speed

The permissible operating speed is limited by the contact seal in the bearing. The sensor can accurately detect speeds from zero r/min up to the limiting speed listed in the product table for the individual sensor unit.

System design

In principle, SKF motor encoder units can be incorporated in designs in the same way as SKF deep groove ball bearings. Some specific recommendations are described below. For additional information about electric motor applications, refer to the SKF handbook *Rolling bearings in electric motors and generators*.

Cable outlet

The cable emerges radially from the motor encoder unit. A sufficiently dimensioned cable duct must be provided in the bearing housing or housing cover. The radial notch in the housing should have a width in the circumferential direction of 15 to 20 mm (→ fig. 8).

Motor encoder units in the non-locating bearing position

SKF recommends using motor encoder units in the non-locating bearing position (→ fig. 9). However, there is a risk that the outer ring can spin in the housing bore, especially if vibration is a factor. Therefore, SKF recommends placing an O-ring in the snap ring groove to help prevent the outer ring from spinning, which could otherwise damage the cable.

Fig. 8

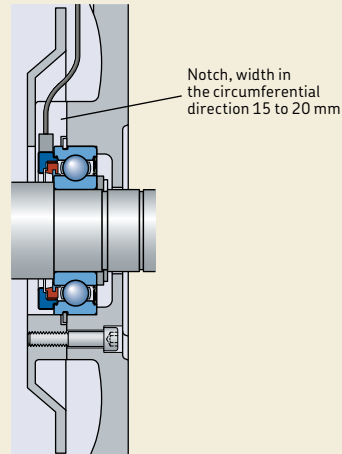
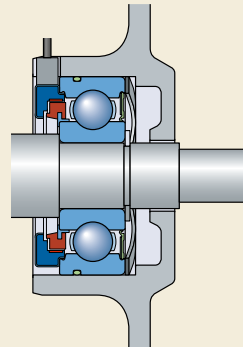

Fig. 9



15A Sensor bearing units

Motor encoder units in the locating bearing position

When using motor encoder units in the locating bearing position, the impulse ring, sensor body and connecting cable should not be subjected to any axial load, whenever possible. When the bearing is subjected to axial loads that act in both directions, the motor encoder unit should be mounted in such a way that the heavier axial load is transmitted to the bearing outer ring side face opposite the sensor (→ **fig. 10**).

Motor encoder units can be located axially in the housing in different ways:

- with a snap ring in the outer ring and a cover bolted to the housing (→ **fig. 11a**)
- with a spacer sleeve and a snap ring in the housing (→ **fig. 11b**)
- with a cover engaging the outer ring (→ **fig. 11c**)

Motor encoder units with $d \leq 25$ mm can only be located axially via a snap ring in the outer ring.

Motor encoder units in floating bearing systems

When using motor encoder units in floating bearing systems (→ **page 164**), the outer ring should be prevented from spinning by placing an O-ring in the snap ring groove. The motor encoder unit should be mounted in such a way that the axial load acts on the bearing outer ring side face opposite the sensor.

Fig. 10

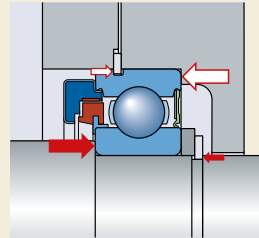

Fig. 11

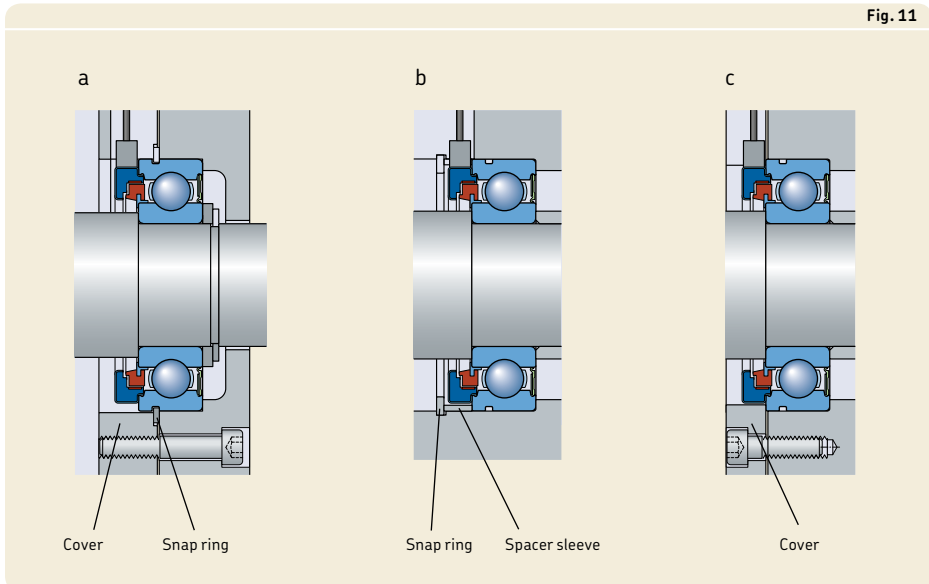
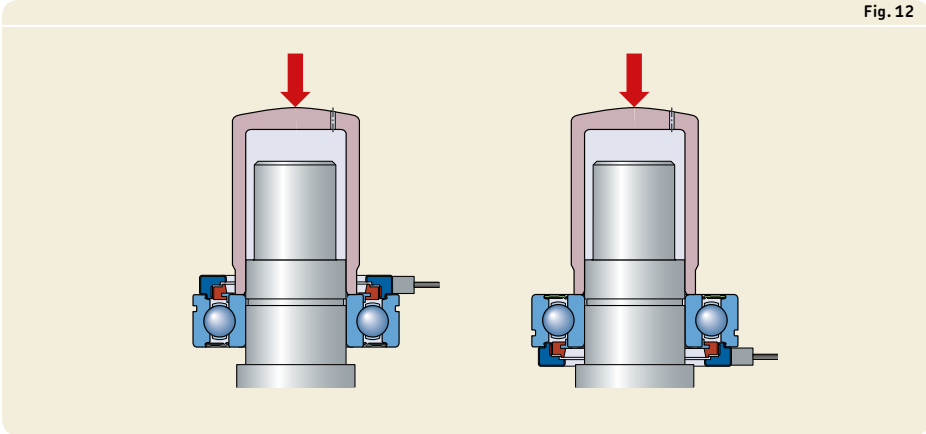

Fig. 12



Mounting

SKF motor encoder units must be handled with care to avoid damaging the bearing, sensor and connecting cable. Never apply any force on the cable, cable outlet, sensor body or impulse ring.

On request, SKF can provide assistance in optimizing the mounting and connecting processes. For additional information, contact the SKF application engineering service.

General mounting advice for SKF deep groove ball bearings is available online at skf.com/mount.

Mounting a unit on a shaft

Motor encoder units are typically mounted with an interference fit on the shaft. They can be pressed onto the shaft. The mounting force should be applied via a mounting sleeve or dolly abutting the inner ring side face (→ fig. 12).

To facilitate mounting, the bearing inner ring can be heated. Heating should only be done with a temperature-controlled electric hotplate. The bearing should be placed on a mandrel to effectively heat the inner ring (→ fig. 13). The seal should be placed in the lower position to avoid grease leaking out of the bearing. Induction heaters should not be used to heat motor encoder units as damage to the electronic components may result.

SKF does not recommend heating a motor encoder unit above 80 °C (175 °F).

Fig. 13

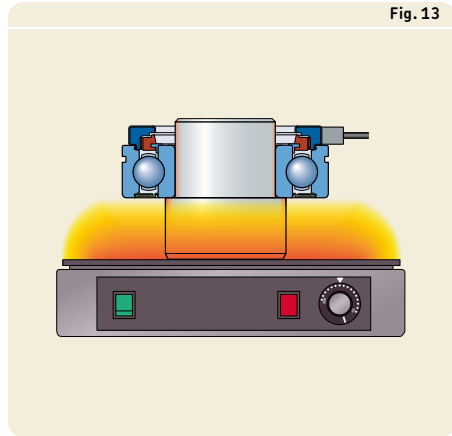

15A Sensor bearing units

Mounting a unit into a housing

When motor encoder units have to be mounted into a housing with an interference fit, they can be pressed into the housing or the housing should be heated. The mounting force should be applied via a mounting sleeve or dolly abutting the outer ring side face or a snap ring fitted on the outer ring (→ **fig. 14**).

In typical electric motor applications, the bearing can be moved into position by using bolts to pull the motor shield and cover together (→ **fig. 15**).

Cable connection

The cable should be protected by a duct to prevent it from making sharp turns, being pinched or making contact with any moving parts. To avoid any interference with the sensor signal, do not place the connector near other power cables or wires.

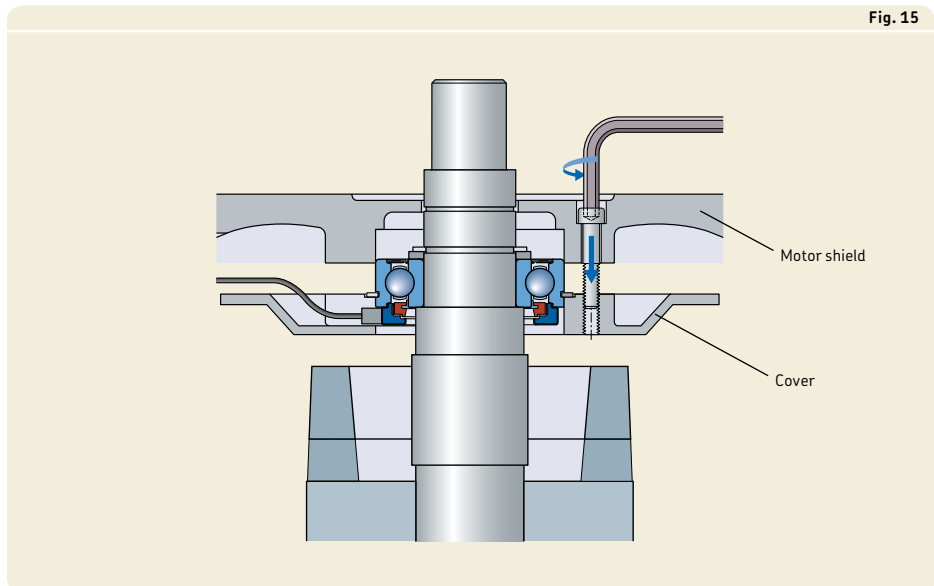
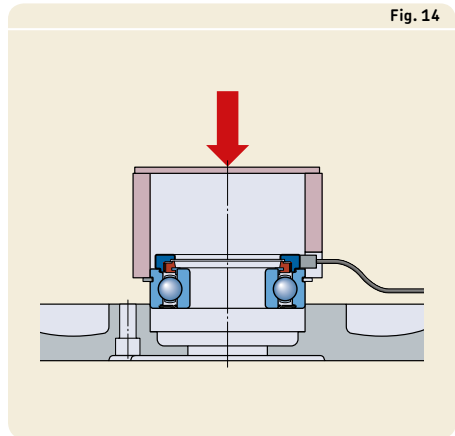

Designation system

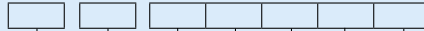

Prefixes

BMB- Motor encoder unit BMB series
BMO- Motor encoder unit BMO series

Basic designation

Listed in **diagram 2** (→ **page 43**) for deep groove ball bearings

Suffixes

/032 32 digital pulses per revolution
/048 48 digital pulses per revolution
/064 64 digital pulses per revolution
/080 80 digital pulses per revolution

S2 Two signals

/U Sales area worldwide

A Bearing with a stamped steel cage, ball centred
B Bearing with a glass fibre reinforced PA66 cage, ball centred

008A Free cable end
108A AMP Superseal™ connector (AMP Nos. 282106-1 and 282404-1)

Valid only for standard SKF motor encoder units listed in this catalogue.

Roller encoder units

SKF roller encoder units are plug-and-play sensor bearing units designed for applications with outer ring rotation. The encoder units incorporate a sealed 6201 SKF Explorer deep groove ball bearing. They can be easily integrated into pulleys, cams, rollers or wheels to provide a compact outer ring rotation encoder assembly (→ **fig. 16**). The sealed bearing is lubricated for the life of the bearing. On request, SKF can supply roller encoder units complete with customized gears, wheels or pulleys. Basic data for the SKF roller encoder unit are listed in **table 3**. For detailed specifications, contact the SKF application engineering service.

Sensor technology

SKF roller encoder units use similar sensors as SKF motor encoder units (→ **page 1152**). They provide two signals, which can be used to determine relative position, speed, acceleration and direction of movement. The requirements for the receiving interface are the same as for SKF motor encoder units (→ **page 1152**).



Fig. 16

SKF roller encoder unit

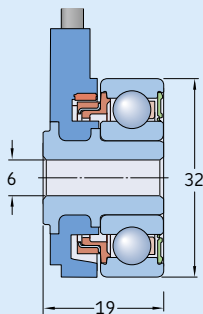

Designation	Rotational speed max. r/min	Electronic specifications			
		Pulses/rev	Period accuracy %	Duty cycle %	Phase shift °
AHE-5509 A	5 000	32	±4	50±10	90±30

Table 3

Other sensor bearing units

The SKF assortment of sensor bearing units is not limited to motor and roller encoder units. SKF has developed several solutions addressing specific applications, where sensor integration is a major added value. For additional information about these application specific sensor bearing units, contact the SKF application engineering service.

Steering encoder units

SKF steering encoder units (→ **fig. 17**) are plug-and-play steering input devices for steer-by-wire systems. They combine reliable encoder technology with the simplicity of plug-and-play component packaging.

Designs and variants

SKF steering encoder units are based on well-proven SKF technologies. They have been designed from the inside out, starting with bearing encoder technology, to precisely monitor steering. From there, a friction torque device, mechanical interface for mounting and a shaft to connect the steering wheel are added to create a complete unit. The friction torque device provides feedback to the operator by providing adequate resistance in the steering wheel.

The units contain a sealed SKF Explorer deep groove ball bearing to provide long service life and reliable performance. They do not require any adjustment or relubrication during their expected service life and are considered

maintenance-free. They reliably fulfil the demands of industrial and off-highway vehicle steer-by-wire systems.

SKF steering encoder units are supplied ready to mount. Connection to a steer-by-wire system is achieved by plugs. Available steering encoder units are listed in **table 4**. For additional information about SKF steering encoder units, contact the SKF application engineering service.



Table 4

SKF steering encoder units

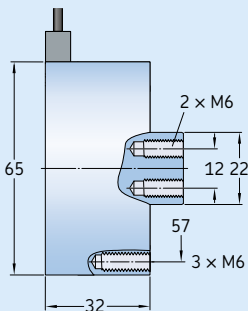

Designation	Rotational speed max. r/min	Electronic specifications			
		Pulses/rev	Period accuracy %	Duty cycle %	Phase shift °
AHE-5401 C	300	64	±4	50±10	90±30
AHE-5701 C	300	256	±20	50±10	90±50

15A Sensor bearing units

Sensor technology and electrical data

SKF steering encoder units use non-contact incremental sensors to track the movement of the steering wheel. These magnetic sensors do not wear, are protected from external influences, and are designed to provide maximum service life. SKF steering encoder units are designed to support the safety requirements of safety related control systems in accordance with ISO 13849. They contain two sets of sensors to provide redundancy.

SKF steering encoder units provide two independent sets of square wave signals (→ **fig. 18**) via open collector circuits. They require a regulated voltage supply, which can range from 5 to 12 V DC. Pull-up resistors should be placed between the voltage supply and the conductors for the output signals to limit the output current to 20 mA. Recommended pull-up resistors are listed in **table 2** (→ **page 1155**). The application load resistance between the ground line and the conductors for the output signals should be at

least 10 times higher than the resistance of the pull-up resistor. This keeps the output signals readable.

Units providing absolute position information

For applications where a combination of absolute position information, variable steering feel and active end stops are required, SKF can provide customized steering units. For additional information about available designs, contact the SKF application engineering service.

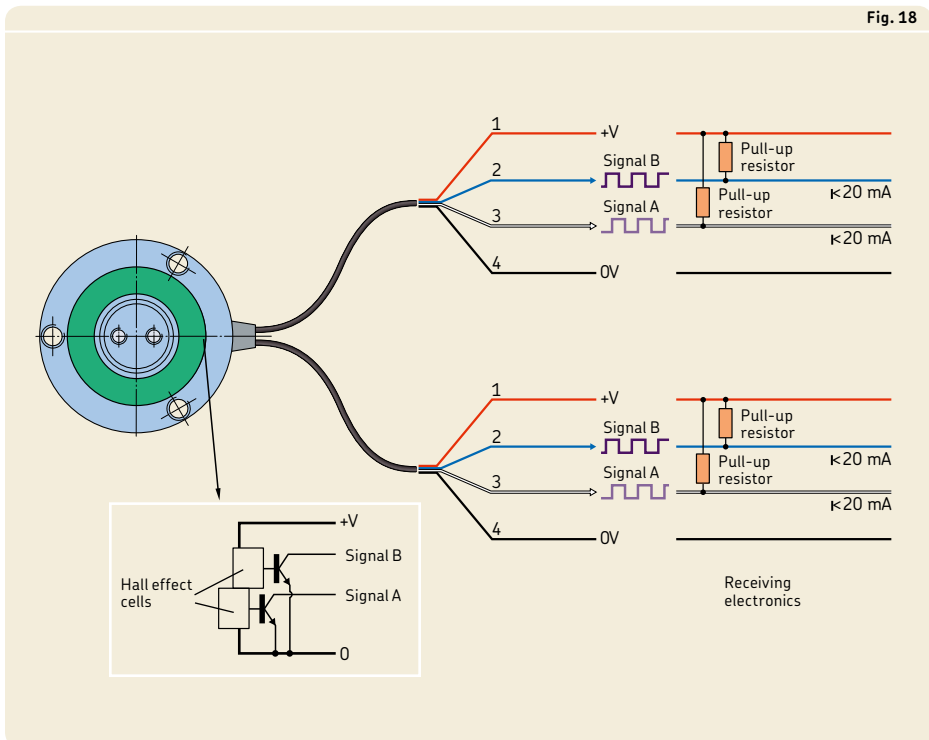

Sensor units for motor control of hybrid and electric vehicles

Brushless permanent magnet synchronous motors require a sensor that provides the position of the rotor with a high degree of accuracy to enable accurate motor torque control and to achieve maximum efficiency and dynamics. These permanent magnet motors use either direct drive control or sine wave control. SKF sensor units can contribute to optimized motor efficiency for both systems.

Units for direct drive control

For direct drive control, SKF supplies commutation units delivering three signals, each with a 120° phase shift. The number of pulses per revolution matches the number of rotor pole pairs. These units comply with the speed and temperature requirements typical for power steering applications, high-speed spindles and small brushless electric drives.

Units for sine wave control

For sine wave control, SKF supplies sensor bearing units providing the shaft angle position in real time within the entire motor speed range. These integrated units provide a signal comparable to the one provided by a resolver and can therefore be used by the motor controller's software. The shaft angle position is communicated via a sinus/cosinus signal.

SKF can adapt the electronics to comply with the interface of the application. The units can provide either an analogue or a digital encoder-like output signal. The units are more compact and cost-effective than inductive resolvers. They are easy to mount and do not require special shaft or housing accuracy.

Sensor units for angular position sensing in off-highway vehicles

Articulated joints, steer-by-wire systems or GPS tracking systems in off-highway vehicles require absolute position sensors to measure the angle between two elements. SKF can supply units providing a high-resolution absolute position signal, even under arduous environmental conditions.

Absolute position sensor solutions are tailored to customer requirements. SKF can propose a modular mechanical and electronic interface to the application to deliver a compact plug-and-play unit, not requiring intrusive modifications to the existing mechanical, electric or electronic architecture.

15A.1 Motor encoder units d 15 – 45 mm

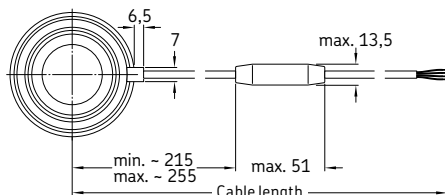
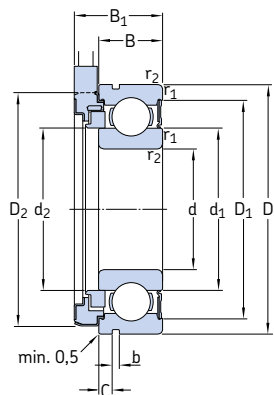

008A (free cable end)

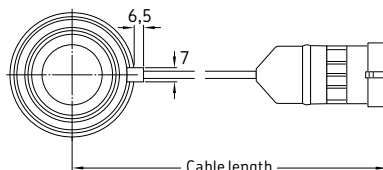

108A (AMP Superseal™)

Bearing Principal dimensions	Basic load ratings		Fatigue load limit P_u	Limiting speed	Sensor unit			Cable length ± 10	Mass	Designation		
	dynamic C	static C_0			No. of pulses	Period accur- acy	Phase shift					
mm	kN		kN	r/min	-	%	°	mm	kg	-		
15	35	11	7,8	3,75	0,16	14 000	32	± 3	90 ± 30	525	0,07	BMB-6202/032S2/UB008A
	35	11	7,8	3,75	0,16	14 000	32	± 3	90 ± 30	550	0,08	BMB-6202/032S2/UB108A
20	47	14	12,7	6,55	0,28	10 000	48	± 4	90 ± 20	535	0,13	BMO-6204/048S2/UA008A
	47	14	12,7	6,55	0,28	10 000	48	± 4	90 ± 20	560	0,15	BMO-6204/048S2/UA108A
25	52	15	14	7,8	0,335	8 500	48	± 3	90 ± 30	535	0,16	BMO-6205/048S2/UA008A
	52	15	14	7,8	0,335	8 500	48	± 3	90 ± 30	560	0,17	BMO-6205/048S2/UA108A
30	62	16	19,5	11,2	0,475	7 500	64	± 4	90 ± 20	540	0,24	BMO-6206/064S2/UA008A
	62	16	19,5	11,2	0,475	7 500	64	± 4	90 ± 20	565	0,25	BMO-6206/064S2/UA108A
40	80	18	30,7	19	0,8	5 600	80	± 5	90 ± 30	546	0,46	BMB-6208/080S2/UB008A
	80	18	30,7	19	0,8	5 600	80	± 5	90 ± 30	570	0,46	BMB-6208/080S2/UB108A
45	85	19	33,2	21,6	0,915	5 600	80	± 5	90 ± 30	545	0,53	BMB-6209/080S2/UB008A
	85	19	33,2	21,6	0,915	5 600	80	± 5	90 ± 30	570	0,54	BMB-6209/080S2/UB108A

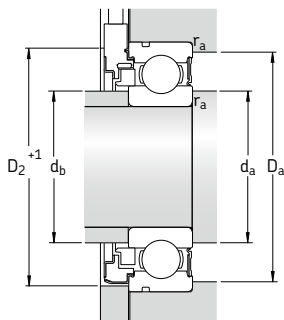

Bore diameter
of end cover
 $\geq D_2 + 1$ mm

Dimensions										Abutment and fillet dimensions				Calculation factors	
d	d_1	d_2	D_1	D_2	B_1	b	C	$r_{1,2}$ min.	d_a, d_b min.	d_b max.	D_a max.	r_a max.	k_r	f_0	
mm										mm				-	
15	21,7	19,5	30,4	34,5	17,2	1,35	2,06	0,6	19	19,4	31	0,6	0,025	13	
	21,7	19,5	30,4	34,5	17,2	1,35	2,06	0,6	19	19,4	31	0,6	0,025	13	
20	28,8	28,69	40,6	46,5	20,2	1,35	2,46	1	25	28,6	42	1	0,025	13	
	28,8	28,69	40,6	46,5	20,2	1,35	2,46	1	25	28,6	42	1	0,025	13	
25	34,4	31,6	46,3	51,5	21,2	1,35	2,46	1	30	31,3	47	1	0,025	14	
	34,4	31,6	46,3	51,5	21,2	1,35	2,46	1	30	31,3	47	1	0,025	14	
30	40,4	40,25	54,1	58	22,2	1,9	3,28	1	35	40	57	1	0,025	14	
	40,4	40,25	54,1	58	22,2	1,9	3,28	1	35	40	57	1	0,025	14	
40	52,6	47,9	69,8	75,1	24,2	1,9	3,28	1,1	46,5	47,4	73,5	1	0,025	14	
	52,6	47,9	69,8	75,1	24,2	1,9	3,28	1,1	46,5	47,4	73,5	1	0,025	14	
45	57,6	52,9	75,2	78,9	25,2	1,9	3,28	1,1	51,5	52,4	78,5	1	0,025	14	
	57,6	52,9	75,2	78,9	25,2	1,9	3,28	1,1	51,5	52,4	78,5	1	0,025	14	



15B Bearings for extreme temperatures

Extreme temperature variants.	1170
Deep groove ball bearings for extreme temperatures.	1171
Y-bearings for extreme temperatures	1172
Bearing data (Dimension standards, tolerances, internal clearance, misalignment)	1173
Selecting bearing size	1174
Design of associated components . . .	1175
Maintenance	1176
Designation system	1176

Product tables

15B.1 Single row deep groove ball bearings for extreme temperatures	1178
15B.2 Y-bearings for extreme temperatures, metric shafts . . .	1182
15B.3 Y-bearings for extreme temperatures, inch shafts	1183

Other products for extreme temperatures

SKF DryLube bearings	1191
Y-bearing units → SKF catalogue	
<i>Y-bearings and Y-bearing units</i>	

15B Bearings for extreme temperatures

Extreme temperature rolling bearings are designed to reduce machine operating costs, extend maintenance intervals and provide a high degree of operational reliability within a wide range of temperatures. The SKF assortment of extreme temperature bearings and bearing units includes:

- deep groove ball bearings (→ **fig. 1**)
- Y-bearings (insert bearings, → **fig. 2**)
- Y-bearing units (→ SKF catalogue *Y-bearings and Y bearing units*)
- SKF DryLube bearings (→ **page 1191**)

Bearings for extreme temperatures listed in this catalogue constitute the basic SKF assortment. On request, SKF can supply other extreme temperature bearings to meet the needs of a particular application. For information about these engineered products, contact the SKF application engineering service.

Extreme temperature variants

Every extreme temperature application has its own unique challenges. As a fact, SKF has developed a number of variants that help to provide excellent performance based on the operating conditions of the application. The typical variants are listed in **table 1**. For additional information, contact the SKF application engineering service.



More information

Design considerations	159
Bearing systems	160
Recommended fits	169
Abutment and fillet dimensions	208

Mounting, dismantling and bearing care	271
Mounting instructions for individual bearings	→ skf.com/mount

Deep groove ball bearings for extreme temperatures

SKF deep groove ball bearings for extreme temperatures correspond in design to standard single row deep groove ball bearings of the same size. They have no filling slots and can accommodate normal axial loads in addition to radial loads. The radial internal clearance is a multiple of C5 to prevent the bearings from seizing, even when they cool rapidly. All surfaces of the bearing and shields are manganese phosphated to enhance adhesion of the lubricant to the metal and provide additional protection against corrosion.

SKF deep groove ball bearings for extreme temperatures are available in the variants listed in **table 1**. Typically, the bearings have a shield on both sides (designation suffix 2Z). The VA201 variant is also available as an open bearing (→ **fig. 3, page 1172**).

Shields prevent the ingress of solid contaminants into the bearing. The shields on a 2Z/VA201 bearing enable the bearing to be filled with twice the amount of polyalkylene glycol/graphite lubricant found in an open VA201 bearing.

Table 1

Extreme temperature variants for deep groove ball bearings and Y-bearings

	VA201	VA208	VA228
Characteristics	<ul style="list-style-type: none"> Bearing with a riveted stamped steel cage Filled with a polyalkylene glycol/graphite mixture for lubrication Running-in period required to distribute the lubricant within the bearing for applications that stand idle for an extended period Not for wet or humid environments 	<ul style="list-style-type: none"> Bearing with a segmented cage made of graphite Dry lubricant: minute amounts of graphite powder released from the cage lubricate the bearing. A shield on both sides of the bearing guides the cage segments. Even at the upper temperature limits, the segmented graphite cage does not release harmful vapours. Should not be used for applications where the direction of rotation changes frequently. 	<ul style="list-style-type: none"> Bearing with a coronet cage made of graphite Dry lubricant: minute amounts of graphite powder released from the cage lubricate the bearing. A shield on both sides of the bearing guides the cage. Even at the upper temperature limits, the graphite cage does not release harmful vapours.
Temperature limits¹⁾	-30 to +250 °C (-20 to +480 °F)	-150 to +350 °C (-240 to +660 °F)	-150 to +350 °C (-240 to +660 °F)
Limiting speed²⁾ [r/min]	$\frac{9\,000}{d_m}$	$\frac{4\,500}{d_m}$	$\frac{9\,000}{d_m}$

d_m = bearing mean diameter [mm]
= 0,5 (d + D)

¹⁾ VA201 bearings operating below 200 °C (390 °F) at speeds below 25% of limiting speed require a running-in procedure. These bearings should be heated to 200 °C (390 °F) for at least 48 hours.

²⁾ When higher speeds are expected, consider using SKF DryLube bearings (→ **page 1191**) or contact the SKF application engineering service.

15B Bearings for extreme temperatures

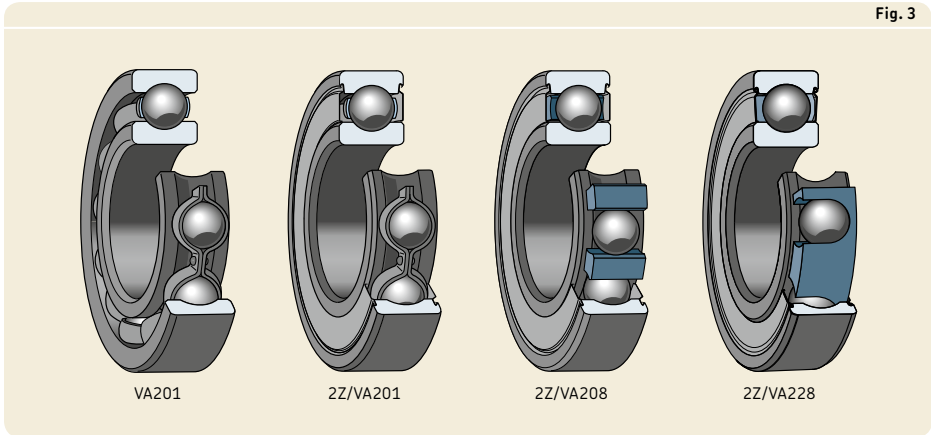

Y-bearings for extreme temperatures

Except for the cage and seals, SKF Y-bearings (insert bearings) for extreme temperatures correspond in design to standard Y-bearings with grub screws in the YAR 2-2F series. The bearings have a shield and a flinger on both sides to prevent the ingress of solid contaminants into the bearing. The radial internal clearance is twice the C5 clearance of same-sized deep groove ball bearings. All surfaces of the bearing and the shields and flingers are manganese phosphated to enhance adhesion of the lubricant to the metal and provide additional protection against corrosion.

SKF Y-bearings for extreme temperatures are available in the VA201 and VA228 variants (→ fig. 4).

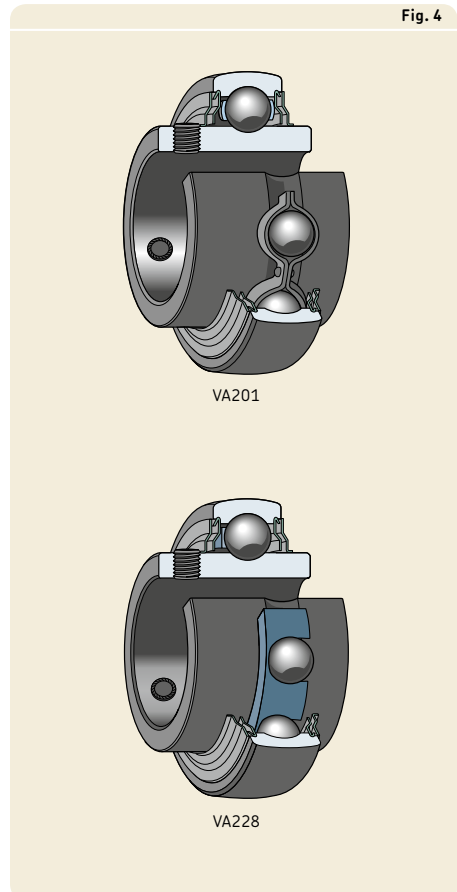

Bearing data

	Deep groove ball bearings for extreme temperatures	Y-bearings for extreme temperatures
Dimension standards	Boundary dimensions: ISO 15	Boundary dimensions: ISO 9628
Tolerances	Normal Values: ISO 492 (→ table 3, page 137)	Normal, except the bore and outside diameter Values: ISO 492 (→ table 3, page 137) Values for the bore and outside diameter (→ table 2, page 1174)
For additional information (→ page 132)	Due to the special surface treatment of the bearings, there may be slight deviations from the standard tolerances. These deviations do not effect mounting or bearing operation.	
Internal clearance	Multiples of C5	Twice C5 of deep groove ball bearings in accordance with ISO 5753-1
For additional information (→ page 149)	Values (→ table 3, page 1174) are valid for unmounted bearings under zero measuring load.	
Misalignment	≈ 20 to 30 minutes of arc	
	The above values apply only when the bearings rotate slowly. The permissible angular misalignment between the inner and outer ring depends on the size and internal design of the bearing, radial internal clearance in operation and the forces and moments acting on the bearing. As a result, only approximate values are listed here. Any misalignment increases bearing noise and reduces bearing service life.	

15B Bearings for extreme temperatures

Table 2

Tolerances of Y-bearings for extreme temperatures

Nominal diameter d, D over	incl.	Bore diameter ¹⁾ Deviation		Outside diameter Deviation	
		high	low	high	low
mm		µm		µm	
18	30	+18	0	–	–
30	50	+21	0	0	–10
50	80	+24	0	0	–10
80	120	+28	0	0	–15

¹⁾ Values in accordance with ISO 9628

Table 3

Radial internal clearance of bearings for extreme temperatures

Bore diameter d over	incl.	Radial internal clearance			
		Deep groove ball bearings		Y-bearings	
		min.	max.	min.	max.
mm		µm			
	10	40	136	–	–
10	18	50	160	–	–
18	24	56	172	56	96
24	30	60	192	60	106
30	40	80	236	80	128
40	50	90	272	90	146
50	65	110	340	110	180
65	80	130	400	–	–
80	120	150	460	–	–

Selecting bearing size

As bearings for extreme temperatures typically rotate at slow speeds, the requisite bearing size can be determined based on the basic static load rating C_0 (→ **product tables**). The bearing selected should have a C_0 value \geq the requisite value.

Calculating the requisite basic static load rating

$$C_{0\text{req}} = 2 \frac{P_0}{f_T}$$

$$P_0 = 0,6 F_r + 0,5 F_a$$

$$P_0 < F_r \rightarrow P_0 = F_r$$

Symbols

$C_{0\text{req}}$ = requisite basic static load rating [kN]
 F_a = axial load [kN]
 F_r = radial load [kN]
 f_T = temperature factor (→ **table 4**)
 P_0 = equivalent static bearing load [kN]

Design of associated components

The shields in 2Z/VA208 and 2Z/VA228 design deep groove ball bearings guide the graphite cage axially. Therefore, the shields should be supported by the housing shoulder or a spacer ring with a bore diameter smaller than the outer ring shoulder diameter D_2 (→ **product tables**). If this is not possible, a support washer with the appropriate bore diameter should be installed between the bearing and housing shoulder or spacer ring (→ **fig. 5**).

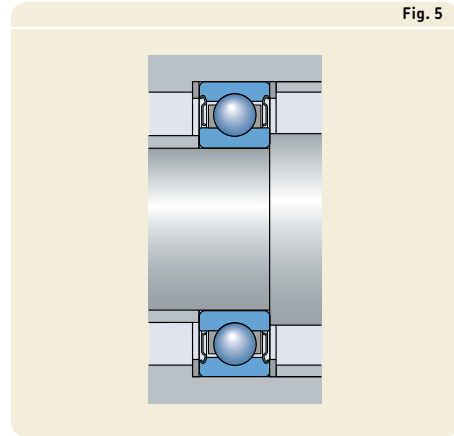

Table 4

Temperature factor f_T

Operating temperature		Factor f_T
$^{\circ}\text{C}$	$^{\circ}\text{F}$	
150	300	1
200	390	0,9
250	480	0,75
300	570	0,6
350	660	0,45

Maintenance

Bearings for extreme temperatures with a shield on both sides do not have a relubrication facility as they are lubricated for the life of the bearing.

Open VA201 design deep groove ball bearings should be inspected after some six months of operation. It is sufficient to open the housing, or in the case of kiln trucks, to withdraw the wheel with the bearing from the journal and to remove contaminants. If there is no longer a lubricant film indicated by a shiny metallic track on the raceways, the bearing should be relubricated using the original high-temperature paste.

Prior to relubrication, the bearing should be cleaned carefully. Do not spin the bearings when drying them with compressed air.

Designation system

Refer to *Designation system* in the relevant product chapter (→ **page 320** for deep groove ball bearings and **page 456** for Y-bearings).

Additional designation suffixes used with SKF bearings for extreme temperatures are explained in the following.

- VA201** Bearing for extreme temperatures with a stamped steel cage, lubricated with a polyalkylene glycol/graphite mixture
- VA208** Bearing for extreme temperatures with a segmented cage made of graphite
- VA228** Bearing for extreme temperatures with a coronet cage made of graphite
- 2F** Shield and flinger on both sides
- 2Z** Shield on both sides
- W** Bearing without lubrication hole(s)

15B.1 Single row deep groove ball bearings for extreme temperatures d 10 – 65 mm

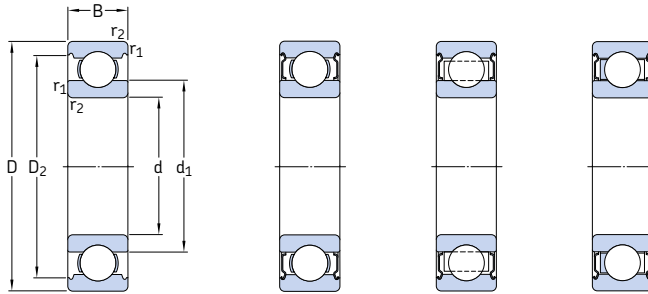

VA201

2Z/VA201

2Z/VA208

2Z/VA228

Dimensions						Basic static load rating	Limiting speed	Mass	Designation	
d	D	B	d ₁	D ₂	r _{1,2} min.	C ₀				
mm						kN	r/min	kg	-	
10	35	11	17,5	28,7	0,6	3,4	400	0,053	6300-2Z/VA201	
12	32	10	18,4	27,4	0,6	3,1	400	0,037	6201/VA201	
	32	10	18,4	27,4	0,6	3,1	400	0,037	6201-2Z/VA201	
	32	10	18,4	27,4	0,6	3,1	400	0,037	6201-2Z/VA228	
15	35	11	21,7	30,4	0,6	3,75	360	0,045	6202/VA201	
	35	11	21,7	30,4	0,6	3,75	360	0,045	6202-2Z/VA201	
	35	11	21,7	30,4	0,6	3,75	360	0,045	6202-2Z/VA228	
17	35	10	23	31,2	0,3	3,25	340	0,038	6003/VA201	
	35	10	23	31,2	0,3	3,25	340	0,038	6003-2Z/VA201	
	35	10	23	31,2	0,3	3,25	170	0,038	6003-2Z/VA208	
	40	12	24,5	35	0,6	4,75	310	0,065	6203/VA201	
	40	12	24,5	35	0,6	4,75	310	0,065	6203-2Z/VA201	
	40	12	24,5	35	0,6	4,75	310	0,065	6203-2Z/VA228	
	47	14	26,5	39,6	1	6,55	280	0,11	6303/VA201	
	47	14	26,5	39,6	1	6,55	280	0,11	6303-2Z/VA228	
	20	42	12	27,2	37,2	0,6	5	290	0,067	6004/VA201
42		12	27,2	37,2	0,6	5	140	0,067	6004-2Z/VA208	
47		14	28,8	40,6	1	6,55	260	0,031	6204/VA201	
47		14	28,8	40,6	1	6,55	260	0,031	6204-2Z/VA201	
47		14	28,8	40,6	1	6,55	260	0,031	6204-2Z/VA228	
52		15	30,3	44,8	1,1	7,8	250	0,14	6304/VA201	
52		15	30,3	44,8	1,1	7,8	250	0,14	6304-2Z/VA201	
52		15	30,3	44,8	1,1	7,8	250	0,14	6304-2Z/VA228	
25		47	12	32	42,2	0,6	6,55	250	0,078	6005/VA201
		47	12	32	42,2	0,6	6,55	250	0,078	6005-2Z/VA201
	47	12	32	42,2	0,6	6,55	120	0,078	6005-2Z/VA208	
	52	15	34,3	46,3	1	7,8	230	0,13	6205/VA201	
	52	15	34,3	46,3	1	7,8	230	0,13	6205-2Z/VA201	
	52	15	34,3	46,3	1	7,8	230	0,13	6205-2Z/VA228	
	62	17	36,6	52,7	1,1	11,6	200	0,23	6305/VA201	
	62	17	36,6	52,7	1,1	11,6	200	0,23	6305-2Z/VA228	

Dimensions						Basic static load rating C ₀	Limiting speed	Mass	Designation
d	D	B	d ₁	D ₂	r _{1,2} min.				
mm						kN	r/min	kg	-
30	55	13	38,2	49	1	8,3	100	0,12	6006-2Z/VA208
	62	16	40,3	54,1	1	11,2	190	0,2	6206/VA201
	62	16	40,3	54,1	1	11,2	190	0,2	6206-2Z/VA201
	62	16	40,3	54,1	1	11,2	190	0,2	6206-2Z/VA228
	72	19	44,6	61,9	1,1	16	170	0,35	6306/VA201
	72	19	44,6	61,9	1,1	16	170	0,35	6306-2Z/VA228
35	72	17	46,9	62,7	1,1	15,3	160	0,29	6207/VA201
	72	17	46,9	62,7	1,1	15,3	160	0,29	6207-2Z/VA201
	72	17	46,9	62,7	1,1	15,3	160	0,29	6207-2Z/VA228
	80	21	49,5	69,2	1,5	19	150	0,46	6307/VA201
	80	21	49,5	69,2	1,5	19	70	0,46	6307-2Z/VA208
40	68	15	49,2	61,1	1	11	80	0,19	6008-2Z/VA208
	80	18	52,6	69,8	1,1	19	150	0,37	6208/VA201
	80	18	52,6	69,8	1,1	19	150	0,37	6208-2Z/VA201
	80	18	52,6	69,8	1,1	19	150	0,37	6208-2Z/VA228
	90	23	56,1	77,7	1,5	24	130	0,63	6308/VA201
	90	23	56,1	77,7	1,5	24	130	0,63	6308-2Z/VA201
45	85	19	57,6	75,2	1,1	21,6	130	0,42	6209/VA201
	85	19	57,6	75,2	1,1	21,6	130	0,42	6209-2Z/VA201
	85	19	57,6	75,2	1,1	21,6	130	0,42	6209-2Z/VA228
	100	25	62,1	86,7	1,5	31,5	120	0,84	6309/VA201
	100	25	62,1	86,7	1,5	31,5	60	0,84	6309-2Z/VA208
	50	80	16	59,7	72,8	1	16	60	0,26
90		20	62,5	81,7	1,1	23,2	120	0,45	6210/VA201
90		20	62,5	81,7	1,1	23,2	120	0,45	6210-2Z/VA201
90		20	62,5	81,7	1,1	23,2	120	0,45	6210-2Z/VA228
110		27	68,7	95,2	2	38	110	1,1	6310/VA201
110		27	68,7	95,2	2	38	110	1,1	6310-2Z/VA201
55	90	18	66,3	81,5	1,1	21,2	120	0,39	6011-2Z/VA201
	90	18	66,3	81,5	1,1	21,2	60	0,39	6011-2Z/VA208
	100	21	69	89,4	1,5	29	110	0,61	6211/VA201
	100	21	69	89,4	1,5	29	110	0,61	6211-2Z/VA201
	100	21	69	89,4	1,5	29	110	0,61	6211-2Z/VA228
	120	29	75,3	104	2	45	100	1,35	6311/VA201
60	110	22	75,5	98	1,5	36	100	0,78	6212/VA201
	110	22	75,5	98	1,5	36	100	0,78	6212-2Z/VA201
	110	22	75,5	98	1,5	36	100	0,78	6212-2Z/VA228
	130	31	81,8	113	2,1	52	90	1,7	6312/VA201
	130	31	81,8	113	2,1	52	40	1,7	6312-2Z/VA208
	65	120	23	83,3	106	1,5	40,5	90	1
120		23	83,3	106	1,5	40,5	90	1	6213-2Z/VA201
120		23	83,3	106	1,5	40,5	40	1	6213-2Z/VA208
120		23	83,3	106	1,5	40,5	90	1	6213-2Z/VA228
140		33	88,3	122	2,1	60	80	2,1	6313/VA201
140		33	88,3	122	2,1	60	80	2,1	6313-2Z/VA201
140	33	88,3	122	2,1	60	40	2,1	6313-2Z/VA208	
140	33	88,3	122	2,1	60	80	2,1	6313-2Z/VA228	

15B.1 Single row deep groove ball bearings for extreme temperatures d 70 – 120 mm

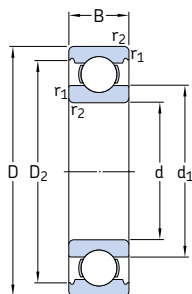

VA201

2Z/VA201

2Z/VA208

2Z/VA228

Dimensions						Basic static load rating	Limiting speed	Mass	Designation
d	D	B	d ₁	D ₂	r _{1,2} min.	C ₀			
mm						kN	r/min	kg	–
70	125	24	87	111	1,5	45	90	1,1	6214/VA201
	125	24	87	111	1,5	45	90	1,1	6214-2Z/VA201
	125	24	87	111	1,5	45	40	1,1	6214-2Z/VA208
	125	24	87	111	1,5	45	90	1,1	6214-2Z/VA228
	150	35	94,9	130	2,1	68	80	2,55	6314/VA201
	150	35	94,9	130	2,1	68	40	2,55	6314-2Z/VA208
75	130	25	92	117	1,5	49	80	1,2	6215/VA201
	130	25	92	117	1,5	49	80	1,2	6215-2Z/VA201
	130	25	92	117	1,5	49	40	1,2	6215-2Z/VA208
	130	25	92	117	1,5	49	80	1,2	6215-2Z/VA228
	160	37	101	139	2,1	76,5	70	3,05	6315/VA201
	160	37	101	139	2,1	76,5	30	3,05	6315-2Z/VA208
80	140	26	101	127	2	55	40	1,45	6216-2Z/VA208
	170	39	108	147	2,1	86,5	30	3,65	6316-2Z/VA208
85	150	28	106	135	2	64	70	1,8	6217/VA201
	150	28	106	135	2	64	30	1,8	6217-2Z/VA208
90	160	30	112	143	2	73,5	70	2,2	6218-2Z/VA228
95	170	32	118	152	2,1	81,5	60	2,6	6219/VA201
	170	32	118	152	2,1	81,5	60	2,6	6219-2Z/VA201
	170	32	118	152	2,1	81,5	60	2,6	6219-2Z/VA228
100	150	24	115	139	1,5	54	30	1,25	6020-2Z/VA208
	180	34	124	160	2,1	93	60	3,15	6220/VA201
	180	34	124	160	2,1	93	30	3,15	6220-2Z/VA208
	180	34	124	160	2,1	93	60	3,15	6220-2Z/VA228
110	170	28	129	156	2	73,5	30	1,95	6022-2Z/VA208
120	180	28	139	166	2	80	30	2,1	6024-2Z/VA208

15B.2 Y-bearings for extreme temperatures, metric shafts d 20 – 80 mm

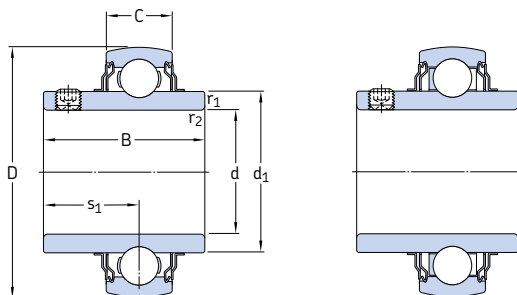

VA201

VA228

Dimensions							Basic static load rating C_0	Limiting speed	Mass	Designations	
d	D	B	C	d_1	s_1	$r_{1,2}$ min.				Bearing with stamped steel cage	coronet cage of graphite
mm							kN	r/min	kg	-	
20	47	31	14	28,2	18,3	0,6	6,55	260	0,14	YAR 204-2FW/VA201	YAR 204-2FW/VA228
25	52	34,1	15	33,7	19,8	0,6	7,8	230	0,17	YAR 205-2FW/VA201	YAR 205-2FW/VA228
30	62	38,1	18	39,7	22,2	0,6	11,2	190	0,28	YAR 206-2FW/VA201	YAR 206-2FW/VA228
35	72	42,9	19	46,1	25,4	1	15,3	160	0,41	YAR 207-2FW/VA201	YAR 207-2FW/VA228
40	80	49,2	21	51,8	30,2	1	19	150	0,55	YAR 208-2FW/VA201	YAR 208-2FW/VA228
45	85	49,2	22	56,8	30,2	1	21,6	130	0,6	YAR 209-2FW/VA201	YAR 209-2FW/VA228
50	90	51,6	22	62,5	32,6	1	23,2	120	0,69	YAR 210-2FW/VA201	YAR 210-2FW/VA228
55	100	55,6	25	69	33,4	1	29	110	0,94	YAR 211-2FW/VA201	YAR 211-2FW/VA228
60	110	65,1	26	75,6	39,7	1,5	36	100	1,3	YAR 212-2FW/VA201	YAR 212-2FW/VA228
75	130	73,1	29	92	46,3	1,5	49	80	2,05	-	YAR 215-2FW/VA228
80	140	77,9	30	97,4	47,6	2	53	80	2,45	-	YAR 216-2FW/VA228

15B.3 Y-bearings for extreme temperatures, inch shafts

d $\frac{3}{4}$ – 3 in.

19,05 – 76,2 mm

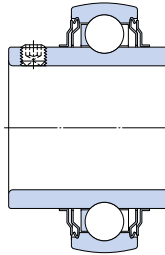
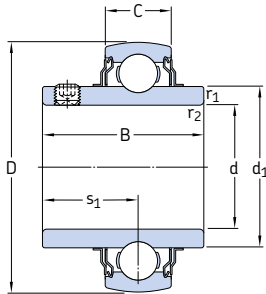

VA201

VA228

Dimensions							Basic static load rating C_0	Limiting speed	Mass	Designations	
d	D	B	C	d_1	s_1	Bearing with stamped steel cage				coronet cage of graphite	
in./mm							kN	r/min	kg	-	
$\frac{3}{4}$ 19,05	47	31	14	28,2	18,3	0,6	6,55	270	0,14	YAR 204-012-2FW/VA201	YAR 204-012-2FW/VA228
1 25,4	52	34,1	15	33,7	19,8	0,6	7,8	230	0,17	YAR 205-100-2FW/VA201	YAR 205-100-2FW/VA228
$1\frac{3}{16}$ 30,163	62	38,1	18	39,7	22,2	0,6	11,2	190	0,27	YAR 206-103-2FW/VA201	YAR 206-103-2FW/VA228
$1\frac{1}{4}$ 31,75	72	42,9	19	46,1	25,4	1	15,3	170	0,46	YAR 207-104-2FW/VA201	YAR 207-104-2FW/VA228
$1\frac{7}{16}$ 36,513	72	42,9	19	46,1	25,4	1	15,3	160	0,38	YAR 207-107-2FW/VA201	YAR 207-107-2FW/VA228
$1\frac{1}{2}$ 38,1	80	49,2	21	51,8	30,2	1	19	150	0,59	YAR 208-108-2FW/VA201	YAR 208-108-2FW/VA228
$1\frac{11}{16}$ 42,863	85	49,2	22	56,8	30,2	1	21,6	140	0,66	YAR 209-111-2FW/VA201	YAR 209-111-2FW/VA228
$1\frac{3}{4}$ 44,45	85	49,2	22	56,8	30,2	1	21,6	130	0,62	YAR 209-112-2FW/VA201	YAR 209-112-2FW/VA228
$1\frac{15}{16}$ 49,213	90	51,6	22	62,5	32,6	1	23,2	120	0,71	YAR 210-115-2FW/VA201	YAR 210-115-2FW/VA228
2 50,8	100	55,6	25	69	33,4	1	29	110	0,94	YAR 211-200-2FW/VA201	YAR 211-200-2FW/VA228
$2\frac{3}{16}$ 55,563	100	55,6	25	69	33,4	1	29	110	0,92	YAR 211-203-2FW/VA201	YAR 211-203-2FW/VA228
$2\frac{7}{16}$ 61,913	110	65,1	26	75,6	39,7	1,5	36	100	1,25	YAR 212-207-2FW/VA201	YAR 212-207-2FW/VA228
	125	69,9	28	87	39,7	1,5	45	90	1,85	-	YAR 214-207-2FW/VA228
$2\frac{15}{16}$ 74,613	130	73,1	29	92	46,1	1,5	49	80	2,05	-	YAR 215-215-2FW/VA228
3 76,2	140	77,9	30	97,4	47,7	2	53	80	2,45	-	YAR 216-300-2FW/VA228



15C Bearings with Solid Oil

Features of Solid Oil	1186
Bearings and bearing units with Solid Oil	1186
Solid Oil variants	1186
Sealing solutions	1187
Bearing data	1188
Dimension standards, tolerances, internal clearance	1188
Loads	1188
Minimum load	1188
Load carrying capacity	1188
Temperature limits	1188
Speed limits	1189
Designation system	1189

15C Bearings with Solid Oil

In most applications, adequate amounts of grease and oil are provided to a bearing. However, in cases where accessibility to the bearing for relubrication purposes is impractical or impossible, Solid Oil is an excellent solution. Solid Oil can also be used effectively in applications where premature bearing failure is the result of high levels of contamination.

Typical conditions where Solid Oil is used include:

- wet and dirty environments
- vertical shaft arrangements
- applications exposed to g-forces
- special hygienic requirements
- oscillating movements
- bearings that are difficult to access for relubrication

Features of Solid Oil

Solid Oil is an oil-saturated, polymer matrix that fills the entire free space in the bearing, encapsulating both the rolling elements and cage(s). The polymer material has a porous structure, with millions of micro-pores, to hold the lubricating oil. The pores are so small that the oil is retained in the material by surface tension. As the oil-filled polymer material is injected into the bearing, a very narrow gap forms around the rolling elements and raceways enabling the bearing components to rotate freely.

More information

Bearing life and load ratings. 63

Design considerations 159

Bearing systems. 160

Recommended fits 169

Abutment and fillet dimensions. 208

Mounting, dismounting and bearing care 271

Mounting instructions for individual bearings → skf.com/mount

When Solid Oil slides against the rolling elements or raceways of a bearing, the metal is coated with an even and consistent film of oil. Then, with only a moderate increase in operating temperature, oil is pushed toward the surface of the polymer matrix. This “flow” of oil within the polymer matrix occurs because the oil has a higher coefficient of thermal expansion than the polymer matrix and because the viscosity of the oil decreases with increasing temperature. When the bearing stops running, excess oil is reabsorbed into the polymer matrix.

A bearing with Solid Oil contains two to four times more oil than conventional grease lubricated bearings. This is because the bearing is entirely filled with Solid Oil, whereas a grease lubricated bearing normally operates with approximately one third of its free space filled with grease.

Because Solid Oil fills the bearing entirely, it is difficult for solid or liquid contaminants to reach the bearing contact surfaces, even without bearing seals. In highly contaminated environments, however, SKF recommends using bearings with Solid Oil and integral contact seals.

Bearings and bearing units with Solid Oil

Most SKF ball and roller bearings as well as bearing units (→ **fig. 1**) can be supplied with Solid Oil.

Some needle roller bearings and bearings fitted with a large-volume cage are less suitable for Solid Oil because there is too little free space left for Solid Oil inside the bearing.

Solid Oil variants

The standard oil used for Solid Oil is a high-quality synthetic oil (designation suffix W64, → **table 1**), which meets the needs of most applications.

Oils with other viscosities and characteristics are also available (→ **table 1**). These special oils or additives are typically used in the following applications:

- food and pharmaceutical manufacturing and packaging (designation suffix W64F)

Fig. 1



Table 1

Technical specifications of variants of SKF Solid Oil bearings and bearing units

Suffix	Base oil type	Base oil viscosity [mm ² /s] at 40 °C (105 °F)	Base oil viscosity [mm ² /s] at 100 °C (210 °F)	Minimum start-up temperature	Polymer colour	Properties
W64	Synthetic	140	18	-40 °C (-40 °F)	Blue	Standard variant
W64F	Synthetic	220	25	-20 °C (5 °F)	White	NSF H1 approved for food applications
W64H	Synthetic	930	80	-10 °C (15 °F)	Blue	Slow speed
W64L	Synthetic	32	6	-50 °C (-60 °F)	White	Low temperature

- slow-speed applications (designation suffix W64H)
- low temperature applications (designation suffix W64L)

For additional information about Solid Oil, contact the SKF application engineering service.

Sealing solutions

Deep groove ball bearings with Solid Oil are available capped with one of the following sealing solutions:

- a shield on one side (designation suffix Z)
- a contact NBR seal on both sides (designation suffix 2RS1 or 2RSH)

For additional information, refer to *Sealing solutions* (→ page 300).

For other capped bearings and bearing units with Solid Oil, refer to the product chapter of the relevant standard bearing.

Bearing data

Dimension standards, tolerances, internal clearance

Dimensions, tolerances and internal clearance of bearings or units with Solid Oil are the same as for the corresponding standard products.

Loads

Minimum load

The weight of the components supported by the bearing, together with external forces, generally exceed the requisite minimum load. If this is not the case, the bearing must be subjected to an additional radial load.

The minimum load for bearings with Solid Oil should be slightly higher than the minimum load for standard bearings. Recommendations for calculating the requisite minimum loads for the different standard bearing types are provided in the relevant product chapter.

Load carrying capacity

The basic dynamic and static load ratings for bearings with Solid Oil are the same as for same-sized standard bearings.

Temperature limits

The temperature limits for bearings with Solid Oil are valid for both open and capped bearings. The relevant limits are:

- minimum (→ **table 1, page 1187**)
- maximum 85 °C (185 °F) for continuous operating conditions
- maximum 95 °C (205 °F) for intermittent operating conditions

If bearings with Solid Oil are to be hot mounted, SKF does not recommend heating the bearing above 80 °C (175 °F). However, if higher temperatures are necessary, make sure that the temperature does not exceed the permissible temperature of either the seal or Solid Oil, whichever is lowest. If an induction heater is used, mounting temperatures of up to 120 °C (250 °F) are permissible.

Speed limits

The limiting speeds for bearings and bearing units with Solid Oil are listed in **table 2** by the speed factor A.

As the frictional heat increases with speed, it might be necessary to limit the speed of a high-temperature application, so as not to exceed the Solid Oil temperature limit.

Designation system

Refer to *Designation system* in the relevant product chapter of the standard bearing.

The designation suffixes used to identify SKF bearings with Solid Oil are explained in the following.

- W64** Synthetic base oil type, standard variant
- W64F** Synthetic base oil type, NSF H1 approved for food applications
- W64H** Synthetic base oil type, for slow speeds
- W64L** Synthetic base oil type, for low temperatures

Additional sealing suffixes used with SKF bearings with Solid Oil are explained in the following.

- Z** Shield on one side
- 2RS1** Contact seal, NBR, on both sides
- 2RSH** Contact seal, NBR, on both sides

Table 2

Recommended limits for the speed factor of bearings and bearing units with Solid Oil

Bearing type	Speed factor A
–	mm/min
Deep groove ball bearings	
– single row with a stamped metal cage	300 000
– single row with a polymer cage	40 000
– double row	40 000
Angular contact ball bearings	
– with a stamped metal cage	150 000
– with a polymer cage	40 000
Self-aligning ball bearings	
– with a stamped metal cage	150 000
– with a polymer cage	40 000
Cylindrical roller bearings	
– with a stamped metal cage	150 000
– with a polymer cage	40 000
Tapered roller bearings	45 000
Spherical roller bearings	
– E design	42 500
– CC design	85 000
Y-bearings, Y-bearing units	40 000

A = speed factor [mm/min]
 $= n d_m$
 n = rotational speed [r/min]
 d_m = bearing mean diameter [mm]
 $= 0,5 (d + D)$

For sealed bearings, 80% of the quoted speed factors should be used.



15D SKF DryLube bearings

SKF DryLube bearings	1192
Assortment.....	1193
Designs and variants	1194
Bearing data	1197
(Dimension standards, tolerances, radial internal clearance, stabilization, misalignment, filling grade of dry lubricant)	
Selecting bearing size	1200
Temperature limits	1201
Speed limits	1202
Design of bearing arrangements	1202
Mounting	1202
Maintenance	1203
Designation system	1203

SKF DryLube bearings

SKF DryLube bearings are designed to reduce machine operating costs, extend maintenance intervals and provide a high degree of operational reliability, especially at extremely high temperatures. SKF DryLube bearings are filled with a dry lubricant, based on graphite and molybdenum disulfide (MoS_2) and a resin binder. The dry lubricant is injected into the free space of the bearing and cured until it solidifies (→ **figs. 1** and **2**). The dry lubricant can protect the rolling elements and raceways from damage caused by solid contaminants.

During operation, the dry lubricant maintains a very thin film on the raceways and rolling elements to avoid metal-to-metal contact. After a while, small fragments of solid lubricant may break free and temporarily increase noise and vibration levels. This does not reduce the performance or service life of the bearing.



SKF DryLube bearings provide the following benefits:

- effective lubrication for high temperature applications
- low start-up torque at any temperature and low frictional moment during operation
- higher speed capabilities than bearings for extreme temperatures with a graphite cage
- lubricated for the life of the bearing
- minimal lubricant loss
- suitable for extremely slow rotating speeds and oscillating movements
- improved worker safety and environmentally friendly compared to many oils and greases

More information

Design considerations	159
Bearing systems	160
Recommended fits	169
Abutment and fillet dimensions	208

Mounting, dismantling and bearing care	271
---	------------



Typical applications where SKF DryLube bearings are used include:

- metals industry (rolls in bloom and billet casters, cooling and roll out tables, guide rolls in bar mills, reheating furnaces rolls)
- industrial ovens (kiln truck wheel bearings, roller hearth furnaces and chain bearings for hardening and annealing ovens)
- food and beverage industry (ovens, smoke-house conveyor lines, wafer machines, sterilization equipment)
- paint lines for automotive and powder coating
- paper industry (paper converting lines, rope sheaves)

Assortment

Most SKF rolling bearings and bearing units can be supplied as SKF DryLube bearings provided the bearing is fitted with a sheet metal cage and is available with internal clearance greater than Normal.

The assortment of SKF DryLube bearings mentioned in this catalogue includes:

- deep groove ball bearings
- Y-bearings
- angular contact ball bearings
- cylindrical roller bearings
- tapered roller bearings
- spherical roller bearings
- thrust ball bearings
- spherical roller thrust bearings

For self-aligning ball bearings or customized units filled with dry lubricant, contact the SKF application engineering service.

For the assortment of deep groove ball bearings and Y-bearings with dry lubricant not described here, refer to *Bearings for extreme temperatures* (→ **page 1169**).

Designs and variants

SKF DryLube bearings are available in three main variants to deliver superior performance, based on the operating conditions of the application (→ **table 1**). The bearings are filled with a dry lubricant based on graphite and molybdenum disulfide. To further increase speed capabilities or extend bearing service life, nano particles and perfluoro polyether (PFPE) oil additives are also available (→ **table 1**).

Deep groove ball bearings and Y-bearings in certain series and sizes are also available with manganese phosphate coated rings, rolling elements and cages to enhance adhesion of the dry lubricant to the metal and provide additional protection against corrosion (→ **fig. 2, page 1193**).

WARNING

PFPE (perfluoro polyether) oil is very stable and harmless under normal operating conditions up to 250 °C (480 °F). However, if exposed to extreme temperatures above 300 °C (570 °F), PFPE oils give off hazardous fumes. These fumes can be harmful to the eyes and to the lungs, if inhaled.

The following safety precautions should be observed:

- Follow the safety precautions in the appropriate material safety data sheet (MSDS).
- If there is a risk of human exposure and the operating temperature is above 300 °C (570 °F), appropriate ventilation is required.

If the fumes have been inhaled, contact a doctor immediately.

The user is responsible for the correct use of the product during its service life and its proper disposal. SKF takes no responsibility for the improper handling of bearings with PFPE oil additives or for any injury resulting from their use.

Table 1

Characteristics of SKF DryLube bearings

	Variants					
	VA260	VA210	VA261	VA2101	VA267	VA237
Phosphated rings, rolling elements and cages¹⁾	Yes	–	Yes	–	Yes	–
Lubrication						
Graphite-based lubricant	Yes		Yes		Yes	
Perfluoro polyether (PFPE) oil additive	–		Yes		Yes	
Nano particles	–		–		Yes	
NSF H1 food grade	Yes		–		–	
Dry lubricant only	Yes		–		–	
Temperature limits						
Minimum	–60 °C (–75 °F)		–60 °C (–75 °F)		–60 °C (–75 °F)	
Maximum						
• open bearings	250 °C (480 °F)		250 °C (480 °F)		250 °C (480 °F)	
• bearings with a shield on both sides (designation suffix ZZ) ²⁾	350 °C (660 °F)		350 °C (660 °F)		350 °C (660 °F)	
Limiting speed [r/min]						
• Radial ball bearings	$\frac{15\,000}{d_m}$		$\frac{60\,000}{d_m}$		$\frac{120\,000}{d_m}$	
• Radial roller bearings	$\frac{7\,500}{d_m}$		$\frac{30\,000}{d_m}$		$\frac{60\,000}{d_m}$	
• Thrust bearings	$\frac{3\,750}{d_m}$		$\frac{15\,000}{d_m}$		$\frac{30\,000}{d_m}$	

d_m = bearing mean diameter [mm]
 $= 0,5 (d + D)$

¹⁾ Available only for certain series and sizes of deep groove ball bearings and Y-bearings.

²⁾ Also applicable for bearings with dry lubricant only between the inner ring (or the shaft washer) and cage (→ *Bearing data*, page 1196) or bearings with a metal seal on both sides (→ fig. 66, page 236).

Bearing data

	Deep groove ball bearings	Y-bearings	Angular contact ball bearings	Cylindrical roller bearings
Dimension standards	Refer to the product chapter of the relevant standard bearing.			
Tolerances	Refer to the product chapter of the relevant standard bearing. There may be slight deviations for phosphated bearings ¹⁾ from the ...			
Radial internal clearance	Multiples of C5 (→ table 2, page 1198) Check availability for C3, C4 or C5	Twice C5 of deep groove ball bearings (→ table 2, page 1198)	–	C3, C4, C5
For additional information (→ page 149)	Guidelines for the initial clearance: (→ diagram 1, page 1199)			Guidelines for the initial clearance: (→ diagram 2, page 1199)
Stabilization	120 °C (250 °F)	120 °C (250 °F)	120 °C (250 °F)	150 °C (300 °F)
For additional information (→ page 82)	The rings, rolling elements and cages of SKF DryLube bearings undergo the same heat stabilization process as the relevant standard bearing. As a result, for higher operating temperatures a certain amount of dimensional change is to be expected and must be taken into account when determining ...			
Misalignment	Refer to the product chapter of the relevant standard bearing.			
Filling grade of dry lubricant	Entire free space in the bearing			

¹⁾ Available only for certain series and sizes of deep groove ball bearings and Y-bearings.

	Tapered roller bearings	Spherical roller bearings	Thrust ball bearings	Spherical roller thrust bearings
... standard tolerances. These deviations do not effect mounting or bearing operation.				
	–	C3, C4, C5	–	–
		Guidelines for the initial clearance: (→ diagram 3, page 1199).		
	120 °C (250 °F)	200 °C (390 °F)	120 °C (250 °F)	200 °C (390 °F)
... the initial internal clearance of the bearing. For high-speed applications operating at very high temperatures, special stabilization of the bearing rings may be necessary. For additional information, contact the SKF application engineering service.				
	Free space between the inner ring and cage	<ul style="list-style-type: none"> • E design (d ≤ 65 mm) and CC design: free space between the inner ring and cages • Other bearings: entire free space in the bearing 	<ul style="list-style-type: none"> • 511 series (d ≥ 90 mm) and 514 series (d ≥ 50 mm): entire free space in the bearing • Other bearings: free space between the shaft washer and cage 	Free space between the shaft washer and cage

15D SKF DryLube bearings

Table 2

Radial internal clearance of SKF DryLube bearings

Bore diameter		Radial internal clearance			
d over	incl.	Deep groove ball bearings		Y-bearings	
		min.	max.	min.	max.
mm		µm			
	10	40	136	–	–
10	18	50	160	–	–
18	24	56	172	56	96
24	30	60	192	60	106
30	40	80	236	80	128
40	50	90	272	90	146
50	65	110	340	110	180
65	80	130	400	–	–
80	120	150	460	–	–

Diagram 1

Selection guidelines for initial clearance of SKF DryLube deep groove ball bearings

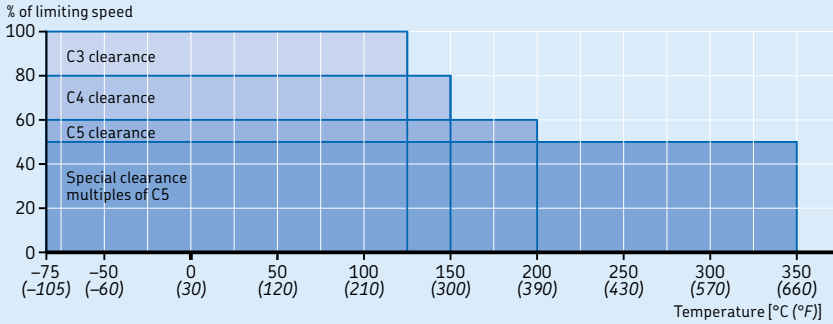

Valid for bearings stabilized up to 120 °C (250 °F).

Diagram 2

Selection guidelines for initial clearance of SKF DryLube cylindrical roller bearings

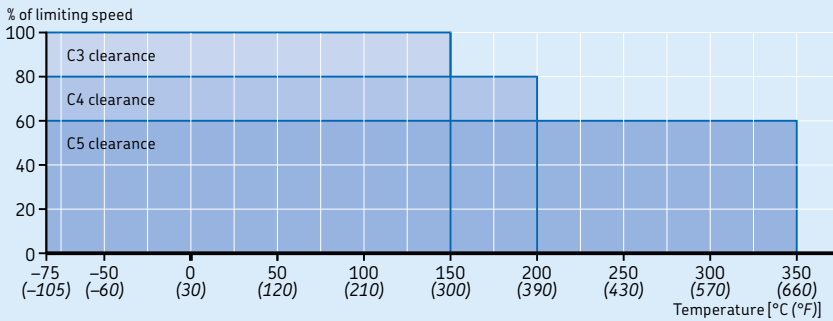

Valid for bearings stabilized up to 150 °C (300 °F).

Diagram 3

Selection guidelines for initial clearance of SKF DryLube spherical roller bearings

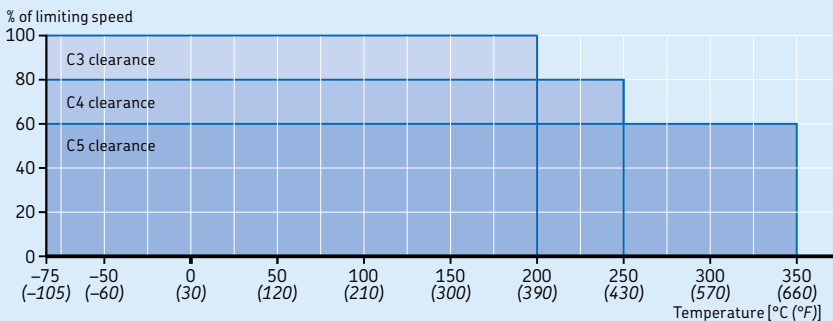

Valid for bearings stabilized up to 200 °C (390 °F).

Selecting bearing size

The requisite bearing size for rotating bearings can be determined based on the basic dynamic load rating C (→ **product tables**).

The corresponding standard bearing should have a C value \geq the requisite value.

However, the basic static load rating C_0 (→ **product tables**) is to be used when the bearings are to:

- rotate at very slow speeds ($n < 10$ r/min)
- perform very slow oscillating movements
- be stationary under load for extended periods

The corresponding standard bearing should have a C_0 value \geq the requisite value.

Calculating the requisite basic dynamic load rating	Calculating the requisite basic static load rating	Symbols
$C_{req} = S_{req} \frac{P}{f_T}$	$C_{0req} = 2 \frac{P_0}{f_T}$	C_{req} = requisite basic dynamic load rating [kN]
To calculate P , refer to the product chapter of the relevant standard bearing.	To calculate P_0 , refer to the product chapter of the relevant standard bearing.	C_{0req} = requisite basic static load rating [kN]
$P < F_r \rightarrow P = F_r$	$P_0 < F_r \rightarrow P_0 = F_r$	F_a = axial load [kN] F_r = radial load [kN] f_T = temperature factor (→ table 3)
For deep groove ball bearings, F_a should not exceed $0,15 C_0$.		P = equivalent dynamic bearing load [kN] P_0 = equivalent static bearing load [kN] S_{req} = guideline value for dynamic load safety factor (→ table 4)

Table 3

Temperature factor f_T		
Operating temperature		Factor f_T
$^{\circ}\text{C}$	$^{\circ}\text{F}$	
150	300	1
200	390	0,9
250	480	0,75
300	570	0,6
350	660	0,45

Temperature limits

The graphite-based lubricant in SKF DryLube bearings is effective at temperatures up to 500 °C (930 °F). At temperatures above 250 °C (480 °F), the resin binder begins to degrade, but the dry lubricant continues to lubricate. Therefore, for continuous operation at temperatures above 250 °C (480 °F), SKF recommends using bearings with a shield on both sides (designation suffix 2Z), or with a metal seal on both sides (→ **fig. 66, page 236**) to keep the lubricant in the bearing. Bearings with dry lubricant only between the inner ring (or the shaft washer) and cage (→ *Bearing data, page 1196*) may work at elevated temperatures without shields.

The recommended temperature limits are listed in **table 1** (→ **page 1195**).

Table 4

Guideline values for dynamic load safety factor S_{req}	
Application	S_{req}
Machines used for short periods or intermittently: cooling beds, guide rolls	3
Machines used for short periods or intermittently where high operational reliability is required: cranes in metals applications	5
Machines in use 8 hours per day and fully utilized: conveyor belts, hardening and annealing ovens	10
Machines in use 24 hours per day: conveyor systems, equipment in continuous casting mills	12

Speed limits

The limiting speed for the different variants of SKF DryLube bearings can be calculated using the formulae listed in **table 1** (→ **page 1195**).

Diagram 4 provides estimated values. If the bearing clearance is greater than C3, the limiting speed should be reduced according to **diagrams 1 to 3** (→ **page 1199**).

Design of bearing arrangements

SKF DryLube bearings for extreme temperatures can be mounted with a loose or an interference fit on the shaft and in the housing. However, either the inner or outer ring should be mounted with an interference fit, to locate the shaft and provide satisfactory support (→ **table 5**).

Mounting

Mounting with mechanical force might crack the dry lubricant. Therefore, SKF DryLube bearings should always be hot mounted to reduce the mounting force.

For additional information, refer to *Mounting, dismantling and bearing care* (→ **page 271**) or the product chapter of the relevant standard bearing.

Diagram 4

Guidelines for limiting speeds of SKF DryLube radial ball bearings

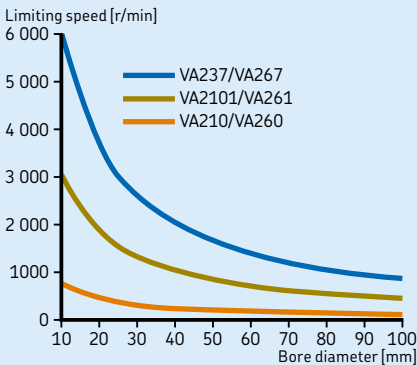

Reduce the limiting speed to 50% for radial roller bearings and to 25% for thrust bearings.

Table 5

Fits for SKF DryLube bearings on solid steel shafts or in cast iron and steel housings

Load condition	Tolerance class ¹⁾
Rotating inner ring load	
Shaft diameter	k5 ²⁾
Housing bore	F7
Stationary inner ring load	
Shaft diameter	g6
Housing bore	J7

¹⁾ All ISO tolerance classes are valid with the envelope requirement (such as H7(Ⓢ)) in accordance with ISO 14405-1.

²⁾ For d > 100 mm, contact the SKF application engineering service.

Maintenance

SKF DryLube bearings do not have a relubrication facility as they are lubricated for the life of the bearing.

Designation system

Refer to *Designation system* in the relevant product chapter of the standard bearing.

The designation suffixes used to identify SKF DryLube bearings are part of group 4.6 (→ **diagram 3, page 44**) in the designation system. They are explained in the following.

- VA210** Graphite-based lubricant
- VA2101** Graphite-based lubricant and PFPE oil additive
- VA237** Graphite-based lubricant, PFPE oil additive and nano particles
- VA260** Graphite-based lubricant; rings, rolling elements and cage(s) phosphated
- VA261** Graphite-based lubricant and PFPE oil additive; rings, rolling elements and cage(s) phosphated
- VA267** Graphite-based lubricant, PFPE oil additive and nano particles; rings, rolling elements and cage(s) phosphated

The following additional suffixes used with SKF DryLube bearings are part of group 4.4 (→ **diagram 3, page 44**) in the designation system. They are explained in the following.

- S1** Bearing rings heat stabilized for operating temperatures $\leq 200\text{ °C}$ (390 °F)
- S2** Bearing rings heat stabilized for operating temperatures $\leq 250\text{ °C}$ (480 °F)
- S3** Bearing rings heat stabilized for operating temperatures $\leq 300\text{ °C}$ (570 °F)

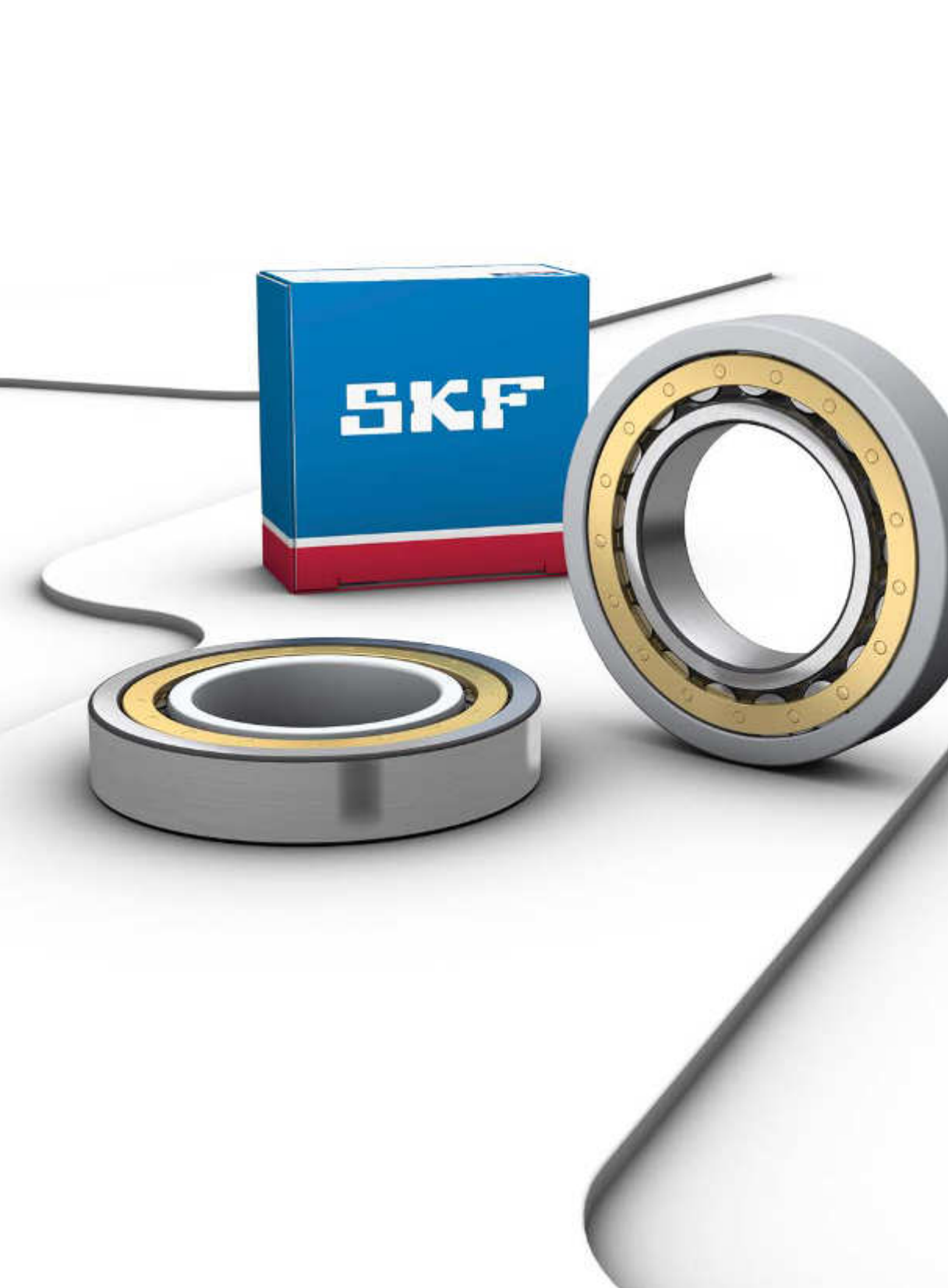

SKF

15E INSOCOAT bearings

Designs and variants	1206
INSOCOAT bearings with a coated outer ring	1207
INSOCOAT bearings with a coated inner ring	1207
Cages.	1208
Sealing solutions	1208

Bearing data	1209
(Dimension standards, tolerances, internal clearance, misalignment, friction, starting torque, power loss, defect frequencies, electrical properties)	

Loads	1210
(Minimum load, axial load carrying capacity, equivalent loads)	

Temperature limits	1210
-------------------------------------	-------------

Permissible speed	1210
------------------------------------	-------------

Design of bearing arrangements	1210
Abutment dimensions	1210
Mounting.	1210

Designation system	1211
-------------------------------------	-------------

Product tables

15E.1 INSOCOAT deep groove ball bearings.	1212
15E.2 INSOCOAT cylindrical roller bearings	1214

15E INSOCOAT bearings

Electric motors, generators and associated equipment are at risk when an electric current passes through a bearing. This can damage the contact surfaces of rolling elements and raceways in the bearing (electrical erosion) and rapidly degrade the grease. An additional risk in electric motors and generators comes from high frequency currents due to the inherent stray capacitance. The risk of damage increases if the application uses a frequency converter.

INSOCOAT bearings (→ **fig. 1**) are designed to prevent current from passing through the bearing. The bearings are a very cost-effective solution compared with other insulation methods. By integrating the insulating properties into the bearing, INSOCOAT bearings can improve reliability and increase machine uptime by virtually eliminating the problem of electrical erosion.

Designs and variants

An INSOCOAT bearing is a standard bearing that has the external surfaces of its inner or outer ring plasma-sprayed with an aluminium oxide to form a coating. The coating is sealed



with a resin to protect against the conductive effects of water and moisture.

The basic coating can withstand voltages up to 1 000 V DC. However, coatings to withstand voltages up to 2 000, or even 3 000 V DC, can be supplied on request.

The standard assortment of INSOCOAT bearings listed in this catalogue constitutes the most commonly used sizes and variants of:

- single row deep groove ball bearings
- single row cylindrical roller bearings

Matrix 1 provides an overview of the standard assortment. For bearing types and sizes other than those listed, contact the SKF application engineering service.

For applications where smaller bearings than those listed are needed, SKF recommends using SKF hybrid bearings (→ *Hybrid bearings*, **page 1219**).

More information

Bearing life and load ratings	63
Design considerations	159
Bearing systems	160
Recommended fits	169
Abutment and fillet dimensions	208
Lubrication	239
Mounting, dismantling and bearing care	271
Mounting instructions for individual bearings	→ skf.com/mount

INSOCOAT bearings with a coated outer ring

INSOCOAT bearings typically have the external surfaces of the outer ring coated with aluminium oxide. These bearings are identified by the designation suffix VL0241.

INSOCOAT bearings with a coated inner ring

INSOCOAT bearings that have the external surfaces of the inner ring coated are identified by the designation suffix VL2071. These bearings provide enhanced protection against high frequency electric currents due to the smaller coated surface area of the inner ring compared to the outer ring.

Matrix 1

INSOCOAT bearings – standard assortment

Bore diameter [mm]	Deep groove ball bearings				Cylindrical roller bearings				Bearing size	
	62../C3VL0241	62../C3VL2071	63../C3VL0241	63../C3VL2071	NU 10../C3VL0241	NU 10../C3VL2071	NU 2../C3VL0241	NU 2../C3VL2071		NU 3../C3VL0241
50										10
55										11
60										12
65										13
70										14
75										15
80										16
85										17
90										18
95										19
100										20
110										22
120										24
130										26
140										28
150										30

15E INSOCOAT bearings

Cages

INSOCOAT bearings are fitted with one of the following cages:

- for deep groove ball bearings
 - a stamped steel cage, riveted, ball centred (no designation suffix)
- for cylindrical roller bearings
 - a glass fibre reinforced PA66 cage, window-type, roller centred (designation suffix P)
 - a machined brass cage, riveted, roller centred (designation suffix M)
 - a machined brass cage, window-type, inner or outer ring centred, depending on the bearing design (designation suffix ML)

For additional information about cages, refer to *Cages* in the relevant product chapter (→ **page 298** for deep groove ball bearings and **page 582** for cylindrical roller bearings).

The lubricants generally used for rolling bearings do not have a detrimental effect on cage properties. However, some synthetic oils and greases with a synthetic oil base and lubricants containing a high proportion of EP additives, when used at high temperatures, can have a detrimental effect on polyamide cages. For additional information about the suitability of cages, refer to *Cages* (→ **page 37**) and *Cage materials* (→ **page 152**).

Sealing solutions

Some INSOCOAT deep groove ball bearings can be supplied capped. For selection advice, contact the SKF application engineering service.

Bearing data

	Deep groove ball bearings	Cylindrical roller bearings
Dimension standards	Boundary dimensions: ISO 15	
Tolerances	Normal Higher accuracy (up to P5) for some bearings on request	Normal
For additional information (→ page 132)	Values: ISO 492 (→ tables 3 to 5, pages 137 to 139) The aluminium-oxide layer on the external surfaces of either the inner or the outer ring does not affect accuracy.	
Internal clearance	C3	C3 Check availability of other clearance classes
For additional information (→ page 149)	Values: ISO 5753-1 (→ table 6, page 314)	Values: ISO 5753-1 (→ table 3, page 590)
	Values are valid for unmounted bearings under zero measuring load.	
Misalignment	Identical to standard bearings (→ page 312)	Identical to standard bearings (→ page 585)
Friction, starting torque, power loss	Frictional moment, starting torque and power loss can be calculated as specified under <i>Friction</i> (→ page 97), or using the tools available online at skf.com/bearingcalculator .	
Defect frequencies	Defect frequencies can be calculated using the tools available online at skf.com/bearingcalculator .	
Electrical properties	The standard INSOCOAT layer provides protection against AC and DC currents. The minimum ohmic resistance is 50 MΩ at 1 000 V DC. Tests at SKF have shown that electrical breakdown of the insulating layer occurs above 3 000 V DC.	

Loads

Minimum load, axial load carrying capacity, equivalent dynamic bearing load, equivalent static bearing load

For load recommendations, refer to *Loads* in the relevant product chapter (→ **page 316** for deep groove ball bearings and **page 594** for cylindrical roller bearings).

Temperature limits

Refer to *Temperature limits* in the relevant product chapter (→ **page 318** for deep groove ball bearings and **page 599** for cylindrical roller bearings).

Permissible speed

Refer to *Permissible speed* in the relevant product chapter (→ **page 318** for deep groove ball bearings and **page 600** for cylindrical roller bearings).

Design of bearing arrangements

Abutment dimensions

To maximize the effectiveness of the insulation, SKF recommends the following guidelines for dimensioning the shaft and housing shoulders (→ **fig. 2**). For bearings with a coated outer ring (designation suffix VL0241), the abutment diameter in the housing should be $\geq D_{a\ min}$ (→ **product tables**). For bearings with a coated inner ring (designation suffix VL2071), the abutment diameter on the shaft should be $\leq d_{a\ max}$ (→ **product tables**).

Mounting

During mounting, INSOCOAT bearings should be handled in the same way as standard bearings. When using an induction heater, the INSOCOAT layer must not be damaged by the vibration of the heater. For bearings with a coated inner ring (designation suffix VL2071), use a protective sleeve or an additional support block made of plastic.

In cases where springs are used to apply preload or lock nuts are used for axial clamping, SKF recommends inserting a steel spacer ring between the bearing and the preload or locking device (→ **fig. 3**).

Fig. 2

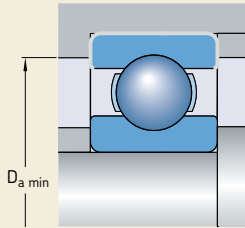

Coated outer ring

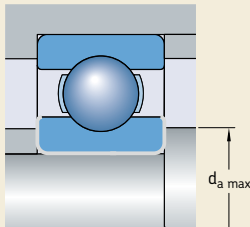

Coated inner ring

Fig. 3

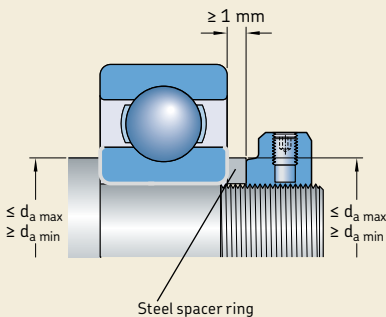

Steel spacer ring

Designation system

Refer to *Designation system* in the relevant product chapter (→ **page 320** for deep groove ball bearings and **page 602** for cylindrical roller bearings).

The designation suffixes used to identify INSOCOAT bearings are explained in the following.

- VL0241** External surfaces of the outer ring are coated
- VL2071** External surfaces of the inner ring are coated

15E.1 INSOCOAT deep groove ball bearings d 70 – 150 mm

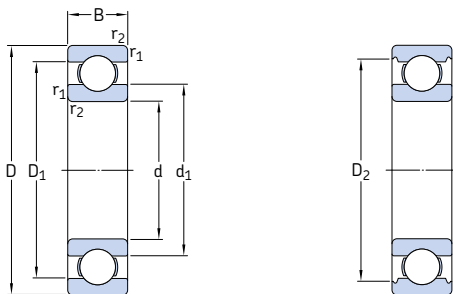

Principal dimensions			Basic load ratings		Fatigue load limit	Speed ratings		Mass	Designation
d	D	B	dynamic	static		Reference speed	Limiting speed		
mm			C	C ₀	P _u	r/min		kg	–
70	150	35	111	68	2,75	9 500	6 300	2,5	6314/C3VL0241
75	130	25	68,9	49	2,04	10 000	6 700	1,2	6215/C3VL0241
	160	37	119	76,5	3	9 000	5 600	3,05	6315/C3VL0241
80	140	26	72,8	55	2,2	9 500	6 000	1,4	6216/C3VL0241
	170	39	130	86,5	3,25	8 500	5 300	3,55	6316/C3VL0241
85	150	28	87,1	64	2,5	9 000	5 600	1,75	6217/C3VL0241
	180	41	140	96,5	3,55	8 000	5 000	4,1	6317/C3VL0241
90	160	30	101	73,5	2,8	8 500	5 300	2,4	6218/C3VL0241
	190	43	151	108	3,8	7 500	4 800	4,9	6318/C3VL0241
95	170	32	114	81,5	3	8 000	5 000	2,5	6219/C3VL0241
	200	45	159	118	4,15	7 000	4 500	5,65	6319/C3VL0241
100	180	34	127	93	3,35	7 500	4 800	3,15	6220/C3VL0241
	215	47	174	140	4,75	6 700	4 300	7	6320/C3VL0241
110	200	38	151	118	4	6 700	4 300	4,25	6222/C3VL0241
	240	50	203	180	5,7	6 000	3 800	9,65	6322/C3VL0241
120	215	40	146	118	3,9	6 300	4 000	5,2	6224/C3VL0241
	260	55	208	186	5,7	5 600	3 400	12,5	6324/C3VL2071
130	230	40	156	132	4,15	5 600	3 600	5,75	6226/C3VL2071
	280	58	229	216	6,3	5 000	3 200	15	6326/C3VL2071
140	300	62	251	245	7,1	4 800	4 300	18,5	6328/C3VL2071
150	270	45	174	166	4,9	5 000	3 200	9,8	6230/C3VL2071
	320	65	276	285	7,8	4 300	2 800	23	6330/C3VL2071

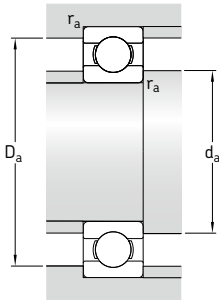

Dimensions					Abutment and fillet dimensions					Calculation factors	
d	d ₁	D ₁	D ₂	r _{1,2} min.	d _a min.	d _a max.	D _a min.	D _a max.	r _a max.	k _r	f _g
mm											
70	94,9	125	132	2,1	82	–	136	138	2	0,03	13
75	92	113	118	1,5	84	–	121	121	1,5	0,03	15
	101	134	141	2,1	87	–	146	148	2	0,03	13
80	101	123	122	2	91	–	128	129	2	0,025	15
	108	142	149	2,1	92	–	154	158	2	0,03	13
85	106	130	134	2	96	–	139	139	2	0,025	15
	114	151	158	3	99	–	163	166	2,5	0,03	13
90	112	138	145	2	101	–	149	149	2	0,025	15
	121	159	166	3	104	–	171	176	2,5	0,03	13
95	118	147	151	2,1	107	–	156	158	2	0,025	14
	127	168	174	3	109	–	179	186	2,5	0,03	13
100	124	155	160	2,1	112	–	165	168	2	0,025	14
	135	180	186	3	114	–	191	201	2,5	0,03	13
110	138	172	179	2,1	122	–	184	188	2	0,025	14
	149	200	207	3	124	–	213	226	2,5	0,03	13
120	150	185	189	2,1	132	–	194	203	2	0,025	14
	164	215	–	3	134	158	–	246	2,5	0,03	14
130	160	198	–	3	144	154	–	216	2,5	0,025	15
	177	232	–	4	147	171	–	263	3	0,03	14
140	190	249	–	4	157	185	–	283	3	0,03	14
150	190	228	–	3	164	185	–	256	2,5	0,025	15
	205	264	–	4	167	200	–	303	3	0,03	14

15E.2 INSOCOAT cylindrical roller bearings

d 50 – 95 mm

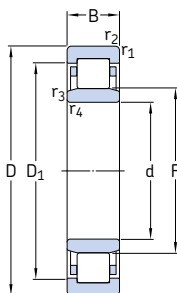

Principal dimensions			Basic load ratings		Fatigue load limit	Speed ratings		Mass	Designation
d	D	B	dynamic	static		Reference speed	Limiting speed		
mm			kN		kN	r/min		kg	–
50	80	16	47,3	57	7,2	9 500	9 500	0,27	NU 1010 ECP/C3VL0241
	90	20	66	72	9,15	7 500	9 000	0,48	NU 210 ECM/C3VL0241
	110	27	112	116	15,3	6 000	8 000	1,36	NU 310 ECM/C3VL0241
55	90	18	57,2	69,5	9	8 500	13 000	0,45	NU 1011 ECML/C3VL0241
	100	21	85,8	100	12,9	7 000	8 000	0,78	NU 211 ECM/C3VL0241
	120	29	138	146	19	5 600	7 000	1,73	NU 311 ECM/C3VL0241
60	95	18	38	45,5	5,85	8 000	13 000	0,48	NU 1012 ML/C3VL0241
	110	22	96,8	106	14	6 300	7 500	0,97	NU 212 ECM/C3VL0241
	130	31	154	163	21,2	5 000	6 700	2,16	NU 312 ECM/C3VL0241
65	100	18	62,7	81,5	10,6	7 500	7 500	0,45	NU 1013 ECP/C3VL0241
	120	23	110	122	16	5 600	6 700	1,23	NU 213 ECM/C3VL0241
	140	33	183	196	25,5	4 800	6 000	2,63	NU 313 ECM/C3VL0241
70	110	20	79,2	98	12,9	7 000	7 000	0,62	NU 1014 ECP/C3VL0241
	125	24	121	140	18,6	5 300	6 300	1,37	NU 214 ECM/C3VL0241
	150	35	209	228	29	4 300	5 600	3,12	NU 314 ECM/C3VL0241
75	115	20	58,3	71	9,3	6 700	6 700	0,75	NU 1015 M/C3VL0241
	130	25	132	160	21,2	5 300	6 000	1,48	NU 215 ECM/C3VL0241
	160	37	242	270	34	4 000	5 300	3,9	NU 315 ECP/VL0241
	160	37	242	270	34	4 000	5 300	3,9	NU 315 ECM/C3VL0241
80	125	22	67,1	83	10,6	6 300	6 300	1	NU 1016/C3VL0241
	140	26	142	173	22	4 800	5 600	1,84	NU 216 ECM/C3VL0241
	170	39	264	290	36	3 800	5 000	4,61	NU 316 ECM/C3VL0241
85	130	22	72,1	91,5	11,6	6 000	6 000	1,1	NU 1017 M/C3VL0241
	150	28	168	200	25,5	4 500	5 300	2,25	NU 217 ECM/C3VL0241
	180	41	297	340	41,5	3 600	4 800	5,32	NU 317 ECM/C3VL0241
90	140	24	85,8	110	13,7	5 600	5 600	1,35	NU 1018 M/C3VL0241
	160	30	187	224	28	4 300	5 000	2,75	NU 218 ECM/C3VL0241
	190	43	319	360	44	3 400	4 500	6,26	NU 318 ECM/C3VL0241
95	145	24	88	116	14,3	5 300	5 300	1,4	NU 1019 ML/C3VL0241
	170	32	224	270	33,5	4 000	4 800	2,84	NU 219 ECM/C3VL0241
	200	45	341	390	46,5	3 200	4 300	7,25	NU 319 ECM/C3VL0241

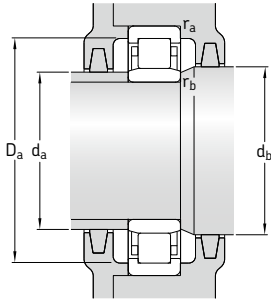

Dimensions						Abutment and fillet dimensions						Calculation factors	
d	D ₁	F	r _{1,2} min.	r _{3,4} min.	s ¹⁾	d _a min.	d _a max.	d _b min.	D _a min.	D _a max.	r _a max.	r _b max.	k _r
mm													
50	70	57,5	1	0,6	1	53,2	56	60	74	75,4	1	0,6	0,1
	78	59,5	1,1	1,1	1,5	57	57	62	83	83	1	1	0,15
	92,1	65	2	2	1,9	61	63	67	95,1	99	2	2	0,15
55	79	64,5	1,1	1	0,5	59,6	63	67	80	84	1	1	0,1
	86,3	66	1,5	1,1	1	62	64	68	91	91	1,5	1	0,15
	101	70,5	2	2	2	66	68	73	106	109	2	2	0,15
60	81,6	69,5	1,1	1	2,9	64,6	68	72	85	89	1	1	0,1
	95,7	72	1,5	1,5	1,4	69	70	74	100,65	101	1,5	1,5	0,15
	110	77	2	2,1	2,1	72	74	79	114,5	118	2	2	0,15
65	88,5	74	1,1	1	1	69,6	72	77	89,6	94	1	1	0,1
	104	78,5	1,5	1,5	1,4	74	76	81	109	111	1,5	1,5	0,15
	119	82,5	2,1	2,1	2,2	77	80	85	122,5	128	2	2	0,15
70	97,5	79,5	1,1	1	1,3	74,6	78	82	101	104	1	1	0,1
	109	83,5	1,5	1,5	1,2	79	81	86	115	116	1,5	1,5	0,15
	127	89	2,1	2,1	1,8	82	86	91	130,6	138	2	2	0,15
75	101	85	1,1	1	3	79,6	83	87	105,5	109	1	1	0,1
	114	88,5	1,5	1,5	1,2	84	86	91	118,45	121	1,5	1,5	0,15
	136	95	2,1	2,1	1,8	87	92	97	141	148	2	2	0,15
	136	95	2,1	2,1	1,8	87	92	97	141	148	2	2	0,15
80	109	91,5	1,1	1	3,3	86	90	94	114	119	1	1	0,1
	123	95,3	2	2	1,4	91	93	98	127,4	129	2	2	0,15
	144	101	2,1	2,1	2,1	92	98	104	148,5	158	2	2	0,15
85	114	96,5	1,1	1	3,3	89,6	95	99	119	124	1	1	0,1
	131	100,5	2	2	1,5	96	98	103	136	139	2	2	0,15
	153	108	3	3	2,3	99	105	111	158	166	2,5	2,5	0,15
90	122	103	1,5	1,1	3,5	96	101	106	127,1	133	1,5	1	0,1
	140	107	2	2	1,8	101	104	110	144	149	2	2	0,15
	162	113,5	3	3	2,5	104	110	116	166,1	176	2,5	2,5	0,15
95	127	108	1,5	1,1	3,5	101	106	111	132,1	138	1,5	1	0,1
	149	112,5	2,1	2,1	1,7	107	110	115	153,15	158	2	2	0,15
	170	121,5	3	3	2,9	109	118	124	175	186	2,5	2,5	0,15

¹⁾ Permissible axial displacement from the normal position of one bearing ring relative to the other.

15E.2 INSOCOAT cylindrical roller bearings

d 100 – 150 mm

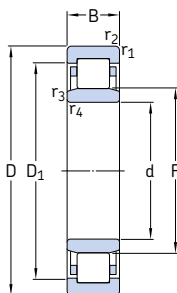

Principal dimensions			Basic load ratings		Fatigue load limit	Speed ratings		Mass	Designation
d	D	B	dynamic	static		Reference speed	Limiting speed		
mm			kN		kN	r/min		kg	-
100	150	24	89,7	122	15	5 000	5 000	1,45	NU 1020 M/C3VL0241
	180	34	251	310	38	3 800	4 500	4,02	NU 220 ECM/C3VL0241
	215	47	391	440	51	3 000	3 800	8,65	NU 320 ECM/C3VL0241
110	150	28	130	173	20,8	4 500	4 500	2,3	NU 1022 M/C3VL0241
	200	38	297	375	44	3 400	4 000	5,62	NU 222 ECM/C3VL0241
	240	50	468	540	61	2 600	3 400	11,99	NU 322 ECM/C3VL0241
120	180	28	138	190	22,4	4 000	4 000	2,55	NU 1024 M/C3VL2071
	215	40	341	440	50	3 000	3 600	6,63	NU 224 ECM/C3VL0241
	260	55	539	620	69,5	2 400	3 200	14,94	NU 324 ECM/C3VL0241
130	200	33	168	232	27	3 800	5 600	3,85	NU 1026 ML/C3VL2071
	230	40	369	465	52	2 800	3 400	7,62	NU 226 ECM/C3VL2071
	280	58	627	750	81,5	2 200	3 000	18,3	NU 326 ECM/C3VL2071
140	210	33	179	255	29	3 600	3 600	4,05	NU 1028 M/C3VL2071
	250	42	396	520	58,5	2 600	3 200	9	NU 228 ECM/C3VL2071
	300	62	682	830	88	2 200	2 800	25,12	NU 328 ECM/C3VL2071
150	225	35	205	300	33,5	3 200	5 000	4,9	NU 1030 ML/C3VL2071
	270	45	457	610	65,5	2 400	2 800	11,8	NU 230 ECM/C3VL2071
	320	65	765	950	100	2 000	2 600	31,06	NU 330 ECM/C3VL2071

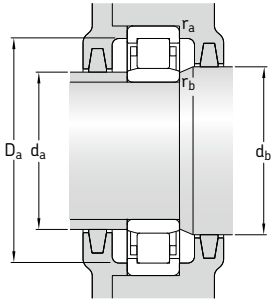

Dimensions						Abutment and fillet dimensions								Calculation factors
d	D ₁	F	r _{1,2} min.	r _{3,4} min.	s ¹⁾	d _a min.	d _a max.	d _b min.	D _a min.	D _a max.	r _a max.	r _b max.	k _r	
mm						mm								-
100	132	113	1,5	1,1	3,5	106	111	116	137,5	143	1,5	1	0,1	
	157	119	2,1	2,1	1,7	112	116	122	161,5	168	2	2	0,15	
	182	127,5	3	3	2,9	114	124	130	192	201	2,5	2,5	0,15	
110	149	125	2	1,1	3,8	116	123	128	154,7	161	2	1	0,1	
	174	132,5	2,1	2,1	2,1	122	130	135	178,3	188	2	2	0,15	
	201	143	3	3	3	124	139	146	207	226	2,5	2,5	0,15	
120	159	135	2	1,1	3,8	126	133	138	127	171	2	1	0,1	
	188	143,5	2,1	2,1	1,9	132	140	146	193	203	2	2	0,15	
	219	154	3	3	3,7	134	150	157	225	246	2,5	2,5	0,15	
130	175	148	2	1,1	4,7	136	145	151	139	191	2	1	0,1	
	202	153,5	3	3	2,1	144	145	156	-	216	2,5	2,5	0,15	
	236	167	4	3	3,7	147	156	170	-	263	3	3	0,15	
140	185	158	2	1,1	4,4	146	155	161	-	201	2	1	0,1	
	217	169	3	3	2,5	154	160	172	-	236	2,5	2,5	0,15	
	252	180	4	3	3,7	157	168	183	-	283	3	3	0,15	
150	198	169,5	2,1	1,5	4,9	157	167	173	-	215	2	1,5	0,1	
	234	182	3	3	2,5	163	172	185	-	256	2,5	2,5	0,15	
	270	193	4	3	4	167	182	196	-	303	3	3	0,15	

¹⁾ Permissible axial displacement from the normal position of one bearing ring relative to the other.



15F Hybrid bearings

Designs and variants	1220
Hybrid deep groove ball bearings	1223
Basic design bearings.	1223
Sealing solutions.	1223
XL hybrid bearings	1223
Hybrid cylindrical roller bearings.	1224
Cages.	1225
Hybrid bearings with special steel rings and coatings	1225
Bearing data	1226
(Dimension standards, tolerances, internal clearance, misalignment, axial displacement, defect frequencies, silicon nitride properties, electrical properties)	
Loads	1227
(Minimum load, axial preload, axial load carrying capacity, equivalent loads)	
Temperature limits.	1228
Permissible speed.	1228
Designation system	1228

Product tables

15F.1 Hybrid deep groove ball bearings.	1230
15F.2 Sealed hybrid deep groove ball bearings.	1232
15F.3 XL hybrid deep groove ball bearings.	1236
15F.4 Hybrid cylindrical roller bearings	1238

Other hybrid bearings

Hybrid super-precision angular contact ball bearings	→ skf.com/super-precision
Hybrid super-precision cylindrical roller bearings	→ skf.com/super-precision
Hybrid super-precision angular contact thrust ball bearings, single and double direction	→ skf.com/super-precision
Hybrid angular contact ball bearings	→ contact SKF
Hybrid bearing units	→ contact SKF

Designs and variants

Hybrid bearings have rings made of bearing steel and rolling elements made of bearing grade silicon nitride (Si_3N_4). Because the silicon nitride ceramic material is such an excellent electrical insulator, hybrid bearings can be used to effectively insulate the housing from the shaft in both AC and DC motors as well as in generators.

In addition to being an excellent insulator, hybrid bearings have higher speed capabilities and provide longer bearing service life under the same operating conditions than same-sized bearings with steel rolling elements. Hybrid bearings also perform extremely well under vibrating or oscillating conditions. Often, it is not necessary to preload the bearing or apply a special grease under these conditions.

Factors that influence SKF hybrid bearing performance

Bearing performance is not only determined by load or speed ratings. There are a number of other factors that contribute to bearing performance. Main factors that enhance SKF hybrid bearing performance, when compared

to same-sized bearings with steel rolling elements, include:

- **Insulating properties**

As a non-conductive material, silicon nitride protects the rings from electric current damage and, therefore, can extend bearing service life in applications like AC and DC motors and generators, where there are electric currents that could damage the bearing.

- **Lower density**

The density of a bearing grade silicon nitride rolling element is 60% lower than a same-sized rolling element made of bearing steel. Lower weight means lower inertia – and that translates into superior behaviour during rapid starts and stops, as well as higher speed capabilities.

- **Lower friction**

The lower density of a silicon nitride rolling element, combined with its low coefficient of friction, significantly reduces bearing temperature at high speeds. Cooler running extends the service life of both the bearing and the lubricant.

- **High hardness and high modulus of elasticity**

The high degree of hardness of a silicon nitride rolling element means high wear-resistance, increased bearing stiffness and longer bearing service life in contaminated environments.

- **Resists false brinelling**

If a stationary bearing is subjected to vibrations, there is a risk that “false brinelling” occurs. False brinelling is the formation of shallow depressions in the raceways that eventually lead to spalling and premature bearing failure. In cases where steel rolling elements were replaced by ceramic rolling elements, the bearings were found to be significantly less susceptible to false brinelling.

Hybrid bearings lubricated with SKF wide temperature grease (WT) were found to sustain less false brinelling damage than hybrid bearings lubricated with other types of greases.

More information

Bearing life and load ratings 63

Design considerations 159

Bearing systems 160

Recommended fits 169

Abutment and fillet dimensions 208

Lubrication 239

Mounting, dismantling and bearing care 271

Mounting instructions for individual bearings → skf.com/mount

- **Reduced risk of smearing between silicon nitride and steel surfaces**

Even under inadequate lubrication conditions, there is reduced risk of smearing between silicon nitride and steel surfaces. This enables hybrid bearings to operate much longer in applications where there are high speeds and fast accelerations, or applications where there is an insufficient hydrodynamic film to support undisturbed bearing operation (i.e. $\kappa < 1$, → *Selecting bearing size*, **page 61**). For conditions where $\kappa < 1$, it is common to apply $\kappa = 1$ for hybrid bearings for bearing life calculations. Hybrid bearings may perform well when lubricated with ultra-thin film forming media, such as refrigerants, typically used in compressor applications or fuel pumps, enabling oil-free designs.

- **Runs faster, lasts longer**

Combine the lower density of silicon nitride with its lower coefficient of friction, high hardness and the fact that silicon nitride does not smear the raceways under poor lubrication conditions, and the result is a bearing that runs faster and longer even under the most difficult operating conditions.

- **Low coefficient of thermal expansion**

A silicon nitride rolling element has a lower coefficient of thermal expansion than a same-sized rolling element made of bearing steel. This means less sensitivity to temperature gradients within the bearing and more accurate preload/clearance control.

When designing bearing arrangements for very low temperatures, a hybrid bearing with greater internal clearance than standard may need to be selected. In these cases, contact the SKF application engineering service.

- **Speed capability**

Typically, hybrid bearings have a higher speed capability than same-sized bearings with steel rolling elements, however, in some cases, the cage execution may limit the attainable speed.

15F Hybrid bearings

Assortment

The assortment of SKF hybrid bearings listed in this catalogue comprises popular sizes for electric motors and generators (→ **matrix 1**). It includes:

- single row deep groove ball bearings
 - basic design
 - sealed design
 - XL hybrid design
- single row cylindrical roller bearings

Hybrid bearings listed in this catalogue constitute the basic SKF assortment and are only part of the total assortment. Other hybrid bearings include:

- Hybrid super-precision bearings (→ skf.com/super-precision)
 - hybrid super-precision angular contact ball bearings
 - hybrid super-precision cylindrical roller bearings
 - hybrid super-precision angular contact thrust ball bearings, single and double direction
- Hybrid angular contact ball bearings
- Hybrid stainless steel deep groove ball bearings
- Bearing units incorporating hybrid bearings

For availability and detailed information, contact the SKF application engineering service.

Matrix 1

Hybrid bearings – standard assortment

Bore diameter [mm]	Deep groove ball bearings			Cylindrical roller bearings			Bearing size
	60../HC5C3	62../HC5C3	63../HC5C3	NU 10../HC5C3	NU 2../HC5C3	NU 3../HC5C3	
5							/5
6							/6
7							/7
8							/8
10							00
12							01
15							02
17							03
20							04
25							05
30							06
35							07
40							08
45							09
50							10
55							11
60							12
65							13
70							14
75							15
80							16
85							17
90							18
95							19
100							20
110							22
120							24
130							26
140							28
150							30
160							32
170							34
180							36

 Sealed design

 Basic design

 XL hybrid design (VA970)

Hybrid deep groove ball bearings

Deep groove ball bearings are the most widely used bearing type, especially in electric motors. These non-separable bearings are suitable for high speeds. The deep uninterrupted raceway grooves have a close osculation with the balls, enabling the bearings to accommodate radial loads and axial loads in both directions.

SKF hybrid deep groove ball bearings are available with a bore diameter ranging from 5 to 180 mm. They are manufactured to SKF Explorer performance class quality.

Bearings with a bore diameter $d \leq 45$ mm are most suitable for electric motors in the power range of 0,15 up to 15 kW as well as power tools and high-speed drives. SKF hybrid deep groove ball bearings in this size range are the most cost-effective solution against electrical erosion.

Basic design bearings

Basic design bearings are available with a bore diameter $d > 45$ mm (→ **fig. 1**). If a small quantity of smaller open design bearings is required, SKF recommends ordering sealed hybrid bearings and removing the seals.

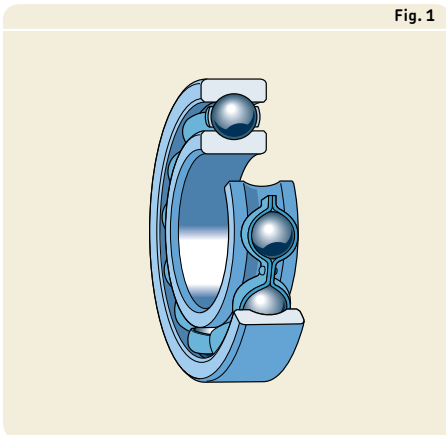

Fig. 1

Sealing solutions

Sealed hybrid deep groove ball bearings use the same seals as described in the relevant section of *Deep groove ball bearings* (→ **page 295**). They are lubricated for the life of the bearing and should not be washed or relubricated. The bearings are considered maintenance-free. If they are to be hot mounted, SKF recommends using an induction heater whenever possible. SKF does not recommend heating a sealed bearing above 80 °C (175 °F).

Greases for sealed bearings

Sealed hybrid deep groove ball bearings are filled with a high-quality grease under clean conditions. The standard grease, suitable for the most common operating conditions of electric motors and generators, is indicated by the designation suffix WT. Grease specifications are listed in **table 4** (→ **page 305**), under grease "WT".

For additional information about greases, refer to *Lubrication* (→ **page 239**).

Grease life

For SKF hybrid deep groove ball bearings, the estimated grease life can be assumed to be at least twice as long as for same-sized bearings with steel balls (→ *Grease life for capped bearings*, **page 306**). Conditions such as the presence of water or other fluids or vibration can reduce the grease life.

XL hybrid bearings

XL hybrid deep groove ball bearings (designation suffix VA970) are designed to meet the application requirements for electric generators in larger wind turbines. SKF supplies XL hybrid deep groove ball bearings for the most commonly used generator sizes (→ **product table**).

WARNING

Seals made of FKM (fluoro rubber) exposed to an open flame or temperatures above 300 °C (570 °F) are a health and environmental hazard! They remain dangerous even after they have cooled.

Read and follow the safety precautions under *Seal materials* (→ **page 155**).

15F Hybrid bearings

Hybrid cylindrical roller bearings

Hybrid cylindrical roller bearings are commonly used in electric motors, especially traction motors, and in applications running under severe operating conditions. They can accommodate heavy radial loads and high speeds.

The NU design cylindrical roller bearing, which has two integral flanges on the outer ring and no flanges on the inner ring, is the standard variant for hybrid cylindrical roller bearings (→ **fig. 2**).

Fig. 2

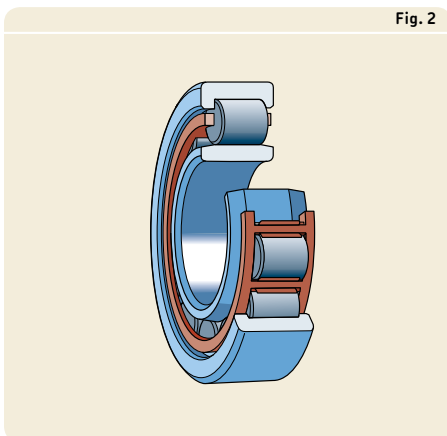

Cages

Depending on their size, SKF hybrid deep groove ball bearings are fitted with one of the following cages:

- a stamped steel cage, riveted, ball centred (no designation suffix)
- a glass fibre reinforced PA66 cage, snap-type, ball centred (designation suffix TN9)
- a glass fibre reinforced PEEK cage, snap-type, ball centred (designation suffix TNH)

Depending on their series and size, SKF hybrid cylindrical roller bearings are fitted with one of the following cages:

- a glass fibre reinforced PA66 cage, window-type, roller centred (designation suffix P)
- a glass fibre reinforced PEEK cage, window-type, roller centred (designation suffix PH)
- a machined brass cage, riveted, roller centred (designation suffix M)
- a machined brass cage, window-type, inner or outer ring centred, depending on the bearing design (designation suffix ML)

For additional information about cages, refer to *Cages* in the relevant product chapter (→ **page 298** for deep groove ball bearings and **page 582** for cylindrical roller bearings).

The lubricants generally used for rolling bearings do not have a detrimental effect on cage properties. However, some synthetic oils and greases with a synthetic oil base and lubricants containing a high proportion of EP additives, when used at high temperatures, can have a detrimental effect on polyamide cages. For additional information about the suitability of cages, refer to *Cages* (→ **page 37**) and *Cage materials* (→ **page 152**).

Hybrid bearings with special steel rings and coatings

Hybrid bearings can be customized for specific application requirements. For additional information about the following variants, contact the SKF application engineering service.

- bearing rings stabilized for temperatures $\leq 300\text{ °C}$ (570 °F)
- bearing rings made of through-hardened stainless steel for enhanced corrosion and wear-resistance and with good high-temperature properties
- bearing rings made of through-hardened stainless steel for cryogenic temperatures
- bearing rings made of high-temperature tool steel
- coating with zinc chromate or thin dense chromium for corrosion protection
- coating based on molybdenum for low friction, especially in vacuum or gas applications

Bearing data

	Deep groove ball bearings	Cylindrical roller bearings
Dimension standards	Boundary dimensions: ISO 15	
Tolerances	Normal	Normal P6 running accuracy
For additional information (→ page 132)	Values: ISO 492 (→ tables 3 and 4, pages 137 and 138)	
Internal clearance	C3 Check availability of other clearance classes	
For additional information (→ page 149)	Values: ISO 5753-1 (→ table 6, page 314)	Values: ISO 5753-1 (→ table 3, page 590)
	Values are valid for unmounted bearings under zero measuring load.	
Misalignment	Identical to standard bearings (→ page 312)	Identical to standard bearings (→ page 585)
Axial displacement	–	NU design hybrid cylindrical roller bearings can accommodate axial displacement of the shaft relative to the housing within the bearing. Values for the permissible axial displacement s from the normal position of one bearing ring relative to the other are listed in the product tables.
Defect frequencies	Defect frequencies can be calculated using the tools available online at skf.com/bearingcalculator .	
Silicon nitride properties	For bearing grade silicon nitride (Si_3N_4), refer to <i>Materials for rolling bearings</i> (→ page 150).	
Electrical properties	Hybrid bearings provide protection against AC and DC currents. The impedance for a hybrid bearing is high, even for very high frequencies, providing good protection against high frequency current and voltage peaks. For small hybrid deep groove ball bearings fitted with a contact NBR seal, the voltage level before the first arcing occurs through the seal/bearing contact is > 2,5 kV DC. For additional information, contact the SKF application engineering service.	

Loads

	Deep groove ball bearings	Cylindrical roller bearings
Minimum load	Refer to <i>Minimum load</i> (→ page 316) of standard bearings.	Refer to <i>Minimum load</i> (→ page 594) of standard bearings.
	When compared to a bearing with steel rolling elements, hybrid bearings are less sensitive to skidding and smearing damage that occurs in lightly loaded applications, even if light loads are only a small part of a variable load cycle.	
Axial preload For additional information (→ page 214)	To provide low noise and high-speed operation, typically an axial preload to a bearing arrangement comprising two hybrid deep groove ball bearings is applied. Axial preload can be applied with spring washers, as described under <i>Pre-loading with springs</i> (→ page 224).	–
Axial load carrying capacity	Identical to standard bearings (→ page 316)	–
Equivalent bearing loads	Identical to standard bearings (→ page 316)	Identical to standard bearings (→ page 594)

Temperature limits

The permissible operating temperature for hybrid bearings can be limited by:

- the dimensional stability of the bearing rings
- the cage
- the seals
- the lubricant

When temperatures outside the permissible range are expected, contact the SKF application engineering service.

Bearing rings

The rings of SKF hybrid bearings undergo a special heat treatment. Depending on the bearing type and variant, hybrid bearings are heat stabilized up to:

- 120 °C (250 °F) for hybrid deep groove ball bearings
- 150 °C (300 °F) for hybrid cylindrical roller bearings and XL hybrid deep groove ball bearings

On request, SKF can supply hybrid bearings with rings stabilized for operating temperatures up to 300 °C (570 °F).

Cages

Steel, brass or PEEK cages can be used at the same operating temperatures as the bearing rings of standard hybrid bearings. For temperature limits of other polymer cages, refer to *Cage materials* (→ page 152).

Seals

The permissible operating temperature for seals depends on the material:

- NBR seals:
–40 to +100 °C (–40 to +210 °F)
Temperatures up to 120 °C (250 °F) can be tolerated for brief periods.
- FKM seals:
–30 to +230 °C (–20 to +445 °F)

Lubricants

Temperature limits for the grease used in sealed SKF hybrid deep groove ball bearings are provided under *Deep groove ball bearings*

(→ table 4, page 305). Temperature limits for other SKF greases are provided under *Lubrication* (→ page 239).

When using lubricants not supplied by SKF, the temperature limits should be evaluated according to the SKF traffic light concept (→ page 244).

Permissible speed

The permissible speed can be estimated using the speed ratings listed in the product tables and applying the information provided under *Speeds* (→ page 117). If no reference speed is listed in the product tables, the limiting speed is the permissible speed.

The values for the reference speed listed in the product tables for sealed deep groove ball bearings are valid for basic design bearings (i.e. seals removed from the bearings) and demonstrate the speed capability of these bearings.

Designation system

Refer to *Designation system* in the relevant product chapter (→ page 320 for deep groove ball bearings and page 602 for cylindrical roller bearings).

Additional designation suffixes used with SKF hybrid bearings are explained in the following.

HC5	Rolling elements made of silicon nitride
VA970	Special design for wind turbine generators
-2RSH2	Contact seal, FKM, on both sides
C3P	Displaced clearance range comprising the upper half of the C3 plus the lower half of the C4 clearance range
F1	Grease fill 10–15% of the free space in the bearing
S0	Bearing rings heat stabilized for operating temperatures ≤ 150 °C (300 °F)

15F.1 Hybrid deep groove ball bearings

d 50 – 100 mm

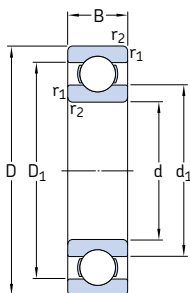

Principal dimensions			Basic load ratings		Fatigue load limit	Speed ratings		Mass	Designation
d	D	B	C	C ₀	P _u	Reference speed	Limiting speed	kg	–
mm			kN		kN	r/min		kg	–
50	90	20	37,1	23,2	0,98	20 000	12 000	0,45	6210/HC5C3
	110	27	65	38	1,6	18 000	10 000	1,1	6310/HC5C3
55	100	21	46,2	29	1,25	19 000	10 000	0,61	6211/HC5C3
	120	29	74,1	45	1,9	17 000	9 000	1,35	6311/HC5C3
60	110	22	55,3	36	1,53	17 000	9 500	0,78	6212/HC5C3
	130	31	85,2	52	2,2	15 000	8 500	1,7	6312/HC5C3
65	120	23	58,5	40,5	1,73	16 000	8 500	1	6213/HC5C3
	140	33	97,5	60	2,5	14 000	8 000	2,1	6313/HC5C3
70	125	24	63,7	45	1,9	15 000	8 500	1,1	6214/HC5C3
	150	35	111	68	2,75	13 000	7 500	2,55	6314/HC5C3
75	130	25	68,9	49	2,04	14 000	8 000	1,2	6215/HC5C3
	160	37	119	76,5	3	12 000	6 700	3,05	6315/HC5C3
80	140	26	72,8	55	2,2	13 000	7 000	1,45	6216/HC5C3
	170	39	130	86,5	3,25	12 000	6 300	3,65	6316/HC5C3
85	150	28	87,1	64	2,5	12 000	6 700	1,8	6217/HC5C3
	180	41	140	96,5	3,55	11 000	6 000	4,25	6317/HC5C3
90	160	30	101	73,5	2,8	12 000	6 300	2,2	6218/HC5C3
	190	43	151	108	3,8	10 000	5 600	4,95	6318/HC5C3
95	170	32	114	81,5	3	11 000	6 000	2,65	6219/HC5C3
	200	45	159	118	4,15	9 500	5 300	5,75	6319/HC5C3
100	180	34	127	93	3,35	10 000	5 600	3,17	6220/HC5C3
	215	47	174	140	4,75	9 000	5 000	7,1	6320/HC5C3

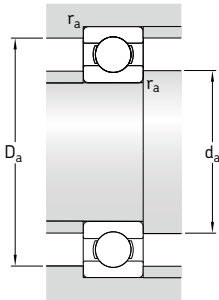

Dimensions				Abutment and fillet dimensions			Calculation factors	
d	d ₁ ~	D ₁ ~	r _{1,2} min.	d _a min.	D _a max.	r _a max.	k _r	f ₀
mm				mm			-	
50	62,5	77,4	1,1	57	83	1	0,025	14
	68,7	91,1	2	61	99	2	0,03	13
55	69	85,8	1,5	64	91	1,5	0,025	14
	75,3	99,5	2	66	109	2	0,03	13
60	75,5	94,6	1,5	69	101	1,5	0,025	14
	81,8	108	2,1	72	118	2	0,03	13
65	83,3	103	1,5	74	111	1,5	0,025	15
	88,3	117	2,1	77	128	2	0,03	13
70	87	108	1,5	79	116	1,5	0,025	15
	94,9	125	2,1	82	138	2	0,03	13
75	92	113	1,5	84	121	1,5	0,025	15
	101	134	2,1	87	148	2	0,03	13
80	101	123	2	91	129	2	0,025	15
	108	142	2,1	92	158	2	0,03	13
85	106	130	2	96	139	2	0,025	15
	114	151	3	99	166	2,5	0,03	13
90	112	138	2	101	149	2	0,025	15
	121	159	3	104	176	2,5	0,03	13
95	118	147	2,1	107	158	2	0,025	14
	127	168	3	109	186	2,5	0,03	13
100	124	155	2,1	112	168	2	0,025	14
	135	180	3	114	201	2,5	0,03	13

15F.2 Sealed hybrid deep groove ball bearings d 5 – 45 mm

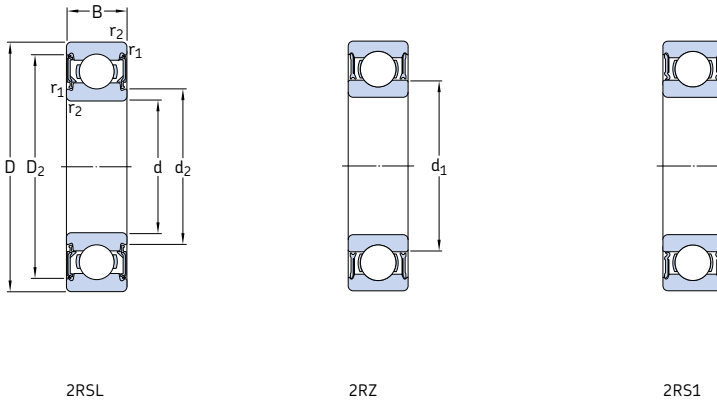

Principal dimensions			Basic load ratings		Fatigue load limit	Speed ratings		Mass	Designation
d	D	B	dynamic	static		Reference speed ¹⁾	Limiting speed		
mm			C	C ₀	P _u	r/min	kg	–	
5	16	5	1,14	0,38	0,016	130 000	70 000	0,005	625-2RZTN9/HC5C3WTF1
6	19	6	2,34	0,95	0,04	110 000	60 000	0,008	626-2RSLTN9/HC5C3WTF1
7	19	6	2,34	0,95	0,04	110 000	60 000	0,007	607-2RSLTN9/HC5C3WTF1
	22	7	3,45	1,37	0,057	95 000	53 000	0,012	627-2RSLTN9/HC5C3WTF1
8	22	7	3,45	1,37	0,057	95 000	53 000	0,01	608-2RSLTN9/HC5C3WTF1
10	26	8	4,75	1,96	0,083	85 000	45 000	0,018	6000-2RSLTN9/HC5C3WT
	30	9	5,4	2,36	0,1	75 000	43 000	0,032	6200-2RSLTN9/HC5C3WT
12	28	8	5,4	2,36	0,1	75 000	43 000	0,022	6001-2RSLTN9/HC5C3WT
	32	10	7,28	3,1	0,132	67 000	38 000	0,037	6201-2RSLTN9/HC5C3WT
15	32	9	5,85	2,85	0,12	63 000	36 000	0,03	6002-2RSLTN9/HC5C3WT
	35	11	8,06	3,75	0,16	60 000	32 000	0,044	6202-2RSLTN9/HC5C3WT
17	35	10	6,37	3,25	0,137	56 000	32 000	0,038	6003-2RSLTN9/HC5C3WT
	40	12	9,95	4,75	0,2	53 000	28 000	0,059	6203-2RSLTN9/HC5C3WT
20	42	12	9,95	5	0,212	48 000	26 000	0,062	6004-2RSLTN9/HC5C3WT
	47	14	13,5	6,55	0,28	45 000	24 000	0,097	6204-2RSLTN9/HC5C3WT
25	47	12	11,9	6,55	0,275	40 000	22 000	0,073	6005-2RSLTN9/HC5C3WT
	52	15	14,8	7,8	0,335	38 000	22 000	0,13	6205-2RSLTN9/HC5C3WT
30	55	13	13,8	8,3	0,355	34 000	19 000	0,11	6006-2RZTN9/HC5C3WT
	62	16	20,3	11,2	0,475	32 000	18 000	0,18	6206-2RZTN9/HC5C3WT
35	62	14	16,8	10,2	0,44	30 000	17 000	0,15	6007-2RZTN9/HC5C3WT
	72	17	27	15,3	0,655	28 000	15 000	0,26	6207-2RZTN9/HC5C3WT
40	68	15	17,8	11	0,49	28 000	15 000	0,19	6008-2RZTN9/HC5C3WT
	80	18	32,5	19	0,8	24 000	14 000	0,34	6208-2RZTN9/HC5C3WT
45	85	19	35,1	21,6	0,915	22 000	13 000	0,42	6209-2RZTN9/HC5C3WT
	100	25	55,3	31,5	1,34	20 000	4 500	0,77	6309-2RS1TN9/HC5C3WT

¹⁾ Valid for basic design bearings (i.e. seals removed from the bearings)

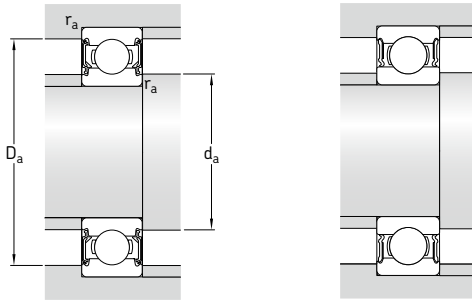

Dimensions					Abutment and fillet dimensions				Calculation factors	
d	d ₁	d ₂	D ₂	r _{1,2} min.	d _a min.	d _a max.	D _a max.	r _a max.	k _r	f ₀
mm	mm	mm	mm	mm	mm	mm	mm	mm	-	-
5	8,4	-	13,3	0,3	7,4	8,3	13,6	0,3	0,025	8,4
6	-	9,5	16,5	0,3	7,4	9,4	16,6	0,3	0,025	13
7	-	9,5	16,5	0,3	9	9,4	17	0,3	0,025	13
	-	10,6	19,2	0,3	9,4	10,5	19,6	0,3	0,025	12
8	-	10,6	19,2	0,3	10	10,5	20	0,3	0,025	12
10	-	13	22,6	0,3	12	12,5	24	0,3	0,025	12
	-	15,2	24,8	0,6	14,2	15	25,8	0,6	0,025	13
12	-	15,2	24,8	0,3	14	15	26	0,3	0,025	13
	-	16,6	27,4	0,6	16,2	16,5	27,8	0,6	0,025	12
15	-	18,7	28,2	0,3	17	18,5	30	0,3	0,025	14
	-	19,4	30,4	0,6	19,2	19,4	30,8	0,6	0,025	13
17	-	20,7	31,4	0,3	19	20,5	33	0,3	0,025	14
	-	22,2	35	0,6	21,2	22	35,8	0,6	0,025	13
20	-	24,9	37,2	0,6	23,2	24,5	38,8	0,6	0,025	14
	-	26,3	40,6	1	25,6	26	41,4	1	0,025	13
25	-	29,7	42,2	0,6	28,2	29,5	43,8	0,6	0,025	14
	-	31,8	46,3	1	30,6	31,5	46,4	1	0,025	14
30	38,2	-	49	1	34,6	-	50,4	1	0,025	15
	40,3	-	54,1	1	35,6	-	56,4	1	0,025	14
35	43,7	-	55,6	1	39,6	-	57,4	1	0,025	15
	46,9	-	62,7	1,1	42	-	65	1	0,025	14
40	49,2	-	61,1	1	44,6	-	63,4	1	0,025	15
	52,6	-	69,8	1,1	47	-	73	1	0,025	14
45	57,6	-	75,2	1,1	52	-	78	1	0,025	14
	62,1	-	86,7	1,5	54	-	91	1,5	0,03	13

15F.2 Sealed hybrid deep groove ball bearings d 50 – 75 mm

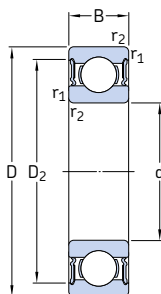

Principal dimensions			Basic load ratings		Fatigue load limit	Speed ratings		Mass	Designation
d	D	B	dynamic	static		Reference speed ¹⁾	Limiting speed		
mm	mm	mm	kN	kN	kN	r/min	r/min	kg	–
50	90	20	37,1	23,2	0,98	20 000	4 800	0,44	6210-2RS1/HC5C3WT
	110	27	65	38	1,6	18 000	4 300	0,92	6310-2RS1/HC5C3WT
55	100	21	46,2	29	1,25	19 000	4 300	0,59	6211-2RS1/HC5C3WT
	120	29	74,1	45	1,9	17 000	3 800	1,2	6311-2RS1/HC5C3WT
60	110	22	55,3	36	1,53	17 000	4 000	0,71	6212-2RS1/HC5C3WT
	130	31	85,2	52	2,2	15 000	3 400	1,5	6312-2RS1/HC5C3WT
65	120	23	58,5	40,5	1,73	16 000	3 600	0,92	6213-2RS1/HC5C3WT
	140	33	97,5	60	2,5	14 000	3 200	2,15	6313-2RS1/HC5C3WT
70	125	24	63,7	45	1,9	15 000	3 400	1	6214-2RS1/HC5C3WT
75	130	25	68,9	49	2,04	14 000	3 200	1,05	6215-2RS1/HC5C3WT

¹⁾ Valid for basic design bearings (i.e. seals removed from the bearings)

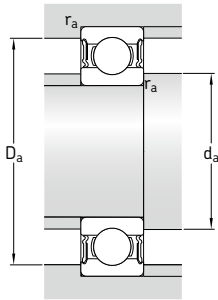

Dimensions				Abutment and fillet dimensions			Calculation factors	
d	d_1 ~	D_2 ~	$r_{1,2}$ min.	d_a min.	D_a max.	r_a max.	k_f	f_0
mm				mm			-	
50	62,5	81,6	1,1	57	83	1	0,025	14
	68,7	95,2	2	61	99	2	0,03	13
55	69	89,4	1,5	64	91	1,5	0,025	14
	75,3	104	2	66	109	2	0,03	13
60	75,5	98	1,5	69	101	1,5	0,025	14
	81,8	112	2,1	72	118	2	0,03	13
65	83,3	106	1,5	74	111	1,5	0,025	15
	88,3	121	2,1	77	128	2	0,03	13
70	87	111	1,5	79	116	1,5	0,025	15
75	92	117	1,5	84	121	1,5	0,025	15

15F.3 XL hybrid deep groove ball bearings

d 110 – 180 mm

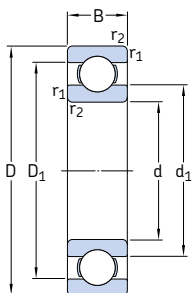

Principal dimensions			Basic load ratings ¹⁾		Fatigue load limit P_u	Speed ratings		Mass kg	Designation
d	D	B	dynamic C	static C_0		Reference speed	Limiting speed		
mm			kN		kN	r/min		-	
110	240	50	188	175	4,15	8 000	4 300	9,1	6322/HC5C3S0VA970
120	260	55	201	200	4,55	7 000	4 000	12,5	6324/HC5C3S0VA970
130	280	58	213	223	4,9	6 700	3 800	15,5	6326/HC5C3S0VA970
140	300	62	266	266	7,1	6 300	3 600	15,5	6328/HC5C3S0VA970
150	320	65	289	306	7,8	6 000	3 200	20,5	6330/HC5C3S0VA970
160	340	68	331	391	7,65	5 300	2 800	24	6332/HC5C3S0VA970
170	360	72	331	391	7,65	5 300	2 800	30	6334/HC5C3S0VA970
180	380	75	331	391	7,65	5 300	2 800	36,5	6336/HC5C3PS0VA970

¹⁾ Effective values for these specific hybrid deep groove ball bearings

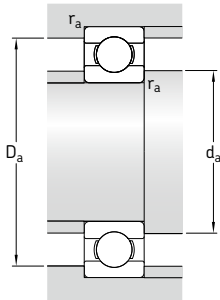

Dimensions				Abutment and fillet dimensions			Calculation factors	
d	d ₁ ~	D ₁ ~	r _{1,2} min.	d _a min.	D _a max.	r _a max.	k _r	f ₀
mm				mm			-	
110	160	198	3	124	226	2,5	0,025	15
120	175	216	3	134	246	2,5	0,025	15
130	189	228	4	147	263	3	0,025	15
140	189	250	4	157	283	3	0,03	14
150	206	265	4	167	303	3	0,03	14
160	236	295	4	177	323	3	0,03	14
170	236	295	4	187	343	3	0,03	14
180	236	295	4	197	363	3	0,03	14

15F.4 Hybrid cylindrical roller bearings

d 40 – 100 mm

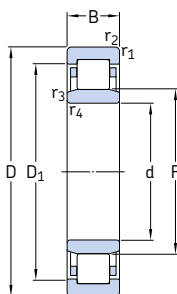

Principal dimensions			Basic load ratings dynamic static		Fatigue load limit	Speed ratings Reference speed Limiting speed		Mass	Designation
d	D	B	C	C ₀	P _u				
mm			kN		kN	r/min		kg	–
40	68	15	25,5	26,5	3,35	12 000	18 000	0,21	NU 1008 ML/HC5C3
45	75	16	45,7	54	6,8	11 000	11 000	0,19	NU 1009 ECP/HC5C3
50	80	16	47,3	57	7,2	9 500	9 500	0,23	NU 1010 ECP/HC5C3
	90	20	66	72	9,15	7 500	9 000	0,49	NU 210 ECM/HC5C3
	110	27	112	116	15,3	6 000	8 000	0,93	NU 310 ECM/HC5C3
55	90	18	57,2	69,5	9	8 500	8 500	0,4	NU 1011 ECM/HC5C3
	100	21	85,8	100	12,9	7 000	8 000	0,54	NU 211 ECM/HC5C3
	120	29	138	146	19	5 600	7 000	1,15	NU 311 ECM/HC5C3
60	95	18	38	45,5	5,85	8 000	8 000	0,44	NU 1012 M/HC5C3
	110	22	96,8	106	14	6 300	7 500	0,64	NU 212 ECM/HC5C3
	130	31	154	163	21,2	5 000	6 700	1,45	NU 312 ECM/HC5C3
65	100	18	62,7	81,5	10,6	7 500	7 500	0,38	NU 1013 ECP/HC5C3
	120	23	110	122	16	5 600	6 700	0,83	NU 213 ECM/HC5C3
	140	33	183	196	25,5	4 800	6 000	1,75	NU 313 ECM/HC5C3
70	110	20	79,2	98	12,9	7 000	7 000	0,53	NU 1014 ECP/HC5C3
	125	24	121	140	18,6	5 300	6 300	1,1	NU 214 ECM/HC5C3
	150	35	209	228	29	4 300	5 600	2,15	NU 314 ECM/HC5C3
75	115	20	58,3	71	9,3	6 700	6 700	0,61	NU 1015 M/HC5C3
	130	25	132	160	21,2	5 300	6 000	1,2	NU 215 ECM/HC5C3
80	125	22	102	134	17,3	6 000	6 000	0,88	NU 1016 ECM/HC5C3
	140	26	142	173	22	4 800	5 600	1,5	NU 216 ECM/HC5C3
85	130	22	72,1	91,5	11,6	6 000	6 000	0,95	NU 1017 M/HC5C3
	150	28	168	200	25,5	4 500	5 300	1,75	NU 217 ECM/HC5C3
90	140	24	85,8	110	13,7	5 600	5 600	1,2	NU 1018 M/HC5C3
95	145	24	88	116	14,3	5 300	8 000	1,3	NU 1019 ML/HC5C3
100	150	24	89,7	122	15	5 000	5 000	1,3	NU 1020 M/HC5C3

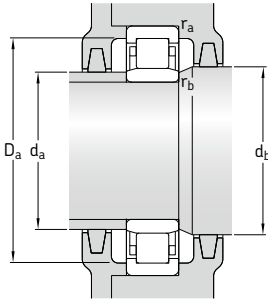

Dimensions						Abutment and fillet dimensions						Calculation factor
d	D ₁	F	r _{1,2} min.	r _{3,4} min.	s ¹⁾	d _a min.	d _a max.	d _b min.	D _a max.	r _a max.	r _b max.	k _r
mm	mm	mm	mm	mm	mm	mm	mm	mm	mm	mm	mm	-
40	57,6	47	1	0,6	2,4	43,2	45	49	63,4	1	0,6	0,1
45	65,3	52,5	1	0,6	0,9	48,2	51	54	70,4	1	0,6	0,1
50	70	57,5	1	0,6	1	53,2	56	60	75,4	1	0,6	0,1
	78	59,5	1,1	1,1	1,5	57	57	62	83	1	1	0,15
	92,1	65	2	2	1,9	61	63	67	99	2	2	0,15
55	79	64,5	1,1	1	0,5	59,6	63	67	84	1	1	0,1
	86,3	66	1,5	1,1	1	62	64	68	91	1,5	1	0,15
	101	70,5	2	2	2	66	68	73	109	2	2	0,15
60	81,6	70,1	1,1	1,1	2,9	64,6	68	72	89	1	1	0,1
	95,7	72	1,5	1,5	1,4	69	70	74	101	1,5	1,5	0,15
	110	77	2,1	2,1	2,1	72	74	79	118	2	2	0,15
65	88,5	74	1,1	1	1	69,6	72	77	94	1	1	0,1
	104	78,5	1,5	1,5	1,4	74	76	81	111	1,5	1,5	0,15
	119	65	2,1	2	2,2	77	80	85	128	2	2	0,15
70	97,5	79,5	1,1	1	1,3	74,6	78	82	104	1	1	0,1
	109	83,5	1,5	1,5	1,2	79	81	86	116	1,5	1,5	0,15
	127	89	2,1	2,1	1,8	82	86	91	138	2	2	0,15
75	101	85	1,1	1	3	79,6	83	87	109	1	1	0,1
	114	88,5	1,5	1,5	1,2	84	86	91	121	1,5	1,5	0,15
80	109	91,5	1,1	1	3,3	86	90	94	119	1	1	0,1
	123	95,3	2	2	1,4	91	93	98	129	2	2	0,15
85	114	96,5	1,1	1	3,3	89,6	95	99	124	1	1	0,1
	131	100,5	2	2	1,5	96	98	103	139	2	2	0,15
90	122	103	1,5	1,1	3,5	96	101	106	133	1,5	1	0,1
95	127	108	1,5	1,1	3,5	101	106	111	138	1,5	1	0,1
100	132	113	1,5	1,1	3,5	106	111	116	143	1,5	1	0,1

¹⁾ Permissible axial displacement from the normal position of one bearing ring relative to the other.



15G NoWear coated bearings

NoWear coating	1242
Designs and variants	1245
Cages	1245
Bearing data	1245
Dimension standards, tolerances, internal clearance, misalignment, defect frequencies	
Loads	1245
Minimum load	1245
Load carrying capacity, equivalent dynamic bearing load, equivalent static bearing loads	1245
Temperature limits	1245
Permissible speed	1245
Lubrication	1245
Designation system	1245

NoWear coating

NoWear is a wear-resistant carbon coating that can be applied to the rolling elements and inner ring raceway(s) of a bearing (designation suffix L7DA) or only the rolling elements (designation suffix L5DA) (→ **fig. 1**). A physical vapour deposition process applies the wear-resistant carbon coating ranging from 1 to 3 µm depending on the size of the bearing. The hardness of the coating is 1 200 HV10.

NoWear coated bearing surfaces retain the toughness of the underlying material while adopting the hardness, improved friction properties and wear-resistance of the coating.

During the running-in period, minute amounts of the coating material are transferred to the counter surfaces. This transfer reduces friction and improves resistance against wear and smearing, even in bearings where only the rolling elements are coated.



NoWear coated bearings are designed to extend service life, relubrication intervals and to withstand severe operating conditions including:

- increased risk of smearing
- insufficient lubricating film for undisturbed bearing operation ($\kappa < 1$)
- sudden load variations
- light loads
- rapid speed changes
- vibration and oscillations
- high operating temperatures

More information

Bearing life and load ratings	63
Design considerations	159
Bearing systems	160
Recommended fits	169
Abutment and fillet dimensions	208
Lubrication	239
Mounting, dismantling and bearing care	271

NoWear coated bearings open up new possibilities to existing applications operating under severe conditions. They do not require major design changes and provide new design possibilities. Typical applications where NoWear coated bearings are used include:

- paper machines
- marine and offshore applications
- fans
- compressors
- hydraulic pumps
- gearboxes
- motors

For demanding applications where NoWear coated bearings are being considered, several operating parameters must be taken into consideration and weighed against each other. Therefore, SKF recommends contacting the SKF application engineering service prior to selecting NoWear coated bearings.

NoWear coated bearings are not intended for vacuum or other completely dry running applications. The coating does not act as a barrier against oxygen and is therefore not recommended as a corrosion inhibitor.

Bearing service life

The extended bearing service life that NoWear can provide in high-speed, lightly loaded applications is difficult to calculate and depends on a variety of factors. However, experience has shown a multifold improvement in bearing service life.

For greased bearings that operate at speeds near or above the permissible speed, or at high temperatures that shorten the grease life, using NoWear extends relubrication intervals.

When the objective is to extend bearing service life in applications with heavy loads and marginal lubrication conditions, NoWear can be a solution. However, NoWear cannot protect the bearing against spalling as a result of constant heavy loads. Under heavy loads the maximum shear stresses are located below the coating within the bearing steel, which still has the properties of standard steel.

156 NoWear coated bearings

Table 1

NoWear coated bearings – standard assortment

Bearing type Symbol	Range	Available variants	
	Deep groove ball bearings d = 15 to 140 mm	L5DA	L7DA
	Angular contact ball bearings d = 15 to 140 mm	L5DA	L7DA
	Cylindrical roller bearings d = 15 to 220 mm d > 220 mm	L5DA L5DA	L7DA –
	Needle roller bearings d = 15 to 220 mm d > 220 mm	L5DA L5DA	L7DA –
	Spherical roller bearings d = 15 to 220 mm d > 220 mm	L5DA L5DA	L7DA –
	CARB toroidal roller bearings d = 15 to 220 mm d > 220 mm	L5DA L5DA	L7DA –
	Thrust ball bearings d = 15 to 110 mm	L5DA	–
	Spherical roller thrust bearings all sizes	L5DA	–

The ranges are general guidelines only and may vary between the dimension series. For additional information, contact SKF.

Designs and variants

The most commonly used NoWear coated bearings have only the rolling elements coated (designation suffix L5DA). They are recommended for applications where the bearing load is light to normal, or where vibration and oscillating movements occur.

NoWear coated bearings that have the inner ring raceway(s) and rolling elements coated (designation suffix L7DA) are recommended for any of the following operating conditions:

- abrasive contaminants that can cause premature wear
- heavy loads
- unusual lubrication conditions such as bearings lubricated by the process media

Most SKF rolling bearings can be supplied as NoWear coated bearings (→ **table 1**). For variants not listed in **table 1**, contact the SKF application engineering service.

Cages

Refer to *Cages* in the relevant product chapter of the standard bearing.

Bearing data

Dimension standards, tolerances, internal clearance, misalignment, defect frequencies

Refer to *Bearing data* in the relevant product chapter of the standard bearing.

Loads

Minimum load

Due to the material combination of NoWear/ steel in the contact area, the risk of smearing damage is reduced. NoWear coated bearings are recommended for applications with light loads in combination with high speeds.

Load carrying capacity, equivalent loads

Refer to *Loads* in the relevant product chapter of the standard bearing.

Temperature limits

The NoWear coating withstands temperatures of up to 350 °C (660 °F). For temperature limits of the bearing, refer to *Temperature limits* in the relevant product chapter of the standard bearing.

Permissible speed

Refer to *Permissible speed* in the relevant product chapter of the standard bearing.

Lubrication

In general, the same lubrication guidelines are valid for NoWear coated bearings as for standard bearings (→ *Lubrication*, **page 239**). However, NoWear coated bearings can operate reliably even when adequate surface separation cannot be achieved by the lubricant ($\kappa < 1$). NoWear can prevent direct metal-to-metal contact between the rolling elements and raceways. It might be possible to reduce the need for EP and AW additives in the lubricant when using a NoWear coated bearing, as the coating already acts as a powerful additive.

Designation system

Refer to *Designation system* in the relevant product chapter of the standard bearing.

The designation suffixes used to identify NoWear coated bearings are explained in the following.

- L5DA** Coated rolling elements
L7DA Coated rolling elements and inner ring raceway(s)



15H Polymer ball bearings

Designs and variants 1248

Single row deep groove ball bearings . . 1249

Thrust ball bearings 1249

Cages 1249

Materials 1250

 Chemical resistance 1251

Bearing data 1252

(Dimension standards, tolerances,
internal clearance)

Loads 1254

(Dynamic load carrying capacity,
calculation example, static load carrying
capacity)

Temperature limits and thermal expansion 1256

Permissible speed 1258

 Calculation example 1258

Design of bearing arrangements 1259

 Shaft and housing fits 1259

Factors influencing bearing performance 1259

Designation system 1260

Product tables

15H.1 Polymer single row deep
 groove ball bearings 1262

15H.2 Polymer thrust ball bearings . . . 1266

15H Polymer ball bearings

SKF polymer ball bearings are typically used in applications where resistance to moisture or chemicals is essential and steel bearings cannot be used or only with certain restrictions. In those applications, polymer ball bearings are an excellent solution from both a technical and economic perspective as they are characterized by the following properties:

- corrosion and chemical resistant
- high wear- and fatigue-resistant polymer
- self lubricating (no lubricant required)
- low coefficient of friction
- quiet running
- lightweight
- high specific strength (strength to weight ratio)
- high dimensional stability due to the low tendency to creep
- low lifecycle costs
- electrical insulator

These properties make polymer ball bearings appropriate for the following industries and applications:

- food and beverage industry
- medical and pharmaceutical industry
- chemical industry
- textile industry
- electrical industry
- photographic industry
- modelling and lightweight applications
- vacuum applications
- office products

Designs and variants

The standard assortment of SKF polymer ball bearings listed in this catalogue constitutes the most commonly used sizes of:

- single row deep groove ball bearings (→ **fig. 1**)
- thrust ball bearings (→ **fig. 2**)

Both bearing designs have uninterrupted raceways and are non-separable. Standard bearings are only available as open bearings (without seals or shields).

On request, other polymer bearings or units are available (→ **fig. 3**). Customized polymer bearings can be manufactured economically even in small quantities. Integrated functions (e.g. gearing, specific shape of the bore, etc.) that can reduce the number of components and assembly costs are also possible. Examples of those bearings, which are not listed in this catalogue, include:

- inch single row deep groove ball bearings
- full complement single row deep groove ball bearings
- sealed single row deep groove ball bearings
- double row deep groove ball bearings
- track runner bearings
- Y-bearings and Y-bearing units
- special size bearings
- bearings or components made of other materials
- bearing units with integrated functions

NOTE: Polymer ball bearings cannot accommodate the same heavy loads or high speeds as same-sized steel bearings.



Fig. 1

Single row deep groove ball bearings

SKF supplies standard single row deep groove ball bearings in various dimension series for shaft diameters ranging from 3 to 60 mm. They consist of:

- polymer rings
- balls made of stainless steel or glass
- a polymer cage

Thrust ball bearings

SKF supplies standard thrust ball bearings in various dimension series for shaft diameters ranging from 10 to 45 mm. Thrust ball bearings consist of polymer washers and a full complement ball set. The ball set per bearing consists of two different ball materials to reduce friction and frictional heat. Balls made of the selected material are fitted alternately with balls made of the same polymer as the washers.



Fig. 2

Cages

Single row deep groove ball bearings are fitted with a snap-type, ball centred polymer cage (→ fig. 4).

Thrust ball bearings have a full complement ball set and do not have a cage.



Fig. 3

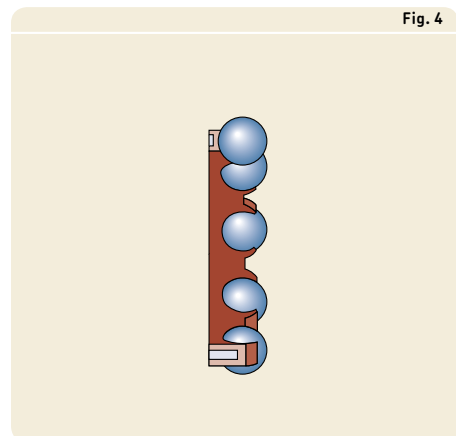

Fig. 4

15H Polymer ball bearings

Materials

SKF polymer ball bearings can be manufactured from a variety of materials and material combinations. The selected materials depend on the application conditions. Polymer ball bearings are available in the four standard material combinations listed in **table 1** for single row deep groove ball bearings and in **table 2** for thrust ball bearings. A four-digit combination designation suffix (→ *Designation system*, **page 1260**) identifies the selected materials.

Table 1

Standard material combinations for single row deep groove ball bearings

Combination	Rings	Balls	Cage	Combination, designation suffix
1	Polyoxymethylene (POM)	Stainless steel	Polyamide 66 (PA66)	11TN
2	Polyoxymethylene (POM)	Glass	Polyamide 66 (PA66)	11QN
3	Polypropylene (PP)	Stainless steel	Polypropylene (PP)	22T2
4	Polypropylene (PP)	Glass	Polypropylene (PP)	22Q2

Table 2

Standard material combinations for thrust ball bearings

Combination	Washers and alternate balls	Balls (selected material)	Combination, designation suffix
1	Polyoxymethylene (POM)	Stainless steel	11T1
2	Polyoxymethylene (POM)	Glass	11Q1
3	Polypropylene (PP)	Stainless steel	22T2
4	Polypropylene (PP)	Glass	22Q2

Chemical resistance

Most polymers can resist the damaging effects of commonly used chemicals.

Polypropylene (PP) resists acids, alkalis, salts and salt solutions, alcohols, oils, greases, waxes and many solvents. However, exposure to aromatic compounds and halogenated hydrocarbons cause the material to swell. PP also does not resist strong oxidizing media like nitric acid, chromates or halogens.

Polyoxymethylene (POM) resists weak acids, weak and strong alkalis and organic solvents as well as gasoline, benzene, oils and alcohols.

Polyamide 66 (PA66) resists almost all organic solvents as well as some weak acids and alkalis.

Table 3 provides an overview of the chemical resistance of available materials to common substances.

For additional information, refer to *Factors influencing bearing performance* (→ page 1259).

Table 3

Chemical resistance of available materials to common substances																			
Chemical group	Standard materials					Alternative materials													
	POM/POM sooted	PP	PA66	Stainless steel 1.4401	Glass	PE	PEEK	PET	PVDF	PPS	PI	Borosilicate glass	Stainless steel 1.4034	Titanium	Si ₃ N ₄	Al ₂ O ₃	ZrO ₂	Brass	
Hydrocarbons																			
– aliphatic	+	+	+	0	+	+	+	+	+	+	+	+	+	+	+	+	+	+	+
– aromatic	+	+	0	+	0	0	+	0	+	0	0	+	+	+	+	+	+	+	+
– halogenic	+	0	0	–	0	0	0	0	+	+	0	+	+	+	+	+	+	+	0
Acids																			
– weak	0	+	0	0	+	+	+	+	+	+	+	+	+	+	+	+	+	+	0
– strong	–	+	–	0	0	+	–	0	+	+	+	+	–	0	+	+	+	+	–
– oxidizing	–	–	–	0	+	0	–	0	–	–	–	–	–	–	–	–	–	–	–
– hydrofluoric acid	–	0	–	0	–	0	–	–	+	0	0	–	–	–	0	–	–	–	–
Alkalis																			
– weak	+	+	0	0	+	+	+	0	+	+	+	+	+	0	0	+	+	+	–
– strong	+	+	0	0	0	+	+	–	–	0	0	0	0	0	–	+	+	+	–
Mineral lubricants	+	+	+	+	+	+	+	+	+	+	+	+	+	+	+	+	+	+	+
Gasoline	+	+	+	+	+	+	+	+	+	+	+	+	+	+	+	+	+	+	+
Alcohols	+	+	+	+	+	+	+	+	+	+	+	+	+	+	+	+	+	+	+
Acetone	+	+	+	+	+	+	+	0	–	+	0	+	+	+	+	+	+	+	+
	+ = good resistance: Can generally be used.					0 = limited resistance: Bearing suitability should be tested under operating conditions.					– = low resistance: Cannot be used.								

Bearing data

	Single row deep groove ball bearings	Thrust ball bearings
Dimension standards	Boundary dimensions: ISO 15, except for chamfer dimensions	Boundary dimensions: ISO 104, except for chamfer dimensions
Tolerances	<p>The tolerances for polymer bearings (→ table 4) are not standardized nationally or internationally. Generally, they are larger than the tolerances for steel bearings and have been proven in practice. When applied properly, the larger tolerances do not have an adverse effect on bearing service life.</p> <p>For additional information, contact the SKF application engineering service.</p>	
Internal clearance	Values (→ table 5)	–

Table 4

Tolerances for polymer bearings

Single row deep groove and thrust ball bearings

Bore diameter				Outside diameter				Single row deep groove ball bearings				Thrust ball bearings					
d		Tolerance		D		Tolerance		Width		Tolerance		Height		Tolerance			
over	incl.	high	low	over	incl.	high	low	B	over	incl.	high	low	H	over	incl.	high	low
mm		µm		mm		µm		mm		µm		mm		µm			
-	3	30	-30	-	30	40	-40	4	25	0	-100	9	21	200	-200		
3	17	30	-30	30	47	50	-50										
17	50	40	-40	47	80	60	-60										
50	60	50	-50	80	100	80	-80										

Table 5

Radial internal clearance for polymer single row deep groove ball bearings

Bore diameter		Radial internal clearance	
d		min.	max.
over	incl.		
mm		µm	
-	9	60	140
9	17	70	150
17	20	80	160
20	25	80	170
30	35	90	180
35	45	100	200
45	60	110	210

Loads

There are no standardized calculation methods, either nationally or internationally, to calculate basic load ratings for polymer ball bearings. According to the current state of technology, an analytical life calculation is not possible.

For slow speeds ($n < 25$ r/min), the static load carrying capacity is to be used.

<p>Dynamic load carrying capacity</p>	<p>The dynamic load carrying capacity is an indicator for the operational load at which the bearing fulfils its function in the majority of applications. The dynamic load carrying capacity depends on the operating conditions and needs to be adjusted under the following conditions:</p> <ul style="list-style-type: none"> • operating temperature $T > 50$ °C (120 °F) • rotational speed $n \geq 20\%$ of the limiting speed n_{lim} (→ product tables) $C_{adj} = f_T f_n C$ <p>Calculation example Bearing 6301/HR11TN, $n = 650$ r/min, $T = 90$ °C (195 °F)</p> <p>From the product tables:</p> <ul style="list-style-type: none"> • $C = 0,31$ kN • $n_{lim} = 1\ 300$ r/min <p>From diagram 1, page 1256:</p> <ul style="list-style-type: none"> • with $T = 90$ °C (195 °F) and rings made of POM → $f_T \approx 0,87$ • with $n/n_{lim}: (650/1\ 300) \times 100 = 50\%$ → $f_n \approx 0,85$ $C_{adj} = 0,87 \times 0,85 \times 0,31 = 0,229$ kN
<p>Static load carrying capacity</p>	<p>The static load carrying capacity is the maximum load that a bearing can accommodate at standstill without sustaining damage to the balls or raceways.</p> <p>The static load carrying capacity depends on the operating temperature and should be adjusted at operating temperatures $T > 50$ °C (120 °F).</p> $C_{0adj} = f_T C_0$

Symbols

C	= basic dynamic load rating [kN] (→ product tables)
C_{adj}	= adjusted dynamic load carrying capacity [kN]
C_0	= basic static load rating [kN] (→ product tables)
C_{0adj}	= adjusted static load carrying capacity [kN]
f_n	= adjustment factor for speed (→ diagram 1, page 1256)
f_T	= adjustment factor for operating temperature (→ diagram 1, page 1256)
n	= rotational speed [r/min]
n_{lim}	= limiting speed [r/min] (→ product tables)
T	= operating temperature [°C (°F)]

15H Polymer ball bearings

Diagram 1

Adjustment factors for static and dynamic load carrying capacities for POM and PP ring materials

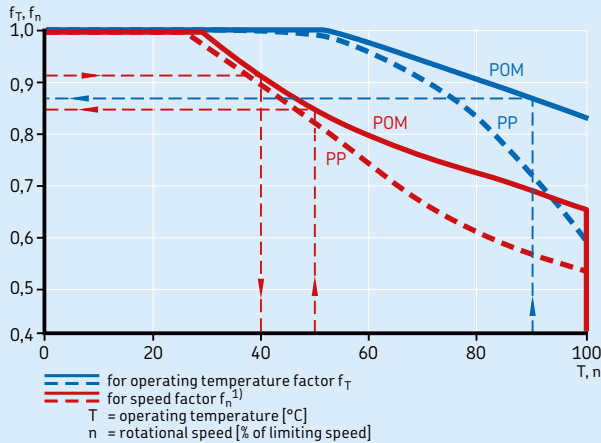

¹⁾ For speeds below 25 r/min, the static load carrying capacity is to be used.

Temperature limits and thermal expansion

The permissible operating temperature for polymer ball bearings is limited by the type of polymer. **Diagram 2** provides a summary of the operating temperatures for polymer materials. When temperatures outside the permissible range or below 0 °C (30 °F) are expected, contact the SKF application engineering service.

In combination with the operating temperature, thermal expansion is also important. The coefficient of thermal expansion (→ **diagram 3**) enables designers to predict the effects that temperature has on bearing internal clearance. The coefficient of thermal expansion for a polymer can be up to 10 times greater than for steel. Even the coefficient of thermal expansion for different polymers can vary considerably. Therefore, thermal expansion can have a significant influence on bearing internal clearance and should be considered when selecting shaft and housing fits (→ *Shaft and housing fits*, page 1259) and when selecting the bearing materials.

Diagram 2

Operating temperature range for polymers

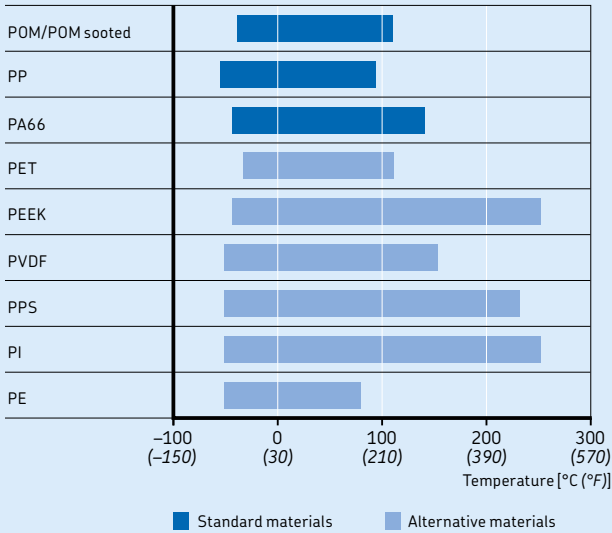
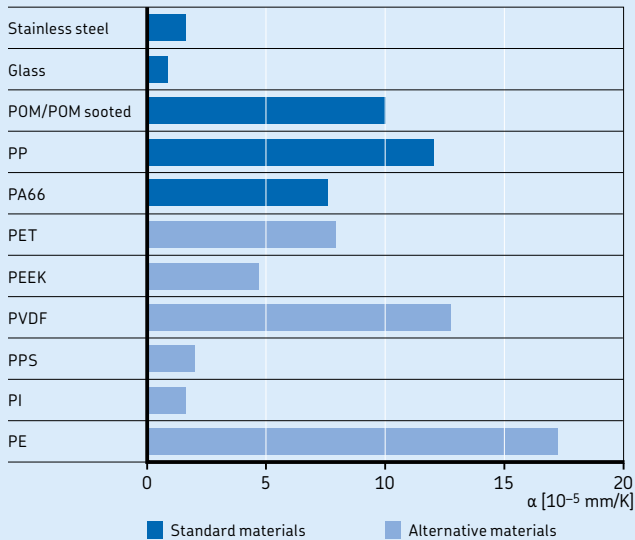

Diagram 3

Coefficient of thermal expansion α



Permissible speed

For polymer ball bearings, the limiting speed (→ **product tables**) is to be used as the determining factor to estimate the permissible speed.

The permissible speed depends on the applied load and the operating temperature. When both values are known, the adjustment factor for speed f_n is to be calculated using

$$f_n = \frac{P}{f_T C}$$

where

f_n = adjustment factor for speed

P = applied bearing load [kN]

f_T = adjustment factor for temperature
(→ **diagram 1, page 1256**)

C = basic dynamic load rating [kN]
(→ **product tables**)

Starting with the calculated adjustment factor for speed f_n from the y-axis (→ **diagram 1, page 1256**), the percentage of the limiting speed can be determined and the permissible speed can be calculated.

Calculation example

- **Input data**
Bearing 6301/HR11TN, $P = 0,245$ kN,
 $T = 90$ °C (195 °F)
- **Calculate the adjustment factor for speed f_n**
From the **product tables**:
 $C = 0,31$ kN
From **diagram 1, page 1256**:
With $T = 90$ °C (195 °F) and rings made of POM → $f_T \approx 0,87$

$$f_n = \frac{0,245}{0,87 \times 0,31} \approx 0,91$$

- **Calculate the permissible speed**
From the **product tables**:
 $n_{lim} = 1\,300$ r/min
From **diagram 1, page 1256**:
With $f_n = 0,91$ and rings made of POM the percentage of $n_{lim} \approx 40\%$

$$n_{perm} = \frac{n_{lim} \times 40}{100} = \frac{1\,300 \times 40}{100} \approx 520 \text{ r/min}$$

where

n_{perm} = permissible speed [r/min]

n_{lim} = limiting speed [r/min]
(→ **product tables**)

Design of bearing arrangements

Shaft and housing fits

Shaft and housing fits can have a significant influence on the internal clearance and the operating characteristics of polymer ball bearings. Therefore, SKF recommends approximately 20 µm interference fit for one ring only. Depending on the application, the interference fit can be on the shaft or in the housing. The other ring should have a loose fit.

Never subject both bearing rings to an interference fit as it preloads the bearing, causing it to fail prematurely.

These recommendations are only guidelines to calculate a fit. Thermal expansion of the bearing components under operating conditions must be taken into consideration.

For additional information, contact the SKF application engineering service.

Factors influencing bearing performance

In many applications, the performance of polymer ball bearings is influenced by factors (temperature, pressure, material tension, interaction with chemical substances, design features etc.) that are difficult to replicate in laboratory tests or to be considered by adjustment factors. Because of the complexity of these effects on these bearings, the information provided in this chapter should be used as a guideline and cannot substitute for field testing a selected polymer ball bearing in its specific application. Therefore, SKF recommends field testing a selected polymer ball bearing to make sure that it performs satisfactorily within the application.

For additional information, contact the SKF application engineering service.

15H Polymer ball bearings

Designation system

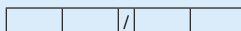

Basic designation

Listed in **diagram 2** (→ **page 43**)

Suffixes

Cage design

V Full complement of balls (no cage)

Materials

HR Polymer ball bearings

Material combination designation

Character 1 Outer ring

Character 2 Inner ring

Character 3 Balls

Character 4 Cage (single row deep groove ball bearings)
Alternate balls (thrust ball bearings)

Material codes:

1	Polyoxymethylene (POM)
2	Polypropylene (PP)
3	Polyethylene (PE)
6	Polyetheretherketone (PEEK)
8	Polyoxymethylene sooted (POM sooted)
B	Polyethylene terephthalate (PET)
D	Ceramic ZrO ₂
K	Polyvinylidene fluoride (PVDF)
L	Polyphenylsulfide (PPS)
M	Polyimide (PI)
N	Polyamide 66 (PA66)
P	Brass
Q	Glass
R	Borosilicate glass
S	Stainless steel 1.4034
T	Stainless steel 1.4401
W	Titanium
X	Ceramic Si ₃ N ₄
Z	Ceramic Al ₂ O ₃

The complete designation is printed on the package. Polymer ball bearings do not have the designation inscribed on the rings or washers.

15H.1 Polymer single row deep groove ball bearings

d 3 – 30 mm

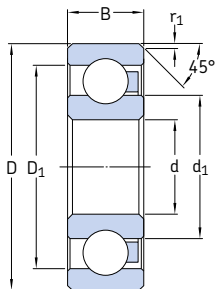

Principal dimensions			Basic load ratings dynamic ²⁾ static ³⁾		Limiting speed	Dimensions			Mass ¹⁾	Designations Bearing with stainless steel balls	glass balls
d	D	B	C	C ₀		d ₁	D ₁	r ₁ min.	g	-	
mm			kN		r/min	mm					
3	10	4	0,045	0,03	4 500	5,6	7,9	0,2	0,4	623/HR11TN	623/HR11QN
	10	4	0,03	0,025	3 960	5,6	7,9	0,2	0,3	623/HR22T2	623/HR22Q2
4	13	5	0,06	0,04	3 600	6,6	9,8	0,3	0,9	624/HR11TN	624/HR11QN
	13	5	0,04	0,03	3 170	6,6	9,8	0,3	0,7	624/HR22T2	624/HR22Q2
5	16	5	0,065	0,045	3 050	7,5	12,5	0,4	1,4	625/HR11TN	625/HR11QN
	16	5	0,045	0,035	2 680	7,5	12,5	0,4	1,3	625/HR22T2	625/HR22Q2
6	19	6	0,07	0,05	2 600	9	15,4	0,4	2,8	626/HR11TN	626/HR11QN
	19	6	0,05	0,04	2 290	9	15,4	0,4	2,4	626/HR22T2	626/HR22Q2
7	19	6	0,07	0,05	2 600	10,8	15,9	0,4	2,2	607/HR11TN	607/HR11QN
	19	6	0,05	0,04	2 290	10,8	15,9	0,4	1,7	607/HR22T2	607/HR22Q2
	22	7	0,08	0,055	2 200	11,5	17,9	0,4	3,9	627/HR11TN	627/HR11QN
	22	7	0,055	0,045	1 900	11,5	17,9	0,4	3,2	627/HR22T2	627/HR22Q2
8	22	7	0,08	0,055	2 200	11,5	17,9	0,4	3,6	608/HR11TN	608/HR11QN
	22	7	0,055	0,045	1 930	11,5	17,9	0,4	3	608/HR22T2	608/HR22Q2
9	24	7	0,09	0,06	2 050	13,4	19,9	0,4	7,8	609/HR11TN	609/HR11QN
	24	7	0,065	0,05	1 800	13,4	19,9	0,4	5,7	609/HR22T2	609/HR22Q2
	26	8	0,1	0,07	1 900	13,7	21,3	0,4	6,3	629/HR11TN	629/HR11QN
	26	8	0,07	0,055	1 670	13,7	21,3	0,4	5,2	629/HR22T2	629/HR22Q2
10	26	8	0,13	0,09	1 900	15,1	21,4	0,4	6,2	6000/HR11TN	6000/HR11QN
	26	8	0,09	0,07	1 670	15,1	21,4	0,4	5,1	6000/HR22T2	6000/HR22Q2
	28	8	0,13	0,09	1 900	15,1	20,9	0,4	7,3	16100/HR11TN	16100/HR11QN
	28	8	0,09	0,07	1 670	15,1	20,9	0,4	5,8	16100/HR22T2	16100/HR22Q2
30	9	0,16	0,11	1 650	17	23	0,9	8,9	6200/HR11TN	6200/HR11QN	
	30	9	0,11	0,09	1 450	17	23	0,9	7,1	6200/HR22T2	6200/HR22Q2
	35	11	0,28	0,19	1 400	18	26,9	0,9	17,5	6300/HR11TN	6300/HR11QN
	35	11	0,195	0,15	1 230	18	26,9	0,9	14,5	6300/HR22T2	6300/HR22Q2

¹⁾ Valid for bearings with stainless steel balls.

²⁾ Above 50 °C (120 °F) and/or above 20% of limiting speed consider reduction according to **diagram 1** (→ page 1256).

³⁾ Above 50 °C (120 °F) consider reduction according to **diagram 1** (→ page 1256).

Principal dimensions			Basic load ratings dynamic ²⁾ static ³⁾		Limiting speed	Dimensions			Mass ¹⁾	Designations Bearing with stainless steel balls	glass balls	
d	D	B	C	C ₀		d ₁	D ₁	r ₁ min.	g	-		
mm			kN		r/min	mm						
12	28	8	0,16	0,11	1 750	17,1	22,9	0,4	7,1	6001/HR11TN	6001/HR11QN	
	28	8	0,11	0,09	1 540	17,1	22,9	0,4	5,9	6001/HR22T2	6001/HR22Q2	
	32	10	0,22	0,15	1 550	18,2	25,7	0,9	11	6201/HR11TN	6201/HR11QN	
	32	10	0,155	0,12	1 360	18,2	25,7	0,9	9,9	6201/HR22T2	6201/HR22Q2	
	37	12	0,31	0,21	1 300	19,5	29,5	0,9	22	6301/HR11TN	6301/HR11QN	
	37	12	0,215	0,17	1 140	19,5	29,5	0,9	18,5	6301/HR22T2	6301/HR22Q2	
15	32	8	0,19	0,13	1 500	19,8	25,9	0,4	8	16002/HR11TN	16002/HR11QN	
	32	8	0,135	0,105	1 320	19,8	25,9	0,4	6,5	16002/HR22T2	16002/HR22Q2	
	32	9	0,2	0,14	1 500	20,6	26,4	0,4	9,1	6002/HR11TN	6002/HR11QN	
	32	9	0,14	0,11	1 320	20,6	26,4	0,4	7,4	6002/HR22T2	6002/HR22Q2	
	35	11	0,25	0,17	1 400	21,5	29	0,9	14,5	6202/HR11TN	6202/HR11QN	
	35	11	0,175	0,135	1 230	21,5	29	0,9	11	6202/HR22T2	6202/HR22Q2	
	42	13	0,37	0,26	1 200	23,7	33,7	0,9	27,5	6302/HR11TN	6302/HR11QN	
	42	13	0,26	0,21	1 060	23,7	33,7	0,9	23	6302/HR22T2	6302/HR22Q2	
	17	35	8	0,24	0,16	1 400	22,2	29,8	0,4	9,6	16003/HR11TN	16003/HR11QN
		35	8	0,17	0,13	1 230	22,2	29,8	0,4	7,9	16003/HR22T2	16003/HR22Q2
35		10	0,26	0,17	1 400	23,1	28,9	0,4	11,5	6003/HR11TN	6003/HR11QN	
35		10	0,18	0,135	1 230	23,1	28,9	0,4	9	6003/HR22T2	6003/HR22Q2	
40		12	0,32	0,22	1 250	24,2	32,7	0,9	19	6203/HR11TN	6203/HR11QN	
40		12	0,225	0,175	1 100	24,2	32,7	0,9	15,5	6203/HR22T2	6203/HR22Q2	
47		14	0,37	0,26	1 050	26,5	37,4	0,9	37,5	6303/HR11TN	6303/HR11QN	
47		14	0,26	0,21	920	26,5	37,4	0,9	31,5	6303/HR22T2	6303/HR22Q2	
20		42	8	0,29	0,19	1 150	26,5	34,5	0,4	14	16004/HR11TN	16004/HR11QN
		42	8	0,205	0,15	1 010	26,5	34,5	0,4	10,5	16004/HR22T2	16004/HR22Q2
	42	12	0,3	0,2	1 150	27,2	34,8	0,9	20,5	6004/HR11TN	6004/HR11QN	
	42	12	0,21	0,16	1 010	27,2	34,8	0,9	17	6004/HR22T2	6004/HR22Q2	
	47	14	0,42	0,27	1 050	28,5	38,5	0,9	33,5	6204/HR11TN	6204/HR11QN	
	47	14	0,295	0,215	920	28,5	38,5	0,9	27,5	6204/HR22T2	6204/HR22Q2	
	52	15	0,5	0,35	950	30,3	41,6	0,9	48,5	6304/HR11TN	6304/HR11QN	
	52	15	0,35	0,28	840	30,3	41,6	0,9	40,5	6304/HR22T2	6304/HR22Q2	
	25	47	8	0,31	0,21	1 050	32,3	40,9	0,4	19	16005/HR11TN	16005/HR11QN
		47	8	0,215	0,17	920	32,3	40,9	0,4	16	16005/HR22T2	16005/HR22Q2
47		12	0,36	0,24	1 050	32,2	39,8	0,9	24	6005/HR11TN	6005/HR11QN	
47		12	0,25	0,19	920	32,2	39,8	0,9	19,5	6005/HR22T2	6005/HR22Q2	
52		15	0,48	0,32	950	34	44	0,9	39,5	6205/HR11TN	6205/HR11QN	
52		15	0,335	0,255	840	34	44	0,9	32,5	6205/HR22T2	6205/HR22Q2	
62		17	0,6	0,4	725	37	50	0,9	76,5	6305/HR11TN	6305/HR11QN	
62		17	0,42	0,32	640	37	50	0,9	64	6305/HR22T2	6305/HR22Q2	
30		55	9	0,37	0,24	900	37,7	47,3	0,4	26	16006/HR11TN	16006/HR11QN
		55	9	0,26	0,19	790	37,7	47,3	0,4	21,5	16006/HR22T2	16006/HR22Q2
	55	13	0,42	0,28	900	38,2	46,8	0,9	35,5	6006/HR11TN	6006/HR11QN	
	55	13	0,295	0,225	790	38,2	46,8	0,9	29	6006/HR22T2	6006/HR22Q2	
	62	16	0,55	0,36	800	40,3	51,6	0,9	63,5	6206/HR11TN	6206/HR11QN	
	62	16	0,385	0,29	700	40,3	51,6	0,9	52,5	6206/HR22T2	6206/HR22Q2	
	72	19	0,70	0,46	675	44,7	59,2	1,4	114	6306/HR11TN	6306/HR11QN	
	72	19	0,490	0,37	590	44,7	59,2	1,4	95,5	6306/HR22T2	6306/HR22Q2	

¹⁾ Valid for bearings with stainless steel balls.

²⁾ Above 50 °C (120 °F) and/or above 20% of limiting speed consider reduction according to **diagram 1** (→ **page 1256**).

³⁾ Above 50 °C (120 °F) consider reduction according to **diagram 1** (→ **page 1256**).

15H.1 Polymer single row deep groove ball bearings

d 35 – 60 mm

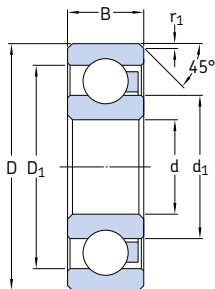

Principal dimensions			Basic load ratings dynamic ²⁾ static ³⁾		Limiting speed	Dimensions			Mass ¹⁾	Designations Bearing with stainless steel balls	glass balls	
d	D	B	C	C ₀		d ₁	D ₁	r ₁ min.	g	-	-	
mm			kN		r/min	mm						
35	62	9	0,41	0,27	800	43,7	53,3	0,4	32,5	16007/HR11TN	16007/HR11QN	
	62	9	0,285	0,215	700	43,7	53,3	0,4	26,5	16007/HR22T2	16007/HR22Q2	
	62	14	0,48	0,32	800	43,7	53,3	0,9	47,5	6007/HR11TN	6007/HR11QN	
	62	14	0,335	0,255	700	43,7	53,3	0,9	39	6007/HR22T2	6007/HR22Q2	
	72	17	0,62	0,41	700	47	60	0,9	95	6207/HR11TN	6207/HR11QN	
	72	17	0,435	0,33	620	47	60	0,9	80	6207/HR22T2	6207/HR22Q2	
	80	21	0,75	0,49	600	49,55	65,35	1,4	154	6307/HR11TN	6307/HR11QN	
	80	21	0,525	0,39	530	49,55	65,35	1,4	130	6307/HR22T2	6307/HR22Q2	
	40	68	9	0,45	0,3	750	49,4	58,6	0,4	37,5	16008/HR11TN	16008/HR11QN
		68	9	0,315	0,24	660	49,4	58,6	0,4	30,5	16008/HR22T2	16008/HR22Q2
68		15	0,52	0,35	750	49,2	58,8	0,9	56,5	6008/HR11TN	6008/HR11QN	
68		15	0,365	0,28	660	49,2	58,8	0,9	45,5	6008/HR22T2	6008/HR22Q2	
80		18	0,66	0,44	625	53	67	0,9	132	6208/HR11TN	6208/HR11QN	
80		18	0,46	0,35	550	53	67	0,9	113	6208/HR22T2	6208/HR22Q2	
90		23	0,8	0,52	575	56,1	73,75	1,9	208	6308/HR11TN	6308/HR11QN	
90		23	0,56	0,415	510	56,1	73,75	1,9	175	6308/HR22T2	6308/HR22Q2	
45	75	10	0,5	0,33	650	55	65	0,9	49	16009/HR11TN	16009/HR11QN	
	75	10	0,35	0,265	570	55	65	0,9	39,5	16009/HR22T2	16009/HR22Q2	
	75	16	0,56	0,38	650	54,7	65,3	0,9	75	6009/HR11TN	6009/HR11QN	
	75	16	0,39	0,305	570	54,7	65,3	0,9	61,5	6009/HR22T2	6009/HR22Q2	
	85	19	0,72	0,47	580	57,5	72,35	1,9	138	6209/HR11TN	6209/HR11QN	
	85	19	0,505	0,375	510	57,5	72,35	1,9	117	6209/HR22T2	6209/HR22Q2	
	100	25	0,9	0,54	500	62,18	82,65	1,9	296	6309/HR11TN	6309/HR11QN	
	100	25	0,63	0,43	440	62,18	82,65	1,9	255	6309/HR22T2	6309/HR22Q2	
	50	80	16	0,58	0,39	600	60	70	0,9	82	6010/HR11TN	6010/HR11QN
		80	16	0,405	0,31	530	60	70	0,9	67	6010/HR22T2	6010/HR22Q2
90		20	0,77	0,54	550	62,5	77,35	1,9	154	6210/HR11TN	6210/HR11QN	
90		20	0,54	0,43	480	62,5	77,35	1,9	130	6210/HR22T2	6210/HR22Q2	

¹⁾ Valid for bearings with stainless steel balls.

²⁾ Above 50 °C (120 °F) and/or above 20% of limiting speed consider reduction according to **diagram 1** (→ **page 1256**).

³⁾ Above 50 °C (120 °F) consider reduction according to **diagram 1** (→ **page 1256**).

Principal dimensions			Basic load ratings dynamic ²⁾ static ³⁾		Limiting speed	Dimensions			Mass ¹⁾	Designations Bearing with stainless steel balls	glass balls
d	D	B	C	C ₀		d ₁	D ₁	r ₁ min.			
mm			kN		r/min	mm			g	-	
55	90	18	0,6	0,4	550	66,3	78,7	0,9	121	6011/HR11TN	6011/HR11QN
	90	18	0,42	0,32	480	66,3	78,7	0,9	100	6011/HR22T2	6011/HR22Q2
	100	21	0,8	0,6	500	69,06	85,8	2,4	207	6211/HR11TN	6211/HR11QN
	100	21	0,56	0,48	440	69,06	85,8	2,4	177	6211/HR22T2	6211/HR22Q2
60	95	18	0,64	0,42	500	70,2	84,5	1,9	127	6012/HR11TN	6012/HR11QN
	95	18	0,45	0,335	440	70,2	84,5	1,9	104	6012/HR22T2	6012/HR22Q2

¹⁾ Valid for bearings with stainless steel balls.

²⁾ Above 50 °C (120 °F) and/or above 20% of limiting speed consider reduction according to **diagram 1** (→ **page 1256**).

³⁾ Above 50 °C (120 °F) consider reduction according to **diagram 1** (→ **page 1256**).

15H.2 Polymer thrust ball bearings

d 10 – 45 mm

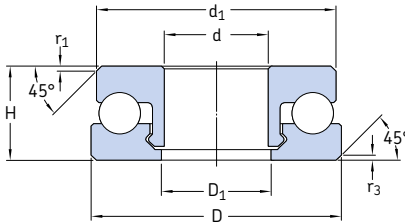

Principal dimensions			Basic load ratings		Limiting speed	Dimensions				Mass ¹⁾	Designations	
d	D	H	C	dynamic ²⁾	static ³⁾	d ₁	D ₁	r ₁	r ₃	g	Bearing with stainless steel balls	glass balls
mm			kN		r/min	mm		min.	min.		-	
10	24	9	0,25	0,2	600	23	11	0,2	0,5	5,2	51100 V/HR11T1	51100 V/HR11Q1
	24	9	0,22	0,175	550	23	11	0,2	0,5	4	51100 V/HR22T2	51100 V/HR22Q2
	26	11	0,26	0,21	600	25	11	0,2	0,5	7,9	51200 V/HR11T1	51200 V/HR11Q1
	26	11	0,23	0,185	550	25	11	0,2	0,5	6	51200 V/HR22T2	51200 V/HR22Q2
12	26	9	0,4	0,32	540	25	13	0,5	0,5	5,6	51101 V/HR11T1	51101 V/HR11Q1
	26	9	0,35	0,28	500	25	13	0,5	0,5	4,3	51101 V/HR22T2	51101 V/HR22Q2
	28	11	0,41	0,33	540	27	13	0,2	0,5	9,5	51201 V/HR11T1	51201 V/HR11Q1
	28	11	0,36	0,29	500	27	13	0,2	0,5	6,7	51201 V/HR22T2	51201 V/HR22Q2
15	28	9	0,625	0,5	500	27	16	0,2	0,5	6,1	51102 V/HR11T1	51102 V/HR11Q1
	28	9	0,55	0,44	460	27	16	0,2	0,5	4,7	51102 V/HR22T2	51102 V/HR22Q2
	32	12	0,65	0,52	500	31	16	0,2	0,5	11,5	51202 V/HR11T1	51202 V/HR11Q1
	32	12	0,57	0,46	460	31	16	0,2	0,5	8,8	51202 V/HR22T2	51202 V/HR22Q2
17	30	9	0,71	0,57	480	29	18	0,2	0,5	6,8	51103 V/HR11T1	51103 V/HR11Q1
	30	9	0,625	0,5	440	29	18	0,2	0,5	5,4	51103 V/HR22T2	51103 V/HR22Q2
	35	12	0,75	0,6	480	34	18	0,5	0,5	15	51203 V/HR11T1	51203 V/HR11Q1
	35	12	0,66	0,53	440	34	18	0,5	0,5	12	51203 V/HR22T2	51203 V/HR22Q2
20	35	10	0,81	0,65	460	34	21	0,4	0,5	10,5	51104 V/HR11T1	51104 V/HR11Q1
	35	10	0,71	0,57	420	34	21	0,4	0,5	8,1	51104 V/HR22T2	51104 V/HR22Q2
	40	14	0,86	0,69	460	39	21	0,5	0,5	20,5	51204 V/HR11T1	51204 V/HR11Q1
	40	14	0,75	0,6	420	39	21	0,5	0,5	16	51204 V/HR22T2	51204 V/HR22Q2
25	42	11	0,88	0,71	410	41	26	0,5	0,5	14,5	51105 V/HR11T1	51105 V/HR11Q1
	42	11	0,77	0,625	375	41	26	0,5	0,5	7,9	51105 V/HR22T2	51105 V/HR22Q2
	47	15	0,93	0,75	400	46	26	0,5	0,5	28,5	51205 V/HR11T1	51205 V/HR11Q1
	47	15	0,815	0,66	370	46	26	0,5	0,5	22	51205 V/HR22T2	51205 V/HR22Q2
	52	18	1,025	0,82	380	51	26	1	1	46	51305 V/HR11T1	51305 V/HR11Q1
	52	18	0,9	0,72	350	51	26	1	1	35,5	51305 V/HR22T2	51305 V/HR22Q2

¹⁾ Valid for bearings with stainless steel balls.

²⁾ Above 50 °C (120 °F) and/or above 20% of limiting speed consider reduction according to **diagram 1** (→ page 1256).

³⁾ Above 50 °C (120 °F) consider reduction according to **diagram 1** (→ page 1256).

Principal dimensions			Basic load ratings ²⁾		Limiting speed	Dimensions				Mass ¹⁾	Designations Bearing with stainless steel balls glass balls	
d	D	H	C	static ³⁾ C ₀		d ₁	D ₁	r ₁ min.	r ₃ min.			
mm			kN		r/min	mm				g	-	
30	47	11	0,95	0,76	400	46	31	0,5	1	17,5		51106 V/HR11T1 51106 V/HR11Q1
	47	11	0,835	0,67	370	46	31	0,5	1	13		51106 V/HR22T2 51106 V/HR22Q2
	52	16	1,025	0,82	375	51	31	1	1	34		51206 V/HR11T1 51206 V/HR11Q1
	52	16	0,9	0,72	345	51	31	1	1	25,5		51206 V/HR22T2 51206 V/HR22Q2
	60	21	1,07	0,86	360	59	31	1	1	63		51306 V/HR11T1 51306 V/HR11Q1
	60	21	0,94	0,755	330	59	31	1	1	47		51306 V/HR22T2 51306 V/HR22Q2
35	52	12	1,01	0,81	390	51	36	0,5	1	21		51107 V/HR11T1 51107 V/HR11Q1
	52	12	0,885	0,71	360	51	36	0,5	1	15,5		51107 V/HR22T2 51107 V/HR22Q2
	62	18	1,09	0,87	365	61	36	1	1	57		51207 V/HR11T1 51207 V/HR11Q1
	62	18	0,96	0,765	335	61	36	1	1	43,5		51207 V/HR22T2 51207 V/HR22Q2
40	60	13	1,11	0,89	375	59	41	0,5	1	29,5		51108 V/HR11T1 51108 V/HR11Q1
	60	13	0,975	0,78	345	59	41	0,5	1	22,5		51108 V/HR22T2 51108 V/HR22Q2
45	65	14	1,185	0,95	360	64	46	1	1	39		51109 V/HR11T1 51109 V/HR11Q1
	65	14	1,04	0,835	330	64	46	1	1	27,5		51109 V/HR22T2 51109 V/HR22Q2

¹⁾ Valid for bearings with stainless steel balls.

²⁾ Above 50 °C (120 °F) and/or above 20% of limiting speed consider reduction according to **diagram 1** (→ page 1256).

³⁾ Above 50 °C (120 °F) consider reduction according to **diagram 1** (→ page 1256).



SKF

16 Bearing accessories

Adapter sleeves	1270
Designs and variants	1270
Basic design	1270
Variants for oil injection	1270
Variants for CARB toroidal roller bearings	1273
Variants for sealed bearings	1273
Product data	1274
(Dimension standards, tolerances, external taper, thread, shaft tolerances)	
Withdrawal sleeves	1275
Designs and variants	1276
Basic design	1276
Variant for oil injection	1276
Product data	1277
(Dimension standards, tolerances, external taper, thread, shaft tolerances)	
Lock nuts	1278
Designs and variants	1278
Lock nuts with a lock washer, locking clip or locking plate	1278
Lock nuts with an integral locking device	1280
Lock nuts with a locking screw	1280
Precision lock nuts with locking pins	1281
Precision lock nuts with axial locking screws	1282
Product data	1285
(Dimension standards, tolerances, mating shaft threads, loosening torque)	
Installation and removal	1286
HM(E) and N lock nuts with a locking clip or locking plate	1286
KMK and KMFE lock nuts	1286
KMT and KMTA precision lock nuts	1286
KMD precision lock nuts	1287
Designation system	1288

Product tables

16.1 Adapter sleeves for metric shafts	1290
16.2 Adapter sleeves for inch shafts	1298
16.3 Adapter sleeves with inch dimensions	1304
16.4 Withdrawal sleeves	1310
16.5 KM(L) and HM.. T lock nuts	1316
16.6 MB(L) lock washers	1318
16.7 HM(E) lock nuts	1320
16.8 MS locking clips	1324
16.9 N and AN inch lock nuts	1326
16.10 W inch lock washers	1330
16.11 PL inch locking plates	1332
16.12 KMK lock nuts with an integral locking device	1333
16.13 KMFE lock nuts with a locking screw	1334
16.14 KMT precision lock nuts with locking pins	1336
16.15 KMTA precision lock nuts with locking pins	1338
16.16 KMD precision lock nuts with axial locking screws	1340



Adapter sleeves

Adapter sleeves are the most commonly used components for locating bearings with a tapered bore onto a cylindrical seat as they can be used on plain or stepped shafts (→ **fig. 1**). They are easy to install and require no additional location on the shaft. When adapter sleeves are used on plain shafts, the bearing can be located at any position on the shaft. When used on stepped shafts together with an L-shaped spacer ring, bearings can be accurately positioned axially thereby facilitating bearing mounting and dismounting.

Designs and variants

Basic design

SKF supplies metric adapter sleeves with a metric or an inch bore and inch adapter sleeves. The sleeves are slit and supplied complete with a lock nut and locking device. Smaller sizes use a nut and a lock washer. Larger sizes use a nut and a locking clip or locking plate (→ **fig. 2**).

Metric sleeves with a bore diameter ≤ 180 mm (size ≤ 40) are phosphated. Larger metric sleeves and all inch sleeves are coated with a solventless rust inhibitor.

Adapter sleeves listed in this catalogue constitute the basic SKF assortment and are only part of the total assortment. For larger sizes (bore diameter $\geq 1\ 060$ mm) and variants not listed in the product tables, contact SKF.

More information

Design considerations 159

Mounting, dismounting and bearing care 271

Mounting instructions for individual bearings → skf.com/mount

SKF maintenance products → skf.com/mapro

Variants for oil injection

Adapter sleeves with oil supply ducts and distribution grooves are available to enable use of the oil injection method to mount and dismount bearings (OH, OSNW and OSNP series, → **figs. 3 to 6, pages 1271 and 1272**).

Thread details for the oil supply ducts and the appropriate hydraulic nut designations are listed in the product tables. For information about oil injection equipment, refer to the catalogue *SKF Maintenance and Lubrication Products* or visit skf.com/mapro.

Fig. 1

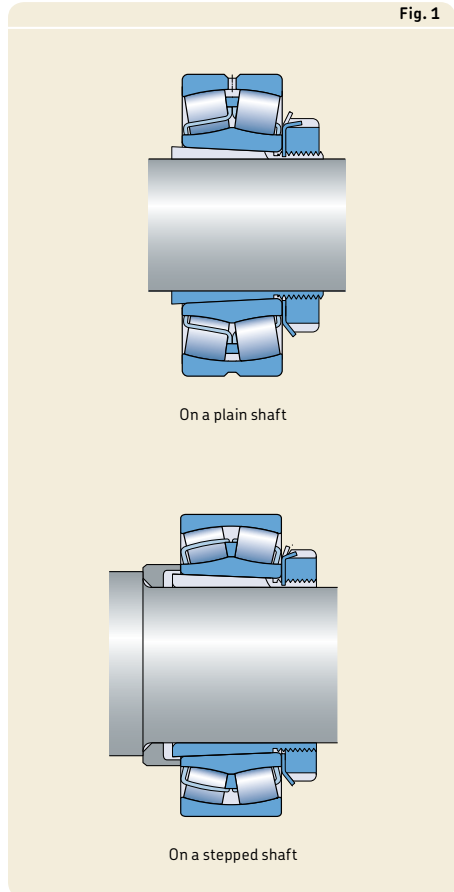
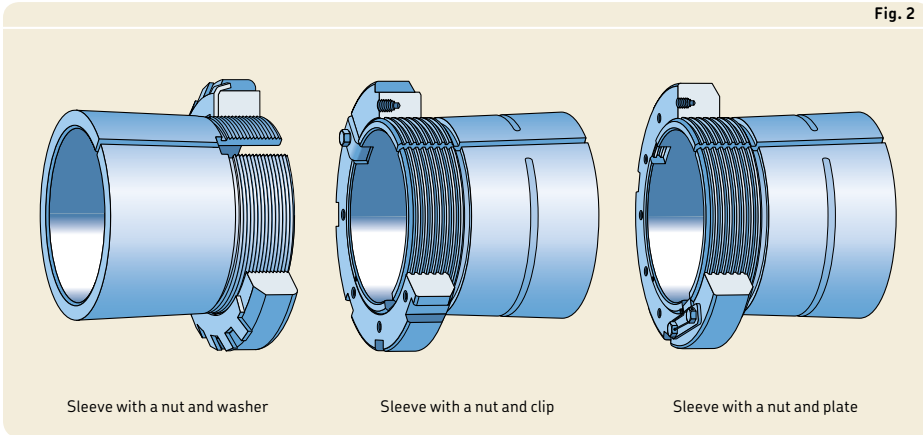

Fig. 2



Metric sleeves with a bore diameter ≥ 200 mm (size ≥ 44) are equipped with the necessary ducts and grooves as standard. For metric sleeves with a bore diameter ≥ 140 mm (size ≥ 32) and inch sleeves with a bore diameter $\geq 4 \frac{5}{16}$ in. (size ≥ 26), these features are available on request.

SKF manufactures oil injection sleeves in four variants that differ in the number and arrangement of the oil supply ducts and distribution grooves:

- designation suffix H (→ fig. 3)
These are the SKF standard adapter sleeves for oil injection. These sleeves have an oil supply duct at the threaded end of the sleeve and a distribution groove on the outside surface.
- no designation suffix (→ fig. 4)
These sleeves have an oil supply duct at the end opposite the threaded section and a distribution groove on the outside surface.

Fig. 3

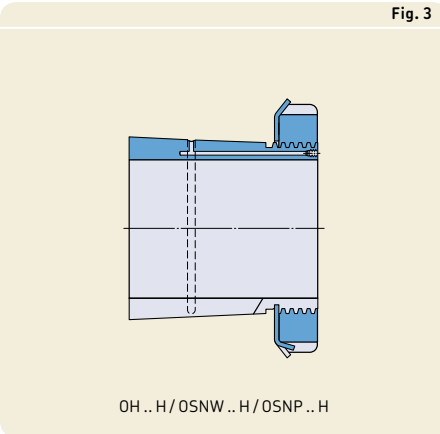
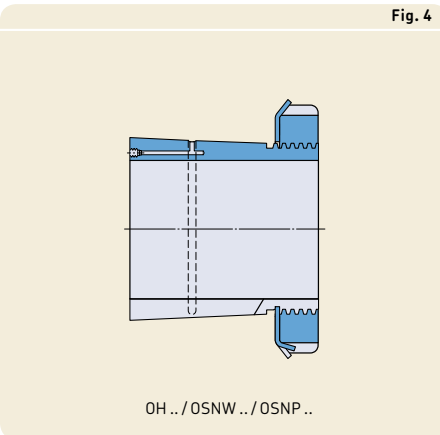

Fig. 4



16 Bearing accessories

- designation suffix B (→ **fig. 5**)
These sleeves have one or two oil supply ducts at the end opposite the threaded section and a distribution groove in the bore and on the outside surface. Metric and inch sleeves with a bore diameter < 200 mm (size ≤ 40) have one supply duct. Larger metric sleeves have two. Larger inch sleeves are made to order and can be supplied with one or two supply ducts on request. When sleeves have two supply ducts, each duct feeds one of the distribution grooves. An arrow on the sleeve side face, next to the duct inlet, indicates which groove the duct feeds.
- designation suffix HB (→ **fig. 6**)
These sleeves have one or two oil supply ducts at the threaded end of the sleeve and a distribution groove in the bore and on the outside surface. Metric and inch sleeves with a bore diameter < 200 mm (size ≤ 40) have one supply duct. Larger metric sleeves have two. Larger inch sleeves are made to order and can be supplied with one or two supply ducts on request. When sleeves have two supply ducts, each duct feeds one of the distribution grooves. An arrow on the sleeve side face, next to the duct inlet, indicates which groove the duct feeds.

Fig. 5

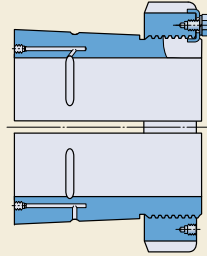

OH..B/OSNW..B/OSNP..B

Fig. 6

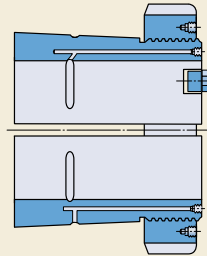

OH..HB/OSNW..HB/OSNP..HB

Fig. 7

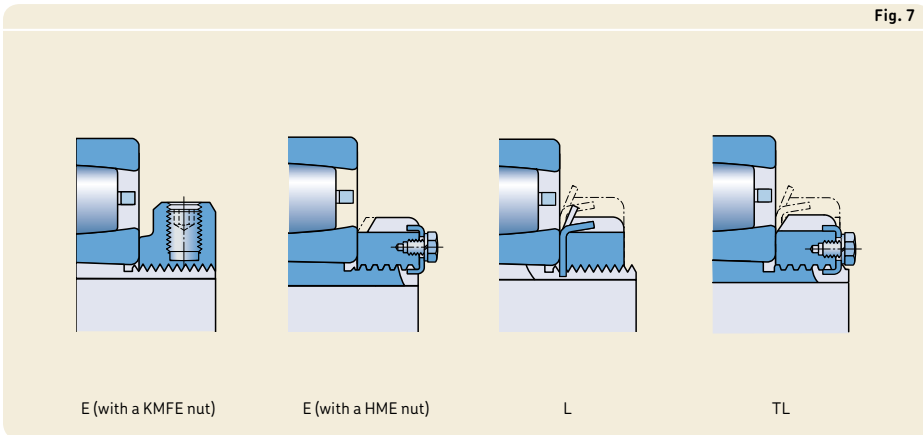

Variants for CARB toroidal roller bearings

Modified adapter sleeve assemblies with designation suffixes E, L and TL (→ **fig. 7**) are typically available for CARB bearings to prevent the locking device from interfering with the cage:

- Sleeves with a designation suffix E
 - The standard KM lock nut and MB lock washer are replaced with a KMFE lock nut.
 - The standard HM 30 or HM 31 lock nut is replaced with an HME lock nut.
- Sleeves with a designation suffix L
 - The standard KM lock nut and MB lock washer are replaced with a KML lock nut and MBL lock washer because both have a lower sectional height.
- Sleeves with a designation suffix TL
 - The standard HM .. T lock nut and MB lock washer are replaced with an HM 30 lock nut and an MS 30 locking clip because both have a lower sectional height.

When using CARB bearings on an adapter sleeve, check that there is sufficient space between the locking device and bearing to accommodate axial displacement (→ *Axial displacement*, **page 968**).

Variants for sealed bearings

Modified adapter sleeve assemblies with designation suffixes E, EL, EH, L and TL are typically available for sealed spherical roller bearings and sealed self-aligning ball bearings to prevent the locking device from interfering with the seal (→ **fig. 7** for designation suffixes E, L and TL). Adapter sleeve assemblies with a designation suffix EL or EH use either a KMFE .. L lock nut, which has a lower abutment diameter than the standard KMFE lock nut (→ **fig. 8**), or a KMFE .. H lock nut (→ **fig. 8**), which has a higher abutment diameter than the standard KMFE lock nut.

Fig. 8

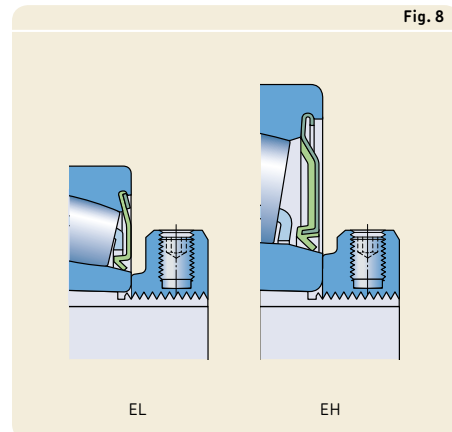

16 Bearing accessories

Product data		
	Metric series	Inch series
Dimension standards	ISO 2982-1, except for the bore diameter of sleeves for inch shafts	ANSI/ABMA Std. 8.2
Tolerances	Bore diameter: JS9 Width: h15	
External taper	1:12 as standard 1:30 as standard in the 40 and 41 dimension series For additional information, contact the SKF application engineering service.	
Thread	<p>Bore diameter < 200 mm (size ≤ 40): metric thread in accordance with ISO 965-3, matching the appertaining SKF lock nut</p> <p>Bore diameter ≥ 200 mm (size ≥ 44): metric trapezoidal thread in accordance with ISO 2903, matching the appertaining SKF lock nut</p>	<p>Bore diameter ≤ 12 in. (size ≤ 64): ANSI/ABMA B1.1 Unified Form Special</p> <p>Bore diameter ≥ 12 7/16 in. (size ≥ 68): ACME thread class 3G</p>
Shaft tolerances	<p>h9[Ⓔ] Cylindricity: IT5/2 – ISO 1101</p> <p>Adapter sleeves adapt to the shaft diameter, so that wider diameter tolerances can be permitted compared to the seat of a bearing with a cylindrical bore. However, the form tolerances must be kept within narrow limits as the accuracy of form directly affects the running accuracy of the bearing.</p>	

Withdrawal sleeves

Withdrawal sleeves can be used to mount bearings with a tapered bore on the cylindrical seat of stepped shafts (→ **fig. 9**). The sleeve is pressed into the bore of the bearing inner ring, which abuts a shaft shoulder or similar fixed component. The sleeve is located on the shaft by a nut or an end plate. Lock nuts or end plates are not supplied with withdrawal sleeves. KM or HM lock nuts (→ **page 1278**) with appropriate locking devices are suitable, but must be ordered separately.

To press the withdrawal sleeve into the bearing bore, a considerable amount of force is required to overcome the friction between the bearing, sleeve and shaft. To facilitate mounting and dismounting bearings on withdrawal sleeves, SKF recommends using a hydraulic nut (→ **fig. 10**).

Fig. 9

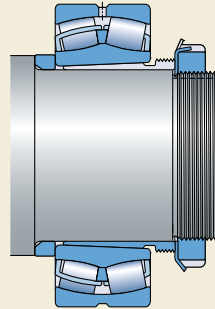
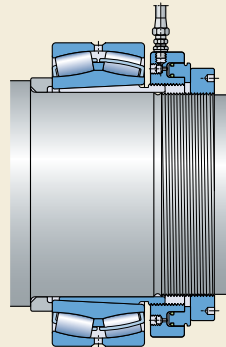

Fig. 10



16 Bearing accessories

Designs and variants

Basic design

SKF withdrawal sleeves (→ **fig. 11**) are slit. Sleeves with a bore diameter ≤ 190 mm (size ≤ 40) are phosphated. Larger sleeves are coated with a solventless rust inhibitor.

The nut required to dismount a withdrawal sleeve must be ordered separately. Appropriate sizes of nuts are listed in the product tables.

Withdrawal sleeves listed in this catalogue constitute the basic SKF assortment. For larger sizes (bore diameter $\geq 1\,060$ mm), contact SKF.

Variant for oil injection

Withdrawal sleeves with oil supply ducts and distribution grooves, which enable use of the oil injection method to mount and dismount bearings (AOH series, → **fig. 12**), are available. These sleeves have two oil supply ducts at the threaded end that feed the distribution grooves. The distribution grooves are in the circumferential and axial directions, on both the outside surface and the sleeve bore. Thread details for the oil supply ducts are listed in the product tables.

SKF withdrawal sleeves with a bore diameter ≥ 200 mm (size ≥ 44) are equipped with the necessary ducts and grooves as standard. For sleeves with a bore diameter ≥ 150 mm (size ≥ 32), these features are available on request.

For information about oil injection equipment, refer to the catalogue *SKF Maintenance and Lubrication Products* or visit skf.com/mapro.

Fig. 11

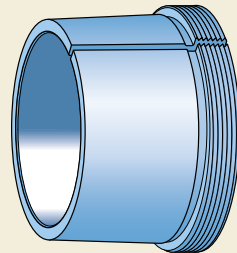
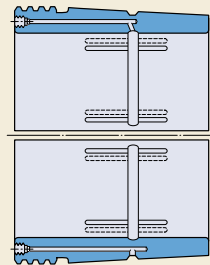

Fig. 12



AOH

Product data	
Dimension standards	ISO 2982-1
Tolerances	Bore diameter: JS9 Width: h13
External taper	1:12 as standard 1:30 as standard in the A(O)H 240 and A(O)H 241 series
Thread	<p>Bore diameter \leq 180 mm (size \leq 38): metric thread in accordance with ISO 965-3, matching the appropriate SKF nut for dismounting</p> <p>Bore diameter \geq 190 mm (size \geq 40): metric trapezoidal thread in accordance with ISO 2903, matching the appropriate SKF nut for dismounting</p> <hr/> <p>Thread requirements for other lock nuts than listed in the product tables:</p> <p>Bore diameter \leq 180 mm (size \leq 38): Tolerance 5H – ISO 965-3</p> <p>Bore diameter \geq 190 mm (size \geq 40): Tolerance 7H – ISO 2903</p>
Shaft tolerances	<p>h9[Ⓔ]</p> <p>Cylindricity: IT5/2 – ISO 1101</p> <p>Withdrawal sleeves adapt to the shaft diameter, so that wider diameter tolerances can be permitted compared to the seat of a bearing with a cylindrical bore. However, the form tolerances must be kept within narrow limits as the accuracy of form directly affects the running accuracy of the bearing.</p>

Lock nuts

Lock nuts are used to locate bearings and other components onto a shaft or adapter sleeve. They are also used for mounting bearings on tapered shaft seats and dismantling bearings from withdrawal sleeves. Lock nuts have to be secured to prevent unintentional loosening. This is done, either by a locking device that engages a keyway in the shaft or key slot in the adapter sleeve, or by a locking mechanism integrated in the nut. Lock nuts with an integrated locking mechanism reduce the cost of the shaft as no keyway is required. Installation is also quicker and easier because no separate locking device is necessary. However, the loosening torque of these lock nuts requires more attention (→ page 1284).

Designs and variants

SKF lock nuts provide a variety of ways to secure the nut onto the shaft. The lock nuts listed in this catalogue constitute the basic SKF assortment. Lock nuts with other locking methods can be supplied on request. For additional information, contact the SKF application engineering service.

Lock nuts with a lock washer, locking clip or locking plate

These lock nuts are available in different series (→ fig. 13):

- KM and KML lock nuts have metric threads and use lock washers (→ fig. 14).
- HM .. T lock nuts have metric trapezoidal threads and use lock washers (→ fig. 14). For some sizes no lock washer is available, because these nuts are intended only for removal purposes.
- HM and HME lock nuts have metric trapezoidal threads and use locking clips (→ fig. 15).
- N and AN lock nuts have inch dimensions. Lock nuts with thread diameters $\leq 8 \frac{5}{8}$ in. (size ≤ 44) use a lock washer (→ fig. 14). Lock nuts with thread diameters $\geq 9 \frac{7}{16}$ in. (size ≥ 48) use a locking plate (→ fig. 16).

Lock washers, locking clips and locking plates are simple, stable and reliable fastening elements which engage a keyway in the shaft or key slot in the adapter sleeve. The washer locks the nut in position when one of the washer tabs is bent into one of the slots on the nut (→ fig. 17). Locking clips and locking plates are attached to the nut by bolts (→ figs. 18 and 19).

A locking clip consists of the clip, a hexagonal head bolt in accordance with EN ISO 4017 and a spring-lock washer in accordance with DIN 128 (→ fig. 15). A locking plate consists of the plate, two hexagonal head bolts and a wire (→ fig. 16).

The nut and the locking device must be ordered separately. The appropriate locking device is listed in the product tables. KM lock nuts can be locked either with the MB lock

Fig. 13

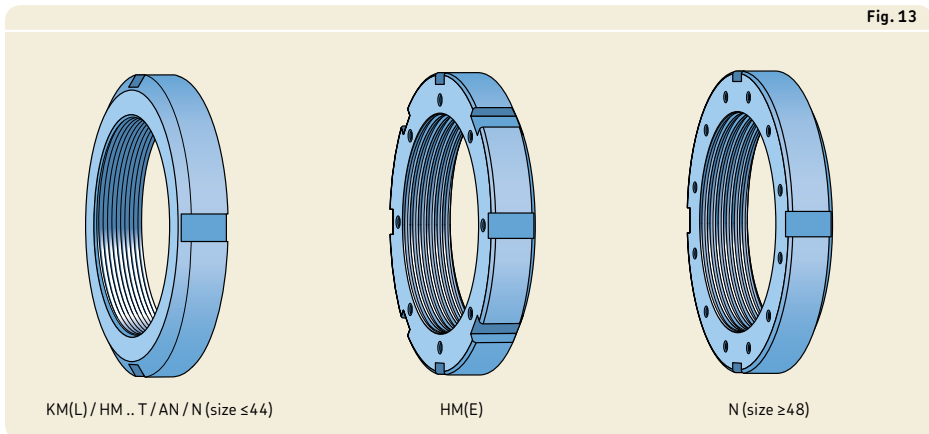
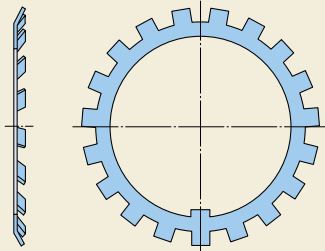
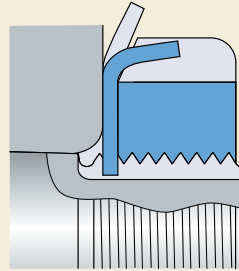

Fig. 14



MB / W lock washer

Fig. 17



Locking with a washer

Fig. 15

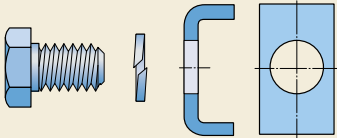

MS locking clip

Fig. 18

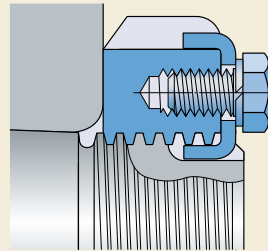

Locking with a clip

Fig. 16

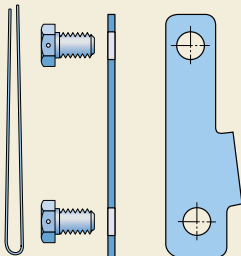

PL locking plate

Fig. 19

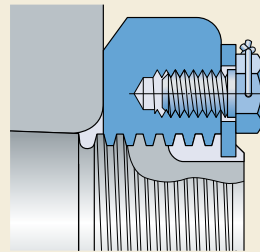

Locking with a plate

16 Bearing accessories

washer listed in the product tables or with a stronger, MB .. A lock washer (→ **product table, page 1318**).

Lock nuts with an integral locking device

KMK series lock nuts (→ **fig. 20**) have a threaded steel insert in their bore to lock the nut in place on the shaft or adapter sleeve. The threads on the insert match the locknut threads. The insert acts as a pressure plate when a grub screw, which runs through the body of the lock nut, is tightened. (→ **fig. 21**). KMK lock nuts are intended to locate radial bearings in less demanding applications.

KMK lock nuts should not be used on shafts with a keyway or on adapter sleeves with a key

slot. The locking device can be damaged if it aligns with a keyway or slot.

Lock nuts with a locking screw

KMFE series lock nuts (→ **fig. 22**) use an integral grub screw (locking screw) to press the threads on the nut against the threads on a shaft (→ **fig. 23**) or sleeve. Lock nuts in the KMFE series are intended to axially locate CARB toroidal roller bearings, sealed spherical roller bearings and sealed self-aligning ball bearings on a shaft or an adapter sleeve.

KMFE lock nuts should not be used on shafts with a keyway or on adapter sleeves with a key slot. The locking screw can damage the nut if the screw aligns with a keyway or slot.

Fig. 20

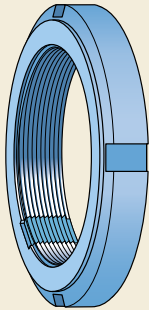

KMK

Fig. 22

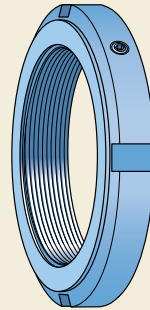

KMFE

Fig. 21

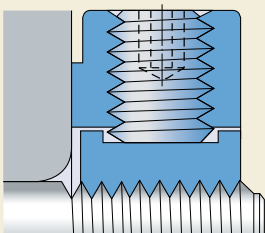
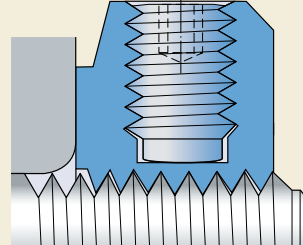

Fig. 23



Precision lock nuts with locking pins

KMT and KMTA series precision lock nuts (→ **fig. 24**) have three locking pins equally spaced around the circumference of the nut to lock it onto the shaft. The locking pins are pressed into the shaft thread with grub screws. The end face of each pin is machined to match the shaft thread (→ **fig. 25**). The holes for the locking pins and grub screws are drilled at an angle to the shaft thread to avoid backlash.

SKF KMT and KMTA series precision lock nuts are intended for applications where high precision, simple assembly and reliable locking are required. They should not be used on shafts with a keyway or on adapter sleeves with a key slot. The locking pin can be damaged if it aligns with a keyway or slot.

KMT lock nuts with a thread ranging from 260 to 420 mm (sizes 52 to 84) can be supplied on request. For additional information, contact the SKF application engineering service.

KMTA lock nuts have a full cylindrical outside surface and a different thread pitch than KMT nuts for some sizes. They are intended primarily for applications where space is limited. The nut can be used to establish a gap-type seal.

Fig. 25

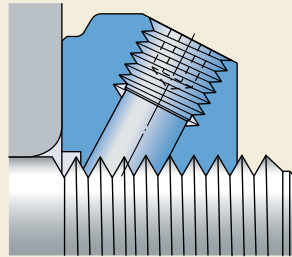
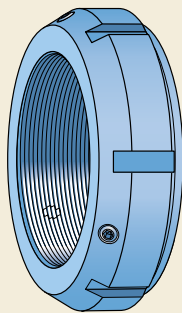
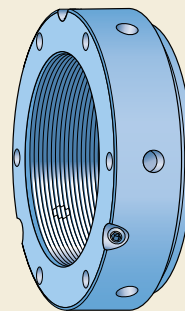

Fig. 24



KMT



KMTA

16 Bearing accessories

Precision lock nuts with axial locking screws

Precision lock nuts in the KMD series (→ **fig. 26**) are two-piece nuts connected by axial locking screws. Once the lock nut is in place against the component, the locking screws are tightened. This pulls the rear threads forward, locking the nut in place (→ **fig. 27**).

Fig. 26

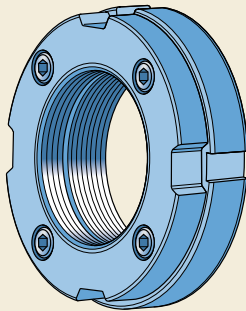

KMD

Fig. 27

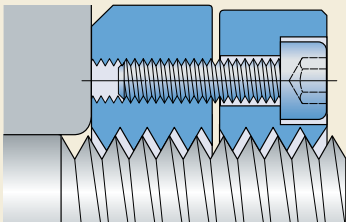

Product data		
	<p>Lock nuts with a lock washer or a locking clip (locking plate)</p>	
	Metric series, KM(L) and HM(E)	Inch series, N and AN
Dimension standards	ISO 2982-2	ANSI/ABMA Std. 8.2
Tolerances	<p>KM(L): metric thread 5H: ISO 965-3 Axial run-out locating face / thread: 0,04 to 0,06 mm max., depending on the lock nut size</p> <p>HM(E) and HM .. T: metric trapezoidal thread 7H: ISO 2903 Axial run-out locating face / thread: 0,06 to 0,16 mm max., depending on the lock nut size</p>	<p>ANSI/ABMA Std. 8.2</p> <p>Axial run-out locating face / thread: 0,05 to 0,30 mm (0.002 to 0.012 in.) max., depending on the lock nut size</p>
Mating shaft threads (Recommendation)	<p>Metric thread: Tolerance 6g – ISO 965-3</p> <p>Metric trapezoidal thread: Tolerance 7e – ISO 2903</p>	ANSI/ABMA Std. 8.2
Loosening torque	–	
<p>For additional information, contact the SKF application engineering service.</p>		

with an integral locking device KMK series	with a locking screw KMFE series	Precision lock nuts with locking pins KMT(A) series	with axial locking screws KMD series
ISO 2982-2, except for the width Grub screw: ISO 4026, material class 45H		ISO 965-3	ISO 965-3 Locking screws: ISO 4762
Metric thread: 5H: ISO 965-3		Metric thread: 5H: ISO 965-3 Axial run-out locating face / thread: 0,005 mm max., when size ≤ 26	Metric thread: 5H: ISO 965-3 Axial run-out locating face / thread: 0,005 mm max.
Tolerance 6g: ISO 965-3		Tolerance 6g: ISO 965-3 Thread ≥ 220 mm (size ≥ 44): Trapezoidal thread tolerance 7e – ISO 2903	Tolerance 6g: ISO 965-3
Lock nuts are locked on the shaft (sleeve) by friction. The friction, and therefore the loosening torque, varies as a result of the accuracy of the tightening torque of the grub screw (locking screws), the surface finish of the shaft (sleeve) thread, the amount of lubricant on the thread, etc. The lock nuts should be properly mounted and there should be only a limited amount of lubricant on the thread.			
Sufficient locking for intended bearing applications. Full locking effect is obtained when the nut is not pressed against the locked component.	Sufficient locking for intended bearing applications.	Sufficient locking for precision and general bearing applications.	

Installation and removal

Except for KMTA lock nuts, all SKF lock nuts have slots around their circumference to accommodate a hook or impact spanner. The designations of the appropriate spanners are listed in the product tables. For additional information about spanners, refer to the catalogue *SKF Maintenance and Lubrication Products* or visit skf.com/mapro.

KMTA lock nuts have holes around their circumference and in one side face. They can be tightened with a pin wrench, a pin-type face spanner or a tommy bar. Appropriate spanners in accordance with DIN 1810 are listed in the product tables.

In addition to the slots, KMT lock nuts with a thread ≤ 75 mm (size ≤ 15) have two opposed flats to accommodate a spanner.

All SKF lock nuts can be reused, provided they are not damaged. A new lock washer, locking clip or locking plate should be used each time the corresponding lock nut is installed. KMT(A) and KMD lock nuts are designed for frequent installation and removal.

HM(E) and N lock nuts with a locking clip or locking plate

The bolts of the locking clips or locking plates must be secured to prevent them from turning. Locking clips are supplied with a spring-lock washer, which must be placed between the bolt and clip. The wire supplied with the locking plate should be put through the holes in the bolt heads and tightened.

KMK and KMFE lock nuts

A hexagonal wrench is needed to tighten KMK grub screws and KMFE locking screws. Screw sizes are listed in the product tables. The screws should be tightened to the torque value listed in the product tables.

KMT and KMTA precision lock nuts

Locking

KMT and KMTA precision lock nuts should be locked in two phases:

- 1 Tighten the grub screws carefully until the locking pin engages the shaft thread.
- 2 Alternately tighten the grub screws with a torque wrench until the recommended torque value is achieved (→ **product tables**).

Adjusting

KMT and KMTA series precision lock nuts are adjustable. The three equally spaced locking pins enable the nut to be accurately positioned at right angles to the shaft or they can be used to adjust for misalignment between the abutment surface and the adjacent component. Adjustments can be made using the following procedure:

- 1 Loosen the grub screw at the position showing the greatest deviation.
- 2 Tighten the two remaining screws equally.
- 3 Retighten the screw that was loosened.
- 4 Check the accuracy of the installation with a dial gauge.
- 5 Repeat the procedure if the result is not adequate.

Removal

When removing KMT and KMTA lock nuts, the locking pins can still engage the shaft thread even after the grub screws have been loosened. Using a rubber hammer, tap the nut lightly in the vicinity of the pins to disengage the pins from the shaft.

KMD precision lock nuts

KMD lock nuts are supplied with the locking screws gently tightened and with a protector between the front and rear part of the lock nut. KMD lock nuts should be installed according to the following procedure:

- 1** Loosen the locking screws half a turn.
Do not remove them.
- 2** Remove the protector between the two halves of the lock nut.
- 3** Press the front and rear halves together and screw the lock nut onto the shaft thread. When the rear half grabs onto the shaft thread, a gap occurs between the two parts.
- 4** Screw the lock nut to its final position on the shaft thread. When tightening the lock nut, put the spanner in the slots on the front half of the nut.
- 5** Alternately tighten the locking screws in a criss-cross pattern until the recommended torque value is obtained (→ **product tables**). Use a hexagonal wrench to tighten the locking screws. Screw sizes are listed in the product tables.

For precision positioning, screw the lock nut to the approximate position on the shaft and tighten the locking screws to half of the recommended tightening torque. Then screw the nut to its final position and fully tighten the locking screws.

Designation system

Product type

Sleeves

H	Adapter sleeve dimensions in accordance with ISO standard, basic design
HA	Adapter sleeve dimensions in accordance with ISO standard, except the bore, in $1/16$ in.
HE	Adapter sleeve dimensions in accordance with ISO standard, except the bore, in $1/4$ in.
HS	Adapter sleeve dimensions in accordance with ISO standard, except the bore, in $1/8$ in.
OH	Adapter sleeve dimensions in accordance with ISO standard, prepared for oil injection
OSNP	Adapter sleeve dimensions in accordance with ANSI standard, prepared for oil injection, with a locking plate
OSNW	Adapter sleeve dimensions in accordance with ANSI standard, prepared for oil injection, with a lock washer
SNP	Adapter sleeve dimensions in accordance with ANSI standard, with a locking plate
SNW	Adapter sleeve dimensions in accordance with ANSI standard, with a lock washer
AH	Withdrawal sleeve dimensions in accordance with ISO standard, basic design
AHX	Withdrawal sleeve dimensions in accordance with ISO standard, basic design
AOH	Withdrawal sleeve dimensions in accordance with ISO standard, prepared for oil injection
AOHX	Withdrawal sleeve dimensions in accordance with ISO standard, prepared for oil injection
KH	Unthreaded sleeve, basic design
KOH	Unthreaded sleeve, prepared for oil injection

Lock nuts and locking devices

AN	Lock nut dimensions in accordance with ANSI standard
HM	Lock nut with a trapezoidal thread
HME	HM lock nut with a recessed outside diameter
HML	HM lock nut, light series
HMLL	HML lock nut with a lower sectional height
KM	Lock nut dimensions in accordance with ISO standard
KMD	Two part precision lock nut with axial locking screws
KMFE	Lock nut with a locking screw, with an extended nose
KMK	Lock nut with an integral locking device
KML	Lock nut with a lower sectional height
KMT	Precision lock nut with locking pins
KMTA	Precision lock nut with locking pins, different thread pitch
N	Lock nut dimensions in accordance with ANSI standard
N 0	Lock nut dimensions in accordance with ANSI standard, light section
MB	Lock washer dimensions in accordance with ISO standard, for a KM lock nut
MBL	Lock washer dimensions in accordance with ISO standard, for a KML lock nut
MS 30	Locking clip dimensions in accordance with ISO standard, for an HM 30 lock nut
MS 31	Locking clip dimensions in accordance with ISO standard, for an HM 31 lock nut
PL	Locking plate dimensions in accordance with ANSI standard
W	Lock washer for N or AN lock nut, with an axial tab, dimension in accordance with ANSI standard
W 0	Lock washer for N 0 lock nut (light series), without an axial tab, dimensions in accordance with ANSI standard



Suffix

Sleeves

- B** One or two oil supply ducts at the end opposite the threaded section
- D** Split sleeve
- E** Adapter sleeve without key slot, with a KMFE lock nut or standard adapter sleeve with a HME lock nut
- EH** Adapter sleeve without key slot, with a KMFE .. H lock nut
- EL** Adapter sleeve without key slot, with a KMFE .. L lock nut
- G** Thread diameter changed according to revised ISO standard
- H** One oil supply duct at the threaded end
- HB** One or two oil supply ducts at the threaded end
- L** Adapter sleeve with a lock nut with lower sectional height
- TL** Same as L, but with key slot positions for a locking clip

Lock nuts and locking devices

- B** Whitworth thread
- H** KMFE lock nut with a bigger contact diameter
- L** KMFE lock nut with a smaller contact diameter
- P** Sintered material
- T** Trapezoidal thread
- A** Increased plate thickness for MB lock washers

Size identification

Listed in the product tables

16.1 Adapter sleeves for metric shafts

d_1 17 – 100 mm

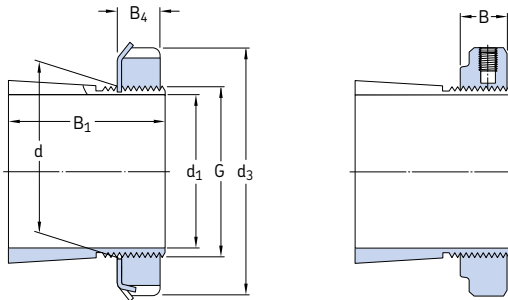

H

H.. E, H.. EL

Principal dimensions						Mass	Designations	Appertaining	locking device	Appro-
d_1	d	d_3	B_1	B, B_4	G		Adapter sleeve	lock nut		prate
mm	mm	mm	mm	mm	mm	kg	with nut and			hydraulic
							locking device			nut
17	20	32	24	7	M 20x1	0,036	H 204	KM 4	MB 4	–
	20	32	28	7	M 20x1	0,04	H 304	KM 4	MB 4	–
	20	32	28	9,5	M 20x1	0,047	H 304 E	KMFE 4	–	–
20	25	38	26	8	M 25x1,5	0,064	H 205	KM 5	MB 5	–
	25	38	29	8	M 25x1,5	0,071	H 305	KM 5	MB 5	–
	25	38	29	10,5	M 25x1,5	0,076	H 305 E	KMFE 5	–	–
	25	38	35	8	M 25x1,5	0,085	H 2305	KM 5	MB 5	–
25	30	45	27	8	M 30x1,5	0,086	H 206	KM 6	MB 6	–
	30	45	31	8	M 30x1,5	0,095	H 306	KM 6	MB 6	–
	30	45	31	10,5	M 30x1,5	0,11	H 306 E	KMFE 6	–	–
	30	45	38	8	M 30x1,5	0,11	H 2306	KM 6	MB 6	–
30	35	52	29	9	M 35x1,5	0,12	H 207	KM 7	MB 7	–
	35	52	35	9	M 35x1,5	0,14	H 307	KM 7	MB 7	–
	35	52	35	11,5	M 35x1,5	0,15	H 307 E	KMFE 7	–	–
	35	52	35	11,5	M 35x1,5	0,16	H 307 EL	KMFE 7 L	–	–
	35	52	43	9	M 35x1,5	0,16	H 2307	KM 7	MB 7	–
35	40	58	31	10	M 40x1,5	0,16	H 208	KM 8	MB 8	–
	40	58	36	10	M 40x1,5	0,17	H 308	KM 8	MB 8	–
	40	58	36	13	M 40x1,5	0,19	H 308 E	KMFE 8	–	–
	40	58	46	10	M 40x1,5	0,22	H 2308	KM 8	MB 8	–
	40	58	46	13	M 40x1,5	0,24	H 2308 E	KMFE 8	–	–
40	45	65	33	11	M 45x1,5	0,21	H 209	KM 9	MB 9	–
	45	65	39	11	M 45x1,5	0,23	H 309	KM 9	MB 9	–
	45	65	39	13	M 45x1,5	0,24	H 309 E	KMFE 9	–	–
	45	65	50	11	M 45x1,5	0,27	H 2309	KM 9	MB 9	–
45	50	70	35	12	M 50x1,5	0,24	H 210	KM 10	MB 10	HMV 10E
	50	70	42	12	M 50x1,5	0,27	H 310	KM 10	MB 10	HMV 10E
	50	70	42	14	M 50x1,5	0,3	H 310 E	KMFE 10	–	HMV 10E
	50	70	55	12	M 50x1,5	0,34	H 2310	KM 10	MB 10	HMV 10E
50	55	75	37	12,5	M 55x2	0,28	H 211	KM 11	MB 11	HMV 11E
	55	75	45	12,5	M 55x2	0,32	H 311	KM 11	MB 11	HMV 11E
	55	75	45	14	M 55x2	0,34	H 311 E	KMFE 11	–	HMV 11E
	55	75	59	12,5	M 55x2	0,39	H 2311	KM 11	MB 11	HMV 11E

Principal dimensions						Mass	Designations	Appertaining	locking device	Appropriate hydraulic nut
d ₁	d	d ₃	B ₁	B, B ₄	G		Adapter sleeve with nut and locking device	lock nut		
mm						kg	–			
55	60	80	38	13	M 60x2	0,31	H 212	KM 12	MB 12	HMV 12E
	60	80	47	13	M 60x2	0,36	H 312	KM 12	MB 12	HMV 12E
	60	80	47	14	M 60x2	0,4	H 312 E	KMFE 12	–	HMV 12E
	60	80	62	13	M 60x2	0,45	H 2312	KM 12	MB 12	HMV 12E
60	65	85	40	13,5	M 65x2	0,36	H 213	KM 13	MB 13	HMV 13E
	65	85	50	13,5	M 65x2	0,42	H 313	KM 13	MB 13	HMV 13E
	65	85	50	15	M 65x2	0,43	H 313 E	KMFE 13	–	HMV 13E
	65	85	65	13,5	M 65x2	0,52	H 2313	KM 13	MB 13	HMV 13E
	65	85	65	15	M 65x2	0,53	H 2313 E	KMFE 13	–	HMV 13E
	70	92	52	13,5	M 70x2	0,67	H 314	KM 14	MB 14	HMV 14E
70	92	52	15	M 70x2	0,67	H 314 E	KMFE 14	–	HMV 14E	
70	92	68	13,5	M 70x2	0,88	H 2314	KM 14	MB 14	HMV 14E	
65	75	98	43	14,5	M 75x2	0,66	H 215	KM 15	MB 15	HMV 15E
	75	98	55	14,5	M 75x2	0,78	H 315	KM 15	MB 15	HMV 15E
	75	98	55	16	M 75x2	0,82	H 315 E	KMFE 15	–	HMV 15E
	75	98	73	14,5	M 75x2	1,1	H 2315	KM 15	MB 15	HMV 15E
70	80	105	46	17	M 80x2	0,81	H 216	KM 16	MB 16	HMV 16E
	80	105	59	17	M 80x2	0,95	H 316	KM 16	MB 16	HMV 16E
	80	105	59	18	M 80x2	1	H 316 E	KMFE 16	–	HMV 16E
	80	105	78	17	M 80x2	1,2	H 2316	KM 16	MB 16	HMV 16E
75	85	110	50	18	M 85x2	0,94	H 217	KM 17	MB 17	HMV 17E
	85	110	63	18	M 85x2	1,1	H 317	KM 17	MB 17	HMV 17E
	85	110	63	19	M 85x2	1,15	H 317 E	KMFE 17	–	HMV 17E
	85	110	82	18	M 85x2	1,35	H 2317	KM 17	MB 17	HMV 17E
80	90	120	52	18	M 90x2	1,1	H 218	KM 18	MB 18	HMV 18E
	90	120	65	18	M 90x2	1,3	H 318	KM 18	MB 18	HMV 18E
	90	120	65	19	M 90x2	1,45	H 318 E	KMFE 18	–	HMV 18E
	90	120	73	19	M 90x2	1,5	H 2318 E/L73¹⁾	KMFE 18	–	HMV 18E
	90	120	86	18	M 90x2	1,6	H 2318	KM 18	MB 18	HMV 18E
85	95	125	55	19	M 95x2	1,25	H 219	KM 19	MB 19	HMV 19E
	95	125	68	19	M 95x2	1,4	H 319	KM 19	MB 19	HMV 19E
	95	125	68	20	M 95x2	1,45	H 319 E	KMFE 19	–	HMV 19E
	95	125	90	19	M 95x2	1,8	H 2319	KM 19	MB 19	HMV 19E
	95	125	90	20	M 95x2	1,85	H 2319 EL	KMFE 19 L	–	HMV 19E
90	100	130	58	20	M 100x2	1,4	H 220	KM 20	MB 20	HMV 20E
	100	130	71	20	M 100x2	1,6	H 320	KM 20	MB 20	HMV 20E
	100	130	71	21	M 100x2	1,7	H 320 E	KMFE 20	–	HMV 20E
	100	130	76	20	M 100x2	1,8	H 3120	KM 20	MB 20	HMV 20E
	100	130	76	21	M 100x2	1,8	H 3120 E	KMFE 20	–	HMV 20E
	100	130	97	20	M 100x2	2	H 2320	KM 20	MB 20	HMV 20E
	100	130	97	21	M 100x2	2	H 2320 E	KMFE 20	–	HMV 20E
100	110	145	63	21	M 110x2	1,8	H 222	KM 22	MB 22	HMV 22E
	110	145	77	21	M 110x2	2,05	H 322	KM 22	MB 22	HMV 22E
	110	145	77	21,5	M 110x2	2,1	H 322 E	KMFE 22	–	HMV 22E
	110	145	81	21	M 110x2	2,1	H 3122	KM 22	MB 22	HMV 22E
	110	145	81	21,5	M 110x2	2,15	H 3122 E	KMFE 22	–	HMV 22E
	110	145	105	21	M 110x2	2,75	H 2322	KM 22	MB 22	HMV 22E
	110	145	105	21,5	M 110x2	2,75	H 2322 E	KMFE 22	–	HMV 22E

¹⁾ Width reduced to 73 mm

16.1 Adapter sleeves for metric shafts d₁ 110 – 180 mm

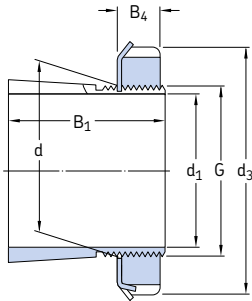

H, H..L

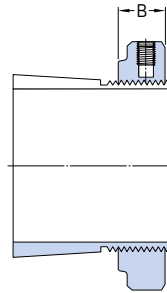

H..E, H..EH

Principal dimensions						Mass	Designations Adapter sleeve with nut and locking device	Appertaining lock nut	locking device	Appro- priate hydraulic nut
d ₁	d	d ₃	B ₁	B, B ₄	G					
mm						kg	-			
110	120	145	72	22	M120x2	1,8	H 3024	KML 24	MBL 24	HMV 24E
	120	145	88	22	M120x2	2,5	H 3124 L	KML 24	MBL 24	HMV 24E
	120	145	112	22	M120x2	3,1	H 2324 L	KML 24	MBL 24	HMV 24E
120	155	72	26	M120x2	1,85	H 3024 E	KMFE 24	-	HMV 24E	
	120	155	88	22	M120x2	2,5	H 3124	KM 24	MB 24	HMV 24E
	120	155	112	22	M120x2	3	H 2324	KM 24	MB 24	HMV 24E
	120	155	112	26	M120x2	3,1	H 2324 E	KMFE 24	-	HMV 24E
	120	155	112	26	M120x2	3,1	H 2324 EH	KMFE 24 H	-	HMV 24E
	130	155	80	23	M130x2	2,8	H 3026	KML 26	MBL 26	HMV 26E
115	130	155	92	23	M130x2	3,65	H 3126 L	KML 26	MBL 26	HMV 26E
	130	155	121	23	M130x2	4,15	H 2326 L	KML 26	MBL 26	HMV 26E
	130	165	80	28	M130x2	2,9	H 3026 E	KMFE 26	-	HMV 26E
	130	165	92	23	M130x2	3,45	H 3126	KM 26	MB 26	HMV 26E
	130	165	121	23	M130x2	4,45	H 2326	KM 26	MB 26	HMV 26E
	140	165	82	24	M140x2	3,05	H 3028	KML 28	MBL 28	HMV 28E
125	140	165	97	24	M140x2	4,1	H 3128 L	KML 28	MBL 28	HMV 28E
	140	180	82	28	M140x2	3,05	H 3028 E	KMFE 28	-	HMV 28E
	140	180	97	24	M140x2	4,1	H 3128	KM 28	MB 28	HMV 28E
	140	180	131	24	M140x2	5,4	H 2328	KM 28	MB 28	HMV 28E
	150	180	87	26	M150x2	3,75	H 3030	KML 30	MBL 30	HMV 30E
135	150	180	111	26	M150x2	4,7	H 3130 L	KML 30	MBL 30	HMV 30E
	150	180	139	26	M150x2	5,85	H 2330 L	KML 30	MBL 30	HMV 30E
	150	195	87	30	M150x2	3,75	H 3030 E	KMFE 30	-	HMV 30E
	150	195	111	26	M150x2	5,25	H 3130	KM 30	MB 30	HMV 30E
	150	195	111	30	M150x2	4,7	H 3130 E	KMFE 30	-	HMV 30E
	150	195	139	26	M150x2	6,4	H 2330	KM 30	MB 30	HMV 30E
140	160	190	93	27,5	M160x3	5,1	H 3032	KML 32	MBL 32	HMV 32E
	160	190	119	27,5	M160x3	6,4	H 3132 L	KML 32	MBL 32	HMV 32E
	160	190	147	28	M160x3	7,95	H 2332 L	KML 32	MBL 32	HMV 32E
160	210	93	32	M160x3	5,1	H 3032 E	KMFE 32	-	HMV 32E	
	160	210	119	28	M160x3	7,25	H 3132	KM 32	MB 32	HMV 32E
	160	210	119	32	M160x3	7,35	H 3132 E	KMFE 32	-	HMV 32E
	160	210	147	28	M160x3	8,8	H 2332	KM 32	MB 32	HMV 32E

Principal dimensions						Mass	Designations	Appertaining	locking device	Appro-
d ₁	d	d ₃	B ₁	B, B ₄	G		Adapter sleeve with nut and locking device	lock nut		appropriate hydraulic nut
mm						kg	–			
150	170	200	101	28,5	M170x3	5,8	H 3034	KML 34	MBL 34	HMV 34E
	170	200	122	29	M170x3	7,15	H 3134 L	KML 34	MBL 34	HMV 34E
	170	220	101	33	M170x3	5,9	H 3034 E	KMFE 34	–	HMV 34E
	170	220	122	29	M170x3	8,1	H 3134	KM 34	MB 34	HMV 34E
	170	220	122	33	M170x3	8,1	H 3134 E	KMFE 34	–	HMV 34E
	170	220	154	29	M170x3	9,9	H 2334	KM 34	MB 34	HMV 34E
160	180	210	87	29,5	M180x3	5,7	H 3936	KML 36	MBL 36	HMV 36E
	180	210	109	29,5	M180x3	6,7	H 3036	KML 36	MBL 36	HMV 36E
	180	210	131	29,5	M180x3	8,15	H 3136 L	KML 36	MBL 36	HMV 36E
	180	230	109	34	M180x3	6,7	H 3036 E	KMFE 36	–	HMV 36E
	180	230	131	29,5	M180x3	9,15	H 3136	KM 36	MB 36	HMV 36E
	180	230	161	30	M180x3	11	H 2336	KM 36	MB 36	HMV 36E
170	190	220	89	30,5	M190x3	6,2	H 3938	KML 38	MBL 38	HMV 38E
	190	220	112	30,5	M190x3	7,25	H 3038	KML 38	MBL 38	HMV 38E
	190	240	141	30,5	M190x3	10,5	H 3138	KM 38	MB 38	HMV 38E
	190	240	169	30,5	M190x3	12	H 2338	KM 38	MB 38	HMV 38E
180	200	240	98	31,5	M200x3	7,9	H 3940	KML 40	MBL 40	HMV 40E
	200	240	120	31,5	M200x3	8,9	H 3040	KML 40	MBL 40	HMV 40E
	200	240	176	31,5	M200x3	13	H 2340 L	KML 40	MBL 40	HMV 40E
	200	250	150	31,5	M200x3	12	H 3140	KM 40	MB 40	HMV 40E
	200	250	176	31,5	M200x3	13,5	H 2340	KM 40	MB 40	HMV 40E

For oil injection variants not listed, contact SKF.

16.1 Adapter sleeves for metric shafts d₁ 200 – 500 mm

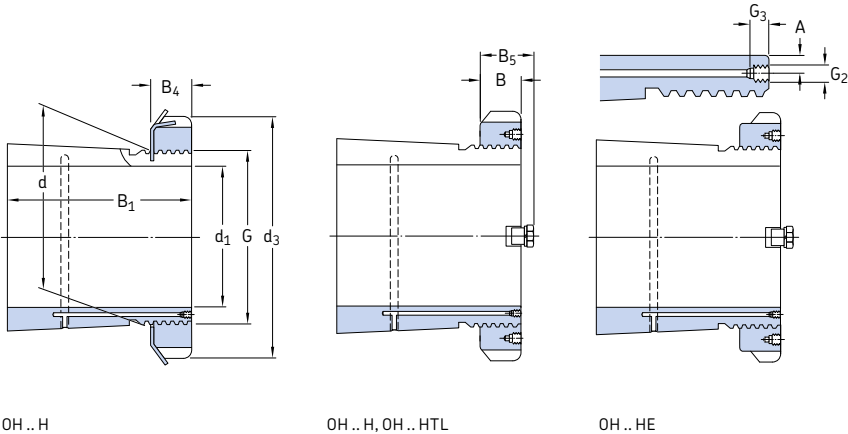

Principal dimensions							Mass		Designations		Appertaining lock nut	locking device	Appropriate hydraulic nut	
d ₁	d	d ₃	B ₁	B, B ₄	B ₅	G	G ₂	G ₃	A	Adapter sleeve with nut and locking device				
mm							kg		-					
200	220	260	96	30	41	Tr 220x4	M 6	9	4,2	7,95	OH 3944 H	HM 3044	MS 3044	HMV 44E
	220	260	126	30	41	Tr 220x4	M 6	9	4,2	9,9	OH 3044 H	HM 3044	MS 3044	HMV 44E
	220	260	161	30	41	Tr 220x4	M 6	9	4,2	14,5	OH 3144 HTL	HM 3044	MS 3044	HMV 44E
	220	280	161	35	-	Tr 220x4	M 6	9	4,2	15	OH 3144 H	HM 44 T	MB 44	HMV 44E
	220	280	186	35	-	Tr 220x4	M 6	9	4,2	17	OH 2344 H	HM 44 T	MB 44	HMV 44E
220	240	290	101	34	46	Tr 240x4	M 6	9	4,2	11	OH 3948 H	HM 3048	MS 3052-48	HMV 48E
	240	290	133	34	46	Tr 240x4	M 6	9	4,2	12	OH 3048 H	HM 3048	MS 3052-48	HMV 48E
	240	290	133	34	46	Tr 240x4	M 6	9	4,2	11,5	OH 3048 HE	HME 3048	MS 3052-48	HMV 48E
	240	290	172	34	46	Tr 240x4	M 6	9	4,2	15	OH 3148 HTL	HM 3048	MS 3052-48	HMV 48E
	240	300	172	37	-	Tr 240x4	M 6	9	4,2	16,5	OH 3148 H	HM 48 T	MB 48	HMV 48E
240	300	199	37	-	Tr 240x4	M 6	9	4,2	19	OH 2348 H	HM 48 T	MB 48	HMV 48E	
240	260	310	116	34	46	Tr 260x4	M 6	9	4,2	11,5	OH 3952 H	HM 3052	MS 3052-48	HMV 52E
	260	310	145	34	46	Tr 260x4	M 6	9	4,2	13,5	OH 3052 H	HM 3052	MS 3052-48	HMV 52E
	260	310	145	34	46	Tr 260x4	M 6	9	4,2	13,5	OH 3052 HE	HME 3052	MS 3052-48	HMV 52E
	260	310	190	34	46	Tr 260x4	M 6	9	4,2	17,5	OH 3152 HTL	HM 3052	MS 3052-48	HMV 52E
	260	330	190	39	-	Tr 260x4	M 6	9	4,2	21	OH 3152 H	HM 52 T	MB 52	HMV 52E
260	330	211	39	-	Tr 260x4	M 6	9	4,2	23	OH 2352 H	HM 52 T	MB 52	HMV 52E	
260	280	330	121	38	50	Tr 280x4	M 6	9	4,2	15,5	OH 3956 H	HM 3056	MS 3056	HMV 56E
	280	330	152	38	50	Tr 280x4	M 6	9	4,2	16	OH 3056 H	HM 3056	MS 3056	HMV 56E
	280	330	195	38	50	Tr 280x4	M 6	9	4,2	19,5	OH 3156 HTL	HM 3056	MS 3056	HMV 56E
	280	350	195	41	-	Tr 280x4	M 6	9	4,2	23	OH 3156 H	HM 56 T	MB 56	HMV 56E
	280	350	224	41	-	Tr 280x4	M 6	9	4,2	27	OH 2356 H	HM 56 T	MB 56	HMV 56E
280	300	360	140	42	54	Tr 300x4	M 6	9	4,2	20	OH 3960 H	HM 3060	MS 3060	HMV 60E
	300	360	168	42	54	Tr 300x4	M 6	9	4,2	20,5	OH 3060 H	HM 3060	MS 3060	HMV 60E
	300	380	208	40	53	Tr 300x4	M 6	9	4,2	29	OH 3160 H	HM 3160	MS 3160	HMV 60E
	300	380	208	40	53	Tr 300x4	M 6	9	4,2	27,5	OH 3160 HE	HME 3160	MS 3160	HMV 60E
	300	380	240	40	53	Tr 300x4	M 6	9	4,2	32	OH 3260 H	HM 3160	MS 3160	HMV 60E
300	320	380	140	42	55	Tr 320x5	M 6	9	4	21,5	OH 3964 H	HM 3064	MS 3068-64	HMV 64E
	320	380	171	42	55	Tr 320x5	M 6	9	4	22	OH 3064 H	HM 3064	MS 3068-64	HMV 64E
	320	400	226	42	56	Tr 320x5	M 6	9	4	32	OH 3164 H	HM 3164	MS 3164	HMV 64E
	320	400	258	42	56	Tr 320x5	M 6	9	4	35	OH 3264 H	HM 3164	MS 3164	HMV 64E

For oil injection variants not listed, contact SKF.

Principal dimensions										Mass	Designations	Appertaining	locking device	Appropriate hydraulic nut
d ₁	d	d ₃	B ₁	B	B ₅	G	G ₂	G ₃	A	kg	Adapter sleeve with nut and locking device	lock nut		
mm										kg	-			
320	340	400	144	45	58	Tr 340x5	M6	9	4	24,5	OH 3968 H	HM 3068	MS 3068-64	HMV 68E
	340	400	187	45	58	Tr 340x5	M6	9	4	27	OH 3068 H	HM 3068	MS 3068-64	HMV 68E
	340	440	254	55	72	Tr 340x5	M6	9	4	50	OH 3168 H	HM 3168	MS 3172-68	HMV 68E
	340	440	254	55	72	Tr 340x5	M6	9	4	46	OH 3168 HE	HME 3168	MS 3172-68	HMV 68E
	340	440	288	55	72	Tr 340x5	M6	9	4	51,5	OH 3268 H	HM 3168	MS 3172-68	HMV 68E
340	360	420	144	45	58	Tr 360x5	M6	9	4	25	OH 3972 H	HM 3072	MS 3072	HMV 72E
	360	420	144	45	58	Tr 360x5	M6	9	4	24,5	OH 3972 HE	HME 3072	MS 3072	HMV 72E
	360	420	188	45	58	Tr 360x5	M6	9	4	29	OH 3072 H	HM 3072	MS 3072	HMV 72E
	360	460	259	58	75	Tr 360x5	M6	9	4	56	OH 3172 H	HM 3172	MS 3172-68	HMV 72E
	360	460	259	58	75	Tr 360x5	M6	9	4	52	OH 3172 HE	HME 3172	MS 3172-68	HMV 72E
	360	460	299	58	75	Tr 360x5	M6	9	4	60,5	OH 3272 H	HM 3172	MS 3172-68	HMV 72E
360	380	450	164	48	62	Tr 380x5	M6	9	4	31,5	OH 3976 H	HM 3076	MS 3080-76	HMV 76E
	380	450	164	48	62	Tr 380x5	M6	9	4	30,5	OH 3976 HE	HME 3076	MS 3080-76	HMV 76E
	380	450	193	48	62	Tr 380x5	M6	9	4	35,5	OH 3076 H	HM 3076	MS 3080-76	HMV 76E
	380	490	264	60	77	Tr 380x5	M6	9	4	61,5	OH 3176 H	HM 3176	MS 3176	HMV 76E
	380	490	264	60	77	Tr 380x5	M6	9	4	58	OH 3176 HE	HME 3176	MS 3176	HMV 76E
	380	490	310	60	77	Tr 380x5	M6	9	4	69,5	OH 3276 H	HM 3176	MS 3176	HMV 76E
380	400	470	168	52	66	Tr 400x5	M6	9	4	35	OH 3980 H	HM 3080	MS 3080-76	HMV 80E
	400	470	168	52	66	Tr 400x5	M6	9	4	34	OH 3980 HE	HME 3080	MS 3080-76	HMV 80E
	400	470	210	52	66	Tr 400x5	M6	9	4	40	OH 3080 H	HM 3080	MS 3080-76	HMV 80E
	400	520	272	62	82	Tr 400x5	M6	9	4	73	OH 3180 H	HM 3180	MS 3184-80	HMV 80E
	400	520	272	62	82	Tr 400x5	M6	9	4	57	OH 3180 HE	HME 3180	MS 3184-80	HMV 80E
	400	520	328	62	82	Tr 400x5	M6	9	4	87	OH 3280 H	HM 3180	MS 3184-80	HMV 80E
400	420	490	168	52	66	Tr 420x5	M6	9	4	36	OH 3984 H	HM 3084	MS 3084	HMV 84E
	420	490	168	52	66	Tr 420x5	M6	9	4	34,5	OH 3984 HE	HME 3084	MS 3084	HMV 84E
	420	490	212	52	66	Tr 420x5	M6	9	4	47	OH 3084 H	HM 3084	MS 3084	HMV 84E
	420	540	304	70	90	Tr 420x5	M6	9	4	80	OH 3184 H	HM 3184	MS 3184-80	HMV 84E
	420	540	352	70	90	Tr 420x5	M6	9	4	96	OH 3284 H	HM 3184	MS 3184-80	HMV 84E
410	440	520	189	60	77	Tr 440x5	M8	12	6,5	58	OH 3988 H	HM 3088	MS 3092-88	HMV 88E
	440	520	189	60	77	Tr 440x5	M8	12	6,5	56	OH 3988 HE	HME 3088	MS 3092-88	HMV 88E
	440	520	228	60	77	Tr 440x5	M8	12	6,5	65	OH 3088 H	HM 3088	MS 3092-88	HMV 88E
	440	520	228	60	77	Tr 440x5	M8	12	6,5	63	OH 3088 HE	HME 3088	MS 3092-88	HMV 88E
	440	560	307	70	90	Tr 440x5	M8	12	6,5	95	OH 3188 H	HM 3188	MS 3192-88	HMV 88E
430	460	540	307	70	90	Tr 440x5	M8	12	6,5	91	OH 3188 HE	HME 3188	MS 3192-88	HMV 88E
	440	560	361	70	90	Tr 440x5	M8	12	6,5	117	OH 3288 H	HM 3188	MS 3192-88	HMV 88E
	460	540	189	60	77	Tr 460x5	M8	12	6,5	60	OH 3992 H	HM 3092	MS 3092-88	HMV 92E
	460	540	234	60	77	Tr 460x5	M8	12	6,5	71	OH 3092 H	HM 3092	MS 3092-88	HMV 92E
	460	580	326	75	95	Tr 460x5	M8	12	6,5	119	OH 3192 H	HM 3192	MS 3192-88	HMV 92E
450	460	580	382	75	95	Tr 460x5	M8	12	6,5	134	OH 3292 H	HM 3192	MS 3192-88	HMV 92E
	480	560	200	60	77	Tr 480x5	M8	12	6,5	66	OH 3996 H	HM 3096	MS 30/500-96	HMV 96E
	480	560	200	60	77	Tr 480x5	M8	12	6,5	64	OH 3996 HE	HME 3096	MS 30/500-96	HMV 96E
	480	560	237	60	77	Tr 480x5	M8	12	6,5	75	OH 3096 H	HM 3096	MS 30/500-96	HMV 96E
	480	620	335	75	95	Tr 480x5	M8	12	6,5	135	OH 3196 H	HM 3196	MS 3196	HMV 96E
	480	620	335	75	95	Tr 480x5	M8	12	6,5	128	OH 3196 HE	HME 3196	MS 3196	HMV 96E
470	480	620	397	75	95	Tr 480x5	M8	12	6,5	153	OH 3296 H	HM 3196	MS 3196	HMV 96E
	500	580	208	68	85	Tr 500x5	M8	12	6,5	74,5	OH 39/500 H	HM 30/500	MS 30/500-96	HMV 100E
	500	580	208	68	85	Tr 500x5	M8	12	6,5	72,5	OH 39/500 HE	HME 30/500	MS 30/500-96	HMV 100E
	500	580	247	68	85	Tr 500x5	M8	12	6,5	82	OH 30/500 H	HM 30/500	MS 30/500-96	HMV 100E
	500	630	356	80	100	Tr 500x5	M8	12	6,5	145	OH 31/500 H	HM 31/500	MS 31/500	HMV 100E
500	500	630	428	80	100	Tr 500x5	M8	12	6	170	OH 32/500 H	HM 31/500	MS 31/500	HMV 100E
	530	630	216	68	90	Tr 530x6	M8	12	6	88	OH 39/530 H	HM 30/530	MS 30/600-530	HMV 106E
	530	630	216	68	90	Tr 530x6	M8	12	6	82,5	OH 39/530 HE	HME 30/530	MS 30/600-530	HMV 106E
	530	630	265	68	90	Tr 530x6	M8	12	6	105	OH 30/530 H	HM 30/530	MS 30/600-530	HMV 106E
	530	670	364	80	105	Tr 530x6	M8	12	6	161	OH 31/530 H	HM 31/530	MS 31/530	HMV 106E
530	670	447	80	105	Tr 530x6	M8	12	6	192	OH 32/530 H	HM 31/530	MS 31/530	HMV 106E	

For oil injection variants not listed, contact SKF.

16.1 Adapter sleeves for metric shafts

d_1 530 – 1 000 mm

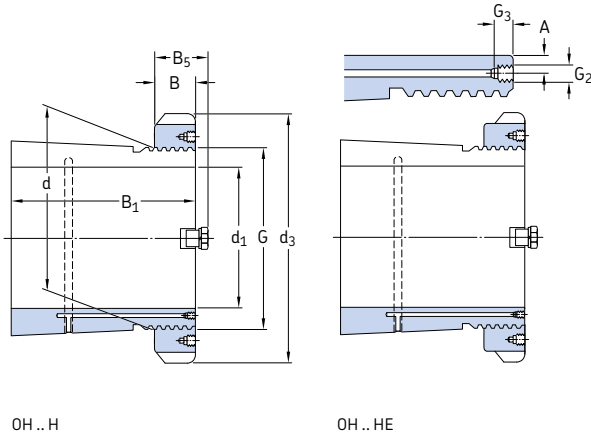

Principal dimensions							Mass		Designations					
d_1	d	d_3	B_1	B	B_5	G	G_2	G_3	A	Adapter sleeve with nut and locking device	Appertaining lock nut	locking device	Appropriate hydraulic nut	
mm							mm/in.		kg	-				
530	560	650	227	75	97	Tr 560x6	M 8	12	6	95	OH 39/560 H	HM 30/560	MS 30/560	HMV 112E
	560	650	227	75	97	Tr 560x6	M 8	12	6	91,5	OH 39/560 HE	HME 30/560	MS 30/560	HMV 112E
	560	650	282	75	97	Tr 560x6	M 8	12	6	112	OH 30/560 H	HM 30/560	MS 30/560	HMV 112E
	560	710	377	85	110	Tr 560x6	M 8	12	6	185	OH 31/560 H	HM 31/560	MS 31/600-560	HMV 112E
	560	710	377	85	110	Tr 560x6	M 8	12	6	179	OH 31/560 HE	HME 31/560	MS 31/600-560	HMV 112E
	560	710	462	85	110	Tr 560x6	M 8	12	6	219	OH 32/560 H	HM 31/560	MS 31/600-560	HMV 112E
560	600	700	239	75	97	Tr 600x6	G 1/8	13	8	127	OH 39/600 H	HM 30/600	MS 30/600-530	HMV 120E
	600	700	239	75	97	Tr 600x6	G 1/8	13	8	122	OH 39/600 HE	HME 30/600	MS 30/600-530	HMV 120E
	600	700	289	75	97	Tr 600x6	G 1/8	13	8	147	OH 30/600 H	HM 30/600	MS 30/600-530	HMV 120E
	600	750	399	85	110	Tr 600x6	G 1/8	13	8	234	OH 31/600 H	HM 31/600	MS 31/600-560	HMV 120E
	600	750	399	85	110	Tr 600x6	G 1/8	13	8	228	OH 31/600 HE	HME 31/600	MS 31/600-560	HMV 120E
	600	750	487	85	110	Tr 600x6	G 1/8	13	8	278	OH 32/600 H	HM 31/600	MS 31/600-560	HMV 120E
600	630	730	254	75	97	Tr 630x6	M 8	12	6	124	OH 39/630 H	HM 30/630	MS 30/630	HMV 126E
	630	730	254	75	97	Tr 630x6	M 8	12	6	119	OH 39/630 HE	HME 30/630	MS 30/630	HMV 126E
	630	730	301	75	97	Tr 630x6	M 8	12	6	138	OH 30/630 H	HM 30/630	MS 30/630	HMV 126E
	630	800	424	95	120	Tr 630x6	M 8	12	6	254	OH 31/630 H	HM 31/630	MS 31/630	HMV 126E
	630	800	424	95	120	Tr 630x6	M 8	12	6	244	OH 31/630 HE	HME 31/630	MS 31/630	HMV 126E
630	670	780	264	80	102	Tr 670x6	G 1/8	13	8	162	OH 39/670 H	HM 30/670	MS 30/670	HMV 134E
	670	780	324	80	102	Tr 670x6	G 1/8	13	8	190	OH 30/670 H	HM 30/670	MS 30/670	HMV 134E
	670	850	456	106	131	Tr 670x6	G 1/8	13	8	340	OH 31/670 H	HM 31/670	MS 31/670	HMV 134E
	670	850	456	106	131	Tr 670x6	G 1/8	13	8	329	OH 31/670 HE	HME 31/670	MS 31/670	HMV 134E
	670	850	558	106	131	Tr 670x6	G 1/8	13	8	401	OH 32/670 H	HM 31/670	MS 31/670	HMV 134E
	670	710	830	286	90	112	Tr 710x7	G 1/8	13	8	183	OH 39/710 H	HM 30/710	MS 30/710
710		830	286	90	112	Tr 710x7	G 1/8	13	8	173	OH 39/710 HE	HME 30/710	MS 30/710	HMV 142E
710		830	342	90	112	Tr 710x7	G 1/8	13	8	228	OH 30/710 H	HM 30/710	MS 30/710	HMV 142E
710		830	342	90	112	Tr 710x7	G 1/8	13	8	183	OH 30/710 HE	HME 30/710	MS 30/710	HMV 142E
710		900	467	106	135	Tr 710x7	G 1/8	13	8	392	OH 31/710 H	HM 31/710	MS 31/710	HMV 142E
710		900	467	106	135	Tr 710x7	G 1/8	13	8	379	OH 31/710 HE	HME 31/710	MS 31/710	HMV 142E
710		900	572	106	135	Tr 710x7	G 1/8	13	8	459	OH 32/710 H	HM 31/710	MS 31/710	HMV 142E

For oil injection variants not listed, contact SKF.

Principal dimensions										Mass	Designations	Appertaining	locking device	Appro-
d ₁	d	d ₃	B ₁	B	B ₅	G	G ₂	G ₃	A	kg	Adapter sleeve with nut and locking device	lock nut		appropriate hydraulic nut
mm										in.	kg	-		
710	750	870	291	90	112	Tr 750x7	G 1/8	13	8	211	OH 39/750 H	HM 30/750	MS 30/800-750	HMV 150E
	750	870	291	90	112	Tr 750x7	G 1/8	13	8	203	OH 39/750 HE	HME 30/750	MS 30/800-750	HMV 150E
	750	870	356	90	112	Tr 750x7	G 1/8	13	8	246	OH 30/750 H	HM 30/750	MS 30/800-750	HMV 150E
	750	870	356	90	112	Tr 750x7	G 1/8	13	8	238	OH 30/750 HE	HME 30/750	MS 30/800-750	HMV 150E
	750	950	493	112	141	Tr 750x7	G 1/8	13	8	451	OH 31/750 H	HM 31/750	MS 31/800-750	HMV 150E
	750	950	493	112	141	Tr 750x7	G 1/8	13	8	438	OH 31/750 HE	HME 31/750	MS 31/800-750	HMV 150E
	750	950	603	112	141	Tr 750x7	G 1/8	13	8	526	OH 32/750 H	HM 31/750	MS 31/800-750	HMV 150E
750	800	920	303	90	112	Tr 800x7	G 1/8	13	10	259	OH 39/800 H	HM 30/800	MS 30/800-750	HMV 160E
	800	920	303	90	112	Tr 800x7	G 1/8	13	10	250	OH 39/800 HE	HME 30/800	MS 30/800-750	HMV 160E
	800	920	366	90	112	Tr 800x7	G 1/8	13	10	302	OH 30/800 H	HM 30/800	MS 30/800-750	HMV 160E
	800	920	366	90	112	Tr 800x7	G 1/8	13	10	293	OH 30/800 HE	HME 30/800	MS 30/800-750	HMV 160E
	800	1000	505	112	141	Tr 800x7	G 1/8	13	10	535	OH 31/800 H	HM 31/800	MS 31/800-750	HMV 160E
	800	1000	505	112	141	Tr 800x7	G 1/8	13	10	520	OH 31/800 HE	HME 31/800	MS 31/800-750	HMV 160E
800	850	980	308	90	115	Tr 850x7	G 1/8	13	10	288	OH 39/850 H	HM 30/850	MS 30/900-850	HMV 170E
	850	980	308	90	115	Tr 850x7	G 1/8	13	10	277	OH 39/850 HE	HME 30/850	MS 30/900-850	HMV 170E
	850	980	380	90	115	Tr 850x7	G 1/8	13	10	341	OH 30/850 H	HM 30/850	MS 30/900-850	HMV 170E
	850	980	380	90	115	Tr 850x7	G 1/8	13	10	330	OH 30/850 HE	HME 30/850	MS 30/900-850	HMV 170E
	850	1060	536	118	147	Tr 850x7	G 1/8	13	10	616	OH 31/850 H	HM 31/850	MS 31/850	HMV 170E
	850	1060	536	118	147	Tr 850x7	G 1/8	13	10	594	OH 31/850 HE	HME 31/850	MS 31/850	HMV 170E
850	900	1030	326	100	125	Tr 900x7	G 1/8	13	10	330	OH 39/900 H	HM 30/900	MS 30/900-850	HMV 180E
	900	1030	326	100	125	Tr 900x7	G 1/8	13	10	316	OH 39/900 HE	HME 30/900	MS 30/900-850	HMV 180E
	900	1030	400	100	125	Tr 900x7	G 1/8	13	10	387	OH 30/900 H	HM 30/900	MS 30/900-850	HMV 180E
	900	1030	400	100	125	Tr 900x7	G 1/8	13	10	373	OH 30/900 HE	HME 30/900	MS 30/900-850	HMV 180E
	900	1120	557	125	154	Tr 900x7	G 1/8	13	10	677	OH 31/900 H	HM 31/900	MS 31/900	HMV 180E
900	950	1080	344	100	125	Tr 950x8	G 1/8	13	10	363	OH 39/950 H	HM 30/950	MS 30/950	HMV 190E
	950	1080	344	100	125	Tr 950x8	G 1/8	13	10	348	OH 39/950 HE	HME 30/950	MS 30/950	HMV 190E
	950	1080	420	100	125	Tr 950x8	G 1/8	13	10	424	OH 30/950 H	HM 30/950	MS 30/950	HMV 190E
	950	1080	420	100	125	Tr 950x8	G 1/8	13	10	409	OH 30/950 HE	HME 30/950	MS 30/950	HMV 190E
	950	1170	583	125	154	Tr 950x8	G 1/8	13	10	738	OH 31/950 H	HM 31/950	MS 31/950	HMV 190E
950	1000	1140	358	100	125	Tr 1000x8	G 1/8	13	10	407	OH 39/1000 H	HM 30/1000	MS 30/1000	HMV 200E
	1000	1140	430	100	125	Tr 1000x8	G 1/8	13	10	470	OH 30/1000 H	HM 30/1000	MS 30/1000	HMV 200E
	1000	1140	430	100	125	Tr 1000x8	G 1/8	13	10	454	OH 30/1000 HE	HME 30/1000	MS 30/1000	HMV 200E
	1000	1240	609	125	154	Tr 1000x8	G 1/8	13	10	842	OH 31/1000 H	HM 31/1000	MS 31/1000	HMV 200E
	1000	1240	609	125	154	Tr 1000x8	G 1/8	13	10	811	OH 31/1000 HE	HME 31/1000	MS 31/1000	HMV 200E
1000	1060	1200	372	100	125	Tr 1060x8	G 1/4	15	12	490	OH 39/1060 H	HM 30/1060	MS 30/1000	HMV 212E
	1060	1200	372	100	125	Tr 1060x8	G 1/4	15	12	473	OH 39/1060 HE	HME 30/1060	MS 30/1000	HMV 212E
	1060	1200	447	100	125	Tr 1060x8	G 1/4	15	12	571	OH 30/1060 H	HM 30/1060	MS 30/1000	HMV 212E
	1060	1300	622	125	154	Tr 1060x8	G 1/4	15	12	984	OH 31/1060 H	HM 31/1060	MS 31/1000	HMV 212E

For oil injection variants not listed and for bore diameter ≥ 1060 mm, contact SKF.

16.2 Adapter sleeves for inch shafts

d_1 $\frac{3}{4}$ – $3 \frac{3}{16}$ in.
19,05 – 80,963 mm

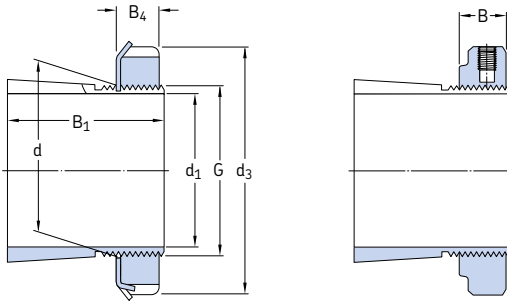

H, HA, HE, HE .. B

HA .. E, HE .. E, HA .. EL, HE .. EL, HE .. BE

Principal dimensions							Mass	Designations	Appertaining	locking	Appro-
d_1	d	d_3	B_1	B	B_4	G		Adapter sleeve with	lock nut	device	prate
								nut and locking			hydraulic
								device			nut
in./mm	mm						kg	-			
$\frac{3}{4}$ 19,05	25	38	26	7	8	M 25x1,5	0,07	HE 205	KM 5	MB 5	-
	25	38	29	7	8	M 25x1,5	0,08	HE 305	KM 5	MB 5	-
	25	38	29	10,5	-	M 25x1,5	0,088	HE 305 E	KMFE 5	-	-
	25	38	35	7	8	M 25x1,5	0,09	HE 2305	KM 5	MB 5	-
$\frac{15}{16}$ 23,813	30	45	27	7	8	M 30x1,5	0,1	HA 206	KM 6	MB 6	-
	30	45	31	7	8	M 30x1,5	0,12	HA 306	KM 6	MB 6	-
	30	45	31	10,5	-	M 30x1,5	0,13	HA 306 E	KMFE 6	-	-
	30	45	38	7	8	M 30x1,5	0,13	HA 2306	KM 6	MB 6	-
1 25,4	30	45	27	7	8	M 30x1,5	0,08	HE 206	KM 6	MB 6	-
	30	45	31	7	8	M 30x1,5	0,1	HE 306	KM 6	MB 6	-
	30	45	31	10,5	-	M 30x1,5	0,11	HE 306 E	KMFE 6	-	-
	30	45	38	7	8	M 30x1,5	0,11	HE 2306	KM 6	MB 6	-
$\frac{13}{16}$ 30,163	35	52	29	8	9	M 35x1,5	0,12	HA 207	KM 7	MB 7	-
	35	52	35	8	9	M 35x1,5	0,14	HA 307	KM 7	MB 7	-
	35	52	35	11,5	-	M 35x1,5	0,15	HA 307 EL	KMFE 7 L	-	-
	35	52	35	11,5	-	M 35x1,5	0,15	HA 307 E	KMFE 7	-	-
	35	52	43	8	9	M 35x1,5	0,16	HA 2307	KM 7	MB 7	-
$\frac{11}{4}$ 31,75	40	58	31	9	10	M 40x1,5	0,19	HE 208	KM 8	MB 8	-
	40	58	36	9	10	M 40x1,5	0,22	HE 308	KM 8	MB 8	-
	40	58	36	13	-	M 40x1,5	0,19	HE 308 E	KMFE 8	-	-
	40	58	46	9	10	M 40x1,5	0,28	HE 2308	KM 8	MB 8	-
	40	58	46	13	-	M 40x1,5	0,3	HE 2308 E	KMFE 8	-	-
$\frac{17}{16}$ 36,513	45	65	33	10	11	M 45x1,5	0,26	HA 209	KM 9	MB 9	-
	45	65	39	10	11	M 45x1,5	0,29	HA 309	KM 9	MB 9	-
	45	65	39	13	-	M 45x1,5	0,31	HA 309 E	KMFE 9	-	-
	45	65	50	10	11	M 45x1,5	0,35	HA 2309	KM 9	MB 9	-
$\frac{11}{2}$ 38,1	45	65	33	10	11	M 45x1,5	0,2	HE 209	KM 9	MB 9	-
	45	65	39	10	11	M 45x1,5	0,24	HE 309	KM 9	MB 9	-
	45	65	39	13	-	M 45x1,5	0,31	HE 309 E	KMFE 9	-	-
	45	65	50	10	11	M 45x1,5	0,31	HE 2309	KM 9	MB 9	-
$\frac{113}{16}$ 42,863	50	70	35	11	12	M 50x1,5	0,28	HA 210	KM 10	MB 10	HMV 10E
	50	70	42	11	12	M 50x1,5	0,32	HA 310	KM 10	MB 10	HMV 10E
	50	70	42	14	-	M 50x1,5	0,32	HA 310 E	KMFE 10	-	HMV 10E
	50	70	55	11	12	M 50x1,5	0,4	HA 2310	KM 10	MB 10	HMV 10E

Principal dimensions							Mass	Designations	Appertaining	locking	Appro-
d ₁	d	d ₃	B ₁	B	B ₄	G		Adapter sleeve with nut and locking device	lock nut	device	priate hydraulic nut
in./mm	mm						kg	-			
1 3/4 44,45	50	70	35	11	12	M 50x1,5	0,26	HE 210	KM 10	MB 10	HMV 10E
	50	70	42	11	12	M 50x1,5	0,29	HE 310	KM 10	MB 10	HMV 10E
	50	70	42	14	-	M 50x1,5	0,29	HE 310 E	KMFE 10	-	HMV 10E
	50	70	55	11	12	M 50x1,5	0,36	HE 2310	KM 10	MB 10	HMV 10E
1 15/16 49,213	55	75	37	11	12,5	M 55x2	0,3	HA 211	KM 11	MB 11	HMV 11E
	55	75	45	11	12,5	M 55x2	0,34	HA 311	KM 11	MB 11	HMV 11E
	55	75	45	14	-	M 55x2	0,35	HA 311 E	KMFE 11	-	HMV 11E
	55	75	59	11	12,5	M 55x2	0,42	HA 2311	KM 11	MB 11	HMV 11E
2 50,8	55	75	37	11	12,5	W 55x1/19	0,26	HE 211 B	HM 11	MB 11	-
	55	75	45	11	12,5	W 55x1/19	0,29	HE 311 B	HM 11	MB 11	-
	55	75	45	14	-	W 55x1/19	0,29	HE 311 BE	KMFE 11 B	-	-
	55	75	59	11	12,5	W 55x1/19	0,36	HE 2311 B	HM 11	MB 11	-
2 3/16 55,563	65	85	40	12	13,5	M 65x2	0,49	HA 213	KM 13	MB 13	HMV 13E
	65	85	50	12	13,5	M 65x2	0,58	HA 313	KM 13	MB 13	HMV 13E
	65	85	50	15	-	M 65x2	0,59	HA 313 E	KMFE 13	-	HMV 13E
	65	85	65	12	13,5	M 65x2	0,75	HA 2313	KM 13	MB 13	HMV 13E
	65	85	65	15	-	M 65x2	0,76	HA 2313 E	KMFE 13	-	HMV 13E
2 1/4 57,15	65	85	40	12	13,5	M 65x2	0,44	HE 213	KM 13	MB 13	HMV 13E
	65	85	50	12	13,5	M 65x2	0,52	HE 313	KM 13	MB 13	HMV 13E
	65	85	50	15	-	M 65x2	0,53	HE 313 E	KMFE 13	-	HMV 13E
	65	85	65	12	13,5	M 65x2	0,65	HE 2313	KM 13	MB 13	HMV 13E
	65	85	65	15	-	M 65x2	0,66	HE 2313 E	KMFE 13	-	HMV 13E
2 7/16 61,913	75	98	43	13	15	M 75x2	0,75	HA 215	KM 15	MB 15	HMV 15E
	75	98	55	13	15	M 75x2	0,91	HA 315	KM 15	MB 15	HMV 15E
	75	98	55	16	-	M 75x2	0,93	HA 315 E	KMFE 15	-	HMV 15E
	75	98	73	13	15	M 75x2	1,15	HA 2315	KM 15	MB 15	HMV 15E
2 1/2 63,5	75	98	43	13	15	M 75x2	0,7	HE 215	KM 15	MB 15	HMV 15E
	75	98	55	13	15	M 75x2	0,85	HE 315	KM 15	MB 15	HMV 15E
	75	98	55	16	-	M 75x2	0,87	HE 315 E	KMFE 15	-	HMV 15E
	75	98	73	13	15	M 75x2	1,1	HE 2315	KM 15	MB 15	HMV 15E
2 11/16 68,263	80	105	46	15	17	M 80x2	0,87	HA 216	KM 16	MB 16	HMV 16E
	80	105	59	15	17	M 80x2	1,05	HA 316	KM 16	MB 16	HMV 16E
	80	105	59	18	-	M 80x2	1,05	HA 316 E	KMFE 16	-	HMV 16E
	80	105	78	15	17	M 80x2	1,3	HA 2316	KM 16	MB 16	HMV 16E
2 3/4 69,85	80	105	46	15	17	M 80x2	0,81	HE 216	KM 16	MB 16	HMV 16E
	80	105	59	15	17	M 80x2	0,97	HE 316	KM 16	MB 16	HMV 16E
	80	105	59	18	-	M 80x2	0,98	HE 316 E	KMFE 16	-	HMV 16E
	80	105	78	15	17	M 80x2	1,2	HE 2316	KM 16	MB 16	HMV 16E
2 15/16 74,613	85	110	50	16	18	M 85x2	0,94	HA 217	KM 17	MB 17	HMV 17E
	85	110	63	16	18	M 85x2	1,1	HA 317	KM 17	MB 17	HMV 17E
	85	110	63	19	-	M 85x2	1,2	HA 317 E	KMFE 17	-	HMV 17E
	85	110	82	16	18	M 85x2	1,4	HA 2317	KM 17	MB 17	HMV 17E
3 76,2	85	110	50	16	18	M 85x2	0,87	HE 217	KM 17	MB 17	HMV 17E
	85	110	63	16	18	M 85x2	1	HE 317	KM 17	MB 17	HMV 17E
	85	110	63	19	-	M 85x2	0,99	HE 317 E	KMFE 17	-	HMV 17E
	85	110	82	16	18	M 85x2	1,3	HE 2317	KM 17	MB 17	HMV 17E
3 3/16 80,963	90	120	52	16	18	M 90x2	1,05	HA 218	KM 18	MB 18	HMV 18E
	90	120	65	16	18	M 90x2	1,25	HA 318	KM 18	MB 18	HMV 18E
	90	120	65	19	-	M 90x2	1,25	HA 318 E	KMFE 18	-	HMV 18E
	90	120	73	19	-	M 90x2	1,4	HA 2318 E/L73¹⁾	KMFE 18	-	HMV 18E
	90	120	86	16	18	M 90x2	1,5	HA 2318	KM 18	MB 18	HMV 18E

¹⁾ Width reduced to 73 mm

16.2 Adapter sleeves for inch shafts

d_1 3 1/4 – 5 1/4 in.
82,55 – 133,35 mm

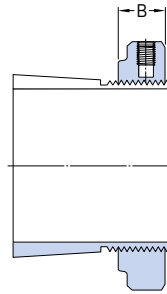
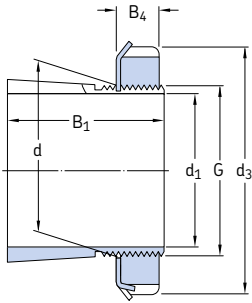

HE, HA, HA .. L

HA .. E, HE .. E, HA .. EH, HE .. EH, HE .. EL

Principal dimensions							Mass	Designations	Appertaining	locking	Appro-	
d_1	d	d_3	B_1	B	B_4	G		Adapter sleeve with	lock nut	device	prate	
								nut and locking			hydraulic	
								device			nut	
in./mm	mm						kg	-				
3 1/4 82,55	90	120	52	16	18	M 90x2	0,97	HE 218	KM 18	MB 18	HMV 18E	
	90	120	65	16	18	M 90x2	1,1	HE 318	KM 18	MB 18	HMV 18E	
	90	120	65	19	-	M 90x2	1,1	HE 318 E	KMFE 18	-	HMV 18E	
	90	120	73	19	-	M 90x2	1,3	HE 2318 E/L73 ¹⁾	KMFE 18	-	HMV 18E	
	90	120	86	16	18	M 90x2	1,4	HE 2318	KM 18	MB 18	HMV 18E	
	95	125	55	17	19	M 95x2	1,35	HE 219	KM 19	MB 19	HMV 19E	
	95	125	68	17	19	M 95x2	1,6	HE 319	KM 19	MB 19	HMV 19E	
	95	125	68	20	-	M 95x2	1,6	HE 319 E	KMFE 19	-	HMV 19E	
	95	125	90	17	19	M 95x2	2	HE 2319	KM 19	MB 19	HMV 19E	
	95	125	90	20	-	M 95x2	2,05	HE 2319 EL	KMFE 19 L	-	HMV 20E	
3 7/16 87,313	100	130	58	18	20	M 100x2	1,55	HA 220	KM 20	MB 20	HMV 20E	
	100	130	71	18	20	M 100x2	1,8	HA 320	KM 20	MB 20	HMV 20E	
	100	130	71	21	-	M 100x2	1,75	HA 320 E	KMFE 20	-	HMV 20E	
	100	130	97	18	20	M 100x2	2,35	HA 2320	KM 20	MB 20	HMV 20E	
	100	130	97	21	-	M 100x2	2,35	HA 2320 E	KMFE 20	-	HMV 20E	
3 1/2 88,9	100	130	58	18	20	M 100x2	1,45	HE 220	KM 20	MB 20	HMV 20E	
	100	130	71	18	20	M 100x2	1,75	HE 320	KM 20	MB 20	HMV 20E	
	100	130	71	21	-	M 100x2	1,7	HE 320 E	KMFE 20	-	HMV 20E	
	100	130	76	18	20	M 100x2	1,8	HE 3120	KM 20	MB 20	HMV 20E	
	100	130	76	21	-	M 100x2	1,8	HE 3120 E	KMFE 20	-	HMV 20E	
	100	130	97	18	20	M 100x2	2,2	HE 2320	KM 20	MB 20	HMV 20E	
	100	130	97	21	-	M 100x2	2,2	HE 2320 E	KMFE 20	-	HMV 20E	
	4 101,6	110	145	63	19	21	M 110x2	1,65	HE 222	KM 22	MB 22	HMV 22E
		110	145	77	19	21	M 110x2	1,9	HE 322	KM 22	MB 22	HMV 22E
		110	145	77	21,5	-	M 110x2	1,85	HE 322 E	KMFE 22	-	HMV 22E
110		145	81	19	21	M 110x2	2,25	HE 3122	KM 22	MB 22	HMV 22E	
110		145	81	21,5	-	M 110x2	2,3	HE 3122 E	KMFE 22	-	HMV 22E	
110	145	105	19	21	M 110x2	2,4	HE 2322	KM 22	MB 22	HMV 22E		
110	145	105	21,5	-	M 110x2	2,4	HE 2322 E	KMFE 22	-	HMV 22E		

¹⁾ Width reduced to 73 mm

Principal dimensions							Mass	Designations Adapter sleeve with nut and locking device	Appertaining lock nut	locking device	Appro- priate hydraulic nut	
d ₁	d	d ₃	B ₁	B	B ₄	G						
in./mm	mm						kg	-				
4 3/16 106,363	120	145	72	20	22	M 120x2	2,25	HA 3024	KML 24	MBL 24	HMV 24E	
	120	145	88	20	22	M 120x2	2,6	HA 3124 L	KML 24	MBL 24	HMV 24E	
	120	145	112	20	22	M 120x2	3,3	HA 2324 L	KML 24	MBL 24	HMV 24E	
	120	155	72	26	-	M 120x2	2,3	HA 3024 E	KMFE 24	-	HMV 24E	
	120	155	88	20	22	M 120x2	2,9	HA 3124	KM 24	MB 24	HMV 24E	
	120	155	112	20	22	M 120x2	3,6	HA 2324	KM 24	MB 24	HMV 24E	
	120	155	112	26	-	M 120x2	3,7	HA 2324 E	KMFE 24	-	HMV 24E	
	120	155	112	26	-	M 120x2	3,65	HA 2324 EH	KMFE 24 H	-	HMV 24E	
	4 1/4 107,95	120	145	72	20	22	M 120x2	2	HE 3024	KML 24	MBL 24	HMV 24E
		120	145	112	20	22	M 120x2	3,05	HE 2324 L	KML 24	MBL 24	HMV 24E
120		155	72	26	-	M 120x2	2,7	HE 3024 E	KMFE 24	-	HMV 24E	
120		155	88	20	22	M 120x2	2,8	HE 3124	KM 24	MB 24	HMV 24E	
120		155	112	20	22	M 120x2	3,35	HE 2324	KM 24	MB 24	HMV 24E	
120		155	112	26	-	M 120x2	3,45	HE 2324 E	KMFE 24	-	HMV 24E	
120		155	112	26	-	M 120x2	3,4	HE 2324 EH	KMFE 24 H	-	HMV 24E	
4 7/16 112,713		130	155	80	21	23	M 130x2	3,05	HA 3026	KML 26	MBL 26	HMV 26E
		130	155	92	21	23	M 130x2	3,55	HA 3126 L	KML 26	MBL 26	HMV 26E
		130	155	121	21	23	M 130x2	4,45	HA 2326 L	KML 26	MBL 26	HMV 26E
	130	165	80	28	-	M 130x2	3,15	HA 3026 E	KMFE 26	-	HMV 26E	
	130	165	92	21	23	M 130x2	3,75	HA 3126	KM 26	MB 26	HMV 26E	
	130	165	92	28	-	M 130x2	3,75	HA 3126 E	KMFE 26	-	HMV 26E	
	130	165	121	21	23	M 130x2	4,75	HA 2326	KM 26	MB 26	HMV 26E	
	4 1/2 114,3	130	155	80	21	23	M 130x2	2,9	HE 3026	KML 26	MBL 26	HMV 26E
		130	155	92	21	23	M 130x2	3,4	HE 3126 L	KML 26	MBL 26	HMV 26E
		130	155	121	21	23	M 130x2	4,25	HE 2326 L	KML 26	MBL 26	HMV 26E
130		165	80	28	-	M 130x2	3	HE 3026 E	KMFE 26	-	HMV 26E	
130		165	92	21	23	M 130x2	3,6	HE 3126	KM 26	MB 26	HMV 26E	
130		165	121	21	23	M 130x2	4,55	HE 2326	KM 26	MB 26	HMV 26E	
4 15/16 125,413		140	165	82	22	24	M 140x2	3	HA 3028	KML 28	MBL 28	HMV 28E
	140	165	97	22	24	M 140x2	4,6	HA 3128 L	KML 28	MBL 28	HMV 28E	
	140	180	82	28	-	M 140x2	3	HA 3028 E	KMFE 28	-	HMV 28E	
	140	180	97	22	24	M 140x2	4,1	HA 3128	KM 28	MB 28	HMV 28E	
	140	180	131	22	24	M 140x2	5,3	HA 2328	KM 28	MB 28	HMV 28E	
	5 127	140	165	82	22	24	M 140x2	2,8	HE 3028	KML 28	MBL 28	HMV 28E
140		165	97	22	24	M 140x2	3,3	HE 3128 L	KML 28	MBL 28	HMV 28E	
140		180	82	28	-	M 140x2	2,8	HE 3028 E	KMFE 28	-	HMV 28E	
140		180	97	22	24	M 140x2	3,8	HE 3128	KM 28	MB 28	HMV 28E	
140		180	131	22	24	M 140x2	5	HE 2328	KM 28	MB 28	HMV 28E	
5 3/16 131,763		150	180	87	24	26	M 150x2	4,2	HA 3030	KML 30	MBL 30	HMV 30E
	150	180	111	24	26	M 150x2	5,3	HA 3130 L	KML 30	MBL 30	HMV 30E	
	150	180	139	24	26	M 150x2	6,45	HA 2330 L	KML 30	MBL 30	HMV 30E	
	150	195	87	30	-	M 150x2	4,2	HA 3030 E	KMFE 30	-	HMV 30E	
	150	195	111	24	26	M 150x2	5,8	HA 3130	KM 30	MB 30	HMV 30E	
	150	195	111	30	-	M 150x2	5,8	HA 3130 E	KMFE 30	-	HMV 30E	
	150	195	139	24	26	M 150x2	7,1	HA 2330	KM 30	MB 30	HMV 30E	
	5 1/4 133,35	150	180	87	24	26	M 150x2	4	HE 3030	KML 30	MBL 30	HMV 30E
150		180	111	24	26	M 150x2	5	HE 3130 L	KML 30	MBL 30	HMV 30E	
150		180	139	24	26	M 150x2	6,15	HE 2330 L	KML 30	MBL 30	HMV 30E	
150		195	111	24	26	M 150x2	5,5	HE 3130	KM 30	MB 30	HMV 30E	
150		195	111	30	-	M 150x2	4	HE 3030 E	KMFE 30	-	HMV 30E	
150		195	111	30	-	M 150x2	5,5	HE 3130 E	KMFE 30	-	HMV 30E	
150		195	139	24	26	M 150x2	6,8	HE 2330	KM 30	MB 30	HMV 30E	

16.2 Adapter sleeves for inch shafts

d_1 5 7/16 – 7 3/16 in.

139,113 – 182,563 mm

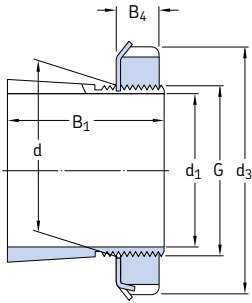

HA, HE, HA .. L, HE .. L

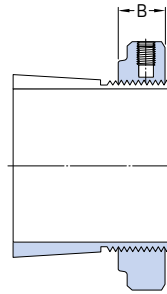

HA .. E, HE .. E

Principal dimensions							Mass	Designations	Appertaining	locking	Appro-	
d_1	d	d_3	B_1	B	B_4	G		Adapter sleeve with	lock nut	device	prate	
in./mm	mm						kg	nut and locking			hydraulic	
								device			nut	
57/16 138,113	160	190	93	25	27,5	M 160x3	5,2	HA 3032	KML 32	MBL 32	HMV 32E	
	160	190	147	25	27,5	M 160x3	9,4	HA 2332 L	KML 32	MBL 32	HMV 32E	
	160	210	93	32	–	M 160x3	5,2	HA 3032 E	KMFE 32	–	HMV 32E	
	160	210	119	25	27,5	M 160x3	7,55	HA 3132	KM 32	MB 32	HMV 32E	
	160	210	119	32	–	M 160x3	7,55	HA 3132 E	KMFE 32	–	HMV 32E	
	160	210	147	25	27,5	M 160x3	9,4	HA 2332	KM 32	MB 32	HMV 32E	
5 1/2 139,7	160	190	93	25	27,5	M 160x3	5,1	HE 3032	KML 32	MBL 32	HMV 32E	
	160	190	119	25	27,5	M 160x3	7,55	HA 3132 L	KML 32	MBL 32	HMV 32E	
	160	190	119	25	27,5	M 160x3	7,3	HE 3132 L	KML 32	MBL 32	HMV 32E	
	160	190	147	25	27,5	M 160x3	8,8	HE 2332 L	KML 32	MBL 32	HMV 32E	
	160	210	93	32	–	M 160x3	5,1	HE 3032 E	KMFE 32	–	HMV 32E	
	160	210	119	25	27,5	M 160x3	7,3	HE 3132	KM 32	MB 32	HMV 32E	
	160	210	119	32	–	M 160x3	7,3	HE 3132 E	KMFE 32	–	HMV 32E	
	160	210	147	25	27,5	M 160x3	8,8	HE 2332	KM 32	MB 32	HMV 32E	
	5 15/16 150,813	170	200	101	26	28,5	M 170x3	5,7	HA 3034	KML 34	MBL 34	HMV 34E
		170	200	122	26	28,5	M 170x3	6,8	HA 3134 L	KML 34	MBL 34	HMV 34E
170		220	122	26	28,5	M 170x3	7,8	HA 3134	KM 34	MB 34	HMV 34E	
170		220	122	33	–	M 170x3	7,9	HA 3134 E	KMFE 34	–	HMV 34E	
170		220	154	26	28,5	M 170x3	9,6	HA 2334	KM 34	MB 34	HMV 34E	
6 152,4	170	200	101	26	28,5	M 170x3	5,4	HE 3034	KML 34	MBL 34	HMV 34E	
	170	200	122	26	28,5	M 170x3	7,55	HE 3134 L	KML 34	MBL 34	HMV 34E	
	170	220	101	33	–	M 170x3	5,75	HA 3034 E	KMFE 34	–	HMV 34E	
	170	220	101	33	–	M 170x3	5,5	HE 3034 E	KMFE 34	–	HMV 34E	
	170	220	122	26	28,5	M 170x3	7,55	HE 3134	KM 34	MB 34	HMV 34E	
	170	220	122	33	–	M 170x3	7,65	HE 3134 E	KMFE 34	–	HMV 34E	
	170	220	154	26	28,5	M 170x3	9,2	HE 2334	KM 34	MB 34	HMV 34E	
	6 7/16 163,513	180	210	109	27	29,5	M 180x3	6	HA 3036	KML 36	MBL 36	HMV 36E
		180	230	122	34	–	M 180x3	7,2	HA 3036 E	KMFE 36	–	HMV 36E
180		230	131	27	29,5	M 180x3	8,15	HA 3136	KM 36	MB 36	HMV 36E	
180		230	161	27	29,5	M 180x3	9,9	HA 2336	KM 36	MB 36	HMV 36E	

Principal dimensions							Mass	Designations Adapter sleeve with nut and locking device	Appertaining lock nut	locking device	Appro- priate hydraulic nut
d ₁	d	d ₃	B ₁	B	B ₄	G					
in./mm	mm						kg	-			
6¹/₂ 165,1	180	210	109	27	29,5	M180x3	5,55	HE 3036	KML 36	MBL 36	HMV 36E
	180	210	131	27	29,5	M180x3	6,85	HA 3136 L	KML 36	MBL 36	HMV 36E
	180	230	122	34	-	M180x3	6,75	HE 3036 E	KMFE 36	-	HMV 36E
	180	230	131	27	29,5	M180x3	7,8	HE 3136	KM 36	MB 36	HMV 36E
	180	230	161	27	29,5	M180x3	9,35	HE 2336	KM 36	MB 36	HMV 36E
6³/₄ 171,45	190	220	112	28	30,5	M190x3	7,2	HE 3038	KML 38	MBL 38	HMV 38E
	190	240	141	28	30,5	M190x3	10	HE 3138	KM 38	MB 38	HMV 38E
	190	240	169	28	30,5	M190x3	11,5	HE 2338	KM 38	MB 38	HMV 38E
6¹⁵/₁₆ 176,213	190	220	112	28	30,5	M190x3	5,8	HA 3038	KML 38	MBL 38	HMV 38E
	190	240	141	28	30,5	M190x3	8,5	HA 3138	KM 38	MB 38	HMV 38E
	190	240	169	28	30,5	M190x3	10	HA 2338	KM 38	MB 38	HMV 38E
7 177,8	200	240	120	29	31,5	M200x3	9,35	HE 3040	KML 40	MBL 40	HMV 40E
	200	240	176	29	31,5	M200x3	13,5	HE 2340 L	KML 40	MBL 40	HMV 40E
	200	250	150	29	31,5	M200x3	12,5	HE 3140	KM 40	MB 40	HMV 40E
	200	250	176	29	31,5	M200x3	14	HE 2340	KM 40	MB 40	HMV 40E
7³/₁₆ 182,563	200	240	120	29	31,5	M200x3	8,25	HA 3040	KML 40	MBL 40	HMV 40E
	200	240	176	29	31,5	M200x3	12	HA 2340 L	KML 40	MBL 40	HMV 40E
	200	250	150	29	31,5	M200x3	11	HA 3140	KM 40	MB 40	HMV 40E
	200	250	176	29	31,5	M200x3	12,5	HA 2340	KM 40	MB 40	HMV 40E

16.3 Adapter sleeves with inch dimensions

d_1 $\frac{3}{4}$ – $4 \frac{3}{16}$ in.
19,05 – 106,363 mm

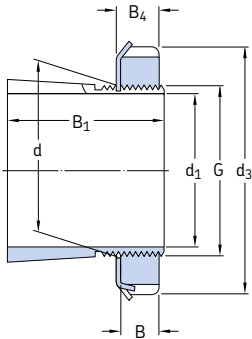

Principal dimensions			Thread		Mass	Designations						
d_1	d	d_3	B_1	B		B_4	G	Threads per inch	Adapter sleeve with nut and locking device	Appertaining lock nut	Appropriate locking device	Appropriate hydraulic nut
in./mm	mm	in.					in.	–	kg	–		
$\frac{3}{4}$ 19,05	25	$1 \frac{9}{16}$	1,269	0,416	0,456	0,969	32	0,1	SNW 5 x 3/4	N05	W05	–
$\frac{15}{16}$ 23,813	30	$1 \frac{3}{4}$	1,353	0,416	0,456	1,173	18	0,1	SNW 6 x 15/16	N06	W06	–
1 25,4	30	$1 \frac{3}{4}$	1,353	0,416	0,456	1,173	18	0,1	SNW 6 x 1	N06	W06	–
$1 \frac{1}{8}$ 28,575	35	$2 \frac{1}{16}$	1,459	0,448	0,488	1,376	18	0,16	SNW 7 x 1 1/8	N07	W07	–
$1 \frac{3}{16}$ 30,163	35	$2 \frac{1}{16}$	1,459	0,448	0,488	1,376	18	0,16	SNW 7 x 1 3/16	N07	W07	–
$1 \frac{1}{4}$ 31,75	35 40	$2 \frac{1}{16}$ $2 \frac{1}{4}$	1,459 1,504	0,448 0,448	0,488 0,496	1,376 1,563	18 18	0,16 0,19	SNW 7 x 1 1/4 SNW 8 x 1 1/4	N07 N08	W07 W08	– –
$1 \frac{3}{8}$ 34,925	40 45	$2 \frac{1}{4}$ $2 \frac{17}{32}$	1,504 1,584	0,448 0,448	0,496 0,496	1,563 1,767	18 18	0,19 0,28	SNW 8 x 1 3/8 SNW 9 x 1 3/8	N08 N09	W08 W09	– –
$1 \frac{5}{16}$ 33,338	40 45	$2 \frac{1}{4}$ $2 \frac{17}{32}$	1,504 1,584	0,448 0,448	0,496 0,496	1,563 1,767	18 18	0,19 0,28	SNW 8 x 1 5/16 SNW 9 x 1 5/16	N08 N09	W08 W09	– –
$1 \frac{7}{16}$ 36,513	45 45	$2 \frac{17}{32}$ $2 \frac{17}{32}$	1,584 2,133	0,448 0,448	0,496 0,496	1,767 1,767	18 18	0,28 0,32	SNW 9 x 1 7/16 SNW 109 x 1 7/16	N09 N09	W09 W09	– –
$1 \frac{1}{2}$ 38,1	45	$2 \frac{17}{32}$	2,133	0,448	0,496	1,767	18	0,32	SNW 109 x 1 1/2	N09	W09	–
$1 \frac{5}{8}$ 41,275	50	$2 \frac{11}{16}$	1,765	0,51	0,558	1,967	18	0,33	SNW 10 x 1 5/8	N10	W10	HMVC10E
$1 \frac{11}{16}$ 42,863	50 50	$2 \frac{11}{16}$ $2 \frac{11}{16}$	1,765 2,394	0,51 0,51	0,558 0,558	1,967 1,967	18 18	0,33 0,39	SNW 10 x 1 11/16 SNW 110 x 1 11/16	N10 N10	W10 W10	HMVC10E HMVC10E
$1 \frac{3}{4}$ 44,45	50 55	$2 \frac{11}{16}$ $2 \frac{31}{32}$	1,765 1,845	0,51 0,51	0,558 0,563	1,967 2,157	18 18	0,33 0,36	SNW 10 x 1 3/4 SNW 11 x 1 3/4	N10 N11	W10 W11	HMVC10E HMVC11E
$1 \frac{13}{16}$ 46,038	55	$2 \frac{31}{32}$	1,845	0,51	0,563	2,157	18	0,36	SNW 11 x 1 13/16	N11	W11	HMVC11E

Principal dimensions						Thread	Mass	Designations				
d ₁	d	d ₃	B ₁	B	B ₄	G	Threads per inch	Adapter sleeve with nut and locking device	Appertaining lock nut	locking device	Appropriate hydraulic nut	
in./mm	mm	in.				in.	–	kg	–			
1 7/8 47,625	55	2 ³¹ /32	1,845	0,51	0,563	2,157	18	0,36	SNW 11 x 1 7/8	N 11	W 11	HMVC 11E
1 15/16 49,213	55	2 ³¹ /32	1,845	0,51	0,563	2,157	18	0,36	SNW 11 x 1 15/16	N 11	W 11	HMVC 11E
	55	2 ³¹ /32	2,516	0,51	0,563	2,157	18	0,43	SNW 111 x 1 15/16	N 11	W 11	HMVC 11E
2 50,8	55	2 ³¹ /32	1,845	0,51	0,563	2,157	18	0,36	SNW 11 x 2	N 11	W 11	HMVC 11E
	55	2 ³¹ /32	2,516	0,51	0,563	2,157	18	0,43	SNW 111 x 2	N 11	W 11	HMVC 11E
	65	3 ³ /8	2,1	0,573	0,626	2,548	18	0,64	SNW 13 x 2	N 13	W 13	HMVC 13E
2 1/16 52,388	60	3 ⁵ /32	2,659	0,541	0,594	2,36	18	0,73	SNW 112 x 2 1/16	N 12	W 12	HMVC 12E
2 3/16 55,563	65	3 ³ /8	2,1	0,573	0,626	2,548	18	0,64	SNW 13 x 2 3/16	N 13	W 13	HMVC 13E
	65	3 ³ /8	2,771	0,573	0,626	2,548	18	0,79	SNW 113 x 2 3/16	N 13	W 13	HMVC 13E
2 1/4 57,15	65	3 ³ /8	2,1	0,573	0,626	2,548	18	0,64	SNW 13 x 2 1/4	N 13	W 13	HMVC 13E
	65	3 ³ /8	2,771	0,573	0,626	2,548	18	0,79	SNW 113 x 2 1/4	N 13	W 13	HMVC 13E
2 5/16 58,738	65	3 ³ /8	2,1	0,573	0,626	2,548	18	0,64	SNW 13 x 2 5/16	N 13	W 13	HMVC 13E
2 3/8 60,325	75	3 ³ /8	2,296	0,604	0,666	2,933	12	1	SNW 15 x 2 3/8	AN 15	W 15	HMVC 15E
2 7/16 61,913	75	3 ⁷ /8	2,296	0,604	0,666	2,933	12	1	SNW 15 x 2 7/16	AN 15	W 15	HMVC 15E
	75	3 ⁷ /8	3,084	0,604	0,666	2,933	12	1,35	SNW 115 x 2 7/16	AN 15	W 15	HMVC 15E
2 11/16 68,263	80	4 ⁵ /32	2,376	0,604	0,666	3,137	12	1,1	SNW 16 X 2 11/16	AN 16	W 16	HMVC 16E
	80	4 ⁵ /32	3,204	0,604	0,666	3,137	12	1,45	SNW 116 X 2 11/16	AN 16	W 16	HMVC 16E
2 3/4 69,85	80	4 ⁵ /32	2,376	0,604	0,666	3,137	12	1,1	SNW 16 X 2 3/4	AN 16	W 16	HMVC 16E
2 5/8 74,613	85	4 ¹³ /32	2,486	0,635	0,697	3,34	12	1,3	SNW 17 x 2 5/8	AN 17	W 17	HMVC 17E
	85	4 ¹³ /32	3,312	0,635	0,697	3,34	12	1,55	SNW 117 x 2 5/8	AN 17	W 17	HMVC 17E
3 76,2	85	4 ¹³ /32	2,486	0,635	0,697	3,34	12	1,3	SNW 17 x 3	AN 17	W 17	HMVC 17E
	85	4 ¹³ /32	3,312	0,635	0,697	3,34	12	1,55	SNW 117 x 3	AN 17	W 17	HMVC 17E
3 1/16 80,963	90	4 ²¹ /32	2,646	0,698	0,782	3,527	12	1,4	SNW 18 x 3 1/16	AN 18	W 18	HMVC 18E
	90	4 ²¹ /32	3,553	0,698	0,782	3,527	12	1,8	SNW 118 x 3 1/16	AN 18	W 18	HMVC 18E
3 1/4 82,55	90	4 ²¹ /32	2,645	0,698	0,782	3,527	12	1,4	SNW 18 x 3 1/4	AN 18	W 18	HMVC 18E
3 5/16 84,138	95	4 ¹⁵ /16	2,76	0,729	0,813	3,73	12	1,85	SNW 19 x 3 5/16	AN 19	W 19	HMVC 19E
	95	4 ¹⁵ /16	3,702	0,729	0,813	3,73	12	2,2	SNW 119 x 3 5/16	AN 19	W 19	HMVC 19E
3 7/16 87,313	100	5 ³ /16	2,869	0,76	0,844	3,918	12	2	SNW 20 x 3 7/16	AN 20	W 20	HMVC 20E
	100	5 ³ /16	3,971	0,76	0,844	3,918	12	2,85	SNW 120 x 3 7/16	AN 20	W 20	HMVC 20E
3 1/2 88,9	100	5 ³ /16	2,869	0,76	0,844	3,918	12	2	SNW 20 x 3 1/2	AN 20	W 20	HMVC 20E
	100	5 ³ /16	3,971	0,76	0,844	3,918	12	2,85	SNW 120 x 3 1/2	AN 20	W 20	HMVC 20E
3 11/16 93,663	105	5 ⁷ /16	2,987	0,76	0,844	4,122	12	2,05	SNW 21 x 3 11/16	AN 21	W 21	HMVC 21E
	110	5 ²³ /32	3,206	0,76	0,844	4,325	12	2,25	SNW 121 x 3 11/16	AN 21	W 21	HMVC 21E
3 5/8 100,03	110	5 ²³ /32	3,206	0,791	0,906	4,325	12	2,25	SNW 22 x 3 5/8	AN 22	W 22	HMVC 22E
	110	5 ²³ /32	4,348	0,791	0,906	4,325	12	2,95	SNW 122 x 3 5/8	AN 22	W 22	HMVC 22E
4 101,6	110	5 ²³ /32	3,206	0,791	0,906	4,325	12	2,25	SNW 22 x 4	AN 22	W 22	HMVC 22E
4 3/16 106,363	120	5 ¹¹ /16	2,947	0,823	0,938	4,716	12	2,8	SNW 3024 x 4 3/16	N 024	W 024	HMVC 24E
	120	5 ¹¹ /16	3,466	0,823	0,938	4,716	12	2,65	SNW 3124 x 4 3/16	N 024	W 024	HMVC 24E
	120	6 ¹ /8	3,466	0,823	0,938	4,716	12	3	SNW 24 x 4 3/16	AN 24	W 24	HMVC 24E
	120	6 ¹ /8	4,648	0,823	0,938	4,716	12	3,55	SNW 124 x 4 3/16	AN 24	W 24	HMVC 24E

16.3 Adapter sleeves with inch dimensions

d_1 4 1/4 – 8 in.

107,95 – 203,2 mm

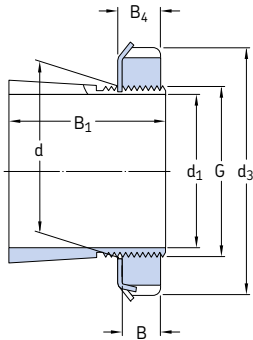

Principal dimensions							Thread	Mass	Designations	Appertaining		Appropriate
d_1	d	d_3	B_1	B	B_4	G	Threads per inch	Adapter sleeve with nut and locking device	lock nut	locking device	hydraulic nut	
in./mm	mm	in.				in.	–	kg	–			
4 1/4 107,95	120	5 11/16	3,466	0,823	0,938	4,716	12	2,65	SNW 3124 x 4 1/4 SNW 24 x 4 1/4	N 024	W 024	HMVC 24E
	120	6 1/8	3,466	0,823	0,938	4,716	12	3		AN 24	W 24	HMVC 24E
4 7/16 112,713	130	6 1/8	3,237	0,885	1	5,106	12	3,4	SNW 3026 x 4 7/16 SNW 3126 x 4 7/16 SNW 26 x 4 7/16 SNW 126 x 4 7/16	N 026	W 026	HMVC 26E
	130	6 3/8	3,762	0,885	1	5,106	12	3,8		N 026	W 026	HMVC 26E
	130	6 3/4	3,762	0,885	1	5,106	12	4,4		AN 26	W 26	HMVC 26E
	130	6 3/4	4,982	0,885	1	5,106	12	5,65		AN 26	W 26	HMVC 26E
4 1/2 114,3	130	6 1/8	3,237	0,885	1	5,106	12	3,4	SNW 3026 x 4 1/2 SNW 3126 x 4 1/2 SNW 26 x 4 1/2	N 026	W 026	HMVC 26E
	130	6 1/8	3,762	0,885	1	5,106	12	3,8		N 026	W 026	HMVC 26E
	130	6 3/4	3,762	0,885	1	5,106	12	4,4		AN 26	W 26	HMVC 26E
4 15/16 125,413	140	6 1/2	3,34	0,948	1,063	5,497	12	3,8	SNW 3028 x 4 15/16 SNW 3128 x 4 15/16 SNW 28 x 4 15/16 SNW 128 x 4 15/16	N 028	W 028	HMVC 28E
	140	6 1/2	3,981	0,948	1,063	5,497	12	4		N 028	W 028	HMVC 28E
	140	7 3/32	3,981	0,948	1,063	5,497	12	4,75		AN 28	W 28	HMVC 28E
	140	7 3/32	5,323	0,948	1,063	5,497	12	5,9		AN 28	W 28	HMVC 28E
5 127	140	6 1/2	3,34	0,948	1,063	5,497	12	3,85	SNW 3028 x 5 SNW 3128 x 5 SNW 28 x 5	N 028	W 028	HMVC 28E
	140	6 1/2	3,981	0,948	1,063	5,497	12	4		N 028	W 028	HMVC 28E
	140	7 3/32	3,981	0,948	1,063	5,497	12	4,75		AN 28	W 28	HMVC 28E
5 3/16 131,763	150	7 1/8	3,492	0,979	1,094	5,888	12	4,45	SNW 3030 x 5 3/16 SNW 3130 x 5 3/16 SNW 30 x 5 3/16 SNW 130 x 5 3/16	N 030	W 030	HMVC 30E
	150	7 1/8	4,241	0,979	1,094	5,888	12	6,2		N 030	W 030	HMVC 30E
	150	7 11/16	4,241	0,979	1,125	5,888	12	7,25		AN 30	W 30	HMVC 30E
	150	7 11/16	5,621	0,979	1,125	5,888	12	8,15		AN 30	W 30	HMVC 30E
5 1/4 133,35	150	7 11/16	4,241	0,979	1,125	5,888	12	7,25	SNW 30 x 5 1/4	AN 30	W 30	HMVC 30E
5 7/16 138,113	160	7 1/2	3,711	1,041	1,156	6,284	8	5,45	SNW 3032 x 5 7/16 SNW 3132 x 5 7/16 SNW 32 x 5 7/16 SNW 132 x 5 7/16	N 032	W 032	HMVC 32E
	160	7 1/2	4,578	1,041	1,156	6,284	8	6,1		N 032	W 032	HMVC 32E
	160	8 1/16	4,578	1,041	1,187	6,284	8	7,05		AN 32	W 32	HMVC 32E
	160	8 1/16	5,92	1,041	1,187	6,284	8	8,15		AN 32	W 32	HMVC 32E
5 3/4 146,05	160	8 1/16	4,578	1,041	1,187	6,284	8	7,05	SNW 32 x 5 3/4	AN 32	W 32	HMVC 32E

For oil injection variants, contact SKF.

Principal dimensions						Thread	Mass	Designations			Appertaining	Appropriate
d ₁	d	d ₃	B ₁	B	B ₄	G	Threads per inch	Adapter sleeve with nut and locking device	lock nut	locking device	hydraulic nut	
in./mm	mm	in.				in.	–	kg	–			
5¹⁵/₁₆ 150,813	170	7 ⁷ / ₈	4,019	1,073	1,188	6,659	8	6,1	SNW 3034 x 5 15/16	N 034	W 034	HMVC 34E
	170	7 ⁷ / ₈	4,847	1,073	1,188	6,659	8	7,3	SNW 3134 x 5 15/16	N 034	W 034	HMVC 34E
	170	8 ²¹ / ₃₂	4,847	1,073	1,219	6,659	8	8,85	SNW 34 x 5 15/16	AN 34	W 34	HMVC 34E
	170	8 ²¹ / ₃₂	6,188	1,073	1,219	6,659	8	9,55	SNW 134 x 5 15/16	AN 34	W 34	HMVC 34E
6 152,4	170	7 ⁷ / ₈	4,019	1,073	1,188	6,659	8	6,1	SNW 3034 x 6	N 034	W 034	HMVC 34E
	170	7 ⁷ / ₈	4,847	1,073	1,188	6,659	8	7,3	SNW 3134 x 6	N 034	W 034	HMVC 34E
	170	8 ²¹ / ₃₂	4,847	1,073	1,219	6,659	8	8,85	SNW 34 x 6	AN 34	W 34	HMVC 34E
	170	8 ²¹ / ₃₂	6,188	1,073	1,219	6,659	8	9,55	SNW 134 x 6	AN 34	W 34	HMVC 34E
6⁷/₁₆ 163,513	180	8 ¹ / ₄	4,337	1,104	1,219	7,066	8	6,8	SNW 3036 x 6 7/16	N 036	W 036	HMVC 36E
	180	8 ¹ / ₄	5,038	1,104	1,219	7,066	8	7,75	SNW 3136 x 6 7/16	N 036	W 036	HMVC 36E
	180	9 ¹ / ₁₆	5,038	1,104	1,25	7,066	8	9,3	SNW 36 x 6 7/16	AN 36	W 36	HMVC 36E
	180	9 ¹ / ₁₆	6,456	1,104	1,25	7,066	8	10	SNW 136 x 6 7/16	AN 36	W 36	HMVC 36E
6¹/₂ 165,1	180	8 ¹ / ₄	5,038	1,104	1,219	7,066	8	7,75	SNW 3136 x 6 1/2	N 036	W 036	HMVC 36E
	180	9 ¹ / ₁₆	5,038	1,104	1,25	7,066	8	9,3	SNW 36 x 6 1/2	AN 36	W 36	HMVC 36E
6¹⁵/₁₆ 176,213	190	8 ¹¹ / ₁₆	4,412	1,135	1,25	7,472	8	7,5	SNW 3038 x 6 15/16	N 038	W 038	HMVC 38E
	190	8 ¹¹ / ₁₆	5,261	1,135	1,25	7,472	8	8,95	SNW 3138 x 6 15/16	N 038	W 038	HMVC 38E
	190	9 ¹⁵ / ₃₂	5,261	1,135	1,281	7,472	8	10,5	SNW 38 x 6 15/16	AN 38	W 38	HMVC 38E
	190	9 ¹⁵ / ₃₂	6,758	1,135	1,281	7,472	8	12,5	SNW 138 x 6 15/16	AN 38	W 38	HMVC 38E
7 177,8	190	8 ¹¹ / ₁₆	4,412	1,135	1,25	7,472	8	7,5	SNW 3038 x 7	N 038	W 038	HMVC 38E
	190	8 ¹¹ / ₁₆	5,261	1,135	1,25	7,472	8	8,95	SNW 3138 x 7	N 038	W 038	HMVC 38E
	190	9 ¹⁵ / ₃₂	5,261	1,135	1,281	7,472	8	10,5	SNW 38 x 7	AN 38	W 38	HMVC 38E
	190	9 ¹⁵ / ₃₂	6,758	1,135	1,281	7,472	8	12,5	SNW 138 x 7	AN 38	W 38	HMVC 38E
7³/₁₆ 182,563	200	9 ⁷ / ₁₆	4,75	1,198	1,313	7,847	8	8,85	SNW 3040 x 7 3/16	N 040	W 040	HMVC 40E
	200	9 ⁷ / ₁₆	5,484	1,198	1,313	7,847	8	13	SNW 3140 x 7 3/16	N 040	W 040	HMVC 40E
	200	9 ²⁷ / ₃₂	5,484	1,198	1,344	7,847	8	14	SNW 40 x 7 3/16	AN 40	W 40	HMVC 40E
	200	9 ²⁷ / ₃₂	7,095	1,198	1,344	7,847	8	16	SNW 140 x 7 3/16	AN 40	W 40	HMVC 40E
7¹⁵/₁₆ 201,613	220	10 ¹ / ₄	5,13	1,26	1,375	8,628	8	11	SNW 3044 x 7 15/16	N 044	W 044	HMVC 44E
	220	10 ¹ / ₄	5,901	1,26	1,375	8,628	8	13	SNW 3144 x 7 15/16	N 044	W 044	HMVC 44E
	220	11	5,901	1,26	1,406	8,628	8	14,5	SNW 44 x 7 15/16	N 44	W 44	HMVC 44E
	220	11	7,287	1,26	1,406	8,628	8	21	SNW 144 x 7 15/16	N 44	W 44	HMVC 44E
8 203,2	220	10 ¹ / ₄	5,13	1,26	1,375	8,628	8	11	SNW 3044 x 8	N 044	W 044	HMVC 44E
	220	10 ¹ / ₄	5,901	1,26	1,375	8,628	8	13	SNW 3144 x 8	N 044	W 044	HMVC 44E
	220	11	5,901	1,26	1,406	8,628	8	14,5	SNW 44 x 8	N 44	W 44	HMVC 44E

For oil injection variants, contact SKF.

16.3 Adapter sleeves with inch dimensions

d_1 8 15/16 – 19 1/2 in.

227,013 – 495,3 mm

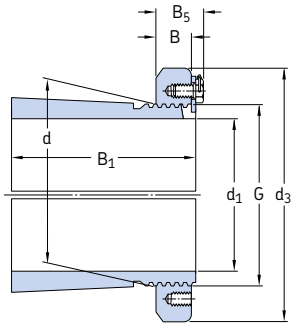

Principal dimensions					Thread		Mass	Designations	Appertaining locking device			Appropriate hydraulic nut
d_1	d	d_3	B_1	B	B_5	G	Threads per inch	Adapter sleeve with nut and locking device	Appertaining lock nut	locking device		
in./mm	mm	in.				in.	–	kg	–			
8 15/16 227,013	240	117/16	5,432	1,354	1,69	9,442	6	14,5	SNP 3048 x 8 15/16	N 048	PL 48	HMVC 48E
	240	117/16	6,638	1,354	1,69	9,442	6	17	SNP 3148 x 8 15/16	N 048	PL 48	HMVC 48E
	240	117/16	8,109	1,354	1,69	9,442	6	22	SNP 148 x 8 15/16	N 048	PL 48	HMVC 48E
9 7/16 239,713	260	12 3/16	6,019	1,416	1,752	10,192	6	18,5	SNP 3052 x 9 7/16	N 052	PL 52	HMVC 52E
	260	12 3/16	7,593	1,416	1,752	10,192	6	20	SNP 3152 x 9 7/16	N 052	PL 52	HMVC 52E
	260	12 3/16	8,744	1,416	1,752	10,192	6	25	SNP 152 x 9 7/16	N 052	PL 52	HMVC 52E
9 1/2 241,3	260	12 3/16	6,019	1,416	1,752	10,192	6	18,5	SNP 3052 x 9 1/2	N 052	PL 52	HMVC 52E
	260	12 3/16	7,593	1,416	1,752	10,192	6	20	SNP 3152 x 9 1/2	N 052	PL 52	HMVC 52E
9 15/16 252,413	280	13	6,191	1,51	1,846	11,004	6	20,5	SNP 3056 x 9 15/16	N 056	PL 56	HMVC 56E
	280	13	7,766	1,51	1,846	11,004	6	21	SNP 3156 x 10	N 056	PL 56	HMVC 56E
10 7/16 265,113	280	13	6,191	1,51	1,846	11,004	6	20,5	SNP 3056 x 10 7/16	N 056	PL 56	HMVC 56E
	280	13	8,947	1,51	1,846	11,004	6	27	SNP 3256 x 10 7/16	N 056	PL 56	HMVC 56E
10 1/2 266,7	280	13	6,191	1,51	1,846	11,004	6	20,5	SNP 3056 x 10 1/2	N 056	PL 56	HMVC 56E
10 15/16 277,813	300	14 3/16	6,727	1,573	1,941	11,785	6	27	SNP 3060 x 10 15/16	N 060	PL 60	HMVC 60E
	300	14 3/16	8,38	1,573	1,941	11,785	6	27	SNP 3160 x 10 15/16	N 060	PL 60	HMVC 60E
	300	14 3/16	9,64	1,573	1,941	11,785	6	31	SNP 3260 x 10 15/16	N 060	PL 60	HMVC 60E
11 279,4	300	14 3/16	6,727	1,573	1,941	11,785	6	27	SNP 3060 x 11	N 060	PL 60	HMVC 60E
	300	14 3/16	9,64	1,573	1,941	11,785	6	31	SNP 3260 x 11	N 060	PL 60	HMVC 60E
11 1/2 292,1	320	15	6,946	1,666	2,034	12,562	6	29,5	SNP 3064 x 11 1/2	N 064	PL 64	HMVC 60E
11 15/16 303,213	320	15	6,946	1,666	2,034	12,562	6	29,5	SNP 3064 x 11 15/16	N 064	PL 64	HMVC 64E
	320	15	10,371	1,666	2,034	12,562	6	44,5	SNP 3264 x 11 15/16	N 064	PL 64	HMVC 64E
12 304,8	320	15	6,946	1,666	2,034	12,562	6	29,5	SNP 3064 x 12	N 064	PL 64	HMVC 64E
	320	15	9,111	1,666	2,034	12,562	6	33,5	SNP 3164 x 12	N 064	PL 64	HMVC 64E
	320	15	10,371	1,666	2,034	12,562	6	44,5	SNP 3264 x 12	N 064	PL 64	HMVC 64E

For oil injection variants, contact SKF.

Principal dimensions						Thread	Mass	Designations	Appertaining	locking	Appro-	
d ₁	d	d ₃	B ₁	B	B ₅	G	Threads per inch	Adapter sleeve with nut and locking device	lock nut	device	prate hydraulic nut	
in./mm	mm	in.				in.	–	kg	–			
12 7/16 315,913	340	15 3/4	7,543	1,791	2,159	13,303	5	35,5	SNP 3068 x 12 7/16	N 068	PL 68	HMVC 68E
	340	15 3/4	9,787	1,791	2,159	13,303	5	42,5	SNP 3168 x 12 7/16	N 068	PL 68	HMVC 68E
	340	15 3/4	11,126	1,791	2,159	13,303	5	47,5	SNP 3268 x 12 7/16	N 068	PL 68	HMVC 68E
13 7/16 341,313	360	16 1/2	7,579	1,791	2,159	14,134	5	39	SNP 3072 x 13 7/16	N 072	PL 72	HMVC 72E
	360	16 1/2	9,862	1,791	2,159	14,134	5	54,5	SNP 3172 x 13 7/16	N 072	PL 72	HMVC 72E
	360	16 1/2	11,437	1,791	2,159	14,134	5	61,5	SNP 3272 x 13 7/16	N 072	PL 72	HMVC 72E
13 15/16 354,013	380	17 3/4	7,743	1,916	2,364	14,921	5	43	SNP 3076 x 13 15/16	N 076	PL 76	HMVC 76E
	380	17 3/4	10,066	1,916	2,364	14,921	5	57	SNP 3176 x 13 15/16	N 076	PL 76	HMVC 76E
	380	17 3/4	11,877	1,916	2,364	14,921	5	66	SNP 3276 x 13 15/16	N 076	PL 76	HMVC 76E
14 355,6	380	17 3/4	7,743	1,916	2,364	14,921	5	43	SNP 3076 x 14	N 076	PL 76	HMVC 76E
	400	18 1/2	10,066	1,916	2,364	14,921	5	57	SNP 3176 x 14	N 076	PL 76	HMVC 76E
	380	17 3/4	11,877	1,916	2,364	14,921	5	66	SNP 3276 x 14	N 076	PL 76	HMVC 76E
15 381	400	18 1/2	8,411	2,073	2,521	15,709	5	45,5	SNP 3080 x 15	N 080	PL 80	HMVC 80E
	400	18 1/2	10,459	2,073	2,521	15,709	5	63,5	SNP 3180 x 15	N 080	PL 80	HMVC 80E
	400	18 1/2	12,664	2,073	2,521	15,709	5	75	SNP 3280 x 15	N 080	PL 80	HMVC 80E
15 3/4 400,05	420	19 5/16	8,498	2,073	2,521	16,496	5	47,5	SNP 3084 x 15 3/4	N 084	PL 84	HMVC 84E
	420	19 5/16	11,412	2,073	2,521	16,496	5	66	SNP 3184 x 15 3/4	N 084	PL 84	HMVC 84E
	420	19 5/16	13,302	2,073	2,521	16,496	5	75	SNP 3284 x 15 3/4	N 084	PL 84	HMVC 84E
16 1/2 419,1	440	20 1/2	9,1	2,385	2,913	17,283	5	59	SNP 3088 x 16 1/2	N 088	PL 88	HMVC 88E
	440	20 1/2	11,817	2,385	2,913	17,283	5	68,5	SNP 3188 x 16 1/2	N 088	PL 88	HMVC 88E
	440	20 1/2	13,943	2,385	2,913	17,283	5	86,5	SNP 3288 x 16 1/2	N 088	PL 88	HMVC 88E
17 431,8	460	21 1/4	9,336	2,385	2,913	18,071	5	71,5	SNP 3092 x 17	N 092	PL 92	HMVC 92E
	460	21 1/4	12,368	2,385	2,913	18,071	5	95	SNP 3192 x 17	N 092	PL 92	HMVC 92E
18 457,2	480	22 1/16	9,446	2,385	2,944	18,858	5	75	SNP 3096 x 18	N 096	PL 96	HMVC 96E
	480	22 1/16	12,714	2,385	2,944	18,858	5	91,5	SNP 3196 x 18	N 096	PL 96	HMVC 96E
18 1/2 469,9	500	22 13/16	9,838	2,703	3,262	19,646	5	91	SNP 30/500 x 18 1/2	N 500	PL 500	HMVC 100E
19 1/2 495,3	530	24 13/16	10,679	2,703	3,262	20,827	4	120	SNP 30/530 x 19 1/2	N 530	PL 530	HMVC 106E

For oil injection variants, contact SKF.

16.4 Withdrawal sleeves

d_1 35 – 170 mm

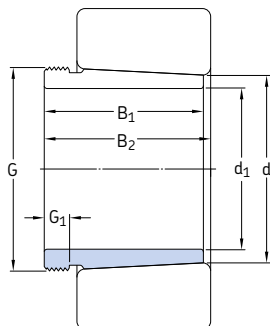

Principal dimensions						Mass	Designations	Appropriate nut for dis-mounting	hydraulic nut
d_1	d	B_1	$B_2^{1)}$	G	G_1	Withdrawal sleeve			
mm						kg	–		
35	40	29	32	M 45x1,5	6	0,09	AH 308	KM 9	–
	40	40	43	M 45x1,5	7	0,13	AH 2308	KM 9	–
40	45	31	34	M 50x1,5	6	0,12	AH 309	KM 10	HMV 10 E
	45	44	47	M 50x1,5	7	0,16	AH 2309	KM 10	HMV 10 E
45	50	35	38	M 55x2	7	0,13	AHX 310	KM 11	HMV 11 E
	50	50	53	M 55x2	9	0,19	AHX 2310	KM 11	HMV 11 E
50	55	37	40	M 60x2	7	0,16	AHX 311	KM 12	HMV 12 E
	55	54	57	M 60x2	10	0,26	AHX 2311	KM 12	HMV 12 E
55	60	40	43	M 65x2	8	0,19	AHX 312	KM 13	HMV 13 E
	60	58	61	M 65x2	11	0,3	AHX 2312	KM 13	HMV 13 E
60	65	42	45	M 70x2	8	0,22	AH 313 G	KM 14	HMV 14 E
	65	61	64	M 70x2	12	0,36	AH 2313 G	KM 14	HMV 14 E
65	70	43	47	M 75x2	8	0,24	AH 314 G	KM 15	HMV 15 E
	70	64	68	M 75x2	12	0,42	AHX 2314 G	KM 15	HMV 15 E
70	75	45	49	M 80x2	8	0,29	AH 315 G	KM 16	HMV 16 E
	75	68	72	M 80x2	12	0,48	AHX 2315 G	KM 16	HMV 16 E
75	80	48	52	M 90x2	8	0,37	AH 316	KM 18	HMV 18 E
	80	71	75	M 90x2	12	0,57	AHX 2316	KM 18	HMV 18 E
80	85	52	56	M 95x2	9	0,43	AHX 317	KM 19	HMV 19 E
	85	74	78	M 95x2	13	0,65	AHX 2317	KM 19	HMV 19 E
85	90	53	57	M 100x2	9	0,46	AHX 318	KM 20	HMV 20 E
	90	63	67	M 100x2	10	0,57	AHX 3218	KM 20	HMV 20 E
	90	79	83	M 100x2	14	0,76	AHX 2318	KM 20	HMV 20 E
90	95	57	61	M 105x2	10	0,54	AHX 319	KM 21	HMV 21 E
	95	85	89	M 105x2	16	0,9	AHX 2319	KM 21	HMV 21 E

¹⁾ Width before the sleeve is driven into the bearing bore.

Principal dimensions						Mass	Designations	Appropriate nut for dis-	hydraulic
d ₁	d	B ₁	B ₂ ¹⁾	G	G ₁		Withdrawal sleeve	mounting	nut
mm						kg	-		
95	100	59	63	M110x2	10	0,58	AHX 320	KM 22	HMV 22 E
	100	64	68	M110x2	11	0,66	AHX 3120	KM 22	HMV 22 E
	100	73	77	M110x2	11	0,76	AHX 3220	KM 22	HMV 22 E
	100	90	94	M110x2	16	1	AHX 2320	KM 22	HMV 22 E
105	110	63	67	M120x2	12	0,77	AHX 322	KM 24	HMV 24 E
	110	68	72	M120x2	11	0,76	AHX 3122	KM 24	HMV 24 E
	110	82	86	M120x2	11	1	AHX 3222 G	KM 24	HMV 24 E
	110	82	91	M115x2	13	0,71	AH 24122	KM 23	HMV 23 E
	110	98	102	M120x2	16	1,3	AHX 2322 G	KM 24	HMV 24 E
115	120	60	64	M130x2	13	0,73	AHX 3024	KM 26	HMV 26 E
	120	73	82	M125x2	13	0,7	AH 24024	KM 25	HMV 25 E
	120	75	79	M130x2	12	0,94	AHX 3124	KM 26	HMV 26 E
	120	90	94	M130x2	13	1,7	AHX 3224 G	KM 26	HMV 26 E
	120	93	102	M130x2	13	1	AH 24124	KM 26	HMV 26 E
	120	105	109	M130x2	17	1,55	AHX 2324 G	KM 26	HMV 26 E
125	130	67	71	M140x2	14	0,91	AHX 3026	KM 28	HMV 28 E
	130	78	82	M140x2	12	1,1	AHX 3126	KM 28	HMV 28 E
	130	83	93	M135x2	14	0,88	AH 24026	KM 27	HMV 27 E
	130	94	104	M140x2	14	1,15	AH 24126	KM 28	HMV 28 E
	130	98	102	M140x2	15	1,5	AHX 3226 G	KM 28	HMV 28 E
	130	115	119	M140x2	19	1,85	AHX 2326 G	KM 28	HMV 28 E
135	140	68	73	M150x2	14	1	AHX 3028	KM 30	HMV 30 E
	140	83	88	M150x2	14	1,3	AHX 3128	KM 30	HMV 30 E
	140	83	93	M145x2	14	0,95	AH 24028	KM 29	HMV 29 E
	140	99	109	M150x2	14	1,3	AH 24128	KM 30	HMV 30 E
	140	104	109	M150x2	15	1,75	AHX 3228 G	KM 30	HMV 30 E
	140	125	130	M150x2	20	2,25	AHX 2328 G	KM 30	HMV 30 E
145	150	72	77	M160x3	15	1,15	AHX 3030	KM 32	HMV 32 E
	150	90	101	M155x3	15	1,05	AH 24030	KM 31	HMV 31 E
	150	96	101	M160x3	15	1,7	AHX 3130 G	KM 32	HMV 32 E
	150	114	119	M160x3	17	2,1	AHX 3230 G	KM 32	HMV 32 E
	150	115	126	M160x3	15	1,55	AH 24130	KM 32	HMV 32 E
	150	135	140	M160x3	24	3,7	AHX 2330 G	KM 32	HMV 32 E
150	160	77	82	M170x3	16	2	AH 3032	KM 34	HMV 34 E
	160	95	106	M170x3	15	2,3	AH 24032	KM 34	HMV 34 E
	160	103	108	M170x3	16	3	AH 3132 G	KM 34	HMV 34 E
	160	124	130	M170x3	20	3,7	AH 3232 G	KM 34	HMV 34 E
	160	124	135	M170x3	15	3	AH 24132	KM 34	HMV 34 E
	160	140	146	M170x3	24	4,35	AH 2332 G	KM 34	HMV 34 E
160	170	85	90	M180x3	17	2,45	AH 3034	KM 36	HMV 36 E
	170	104	109	M180x3	16	3,2	AH 3134 G	KM 36	HMV 36 E
	170	106	117	M180x3	16	2,7	AH 24034	KM 36	HMV 36 E
	170	125	136	M180x3	16	3,25	AH 24134	KM 36	HMV 36 E
	170	134	140	M180x3	24	4,35	AH 3234 G	KM 36	HMV 36 E
	170	146	152	M180x3	24	4,85	AH 2334 G	KM 36	HMV 36 E
170	180	92	98	M190x3	17	2,8	AH 3036	KM 38	HMV 38 E
	180	105	110	M190x3	17	3,4	AH 2236 G	KM 38	HMV 38 E
	180	116	122	M190x3	19	3,9	AH 3136 G	KM 38	HMV 38 E
	180	116	127	M190x3	16	3,2	AH 24036	KM 38	HMV 38 E
	180	134	145	M190x3	16	3,75	AH 24136	KM 38	HMV 38 E
	180	140	146	M190x3	24	4,85	AH 3236 G	KM 38	HMV 38 E
	180	154	160	M190x3	26	5,5	AH 2336 G	KM 38	HMV 38 E

¹⁾ Width before the sleeve is driven into the bearing bore.

16.4 Withdrawal sleeves

d_1 180 – 440 mm

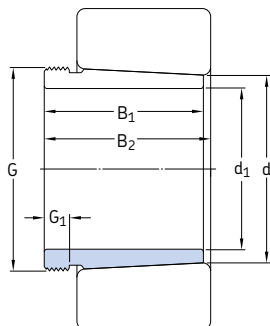

AH

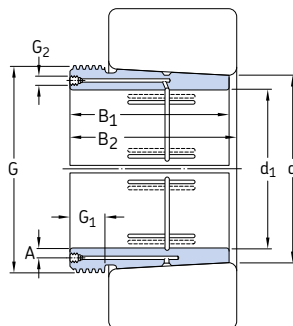

AOH

Principal dimensions							Mass	Designations	Appropriate nut for dismounting	hydraulic nut	
d_1	d	B_1	$B_2^{1)}$	G	G_1	G_2	A	Withdrawal sleeve			
mm						in.	mm	kg	-		
180	190	96	102	M 200x3	18	-	-	3,3	AH 3038 G	KM 40	HMV 40 E
	190	112	117	M 200x3	18	-	-	3,9	AH 2238 G	KM 40	HMV 40 E
	190	118	131	M 200x3	18	-	-	3,55	AH 24038	KM 40	HMV 40 E
	190	125	131	M 200x3	20	-	-	4,5	AH 3138 G	KM 40	HMV 40 E
	190	145	152	M 200x3	25	-	-	5,4	AH 3238 G	KM 40	HMV 40 E
	190	146	159	M 200x3	18	-	-	4,45	AH 24138	KM 40	HMV 40 E
190	160	167	M 200x3	26	-	-	6,1	AH 2338 G	KM 40	HMV 40 E	
190	200	102	108	Tr 210x4	19	-	-	3,7	AH 3040 G	HM 42 T	HMV 42 E
	200	127	140	Tr 210x4	18	-	-	4	AH 24040	HM 42 T	HMV 42 E
	200	134	140	Tr 220x4	21	-	-	5,65	AH 3140	HM 3044	HMV 44 E
	200	153	160	Tr 220x4	25	-	-	6,6	AH 3240	HM 3044	HMV 44 E
	200	158	171	Tr 210x4	18	-	-	5,05	AH 24140	HM 42 T	HMV 42 E
	200	170	177	Tr 220x4	30	-	-	7,6	AH 2340	HM 3044	HMV 44 E
200	220	111	117	Tr 230x4	20	G 1/8	6,5	7,3	AOH 3044 G	HM 46 T	HMV 46 E
	220	138	152	Tr 230x4	20	G 1/8	6,5	7,45	AOH 24044	HM 46 T	HMV 46 E
	220	145	151	Tr 240x4	23	G 1/4	9	9,3	AOH 3144	HM 3048	HMV 48 E
	220	170	184	Tr 230x4	20	G 1/8	6,5	10	AOH 24144	HM 46 T	HMV 46 E
	220	181	189	Tr 240x4	30	G 1/4	9	13,5	AOH 2344	HM 3048	HMV 48 E
220	240	116	123	Tr 260x4	21	G 1/4	9	7,95	AOH 3048	HM 3052	HMV 52 E
	240	138	153	Tr 250x4	20	G 1/8	6,5	8,05	AOH 24048	HM 50 T	HMV 50 E
	240	154	161	Tr 260x4	25	G 1/4	9	12	AOH 3148	HM 3052	HMV 52 E
	240	180	195	Tr 260x4	20	G 1/4	9	11,5	AOH 24148	HM 3052	HMV 52 E
	240	189	197	Tr 260x4	30	G 1/4	9	14	AOH 2348	HM 3052	HMV 52 E
240	260	128	135	Tr 280x4	23	G 1/4	9	9,55	AOH 3052	HM 3056	HMV 56 E
	260	155	161	Tr 280x4	23	G 1/4	9	13,5	AOH 2252 G	HM 3056	HMV 56 E
	260	162	178	Tr 280x4	22	G 1/8	6,5	12,5	AOH 24052 G	HM 3056	HMV 56 E
	260	172	179	Tr 280x4	26	G 1/4	9	15,5	AOH 3152 G	HM 3056	HMV 56 E
	260	202	218	Tr 280x4	22	G 1/4	9	14	AOH 24152	HM 3056	HMV 56 E
	260	205	213	Tr 280x4	30	G 1/4	9	19	AOH 2352 G	HM 3056	HMV 56 E

¹⁾ Width before the sleeve is driven into the bearing bore.

Principal dimensions							Mass	Designations	Appropriate nut for dis-mounting	hydraulic nut	
d ₁	d	B ₁	B ₂ ¹⁾	G	G ₁	G ₂	A	Withdrawal sleeve			
mm						in.	mm	kg	-		
260	280	131	139	Tr 300x4	24	G 1/4	9	11	AOH 3056	HM 3060	HMV 60 E
	280	155	163	Tr 300x4	24	G 1/4	9	15	AOH 2256 G	HM 3160	HMV 60 E
	280	162	179	Tr 300x4	22	G 1/8	6,5	13,5	AOH 24056 G	HM 3160	HMV 60 E
	280	175	183	Tr 300x4	28	G 1/4	9	17	AOH 3156 G	HM 3160	HMV 60 E
	280	202	219	Tr 300x4	22	G 1/4	9	15	AOH 24156	HM 3160	HMV 60 E
	280	212	220	Tr 300x4	30	G 1/4	9	21,5	AOH 2356 G	HM 3160	HMV 60 E
280	300	145	153	Tr 320x5	26	G 1/4	9	13	AOH 3060	HM 3064	HMV 64 E
	300	170	178	Tr 320x5	26	G 1/4	9	17,5	AOH 2260 G	HM 3164	HMV 64 E
	300	184	202	Tr 320x5	24	G 1/8	6,5	17	AOH 24060 G	HM 3164	HMV 64 E
	300	192	200	Tr 320x5	30	G 1/4	9	20,5	AOH 3160 G	HM 3164	HMV 64 E
	300	224	242	Tr 320x5	24	G 1/4	9	18,5	AOH 24160	HM 3164	HMV 64 E
	300	228	236	Tr 320x5	34	G 1/4	9	23,5	AOH 3260 G	HM 3164	HMV 64 E
300	320	149	157	Tr 340x5	27	G 1/4	9	16,5	AOH 3064 G	HM 3068	HMV 68 E
	320	180	190	Tr 340x5	27	G 1/4	9	20	AOH 2264 G	HM 3168	HMV 68 E
	320	184	202	Tr 340x5	24	G 1/8	6,5	18	AOH 24064 G	HM 3168	HMV 68 E
	320	209	217	Tr 340x5	31	G 1/4	9	24,5	AOH 3164 G	HM 3168	HMV 68 E
	320	242	260	Tr 340x5	24	G 1/4	9	20,5	AOH 24164	HM 3168	HMV 68 E
	320	246	254	Tr 340x5	36	G 1/4	9	27,5	AOH 3264 G	HM 3168	HMV 68 E
320	340	162	171	Tr 360x5	28	G 1/4	9	19	AOH 3068 G	HM 3072	HMV 72 E
	340	206	225	Tr 360x5	26	G 1/4	9	18	AOH 24068	HM 3172	HMV 72 E
	340	225	234	Tr 360x5	33	G 1/4	9	28,5	AOH 3168 G	HM 3172	HMV 72 E
	340	264	273	Tr 360x5	38	G 1/4	9	32	AOH 3268 G	HM 3172	HMV 72 E
	340	269	288	Tr 360x5	26	G 1/4	9	25,5	AOH 24168	HM 3172	HMV 72 E
	340	360	167	176	Tr 380x5	30	G 1/4	9	21	AOH 3072 G	HM 3076
360		206	226	Tr 380x5	26	G 1/4	9	20	AOH 24072	HM 3176	HMV 76 E
360		229	238	Tr 380x5	35	G 1/4	9	30,5	AOH 3172 G	HM 3176	HMV 76 E
360		269	289	Tr 380x5	26	G 1/4	9	26	AOH 24172	HM 3176	HMV 76 E
360		274	283	Tr 380x5	40	G 1/4	9	35,5	AOH 3272 G	HM 3176	HMV 76 E
360		380	170	180	Tr 400x5	31	G 1/4	9	22,5	AOH 3076 G	HM 3080
	380	208	228	Tr 400x5	28	G 1/4	9	23,5	AOH 24076	HM 3180	HMV 80 E
	380	232	242	Tr 400x5	36	G 1/4	9	33	AOH 3176 G	HM 3180	HMV 80 E
	380	271	291	Tr 400x5	28	G 1/4	9	31	AOH 24176	HM 3180	HMV 80 E
	380	284	294	Tr 400x5	42	G 1/4	9	42	AOH 3276 G	HM 3180	HMV 80 E
	380	400	183	193	Tr 420x5	33	G 1/4	9	26	AOH 3080 G	HM 3084
400		228	248	Tr 420x5	28	G 1/4	9	27	AOH 24080	HM 3184	HMV 84 E
400		240	250	Tr 420x5	38	G 1/4	9	36	AOH 3180 G	HM 3184	HMV 84 E
400		278	298	Tr 420x5	28	G 1/4	9	35	AOH 24180	HM 3184	HMV 84 E
400		302	312	Tr 420x5	44	G 1/4	9	48	AOH 3280 G	HM 3184	HMV 84 E
400		420	186	196	Tr 440x5	34	G 1/4	9	28	AOH 3084 G	HM 3088
	420	230	252	Tr 440x5	30	G 1/4	9	29	AOH 24084	HM 3188	HMV 88 E
	420	266	276	Tr 440x5	40	G 1/4	9	43	AOH 3184 G	HM 3188	HMV 88 E
	420	310	332	Tr 440x5	30	G 1/4	9	39	AOH 24184	HM 3188	HMV 88 E
	420	321	331	Tr 440x5	46	G 1/4	9	54,5	AOH 3284 G	HM 3188	HMV 88 E
	420	440	194	205	Tr 460x5	35	G 1/4	9	31	AOHX 3088 G	HM 3092
440		242	264	Tr 460x5	30	G 1/4	9	32	AOH 24088	HM 3192	HMV 92 E
440		270	281	Tr 460x5	42	G 1/4	9	46	AOHX 3188 G	HM 3192	HMV 92 E
440		310	332	Tr 460x5	30	G 1/4	9	45,5	AOH 24188	HM 3192	HMV 92 E
440		330	341	Tr 460x5	48	G 1/4	9	59	AOHX 3288 G	HM 3192	HMV 92 E
440		460	202	213	Tr 480x5	37	G 1/4	9	34	AOHX 3092 G	HM 3096
	460	250	273	Tr 480x5	32	G 1/4	9	34,5	AOH 24092	HM 3196	HMV 96 E
	460	285	296	Tr 480x5	43	G 1/4	9	51,5	AOHX 3192 G	HM 3196	HMV 96 E
	460	332	355	Tr 480x5	32	G 1/4	9	50	AOH 24192	HM 3196	HMV 96 E
	460	349	360	Tr 480x5	50	G 1/4	9	66,5	AOHX 3292 G	HM 3196	HMV 96 E

¹⁾ Width before the sleeve is driven into the bearing bore.

16.4 Withdrawal sleeves

d_1 460 – 1 000 mm

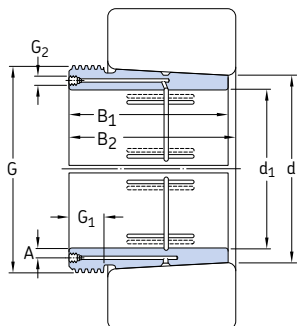

AOH

Principal dimensions								Mass	Designations	Appropriate nut for dismounting	hydraulic nut
d_1	d	B_1	$B_2^{1)}$	G	G_1	G_2	A	Withdrawal sleeve			
mm						in.	mm	kg	-		
460	480	205	217	Tr 500x5	38	G 1/4	9	34	AOHX 3096 G	HM 30/500	HMV 100 E
	480	250	273	Tr 500x5	32	G 1/4	9	36,5	A0H 24096	HM 31/500	HMV 100 E
	480	295	307	Tr 500x5	45	G 1/4	9	56	AOHX 3196 G	HM 31/500	HMV 100 E
	480	340	363	Tr 500x5	32	G 1/4	9	51,5	A0H 24196	HM 31/500	HMV 100 E
	480	364	376	Tr 500x5	52	G 1/4	9	73,5	AOHX 3296 G	HM 31/500	HMV 100 E
480	500	209	221	Tr 530x6	40	G 1/4	9	41	AOHX 30/500 G	HM 30/530	HMV 106 E
	500	253	276	Tr 530x6	35	G 1/4	9	43	A0H 240/500	HM 31/530	HMV 106 E
	500	313	325	Tr 530x6	47	G 1/4	9	66,5	AOHX 31/500 G	HM 31/530	HMV 106 E
	500	360	383	Tr 530x6	35	G 1/4	9	62,5	A0H 241/500	HM 31/530	HMV 106 E
	500	393	405	Tr 530x6	54	G 1/4	9	89,5	AOHX 32/500 G	HM 31/530	HMV 106 E
500	530	230	242	Tr 560x6	45	G 1/4	10	63,5	A0H 30/530	HM 30/560	HMV 112 E
	530	285	309	Tr 560x6	35	G 1/4	9	64,5	A0H 240/530 G	HM 31/560	HMV 112 E
	530	325	337	Tr 560x6	53	G 1/4	10	93,5	A0H 31/530	HM 31/560	HMV 112 E
	530	370	394	Tr 560x6	35	G 1/4	9	92	A0H 241/530 G	HM 31/560	HMV 112 E
	530	412	424	Tr 560x6	57	G 1/4	10	127	A0H 32/530 G	HM 31/560	HMV 112 E
530	560	240	252	Tr 600x6	45	G 1/4	11	73,5	AOHX 30/560	HM 30/600	HMV 120 E
	560	296	320	Tr 600x6	38	G 1/4	9	79,5	A0H 240/560 G	HM 31/600	HMV 120 E
	560	335	347	Tr 600x6	55	G 1/4	11	107	A0H 31/560	HM 31/600	HMV 120 E
	560	393	417	Tr 600x6	38	G 1/4	9	107	A0H 241/560 G	HM 31/600	HMV 120 E
	560	422	434	Tr 600x6	57	G 1/4	11	143	AOHX 32/560	HM 31/600	HMV 120 E
570	600	245	259	Tr 630x6	45	G 1/4	11	77	AOHX 30/600	HM 30/630	HMV 126 E
	600	310	336	Tr 630x6	38	G 1/4	9	86,5	AOHX 240/600	HM 31/630	HMV 126 E
	600	355	369	Tr 630x6	55	G 1/4	11	120	AOHX 31/600	HM 31/630	HMV 126 E
	600	413	439	Tr 630x6	38	G 1/4	9	118	A0H 241/600	HM 31/630	HMV 126 E
	600	445	459	Tr 630x6	57	G 1/4	11	159	AOHX 32/600 G	HM 31/630	HMV 126 E
600	630	258	272	Tr 670x6	46	G 1/4	11	88,5	A0H 30/630	HM 30/670	HMV 134 E
	630	330	356	Tr 670x6	40	G 1/4	9	101	A0H 240/630 G	HM 31/670	HMV 134 E
	630	375	389	Tr 670x6	60	G 1/4	11	139	A0H 31/630	HM 31/670	HMV 134 E
	630	440	466	Tr 670x6	40	G 1/4	9	139	A0H 241/630 G	HM 31/670	HMV 134 E
	630	475	489	Tr 670x6	63	G 1/4	11	188	A0H 32/630 G	HM 31/670	HMV 134 E

¹⁾ Width before the sleeve is driven into the bearing bore.

Principal dimensions								Mass	Designations	Appropriate nut for dis-mounting	hydraulic nut
d ₁	d	B ₁	B ₂ ¹⁾	G	G ₁	G ₂	A	Withdrawal sleeve			
mm	mm	mm	mm	mm	mm	in.	mm	kg	–		
630	670	280	294	Tr 710x7	50	G 1/4	12	125	AOH 30/670	HM 30/710	HMV 142 E
	670	348	374	Tr 710x7	40	G 1/4	12	141	AOH 240/670 G	HM 31/710	HMV 142 E
	670	395	409	Tr 710x7	59	G 1/4	12	189	AOHX 31/670	HM 31/710	HMV 142 E
	670	452	478	Tr 710x7	40	G 1/4	12	185	AOH 241/670	HM 31/710	HMV 142 E
	670	500	514	Tr 710x7	62	G 1/4	12	252	AOH 32/670 G	HM 31/710	HMV 142 E
670	710	286	302	Tr 750x7	50	G 1/4	15	139	AOHX 30/710	HM 30/750	HMV 150 E
	710	360	386	Tr 750x7	45	G 1/4	12	155	AOH 240/710 G	HM 31/750	HMV 150 E
	710	405	421	Tr 750x7	60	G 1/4	15	207	AOHX 31/710	HM 31/750	HMV 150 E
	710	483	509	Tr 750x7	45	G 1/4	12	212	AOH 241/710	HM 31/750	HMV 150 E
	710	515	531	Tr 750x7	65	G 1/4	15	278	AOH 32/710 G	HM 31/750	HMV 150 E
710	750	300	316	Tr 800x7	50	G 1/4	15	145	AOH 30/750	HM 30/800	HMV 160 E
	750	380	408	Tr 800x7	45	G 1/4	12	179	AOH 240/750 G	HM 31/800	HMV 160 E
	750	425	441	Tr 800x7	60	G 1/4	15	238	AOH 31/750	HM 31/800	HMV 160 E
	750	520	548	Tr 800x7	45	G 1/4	12	248	AOH 241/750 G	HM 31/800	HMV 160 E
	750	540	556	Tr 800x7	65	G 1/4	15	320	AOH 32/750	HM 31/800	HMV 160 E
750	800	308	326	Tr 850x7	50	G 1/4	15	204	AOH 30/800	HM 30/850	HMV 170 E
	800	395	423	Tr 850x7	50	G 1/4	15	237	AOH 240/800 G	HM 31/850	HMV 170 E
	800	438	456	Tr 850x7	63	G 1/4	15	305	AOH 31/800	HM 31/850	HMV 170 E
	800	525	553	Tr 850x7	50	G 1/4	15	318	AOH 241/800 G	HM 31/850	HMV 170 E
	800	550	568	Tr 850x7	67	G 1/4	15	401	AOH 32/800	HM 31/850	HMV 170 E
800	850	325	343	Tr 900x7	53	G 1/4	15	230	AOH 30/850	HM 30/900	HMV 180 E
	850	415	445	Tr 900x7	50	G 1/4	15	265	AOH 240/850 G	HM 31/900	HMV 180 E
	850	462	480	Tr 900x7	62	G 1/4	15	345	AOH 31/850	HM 31/900	HMV 180 E
	850	560	600	Tr 900x7	60	G 1/4	15	368	AOH 241/850	HM 31/900	HMV 180 E
	850	585	603	Tr 900x7	70	G 1/4	15	461	AOH 32/850	HM 31/900	HMV 180 E
850	900	335	355	Tr 950x8	55	G 1/4	15	250	AOH 30/900	HM 30/950	HMV 190 E
	900	430	475	Tr 950x8	55	G 1/4	15	296	AOH 240/900	HM 31/950	HMV 190 E
	900	475	495	Tr 950x8	63	G 1/4	15	379	AOH 31/900	HM 31/950	HMV 190 E
	900	575	620	Tr 950x8	60	G 1/4	15	402	AOH 241/900	HM 31/950	HMV 190 E
	900	585	605	Tr 950x8	70	G 1/4	15	489	AOH 32/900	HM 31/950	HMV 190 E
900	950	355	375	Tr 1000x8	55	G 1/4	15	285	AOH 30/950	HM 30/1000	HMV 200 E
	950	467	512	Tr 1000x8	55	G 1/4	15	340	AOH 240/950	HM 31/1000	HMV 200 E
	950	500	520	Tr 1000x8	62	G 1/4	15	426	AOH 31/950	HM 31/1000	HMV 200 E
	950	600	620	Tr 1000x8	70	G 1/4	15	533	AOH 32/950	HM 31/1000	HMV 200 E
	950	605	650	Tr 1000x8	60	G 1/4	15	449	AOH 241/950	HM 31/1000	HMV 200 E
950	1000	365	387	Tr 1060x8	57	G 1/4	15	318	AOH 30/1000	HM 30/1060	HMV 212 E
	1000	469	519	Tr 1060x8	57	G 1/4	15	369	AOH 240/1000	HM 31/1060	HMV 212 E
	1000	525	547	Tr 1060x8	63	G 1/4	15	485	AOH 31/1000	HM 31/1060	HMV 212 E
	1000	630	652	Tr 1060x8	70	G 1/4	15	608	AOH 32/1000	HM 31/1060	HMV 212 E
	1000	645	695	Tr 1060x8	65	G 1/4	15	519	AOH 241/1000	HM 31/1060	HMV 212 E
1000	1060	385	407	Tr 1120x8	60	G 1/4	15	406	AOH 30/1060	HM 30/1120	HMV 224 E
	1060	498	548	Tr 1120x8	60	G 1/4	15	479	AOH 240/1060	HM 30/1120	HMV 224 E
	1060	540	562	Tr 1120x8	65	G 1/4	15	599	AOH 31/1060	HM 30/1120	HMV 224 E
	1060	665	715	Tr 1120x8	65	G 1/4	15	652	AOH 241/1060	HM 30/1120	HMV 224 E

¹⁾ Width before the sleeve is driven into the bearing bore.
For bore diameter ≥ 1 060 mm, contact SKF.

16.5 KM(L) and HM .. T lock nuts

M 10x0,75 – M 200x3

Tr 210x4 – Tr 280x4

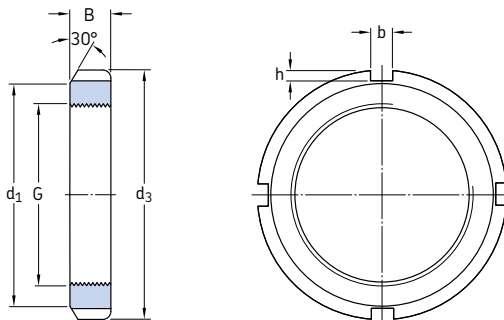

Dimensions						Axial load carrying capacity static	Mass	Designations		
G	d ₁	d ₃	B	b	h			Lock nut	Appropriate lock washer	spanner
mm						kN	kg	–		
M 10x0,75	13,5	18	4	3	2	9,8	0,004	KM 0	MB 0	HN 0
M 12x1	17	22	4	3	2	11,8	0,006	KM 1	MB 1	HN 1
M 15x1	21	25	5	4	2	14,6	0,009	KM 2	MB 2	HN 2-3
M 17x1	24	28	5	4	2	19,6	0,012	KM 3	MB 3	HN 2-3
M 20x1	26	32	6	4	2	24	0,025	KM 4	MB 4	HN 4
M 25x1,5	32	38	7	5	2	31,5	0,028	KM 5	MB 5	HN 5-6
M 30x1,5	38	45	7	5	2	36,5	0,039	KM 6	MB 6	HN 5-6
M 35x1,5	44	52	8	5	2	50	0,059	KM 7	MB 7	HN 7
M 40x1,5	50	58	9	6	2,5	62	0,078	KM 8	MB 8	HN 8-9
M 45x1,5	56	65	10	6	2,5	78	0,11	KM 9	MB 9	HN 8-9
M 50x1,5	61	70	11	6	2,5	91,5	0,14	KM 10	MB 10	HN 10-11
M 55x2	67	75	11	7	3	91,5	0,15	KM 11	MB 11	HN 10-11
M 60x2	73	80	11	7	3	95	0,16	KM 12	MB 12	HN 12-13
M 65x2	79	85	12	7	3	108	0,19	KM 13	MB 13	HN 12-13
M 70x2	85	92	12	8	3,5	118	0,23	KM 14	MB 14	HN 14
M 75x2	90	98	13	8	3,5	134	0,27	KM 15	MB 15	HN 15
M 80x2	95	105	15	8	3,5	173	0,36	KM 16	MB 16	HN 16
M 85x2	102	110	16	8	3,5	190	0,41	KM 17	MB 17	HN 17
M 90x2	108	120	16	10	4	216	0,51	KM 18	MB 18	HN 18-20
M 95x2	113	125	17	10	4	236	0,55	KM 19	MB 19	HN 18-20
M 100x2	120	130	18	10	4	255	0,64	KM 20	MB 20	HN 18-20

Dimensions						Axial load carrying capacity static	Mass	Designations		
G	d ₁	d ₃	B	b	h			Lock nut	Appropriate lock washer	spanner
mm						kN	kg	-		
M 105x2	126	140	18	12	5	290	0,79	KM 21	MB 21	HN 21-22
M 110x2	133	145	19	12	5	310	0,87	KM 22	MB 22	HN 21-22
M 115x2	137	150	19	12	5	315	0,91	KM 23	MB 23	TMFN 23-30
M 120x2	135	145	20	12	5	265	0,69	KML 24	MBL 24	HN 21-22
	138	155	20	12	5	340	0,97	KM 24	MB 24	TMFN 23-30
M 125x2	148	160	21	12	5	360	1,1	KM 25	MB 25	TMFN 23-30
M 130x2	145	155	21	12	5	285	0,8	KML 26	MBL 26	TMFN 23-30
	149	165	21	12	5	365	1,1	KM 26	MB 26	TMFN 23-30
M 135x2	160	175	22	14	6	430	1,4	KM 27	MB 27	TMFN 23-30
M 140x2	155	165	22	12	5	305	0,92	KML 28	MBL 28	TMFN 23-30
	160	180	22	14	6	430	1,4	KM 28	MB 28	TMFN 23-30
M 145x2	171	190	24	14	6	520	1,8	KM 29	MB 29	TMFN 23-30
M 150x2	170	180	24	14	5	390	1,25	KML 30	MBL 30	TMFN 23-30
	171	195	24	14	6	530	1,9	KM 30	MB 30	TMFN 23-30
M 155x3	182	200	25	16	7	540	2,1	KM 31	MB 31	TMFN 30-40
M 160x3	180	190	25	14	5	405	1,4	KML 32	MBL 32	TMFN 23-30
	182	210	25	16	7	585	2,3	KM 32	MB 32	TMFN 30-40
M 165x3	193	210	26	16	7	570	2,3	KM 33	MB 33	TMFN 30-40
M 170x3	190	200	26	16	5	430	1,55	KML 34	MBL 34	TMFN 30-40
	193	220	26	16	7	620	2,35	KM 34	MB 34	TMFN 30-40
M 180x3	200	210	27	16	5	450	1,8	KML 36	MBL 36	TMFN 30-40
	203	230	27	18	8	670	2,8	KM 36	MB 36	TMFN 30-40
M 190x3	210	220	28	16	5	475	1,85	KML 38	MBL 38	TMFN 30-40
	214	240	28	18	8	695	3,05	KM 38	MB 38	TMFN 30-40
M 200x3	222	240	29	18	8	625	2,6	KML 40	MBL 40	TMFN 30-40
	226	250	29	18	8	735	3,35	KM 40	MB 40	TMFN 30-40
Tr 210x4	238	270	30	20	10	- ¹⁾	5,1	HM 42 T	- ²⁾	TMFN 40-52
Tr 220x4	250	280	32	20	10	- ¹⁾	4,75	HM 44 T	MB 44	TMFN 40-52
Tr 230x4	260	290	34	20	10	- ¹⁾	5,45	HM 46 T	- ²⁾	TMFN 40-52
Tr 240x4	270	300	34	20	10	- ¹⁾	5,6	HM 48 T	MB 48	TMFN 40-52
Tr 250x4	290	320	36	20	10	- ¹⁾	7,45	HM 50 T	- ²⁾	TMFN 40-52
Tr 260x4	300	330	36	24	12	- ¹⁾	7,55	HM 52 T	MB 52	TMFN 52-64
Tr 280x4	320	350	38	24	12	- ¹⁾	8,65	HM 56 T	MB 56	TMFN 52-64

¹⁾ Contact SKF for information about axial load carrying capacity.

²⁾ HM .. T nuts having no appropriate lock washer are intended only for removal purposes.

16.6 MB(L) lock washers MB 0 – MB 56

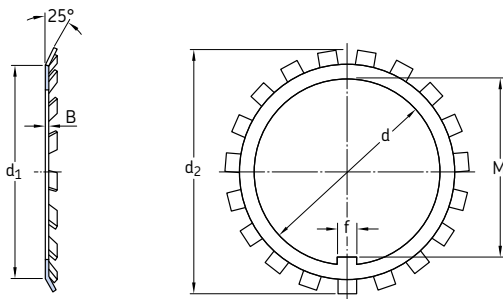

Designation	Dimensions						Mass	Designation	Dimensions						Mass
	d	d ₁	d ₂	B	f	M			d	d ₁	d ₂	B	f	M	
–	mm						kg	–	mm						kg
MB 0	10	13,5	21	1	3	8,5	0,001	MB 14	70	85	98	1,5	8	66,5	0,032
MB 1	12	17	25	1	3	10,5	0,002	MB 14 A	70	85	98	2,5	8	66,5	0,053
MB 1 A	12	17	25	1,2	3	10,5	0,0025	MB 15	75	90	104	1,5	8	71,5	0,035
MB 2	15	21	28	1	4	13,5	0,003	MB 15 A	75	90	104	2,5	8	71,5	0,058
MB 2 A	15	21	28	1,2	4	13,5	0,0035	MB 16	80	95	112	1,75	10	76,5	0,046
MB 3	17	24	32	1	4	15,5	0,003	MB 16 A	80	95	112	2,5	10	76,5	0,066
MB 3 A	17	24	32	1,2	4	15,5	0,0035	MB 17	85	102	119	1,75	10	81,5	0,053
MB 4	20	26	36	1	4	18,5	0,004	MB 17 A	85	102	119	2,5	10	81,5	0,076
MB 4 A	20	26	36	1,2	4	18,5	0,005	MB 18	90	108	126	1,75	10	86,5	0,061
MB 5	25	32	42	1,25	5	23	0,006	MB 18 A	90	108	126	2,5	10	86,5	0,087
MB 5 A	25	32	42	1,8	5	23	0,0085	MB 19	95	113	133	1,75	10	91,5	0,066
MB 6	30	38	49	1,25	5	27,5	0,008	MB 19 A	95	113	133	2,5	10	91,5	0,094
MB 6 A	30	38	49	1,8	5	27,5	0,011	MB 20	100	120	142	1,75	12	96,5	0,077
MB 7	35	44	57	1,25	6	32,5	0,011	MB 20 A	100	120	142	2,5	12	96,5	0,11
MB 7 A	35	44	57	1,8	6	32,5	0,016	MB 21	105	126	145	1,75	12	100,5	0,083
MB 8	40	50	62	1,25	6	37,5	0,013	MB 22	110	133	154	1,75	12	105,5	0,091
MB 8 A	40	50	62	1,8	6	37,5	0,018	MB 23	115	137	159	2	12	110,5	0,11
MB 9	45	56	69	1,25	6	42,5	0,015	MBL 24	120	135	152	2	14	115	0,07
MB 9 A	45	56	69	1,8	6	42,5	0,021	MB 24	120	138	164	2	14	115	0,11
MB 10	50	61	74	1,25	6	47,5	0,016	MB 25	125	148	170	2	14	120	0,12
MB 10 A	50	61	74	1,8	6	47,5	0,023	MBL 26	130	145	161	2	14	125	0,08
MB 11	55	67	81	1,5	8	52,5	0,022	MB 26	130	149	175	2	14	125	0,12
MB 11 A	55	67	81	2,5	8	52,5	0,037	MB 27	135	160	185	2	14	130	0,14
MB 12	60	73	86	1,5	8	57,5	0,024	MBL 28	140	155	172	2	16	135	0,09
MB 12 A	60	73	86	2,5	8	57,5	0,04	MB 28	140	160	192	2	16	135	0,14
MB 13	65	79	92	1,5	8	62,5	0,03								
MB 13 A	65	79	92	2,5	8	62,5	0,05								

Designation	Dimensions						Mass	
	d	d ₁	d ₂	B	f	M		
–	mm						kg	
MB 29	145	172	202	2	16	140	0,17	
MBL 30	150	170	189	2	16	145	0,1	
MB 30	150	171	205	2	16	145	0,18	
MB 31	155	182	212	2,5	16	147,5	0,2	
MBL 32	160	180	199	2,5	18	154	0,14	
MB 32	160	182	217	2,5	18	154	0,22	
MB 33	165	193	222	2,5	18	157,5	0,24	
MBL 34	170	190	211	2,5	18	164	0,15	
MB 34	170	193	232	2,5	18	164	0,24	
MBL 36	180	200	222	2,5	20	174	0,16	
MB 36	180	203	242	2,5	20	174	0,26	
MBL 38	190	210	232	2,5	20	184	0,17	
MB 38	190	214	252	2,5	20	184	0,26	
MBL 40	200	222	245	2,5	20	194	0,22	
MB 40	200	226	262	2,5	20	194	0,28	
MB 44	220	250	292	3	24	213	0,35	
MB 48	240	270	312	3	24	233	0,45	
MB 52	260	300	342	3	28	253	0,65	
MB 56	280	320	362	3	28	273	1,05	

16.7 HM(E) lock nuts Tr 220x4 – Tr 900x7

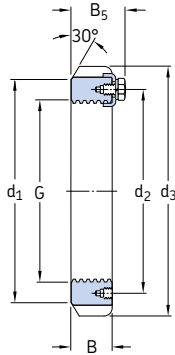

HM



HME

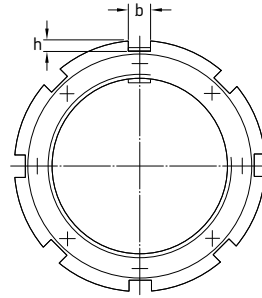

Dimensions				Mass		Designations Lock nut	Appropriate locking clip	spanner				
G	d ₁	d ₂	d ₃	B	B ₅				B ₃	b	h	
mm												
kg												
Tr 220x4	237	229	260	30	41	5	20	9	2,5	HME 3044	MS 3044	TMFN 40-52
	242	229	260	30	41	–	20	9	2,75	HM 3044	MS 3044	TMFN 40-52
Tr 240x4	264	253	290	34	46	8	20	10	4	HME 3048	MS 3052-48	TMFN 40-52
	270	253	290	34	46	–	20	10	4,5	HM 3048	MS 3052-48	TMFN 40-52
Tr 260x4	288	273	310	34	46	8	20	10	4,3	HME 3052	MS 3052-48	TMFN 40-52
	290	273	310	34	46	–	20	10	4,8	HM 3052	MS 3052-48	TMFN 40-52
Tr 280x4	310	293	330	38	50	–	24	10	5,75	HM 3056	MS 3056	TMFN 52-64
Tr 300x4	335	326	380	40	53	5	24	12	11	HME 3160	MS 3160	TMFN 52-64
	340	326	380	40	53	–	24	12	11,5	HM 3160	MS 3160	TMFN 52-64
	336	316	360	42	54	–	24	12	8,35	HM 3060	MS 3060	TMFN 52-64
Tr 320x5	356	336	380	42	55	–	24	12	9	HM 3064	MS 3068-64	TMFN 52-64
	360	346	400	42	56	–	24	12	13	HM 3164	MS 3164	TMFN 52-64
Tr 340x5	376	356	400	45	58	–	24	12	11	HM 3068	MS 3068-64	TMFN 52-64
	382	373	440	55	72	8	28	15	22	HME 3168	MS 3172-68	TMFN 64-80
	400	373	440	55	72	–	28	15	24	HM 3168	MS 3172-68	TMFN 64-80
Tr 360x5	394	375	420	45	58	8	28	13	11	HME 3072	MS 3072	TMFN 64-80
	394	375	420	45	58	–	28	13	11,5	HM 3072	MS 3072	TMFN 64-80
	406	393	460	58	75	10	28	15	24	HME 3172	MS 3172-68	TMFN 64-80
	420	393	460	58	75	–	28	15	26,5	HM 3172	MS 3172-68	TMFN 64-80
Tr 380x5	422	399	450	48	62	10	28	14	14	HME 3076	MS 3080-76	TMFN 64-80
	442	399	450	48	62	–	28	14	15	HM 3076	MS 3080-76	TMFN 64-80
	438	415	490	60	77	15	32	18	28,5	HME 3176	MS 3176	TMFN 64-80
	440	415	490	60	77	–	32	18	32	HM 3176	MS 3176	TMFN 64-80
Tr 400x5	442	419	470	52	66	10	28	14	16	HME 3080	MS 3080-76	TMFN 64-80
	442	419	470	52	66	–	28	14	17	HM 3080	MS 3080-76	TMFN 64-80
	456	440	520	62	82	15	32	18	33	HME 3180	MS 3184-80	TMFN 80-500
	460	440	520	62	82	–	32	18	38	HM 3180	MS 3184-80	TMFN 80-500
Tr 420x5	462	439	490	52	66	10	32	14	17	HME 3084	MS 3084	TMFN 64-80
	462	439	490	52	66	–	32	14	18,5	HM 3084	MS 3084	TMFN 64-80
	490	460	540	70	90	–	32	18	45	HM 3184	MS 3184-80	TMFN 80-500

Dimensions		Mass										Designations	Appropriate	spanner
G	d ₁	d ₂	d ₃	B	B ₅	B ₃	b	h			Lock nut	locking clip		
mm	kg										-			
Tr 440x5	488	463	520	60	77	12	32	15	24	HME 3088	MS 3092-88	TMFN 64-80		
	490	463	520	60	77	-	32	15	26	HM 3088	MS 3092-88	TMFN 64-80		
	508	478	560	70	90	15	36	20	42,5	HME 3188	MS 3192-88	TMFN 80-500		
	510	478	560	70	90	-	36	20	46,5	HM 3188	MS 3192-88	TMFN 80-500		
Tr 460x5	510	483	540	60	77	-	32	15	27	HM 3092	MS 3092-88	TMFN 80-500		
	535	498	580	75	95	20	36	20	45,5	HME 3192	MS 3192-88	TMFN 80-500		
	540	498	580	75	95	-	36	20	50,5	HM 3192	MS 3192-88	TMFN 80-500		
Tr 480x5	530	503	560	60	77	12	36	15	26	HME 3096	MS 30/500-96	TMFN 80-500		
	530	503	560	60	77	-	36	15	28	HM 3096	MS 30/500-96	TMFN 80-500		
	560	528	620	75	95	20	36	20	55	HME 3196	MS 3196	TMFN 80-500		
	560	528	620	75	95	-	36	20	62	HM 3196	MS 3196	TMFN 80-500		
Tr 500x5	550	523	580	68	85	12	36	15	31,5	HME 30/500	MS 30/500-96	TMFN 80-500		
	550	523	580	68	85	-	36	15	33,5	HM 30/500	MS 30/500-96	TMFN 500-600		
	580	540	630	80	100	12	40	23	60	HME 31/500	MS 31/500	TMFN 500-600		
	580	540	630	80	100	-	40	23	63,5	HM 31/500	MS 31/500	TMFN 500-600		
Tr 530x6	571	558	630	68	90	15	40	20	37	HME 30/530	MS 30/600-530	TMFN 500-600		
	590	558	630	68	90	-	40	20	42,5	HM 30/530	MS 30/600-530	TMFN 500-600		
	610	575	670	80	105	-	40	23	71,5	HM 31/530	MS 31/530	TMFN 500-600		
Tr 560x6	610	583	650	75	97	15	40	20	41	HME 30/560	MS 30/560	TMFN 500-600		
	610	583	650	75	97	-	40	20	44,5	HM 30/560	MS 30/560	TMFN 500-600		
	650	608	710	85	110	15	45	25	80,5	HME 31/560	MS 31/600-560	TMFN 500-600		
	650	608	710	85	110	-	45	25	86,5	HM 31/560	MS 31/600-560	TMFN 500-600		
Tr 600x6	657	628	700	75	97	18	40	20	47	HME 30/600	MS 30/600-530	TMFN 500-600		
	660	628	700	75	97	-	40	20	52,5	HM 30/600	MS 30/600-530	TMFN 500-600		
	690	648	750	85	110	15	45	25	85	HME 31/600	MS 31/600-560	TMFN 600-750		
	690	648	750	85	110	-	45	25	91,5	HM 31/600	MS 31/600-560	TMFN 600-750		
Tr 630x6	690	658	730	75	97	18	45	20	50	HME 30/630	MS 30/630	TMFN 500-600		
	690	658	730	75	97	-	45	20	55	HM 30/630	MS 30/630	TMFN 500-600		
	730	685	800	95	120	18	50	28	115	HME 31/630	MS 31/630	TMFN 600-750		
	730	685	800	95	120	-	50	28	125	HM 31/630	MS 31/630	TMFN 600-750		
Tr 670x6	740	703	780	80	102	-	45	20	68,5	HM 30/670	MS 30/670	TMFN 600-750		
	775	730	850	106	131	18	50	28	144	HME 31/670	MS 31/670	TMFN 600-750		
	775	730	850	106	131	-	50	28	155	HM 31/670	MS 31/670	TMFN 600-750		
Tr 710x7	766	742	830	90	112	20	50	25	81	HME 30/710	MS 30/710	TMFN 600-750		
	780	742	830	90	112	-	50	25	91,5	HM 30/710	MS 30/710	TMFN 600-750		
	825	772	900	106	133	20	55	30	149	HME 31/710	MS 31/710	TMFN 600-750		
	825	772	900	106	133	-	55	30	162	HM 31/710	MS 31/710	TMFN 600-750		
Tr 750x7	820	782	870	90	112	20	55	25	85,5	HME 30/750	MS 30/800-750	TMFN 600-750		
	820	782	870	90	112	-	55	25	94	HM 30/750	MS 30/800-750	TMFN 600-750		
	875	813	950	112	139	20	60	34	177	HME 31/750	MS 31/800-750	TMFN 600-750		
	875	813	950	112	139	-	60	34	190	HM 31/750	MS 31/800-750	TMFN 600-750		
Tr 800x7	870	832	920	90	112	20	55	25	90,5	HME 30/800	MS 30/800-750	TMFN 600-750		
	870	832	920	90	112	-	55	25	99,5	HM 30/800	MS 30/800-750	TMFN 600-750		
	925	863	1000	112	139	20	60	34	187	HME 31/800	MS 31/800-750	-		
	925	863	1000	112	139	-	60	34	202	HM 31/800	MS 31/800-750	-		
Tr 850x7	925	887	980	90	115	20	60	25	104	HME 30/850	MS 30/900-850	-		
	925	887	980	90	115	-	60	25	115	HM 30/850	MS 30/900-850	-		
	975	914	1060	118	145	25	70	38	212	HME 31/850	MS 31/850	-		
	975	914	1060	118	145	-	70	38	234	HM 31/850	MS 31/850	-		
Tr 900x7	975	937	1030	100	125	25	60	25	117	HME 30/900	MS 30/900-850	-		
	975	937	1030	100	125	-	60	25	131	HM 30/900	MS 30/900-850	-		
	1030	969	1120	125	154	-	70	38	280	HM 31/900	MS 31/900	-		

16.7 HM(E) lock nuts Tr 950x8 – Tr 1120x8

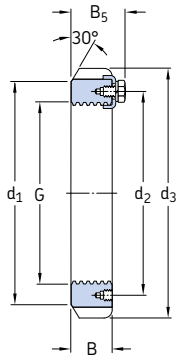

HM



HME

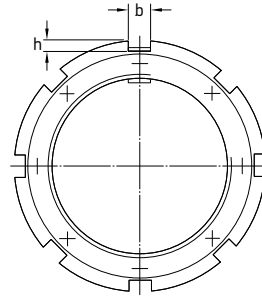

Dimensions										Mass	Designations Lock nut	Appropriate locking clip
G	d ₁	d ₂	d ₃	B	B ₅	B ₃	b	h				
mm										kg	-	
Tr 950x8	1 025	985	1 080	100	125	25	60	25	124	HME 30/950	MS 30/950	
	1 025	985	1 080	100	125	-	60	25	139	HM 30/950	MS 30/950	
	1 080	1 017	1 170	125	154	-	70	38	293	HM 31/950	MS 31/950	
Tr 1000x8	1 085	1 040	1 140	100	125	25	60	25	141	HME 30/1000	MS 30/1000	
	1 085	1 040	1 140	100	125	-	60	25	157	HM 30/1000	MS 30/1000	
	1 140	1 077	1 240	125	154	25	70	38	305	HME 31/1000	MS 31/1000	
	1 140	1 077	1 240	125	154	-	70	38	336	HM 31/1000	MS 31/1000	
Tr 1060x8	1 145	1 100	1 200	100	125	25	60	25	149	HME 30/1060	MS 30/1000	
	1 145	1 100	1 200	100	125	-	60	25	166	HM 30/1060	MS 30/1000	
	1 210	1 137	1 300	125	154	-	70	38	354	HM 31/1060	MS 31/1000	
Tr 1120x8	1 205	1 160	1 260	100	125	-	60	25	175	HM 30/1120	MS 30/1000	

16.8 MS locking clips

MS 3044 – MS 31/1000

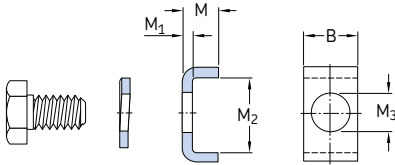

Designations Locking clip	Appertaining hexagonal head bolt	spring washer in accordance with DIN 128	Dimensions					Mass
			B	M	M ₁	M ₂	M ₃	
–			mm					kg
MS 3044	M 6x12	A 6	20	12	4	13,5	7	0,022
MS 3052-48	M 8x16	A 8	20	12	4	17,5	9	0,024
MS 3056	M 8x16	A 8	24	12	4	17,5	9	0,03
MS 3060	M 8x16	A 8	24	12	4	20,5	9	0,033
MS 3068-64	M 8x16	A 8	24	15	5	21	9	0,046
MS 3072	M 8x16	A 8	28	15	5	20	9	0,051
MS 3080-76	M 10x20	A 10	28	15	5	24	12	0,055
MS 3084	M 10x20	A 10	32	15	5	24	12	0,063
MS 3092-88	M 12x25	A 12	32	15	5	28	14	0,067
MS 30/500-96	M 12x25	A 12	36	15	5	28	14	0,076
MS 30/560	M 16x30	A 16	40	21	7	29	18	0,15
MS 30/600-530	M 16x30	A 16	40	21	7	34	18	0,14
MS 30/630	M 16x30	A 16	45	21	7	34	18	0,17
MS 30/670	M 16x30	A 16	45	21	7	39	18	0,19
MS 30/710	M 16x30	A 16	50	21	7	39	18	0,21
MS 30/800-750	M 16x30	A 16	55	21	7	39	18	0,23
MS 30/900-850	M 20x40	A 20	60	21	7	44	22	0,26
MS 30/950	M 20x40	A 20	60	21	7	46	22	0,26
MS 30/1000	M 20x40	A 20	60	21	7	51	22	0,28
MS 3160	M 10x20	A 10	24	12	4	30,5	12	0,04
MS 3164	M 10x20	A 10	24	15	5	31	12	0,055

Designations Locking clip	Appertaining hexagonal head bolt	spring washer in accordance with DIN 128	Dimensions					Mass
			B	M	M ₁	M ₂	M ₃	
–			mm					kg
MS 3172-68	M 12x25	A 12	28	15	5	38	14	0,069
MS 3176	M 12x25	A 12	32	15	5	40	14	0,083
MS 3184-80	M 16x30	A 16	32	15	5	45	18	0,089
MS 3192-88	M 16x30	A 16	36	15	5	43	18	0,097
MS 3196	M 16x30	A 16	36	15	5	53	18	0,11
MS 31/500	M 16x30	A 16	40	15	5	45	18	0,11
MS 31/530	M 20x40	A 20	40	21	7	51	22	0,19
MS 31/600-560	M 20x40	A 20	45	21	7	54	22	0,22
MS 31/630	M 20x40	A 20	50	21	7	61	22	0,27
MS 31/670	M 20x40	A 20	50	21	7	66	22	0,28
MS 31/710	M 24x50	A 24	55	21	7	69	26	0,32
MS 31/800-750	M 24x50	A 24	60	21	7	70	26	0,35
MS 31/850	M 24x50	A 24	70	21	7	71	26	0,41
MS 31/900	M 24x50	A 24	70	21	7	76	26	0,41
MS 31/950	M 24x50	A 24	70	21	7	78	26	0,42
MS 31/1000	M 24x50	A 24	70	21	7	88	26	0,5

16.9 N and AN inch lock nuts

G 0.391 – 10.192 in.

9,931 – 258,877 mm

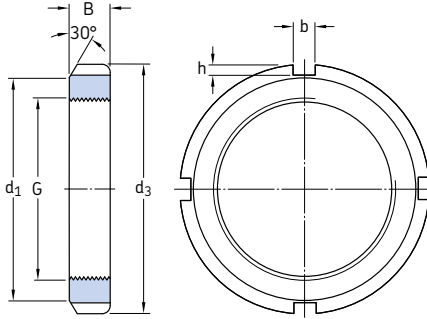

AN, N (size ≤ 44)

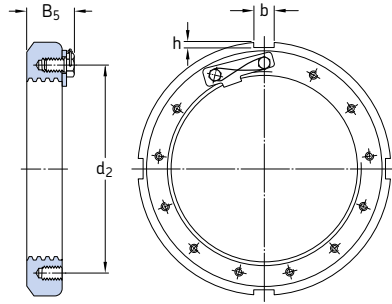

N (size ≥ 48)

Threads ¹⁾ G	Threads per inch	Dimensions					Mass	Designations		
		d ₁	d ₃	B	b	h		Lock nut	Appropriate locking spanner device	
in./mm	-	in.					kg	-		
0.391 9,931	32	0.625	³ / ₄	⁷ / ₃₂	0.12	0.073	0,0091	N 00	W 00	HN 0
0.469 11,913	32	0.719	⁷ / ₈	⁵ / ₁₆	0.12	0.073	0,018	N 01	W 01	HN 1
0.586 14,884	32	0.813	1	⁵ / ₁₆	0.12	0.104	0,023	N 02	W 02	HN 2-3
0.664 16,866	32	0.938	¹ / ₈	¹¹ / ₃₂	0.12	0.104	0,032	N 03	W 03	HN 2-3
0.781 19,837	32	1.125	¹ / ₈	³ / ₈	0.178	0.104	0,05	N 04	W 04	HN 4
0.969 24,613	32	1.281	¹ / ₁₆	¹³ / ₃₂	0.178	0.104	0,064	N 05	W 05	HN 5-6
1.173 29,794	18	1.5	¹ / ₄	¹³ / ₃₂	0.178	0.104	0,073	N 06	W 06	HN 5-6
1.376 34,95	18	1.813	² / ₁₆	⁷ / ₁₆	0.178	0.104	0,11	N 07	W 07	HN 7
1.563 39,7	18	2	² / ₄	⁷ / ₁₆	0.24	0.104	0,12	N 08	W 08	HN 8-9
1.767 44,882	18	2.281	² / ₃₂	⁷ / ₁₆	0.24	0.104	0,15	N 09	W 09	HN 8-9
1.967 49,962	18	2.438	² / ₁₆	¹ / ₂	0.24	0.104	0,18	N 10	W 10	HN 10-11
2.157 54,788	18	2.656	² / ₃₂	¹ / ₂	0.24	0.135	0,22	N 11	W 11	HN 10-11
2.36 59,944	18	2.844	³ / ₃₂	¹ / ₂	0.24	0.135	0,24	N 12	W 12	HN 12-13

¹⁾ For detailed information about threads, refer to ANSI/ABMA Standard 8.2.

Threads ¹⁾ G	Threads per inch	Dimensions							Mass kg	Designations		
		d ₁	d ₂	d ₃	B	B ₅	b	h		Lock nut	Appropriate locking device	spanner
in./mm	–	in.							kg	–		
2.548 64,719	18	3.063	–	3 ³ / ₈	9 ¹ / ₁₆	–	0.24	0.135	0,29	N 13	W 13	HN 12-13
2.751 69,875	18	3.313	–	3 ⁵ / ₈	9 ¹ / ₁₆	–	0.24	0.135	0,33	N 14	W 14	HN 14
2.933 74,498	12	3.563	–	3 ⁷ / ₈	1 ⁹ / ₃₂	–	0.36	0.135	0,41	AN 15	W 15	HN 15
3.137 79,68	12	3.844	–	4 ⁵ / ₃₂	1 ⁹ / ₃₂	–	0.36	0.135	0,48	AN 16	W 16	HN 16
3.34 84,836	12	4.031	–	4 ¹³ / ₃₂	5 ¹ / ₈	–	0.36	0.166	0,54	AN 17	W 17	HN 17
3.527 89,586	12	4.281	–	4 ²¹ / ₃₂	1 ¹¹ / ₁₆	–	0.36	0.166	0,68	AN 18	W 18	HN 18-20
3.73 94,742	12	4.563	–	4 ¹⁵ / ₁₆	2 ³ / ₃₂	–	0.36	0.166	0,79	AN 19	W 19	HN 18-20
3.918 99,517	12	4.813	–	5 ³ / ₁₆	3 ¹ / ₄	–	0.36	0.166	0,93	AN 20	W 20	HN 18-20
4.122 104,699	12	5	–	5 ⁷ / ₁₆	3 ¹ / ₄	–	0.485	0.198	1	AN 21	W 21	HN 21-22
4.325 109,855	12	4.901	–	5 ⁵ / ₁₆	2 ⁵ / ₃₂	–	0.485	0.198	0,79	N 022	W 022	HN 21-22
	12	5.281	–	5 ²³ / ₃₂	2 ⁵ / ₃₂	–	0.485	0.198	1,1	AN 22	W 22	HN 21-22
4.716 119,786	12	5.313	–	5 ¹¹ / ₁₆	1 ³ / ₁₆	–	0.485	0.198	0,86	N 024	W 024	TMFN 23-30
	12	5.688	–	6 ¹ / ₈	1 ³ / ₁₆	–	0.485	0.198	1,25	AN 24	W 24	TMFN 23-30
5.106 129,692	12	5.703	–	6 ¹ / ₈	7 ¹ / ₈	–	0.485	0.198	1,2	N 026	W 026	TMFN 23-30
	12	6.188	–	6 ³ / ₄	7 ¹ / ₈	–	0.61	0.26	1,75	AN 26	W 26	TMFN 23-30
5.497 139,624	12	6.109	–	6 ¹ / ₂	1 ⁵ / ₁₆	–	0.485	0.198	1,2	N 028	W 028	TMFN 23-30
	12	6.531	–	7 ³ / ₃₂	1 ⁵ / ₁₆	–	0.61	0.26	1,95	AN 28	W 28	TMFN 23-30
5.888 149,555	12	6.688	–	7 ¹ / ₈	3 ¹ / ₃₂	–	0.61	0.229	1,65	N 030	W 030	TMFN 23-30
	12	7.063	–	7 ¹¹ / ₁₆	3 ¹ / ₃₂	–	0.61	0.291	2,45	AN 30	W 30	TMFN 23-30
6.284 159,614	8	7.094	–	7 ¹ / ₂	1 ¹ / ₃₂	–	0.61	0.229	1,9	N 032	W 032	TMFN 23-30
	8	7.438	–	8 ¹ / ₁₆	1 ¹ / ₃₂	–	0.61	0.291	2,8	AN 32	W 32	TMFN 30-40
6.659 169,139	8	7.484	–	7 ⁷ / ₈	1 ¹ / ₁₆	–	0.61	0.229	2,05	N 034	W 034	TMFN 30-40
	8	8.031	–	8 ²¹ / ₃₂	1 ¹ / ₁₆	–	0.61	0.291	3,4	AN 34	W 34	TMFN 30-40
7.066 179,476	8	7.875	–	8 ¹ / ₄	1 ³ / ₃₂	–	0.61	0.229	2,2	N 036	W 036	TMFN 30-40
	8	8.375	–	9 ¹ / ₁₆	1 ³ / ₃₂	–	0.735	0.323	3,75	AN 36	W 36	TMFN 30-40
7.472 189,789	8	8.266	–	8 ¹¹ / ₁₆	1 ¹ / ₈	–	0.61	0.229	3	N 038	W 038	TMFN 30-40
	8	8.781	–	9 ¹⁵ / ₃₂	1 ¹ / ₈	–	0.735	0.323	4	AN 38	W 38	TMFN 30-40
7.847 199,314	8	8.75	–	9 ⁷ / ₁₆	1 ³ / ₁₆	–	0.735	0.323	3,45	N 040	W 040	TMFN 30-40
	8	9.156	–	9 ²⁷ / ₃₂	1 ³ / ₁₆	–	0.735	0.323	4,4	AN 40	W 40	TMFN 30-40
8.628 219,151	8	9.531	–	10 ¹ / ₄	1 ¹ / ₄	–	0.86	0.385	4,2	N 044	W 044	TMFN 40-52
	8	9.843	–	11	1 ¹ / ₄	–	0.98	0.51	6,1	N 44	W 44	TMFN 40-52
9.442 239,827	6	10.625	10,423	11 ⁷ / ₁₆	1 ¹¹ / ₃₂	1,698	0.86	0.385	5,9	N 048	PL 48	TMFN 40-52
10.192 258,877	6	11.406	11,298	12 ³ / ₁₆	1 ¹¹ / ₃₂	1,76	0.86	0.385	6,8	N 052	PL 52	TMFN 40-52

¹⁾ For detailed information about threads, refer to ANSI/ABMA Standard 8.2.

16.9 N and AN inch lock nuts

G 11.004 – 20.867 in.

279,502 – 530,022 mm

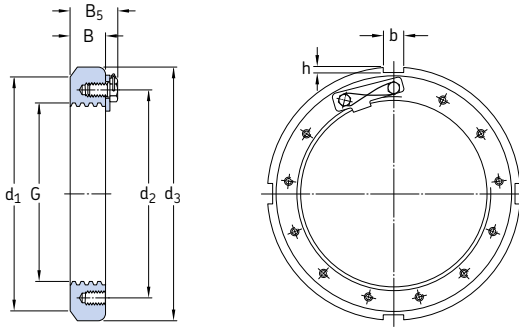

Threads ¹⁾ G	Threads per inch	Dimensions							Mass	Designations		
		d ₁	d ₂	d ₃	B	B ₅	b	h		Lock nut	Appropriate locking spanner device	
in./mm	-	in.							kg	-		
11.004 279,502	6	12.219	12,11	13	1 1/2	1,854	0,98	0,385	7,7	N 056	PL 56	TMFN 52-64
11.785 299,339	6	13.219	13,11	14 3/16	1 9/16	1,948	0,98	0,51	10,5	N 060	PL 60	TMFN 52-64
12.562 319,075	6	14.031	13,86	15	1 21/32	2,041	0,98	0,51	12	N 064	PL 64	TMFN 52-64
13.339 338,811	5	14.813	14,735	15 3/4	1 25/32	2,166	0,98	0,51	13,5	N 068	PL 68	TMFN 52-64
14.17 359,918	5	15.5	15,485	16 1/2	1 25/32	2,166	1,23	0,51	13,5	N 072	PL 72	TMFN 64-80
14.957 379,908	5	16.625	16,485	17 3/4	1 29/32	2,353	1,23	0,604	18,5	N 076	PL 76	TMFN 64-80
15.745 399,923	5	17.438	17,235	18 1/2	2 1/16	2,5	1,23	0,604	21	N 080	PL 80	TMFN 64-80
16.532 419,913	5	18.188	18,11	19 5/16	2 1/16	2,5	1,355	0,604	22	N 084	PL 84	TMFN 64-80
17.319 439,903	5	19.25	19,11	20 1/2	2 3/8	2,906	1,355	0,604	30	N 088	PL 88	TMFN 64-80
18.107 459,918	5	20.688	19,985	21 1/4	2 3/8	2,906	1,355	0,604	31	N 092	PL 92	TMFN 80-500
18.894 479,908	5	20.75	20,673	22 1/16	2 3/8	2,937	1,48	0,604	32,5	N 096	PL 96	TMFN 80-500
19.682 499,923	5	21.688	21,61	22 13/16	2 11/16	3,25	1,48	0,604	36	N 500	PL 500	TMFN 80-500
20.867 530,022	4	23.25	23,36	24 13/16	2 11/16	3,25	1,605	0,823	48,5	N 530	PL 530	TMFN 80-500

¹⁾ For detailed information about threads, refer to ANSI/ABMA Standard 8.2.

16.10 W inch lock washers W 00 – W 44

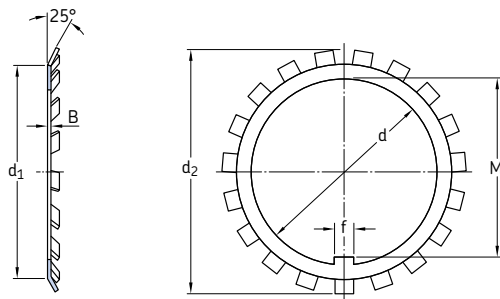

Designation	Dimensions						Mass
	d	d ₁	d ₂	B	f	M	
–	in.						kg
W 00	0.406	0.655	0.875	0.032	0.12	0.334	0,094
W 01	0.484	0.749	1.016	0.032	0.12	0.412	0,1
W 02	0.601	0.843	1.156	0.032	0.12	0.529	0,13
W 03	0.679	0.968	1.328	0.032	0.12	0.607	0,24
W 04	0.801	1.155	1.531	0.032	0.176	0.729	0,002
W 05	0.989	1.311	1.719	0.04	0.176	0.909	0,007
W 06	1.193	1.53	1.922	0.04	0.176	1.093	0,008
W 07	1.396	1.843	2.25	0.04	0.176	1.296	0,008
W 08	1.583	2.03	2.469	0.048	0.29	1.478	0,014
W 09	1.792	2.311	2.734	0.048	0.29	1.687	0,019
W 10	1.992	2.468	2.922	0.048	0.29	1.887	0,021
W 11	2.182	2.686	3.109	0.053	0.29	2.069	0,02
W 12	2.4	2.874	3.344	0.053	0.29	2.267	0,022
W 13	2.588	3.093	3.578	0.053	0.29	2.455	0,025
W 14	2.791	3.343	3.828	0.053	0.29	2.658	0,027
W 15	2.973	3.593	4.109	0.062	0.29	2.834	0,032
W 16	3.177	3.874	4.375	0.062	0.353	3.038	0,048
W 17	3.395	4.061	4.625	0.062	0.353	3.253	0,053
W 18	3.582	4.311	4.938	0.084	0.353	3.418	0,057
W 19	3.8	4.593	5.219	0.084	0.353	3.636	0,07
W 20	3.988	4.843	5.5	0.084	0.353	3.809	0,082

Designation	Dimensions						Mass
	d	d ₁	d ₂	B	f	M	
–	in.						kg
W 21	4.192	5.03	5.703	0.084	0.353	4.013	0,094
W 022	4.395	4.951	5.688	0.115	0.35	4.185	0,15
W 22	4.395	5.311	6.063	0.115	0.353	4.185	0,1
W 024	4.801	5.363	6.188	0.115	0.35	4.591	0,19
W 24	4.801	5.718	6.469	0.115	0.353	4.591	0,16
W 026	5.191	5.753	6.625	0.115	0.469	4.969	0,2
W 26	5.191	6.218	7.031	0.115	0.435	4.969	0,17
W 028	5.582	6.159	7.094	0.115	0.594	5.36	0,23
W 28	5.582	6.561	7.438	0.115	0.59	5.36	0,22
W 030	5.983	6.738	7.719	0.115	0.594	5.73	0,25
W 30	5.983	7.093	8.063	0.146	0.59	5.73	0,22
W 032	6.389	7.144	8.156	0.115	0.594	6.128	0,29
W 32	6.389	7.468	8.438	0.146	0.59	6.128	0,33
W 034	6.764	7.538	8.594	0.115	0.719	6.503	0,3
W 34	6.764	8.061	9.063	0.146	0.715	6.503	0,34
W 036	7.171	7.929	9	0.115	0.719	6.91	0,6
W 36	7.171	8.405	9.438	0.146	0.715	6.91	0,42
W 038	7.577	8.32	9.438	0.115	0.719	7.316	0,002
W 38	7.577	8.811	9.875	0.146	0.715	7.316	0,43
W 040	7.982	8.804	9.969	0.115	0.844	7.721	0,003
W 40	7.982	9.186	10.313	0.146	0.84	7.721	0,46
W 044	8.701	9.6	10.406	0.115	0.945	8.327	0,005
W 44	8.701	9.905	11.438	0.146	0.94	8.327	0,47

16.11 PL inch locking plates PL 48 – 530

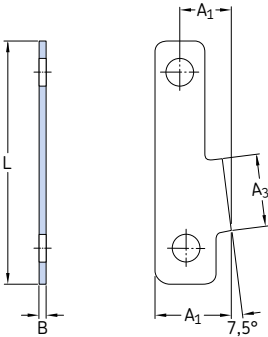

Designations Locking plate	Appertaining hexagonal head bolt	Dimensions					Mass
		A ₁	A ₂	A ₃	B	L	
–		in.					kg
PL 48	5/16–18x5/8	1.125	0.813	1	0.126	3.5	0,06
PL 52	5/16–18x5/8	1.156	0.804	1.063	0.126	3.75	0,07
PL 56	5/16–18x5/8	1.156	0.822	1.125	0.126	3.938	0,07
PL 60	3/8–16x3/4	1.375	0.915	1.25	0.126	4.344	0,1
PL 64	3/8–16x3/4	1.312	0.888	1.313	0.126	4.531	0,1
PL 68	3/8–16x3/4	1.25	0.856	1.375	0.126	4.75	0,1
PL 72	3/8–16x3/4	1.25	0.856	1.375	0.126	4.906	0,1
PL 76	1/2–13x7/8	1.5	1.039	1.375	0.126	5.438	0,2
PL 80	1/2–13x7/8	1.469	0.976	1.5	0.126	5.719	0,2
PL 84	1/2–13x7/8	1.562	1.067	1.5	0.126	5.812	0,2
PL 88	5/8–11x1	1.656	1.125	1.688	0.126	6.25	0,27
PL 92	5/8–11x1	1.656	1.063	1.688	0.126	6.422	0,28
PL 96	5/8–11x1 1/4	1.562	0.999	1.688	0.157	6.594	0,33
PL 500	5/8–11x1 1/4	1.688	1.125	1.688	0.157	6.844	0,33
PL 530	5/8–11x1 1/4	2.125	1.562	1.688	0.157	7.312	0,4

Two hexagonal head bolts and a wire to secure the bolts are supplied with a locking plate.

16.12 KMK lock nuts with an integral locking device M 10x0,75 – M 100x2

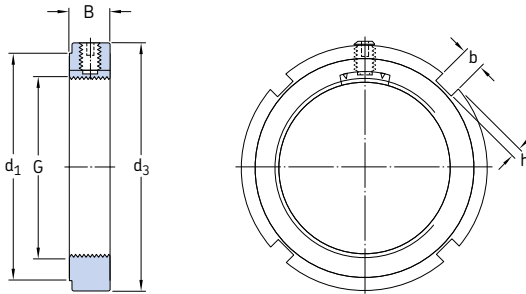

Dimensions		Axial load carrying capacity static		Mass	Designations		Grub screw				
G	d ₁	d ₃	B	b	h	Lock nut	Appropriate spanner	Size	Recommended tightening torque		
mm						kN	kg	-	Nm		
M 10x0,75	16	20	9	3	2	9,8	0,016	KMK 0	HN 0	M 5	4
M 12x1	18	22	9	3	2	11,8	0,018	KMK 1	HN 1	M 5	4
M 15x1	21	25	9	4	2	14,6	0,021	KMK 2	HN 2-3	M 5	4
M 17x1	24	28	9	4	2	19,6	0,027	KMK 3	HN 2-3	M 5	4
M 20x1	28	32	9	4	2	24	0,03	KMK 4	HN 4	M 5	4
M 25x1,5	34	38	9	5	2	31,5	0,03	KMK 5	HN 5-6	M 5	4
M 30x1,5	41	45	9	5	2	36,5	0,06	KMK 6	HN 5-6	M 5	4
M 35x1,5	48	52	9	5	2	50	0,07	KMK 7	HN 7	M 5	4
M 40x1,5	53	58	11	6	2,5	62	0,11	KMK 8	HN 8-9	M 6	8
M 45x1,5	60	65	11	6	2,5	78	0,14	KMK 9	HN 8-9	M 6	8
M 50x1,5	65	70	15	6	2,5	91,5	0,2	KMK 10	HN 10-11	M 8	18
M 55x2	69	75	15	7	3	91,5	0,22	KMK 11	HN 10-11	M 8	18
M 60x2	74	80	15	7	3	95	0,23	KMK 12	HN 12-13	M 8	18
M 65x2	79	85	14	7	3	108	0,24	KMK 13	HN 12-13	M 8	18
M 70x2	85	92	14	8	3,5	118	0,28	KMK 14	HN 14	M 8	18
M 75x2	91	98	14	8	3,5	134	0,33	KMK 15	HN 15	M 8	18
M 80x2	98	105	18	8	3,5	173	0,45	KMK 16	HN 16	M 10	35
M 85x2	103	110	18	8	3,5	190	0,52	KMK 17	HN 17	M 10	35
M 90x2	112	120	18	10	4	216	0,65	KMK 18	HN 18-20	M 10	35
M 95x2	117	125	20	10	4	236	0,76	KMK 19	HN 18-20	M 10	35
M 100x2	122	130	20	10	4	255	0,8	KMK 20	HN 18-20	M 10	35

16.13 KMFE lock nuts with a locking screw M 20x1 – M 200x3

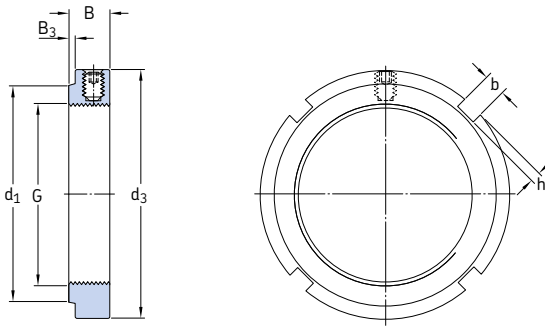

Dimensions		Axial load carrying capacity static		Mass	Designations	Appropriate spanner	Grub screw Size	Recommended tightening torque				
G	d ₁	d ₃	B	B ₃	b	h						
mm								Nm				
M 20x1	26	32	9,5	1	4	2	24	0,031	KMFE 4	HN 4	M 5	4
M 25x1,5	30	38	10,5	2	5	2	31,5	0,041	KMFE 5 L	HN 5-6	M 5	4
	31	38	10,5	2	5	2	31,5	0,042	KMFE 5	HN 5-6	M 5	4
M 30x1,5	36	45	10,5	2	5	2	36,5	0,058	KMFE 6	HN 5-6	M 5	4
M 35x1,5	41,5	52	11,5	3	5	2	50	0,079	KMFE 7 L	HN 7	M 5	4
	42,5	52	11,5	3	5	2	50	0,08	KMFE 7	HN 7	M 5	4
M 40x1,5	47	58	13	3	6	2,5	52	0,11	KMFE 8	HN 8-9	M 6	8
	47,5	58	13	3	6	2,5	52	0,12	KMFE 8 H	HN 8-9	M 6	8
M 45x1,5	53	65	13	3	6	2,5	78	0,14	KMFE 9	HN 8-9	M 6	8
	54,5	65	13	3	6	2,5	78	0,15	KMFE 9 H	HN 8-9	M 6	8
M 50x1,5	57,5	70	14	3	6	2,5	91,5	0,16	KMFE 10	HN 10-11	M 6	8
	61,5	70	14	3	6	2,5	91,5	0,17	KMFE 10 H	HN 10-11	M 6	8
M 55x2	64	75	14	3	7	3	91,5	0,18	KMFE 11	HN 10-11	M 6	8
	67	75	14	3	7	3	91,5	0,19	KMFE 11 H	HN 10-11	M 6	8
M 60x2	69	80	14	3	7	3	95	0,19	KMFE 12	HN 12-13	M 6	8
M 65x2	71,5	85	15	3	7	3	108	0,22	KMFE 13 L	HN 12-13	M 6	8
	76	85	15	3	7	3	108	0,23	KMFE 13	HN 12-13	M 6	8
	77,5	85	15	3	7	3	108	0,24	KMFE 13 H	HN 12-13	M 6	8
M 70x2	79	92	15	3	8	3,5	118	0,26	KMFE 14	HN 14	M 6	8
M 75x2	81,5	98	16	3	8	3,5	134	0,31	KMFE 15 L	HN 15	M 6	8
	85	98	16	3	8	3,5	134	0,32	KMFE 15	HN 15	M 6	8
	87,5	98	16	3	8	3,5	134	0,33	KMFE 15 H	HN 15	M 6	8
M 80x2	91,5	105	18	3	8	3,5	173	0,42	KMFE 16	HN 16	M 8	18
	93	105	18	3	8	3,5	173	0,43	KMFE 16 H	HN 16	M 8	18
M 85x2	98	110	19	4	8	3,5	190	0,46	KMFE 17	HN 17	M 8	18
M 90x2	102	120	19	4	10	4	216	0,58	KMFE 18	HN 18-20	M 8	18

Dimensions								Axial load carrying capacity static	Mass	Designations		Grub screw	
G	d ₁	d ₃	B	B ₃	b	h	Lock nut			Appropriate spanner	Size	Recommended tightening torque	
mm								kN	kg	–		–	Nm
M 95x2	108	125	20	4	10	4	236	0,65	KMFE 19 L	HN 18-20	M 8	18	
	110	125	20	4	10	4	236	0,66	KMFE 19	HN 18-20	M 8	18	
M 100x2	110	130	21	4	10	4	255	0,7	KMFE 20 L	HN 18-20	M 8	18	
	112	130	21	4	10	4	255	0,71	KMFE 20	HN 18-20	M 8	18	
M 110x2	119	145	21,5	4	12	5	310	0,92	KMFE 22 L	HN 21-22	M 8	18	
	122	145	21,5	4	12	5	310	0,93	KMFE 22	HN 21-22	M 8	18	
	124	145	21,5	4	12	5	310	0,94	KMFE 22 H	HN 21-22	M 8	18	
M 120x2	130	155	26	6	12	5	340	1,15	KMFE 24	TMFN 23-30	M 10	35	
	132	155	26	6	12	5	340	1,15	KMFE 24 H	TMFN 23-30	M 10	35	
M 130x2	140	165	28	7	12	5	365	1,3	KMFE 26 L	TMFN 23-30	M 10	35	
	141	165	28	7	12	5	365	1,35	KMFE 26	TMFN 23-30	M 10	35	
M 140x2	151	180	28	7	14	6	420	1,55	KMFE 28 L	TMFN 23-30	M 10	35	
	152	180	28	7	14	6	440	1,55	KMFE 28	TMFN 23-30	M 10	35	
M 150x2	162	195	30	9	14	6	495	2,05	KMFE 30	TMFN 23-30	M 10	35	
M 160x3	173	210	32	11	16	7	540	2,5	KMFE 32	TMFN 30-40	M 10	35	
M 170x3	184	220	33	12	16	7	550	2,7	KMFE 34	TMFN 30-40	M 10	35	
M 180x3	194	230	34	12	18	8	590	3	KMFE 36	TMFN 30-40	M 10	35	
M 190x3	207	240	34	12	18	8	610	3,1	KMFE 38	TMFN 30-40	M 10	35	
M 200x3	217	250	34	12	18	8	625	3,3	KMFE 40	TMFN 30-40	M 10	35	

16.14 KMT precision lock nuts with locking pins M 10x0,75 – M 200x3

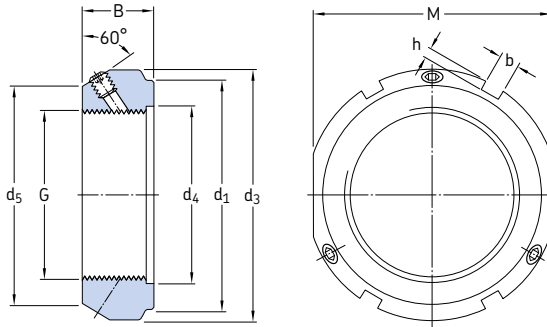

Dimensions										Axial load carrying capacity static	Mass	Designations		Grub screw	
G	d ₁	d ₃	d ₄	d ₅	B	b	h	M	Lock nut			Appropriate spanner	Size	Recommended tightening torque	
mm										kN	kg	-		-	Nm
M 10x0,75	23	28	11	21	14	4	2	24	35	0,045	KMT 0	HN 2-3	M 5	4,5	
M 12x1	25	30	13	23	14	4	2	27	40	0,05	KMT 1	HN 4	M 5	4,5	
M 15x1	28	33	16	26	16	4	2	30	60	0,075	KMT 2	HN 4	M 5	4,5	
M 17x1	33	37	18	29	18	5	2	34	80	0,1	KMT 3	HN 5-6	M 6	8	
M 20x1	35	40	21	32	18	5	2	36	90	0,11	KMT 4	HN 5-6	M 6	8	
M 25x1,5	39	44	26	36	20	5	2	41	130	0,13	KMT 5	HN 5-6	M 6	8	
M 30x1,5	44	49	32	41	20	5	2	46	160	0,16	KMT 6	HN 7	M 6	8	
M 35x1,5	49	54	38	46	22	5	2	50	190	0,19	KMT 7	HN 7	M 6	8	
M 40x1,5	59	65	42	54	22	6	2,5	60	210	0,3	KMT 8	HN 8-9	M 8	18	
M 45x1,5	64	70	48	60	22	6	2,5	65	240	0,33	KMT 9	HN 10-11	M 8	18	
M 50x1,5	68	75	52	64	25	7	3	70	300	0,4	KMT 10	HN 10-11	M 8	18	
M 55x2	78	85	58	74	25	7	3	80	340	0,54	KMT 11	HN 12-13	M 8	18	
M 60x2	82	90	62	78	26	8	3,5	85	380	0,61	KMT 12	HN 12-13	M 8	18	
M 65x2	87	95	68	83	28	8	3,5	90	460	0,71	KMT 13	HN 15	M 8	18	
M 70x2	92	100	72	88	28	8	3,5	95	490	0,75	KMT 14	HN 15	M 8	18	
M 75x2	97	105	77	93	28	8	3,5	100	520	0,8	KMT 15	HN 16	M 8	18	
M 80x2	100	110	83	98	32	8	3,5	-	620	0,9	KMT 16	HN 17	M 8	18	
M 85x2	110	120	88	107	32	10	4	-	650	1,15	KMT 17	HN 18-20	M 10	35	
M 90x2	115	125	93	112	32	10	4	-	680	1,2	KMT 18	HN 18-20	M 10	35	
M 95x2	120	130	98	117	32	10	4	-	710	1,25	KMT 19	HN 18-20	M 10	35	
M 100x2	125	135	103	122	32	10	4	-	740	1,3	KMT 20	HN 21-22	M 10	35	

Dimensions								Axial load carrying capacity static	Mass	Designations		Grub screw	
G	d ₁	d ₃	d ₄	d ₅	B	b	h			Lock nut	Appropriate spanner	Size	Recommended tightening torque
mm								kN	kg	–	–	Nm	
M 110x2	134	145	112	132	32	10	4	800	1,45	KMT 22	HN 21-22	M10	35
M 120x2	144	155	122	142	32	10	4	860	1,6	KMT 24	HN 21-22	M10	35
M 130x2	154	165	132	152	32	12	5	920	1,7	KMT 26	TMFN 23-30	M10	35
M 140x2	164	175	142	162	32	14	5	980	1,8	KMT 28	TMFN 23-30	M10	35
M 150x2	174	185	152	172	32	14	5	1040	1,95	KMT 30	TMFN 23-30	M10	35
M 160x3	184	195	162	182	32	14	5	1100	2,1	KMT 32	TMFN 23-30	M10	35
M 170x3	192	205	172	192	32	14	5	1160	2,2	KMT 34	TMFN 30-40	M10	35
M 180x3	204	215	182	202	32	16	5	1220	2,3	KMT 36	TMFN 30-40	M10	35
M 190x3	214	225	192	212	32	16	5	1280	2,4	KMT 38	TMFN 30-40	M10	35
M 200x3	224	235	202	222	32	18	5	1340	2,5	KMT 40	TMFN 30-40	M10	35

16.15 KMTA precision lock nuts with locking pins M 25x1,5 – M 200x3

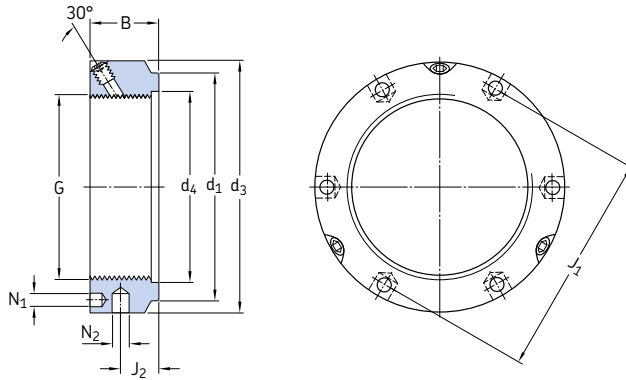

Dimensions		Axial load carrying capacity		Mass	Designations		Grub screw								
G	d ₁	d ₃	d ₄		B	J ₁	J ₂	N ₁	N ₂	static	kg	Lock nut	Appropriate spanner	Size	Recommended tightening torque
mm										kN	kg	–	–	–	Nm
M 25x1,5	35	42	26	20	32,5	11	4,3	4	130	0,13	KMTA 5	B 40-42	M 6	8	
M 30x1,5	40	48	32	20	40,5	11	4,3	5	160	0,16	KMTA 6	B 45-50	M 6	8	
M 35x1,5	47	53	38	20	45,5	11	4,3	5	190	0,19	KMTA 7	B 52-55	M 6	8	
M 40x1,5	52	58	42	22	50,5	12	4,3	5	210	0,23	KMTA 8	B 58-62	M 6	8	
M 45x1,5	58	68	48	22	58	12	4,3	6	240	0,33	KMTA 9	B 68-75	M 6	8	
M 50x1,5	63	70	52	24	61,5	13	4,3	6	300	0,34	KMTA 10	B 68-75	M 6	8	
M 55x1,5	70	75	58	24	66,5	13	4,3	6	340	0,37	KMTA 11	B 68-75	M 6	8	
M 60x1,5	75	84	62	24	74,5	13	5,3	6	380	0,49	KMTA 12	B 80-90	M 8	18	
M 65x1,5	80	88	68	25	78,5	13	5,3	6	460	0,52	KMTA 13	B 80-90	M 8	18	
M 70x1,5	86	95	72	26	85	14	5,3	8	490	0,62	KMTA 14	B 95-100	M 8	18	
M 75x1,5	91	100	77	26	88	13	6,4	8	520	0,66	KMTA 15	B 95-100	M 8	18	
M 80x2	97	110	83	30	95	16	6,4	8	620	1	KMTA 16	B 110-115	M 8	18	
M 85x2	102	115	88	32	100	17	6,4	8	650	1,15	KMTA 17	B 110-115	M 10	35	
M 90x2	110	120	93	32	108	17	6,4	8	680	1,2	KMTA 18	B 120-130	M 10	35	
M 95x2	114	125	98	32	113	17	6,4	8	710	1,25	KMTA 19	B 120-130	M 10	35	
M 100x2	120	130	103	32	118	17	6,4	8	740	1,3	KMTA 20	B 120-130	M 10	35	
M 110x2	132	140	112	32	128	17	6,4	8	800	1,45	KMTA 22	B 135-145	M 10	35	
M 120x2	142	155	122	32	140	17	6,4	8	860	1,85	KMTA 24	B 155-165	M 10	35	
M 130x3	156	165	132	32	153	17	6,4	8	920	2	KMTA 26	B 155-165	M 10	35	
M 140x3	166	180	142	32	165	17	6,4	10	980	2,45	KMTA 28	B 180-195	M 10	35	
M 150x3	180	190	152	32	175	17	6,4	10	1 040	2,6	KMTA 30	B 180-195	M 10	35	

Dimensions										Axial load carrying capacity static	Mass	Designations		Grub screw	
G	d ₁	d ₃	d ₄	B	J ₁	J ₂	N ₁	N ₂	Lock nut			Appropriate spanner	Size	Recommended tightening torque	
mm									kN	kg	–	–	Nm		
M 160x3	190	205	162	32	185	17	8,4	10	1 100	3,15	KMTA 32	B 205-220	M 10	35	
M 170x3	205	215	172	32	195	17	8,4	10	1 160	3,3	KMTA 34	B 205-220	M 10	35	
M 180x3	215	230	182	32	210	17	8,4	10	1 220	3,9	KMTA 36	B 230-245	M 10	35	
M 190x3	225	240	192	32	224	17	8,4	10	1 280	4,1	KMTA 38	B 230-245	M 10	35	
M 200x3	237	245	202	32	229	17	8,4	10	1 340	3,85	KMTA 40	B 230-245	M 10	35	

16.16 KMD precision lock nuts with axial locking screws M 20x1 – M 105x2

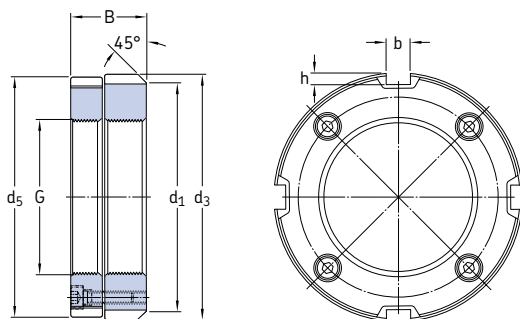

Dimensions		Axial load carrying capacity static		Mass	Designation	Locking screws					
G	d ₁	d ₃	d ₅	B	b	h	Size	Recommended tightening torque			
mm								Nm			
M 20x1	38	40	39	18	5	2	70	0,11	KMD 4	M 4	4,2
M 25x1,5	43	45	44	20	5	2	95	0,14	KMD 5	M 4	4,2
M 30x1,5	48	50	49	20	5	2	105	0,2	KMD 6	M 4	4,2
M 35x1,5	53	58	57	22	6	2,5	120	0,24	KMD 7	M 4	4,2
M 40x1,5	58	63	62	22	6	2,5	130	0,27	KMD 8	M 4	4,2
M 45x1,5	66,5	71,5	70,5	22	7	3	150	0,36	KMD 9	M 4	4,2
M 50x1,5	70	75	74	25	7	3	200	0,41	KMD 10	M 4	4,2
M 55x2	75	80	79	25	7	3	160	0,46	KMD 11 P	M 4	4,2
M 60x2	80	85	84	26	7	3	175	0,5	KMD 12 P	M 4	4,2
M 65x2	85	90	89	28	8	3,5	295	0,63	KMD 13	M 5	8,4
M 70x2	90	95	94	28	8	3,5	320	0,67	KMD 14	M 5	8,4
M 75x2	95	100	99	28	8	3,5	340	0,72	KMD 15	M 5	8,4
M 80x2	105	110	109	32	8	3,5	445	1,05	KMD 16	M 6	14,2
M 85x2	110	115	114	32	10	4	470	1,2	KMD 17	M 6	14,2
M 90x2	115	120	119	32	10	4	500	1,2	KMD 18	M 6	14,2
M 95x2	120	125	124	32	10	4	525	1,25	KMD 19	M 6	14,2
M 100x2	125	130	129	32	10	4	555	1,32	KMD 20	M 6	14,2
M 105x2	130	135	134	32	10	4	580	1,37	KMD 21	M 6	14,2

Indexes

Text index.....	1343
Product index	1364

Text index

A

A

- angular contact ball bearings 479, 504
- lock nuts and locking devices 1280, 1289
- motor encoder units 1161
- track runner bearings 1103, 1107, 1125

- ABMA standards 41
- abutment collars 206

- abutments
 - dimensions 208–209
 - tolerances 169, 200–202

AC 504

- AC current
 - protection with hybrid bearings 1220, 1226
 - protection with INSOCOAT bearings 1209

- AC motors 1152
- accessories 1269–1341

- acetone 1251

acids

- resistance of polymer ball bearings 1251
- resistance of seal materials 156–157

- acrylonitrile-butadiene rubber (NBR) 155
- hydrogenated acrylonitrile-butadiene rubber (HNBR) 156

ADA 580, 602

- adapter sleeves 1270–1274, 1290–1309
- axial load carrying capacity 894
- bearing seat tolerances 200–201
- coatings 1270
- designation system 1288–1289
- designs and variants 1270–1273
- dimension standards 1274
- dismounting bearings 288–289
- for CARB toroidal roller bearings 975, 1000–1003, 1273
- for inch shafts 1298–1303
- for metric shafts 1290–1297
- for oil injection 1270–1272
- for self-aligning ball bearings 546–547, 564–565, 1273
- for spherical roller bearings 898–899, 940–945, 954–955, 1273
- for Y-bearings 422–423, 427, 470–471
- mounting bearings 278
- on a stepped shaft 207, 1270
- product tables 1290–1309
- spacer rings 207, 1270
- tapers 1274
- threads 1274
- tolerances 1274
 - with inch dimensions 1304–1309

- adapters 1108, 1110

ADB 580, 602

- additives
 - in grease 244, 248, 254
 - in oil 265–266
- adjusted bearing systems 163
- adjusted reference speed 120
 - adjustment factors 121–124

- calculation examples 125
- compared to limiting speed 126

- adjusting bearings
 - angular contact ball bearings 498
 - for internal clearance 277
 - for preload 218–220
 - procedures 221–225
 - tapered roller bearings 816–817

- AFBMA standards 41

- agricultural applications
 - and Y-bearings 435, 446–447
 - specification life 83

AH 457

- alcohols 1251
- alignment needle roller bearings 683, 776–779

- cages 693–695, 714
- designs and variants 683
- dimension standards 703
- fits and tolerance classes 716
- internal clearance 702–703
- loads 711
- misalignment 52, 702–703
- mounting 718
- product tables 776–779
- temperature limits 714
- tolerances 702–703

- aliphatic hydrocarbons
 - resistance of fluoro rubber 156
 - resistance of polymer ball bearings 1251

alkalis

- resistance of polymer ball bearings 1251
- resistance of polyurethane 157

- Allen wrenches → hexagonal keys

- aluminium oxide (Al₂O₃)
 - in polymer ball bearings 1251, 1260
 - on INSOCOAT bearings (coating) 1206

- ambient temperature 240

amines 156

- ammonia 152, 154

- AMP Superseal™ connectors 1154, 1155, 1161

- angle rings 571, 604–639

- angle series 40

- angular contact ball bearings 475–535
- adjustment during mounting 221–225, 277
- assortment 476, 500–502
- axial load carrying capacity 476, 498
- bearing arrangements 160–163
- cages 480–481, 497
- combined with a needle roller bearing 684–685, 780–783
- contact angle 476, 486–487, 498, 504
- design provisions 498–499
- designation system 504–505
- designs and variants 28, 476–484
- dimension standards 486–487
- dimensional stability 497
- double row bearings 478–479, 522–529
- for universal matching 477, 500, 506–521
- four-point contact ball bearings 480, 530–535

Note: Designation prefixes and suffixes are shown in **bold**.

Text index

internal clearance 486–490
load ratio 498, 499
loads 51, 476, 492–496, 498
lubrication 497
matched bearings 478, 495, 498
misalignment 486–487
NoWear coated bearings 1244
performance classes 485
permissible speed 497
preload 215–220, 486–487, 489, 498
product tables 506–535
sealing solutions 482–483, 497, 526–529
SKF DryLube bearings 1191–1203
SKF Energy Efficient (E2) bearings 485
SKF Explorer bearings 485
temperature limits 497
tolerances 486–487
with a two-piece inner ring 479, 501
with Solid Oil 1185–1189

angular contact thrust ball bearings
designs and variants 34
loads 49

angular misalignment → misalignment
anhydrous hydrofluorides 156
annular grooves 883
ANSI standards 41
anti-fretting agents 275
anti-wear additives
for NoWear coated bearings 1245
in grease 248
in oil 265

applications
fits and tolerance classes 172–175
specification life 83

aromatic hydrocarbons
resistance of fluoro rubber 156
resistance of polymer ball bearings 1251

articulated joints 1165

A5 721

ASR 721

associated components
abutment and fillet dimensions 208–209
accuracy measurements 273
for locating bearings 205–207
provisions for mounting and dismounting 210–211
raceway specifications 210
vibration generation 128

automatic lubricators 261
automatic particle counter method 74–76, 78

AW additives → anti-wear additives
axial clamp seals 235
axial clearance 1086
axial displacement
adjustment method 222–223
considerations when selecting bearings 55
considerations when selecting fits 165, 167–168
effect of preload 219–220, 223
in bearing systems 160–162, 164, 174–175, 204
axial drive-up
measurement 282
values for CARB toroidal roller bearings 977
values for self-aligning ball bearings 549
values for spherical roller bearings 901

axial gap 1121

axial internal clearance 149–150
values for angular contact ball bearings 488–490
values for cylindrical roller bearings 591–592
values for tapered roller bearings 810

axial loads 48–51
axial location 204–209
axial play 206
axial run-out 200, 202, 210

axleboxes
fits and tolerance classes 172–173, 175
specification life 83
suitable cage types 154

B

B
angular contact ball bearings 504
lock nuts and locking devices 1289
motor encoder units 1161
polymer ball bearings 1260
sleeves 1272, 1289
tapered roller bearings 822
track runner bearings 1105–1106, 1125

B20 505

back-to-back arrangements
with angular contact ball bearings 215–216, 218, 478, 498
with deep groove ball bearings 309
with tapered roller bearings 215–216, 218, 802, 872–875

bainite-hardened rings 603
ball and cage assemblies 1010

ball bearings
compared to roller bearings 48, 54
designation system 43
base oil viscosity 246
basic dynamic load rating 63, 64–65
basic rating life 64
calculation example 90
basic static load rating 64, 88–89
bearing arrangements 160–164
bearing damage 87
electrical erosion 1206, 1223
false brinelling 1186, 1220
fretting corrosion 165
smearing 1221, 1227, 1242, 1245
spalling 1220, 1243
wear 165

bearing kits 547
bearing life → life
bearing mean diameter 23

bearing seats
dimensional accuracy 200–203
running accuracy 167, 200–202
surface roughness 204

bearing series 43, 45

bearing systems 160–164
adjusted 163
floating 164
locating/non-locating 160–162

bearing units
with Solid Oil 1185–1189
with Y-bearings 422

bearing washers → washers

bearings
handling 274
selection criteria 22, 46–59
size categories 275, 285
storage 291
terminology 23–25
types 26–36

Beast 93
Belleville washers → cup springs
bellows 226
belt drives 84
fits and tolerance classes 174
load conditions 166

BF 720

black oxide coating
on cylindrical roller bearings 575, 603
on Y-bearings 425, 435

BMB 1161

BMO 1161

bore diameter 40
tolerance definitions 134

borosilicate glass 1251, 1260

boundary dimensions 23, 40–41

Note: Designation prefixes and suffixes are shown in **bold**.

brass
 cage types 37–38
 in polymer ball bearings 1251, 1260
 material properties 152–153
BS2 884, 902

C

C
 tapered roller bearings 823
 Y-bearings 457

C08
 CARB toroidal roller bearings 978
 spherical roller bearings 903

C083 903
C084 903

C1 150
 deep groove ball bearings 315, 321

C2 150
 angular contact ball bearings 489–490, 505
 CARB toroidal roller bearings 966–967, 978
 cylindrical roller bearings 590, 603
 deep groove ball bearings 314–315, 321
 needle roller bearings 710, 721
 self-aligning ball bearings 543, 550
 spherical roller bearings 892–893, 903

C2H 505
C2L 505

C3 150
 angular contact ball bearings 489–490, 505
 CARB toroidal roller bearings 966–967, 978
 cylindrical roller bearings 590, 603
 deep groove ball bearings 314–315, 321
 needle roller bearings 710, 721
 self-aligning ball bearings 543, 550
 spherical roller bearings 892–893, 903

C3P 1228

C4 150
 angular contact ball bearings 489–490, 505
 CARB toroidal roller bearings 966–967, 978
 cylindrical roller bearings 590, 603
 deep groove ball bearings 314–315, 321
 needle roller bearings 710, 721
 spherical roller bearings 892–893, 903

C5 150
 CARB toroidal roller bearings 966–967, 978
 cylindrical roller bearings 590, 603
 deep groove ball bearings 314–315, 321
 spherical roller bearings 892–893, 903

CA
 angular contact ball bearings 477, 488, 505
 spherical roller bearings 882, 902

CAC 902

cages
 guidance 39
 lubrication considerations 240
 materials 152–155
 types 37–39

calculation tools 92–93

cam followers 1104–1110, 1140–1147
 accessories 1108–1110
 cages 1111, 1119
 designation system 1124–1125
 designs and variants 1104–1107
 dimension standards 1115
 fits and tolerance classes 1120
 internal clearance 1114–1115
 loads 1116–1117
 lubrication 1112–1113, 1119
 mounting 1106, 1120, 1122–1123
 outer ring running surfaces 1106–1107
 product tables 1140–1147
 sealing solutions 1105–1107, 1119, 1142–1147
 support surfaces 1120

temperature limits 1119
 tolerances 1114–1115, 1118

cam rollers 1100, 1126–1129
 cages 1111, 1119
 designation system 1124–1125
 designs and variants 1100
 dimension standards 1114
 double row bearings 1100, 1128–1129
 guide flanges 1121
 internal clearance 1114–1115
 loads 1116–1117
 lubrication 1112–1113, 1119
 outer ring running surfaces 1100, 1114
 product tables 1126–1129
 sealing solutions 1100, 1119, 1126–1129
 support surfaces 1120
 temperature limits 1119
 tolerances 1114–1115, 1118

capped bearings
 heating 276
 shelf life 291
 types 58
 washing 273

capping devices 24, 58–59

CARB toroidal roller bearings 957–1007
 abutment dimensions 209, 974
 applications 960, 963, 971
 assortment 960
 axial displacement 55, 964–965, 968–971, 974
 axial location 204, 1280
 bearing arrangements 162
 cages 961, 963, 973
 clearance reduction 969–971, 977
 designation system 978
 designs and variants 33, 958–963
 dimension standards 964
 dimensional stability 973
 drive-up data 977
 full complement bearings 961, 962
 housings 976
 in vertical shaft arrangements 976
 internal clearance 964–967, 968–971
 loads 959, 961, 972
 lubrication 962, 973
 measuring the inner ring expansion 283
 misalignment 964–965, 968, 970–971, 974
 mounting 963, 971, 976–977
 NoWear coated bearings 1244
 on a withdrawal sleeve 975, 1004–1007
 on an adapter sleeve 975, 1000–1003, 1273, 1280
 on start-up 972
 performance classes 963
 permissible speed 973
 preload 976
 product tables 980–1007
 roller design 959
 sealing solutions 962, 973, 996–999
 SKF Explorer bearings 963
 temperature limits 972, 973
 tolerances 964–965

carbon coating 1242, 1245

case-hardened rings 603, 822

case-hardening steels 151

CB 477, 488, 505
CC 477, 488, 505
CC(J) 882, 902
CCJA 887, 902

centralized lubrication systems 261

centrifuges 83

centring flanges
 in needle roller bearings 679
 in needle roller thrust bearings 1059, 1064, 1068

ceramics
 in hybrid bearings 1220–1221
 in polymer ball bearings 1260
 material properties 152

Note: Designation prefixes and suffixes are shown in **bold**.

Text index

- chamfers
 - boundary dimensions 40
 - dimension limits 133, 147–148
 - dimension standards 132
 - tolerance definitions 134
- chemical industry 1248
- chemical resistance
 - of cage materials 152–154
 - of polymer ball bearings 1251
 - of seal materials 155–157
- circularity 203
- circulating oil 263
 - applications 254
 - oil change interval 267
- CJ** 902
- CLO** 823
- CL00** 823
- CL7A** 823
- CL7C** 800–801, 823
- cleaning 273, 291
- clearance → internal clearance
- clearance reduction
 - from a temperature difference 214
 - from an interference fit 213–214
 - measuring with a feeler gauge 280
 - values for CARB toroidal roller bearings 977
- values for spherical roller bearings 901
- CLN** 823
- CN** 150
 - cylindrical roller bearings 603
 - deep groove ball bearings 321
 - needle roller bearings 721
- CNL** 505
- coatings 157
 - aluminium oxide (Al₂O₃) 1206
 - black oxide 425, 435, 575, 603
 - manganese phosphate 1171–1172, 1194–1195
 - molybdenum 1225
 - NoWear (carbon) 1242
 - phosphate 1270, 1276
 - polytetrafluoroethylene (PTFE) 887
 - zinc 424–425
 - zinc chromate 1225
- coefficient of friction 98
- coefficient of thermal expansion
 - considerations when selecting fits 168, 170
 - of polymers in polymer ball bearings 1256–1257
 - of silicon nitride compared to steel 1221
- cold dismantling 285
- combined loads 50–51
- combined needle roller bearings 683–690, 780–789
 - abutment dimensions 715
 - cages 693–695, 714
 - designs and variants 683–690
 - dimension standards 704–705
 - fits and tolerance classes 717
 - internal clearance 704–705
 - loads 712–713
 - lubrication 699, 714
 - misalignment 704–705
 - product tables 780–789
 - sealing solutions 698, 784–789
- compressed air 1176
- compressors
 - and hybrid bearings 1221
 - and NoWear coated bearings 1243
 - suitable cage types 152, 154
- ConCentra Y-bearings → SKF ConCentra Y-bearings
- cones 798, 821
- connecting rods 165, 676
- consistency 246
 - effect of mixing greases 249
 - effect of temperature changes 244–245
- contact angle 25
 - angle series 40
 - effect on axial load carrying capacity 50
 - in angular contact ball bearings 476, 486–487
 - in tapered roller bearings 798, 820, 822
- contact seals 228–230, 234–236
- contact stresses 64
- contamination
 - effect on relubrication interval 253
 - ISO classification 74–75, 78
- contamination factor 74–80
- contamination levels
 - for grease lubrication 74, 76
 - for oil lubrication 74, 77
- continuous casters 960
- continuous relubrication 253–254, 258, 261
- conveyors
 - and track runner bearings 1100
 - fits and tolerance classes 172–174
 - load conditions 166
 - specification life 83
- cooling factor 114
- coronet cages 1171
- corrosion resistance
 - of grease 248
 - of NoWear coated bearings 1243
 - of polymer ball bearings 1248
 - of stainless steel deep groove ball bearings 296
- cranes
 - fits and tolerance classes 174
 - load conditions 87
 - specification life 83
- crank pins 676
- creep 165–166
 - with polymer ball bearings 1248
- cross-locating bearing systems
 - adjusted 163
 - floating 164
 - located axially 204
- crushers
 - load conditions 166
 - specification life 83
- cryogenic temperatures 1225
- CS** 884, 902
- CS2** 884, 902
- CSS**
 - CARB toroidal roller bearings 962, 978
 - spherical roller bearings 884, 902
- cup springs 236, 686, 690
- cups 798, 821
- CV** 602
- cylindrical roller and cage thrust assemblies 1039, 1042, 1046
- cylindrical roller bearings 567–671
 - applications 569, 575
 - axial displacement 55, 585, 588–589
 - axial load carrying capacity 583, 596–597
 - axial location 204
 - bearing arrangements 160–161, 164
 - cages 575–577, 582, 599
 - designation system 602–603
 - designs and variants 29–30, 568–582
 - dimension standards 584, 586–587
 - dismantling 286
 - double row bearings 577, 579–581, 656–671
 - full complement bearings 578–581, 644–671
 - high-capacity bearings 575–577, 640–643
 - hybrid bearings 1224, 1238–1239
 - INSOCOAT bearings 1205–1211, 1214–1217
 - internal clearance 584, 586–587, 590–592
 - loads 48, 50, 594–597
 - lubrication 254, 580–581, 599
 - matched bearings 581
 - misalignment 585–587
 - mounting 276, 601
 - NoWear coated bearings 1244
 - performance classes 583
 - permissible speed 600
 - preload considerations 221
 - product tables 604–671

Note: Designation prefixes and suffixes are shown in **bold**.

- sealing solutions 579–581, 599, 668–671
- SKF DryLube bearings 1191–1203
- SKF Energy Efficient (E2) bearings 583
- SKF Explorer bearings 583
- temperature limits 599
- tolerances 584, 586–587
- with a retaining ring 578, 579, 602
- with a snap ring groove 573, 580
- with an angle ring 571, 604–639
- with an extended inner ring 574
- with locating slots 573
- with Solid Oil 1185–1189
- cylindrical roller thrust bearings 1037–1055
 - abutment dimensions 1046
 - cages 1040, 1045
 - combined with a needle roller bearing 689–690, 788–789
 - designation system 1047
 - designs and variants 34, 1038–1040
 - dimension standards 1041
 - double direction bearings 1038–1039
 - fits and tolerance classes 1046
 - loads 47, 49, 1044
 - misalignment 1041
 - permissible speed 1045
 - product tables 1048–1055
 - single direction bearings 1038
 - temperature limits 1045
 - tolerances 1041–1043
 - washers 1038–1039, 1042, 1045, 1046
 - with raceways on shafts and in housings 1046

D

D

- angular contact ball bearings 479, 504
- needle roller bearings 720
- polymer ball bearings 1260
- sleeves 1289

D/W 320

DA 581, 602

DB

- angular contact ball bearings 505
- deep groove ball bearings 321
- tapered roller bearings 823

DC current

- protection with hybrid bearings 1220, 1226
- protection with INSOCCOAT bearings 1206, 1209

deep groove ball bearings 295–419

- axial displacement 55
- bearing arrangements 160–162
- cages 298–299, 318
- designation system 320–321
- designs and variants 26, 296–309
- dimension standards 312–313
- dimensional stability 318
- double row bearings 298, 416–419
- for extreme temperatures 1170–1181
- grease life 306–307
- hybrid bearings 1223, 1230–1237
- in sensor bearing units 1151–1167
- INSOCCOAT bearings 1205–1213
- internal clearance 312–315
- loads 50–51, 316–317
- lubrication 304–305, 318
- matched bearings 309, 318
- misalignment 312–313
- NoWear coated bearings 1244
- performance classes 310
- permissible speed 53, 318
- polymer ball bearings 1247–1265
- preload considerations 215, 221, 224
- product tables 322–419
- sealing solutions 230, 300–307, 318, 346–375
- SKF DryLube bearings 1191–1203

- SKF Energy Efficient (E2) bearings 310
- SKF Explorer bearings 310
- SKF Quiet Running bearings 309
- stainless steel bearings 296–297, 386–409
- temperature limits 300, 318
- tolerances 312–313
- with a snap ring groove 308, 376–385, 414–415
- with filling slots 297, 410–415
- with Solid Oil 1185–1189
- defect frequencies → skf.com/bearingcalculator
- density 1220–1221
- designation systems 42–45

DF

- angular contact ball bearings 505
- deep groove ball bearings 321
- tapered roller bearings 823
- dial indicators 277, 282
- diameter series
 - identification 132, 136
 - in ISO general plans 40–41, 42–43
- dielectric constant 152
- differentials
 - and tapered roller bearings 800
 - preload considerations 214, 217
 - stiffness 54
- dimension series 40–41, 42–43
- dimensional accuracy
 - of bearings 132–135, 137–148
 - of seats and abutments 200–203
- dimensional stability 82
- direct drive control 1165
- direction of load indeterminate 165, 172–175
- dismounting 285–290
 - cold 285
 - considerations when selecting bearings 56–57
 - considerations when selecting fits 168
 - design provisions 210–211
 - from a cylindrical shaft seat 285–286
 - from a tapered shaft seat 287
 - from a withdrawal sleeve 290
 - from an adapter sleeve 288–289
 - with heat 286
- distance rings 24
- double direction bearings
 - angular contact thrust ball bearings 34, 49, 53
 - cylindrical roller thrust bearings 34, 1038–1039
 - needle roller thrust bearings 34, 1058–1059
 - thrust ball bearings 33, 48, 1010–1011
- double row angular contact ball bearings 478–479, 522–529
 - assortment 501
 - bearing arrangements 160–161
 - cages 481, 497
 - contact angle 487
 - designation system 504–505
 - designs and variants 478–479, 481–483
 - dimension standards 487
 - dimensional stability 497
 - internal clearance 487, 489
 - loads 492–493
 - lubrication 482–483
 - misalignment 486–487
 - product tables 522–529
 - sealing solutions 482–483, 526–529
 - temperature limits 497
 - tolerances 486–487
- double row cam rollers 1100, 1128–1129
 - cages 1111, 1119
 - design 1100
 - designation system 1124–1125
 - dimension standards 1114
 - dimensional stability 1119
 - internal clearance 1114–1115
 - loads 1116–1117
 - lubrication 1112–1113
 - outer ring running surfaces 1100, 1114
 - product table 1128–1129

Note: Designation prefixes and suffixes are shown in **bold**.

Text index

- sealing solutions 1100, 1119, 1128–1129
 - temperature limits 1119
 - tolerances 1114–1115, 1118
 - double row cylindrical roller bearings 579–581, 656–671
 - axial displacement 588–589
 - designs and variants 577, 579–581
 - dimension standards 587
 - dimensional stability 599
 - high-capacity bearings 577
 - internal clearance 586–587, 590
 - loads 594–597
 - lubrication 580–581, 599
 - misalignment 586–587
 - product tables 656–671
 - sealing solutions 580–581, 599, 668–671
 - temperature limits 599
 - tolerances 586–587
 - double row deep groove ball bearings 298, 416–419
 - cages 298–299, 318
 - designation system 320–321
 - designs and variants 298
 - dimension standards 313
 - dimensional stability 318
 - internal clearance 312–314
 - loads 298, 316–317
 - misalignment 312–313
 - permissible speed 318
 - product table 416–419
 - temperature limits 318
 - tolerances 312–313
 - with Solid Oil 1185–1189
 - double row needle roller bearings
 - drawn cup needle roller bearings 678
 - needle roller and cage assemblies 675
 - with machined rings 681–682
 - double row tapered roller bearings 800
 - DR** 581, 603
 - drag losses 100, 110–112
 - drawn cup needle roller bearings 677–679, 730–743
 - cages 693–695, 714
 - designs and variants 677–679
 - dimension standards 701
 - dimensional stability 714
 - double row bearings 678
 - fits and tolerance classes 716
 - in combination with a needle roller thrust bearing 1060
 - loads 711
 - lubrication 679, 699
 - misalignment 700–701
 - mounting 718
 - product tables 730–743
 - sealing solutions 696–697, 730–743
 - temperature limits 714
 - tolerances 701, 707
 - drifts 285
 - drive-up → axial drive-up
 - drive-up method → SKF Drive-up Method
 - dropping point 244
 - dry lubricants
 - in bearings for extreme temperatures 1171
 - in SKF DryLube bearings 1192, 1195, 1201
 - dry running 1243
 - drying cylinders
 - and CARB toroidal roller bearings 971
 - fits and tolerance classes 175
 - DryLube bearings → SKF DryLube bearings
 - DS** 720
 - DT**
 - angular contact ball bearings 505
 - deep groove ball bearings 321
 - tapered roller bearings 823
 - dust 300
 - duty intervals 81, 85–86
 - calculation example 91–92
 - dynamic bearing loads 84–86
 - dynamic load rating 63
 - dynamic load safety factor 1201
 - dynamic seals 226
- ## E
- E**
 - angular contact ball bearings 504
 - deep groove ball bearings 320
 - self-aligning ball bearings 550
 - sleeves 1273, 1289
 - spherical roller bearings 882–883, 887, 902
 - spherical roller thrust bearings 1078, 1088, 1089
 - E2**
 - angular contact ball bearings 485, 504
 - cylindrical roller bearings 583, 602
 - deep groove ball bearings 310, 320
 - spherical roller bearings 883, 889, 896, 902
 - tapered roller bearings 804, 822
 - Y-bearings 438, 456
 - EC** 602
 - eccentric collars 1104, 1122
 - eccentric locking collars 425, 464–467
 - EGS** 720
 - EH** 1273, 1289
 - EJA** 887, 902
 - EL** 1273, 1289
 - elastic deformation 217–220
 - elasto-hydrodynamic lubrication 99
 - electric current
 - protection with hybrid bearings 1220, 1226
 - protection with INSOCOAT bearings 1206, 1207, 1209
 - electric motors
 - and hybrid bearings 1220, 1222, 1224
 - and INSOCOAT bearings 1206
 - and NoWear coated bearings 1243
 - fits and tolerance classes 172–175
 - motor encoder units 1157
 - preload considerations 214, 224–225
 - specification life 83
 - electric vehicles 1165
 - electrical erosion
 - protection with hybrid bearings 1223
 - protection with INSOCOAT bearings 1206
 - electrical industry 1248
 - electromagnetic environments 1155
 - encoder units
 - motor encoder units 1152–1161
 - roller encoder units 1162
 - steering encoder units 1163–1164
 - end plates 24, 205, 207
 - energy efficient bearings → SKF Energy Efficient (E2) bearings
 - envelope requirement 169
 - EP additives → extreme pressure additives
 - equivalent dynamic bearing load 85–86
 - equivalent static bearing load 88
 - escape holes → grease escape holes
 - esters 154, 156
 - ethers 156
 - excitation 128
 - exciters 888
 - Explorer bearings → SKF Explorer bearings
 - extended inner rings
 - in cylindrical roller bearings 574
 - in self-aligning ball bearings 538, 540
 - in Y-bearings 422, 424–427
 - external forces 84
 - external seals 231–236
 - extreme pressure additives
 - effect on cage materials 154
 - effect on viscosity ratio 73
 - for NoWear coated bearings 1245
 - in grease 248, 254
 - in oil 265, 266

Note: Designation prefixes and suffixes are shown in **bold**.

extreme temperature bearings 1169–1183
 applications 1171
 associated components 1175
 assortment 1170
 deep groove ball bearings 1170–1181
 designation system 1176
 designs and variants 1170–1172
 dimension standards 1173
 internal clearance 1171, 1173–1174
 limiting speed 1171
 loads 1171, 1174
 lubrication 1171, 1176
 maintenance 1176
 misalignment 1173
 mounting 1173
 product tables 1178–1183
 running-in period 1171
 sealing solutions 1171–1172, 1175
 temperature limits 1171
 tolerances 1173–1174
 Y-bearings 1170–1176, 1182–1183
 eye bolts 274, 903

F

F

angular contact ball bearings 481, 504
 bearings for extreme temperatures 1176
 spherical roller bearings 902
 spherical roller thrust bearings 1089
 thrust ball bearings 1011, 1015
 Y-bearings 429, 457

F1 1228

F3 1089

FA

angular contact ball bearings 504
 spherical roller bearings 902

face-to-face arrangements
 with angular contact ball bearings 215–216, 218, 478, 498
 with deep groove ball bearings 309
 with tapered roller bearings 215–216, 218, 802, 866–871

failure 63

failure probability 63, 65

false brinelling 1220

fans 958, 1243

fastening elements 1278–1279

fatigue → metal fatigue

fatigue load limit 64–65

feeler gauges 280

felt seals 236

fillets 208

filling grade → grease fills

filling slot bearings 297, 410–415

cages 298–299, 318

designs and variants 297, 308

dimension standards 312–313

dimensional stability 318

internal clearance 312–314

loads 297, 316–317

misalignment 312–313

permissible speed 297, 318

product tables 410–415

sealing solutions 301, 308, 410–415

temperature limits 318

tolerances 312–313

with a snap ring groove 308, 414–415

filter rating 74–75

filtration ratio 76–77

fits

for housings 171, 174–175

for shafts 171–174, 176–177

selection criteria 165–168

tolerance tables 178–199

fitting slots 454

five-lip (5-lip) seals 430, 435

FKM → fluoro rubber (FKM)

flange rings 1102–1104, 1105–1107

flanged bearings 801, 822, 864–865

flanges

in cylindrical roller bearings 570–574, 578, 579–580

in needle roller bearings 680–681, 688, 718

in spherical roller bearings 882–883

in tapered roller bearings 798–801, 817

flingers

in Y-bearings 429

with grease lubrication 259

with oil lubrication 232–233

floating bearing systems 164

fluctuating loads 81

fluoro rubber (FKM) 156

food and beverage industry

and bearings with Solid Oil 1187

and polymer ball bearings 1248

and SKF DryLube bearings 1193

and Y-bearings 424

food-compatible seals 424

food-grade lubricants

in bearings with Solid Oil 1187

in SKF DryLube bearings 1195

in Y-bearings 424, 431, 434

form tolerances → geometrical tolerances

four-point contact ball bearings 480, 530–535

assortment 502

cages 481

contact angle 487

design 480–481, 484

designation system 504–505

dimension standards 487

dimensional stability 497

in vertical shaft arrangements 499

internal clearance 487, 490, 499

load ratio 499

loads 492–493

misalignment 486–487

product table 530–535

temperature limits 497

tolerances 486–487

with locating slots 484, 499, 530–535

four-row tapered roller bearings 800

frequency converters 1206

fretting corrosion 165

friction 97–115

considerations when selecting bearings 54

frictional moment

drag losses 100, 110–112

effect of clearance/preload 212

estimation 98

influencing factors 113

of seals 109

of SKF Energy Efficient (E2) bearings 113

power loss 114

preload adjustment method 224

rolling frictional moment 100–102, 104–108

running-in period 113

sliding frictional moment 103–108

starting torque 114

fuel pumps 1221

full complement bearings

CARB toroidal roller bearings 961, 962

combined needle roller bearings 685–687, 784–785

double row cylindrical roller bearings 579–581, 656–671

needle roller bearings 677–679

polymer ball bearings 1248–1249, 1260

single row cylindrical roller bearings 578, 644–655

full-film lubrication 241

effect on sliding frictional moment 103

furnaces 569

Note: Designation prefixes and suffixes are shown in **bold**.

Text index

G

G
angular contact ball bearings 477, 488, 505
sleeves 1289
Y-bearings 457
G2 708, 721
GA 477, 489, 505
gap-type seals 228, 231
gasoline 1251
gauges
for associated components 203, 273
for needle rollers 707–709
GB 477, 489, 505
GC 477, 489, 505
gears
and NoWear coated bearings 1243
design provisions 206, 217
fits and tolerance classes 172–173
load conditions 81, 84
specification life 83
GEM9
CARB toroidal roller bearings 962, 978
spherical roller bearings 885, 903
general plans 40–41
generators
and hybrid bearings 1220, 1222, 1223
and INSOCOAT bearings 1206
specification life 83
geometric centres 814
geometrical tolerances
for bearings 132–135, 137–144
for seats and abutments 200–203
g-forces 1186
GJN 304–305, 321
glass 1250, 1251, 1260
glass fibre reinforced polymers 153–155
gloves 274
glycol 1171
GPS tracking systems 1165
GR 457
graphite
as a dry lubricant 1171, 1192, 1195, 1203
as a solid lubricant additive 248, 254
grease escape holes 259, 260
grease fills
effect on frictional moment 113
initial fill 242, 248
renewal 260
replenishment 258, 260
grease fittings 1108–1109
grease life 252
for capped deep groove ball bearings 306–307
for capped Y-bearings 432–433
for sealed hybrid bearings 1223
for sealed spherical roller bearings 885
grease lubrication 242–261
bearing operating conditions 242–243
contamination levels 74–76
effect on reference speed 120
greases 244–251

protection against corrosion 248
relubrication 252–261
running-in period 242
grease performance factor 305–306
greases
additives 248
base oil viscosity 246
consistency classes 246
load carrying ability 248
miscibility 248–249
SKF greases 247, 249–251
SKF traffic light concept 244–247
grinding spindles

and sensor bearing units 1165
preload considerations 225
stiffness 54
grub screw locking 424–425, 458–462
grub screws 448–449, 452, 454
G5
cylindrical roller thrust bearings 1039, 1042, 1047
needle roller thrust bearings 1061, 1068, 1069
gudgeon pins 676
guide flanges 25, 1121
guide rings 881, 882–883
guiding sleeves 276
GWF 483, 505

H

H
lock nuts and locking devices 1289
needle roller bearings 721
sleeves 1271, 1289
HA1
cylindrical roller bearings 603
tapered roller bearings 822
HA3
CARB toroidal roller bearings 978
cylindrical roller bearings 603
spherical roller bearings 903
tapered roller bearings 822
Hall effect cells 1153, 1155, 1164
halogenic hydrocarbons 1251
hardness
of bearing steels 151–152
of NoWear 1242
of raceways on shafts and in housings 210
of seal counterfaces 234
of silicon nitride 152, 1220–1221
HB 1272, 1289
HB1
cylindrical roller bearings 603
cylindrical roller thrust bearings 1047
HC5 1228
heat flow density 118–119
heat stabilization 151
classes 82
heat treatment 151–152
heating rings 286
height 40
tolerance definitions 135
height series 40, 42–43
hexagonal keys
for track runner bearings 1106–1107, 1122
for Y-bearings 451–452, 454
hexagonal nuts 1108–1109, 1122
high temperature bearings → extreme temperature bearings
high-capacity bearings 575–577, 640–643
HN1
cylindrical roller bearings 603
tapered roller bearings 822
HN3 822
HNBR → hydrogenated acrylonitrile-butadiene rubber (HNBR)
hollow shafts 176–177
hook spanners 278, 290, 453
hot dismounting 286
hot mounting 276
hotplates 276
housing bore diameter 24
housing covers 24, 205
housing seats 24, 171
housing washers 25
in cylindrical roller thrust bearings 1038–1039, 1042, 1045, 1046
in needle roller thrust bearings 1060–1061, 1068
in spherical roller thrust bearings 1078–1079, 1084
in thrust ball bearings 1010–1011, 1014

Note: Designation prefixes and suffixes are shown in **bold**.

housings 24
 fits and tolerance classes 174–175
 for CARB toroidal roller bearings 976
 for self-aligning ball bearings 547
 for spherical roller bearings 899
 resultant fits 190–199

HR 1260

HT 304–305, 321

hub units
 and tapered roller bearings 800
 fits and tolerance classes 174
 load conditions 166
 material properties 151

humidity 291

HV 424, 457

hybrid bearings 1219–1239
 assortment 1222
 axial displacement 1226
 cages 1221, 1225, 1228
 coatings 1225
 compared to bearings with
 steel rolling elements 1220–1221, 1223, 1227
 considerations for frictional moment 113
 cylindrical roller bearings 1224, 1238–1239
 deep groove ball bearings 1223, 1230–1237
 designation system 1228
 designs and variants 1220–1225
 dimension standards 1226
 dimensional stability 1228
 electrical properties 1220, 1226
 for very low temperatures 1221
 internal clearance 1226
 loads 1227
 lubrication 241, 1220–1221, 1223, 1228
 misalignment 1226
 performance class 1223
 permissible speed 1221, 1228
 preload 1220, 1227
 product tables 1230–1239
 quiet running bearings 1227
 sealing solutions 1222, 1223, 1228, 1232–1235
 SKF Explorer bearings 1223
 temperature limits 1221, 1225, 1228
 tolerances 1226

hybrid vehicles 1165

hydraulic fluids 156

hydraulic nuts
 for adapter sleeves 1270, 1290–1309
 for dismounting bearings 288–290
 for mounting bearings 278–279, 282
 for withdrawal sleeves 1275, 1310–1315

hydraulic pumps 1243

hydrocarbons 1251

hydrodynamic films
 effect of speed 127
 effect of temperature 125
 effect of viscosity 241, 265

hydrofluoric acid 1251

hydrogenated acrylonitrile-butadiene rubber (HNBR) 156

and Y-bearings 460–462, 466–467, 469, 471

inch sleeves 1270–1272, 1304–1309

induction heaters
 for dismounting bearings 286
 for INSOCOAT bearings 1210
 for motor encoder units 1159
 for mounting bearings 276

induction-hardening steels 151

inductive sensors 1154

inertia 1220

initial clearance 149

injection moulded cages 153

inlet shear heating reduction factor 100–101

inner ring expansion 283

inner ring raceways 25

inner ring shoulder surface 24

inner ring side faces 25

inner rings 24
 for needle roller bearings 691–692, 790–793

insert bearings → Y-bearings

INSOCOAT bearings 1205–1217
 abutment dimensions 1210
 assortment 1207
 cages 1208
 cylindrical roller bearings 1207, 1214–1217
 deep groove ball bearings 1207, 1212–1213
 designation system 1211
 designs and variants 1206–1208
 dimension standards 1209
 electrical properties 1209
 internal clearance 1209
 loads 1210
 misalignment 1209
 mounting 1210
 permissible speed 1210
 product tables 1212–1217
 sealing solutions 1208
 temperature limits 1210
 tolerances 1209

inspection 291

insulation
 with hybrid bearings 1220, 1226
 with INSOCOAT bearings 1206
 with polymer ball bearings 1248

integral bearing seals 58–59, 229–230

integral bearing shields 58, 229
 in deep groove ball bearings 300–301, 308

interference fits
 in the ISO tolerance system 170
 resulting clearance reduction 213–214
 when mounting bearings 280–283

intermediate washers
 in cylindrical roller thrust bearings 1038–1039
 in needle roller thrust bearings 1058–1059

internal clearance 149–150
 considerations when selecting fits 167
 effect on frictional moment 113
 selection 212–225
 versus preload 212–213

internal gauges 273

internal loads 160

IS 692, 721

ISO
 contamination classification 74–75, 78
 envelope requirement 169
 general plans 40–41
 reference speed 118
 tolerance grades 201
 tolerance system 169–170
 viscosity grades 71

ISR 721

Note: Designation prefixes and suffixes are shown in **bold**.

Text index

J

- J
- angular contact ball bearings 480, 504
- cylindrical roller bearings 582, 602
- spherical roller bearings 902
- tapered roller bearings 822
- JA**
 - cylindrical roller bearings 602
 - spherical roller bearings 902
- JB** 582, 602

K

- K**
 - CARB toroidal roller bearings 960, 978
 - cylindrical roller bearings 573, 602
 - cylindrical roller thrust bearings 1039, 1042, 1047
 - polymer ball bearings 1260
 - spherical roller bearings 882, 902
 - Y-bearings 457
- K30**
 - CARB toroidal roller bearings 960, 978
 - spherical roller bearings 882, 902
- ketones 156
- key slots 1278, 1280–1281, 1289
- keys → hexagonal keys
- keyways 1278, 1280–1281
- kilns
 - and bearings for extreme temperatures 1176
 - and SKF DryLube bearings 1193
- kinematic replenishment/starvation 100, 102
- kinematic viscosity → viscosity

L

- L**
 - cylindrical roller bearings 602
 - lock nuts and locking devices 1289
 - polymer ball bearings 1260
 - sleeves 1273, 1289
- L4B** 575, 603
- L5B** 603
- L5DA** 1242, 1244, 1245
- L7B** 603
- L7DA** 1242, 1244, 1245
- labyrinth seals 228, 232
- large bearings 275, 285
 - effect on relubrication interval 254
- LHT23** 304–305, 321
- life
 - calculation examples 90–92
 - definition 63
 - equations 64–83
 - testing 95
 - unit conversion table 70
 - with variable operating conditions 81
- life adjustment factor 65
- life modification factor 64–70, 73
- lifting tackle 274, 903
- limiting speed 126
 - compared to reference speed 118
- linear bearings 45
- load ratings 63–64
- load ratio
 - for angular contact ball bearings 498
 - for four-point contact ball bearings 499
- loads
 - conditions 165–166
 - considerations when selecting bearings 48–51
 - effect on relubrication interval 254
 - ranges for grease lubricated bearings 243
- locating bearings
 - axial displacement 55
 - axial location 204
 - in bearing systems 160–161
- locating notches → locating slots
- locating slots
 - in angular contact ball bearings 484
 - in cylindrical roller bearings 573
 - in deep groove ball bearings 320
- locating/non-locating bearing systems 160–162
- location
 - axial 204–209
 - radial 165–204
- lock nut tightening angle 281
 - values for CARB toroidal roller bearings 977
 - values for self-aligning ball bearings 549
 - values for spherical roller bearings 901
 - values for Y-bearings 453
- lock nuts
 - designation system 1288–1289
 - designs and variants 1278–1282
 - dimension standards 1284–1285
 - for CARB toroidal roller bearings 1273
 - for sealed bearings 1273
 - installation and removal 1286–1287
 - loosening torque 1284–1285
 - mating shaft threads 1284–1285
 - precision lock nuts 1281–1282, 1286–1287, 1336–1340
 - product tables 1316–1340
 - tolerances 1284–1285
 - with a locking screw 1280, 1334–1335
 - with an integral locking device 1280, 1333
 - with inch dimensions 1278, 1284, 1326–1328
- lock washers
 - design 1278–1279
 - installation and removal 1286
 - product tables 1318–1319, 1330–1331
- locking clips
 - design 1278–1279
 - installation and removal 1286
 - product table 1324–1325
- locking plates
 - design 1278–1279
 - installation and removal 1286
 - product table 1332
- logarithmic profile
 - in cylindrical roller bearings 568–569
 - in tapered roller bearings 798, 800
- loose fits 170
- low-friction bearings → SKF Energy Efficient (E2) bearings
- low-friction seals 300, 302
- LS** 602
- LT** 304–305, 321
- LT10** 304–305, 321
- lubricant films
 - effect of inlet shearing 101
 - effect of kinematic starvation 102
 - effect on frictional moment 99
 - formation 241, 265
- lubricants
 - dry lubricants 1192, 1195
 - effect on polyamide 66 cages 153–154
 - function 240
 - greases 244–251
 - oils 265–266
 - Solid Oil 1186–1187
- lubricated for life
 - bearings for extreme temperatures 1176
 - capped bearings 58
- lubrication 239–269
 - effect on frictional moment 99–102, 103
 - grease 242–261
 - oil 262–269
- lubrication holes 883, 886, 887

Note: Designation prefixes and suffixes are shown in **bold**.

M

M

- angular contact ball bearings 481, 504
- CARB toroidal roller bearings 961, 963, 978
- cylindrical roller bearings 582, 602
- cylindrical roller thrust bearings 1040, 1047
- deep groove ball bearings 299, 318, 320
- INSOCOAT bearings 1208
- polymer ball bearings 1260
- self-aligning ball bearings 541, 550
- spherical roller thrust bearings 1089
- thrust ball bearings 1011, 1015

M../M.. 721

MA

- angular contact ball bearings 481, 504
- cylindrical roller bearings 582, 602
- deep groove ball bearings 299, 318, 320
- four-point contact ball bearings 499, 504
- spherical roller bearings 902

MA(S) 320

machine tools

- fits and tolerance classes 172–173
- load conditions 87
- preload considerations 214, 225
- specification life 83
- stiffness 54

machined metal cages

- material properties 153
- types 38

magnet motors 1165

magnetic fields 152

magnetic sensors

- motor encoder units 1152–1153
- steering encoder units 1164

maintenance-free

- deep groove ball bearings 300
- hybrid bearings 1223
- self-aligning ball bearings 540

mandrels 1122

manganese phosphate coating

- on bearings for extreme temperatures 1171–1172
- on SKF DryLube bearings 1193–1194

marginal lubrication 1243

marine applications 1243

matched bearings

- angular contact ball bearings 477, 505
- cylindrical roller bearings 581
- deep groove ball bearings 309, 321
- tapered roller bearings 802–803, 814–815, 823, 866–877

materials

- for cages 152–155
- for coatings 157
- for polymer ball bearings 1250–1251, 1260
- for raceways on shafts and in housings 210
- for rings and rolling elements 151–152
- for seals 155–157

MB

- CARB toroidal roller bearings 961, 963, 964, 978
- cylindrical roller bearings 582, 602
- deep groove ball bearings 299, 318, 320

MB(S) 320

MB1 978

- mean loads 85–86
- mechanical seals 234–235

medical applications

- and polymer ball bearings 1248
- specification life 83

medium-size bearings 275, 285

membranes 226

metal fatigue

- causes 62
- effect of contamination 74–75
- effect on bearing life 63

metals industry 1193, 1201

metal-to-metal contact

- in NoWear coated bearings 1245
- in SKF DryLube bearings 1192
- prevention 248

metric bearings 40–41

MH 582, 602

micrometers 273

microscope counting method 74–78

mills

- and cylindrical roller bearings 569
- fits and tolerance classes 172–173
- specification life 83

mineral oils 265

- in grease 247
- resistance of polymer ball bearings 1251
- minimum load 86

mining applications 83

misalignment

- considerations when selecting bearings 52
- effect on frictional moment 113

miscibility 248–249

mixed lubrication 99, 103

ML

- cylindrical roller bearings 582, 602
- INSOCOAT bearings 1208

modulus of elasticity 152

moisture

- protection with deep groove ball bearings 296
- protection with INSOCOAT bearings 1206
- resistance of polymer ball bearings 1248

molybdenum disulfide (MoS₂)

- as a solid lubricant additive 248, 254
- in SKF DryLube bearings 1192, 1194

moment loads 51

motor encoder units 1152–1161

axial location 1158

bearings 1152

cable connection 1152, 1154, 1157, 1160

cages 1156, 1161

design provisions 1157–1158

designation system 1161

designs and variants 1152–1154

dimension standards 1156

dimensional stability 1156

electromagnetic compatibility 1155

filtering 1155

for extreme operating conditions 1154

internal clearance 1156

lubrication 1154, 1156

mounting 1158, 1159–1160

output signal features 1154–1155

permissible speed 1157

power supply 1155

receiving interface requirements 1154–1155

resistors 1155, 1157

sealing solutions 1152, 1153, 1156

temperature limits 1156–1157

tolerances 1156

voltage supply 1155, 1157

mounting 271–284

bearings with a cylindrical bore 275–277

bearings with a tapered bore 278–284

cold 275

considerations when selecting bearings 56–57

considerations when selecting fits 168

design provisions 210–211

measuring the axial drive-up 282

measuring the clearance reduction 280–281

measuring the inner ring expansion 283

measuring the lock nut tightening angle 281

using heat 276

using the oil injection method 279

mounting dollies

for dismounting bearings 288

for mounting bearings 275–276, 718

MP 602

Note: Designation prefixes and suffixes are shown in **bold**.

Text index

MR 602

MT33

angular contact ball bearings 483, 505
deep groove ball bearings 304–305, 321

MT47 304–305, 321

N

N

angular contact ball bearings 504
cylindrical roller bearings 573, 602
deep groove ball bearings 308, 320
polymer ball bearings 1260

N/M 721

N1

angular contact ball bearings 484, 504
cylindrical roller bearings 573, 602
deep groove ball bearings 320
spherical roller thrust bearings 1089

N2

angular contact ball bearings 484, 504
cylindrical roller bearings 573, 602
spherical roller thrust bearings 1089

nano particles 1194–1195

NBR → acrylonitrile-butadiene rubber (NBR)

needle roller and cage assemblies 674–676, 722–728

abutment dimensions 715
cages 693–695, 714
designs and variants 674–676
dimension standards 700
double row bearings 675
fits and tolerance classes 709
in cam followers 1105
in support rollers 1101–1102
internal clearance 700
loads 711
misalignment 700–701
product tables 722–728
tolerances 700

needle roller and cage thrust assemblies

designs 1058–1059
fits and tolerance classes 1068
product table 1070–1073
tolerances 1064

needle roller bearings 673–794

applications 676
axial displacement 55
axial location 204
cages 693–695, 714
combined with a cylindrical roller thrust bearing 689–690, 788–789
combined with a full complement bearing 685–687, 784–785
combined with a needle roller thrust bearing 679, 682, 1060
combined with a thrust ball bearing 685–688, 784–787
combined with an angular contact ball bearing 684–685, 780–783
design provisions 714–718
designation system 720–721
designs and variants 30–32, 674–699
dimension standards 700–706
dimensional stability 714
dismounting 286
fits and tolerance classes 716–717
full complement bearings 677–679
gauges 707–709, 718
inner rings 691–692, 790–793
internal clearance 700–706, 710
loads 48, 711–713
lubrication 696–699, 714
misalignment 700–705
mounting 276, 718
needle rollers 692, 794
NoWear coated bearings 1244
permissible speed 714

product tables 722–794
sealing solutions 696–698, 714
sealing rings 683, 714
space considerations 47
temperature limits 714
tolerances 700–709
with machined rings 680–682, 744–775
with Solid Oil 1186

needle roller thrust bearings 1057–1075

abutment dimensions 1068
cages 1062, 1067
combined with a needle roller bearing 679, 682, 1060
designation system 1069
designs and variants 34, 1058–1062
dimension standards 1063
dimensional stability 1067
double direction bearings 1058–1059
fits and tolerance classes 1068
loads 49, 1066
misalignment 1063
permissible speed 1067
product tables 1070–1075
raceways on shafts and in housings 1068
temperature limits 1067
tolerances 1063–1065
washers 1060–1061, 1064, 1067, 1068
with a centring flange 1059, 1064, 1068, 1074–1075

needle rollers 692

dimension standards 706
gauges 707
product table 794
tolerances 706, 708
negative operating clearance → preload
NLGI 246

noise

effect of preload 217, 224
generation at high speeds 128
reduction by spring loading 1227

non-contact seals 228, 231–233

non-locating bearings

axial displacement 55, 168
axial location 204
in bearing systems 160–161

non-separable bearings

dismounting 285
mounting 275

Normal clearance 150

values for angular contact ball bearings 489–490
values for CARB toroidal roller bearings 966–967
values for deep groove ball bearings 314–315
values for spherical roller bearings 892–893

Normal tolerances 133

NoWear 1242

NoWear coated bearings 1241–1245

applications 1243
assortment 1244
coatings 1242, 1245
designation system 1245
designs and variants 1245
loads 86, 1245
lubrication 1245
operating conditions 1242
permissible speed 1245
temperature limits 1245

NR

angular contact ball bearings 504
cylindrical roller bearings 602
deep groove ball bearings 308, 320

NSF H1 approved lubricants

in bearings with Solid Oil 1187
in SKF DryLube bearings 1195

Note: Designation prefixes and suffixes are shown in **bold**.

O

ocean-going vessels 83
off-highway vehicles 1163, 1165
office products 1248
offset mounting 971
offshore applications 1243
ohmic resistance 1209
oil bath 262
 calculating the frictional moment 100, 102, 110–111
 drag losses 110–111
 load conditions 254
 oil change interval 267
oil contamination codes 76
oil distribution grooves
 dimensions 211
 in adapter sleeves 1270–1272
 in withdrawal sleeves 1276
 oil injection method (dismounting) 287
 oil injection method (mounting) 279
oil injection method 279
 dimensions for ducts, grooves and holes 211
 for dismounting bearings 285, 287–290
 for mounting bearings 279
 with adapter sleeves 1270–1272
 with withdrawal sleeves 1276
oil jet 264
 drag losses 112
 oil change interval 267
oil lubrication 262–269
 contamination levels 74–79
 drag losses 110–112
 effect on reference speed 120
 filter rating 75
 methods 262–264
 oil change intervals 267
 oils 265–266
oil mist 264
oil pick-up rings 263
oil supply ducts
 dimensions 211
 in adapter sleeves 1270–1272
 in withdrawal sleeves 1276
 oil injection method (dismounting) 285, 287–290
 oil injection method (mounting) 279
oil-air 254, 264, 267
oils 265–266
oil-spot → oil-air
open bearings
 heating 276
 shelf life 291
open flames 156
operating clearance 149–150, 212
operating preload 212
operating temperature
 effect of grease volume 242
 effect on bearing life 82
 effect on relubrication interval 252–253
 effect on viscosity 71
Orpheus 93
oscillating movements
 and bearings with Solid Oil 1186
 and hybrid bearings 1220
 and NoWear coated bearings 1245
 and SKF DryLube bearings 1192, 1200
 load conditions 165
 sealing solutions 226
 speed considerations 127
 using the static load rating 64, 70, 87
osculation 296, 298
outer ring raceways 25
outer ring rotation
 effect on relubrication interval 253
 fits and tolerance classes 174
 load conditions 166

 with roller encoder units 1162
outer ring shoulder surface 24
outer ring side faces 24
outer rings 24
out-of-round 168
outside diameter 40
 tolerance definitions 134
ovens 1193, 1201
ozone 156

P

P
angular contact ball bearings 480, 504
cylindrical roller bearings 582, 602
INSOCOAT bearings 1208
lock nuts and locking devices 1289
polymer ball bearings 1260
P5
angular contact ball bearings 505
cylindrical roller thrust bearings 1047
deep groove ball bearings 321
needle roller bearings 721
spherical roller bearings 903
tapered roller bearings 823
thrust ball bearings 1015
P52 321
P6
angular contact ball bearings 505
deep groove ball bearings 321
needle roller bearings 721
spherical roller bearings 903
thrust ball bearings 1015
P62
angular contact ball bearings 505
deep groove ball bearings 321
needle roller bearings 721
spherical roller bearings 903
P63
angular contact ball bearings 505
deep groove ball bearings 321
needle roller bearings 721
P64 505
P6CNR 721
PA 582, 602
PA46 → polyamide 46 (PA46)
PA66 → polyamide 66 (PA66)
paired mounting
 with angular contact ball bearings 477–478, 494, 497
 with cylindrical roller bearings 581
 with deep groove ball bearings 309, 318
 with tapered roller bearings 802–803, 814–815, 866–877
paper machines
 and CARB toroidal roller bearings 958, 960, 971
 and NoWear coated bearings 1243
 and SKF DryLube bearings 1193
particle counting 74–76, 78
PEEK → polyetheretherketone (PEEK)
perfluoro polyether (PFPE) 1194–1195
performance classes
 SKF Energy Efficient (E2) bearings 54
 SKF Explorer bearings 63
permissible speed
 of angular contact ball bearings 497
 of CARB toroidal roller bearings 973
 of cylindrical roller bearings 600
 of cylindrical roller thrust bearings 1045
 of deep groove ball bearings 318
 of hybrid bearings 1228
 of INSOCOAT bearings 1210
 of needle roller bearings 714
 of needle roller thrust bearings 1067
 of NoWear coated bearings 1245
 of polymer ball bearings 1258

Note: Designation prefixes and suffixes are shown in **bold**.

Text index

- of self-aligning ball bearings 545
 - of sensor bearing units 1157
 - of spherical roller bearings 896
 - of spherical roller thrust bearings 1084
 - of tapered roller bearings 816
 - of thrust ball bearings 1014
 - of Y-bearings 446
 - PEX**
 - cylindrical roller bearings 583, 603
 - tapered roller bearings 804, 823
 - PH**
 - angular contact ball bearings 480, 504
 - cylindrical roller bearings 582, 602
 - PHA** 582, 602
 - pharmaceutical industry
 - and bearings with Solid Oil 1186
 - and polymer ball bearings 1248
 - PHAS** 481, 504
 - phenolic resin 155
 - phosphate coating
 - on bearings for extreme temperatures 1171–1172
 - on SKF DryLube bearings 1193–1194
 - on sleeves 1270, 1276
 - photographic industry 1248
 - pick-up rings → oil pick-up rings
 - pinions
 - and tapered roller bearings 800
 - preload considerations 219–223
 - pins 1120
 - pitch circle diameter 25
 - plug-and-play
 - roller encoder units 1162
 - sensor units for off-highway vehicles 1165
 - steering encoder units 1163–1164
 - plugs 1108–1109, 1122
 - polyalkylene 1171
 - polyamide 46 (PA46) 155
 - polyamide 66 (PA66)
 - in polymer ball bearings 1250–1251, 1260
 - material properties 153–154
 - polyetheretherketone (PEEK)
 - in polymer ball bearings 1251, 1260
 - material properties 155
 - polyethylene (PE) 1251, 1260
 - polyethylene terephthalate (PET) 1251, 1260
 - polyimide (PI) 1251, 1260
 - polymer ball bearings 1247–1267
 - applications 1248
 - assortment 1248
 - cages 1249, 1250
 - compared to steel bearings 1248, 1252
 - designation system 1260
 - designs and variants 1248–1251
 - dimension standards 1252
 - dimensional stability 1248
 - fits 1259
 - internal clearance 1252–1253
 - loads 1254–1256
 - materials 1250–1251, 1260
 - permissible speed 1258
 - properties 1248
 - temperature limits 1256–1257
 - thermal expansion 1256
 - tolerances 1252–1253
 - polymer bands 886
 - polymer cages 38–39, 153–155
 - polymers
 - in cages 153–155
 - in polymer ball bearings 1250–1251, 1260
 - polyoxymethylene (POM) 1250–1251, 1260
 - polyoxymethylene sooted (POM sooted) 1251, 1260
 - polyphenylsulfide (PPS) 1251, 1260
 - polypropylene (PP) 1250–1251, 1260
 - polytetrafluoroethylene (PTFE) 156
 - polyurea 244, 246, 248, 249
 - polyurethane (PUR) 157
 - polyvinylidene fluoride (PVDF) 1251, 1260
 - pour point 265
 - power loss 114
 - PPA** 1102, 1105–1106, 1125
 - PPSKA** 1106, 1125
 - PPXA** 1125
 - precision 53
 - precision lock nuts
 - designs 1281–1282
 - dimension standards 1285
 - installation and removal 1286–1287
 - loosening torque 1285
 - mating shaft threads 1285
 - product tables 1336–1340
 - tolerances 1285
 - prefixes 45
 - preload
 - adjustment during mounting 218–224
 - benefits 217
 - selection 212–225
 - values for angular contact ball bearings 489
 - versus clearance 212–213
 - with springs 224–225
 - preservatives
 - compatibility with greases 249
 - on new bearings 273, 291
 - presses 275
 - pressure 228
 - pressure centres
 - in angular contact ball bearings 216, 495
 - in tapered roller bearings 216, 812–814
 - pressure-viscosity coefficient 265
 - PTFE → polytetrafluoroethylene (PTFE)
 - pullers 285, 287
 - pulling plates 287
 - pull-up resistors
 - in motor encoder units 1155
 - in steering encoder units 1164
 - pumps
 - fits and tolerance classes 172–175
 - specification life 83
 - PUR → polyurethane (PUR)
- ## Q
- Q**
 - polymer ball bearings 1260
 - tapered roller bearings 800–801, 823
 - QCL7C** 800–801
 - QR** 581, 603
 - quiet running
 - considerations when selecting bearings 54
 - hybrid bearings 1227
 - polymer ball bearings 1248
 - SKF Quiet Running deep groove ball bearings 309
- ## R
- R**
 - cylindrical roller bearings 602
 - deep groove ball bearings 320
 - needle roller bearings 720
 - polymer ball bearings 1260
 - tapered roller bearings 801, 822
 - track runner bearings 1124
 - raceways 25
 - on shafts and in housings 210
 - radial bearings
 - terminology 24–25
 - types 26–33
 - radial internal clearance 149–150
 - values for bearings for extreme temperatures 1174

Note: Designation prefixes and suffixes are shown in **bold**.

- values for CARB toroidal roller bearings 966–967
- values for cylindrical roller bearings 590
- values for deep groove ball bearings 314–315
- values for needle roller bearings 710
- values for polymer ball bearings 1253
- values for self-aligning ball bearings 543
- values for spherical roller bearings 892–893
- radial loads 48, 50–51
- radial location 165–204
- radial run-out 200, 202
- radial shaft seals 24, 226–227, 234
- railway applications
 - and cylindrical roller bearings 603
 - fits and tolerance classes 172–173, 175
 - specification life 83
 - suitable cage types 154
- random statistical adjustment 224
- rated viscosity 71
- rating life
 - basic rating life 64
 - requisite rating life 82
 - SKF rating life 64–65
- ready-to-mount 35
- recesses 24–25
 - in capped deep groove ball bearings 300–303
 - in open deep groove ball bearings 296–297
- reference speed 118–126
- reference temperature 71, 73
- refrigerants 150, 154
- reinforced ball sets 320
- reliability 64–65
- relieved fillets → undercuts
- relubrication 252–261
 - continuous 253–254, 258, 261
 - intervals and adjustments 252–257
 - renewal 258, 260
 - replenishment 258–260
- relubrication-free
 - CARB toroidal roller bearings 962
 - cylindrical roller bearings 581
- renewal 258, 260
- replenishment 258–260
- retaining flanges 25
- retaining rings
 - in cylindrical roller bearings 578, 579, 602
 - in deep groove ball bearings 301
- retaining straps 601
- RF** 429, 457
- ribbon-type cages 37
- rigid bearings 52
- ring gauges 273
 - for needle roller bearings 707
- rings 24
 - materials 151–152
- riveted cages 37–38
- road rollers 888
- roller bearings
 - compared to ball bearings 48, 54
 - designation system 43
- roller encoder units 1162
- rolling element and cage assemblies 25
- rolling elements 24
 - materials 151–152
- rolling frictional moment 100–102, 104–108
- rolling mills → mills
- rolls (metals industry) 1193, 1201
- rope sheaves
 - and cylindrical roller bearings 580
 - fits and tolerance classes 172–174
- rotating discs 232–233
- rotating loads 86, 165–166, 172–175
- rotational speeds → speeds
- roughness → surface roughness
- RS**
 - needle roller bearings 696–697, 720
 - track runner bearings 1101, 1103, 1107, 1125

- RS1**
 - angular contact ball bearings 482, 504
 - bearings with Solid Oil 1189
 - deep groove ball bearings 300, 303, 320
 - self-aligning ball bearings 540, 550
 - Y-bearings 430, 457
- RS2** 303, 320
- RSH**
 - bearings with Solid Oil 1189
 - deep groove ball bearings 300, 303, 320
- RSH2** 1228
- RSL** 300, 302, 320
- running accuracy
 - considerations when selecting fits 167
 - of bearings 132–135, 137–144
 - of seats and abutments 200–203
- running surfaces 1100, 1114–1115
- running-in
 - effect on frictional moment 113
 - of tapered roller bearings 799, 800
 - with grease lubrication 242
- run-out
 - of bearings 135, 137–144
 - of raceways on shafts and in housings 210
 - of seats and abutments 200–202
- RZ** 300–301, 320

S

- S**
 - needle roller bearings 721
 - polymer ball bearings 1260
- S0**
 - deep groove ball bearings 321
 - hybrid bearings 1228
 - needle roller bearings 721
- S1**
 - angular contact ball bearings 505
 - cylindrical roller bearings 603
 - deep groove ball bearings 321
 - needle roller bearings 721
 - SKF DryLube bearings 1203
- S2**
 - cylindrical roller bearings 603
 - motor encoder units 1161
 - needle roller bearings 721
 - SKF DryLube bearings 1203
- S3**
 - needle roller bearings 721
 - SKF DryLube bearings 1203
- salt solutions 1251
- SB** 456
- screw down bearings 35
- seal counterfaces 228
 - accuracy requirements 234–236
- sealed bearings
 - heating 276
 - shelf life 291
 - suitable adapter sleeves 1273
 - suitable lock nuts 1280
 - washing 58, 273
- sealing solutions 226–236
 - calculating the frictional moment 109
 - external seals 231–236
 - integral seals and shields 58–59, 229–230
 - materials 155–157, 230
 - selection criteria 227
- sealing washers 232–233
- season cracking 152
- seat washers 25, 1010–1011, 1014
- seating rings
 - for needle roller bearings 683, 714
 - for Y-bearings 436–437
- segmented cages 1171

Note: Designation prefixes and suffixes are shown in **bold**.

Text index

- selection criteria 22, 46–59
- self-lubricating 1248
- self-aligning ball bearings 537–565
 - axial location 1280
 - cages 540–541, 545
 - clearance reduction 548
 - design provisions 546–549
 - designs and variants 538–541
 - dimension standards 542
 - dimensional stability 545
 - drive-up data 549
 - housings 547
 - internal clearance 542–543
 - kits 547
 - loads 544
 - lock nut tightening angles 549
 - lubrication 540–541, 545
 - misalignment 542–543
 - mounting 276, 540, 548–549
 - on a withdrawal sleeve 546
 - on an adapter sleeve 546–547, 564–565, 1273, 1280
 - permissible speed 545
 - product tables 552–565
 - sealing solutions 538, 540–541, 545, 560–561
 - temperature limits 545
 - tolerances 542–543
 - with an extended inner ring 538, 540, 562–563
 - with protruding balls 539
 - with Solid Oil 1185–1189
- self-aligning bearing systems 162
- self-aligning bearings 52
 - CARB toroidal roller bearings 957–1007
 - self-aligning ball bearings 537–565
 - spherical roller bearings 879–955
- sensor bearing units 1151–1167
 - for electric vehicles 1165
 - for hybrid vehicles 1165
 - for off-highway vehicles 1165
 - motor encoder units 1152–1161
 - roller encoder units 1162
 - steering encoder units 1163–1164
- SensorMount 283
- separable bearings
 - dismounting 285
 - mounting 276
- service life 64
- set screws → grub screws
- shaft abutment shoulders 24
- shaft deflection 52
- shaft diameter 24
- shaft guidance 217
- shaft seats 24, 171
- shaft washers 25
 - in cylindrical roller thrust bearings 1038–1039, 1042, 1045, 1046
 - in needle roller thrust bearings 1060–1061, 1068
 - in spherical roller thrust bearings 1078–1079, 1084
 - in thrust ball bearings 1010–1011, 1014
- shafts 24
 - fits and tolerance classes 172–174, 176–177
 - resultant fits 178–189
- sheet metal cages 37, 152
- shelf life 291
- shields → integral bearing shields
- shock loads 84
 - effect on relubrication interval 253
 - fits and tolerance classes 172–174
 - load conditions 165
 - using the static load rating 87, 89
- silicon nitride (Si₃N₄)
 - compared to bearing steel 152
 - effect on frictional moment 113
 - for bearing rings and rolling elements 152
 - in hybrid bearings 1220–1221
 - in polymer ball bearings 1251, 1260
 - lubrication conditions 241
- sine bars 273
- sine wave control 1165
- single direction bearings
 - cylindrical roller thrust bearings 1038
 - thrust ball bearings 1010–1011, 1014
- single row angular contact ball bearings 476–478, 506–521
- single row cam rollers 1100, 1126–1127
- single row cylindrical roller bearings 570–578, 604–655
- single row deep groove ball bearings 296–297, 322–415
- single row tapered roller bearings → tapered roller bearings
- size categories 275, 285
- SKF bearing beacon 93
- SKF ConCentra Y-bearings
 - designs and variants 422–423, 426, 435
 - mounting 451, 454, 455
 - product tables 468–469
- SKF Drive-up Method 282
 - for CARB toroidal roller bearings 976
 - for spherical roller bearings 900
- SKF DryLube bearings 1191–1203
 - applications 1192–1193
 - assortment 1193
 - cages 1193
 - designation system 1203
 - designs and variants 1194–1195
 - dimension standards 1196–1197
 - dimensional stability 1196–1197, 1203
 - filling grade 1196–1197
 - fits 1202
 - internal clearance 1196–1199
 - limiting speed 1195, 1202
 - loads 1200
 - lubrication 1194–1195, 1203
 - misalignment 1196–1197
 - mounting 1202
 - noise and vibration levels 1192
 - temperature factor 1200–1201
 - temperature limits 1195, 1201
 - tolerances 1196–1197
- SKF Energy Efficient (E2) bearings
 - angular contact ball bearings 485
 - cylindrical roller bearings 583
 - deep groove ball bearings 310
 - frictional moment 54, 113
 - spherical roller bearings 883, 889
 - tapered roller bearings 799, 804
 - Y-bearings 438
- SKF Engineering Consultancy Services 94
- SKF Explorer bearings
 - angular contact ball bearings 485
 - CARB toroidal roller bearings 963
 - cylindrical roller bearings 583
 - deep groove ball bearings 310
 - hybrid bearings 1223
 - load ratings 63
 - spherical roller bearings 889
 - spherical roller thrust bearings 1079
 - tapered roller bearings 799, 804
- SKF greases 249
 - selection chart 250–251
 - temperature ranges 247
- SKF Quiet Running deep groove ball bearings 309
- SKF rating life 64–65
 - calculation examples 90–92
- SKF traffic light concept 244–247
- SKF WAVE seals 230, 304
- skidding 1227
- sleeve mounting
 - accuracy requirements 200–201
 - axial location 207
 - radial location 169
- sleeves
 - adapter sleeves 1270–1274, 1290–1309
 - withdrawal sleeves 1275–1277, 1310–1315
- slewing bearings 45
- sliding frictional moment 103–108

Note: Designation prefixes and suffixes are shown in **bold**.

SM 721
 small bearings 275, 285
 smearing
 in hybrid bearings 241, 1221, 1227
 in NoWear bearings 1242, 1245
 snap ring grooves 24
 in angular contact ball bearings 479, 488, 504
 in cylindrical roller bearings 573, 580, 602
 in deep groove ball bearings 308
 snap rings 24
 in angular contact ball bearings 479, 488, 504
 in cylindrical roller bearings 573, 580, 602
 in deep groove ball bearings 308
 load conditions 206
 snap-type cages 37–38
 solid additives 248, 254
 Solid Oil 1186
Solid Oil (bearings) 1185–1189
 applications 1186–1187
 cages 1189
 designation system 1189
 designs and variants 1186–1187
 dimension standards 1188
 internal clearance 1188
 loads 1188
 lubrication 1186–1187
 mounting 1188
 sealing solutions 1187, 1189
 speed limits 1189
 temperature limits 1187, 1188
 tolerances 1188
 solvents
 effect on cage materials 153
 effect on seal materials 157
SORT 721
 spacer rings 1270
 spalling 63
 in hybrid bearings 1220
 in NoWear bearings 1243
 specific strength 1248
 specification life 82–83
 speed factor
 calculation 246, 253
 limits for grease lubricated bearings 243, 254, 257, 261
 limits for bearings with Solid Oil 1189
 speed limits → permissible speed
 speeds 117–129
 above reference speed 125–126
 considerations when selecting bearings 39, 53
 effect of load 120–125
 effect of oil viscosity 120–125
 effect of temperature 125–126
 effect on relubrication interval 254
 for service life 125
 limiting factors 125–126
 limiting speed 118, 126
 oscillating movements 127
 ranges for grease lubricated bearings 243
 reference speed 118–126
 slow speeds 127
 sphered housings 52
 spherical roller bearings 879–955
 abutment dimensions 898
 applications 882
 assortment 882
 axial displacement 55
 axial location 1280
 bearing arrangements 162, 164
 cages 881, 882–883
 clearance reduction 901
 design provisions 897–901
 designation system 902–903
 designs and variants 33, 880–888
 dimension standards 890
 dimensional stability 896
 drive-up data 901
 for vibratory applications 887–888
 grease life 885
 housings 899
 in vertical shaft arrangements 900
 internal clearance 890–893
 loads 50, 881, 889, 894–895
 lubrication 884–886, 889, 896
 measuring the inner ring expansion 283
 misalignment 52, 890–891, 895
 mounting 884, 886, 900–901
 NoWear coated bearings 1244
 on a withdrawal sleeve 898–899, 946–952
 on an adapter sleeve 898–899, 940–945, 954–955, 1273
 performance classes 889
 permissible speed 885, 896
 product tables 904–955
 sealing solutions 884–886, 896, 898, 928–935
 SKF DryLube bearings 1191–1203
 SKF Energy Efficient (E2) bearings 883, 889
 SKF Explorer bearings 889, 891
 temperature limits 885, 889, 896
 tolerances 890–891
 with a coated bore 887
 with eye bolts 903
 with Solid Oil 1185–1189
 spherical roller thrust bearings 1077–1097
 abutment dimensions 1085
 axial clearance 1086
 cages 1078–1079, 1085, 1088
 design provisions 1085–1086
 designation system 1089
 designs and variants 34, 1078–1079
 dimension standards 1080
 dimensional stability 1084
 in vertical shaft arrangements 1080, 1086–1087
 loads 49, 1082–1084
 lubrication 1086–1087
 misalignment 1078, 1080–1081
 mounting 1088
 NoWear coated bearings 1244
 performance classes 1079
 permissible speed 1084
 product table 1090–1097
 pumping effect 1086
 SKF DryLube bearings 1191–1203
 SKF Explorer bearings 1079
 temperature limits 1084
 tolerances 1080
 spinning 1176
 split inner rings → two-piece inner rings
 spring curves 220
 spring loading 214, 224–225
 spring washers
 for cam followers 1122
 for hybrid bearings 1227
 stabilization → heat stabilization
 stainless steel bearings
 deep groove ball bearings 296–297, 386–409
 fits and tolerance classes 170
 polymer ball bearings 1250–1251, 1260
 Y-bearings 424–425, 434
 stainless steel seals 424, 429
 stainless steel shafts 170
 stainless steels 151, 152
 stamped metal cages 37, 39, 152
 starting torque 114
 start-ups
 effect on frictional moment 99
 temperature differences 167, 214
 test running 284
 static load carrying capacity 87–89, 91
 static load rating 64
 static safety factor 64, 88–89
 calculation example 91–92
 static seals 226
 stationary bearings 64, 87

Note: Designation prefixes and suffixes are shown in **bold**.

Text index

- stationary loads 165–166, 172–175
 - steels
 - cage material properties 152–153
 - compared to silicon nitride 152
 - for rings and rolling elements 151
 - steer-by-wire 1163, 1165
 - steering encoder units 1163–1164
 - stepped sleeves 206
 - stiffness
 - considerations when selecting bearings 54
 - effect of a loose fit 167
 - effect of preload 217, 219, 225
 - of hybrid bearings 1220
 - of roller bearings compared to ball bearings 54
 - storage 291
 - straightness 203
 - stray capacitance 1206
 - studs 1104–1109
 - suffixes 44–45
 - super-precision bearings 28, 34, 53, 1222
 - support rollers 1101–1104, 1130–1139
 - axial gap 1121
 - cages 1111, 1119
 - designation system 1124–1125
 - designs and variants 1100–1104
 - internal clearance 1114–1115
 - mounting 1101, 1122
 - product tables 1130–1139
 - sealing solutions 1101–1104, 1119, 1130–1139
 - support surfaces 1102, 1120–1121
 - temperature limits 1119
 - tolerances 1114–1115, 1118
 - with flange rings 1102–1104, 1134–1139
 - support washers 1175
 - surface roughness
 - of bearing seats 204
 - of raceways on shafts and in housings 210
 - of seal counterfaces 234–236
 - synthetic oils 265
 - effect on cage materials 152–154
 - in capped deep groove ball bearings 305
 - in grease 249
 - in Solid Oil 1186–1187
 - SYSTEM 24 261
 - SYSTEM MultiPoint 261
- ## T
- lock nuts and locking devices 1289
 - polymer ball bearings 1260
 - tapered roller bearings 820, 822
 - tandem arrangements
 - with angular contact ball bearings 478, 495
 - with deep groove ball bearings 309
 - with tapered roller bearings 802–803, 876–877
 - taper gauges 273
 - tapered bores
 - axial location 207
 - radial location 169
 - radial preloading 221
 - tapered roller bearings 797–877
 - adjustment during mounting 221–225, 277
 - assortment 800
 - axial load carrying capacity 798, 812–813
 - bearing arrangements 161, 163
 - cages 803, 816
 - contact angle 798, 820, 822
 - design provisions 816–819
 - designation system 820–821, 822–823
 - designs and variants 32, 798–803
 - dimension standards 806–808
 - dimensional stability 816
 - double row bearings 800
 - fits and tolerance classes 816–819
 - four-row bearings 800
 - friction 798–800, 804, 816
 - heat treatment 822
 - inch bearings 816, 818–819, 821, 842–863
 - internal clearance 806–808, 810
 - loads 49–51, 811
 - matched bearings 802–803, 814–815, 866–877
 - misalignment 798, 802, 806–808, 823
 - mounting 817
 - performance classes 804
 - permissible speed 816
 - preload 215–220, 806–807, 816
 - product tables 824–877
 - running-in 799, 800
 - SKF DryLube bearings 1191–1203
 - SKF Energy Efficient (E2) bearings 799, 804
 - SKF Explorer bearings 799, 804
 - temperature limits 816
 - tolerances 806–809
 - TQ-line bearings 799, 800–801
 - with a flanged outer ring 801, 864–865
 - with Solid Oil 1185–1189
 - tapered roller thrust bearings 35
 - tapered shaft seats
 - axial location 207
 - radial location 169
 - tolerances 202–203
 - temperature
 - increase during operation 114
 - ranges for grease lubricated bearings 243, 244–247
 - temperature difference
 - considerations when selecting fits 167
 - resulting clearance reduction 214
 - temperature zones 246–247
 - terminology 23–25
 - test running 284
 - testing 95
 - textile industry 1248
 - thermal contraction 971
 - thermal displacements 160
 - thermal expansion
 - considerations when selecting fits 167
 - fits and tolerance classes 175
 - with CARB toroidal roller bearings 958, 971, 974
 - thin section bearings 45
 - threaded holes 210–211
 - threads
 - for adapter sleeves 1274
 - for lock nuts 1284–1285
 - for withdrawal sleeves 1277
 - through-hardening steels 151
 - thrust ball bearings 1009–1035
 - ball and cage assemblies 1010
 - cages 1010–1011, 1014
 - combined with a needle roller bearing 685–688, 784–787
 - designation system 1015
 - designs and variants 1010–1011
 - dimension standards 1012
 - dimensional stability 1014
 - double direction bearings 1010–1011, 1030–1035
 - loads 1010, 1013
 - misalignment 1012
 - mounting 1014
 - NoWear coated bearings 1244
 - permissible speed 1014
 - polymer ball bearings 1247–1261, 1266–1267
 - product tables 1016–1035
 - single direction bearings 1010–1011
 - SKF DryLube bearings 1191–1203
 - temperature limits 1014
 - tolerances 1012
 - washers 1010–1011, 1014
 - with sphered housing washers 1011
 - thrust bearings
 - fits and tolerance classes 174–175

Note: Designation prefixes and suffixes are shown in **bold**.

terminology 25
types 33–35
thrust collars → angle rings
tight fits → interference fits
tilting moments 51
with angular contact ball bearings 478
with tapered roller bearings 802
titanium 1251, 1260
TL 1273, 1289
TN
cylindrical roller thrust bearings 1040, 1047
needle roller bearings 695, 720
needle roller thrust bearings 1062, 1069
self-aligning ball bearings 550
track runner bearings 1111, 1125
TN9
angular contact ball bearings 481, 504
CARB toroidal roller bearings 961, 978
deep groove ball bearings 299, 320
self-aligning ball bearings 541, 550
tapered roller bearings 803, 822
TNH
deep groove ball bearings 299, 320
tapered roller bearings 803, 822
tolerance classes 169–170
tolerance grades 201
tolerances 132–148
definitions 134–135
for housings 190–199
for radial bearings 137–144
for shafts 178–189
for shafts (sleeve mounting) 201
for shafts (tapered seats) 202–203
for tapered bores 145–146
for thrust bearings 144
toroidal roller bearings → CARB toroidal roller bearings
torque
starting torque 114
tightening torques for Y-bearings 452, 454
torque indicators 451
TQ-line bearings 799, 800–801
TR 581, 603
track runner bearings 1099–1147
cages 1111, 1119
cam followers 1104–1110, 1140–1147
cam rollers 1100, 1126–1129
design provisions 1120–1121
designation system 1124–1125
designs and variants 35–36, 1100–1113
dimension standards 1114–1115
dimensional stability 1119
internal clearance 1114–1115
loads 1116–1117
lubrication 1112–1113, 1119
product tables 1126–1147
running surfaces 1100, 1114–1115
sealing solutions 1100–1107, 1119
speed limits 1112, 1119
support rollers 1101–1104, 1130–1139
support surfaces 1102, 1120–1121
temperature limits 1119
tolerances 1114–1115, 1118
traction motors
and hybrid bearings 1224
fits and tolerance classes 172–174
traffic light concept → SKF traffic light concept
transition fits 170
turbines 172–173
two-piece inner rings
in double row angular contact ball bearings 479
in four-point contact ball bearings 480

U

U
sensor bearing units 1161
tapered roller bearings 823
Y-bearings 457
unbalance 84, 86, 165
undercuts 208
unit conversion table 8
for bearing life 70
units → bearing units
universal washers
in cylindrical roller thrust bearings 1039, 1042
in needle roller thrust bearings 1060–1061, 1064, 1068
universally matchable bearings
adjustment 498
assortment 500
axial internal clearance values 488
design 477
preload values 489
unthreaded sleeves 1288

V

V
CARB toroidal roller bearings 961, 978
cylindrical roller bearings 602
polymer ball bearings 1260
V001 823
VA201 1171–1172, 1176
VA208 1171–1172, 1175, 1176
VA210 1195, 1202, 1203
VA2101 1195, 1202, 1203
VA228 1171–1172, 1175, 1176
VA237 1195, 1202, 1203
VA260 1195, 1202, 1203
VA261 1195, 1202, 1203
VA267 1195, 1202, 1203
VA301 603
VA305 603
VA3091 603
VA321 823
VA350 603
VA380 603
VA405 887, 903
VA406 887, 903
VA606 823
VA607 823
VA970 1223, 1228
vacuum applications
and hybrid bearings 1225
and NoWear coated bearings 1243
and polymer ball bearings 1248
variable loads 81, 165
VB022 823
VB026 823
VB061 823
VB134 823
VB406 823
VB481 823
VC025 603
VC027 823
VC068 823
VE174 823
VE240 978
VE447(E) 1089
VE495 424, 457
VE552(E) 903
VE553(E) 903
VE632 1089
vertical shaft arrangements
considerations when selecting a grease 246
drag losses 112

Note: Designation prefixes and suffixes are shown in **bold**.

Text index

- effect on relubrication interval 253
 - with bearings with Solid Oil 1186
 - with CARB toroidal roller bearings 976
 - with four-point contact ball bearings 499
 - with spherical roller bearings 900
 - with spherical roller thrust bearings 1080, 1086–1087
 - VG052** 721
 - VG114**
 - CARB toroidal roller bearings 963, 978
 - spherical roller bearings 903
 - VG1561** 299, 320
 - VGS** 692, 720
 - VH** 602
 - vibrating screens 888
 - vibration
 - cage guidance 39
 - effect on grease consistency 246
 - effect on relubrication interval 253
 - generation at high speeds 128
 - load conditions 165–166
 - protection using preload 225
 - with CARB toroidal roller bearings 958, 963
 - with hybrid bearings 1220, 1223
 - with NoWear coated bearings 1245
 - with spherical roller bearings 887–888
 - with Y-bearings 436
 - virtual testing 93, 94
 - viscosity 71–73
 - of grease 246
 - of oil 266–269
 - viscosity grades 71
 - viscosity index 71, 265–266
 - viscosity ratio
 - calculation example 91
 - in bearing life calculations 71–73
 - lubrication conditions 241
 - VL0241** 1207, 1211
 - VL065** 457
 - VL2071** 1207, 1211
 - VP076** 431, 457
 - VQ015** 603
 - VQ051** 823
 - VQ267** 823
 - VQ424** 903
 - VQ495** 823
 - VQ506** 823
 - VQ507** 823
 - VQ523** 823
 - VQ601** 823
 - VQ658** 309, 321
 - V-ring seals 235
 - VT113** 483, 505
 - VT143** 885, 903
 - VT143B** 903
 - VT143C** 903
 - VT378** 304–306, 321
- W**
- W**
 - bearings for extreme temperatures 1176
 - deep groove ball bearings 320
 - polymer ball bearings 1260
 - spherical roller bearings 903
 - tapered roller bearings 823
 - Y-bearings 457
 - W20** 883, 903
 - W26** 903
 - W33** 883, 903
 - W33X** 903
 - W513** 903
 - W64**
 - bearings with Solid Oil 1186–1187, 1189
 - self-aligning ball bearings 550
 - spherical roller bearings 903
 - W64F** 1186–1187, 1189
 - W64H** 1187, 1189
 - W64L** 1187, 1189
 - W77** 903
 - washers
 - in cylindrical roller thrust bearings 1038–1039, 1042, 1045, 1046
 - in needle roller thrust bearings 1060–1061, 1064, 1067, 1068
 - in spherical roller thrust bearings 1078–1079, 1084
 - washing
 - capped bearings 58, 273
 - new bearings 272–273
 - washout 248
 - water
 - protection with deep groove ball bearings 300
 - protection with grease 248, 253
 - protection with INSOCOAT bearings 1206
 - WAVE** seals → SKF WAVE seals
 - wear
 - effect of preload 217
 - in non-contact seals 226, 228
 - load conditions 165
 - resistance with NoWear coated bearings 1242, 1245
 - wheel bearings
 - fits and tolerance classes 172–174
 - load conditions 166
 - white mineral spirits 273, 291
 - width 40
 - tolerance definitions 135
 - width series 40–41
 - wind energy applications
 - and tapered roller bearings 804
 - and XL hybrid bearings 1223
 - fits and tolerance classes 172
 - specification life 83
 - window-type cages 37–38
 - withdrawal sleeves 1275–1277, 1310–1315
 - axial location 207
 - bearing seat tolerances 200–201
 - coatings 1276
 - designation system 1288–1289
 - dimension standards 1277
 - dismounting bearings 290
 - for CARB toroidal roller bearings 975, 1004–1007
 - for oil injection 1276
 - for self-aligning ball bearings 546
 - for spherical roller bearings 898–899, 946–952
 - mounting bearings 278–279
 - product tables 1310–1315
 - tapers 1277
 - threads 1277
 - tolerances 1277
 - wood-working machines 172–173
 - wrist pins → gudgeon pins
- WS**
- cylindrical roller thrust bearings 1039, 1042, 1047
 - needle roller thrust bearings 1061, 1068, 1069
- WT**
- angular contact ball bearings 483, 505
 - deep groove ball bearings 304–305, 321
 - hybrid bearings 1223
- X**
- X**
 - deep groove ball bearings 320
 - polymer ball bearings 1260
 - tapered roller bearings 822
 - track runner bearings 1125
 - XA** 1125
 - XL hybrid bearings
 - assortment 1222

Note: Designation prefixes and suffixes are shown in **bold**.

design 1223
dimensional stability 1228
product table 1236–1237

Z5 300–301, 320
ZW 675, 720

Y

Y 480, 504
Y-bearing units 422
 for extreme temperatures 1170
 misalignment 52
 with Solid Oil 1185–1189
Y-bearings 421–472
 applications 422, 435
 assortment 422
 axial displacement 447–448
 axial load carrying capacity 444
 cages 428, 446
 design provisions 447–450
 designs and variants 27, 422–438
 dimension standards 440–441
 dimensional stability 446
 dismounting 451–455
 fits and tolerance classes 450–451
 for agricultural applications 430, 434, 435, 446–447
 for extreme temperatures 1170–1176, 1182–1183
 for inch shafts 460–462, 466–467, 469, 471
 for the food industry 424–425, 431
 grease life 432–433
 internal clearance 440–442
 loads 444–445
 lubrication 431–434, 446
 misalignment 440–441
 mounting 451–455
 on an adapter sleeve 422–423, 427, 470–471
 performance classes 438
 permissible speed 446–447
 product tables 458–472
 sealing solutions 429–434, 446, 458–472
 SKF ConCentra bearings 422–423, 426, 435, 468–469
 SKF DryLube bearings 1191–1203
 stainless steel bearings 424–425, 434
 temperature limits 446
 tightening torques 452, 454
 tolerances 440–442
 with a standard inner ring 422–423, 428, 472
 with a tapered bore 427, 470–471
 with a zinc coating 424–425, 431, 434, 435
 with an eccentric locking collar 422–423, 425, 435, 464–467
 with an extended inner ring 422, 424–427
 with an interference fit 422–423, 428
 with grub screws 422–423, 424–425, 448, 458–462
 with seating rings 436–437
 with Solid Oil 1185–1189

Z

Z
 angular contact ball bearings 482, 504
 bearings for extreme temperatures 1171–1172, 1175, 1176
 bearings with Solid Oil 1189
 deep groove ball bearings 300–301, 320
 needle roller bearings 687–689, 696, 698–699, 720
 polymer ball bearings 1260
 track runner bearings 1125

ZE

 CARB toroidal roller bearings 978
 spherical roller bearings 902
 zinc chromate 157
 zinc coating 424–425, 431, 434, 435
 zirconium dioxide (ZrO₂) 1251, 1260

ZL 1104, 1125

ZNR 308, 320

Note: Designation prefixes and suffixes are shown in **bold**.

Product index

Designation	Product	Product table	
		No.	Page ¹⁾
028..	Inch single row tapered roller bearings	7.2	842
03..	Inch single row tapered roller bearings	7.2	842
07..	Inch single row tapered roller bearings	7.2	842
09..	Inch single row tapered roller bearings	7.2	842
10..	Self-aligning ball bearings	4.1	552
11..	Inch single row tapered roller bearings	7.2	842
112..	Self-aligning ball bearings with an extended inner ring	4.3	562
115..	Inch single row tapered roller bearings	7.2	842
12..	Self-aligning ball bearings	4.1	552
13..	Self-aligning ball bearings	4.1	552
130..	Self-aligning ball bearings	4.1	552
14..	Inch single row tapered roller bearings	7.2	842
15..	Inch single row tapered roller bearings	7.2	842
155..	Inch single row tapered roller bearings	7.2	842
160..	Single row deep groove ball bearings	1.1	322
160../HR	Polymer single row deep groove ball bearings	15H.1	1262
161..	Single row deep groove ball bearings	1.1	322
161../H	Polymer single row deep groove ball bearings	15H.1	1262
17262..	Y-bearings with a standard inner ring	2.9	472
17263..	Y-bearings with a standard inner ring	2.9	472
186..	Inch single row tapered roller bearings	7.2	842
19..	Inch single row tapered roller bearings	7.2	842
2..	Single row deep groove ball bearings with filling slots	1.8	410
2..NR	Single row deep groove ball bearings with filling slots and a snap ring	1.9	414
2..-ZZ	Shielded single row deep groove ball bearings with filling slots	1.8	410
2..-ZZNR	Shielded single row deep groove ball bearings with filling slots and a snap ring	1.9	414
2..-Z	Shielded single row deep groove ball bearings with filling slots	1.8	410
2..-ZNR	Shielded single row deep groove ball bearings with filling slots and a snap ring	1.9	414
213..	Spherical roller bearings	8.1	904
22..	Self-aligning ball bearings	4.1	552
22..-2RS1	Sealed self-aligning ball bearings	4.2	560
222..	Spherical roller bearings	8.1	904
222..-2CS5	Sealed spherical roller bearings	8.2	928
223..	Spherical roller bearings	8.1	904
223../VA405	Spherical roller bearings for vibratory applications	8.3	936
223../VA406	Spherical roller bearings for vibratory applications	8.3	936
223..-2CS5	Sealed spherical roller bearings	8.2	928
23..	Self-aligning ball bearings	4.1	552
23..-2RS1	Sealed self-aligning ball bearings	4.2	560
230..	Spherical roller bearings	8.1	904
230..-2CS	Sealed spherical roller bearings	8.2	928
230..-2CS5	Sealed spherical roller bearings	8.2	928
231..	Spherical roller bearings	8.1	904
231..-2CS5	Sealed spherical roller bearings	8.2	928
232..	Spherical roller bearings	8.1	904
232..-2CS	Sealed spherical roller bearings	8.2	928
232..-2CS5	Sealed spherical roller bearings	8.2	928
236..	Inch single row tapered roller bearings	7.2	842
238..	Spherical roller bearings	8.1	904
239..	Spherical roller bearings	8.1	904
239..-2CS	Sealed spherical roller bearings	8.2	928
240..	Spherical roller bearings	8.1	904
240..-2CS2	Sealed spherical roller bearings	8.2	928

¹⁾ Starting page of the product table.

Designation	Product	Product table	
		No.	Page ¹⁾
240..-2CS5	Sealed spherical roller bearings	8.2	928
241..	Spherical roller bearings	8.1	904
241..-2CS5	Sealed spherical roller bearings	8.2	928
247..	Inch single row tapered roller bearings	7.2	842
248..	Spherical roller bearings	8.1	904
249..	Spherical roller bearings	8.1	904
255..	Inch single row tapered roller bearings	7.2	842
258..	Inch single row tapered roller bearings	7.2	842
27..	Inch single row tapered roller bearings	7.2	842
292..	Spherical roller thrust bearings	13.1	1090
293..	Spherical roller thrust bearings	13.1	1090
294..	Spherical roller thrust bearings	13.1	1090
3..	Single row deep groove ball bearings with filling slots	1.8	410
3.. NR	Single row deep groove ball bearings with filling slots and a snap ring	1.9	414
3..-2Z	Shielded single row deep groove ball bearings with filling slots	1.8	410
3..-2ZNR	Shielded single row deep groove ball bearings with filling slots and a snap ring	1.9	414
3..-Z	Shielded single row deep groove ball bearings with filling slots	1.8	410
3..-ZNR	Shielded single row deep groove ball bearings with filling slots and a snap ring	1.9	414
302..	Single row tapered roller bearings	7.1	824
302.. R	Single row tapered roller bearings with a flanged outer ring	7.3	864
302../DB	Single row tapered roller bearings, matched for mounting back-to-back	7.5	872
302../DF	Single row tapered roller bearings, matched for mounting face-to-face	7.4	866
303..	Single row tapered roller bearings	7.1	824
303.. R	Single row tapered roller bearings with a flanged outer ring	7.3	864
303../DB	Single row tapered roller bearings, matched for mounting back-to-back	7.5	872
303../DF	Single row tapered roller bearings, matched for mounting face-to-face	7.4	866
3057.. C	Double row cam rollers	14.2	1128
3058.. C	Double row cam rollers	14.2	1128
313..	Single row tapered roller bearings	7.1	824
313.. X	Single row tapered roller bearings	7.1	824
313.. X/DB	Single row tapered roller bearings, matched for mounting back-to-back	7.5	872
313.. X/DF	Single row tapered roller bearings, matched for mounting face-to-face	7.4	866
313../DB	Single row tapered roller bearings, matched for mounting back-to-back	7.5	872
313../DF	Single row tapered roller bearings, matched for mounting face-to-face	7.4	866
315..	Inch single row tapered roller bearings	7.2	842
3194.. DA-2LS	Sealed double row full complement cylindrical roller bearings	5.5	668
32.. A	Double row angular contact ball bearings	3.2	522
32.. A-2RS1	Sealed double row angular contact ball bearings	3.3	526
32.. A-2Z	Shielded double row angular contact ball bearings	3.3	526
320.. X	Single row tapered roller bearings	7.1	824
320.. X/DB	Single row tapered roller bearings, matched for mounting back-to-back	7.5	872
320.. X/DF	Single row tapered roller bearings, matched for mounting face-to-face	7.4	866
320.. XR	Single row tapered roller bearings with a flanged outer ring	7.3	864
322..	Single row tapered roller bearings	7.1	824
322.. B	Single row tapered roller bearings	7.1	824
322../DB	Single row tapered roller bearings, matched for mounting back-to-back	7.5	872
322../DF	Single row tapered roller bearings, matched for mounting face-to-face	7.4	866
323..	Single row tapered roller bearings	7.1	824
323.. B	Single row tapered roller bearings	7.1	824
323.. BR	Single row tapered roller bearings with a flanged outer ring	7.3	864
329..	Single row tapered roller bearings	7.1	824
329../DB	Single row tapered roller bearings, matched for mounting back-to-back	7.5	872
329../DF	Single row tapered roller bearings, matched for mounting face-to-face	7.4	866
33.. A	Double row angular contact ball bearings	3.2	522
33.. A-2RS1	Sealed double row angular contact ball bearings	3.3	526
33.. A-2Z	Shielded double row angular contact ball bearings	3.3	526
33.. D	Double row angular contact ball bearings with a two-piece inner ring	3.2	522
33.. DNR	Double row angular contact ball bearings with a two-piece inner ring, a snap ring groove and a snap ring in the outer ring	3.2	522
330..	Single row tapered roller bearings	7.1	824
330../DF	Single row tapered roller bearings, matched for mounting face-to-face	7.4	866
331..	Single row tapered roller bearings	7.1	824
331.. R	Single row tapered roller bearings with a flanged outer ring	7.3	864
331../DF	Single row tapered roller bearings, matched for mounting face-to-face	7.4	866
332..	Single row tapered roller bearings	7.1	824
332../QDF	Single row tapered roller bearings, matched for mounting face-to-face	7.4	866
338..	Inch single row tapered roller bearings	7.2	842
34..	Inch single row tapered roller bearings	7.2	842
35..	Inch single row tapered roller bearings	7.2	842
359..	Inch single row tapered roller bearings	7.2	842

¹⁾ Starting page of the product table.

Product index

Designation	Product	Product table	
		No.	Page ¹⁾
3612.. R	Single row cam rollers	14.1	1126
368..	Inch single row tapered roller bearings	7.2	842
369..	Inch single row tapered roller bearings	7.2	842
369..	Inch single row tapered roller bearings	7.2	842
37..	Inch single row tapered roller bearings	7.2	842
370..	Inch single row tapered roller bearings	7.2	842
387..	Inch single row tapered roller bearings	7.2	842
388..	Inch single row tapered roller bearings	7.2	842
39..	Inch single row tapered roller bearings	7.2	842
395..	Inch single row tapered roller bearings	7.2	842
418..	Inch single row tapered roller bearings	7.2	842
42.. A	Double row deep groove ball bearings	1.10	416
426..	Inch single row tapered roller bearings	7.2	842
43.. A	Double row deep groove ball bearings	1.10	416
45..	Inch single row tapered roller bearings	7.2	842
462..	Inch single row tapered roller bearings	7.2	842
474..	Inch single row tapered roller bearings	7.2	842
476..	Inch single row tapered roller bearings	7.2	842
511..	Single direction thrust ball bearings	10.1	1016
511.. V/HR	Polymer full complement thrust ball bearings	15H.2	1266
512..	Single direction thrust ball bearings	10.1	1016
512.. V/HR	Polymer full complement thrust ball bearings	15H.2	1266
513..	Single direction thrust ball bearings	10.1	1016
513.. V/HR	Polymer full complement thrust ball bearings	15H.2	1266
514..	Single direction thrust ball bearings	10.1	1016
522..	Double direction thrust ball bearings	10.3	1030
523..	Double direction thrust ball bearings	10.3	1030
524..	Double direction thrust ball bearings	10.3	1030
528..	Inch single row tapered roller bearings	7.2	842
53..	Inch single row tapered roller bearings	7.2	842
532..	Single direction thrust ball bearings with a sphered housing washer	10.2	1026
533..	Single direction thrust ball bearings with a sphered housing washer	10.2	1026
534..	Single direction thrust ball bearings with a sphered housing washer	10.2	1026
535..	Inch single row tapered roller bearings	7.2	842
539..	Inch single row tapered roller bearings	7.2	842
542..	Double direction thrust ball bearings with sphered housing washers	10.4	1034
543..	Double direction thrust ball bearings with sphered housing washers	10.4	1034
544..	Inch single row tapered roller bearings	7.2	842
544..	Double direction thrust ball bearings with sphered housing washers	10.4	1034
566..	Inch single row tapered roller bearings	7.2	842
567..	Inch single row tapered roller bearings	7.2	842
575..	Inch single row tapered roller bearings	7.2	842
580..	Inch single row tapered roller bearings	7.2	842
594..	Inch single row tapered roller bearings	7.2	842
598..	Inch single row tapered roller bearings	7.2	842
60..	Single row deep groove ball bearings	1.1	322
60.. N	Single row deep groove ball bearings with a snap ring groove	1.4	376
60.. NR	Single row deep groove ball bearings with a snap ring groove and a snap ring	1.4	376
60..HR	Polymer single row deep groove ball bearings	15H.1	1262
60../VA201	Single row deep groove ball bearings for extreme temperatures	15B.1	1178
60..-2RS1	Sealed single row deep groove ball bearings	1.2	346
60..-2RSH	Sealed single row deep groove ball bearings	1.2	346
60..-2RSL	Sealed single row deep groove ball bearings	1.2	346
60..-2RSL/HC5	Sealed hybrid single row deep groove ball bearings	15F.2	1232
60..-2RZ	Sealed single row deep groove ball bearings	1.2	346
60..-2RZ/HC5	Sealed hybrid single row deep groove ball bearings	15F.2	1232
60..-2Z	Shielded single row deep groove ball bearings	1.2	346
60..-2Z/VA201	Shielded single row deep groove ball bearings for extreme temperatures	15B.1	1178
60..-2Z/VA208	Shielded single row deep groove ball bearings for extreme temperatures	15B.1	1178
60..-2ZNR	Shielded single row deep groove ball bearings with a snap ring	1.5	382
60..-RS1	Sealed single row deep groove ball bearings	1.2	346
60..-RSH	Sealed single row deep groove ball bearings	1.2	346
60..-RSL	Sealed single row deep groove ball bearings	1.2	346
60..-RZ	Sealed single row deep groove ball bearings	1.2	346
60..-Z	Shielded single row deep groove ball bearings	1.2	346
60..-ZNR	Shielded single row deep groove ball bearings with a snap ring	1.5	382
618..	Single row deep groove ball bearings	1.1	322
618..-2RS1	Sealed single row deep groove ball bearings	1.2	346

¹⁾ Starting page of the product table.

Designation	Product	Product table	
		No.	Page ¹⁾
618..-2RZ	Sealed single row deep groove ball bearings	1.2	346
619..	Single row deep groove ball bearings	1.1	322
619..-2RS1	Sealed single row deep groove ball bearings	1.2	346
619..-2RZ	Shielded single row deep groove ball bearings	1.2	346
62..	Single row deep groove ball bearings	1.1	322
62.. N	Single row deep groove ball bearings with a snap ring groove	1.4	376
62.. NR	Single row deep groove ball bearings with a snap ring groove and a snap ring	1.4	376
62../C3VL0241	INSOCOAT single row deep groove ball bearings	15E.1	1212
62../C3VL2071	INSOCOAT single row deep groove ball bearings	15E.1	1212
62../HC5	Hybrid single row deep groove ball bearings	15F.1	1230
62../HR	Polymer single row deep groove ball bearings	15H.1	1262
62../VA201	Single row deep groove ball bearings for extreme temperatures	15B.1	1178
62..-2RS1	Sealed single row deep groove ball bearings	1.2	346
62..-2RS1/HC5	Sealed hybrid single row deep groove ball bearings	15F.2	1232
62..-2RSH	Sealed single row deep groove ball bearings	1.2	346
62..-2RSL	Sealed single row deep groove ball bearings	1.2	346
62..-2RSL/HC5	Sealed hybrid single row deep groove ball bearings	15F.2	1232
62..-2RZ	Sealed single row deep groove ball bearings	1.2	346
62..-2RZ/HC5	Sealed hybrid single row deep groove ball bearings	15F.2	1232
62..-2Z	Shielded single row deep groove ball bearings	1.2	346
62..-2Z/VA201	Shielded single row deep groove ball bearings for extreme temperatures	15B.1	1178
62..-2Z/VA208	Shielded single row deep groove ball bearings for extreme temperatures	15B.1	1178
62..-2Z/VA228	Shielded single row deep groove ball bearings for extreme temperatures	15B.1	1178
62..-2ZNR	Shielded single row deep groove ball bearings with a snap ring	1.5	382
62..-RS1	Sealed single row deep groove ball bearings	1.2	346
62..-RSH	Sealed single row deep groove ball bearings	1.2	346
62..-RSL	Sealed single row deep groove ball bearings	1.2	346
62..-RZ	Sealed single row deep groove ball bearings	1.2	346
62..-Z	Shielded single row deep groove ball bearings	1.2	346
62..-ZNR	Shielded single row deep groove ball bearings with a snap ring	1.5	382
63..	Single row deep groove ball bearings	1.1	322
63..	Inch single row tapered roller bearings	7.2	842
63.. N	Single row deep groove ball bearings with a snap ring groove	1.4	376
63.. NR	Single row deep groove ball bearings with a snap ring groove and a snap ring	1.4	376
63../C3VL0241	INSOCOAT single row deep groove ball bearings	15E.1	1212
63../C3VL2071	INSOCOAT single row deep groove ball bearings	15E.1	1212
63../HC5	Hybrid single row deep groove ball bearings	15F.1	1230
63../HC5C3S0VA970	XL hybrid single row deep groove ball bearings	15F.3	1236
63../HR	Polymer single row deep groove ball bearings	15H.1	1262
63../VA201	Single row deep groove ball bearings for extreme temperatures	15B.1	1178
63..-2RS1	Sealed single row deep groove ball bearings	1.2	346
63..-2RS1/HC5	Sealed hybrid single row deep groove ball bearings	15F.2	1232
63..-2RSH	Sealed single row deep groove ball bearings	1.2	346
63..-2RSL	Sealed single row deep groove ball bearings	1.2	346
63..-2RZ	Sealed single row deep groove ball bearings	1.2	346
63..-2Z	Shielded single row deep groove ball bearings	1.2	346
63..-2Z/VA201	Shielded single row deep groove ball bearings for extreme temperatures	15B.1	1178
63..-2Z/VA208	Shielded single row deep groove ball bearings for extreme temperatures	15B.1	1178
63..-2Z/VA228	Shielded single row deep groove ball bearings for extreme temperatures	15B.1	1178
63..-2ZNR	Shielded single row deep groove ball bearings with a snap ring	1.5	382
63..-RS1	Sealed single row deep groove ball bearings	1.2	346
63..-RSH	Sealed single row deep groove ball bearings	1.2	346
63..-RSL	Sealed single row deep groove ball bearings	1.2	346
63..-RZ	Sealed single row deep groove ball bearings	1.2	346
63..-Z	Shielded single row deep groove ball bearings	1.2	346
63..-ZNR	Shielded single row deep groove ball bearings with a snap ring	1.5	382
630..-2RS1	Sealed single row deep groove ball bearings	1.2	346
64..	Single row deep groove ball bearings	1.1	322
64..	Inch single row tapered roller bearings	7.2	842
64.. N	Single row deep groove ball bearings with a snap ring groove	1.4	376
64.. NR	Single row deep groove ball bearings with a snap ring groove and a snap ring	1.4	376
653..	Inch single row tapered roller bearings	7.2	842
673..	Inch single row tapered roller bearings	7.2	842
679..	Inch single row tapered roller bearings	7.2	842
68..	Inch single row tapered roller bearings	7.2	842
683..	Inch single row tapered roller bearings	7.2	842
687..	Inch single row tapered roller bearings	7.2	842

¹⁾ Starting page of the product table.

Product index

Designation	Product	Product table	
		No.	Page ¹⁾
70.. B	Single row angular contact ball bearings	3.1	506
72..	Inch single row tapered roller bearings	7.2	842
72.. B	Single row angular contact ball bearings	3.1	506
73.. B	Single row angular contact ball bearings	3.1	506
811..	Single row cylindrical roller thrust bearings	11.1	1148
812..	Single row cylindrical roller thrust bearings	11.1	1148
87..	Inch single row tapered roller bearings	7.2	842
893..	Double row cylindrical roller thrust bearings	11.1	1148
894..	Double row cylindrical roller thrust bearings	11.1	1148
92..	Inch single row tapered roller bearings	7.2	842
A 4..	Inch single row tapered roller bearings	7.2	842
AH 22..	Withdrawal sleeves	16.4	1310
AH 23..	Withdrawal sleeves	16.4	1310
AH 240..	Withdrawal sleeves	16.4	1310
AH 241..	Withdrawal sleeves	16.4	1310
AH 3..	Withdrawal sleeves	16.4	1310
AH 30..	Withdrawal sleeves	16.4	1310
AH 31..	Withdrawal sleeves	16.4	1310
AH 32..	Withdrawal sleeves	16.4	1310
AHE-5401 C	Steering encoder unit	-	1163
AHE-5509 A	Roller encoder unit	-	1162
AHE-5701 C	Steering encoder unit	-	1163
AHX 23..	Withdrawal sleeves	16.4	1310
AHX 3..	Withdrawal sleeves	16.4	1310
AHX 30..	Withdrawal sleeves	16.4	1310
AHX 31..	Withdrawal sleeves	16.4	1310
AHX 32..	Withdrawal sleeves	16.4	1310
AN ..	Inch lock nuts	16.9	1326
AOH 22..	Withdrawal sleeves for oil injection	16.4	1310
AOH 23..	Withdrawal sleeves for oil injection	16.4	1310
AOH 240..	Withdrawal sleeves for oil injection	16.4	1310
AOH 241..	Withdrawal sleeves for oil injection	16.4	1310
AOH 30..	Withdrawal sleeves for oil injection	16.4	1310
AOH 31..	Withdrawal sleeves for oil injection	16.4	1310
AOH 32..	Withdrawal sleeves for oil injection	16.4	1310
AOHX 241..	Withdrawal sleeves for oil injection	16.4	1310
AOHX 30..	Withdrawal sleeves for oil injection	16.4	1310
AOHX 31..	Withdrawal sleeves for oil injection	16.4	1310
AOHX 32..	Withdrawal sleeves for oil injection	16.4	1310
AP ..	Adapters, accessories for cam followers	-	1110
AS ..	Thin universal washers for needle roller and cage thrust assemblies	12.1	1070
A5 ..	Thin universal washers for needle roller thrust bearings	12.2	1074
AXK ..	Needle roller and cage thrust assemblies	12.1	1070
AXW ..	Needle roller thrust bearings with a centring flange	12.2	1074
BA ..	Single direction thrust ball bearings	10.1	1016
BK ..	Drawn cup needle roller bearings with a closed end	6.2	730
BMB-62..	Motor encoder units	15A.1	1166
BMO-62..	Motor encoder units	15A.1	1166
B52-22..-2CS	Sealed spherical roller bearings	8.2	928
B52-22..-2CS5	Sealed spherical roller bearings	8.2	928
B52-23..-2CS	Sealed spherical roller bearings	8.2	928
B5C-- V	Full complement CARB toroidal roller bearings	9.1	980
C 22..	CARB toroidal roller bearings	9.1	980
C 23..	CARB toroidal roller bearings	9.1	980
C 23../C4VG114	CARB toroidal roller bearings for vibratory applications	-	963
C 30..	CARB toroidal roller bearings	9.1	980
C 31..	CARB toroidal roller bearings	9.1	980
C 32..	CARB toroidal roller bearings	9.1	980
C 39..	CARB toroidal roller bearings	9.1	980
C 40..	CARB toroidal roller bearings	9.1	980
C 40..-2CS5V	Sealed full complement CARB toroidal roller bearings	9.2	996
C 41..	CARB toroidal roller bearings	9.1	980
C 41..-2CS5V	Sealed full complement CARB toroidal roller bearings	9.2	996
C 48..	CARB toroidal roller bearings	9.1	980
C 49..	CARB toroidal roller bearings	9.1	980
C 50.. V	Full complement CARB toroidal roller bearings	9.1	980

¹⁾ Starting page of the product table.

Designation	Product	Product table	
		No.	Page ¹⁾
C 59..	CARB toroidal roller bearings	9.1	980
C 59..-2CS5V	Sealed full complement CARB toroidal roller bearings	9.2	996
C 60.. V	Full complement CARB toroidal roller bearings	9.1	980
C 69.. V	Full complement CARB toroidal roller bearings	9.1	980
C 69..-2CS5V	Sealed full complement CARB toroidal roller bearings	9.2	996
CYS..	Y-bearings with an eccentric locking collar fitted with a rubber seating ring	-	463
E2.222..	SKF Energy Efficient spherical roller bearings	8.1	904
E2.32.. A	SKF Energy Efficient double row angular contact ball bearings	3.3	526
E2.320.. X	SKF Energy Efficient single row tapered roller bearings	7.1	824
E2.322..	SKF Energy Efficient single row tapered roller bearings	7.1	824
E2.323..	SKF Energy Efficient single row tapered roller bearings	7.1	824
E2.33.. A	SKF Energy Efficient double row angular contact ball bearings	3.3	526
E2.60..	SKF Energy Efficient single row deep groove ball bearings	1.2	346
E2.62..	SKF Energy Efficient single row deep groove ball bearings	1.2	346
E2.63..	SKF Energy Efficient single row deep groove ball bearings	1.2	346
E2.YAR 2..-2F	SKF Energy Efficient Y-bearings with grub screws, metric shafts	2.1	458
E2.YAR 2..-2F	SKF Energy Efficient Y-bearings with grub screws, inch shafts	2.2	460
E2.YET 2..	SKF Energy Efficient Y-bearings with an eccentric locking collar, metric shafts	2.3	464
E2.YET 2..	SKF Energy Efficient Y-bearings with an eccentric locking collar, inch shafts	2.4	466
E2.YSP 2.. SB-2F	SKF Energy Efficient ConCentra Y-bearings, metric shafts	2.5	468
E2.YSP 2.. SB-2F	SKF Energy Efficient ConCentra Y-bearings, inch shafts	2.6	469
EE 243..	Inch single row tapered roller bearings	7.2	842
EE 649..	Inch single row tapered roller bearings	7.2	842
EE 763..	Inch single row tapered roller bearings	7.2	842
EE 843..	Inch single row tapered roller bearings	7.2	842
GS 811..	Housing washers for single row cylindrical roller thrust bearings	11.1	1048
GS 811..	Housing washers for needle roller and cage thrust assemblies	12.1	1070
GS 812..	Housing washers for single row cylindrical roller thrust bearings	11.1	1048
GS 893..	Housing washers for double row cylindrical roller thrust bearings	11.1	1048
GS 894..	Housing washers for double row cylindrical roller thrust bearings	11.1	1048
H 2..	Adapter sleeves	16.1	1290
H 23..	Adapter sleeves	16.1	1290
H 3..	Adapter sleeves	16.1	1290
H 30..	Adapter sleeves	16.1	1290
H 31..	Adapter sleeves	16.1	1290
H 39..	Adapter sleeves	16.1	1290
H 9138..	Inch single row tapered roller bearings	7.2	842
HA 2..	Adapter sleeves for inch shafts	16.2	1298
HA 23..	Adapter sleeves for inch shafts	16.2	1298
HA 3..	Adapter sleeves for inch shafts	16.2	1298
HA 30..	Adapter sleeves for inch shafts	16.2	1298
HA 31..	Adapter sleeves for inch shafts	16.2	1298
HE 2..	Adapter sleeves for inch shafts	16.2	1298
HE 23..	Adapter sleeves for inch shafts	16.2	1298
HE 3..	Adapter sleeves for inch shafts	16.2	1298
HE 30..	Adapter sleeves for inch shafts	16.2	1298
HE 31..	Adapter sleeves for inch shafts	16.2	1298
HJ 10..	Angle rings for cylindrical roller bearings	5.1	604
HJ 2..	Angle rings for cylindrical roller bearings	5.1	604
HJ 22..	Angle rings for cylindrical roller bearings	5.1	604
HJ 23..	Angle rings for cylindrical roller bearings	5.1	604
HJ 3..	Angle rings for cylindrical roller bearings	5.1	604
HJ 4..	Angle rings for cylindrical roller bearings	5.1	604
HK ..	Drawn cup needle roller bearings with open ends	6.2	730
HM .. T	Lock nuts	16.5	1316
HM 2201..	Single row tapered roller bearings	7.1	824
HM 2311..	Inch single row tapered roller bearings	7.2	842
HM 2627..	Inch single row tapered roller bearings	7.2	842
HM 2664..	Inch single row tapered roller bearings	7.2	842
HM 30..	Lock nuts	16.7	1320
HM 31..	Lock nuts	16.7	1320
HM 8013..	Inch single row tapered roller bearings	7.2	842
HM 8031..	Inch single row tapered roller bearings	7.2	842
HM 8048..	Inch single row tapered roller bearings	7.2	842
HM 8070..	Inch single row tapered roller bearings	7.2	842
HM 885..	Inch single row tapered roller bearings	7.2	842
HM 886..	Inch single row tapered roller bearings	7.2	842
HM 894..	Inch single row tapered roller bearings	7.2	842

¹⁾ Starting page of the product table.

Product index

Designation	Product	Product table	
		No.	Page ¹⁾
HM 9032..	Inch single row tapered roller bearings	7.2	842
HM 9112..	Inch single row tapered roller bearings	7.2	842
HME 30..	Lock nuts	16.7	1320
HME 31..	Lock nuts	16.7	1320
HN ..	Full complement drawn cup needle roller bearings with open ends	6.2	730
ICOS-D1B..	ICOS oil sealed bearing units	1.3	374
IR ..	Needle roller bearing inner rings	6.13	790
JHM 7202..	Single row tapered roller bearings	7.1	824
JL 267..	Single row tapered roller bearings	7.1	824
JL 693..	Single row tapered roller bearings	7.1	824
JLM 1049..	Single row tapered roller bearings	7.1	824
JM 2051..	Single row tapered roller bearings	7.1	824
JM 5119..	Single row tapered roller bearings	7.1	824
JM 5156..	Single row tapered roller bearings	7.1	824
JM 7142..	Single row tapered roller bearings	7.1	824
JM 7382..	Single row tapered roller bearings	7.1	824
K ..	Needle roller and cage assemblies	6.1	722
K 811..	Single row cylindrical roller and cage thrust assemblies	11.1	1048
K 812..	Single row cylindrical roller and cage thrust assemblies	11.1	1048
K 893..	Double row cylindrical roller and cage thrust assemblies	11.1	1048
K 894..	Double row cylindrical roller and cage thrust assemblies	11.1	1048
KAM 12..	Self-aligning ball bearing / adapter sleeve kits	-	547
KM ..	Lock nuts	16.5	1316
KMD ..	Precision lock nuts	16.16	1340
KMFE ..	Lock nuts	16.13	1334
KMK ..	Lock nuts	16.12	1333
KML ..	Lock nuts	16.5	1316
KMT ..	Precision lock nuts	16.14	1336
KMTA ..	Precision lock nuts	16.15	1338
KR ..	Cam followers	14.6	1140
KRE ..	Cam followers, with an eccentric collar	14.6	1140
KRV ..	Cam followers, with a full complement roller set	14.6	1140
L 1834..	Inch single row tapered roller bearings	7.2	842
L 3272..	Inch single row tapered roller bearings	7.2	842
L 3570..	Inch single row tapered roller bearings	7.2	842
L 4323..	Inch single row tapered roller bearings	7.2	842
L 446..	Inch single row tapered roller bearings	7.2	842
L 454..	Inch single row tapered roller bearings	7.2	842
L 5552..	Inch single row tapered roller bearings	7.2	842
L 681..	Inch single row tapered roller bearings	7.2	842
L 8147..	Inch single row tapered roller bearings	7.2	842
L 8655..	Inch single row tapered roller bearings	7.2	842
LL 4834..	Inch single row tapered roller bearings	7.2	842
LL 5668..	Inch single row tapered roller bearings	7.2	842
LL 6392..	Inch single row tapered roller bearings	7.2	842
LM 1029..	Inch single row tapered roller bearings	7.2	842
LM 117..	Inch single row tapered roller bearings	7.2	842
LM 119..	Inch single row tapered roller bearings	7.2	842
LM 127..	Inch single row tapered roller bearings	7.2	842
LM 2411..	Inch single row tapered roller bearings	7.2	842
LM 2836..	Inch single row tapered roller bearings	7.2	842
LM 297..	Inch single row tapered roller bearings	7.2	842
LM 3616..	Inch single row tapered roller bearings	7.2	842
LM 3774..	Inch single row tapered roller bearings	7.2	842
LM 485..	Inch single row tapered roller bearings	7.2	842
LM 5013..	Inch single row tapered roller bearings	7.2	842
LM 5033..	Single row tapered roller bearings	7.1	842
LM 5679..	Inch single row tapered roller bearings	7.2	842
LM 6030..	Inch single row tapered roller bearings	7.2	842
LM 670..	Inch single row tapered roller bearings	7.2	842
LM 7397..	Inch single row tapered roller bearings	7.2	842
LM 7427..	Inch single row tapered roller bearings	7.2	842
LM 7709..	Inch single row tapered roller bearings	7.2	842
LM 7727..	Inch single row tapered roller bearings	7.2	842
LM 8066..	Inch single row tapered roller bearings	7.2	842
LR ..	Needle roller bearing inner rings	6.13	790
LS ..	Universal washers for single row cylindrical roller thrust bearings	11.1	1048

¹⁾ Starting page of the product table.

Designation	Product	Product table	
		No.	Page ¹⁾
LS ..	Universal washers for needle roller and cage thrust assemblies	12.1	1070
LS ..	Universal washers for needle roller thrust bearings	12.2	1074
M 2316..	Inch single row tapered roller bearings	7.2	842
M 2394..	Inch single row tapered roller bearings	7.2	842
M 2497..	Inch single row tapered roller bearings	7.2	842
M 3369..	Inch single row tapered roller bearings	7.2	842
M 3495..	Inch single row tapered roller bearings	7.2	842
M 8020..	Inch single row tapered roller bearings	7.2	842
M 845..	Inch single row tapered roller bearings	7.2	842
M 866..	Inch single row tapered roller bearings	7.2	842
M 880..	Inch single row tapered roller bearings	7.2	842
MB ..	Lock washers	16.6	1318
MBL ..	Lock washers	16.6	1318
MS 30..	Locking clips	16.8	1324
MS 31..	Locking clips	16.8	1324
N ..	Inch lock nuts	16.9	1326
N 0..	Inch lock nuts	16.9	1326
N 2..	Single row cylindrical roller bearings	5.1	604
N 3..	Single row cylindrical roller bearings	5.1	604
NA 22..	Support rollers without flange rings, with an inner ring	14.4	1132
NA 48..	Needle roller bearings with machined rings with flanges, with an inner ring	6.4	758
NA 49..	Needle roller bearings with machined rings with flanges, with an inner ring	6.4	758
NA 69..	Needle roller bearings with machined rings with flanges, with an inner ring	6.4	758
NAO ..	Needle roller bearings with machined rings without flanges, with an inner ring	6.6	774
NATR ..	Support rollers with flange rings, with an inner ring	14.5	1134
NATV ..	Support rollers with flange rings, with an inner ring	14.5	1134
NCF 18.. V	Single row full complement cylindrical roller bearings	5.3	644
NCF 22.. ECJB	High-capacity cylindrical roller bearings	5.2	640
NCF 22.. V	Single row full complement cylindrical roller bearings	5.3	644
NCF 23.. ECJB	High-capacity cylindrical roller bearings	5.2	640
NCF 28.. V	Single row full complement cylindrical roller bearings	5.3	644
NCF 29.. V	Single row full complement cylindrical roller bearings	5.3	644
NCF 30.. V	Single row full complement cylindrical roller bearings	5.3	644
NF ..	Single row cylindrical roller bearings	-	574
NJ 10..	Single row cylindrical roller bearings	5.1	604
NJ 2..	Single row cylindrical roller bearings	5.1	604
NJ 22..	Single row cylindrical roller bearings	5.1	604
NJ 23..	Single row cylindrical roller bearings	5.1	604
NJ 3..	Single row cylindrical roller bearings	5.1	604
NJ 4..	Single row cylindrical roller bearings	5.1	604
NJF .. ECJA	High-capacity cylindrical roller bearings	-	576
NJG 23.. VH	Single row full complement cylindrical roller bearings	5.3	644
NJP ..	Single row cylindrical roller bearings	-	574
NK ..	Needle roller bearings with machined rings with flanges, without an inner ring	6.3	744
NKI ..	Needle roller bearings with machined rings with flanges, with an inner ring	6.4	758
NKIA 59..	Needle roller / angular contact ball bearings	6.9	780
NKIB 59..	Needle roller / angular contact ball bearings	6.9	780
NKIS ..	Needle roller bearings with machined rings with flanges, with an inner ring	6.4	758
NKS ..	Needle roller bearings with machined rings with flanges, without an inner ring	6.3	744
NKX ..	Needle roller / thrust ball bearings, thrust bearing with a cage	6.11	786
NKXR ..	Needle roller / cylindrical roller thrust bearings	6.12	788
NNC 48.. CV	Double row full complement cylindrical roller bearings	5.4	656
NNC 49.. CV	Double row full complement cylindrical roller bearings	5.4	656
NNCF 48.. CV	Double row full complement cylindrical roller bearings	5.4	656
NNCF 49.. CV	Double row full complement cylindrical roller bearings	5.4	656
NNCF 50.. CV	Double row full complement cylindrical roller bearings	5.4	656
NNCL 48.. CV	Double row full complement cylindrical roller bearings	5.4	656
NNCL 49.. CV	Double row full complement cylindrical roller bearings	5.4	656
NNF 50.. ADA-2LSV	Sealed double row full complement cylindrical roller bearings	5.5	668
NNF 50.. ADB-2LSV	Sealed double row full complement cylindrical roller bearings	5.5	668
NNTR ..	Support rollers with flange rings, with an inner ring	14.5	1134
NP ..	Single row cylindrical roller bearings	-	574
NU 10..	Single row cylindrical roller bearings	5.1	604
NU 10../C3VL0241	INSOCOAT single row cylindrical roller bearings	15E.2	1214
NU 10../C3VL2071	INSOCOAT single row cylindrical roller bearings	15E.2	1214
NU 10../HC5	Hybrid single row cylindrical roller bearings	15F.4	1238
NU 12..	Single row cylindrical roller bearings	5.1	604
NU 2..	Single row cylindrical roller bearings	5.1	604
NU 2../C3VL0241	INSOCOAT single row cylindrical roller bearings	15E.2	1214

¹⁾ Starting page of the product table.

Product index

Designation	Product	Product table	
		No.	Page ¹⁾
NU 2../C3VL2071	INSOCOAT single row cylindrical roller bearings	15E.2	1214
NU 2../HC5	Hybrid single row cylindrical roller bearings	15F.4	1238
NU 20..	Single row cylindrical roller bearings	5.1	604
NU 22..	Single row cylindrical roller bearings	5.1	604
NU 23..	Single row cylindrical roller bearings	5.1	604
NU 3..	Single row cylindrical roller bearings	5.1	604
NU 3../C3VL0241	INSOCOAT single row cylindrical roller bearings	15E.2	1214
NU 3../C3VL2071	INSOCOAT single row cylindrical roller bearings	15E.2	1214
NU 3../HC5	Hybrid single row cylindrical roller bearings	15F.4	1238
NU 4..	Single row cylindrical roller bearings	5.1	604
NUB ..	Single row cylindrical roller bearings	-	574
NUH 22.. ECMH	High-capacity cylindrical roller bearings	5.2	640
NUH 23.. ECMH	High-capacity cylindrical roller bearings	5.2	640
NUKR ..	Cam followers	14.6	1140
NUKRE ..	Cam followers, with an eccentric collar	14.6	1140
NUP 2..	Single row cylindrical roller bearings	5.1	604
NUP 22..	Single row cylindrical roller bearings	5.1	604
NUP 23..	Single row cylindrical roller bearings	5.1	604
NUP 3..	Single row cylindrical roller bearings	5.1	604
NUTR ..	Support rollers with flange rings, with an inner ring	14.5	1134
NX ..	Needle roller / thrust ball bearings, full complement thrust bearing	6.10	784
OH 23..	Adapter sleeves for oil injection	16.1	1290
OH 30..	Adapter sleeves for oil injection	16.1	1290
OH 31..	Adapter sleeves for oil injection	16.1	1290
OH 32..	Adapter sleeves for oil injection	16.1	1290
OH 39..	Adapter sleeves for oil injection	16.1	1290
OSNP ..	Inch adapter sleeves for oil injection	-	1270
OSNW ..	Inch adapter sleeves for oil injection	-	1270
PL ..	Inch locking plates	16.11	1332
PNA ..	Alignment needle roller bearings, with an inner ring	6.8	778
PWKR ..	Cam followers	14.6	1140
PWKRE ..	Cam followers, with an eccentric collar	14.6	1140
PWTR ..	Support rollers with flange rings, with an inner ring	14.5	1134
QJ 2..	Four-point contact ball bearings	3.4	530
QJ 3..	Four-point contact ball bearings	3.4	530
RIS 2..	Rubber seating rings	-	436
RN ..	Single row cylindrical roller bearings without an outer ring	-	572
RN .. ECJB	High-capacity cylindrical roller bearings without an outer ring	-	576
RN-..	Needle rollers	6.14	794
RNA 22..	Support rollers without flange rings, without an inner ring	14.3	1130
RNA 48..	Needle roller bearings with machined rings with flanges, without an inner ring	6.3	744
RNA 49..	Needle roller bearings with machined rings with flanges, without an inner ring	6.3	744
RNA 69..	Needle roller bearings with machined rings with flanges, without an inner ring	6.3	744
RNA0 ..	Needle roller bearings with machined rings without flanges, without an inner ring	6.5	770
RNU ..	Single row cylindrical roller bearings without an inner ring	-	572
RNU .. ECJA	High-capacity cylindrical roller bearings without an inner ring	-	576
RPNA ..	Alignment needle roller bearings, without an inner ring	6.7	776
RSTO ..	Support rollers without flange rings, without an inner ring	14.3	1130
SNP 1..	Inch adapter sleeves	16.3	1304
SNP 30..	Inch adapter sleeves	16.3	1304
SNP 31..	Inch adapter sleeves	16.3	1304
SNP 32..	Inch adapter sleeves	16.3	1304
SNW ..	Inch adapter sleeves	16.3	1304
SNW 1..	Inch adapter sleeves	16.3	1304
SNW 30..	Inch adapter sleeves	16.3	1304
SNW 31..	Inch adapter sleeves	16.3	1304
STO ..	Support rollers without flange rings, with an inner ring	14.4	1132
T2DD ..	Single row tapered roller bearings	7.1	824
T2ED ..	Single row tapered roller bearings	7.1	824
T2EE ..	Single row tapered roller bearings	7.1	824
T3FE ..	Single row tapered roller bearings	7.1	824
T4CB ..	Single row tapered roller bearings	7.1	824
T4DB ..	Single row tapered roller bearings	7.1	824
T4EB ..	Single row tapered roller bearings	7.1	824
T4EE ..	Single row tapered roller bearings	7.1	824

¹⁾ Starting page of the product table.

Designation	Product	Product table	
		No.	Page ¹⁾
T7FC..	Single row tapered roller bearings	7.1	824
T7FC../DT	Single row tapered roller bearings, matched for mounting in tandem	7.6	876
U 2..	Seat washers for thrust ball bearings	10.2	1026
U 2..	Seat washers for thrust ball bearings	10.4	1034
U 3..	Seat washers for thrust ball bearings	10.2	1026
U 3..	Seat washers for thrust ball bearings	10.4	1034
U 4..	Seat washers for thrust ball bearings	10.2	1026
U 4..	Seat washers for thrust ball bearings	10.4	1034
VD1	Plug, accessory for cam followers	-	1108
W ..	Inch lock washers	16.10	1330
W 0..	Inch lock washers	16.10	1330
W 60..	Stainless steel deep groove ball bearings	1.6	386
W 60..-2RS1	Sealed stainless steel deep groove ball bearings	1.7	394
W 60..-2Z	Shielded stainless steel deep groove ball bearings	1.7	394
W 60..-2ZS	Shielded stainless steel deep groove ball bearings	1.7	394
W 617..	Stainless steel deep groove ball bearings	1.6	386
W 617..-2RS1	Sealed stainless steel deep groove ball bearings	1.7	394
W 617..-2Z	Shielded stainless steel deep groove ball bearings	1.7	394
W 617..-2ZS	Shielded stainless steel deep groove ball bearings	1.7	394
W 618..	Stainless steel deep groove ball bearings	1.6	386
W 618..-2RS1	Sealed stainless steel deep groove ball bearings	1.7	394
W 618..-2Z	Shielded stainless steel deep groove ball bearings	1.7	394
W 619..	Stainless steel deep groove ball bearings	1.6	386
W 619..-2RS1	Sealed stainless steel deep groove ball bearings	1.7	394
W 619..-2Z	Shielded stainless steel deep groove ball bearings	1.7	394
W 62..	Stainless steel deep groove ball bearings	1.6	386
W 62..-2RS1	Sealed stainless steel deep groove ball bearings	1.7	394
W 62..-2Z	Shielded stainless steel deep groove ball bearings	1.7	394
W 62..-2ZS	Shielded stainless steel deep groove ball bearings	1.7	394
W 63..	Stainless steel deep groove ball bearings	1.6	386
W 63..-2RS1	Sealed stainless steel deep groove ball bearings	1.7	394
W 63..-2Z	Shielded stainless steel deep groove ball bearings	1.7	394
W 630..-2Z	Shielded stainless steel deep groove ball bearings	1.7	394
W 630..-2ZS	Shielded stainless steel deep groove ball bearings	1.7	394
W 637..2Z	Shielded stainless steel deep groove ball bearings	1.7	394
W 637..-2ZS	Shielded stainless steel deep groove ball bearings	1.7	394
W 638..	Stainless steel deep groove ball bearings	1.6	386
W 638..-2RS1	Sealed stainless steel deep groove ball bearings	1.7	394
W 638..-2Z	Shielded stainless steel deep groove ball bearings	1.7	394
W 639..-2RS1	Sealed stainless steel deep groove ball bearings	1.7	394
W 639..-2Z	Shielded stainless steel deep groove ball bearings	1.7	394
W 639..-2ZS	Shielded stainless steel deep groove ball bearings	1.7	394
WS 811..	Shaft washers for single row cylindrical roller thrust bearings	11.1	1048
WS 811..	Shaft washers for needle roller and cage thrust assemblies	12.1	1070
WS 811..	Shaft washers for needle roller thrust bearings	12.2	1074
WS 812..	Shaft washers for single row cylindrical roller thrust bearings	11.1	1048
WS 893..	Shaft washers for double row cylindrical roller thrust bearings	11.1	1048
WS 894..	Shaft washers for double row cylindrical roller thrust bearings	11.1	1048
YAR 2..-2F	Y-bearings with grub screws, metric shafts	2.1	458
YAR 2..-2F	Y-bearings with grub screws, inch shafts	2.2	460
YAR 2..-2FW/VA201	Y-bearings for extreme temperatures, metric shafts	15B.2	1182
YAR 2..-2FW/VA201	Y-bearings for extreme temperatures, inch shafts	15B.3	1183
YAR 2..-2FW/VA228	Y-bearings for extreme temperatures, metric shafts	15B.2	1182
YAR 2..-2FW/VA228	Y-bearings for extreme temperatures, inch shafts	15B.3	1183
YAR 2..-2RF	Y-bearings with grub screws, metric shafts	2.1	458
YAR 2..-2RF	Y-bearings with grub screws, inch shafts	2.2	460
YAR 2..-2RF/HV	Stainless steel Y-bearings with grub screws, metric shafts	2.1	458
YAR 2..-2RF/HV	Stainless steel Y-bearings with grub screws, inch shafts	2.2	460
YAR 2..-2RF/VE495	Y-bearings with grub screws for the food industry, metric shafts	2.1	458
YAR 2..-2RF/VE495	Y-bearings with grub screws for the food industry, inch shafts	2.2	460
YARAG 2..	Y-bearings with grub screws for agricultural applications, metric shafts	2.1	458
YARAG 2..	Y-bearings with grub screws for agricultural applications, inch shafts	2.2	460
YAT 2..	Y-bearings with grub screws, metric shafts	2.1	458
YAT 2..	Y-bearings with grub screws, inch shafts	2.2	460
YEL 2..-2F	Y-bearings with an eccentric locking collar, metric shafts	2.3	464
YEL 2..-2F	Y-bearings with an eccentric locking collar, inch shafts	2.4	466
YEL 2..-2RF	Y-bearings with an eccentric locking collar, metric shafts	2.3	464

¹⁾ Starting page of the product table.

Product index

Designation	Product	Product table	
		No.	Page ¹⁾
YELAG 2..	Y-bearings with an eccentric locking collar for agricultural applications, metric shafts	2.3	464
YELAG 2..	Y-bearings with an eccentric locking collar for agricultural applications, inch shafts	2.4	466
YET 2..	Y-bearings with an eccentric locking collar, metric shafts	2.3	464
YET 2..	Y-bearings with an eccentric locking collar, inch shafts	2.4	466
YSA 2..-2FK	Y-bearings with a tapered bore, metric shafts	2.7	470
YSA 2..-2FK	Y-bearings with a tapered bore, inch shafts	2.8	471
YSP 2.. SB-2F	SKF ConCentra Y-bearings, metric shafts	2.5	468
YSP 2.. SB-2F	SKF ConCentra Y-bearings, inch shafts	2.6	469
YSPAG 2..	SKF ConCentra Y-bearings for agricultural applications, metric shafts	2.5	468
YSPAG 2..	SKF ConCentra Y-bearings for agricultural applications, inch shafts	2.6	469

¹⁾ Starting page of the product table.

