



Rexnord and Link-Belt Engineered Steel Chains

Section Index

Description	Page
Special Application Chain	4-9
Engineered Steel	
With Rollers	10-13
Without Rollers	14
Attachments	15-29
Drive Chains	30-35
Welded Steel Chains	
Chains	36-42
Attachments	43-46
Cast Chains	
Chains	47-52
Cast Chain Attachments	53-55
Flight Wings Attachments	56
Drop Forge Chains	
Chains	57
Attachments	58-61
Live Roller Chains	62
Double Flex Chains	63-64
Other Products and Information	
Rexnord and Link-Belt Interchange	65
Sprockets	66-84
Buckets	85-86
Other Products and Information	
Design and Selection	87-113
Maintenance Information	114-119
Engineering Data	120-128
Chain and Sprocket Index	129-131
Subject Index	132-133

Special Application Chain

High Performance Elevator Chains*

Rexnord Heavy Duty Elevator chains have garnered a reputation as the longest lasting, most reliable chains available today for tough elevating applications. Our chains are the most efficient and reliable to elevate all types of material including clinker, finished cement, fertilizer, and coal.

The 900 series chains are the newest addition to this line of chains. With larger components, the 900 series offers 30% greater fatigue strength over their 800 series counterparts. Lightening holes were added to the 900 series to offset the increased weight introduced by larger bushings and pins.

No matter which series you choose, you're guaranteed the highest level of heat treatment and manufacturing available in elevator chains today.

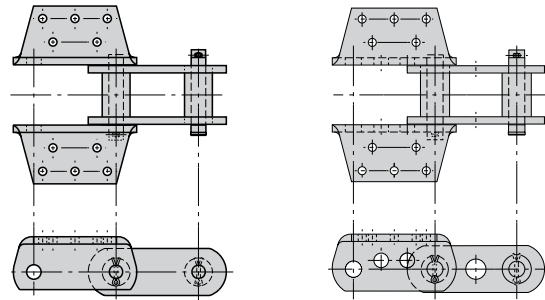

800 Series
ER856
ER857
ER859
ER864

900 Series
ER956
ER958
ER984

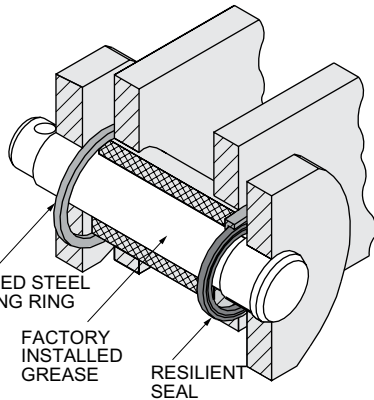

Sealed Joint Elevator Chains
Factory installed grease sealed in, abrasives or corrosives sealed out. An option in these chains and denoted by the "SJM" prefix.



Linkmaster®

Keep the advantage of high press fits by using the Linkmaster assembly and disassembly tool. See page 119 for more details.

* Contact Rexnord for more details.

Grain Handling Chains

Rexnord manufactures a wide variety of chains for the grain industry. Welded steel chains are very popular due to the fact that they are easily modified by welding on a variety of attachments. Press fit engineered steel chains with rollers are used in longer, higher load systems. The chains shown are examples of these two chain types.

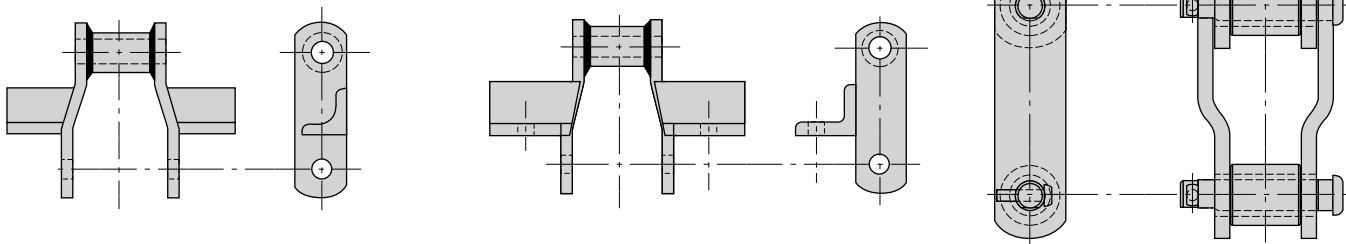

The ER series replaces the S, ES, RS, X and SX series chains.

Special Application Chain

Rexnord And Link-Belt Engineered Chain Application for Amusement Rides, Recreational Lifts, and Other People Movers

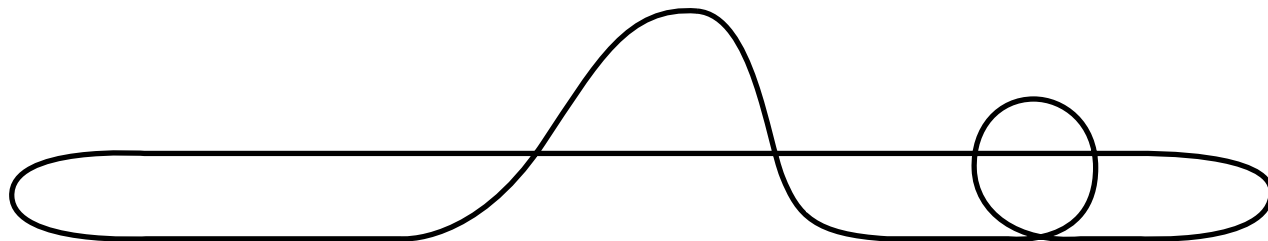

From time to time, chain application questions concerning driving or conveying functions on amusement rides and recreational lifts are brought to Rexnord's attention. Concern arises for the safety and the well being of people utilizing these units should chains prematurely or unexpectedly fail. A general review has been made to establish certain rules and recommendations for the selection and application of these rides and conveyances. The following reflects those conclusions:

1. Chain should not be used for any amusement ride or recreational lift application unless there are adequate, functional, and operational safety backup devices to prevent hazardous or unsafe conditions from occurring.
2. Chains containing castings or molded parts of any material should not be applied to these applications. This includes pintle, heavy pintle, combination, cast steel, nonmetallic, and similar chains.
3. Cast or welded base chains should not be used in these applications. Welded attachments and other weldments used to augment an engineered steel base chain will be considered on a case by case basis.
4. Applications where a new chain selection is being made will only be considered for customers with qualified engineering expertise. Chain selections of any nature should not be made or changed without written approval of the appropriate representatives of an approved Original Equipment Manufacturer (OEM) of that equipment. This includes replacement chains from any manufacturer including Rexnord. Requests involving like for like replacements will be considered for all customers. Written approval is required for each purpose.
5. Chain selections for amusement rides or recreational lift applications should be of the engineered steel types of chain generally covered by ANSI standards B29.10, B29.12, and B29.15 after review of all application factors by and approval of the appropriate responsible representative of the original equipment manufacturer of the equipment.
6. Chains on these applications should be adequately lubricated and properly maintained at all times.
7. Chain reliability is based upon a good press fit of the pins and bushings into the sidebars. Therefore, do not grind the chain pins, bushings, or holes in the sidebars in order to assemble the chain as supplied from the factory.
8. Alteration of chain destroys the integrity of the press fits of the chain assembly. Therefore, do not alter or rebuild any chains for these applications.
9. If a customer applies an engineered chain product without our approval, it is a misapplication and, as such, is not covered by warranty under our standard conditions of sale.

Should questions arise covering any of these policies or procedures, please contact your local Rexnord sales representative.

Special Application Chain

In-Floor Conveying Chain

Rexnord and Link-Belt In-Floor Conveyor chains are specially designed to move continuous loads, such as those found in the paper, steel and automotive industries. Rexnord manufactures a variety of configurations to accommodate a multitude of applications.

A complete selection of materials, top plates and pitch lengths are also offered.

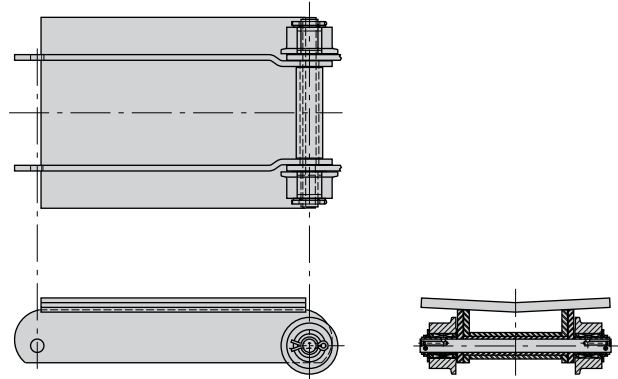

Draw Bench and Steel Industry Chains

Hot steel slabs, coiled steel and metal tubing all move smoothly on our chains. Rollers, if needed, are fully machined and supplied with bearings. The large laced chains shown to the right are for draw benches used in the tube industry. These chains are fully machined on Rexnord's modern CNC milling machines.

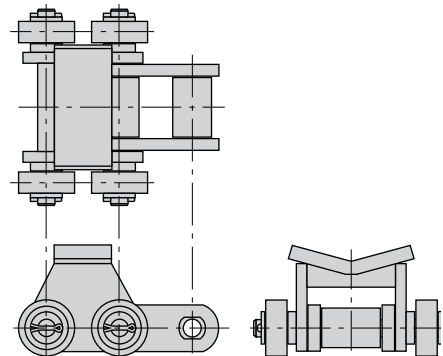
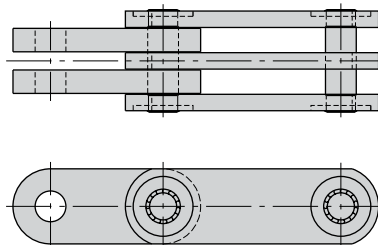
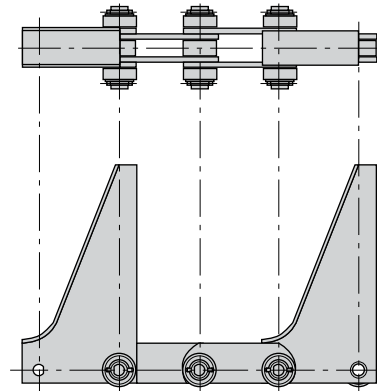
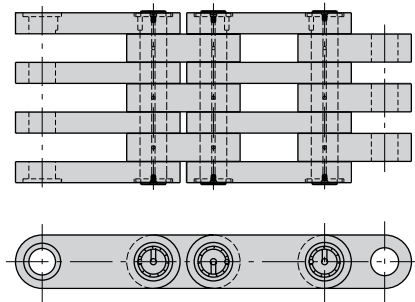

Special Application Chain

Reclaimer and Barge/Ship Unloading Chains

Many types of reclaimers and barge/ship unloaders use large engineered class chains. Rexnord can design new chains for these applications, or build replacement chains if given a sample. Below are some examples of chains we have made, but the styles we can make are virtually limitless.

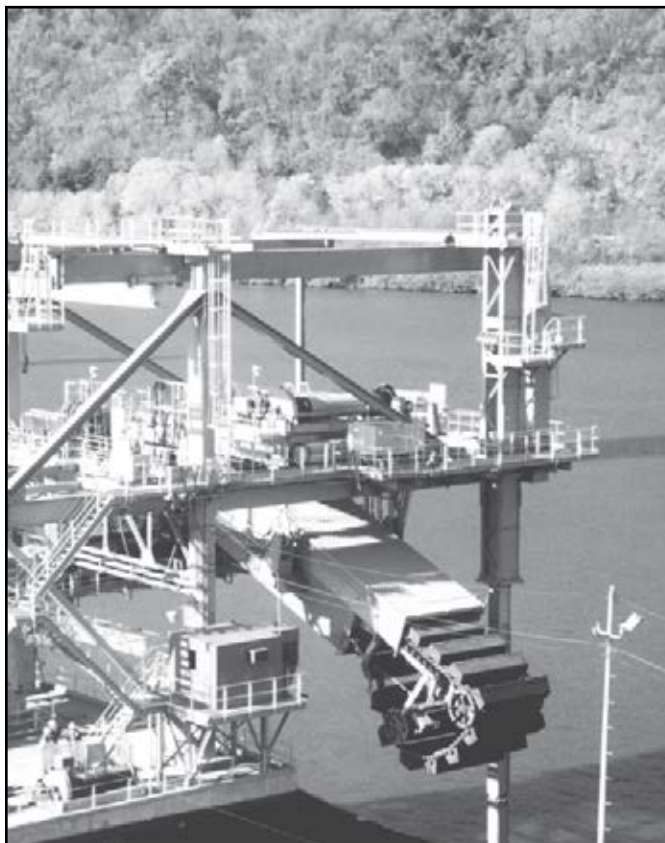
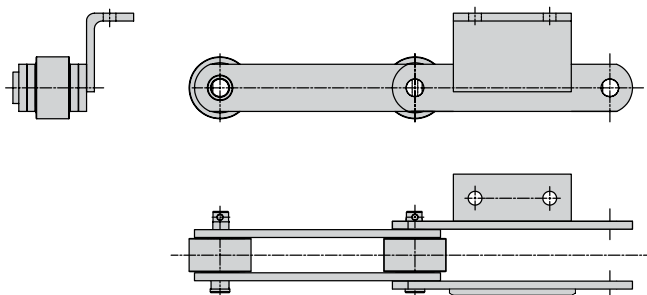

Bottling and Beverage Industry

Some of the most commonly used engineered chains in the bottling industry are bottle washer chains. Rexnord makes a wide variety of these chains that meet or exceed OEM specifications. Chains and attachments can be modified to help solve maintenance problems. Below are some examples of chains we make.

Side-flexing chains are also very common in bottling. Rexnord has one of the broadest lines of steel side-flexing chains for barrel, case and pallet conveying.

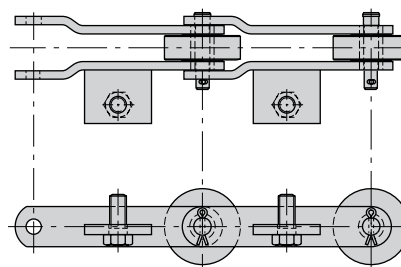
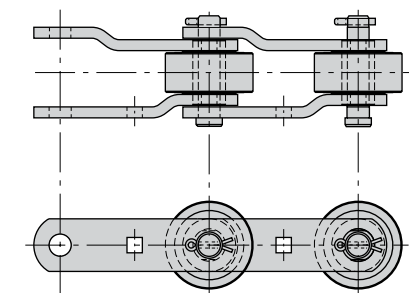
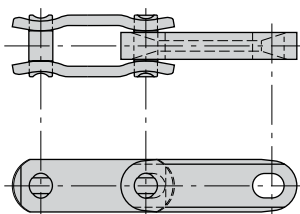

Special Application Chain

Cane Sugar and Sugar Beet Processing

Bagasse, intermediate, feed tables and main cane carrier chains are all available from Rexnord. Many sugar processing chains are the same as they were years ago when mills were smaller. Today's larger mills require newer, stronger chains such as the Rexnord FX9184 – a larger version of the FX2184. Contact Rexnord for a copy of the latest Sugar Mill Chains brochure.

Many chain styles are available for sugar beet processing as well. As in cane sugar processing, this industry is very corrosive. Special materials and platings are also available.

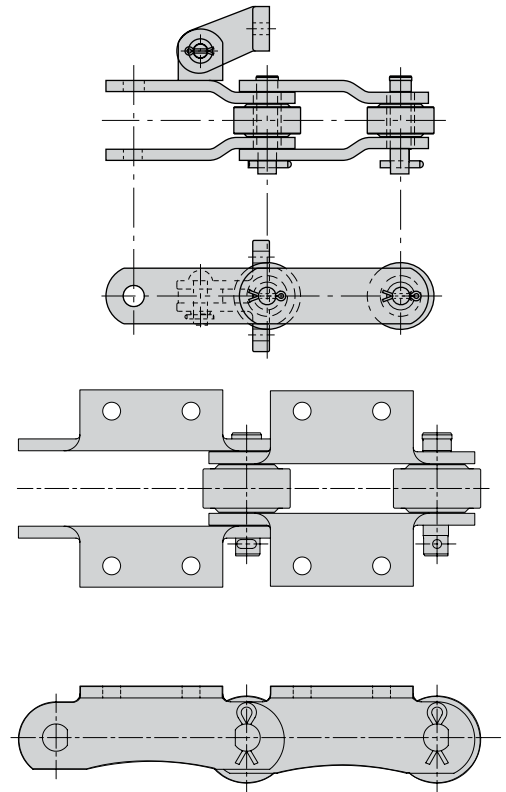

Food Processing

Engineered chain is used throughout the food processing industry. Some typical applications include hydrostatic cookers, overhead carcass conveyors, cutting tables and vegetable process conveyors. Examples of some of the metallic chain configurations used in this industry are shown below.

Rexnord offers a wide variety of material and/or coating options to combat the corrosive elements generally found in these applications.

Chains for the baking industry (oven, proofer, etc.) are also available. Contact Rexnord for details.

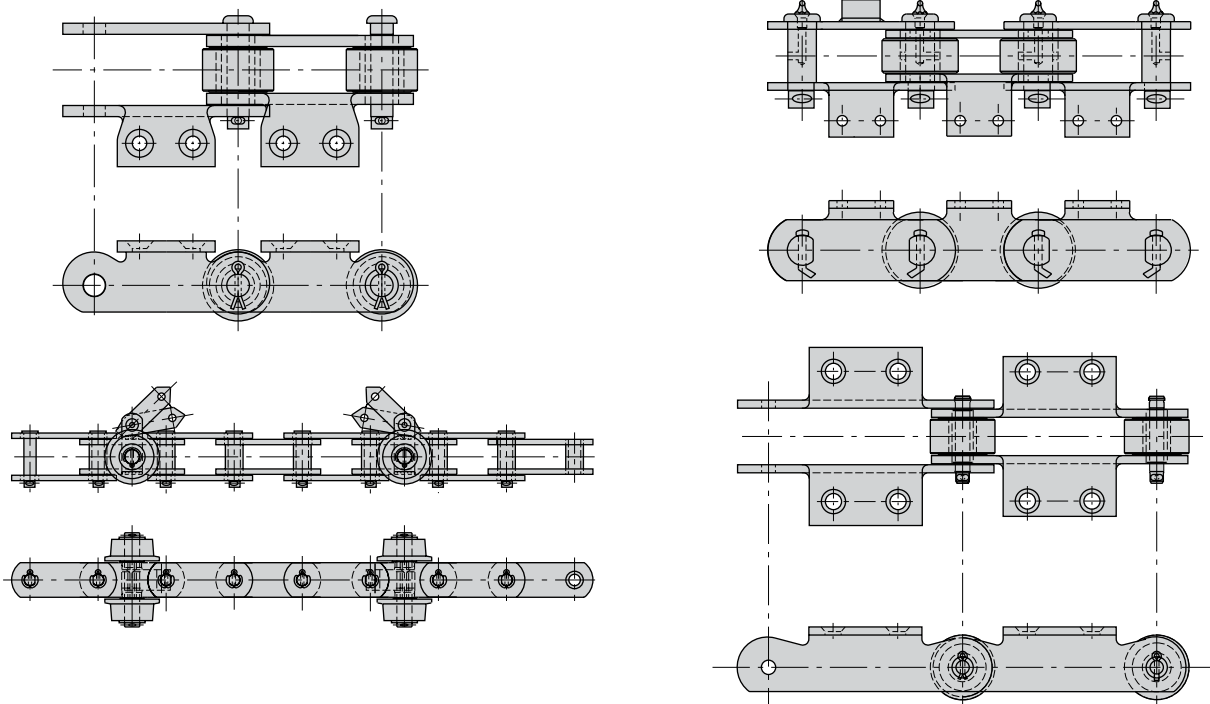

Special Application Chain

Distribution and Material Handling

Today's large postal and consumer goods distribution centers rely heavily upon engineered chains to sort and move product.

In-floor tow chains for automated cart conveyors are also made by Rexnord. Call for details.

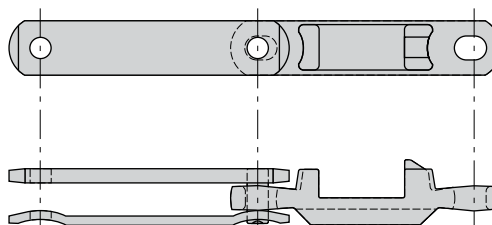

High Sidebar Conveyor Chain and General Conveying Chain

Rexnord and Link-Belt High Sidebar Conveyor chains offer superior strength for conveying heavy loads, such as those found in the automotive, steel and general assembly industries. It rolls comfortably on any even, firm surface to provide efficient, economical conveying. Versions with intermediate rollers are available for accumulation conveyors.

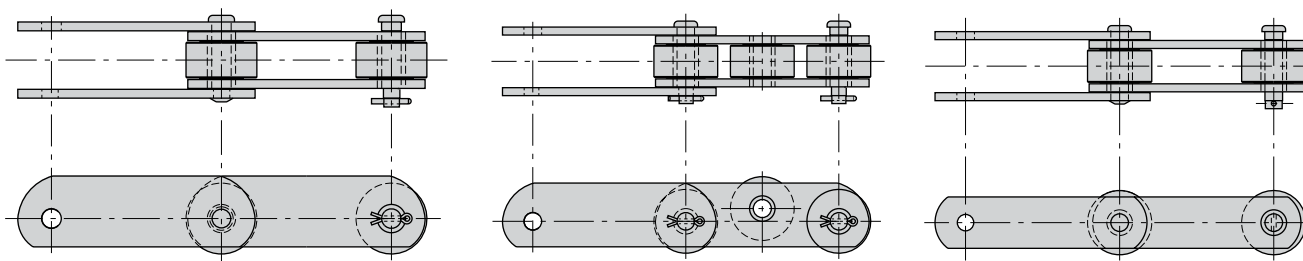

Engineered Steel - With Rollers

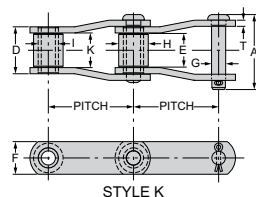

STYLE K

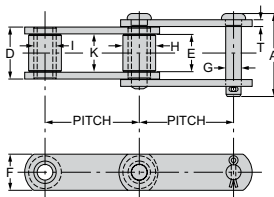

STYLE N

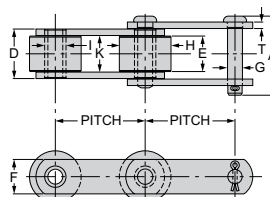

STYLE R

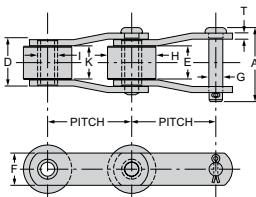

STYLE W

Properties
 TH Thru-Hardened
 CARB Carburized
 CIH Circumferentially Induction Hardened
 SIH Selectively Induction Hardened
 WI White Iron

Dimensions are in inches. Strengths, loads and weights are in pounds.

Rexnord Chain No.	Link-Belt Chain No.	Style	Average Pitch	Rated Working Load	Rec. Maximum R.P.M. for 12 T. Spkt. ①	Minimum Ultimate Strength, Lbs.x10 ³	Average Weight Per Foot	Overall Pin & Cotter	Sidebars			Pins		Rollers		Bushings		Sprocket Unit No. ②								
									Between Sidebars	Thickness	Height	Diam.	Face Width	Outside Diam.	Style	Properties	Length		Outside Diam.							
									A	K	T	F	G	E	H	D	I									
1.654-2.609-Inch Pitch																										
RR362	RS625	N	1.654	1,650	280	8	3.0	2.03	1.00	.13	1.13	.38	CARB	.97	.88	A	TH	1.25	.56	62						
RR432	RS627	N	1.654	2,100	280	21	3.7	2.28	1.00	.19	1.13	.44	TH	.97	.88	A	TH	1.38	.63	62						
81X	RS81X	N	2.609	2,000	145	16	2.5	2.14	1.07	.16	1.13	.43	CARB	1.00	.88	A	TH	1.39	.63	78						
C1288	SS1088	N	2.609	2,000	145	16	2.5	2.23	1.08	.16	1.13	.41	CARB	1.03	.90	A	CARB	1.38	.63	78						
1578	-	K	2.609	2,200	145	17	2.6	2.36	1.06	.19	1.00	.44	CARB	1.03	.90	A	CARB	1.44	.63	78						
RR778	RS886	N	2.609	2,300	145	23	2.9	2.41	1.13	.19	1.13	.44	CARB	1.08	.88	A	TH	1.50	.63	78						
RR588	RS887	N	2.609	2,500	145	17	3.8	2.67	1.13	.25	1.13	.44	CARB	1.08	.88	A	TH	1.63	.63	78						
81XH	RS81XH	N	2.609	2,500	145	28	4.1	2.58	1.07	.31③	1.27	.43	TH	1.00	.88	A	TH	1.69	.63	78						
81XHH	RS81XHH	N	2.609	2,500	145	28	4.6	2.76	1.07	.31	1.27	.43	TH	1.00	.88	A	TH	1.69	.63	78						
270	SS2004	N	2.609	3,500	145	40	6.9	2.95	1.14	.31	1.63	.56	TH	1.09	1.13	A	TH	1.77	.81	270						
7774	-	N	2.609	3,500	145	40	6.4	3.01	1.13	.31	1.63	.56	TH	1.06	1.13	A	TH	1.75	.81	270						
3.000-3.075-3.110-Inch Pitch																										
-	RS303	N	3.000	1,340	115	6	2.0	1.54④	.50	.19	1.00	.44	CARB	.48	.88	A	CARB	.88	.63	303						
SR183	RS3013	R	3.000	2,100	115	22	4.0	2.25	1.00	.19	1.13	.44	CARB	.97	1.50	A	CARB	1.38	.63	183						
A4539	-	N	3.075	4,650	110	38	6.8	3.47	1.50	.31	1.50	.63	SIH	1.45	1.25	A	CARB	2.13	.88	4539						
1539	RS1539	N	3.075	4,650	110	24	6.8	3.50	1.50	.31	1.50	.63	CARB	1.45	1.25	A	TH	2.13	.89	1030						
7539	-	N	3.110	4,650	110	40	9.1	3.47	1.50	.31	1.75	.63	SIH	1.40	1.38	A	TH	2.13	1.00	7539						
4.000-Inch Pitch																										
RR1120	RS4013	R	4.000	2,100	75	13	3.4	2.28	1.00	.19	1.13	.44	TH⑤	.90	1.50	A	CARB⑤	1.38	.63	1120						
-	RS4113	R	4.000	2,300	75	13	4.2	2.32	1.13	.19	1.13	.44	CARB	1.09	1.75	A	CARB	1.50	.63	188						
SR194	RS4216	R	4.000	2,350	75	15	5.3	2.47	1.19	.19	1.25	.44	CARB	1.09	2.00	A	CARB	1.56	.63	194						
SR188	-	R	4.000	2,400	75	13	4.2	2.47	1.19	.19	1.13	.44	CARB	1.06	1.75	A	CARB	1.56	.63	188						
4	RS4019	R	4.000	2,500	75	21	4.2	2.50	.82	.25	1.25	.50	CARB	.88	1.50	A	CARB	1.46	.75	1120						
2188	RS2188	R	4.000	4,200	75	23	7.0	3.25	1.31	.31	1.50	.63	CARB	1.25	1.75	A	CARB	1.94	.94	188						
531	RS4328	R	4.000	4,500	75	28	9.7	3.47	1.31	.38	1.50	.63	CARB⑤	1.25	2.25	A	CARB	2.06	.94	531						
ER3433	-	N	4.000	5,300	75	41	9.0	4.30	2.13	.38	1.50	.63	SIH	2.06	1.50	A	CARB	2.88	1.00	3433						
A2868	-	N	4.000	7,200	75	57	12.1	4.36	2.00	.38	1.75	.75	SIH	1.95	1.44	A	CARB	2.75	1.06	2868						
4.040-4.083-4.500-Inch Pitch																										
3420	RS1113	R	4.040	4,300	75	23	7.6	3.25	1.31	.31	1.50	.63	CARB	1.25	2.00	A	CARB	1.94	.94	1113						
-	RO2113	W	4.040	4,300	75	18	8.0	3.14	1.31	.31	1.50	.69	CARB	1.25	2.00	A	CARB	1.94	1.00	2113						
C2848	-	N	4.040	6,600	75	48	11.0	4.26	2.00	.38	2.00	.69	SIH	1.94	1.50	A	TH	2.75	1.00	2848						
2858	-	N	4.083	7,200	75	57	13.0	4.37	2.00	.38	2.25	.75	SIH	1.94	1.63	A	CARB	2.75	1.13	2858						
3285	-	N	4.500	10,500	60	91	21.0	4.94	2.06	.50	2.50	.94	SIH	1.95	2.00	A	TH	3.06	1.31	3285						

① If driver has more/less than 12 teeth, increase/decrease RPM in direct ratio of number of teeth to 12. Do not exceed a chain speed of 450 FPM.

② Fabricated steel sprockets are recommended.

③ Outer (pin-link) sidebars are .21 inches thick.

④ Extended rivet.

⑤ Heat treatment and dimension specifications for Rexnord Chain; Contact Rexnord for Link-Belt specifications.

Engineered Steel - With Rollers

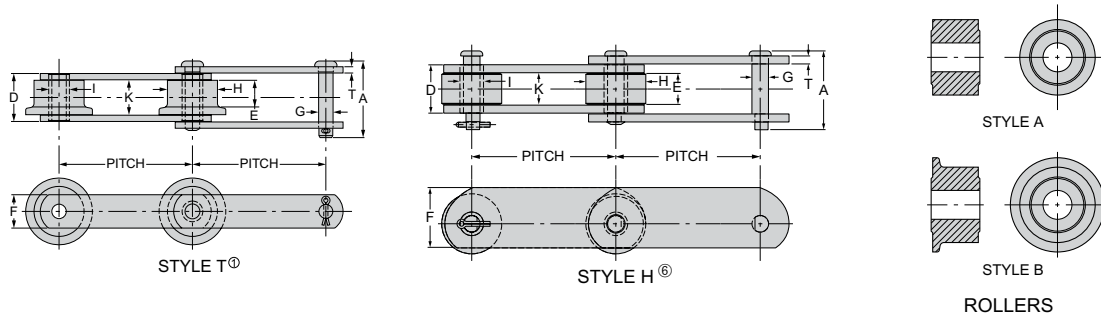

- Properties**
- TH Thru-Hardened
 - CARB Carburized
 - CIH Circumferentially Induction Hardened
 - SIH Selectively Induction Hardened
 - WI White Iron

Dimensions are in inches. Strengths, loads and weights are in pounds.

Rexnord Chain No.	Link-Belt Chain No.	Style	Average Pitch	Rated Working Load	Rec. Maximum R.P.M. for 2 T. Spkt. ^①	Minimum Ultimate Strength Lbs.x10 ³	Average Weight Per Foot	Overall Pin & Cotter	Sidebars				Pins	Rollers				Bushings			
									Between Sidebars	Thickness	Height	Diam.		Face Width	Outside Diam.	Style	Properties	Length	Outside Diam.	Sprocket Unit No.	
A	K	T	F	G	E	H	A	K	T	F	G	E	H	A	CARB	CIH	SIH	WI	D	I	②
6.000-Inch Pitch																					
SR196	RS6018	R	6.000	2,600	40	18	5.0	2.72	1.19	0.25	1.50	0.44	CARB	1.09	2.00	A	CARB	1.69	0.63	196	
1604	-	W	6.000	2,800	40	20	5.3	2.69	1.06	0.25	1.25	0.50	CARB	0.88	3.00	A	WI	1.56	0.72	1604	
2126	RS1116	R	6.000	3,400	40	21	5.0	2.89	1.25	0.25	1.50	0.56	CARB	1.19	2.00	A	CARB	1.75	0.81	196	
2190	RS2190	R	6.000	3,400	40	21	7.0	2.89	1.25	0.25	1.50	0.56	CARB	1.19	2.50	A	CARB	1.75	0.81	197	
1670	-	R	6.000	4,100	40	23	6.3	3.25	1.31	0.31	1.50	0.63	CARB	1.19	2.25	A	CARB	1.94	0.94	2180	
SR1114	RS1114	R	6.000	4,200	40	23	6.3	3.25	1.31	0.31	1.50	0.63	CARB	1.25	2.00	A	CARB	1.94	0.94	196	
2180	-	R	6.000	4,500	40	35	8.7	3.47	1.31	0.38	1.75	0.63	CARB	1.19	2.25	A	CARB	2.06	0.94	2180	
S951	-	R	6.000	4,500	40	37	10.7	3.47	1.31	0.38	2.00	0.63	CARB	1.19	3.00	A	CARB	2.06	0.94	S951	
2183	RS951	R	6.000	4,600	40	24	10.7	3.50	1.50	0.31	1.50	0.63	CARB	1.38	3.00	A	CARB	2.13	0.89	1131	
F2183	-	T	6.000	4,600	40	24	11.1	3.50	1.50	0.31	1.50	0.63	CARB	1.13	3.00	B	WI	2.13	0.88	S951	
1036	-	K	6.000	4,600	40	24	4.8	3.50	1.50	0.31	1.50	0.63	CARB	1.45	1.25	A	TH	2.13	0.88	1036	
-	RS658	T ^⑦	6.000	4,650	40	18	9.6	3.32	1.50	0.31	1.50	0.63	CARB	1.13	3.00	B	WI	2.13	0.89	1604	
1617	-	H	6.000	4,800	40	43	11.0	3.28	1.38	0.31	2.50	0.69	CARB	1.22	2.50	A	CARB	2.00	1.00	197	
SR3130	-	W	6.000	5,200	40	45	10.0	3.53	1.25	0.38	2.00	0.75	CARB	0.94	2.50	A	CARB	2.00	1.13	197	
6	RS6238	R	6.000	5,600	40	45	11.0	3.67	1.38	0.38	2.00	0.75	TH ^⑧	1.31	2.50	A	CARB	2.13	1.13	197	
6 Sp.	-	R	6.000	5,600	40	45	12.2	3.66	1.38	0.38	2.00	0.75	TH	1.25	3.00	A	CARB	2.13	1.13	1131	
-	RS953	N	6.000	5,600	40	27	8.7	3.57	1.38	0.38	2.00	0.75	TH	1.31	1.75	A	CARB	2.13	1.13	953	
-	RS6438	R	6.000	5,600	40	45	12.6	3.57	1.38	0.38	2.00	0.75	CIH	1.31	3.00	A	CARB	2.13	1.12	1131	
RR542	-	N	6.000	6,000	40	28	5.7	4.05	2.13	0.31	1.50	0.63	CARB	2.06	1.25	A	TH	2.75	0.89	110	
BR2111	RS944+	N	6.000	5,900	40	67	9.6	3.84	1.56	0.38	2.00	0.75	TH	1.50	1.88	A	CARB	2.31	1.25	2111	
C2124	-	R	6.000	6,000	40	63	11.8	3.84	1.56	0.38	2.00	0.75	TH	1.25	2.75	A	CARB	2.31	1.13	2124	
A2124 ^③	RS996	R	6.000	6,000	40	63	11.8	3.84	1.56	0.38	2.00	0.75	TH	1.44	2.75	A	CARB	2.31	1.13	2124	
RS1131	RS1131	R	6.000	6,000	40	45	12.5	3.84	1.56	0.38	2.00	0.75	TH	1.38	3.00	A	CARB	2.31	1.13	1131	
FX2184	RO2184	W	6.000	6,500	40	58	12.3	3.76	1.38	0.38	2.00	0.88	CIH	1.06	3.00	A	CARB	2.13	1.25	1131	
FX9184	-	W	6.000	8,300	40	100	15.2	4.41	1.56	0.50	2.50	0.94	CIH	1.20	3.00	A	CARB	2.53	1.38	9184	
A2178 ^⑤	-	R	6.000	7,000	40	56	15.3	3.88	1.56	0.38	2.00	0.88	CIH	1.25	2.75	A	CARB	2.31	1.25	2124	
A2198 ^⑤	RS960	R	6.000	7,650	40	101	18.2	4.43	1.56	0.50	2.25	0.88	CIH	1.25	2.75	A	CARB	2.56	1.30	2124	
-	RS2047 ^④	R	6.000	7,800	40	98	32.0	3.94	1.63	0.38	2.50	0.94	TH	1.57	3.00	A	CARB	2.38	1.38	2047	
5208	-	K	6.000	8,950	40	54	10.5	4.90	1.94	0.50	2.00	0.88	CIH	1.88	1.75	A	TH	2.94	1.25	5208	
-	RS2600 ^④	R	6.000	11,900	40	112	30.0	4.98	2.66	0.38	3.00	1.00	TH	2.29	3.50	A	TH	3.41	1.50	2600	
C9856	-	N	6.000	14,000	40	97	22.1	5.96	3.00	0.50	2.75	1.00	CIH	2.88	2.75	A	CARB	4.00	1.50	9856	
B9856	-	N	6.000	14,000	40	97	22.1	5.56	3.00	0.50	2.50	1.00	CIH	2.88	2.75	A	CARB	4.00	1.50	9856	

^① If driver has more/less than 12 teeth, increase/decrease RPM in direct ratio of number of teeth to 12. Do not exceed a chain speed of 450 FPM.

^② Fabricated steel sprockets are recommended.

^③ Plated pin.

^④ Chain furnished with attachments every pitch.

^⑤ Lower edge of sidebar is necked.

^⑥ Centerline of sidebar is .25" higher than centerline of roller. Sidebar extends .25" above roller.

^⑦ When assembled with through rods, the roller flange is on the side opposite the end of the rod.

^⑧ Heat treatment and dimension specifications for Rexnord Chain; Contact Rexnord for Link-Belt specifications.

Note: "+" denotes "plus".

Engineered Steel - With Rollers

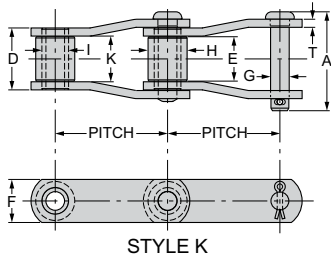

STYLE K

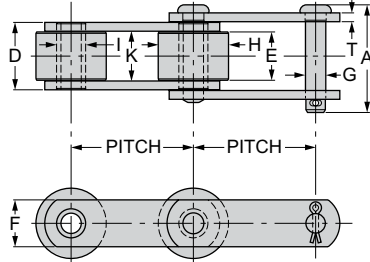

STYLE R

Properties

TH	Thru-Hardened
CARB	Carburized
CIH	Circumferentially Induction Hardened
SIH	Selectively Induction Hardened
WI	White Iron

Dimensions are in inches. Strengths, loads and weights are in pounds.

Rexnord Chain No.	Link-Belt Chain No.	Style	Average Pitch	Rated Working Load	Rec. Maximum R.P.M. for 2 T. Spkt. ①	Minimum Ultimate Strength, Lbs.x10 ³	Average Weight Per Foot	Overall Pin & Cotter	Between Sidebars		Sidebars		Pins		Rollers		Bushings		Sprocket Unit No. ②	
									A	K	T	F	G	Properties	Face Width	Outside Diam.	Style	Properties		Length
8.000-Inch Pitch																				
A2800	-	R	8.000	9,800	26	94	62.2	4.71	1.81	.50	2.75	1.00	CIH	1.50	3.50	A	CARB	2.81	1.50	2800
-	RS2800 ③	R	8.000	11,900	26	112	30.0	4.98	2.66	.38	3.75	.94	TH	2.28	3.50	A	TH	3.41	1.50	2800
-	RS2804 ③	R	8.000	24,300	26	150	47.0	6.86	3.64	.50	3.50	1.50	TH	3.20	4.25	A	TH	4.64	1.99	2804
9.000-Inch Pitch																				
1039	-	K	9.000	4,650	22	24	4.3	3.50	1.50	.31	1.50	.63	CARB	1.45	1.25	A	TH	2.13	.88	1039
ER911	RS911	R	9.000	4,650	22	33	8.5	3.45	2.00 ⑥	.31	2.00	.63	CARB	1.44	3.00	A	CARB	2.13	.89	E911
-	SS928	T ⑤	9.000	7,200	22	29	8.5	4.20	2.00	.38	2.00	.75	TH	1.69	1.86	A	NONE	2.75	1.13	SS928
ER922	SS927	R	9.000	7,200	22	34	12.0	4.28	2.00	.38	2.00	.75	TH	1.94	3.50	A	WI	2.75	1.13	E922
FR922	SS922	T ⑤	9.000	7,200	22	34	12.5	4.28	2.00	.38	2.00	.75	TH	1.31	3.50	B	WI	2.75	1.13	F922
R2342	-	K	9.000	9,000	22	54	9.2	4.80	1.94	.50	2.00	.88	CIH	1.90	1.75	A	CARB	2.94	1.25	2342
R2405	-	K	9.000	9,000	22	88	9.7	4.80	1.94	.50	2.13	.88	TH	1.88	1.75	A	CARB	2.94	1.25	2342
ER933	-	R	9.000	9,200	22	53	15.6	4.72	2.25	.38	2.50	.88	TH	1.75	4.00	E	WI	3.00	1.25	E933
-	SS942	T ⑤	9.000	9,200	22	39	12.4	4.57	2.25	.38	2.50	.88	TH	2.19	2.38	A	NONE	3.00	1.25	SS942
FR933	SS933	T ⑤	9.000	9,200	22	48	16.5	4.61	2.25	.38	2.50	.88	TH	1.56	4.00	B ⑥	WI	3.00	1.25	F933
R4009 ④	RS4851	R	9.000	9,200	22	67	14.7	4.60	2.25	.38	2.50	.88	CIH ⑥	2.13	3.00	A	TH	3.00	1.27	4009
X4004 ④	RS4852	R	9.000	12,700	22	65	18.5	5.69	2.63	.50	2.50	1.00	CIH	2.56	3.00	A	CARB ⑥	3.63	1.50	4004
4065 ④	RS4065	R	9.000	18,900	22	148	36.2	6.52	3.06	.63	3.50	1.25	CIH	3.00	4.25	A	CARB	4.31	2.00	4065
-	RS2064	R	9.000	19,700	22	105	28.0	5.90	2.75	.50	3.50	1.50	TH	2.69	3.50	A	TH	3.75	2.13	2064

- ① If driver has more/less than 12 teeth, increase/decrease RPM in direct ratio of number of teeth to 12. Do not exceed a chain speed of 450 FPM.
- ② Fabricated steel sprockets are recommended.
- ③ Chain furnished with attachment every pitch.
- ④ Furnished as standard with G5 attachment every second pitch.
- ⑤ When assembled with through rods, the roller flange is on the side opposite the end of the rod.
- ⑥ Heat treatment and dimension specifications for Rexnord Chain; Contact Rexnord for Link-Belt specifications.

Engineered Steel - With Rollers

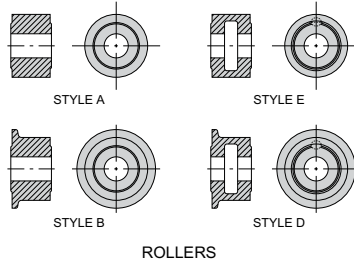
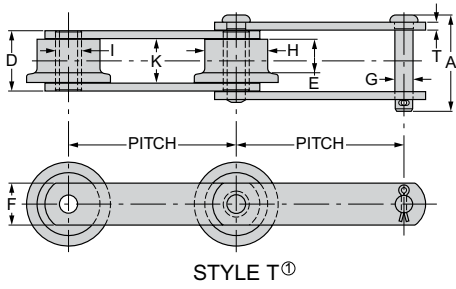

Properties	
TH	Thru-Hardened
CARB	Carburized
CIH	Circumferentially Induction Hardened
SIH	Selectively Induction Hardened
WI	White Iron

Dimensions are in inches. Strengths, loads and weights are in pounds.

Rexnord Chain No.	Link-Belt Chain No.	Style	Average Pitch	Rated Working Load	Rec. Maximum R.P.M. for 12 T. Spkt. ^①	Minimum Ultimate Strength, Lbs.x10 ³	Average Weight Per Foot	Overall Pin & Cotter	Between Sidebars		Sidebars		Pins		Rollers		Bushings		Sprocket Unit No. ^②	
									A	K	T	F	G	Face Width	Outside Diam.	Style	Properties	Length		Outside Diam.
12.000-Inch Pitch																				
E1211	RS1211	R	12,000	4,650	14	31	7.0	3.44	1.50	.31	2.00	.63	CARB	1.38	3.00	A	CARB	2.13	.89	E1211
-	SS4038	R	12,000	6,200	14	29	9.0	3.82	1.63	.38	2.00	.75	TH	1.56	3.25	A	WI	2.38	1.13	4038
ER1222	SS1227	R	12,000	7,200	14	34	10.0	4.31	2.00	.38	2.00	.75	TH	1.63	3.50	A	WI	2.75	1.13	E1222
FR1222	SS1222	T	12,000	7,200	14	34	10.5	4.31	2.00	.38	2.00	.75	TH	1.25	3.50	D ^⑤	WI	2.75	1.13	F1222
-	SS1232	T	12,000	7,200	14	46	12.0	4.20	2.00	.38	2.00	.75	TH	1.31	4.50	B	WI	2.75	1.13	F1232
R1251	-	K	12,000	9,000	14	56	9.8	4.90	1.94	.50	2.00	.88	CARB	1.88	1.75	A	CARB	2.94	1.25	2397
ER1233	-	R	12,000	9,200	14	61	13.1	4.64	2.25	.38	2.50	.88	TH	1.75	4.00	E	WI	2.94	1.25	E1233
FR1233	SS1233	T	12,000	9,200	14	62	14.0	4.64	2.25	.38	2.50	.88	TH	1.56	4.00	D ^⑤	WI	2.94	1.25	F1233
RR2397	-	K	12,000	9,200	14	60	9.5	4.64	2.25	.38	2.50	.88	CARB	2.19	1.75	A	CARB	3.00	1.25	2397
4011 ^③	-	R	12,000	9,200	14	63	12.6	4.62	2.25	.38	2.50	.88	AC	2.12	3.00	A	TH	3.00	1.25	4011
-	RS4850	R	12,000	9,200	14	63	12.7	4.57	2.19	.38	2.50	.88	TH	2.13	3.00	A	TH	2.94	1.26	4011
ER1244	-	R	12,000	12,300	14	85	20.5	5.53	2.63	.50	2.50	1.00	TH	2.50	5.00	A	CARB	3.63	1.50	E1244
FR1244	-	T	12,000	12,300	14	63	21.50	5.53	2.63	.50	2.50	1.00	TH	1.75	5.00	D	WI	3.63	1.50	F1244
R1706	-	K	12,000	14,000	14	79	13.90	5.99	3.00	.50	2.50	1.00	CIH	2.94	2.25	A	CARB	4.00	1.50	2452
R2614	-	K	12,000	17,500	14	135	24.0	6.26	2.75	.63	3.50	1.25	CIH	2.69	2.50	A	CARB	4.00	1.75	2614
R4010 ^④	-	R	12,000	23,500	14	185	39.2	6.79	3.25	.63	4.00	1.50	CIH	3.09	4.50	A	CARB	4.50	2.13	4010
18.000-Inch Pitch																				
ER1822	-	R	18,000	7,200	8	34	8.5	4.31	2	.38	2.00	.75	TH	1.63	3.50	A	WI	2.75	1.13	E1822
FR1822	-	T	18,000	7,200	8	34	9.0	4.31	2	.38	2.00	.75	TH	1.25	3.50	D	WI	2.75	1.13	F1822
F1833	-	T	18,000	9,200	8	63	11.5	4.72	2.25	.38	2.50	.88	TH	1.50	4.00	D	WI	3.00	1.25	F1833
FR1844	-	T	18,000	12,300	8	89	17.0	5.66	2.63	.50	2.50	1.00	TH	1.75	5.00	D	WI	3.63	1.50	F1844

① If driver has more/less than 12 teeth, increase/decrease RPM in direct ratio of number of teeth to 12. Do not exceed a chain speed of 450 FPM.

② Fabricated steel sprockets are recommended.

③ Furnished as standard with G116 attachment every second pitch.

④ Furnished as standard with G5 attachment every second pitch.

⑤ Heat treatment and dimension specifications for Rexnord Chain; Contact Rexnord for Link-Belt specifications.

Engineered Steel - Without Rollers

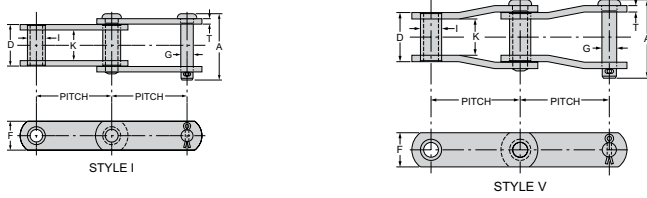

Properties

TH	Thru-Hardened
CARB	Carburized
CIH	Circumferentially Induction Hardened
SIH	Selectively Induction Hardened
WI	White Iron

Dimensions are in inches. Strengths, loads and weights are in pounds.

Rexnord Chain No.	Link- Belt Chain No.	Style	Average Pitch	Rated Working Load	Rec. Maximum R.P.M. for 12 T. Spt. ①	Minimum Ultimate Strength, Lbs. x 10 ³	Average Weight Per Foot	Overall Pin & Cotter	Between Sidebars	Sidebars		Properties	Pins		Bushings		Sprocket Unit No. ②	
										Thickness	Height		Diam.	Properties	Length	Outside Diam.		
									A	K	T	F	G	D	I			
1.506-Inch Pitch																		
-	SS152	I	1.506	1,230	280	6	2.2	1.81	.81	.16	.88	TH	.31	CARB	1.13	.63	152	
2.609-Inch Pitch																		
S188	SBS188	I	2.609	2,740	145	23	3.8	2.69	1.06	.25	1.13	TH	.50	CARB	1.57	.88	78	
3.075-Inch Pitch																		
ER131	SBS131	I	3.075	4,450	110	36	7.4	3.52	1.31	.38	1.50	TH	.63	CARB	2.06	1.25	103	
1536	SBS1972	I	3.075	4,900	110	51	9.2	3.56	1.50	.38	1.75	TH	.63	TH	2.26	1.25	1536	
-	SBO2103	V	3.075	5,000	110	28	5.6	3.03	1.38	.25	1.50	TH	.75	CARB	1.88	1.25	103	
1535	SBS2162	I	3.075	5,300	110	50	9.4	3.58	1.38	.38	1.75	TH	.75	CARB	2.14	1.25	1535	
4.000-Inch Pitch																		
R2823	-	V	4.000	3,170	75	21	3.2	2.94	1.31	.25	1.13	TH	.50	CARB	1.81	.78	823	
S823	-	V	4.000	3,450	75	22	5.2	3.08	1.47	.25	1.25	TH	.50	CARB	1.97	.78	823	
SR825	-	V	4.000	6,000	75	55	8.7	3.87	1.56	.38	2.00	TH	.75	CARB	2.31	1.14	825	
ER102B	SBS102B	I	4.000	6,300	75	36	6.9	4.37	2.13	.38	1.50	TH	.63	CARB	2.89	1.00	102B	
-	SBS2236	I	4.000	9,900	75	119	19.2	4.90	1.91	.56	2.38	TH	.94	CARB	3.03	1.75	2236	
4.040-Inch Pitch																		
ER102.5	SBS102.5	I	4.040	7,800	75	48	9.4	4.56	2.25	.38	1.75	TH	.75	CARB	3.01	1.38	1021/2	
4.760-Inch Pitch																		
ER111	SBS111	I	4.760	8,850	55	48	10.2	4.97	2.63	.38	2.00	TH	.75	SIH	3.39	1.44	111	
4.760- and 7.240-Inch Pitch																		
ER111Sp ^⑦	-	I	4.760 7.240	8,850	40	48	8.8	4.97	2.63	.38	2.00	TH	.75	SIH	3.38	1.44	111Sp.	
6.000-Inch Pitch																		
SR830	-	I	6.000	6,000	40	50	7.5	3.87	1.56	.38	2.00	TH	.75	CARB	2.31	1.16	830	
ER110	SBS110	I	6.000	6,300	40	36	6.3	4.37	2.13	.38	1.50	TH	.63	CIH	2.89	1.25	110	
ER833	-	I	6.000	8,900	40	48	9.3	4.97	2.63	.38	2.00	TH	.75	SIH	3.38	1.44	833	
SR844	SBS844	V ^⑦	6.000	9,000	40	52	10.4	5.31	2.50	.50	2.00	TH	.75	CARB	3.50	1.15	844	
6826	-	V	6.000	9,600	40	68	12.0	5.03	2.38	.38	2.50	TH	.88	SIH	3.13	1.50	6826	
ER856	SBX856	I	6.000	14,000	40	82	16.5	5.99	3.00	.50	2.50	TH	1.00	CIH	4.00	1.75	856	
ER956 ^③	-	I	6.000	14,000	40	97	16.6	5.99	2.95	.50	3.00 ^⑤	TH	1.00	CIH	4.00	1.75	856	
ER857 ^③	SBX2857	I	6.000	14,000	40	97	21.0	5.99	3.00	.50	3.25	TH	1.00	CIH	4.00	1.75	856	
-	SBS850+	I	6.000	16,000	40	128	25.3	6.18	2.25	.63	3.00	TH	1.31	SIH	3.51	2.00	RO850	
RO850	SBO850+	V	6.000	16,100	40	1428	24.6	6.18	2.25	.63	3.00	TH	1.31	CIH	3.51	2.00	RO850	
ER958	-	I	6.000	16,300	40	97	21.0	6.07	3.00	.56	3.25	TH	1.13	CIH	4.13	2.00	958	
-	SS1654	I	6.000	18,300	40	175	35.4	6.38	2.25	.63	4.00 ^⑥	TH	1.50	SIH	3.51	2.50	1654	
ER859 ^③	SBX2859	I	6.000	22,000	40	155	34.0	7.62	3.75	.63	4.00 ^⑥	TH	1.25	CIH ^⑦	5.00	2.38	859	
-	SBO6065	V	6.000	27,600	40	420	51.7	6.86	3.00	.75	4.75	TH	1.75	TH	4.50	3.00	6065	
6.010 to 9.000-Inch Pitch																		
ER150	SBS150+	I	6.050	15,000	40	85	16.6	6.36	3.34	.50	2.50	TH	1.00	SIH	4.35	1.75	132	
ERA150 ^④	-	I	6.050	15,000	40	82	16.6	6.34	3.34	.50	2.50	TH	1.00	SIH	4.34	1.75	132	
SX175	-	I	6.050	18,500	40	114	24.5	6.69	3.19	.63	3.00	TH	1.19	CIH	4.44	2.00	SX175	
ER864 ^③	SBX2864	I	7.000	22,000	40	155	33.0	7.62	3.75	.63	4.00 ^⑥	TH	1.25	CIH	5.00	2.38	864	
ER984	-	I	7.000	24,000	40	155	33.0	7.35	3.75	.62	4.00	TH	1.38	CIH	5.00	2.50	984	
SX886	-	V	7.000	24,000	40	255	42.0	6.79	2.75	.75	4.00	TH	1.63	CIH	4.25	2.63	SX886	
-	SBS4871	I	9.000	15,300	40	91	14.6	6.21	3.38	.50	3.00	TH	1.00	SIH	4.35	1.75	1903	

① If driver has more/less than 12 teeth, increase/decrease RPM in direct ratio of number of teeth to 12. Do not exceed a chain speed of 450 FPM.
 ② Fabricated steel sprockets are recommended.
 ③ Both pins in a pin link have their heads on the same side. In the assembled chain the pin links are staggered.
 ④ Induction hardened sidebar edges furnished as standard.
 ⑤ Outer (pin-link) sidebars are 2.50 inches high.
 ⑥ Outer (pin-link) sidebars are 3.00 inches high.
 ⑦ Heat treatment and dimension specifications for Rexnord Chain; Contact Rexnord for Link-Belt specifications.
 Note: "+" denotes "plus".

Engineered Steel - Attachments

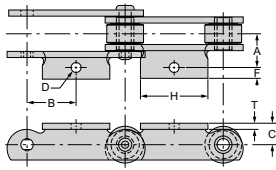

A1 Rexnord

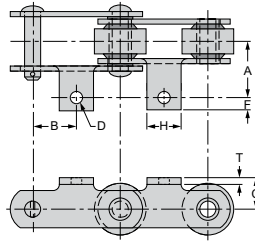

A1 Link-Belt

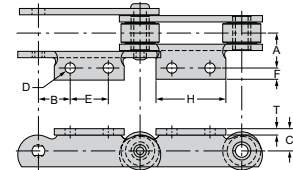

A2 Rexnord

Dimensions are in inches. Weights are in pounds.

Rexnord Chain No.	Link-Belt Chain No.	A	B	C	D		E	F	G	H	J	K	T	Wgt. Per Foot
					Bolt Dia.	Bolt Hole								
A1														
4	-	1.38	2.00	.88	3/8	.41	-	.53	-	2.75	-	-	.25	4.7
SR183 ^①	-	1.47	1.50	.81	5/16	.34	-	.53	-	2.00	-	-	.19	4.4
SR194	-	2.00	2.00	1.13	3/8	.41	-	.63	-	3.25	-	-	.19	6.3
SR196	-	2.00	3.00	1.25	3/8	.41	-	.76	-	3.50	-	-	.25	6.6
S188	-	1.88	1.31	.81	3/8	.41	-	.69	-	2.12	-	-	.25	4.5
RR432	-	1.38	.83	.81	1/4	.28	-	.41	-	1.00	-	-	.19	4.0
RR588	-	1.94	1.31	.88	5/16	.34	-	.90	-	2.13	-	-	.25	4.0
RR778	-	1.94	1.31	.88	5/16	.34	-	.72	-	2.13	-	-	.19	2.6
RR1120	-	1.38	2.00	.81	3/8	.41	-	.63	-	2.50	-	-	.19	3.6
1539	-	1.88	1.53	1.25	1/2	.56	-	.70	-	3.00	-	-	.31	7.9
2188	-	1.69	2.00	1.00	3/8	.41	-	1.03	-	2.75	-	-	.31	7.9
-	RS625	1.19	.83	.69	1/4	.31	-	.53	-	.88	-	-	.13	3.2
-	RS627	1.38	.83	.81	1/4	.28	-	.53	-	1.00	-	-	.19	4.6
-	RS1539	1.88	1.53	1.25	1/2	.56	-	.65	-	2.75	-	-	.31	7.9
-	RS2188	1.81	2.00	1.00	1/2	.56	-	.85	-	3.00	-	-	.31	7.9
-	RS3013	1.47	1.50	.81	5/16	.34	-	.43	-	2.25	-	-	.19	4.5
-	RS4013	1.38	2.00	.81	3/8	.41	-	.53	-	2.50	-	-	.19	3.9
-	RS4019	1.38	2.00	.88	3/8	.41	-	.51	-	2.50	-	-	.25	4.8
-	RS4113	1.72	2.00	1.00	3/8	.41	-	.59	-	2.50	-	-	.19	4.7
-	S4216	2.00	2.00	1.13	3/8	.41	-	.61	-	3.38	-	-	.19	5.6
-	S4328	2.00	2.00	1.25	1/2	.56	-	.88	-	2.00	-	-	.38	10.7
A2 made also for chain with offset sidebars.														
4	-	1.38	1.25	.88	3/8	.41	1.50	.53	-	2.75	-	-	.25	4.7
6	-	2.13	1.69	1.63	1/2	.53	2.63	.72	-	5.50	-	-	.38	13.0
6 Sp.	-	2.13	1.69	1.63	1/2	.53	2.63	.72	-	5.50	-	-	.38	14.2
A2124	-	2.19	1.50	1.63	1/2	.53	3.00	.71	-	4.50	-	-	.38	13.8
SR183 ^①	-	1.56	.97	.81	1/4	.28	1.06	.44	-	2.00	-	-	.19	4.6
SR188 ^①	-	2.00	.75 ^②	1.00	3/8	.41	2.00 ^②	.52	-	3.38	-	-	.19	4.9
SR194	-	2.00	1.00	1.13	3/8	.41	2.00	.63	-	3.25	-	-	.19	6.3
SR196	-	2.00	2.00	1.25	3/8	.41	2.00	.76	-	3.50	-	-	.25	6.6
E911	-	2.56	2.75	1.75	1/2	.53	3.50	1.00	-	5.50	-	-	.25	10.6
FR922	-	2.88	2.75	2.50	1/2	.53	3.50	1.00	-	5.50	-	-	.25	14.6
FR933	-	3.00	2.75	2.88	1/2	.53	3.50	.90	-	5.50	-	-	.31	19.4
ER102B	-	2.66	1.13	1.13	3/8	.41	1.75	.81	-	4.25	-	-	.38	9.4
S188	-	2.09	.67	.81	5/16	.34	1.25	.47	-	2.13	-	-	.25	4.5
S951	-	2.19	2.00	1.63	3/8	.41	2.00	.84	-	3.50	-	-	.25	12.7
SR1114	-	2.00	2.00	1.13	3/8	.41	2.00	.69	-	3.50	-	-	.31	8.5
RS1131	-	3.00	1.69	1.63	1/2	.56	2.63	.69	-	4.50	-	-	.38	15.5
1539	-	2.00	.59	1.25	5/16	.34	1.88	.58	-	3.00	-	-	.31	7.9
2126	-	2.00	2.00	1.13	3/8	.41	2.00	.75	-	3.50	-	-	.25	6.0
2180	-	2.38	2.00	1.63	1/2	.56	2.00	.81	-	3.50	-	-	.38	10.2
2188	-	1.81	1.13	1.00	1/2	.56	1.75	.91	-	2.75	-	-	.31	7.9
3420	-	2.06	1.27	1.25	3/8	.41	1.50	1.00	-	2.75	-	-	.31	9.3

① A1/A2 and K1/K2 attachments may be combined on the same sidebar.

② Not Central.

Note: Most attachments are thru-hardened.

Engineered Steel - Attachments

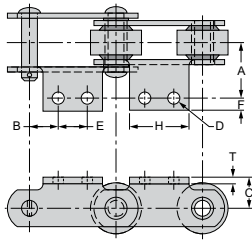

A2 Figure 1

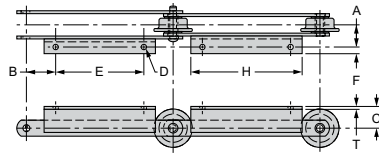

A2 Figure 2

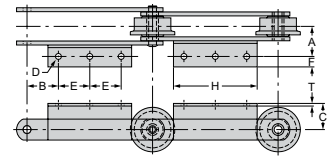

A3 Rexnord

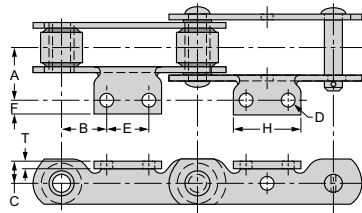

A3 Link-Belt

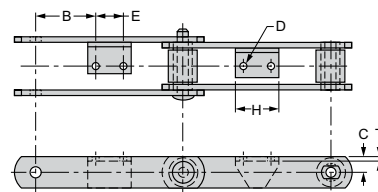

A5

Dimensions are in inches. Weights are in pounds.

Rexnord Chain No.	Link-Belt Chain No.	A	B	C	D		E	F	G	H	J	K	T	Wgt. Per Foot
					Bolt Dia.	Bolt Hole								
A2 Figure 1														
-	RS658	2.63	1.50	2.50	3/8	.44	3.00	.79	-	4.38	-	-	.31	12.2
-	RS886	2.09	.67	.81	5/16	.34	1.25	.61	-	2.13	-	-	.19	3.7
-	RS887	2.09	.67	.88	5/16	.38	1.25	.46	-	2.13	-	-	.25	4.5
-	RS951	2.19	2.00	1.63	3/8	.44	2.00	.72	-	4.13	-	-	.31	12.4
-	RS1113	2.06	1.27	1.25	3/8	.41	1.50	.71	-	2.50	-	-	.31	9.3
-	RS1114	2.00	2.00	1.13	3/8	.41	2.00	.85	-	3.50	-	-	.31	8.5
-	RS1116	2.00	2.00	1.13	3/8	.44	2.00	.69	-	2.88	-	-	.25	6.0
-	RS1131	3.00	1.69	1.63	1/2	.56	2.63	.69	-	5.50	-	-	.38	15.5
-	RS1539	1.98	.59	1.25	5/16	.34	1.88	.58	-	2.75	-	-	.31	7.9
-	RS2188	1.81	1.13	1.00	1/2	.56	1.75	.86	-	3.00	-	-	.31	7.9
-	RS2190	2.00	2.00	1.13	3/8	.41	2.00	.69	-	2.88	-	-	.25	7.2
-	RS4013	1.38	1.41	.81	5/16	.34	1.19	.53	-	2.50	-	-	.19	3.9
-	RS4019	1.38	1.25	.88	3/8	.41	1.50	.45	-	2.50	-	-	.25	4.7
-	RS6018	2.00	2.00	1.25	3/8	.44	2.00	.61	-	3.00	-	-	.25	6.6
-	RS6238	2.13	1.69	1.63	1/2	.56	2.63	.79	-	5.50	-	-	.38	13.3
-	RS6438	2.13	1.69	1.63	1/2	.56	2.63	.75	-	5.50	-	-	.38	14.8
A2 Figure 2														
-	RS911	2.56	2.75	1.75	1/2	.53	3.50	1.00	-	5.50	-	-	.25	10.6
-	SS922	2.88	2.75	2.50	1/2	.53	3.50	1.00	-	5.50	-	-	.25	14.6
-	SS927	2.88	2.75	2.50	1/2	.53	3.50	1.00	-	5.50	-	-	.25	13.9
-	SS933	3.00	2.75	2.88	1/2	.53	3.50	1.41	-	5.50	-	-	.31	20.7
-	RS1211	2.56	3.00	1.75	1/2	.53	6.00	1.00	-	8.00	-	-	.25	9.5
-	SS1222	2.88	3.00	2.50	1/2	.53	6.00	1.00	-	8.00	-	-	.25	12.9
A3														
ER1222	-	2.88	3.00	2.50	1/2	.53	3.00	1.00	-	8.00	-	-	.25	13.1
FR1222	-	2.88	3.00	2.50	1/2	.53	3.00	1.00	-	8.00	-	-	.25	12.9
ER1233	-	3.25	3.00	3.00	1/2	.53	3.00	1.25	-	8.00	-	-	.31	17.1
FR1233	-	3.25	3.00	3.00	1/2	.53	3.00	1.25	-	8.00	-	-	.31	17.1
E1244	-	3.75	3.00	3.63	1/2	.53	3.00	1.13	-	8.00	-	-	.38	25.8
FR1244	-	3.75	3.00	3.63	1/2	.53	3.00	1.13	-	8.00	-	-	.38	25.8
F1822	-	2.88	3.50	2.50	1/2	.53	5.50	1.00	-	14.00	-	-	.25	11.4
F1844	-	3.75	3.50	3.63	1/2	.53	5.50	1.59	-	14.00	-	-	.38	22.3
2348	-	3.13	3.25	1.25	5/8	.66	2.75	1.28	-	8.00	-	-	.38	18.1
-	RS953 ①	2.34	2.00	1.00	9/16	.53	2.00	.77	-	3.25	-	-	.38	9.9
A5														
-	SS928	-	3.38	1.00	1/2	.56	2.25	-	-	3.50	-	-	.38	9.4
-	SS942	-	3.38	1.25	1/2	.56	2.25	-	-	3.50	-	-	.38	13.3
-	SS1242	-	4.88	1.25	1/2	.56	2.25	-	-	3.50	-	-	.38	14.7

① Sidebars have .76" holes located on pitch-line midway between chain joints.
 Note: Most attachments are thru-hardened.

Engineered Steel - Attachments

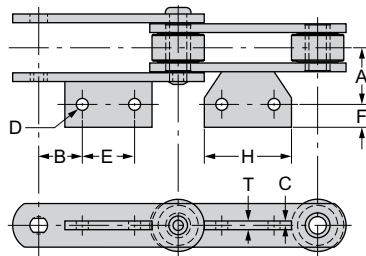

A11 Rexnord

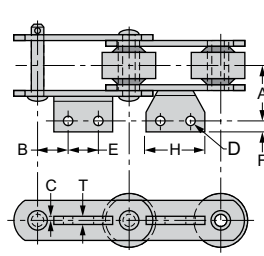

A11 Link-Belt

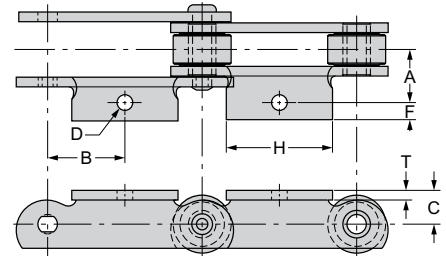

A17

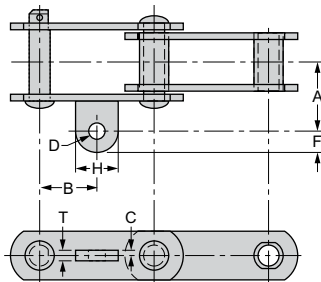

A22 Link-Belt

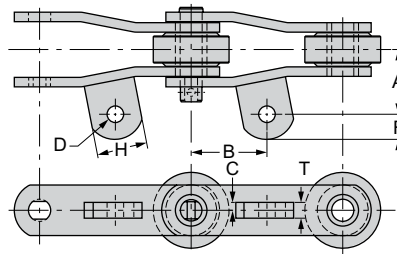

A22 Rexnord

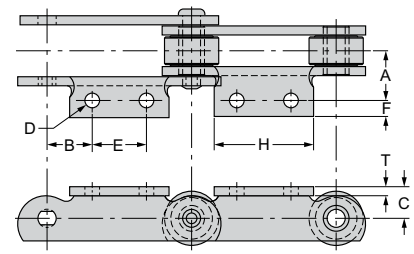

A20, A23, A25

Dimensions are in inches. Weights are in pounds.

Rexnord Chain No.	Link-Belt Chain No.	A	B	C	D		E	F	G	H	J	K	T	Wgt. Per Foot
					Bolt Dia.	Bolt Hole								
A11														
6	-	2.75	1.56	.19	1/2	.53	2.88	.84	-	4.50	-	-	.38	12.5
S951	-	2.19	2.00	.25	3/8	.41	2.25	.72	-	3.25	-	-	.25	12.0
2190	-	2.56	1.88	.19	1/4	.28	2.25	.50	-	3.25	-	-	.25	7.6
-	RS658	2.31	2.13	-	3/8	.39	1.75	.87	-	3.00	-	-	.19	12.0
-	RS2190	2.56	1.88	-	1/4	.28	2.25	.59	-	3.25	-	-	.38	7.9
-	RS6238	2.75	1.56	-	1/2	.56	2.88	1.00	-	4.50	-	-	.38	12.4
A17														
531	-	2.00	2.00	1.31	1/2	.53	-	.72	-	1.50	-	-	.38	10.0
A20														
2183	-	2.00	1.75	2.00	3/8	.41	2.50	.80	-	3.50	-	-	.31	11.7
F2183	-	2.00	1.75	2.00	3/8	.41	2.50	.63	-	3.50	-	-	.31	12.2
2190	-	2.00	2.00	1.13	3/8	.41	2.00	1.03	-	3.50	-	-	.25	7.9
A22 made also for chain with straight sidebars.														
S188	-	1.78	1.31	.08	3/8	.41	-	.59	-	1.25	-	-	.31	4.8
3420	-	2.38	2.00	.25	5/8	.69	-	.92	-	2.00	-	-	.50	9.1
A22														
-	SBS188	1.78	1.31	.19	3/8	.41	-	.59	-	1.19	-	-	.38	4.8
A23														
FR922	-	3.41	3.13	1.00	1/2	.56	2.75	.88	-	4.75	-	-	.25	13.6
FR933	-	4.13	3.13	1.25	1/2	.56	2.75	.88	-	4.75	-	-	.25	18.6
FR1244	-	4.50	3.25	1.50	5/8	.66	5.50	.88	-	7.50	-	-	.38	25.8
A25														
S951	-	3.19	2.00	1.31	1/2	.56	2.00	.75	-	3.50	-	-	.25	13.2
2183	-	2.90	2.19	1.00	3/8	.41	1.63	.67	-	3.13	-	-	.25	11.4
F2183	-	2.90	2.19	1.00	3/8	.41	1.63	.67	-	3.13	-	-	.25	12.8

Note: Most attachments are thru-hardened.

Engineered Steel - Attachments

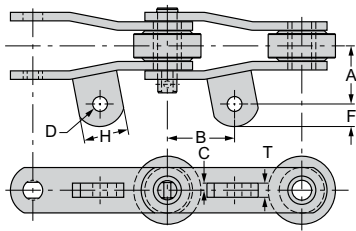

A42

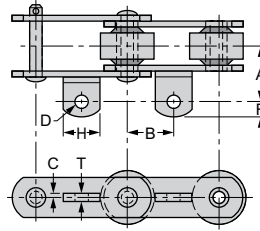

A42 Figure 1

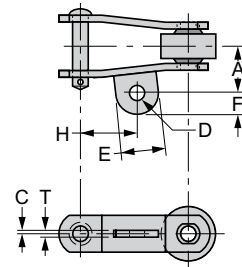

A42 Figure 2

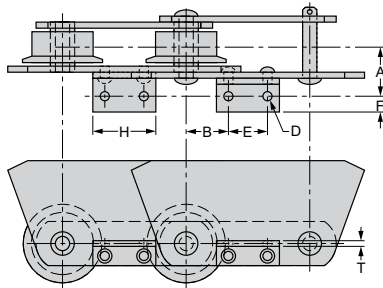

AR7

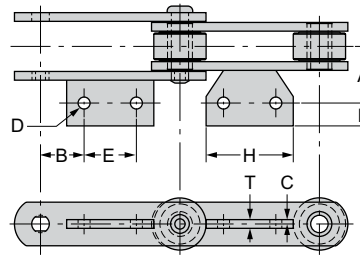

A63

Dimensions are in inches. Weights are in pounds.

Rexnord Chain No.	Link-Belt Chain No.	A	B	C	D		E	F	G	H	J	K	T	Wgt. Per Foot
					Bolt Dia.	Bolt Hole								
A42														
6	-	2.56	3.00	.31	5/8	.66	-	.86	-	2.00	-	-	.63	12.3
SR183	-	1.31	1.50	.13	5/16	.34	-	.38	-	.88	-	-	.25	4.2
SR825	-	2.75	2.13	.31	5/8	.66	-	.81	-	1.50	-	-	.63	9.4
SR830	-	2.56	3.00	.31	3/4	.78	-	1.00	-	2.00	-	-	.63	8.1
RR1120	-	1.63	2.00	.19	3/8	.41	-	.63	-	1.25	-	-	.38	3.5
RS1131	-	2.59	3.00	.31	5/8	.66	-	1.00	-	2.00	-	-	.63	13.8
1604	-	1.75	3.00	.19	3/8	.41	-	.63	-	1.25	-	-	.38	6.6
2180	-	2.69	3.00	.22	5/8	.66	-	.56	-	1.50	-	-	.44	10.2
FX2184	-	2.56	3.00	.31	5/8	.66	-	1.00	-	2.00	-	-	.63	13.5
SR3130	-	2.38	3.00	.31	5/8	.66	-	.81	-	2.00	-	-	.63	11.0
A42 Figure 1														
-	RS1113	2.38	2.02	.25	5/8	.66	-	.94	-	1.50	-	-	.50	9.1
-	RS1131	2.59	3.00	.31	5/8	.69	-	1.00	-	2.00	-	-	.63	13.8
-	RS2284	2.63	3.00	.31	5/8	.69	-	1.08	-	2.00	-	-	.63	13.1
-	RS2284+	2.63	3.00	.31	5/8	.69	-	1.08	-	2.00	-	-	.61	13.1
-	RS2600	3.75	3.00	.31	5/8	.69	-	.91	-	2.00	-	-	.61	27.7
-	RS3013	1.56	1.50	.13	3/8	.41	-	.45	-	1.25	-	-	.25	4.3
-	RS4013	1.63	2.00	.19	3/8	.41	-	.50	-	1.25	-	-	.38	3.7
-	RS6238	2.56	3.00	.31	5/8	.66	-	.81	-	2.00	-	-	.61	11.3
-	RS6438	2.56	3.00	.31	5/8	.66	-	.81	-	2.00	-	-	.61	13.0
A42 Figure 2														
-	RO2113	2.38	2.00	.25	5/8	.66	-	.75	-	1.50	-	-	.50	9.5
-	RO2284	2.63	3.00	.31	5/8	.69	-	.88	-	2.00	-	-	.63	13.1
-	RO2284+	2.63	3.00	.31	5/8	.69	-	.88	-	2.00	-	-	.63	13.1
A63														
4	-	1.63	1.25	.13	5/16	.34	1.50	.66	-	2.50	-	-	.25	4.8
AR7														
-	RS658	2.31	2.13	-	5/16	.39	1.75	.75	-	3.00	-	-	.19	18.7

Note: Most attachments are thru-hardened.
 Note: "+" sign denotes "plus".

Engineered Steel - Attachments

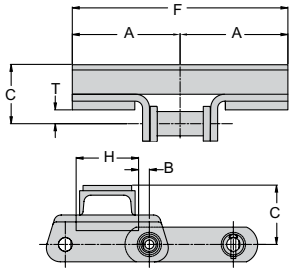

B155

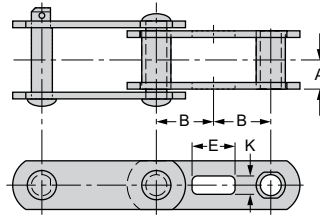

BM5, bm55

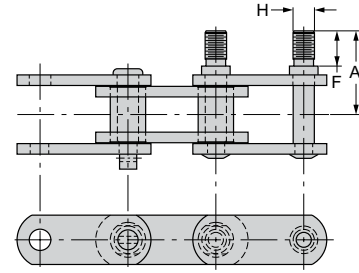

D2

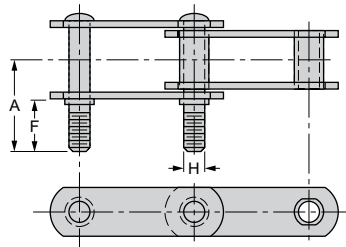

D3

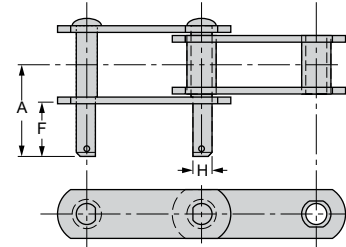

D4

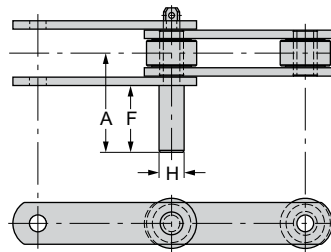

D5 Rexnord

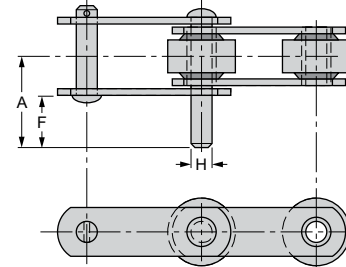

D5 Link-Belt

Dimensions are in inches. Weights are in pounds.

Rexnord Chain No.	Link-Belt Chain No.	A	B	C	D		E	F	G	H	J	K	T	Wgt. Per Foot
					Bolt Dia.	Bolt Hole								
B155														
ER150	-	-	.78	4.25	-	-	-	15.50	-	4.50	-	-	1.00	49.6
BM51														
-	SS2004	.88	1.31	-	-	-	1.28	-	-	-	-	.66	-	6.9
BM55^①														
-	SBS1972	1.13	1.88	-	-	-	1.28	-	-	-	-	.66	-	9.2
-	SBS3336	1.02	2.00	-	-	-	1.28	-	-	-	-	1.06	-	21.1
-	SS2004	.88	1.31	-	-	-	1.28	-	-	-	-	.66	-	6.9
D2														
1535	-	2.97	-	-	-	-	-	1.25	-	.75	-	-	-	8.8
D3														
-	SBS3336	3.54	-	-	-	-	-	1.44	-	.93	-	-	-	22.7
-	SBS2236	3.54	-	-	-	-	-	1.44	-	.90	-	-	-	21.0
D4														
-	SBS2162	3.15	-	-	-	-	-	.88	-	75 ^②	-	-	-	10.2
D5														
4	-	2.97	-	-	-	-	-	2.00	-	.75	-	-	-	4.9
-	RS303	2.08	-	-	-	-	-	1.44	-	.50	-	-	-	2.2
-	RS4019	2.99	-	-	-	-	-	2.00	-	.75	-	-	-	5.1

① Forged attachment sidebar on one side has slotted hole. Plain steel sidebar on opposite side.

② Steel slotted sidebars on both sides.

Note: Most attachments are thru-hardened.

Engineered Steel - Attachments

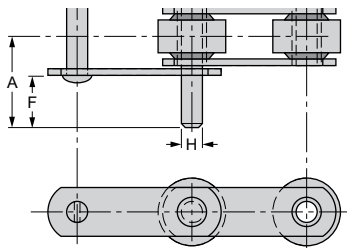

D6

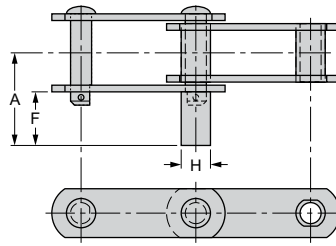

D7

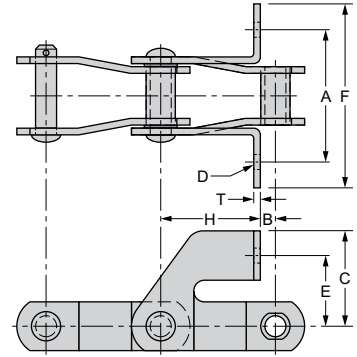

F29

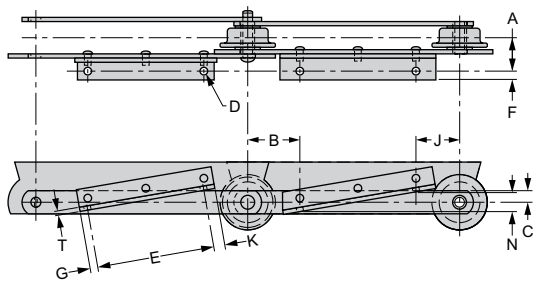

G2

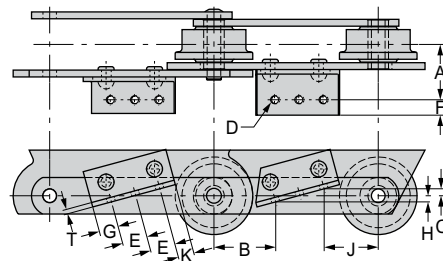

G3

Dimensions are in inches. Weights are in pounds.

Rexnord Chain No.	Link-Belt Chain No.	A	B	C	D		E	F	G	H	J	K	T	Wgt. Per Foot
					Bolt Dia.	Bolt Hole								
D6														
-	RS3013	2.39	-	-	-	-	-	1.50	-	.63	-	-	-	4.8
-	SS152	2.23	-	-	-	-	-	1.50	-	.50	-	-	-	2.4
D7														
-	SS152	2.23	-	-	-	-	-	1.50	-	.56	-	-	-	2.6
F29														
-	SB02103	3.50	.63	2.68	3/8	.44	-	4.88	-	2.45	-	-	.25	8.0
G2														
-	SS922	3.03	3.34	.81	7/16	.47	2.75	.84	.63	-	3.03	.63	.25	22.4
-	SS933	3.16	3.25	1.03	7/16	.47	2.75	.84	.63	-	3.13	.63	.25	29.6
-	SS1233	3.16	3.94	1.69	5/8	.68	4.50	.84	1.69	-	3.69	1.69	.25	21.3
G3 This attachment made with high sidebars of 3.50 to 8 inches; weights are for 6-inch bars.														
FR922	-	3.03	3.38	.39	3/8	.41	1.38	.75	1.06	.33	2.97	.88	.25	22.4
ER1233	-	3.16	3.94	.63	7/16	.47	2.25	.84	1.69	.47	3.69	1.69	.25	21.3
FR1233	-	3.16	3.94	.63	3/8	.44	2.25	.84	1.69	.47	3.69	1.69	.25	21.3

Note: Most attachments are thru-hardened.

Engineered Steel - Attachments

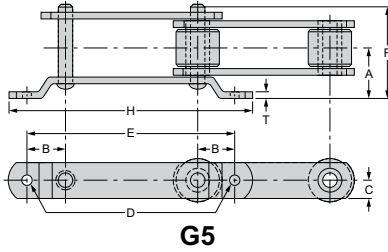

G5

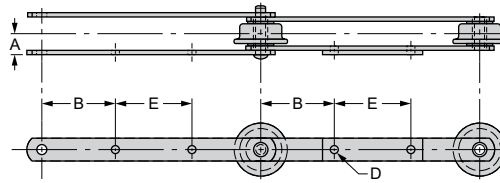

G6

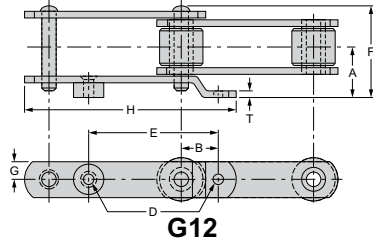

G12

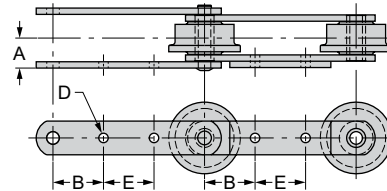

G16, G17, G18

Dimensions are in inches. Weights are in pounds.

Rexnord Chain No.	Link-Belt Chain No.	A	B	C	D		E	F	G	H	J	K	T	Wgt. Per Foot
					Bolt Dia.	Bolt Hole								
G5														
4004	-	3.34	2.50	1.25	5/8	.66	14.00	6.34	-	16.50	-	-	.50	18.5
R4009	-	3.03	2.50	1.25	5/8	.66	14.00	5.53	-	16.50	-	-	.38	14.7
4010	-	3.90	3.38	2.00	13/16	.84	18.75	7.38	-	21.25	-	-	.63	39.2
4065	-	3.94	2.50	1.75	5/8	.66	14.00	7.00	-	16.50	-	-	.63	38.6
G6														
-	RS911	1.39	3.13	-	7/16	.50	2.75	-	-	-	-	-	-	9.6
-	SS922	1.78	3.00	-	1/2	.53	3.00	-	-	-	-	-	-	13.9
-	SS927	1.78	3.00	-	1/2	.53	3.00	-	-	-	-	-	-	13.2
-	SS933	1.91	3.25	-	1/2	.53	2.50	-	-	-	-	-	-	18.1
-	SS1222	1.78	4.13	-	1/2	.53	3.75	-	-	-	-	-	-	11.6
-	SS1227	1.78	4.13	-	1/2	.53	3.75	-	-	-	-	-	-	11.8
-	SS1232	1.78	4.13	-	1/2	.53	3.75	-	-	-	-	-	-	13.0
-	SS1233	1.91	4.13	-	1/2	.56	3.75	-	-	-	-	-	-	15.4
-	SS4038	1.59	4.13	-	1/2	.53	3.75	-	-	-	-	-	-	10.1
-	RS4850	1.88	4.13	-	3/4	.78 ①	3.75	-	-	-	-	-	-	16.4
G12														
-	RS4851	3.41	2.50	-	1/2	.56	9.00	5.53	1.25	13.82	-	-	.38	14.5
-	RS4852	3.86	2.50	-	5/8	.66	9.00	3.78	1.25	13.82	-	-	.50	18.0
G16 is called G6 by some manufacturers.														
ER911	-	1.41	2.63	-	1/2	.56	3.75	-	-	-	-	-	-	9.6
ER922	-	1.78	3.00	-	1/2	.56	3.00	-	-	-	-	-	-	13.2
FR922	-	1.78	3.00	-	1/2	.56	3.00	-	-	-	-	-	-	13.9
ER933	-	1.90	3.25	-	1/2	.56	2.50	-	-	-	-	-	-	18.1
FR933	-	1.90	3.25	-	1/2	.56	2.50	-	-	-	-	-	-	18.1
E1211	-	1.41	4.13	-	1/2	.56	3.75	-	-	-	-	-	-	8.2
ER1222	-	1.78	4.13	-	1/2	.56	3.75	-	-	-	-	-	-	11.8
FR1222	-	1.78	4.13	-	1/2	.56	3.75	-	-	-	-	-	-	11.6
ER1233	-	1.90	4.12	-	5/8	.69	3.75	-	-	-	-	-	-	21.3
FR1233	-	1.90	4.13	-	1/2	.56	3.75	-	-	-	-	-	-	15.4
ER1244	-	2.34	4.13	-	5/8	.69	3.75	-	-	-	-	-	-	23.2
FR1244	-	2.34	4.13	-	5/8	.69	3.75	-	-	-	-	-	-	23.2
ER1822	-	1.78	6.00	-	1/2	.56	6.00	-	-	-	-	-	-	10.1
FR1822	-	1.78	6.00	-	1/2	.56	6.00	-	-	-	-	-	-	9.9
F1833	-	1.90	6.00	-	1/2	.56	6.00	-	-	-	-	-	-	12.8
FR1844	-	2.34	6.00	-	1/2	.56	6.00	-	-	-	-	-	-	18.8
2348	-	1.90	4.13	-	1/2	.56	3.75	-	-	-	-	-	-	16.4
G17														
ER1244	-	2.34	4.13	-	5/8	.69	3.75	-	-	-	-	-	-	23.2
FR1244	-	2.38	4.13	-	1/2	.56	3.75	-	-	-	-	-	-	21.5
G18														
FR922	-	1.78	3.13	-	1/2	.56	2.75	-	-	-	-	-	-	12.5

① Countersunk head for inside sidebar.
Note: Most attachments are thru-hardened.

Engineered Steel - Attachments

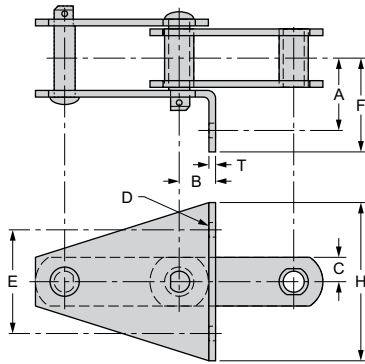

G19

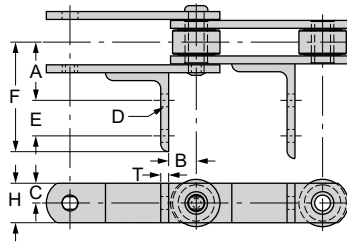

G29 Rexnord

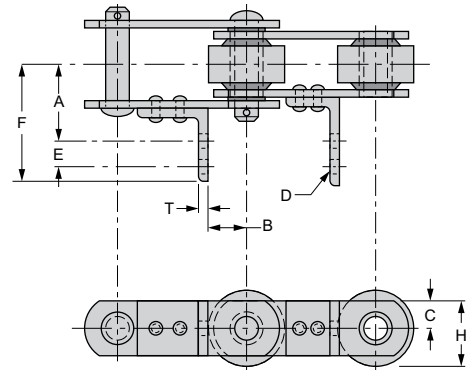

G29 Link-Belt

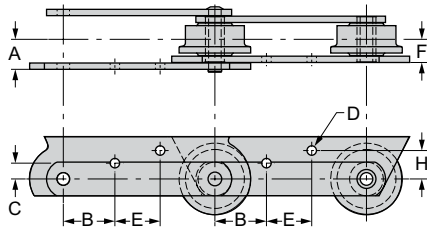

G33

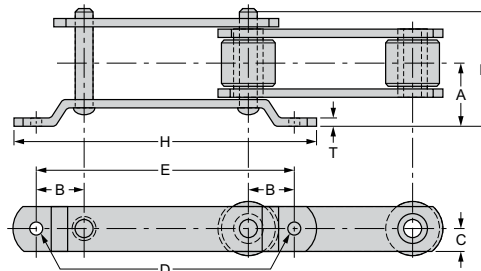

G100

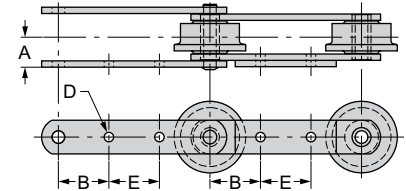

G116, G117

Dimensions are in inches. Weights are in pounds.

Rexnord Chain No.	Link-Belt Chain No.	A	B	C	D		E	F	G	H	J	K	T	Wgt. Per Foot
					Bolt Dia.	Bolt Hole								
G19														
-	SS1222	2.78	2.63	-	1/2	.53	3.50	3.78	-	5.50	-	-	.25	13.9
-	RS4328	2.63	2.50	-	1/2	.53	3.25	3.26	-	2.50	-	-	.38	14.1
-	SBS102B	3.00	1.50	-	1/2	.53	3.25	3.62	-	4.50	-	-	.38	8.9
-	SBS188	2.19	.94	-	3/8	.41	2.63	2.64	-	3.75	-	-	.25	7.5
G29 made also for inner (roller) link; "F" is 3.69".														
4	-	1.84	.88	.63	3/8	.41	1.13	3.47	-	1.25	-	-	.25	5.3
G29														
RS4019	-	1.84	3.13	.63	3/8	.44	1.13	3.70	-	1.38	-	-	.25	5.4
G33 weights are for 6-inch bars.														
FR922	-	1.78	3.06	.94	1/2	.56	2.69	1.38	-	1.69	-	-	-	22.4
ER933	-	1.90	3.06	.94	1/2	.56	2.69	1.50	-	1.69	-	-	-	25.2
FR933	-	1.90	3.06	.94	1/2	.56	2.69	1.50	-	1.69	-	-	-	25.2
G100														
-	RS4065	3.94	2.50	1.50	5/8	.69	14.00	7.44	-	-	-	-	.50	41.0
-	RS4851	3.03	2.50	1.25	5/8	.69	14.00	5.44	-	-	-	-	.38	14.7
-	RS4852	3.34	2.50	1.25	5/8	.69	14.00	6.21	-	-	-	-	.50	18.3
G116														
4011	-	1.88	4.13	-	3/4	.81	3.75	-	-	-	-	-	-	12.6
G117														
ER1244	-	2.38	4.13	-	1/2	.56	3.75	-	-	-	-	-	-	21.5
FR1244	-	2.38	4.13	-	1/2	.56	3.75	-	-	-	-	-	-	21.5
R1251	-	2.00	3.00	-	1/2	.56	4.00	-	-	-	-	-	-	9.8
R1706	-	2.56	3.00	-	1/2	.56	4.00	-	-	-	-	-	-	13.9

Ⓢ Block links only.
Note: Most attachments are thru-hardened.

Engineered Steel - Attachments

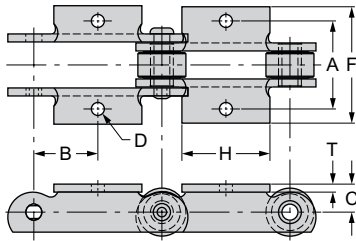

K1 Rexnord

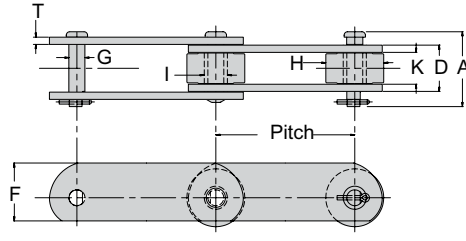

H

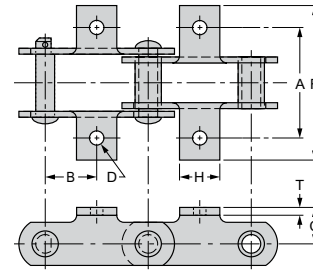

K1 Link-Belt

Dimensions are in inches. Weights are in pounds.

Rexnord Chain No.	Link-Belt Chain No.	Average Pitch	A	D	E	F	G	H	I	K	T	Wgt. Per Foot		
H														
1617	-	6.000	3.24	2.69	1.38	2.50	0.69	2.50	1.00	-	0.31	-		
1695	-	6.000	3.77	2.95	1.30	3.00	0.87	2.50	1.25	-	0.38	-		
Rexnord Chain No.	Link-Belt Chain No.	A	B	C	D		E	F	G	H	J	K	T	Wgt. Per Foot
K1														
4	-	2.75	2.00	.88	3/8	.41	-	3.81	-	2.75	-	-	.25	5.3
SR1831	-	2.94	1.50	.81	5/16	.34	-	4.03	-	2.00	-	-	.19	4.9
S188	-	3.75	1.31	.81	3/8	.41	-	5.12	-	2.12	-	-	.25	5.1
SR1881	-	3.44	2.00	1.00	3/8	.41	-	5.13	-	3.38	-	-	.19	5.9
SR1941	-	4.00	2.00	1.13	3/8	.41	-	5.25	-	3.25	-	-	.19	7.3
SR1961	-	4.00	3.00	1.25	3/8	.41	-	5.66	-	3.50	-	-	.25	7.5
RR432	-	2.75	.83	.81	1/4	.28	-	3.56	-	1.00	-	-	.19	5.7
RR588	-	3.88	1.31	.88	5/16	.34	-	5.66	-	2.13	-	-	.25	4.3
589	-	4.31	1.753	1.25	1/2	.56	-	6.38	-	2.00	-	-	.38	11.8
RR778	-	3.88	1.31	.88	5/16	.34	-	5.28	-	2.13	-	-	.19	3.0
RR1120	-	2.75	2.00	.81	3/8	.41	-	4.03	-	2.50	-	-	.19	4.0
C1288	-	3.00	1.30	.81	3/8	.41	-	4.81	-	2.13	-	-	.16	3.7
1539	-	3.75	1.53	1.25	1/2	.56	-	5.16	-	3.00	-	-	.31	9.0
2188	-	3.38	2.00	1.00	3/8	.41	-	5.44	-	2.75	-	-	.31	8.8
5208	-	6.88	3.00	1.25	3/4	.81	-	9.00	-	2.00	-	-	.38	12.6
68261	-	6.00	3.00	1.63	1/2	.56	-	7.19	-	3.88	-	-	.38	15.3
-	RS625	2.38	.83	.69	1/4	.31	-	3.44	-	.88	-	-	.13	3.4
-	RS627	2.75	.83	.81	1/4	.28	-	3.81	-	1.00	-	-	.19	5.7
-	RS944+	4.75	2.50	1.63	5/8	.69	-	6.48	-	2.50	-	-	.38	11.5
-	RS1539	3.75	1.53	1.25	1/2	.56	-	5.05	-	2.75	-	-	.31	9.0
-	RS2188	3.63	2.00	1.00	1/2	.56	-	5.33	-	3.00	-	-	.31	8.8
-	RS3013	2.94	1.50	.81	5/16	.34	-	3.79	-	2.00	-	-	.19	5.1
-	S4013	2.75	2.00	.81	3/8	.41	-	3.81	-	2.50	-	-	.19	4.4
-	S4019	2.75	2.00	.88	3/8	.41	-	4.83	-	2.50	-	-	.25	5.4
-	RS4113	3.44	2.00	1.00	3/8	.41	-	4.62	-	2.50	-	-	.19	5.2
-	S4216	4.00	2.00	1.13	3/8	.41	-	5.24	-	3.38	-	-	.19	6.3
-	RS4328	4.00	2.00	1.25	1/2	.56	-	5.75	-	2.00	-	-	.38	11.7
-	SBS188	3.75	2.00	.81	3/8	.44	-	5.16	-	2.13	-	-	.25	5.1

Notes: Most attachments are thru-hardened.
 A1/A2 and K1/K2 attachments may be combined on the same side bar.
 "+" sign denotes "plus".

Engineered Steel - Attachments

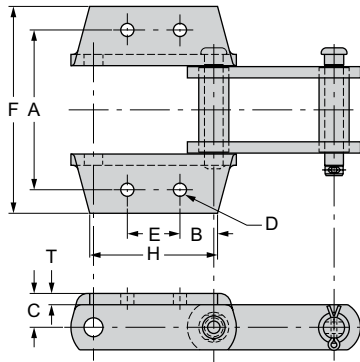

**K2 for ER102B, ER102.5, ER111,
ER111SP, SR830, and ER833**

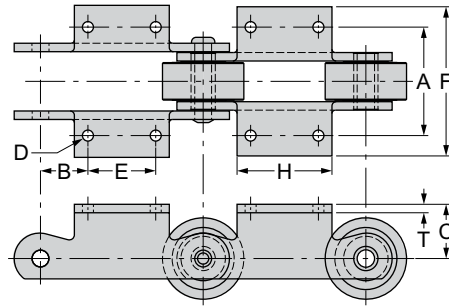

K2 for All Others

Dimensions are in inches. Weights are in pounds.

Rexnord Chain No.	Link-Belt Chain No.	A	B	C	D		E	F	G	H	J	K	T	Wgt. Per Foot
					Bolt Dia.	Bolt Hole								
K2 made also for chain with offset sidebars.														
4	-	2.75	1.25	.88	3/8	.41	1.50	3.81	-	2.75	-	-	.25	5.3
6	-	4.25	1.69	1.63	1/2	.56	2.63	5.69	-	5.50	-	-	.38	15.0
ER102B ①	-	5.31	1.13	1.13	3/8	.41	1.75	6.94	-	4.25	-	-	.38	9.0
ER102.5 ①	-	5.31	1.16	1.13	3/8	.41	1.75	6.78	-	4.56	-	-	.38	13.4
ER111 ①	-	6.25	1.22	1.50	3/8	.41	2.31	7.88	-	5.22	-	-	.38	15.2
ER111Sp ①	-	6.25	1.22	1.50	3/8	.41	2.31	7.88	-	3.63	-	-	.38	13.0
SR150	-	7.50	1.66	1.88	1/2	.56	2.75	9.81	-	4.25	-	-	.50	23.0
SR183	-	3.13	.97	.81	1/4	.28	1.06	4.00	-	2.00	-	-	.19	4.9
S188	-	4.19	.67	.81	5/16	.34	1.25	5.13	-	2.13	-	-	.25	5.8
SR188	-	4.00	.75 ⑤	1.00	3/8	.41	2.00 ⑤	5.03	-	3.38	-	-	.19	5.9
SR194	-	4.00	1.00	1.13	3/8	.41	2.00	5.25	-	3.25	-	-	.19	7.3
SR196	-	4.00	2.00	1.25	3/8	.41	2.00	5.66	-	3.50	-	-	.25	7.5
SR23 ②	-	5.25	1.44 ⑤	1.06	3/8	.41	1.69	6.88	-	2.75	-	-	.25	7.3
SR825 ②	-	6.00	.50	1.19	1/2	.56	2.63	8.88	-	3.75	-	-	.38	16.0
SR830 ④	-	6.00	1.69	1.19	1/2	.56	2.63	7.66	-	6.34	-	-	.38	12.3
ER833 ①	-	6.25	1.84	1.88	1/2	.56	2.31	8.13	-	6.94	-	-	.38	20.2
SR844 ②	-	6 & 4.9	1.56	1.19	1/2	.56	2.75	7.50	-	4.00	-	-	.50	14.9
ER911	-	5.13	2.75	1.75	1/2	.56	3.50	7.13	-	5.50	-	-	.25	12.7
ER922	-	5.75	2.75	2.50	1/2	.56	3.50	7.56	-	5.50	-	-	.25	16.0
FR922	-	5.75	2.75	2.50	1/2	.56	3.50	7.75	-	5.50	-	-	.25	16.6
ER933	-	6.50	2.75	3.00	9/16	.62	3.50	8.00	-	5.50	-	-	.38	25.2
FR933	-	6.00	2.75	2.88	1/2	.56	3.50	7.81	-	5.50	-	-	.31	22.3
S951	-	4.38	2.00	1.63	3/8	.41	2.00	6.31	-	3.50	-	-	.38	14.7
SR1114	-	4.00	2.00	1.13	3/8	.41	2.00	5.38	-	3.50	-	-	.31	10.7
RS1131	-	6.00	1.69	1.63	1/2	.56	2.63	7.38	-	4.50	-	-	.38	18.4
1539 ①	-	4.00	.59	1.25	5/16	.34	1.88	5.16	-	3.00	-	-	.31	9.0
C2124 ③	-	4.38	1.50	1.63	1/2	.56	3.00	5.25	-	4.50	-	-	.38	15.8
A2124 ③	-	4.38	1.50	1.63	1/2	.56	3.00	5.25	-	4.50	-	-	.38	15.8
2126	-	4.00	2.00	1.13	3/8	.41	2.00	6.06	-	3.50	-	-	.25	7.0
A2178 ③	-	4.38	1.50	1.63	1/2	.56	3.00	5.62	-	4.50	-	-	.38	15.3
2180	-	4.75	2.00	1.63	1/2	.56	2.00	6.22	-	3.50	-	-	.38	11.7
2188	-	3.63	1.13	1.00	1/2	.56	1.75	5.44	-	2.75	-	-	.31	8.8
A2198	-	4.38	1.50	1.63	1/2	.56	3.00	6.00	-	4.50	-	-	.50	18.2
2858 ④	-	5.38	1.16	2.00	5/8	.69	1.75	6.75	-	6.38	-	-	.38	18.0
A2868	-	5.50	1.13	1.63	1/2 ⑤	.56	1.75	7.00	-	5.75	-	-	.38	14.1
3285 ④	-	6.50	1.00	2.06	3/4	.81	2.50	8.25	-	7.00	-	-	.50	40.0
3420	-	4.13	1.27	1.25	3/8	.41	1.50	6.13	-	2.75	-	-	.31	11.0
6826	-	6.00	1.69	1.63	1/2	.56	2.63	7.19	-	3.88	-	-	.38	15.3
7539 ④	-	4.13	.81	1.13	1/2	.56	1.50	5.78	-	4.72	-	-	.31	21.0

① A1/A2 and K1/K2 attachments may be combined on the same side bar.
 ② Full width attachment cannot be coupled consecutively.
 ③ These chains have offset sidebars.
 ④ Lower edge of sidebar is necked.
 ⑤ Not Central.
 Note: Most attachments are thru-hardened.

Engineered Steel - Attachments

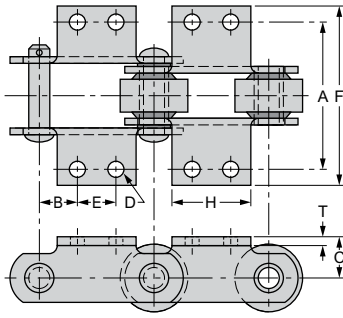

K2 Figure 1

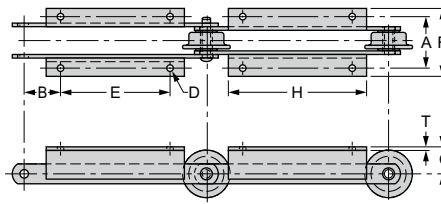

K2 Figure 2

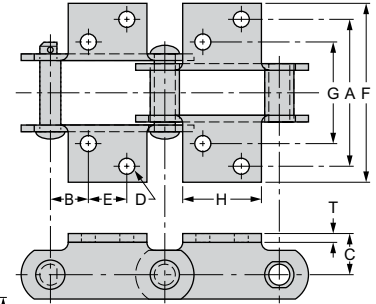

K2 Figure 3

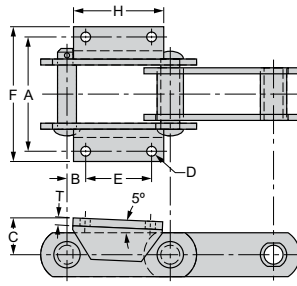

K2 Figure 4

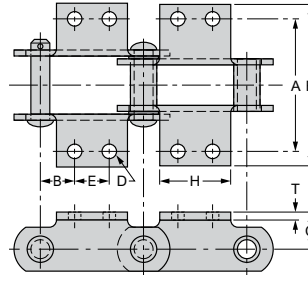

K2 Figure 5

Dimensions are in inches. Weights are in pounds.

Rexnord Chain No.	Link-Belt Chain No.	A	B	C	D		E	F	G	H	J	K	T	Wgt. Per Foot
					Bolt Dia.	Bolt Hole								
K2 Figure 1														
-	RS658	5.25	1.50	2.50	3/8	.44	3.00	6.83	-	4.38	-	-	.31	14.9
-	RS886	4.19	.67	.81	5/16	.34	1.25	5.40	-	2.13	-	-	.19	4.6
-	RS887	4.19	.67	.88	5/16	.38	1.25	5.10	-	2.13	-	-	.25	5.6
-	S951	4.38	2.00	1.63	3/8	.44	2.00	5.80	-	4.13	-	-	.31	14.3
-	S960	4.38	1.50	1.63	1/2	.56	3.00	6.04	-	4.38	-	-	.50	18.2
-	S996	4.38	1.50	1.63	1/2	.56	3.00	5.72	-	5.50	-	-	.38	15.8
-	S1113	4.12	1.27	1.25	3/8	.41	1.50	5.55	-	2.50	-	-	.31	11.0
-	RS1114	4.00	2.00	1.13	3/8	.41	2.00	5.69	-	3.50	-	-	.31	10.7
-	RS1116	4.00	2.00	1.13	3/8	.44	2.00	5.38	-	2.88	-	-	.25	7.0
-	RS1131	6.00	1.69	1.63	1/2	.56	2.63	7.38	-	5.50	-	-	.38	18.4
-	RS1539	3.97	.60	1.25	5/16	.34	1.88	5.13	-	2.75	-	-	.31	9.0
-	S1796	4.38	1.50	1.63	1/2	.56	3.00	5.73	-	4.38	-	-	.38	15.3
-	RS2047	4.38	1.50	1.75	1/2	.53	3.00	6.70	-	4.38	-	-	.38	32.0
-	RS2188	3.62	1.13	1.00	1/2	.56	1.75	5.33	-	3.00	-	-	.31	8.8
-	S4013	2.75	1.41	.81	5/16	.34	1.19	3.81	-	2.50	-	-	.19	4.4
-	RS4019	2.75	1.25	.88	3/8	.41	1.50	3.77	-	2.50	-	-	.25	5.3
-	RS6018	4.00	2.00	1.25	3/8	.44	2.00	5.23	-	3.00	-	-	.25	6.2
-	RS6238	4.25	1.69	1.63	1/2	.56	2.63	5.75	-	5.50	-	-	.38	15.8
K2 Figure 2														
-	RS911	5.13	2.75	1.75	1/2	.53	3.50	7.13	-	5.50	-	-	.25	12.7
-	SS922	5.75	2.75	2.50	1/2	.53	3.50	7.75	-	5.50	-	-	.25	16.6
-	SS927	5.75	2.75	2.50	1/2	.53	3.50	7.75	-	5.50	-	-	.25	16.0
-	SS933	6.00	2.75	2.88	1/2	.53	3.50	8.82	-	5.50	-	-	.31	22.3
-	S1211	5.13	3.00	1.75	1/2	.53	6.00	7.13	-	8.00	-	-	.25	11.7
-	SS1222	5.75	3.00	2.50	1/2	.53	6.00	7.75	-	8.00	-	-	.25	15.2
-	SS1233	6.00	3.00	2.88	1/2	.53	6.00	8.82	-	8.00	-	-	.31	20.3
K2 Figure 3														
-	SBS844	6.00	1.63	1.50	1/2	.56	2.75	8.00	-	4.00	-	-	.50	14.9
K2 Figure 4														
-	SBS4871	8.00	1.48	2.00	3/4	.81	6.00	10.44	-	8.00	-	-	.38	20.2
K2 Figure 5														
-	SBS102B	5.32	1.13	1.00	3/8	.41	1.75	6.76	-	2.85	-	-	.38	9.0
-	SBS110	5.32	2.13	1.00	3/8	.41	1.75	7.07	-	2.88	-	-	.38	8.6
-	SBS111	6.25	1.22	1.50	1/2	.53	2.31	8.28	-	3.62	-	-	.38	15.2
-	SBS131	4.12	.79	1.00	1/2	.53	1.50	5.44	-	2.62	-	-	.38	10.2
-	SBS150+	7.50	1.65	1.88	1/2	.53	2.75	10.06	-	4.25	-	-	.50	23.0
-	SBS188	4.19	.68	.81	5/16	.34	1.25	5.22	-	2.13	-	-	.25	5.8
-	SBX856	6.31	1.88	1.88	1/2	.53	2.25	9.27	-	4.25	-	-	.50	23.0

Notes: Most attachments are thru-hardened.
 "+" denotes "plus".

Note: Dimensions are subject to change. Certified dimensions of ordered material are furnished upon request.

Engineered Steel - Attachments

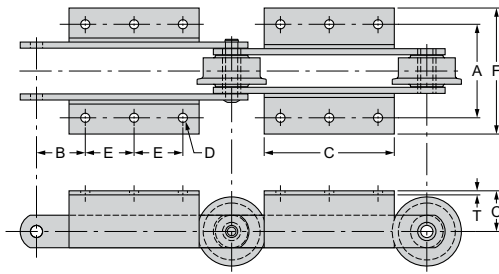

K3 Rexnord

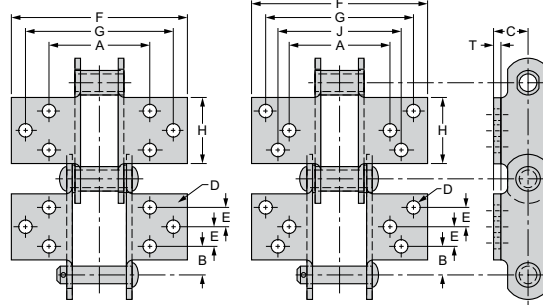

K3 Link-Belt

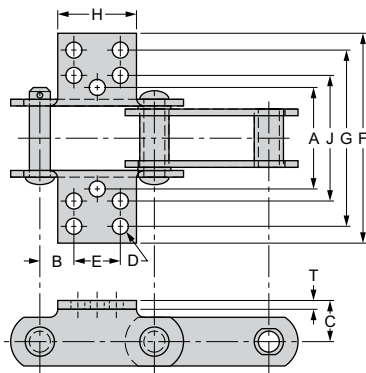

K6

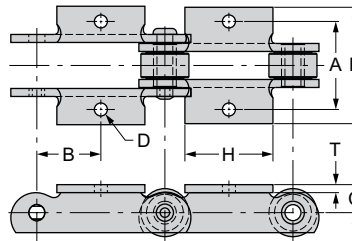

K3 on RS856 and SX150

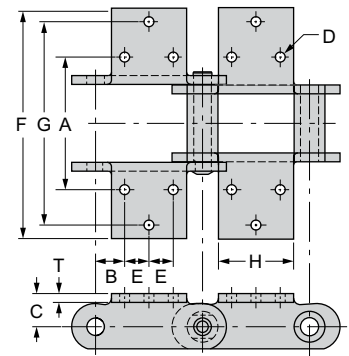

K11 and K17

Dimensions are in inches. Weights are in pounds.

Rexnord Chain No.	Link-Belt Chain No.	A	B	C	D		E	F	G	H	J	K	T	Wgt. Per Foot
					Bolt Dia.	Bolt Hole								
K3														
ER150	-	7.50	1.66	1.88	1/2	.56	1.38	13.06	11.50	4.25	-	-	.50	26.2
ER856	-	6.56	1.63	1.88	1/2	.56	1.38	13.56	10.94	5.84	-	-	.50	26.9
E1211	-	5.13	3.00	1.75	1/2	.56	3.00	7.13	-	8.00	-	-	.25	11.7
ER1222	-	5.75	3.00	2.50	1/2	.56	3.00	7.75	-	8.00	-	-	.25	15.4
FR1222	-	5.75	3.00	2.50	1/2	.56	3.00	7.75	-	8.00	-	-	.25	15.2
ER1233	-	6.50	3.00	3.00	1/2	.56	3.00	9.00	-	8.00	-	-	.31	20.3
FR1233	-	6.50	3.00	3.00	1/2	.56	3.00	9.00	-	8.00	-	-	.31	20.3
ER1244	-	7.50	3.00	3.63	1/2	.56	3.00	9.75	-	8.00	-	-	.38	30.4
FR1244	-	7.50	3.00	3.63	1/2	.56	3.00	9.75	-	8.00	-	-	.38	30.4
FR1822	-	5.75	3.50	2.50	1/2	.56	5.50	7.75	-	14.00	-	-	.25	14.1
FR1844	-	7.50	3.50	3.63	1/2	.56	5.50	10.69	-	14.00	-	-	.38	29.0
-	SBS150+	7.50	1.65	1.88	1/2	.56	1.34	13.59	11.50	4.25	-	-	.50	26.9
-	SBX856	6.56	1.63	1.88	1/2	.56	1.38	13.27	12.06	4.25	10.98	-	.50	27.3
K6														
-	SBX 856	6.56	1.62	1.88	1/2	.56	2.76	10.94	10.94	4.25	6.94	-	.50	27.3
K11														
BR2111	-	4.75	3.50	1.63	5/8	.69	-	6.88	-	3.00	-	-	.38	9.58
K17														
531	-	4.00	2.00	1.31	1/2	.56	-	5.44	-	1.50	-	-	.38	10.6

Notes: Most attachments are thru-hardened.
 Full width attachment cannot be coupled consecutively.
 "+" sign denotes "plus".

Engineered Steel - Attachments

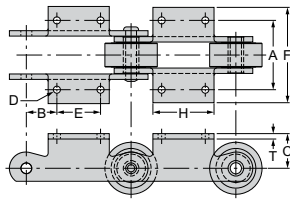

K24 Rexnord
K20, K22, K23, K25

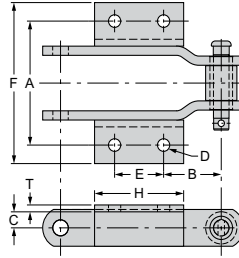

K21

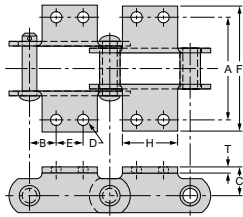

K24 Link-Belt

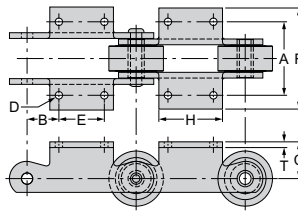

K26, K27 and K32

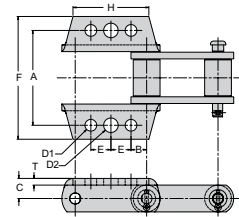

K33

Dimensions are in inches. Weights are in pounds.

Rexnord Chain No.	Link-Belt Chain No.	A	B	C	D		E	F	G	H	J	K	T	Wgt. Per Foot
					Bolt Dia.	Bolt Hole								
K20														
2183	-	4.00	1.75	2.00	3/8	.41	2.50	5.69	-	3.50	-	-	.31	13.7
F2183	-	4.00	1.75	2.00	3/8	.41	2.50	5.69	-	3.50	-	-	.31	14.9
K21														
R2342	-	6.75	3.13	1.25	5/8	.69	2.75	8.38	-	5.00	-	-	.38	15.8
K22														
ER102.5	-	5.31	1.14	1.13	1/2	.56	1.75	6.78	-	4.56	-	-	.38	14.5
ER102B	-	5.31	1.13	1.13	1/2	.56	1.75	6.94	-	4.25	-	-	.38	9.0
ER111	-	6.25	1.22	1.50	1/2	.56	2.31	7.69	-	5.22	-	-	.38	15.2
RR542	-	5.38	2.13	1.00	1/2	.56	1.75	6.81	-	7.50	-	-	.31	6.5
S188	-	3.63	.69	.81	5/16	.34	1.25	5.13	-	2.13	-	-	.25	5.8
ER833	-	5.75	1.25	1.88	1/2	.56	3.50	7.19	-	7.44	-	-	.38	20.2
A2800	-	5.19	2.38	2.19	5/8	.69	3.25	7.18	-	5.00	-	-	.50	26.2
K23														
ER856	-	6.31	1.88	1.88	1/2	.56	2.25	9.50	-	6.91	-	-	.50	21.0
K24														
ER856	-	7.25	1.75	1.88	5/8	.69	2.50	9.38	-	6.91	-	-	.50	27.5
ER956	-	7.25	1.75	1.88	5/8	.69	2.50	9.50	-	6.91	-	-	.50	29.0
1670	-	4.06	2.00	1.38	3/8	.41	2.00	5.31	-	3.50	-	-	.31	11.2
C2848	-	5.38	1.13	2.00	5/8	.69	1.75	7.13	-	6.06	-	-	.38	15.3
3285	-	6.50	1.00	2.06	3/4	.81	2.50	8.25	-	7.00	-	-	.50	23.0
A4539	-	4.13	.78	1.13	1/2	.56	1.50	5.53	-	4.56	-	-	.31	10.0
-	SBX856	7.25	1.75	1.88	5/8	.69	2.50	9.27	-	4.25	-	-	.50	23.0
K25														
ER110	-	5.31	2.13	1.13	3/8	.41	1.75	6.44	-	3.50	-	-	.38	8.6
ER131	-	4.13	.78	1.13	1/2	.56	1.50	5.59	-	2.50	-	-	.38	10.2
ER922	-	5.75	3.00	1.63	1/2	.56	3.00	7.56	-	5.00	-	-	.25	14.9
A2124 ①	-	4.88	1.75	1.63	1/2	.56	2.50	6.50	-	4.50	-	-	.38	16.8
A2178 ①	-	4.88	1.75	1.63	1/2	.56	2.50	6.50	-	4.50	-	-	.38	16.3
A2198 ①	-	4.88	1.75	1.63	1/2	.56	2.50	6.50	-	4.50	-	-	.50	19.2
K26														
ER3433 ②	-	5.31	1.13	1.13	1/2	.56	1.75	6.94	-	4.25	-	-	.38	11.1
K27														
ER833	-	6.00	1.69	1.88	1/2	.56	2.63	6.13	-	7.16	-	-	.38	20.2
K32														
R2823	-	5.25	.06	1.00	3/8	.41	1.69	6.25	-	2.75	-	-	.25	5.9
K33														
ER3433	-	5.31	.88	1.13	13/16	.66	1.13	6.88	-	4.25	-	-	.38	11.1

① Full width attachment cannot be coupled consecutively.

② Lower edge of sidebar is necked.

Notes: Most attachments are thru-hardened.

Full width attachment on outside only.

Engineered Steel - Attachments

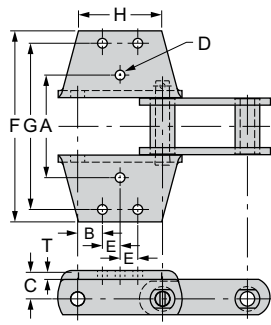

K35 Rexnord

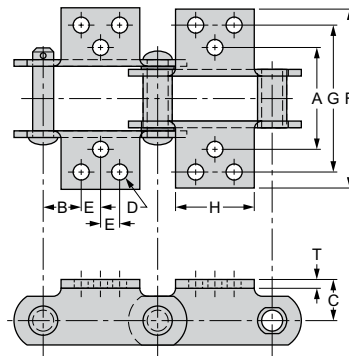

K35 Link-Belt

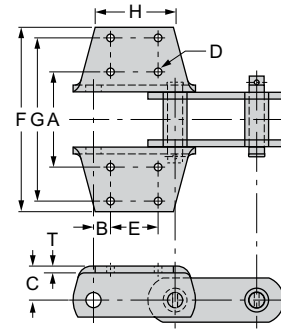

**K44 Rexnord
for ER857 and ER958**

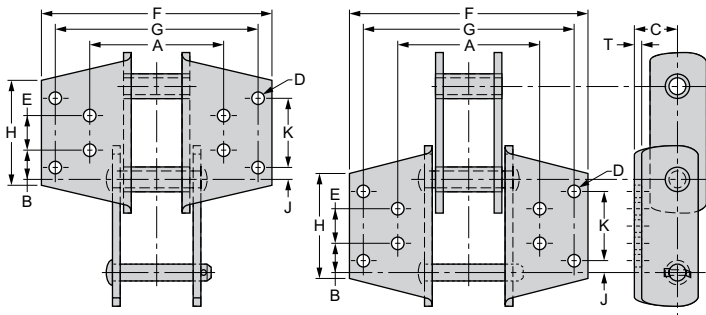

K44 Rexnord for ER859

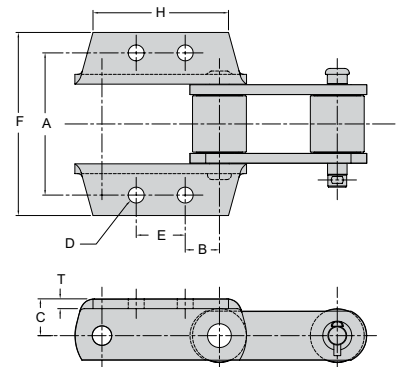

K44 Rexnord for B9856

Dimensions are in inches. Weights are in pounds.

Rexnord Chain No.	Link-Belt Chain No.	A	B	C	D		E	F	G	H	J	K	T	Wgt. Per Foot
					Bolt Dia.	Bolt Hole								
K35														
ER856	—	7.25	1.75	1.88	5/8	.69	1.25	13.56	11.75	5.84	—	—	.50	26.9
—	SBX856	7.50	1.75	1.88	5/8	.69	1.25	13.27	11.75	4.25	—	—	.50	27.3
8 Holes – K44														
ER857	—	7.00	1.25	2.50	1/2	.56	3.50	14.00	12.00	5.50	1.25	3.50	.50	38.0
ER859	—	9.00	1.63	3.00	5/8	.69	2.75	15.00	13.00	5.92	.75	4.50	.63	59.0
ER958	—	7.00	1.25	2.50	1/2	.56	3.50	13.68	12.00	5.75	1.25	3.50	.50	40.0
K44														
—	SBX2857	7.00	1.25	2.50	1/2	.56	3.50	13.50	12.00	5.31	1.25	—	.50	42.0
—	SBX2859	9.00	1.63	3.00	5/8	.69	2.75	14.82	13.00	5.87	.75	4.51	.63	59.3
B9856	—	7.25	1.75	1.88	13/16	.93	2.50	9.50	—	6.00	—	—	.63	59.0

Notes: Most attachments are thru-hardened.
Full width attachment cannot be coupled consecutively.

Engineered Steel - Attachments

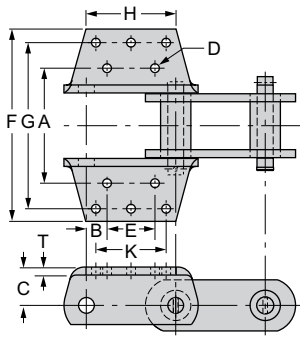

K443 Rexnord

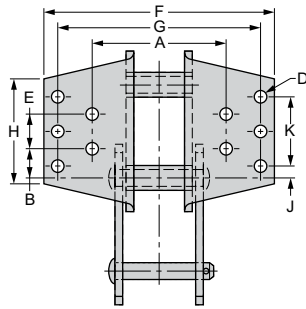

K443 Link-Belt

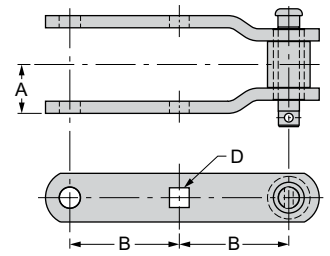
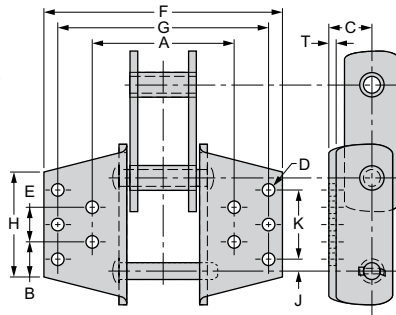

M14

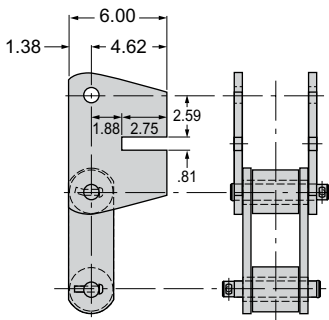

M2

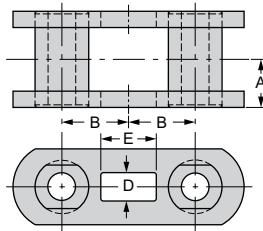

M6

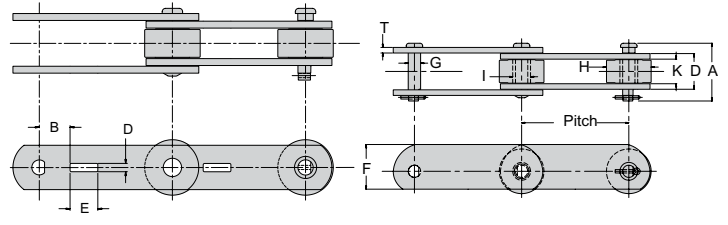

MM1

M3 & M4

Dimensions are in inches. Weights are in pounds.

Rexnord Chain No.	Link-Belt Chain No.	Average Pitch	A	D	E	F	G	H	I	K	T	Wgt. Per Foot		
M3, M4														
SR183	-	3.000	2.24	1.82	0.97	1.50	0.44	1.50	0.62	-	0.19	-		
SR194	-	4.000	2.45	1.78	1.16	2.00	0.44	2.00	0.63	-	0.19	-		
Rexnord Chain No.	Link-Belt Chain No.	A	B	C	D		E	F	G	H	J	K	T	Wgt. Per Foot
10 Holes - K443														
ER864	-	9.00	1.63	3.00	5/8	.69	3.75	15.00	13.00	7.00	.75	5.50	.63	55.0
ER984	-	9.00	1.62	3.00	5/8	.69	3.75	14.88	13.00	7.32	.75	5.50	.62	58.0
-	SBX2864	9.00	1.63	3.00	5/8	.69	3.75	15.04	13.00	6.88	.75	5.50	.63	56.7
M2														
C9856	-	Refer to Drawing for Dimensions												
MM1														
404	-	1.23	4.00	-	-	-	1.32	-	-	-	-	0.29	-	-
415	-	1.50	6.00	-	-	-	1.62	-	-	-	-	0.04	-	-
M6/M06														
270	-	.88	1.31	-	21/32	Slots	1.28	-	-	-	-	-	-	6.4
1536	-	1.11	1.53	-	21/32	Slots	1.28	-	-	-	-	-	-	8.7
7774	-	.88	1.30	-	21/32	Slots	1.28	-	-	-	-	-	-	6.8
M14														
1036	-	1.39	3.00	-	9/16	Slots	-	-	-	-	-	-	-	4.7
1039	-	1.39	4.50	-	9/16	Slots	-	-	-	-	-	-	-	4.2
R2342	-	2.00	4.50	-	3/4	Slots	-	-	-	-	-	-	-	9.0
RR2397	-	1.90	6.00	-	7/8	Slots	-	-	-	-	-	-	-	9.3
R2405	-	2.00	4.50	-	7/8	Slots	-	-	-	-	-	-	-	9.4
R2614	-	2.66	6.00	-	1 1/4	Slots	-	-	-	-	-	-	-	23.4

① Full width attachment on outside only.
Note: Most attachments are thru-hardened.

Drive Chains

Engineered Steel Drive Chains

Designed to give you superior performance, even under the most punishing conditions

Rugged, all-steel Rexnord and Link-Belt drive chains are built to perform at levels other drive chains can't match. Rexnord began manufacturing drive chain in the late 1800's and has been a leader in drive chain innovation since. Today's chains are a product of over a century of improved product design, testing and application experience. No one else in the industry comes close to our level of expertise.

More built-in features for your money

- Engineered interference fit construction designed to increase chain fatigue life and wear life.
- State-of-the-art heat treatment of all chain components to assure longer chain life. Rexnord has developed most of its own heat treating equipment in-house for better control and to precisely fit the heat treat needs of drive chain pins and bushings.
- Pins, bushings and rollers are manufactured to exact tolerances. Sidebars and sidebar holes are punched using the latest punch press technology to give superior fit and finish.
- Selectively Induction Hardened (SIH) pins, available in many of our drive chains, afford you unmatched toughness and wear resistance. Ideal for tough, shock loaded applications.
- Stocked in the largest network of warehouses in the industry. All backed up with extensive engineering and sales support.



*Smooth and precise, yet rugged.
Our drive chains are able to
handle applications from 1 to 300
plus horsepower.*

Drive Chains

Wear life is directly affected by the hardness and case depth of the wearing components

- Selectively Induction Hardened pins (the pin with the crescent-shaped hardened area) are heat treated only on the portion of the pin that experiences wear. The balance of the pin is left in a tough state to withstand shock loading.
- Chain rollers, sidebars and bushings are all heat treated for wear resistance and strength.
- Pins hardened by Rexnord's advanced induction hardening process feature extremely hard wear surfaces and deep case depths as shown below.

Ideal replacement for gearing, multiple strand roller chain, and belt drives.

- Requires less precision and expense than gearing as center distances are more flexible and adjustable.
- A single strand of Rexnord or Link-Belt drive chain can frequently replace multiple strand roller chain drives, thus simplifying maintenance. And unlike multiple strand chains, our drive chains run on simple flame-cut sprockets.
- Easily adjustable. The offset link design allows one link at a time to be taken out or inserted. No special connector links are required.
- Lower overhung loads than belt drives due to the elimination of pre-tensioning.

Rexnord chains run best on Rexnord sprockets

Although our drive chains may be run on commonly available flame cut sprockets, they give better long term performance when matched with our sprockets. Our sprockets are flame cut and induction hardened to give hard, deep case depths.

Most competitive sprockets have only a fraction of the case depth. Once the case depth is worn through, sprocket wear is rapid and chain interaction is affected, thus causing greater chain stress.



CIH pins (right and bottom) offer very hard and deep case depths around the full circumference of the pin. SIH pins (upper left) are hardened only on the load bearing surface so shock can be better absorbed by the back of the pin.



Proprietary induction hardening process gives every heat treated sprocket superior case depths and hardness.

Drive Chains

3100 Series Drive Chains

Longer life and durability than their ANSI roll equivalents

The 3100 Series drive chains are designed with all the features of our standard drive chains. But, unlike the others, they operate on standard ANSI roller chain sprockets. They may also be used to replace ANSI roller chains of the same pitch.



The 3100 Series chains handle the misalignment and contamination found in industrial applications better than roller chain.

Drive Chains

Drivemaster® Assembly Tool

The quick and safe way to assemble and disassemble Rexnord or Link-Belt drive chain

Easily assemble and disassemble our drive chains with this portable tool. An optimum amount of interference fit has been used to assemble this chain at the factory – Drivemaster allows you to maintain this optimum press fit in the field.

- Specify the chain or chains to be assembled and disassembled.
- Each Drivemaster comes with one adapter set to accept the chain or chains you specify when ordering the unit. Different chains require different adapter sets.
- Drivemaster can accept many other Rexnord chains such as welded steel and general engineered class chains. Again, specify the type of chains you anticipate working with.

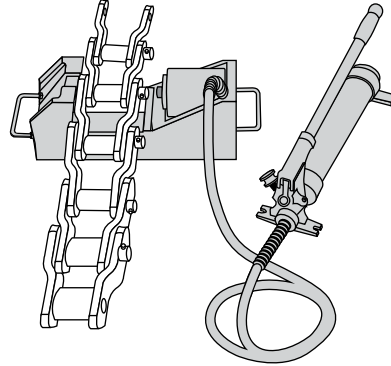

Easy-to-use Drivemaster assembly tool reduces down-time, maintains interference fit and eliminates cumbersome assembly/disassembly methods.

Application Assistance and Wear Analysis

Rexnord engineers are always available for drive chain selection and application consultation.

Rexnord also provides drive chain wear and failure analysis. This service is designed to help you get the most out of your Rexnord or Link-Belt chains.

Direction of Travel

The general rule for direction of chain to travel for offset drive chains is as follows: the narrow or roller end of the link in the tight side strand should always face the smaller sprocket, regardless of whether this is a driver or driven.



Drive Chains

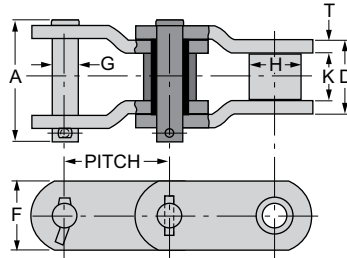

OFFSET

Properties

- TH Thru-Hardened
- CARB Carburized
- CIH Circumferentially Induction Hardened
- SIH Selectively Induction Hardened

Dimensions are in inches. Strengths, loads and weights are in pounds.

Rexnord Chain No.	Link-Belt Chain No. ①	Average Pitch	Rated Working Load	Minimum Ultimate Strength, Lbs. x 10 ³	Over-All Width		Sidebars ^③		Pins			Roller Diameter ^④	Between Sidebars K	Average Weight Per Foot	Sprocket Unit No. ⑤
					A	D	Thickness T	Height F	Diam. G	Properties	H				
Offset Sidebar Drive Chains															
R362	ROA620	1.654	1,650	14	2.03	1.25	0.13	1.13	0.38	CARB	0.88	0.97	2.0	62	
R432	ROA622	1.654	2,100	19	2.28	1.38	0.19	1.13	0.44	TH	0.88	0.97	3.5	62	
R3112	–	2.000	3,400	38	2.91	1.75	0.25	1.63	0.56	TH	1.13	1.22	6.4	3112	
B3113	ROA3160S	2.000	3,900	44	3.13	1.88	0.31	1.63	0.59	TH	1.13	1.19	7.3	3112	
R506	RO770 ^⑥	2.300	1,600	10	2.09	1.25	0.16	1.00	0.38	CARB	0.75	0.88	2.2	506	
R514	ROA2010	2.500	4,650	57	3.50	2.13	0.31	1.63	0.63	SIH	1.25	1.44	7.8	514	
A520	–	2.563	2,700	24	2.69	1.56	0.25	1.25	0.50	CARB	1.13	1.00	4.5	520	
B578	RO578 ^⑥	2.609	1,800	10	2.27	1.38	0.16	1.00	0.38	CARB	0.88	1.03	2.3	78	
R778	ROA881	2.609	2,300	18	2.41	1.50	0.19	1.13	0.44	CARB	0.88	1.06	2.3	78	
R588	ROA882	2.609	2,450	19	2.67	1.63	0.25	1.13	0.44	CARB	0.88	1.06	3.8	78	
B508H	–	2.620	2,400	19	2.63	1.56	0.25	1.13	0.44	CARB	1.00	1.06	3.8	508	
AX1568	ROA2512	3.067	6,000	77	3.90	2.31	0.38	2.25	0.75	SIH	1.63	1.50	12.1	1568	
1030	ROA40	3.075	4,650	27	3.50	2.13	0.31	1.50	0.63	CARB	1.25	1.44	6.8	1030	
R1033	ROA1031	3.075	4,650	39	3.50	2.13	0.31	1.50	0.63	SIH	1.25	1.44	6.8	1030	
R1035	ROA1032	3.075	4,650	52	3.50	2.13	0.31	1.63	0.63	SIH	1.25	1.44	7.2	1030	
R1037	ROA40 Hyper	3.075	5,100	57	3.75	2.25	0.38	1.75	0.65	SIH	1.25	1.44	8.6	1030	
Champ. 3	–	3.075	5,100	57	3.85	2.25	0.38	1.69	0.65	SIH	1.25	1.44	8.3	1030	
RO-6706	–	3.075	9,000	60	4.55	2.94	0.38	2.00	0.88	CIH	1.75	2.19	14.0	R06706	
3125	ROA3125 Hyper	3.125	6,600	84	4.00	2.38	0.38	2.25	0.80	SIH	1.63	1.56	12.3	3125	
3125-2	ROA3125-2 Hyper	3.125	13,200	168	7.19	2.38	0.38	2.25	0.80	TH	1.63	1.56	24.6	D31	
RX238	ROA2814	3.500	7,600	106	4.50	2.50	0.50	2.25	0.88	SIH	1.75	1.44	15.8	238	
AX1338	–	3.625	9,200	124	4.98	2.81	0.56	2.50	0.94	SIH	2.13	1.63	20.6	AX1338	
RO-6214	–	4.000	16,400	125	5.68	3.75	0.50	2.75	1.25	SIH	2.25	2.75	25.0	R06214	
A1236	–	4.063	6,000	73	3.91	2.31	0.38	2.00	0.75	SIH	1.75	1.56	10.4	A1236	
1240	ROA124	4.063	9,000	51	4.88	2.94	0.50	2.00	0.88	CIH	1.75	1.88	12.3	1240	
1244	–	4.063	9,000	91	4.88	2.94	0.50	2.13	0.88	SIH	1.75	1.88	13.0	1240	
R1248	ROA1242	4.063	9,000	102	4.88	2.94	0.50	2.25	0.88	SIH	1.75	1.88	15.7	1240	
RX1245	ROA3315	4.073	10,000	124	5.19	3.06	0.56	2.38	0.94	SIH	1.78	1.88	18.7	1240	
X1343	–	4.090	10,700	137	5.25	3.06	0.56	2.75	1.00	SIH	1.88	1.88	21.5	X1343	
X1345	–	4.090	10,700	137	5.25	3.06	0.56	2.75	1.00	TH	2.00	1.88	22.8	X1345	
X1351	–	4.125	12,500	166	5.38	3.19	0.56	2.75	1.13	SIH	2.25	2.00	24.8	X1351	
RO635	ROA3618	4.500	12,200	171	5.38	3.19	0.56	3.00	1.10	CIH	2.25	2.00	22.0	635	
A1204	–	5.000	13,500	169	5.63	3.44	0.56	3.00	1.13	TH	2.50	2.25	25.5	1204	
RO1205	–	5.000	16,400	196	5.93	3.75	0.56	3.25	1.25	CIH	2.50	2.56	28.5	1207	
RX1207	ROA4020	5.000	17,500	223	6.31	4.00	0.63	3.50	1.25	SIH	2.50	2.69	34.0	1207	
RO1315	ROA5035	5.000	20,000	250	6.63	4.06	0.75	3.50	1.38	CIH	2.50	2.50	37.0	RO1315	
RO1355	–	5.000	20,400	250	6.81	4.25	0.75	3.75	1.38	CIH	2.75	2.69	43.6	RO1355	
RO1356	RO5542	5.500	23,600	300	7.25	4.50	0.75	4.00	1.50	CIH	3.00	2.94	45.6	RO1356	
1301	ROA5738 ^⑥	5.750	23,000	299	7.09	4.38	0.69	4.00	1.50	TH	3.00	2.94	45.0	1301	
RO1306/ ROS1306 ^⑦	ROA4824/ ROB4824	6.000	23,600	287	7.25	4.50	0.75	4.00	1.50	CIH	3.00	2.94	45.0	1306	
RX9506H	–	6.000	23,600	300	7.25	4.50	0.75	4.75	1.50	SIH	3.00	2.94	47.2	1306	
X1311	RO6555 ^⑥	6.500	30,600	412	7.97	5.00	0.88	5.00	1.75	SIH	3.50	3.19	77.9	X1311	
X1307	–	7.000	30,600	385	7.97	5.00	0.88	5.00	1.75	SIH	3.50	3.19	66.0	1307	

① Link-Belt versions no longer available. Unless otherwise noted, Rexnord version is identical to the Link-Belt version. Sections and links may be interchanged.
 ② All bushings are carburized except for RO1315, RO1355, RO1356, ROS1306, & RX95506H, which are thru-hardened.
 ③ All sidebars are thru-hardened except for R506, B578, 1030, 1240.
 ④ All rollers are thru-hardened.
 ⑤ Fabricated steel sprockets are recommended.
 ⑥ Functional equivalent, but not physically identical to, Rexnord equivalent shown.
 ⑦ For track crawler drives with heavy shock loads, select ROS 1306.
 Note: Use pages 87-102 for drive chain selection procedures using selection tables. For alternate selection method using 'rated working load,' see page 106.

Drive Chains

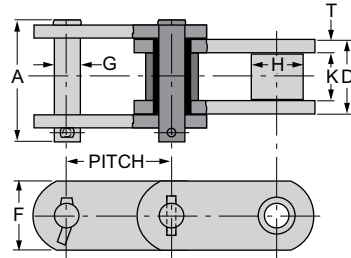

STRAIGHT

Properties

- TH Thru-Hardened
- CARB Carburized
- CIH Circumferentially Induction Hardened
- SIH Selectively Induction Hardened

Dimensions are in inches. Strengths, loads and weights are in pounds.

Rexnord Chain No.	Link-Belt Chain No. ①	Average Pitch	Rated Working Load ^②	Minimum Ultimate Strength, Lbs. x 10 ³	Over-All Width	Bushing Length ^③	Sidebars ^④		Pins		Roller ^⑤ Diameter	Between Sidebars	Average Weight Per Foot	Sprocket Unit No. ⑥
					A	D	Thickness	Height	Diam.	Properties	H	K		
Straight Sidebar Drive Chains														
6425R	—	2.500	6,900	78	3.81	2.27	0.38	2.38	0.88	CIH	1.56	1.48	12.7	645
X345	RS3017 ^⑦	3.000	10,000	124	5.22	3.06	0.56	2.38	0.94	SIH	1.78	1.88	21.8	X345
X1353	—	4.090	16,000	205	5.81	3.50	0.63	3.00 ^⑧	1.31	SIH	2.63	2.18	32.6	X1353
X1365	—	6.000	30,600	407	7.97	5.00	0.88	5.00	1.75	SIH	3.50	3.19	68.0	X1365
A1309	RO7080 ^⑦	7.000	37,150	606	8.00	5.00	0.88	6.00	2.13	TH	4.50	3.13	89.6	A1309
3100 Series Offset Sidebar Chains														
3120CM	ROA3120	1.500	2,100	28	2.28	1.38	0.19	1.81	0.44	TH	0.88	0.97	4.0	ANSI #120
3140CM	ROA3140	1.750	2,500	39	2.50	1.44	0.22	1.63	0.50	TH	1.00	0.97	5.2	ANSI #140
3160CM	ROA3160	2.000	3,450	50	2.91	1.75	0.25	1.88	0.56	TH	1.13	1.19	6.7	ANSI #160
3180	—	2.250	4,800	63	3.31	2.00	0.28	2.13	0.69	CIH	1.41	1.38	9.6	ANSI #180

① Link-Belt versions no longer available. Unless otherwise noted, Rexnord version is identical to the Link-Belt version. Sections and links may be interchanged.

② Use pages 87-102 for drive chain selection procedures using selection tables. For alternate selection method using 'rated working load,' see page 106.

③ All bushings are carburized except for RO1315, RO1355, RO1356, ROS1306, & RX95506H, which are thru-hardened.

④ All sidebars are thru-hardened except for R506, B578, 1030, 1240.

⑤ All rollers are thru-hardened.

⑥ Fabricated steel sprockets are recommended.

⑦ Functional equivalent, but not physically identical to, Rexnord equivalent shown.

⑧ Inner sidebars 3.50.

Welded Steel Chains

Industry's Highest Performance Welded Steel Chains

Rexnord Welded Steel chains are the material handling industry's choice for the most demanding applications. Our customers know that Rexnord chains provide superior strength and durability for extended wear life and trouble free service.

Our years of experience provide unique expertise in material selection, heat treatment and chain design for improved chain strength and long wear life. What this means to you is superior value and greater productivity.

The Rexnord Welded Steel Story

A lot goes into a Rexnord chain that is not visible on the surface. The precision of a diameter or the case depth of an induction hardened part can only be realized after an in-depth analysis. Rexnord regularly tests Rexnord and competitive chains. Not all welded steel chains are created equal. What follows is the story of how we make Rexnord Welded Steel chains to be the best - anywhere in the world.

Maximizing Chain Wear Life Through Superior Heat Treatments

Chain wear life is directly affected by the hardness of the wearing components. Quite simply, the harder the parts, the longer the wear life. Rexnord's heat treatment technology exceeds that of other chain manufacturers.

Computer controlled furnaces, and Rexnord designed induction heat treating equipment, produce chain components with the industry's hardest possible wearing surfaces and yet still provide the necessary toughness to resist shock loads. In addition, unique Rexnord process controls provide chains with consistent wear life. This allows users to predict the wear life of their chains, allowing for chain replacement as part of their preventative maintenance programs. In the end, superior chain eliminates costly and unexpected down time.

All Rexnord Welded Steel chains come standard with "premium" heat treatments. The photo (top right) shows a cross section of a Selectively Induction Hardened (SIH) chain pin. This exclusive Rexnord process involves super hardening only the portion of the chain rivet that wears as the chain articulates over the sprockets. The remainder of the rivet is held at thru-hardening levels



A cross section of a selectively induction hardened WHX pin – the crescent area is super-hardened to dramatically lengthen pin wear life. The balance of the pin material is left in the thru-hardened condition to give the pin excellent toughness.

to assure chain toughness and resistance to breakage. This treatment is standard on WHX Narrow Mill chains. Most manufacturers of welded chain compromise their design, either sacrificing component hardness or resistance to overloads.

Rexnord Wide Mill heat treated chains (WDH) come standard with thru-hardened rivets, sidebars and barrels. Other manufactures short-change wear life by not hardening the barrels – significantly reducing chain wear life.

The table below illustrates the importance of superior heat treatment. By using the table, one can predict the increase in wear life by upgrading the heat treatment. As an example, increasing hardness from 35RC to 60RC could provide up to double the chain life.

Importance of Heat Treatment

Heat Treatment	Not Hardened	Thru-Hardened	Induction Hardened
Hardness RC (typ)	20	35	60
Relative Wear Life*	1	2	4

* Dry operating conditions

Welded Steel Chains

Maximizing Chain Wear Life – (Cont'd.)

The Rexnord story continues with a variety of heat treating options to further extend wear life and increase your plant's productivity. The graphic below represents a chain link with Selectively Induction Hardened (SIH) sidebars. This process can be applied to chain links to greatly improve sliding wear. If you regularly replace chains due to sidebar wear, you should select SIH sidebars. This is a very cost effective way to increase your chain life.

Selectively Induction Hardened Sliding Surfaces

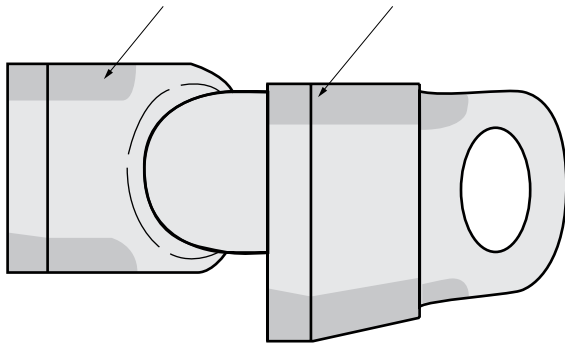

Selectively Induction Hardened sidebars can be ordered to give greater resistance to abrasive sliding wear, thus providing greater sidebar life.

To extend wear life in specially corrosive applications, Rexnord Welded Steel chains can be provided with a variety of plating options or with stainless steel components. Contact Rexnord for application assistance. Let us put 100 years of experience to work for you.

Maximizing Chain Strength

A key factor leading to the durability of Rexnord welded steel chains is superior fatigue strength.

Rexnord Narrow Series Welded Steel chains have tightly controlled, interference fits between the pin and chain sidebar hole. This interference fit creates a beneficial residual stress in the sidebar to greatly increase the fatigue life of the chain. The chains have a "stepped" (3 diameter) pin to ease assembly and protect the integrity of the interference fit.

Competitive chains with poorly controlled interference fits (or with clearance fits) have much lower fatigue strength. Low fatigue strength chains are subject to unexpected chain failures after a chain sees many cycles of loading.

Another key factor in providing maximum chain strength is proper welding, stress relieving, and heat treatment. Improper controls and processes can lead to failures around the weld either from improper weld penetration or by causing high hardness zones that result in brittle failures. Rexnord uses the latest technology in process and quality controls to assure proper weldments.

Rexnord welded links are regularly tested during each manufacturing lot to assure our process is in control, producing high quality welds. The photo below shows a welded steel link that has been destructively tested to assure the strength and penetration of the weld. As demonstrated in the photo, the chain material failed first, not the weld. This demonstrates a high quality weld.

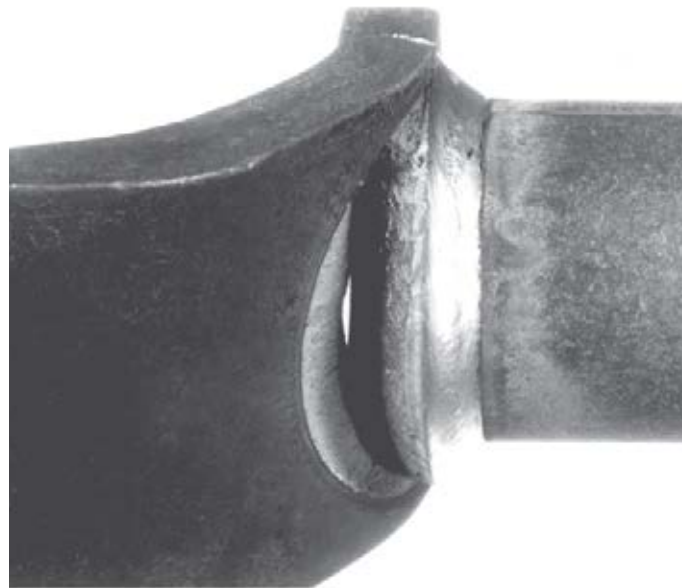

Rexnord's quality assurance program requires welded steel links to be tested for weld strength and penetration.

Maximizing Plant Productivity

Rexnord brings years of application and design experience and an extensive offering of quality chain, bearings and other fine power transmission components. Our sales people and application engineers are eager to work with your organization to maximize the productivity of your plant. Please call us for any assistance we might offer.

Welded Steel Chains

Narrow Series WH, WHX AND WSX

- WH chains have all parts thru-hardened.
- WHX chains have thru-hardened parts and selectively induction hardened rivets as standard.
- WSX chains have all stainless steel construction. Sidebars are 300 series; pins and barrels are precipitation hardened stainless.
- Riveted construction is standard. Pin and cottered construction can be furnished on a made-to-order basis.



Renxord has chosen to offer the higher performance WHX and WSX Series Welded Steel chain instead of the WR Series. This Series is no longer available.

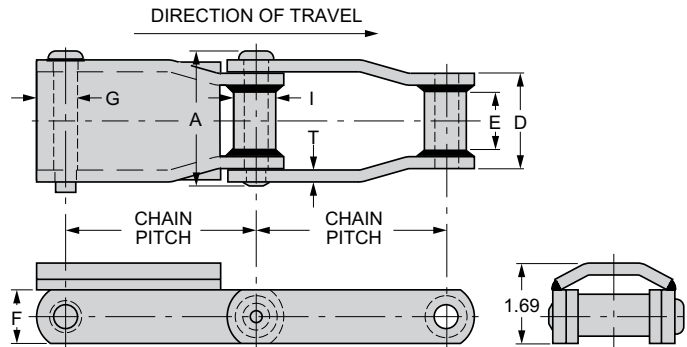
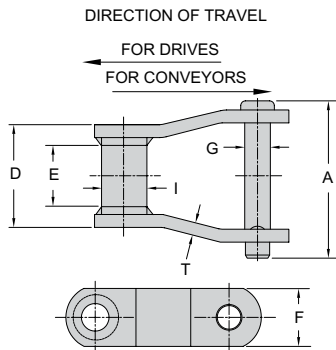

Narrow Series

Dimensions are in inches. Strengths, loads and weights are in pounds.

Renxord Chain No.	Average Pitch	A	E	Sidebars		Pins	Barrel		Minimum Ultimate Strength, Lbs. x 10 ³	Rated Working Load	Average Weight Per Foot	Sprocket Unit No. ①
				Thickness T	Height F		G	D				
WH78	2.609	2.98	1.12	0.25	1.13	0.50	2.00	0.88	24,000	3,500	4	78
WH82	3.075	3.25	1.25	0.25	1.25	0.56	2.25	1.22	29,500	4,400	6	103
WHX124	4.000	4.18	1.63	0.38	1.50	0.75	2.81	1.44	50,500	7,350	9	H124
WHX124HD	4.063	4.82	1.63	0.50	2.00	0.88	3.00	1.63	80,000	9,150	14	H124
WSX124	4.000	4.35	2.01	0.38	1.50	0.75	2.81	1.44	Contact Renxord		14	H124
WHX111	4.760	4.79	2.25	0.38	1.50	0.75	3.38	1.44	50,500	8,850	8	111
WHX106	6.000	4.18	1.63	0.38	1.50	0.75	2.81	1.44	50,500	7,350	7	106
WHX106XHD	6.050	4.87	1.63	0.50	2.00	1.00	3.00	1.75	Contact Renxord		13	106
WH110	6.000	4.57	1.88	0.38	1.50	0.75	3.00	1.25	50,500	7,900	7	110
WHX132	6.050	6.31	3.00	0.50	2.00	1.00	4.38	1.75	85,000	15,000	14	132
WSX132	6.050	6.25	3.00	0.50	2.00	1.00	4.38	1.75	Contact Renxord		14	132
WHX150	6.050	6.31	3.00	0.50	2.50	1.00	4.38	1.75	90,000	15,000	16	132
WHX155	6.050	6.48	2.75	0.56	2.50	1.13	4.38	1.75	102,000	17,500	19	132
WHX157	6.050	6.68	2.75	0.63	2.50	1.13	4.63	1.75	117,000	18,200	20	132
WHX2855	6.050	6.57	2.75	0.63	2.50	1.25	4.63	1.75	140,000	20,250	20	132
WHX3855	6.050	6.57	2.75	0.63	3.00	1.25	4.63	1.75	175,000	20,250	22	132
WHX159	6.125	6.87	2.88	0.63	3.00	1.25	4.63	2.00	204,000	20,250	27	132
WHX4855	12.000	6.57	2.75	0.63	2.50	1.25	4.63	1.75	119,000	20,250	15	4855

① Cast or fabricated sprockets may be used.

Other sizes available upon request. Minimum order quantities may be required on some parts.

Welded Steel Chains

Wide Series – WDH

Rexnord Wide Series chains are furnished standard with all components heat-treated (WDH Series). WDH Series chains are intended for use in applications where joint wear, barrel OD wear, and sidebar wear are a problem.

- WDH Series have all parts thru-hardened.
- Riveted construction is standard. Pin and cottered construction can be furnished on a made-to-order (MTO) basis.
- Lube holes drilled into barrels is an MTO option.
- Induction hardened pins are an MTO option.
- Galvanized pins are an MTO option.

➔ Rexnord has found that some competitive wide mill drag chains use a low carbon steel for their barrels. A low carbon steel will not respond to heat treatment even though it may be put in a furnace and attempted to be heat treated. Rexnord Welded Steel chains use medium carbon steel barrels that respond very well to heat treatment and provide twice the wear resistance of these low carbon barrels. Harder components, longer life.

Rexnord has chosen to offer the higher performance WDH Series Welded Steel chain instead of the WD Series. This Series is no longer available.

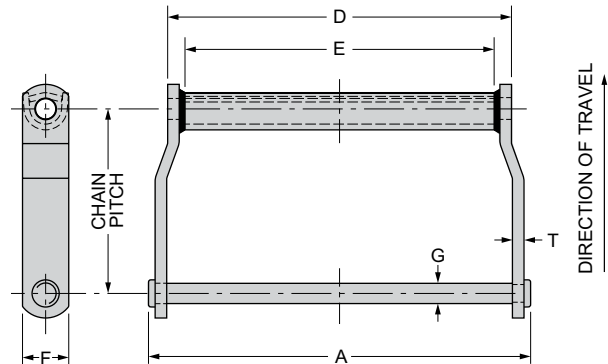

Rexnord Wide Series chains are specially designed for loads and operating conditions imposed by drag conveyor service. As with our Narrow Series, many material and configuration options are available.

Dimensions are in inches. Strengths, loads and weights are in pounds.

Rexnord Chain No.	Average Pitch	A	E	Sidebars		Pins	Barrel Length	Minimum Ultimate Strength, Lbs. x 10 ³	Rated Working Load	Average Weight Per Foot	Sprocket Unit No. ^①
				Thickness	Height						
WDH Series				T	F	G	D	WDH Series	WDH Series		
WDH104	6.000	6.75	4.13	0.38	1.50	0.75	5.38	55,000	10,000	9	H104
WDH110	6.000	11.8	9.00	0.38	1.50	0.75	10.38	55,000	10,000	12	H110
WDH113	6.000	12.5	9.00	0.50	1.50	0.88	10.63	57,000	11,700	18	H110
WDH120	6.000	12.1	8.75	0.50	2.00	0.88	10.25	79,000	15,000	20	H120
WDH112	8.000	11.8	9.00	0.38	1.50	0.75	10.38	55,000	10,000	10	H112
WDH116	8.000	15.5	13.0	0.38	1.75	0.75	14.13	59,000	11,500	13	H116
WDH118	8.000	16.8	13.3	0.50	2.00	0.88	14.88	79,000	15,000	21	WD118 ^②
WDH480	8.000	14.6	11.2	0.50	2.00	0.88	12.75	79,000	15,000	18	H480
WDH580	8.000	14.6	11.2	0.50	2.00	1.00	12.75	108,000	20,500	18	H480
WDH680	8.000	15.33	11.2	0.63	2.00	1.00	13.00	108,000	20,500	21	H480

^① Cast or fabricated steel sprockets may be used except as noted.

^② Available as a fabricated steel sprocket only.

Other sizes available upon request. Minimum order quantities may be required on some parts.

Welded Steel Chains

Reverse Barrel Wide Mill Drag Chains

A simple and effective solution for an old problem.

The Problem: Since their introduction, wide mill welded steel chains were designed to run “narrow” or “closed end” forward. This is the direction of travel that the chains on the preceding page run. Running in this direction, an offset sidebar chain will experience scrubbing between the outside of the chain’s barrel and the drive sprocket’s tooth (Figure 1). On shorter conveyors, where the chain frequently contacts the sprocket, this scrubbing can cause rapid wear of both the chain and sprocket. This scrubbing may not cause as much chain wear on longer conveyors but it will still cause sprocket wear.

The Solution: Rexnord engineers realized that if they reversed the barrel of the chain so it could run in the opposite direction, “wide” or “open end” forward, the scrubbing action could be eliminated. Instead of the articulation occurring between the outside of the chain barrel and the sprocket tooth it occurs inside the chain joint between the pin and the barrel (Figure 2). This arrangement is preferable since both the pin and the barrel of the wide mill chains are heat treated to withstand this type of wear.

How do I Know if I Need Reverse Barrel Chain?

Note the difference in position of the pin within the barrel in Figures 1 and 2. When running narrow end forward and the engaged pin is being pulled forward at the time of engagement and the pin of the previous link is being pulled against the front of the barrel.

When reverse barrel chain is run wide end forward (Figure 2), the sprocket is pushing against the force applied. This may extend the useful life of chains used in long and/or heavy loaded applications where the typical mode of chain failure is breaking at the barrel welds.

Articulation is Between Chain Barrel and Sprocket Tooth

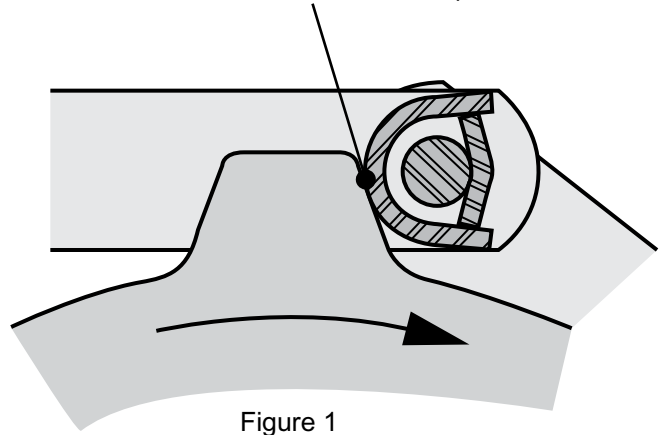

Figure 1

Articulation is Between Pin and Barrel

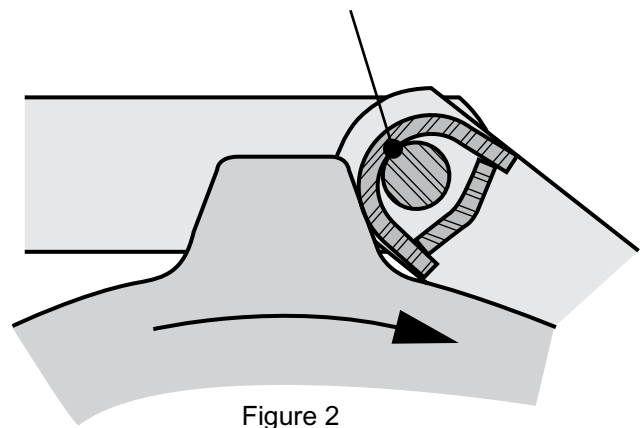
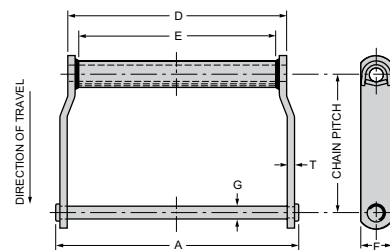

Figure 2



Dimensions are in inches. Strengths, loads and weights are in pounds.

Rexnord Chain No.	Average Pitch	A	E	Sidebars		Pins G	Barrel Length D	Minimum Ultimate Strength, Lbs. x 10 ³	Rated Working Load	Average Weight Per Foot	Sprocket Unit No.
				Thickness T	Height F						
				WDH2210	6.136						
WDH2316	8.126	15.8	13.00	0.38	1.75	0.75	14.13	55,000	11,500	13	H116
WDH2380	8.161	14.6	11.25	0.50	2.00	0.88	12.75	79,000	15,000	18	H480

Other sizes available upon request. Minimum order quantities may be required on some parts.

Welded Steel Chains

Heavy Duty Welded Steel Drag Chains

Rexnord Heavy Duty drag chains are ideal for conditions where severe abrasion and heat exist. They offer these important features and benefits:

- **Hardface welding** on both of the chain's sliding surfaces is standard. A typical weld hardness of 60 RC and a heavy weld bead give this chain excellent sliding wear resistance in cold and hot clinker applications.
- **Interference fits** between the pin and chain sidebar dramatically improves chain strength and joint wear life over that of a cast drag chain. In addition, this eliminates loose pin movement in the chain joint.

- **An induction hardened pin** affords the best of two worlds – a 60 RC typical hardened case and impact resistant material in the core of the pin. The result is longer service life and superior resistance to shock loads.
- **Square edges on the wing and sidebar** of welded drag chain convey more efficiently than rounded cast chain edges. They also move a deeper bed of material with each revolution of the chain.
- **Heat treated and fabricated steel components** eliminate the failures that cast chains experience from casting porosity and inclusions.

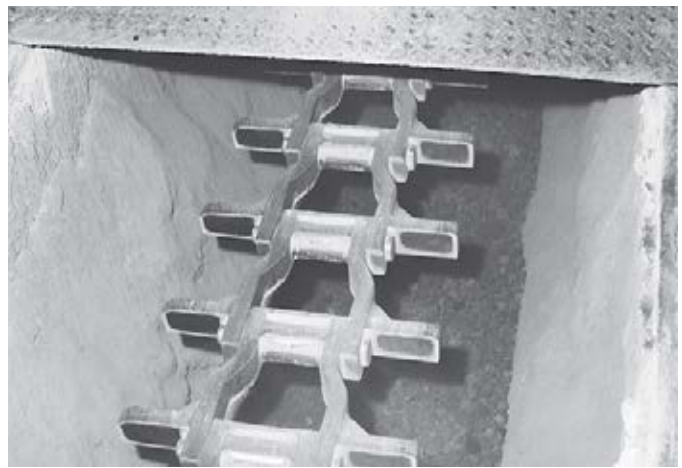
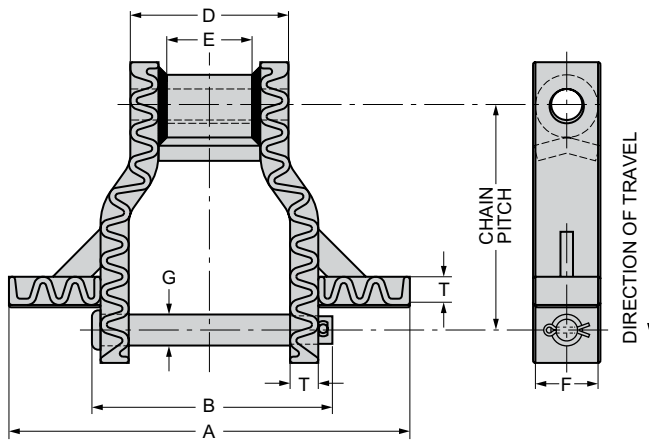

WHX Drag chains offer solutions to wear and breakage problems common with cast chains. Fabricated steel construction with heat treated pins, barrels, face plates, wings, and sidebars provide added protection not found in cast chain designs.

Properties

- TH Thru-Hardened
- CIH Circumferentially Induction Hardened
- SIH Selectively Induction Hardened

Dimensions are in inches. Strengths, loads and weights are in pounds.

Rexnord Chain No.	Average Pitch	A	Sidebars			Pins			Barrel Length		Minimum Ultimate Strength, Lbs. x 10 ³	Rated Working Load	Sprocket Unit No.
			Thickness	Height	Heat Treat	B	G	Heat Treat	D	E			
			T	F									
WHX5157	6.050	8 to 14 inches 2 inch increments	0.63	2.5	TH	6.94	1.13	SIH	4.63	2.75	117,000	18,200	5157 ②
WHX6067	9.000	10 to 26 inches 2 inch increments	0.75	2.5	TH	8.19	1.25	CIH	5.5	3.63	195,000	24,300	6121 ②
WHX5121 ①	9.000	10 to 30 inches 2 inch increments	1.13	2.5	TH	9.75	1.25	CIH	6.31	3.63	205,000	27,600	6121 ②
WHX6121	9.000	10 to 30 inches 2 inch increments	1.13	2.5	TH	9.75	1.25	CIH	6.31	3.63	205,000	27,600	6121 ②

① WHX5121 is dimensionally the same as WHX6121 except it runs closed end forward.

② Octagonal tail wheels are available. The octagonal design reduces the scrubbing which reduces traditional tail sprocket life. See page 71.

Other sizes available upon request. Minimum order quantities may be required on some parts.

Welded Steel Chains

Attachment Welding Instruction

1. Surfaces to be welded should be clean and free of foreign material. It is not necessary to remove the pre-lubricant before welding, however, proper ventilation is mandatory.
2. Weld strength should be sufficiently high to cause failure of the parent metal and not of the weld itself.
3. Welds should be free of cracks, undercutting, slag, inclusions, and excessive porosity. Craters due to stop welding should be located away from corners and edges; most craters contain slight cracks which can initiate failures at high stress areas.
4. Weld beads should be free of pinholes, have uniformly fine surface ripples, and have little or no indication of where a new piece of filler metal was started.
5. Weld edges should indicate complete fusion without overlap or undercut.
6. Welds should be clean, free of spatter, slag, excessive oxides and arc scars.
7. Arcs should be struck on attachments, not on the sidebars. Arc scars on sidebars can produce early chain failure.
8. Convex shaped weld beads are preferred. Convex fillet welds are strong and less subject to cracking than concave forms.
9. Electrode selection is very important. An electrode that has been successfully used is E7018 (70,000 psi tensile strength, low hydrogen). This rod is for all position use, AC or DC. Good welding practice dictates that electrodes be stored in a dry atmosphere or baked prior to use. Specific electrode manufacturer recommendations should be closely followed.
10. Preheating and Postheating – Heat applied to the weld heat affected zone is always beneficial. These processes, while not generally required for small attachments, are recommended for large or heavily loaded attachments such as Styles “A” & “C” log cradles. No welding should be performed on parts below 70°F.

Heating is usually done by use of a neutral flame to heat the parts prior to or after welding.

Preheat: Performed to reduce possibility of weld cracking both surface and subsurface. Parts to be welded – link and attachment – should be heated uniformly to 300°F.

Postheat: Performed to relieve internal stresses and to reduce weld zone hardness. Heat affected zone of weld heated to 700°F.

11. Tack welds should never be used in areas that will not be welded in the finished product.

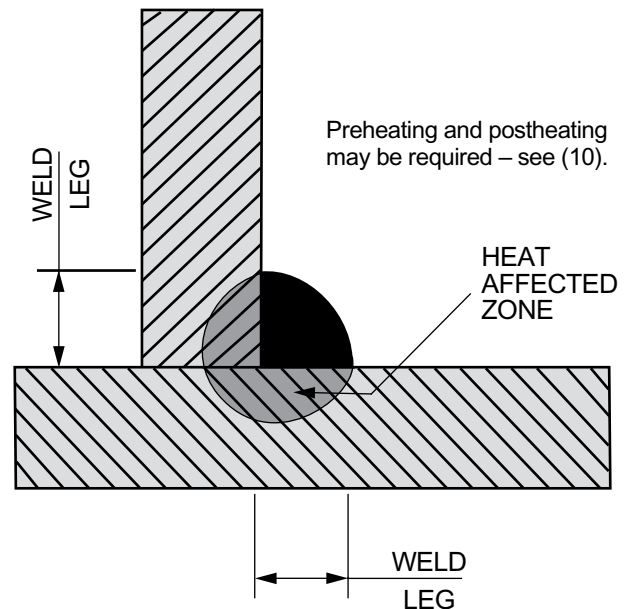

CAUTION

No welding should be performed on or immediately adjacent to an induction hardened or carburized part. Welding to an induction hardened part can produce tempering and softening of this hard surface. Welding attachments to the carbon rich surface of a carburized part will result in brittle welds and possible cracking.

Welded Steel Chains - Attachments

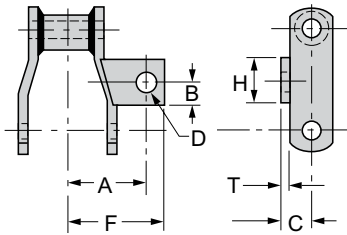

A1

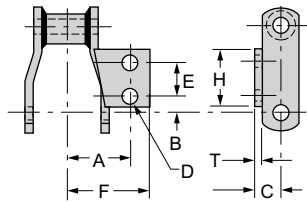

A2, A25

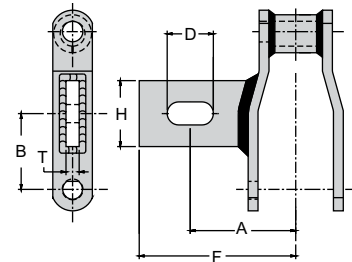

A12, A22, A24

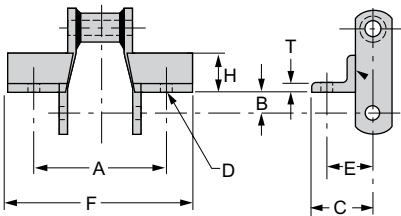

F2

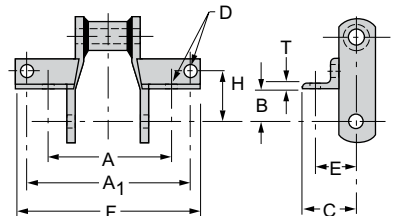

F4

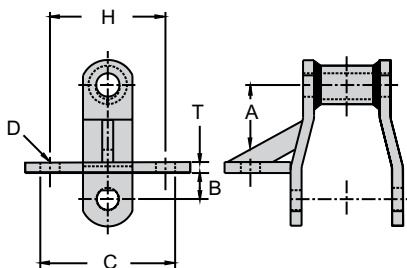

G19

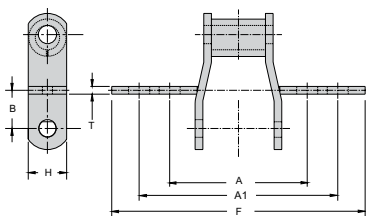

G22

Dimensions are in inches. Weights are in pounds.

Chain Number	A	B	C	D		E	F	H	T	Average Weight per Ft.
				Bolt Dia.	Bolt Hole					
A1										
WH78	2.00	1.25	0.81	$\frac{3}{8}$.41	—	2.50	1.25	0.25	5
WH82	2.09	1.50	0.88	$\frac{3}{8}$.41	—	2.75	1.75	0.25	6
A2 & A25 ③										
WH78	2.00	0.41	0.81	$\frac{3}{8}$.41	1.13	2.50	2.00	0.25	5
WH82	2.13	0.75	0.88	$\frac{3}{8}$.41	1.31	2.69	2.25	0.25	7
WHX124	2.63	0.88	1.13	$\frac{3}{8}$.41	1.94	3.19	3.00	0.38	10
WHX124HD	2.63	0.94	1.50	$\frac{1}{2}$.56	1.94	3.19	3.06	0.50	16
WHX111	3.13	1.22	1.13	$\frac{1}{2}$.56	2.31	3.75	3.50	0.38	10
WHX132 ④	3.75	1.63	1.50	$\frac{1}{2}$.56	2.75	4.59	4.25	0.50	16
WHX150	3.75	1.63	1.75	$\frac{1}{2}$.56	2.75	4.59	4.19	0.50	19
WHX155	3.75	1.63	1.81	$\frac{1}{2}$.56	2.75	4.59	4.19	0.56	22
WHX157	4.00	1.75	1.88	$\frac{1}{2}$.56	2.50	4.78	4.00	0.63	22
WHX159	4.00	1.69	2.13	$\frac{1}{2}$.56	2.75	4.78	4.25	0.63	30
A12 ①, A22, A24 ②										
WH78 ①	1.88	1.31	—	$\frac{3}{8}$.41	—	2.50	1.00	0.38	5
WHX106	3.75	2.88	—	$\frac{5}{8}$.69	—	5.25	2.50	0.50	7
WHX106 ②	4.00	2.88	—	$\frac{13}{16}$	1.75	—	5.94	2.50	0.50	10
F2										
WH78	3.75	0.56	2.31	$\frac{3}{8}$.41	1.44	4.69	1.25	0.25	6
F4										
WH78	3.75 ④	0.69	2.31	$\frac{3}{8}$.41	1.75	5.50	1.94	0.25	8
WH82	4.13 ④	0.81	2.38	$\frac{3}{8}$.41	1.81	5.94	1.94	0.25	9
WHX124	4.38 ④	0.88	3.06	$\frac{3}{8}$.41	2.06	6.19	2.30	0.38	12
G19										
WH78	2.187	0.59	3.75	0.38	—	—	2.78	2.63	0.25	—

- ① A12 attachment is for WH78.
- ② A22 & A24 attachments are for WHX106.
- ③ A25 attachment is for WHX132.
- ④ A1 is 4.50 for WH78, 5.00 for WH82 and 5.25 for WHX124.

Chain Number	A	A1	B	C	D ①		F	H	T	Average Weight per Ft.
					Bolt Dia.	Bolt Hole				
G22										
WH82	4.50	6.50	1.25	—	0.31	—	8.30	1.25	0.25	—

① All holes round and straight.

Other sizes and attachments available upon request. Minimum order quantities may be required on some parts.

Welded Steel Chains - Attachments

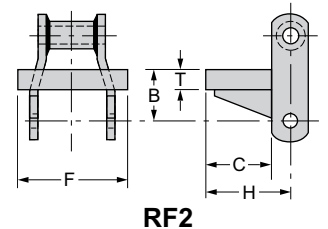
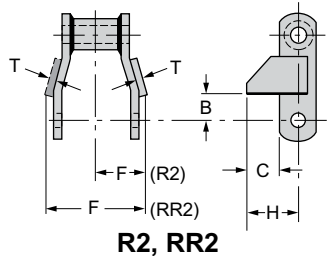
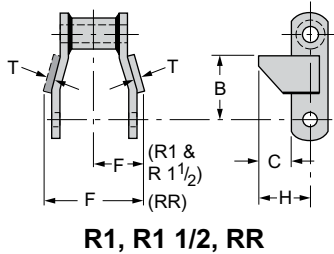
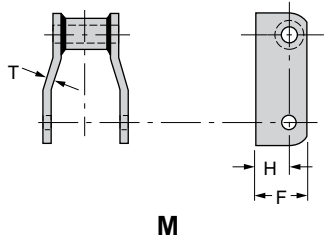
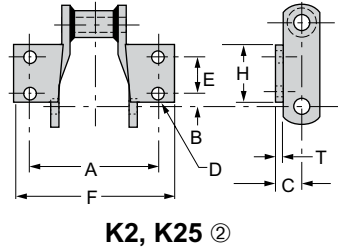
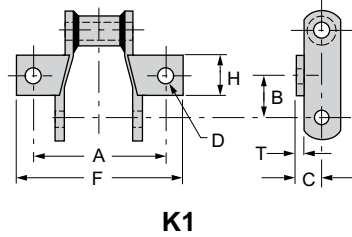
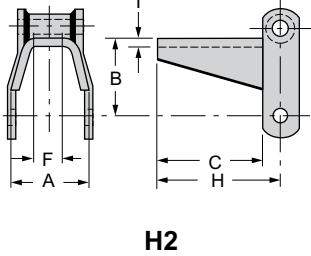
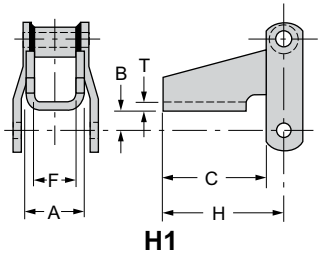

Dimensions are in inches. Weights are in pounds.

Chain Number	A	B	C	D ①		E	F	H	T	Average Weight per Ft.
				Bolt Dia.	Bolt Hole					
H1										
WH78	1.75	0.50	3.06	—	—	—	0.88	3.63	0.25	8
WH82	2.00	0.63	3.00	—	—	—	1.13	3.63	0.25	10
H2										
WH78	2.94	2.38	3.00	—	—	—	1.00	3.56	0.25	8
WH82	2.56	2.69	3.00	—	—	—	1.00	3.63	0.25	9
K1										
WH78	4.00	1.25	0.81	3/8	.41	—	5.00	1.25	0.25	6
WH82	4.19	1.50	0.88	3/8	.41	—	5.50	1.75	0.25	7
K2 & K25 ②										
WH78	4.00	0.41	0.81	3/8	.41	1.13	5.00	2.00	0.25	6
WH82	4.25	0.75	0.88	3/8	.41	1.31	5.38	2.25	0.25	8
WH110	5.31	2.13	1.13	3/8	.41	1.75	6.50	3.00	0.38	8
WHX111	6.25	1.22	1.13	1/2	.56	2.31	7.50	3.50	0.38	12
WHX124	5.25	0.88	1.13	3/8	.41	1.94	6.38	3.00	0.38	12
WHX124HD	5.25	0.94	1.50	1/2	.56	1.94	6.38	3.06	0.50	18
WHX132 ②	7.50	1.63	1.50	1/2	.56	2.75	9.19	4.25	0.50	19
WHX150	7.50	1.63	1.75	1/2	.56	2.75	9.19	4.19	0.50	22
WHX155	7.50	1.63	1.81	1/2	.56	2.75	9.19	4.19	0.56	25
WHX157	8.00	1.75	1.88	1/2	.56	2.50	9.56	4.00	0.63	26
WHX159	8.00	1.69	2.13	1/2	.56	2.75	9.56	4.25	0.63	35

① All holes round and straight.
② K25 attachment is for WHX132

Dimensions are in inches. Weights are in pounds.

Chain Number	A	B	C	Bolt Diameter Required		E	F	H	T	Average Weight per Ft.
				D	D					
M										
WHX132	—	—	—	—	—	—	3.00	2.00	0.50	18
WHX157	—	—	—	—	—	—	3.50	2.25	0.63	26
WHX159	—	—	—	—	—	—	4.00	2.50	0.63	35
R1										
WH78	—	1.88	1.00	—	—	—	1.50	1.56	0.25	5
WH82	—	2.18	1.25	—	—	—	1.63	1.88	0.25	6
WHX124	—	2.72	1.13	—	—	—	2.16	1.88	0.38	9
R1 1/2										
WH78	—	1.88	1.50	—	—	—	1.50	2.06	0.25	5
RR										
WH78	—	1.88	1.00	—	—	—	3.00	1.56	0.25	5
WH82	—	2.19	1.25	—	—	—	3.25	1.88	0.25	7
WHX124	—	2.72	1.13	—	—	—	4.34	1.88	0.38	10
WHX124HD	—	2.72	1.13	—	—	—	5.13	2.13	0.50	18
R2										
WH78	—	0.69	1.00	—	—	—	1.50	1.56	0.25	5
WH82	—	0.88	1.25	—	—	—	1.63	1.88	0.25	6
WHX124	—	1.25	1.13	—	—	—	2.16	1.88	0.38	9
RR2										
WH78	—	0.69	1.00	—	—	—	3.00	1.56	0.25	5
WH82	—	0.88	1.25	—	—	—	3.25	1.88	0.25	7
WHX124	—	1.25	1.13	—	—	—	4.31	1.88	0.38	10
RF2										
WH78	—	1.50	2.13	—	—	—	3.00	2.69	0.63	10
WHX124	—	2.50	2.50	—	—	—	4.25	3.25	1.00	19
WHX124HD	—	2.50	2.50	—	—	—	4.75	3.50	1.00	25

Other sizes and attachments available upon request.
Minimum order quantities may be required on some parts.

Welded Steel Chains - Attachments

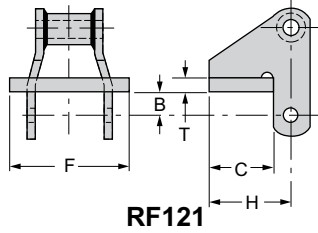

RF121

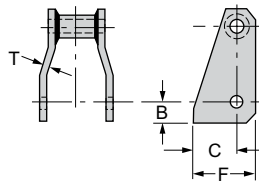

S1, S3

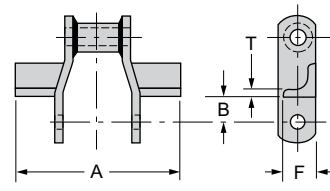

Wing

Dimensions are in inches. Weights are in pounds.

Chain Number	A	B	C	Bolt Diameter Required D	E	F	H	T	Average Weight per Ft.
RF121									
WHX132	-	1.56	4.00	-	-	12.0	5.00	1.50	55
WHX150	-	1.56	4.00	-	-	12.0	5.25	1.50	57
WHX155	-	1.56	4.00	-	-	12.0	5.25	1.50	61
WHX157	-	1.50	4.00	-	-	12.0	5.25	1.50	63
WHX159	-	1.56	4.00	-	-	12.0	5.50	1.50	83
S1 & S3 ①									
WHX132	-	1.16	5.00	-	-	6.00	-	0.50	25
WHX150	-	1.16	5.25	-	-	6.50	-	0.50	27
WHX157	-	1.50	5.25	-	-	6.50	-	0.63	34
WHX157 ①	-	1.75	3.50	-	-	4.75	-	0.63	34
Wing									
WH78	6.00	0.75	-	-	-	1.00	-	0.25	7
WH82	6.50	0.94	-	-	-	1.25	-	0.25	9
WHX124	8.50	1.19	-	-	-	1.50	-	0.25	14
WHX124HD	8.50	1.38	-	-	-	2.00	-	0.38	19
WHX132	12.0	1.50	-	-	-	2.00	-	0.38	24
WH260	7.00	0.53	-	-	-	1.75	-	-	4
"A" Style Cradle									
WHX132	-	-	3.00	-	-	11.0	3.00	-	22
WHX150	-	-	3.50	-	-	11.0	3.00	-	25
WHX155	-	-	3.50	-	-	11.0	3.00	-	28
WHX157	-	-	3.50	-	-	11.0	3.00	-	29
WHX159	-	-	4.00	-	-	11.0	3.00	-	39
"C" Style Cradle									
WHX132	-	-	3.00	-	-	11.0	3.00	-	29
WHX150	-	-	3.00	-	-	11.0	3.00	-	31
WHX155	-	-	3.00	-	-	11.0	3.00	-	34
WHX157	-	-	3.00	-	-	11.0	3.00	-	35
WHX159	-	-	4.00	-	-	11.0	3.00	-	47

① S3 attachment is for WHX157.

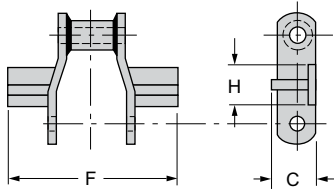

"A" Style

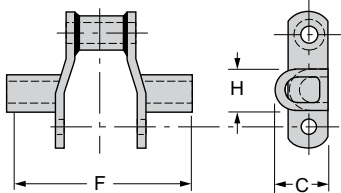

"C" Style

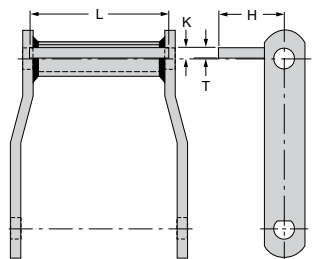

C1, C3, C4

Dimensions are in inches. Weights are in pounds.

Chain Number	H	K	L	T	Average Weight per Ft.
C1 - Wide Series					
WDH102	1.50	0.38	6.38	0.38	15
WDH104	2.38	0.38	4.13	0.38	11
WDH110	2.38	0.38	9.13	0.38	17
WDH112	2.38	0.38	9.13	0.38	14
WDH116	2.63	0.38	12.75	0.38	20
C3 - Wide Series					
WDH113	2.25	0.50	9.13	0.50	19
WDH118	3.00	0.50	13.00	0.50	25
WDH120	3.00	0.50	8.63	0.50	26
WDH122	3.00	0.50	8.63	0.50	21
WDH480	3.00	0.50	11.13	0.50	26
WDH580	3.00	0.50	11.13	0.50	26
C4 - Wide Series					
WDH104	3.75	0.38	4.13	0.38	12
WDH110	3.75	0.38	9.13	0.38	21
WDH112	3.75	0.38	9.13	0.38	17
WDH113	4.75	0.50	9.13	0.50	28
WDH116	4.88	0.38	12.75	0.38	25
WDH480	5.00	0.50	11.13	0.50	33
WDH580	5.00	0.50	11.13	0.50	33

Other sizes and attachments available upon request.
Minimum order quantities may be required on some parts.

Welded Steel Chains - Attachments

Dimensions are in inches. Weights are in pounds.

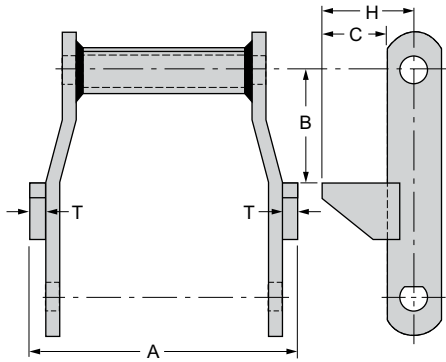

RR

Chain Number	A	B	C	H	T	Average Weight per Ft.
RR – Wide Series						
WDH104	6.94	3.00	1.75	2.50	0.38	9
WDH110	11.94	3.00	1.75	2.50	0.38	14
WDH112	11.94	3.00	1.75	2.50	0.38	12
WDH113	12.69	3.00	1.75	2.50	0.50	16
WDH116	15.69	3.00	2.25	3.13	0.38	17
WDH118	16.94	3.00	2.25	3.25	0.50	22
WDH120	12.34	3.00	2.25	3.25	0.50	23
WDH122	12.34	3.00	2.25	3.25	0.50	19
WDH480	14.88	3.00	2.25	3.25	0.50	21
WDH580	14.88	3.00	2.25	3.25	0.50	21
WDH2210	12.09	3.00	–	2.50	0.38	13
WDH2316	15.91	3.00	–	3.00	0.38	16
WDH2380	14.78	3.00	–	3.25	0.50	21

Dimensions are in inches. Weights are in pounds.

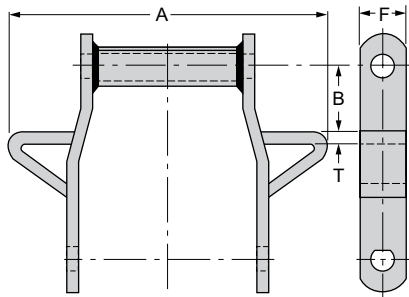

Wing (Wide)

Chain Number	A	B	F	T	Average Weight per Ft.
Wing – Wide Series					
WDH104	11.50	2.75	1.50	0.38	11
WDH110	17.00	2.63	1.50	0.38	16
WDH112	17.00	3.25	1.50	0.38	13
WDH113	17.00	2.50	1.50	0.50	17
WDH116	22.00	3.25	1.75	0.38	18
WDH120	17.00	3.25	2.00	0.50	28
WDH122	17.00	3.25	2.00	0.50	24
WDH480	22.00	3.25	2.00	0.38	25
WDH580	22.00	3.25	2.00	0.50	25
WDH680	14.34	–	2.00	–	–
WDH2210	17.00	2.25	1.50	0.38	16
WDH2316	22.00	3.25	1.75	0.38	18
WDH2380	22.00	3.25	2.00	0.50	26

Other sizes and attachments available upon request.
Minimum order quantities may be required on some parts.

Cast Chains

Engineered Steel and Welded Steel chains are recommended for most applications. Engineered Steel construction is strongly recommended for bucket elevator applications.

Cast chains (pages 47-50) may be slightly better suited to applications involving severely corrosive atmospheres or where chain temperatures reach above 500°F. Contact Rexnord for recommendations relating to the specific application.

Cast Combination chains (pages 51-52) may provide superior service where heavy downward loading and sliding across an extremely gritty or abrasive surface has resulted in a chain wear problem. Where, in addition, problems have been encountered with chain breakage due to heavy impact loading.



All Cast and Cast Combination chains are 100% inspected and proof tested to ensure that no poorly molded links leave the factory.

Mill – Narrow Series

Narrow Series Mill chains are used primarily for drag conveyor service in the forest products industry, but are also used in many other applications where a sliding chain is required. The closed joint construction permits operation in a moderately dusty or abrasive atmosphere.

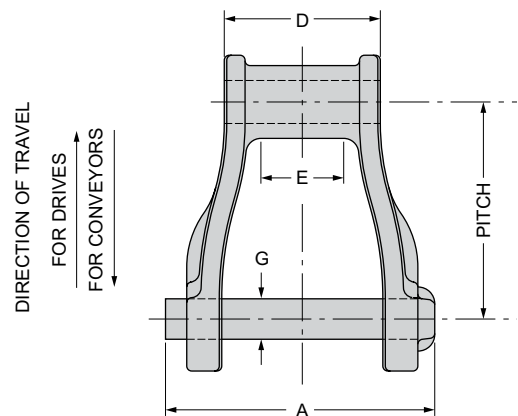

Dimensions are in inches. Strengths, loads and weights are in pounds.

Chain No.	Average Pitch	A	D	E	Sidebars		Barrel Diameter	Rated Working Load	Average Weight Per Foot	Recommended Max. RPM for 12T Sprocket	Sprocket Unit No. ①
					F	G	H				
H74	2.609	3.06	1.63	0.94	1.00	0.38	0.88	1,850	3.0	115	78
H78	2.609	3.50	1.88	0.94	1.13	0.50	0.94	2,850	4.2	115	78
H82	3.075	4.06	2.19	1.25	1.25	0.56	1.22	3,700	5.5	90	103
H124	4.000	4.75	2.81	1.88	1.50	0.75	1.38	5,000	8.8	75	H124

① Cast or fabricated sprockets may be used. See pages 53-55 for attachment listings.

Cast Chains

Pintle

Pintle chains are ideal for oven and furnace conveying operations. They are also suitable for a variety of low speed drive applications. The closed pin joint construction permits operation in a moderately dusty or abrasive atmosphere.

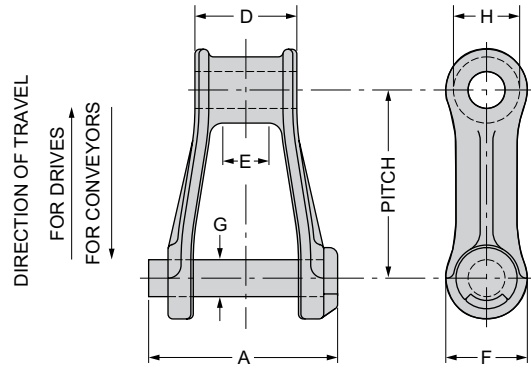

Furnished pin and cotter as standard.

Rexnord Pintle Chains – 400/900 Series and 700 Series

Dimensions are in inches. Strengths, loads and weights are in pounds.

Chain No.	Average Pitch	A	D	E	Sidebars	Pins	Barrel Diameter	Rated Working Load	Average Weight Per Foot	Recommended Max. RPM for 12T Sprocket	Sprocket Unit No. ①
					F	G	H				
945	1.630	2.06	1.06	0.69	0.75	.31	0.63	830	1.5	230	45
955	1.630	2.25	1.13	0.69	0.84	.38	0.63	1,060	1.9	230	45
977	2.308	2.50	1.25	0.69	1.00	.44	0.81	1,650	2.0	135	67
988	2.609	3.00	1.63	0.88	0.94	.44	0.88	2,150	2.9	115	78
C9103	3.075	3.69	1.88	1.13	1.50	.75	1.25	4,250	5.7	90	103
C720	6.000	3.63	1.88	1.00	1.50	.69	1.38	3,220	4.2	35	720S
720S	6.000	3.94	1.88	1.44	1.56	.75	1.44	4,250	5.1	35	720S
A730	6.000	3.94	2.00	1.13	1.75	.75	1.50	4,500	6.0	35	A730
CS720S	6.000	3.94	1.88	1.13	1.56	.75	1.44	4,250	5.4	35	CS720S
CS730	6.000	3.94	2.00	1.13	1.75	.75	1.50	4,500	6.4	35	CS730
SCA9103	3.075	3.69	1.88	1.13	1.50	.75	1.25	4,250	5.7	90	103

① Cast or fabricated sprockets may be used.

Cast Chains

900 Series Pintle Chains

900 Pintle chains, often called intermediate carrier chains, are widely used in the sugar industry. Multiple strands, fitted with overlapping, beaded slats, form a continuous apron conveyor for intermediate carrier service.

The renewable bushings provide a hard, durable pin-bearing surface and permit high working loads.

Links have outboard driving lugs for operation on double sprockets. This method of engagement prevents the jamming of cane in the link pockets.

All links have generous sliding surfaces to resist wear. Wear shoes at the open end of the link support the chain and lessen the weight on the pin, thereby reducing joint wear. Heavy cross-sections, formed by the wear shoes and reinforcing ribs, strengthen the links. Slots cast in the lugs protect the pin ends and prevent pin rotation.

Links are available in cast material and stainless steel. Pins and bushings are available in case-hardened steel or stainless steel.

Chains with cast links and stainless steel pins and bushings are normally recommended. For greater corrosion resistance all stainless steel chains are preferred.

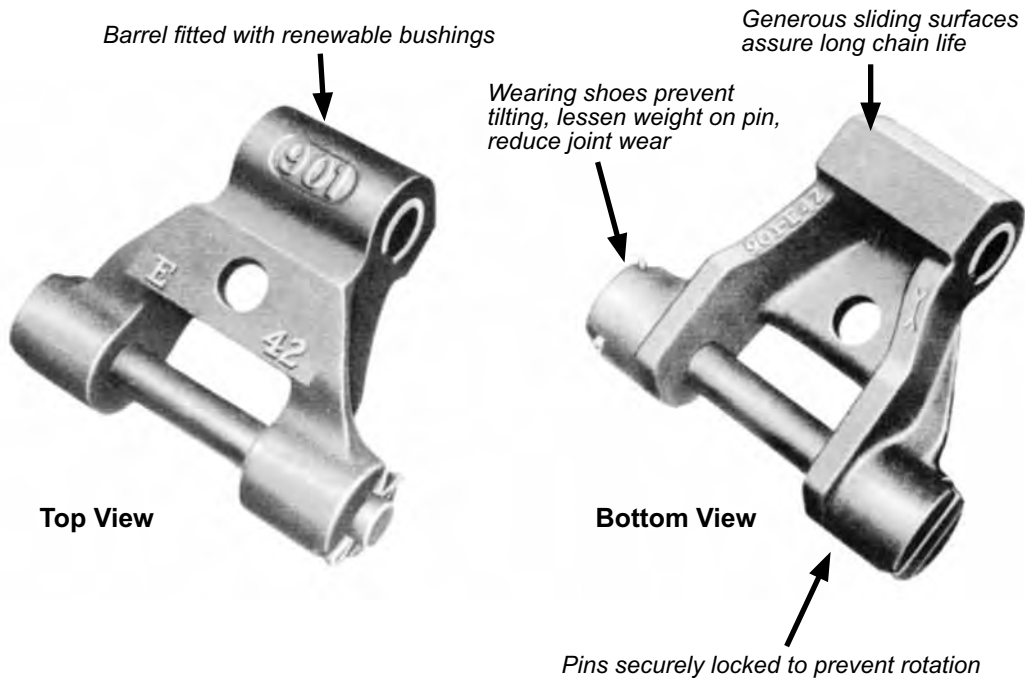

Link-Belt 900 Series Pintle Chains

Dimensions are in inches. Strengths, loads and weights are in pounds.

Link-Belt Chain No.	Average Pitch	Rated Working Load	Average Weight	Sprocket Unit No.	Attachments Available
901	3.149	4,150	12.2	901	E42, E43
902	2.970	4,150	12.5	902	E42, E43
907	3.170	4,150	12.1	907	E51

Cast Chains

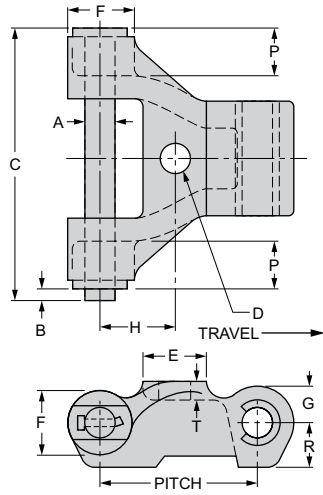

E42, E51

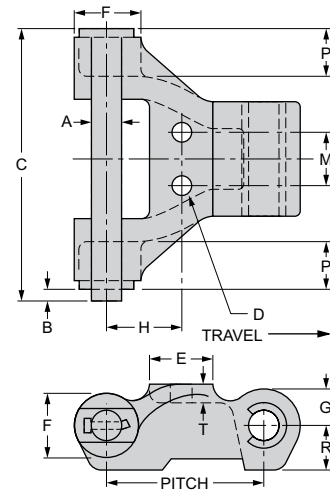

E43

Dimensions are in inches. Weights are in pounds.

Chain No.	A	B	C	D	E	F	G	H	M	P	R	T	Weight
E42 ①													
901	.625	.19	5.50	.66	1.25	1.34	.78	1.58	—	1.13	.94	.36	12.2
902	.625	.19	5.50	.66	1.25	1.34	.88	1.48	—	1.13	.94	.36	12.5
E43													
902	.625	.19	5.50	.41	1.25	1.34	.88	1.38	1.09	1.13	.94	.36	12.5

① Slats may be assembled with laps leading or trailing.

Cast Chains

Combination

Combination chains are used extensively for conveyor applications. Because the chain joints are well protected and have generous pin bearing surfaces, they are widely used for handling stone, gravel and similar materials. They are also used for drag conveyor applications because the large link surfaces provide long wear life.

Link-Belt Standard Series Cast Combination Chains

Dimensions are in inches. Strengths, loads and weights are in pounds.

Link-Belt Chain No.	Average Pitch	A	D	E	T	Sidebars	Pins	Barrel Diameter	Rated Working Load	Average Weight Per Foot	Recommended Max. RPM for 12T Sprocket	Sprocket Unit No. ①
						F	G	H				
C55	1.630	2.06	1.20	0.60	0.19	0.75	0.38	0.63	1,100	2.0	230	55
C77	2.308	2.19	1.25	0.50	0.19	0.88	0.44	0.72	1,400	2.2	135	67
C188	2.609	2.69	1.56	0.74	0.25	1.13	0.50	0.88	2,400	3.6	115	78
C131	3.075	3.47	2.03	1.09	0.38	1.50	0.63	1.22	3,800	6.5	90	103
C102B	4.000	4.31	2.88	1.63	0.38	1.50	0.63	0.97	5,000	6.7	60	102B
C102½	4.040	4.59	2.97	1.92	0.38	1.75	0.75	1.38	6,700	9.2	60	102½
C111	4.760	4.72	3.38	2.12	0.38	1.75	0.75	1.44	7,500	9.6	45	111
C133	6.000	3.88	2.25	1.25	0.38	2.00	0.88	1.75	5,000	8.8	35	133
C110	6.000	4.31	2.88	1.76	0.38	1.50	0.63	1.25	5,000	6.0	35	110
C132	6.050	6.27	4.38	2.62	0.50	2.00	1.00	1.72	10,500	14.0	30	132

① Cast or fabricated sprockets may be used. See pages 70-71 for attachment listings.

Available in riveted or cottered construction. Cottered construction shown. Cottered construction furnished unless otherwise specified.

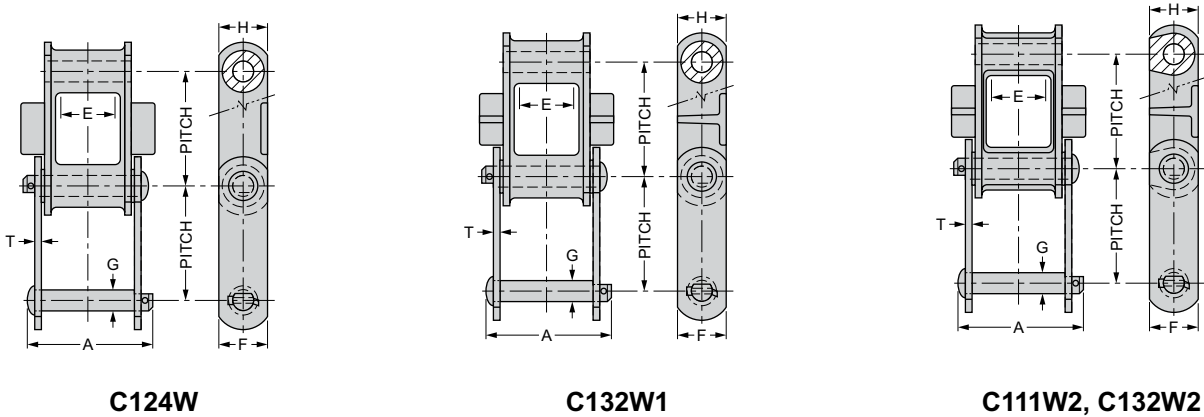

Dimensions are in inches. Strengths, loads and weights are in pounds.

Link-Belt Chain No.	Average Pitch	A	D	E	T	Sidebars	Pins	Barrel Diameter	Rated Working Load	Average Weight Per Ft.	Recommended Max. RPM for 12T Sprocket	Sprocket Unit No. ①
						F	G	H				
C111W2	4.760	5.12	2.42	.38	.44	1.75	.75	.72	5,950	11.8	55	111
C124W ②	4.063	5.12	1.69	.50	.38	2.25	.88	1.75	6,300	15.4	75	1240
C132W1	6.050	6.54	4.38	.50	.44	2.00	1.00	1.73	10,500	15.6	40	132
C132W2	6.050	6.54	4.38	.50	.44	2.00	1.00	1.73	10,500	16.0	40	132

① Cast or fabricated sprockets may be used.

② Round barrel. All other chains have an elliptical barrel. See page 55 for attachment listings.

Cast Chains

SM Combination Chains

SM Combination chains are designed primarily for high temperature applications and are extensively used for conveying steel sheets or bars through normalizing and heat-treating furnaces. The chains usually operate in channels under the floor and are thus protected from full exposure to furnace heat. The conveyed material is pushed through the furnace by fingers attached to the center links of the chain. The center links and sidebars are well proportioned for strength and rigidity. Sidebars are cast with bosses which fit into sockets in the center links. This design interlocks the center links and sidebars and relieves the pin from handling the entire working load placed on the chain.

Steel pins are heat-treated. They are free to float in the chain joint. This permits pin rotation, thus exposing the entire pin circumference to wear. It also helps correct pin bending that might occur as a result of high temperatures. The pins extend on each side of the chain to provide a mounting for outboard rollers. Rollers rotate freely on case-hardened steel bushings and are held in place by cast washers.

Clearances between all moving parts are carefully controlled by machining, to prevent binding during operation at high temperatures.

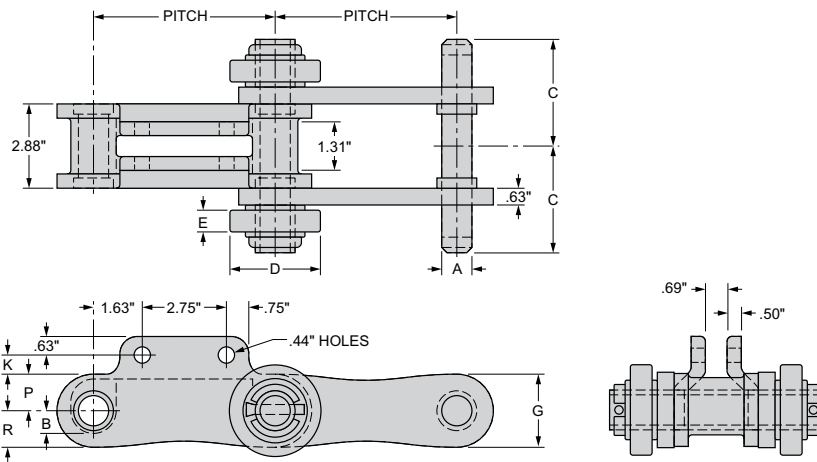
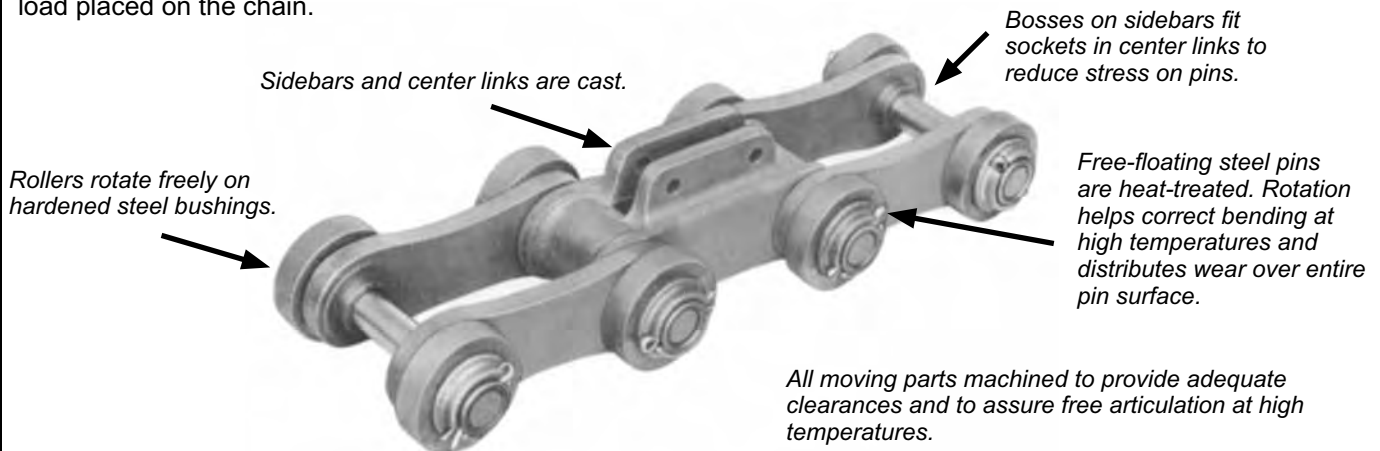

Dimensions are in inches. Strengths, loads and weights are in pounds.

Link-Belt Chain No.	Average Pitch	A	B	C	D	E	G	K	P	R	Rated Working Load	Average Weight Per Foot	Sprocket Unit No. ①
SMGL618 ②	6.000	.98	.75	3.44	3.00	.78	2.50	.72	1.19	1.19	Contact	24	SMGL618
SMGL628	6.000	1.23	1.00	3.47	3.50	.81	3.00	.53	1.38	1.38	Rexnord	31	SMGL628
SM621	9.000	Offset SM Combination Chain, Contact Rexnord										SM621	
SM622	6.000	Offset SM Combination Chain, Contact Rexnord										SM622	

① Cast or fabricated sprockets may be used.
 ② Chain with plain center link (no attachment) also available.

Cast Chains - Attachments

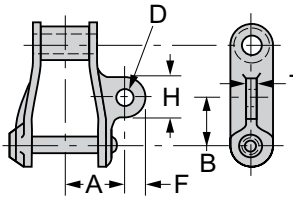

A22 (Figure 1), A42

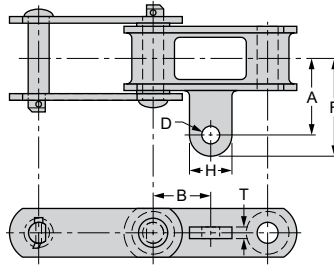

A22 (Figure 2)

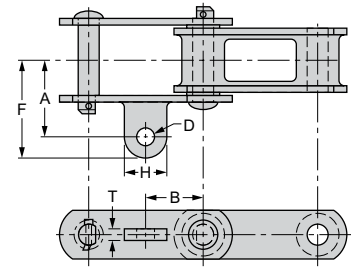

A22 (Figure 3)

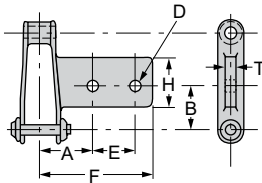

AD474

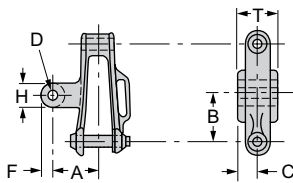

AM116

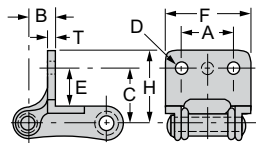

F2 (Figure 1)

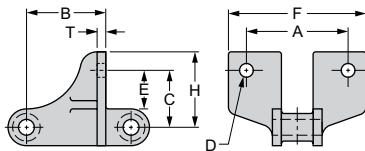

F2 (Figure 2)

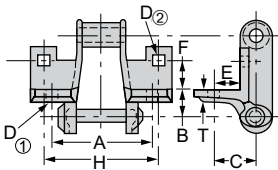

F4

Dimensions are in inches.

Chain Number	A	B	C	D		E	F	H	T
				Bolt Dia.	Bolt Hole				
A22 (Figure 1)									
H78	1.88	1.31	—	$\frac{3}{8}$.41	—	0.66	1.31	0.41
A22 (Figure 2)									
C188	1.44	1.31	—	$\frac{3}{8}$.41	—	2.08	1.19	.38
A22 (Figure 3)									
C55	1.50	.81	—	$\frac{5}{16}$.34	—	1.92	.75	.25
A42									
C9103	1.84	1.50	—	$\frac{3}{8}$.41	—	0.63	1.25	0.41
AD474									
720S	3.38	2.25	—	$\frac{1}{2}$.56	2.50	—	2.81	0.50
C720	3.38	2.25	—	$\frac{1}{2}$.56	2.50	—	2.81	0.50
AM116									
720S	2.69	3.00	0.94	$\frac{5}{8}$.69	—	0.69	1.38	1.88
C720	2.69	3.00	0.94	$\frac{5}{8}$.69	—	0.69	1.38	1.88
F2 (Figure 1)									
720S ③④	4.25	3.00	2.00	$\frac{3}{8}$.41	1.25	5.31	3.81	0.25
A730 ⑤	4.25	3.00	2.00	$\frac{3}{8}$.41	1.13	5.50	3.94	0.38
C720	4.25	3.00	2.00	$\frac{3}{8}$.41	1.25	5.31	3.81	0.25
955	1.06	0.63	0.94	$\frac{3}{16}$.22	0.50	1.81	1.25	0.16
977	1.75	0.75	1.44	$\frac{5}{16}$.34	0.94	2.63	2.00	0.25
988	2.03	1.19	1.38	$\frac{5}{16}$.34	0.90	2.90	1.97	0.28
C9103	2.22	1.25	2.00	$\frac{3}{8}$.41	1.25	3.00	2.66	0.31
F2 (Figure 2)									
C77	1.75	3.40	1.00	$\frac{5}{16}$.36	.94	2.62	1.94	.25
C102.5	5.75	2.92	2.00	$\frac{3}{8}$.44	1.13	7.12	3.07	.31
C111	6.38	3.00	2.00	$\frac{3}{8}$.44	1.13	7.75	3.00	.34
C111 (AL)	6.38	3.00	2.00	$\frac{3}{8}$.44	1.13	7.75	3.00	.34
C131	4.69	2.13	1.69	$\frac{3}{8}$.44	.94	6.12	2.75	.44
C188	2.00	1.38	1.50	$\frac{5}{16}$.34	.94	2.75	2.18	.31
F4									
H78 ①	3.75	1.00	1.44	$\frac{3}{8}$ ②	.41	0.88	0.94	4.50	0.31

- ① Style of hole, round.
 - ② Furnished cottered only at attachment links.
 - ③ Style of hole, square.
 - ④ No's. C720S- and 720S-F2 have 2 additional holes 1.94 inches apart and 1.31 inches above first line of holes.
 - ⑤ Attachments face toward open end of link.
 - ⑥ Attachment face for these chains has cloverleaf outline instead of rectangular.
- Notes: Links with attachments on only one side are made right- and left-hand.
Furnished cottered only at attachment links.

Cast Chains - Attachments

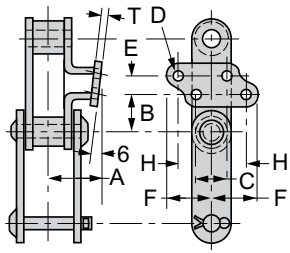

G6

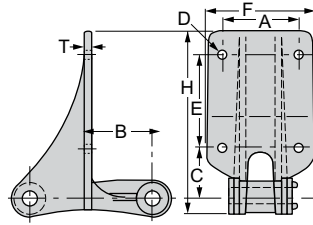

F26, 28

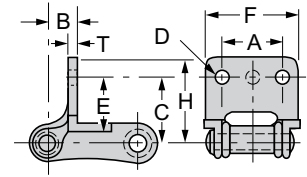

F29, F30

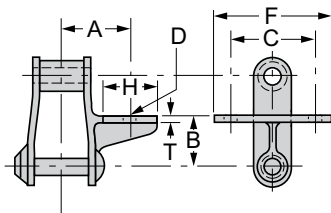

G19 (Figure 1)

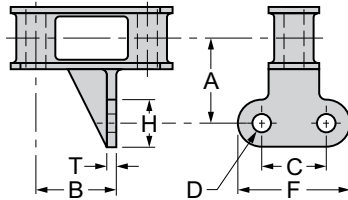

G19 (Figure 2)

Dimensions are in inches.

Chain Number	A	B	C	D ^①		E	F	H	T
				Bolt Dia.	Bolt Hole				
F26									
720S	3.75	3.00	2.38	$\frac{3}{8}$.41	2.63	5.38	6.75	0.25
C720	3.75	3.00	2.38	$\frac{3}{8}$.41	2.63	5.38	6.75	0.25
CS720S	3.75	3.00	2.38	$\frac{3}{8}$.41	2.63	5.38	6.75	0.25
F28									
720CS	3.75	3.00	2.38	$\frac{3}{8}$.41	4.50	5.38	8.84	0.25
C720	3.75	3.00	2.38	$\frac{3}{8}$.41	4.50	5.50	8.88	0.25
CS720S	3.75	3.00	2.38	$\frac{3}{8}$.41	4.50	5.38	8.84	0.25
CS730	3.75	3.00	2.38	$\frac{3}{8}$.41	4.50	5.38	8.31	0.25
F29									
C9103	2.22	0.44	2.00	$\frac{3}{8}$.41	1.25	3.06	2.66	0.41
SCA9103	2.72	2.63	2.00	$\frac{3}{8}$.41	N/A	3.06	2.66	0.38
F30									
C9103	2.22	0.63	2.00	$\frac{1}{2}$.56	1.25	3.25	2.63	0.34
SCA9103	2.22	2.44	2.00	$\frac{33}{64}$.41	—	3.25	3.63	—
G6^②									
C102.5	2.62	1.59	2.06	$\frac{3}{8}$.41	.88	2.31	3.50	.25
C131	2.19	1.26	1.68	$\frac{3}{8}$.44	.56	2.03	3.06	.28
C188	1.60	1.03	1.68	$\frac{3}{8}$.44	.56	1.91	3.06	.25
G19 (Figure 1)									
H78	2.19	1.63	2.63	$\frac{3}{8}$.41	—	3.50	1.25	0.25
G19 (Figure 2)									
C55	1.69	1.04	.88	$\frac{5}{16}$.34	—	1.75	1.00	—
C131	2.39	2.01	2.88	$\frac{3}{8}$.44	—	3.88	1.00	.28
C188	1.94	1.86	1.50	$\frac{3}{8}$.41	—	2.88	1.25	.25

① Style of hole, round.

② Right-hand attachment shown. Left-hand also available.

Note: Links with attachments on only one side are made right- and left-hand.

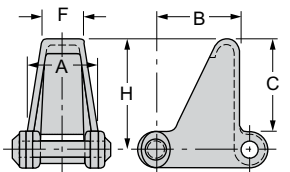

H2

Chain Number	A	B	C	D	E	F	H	T	
H2									
H78	2.38	2.31	2.94	—	—	1.06	3.50	—	

Cast Chains - Attachments

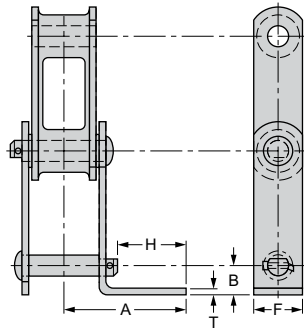

G27

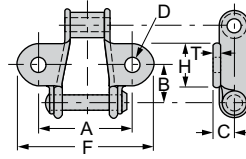

K1 (Figure 1)

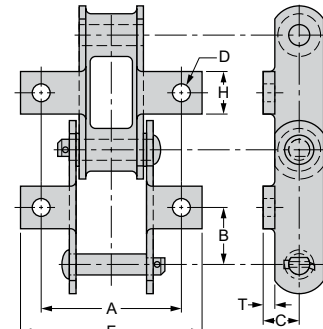

K1 (Figure 2)

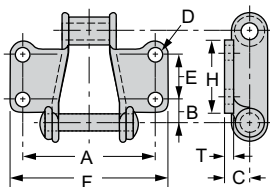

K2 (Figure 1)

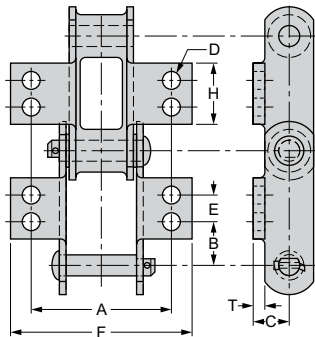

K2 (Figure 2), K3

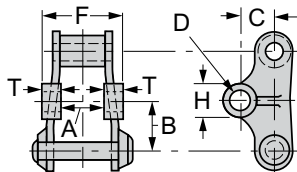

M1

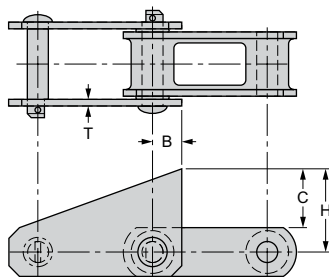

S1

Dimensions are in inches.

Chain Number	A	B	C	D		E	F	H	T
				Bolt Dia.	Bolt Hole				
G27									
C188	3.32	0.88	—	—	—	—	1.12	1.89	0.25
K1 (Figure 1)									
H78	4.00	1.25	0.81	$\frac{3}{8}$	0.41 ②	—	5.00	1.38	0.22
952	2.13	0.69	0.44	$\frac{3}{16}$	0.22 ①	—	2.88	0.75	0.16
955	2.00	0.78	0.44	$\frac{1}{4}$	0.28 ①	—	2.88	0.81	0.16
962	2.38	0.78	0.44	$\frac{1}{4}$	0.28	—	3.28	0.97	0.19
977	3.00	1.16	0.66	$\frac{1}{4}$	0.28 ②	—	3.88	1.31	0.16
988	3.81	1.31	0.66	$\frac{5}{16}$	0.34	—	4.69	1.38	0.19
C9103	4.19	1.50	0.81	$\frac{3}{8}$	0.41 ②	—	5.44	1.72	0.22
K1 (Figure 2)									
C55	2.04	0.82	0.50	$\frac{1}{4}$	0.31	—	2.92	0.82	0.16
C77	3.00	1.15	0.66	$\frac{3}{8}$	0.41	—	4.13	1.12	0.22
C131	4.12	1.54	1.00	$\frac{3}{8}$	0.44	—	5.50	1.50	0.38 ③
C188	3.75	1.31	0.81	$\frac{3}{8}$	0.44	—	5.06	1.19	0.25
K2 (Figure 1)									
H78	4.00	0.41	0.81	$\frac{3}{8}$	0.41	1.13	5.00	2.13	0.25
K2 (Figure 2)									
C102B	5.32	1.12	1.00	$\frac{3}{8}$	0.41	1.75	6.57	2.88	0.38 ③
C110	5.32	2.12	1.00	$\frac{3}{8}$	0.41	1.75	6.64	2.88	0.38 ④
C111	6.25	1.22	1.13	$\frac{1}{2}$	0.53	2.31	7.50	3.50	0.38 ⑤
C131	4.12	0.79	1.00	$\frac{1}{2}$	0.53	1.50	5.25	2.50	0.38 ⑤
C132	7.50	1.65	1.25	$\frac{1}{2}$	0.53	2.75	9.36	4.00	0.50
C188	4.18	0.68	.81	$\frac{5}{16}$	0.34	1.25	5.10	2.12	0.25
K3									
C102.5	5.31	1.14	1.19	$\frac{1}{2}$	0.53	1.75	6.55	2.88	0.50
M1									
C720	1.50	3.00	1.50	$\frac{3}{4}$	0.81	—	3.00	1.50	0.75
S1									
C102B	—	0.83	3.00	—	—	—	—	3.75	0.38
C102.5	—	1.01	2.88	—	—	—	—	3.87	0.38
C111	—	0.86	3.50	—	—	—	—	4.38	0.38
C111 W2	—	0.86	3.50	—	—	—	—	4.38	0.38
C132	—	1.13	4.00	—	—	—	—	5.00	0.50
C132 W1	—	1.13	4.00	—	—	—	—	5.00	0.50
C132 W2	—	1.13	4.00	—	—	—	—	5.00	0.50

① Style of hole, round countersunk.

② Style of hole, square.

③ Steel sidebar. Centerlink attachment is .25".

④ Steel sidebar. Centerlink attachment is .22".

⑤ Steel sidebar. Centerlink attachment is .31".

Note: Links with attachments on only one side are made right- and left-hand.
Style of hole, round. (Unless otherwise noted.)

Flight Wings Attachments

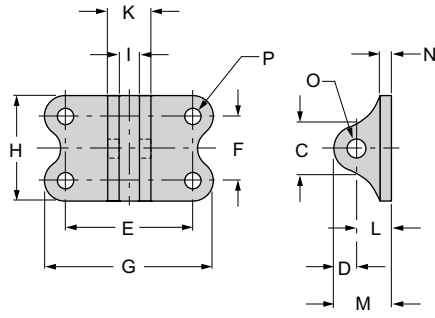

**Rexnord Style "A"
Bucket Wing**

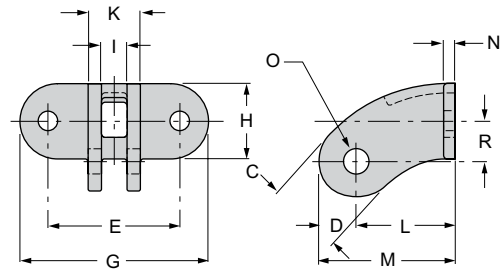

**Rexnord Style "C" & "F"
Flight Wing**

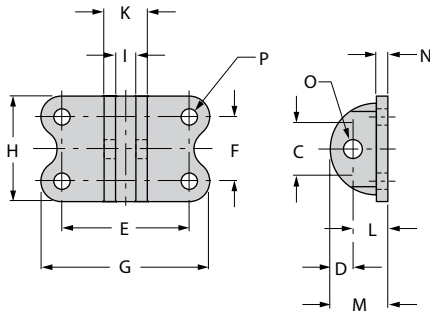

**Link-Belt
Style "A"
Bucket Wing**

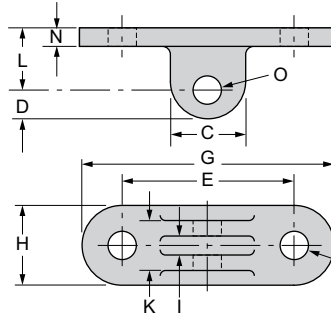

**Link-Belt
Style "B"
Bucket Wing**

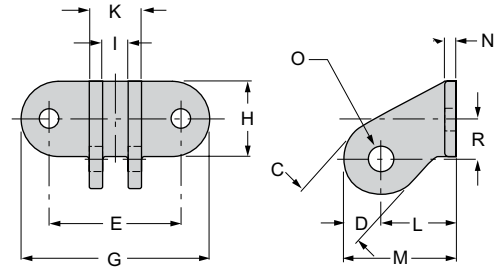

**Link-Belt
Style "C" & "F"
Flight Wing**

Dimensions are in inches. Weights are in pounds.

Rexnord Wing Number	Link-Belt Wing Number	C	D	E	F	G	H	I	K	L	M	N	O ^①	P	R	WT. Width Rivet
5A	-	1.13	.50	2.75	1.38	3.63	2.25	.44	.94	.75	1.25	.25	.38	.31	-	.6
2C	-	2.00	1.00	3.50	-	5.00	2.00	.66	1.38	2.63	3.63	.31	.63	.50	1.06	2.1
5C	-	1.69	.84	2.75	-	4.75	2.00	.56	1.31	1.38	2.22	.31	.63	.50	.81	1.3
15C	-	1.31	.50	2.50	-	3.50	1.75	.44	1.00	1.13	1.63	.28	.38	.31	.81	.7
-	4A	4.38	.69	4.00	3.26	5.50	4.76	.63	1.38	1.31	2.00	.31	.66	.56	.81	2.8
-	5A	1.25	.59	2.75	1.38	3.63	2.48	.44	.94	.75	1.34	.25	.39	.33	-	.6
-	6A	2.00	.69	3.38	1.26	4.88	2.38	.63	1.38	1.31	2.00	.31	.66	.41	-	1.3
-	30A	3.38	.88	4.00	3.50	5.50	5.00	1.09	2.25	1.44	2.32	.38	.91	.56	-	4.4
-	39A	1.25	.59	2.13	1.38	3.01	2.48	.44	.94	.75	1.34	.25	.39	.33	-	.6
-	2B	-	.41	1.76	-	2.52	.75	.28	.66	.69	-	.19	.41	.28	-	.2
-	1C	1.56	.69	3.50	-	5.00	2.00	.56	1.31	1.56	2.56	.31	.63	.56	1.00	1.6
-	2C	2.00	1.00	3.50	-	5.00	2.00	.63	1.38	2.63	3.63	.31	.63	.56	1.00	2.1
-	2C+	2.00	1.06	3.50	-	5.00	2.00	.63	1.38	3.06	4.12	.75	.66	.53	1.00	3.2
-	5C	-	.84	2.75	-	4.75	2.00	.56	1.31	1.38	2.22	.31	.66	.56	-	1.3
-	10C	.88	.44	2.13	-	3.01	.88	.28	.66	.63	1.07	.19	.34	.34	.63	.3
-	11C	1.44	.72	3.25	-	4.25	1.50	.56	1.19	1.13	1.85	.25	.66	.38	.75	.8
-	4F	1.75	-	3.50	-	6.00	2.00	-	1.063	2.50	3.13	.31	.66	.53	1.00	2.3
-	5F	3.50	.94	3.50	-	5.50	5.00	-	1.313	1.44	2.38	.38	.91	.56	-	5.00

① Swivel-rivet diameters.

Drop Forged

Standard Forged chain combines the strength and relatively light weight to make it a good choice for use with trolley, scraper flight and assembly conveyors. All forged construction with thru-hardened links and pins assures long life.

X Series chain flexes both horizontally and vertically, which makes it ideal for overhead conveyors with vertical curves.

S Series chain features a thru-hardened forged block link, induction hardened steel outer sidebars and induction hardened staked rivets for greater wear resistance, higher system tensions, and positive rivet retention.

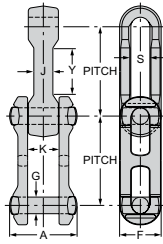

Standard Forged Chain

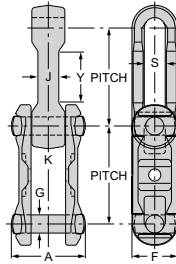

"X" Series Drop Forged Chain

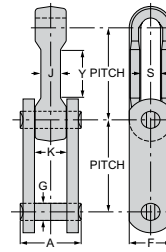

"S" Series Drop Forged Chain

Dimensions are in inches. Strengths, loads and weights are in pounds.

Rexnord Chain No.	Average Pitch	Pins		K	Chain Height	Link Thickness	S	Rated Working Load	Average Weight	Chain Part	Brinell Hardness	Average Ultimate Strength	Sprocket Unit No. ①
		G	A										
Standard Forged Chain													
468	4.031	0.75	3.31	1.69	1.88	1.13	0.88	5,800	7.8	Side Link Center Link Pin	311 / 388 331 / 388 340 / 415	88,000	468
698 ③	6.031	1.13	3.75	1.63	2.59	1.00	1.25	25,000	12.5	Side Link Center Link Pin	311 / 388 331 / 388 340 / 415	175,000	698
998 ③	9.031	1.13	3.75	1.69	2.66	1.00	1.25	25,000	10.3	Side Link Center Link Pin	311 / 388 331 / 388 340 / 415	175,000	998
9118	9.031	1.38	4.88	2.13	3.00	1.31	1.50	35,000	16.3	Side Link Center Link Pin	302 / 363 302 / 363 311 / 363	1250,000	9118 ②
"X" Series Drop Forged Chain													
X348	3.015	0.50	1.75	0.81	1.09	0.50	0.56	2,000	1.9	Side Link Center Link Pin	302 / 341 302 / 341 341 / 388	40,000	348
X458 ③	4.031	0.63	2.19	1.06	1.38	0.63	0.69	4,000	3.1	Side Link Center Link Pin	311 / 388 331 / 388 363 / 415	57,000	458
X678 ③	6.031	0.88	3.03	1.38	2.00	0.81	1.00	7,100	6.5	Side Link Center Link Pin	311 / 388 331 / 388 340 / 415	125,000	678
"S" Series Drop Forged Chain													
S348	3.019	0.50	1.75	0.81	1.13	0.50	0.56	2,000	2.4				348
S458	4.031	0.63	2.06	1.06	1.38	0.63	0.69	4,000	3.5				458
S468	4.031	0.75	2.94	1.69	2.00	1.13	0.88	6,700	7.9				468
S678	6.031	0.88	3.00	1.44	2.00	0.81	1.00	7,700	8.6				678
S698	6.031	1.13	3.25	1.63	2.50	1.00	1.25	10,800	11.7				698
S998	9.031	1.13	3.25	1.69	2.50	1.00	1.25	10,800	12.1				998

① Cast or fabricated sprockets may be used.

② Available only as a fabricated sprocket.

③ Available with 8642 alloy steel. Increases hardness and ultimate strength. Contact Rexnord for details.

Drop Forged - Attachments

Chain Number	Attachments Available
S348, X348	A53, S2
S458, X458	A22, A52, F2A, M9, S22, extended pin
468, S468	F2A, F2C, S2, extended pin
S678, X678	A22, A53, F2C, F2F, G47, K2, extended pin
698, S698	A53, A54, F2D, G2-2A, extended pin
998, S998	A42, F2A, G1B, S2A, S22, extended pin
9118, S9118	S22

Attachment Pins

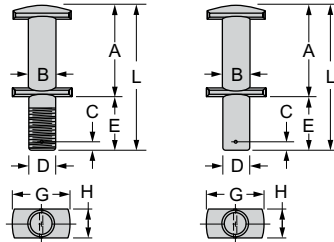

Dimensions are in inches. Strengths, loads and weights are in pounds.

Chain Number	Style	A	B	C	D	E	G	H	L	Extension (Diameter)
X348	1	1.72	0.50	0.25	0.50	1.00-2.00	1.19	0.50	A + E	0.50 Threaded
458	1	2.20	0.63	0.25	0.50	1.13-2.63	1.22	0.63	A + E	0.50 Threaded
458	1 or 2	2.20	0.63	0.25	0.63	2.00-5.50	1.22	0.63	A + E	0.63 Threaded or Plain
468	1 or 2	3.19	0.75	-	0.75	1.38-2.63	1.69	0.77	A + E	0.75 Threaded or Plain
468	1	3.19	0.75	-	0.63	1.50-5.50	1.69	0.77	A + E	0.63 Threaded
678	1 or 2	3.00	0.88	0.25	0.63	1.00-3.00	1.88	0.88	A + E	0.63 Threaded or Plain
678	1	3.00	0.88	0.25	0.75	1.00-1.50	1.88	0.88	A + E	0.75 Threaded
678	1	3.00	0.88	-	0.88	1.50-2.25	1.88	0.88	A + E	0.88 Threaded
698, 998	1 or 2	3.88	1.13	0.50	0.75	2.00	2.50	1.16	A + E	0.75 Threaded or Plain
698, 998	1 or 2	3.80	1.13	0.31	1.13	2.00	2.50	1.13	A + E	1.13 Threaded or Plain

Coupling Pins and Washers

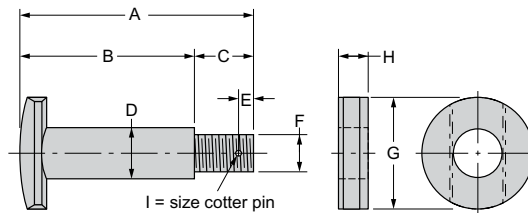

Dimensions are in inches. Strengths, loads and weights are in pounds.

Chain Number	A	B	C	D	E	F	G	H	I Cotter Size	Extension (Dia.)	Average Weight
X348	2.31	1.5	.81	0.5	0.16	0.38	1.00	0.27	0.13	0.38 dia. threaded	0.20
458	2.88	1.89	.98	0.63	0.30	0.50	1.25	0.28	0.13	0.50 dia. threaded	0.38
468	3.97	2.88	1.09	0.75	0.19	0.63	1.56	0.39	0.13	0.63 dia. threaded	0.75
X678	3.91	2.94	.97	0.88	0.25	0.63	1.88	0.50	0.13	0.63 dia. threaded	0.94
698	4.92	3.81	1.11	1.13	0.27	0.75	2.38	0.63	0.13	0.75 dia. threaded	2.00
998	4.92	3.81	1.11	1.13	0.27	0.75	2.38	0.63	0.13	0.75 dia. threaded	2.00
9118	6.09	4.97	1.13	1.38	0.25	1.00	3.00	0.69	0.19	1.00 dia. threaded	4.00

Drop Forged - Attachments

A Attachments

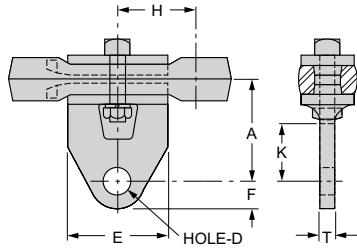

A22

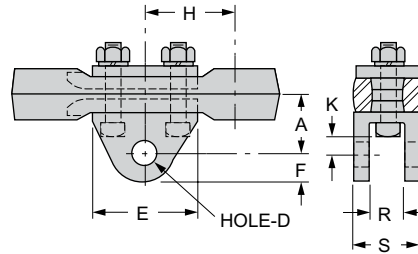

A52, A53, A54

Dimensions are in inches. Strengths, loads and weights are in pounds.

Attachment No.	Chain Number	A	D	E	F	H	K	R	S	T	Average Weight
A22	X458, S458	2.00	0.68	2.38	0.81	2.02	1.06	-	-	0.50	1.5
-	X678, S678	2.84	0.66	3.63	0.75	3.00	1.50	-	-	0.53	3.1
-	X678, S678	2.25	0.66	3.56	0.88	3.00	1.09	1.13	1.88	-	2.8
-	698, S698	2.75	0.91	4.00	0.94	3.00	1.06	1.44	2.38	-	6.0
A54	698, S698	2.50	0.66	2.97	0.88	3.00	1.13	1.13	2.00	-	4.0

F Attachments

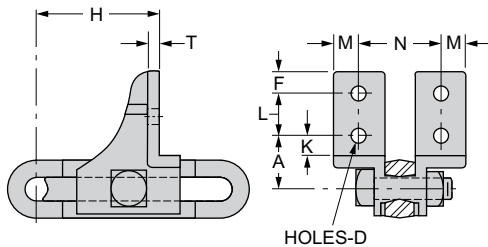

**F2C and F2F
Figure 3**

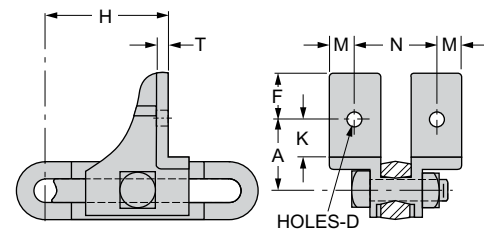

**F2A and F2C
Figure 2**

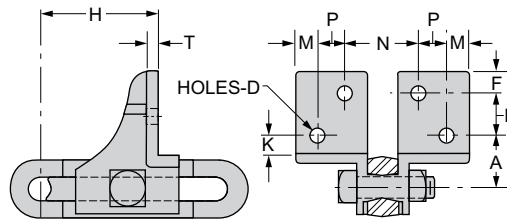

**F2A and F2D
Figure 1**

Attachment No.	Chain Number	A	D	F	H	K	L	M	N	P	T	Average Weight
F2A Figure 2	X458, S458	1.94	0.56	0.94	3.22	0.94	-	0.75	3.63	-	0.25	2.2
-	468, S468	1.97	0.56	0.75	2.78	1.00	-	0.94	4.00	-	0.31	2.5
F2D	698, S698	2.03	0.56	0.75	4.34	0.75	2.00	1.00	3.94	-	0.34	5.9

Drop Forged - Attachments

G Attachments

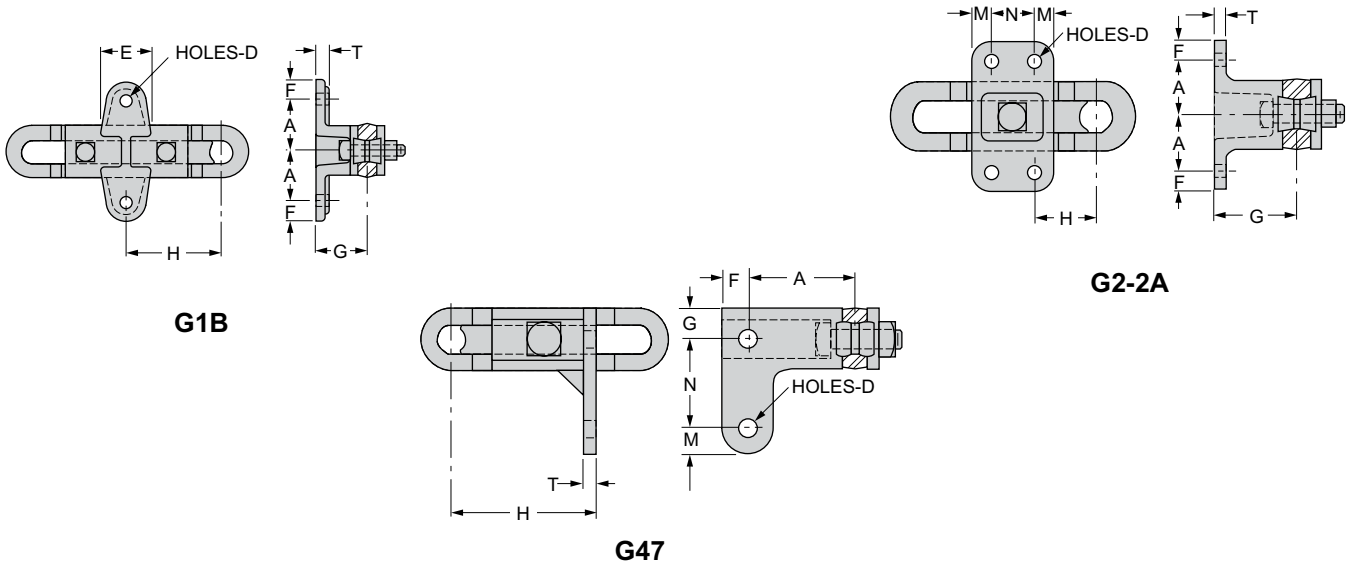

Dimensions are in inches. Strengths, loads and weights are in pounds.

Attachment No.	Chain Number	A	D	F	G	H	M	N	T	Average Weight
G1B	998, S998	2.50	0.69	1.00	2.94	2.53	1.00	4.00	0.38	11.2
G2-2A	698, S698	2.00	0.56	0.75	4.00	1.44	0.75	3.25	0.38	7.4

K Attachments

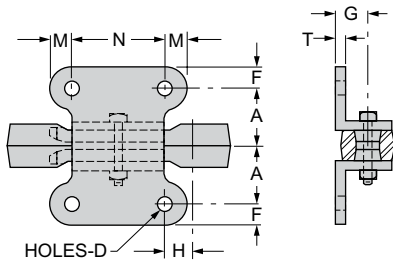

Dimensions are in inches. Strengths, loads and weights are in pounds.

Attachment No.	Chain Number	A	D	F	G	H	M	N	T	Average Weight
K2	X678, S678	1.75	0.56	0.75	1.38	1.50	0.75	3.00	0.38	3.9

Drop Forged - Attachments

S Attachments

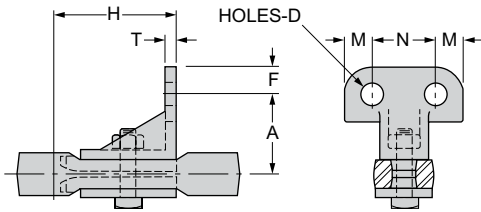

S2

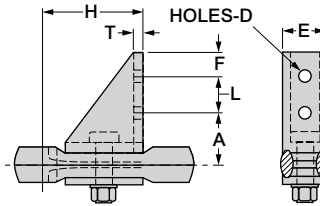

S22

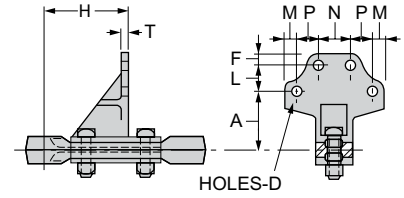

S2A

Dimensions are in inches. Strengths, loads and weights are in pounds.

Attachment No.	Chain Number	A	D	E	F	H	L	M	N	P	T	Average Weight
-	468, S468	2.69	0.56	-	0.75	2.91	-	0.75	1.50	-	0.31	1.9
S2A	998, S998	4.00	0.56	-	0.75	5.28	1.75	0.75	2.13	1.53	0.31	8.8

Live Roller Chain

Rexnord Live Roller Conveyor chains are precision conveyor carrier roller chains which may be combined with quiet running Rexnord Whisperol® polymeric rollers or with standard hexagonal axle conveyor rollers.

The conveyor chain's special Rexnord engineered hexagonal shaped hollow pin allows the chain to accept standard size hexagonal axles offered on conveyor rollers.

The combination of precision conveyed carrier roller chain and the free turning conveyor rollers produces a heavy duty roller flight conveyor which can be used as an accumulating and minimum pressure conveyor.

The combination of Rexnord Live Roller Conveyor chain with conveyor rollers is ideally suited for conveyor lines handling items which must be blocked, stopped or accumulated without stopping the conveyor.

The conveyed object, which is carried directly on the conveyor rollers, can be halted for accumulation, assembly or inspection at any location on the conveyed line. Because the conveyor rollers are free turning, line pressure is held to a minimum allowing fragile items, such as furniture, sub-assemblies, and light cartons, to be conveyed or accumulated without fear of damage.

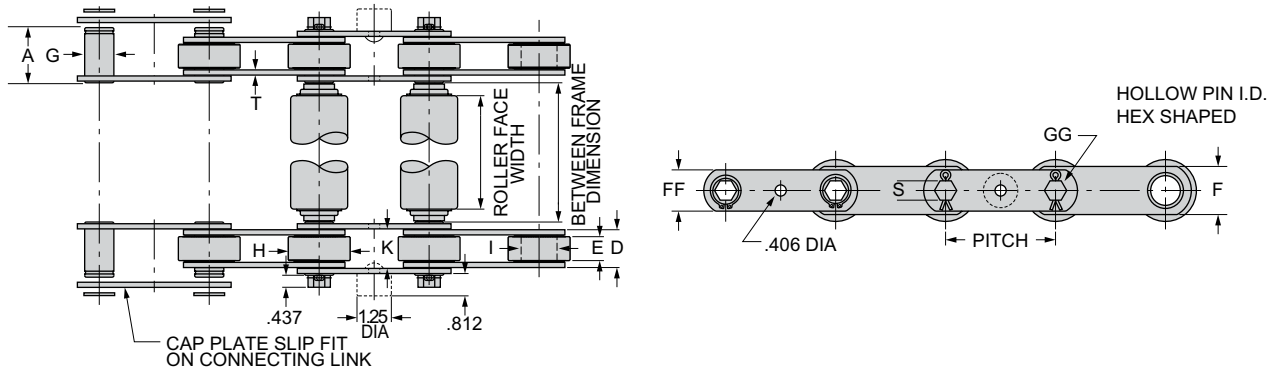

Wear lug optional, available upon request.

Dimensions are in inches. Strengths, loads and weights are in pounds.

Rexnord Chain No.	Average Pitch	Rated Working Load	Average Weight	Overall Pin	Conn. End to Center Line	Rivet End to Center Line	Between Sidebars	Thru-Hardened Sidebars				Carburized Pins		Carburized Rollers		Carburized Bushings		Sprocket Unit No.
								Thickness		Height		O. D.	Hex	Face Width	O. D.	Length	O. D.	
								Pin Link	Roller Link	Pin Link	Roller Link							
A	B	C	K	T	TT	FF	F	G	GG	E	H	D	I					
RF3007	3.000	4,000	3.9	1.78	.94	.81	1.18	.16	.19	1.13	1.31	.75	7/16	.75	1.75	1.16	.94	RF3007
RF4007	4.000	4,000	3.4	1.78	.94	.81	1.18	.16	.19	1.13	1.31	.75	7/16	.75	1.75	1.16	.94	RF4007
RF3011	3.000	5,000	6.9	2.13	1.16	.97	1.41	.19	.19	1.50	1.75	1.06	11/16	.97	2.25	1.38	1.31	RF3011
RF4011	4.000	5,000	5.7	2.13	1.16	.97	1.41	.19	.19	1.50	1.75	1.06	11/16	.97	2.25	1.38	1.31	RF4011

Note: Shaft extension for any live roller chain is A + 0.437.

Double Flex Chain

3500 Steel Double Flex Chain

Fabricated steel 3500 chain is designed to operate in either direction. This feature plus its ability to flex in two planes, and its excellent wear durability, makes it popular for a wide range of applications in the unit handling industry.

Induction Hardening

Pin bearing surfaces and all sliding surfaces are induction hardened.



Selective hardened areas provide long life, yet leave tough chain with high strength to handle big loads.

Shielded Rivets

Cupped configuration on the outer sidebar both protects and shields rivet ends, as well as provide relief for side-flex. No rivet wear prevents the possibility of disassembly while in operation.

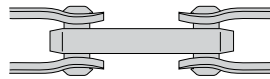

Beveled Block Link

The 3500 block link is beveled to provide additional protection for conveyors handling plastic cases.

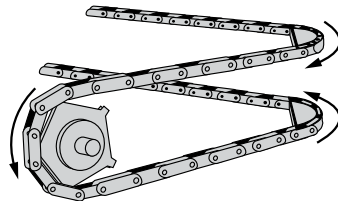

Large Sliding Area

3500 Double Flex chain presents solid, substantial sliding surfaces to channel tracks.

Nearly 50% greater sliding bearing area than drop forged chain results in lower sliding bearing pressure, thus decreasing wear on chain and channels. Again, increased chain life, lower chain replacement costs.

Make multiple turns in one run, saving on transfer points. It flexes around 20" radius corners, assuring more compact plant layouts.

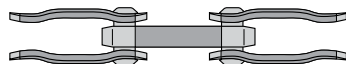

Fewer terminal units mean lower cost installations and easier maintenance.

3500 Fabricated Steel Sprockets

These sprockets can be furnished split, solid and bronze bushed. Heat treated keys are recommended.

Flanged idler wheels available, specifications and price on application.

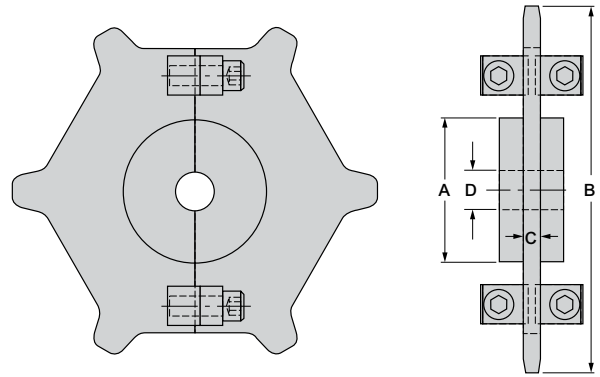

Split

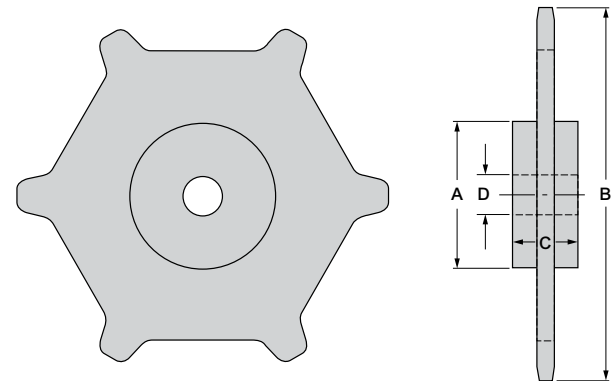

Solid

Dimensions are in inches. Weights are in pounds.

No. of Teeth	No. of Pitches	Pitch Diam.	Hub Diam.		Hub Length ①	Max. KS Bore ②	Approx. Weight Each	
			A	B			Split	Solid
5	10	8.90	4.00	9.75	2	2.44	14.5	12.5
6	12	10.63	4.50	11.50	2	2.69	20.5	18.5
7	14	12.36	5.00	13.31	2	2.94	25.5	23.5
8	16	14.10	5.00	15.25	2	2.94	31.0	29.0
9	18	15.84	5.00	16.88	2	2.94	38.5	36.0

① Overall width of split sprocket is 2⁵/₈ inches.

② Stock bore is 1¹/₄ inches.

Double Flex Chain

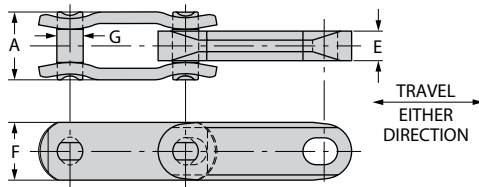

3500 STEEL CHAIN

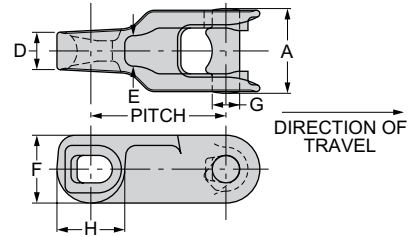

9250 CAST CHAIN

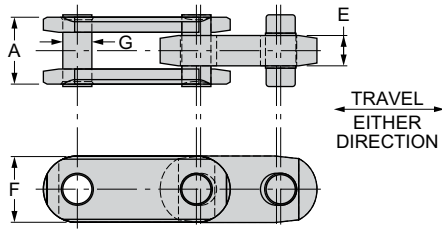

3498 STEEL CHAIN

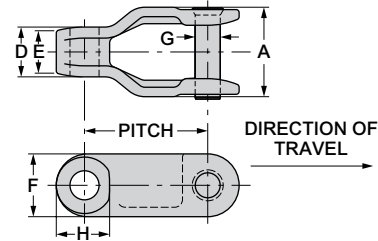

SM120 CAST CHAIN

Dimensions are in inches. Loads and weights are in pounds.

Rexnord Chain No.	Average Pitch	Rated Working Load ①	Overall Width	Length of Barrel	Max. Allowable Sprocket Face	Height of Sidebar	Diameter of Pin or Rivet	Diameter of Barrel	Minimum Flex Radius	Average Weight	Sprocket Unit No.
			A	D	E	F	G	H	R		
3500 ②	2.5 ③ 3.0	See Table Below	1.50	—	.63	1.25	.56	—	20	3.3	3500
9250	2.5	900	1.56	.69	.75 ④	1.25	.50	1.25	18	3.3	9250
SM120	2.5	1,100	1.78	1	.75 ④	1.25	.50	1.13	36	3.6	9250
3498	1.75 2.5 ⑤	See Table Below	1.44	—	.63	1.38	.63	—	16	4.5	3498
3914	3.12	See Table Below	1.50	—	.64	1.25	.56	—	22	3.2	3914
B3910	3.00	See Table Below	1.47	-	.64	1.25	.56	—	23	3.2	3910

Ratio of Chain Speed (FPM) to Conveyor Length (Ft)	Rated Working Load – Pounds	
	3500 Chain	3498 Chain
0.1 to 0.6	4000	5000
1.0	3400	4250
1.5	2900	3650
2.0	2600	3250
2.5	2300	2850
3.0	2100	2600
3.0 to 15.0	2100	2600

- ① Refer to page 107 for use of "Rated Working Load" in conveyor chain selection.
- ② When chain is to be run in channel, 2" x 1" x 3/16" (2.32 lbs. per foot), standard bar channel is suggested.
- ③ Block link is 3-inch pitch and outside link is 2 1/2" pitch.
- ④ Face on drive side of tooth.
- ⑤ Block link is 1.75" pitch and outside link is 2 1/2" pitch.

Note: For ratios below 0.1 and above 15.0, contact Rexnord for recommended rated working load. In applications without static operating conditions (shock loads), a service factor must be applied to provide for dynamic fluctuations. Speed Factors are found on page 108 or contact Rexnord. Design Working Load = Pm x Service Factor x Speed Factor.

Chain Interchange

The following tables can be used to interchange Rexnord and Link-Belt chains. Details on chains included in the listings can be found in the Engineered Steel and Cast chains sections of this catalog. To interchange Drive chains see pages 34-35. To interchange Standard Series Cast Combination chains see page 51.

In some cases, Rexnord and Link-Belt brands will couple but this should not be assumed. Attachments should be compared by catalog data rather than number. For interchange verification or assistance, contact Rexnord.

Chains are listed in numerical order. To find the desired chain follow down the first column to the number of the chain to be replaced.

Rexnord To Link-Belt Interchange

Rexnord Chain No.	Link-Belt Chain No.	Catalog Page	Rexnord Chain No.	Link-Belt Chain No.	Catalog Page	Rexnord Chain No.	Link-Belt Chain No.	Catalog Page
4	RS4019	10	531	RS4328	10	FR1222	SS1222	13
6	RS6238	11	RR588	RS887	10	FR1233	SS1233	13
81X	RS81X	10	RR778	RS886	10	C1288	SS1088	10
81XH	RS81XH	10	SR844	SBS844	14	1535	SBS2162	14
81XHH	RS81XHH	10	RO850	SBO850 Plus	14	1536	SBS1972	14
ER102B	SBS102B	14	ER856	SBX856	14	1539	RS1539	10
ER102.5	SBS102.5	14	ER857	SBX2857	14	BR2111	RS944 Plus	11
ER110	SBS110	14	ER859	SBX2859	14	A2124	RS996	11
ER111	SBS111	14	ER864	SBX2864	14	2126	RS1116	11
ER131	SBS131	14	ER911	RS911	12	2183	RS951	11
ER150	SBS150 Plus	14	ER922	SS927	12	FX2184	RO2184	11
SR183	RS3013	10	FR922	SS922	12	2188	RS2188	10
S188	SBS188	14	FR933	SS933	12	2190	RS2190	11
SR194	RS4216	10	SR1114	RS1114	11	A2198	RS960	11
SR196	RS6018	11	RR1120	RS4013	10	3420	RS1113	10
270	SS2004	10	RS1131	RS1131	11	X4004	RS4852	12
RR362	RS625	10	E1211	RS1211	13	R4009	RS4851	12
RR432	RS627	10	ER1222	SS1227	13	4065	RS4065	12
1030	ROA40	34	R1037	ROA40 HYP	34	1240	ROA1240	34
R432	ROA1622	34	R778	ROA881	34	R588	ROA882	34
R1033	ROA1031	34	R1035	ROA1032	34	R1248	ROA1242	34
R514	ROA2010	34	AX1568	ROA2512	34	RX238	ROA2814	34
3120CM	ROA3120	35	3125	ROA3125 HYP	34	3140	ROA3140	35
RX1245	ROA3315	34	RO635	ROA3618	34	RX1207	ROA4020	34
A1309	RO7080	35	3160CM	ROA3160	35	X1311	RO6555	34

Link-Belt To Rexnord Interchange

Link-Belt Chain No.	Rexnord Chain No.	Catalog Page	Link-Belt Chain No.	Rexnord Chain No.	Catalog Page	Link-Belt Chain No.	Rexnord Chain No.	Catalog Page
RS81X	81X	10	SS922	FR922	12	SS2004	270	10
RS81XH	81XH	10	SS927	ER922	12	SBS2162	1535	14
RS81XHH	81XHH	10	SS933	FR933	12	RS2188	2188	10
SBS102B	ER102B	14	RS944 Plus	BR2111	11	RS2190	2190	11
SBS102.5	ER102.5	14	RS951	2183	11	RO2184	FX2184	11
SBS110	ER110	14	RS960	A2198	11	SBX2857	ER857	14
SBS111	ER111	14	RS996	A2124	11	SBX2859	ER859	14
SBS131	ER131	14	SS1088	C1288	10	SBX2864	ER864	14
SBS150 Plus	ER150	14	RS1113	3420	10	RS3013	SR183	10
SBS188	S188	14	RS1114	SR1114	11	RS4013	RR1120	10
RS625	RR362	10	RS1116	2126	11	RS4019	4	10
RS627	RR432	10	RS1131	RS1131	11	RS4065	4065	12
SBS844	SR844	14	RS1211	E1211	13	RS4216	SR194	10
SBO850 Plus	RO850	14	SS1227	ER1222	13	RS4328	531	10
SBX856	ER856	14	SS1222	FR1222	13	RS4851	R4009	12
RS886	RR778	10	SS1233	FR1233	13	RS4852	X4004	12
RS887	RR588	10	RS1539	1539	10	RS6018	SR196	11
RS911	ER911	12	SBS1972	1536	14	RS6238	6	11
RO6555	X1311	34	ROA1031	R1033	34	ROA1032	R1035	34
ROA40	1030	34	ROA1242	R1248	34	ROA2010	R514	34
ROA40 HYP	RO1037	34	ROA2512	AX1568	34	ROA2814	RX238	34
ROA124	1240	34	ROA3120	3120CM	35	ROA3125 HYP	3125	34
RO622	R432	34	ROA3140	3140CM	35	ROA3315	RX1245	34
ROA881	R778	34	ROA3618	RO635	34	ROA4020	RX1207	34
ROA882	R588	34	RO7080	A1309	35	ROA3160	3160CM	35

Italic part numbers are obsolete.

The ER series replaces the S, ES, RS, X and SX series chains.

Sprockets

Sprocket Types

Sprockets can be supplied in various materials and styles, depending upon the application and severity of service requirements. For most engineered chain applications, fabricated steel sprockets are recommended as offering the best combination of performance, availability, and price. Fabricated steel sprockets can be provided for every chain-tooth combination and are readily available.

Sprockets can also be supplied in various cast materials, with or without hardened teeth. The cast sprocket tables present the available patterns for producing cast sprockets.

Whatever the types selected, our sprockets are designed for proper chain-sprocket interaction. Rexnord engineers have selected the proper tooth pressure angle, pitch line clearance, bottom diameter and tooth pocket radius for optimum performance and service life.

Sprocket Styles

Cast Arm Body – This type of sprocket is generally used where larger sizes are required. The use of arms reduces weight, facilitates handling, and lowers cost.

Cast Split (Arm or Plate) Body – The split body design facilitates mounting and removal from shafts without disturbing bearings or other connected equipment, which greatly reduces installation and downtime.

Cast Plate Body – Plate bodies are generally required for the smaller sizes where the use of arms is impractical, and on larger sizes when the chain pull exceeds the strength of the arm body sprockets.

Fabricated Steel Sprockets – Fabricated steel sprockets are flame cut and manufactured from plain carbon steel. The teeth are flame or induction hardened.

Shear Pin – A sprocket is modified by the addition of shear pin hubs and shear pins. They are used in applications where jamming or overloading is prevalent. The shear pins are designed to transmit the required torque under normal operating conditions, but to fail when an overload or jam occurs, thus protecting machinery and equipment from damage.

Special Sprockets – Sprockets can be made of special design, such as flanged-rim (used particularly in the rock products and fertilizer industries). Long-tooth or gapped-tooth sprockets can also be made.

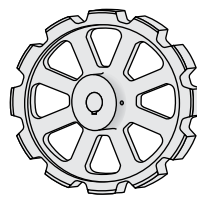

Cast Sprocket
Arm Body

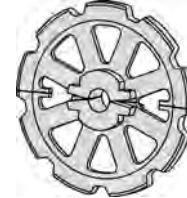

Cast Split
Arm Body

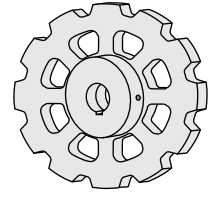

Cast Steel
Plate Body

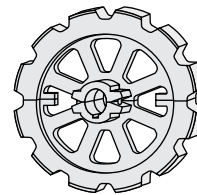

Fabricated Steel with
Lightening Holes

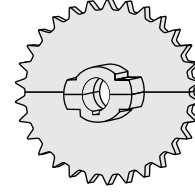

Fabricated Steel
Split Sprocket

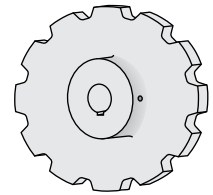

Fabricated Steel
Plate Body

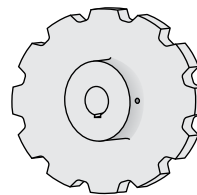

Shear Pin
Sprocket

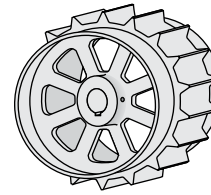

Drum Flanged Arm
Body Sprocket

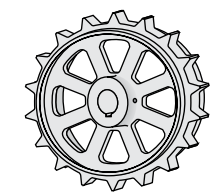

Flanged Rim
Sprocket

Segmental Sprockets and Traction Wheels

Can be supplied with either solid or split bodies, and have removable and replaceable sprocket segments or traction wheel rims. Rims are made of specially hardened steel for superior wear resistance. Accurate machining and precisely drilled holes permit sprocket segments to be reversed, thus doubling sprocket life and minimizing downtime.

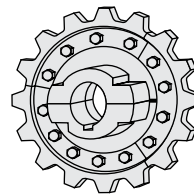

Segmental
Sprocket with
Split Body

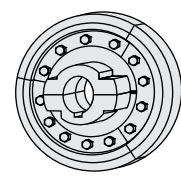

Segmental Traction
Wheel with
Split Body

Traction Wheels

Primarily designed for single-strand bucket elevator service, traction wheels can also be used on other type conveyors providing the coefficient of friction is sufficient under normal load to allow the traction wheel to drive the unit. A distinct advantage of a traction wheel is that the chain will slip on the wheel in the event of an obstruction or overload, thereby preventing damage to elevator or conveyor components. Traction wheels are ideal for service in abrasive environments since there is less scrubbing of the chain on a traction wheel as compared to sprocket.

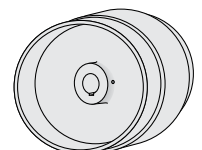

Sprockets

Selection, Specification and Ordering Information

Number of Teeth

Sprockets preferably should have no less than 12 teeth, particularly if speeds are high and the chain loads great. Sprockets having less than 12 teeth should be adapted only to slow and medium speeds. The number of teeth and sprocket speed (revolutions per minute) control the amount of impact of the chain seating on the sprocket. Impact is reduced as the number of teeth is increased or as speed is decreased. Likewise the chain pull is reduced as the sprocket size is increased for any one power drive. Consequently, a lighter chain - for greater economy - may often be used. With a greater number of teeth angular motion or friction in the chain joints is reduced.

Height of Teeth

Height of teeth for standard sprockets is generally based on providing a working face that will accept the maximum amount of wear elongation combined with a smooth topping curve. A further limitation that takes precedence over the above is that when a sprocket series is capable of being used with chains designed for conveyor/elevator service, the top of the tooth of all standard sprockets having ten or more teeth is designed to be low enough to clear a slat or carrier mounted on the lowest possible "K" attachment of any chain using sprockets of that series.

As a precaution, it is recommended that orders for sprockets specify whether it is necessary for the top of the tooth to clear any slat, bucket or carrier mounted to a chain attachment, or welded to the chain.

Bore and Hub Size

The size of the bore and hub are determined by the torque to be transmitted. The hub specification charts included in this catalog provide selections based on a design shear stress of 6000 psi, maximum.

Gapped Sprockets

Some attachments require gapped sprockets to avoid interference between the sprocket and chain or assembled fittings. Such attachments usually are those wherein the space between sidebars is utilized by the attachment or its fitting. The gap spacing must be a multiple of the particular attachment spacing in the chain, also of the number of teeth on the sprocket.

When some teeth must be topped off (that is, omitted) as distinguished from gaps that extend within the root diameter, it will be assumed that topping off the teeth flush with the root diameter will suffice to clear the obstruction. If gaps are required, complete details must accompany the order.

Heat Treatment

Fabricated steel sprockets are normally supplied with induction hardened teeth. Cast sprockets, if hardened, are either induction hardened or cast as chill iron. The catalog cast sprocket tables identify cast sprockets with hardened teeth.

Rexnord takes an extra step when heat treating segmental sprockets and tractions wheels to provide the utmost in hardness and case depth.

Prior to induction hardening, segmental rims are "soaked" with carbon in large carburizing pits specifically designed for this purpose. The carburizing process provides deep penetration of carbon into the segment's working surfaces, thereby increasing its hardenability.

After the carburizing process, the segments are taken to induction heat treat area where the segments are enveloped in a large electrical coil, heated to a "cherry red", and quickly quenched. This final process produces the hardest, deepest cases available in an engineered sprocket or traction wheel today.

The carburizing/induction heat treatment process is standard for most of our segmental sprockets and traction wheels. If you have issues with extreme sprocket wear, this extra step may be the solution. Contact Rexnord to find out if this process is available for your particular sprocket type; not all sizes and styles are available.

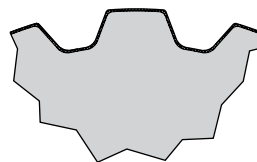

Relative depth of hardened material developed from flame, induction or chill rim hardening methods.

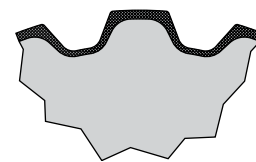

Relative depth of hardened material developed through the two-step carburizing/induction hardening process used in our segmental sprockets and traction wheels. More hardened material means longer sprocket and chain life.

Sprockets

Selection, Specification & Ordering Information – (Cont'd.)

Web Holes

Large plate or web-body sprockets can be furnished, when specified, with holes for hoisting slings or hooks. Such holes may necessitate an extra charge.

Weights

Listed weights represent averages only and may differ from those of the sprockets furnished, because of the differences in hub sizes. Average weights do not necessarily indicate the relative strengths of the various sprockets. They are given primarily for estimating shaft loads and freight charges. All weights are based on arm body construction.

Style Plate-Body or Arm-Body Construction

It will be noted that the smaller sprockets in each series (both stock and order-size) are furnished only with plate-body. Lack of space between the hub and the sprocket rim makes it impractical to furnish these sprockets with arm-body construction. All stock and order sizes will be furnished plate body. For arm body design, contact Rexnord.

Hubs

All hubs are furnished long central (style C) unless specified by the customer or if footnoted in the tables. Depending on how mounted, offset hubs or flush one side (style B) may be preferable for driver sprockets mounted on gearbox output shafts. Offset hubs are where hubs are not of equal length. If other than long central hubs are desired, be sure to specify this on the order.

All hubs are given a squaring cut, (faced) then sprockets are finish bored. Facing is provided as follows:

	Cast Hubs	Fabricated Hubs
Long Central	Faced 1 side	Faced both sides
Flush 1 side	Hub faced	Hub faced
Offset hubs	Faced both sides	Both hubs faced

Bore

Sprockets are bored to commercial tolerances (see table below). Closer tolerances are available at extra cost.

Bore Range	Tolerance (Inches)
Up thru 2.000	+ .001/+ .003
Over 2.000 thru 4.000	+ .001/+ .004
Over 4.000 thru 6.000	+ .001/+ .005
Over 6.000	+ .001/+ .006

Keyseat and Keyscrews

Standard straight keyseats on the centerline of a tooth are finished with one setscrew over the keyseat and one at 90°.

Multiple Sprocket Alignment

On a multiple strand conveyor or elevator, it is important that driving sprocket teeth be properly aligned in service. It is recommended that drive sprockets be ordered in sets with keyseats properly located relative to the teeth. Sprockets ordered as matched sets will be match marked. Sprockets are to be installed such that all match marks face the same end of the shaft.

At the tail end of a multiple strand conveyor, only one sprocket should be fixed (keyed or set screwed) to the shaft. The remainder of the tail sprockets should be allowed to turn freely on the shaft to compensate for differences in strand length that may change over time.

- Sprockets with Hubs Central
Order should specify "Matched in Sets of Two," "Matched in Sets of Three," etc.
- Sprockets with Unequal Hubs
If sprockets will be installed with like hubs all facing the same end of the shaft, the order should specify "Matched in Line."

If sprockets will be assembled with like hubs facing opposite ends of the shaft, the order should specify "Matched in Pairs."

Sprocket Availability

Fabricated Steel sprockets (split or solid) are readily available and most any sprocket design can be provided. For the quickest possible delivery, Rexnord maintains an inventory of plates and hubs for many commonly used sprockets.

Cast sprockets with solid hubs are identified in the cast sprocket tables. The sprocket is bored and keyed to order. Split sprockets, sprockets with hub dimensions other than shown, or sprockets with any other non-standard feature are available but must be cast to order. If delivery is an important factor, fabricated steel sprockets are recommended.

Sprockets

Selection, Specification & Ordering Information – (Cont'd.)

How To Order

1. Quantity
Number of sprockets required.
2. Sprocket Unit Number and Chain Number
Refer to the chain and sprocket index
3. Teeth
Number of teeth on sprocket.
4. Material
Cast or fabricated steel should be specified. Standard materials will be provided unless specified.
5. Heat Treatment
Fabricated steel sprockets will have induction hardened teeth. Cast sprockets will have hardened teeth if specified in the cast tooth sprocket tables. Specify any non-standard heat treatments.
6. Hub Construction
Hubs will be provided as standard with solid hubs, long central (Style C) unless specified otherwise. Refer to page 70 for standard hub specifications.
7. Hub Size
Cast Sprockets:
Cast tooth sprockets are listed in the tables on page 72-79 with hub dimensions and a maximum bore. Sprockets with hub or bore dimensions other than as shown require a Cast To Order sprocket. These special sprockets are available but if lead time is a factor, consider using a fabricated steel sprocket which is more readily available.

If no hub size is specified by the customer, the standard hub will be provided unless the shaft exceeds the maximum allowable bore, in which case a cast to order sprocket will be necessary.

For Cast To Order sprockets: If no hub size is specified, a hub will be selected appropriate for the shaft size and most readily available from the foundry.

If desired, hub sizes may be specified on Cast To Order sprockets, refer to the selection procedures on pages 72-79.

8. Hub Size
Fabricated Steel Sprockets:
For fabricated steel sprockets, most any size hub is readily available. When delivery is especially critical, standard hub sizes are recommended. Standard fabricated steel hubs as shown in the table on page 70 will be provided unless specified on the order.
9. Bore
Specify size and type of bore. Standard tolerances will be provided unless specified.
10. Keyseat and Setscrews
A keyway with two setscrews will be provided on all sprockets unless specified otherwise.
11. Previous Order or Quotation
Provide information regarding previous order or quotation to assure compliance.
12. Gapped Sprockets
Specify chain attachment used and spacing.
13. Drop Forged Chain Sprockets
Specify number of actual teeth
14. Shear Pin Sprockets
Specify torque level sprockets should shear. A bore size must be specified.

Sprockets

Fabricated Steel Sprockets

Listed below is the plate thickness for each sprocket unit. Refer to chain and sprocket index to determine proper unit number for each chain.

All sprockets are readily available as fabricated steel, including the wide mill chain sprocket. Fabricated assemblies for traction wheel are also readily available.

Plate Size

Sprocket Unit No.	Plate Width Inches	Sprocket Unit No.	Plate Width Inches	Sprocket Unit No.	Plate Width Inches
4	.63	698	1.25	X1365	2.75
6SP	1.13	710	2.25	1535	1.00
25	.38	720S	1.13	1536	1.25
32	.50	CS720S	1.13	B1537	1.25
34	.50	A730	1.13	1568	1.25
42	.56	CS730	1.13	1604	.88
45	.63	823	1.13	1654	2.00
51	.56	825	1.25	E1822	1.75
S51	.56	830	1.25	F1822	1.00
52	.63	833	2.25	F1833	1.25
55	.63	844	2.25	E1836	2.00
57	.63	847	1.75	F1844	1.50
D60	.88	RO850	2.00	F1855	1.50
H60	.63	SX850	2.00	1903	3.00
62	.75	856	2.75	2047	1.25
64S	1.25	859	3.25	2064	2.25
67	.63	RS860	1.75	2111	1.25
78	.88	864	3.25	2113	1.12
H78	1.00	SX877	2.50	2124	1.25
102B	1.75	SX886	2.25	2136	1.75
102-1/2	1.75	E922	1.75	2180	1.13
103	1.13	E911	1.25	F2183	1.00
106	1.75	F922	1.13	2198	1.25
110	1.75	E928	1.75	2231	.63
111SP	2.25	E933	2.00	2236	1.75
111	2.25	F933	1.25	2342	1.50
114	1.13	S951	1.00	2348	1.25
119	3.50	952	.63	2397	1.75
SM120	.75	953	1.25	2405	1.50
H124	1.50	958	2.75	2452	2.50
130	1.00	984	3.50	2590	2.50
131T	1.50	998	1.25	2614	2.25
132	2.75	1030	1.25	2800	1.50
R133	1.25	1036	1.25	2804	3.00
152	.75	1039	1.50	2806	4.00
183	.75	1112	.88	2848	1.75
SX175	2.75	1113	1.13	2858	1.75
183	.75	1120	.75	2868	1.75
188	1.00	1124	.88	RF3007	.63
194	1.00	1131	1.25	RF3011	.88
196	1.00	1204	2.00	3112	1.00
197	1.13	1207	2.25	3125	1.25
238	1.25	E1211	1.25	D3125	1.25
270	1.00	E1222	1.75	3285	1.75
303	.38	F1222	1.00	3433	1.75
X345	1.75	F1232	1.25	4004	2.25
348	.63	E1233	2.00	4005	1.13
458	.88	F1233	1.25	RF4007	.63
468	1.50	1240	1.75	4009	1.75
501	.75	E1244	2.25	4010	2.75
506	.75	FR1244	1.50	4011	2.00
508	.88	1251	1.75	RF4011	.88
514	1.25	1301	2.50	4038	1.25
520	.88	RO1305	2.25	4539	1.25
A522	.75	1306	2.50	4855	2.25
S521	1.25	1307	2.75	5157	2.75
531	1.13	A1309	2.75	5208	1.75
CA550	.63	X1311	2.75	6065	2.50
568	1.25	AX1338	1.25	6121	3.50
584	1.50	X1343	1.50	6826	2.00
589	1.13	X1345	1.50	7539	1.25
CA620	.88	X1351	1.75	8755	2.75
635	1.75	X1353	2.00	9118	1.75
678	1.13	RO1355	2.25	9250	.75
		RO1356	2.50	9856	2.50

Available in cast, see pages 72-79.

70 (5050)

Sprocket Weight

$$\text{Total Sprocket Weight} = [.22 (\text{PD})^2 \text{PW}] + W$$

PD = Pitch Diameter of Sprocket

PW = Plate Width of Sprocket (See table at left)

W = Hub Weight (See table below)

Calculated weight is an approximate to be used for estimating shaft loads and shipping weights.



Style "A" Hub



Style "B" Hub

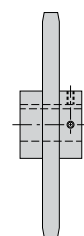

Style "C" Hub

Table Instructions

When using the tables below, and only the torque or Hub Size Letter is known, locate the appropriate row which will give you the recommended bore and hub size based on the limitations of typical **Shaft** material having a maximum torsional shear stress of 6,000 psi. If the shaft size is known, use the bore diameter column to find the recommended hub dimensions.

Solid Hubs

Dimensions are in inches. Strengths and weights are in pounds.

Bore Diameter ①	Hub Letter ②	Maximum Torque ③	Hub Diameter	Length ④	Weight ⑤
1 ⁵ / ₁₆	B	1.0	2.50	1.50	1.0
1 ³ / ₁₆	C	2.0	2.50	1.50	1.0
1 ⁷ / ₁₆	D	3.5	2.50	1.50	2.7
1 ¹¹ / ₁₆	E	5.6	3.00	1.50	3.7
1 ¹⁵ / ₁₆	F	8.5	3.00	1.50	3.7
2 ³ / ₁₆	G	12.5	3.50	2.00	6.0
2 ⁷ / ₁₆	H	17.0	4.50	2.00	10.0
2 ¹¹ / ₁₆	I	23.0	4.50	2.00	10.0
2 ¹⁵ / ₁₆	J	30.0	4.50	2.00	10.0
3 ³ / ₁₆	K	38.0	5.25	3.00	20.0
3 ⁷ / ₁₆	L	47.0	5.25	3.00	20.0
3 ¹¹ / ₁₆	M	60.0	6.00	3.00	26.0
3 ¹⁵ / ₁₆	N	70.0	6.00	3.00	26.0
4 ⁷ / ₁₆	O	100.0	7.25	4.00	46.0
4 ¹¹ / ₁₆	—	120.0	7.25	4.00	46.0
4 ¹⁵ / ₁₆	P	140.0	7.25	4.00	46.0
5 ⁷ / ₁₆	Q	190.0	8.75	5.00	85.0
5 ¹⁵ / ₁₆	R	245.0	8.75	5.00	85.0
6 ¹ / ₂	S	320.0	9.50	6.50	115.7

Split Hubs

Dimensions are in inches. Strengths and weights are in pounds.

Bore Sizes	Maximum Torque	Hub Length	Bolt Clearance Diameter	Weight
1 ⁵ / ₁₆ — 2 ¹⁵ / ₁₆	30	2.88	7.50	20.0
3 — 3 ¹⁵ / ₁₆	70	2.88	8.75	27.0
4 — 4 ¹⁵ / ₁₆	140	3.88	10.75	57.0
5 — 5 ¹⁵ / ₁₆	245	4.88	11.50	80.0

① See instructions above.

② Hub letter — From Drive Chain Selection tables.

③ In-Lbs. (in thousands)

④ Add plate thickness for length through bore (see table at left); Hubs furnished long central unless specified by customer.

⑤ Weight shown for solid hub. Actual weight should be reduced by bore.

Note: Contact Rexnord for larger bores.

Sprockets

Fabricated Steel Sprockets And Octagonal Tail
Wheels For Heavy Duty Welded Steel Drag Chains

Drive Sprockets

Rexnord Unit Number	Number of Teeth	Pitch Diameter	Outside Diameter	Tooth Width "T" Inches	"T" Average Plate Only Weight Lbs.
5157	6	12.10	12.10	2.75	93
	7	13.94	14.11		127
	8	15.81	16.13		166
	9	17.69	18.16		209
	10	19.58	20.18		256
	11	21.47	22.20		308
6121	8	23.50	23.94	3.50	360
	9	26.30	26.95		440
	10	29.12	29.96		550
	11	31.95	32.40		680

Sprockets listed are the most common. Any number of teeth are readily available. Split sprockets are available.

Unit No. 5157 for WHX 5157 Chain

Finished Bore Range Inches	Solid Hub Dia. x Length Inches	Average Hub Only Weight Lbs.
2 - 4	6 x 5.50	15
4 - 5	7.25 x 6.50	25
5 - 6	9 x 7.75	50

Unit No. 6121 for WHX 5121/6121/6067 Chain

Finished Bore Range Inches	Solid Hub Dia. x Length Inches	Average Hub Only Weight Lbs.
2 - 4	6 x 5.50	15
4 - 5	7.50 x 6.50	25
5 - 6	9 x 7.75	50
6 - 7	10.50 x 8.50	100
7 - 8	11.50 x 10.50	130

Octagonal Tail Wheels

Octagonal tail wheels offer several advantages over conventional sprockets. Chain/tail wheel forces are transmitted directly between sidebars and the octagon surfaces, eliminating barrel and sprocket tooth wear. Side guide lugs are provided to keep the chain centralized on the tail wheel.

Octagon plates and guide lugs are made of hardened steel. Sidebar contact surfaces can be hardfaced for maximum wear resistance.

Rexnord Chain Number	Bottom Flat "B" (Inches)	Width "W" (Inches)
WHX5157	11.85	6.50
WHX6067	18.88	7.50
WHX5121/WHX6121	18.88	9.00

Finished Bore Range (Inches)	Hub Dia. x Length (Inches)
0 to 3.937	6 x 5
4 to 4.937	7.25 x 6.50
5 to 5.937	9 x 7.75

Flame Cut Steel Sprocket with Hardened Teeth

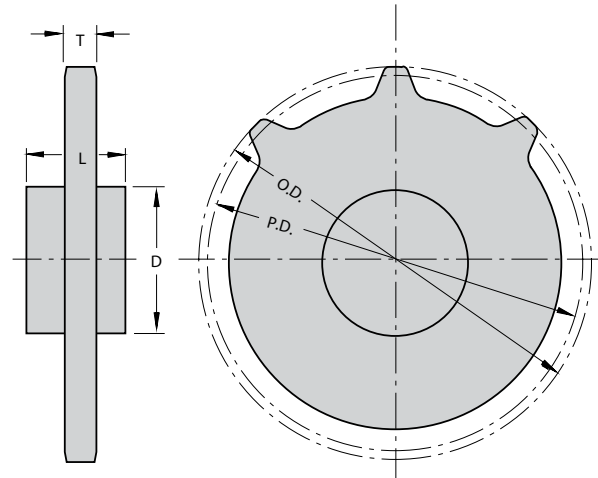

Teeth are hardened to Rc57

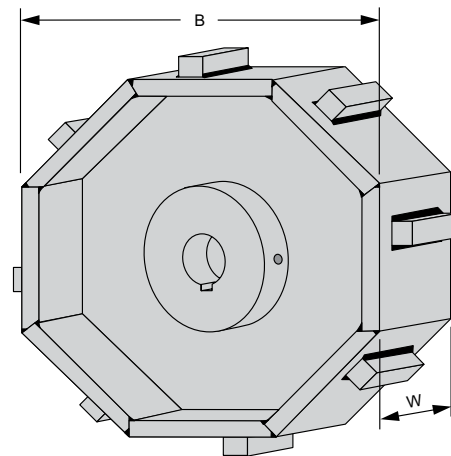

Direction Of Travel

Chain No. 5121 Chain No. 6121, 6067, 5157

Sprockets

Cast Sprockets

Cast to Order Hub Specifications

The following table provides recommended hub specifications for use when ordering cast to order sprockets.

Procedure

If torque and bore size are known:

1. Locate torque in left hand column. The next column over gives the minimum hub length.
2. Locate bore size in top row.
3. The intersection of the top row and the column selected in Step 1 is the minimum hub O.D.

If only torque is known:

1. Locate torque in left hand column. The next column over gives the minimum hub length.
2. Move to the right to the first number shown (this is the minimum hub O.D.).
3. Move vertically to the top row to determine the minimum bore.

Hub Sizes are Based on Use with Commercial Cold Finished Steel Shafting and Keys ①

Dimensions are in inches. Strengths are in pounds.

Key Size	Bore																																						
	Width	1/4	1/4	3/8	3/8	1/2	1/2	5/8	5/8	3/4	3/4	7/8	7/8	1	1	1 1/4	1 1/4	1 1/2	1 1/2	1 3/4	1 3/4	2	2	2	2 1/2	2 1/2													
	Height	1/4	1/4	3/8	3/8	1/2	1/2	5/8	5/8	3/4	3/4	7/8	7/8	1	1	1 1/4	1 1/4	1 1/2	1 1/2	1 3/4	1 3/4	2	2	2	2 1/2	2 1/2													
Hub Size Letter	Allowance Torque	Hub Length ②	Squared Key											Flat Key																									
			Diameter of Hubs - Keyseated																																				
A	500	1 1/2	1 1/2	2	2 1/2	2 1/2	3	3 1/2	4	4	4 1/2	5																											
B	1,000	1 1/2	1 1/2	2	2 1/2	2 1/2	3	3 1/2	4	4	4 1/2	5	5 1/2																										
C	2,000	1 1/2		2	2 1/2	2 1/2	3	3 1/2	4	4	4 1/2	5	5 1/2	5 1/2																									
D	3,500	2			2 1/2	2 1/2	3	3 1/2	4	4	4 1/2	5	5 1/2	5 1/2	6																								
E	5,600	2				3	3 1/2	3 1/2	4	4	4 1/2	5	5 1/2	5 1/2	6	6 1/2																							
F	8,500	3					3 1/2	3 1/2	4	4	4 1/2	5	5 1/2	5 1/2	6	6 1/2	7 1/2																						
G	12,500	3						4	4	4 1/2	4 1/2	5	5 1/2	5 1/2	6	6 1/2	7 1/2	8																					
H	17,000	3							4 1/2	4 1/2	5	5	5 1/2	5 1/2	6	6 1/2	7 1/2	8	9																				
I	23,000	4								4 1/2	5	5	5 1/2	5 1/2	6	6 1/2	7 1/2	8	9	9 1/2																			
J	30,000	4									5	5	5 1/2	5 1/2	6	6 1/2	7 1/2	8	9	9 1/2	10																		
K	38,000	5										5	5 1/2	5 1/2	6	6 1/2	7 1/2	8	9	9 1/2	10	10 1/2																	
L	47,000	5											6	6	6 1/2	6 1/2	7 1/2	8	9	9 1/2	10	10 1/2	11																
M	60,000	5												6 1/2	6 1/2	7	7 1/2	8	9	9 1/2	10	10 1/2	11	12															
N	70,000	6													6 1/2	7	7 1/2	8	9	9 1/2	10	10 1/2	11	12	12														
O	100,000	6															7 1/2	8	8 1/2	9	9 1/2	10	10 1/2	11	12	12	13												
P	140,000	6																8 1/2	9	9 1/2	10	10 1/2	11	12	12	13	13	14											
Q	190,000	8																	9	9 1/2	10	10 1/2	11	12	12	13	13	14											
R	245,000	8																		9 1/2	10	10 1/2	11	12	12	13	13	14											
S	320,000	8																			10	10 1/2	11	12	12	13	13	14											
T	400,000	10																				11	12	12	13	13	14	14											
U	500,000	10																					12	12	13	13	14	14											
V	600,000	10																						13	13	14	14	15											
W	720,000	12																							14	14	15	15											
X	850,000	12																								15	15	16											
Y	1,000,000	12																									16	16											
Z	1,250,000	12																										17											

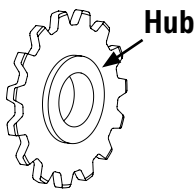

When torque and bore intersect in one of these blank spaces, it indicates that the shaft is subject to greater than 6,000 psi torsional shear stress.

① Design shear stress = 6,000 psi.
 ② These lengths are the minimum recommended; longer hubs can be furnished at additional cost. For drives, offset hubs, one side flush, are recommended for all driver sprockets.
 Notes: Long central hubs are recommended for all Driven sprockets. For improved system performance – fabricated steel sprockets are recommended over cast.
 For a sprocket without a keyseat, a smaller hub may be used. Contact Rexnord for assistance.

Sprockets

Cast Sprockets – (Cont'd.)

Cast Split Hubs – For Cast to Order Tooth Sprockets and Traction Wheels

(Hub sizes are based on use with commercial, cold finished, steel shafting and keys. ①)

Use of Tables. After having determined torque and knowing the required bore, refer to Table No. 1, below, to obtain the hub identification number.

Hub dimensions are listed in Table No. 2, below. The hub over-all length (F) – see drawing to the right – is definitely fixed for a given sprocket or wheel pattern and bore. It is determined by standard fixed hub pattern projections (D) and pattern body thickness (E) – the latter depending on the sprocket or traction wheel pattern involved. When length F must be maintained or known, refer to the factory for certified dimensions.

These hubs are furnished central and of fixed length only.

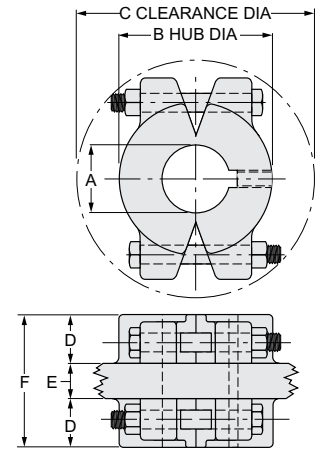

Table No. 1 – Hub Number for Given Class and Bore

Dimensions are in inches. Strengths are in pounds.

Bore	1 ⁵ / ₁₆	1 ³ / ₁₆	1 ⁷ / ₁₆	1 ¹¹ / ₁₆	1 ¹⁵ / ₁₆	2 ¹ / ₁₆	2 ⁷ / ₁₆	2 ¹¹ / ₁₆	2 ¹⁵ / ₁₆	3 ¹ / ₁₆	3 ⁷ / ₁₆	3 ¹¹ / ₁₆	3 ¹⁵ / ₁₆	4 ¹ / ₁₆	4 ⁵ / ₁₆	5 ¹ / ₁₆	5 ⁵ / ₁₆
Sq. Key Size In.	1/4	1/4	3/8	3/8	1/2	1/2	5/8	5/8	3/4	3/4	7/8	7/8	1	1	1 1/4	1 1/4	1 1/2
Allow Torque ②	Hub Number																
500	L2-015	L2-103	L2-107	L2-111	L2-115	L2-203	L2-207	L2-211	L2-215	L2-303							
1,000	L2-015	L2-103	L2-107	L2-111	L2-115	L2-203	L2-207	L2-211	L2-215	L2-303	L2-307						
2,000		L2-103	L2-107	L2-111	L2-115	L2-203	L2-207	L2-211	L2-215	L2-303	L2-307	L2-311					
3,500			L2-107	L2-111	L2-115	L2-203	L2-207	L2-211	L2-215	L2-303	L2-307	L2-311	L2-315				
5,600				L2-111	L2-115	L2-203	L2-207	L2-211	L2-215	L2-303	L2-307	L2-311	L2-315	L2-407			
8,500					L2-115	L2-203	L2-207	L2-211	L2-215	L2-303	L2-307	L2-311	L2-315	L2-407	L2-415		
12,500						L2-203	L2-207	L2-211	L2-215	L2-303	L2-307	L2-311	L2-315	L2-407	L2-415	L2-507	
17,000							H2-207	H2-211	L2-215	L2-303	L2-307	L2-311	L2-315	L2-407	L2-415	L2-507	L2-515
23,000								H2-211	H2-215	L2-303	L2-307	L2-311	L2-315	L2-407	L2-415	L2-507	L2-515
30,000									H2-215	H2-303	H2-307	L2-311	L2-315	L2-407	L2-415	L2-507	L2-515
38,000										H2-303	H2-307	L2-311	L2-315	L2-407	L2-415	L2-507	L2-515
47,000											H2-307	H2-311	L2-315	L2-407	L2-415	L2-507	L2-515
60,000												H2-311	H2-315	H2-407	L2-415	L2-507	L2-515
70,000													H2-315	H2-407	L2-415	L2-507	L2-515
100,000														H2-407	H2-415	L2-507	L2-515
140,000															H2-415	H2-507	H2-515
190,000																H2-507	H2-515
245,000																	H2-515

When torque and bore intersect in one of these blank spaces, it indicates that the shaft is larger than required to transmit the torque produced by the chain operating at its working load. Use the first hub diameter below in the same column for the bore required. The correct hub length and the torque this hub will safely transmit is found in the same row as the hub diameter used.

When torque and bore intersect in one of these blank spaces, it indicates that the shaft is subject to greater than 6,000 psi torsional shear stress.

Maximum Pitch Diameter (Inches) of Sprockets or Wheels for Use Without Rim-Lugs

15	16	17	18	20	21	22	23	24	26	26	27	28	30	33	37	39
----	----	----	----	----	----	----	----	----	----	----	----	----	----	----	----	----

Table No. 2 – Standard Split Hubs

Dimensions are in inches.

Hub No.	A Bore	B	C	D	E Max.	Wt. Ea. W/Bolts	Hub No.	A Bore	B	C	D	E Max.	Wt. Ea. W/Bolts	Hub No.	A Bore	B	C	D	E Max.	Wt. Ea. W/Bolts
L2-015	1 ⁵ / ₁₆	2.00	4.31	1.38	1.13	1	L2-215	2 ¹⁵ / ₁₆	5.25	8.06	1.69	2.00	7	H2-315	3 ¹⁵ / ₁₆	7.25	11.94	2.50	2.50	–
L2-103	1 ³ / ₁₆	2.25	4.56	1.38	1.13	1	H2-215	2 ¹⁵ / ₁₆	6.00	10.31	2.13	2.00	16	L2-407	4 ⁷ / ₁₆	7.50	11.50	2.31	2.50	17
L2-107	1 ⁷ / ₁₆	3.00	5.75	1.56	1.25	4	L2-303	3 ³ / ₁₆	6.00	9.44	1.81	2.00	10	H2-407	4 ⁷ / ₁₆	8.00	13.88	2.94	2.50	33
L2-111	1 ¹¹ / ₁₆	3.50	6.38	1.69	1.25	5	H2-303	3 ³ / ₁₆	6.50	10.31	2.13	2.00	16	L2-415	4 ¹⁵ / ₁₆	8.50	12.88	2.56	2.50	28
L2-115	1 ¹⁵ / ₁₆	3.75	6.63	1.69	1.50	5	L2-307	3 ⁷ / ₁₆	6.25	9.63	1.81	2.00	10	H2-415	4 ¹⁵ / ₁₆	9.00	14.25	2.94	2.50	37
L2-203	2 ³ / ₁₆	4.25	7.25	1.69	1.50	7	H2-307	3 ⁷ / ₁₆	6.75	10.63	2.13	2.00	17	L2-507	5 ⁷ / ₁₆	9.50	14.63	1.75	2.50	37
L2-207	2 ⁷ / ₁₆	4.50	7.38	1.69	1.75	7	L2-311	3 ¹¹ / ₁₆	6.75	10.63	2.13	2.00	17	H2-507	5 ⁷ / ₁₆	10.00	17.00	3.50	2.50	65
H2-207	2 ⁷ / ₁₆	5.00	8.63	1.81	1.75	9	H2-311	3 ¹¹ / ₁₆	7.00	11.63	2.38	2.00	18	L2-515	5 ¹⁵ / ₁₆	10.00	15.00	1.75	3.00	34
L2-211	2 ¹¹ / ₁₆	4.75	7.88	1.69	2.00	7	L2-315	3 ¹⁵ / ₁₆	7.25	11.13	2.25	2.50	25	H2-515	5 ¹⁵ / ₁₆	11.00	17.50	3.44	3.00	65
H2-211	2 ¹¹ / ₁₆	5.50	8.88	1.81	2.00	15														

① Rim Lugs. Sprockets and traction wheels with plate (web) body, or small-diameter arm body, require split rim-lugs projecting on each side. When the arm body is sufficiently large, single split rim-lugs are used between the arms. Some chain attachments (as G19) will interfere with projecting split rim-lugs, thus making special construction necessary; refer to factory.

② Design shear stress = 6,000 psi

Sprockets

Cast Tooth Sprockets - (Cont'd)

No. of Teeth	Pitch Dia.	Sprockets ②			Cast to Order Max. Bore	Avg. Wt.
		Hub Dia.	Hub Length	Max. Bore		
H112 Cast – Pitch 8.000						
Tooth Face at Pitch Line 9.000 Inches						
7	18.44	-	-	-	6.94	230
8	20.90	-	-	-	③	267
H116 Cast – Pitch 8.000						
Tooth Face at Pitch Line 12.750 Inches						
7	18.44	-	-	-	-	400
8	20.90	-	-	-	6.94	325
9	23.39	-	-	-	-	460
H119 Cast – Pitch 6.000						
Tooth Face at Pitch Line 3.625 Inches						
6	12.00	-	-	-	4.44	95
H120 Cast – Pitch 6.000						
Tooth Face at Pitch Line 8.750 Inches						
6	12.00	-	-	-	5.44	130
8	15.68	-	-	-	6.94	250
9	17.54	-	-	-	-	190
10	19.42	-	-	-	-	215
H121 Cast – Pitch 9.000						
Tooth Face at Pitch Line 8.625 Inches						
8	23.52	9.50	-	6.44	-	-
H122 Cast – Pitch 8.000						
Tooth Face at Pitch Line 8.000 Inches						
7	18.44	-	-	-	-	210
H123 Cast – Pitch 9.000						
Tooth Face at Pitch Line 6.250 Inches						
8	23.52	9.50	-	6.44	-	-
H124 Cast – Pitch 4.000 (With Hardened Teeth)						
Tooth Face at Pitch Line 1.50 inches						
7	9.22	-	-	-	3.94	38
8	10.45	-	-	-	4.94	46
9	11.70	-	-	-	5.44	58
10	12.94	-	-	-	5.44	62
11	14.20	-	-	-	5.94	69
12	15.45	-	-	-	6.50	82
14	17.98	-	-	-	③	98
15	19.24	-	-	-	-	100
16	20.50	-	-	-	-	122
17	21.77	-	-	-	-	136
18	23.04	-	-	-	-	147
19	24.30	-	-	-	-	154
20	25.57	-	-	-	-	161
22	28.11	-	-	-	-	176
27	34.46	-	-	-	-	240
28	35.73	-	-	-	-	250
30	38.27	-	-	-	-	290
37	47.18	-	-	-	-	410
130 Cast – Pitch 4.000 (With Hardened Teeth)						
Tooth Face at Pitch Line 1.000 Inches						
5	6.77	-	-	-	-	18
6	8.00	-	-	-	-	21
7	9.22	-	-	-	3.94	25
8	10.45	-	-	-	4.94	32
9	11.70	5.00	4.00	3.25	③	44
10	12.94	-	-	-	-	48
11	14.20	-	-	-	-	52
12	15.45	-	-	-	-	59
13	16.71	-	-	-	-	58
14	17.95	-	-	-	-	61
16	20.50	-	-	-	-	75

No. of Teeth	Pitch Dia.	Sprockets ②			Cast to Order Max. Bore	Avg. Wt.
		Hub Dia.	Hub Length	Max. Bore		
132 Cast – Pitch 6.050 (With Hardened Teeth)						
Tooth Face at Pitch Line 2.750 Inches						
5	10.29	-	-	-	2.94	102
6	12.10	-	-	-	-	92
7	-	-	-	-	-	-
8	15.81	7.50	6.00	4.62	5.44	190
9	17.69	-	-	-	5.94	269
10	19.58	7.50	6.00	4.44	5.94	210
11	21.47	7.50	6.00	4.25	5.94	232
12	23.38	7.50	6.00	4.00	6.50	251
13	25.28	-	-	-	6.50	317
14	27.19	-	-	-	③	352
15	29.10	-	-	-	-	372
16	31.01	-	-	-	-	302
18	34.84	-	-	-	-	445
19	36.76	-	-	-	-	486
20	38.67	-	-	-	-	495
132 Drum Flanged Cast – Pitch 6.050						
Tooth Face at Pitch Line 3.000 Inches						
10	-	-	-	-	-	-
11	-	-	-	-	-	-
12	-	-	-	-	-	-
183 Cast – Pitch 3.000 (With Hardened Teeth)						
Tooth Face at Pitch Line .812 Inches						
6	6.00	4.00	3.00	2.50	2.68	11
7	6.91	-	-	-	2.68	14
8	7.84	-	-	-	2.68	16
9	8.77	-	-	-	2.94	22
10	9.71	-	-	-	2.94	25
11	10.65	-	-	-	2.94	30
12	11.59	-	-	-	3.18	32
13	12.54	5.00	4.00	3.25	3.49	38
14	13.48	-	-	-	4.94	40
15	14.43	-	-	-	5.44	45
16	15.38	-	-	-	5.94	47
18	17.28	-	-	-	-	55
19	18.23	-	-	-	③	58
20	19.18	-	-	-	-	65
25	23.94	-	-	-	-	85
38	36.33	-	-	-	-	140
188 Cast – Pitch 4.000						
Tooth Face at Pitch Line 0.937 Inches						
5	6.78	-	-	-	-	14
6	8.00	-	-	-	3.44	25
7	9.22	-	-	-	3.68	27
8	10.45	-	-	-	3.94	36
9	11.70	-	-	-	3.94	32
10	12.94	-	-	-	3.94	33
12	15.45	-	-	-	4.44	36
13	16.71	-	-	-	4.44	36
15	19.24	-	-	-	③	39
19	24.30	-	-	-	-	48
24	30.64	-	-	-	-	58

No. of Teeth	Pitch Dia.	Sprockets ②			Cast to Order Max. Bore	Avg. Wt.
		Hub Dia.	Hub Length	Max. Bore		
194 Cast – Pitch 4.000 (With Hardened Teeth)						
Tooth Face at Pitch Line 1.031 Inches						
7	9.22	-	-	-	3.18	30
8	10.45	5.50	4.00	3.62	3.68	38
9	11.70	5.50	4.00	3.62	3.94	46
10	12.94	5.50	4.00	3.62	4.44	55
11	14.20	-	-	-	4.44	62
12	15.45	5.50	4.00	3.62	4.94	70
14	17.98	-	-	-	5.44	90
15	19.24	-	-	-	③	72
19	24.30	-	-	-	-	100
196 Cast – Pitch 6.000 (With Hardened Teeth)						
Tooth Face at Pitch Line 1.031 Inches						
5	10.21	-	-	-	-	-
6	12.00	6.00	4.00	4.00	3.94	33
7	13.82	4.50	3.00	2.75	4.44	49
8	15.68	7.00	5.00	4.56	4.94	84
9	17.54	-	-	-	5.44	93
10	19.42	7.00	5.00	4.56	4.44	114
12	23.18	-	-	-	6.50	148
13	25.07	-	-	-	③	119
14	26.96	-	-	-	-	128
16	30.75	-	-	-	-	160
18	34.55	-	-	-	-	195
19	36.45	-	-	-	-	210
25	47.87	-	-	-	-	304
197 Cast – Pitch 6.000 (With Hardened Teeth)						
Tooth Face at Pitch Line 1.125 Inches						
6	12.00	6.50	5.00	4.75	4.44	56
7	13.83	-	-	-	-	61
8	15.68	6.50	5.00	4.56	4.94	90
9	17.54	-	-	-	5.44	80
10	19.42	-	-	-	5.94	95
12	23.18	-	-	-	③	115
15	28.86	-	-	-	-	178
348 Cast – Pitch 3.031 (With Hardened Teeth)						
Tooth Face at Pitch Line .687 Inches						
4	7.92	-	-	-	1.94	15
5	9.81	-	-	-	1.94	23
6	11.59	-	-	-	2.18	24
7	13.48	-	-	-	2.44	43
9	17.28	-	-	-	-	56
10	19.18	-	-	-	③	68
11	21.03	-	-	-	-	75
12	22.98	-	-	-	-	83
16	30.60	-	-	-	-	120
19	36.33	-	-	-	-	159
458 Cast – Pitch 4.031 (With Hardened Teeth)						
(With Hardened Teeth)						
Tooth Face at Pitch Line .875 Inches						
3	7.95	-	-	-	-	20
4	10.53	-	-	-	3.18	44
5	13.04	7.50	5.00	5.06	5.06	54
6	15.57	7.50	5.00	5.06	5.06	81
7	18.12	-	-	-	5.06	71
8	20.66	-	-	-	5.06	95
9	23.13	-	-	-	③	130
10	25.77	-	-	-	-	145
11	28.33	-	-	-	-	193
12	30.68	-	-	-	-	200
14	35.87	-	-	-	-	228
19	48.63	-	-	-	-	345

All dimensions given in inches and weight in pounds.
 ① Hub one side. All other hubs are long central.
 ② If no hub data is listed, sprocket is cast to order.
 ③ Contact Rexnord for maximum bore information.

Sprockets

Cast Tooth Sprockets - (Cont'd)

No. of Teeth	Pitch Dia.	Sprockets ^②			Cast to Order Max. Bore	Avg. Wt.
		Hub Dia.	Hub Length	Max. Bore		
468 Cast – Pitch 4.031						
Tooth Face at Pitch Line 1.375 inches						
4	10.53	-	-	-	3.44	36
5	13.05	-	-	-	3.44	65
6	15.57	-	-	-	5.94	100
7	18.12	-	-	-	-	92
8	20.66	-	-	-	-	118
9	23.21	-	-	-	-	148
10	25.77	-	-	-	-	160
12	30.88	-	-	-	-	240
480 Cast – Pitch 8.000 (With Hardened Teeth)						
Tooth Face at Pitch Line 11.250 inches						
6	16.00	-	-	-	7.00	250
7	18.44	-	-	-	7.50	295
8	20.90	-	-	-	③	330
9	23.39	-	-	-	-	385
10	25.89	-	-	-	-	440
480 Drum Flanged CAST (With Hardened Teeth)						
Tooth Face at Pitch Line 11.250 inches						
6	16.00	-	-	-	③	490
7	18.44	-	-	-	-	560
8	20.90	-	-	-	-	654
9	23.39	-	-	-	-	750
10	25.89	-	-	-	-	840
483 Cast – Pitch 4.000						
Tooth Face at Pitch Line .875 inches						
8	10.45	-	-	-	-	30
9	11.70	-	-	-	-	35
12	15.45	-	-	-	-	65
13	16.72	-	-	-	-	70
19	24.30	-	-	-	-	124
520 Cast – Pitch 2.563 (With Hardened Teeth)						
Tooth Face at Pitch Line .875 inches						
10	8.29	-	-	30	6.00	4
12	9.90	-	-	40	6.50	5
18	14.76	-	-	-	-	65
24	19.64	-	-	84	-	10
30	24.52	-	-	-	-	100
40	32.67	-	-	-	-	165
531 Cast – Pitch 4.000						
Tooth Face at Pitch Line 1.187 inches For Chain No. 531						
6	8.00	-	-	-	2.94	34
8	10.45	-	-	-	3.44	43
10	12.94	-	-	-	3.94	49
12	15.46	-	-	-	4.44	85
14	17.98	-	-	-	-	80
15	19.24	-	-	-	-	85
16	20.50	-	-	-	-	94
17	21.77	-	-	-	-	107
19	24.30	-	-	-	-	120

No. of Teeth	Pitch Dia.	Sprockets ^②			Cast to Order Max. Bore	Avg. Wt.
		Hub Dia.	Hub Length	Max. Bore		
678 Cast – Pitch 6.031 (With Hardened Teeth)						
Tooth Face at Pitch Line 1.187 inches						
3	12.06	-	-	-	-	50
4	15.72	-	-	-	5.44	75
5	19.52	-	-	-	-	115
6	23.24	-	-	-	③	148
7	27.03	-	-	-	-	190
8	30.83	-	-	-	-	240
10	-	-	-	-	-	-
698 Cast - Pitch 6.031 (With Hardened Teeth)						
Tooth Face at Pitch Line 1.375 inches						
5	19.52	-	-	-	6.94	122
6	23.24	-	-	-	③	162
7	26.96	-	-	-	-	200
8	30.92	-	-	-	-	275
CS720S Cast – Pitch 6.000 (With Hardened Teeth)						
Tooth Face at Pitch Line 1.000 inches						
6.5-13T	12.89	-	-	-	-	65.0
8.5P-17T	16.59	-	-	-	③	98.2
9-9T	17.51	-	-	-	-	80.0
9.5P-19T	18.48	-	-	-	-	115.3
10-10T	19.42	-	-	-	-	95.0
10.5-21T	20.33	-	-	-	-	110.0
11-11T	21.30	-	-	-	-	105.0
11.5P-23T	22.24	-	-	-	-	127.7
12.5P-25T	24.12	-	-	-	-	141.3
13-13T	25.07	-	-	-	-	130.0
16-16T	30.75	-	-	-	-	180.0
720S Cast - Pitch 6.000 (With Hardened Teeth)						
Tooth Face at Pitch Line 1.125 inches						
6P-6T	12.00	-	-	-	③	47.9
26.5P-13T	12.91	-	-	-	-	53.1
8P-8T	15.68	-	-	-	-	71.3
8.5P-17T	16.61	-	-	-	-	92.2
9P-9T	17.54	-	-	-	-	99.5
9.5P-19T	18.48	-	-	-	-	107.3
10P-10T	19.42	-	-	-	-	115.4
10.5-21T	20.33	-	-	-	-	110.0
11P-11T	21.30	-	-	-	-	98.3
11.5P-23T	22.24	-	-	-	-	118.2
12P-12T	23.18	-	-	-	-	120.0
12.5P-25T	24.12	-	-	-	-	131.5
13P-13T	25.07	-	-	-	-	138.7
15P-15T	28.86	-	-	-	-	155.0
16P-16T	30.75	-	-	-	-	180.0
19P-19T	36.45	-	-	-	-	245.9
20P-20T	38.36	-	-	-	-	267.8
CS730 Cast - Pitch 6.000 (With Hardened Teeth)						
Tooth Face at Pitch Line 1.125 inches						
9.5P-19T	18.48	-	-	-	-	114.8
11.5P-23T	22.24	-	-	-	-	113.5
12.5P-25T	24.01	-	-	-	-	127.9
18P-18T	34.55	-	-	-	-	207.0
27P-27T	-	-	-	-	-	-

No. of Teeth	Pitch Dia.	Sprockets ^②			Cast to Order Max. Bore	Avg. Wt.
		Hub Dia.	Hub Length	Max. Bore		
A730 Cast - Pitch 6.000 (With Hardened Teeth)						
Tooth Face at Pitch Line 1.125 inches						
6P-6T	12.00	-	-	-	③	47.9
8P-8T	15.68	-	-	-	-	71.3
9P-9T	17.54	-	-	-	-	85.5
9.5P-19T	18.48	-	-	-	-	107.3
10P-20T	19.42	-	-	-	-	115.4
11P-11T	21.30	-	-	-	-	105.0
11.5P-23T	22.24	-	-	-	-	104.5
12P-12T	23.14	-	-	-	-	110.8
12.5P-25T	24.12	-	-	-	-	117.9
13P-13T	25.07	-	-	-	-	125.1
13.5P-27T	26.02	-	-	-	-	132.5
14P-14T	26.96	-	-	-	-	153.7
15P-15T	28.86	-	-	-	-	170.0
16P-16T	30.75	-	-	-	-	187.2
18P-18T	34.55	-	-	-	-	225.2
24P-24T	45.79	-	-	-	-	363.5
823 Cast – Pitch 4.000 (With Hardened Teeth)						
Tooth Face at Pitch Line 1.125 inches						
8	10.45	-	-	-	2.44	25
10	12.95	-	-	-	3.18	45
11	14.20	-	-	-	3.68	54
12	15.46	-	-	-	3.94	56
13	16.71	-	-	-	4.44	60
14	17.98	-	-	-	4.94	65
16	20.51	-	-	-	5.44	81
17	21.77	-	-	-	5.94	86
18	23.04	-	-	-	5.94	91
19	24.26	-	-	-	-	95
24	30.65	-	-	-	③	138
825 Cast - Pitch 4.000 (With Hardened Teeth)						
Tooth Face at Pitch Line 1.250 inches						
10	12.94	-	-	-	6.44	58
12	15.45	-	-	-	-	78
13	16.71	-	-	-	-	82
14	17.98	-	-	-	-	94
15	19.24	-	-	-	-	112
16	20.50	-	-	-	-	115
19	24.30	-	-	-	-	140
830 Cast - Pitch 4.000 (With Hardened Teeth)						
Tooth Face at Pitch Line 1.312 inches						
6	12.00	-	-	-	6.44	58.5
8	15.68	-	-	-	③	79
9	17.54	-	-	-	-	88
10	19.42	-	-	-	-	102
11	21.20	-	-	-	-	105
11.5-23T	22.21	-	-	-	-	125
12	23.18	-	-	-	-	121
13	25.07	-	-	-	-	142
15	28.86	-	-	-	-	168
16	30.75	-	-	-	-	180

All dimensions given in inches and weight in pounds.

① Hub one side. All other hubs are long central.

② If no hub data is listed, sprocket is cast to order.

③ Contact Rexnord for maximum bore information.

Sprockets

Cast Tooth Sprockets - (Cont'd)

No. of Teeth	Pitch Dia.	Sprockets ^②			Cast to Order Max. Bore	Avg. Wt.
		Hub Dia.	Hub Length	Max. Bore		
844 Cast – Pitch 6.000 (With Hardened Teeth)						
Tooth Face at Pitch Line 2.125 inches						
6						
8	15.88	-	-	-	6.44	94
9	17.54	-	-	-	-	112
10	19.42	-	-	-	-	125
11	21.30	-	-	-	-	140
12	23.18	-	-	-	-	160
13	25.07	-	-	-	-	171
15	28.86	-	-	-	-	200
16	30.75	-	-	-	-	217
19	36.45	-	-	-	-	275
F922 Cast – Pitch 9.000 (With Hardened Teeth)						
Tooth Face at Pitch Line 1.125 inches						
6	18.00	-	-	-	5.94	74
8	23.52	-	-	-	③	150
9	26.31	-	-	-	-	160
10	29.12	-	-	-	-	175
F933 Cast – Pitch 9.000 (With Hardened Teeth)						
Tooth Face at Pitch Line 1.250 inches						
6	18.00	-	-	-	5.94	93
7	20.74	-	-	-	③	120
8	23.52	-	-	-	-	152
951 Cast – Pitch 6.000 (With Hardened Teeth)						
Tooth Face at Pitch Line 1.062 inches						
6	12.00	-	-	-	5.44	62
8	15.68	-	-	-	5.44	81
998 Cast – Pitch 9.031 (With Hardened Teeth)						
Tooth Face at Pitch Line 1.375 inches						
4	23.53	-	-	-	6.44	195
5	29.14	-	-	-	③	258
6	34.81	-	-	-	-	325

No. of Teeth	Pitch Dia.	Sprockets ^②			Cast to Order Max. Bore	Avg. Wt.
		Hub Dia.	Hub Length	Max. Bore		
1113 Cast – Pitch 4.040 (With Hardened Teeth)						
Tooth Face at Pitch Line 1.062 inches						
6	8.08	-	-	-	2.44	24
8	10.56	-	-	-	2.94	38
9	11.81	-	-	-	3.18	40
10	13.07	-	-	-	3.68	45
11	14.34	-	-	-	3.94	50
12	15.61	-	-	-	4.44	60
13	16.88	-	-	-	4.94	68
14	18.16	-	-	-	③	85
16	20.71	-	-	-	-	95
17	21.99	-	-	-	-	104
18	23.67	-	-	-	-	110
24	30.95	-	-	-	-	178
1120 Cast – Pitch 4.000 (With Hardened Teeth)						
Tooth Face at Pitch Line .687 inches						
5	6.81	-	-	-	2.18	12
6	8.00	-	-	-	2.44	23
7	9.22	-	-	-	3.68	72
8	10.45	-	-	-	3.68	29
9	11.70	-	-	-	3.94	38
10	12.94	-	-	-	3.94	40
11	14.19	-	-	-	③	50
12	15.45	-	-	-	-	65
14	17.98	-	-	-	-	77
15	19.24	-	-	-	-	86
16	20.50	-	-	-	-	97
18	23.04	-	-	-	-	115
19	24.30	-	-	-	-	125
22	28.11	-	-	-	-	165
24	30.65	-	-	-	-	190
31	39.54	-	-	-	-	244
35	44.62	-	-	-	-	322
1131 Cast – Pitch 6.000 (With Hardened Teeth)						
Tooth Face at Pitch Line 1.250 inches						
6	12.00	-	-	-	3.94	62
8	15.68	-	-	-	3.94	78
9	17.54	-	-	-	3.95	120
12	23.18	-	-	-	4.44	153
13	25.03	-	-	-	-	175
14	26.96	-	-	-	③	190
16	30.75	-	-	-	-	225
25	47.87	-	-	-	-	350
F1222 Cast – Pitch 12.000 (With Hardened Teeth)						
Tooth Face at Pitch Line 1.000 inches						
6	24.00	-	-	-	5.94	157
8	31.36	-	-	-	-	210

No. of Teeth	Pitch Dia.	Sprockets ^②			Cast to Order Max. Bore	Avg. Wt.
		Hub Dia.	Hub Length	Max. Bore		
2124 Cast – Pitch 6.000 (With Hardened Teeth)						
Tooth Face at Pitch Line E.375 inches						
6	12.00	-	-	-	-	50
8	15.68	-	-	-	6.44	62
10	19.42	-	-	-	③	95
12	23.18	-	-	-	-	133
13	25.07	-	-	-	-	150
15	28.86	-	-	-	-	186
16	30.76	-	-	-	-	220
24	45.97	-	-	-	-	250
2180 Cast – Pitch 6.000 (With Hardened Teeth)						
Tooth Face at Pitch Line 1.125 inches						
6	12.00	-	-	-	4.94	50
8	15.68	-	-	-	7.00	90
16	30.76	-	-	-	-	200
20	38.36	-	-	-	-	260
9250 Cast – Pitch 2.500 (With Hardened Teeth)						
Tooth Face at Pitch Line .750 inches						
6	5.00	-	-	-	-	5
7	5.76	-	-	-	-	9
8	6.53	-	-	-	-	10
10	8.09	4.00	3.00	2.50	2.68	13
11	8.87	4.00	3.00	2.50	2.68	16
12	9.66	4.00	3.00	2.50	2.68	18
14	11.24	-	-	-	-	23
15	12.03	-	-	-	-	28
16	12.81	-	-	-	-	30

All dimensions given in inches and weight in pounds.

① Hub one side. All other hubs are long central.

② If no hub data is listed, sprocket is cast to order.

③ Contact Rexnord for maximum bore information.

Sprockets

Cast Traction Wheels And Drum Flanged Traction Wheels

Traction Wheels are used primarily on the headshafts of bucket elevators and elevating conveyors to protect the system from obstructions. Providing the frictional grip between the chain and the traction wheel is sufficient to transmit the power under normal load. In the case of obstruction, the chain will slip on the wheel, and avoid damaging some machinery or part of the system.

Drum Flanged Traction Wheels are used on drag chain conveyors where discharge is over the head wheel.

Materials: Traction wheels are furnished cast and fabricated steel. Segmental rim traction wheels are available with fabricated bodies. See pages 81-84.

Standard Sprocket Bore Tolerances; Keyseat and Set-screws; and Hubs: See page 140 for key and set screw sizes. The corresponding paragraphs on page 121 applies to traction wheels.

To determine a wheel's pitch diameter, add to its outside diameter the barrel diameter of the chain to be used.

Note: For Replaceable Segmental-Rim Traction Wheels, see pages 81-84.

Unit No.	O. D.	x = HDN	Face Width	Drum Width	Wt.	
78	10	x	.94	—	30.0	
	12	x	.94	—	45.0	
	12.50	x	.94	—	50.0	
	13.25	x	.94	—	58.0	
	14	x	.94	—	62.0	
	15	x	.94	—	65.0	
	15.50	x	.94	—	68.0	
	16	x	.94	—	70.0	
	18	x	.94	—	75.0	
	19	x	.94	—	80.0	
20	x	.94	—	85.0		
102B	12	x	1.88	—	50.0	
	13.50	x	1.88	—	60.0	
	14	x	1.88	—	63.0	
	14.63	x	1.88	—	68.0	
	15.75	x	1.88	—	78.0	
	16.75	x	1.88	—	89.0	
	17	x	1.88	—	92.0	
	18	x	1.88	—	100.0	
	19.75	x	1.88	—	108.0	
	21	x	1.88	—	117.0	
H102	22	x	1.88	—	127.0	
	23	x	1.88	—	139.0	
	23.75	x	1.88	—	143.0	
	27.63	x	1.88	—	160.0	
	29.63	x	1.88	—	166.0	
	33	x	1.88	—	175.0	
	11.50		6.25	11.50	185.0	
	14.63		6.25	11.50	230.0	
	103	7	x	1.13	—	25.0
		9.63	x	1.13	—	38.0
14.63		x	1.13	—	49.0	
16		x	1.13	—	60.0	
17		x	1.13	—	70.0	
18		x	1.13	—	75.0	
20		x	1.13	—	90.0	
22		x	1.13	—	115.0	
22.50		x	1.13	—	125.0	
24		x	1.13	—	135.0	
H104	29.38	x	1.13	—	170.0	
	10.50		4	12	125.0	
	12.38		4	12	145.0	
	14		4	12	170.0	
	16		4	12	205.0	
	17.75		4	12	250.0	
	19.75		4	12	305.0	
	20.13		4	12	345.0	

Unit No.	O. D.	x = HDN	Face Width	Drum Width	Wt.
H110	10.25		8.88	16.38	175.0
	14		8.88	16.38	250.0
	15.88		8.88	16.38	290.0
	17.75		8.88	16.38	335.0
	19.63		8.88	16.38	365.0
	9.50	x	2.25	—	50.0
	14.56	x	2.25	—	85.0
	15.50	x	2.25	—	91.0
	18	x	2.25	—	105.0
	20	x	2.25	—	135.0
H111	22	x	2.25	—	143.0
	23	x	2.25	—	146.0
	23.75	x	2.25	—	149.0
	26	x	2.25	—	165.0
	29.50	x	2.25	—	198.0
	30.75	x	2.25	—	210.0
	16.75		9	16.50	200.0
	19.25		9	16.50	230.0
	16.88		13	20.50	395.0
	19		13	20.50	485.0
H116	21.75		13	20.50	550.0
	13.88		13	20	495.0
	16.50		13	20	560.0
	13	x	2.75	—	120.0
	13.75	x	2.75	—	124.0
	16	x	2.75	—	128.0
	16.25		2.75	14	510.0
	17	x	2.75	—	138.0
	18	x	2.75	—	147.0
	H118	18.25		2.75	14
20.25			2.75	14	620.0
21.63		x	2.75	—	186.0
22		x	2.75	—	190.0
24		x	2.75	—	205.0
26.19		x	2.75	—	210.0
27.75		x	2.75	—	225.0
30		x	2.75	—	280.0
13.88			11.13	22	440.0
16.25			11.13	22	510.0
H480	18.75		11.13	22	540.0
	21.13		11.13	22	600.0
	23.75		11.13	22	630.0

All dimensions given in inches and weight in lbs.

Unit No.	O. D.	x = HDN	Face Width	Drum Width	Wt.	
S825	10.50	x	1.25	—	45.0	
	14	x	1.25	—	60.0	
	15.50	x	1.25	—	68.0	
	16	x	1.25	—	72.0	
	17	x	1.25	—	79.0	
	18.25	x	1.25	—	86.0	
	20	x	1.25	—	95.0	
	22	x	1.25	—	105.0	
	24	x	1.25	—	120.0	
	27.75	x	1.25	—	140.0	
844	31	x	1.25	—	160.0	
	12	x	2.13	—	65.0	
	16	x	2.13	—	90.0	
	19.75	x	2.13	—	109.0	
	22.25	x	2.13	—	130.0	
	23.75	x	2.13	—	148.0	
	27.75	x	2.13	—	172.0	
	29	x	2.13	—	190.0	
	15	x	1	—	62.0	
	720	15.50	x	1	—	65.0
S856	18.25	x	1	—	85.0	
	29	x	2.75	—	170.0	
	21.50	x	2.75	—	187.0	
	26	x	2.75	—	200.0	
	27.75	x	2.75	—	218.0	
	29.50	x	2.75	—	225.0	
	30	x	2.75	—	236.0	
	8	x	.69	—	24.0	
	955	18.75	x	.69	—	65.0

Sprockets

Segmental Rim Sprockets And Traction Wheels

Segmental sprockets and traction wheels significantly reduce the labor and down time associated with replacing worn standard type units. Worn segments can be replaced one at a time without removing the chain, disassembling shaft and/or bearing assemblies or realigning hub placement.

Sprockets and traction wheel rims are made of hardened steel and may be furnished with split or solid hub bodies.

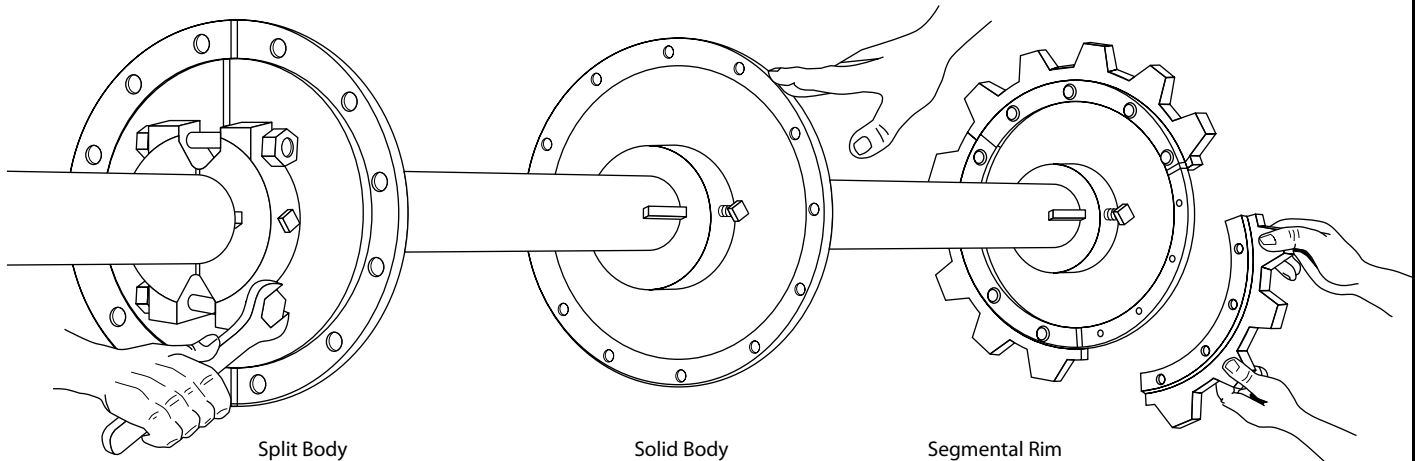

Solid Hub Bodies

Solid hub bodies are recommended for new installations. They are accurately machined of close-grained cast iron. The bodies can be made of steel, but dimensions will differ.

Split Hub Bodies

Split hub bodies can be easily installed on existing installations without removing the shaft, bearings, or chain. They are accurately machined of close-grained cast iron. A complete set of hub bolts and nuts included. The bodies can be made of steel, but dimensions will differ.

Traction Wheels vs. Sprockets at the Head Shaft

When properly applied, the use of a traction wheel at the head end of a centrifugal elevator will increase both chain and wheel life. In addition, the traction wheel will minimize peak chain tensions under impact or starting conditions.

Successful application of a traction wheel is dependent upon the frictional force between the traction wheel and the chain bushing. The friction is great enough to handle the applied chain load without excessive slippage. Factors which can detract from the effectiveness of a traction wheel are:

1. Handling material with lubricating qualities.
2. Heavy digging loads.
3. Handling very dense material.

Dry and abrasive materials, on the other hand, have the desirable effect of increasing the coefficient of friction. Traction wheels have been used very successfully in the cement mill industry. Chain with rollers should not be used with a traction wheel.

Sprockets

Segmental Rim Sprockets and Traction Wheels – (Cont'd.)

Solid Hub Bodies

Solid hub bodies are recommended for new or existing installation where it is expedient to install a solid hub to save added cost and weight of a split hub.

Solid hub bodies can be made of cast iron or fabricated steel. The outer rim of both cast and fabricated steel hub bodies is machined to exact concentricity and the flange base is machined to provide a mating surface for the rim. This insures correct fit and proper installation of segmental traction wheel and sprocket rims. Hubs are central with the center line of rims.

Fabricated steel bodies are recommended for use in severe applications, such as cement mill, to provide maximum fatigue and wear life.

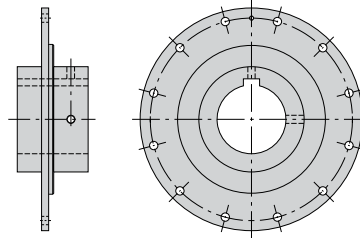

Solid Hub

Cast Solid Bodies ①

Body No. ②	Bore Size	Hub Length	Wt.
10	1.94	4.25	43
	2.44	4.25	42
	2.94	4.25	41
	3.44	6.00	63
	3.94	6.00	60
	4.44	6.00	56
12	1.94	4.25	62
	2.44	4.25	60
	2.94	4.25	58
	3.44	6.00	90
	3.94	6.00	85
	4.44	6.00	80
16	4.94	6.50	96
	1.94	3.25	80
	2.44	5.00	86
	2.94	5.00	97
	3.44	5.00	94
	3.94	6.50	139
	4.44	6.50	134
	4.94	6.50	127
	5.44	7.75	189
	5.94	7.75	180
20	6.44	8.50	225
	6.94	8.50	272
	2.44	5.00	140
	2.94	5.00	138
	3.44	5.00	134
	3.94	6.50	180
	4.44	6.50	174
	4.94	6.50	168
	5.44	7.75	229
	5.94	7.75	220
20	6.44	9.50	323
	6.94	9.50	310

Fabricated Solid Bodies

Body No. ②	Bore Size	Hub Length	Wt.
10	1.94	3.75	44
	2.44	3.75	44
	2.94	3.75	43
	3.44	3.75	41
	3.94	3.75	38
	4.44	6.50	61
12	4.94	6.50	55
	1.94	4.25	65
	2.44	4.25	63
	2.94	4.25	61
	3.44	4.25	58
	3.94	4.25	54
	4.44	6.00	87
	4.94	6.00	79
	5.44	7.75	110
	5.94	7.75	100
16	1.94	5.00	105
	2.44	5.00	103
	2.94	5.00	100
	3.44	5.00	96
	3.94	5.00	92
	4.44	7.00	116
	4.94	7.00	108
	5.44	7.00	136
	5.94	7.00	127
	6.44	8.50	178
20	6.94	8.50	165
	7.44	8.50	186
	7.94	8.50	172
	8.44	10.50	259
	1.94	5.50	157
	2.44	5.50	154
	2.94	5.50	151
	3.44	5.50	147
	3.94	5.50	142
	4.44	7.75	169
20	4.94	7.75	161
	5.44	7.75	193
	5.94	7.75	183
	6.44	8.50	225
	6.94	8.50	213
	7.44	8.50	234
	7.94	8.50	220
	8.44	8.50	247
	9.94	11.50	300

Fabricated Solid Bodies (Cont'd.)

Body No. ②	Bore Size	Hub Length	Wt.
25	1.94	5.50	250
	2.44	5.50	289
	2.94	5.50	244
	3.44	5.50	240
	3.94	5.50	235
	4.44	7.75	262
	4.94	7.75	254
	5.44	7.75	286
	5.94	7.75	276
	6.44	8.50	314
35	6.94	8.50	301
	7.44	8.50	322
	7.94	8.50	308
	8.44	11.50	414
	1.94	5.50	325
	2.44	5.50	375
	2.94	5.50	448
	3.44	5.50	444
	3.94	5.50	440
	4.44	8.50	459
35	4.94	8.50	452
	5.44	8.50	478
	5.94	8.50	469
	6.44	8.50	518
	6.94	8.50	506
	7.44	8.50	526
	7.94	8.50	512
	8.44	11.50	619

All dimensions given in inches and weight in pounds.

① Steel bodies are recommended for use with RS856, ER956, ER857, ER859, ER864, SBX856, SBX2857, SBX2859 and SBX2864 rims used in severe service such as cement mill elevators.

② Body no. represents bolt circle diameter. See page 84 for bolting information.

Sprockets

Segmental Rim Sprockets and Traction Wheels – (Cont'd.)

Split Hub Bodies

Split hub bodies can be easily installed in existing applications without removing the shaft, bearing or chain. Split hub bodies can be furnished in cast iron or fabricated steel. Complete set of hub bolts and nuts included.

The outer rim of both cast and fabricated steel hub bodies is machined to precise concentricity and the flange base is machined to provide a mating surface for the rim.

This insures correct fit and proper installation of segmental traction wheels and sprocket rims. Hubs are central with the center line of rims.

Fabricated steel bodies are recommended for use in severe applications, such as cement mill, to provide maximum fatigue and wear life.

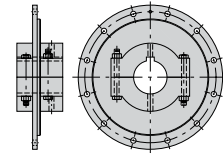

Cast Split Bodies ①

Body No. ②	Bore Size	Hub Length	Wt.
10	1.94	5.63	53
	2.44	5.63	51
	1.94	5.63	75
12	2.44	5.63	72
	2.94	7.00	125
	3.44	7.00	120
	3.94	7.00	115
	1.94	6.50	97
16	2.44	6.50	125
	2.94	7.25	168
	3.44	7.25	164
	3.94	7.25	158
	4.44	8.25	237
20	4.94	8.25	229
	1.94	4.38	126
	2.44	5.00	163
	2.94	5.00	160
	3.44	5.00	157
	3.94	6.50	235
	4.44	6.50	229
	4.94	6.50	223
	5.44	7.63	328
	5.94	7.63	319
	6.44	11.13	641
6.94	11.13	626	
7.44	11.13	610	

Fabricated Split Bodies

Body No. ②	Bore Size	Hub Length	Wt.
12	1.94	6.75	109
	2.44	6.75	105
	2.94	6.75	101
	3.44	6.75	97
	3.94	6.75	91
	4.44	7.75	134
16	4.94	7.75	126
	1.94	6.75	145
	2.44	6.75	142
	2.94	6.75	138
	3.44	6.75	133
	3.94	6.75	127
	4.44	7.75	169
	4.94	7.75	161
	5.44	7.75	212
	5.94	7.75	202
	20	1.94	6.75
2.44		6.75	195
2.94		6.75	191
3.44		6.75	186
3.94		6.75	181
4.44		7.75	217
4.94		7.75	209
5.44		7.75	271
5.94		7.75	261
6.44		9.50	361
6.94		9.50	347
25	7.44	8.75	367
	7.94	8.75	352
	8.44	8.75	430
	1.94	6.75	289
	2.44	6.75	286
	2.94	6.75	282
	3.44	6.75	277
	3.94	6.75	272
	4.44	7.75	307
	4.94	7.75	299
	5.44	7.75	359
5.94	7.75	349	
35	6.44	8.75	447
	6.94	8.75	433
	7.44	8.75	453
	7.94	8.75	438
	7.44	8.75	513
	1.94	6.75	375
	2.44	6.75	372
	2.94	6.75	487
	3.44	6.75	482
	3.94	6.75	476
	4.44	7.75	511
4.94	7.75	503	
5.44	7.75	564	
5.94	7.75	554	
6.44	8.75	652	
6.94	8.75	638	
7.44	8.75	657	
7.94	8.75	642	
8.44	8.75	717	

Body Bolting

Body No.	Bolt Quantity	Bolt Size	Bolt Torque Ft./Lbs.
10	12	5/8	180
12	12	5/8	180
16	12	3/4	320
20	24	3/4	320
25	24	1	710
35	24	1	710

Torque values based on dry conditions.

1 Ft. Lb. Torque = 1 Lb. Force With 1 Ft. Lever Arm

All dimensions given in inches and weight in pounds.

① Steel bodies are recommended for use with RS856, ER956, ER857, ER859, ER864, SBX856, SBX2857, SBX2859 and SBX2864 rims used in severe service such as cement mill elevators.

② Body no. represents bolt circle diameter.

Sprockets

Segmental Rim Sprockets And Traction Wheels – (Cont'd.)

Cast Rims

Each traction wheel rim and sprocket rim are induction case-hardened to the highest practical hardness around the entire circumference. The hardness depth is controlled to give the longest wear life, yet leaves the interior tough and ductile perfect qualities for absorbing the impact and shock loads encountered in “elevator-conveyor” service.

Segmental sprocket rims can be reversed (back side of tooth becomes the working face), in order to maximize wear life.

Segmental traction wheel rims can be easily installed, no need to even remove the chain in order to replace worn out rims. No burning or cutting is necessary.

Our “T” head traction wheel design moves the center of the chain load more closely over the body flange, thus reducing the possibility of hub fatigue problems.

Segmental rim traction wheels are split with cuts in the rims that are made diagonally. These diagonal cuts eliminate the possibility of the segments spalling or chipping at the line of split as a result of chain bushing or barrel line impact.

The sides of the segmental traction wheel & sprocket rims are chamfered to allow the chain to “enter” and “leave” smoothly without damaging the chain components.

All rims are furnished with high strength UNC thread nuts and bolts as standard.

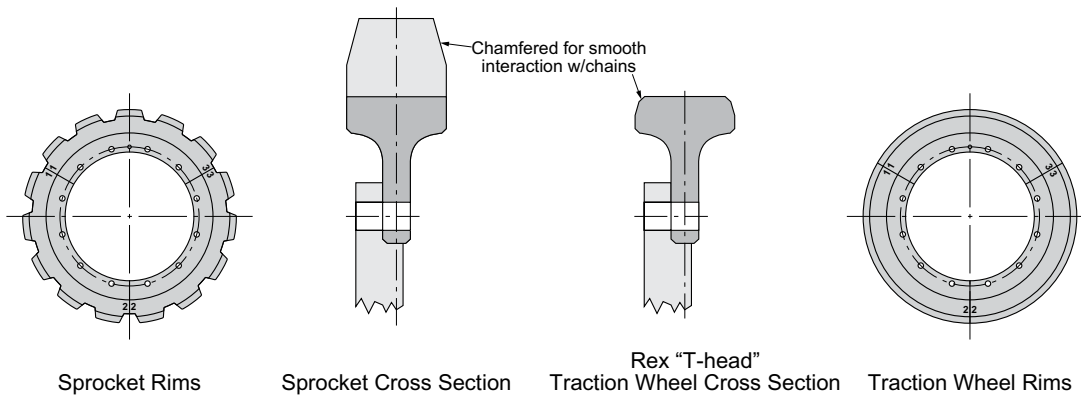

Available Cast Traction Wheel Rims (with Bolts, Washers and Nuts)

Rexnord Chain No.	Link-Belt Chain No.	Outside Diam. In.	Use Body No.	Wt. Each Lbs.	Face Width In.
A102B A102 1/2 S102 1/2 S102B S110	C102B C102 1/2 SBS102 1/2 SBS102B SBS110	24	16	115	1.75
A111 ER111	C111 SBS111	22 24 26 30	16 16 20 20	110 130 140 165	2.25
ER857 ER956 RS856 ER958	SBX2857 SBX856	20 22 24 26 28 30	12 16 16 20 20 20	90 115 145 155 170 185	2.75
ER859 ER864 ER984	SBX2859 SBX2864	24 26 30 36 42 49	16 20 20 20 35 35	165 175 175 175 235 235	3.50

Notes: Fabricated steel rims are readily available for most every chain. Contact Rexnord for more details.
Body No. represents bolt circle diameter in inches.

Buckets

Elevator Buckets



Cast Mill Duty



Cast - ACStyle

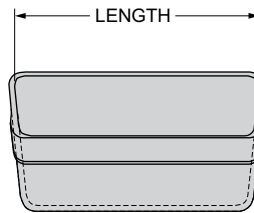
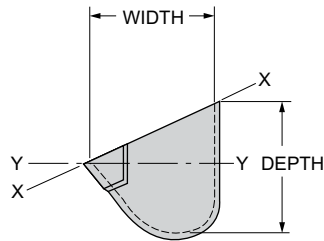

Dimensions are in inches. Weights are in pounds.

Length	Width	Depth	Back Thickness		Capacity – Cu. Ft.		Weight Cast
			Cast		(X-X)	(Y-Y)	
Mill Duty							
4	2.75	3.00	.10		.011	.007	1.3
5	3.50	3.75	.20		.020	.013	3.2
6	4.00	4.25	.20		.029	.021	4.0
7	4.50	5.00	.20		.050	.030	5.5
8	5.00	5.50	.20		.07	.044	7.1
10	6.00	6.25	.20		.12	.081	10
12	6.00	6.25	.30		.14	.087	20
12	7.00	7.25	.30		.19	.12	17
14	7.00	7.25	.30		.23	.14	18
14	8.00	8.50	.32		.30	.16	24
16	7.00	7.25	.32		.27	.16	28
16	8.00	8.50	.32		.34	.21	30
18	8.00	8.50	.32		.39	.23	39
18	10.00	10.50	.36		.53	.40	43
20	8.00	8.50	.32		.42	.28	48
24	8.00	8.50	.38		–	–	–
AC Style							
12	8.00	8.50	.38		.28	.21	25
16	8.00	8.50	.38		.38	.28	35
18	10.00	10.50	.44		.62	.49	58
24	10.00	10.50	.44		.85	.68	78

For fabricated steel buckets, please contact Rexnord.

Buckets

Punching For Use With Belts

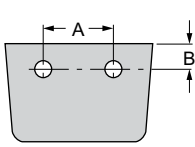

Punching B1

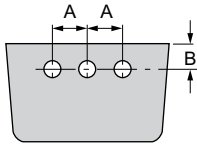

Punching B2

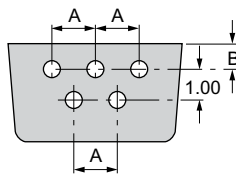

Punching B6

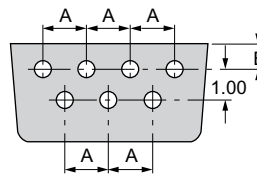

Punching B8

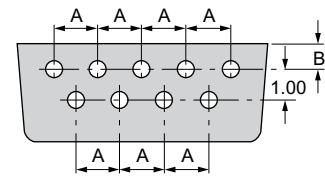

Punching B9

The bucket punching dimensions shown are Manufacturers' Standard for mill duty style and continuous style buckets.

Belt width should exceed bucket length by one inch for buckets up to 16 inches, and by two inches for buckets 16 inches or over.

Bolt diameters for all buckets are 1/4 inch for buckets up to 10 inches, 5/16 inch for buckets 10 inches or over.

Minimum length of bolts, of attaching buckets to belts, is determined as follows: Add (1) thickness of belt body (all 1/6 inch per ply), (2) total thickness of rubber covers, (3) thickness of rubber washer (allow 1/4 inch), (4) thickness of bucket back, and (5) thickness of nut (assumed equal to bolt diameter).

A rubber washer is used one each bolt, between bucket and belt, to act as a cushion when bucket passes around the pulleys, and to provide open spaces which prevent fine material from accumulating or packing between bucket and belt. Tight-fitting bolts prevent moisture from working into belt.

Dimensions are in inches.

Bucket Length	A	B	Bucket Length	A	B	Bucket Length	A	B	Bucket Length	A	B	Bucket Length	A	B
Punching B1			Punching B2			Punching B6			Punching B8			Punching B9		
4	2 ⁵ / ₁₆	3/4	7	2 ¹ / ₂	1	8	3	7/8	14	4	7/8	20	4	7/8
5	3 ³ / ₁₆	1	8	3	1	9	3	7/8	16	4 ¹ / ₂	7/8	22	4 ¹ / ₂	7/8
6	4 ³ / ₈	1				10	3 ¹ / ₂	7/8	18	5	7/8	24	5	7/8
						11	4	7/8						
						12	4 ¹ / ₂	7/8						

For continuous style buckets, centerline for single row of holes, or centerline between double row, will be at mid-depth of bucket.

Design and Selection

Selection Of Chains

The following sections of this catalog are devoted to presenting comprehensive selection procedures for drive, conveyor, and elevator chains. The information included provides economical selections, yet assures the correct choice of components which can withstand the rigors of the application. Because there is an almost unlimited variety of component applications, these selections are meant only to serve as a guide when designing new systems. On existing installations, the selection guides will prove helpful in determining whether a component in use is the most economical choice. They will also serve to guide the upgrading of present installations where service life is not satisfactory.

Rexnord Selection Services

Rexnord application engineers are available to assist in the selection of chains and components. Gather all pertinent technical information regarding the application, and call us at (414) 643-3000 or fax us at (414) 643-2609.

Chain Ratings

As a result of extensive testing and field experience, load ratings have been established for drive chains based on wear durability and fatigue strength to provide 15,000 hours chain life under the ideal conditions of clean environment, proper installation, maintenance, and lubrication. Drive chains are selected in the tables by horsepower and speed.

All other types of metal chains should be selected based on working load and chain speed limitations, with due regard for experience in similar application environments. A chain's working load is the maximum load (chain pull) a chain can withstand without a shortened life due to accelerated wear or breakage.

Rexnord and Link-Belt chains are also rated according to the Standards and Policies and Procedure Recordings of the American Chain Association. Most notably, we publish a minimum ultimate tensile strength (MUTS). This represents the minimum force at which an unused, undamaged chain could fail when subjected to a single tensile loading test.

It should be noted that chains should not be selected based on ultimate strength ratings. Design considerations chosen to maximize ultimate strengths frequently are not consistent with obtaining the best possible resistance to the modes of failure that most often limit a chain's life (e.g. low-cycle fatigue, corrosion induced embrittlement, etc.). Chains that sacrifice some degree of tensile strength to obtain greater ductility, toughness, and resistance to embrittling conditions are far better suited to most application environments.

Drive Chain Selection

Rexnord and Link-Belt drive chains of all steel construction are ruggedly built, dependable chains for service in the slow to moderate speed ranges and heavy loads. Since they operate over cast sprockets with hardened teeth or fabricated steel sprockets, and are long in pitch compared to ANSI roller chain, they are a more economical choice than other chains.

Under exposed conditions, or where dust and dirt are present, the designed, built-in clearance between the working parts of our drive chains make them very suitable for service. Conveyor and elevator drives are ideal for Rexnord and Link-Belt drive chains since they withstand heavy shock loads and exposed operating conditions.

Rexnord 3100 Series steel chain is designed to have advantages and features of our other steel chains and to be a replacement for ANSI roller chains.

Rexnord and Link-Belt drive chains are not designed for attachments. See pages 10 to 29 for chains with attachments.

General Design Considerations

Basis for Selection

Selections are based on laboratory tested and field proven horsepower capacity and speed data rather than "working loads." The horsepower capacity ratings have been developed on the basis of fatigue strength and wear capacity of the chain components. Under ideal conditions of clean environment, proper installation, maintenance, and lubrication, the selections listed are intended to provide 15,000 hours chain life for 100 pitch strands.

More economical chain selections are available. For applications where a chain life of less than 15,000 hours is acceptable, contact your Rexnord representative.

Economy

When selecting a chain drive, consider all elements, but use only those that are required for the safe and successful operation of the drive application.

In evaluating the economy of a chain-sprocket drive system, consider the overall cost of the chain and sprockets in the system and not merely the cost per foot of chain.

Chain

The best chain and sprocket combination is selected in the 12-tooth column. Occasionally, the same chain will appear under the three sprocket selections; that is 9T, 12T, and 15T. This same chain is the most economical choice of all the other chains that were considered.

Selection for 9-tooth sprockets are limited, in some cases, by commercial steel shafting. Where alloy shafting is required, see Rexnord for recommendations.

Design and Selection

Sprockets

Rexnord sprockets are designed with full attention to the requirements for proper chain-sprocket interaction. For each size and type of sprocket, Rexnord Engineers have selected the proper tooth pressure angle, pitch-line-clearance, bottom diameter and tooth pocket radius for maximum service.

Fabricated steel sprockets are recommended as the preferred choice for all chain drives. Cast sprockets with hardened teeth are also available for use on slower drives.

Largest Keyseated Bore

The "largest keyseated bore" shown in the drive chain selection tables (pages 94-102), indicates the largest shaft that may be used with the sprocket hub selected. Sprocket hubs will deliver the HP and RPM used for the selection but are not designed for the torque that could be delivered by the largest keyseated shaft shown in the table.

If a larger bore than shown is required, select a larger sprocket. The largest bore is selected from the hub size table for the material shown, either Cast Sprockets with hardened teeth or Fabricated Steel, and defines the largest hub diameter which will fit without interfering with the chain.

Chain Slack

For best operating service, allow a sag in the slack strand equal to 3% of sprocket centers.

Drive Arrangements

Relative position of sprockets in drives should receive careful consideration. Satisfactory operation can be secured with the centerline of the drive at any angle to the horizontal, if proper consideration is given. Certain arrangements require less attention and care than others are, therefore, less apt to cause trouble. Various arrangements are illustrated in the diagrams. The direction of rotation of the drive sprocket is indicated.

Best Arrangements

Arrangements considered good practice are illustrated in Figs. 1, 2, 3, and 4. The direction of rotation of the drive sprockets in Figs. 1 and 4 can be reversed.

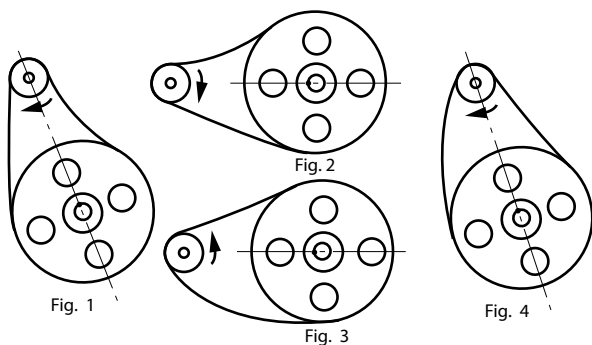

Other Acceptable Arrangements

If none of the above arrangements can be followed, an attempt should be made to use an arrangement as illustrated in Figs. 5, 6, and 7.

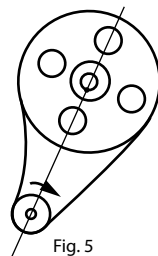

Fig. 5

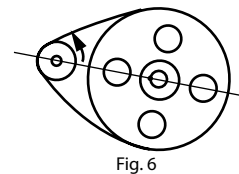

Fig. 6

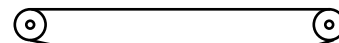

Fig. 7

When the large sprocket is directly above the small sprocket, Fig. 8, a drive cannot operate with much chain slack. As the chain wears, shaft-center distance must be adjusted or an idler be placed against the outside of the slack strand (near the small sprocket) to adjust slack and keep the chain in proper contact with the small sprocket.

With the drive slightly inclined, Fig. 5, less care will be required, because the weight of the slack chain strand helps to maintain better contact between the chain and the sprockets.

Where center distances are short, or drives nearly horizontal, the slack should be in the bottom strand, especially where take-up adjustment is limited, Fig. 6 rather than Fig. 9. An accumulation of slack in the top strand may allow the chain to be pinched between the sprockets, Fig. 9.

When small sprockets are used on horizontal drives, it is better to have the slack strand on the bottom, Fig. 7, rather than on the top, Fig. 10. Otherwise, with the appreciable amount of slack, the strands may strike each other.

Least Recommended Arrangements

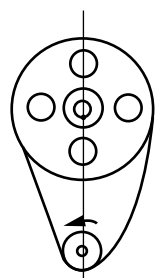

Fig. 8

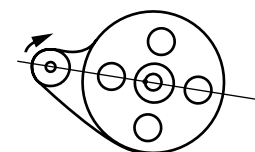

Fig. 9



Fig. 10

Design and Selection

Drive Chain Selection

Selecting a Chain Using Selection Tables

- Step 1.** Determine Horsepower... Motor or actual.
Step 2. Select Service Factor (SF)...
 See Table 1, pages 94-102.
Step 3. Calculate Design Horsepower (DHP).
 $DHP = SF \times HP$.
Step 4. Determine Speed... Driver Shaft RPM.
Step 5. Select the chains in the 12T. column from Table 2, pages 94-102.
 Example: 20 HP; 70 RPM; 1.25 SF: (DHP = HP)

RPM Drive Sprocket	25 DHP						
	Driver Sprocket-No. of Teeth - Hub Size Letter						Hub Letter
	9T	12T	15T				
80-90	1037	3 ³ / ₁₆	1030	5 ¹⁵ / ₁₆	R3112	4 ¹⁵ / ₁₆	I
			3160	3 ³ / ₁₆	3160	4 ⁷ / ₁₆	
70-80	1037	3 ³ / ₁₆	1030	5 ¹⁵ / ₁₆	R3112	5 ¹⁵ / ₁₆	I
			3180	3 ¹¹ / ₁₆	3160	4 ⁷ / ₁₆	
60-70	1037	3 ³ / ₁₆	R1030	5 ¹⁵ / ₁₆	R3112	4 ¹⁵ / ₁₆	J
			3180	3 ¹¹ / ₁₆	3160	4 ⁷ / ₁₆	

Note: If the RPM appears in two rows in the RPM column of the Selection Table (i.e. 70 RPM appears in 60-70 and 70-80 RPM rows) use the faster speed range for greatest economy. Also, see Step 6 for alternate selection.

12-Tooth Sprocket Selection Advantages

1. Most economical "Power Package" of chain and sprockets.
2. Quiet operation.
3. Increased wear life – approximately 70% greater chain wear life than a 9-tooth selection.
4. Best for space available and system economy.
5. Offers large speed ratio possibilities.

Step 6. Choose the proper drive. When an alternative is listed for a given selection (i.e. 3100 Series chain is listed) choose the better drive based on the following considerations:

- a. Cost** – Evaluate the total cost of each drive package: chain and sprockets.
- b. Space Limitations** – The smaller pitch chain (usually 3100 Series) should provide the drive requirements in less space.
- c. Availability** – If delivery is crucial, Contact Rexnord to see which of the two chains is more readily available.
- d. ANSI Replacement** – The 3100 Series chains replace corresponding ANSI roller chains up to 350 RPM. This series chain operates over the same sprockets.
- e. Shaft Size** – The larger pitch chain of the two will probably have to be used when the driver shaft size exceeds the maximum bore listed for the smaller chain.

f. Noise – Smaller pitch chain operating over cut tooth sprockets will provide quieter and smoother operation.

Step 7. For alternates to the 12-Tooth Sprocket Selection, see the 9- or 15-Tooth Sprocket Selections.

Check:

Space – Will sprocket and chain fit in the allowable space? For pitch diameter, see table on page 120. Generally minimum space required for chain and sprocket = 1.2 x Pitch Diameter.

$$\text{Speed Ratio} = \frac{\text{Driver Shaft RPM}}{\text{Driven Shaft RPM}}$$

Availability – Is Driven sprocket available for required speed ratio?

Select a 9T Sprocket where greater speed ratios and minimum space are required. The majority of 9-tooth selections will result in a space advantage.

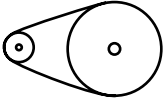
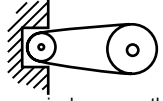
9 - Tooth Sprocket Selection	
Advantages	Limitations
<ol style="list-style-type: none"> 1.  Greater Speed Ratios 2.  Generally, require less space that the 12T sprocket selection 	<ol style="list-style-type: none"> 1. Generally higher cost 2. Greater noise 3. Maximum wear 4. Less smooth running more pulsations. (See Chordal Action Table on next page.)

Select a 15T Sprocket where **long centers** are necessary and space is not a limiting factor, where maximum speed ratios are not required, or where quiet operation is desired.

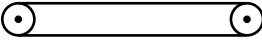
15-Tooth Sprocket Selection	
Advantages	Limitations
 <ol style="list-style-type: none"> 1. Most economical for long centers. 2. Least wear – approximately 150% greater chain wear life than the 9T. 3. Least noise. 	<ol style="list-style-type: none"> 1. More space required. 2. Fewer speed ratio possibilities. 3. More costly than minimum center distances. 4. More chain required in the system.

Design and Selection

Step 8. Determine number of teeth on the Driven sprocket, minimum center distance and chain length.

- Multiply number of teeth on Driver by desired speed ratio (Step 7) to determine number of teeth on Driven sprocket.
- Refer to pages 121-122 for minimum center distance and chain length calculations.

Step 9. Select Driver and Driven Sprocket Hubs and Material.

a. Driver Sprocket and Hub

The sprocket hub size letter in the selection table identifies the minimum "Torque Rated" hub that will transmit the desired horsepower. Refer to the example shown in Step 5 on page 89. For this example, the hub is specified as letter I. The table on page 72 recommends a hub size of 4.5" by 2.0" (for a solid sprocket). The table also identifies the torque being transmitted, in this case up to 23,000 in.-lbs. The hub size and bore diameter listed are recommended based on the limitations of the typical shaft material having a maximum torsion shear stress of 6,000 psi. If the shaft has already been determined, use the bore size column to select the appropriate hub dimensions.

Note: Fabricated steel sprockets with induction hardened teeth are the recommended first choice for drive applications but, if a cast sprocket is desired, be sure to check availability of the cast pattern as listed beginning on page 74. If the sprocket unit number is not listed, a pattern is not available. The table gives stocked hub dimensions. Cast to order sprocket hubs would be sized per page 72.

b. Driven Sprocket and Hub

The proper Driven sprocket hub can be determined from the following:

$$\text{Driven Hub Torque} = \text{Speed Ratio} \times \text{Driver Hub Torque}$$

The speed ratio and driver torque were determined in Step 8b and Step 9a. The Driven sprocket hub is selected based on the driven hub torque and using the tables on page 72. Referring to the example above, the driver hub was size I and the torque transmitted was 23,000 in.-lbs. If the speed ratio were 2 to 1, we would be transmitting 46,000 in.-lbs. and would require a size L hub, (5.25 by 3) or larger.

c. Largest Keyseated Bore

The "Largest Keyseated Bore" next to each chain selection indicates the largest shaft that can be used with the sprocket, sprocket material, and hub size letter selected.

Step 10.

Use the recommended lubrication method as shown in Table 2, pages 94-102. For the recommended lubricant, see page 116.

Note: For example of selection, see page 91.

Chordal Action

The rise and fall of each pitch of chain as it engages a sprocket is termed "chordal action" and causes repeated chain speed variations (pulsations). As illustrated by the chart below, chordal action and speed variation decreases as the number of teeth in the small sprocket is increased, and becomes negligible when 21 or more teeth are used. For example, the variation between minimum and maximum chain speed due to chordal action is 13% for a 6-tooth sprocket, 4% for an 11-tooth sprocket, and 1% for a 21-tooth sprocket. Where smooth operation is essential, use as many teeth as possible in the small sprocket.

Variation in Chain Speed Due to Chordal Action

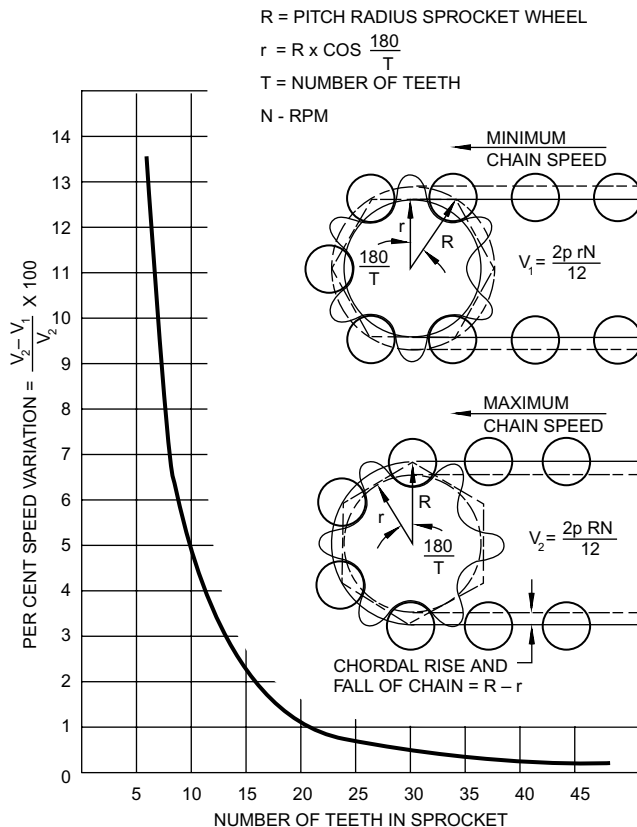

Design and Selection

Drive Chain Selection

Selecting a Chain Using Selection Tables

Drive Chain Selection Example:

A single roll rock crusher is to be operated at 44 RPM driven by a 50 HP engine. The speed reducer has an output shaft of 3.94", operating at 90 RPM. The crusher shaft is 5.94". The crusher will operate 8 hours per day. Driver sprocket space restriction is 16".

Step 1. Horsepower

Motor or actual: 50 HP

Step 2. Service Factor

Type of Application: Crusher
Service Factor: (See Table 1 on page 92-93 and "Converted Service Factor" chart on page 92.)
10 HR, Motor drive = 1.75 SF
10 HR, Engine driven = 2.0 SF

Step 3. Design Horsepower

DHP = 50 HP x 2.0 SF = 100 DH

Step 4. Speed and Shaft Size

Speed and diameter of Driver shaft: 90 RPM; 3.94" Speed and diameter of Driven shaft: 44 RPM; 6.94"

Step 5. Drive Chain and Driver Sprocket

A chain is selected for a 12-tooth Driver sprocket at 100 DHP, 90 RPM (see Table 2 on page 94-102 for selection).RX238 Chain; 12-tooth Driver Sprocket

Step 6. Choice of Drives

A choice must be made between two drives when both appear. However, at this rating, there is only one chain available – RX238.

Step 7. Space and Speed Ratio

Check space available for Driver sprocket: Using the pitch diameter table on page 121

a. A 12-tooth sprocket has a pitch diameter equivalent to 3.8637 pitches. The diameter in inches would be 3.8637 x the pitch (3.5" for RX238) = 13.52".

b. The minimum space required = 1.2 x 13.52" = 16.23" which is larger than the space available. Repeat steps 5 and 6 using the 9-tooth column in the selection tables.

c. For a 9-tooth sprocket R0635 would be selected. The minimum space would be 1.2 x 13.16" = 15.79" which meets the space restriction.

Determine Speed Ratio:

$$\text{Ratio} = \frac{\text{Driver Shaft RPM}}{\text{Driven Shaft RPM}} = \frac{90 \text{ RPM}}{44 \text{ RPM}} = 2.05 \text{ to } 1$$

Step 8. Drive Sprocket and Center Distance and Change Length

The nearest ratio to 2.05 to 1 is 2.00, with an 18-tooth Driven sprocket. The minimum center distance is 2.06 feet and 9.38 feet of chain is required.

Determine the minimum center distance per the formula on page 121:

$$\text{Min. CDp} = (18 + 9)/6 + 1 = 5.5 \text{ pitches} \frac{18+9+1}{6} = 55$$

$$\text{Min. CD} = \frac{5.5 \times 4.5}{12} = 2.06 \text{ feet}$$

Determine the approximate chain length per the formula on page 122:

$$LP = 2(5.5) + (18 + 9)/2 + (0.0258 \times (18-9)^2 / 5.5) = 24.9 \text{ pitches}$$

25 pitches is the minimum (rounded up)

$$L = \frac{25 \times 4.5}{12} = 9.38 \text{ feet}$$

Step 9. Drive and Drive Sprocket Material and Hub Selection

For the selection table used in Step 7, the required hub letter is N. Per the table on page 70 an N style hub is rated for 70,000 inch pounds and has a diameter of 6" and a length of 3". The plate thickness is 1.75". The total length through bore is 4.75" (3" + 1.75"). Since the sprocket is to be mounted on a reducer, it is recommended that the hub style is offset hubs, one side flush. This would need to be specified as such on the order. The drive hub will need to handle 140,000 inch pounds since the speed ratio is 2 to 1. Per the table on page 70 a size P hub is required. This hub would be 8.75" in diameter and the length through bore would be 10.50".

Step 10. Lubrication

The type of lubrication for this drive selection, has shown in Selection Table 2 on page 94-102, is oil bath.

Design and Selection

Service Factors

Use the table to find the application or the closest similar application. Note whether the operating time will be up to 10 hours a day or from 10 hours to 24 hours a day. In the column to the right of the application, select the Service Factor. This Service Factor determines the Design Horsepower for use in the Chain Selection Table.

Occasional and Intermittent Service or Engine Driven Applications

The Service Factors listed in Table 1 are for electric motor drives and normal conditions. For multi-cylinder engine driven applications and all applications operating intermittently up to 3 hours per day, use the values shown in the Converted Service Factors table. First, find the Service Factor of the same application operating 10 hours per day in Table 1. Next, in the first column of the chart below, find this same service factor in bold face type. Then, to the right under the desired hours service and prime mover locate the Converted Service Factor. For example, in the segment of Table 1 showing service factors by application on page 93, the Service Factor for a uniformly loaded belt conveyor at 10 hours a day is 1.00. From the chart, for the same application, the following are the service factors for various conditions:

1. Engine driven 10 hours per day; use 1.2 Service Factor.
2. Engine driven 3 hours intermittently; use 1.00 Service Factor.
3. Motor driven 3 hours intermittently; use .80 Service Factor.

Converted Service Factors					
10 Hrs. Per Day		24 Hrs. Per Day		Intermittent 3 Hrs. Per Day	
Motor	Engine	Motor	Engine	Motor	Engine
1.00	1.25	1.25	1.50	.80	1.00
1.25	1.50	1.50	1.75	1.00	1.25
1.75	2.00	2.00	2.25	1.50	1.75

For applications operating less than 3 hours per day and applications driven by single cylinder engines, contact Rexnord for other service factors.

These service factors are based on the assumption that the system is free from serious critical and torsional vibrations and that maximum momentary or starting loads do not exceed 200% of the normal load.

Note: For extremely wet or abrasive environments add 0.25 to the applicable service factor.

Table 1
Service Factors Listed By Industry

AGMA Recommendations. Factors are minimum and normal conditions are assumed.

Application	Service Factor		Application	Service Factor		Application	Service Factor		Application	Service Factor	
	10 Hours	24 Hours		10 Hours	24 Hours		10 Hours	24 Hours		10 Hours	24 Hours
Brewing & Distilling			Lumber Industry			Paper Mills			Rubber Industry		
Bottling Machinery.....	1.00	1.25	Barkes-Hydraulic Mechanical...	1.25	1.50	Agitators (Mixers).....	1.25	1.50	Calender.....	1.25	1.50
Brew Kettles Continuous.....	1.00	1.25	Bumer Conveyor.....	1.25	1.50	Barket Auxiliaries, Hydraulic.....	1.25	1.50	Mixer.....	-	2.00
Can Filling Machinery.....	1.00	1.25	Chain & Drag Saw.....	1.50	1.75	Barker Mechanical.....	1.25	1.50	Mill (2 or more).....	-	1.50
Cookers Continuous.....	1.00	1.25	Chain & Craneway Transfer.....	1.50	1.75	Barking Drum.....	1.75	2.00	Sheeter.....	-	1.50
Mash Tub Continuous.....	1.00	1.25	Debarking Drum.....	1.75	2.00	Beater & Pulper.....	1.25	1.50	Tire Building Machine.....	①	①
Scale Hopper Frequent Star.....	1.25	1.50	Edger & Gang Feed.....	1.25	1.50	Bleacher.....	1.00	1.25	Tire & Tube Press Opener.....	①	①
Clay Working Industry			Green Chain.....	1.50	1.75	Calendars.....	1.25	1.50	Tubers & Strainers.....	-	1.50
Brick Press.....	1.75	2.00	Line Rolls, Log Deck, Log Haul			Calendars, Super.....	1.75	2.00	Sewage Disposal		
Briquette Machine.....	1.75	2.00	(Incline & Well Type).....	1.75	2.00	Converting Machine			Bar Screws.....	1.00	1.25
Clay Working Machinery.....	1.25	1.50	Log Turning Device.....	1.75	2.00	(Except Cutters, Platters).....	1.25	1.50	Chemical Feeders.....	1.00	1.25
Pug Mill.....	1.25	1.50	Main Log Conveyor.....	1.75	2.00	Conveyor.....	1.00	1.25	Collectors.....	1.00	1.25
Distilling (See Brewing)			Off Bearing Rolls.....	1.75	2.00	Couch.....	1.25	1.50	Dewatering Screens.....	1.25	1.50
Dredges			Planer Feed & Floor Chains.....	1.25	2.50	Cutters, Platters.....	1.75	2.00	Grit Collectors.....	1.00	1.25
Cable Reels.....	1.25	1.50	Planer Tilting Hoist.....	1.50	1.50	Cylinder.....	1.25	1.50	Scum Breakers.....	1.25	1.50
Conveyors.....	1.25	1.50	Re-Saw Merry-Go-Round Conv....	1.25	1.50	Dryer.....	1.25	1.50	Slow or Rapid Mixer.....	1.25	1.50
Cutter Head Drives.....	1.75	2.00	Roll Cases, Slab Conveyor.....	1.75	2.00	Felt Stretcher.....	1.25	1.50	Sludge Collectors.....	1.00	1.25
Jig Drives.....	1.75	2.00	Small Waste Conveyor - Belt.....	1.00	1.25	Felt Whipper.....	1.75	2.00	Thickeners.....	1.25	1.50
Maneuvering Winches.....	1.25	1.50	Small Waste Conveyor - Chain.....	1.25	1.50	Jordan.....	1.75	2.00	Vacuum Filters.....	1.25	1.50
Pumps.....	1.25	1.50	Sorting Table.....	1.25	1.50	Log Haul.....	1.75	2.00	Textile Industry		
Screen Drive.....	1.75	2.00	Tipple Hoist Conv. & Drive.....	1.25	1.50	Press.....	1.00	1.25	Batcher, Calendar.....	1.25	1.50
Stackers.....	1.25	1.50	Transfer Conveyor & Rolls.....	1.25	1.50	Pulp Machine.....	1.25	1.50	Card Machine.....	1.25	1.50
Utility Winches.....	1.25	1.50	Tray Drive, Trimmer Feed &			Reel.....	1.25	1.50	Cloth Finishing Machine.....	1.25	1.50
Food Industry			Waste Conveyor.....	1.25	1.50	Stock Chest.....	1.25	1.50	Dry Cans, Dryers.....	1.25	1.50
Beet Slicer.....	1.25	1.50	Oil Industry			Suction Roll.....	1.00	1.25	Dyeing Machinery.....	1.25	1.50
Bottling Machine, Can Filling.....	1.25	1.25	Chiller.....	1.25	1.50	Washer & Thickeners.....	1.25	1.50	Knitting Machine.....	①	①
Cooker.....	1.00	1.25	Oil Well Pumping.....	①	①	Winders.....	1.00	1.25	Loom, Mangle, Napper Pads.....	1.25	1.50
Dough Mixer, Meat Grinder.....	1.25	1.50	Paraffin Filter Pass.....	1.25	1.50				Range Drives.....	①	①
			Rotary Kiln.....	1.25	1.50				Slashers, Soapers.....	1.25	1.50
									Spinners.....	1.25	1.50
									enter Frames, Washers.....	1.25	1.50
									Winders (Except Batchers).....	1.25	1.50







① Contact Rexnord for details.

② Table 1 extracted from AGMA Standard Application Classification for Gearmotors (AGMA 150.02) with the permission of the American Gear Manufacturers Association, One Thomas Circle, Washington 5, D.C.

Design and Selection

Table 2
Drive Chain Selection Tables

Note: Rexnord drive chain selections are displayed in the tables. To interchange Link-Belt and Rexnord chain numbers see page 65.

RPM Driver Sprocket	Design Horsepower (DHP) = HP x SF For (SF) see page 92-93				Type of Lubrication	RPM Driver Sprocket	Design Horsepower (DHP) = HP x SF For (SF) see page 92-93				Type of Lubrication
	Driver Sprocket - No. Of Teeth Largest Keyseat Bore						Driver Sprocket - No. Of Teeth Largest Keyseat Bore				
	9T	12T	15T	Hub Letter ②			9T	12T	15T	Hub Letter ②	
1 DHP											
17 1/2-20	R432 1 15/16 3140 1 11/16	R362 2 11/16	R362 3 11/16	E		4-5	R514 2 15/16 3180 ①	R3112 7/16 3180 3 11/16	R588 5 15/16 3140 3 15/16	H	
15-17 1/2	R432 1 15/16 3140 1 11/16	R362 2 11/16	R362 3 11/16	E		3-4	1030 3 7/16 3180 ①	R3112 3 7/16 3180 3 11/16	R3112 4 15/16 3140 3 15/16	I	
12 1/2-15	R778 3 11/16 3140 1 11/16	R432 2 11/16 3120 2 3/16	R362 3 11/16	E		2-3	1030 4 7/16	1030 5 15/16 3180 3 11/16	R514 5 15/16 3160 4 7/16	K	
10-12 1/2	R778 3 7/16 3160 1 5/16	R778 4 15/16 3120 2 3/16	R432 3 11/16	F		1-2	R1248 5 7/16	R1037 5 7/16	R1033 8 3180 4 15/16	N	
7 1/2-10	R588 3 7/16 3160 1 5/16	R778 4 15/16 3140 2 11/16	R778 4 15/16 3120 3 3/16	F		3/4-1	R1248 5 7/16	R1037 4 15/16	R1037 8 3180 4 15/16	O	
5-7 1/2	R558 3 3/16 3180 2 3/16	R588 4 15/16 3160 3 3/16	R778 5 7/16 3120 3 3/16	G		1/2-3/4	R1248 5 7/16	AX1568 5 7/16	R1037 8	P	
						1/4-1/2	R01306 9	RX238 7	RX238 10	S	
2 DHP											
35-40	R432 1 15/16 3140 1 11/16	R362 2 11/16	R362 3 11/16	E		7 1/2-10	R514 2 15/16 3180 ①	R3112 3 7/16 3140 2 11/16	R3112 4 15/16 3140 3 15/16	H	
30-35	R432 1 15/16 3140 1 11/16	R362 2 11/16	R362 3 11/16	E		5-7 1/2	1030 3 7/16	R514 4 7/16 3160 3 3/16	R3112 4 15/16 3140 3 15/16	J	
25-30	R778 3 11/16 3140 1 11/16	R432 2 11/16	R362 3 11/16	E		4-5	R1037 3 15/16	1030 5 15/16 3180 3 11/16	R514 5 15/16 3160 4 7/16	K	
20-25	R778 3 7/16 3160 1 5/16	R778 4 15/16 3120 2 3/16	R432 3 11/16	F		3-4	R1037 3 15/16	R1037 4 15/16 3180 3 11/16	R1033 8 3180 4 15/16	L	
17 1/2-20	R588 3 7/16 3160 1 5/16	R778 4 15/16 3140 2 3/16	R432 3 11/16	F		2-3	R1248 5 7/16	R1037 5 15/16	R1037 8 3180 4 15/16	N	
15-17 1/2	R588 3 7/16 3160 1 5/16	R778 4 15/16 3140 2 11/16	R778 4 15/16 3120 3 3/16	F		1-2	R1248 5 7/16	RX238 7	AX1568 8 1/2	P	
12 1/2-15	R514 2 7/16 3180 2 3/16	R588 4 15/16 3120 2 3/16	R778 5 7/16 3120 3 3/16	G		3/4-1	RO635 5 7/16	R1248 7 1/2	RX238 10	Q	
10-12 1/2	R514 2 7/16 3180 2 3/16	R3112 3 7/16 3140 2 11/16	R588 5 7/16 3120 3 3/16	G		1/2-3/4	RO1306 9	R1248 9	RX238 10	S	
					1/4-1/2	X1307 10	RX1207 ①	RO635 ①	U		
3 DHP											
45-50	R432 1 15/16 3140 1 11/16	R362 2 11/16	R362 3 11/16	E		10-12 1/2	1030 3 7/16 3180 ①	R514 4 7/16 3160 3 3/16	R3112 4 15/16 3140 3 15/16	I	
40-45	R778 3 11/16 3140 1 11/16	R432 2 11/16	R362 3 11/16	E		7 1/2-10	R1033 3 7/16	1030 5 15/16 3160 3 3/16	R514 5 15/16 3140 3 15/16	J	
35-40	R778 3 11/16 3140 1 11/16	R432 2 11/16	R362 3 11/16	E		5-7 1/2	R1037 3 15/16	R1033 5 15/16 3180 3 11/16	1030 7 1/2 3160 4 7/16	K	
30-35	R778 3 7/16 3160 1 5/16	R778 4 15/16 3120 2 3/16	R432 3 11/16	F		4-5	R1037 3 15/16	R1037 5 7/16 3180 3 11/16	R1037 8 3160 4 7/16	L	
25-30	R588 3 7/16 3160 1 5/16	R778 4 15/16 3140 2 3/16	R432 3 11/16	F		3-4	R1248 5 7/16	AX1568 5 7/16	R1037 8 3180 4 15/16	N	
20-25	R514 2 7/16 3180 2 3/16	R588 4 15/16 3120 2 3/16	R778 5 7/16 3120 3 3/16	G		2-3	R1248 5 7/16	RX238 7	AX1568 8 1/2	O	
17 1/2-20	R514 2 7/16 3180 2 3/16	R588 4 15/16 3120 2 3/16	R778 5 7/16 3120 3 3/16	G		1-2	RX1207 6 1/2	R1248 7 1/2	RX238 10	Q	
15-17 1/2	R514 2 7/16 3180 2 3/16	R3112 3 7/16 3140 2 11/16	R588 5 7/16 3120 3 3/16	G		3/4-1	RO1306 9	RX1245 9	R1248 10	S	
12 1/2-15	R514 2 15/16 3180 ①	R3112 3 7/16 3140 2 11/16	R3112 4 15/16 3140 3 15/16	H		1/2-3/4	X1307 10	RO635 9 1/2	RO635 ①	T	
						1/4-1/2	1	RX1207 ①	RX1207 ①	X	

① Contact Rexnord for details.





② Hub size letter - See page 70.

Notes: 3100 Series chain operates over roller chain cut tooth sprockets. Fabricated steel sprockets are recommended.

Design and Selection

Table 2 (Cont'd)
Drive Chain Selection Tables

Note: Rexnord drive chain selections are displayed in the tables. To interchange Link-Belt and Rexnord chain numbers see page 66.

RPM Driver Sprocket	Design Horsepower (DHP) = HP x SF For (SF) see page 92-93				Type of Lubrication	RPM Driver Sprocket	Design Horsepower (DHP) = HP x SF For (SF) see page 92-93				Type of Lubrication
	Driver Sprocket - No. Of Teeth Largest Keyseat Bore						Driver Sprocket - No. Of Teeth Largest Keyseat Bore				
	9T	12T	15T	Hub Letter ②			9T	12T	15T	Hub Letter ②	
4 DHP											
80-90	R362 1 ¹⁵ / ₁₆ 3120 1 ¹¹ / ₁₆	R362 2 ¹⁵ / ₁₆	R362 3 ¹¹ / ₁₆	D	 Manual	15-17 ¹ / ₂	1030 3 ¹¹ / ₁₆ 3180 ①	R514 4 ⁷ / ₁₆	R3112 4 ¹⁵ / ₁₆ 3140 3 ¹⁵ / ₁₆	H	 Manual
70-80	R432 1 ¹⁵ / ₁₆ 3140 1 ¹¹ / ₁₆	R362 2 ¹¹ / ₁₆	R362 3 ¹¹ / ₁₆	E		12 ¹ / ₂ -15	R1035 3 ⁷ / ₁₆	1030 5 ¹⁵ / ₁₆ 3160 3 ³ / ₁₆	R514 5 ¹⁵ / ₁₆ 3140 3 ¹⁵ / ₁₆	I	
60-70	R432 1 ¹⁵ / ₁₆ 3140 1 ¹¹ / ₁₆	R362 2 ¹¹ / ₁₆	R362 3 ¹¹ / ₁₆	E		10-12 ¹ / ₂	R1037 3 ¹⁵ / ₁₆	R1033 5 ¹⁵ / ₁₆ 3160 3 ³ / ₁₆	1030 7 3160 4 ⁷ / ₁₆	J	
50-60	R778 3 ¹¹ / ₁₆ 3140 1 ¹¹ / ₁₆	R432 1 ¹¹ / ₁₆	R362 3 ¹¹ / ₁₆	E		7 ¹ / ₂ - 10	R1037 3 ¹⁵ / ₁₆	R1037 5 ⁷ / ₁₆ 3180 3 ¹¹ / ₁₆	R1033 7 ¹ / ₂ 3160 4 ⁷ / ₁₆	K	
45-50	R778 3 ¹¹ / ₁₆ 3140 1 ¹¹ / ₁₆	R432 2 ¹¹ / ₁₆ 3120 2 ³ / ₁₆	R362 3 ¹¹ / ₁₆	E		5 - 7 ¹ / ₂	R1037 3 ¹⁵ / ₁₆	R1037 5 ⁷ / ₁₆ 3180 3 ¹¹ / ₁₆	R1037 8 3160 4 ⁷ / ₁₆	M	
40-45	R778 3 ⁷ / ₁₆ 3160 1 ¹⁵ / ₁₆	R778 4 ¹⁵ / ₁₆ 3120 2 ³ / ₁₆	R432 3 ¹¹ / ₁₆	F		4 - 5	R1248 5 ⁷ / ₁₆	AX1568 5 ⁷ / ₁₆	R1037 8 3180 4 ¹⁵ / ₁₆	N	
35-40	R778 3 ⁷ / ₁₆ 3160 1 ¹⁵ / ₁₆	R778 4 ¹⁵ / ₁₆ 3120 2 ³ / ₁₆	R432 3 ¹¹ / ₁₆ 3120 3 ³ / ₁₆	F		3-4	R1248 5 ⁷ / ₁₆	RX238 7	AX156 8 ¹ / ₂ 3180 4 ¹⁵ / ₁₆	O	
30-35	R588 3 ⁷ / ₁₆ 3160 1 ¹⁵ / ₁₆	R778 4 ¹⁵ / ₁₆ 3120 2 ³ / ₁₆	R778 4 ¹⁵ / ₁₆ 3120 3 ³ / ₁₆	F		2-3	R1248 5 ⁷ / ₁₆	RX238 7	RX238 10	P	
25-30	R514 2 ⁷ / ₁₆ 3180 2 ³ / ₁₆	R588 4 ¹⁵ / ₁₆ 3140 2 ¹¹ / ₁₆	R778 5 ⁷ / ₁₆ 3120 3 ³ / ₁₆	G		1-2	RO1306 9	RX1248 9	R1248 10	S	
20-25	R514 2 ⁷ / ₁₆ 3180 2 ³ / ₁₆	R3112 3 ⁷ / ₁₆ 3140 2 ¹¹ / ₁₆	R588 5 ⁷ / ₁₆ 3120 3 ³ / ₁₆	G		3/4 - 1	RO1306 9	RX1207 ①	RO635 ①	T	
17 ¹ / ₂ -20	R514 2 ¹⁵ / ₁₆ 3180 ①	R3112 3 ⁷ / ₁₆ 3140 2 ¹¹ / ₁₆	R588 5 ¹⁵ / ₁₆ 3140 3 ¹⁵ / ₁₆	H	1/2 - 3/4	X1307 10	RX1207 ①	R0365 ①	U		
					1/4 - 1/2	-	RO1306 ①	RX1207 ①	G		
5 DHP											
100-125	R362 1 ¹⁵ / ₁₆ 3120 1 ¹¹ / ₁₆	R362 2 ¹⁵ / ₁₆	R362 3 ¹¹ / ₁₆	D	 Flow	17 ¹ / ₂ -20	1030 3 ⁷ / ₁₆ 3180 ①	R514 4 ⁷ / ₁₆ 3160 3 ³ / ₁₆	R3112 4 ¹⁵ / ₁₆ 3140 3 ¹⁵ / ₁₆	I	 Manual
90-100	R432 1 ¹⁵ / ₁₆ 3120 1 ¹¹ / ₁₆	R362 2 ¹⁵ / ₁₆	R362 3 ¹¹ / ₁₆	D		15-17 ¹ / ₂	R1037 3 ³ / ₁₆	1030 5 ¹⁵ / ₁₆ 3160 3 ³ / ₁₆	R514 5 ¹⁵ / ₁₆ 3160 4 ⁷ / ₁₆	I	
80-90	R432 1 ¹⁵ / ₁₆ 3120 1 ¹¹ / ₁₆	R362 2 ¹¹ / ₁₆	R362 3 ¹¹ / ₁₆	E		12 ¹ / ₂ - 15	R1037 3 ¹⁵ / ₁₆	R1033 5 ¹⁵ / ₁₆ 3160 3 ³ / ₁₆	1030 7 3160 4 ⁷ / ₁₆	J	
70-80	R432 1 ¹⁵ / ₁₆ 3140 1 ¹¹ / ₁₆	R362 2 ¹¹ / ₁₆	R362 3 ¹¹ / ₁₆	E		10 - 12 ¹ / ₂	R1037 3 ¹⁵ / ₁₆	R1035 5 ⁷ / ₁₆ 3180 3 ¹¹ / ₁₆	R1033 7 ¹ / ₂ 3160 4 ⁷ / ₁₆	K	
60-70	R778 3 ¹¹ / ₁₆ 3140 1 ¹¹ / ₁₆	R432 2 ¹¹ / ₁₆	R362 3 ¹¹ / ₁₆	E		7 ¹ / ₂ - 10	AX1568 3 ¹¹ / ₁₆	R1037 5 ⁷ / ₁₆ 3180 3 ¹¹ / ₁₆	R1037 8 3180 4 ¹⁵ / ₁₆	L	
50-60	R778 3 ⁷ / ₁₆ 3160 1 ¹⁵ / ₁₆	R778 4 ¹⁵ / ₁₆ 3120 2 ³ / ₁₆	R432 3 ¹¹ / ₁₆	F		5 - 7 ¹ / ₂	R1248 5 ⁷ / ₁₆	AX1568 5 ⁷ / ₁₆	R1037 8 3180 4 ¹⁵ / ₁₆	N	
45-50	R588 3 ⁷ / ₁₆ 3160 1 ¹⁵ / ₁₆	R778 4 ¹⁵ / ₁₆ 3120 2 ³ / ₁₆	R432 3 ¹¹ / ₁₆	F		4 - 5	R1248 5 ⁷ / ₁₆	RX238 7	AX1568 8 ¹ / ₂	O	
40-45	R588 3 ⁷ / ₁₆ 3160 1 ¹⁵ / ₁₆	R778 4 ¹⁵ / ₁₆ 3120 2 ³ / ₁₆	R778 4 ¹⁵ / ₁₆ 3120 3 ³ / ₁₆	F		3 - 4	R1248 5 ⁷ / ₁₆	RX238 7	RX238 10	P	
35-40	R514 2 ⁷ / ₁₆ 3180 2 ³ / ₁₆	R588 4 ¹⁵ / ₁₆ 3140 2 ¹¹ / ₁₆	R778 5 ⁷ / ₁₆ 3120 3 ³ / ₁₆	G		2 - 3	RO635 5 ⁷ / ₁₆	R1248 7 ¹ / ₂	RX238 10	Q	
30-35	R514 2 ⁷ / ₁₆ 3180 2 ³ / ₁₆	R588 4 ¹⁵ / ₁₆ 3140 1 ¹¹ / ₁₆	R778 5 ⁷ / ₁₆ 3120 3 ³ / ₁₆	G		1 - 2	RO136 9	RO635 9 ¹ / ₂	RX1245 10	S	
25-30	R515 2 ⁷ / ₁₆ 3180 2 ³ / ₁₆	R3112 3 ⁷ / ₁₆ 3140 2 ¹¹ / ₁₆	R588 5 ⁷ / ₁₆ 3140 3 ¹⁵ / ₁₆	G	3/4 - 1	X1307 10	RX1207 ①	RO635 ①	U		
20-25	R514 2 ¹⁵ / ₁₆ 3180 ①	R3112 3 ⁷ / ₁₆ 3160 3 ³ / ₁₆	R3112 4 ¹⁵ / ₁₆ 3140 3 ¹⁵ / ₁₆	H	1/2 - 3/4	X1307 9 ¹ / ₂	RX1207 ①	RX1207 ①	W		
					1/4 - 1/2	1	RO1306 ①	RO1306 ①	Z		

① Contact Rexnord for details.





② Hub size letter - See page 70.

Notes: 3100 Series chain operates over roller chain cut tooth sprockets. Fabricated steel sprockets are recommended.

Design and Selection

Table 2 (Cont'd)
Drive Chain Selection Tables

Note: Rexnord drive chain selections are displayed in the tables. To interchange Link-Belt and Rexnord chain numbers see page 65.







RPM Driver Sprocket	Design Horsepower (DHP) = HP x SF For (SF) see page 92-93				Type of Lubrication	RPM Driver Sprocket	Design Horsepower (DHP) = HP x SF For (SF) see page 92-93				Type of Lubrication
	Driver Sprocket - No. Of Teeth Largest Keyseat Bore						Driver Sprocket - No. Of Teeth Largest Keyseat Bore				
	9T	12T	15T	Hub Letter ②			9T	12T	15T	Hub Letter ②	
7 1/2 DHP											
300 -350	R362 1 ¹⁵ / ₁₆ 3120 1 ⁷ / ₁₆	R362 2 ¹⁵ / ₁₆	R362 3 ¹¹ / ₁₆	C	 Oil Bath	35 - 40	R514 2 ¹⁵ / ₁₆ 3180 ①	53112 3 ⁷ / ₁₆ 3160 3 ³ / ₁₆	R588 5 ¹⁵ / ₁₆	H	Flow
250-300	R362 1 ¹¹ / ₁₆ 3120 1 ⁷ / ₁₆	R362 2 ¹⁵ / ₁₆	R362 3 ¹¹ / ₁₆	C		30-35	R514 2 ¹⁵ / ₁₆ 3180 ①	R3112 3 ⁷ / ₁₆ 3160 3 ³ / ₁₆	R3112 4 ¹⁵ / ₁₆ 3160 4 ⁷ / ₁₆	H	
200-250	R362 1 ¹⁵ / ₁₆ 3120 1 ⁷ / ₁₆	R362 2 ¹¹ / ₁₆	R362 3 ¹¹ / ₁₆	D		25-30	R1033 3 ¹¹ / ₁₆ 3180 ①	R514 4 ⁷ / ₁₆ 3160 3 ³ / ₁₆	R3112 4 ¹⁵ / ₁₆ 3160 4 ⁷ / ₁₆	I	
175-200	R432 1 ¹⁵ / ₁₆ 3120 1 ⁷ / ₁₆	R362 2 ¹⁵ / ₁₆	R362 3 ¹¹ / ₁₆	D		20-25	R1037 3 ³ / ₁₆	1030 5 ¹⁵ / ₁₆ 3160 3 3/16	R514 5 ¹⁵ / ₁₆ 3160 4 ⁷ / ₁₆	I	
150-175	R432 1 ¹⁵ / ₁₆ 3120 1 ⁷ / ₁₆	R362 2 ¹⁵ / ₁₆	R362 3 ¹¹ / ₁₆	D		17 1/2 - 20	R1037 3 ¹⁵ / ₁₆	R1033 5 ¹⁵ / ₁₆ 3180 3 ¹¹ / ₁₆	1030 7 3160 4 ⁷ / ₁₆	J	
125 - 150	R432 1 ¹⁵ / ₁₆ 3140 1 ¹¹ / ₁₆	R362 2 ¹¹ / ₁₆	R362 3 ¹¹ / ₁₆	E		15 - 17 1/2	R1037 3 ¹⁵ / ₁₆	R1035 5 ⁷ / ₁₆ 3180 3 ¹¹ / ₁₆	R1033 7 ¹ / ₂ 3160 4 ⁷ / ₁₆	K	
100 - 125	R778 3 ¹¹ / ₁₆ 3140 1 ¹¹ / ₁₆	R362 2 ¹¹ / ₁₆ 3120 2 ³ / ₁₆	R362 3 ¹¹ / ₁₆	E		12 1/2 - 15	AX1568 3 ¹¹ / ₁₆	R1037 5 ⁷ / ₁₆ 3180 3 ¹¹ / ₁₆	R1037 7 ¹ / ₂ 3180 4 ¹⁵ / ₁₆	K	 Manual
90 -100	R778 3 ¹¹ / ₁₆ 3140 1 ¹¹ / ₁₆	R432 2 ¹¹ / ₁₆ 3120 2 ³ / ₁₆	R362 3 ¹¹ / ₁₆	E		10 -12 1/2	RX238 4 ⁷ / ₁₆	AX1568 5 ⁷ / ₁₆ 3180 3 ¹¹ / ₁₆	R1037 8 3180 4 ¹⁵ / ₁₆	L	
80 - 90	R778 3 ⁷ / ₁₆ 3160 1 ¹⁵ / ₁₆	R432 2 ⁷ / ₁₆ 3120 2 ³ / ₁₆	R432 3 ¹¹ / ₁₆ 3120 3 ⁷ / ₁₆	F		7 1/2 - 10	RX238 4 ⁷ / ₁₆	RX238 7	AX1568 8 ¹ / ₂ 3180 4 ¹⁵ / ₁₆	N	
70-80	R588 3 ⁷ / ₁₆ 3160 1 ¹⁵ / ₁₆	R778 4 ¹⁵ / ₁₆ 3140 2 ¹¹ / ₁₆	R432 3 ¹¹ / ₁₆ 3120 3 ³ / ₁₆	F		5 -7 1/2	R1248 5 ⁷ / ₁₆	RX238 7	RX238 10	O	
60-70	R588 3 ⁷ / ₁₆ 3160 1 ¹⁵ / ₁₆	R778 4 ¹⁵ / ₁₆ 3140 2 ¹¹ / ₁₆	R778 4 ¹⁵ / ₁₆ 3140 3 ¹⁵ / ₁₆	F	4-5	RX1245 5 ⁷ / ₁₆	RX1248 8	RX238 10	P		
50-60	R588 3 ³ / ₁₆ 3180 2 ³ / ₁₆	R588 4 ¹⁵ / ₁₆ 3140 2 ¹¹ / ₁₆	R778 4 ¹⁵ / ₁₆ 3140 3 ¹⁵ / ₁₆	G	3-4	RO635 5 ⁷ / ₁₆	RX1245 9	R1248 10	Q		
45-50	R514 2 ¹⁵ / ₁₆ 3180 2 ³ / ₁₆	R588 4 ¹⁵ / ₁₆ 3140 2 ¹¹ / ₁₆	R778 5 ⁷ / ₁₆ 3140 3 ¹⁵ / ₁₆	G	2-3	RO1306 9	RO635 9 ¹ / ₂	RX1245 10	R		
40 - 45	R514 2 ¹⁵ / ₁₆ 3180 2 ³ / ₁₆	R588 4 ¹⁵ / ₁₆ 3160 3 ³ / ₁₆	R588 5 ⁷ / ₁₆ 3140 3 ¹⁵ / ₁₆	G	1-2	X1307 10	RX1207 ①	RX1207 ①	U		
					3/4 - 1	X1307 9 ¹ / ₂	RO1306 ①	RX1207 ①	W		
					1/2 - 3/4	1	RO1306 ①	RO1306 ①	Y		
					1/4 - 1/2	1	1	X1307 ①	1		
10 DHP											
300-350	R432 1 ¹⁵ / ₁₆ 3120 1 ⁷ / ₁₆	R362 2 ¹⁵ / ₁₆	R362 3 ¹¹ / ₁₆	D	 Oil Bath	40- 45	1030 3 ¹¹ / ₁₆ 3180 ①	R3112 3 ⁷ / ₁₆ 3160 3 ³ / ₁₆	R3112 4 ¹⁵ / ₁₆ 3160 4 ⁷ / ₁₆	H	 Flow
250-300	R432 1 ¹⁵ / ₁₆ 3120 1 ⁷ / ₁₆	R362 2 ¹⁵ / ₁₆	R362 2 ¹¹ / ₁₆	D		35-40	1030 3 ⁷ / ₁₆ 3180 ①	R514 4 ⁷ / ₁₆ 3160 3 ³ / ₁₆	R3112 4 ¹⁵ / ₁₆ 3160 4 ⁷ / ₁₆	I	
200-250	R432 1 ¹⁵ / ₁₆ 3120 1 ⁷ / ₁₆	R362 2 ¹⁵ / ₁₆	R362 3 ¹¹ / ₁₆	D		30-35	R1035 3 ⁷ / ₁₆	1030 5 ¹⁵ / ₁₆ 3160 3 ³ / ₁₆	R514 5 ¹⁵ / ₁₆ 3160 4 ⁷ / ₁₆	I	
175-200	R432 1 ¹⁵ / ₁₆ 3140 1 ¹¹ / ₁₆	R362 2 ¹¹ / ₁₆	R362 3 ¹¹ / ₁₆	E		25 - 30	R1037 3 ¹⁵ / ₁₆	1030 5 ¹⁵ / ₁₆ 3180 3 ¹¹ / ₁₆	R514 5 ¹⁵ / ₁₆ 3160 4 ⁷ / ₁₆	J	
150-175	R432 1 ¹⁵ / ₁₆ 3140 1 ¹¹ / ₁₆	R362 1 ¹¹ / ₁₆ 3120 2 ³ / ₁₆	R362 3 ¹¹ / ₁₆	E		20 - 25	R1037 3 ¹⁵ / ₁₆	R1037 5 ⁷ / ₁₆ 3180 3 ¹¹ / ₁₆	1030 7 ¹ / ₂ 3160 4 ⁷ / ₁₆	K	
125-150	R432 2 ¹¹ / ₁₆ 3140 1 ¹¹ / ₁₆	R432 2 ¹¹ / ₁₆ 3120 2 ³ / ₁₆	R362 3 ¹¹ / ₁₆ 3120 3 ³ / ₁₆	E		17 1/2 - 20	AX1568 3 ¹¹ / ₁₆	R1037 5 ⁷ / ₁₆ 3180 3 ¹¹ / ₁₆	R1035 7 ¹ / ₂ 3180 4 ¹⁵ / ₁₆	K	
100 - 125	R588 3 ⁷ / ₁₆ 3160 1 ¹⁵ / ₁₆	R778 4 ¹⁵ / ₁₆ 3140 2 ¹¹ / ₁₆	R432 3 ¹¹ / ₁₆ 3120 3 ³ / ₁₆	F		15 - 17 1/2	RX238 4 ⁷ / ₁₆	R1037 5 ⁷ / ₁₆ 3180 3 ¹¹ / ₁₆	R1037 8 3180 4 ¹⁵ / ₁₆	L	 Manual
90-100	R588 3 ⁷ / ₁₆ 3160 1 ¹⁵ / ₁₆	R778 4 ¹⁵ / ₁₆ 3140 2 ¹¹ / ₁₆	R432 3 ¹¹ / ₁₆ 3120 3 ³ / ₁₆	F		12 1/2 - 15	RX238 4 ⁷ / ₁₆	AX1568 5 ⁷ / ₁₆	R1037 8 3180 4 ¹⁵ / ₁₆	M	
80 - 90	R588 3 ⁷ / ₁₆ 3160 1 ¹⁵ / ₁₆	R778 4 ¹⁵ / ₁₆ 3140 2 ¹¹ / ₁₆	R778 4 ¹⁵ / ₁₆ 3120 3 ³ / ₁₆	F		10 -12 1/2	RX238 4 ⁷ / ₁₆	RX238 7	AX1568 8 ¹ / ₂	N	
70-80	R514 2 ⁷ / ₁₆ 3180 2 ³ / ₁₆	R588 4 ¹⁵ / ₁₆ 3140 2 ¹¹ / ₁₆	R778 5 ⁷ / ₁₆ 3140 3 ¹⁵ / ₁₆	G		7 1/2 -10	R1248 5 ⁷ / ₁₆	RX238 7	RX238 10	O	
60-70	R514 2 ⁷ / ₁₆ 3180 2 ³ / ₁₆	R588 4 ¹⁵ / ₁₆ 3140 2 ¹¹ / ₁₆	R778 5 ⁷ / ₁₆ 3140 3 ¹⁵ / ₁₆	G	5 - 7 1/2	RX1245 5 ⁷ / ₁₆	R1248 8	RX238 10	P		
50-60	R514 2 ⁷ / ₁₆ 3180 2 ³ / ₁₆	R3112 3 ⁷ / ₁₆ 3160 3 ³ / ₁₆	R588 5 ⁷ / ₁₆ 3140 3 ¹⁵ / ₁₆	G	4 - 5	RO635 5 ⁷ / ₁₆	RO635 9 ¹ / ₂	R1248 10	Q		
45-50	R514 2 ¹⁵ / ₁₆ 3180 ①	R3112 3 ⁷ / ₁₆ 3160 3 ³ / ₁₆	R588 5 ¹⁵ / ₁₆ 3140 3 ¹⁵ / ₁₆	H	3-4	R1207 6 ¹ / ₂	RO635 9 ¹ / ₂	RX1245 10	R		
					2-3	RO1306 9	RX1207 ①	RO635 ①	S		
					1-2	X1307 9 ¹ / ₂	RO1306 ①	RX1207 ①	W		
					3/4 - 1	1	RO1306 ①	RO1306 ①	X		

① Contact Rexnord for details.
② Hub size letter - See page 70.
Notes: 3100 Series chain operates over roller chain cut tooth sprockets.
Fabricated steel sprockets are recommended.

Design and Selection

Table 2 (Cont'd)
Drive Chain Selection Tables

Note: Rexnord drive chain selections are displayed in the tables. To interchange Link-Belt and Rexnord chain numbers see page 65.

RPM Driver Sprocket	Design Horsepower (DHP) = HP x SF For (SF) see page 92-93				Type of Lubrication	RPM Driver Sprocket	Design Horsepower (DHP) = HP x SF For (SF) see page 92-93				Type of Lubrication	
	Driver Sprocket - No. Of Teeth Largest Keyseat Bore						Driver Sprocket - No. Of Teeth Largest Keyseat Bore					
	9T	12T	15T	Hub Letter ②			9T	12T	15T	Hub Letter ②		
15 DHP												
300-350	R432 1 ¹⁵ / ₁₆ 3140 1 ¹¹ / ₁₆	R432 2 ¹⁵ / ₁₆	R362 3 ¹¹ / ₁₆	D	 Oil Bath	40-45	R1037 3 ¹⁵ / ₁₆	1030 5 ¹⁵ / ₁₆ 3160 3 ³ / ₁₆	R514 5 ¹⁵ / ₁₆ 3160 4 ⁷ / ₁₆	J	 Flow	
250 -300	R432 1 ¹⁵ / ₁₆ 3140 1 ¹¹ / ₁₆	R432 2 ¹¹ / ₁₆	R632 3 ¹¹ / ₁₆	E		35-40	R1037 3 ¹⁵ / ₁₆	R1033 5 ¹⁵ / ₁₆ 3180 3 ¹¹ / ₁₆	1030 7 3160 4 ⁷ / ₁₆	J		
200-250	R778 3 ¹¹ / ₁₆ 3140 1 ¹⁵ / ₁₆	R432 2 ¹⁵ / ₁₆ 3120 2 ⁹ / ₁₆	R632 3 ¹¹ / ₁₆	E		30-35	R1037 3 ¹⁵ / ₁₆	R1037 5 ⁷ / ₁₆ 3180 3 ¹¹ / ₁₆	R1003 7 ¹ / ₂ 3160 4 ⁷ / ₁₆	K		
175-200	R588 3 ¹¹ / ₁₆ 3160 1 ¹⁵ / ₁₆	R432 2 ¹¹ / ₁₆ 3120 2 ⁹ / ₁₆	R632 3 ¹¹ / ₁₆	E		25-30	AX1568 3 ¹¹ / ₁₆	R1037 5 ⁷ / ₁₆ 3180 3 ¹¹ / ₁₆	R1037 7 ¹ / ₂ 3180 4 ¹⁵ / ₁₆	K		
150-175	R588 3 ¹¹ / ₁₆ 3160 1 ¹⁵ / ₁₆	R778 4 ¹⁵ / ₁₆ 3120 2 ⁹ / ₁₆	R432 3 ¹¹ / ₁₆ 3120 3 ⁹ / ₁₆	F		20-25	RX238 4 ⁷ / ₁₆	AX1568 5 ⁷ / ₁₆	R1037 8 3180 4 ¹⁵ / ₁₆	L		
125 - 150	R3112 2 ⁹ / ₁₆ 3160 1 ¹⁵ / ₁₆	R778 4 ¹⁵ / ₁₆ 3120 2 ⁹ / ₁₆	R432 3 ¹¹ / ₁₆ 3120 3 ⁹ / ₁₆	F		17 1/2 - 20	RX238 4 ⁷ / ₁₆	RX238 7	R1037 8	M		
100 - 125	R514 2 ⁷ / ₁₆ 3160 2 ⁹ / ₁₆	R588 4 ¹⁵ / ₁₆ 3140 2 ¹¹ / ₁₆	R778 5 ⁷ / ₁₆ 3120 3 ⁹ / ₁₆	G		15- 17 1/2	R1248 4 ⁷ / ₁₆	RX238 7	AX1568 8 ¹ / ₂	N		
90-100	R514 2 ⁷ / ₁₆ 3180 2 ⁹ / ₁₆	R588 4 ¹⁵ / ₁₆ 3140 2 ¹¹ / ₁₆	R778 5 ⁷ / ₁₆ 3140 3 ¹⁵ / ₁₆	G		 Manual	12 1/2 - 15	R1248 5 ⁷ / ₁₆	RX238 7	RX238 10	O	
80-90	R514 2 ⁷ / ₁₆ 3180 2 ⁹ / ₁₆	R3112 3 ⁷ / ₁₆ 3140 2 ¹¹ / ₁₆	R588 5 ⁷ / ₁₆ 3140 3 ¹⁵ / ₁₆	G			10 - 12 1/2	RX1245 5 ⁷ / ₁₆	R1248 8	RX238 10	O	
70-80	R514 2 ¹⁵ / ₁₆ 3180 ①	R3112 3 ⁷ / ₁₆ 3140 2 ¹¹ / ₁₆	R588 5 ¹⁵ / ₁₆ 3140 3 ¹⁵ / ₁₆	H			7 1/2 - 10	RO635 5 ⁷ / ₁₆	RX1245 8	R1248 10	P	
60-70	1030 3 ¹¹ / ₁₆ 3180 ①	R3112 3 ⁷ / ₁₆ 3160 3 ⁷ / ₁₆	R3112 4 ¹⁵ / ₁₆ 3140 3 ¹⁵ / ₁₆	H			5 - 7 1/2	RX1207 6 ¹ / ₂	RO635 9 ¹ / ₂	RX1245 10	Q	
50-60	R1033 3 ¹¹ / ₁₆	R514 4 ⁷ / ₁₆ 3160 3 ⁹ / ₁₆	R3112 4 ¹⁵ / ₁₆ 3160 4 ⁷ / ₁₆	I			4 - 5	RO1306 9	RO635 9 ¹ / ₂	RO635 ①	R	
45-50	R1037 3 ⁹ / ₁₆	1030 5 ¹⁵ / ₁₆ 3160 3 ⁹ / ₁₆	R514 5 ¹⁵ / ₁₆ 3160 4 ⁷ / ₁₆	I			3 - 4	X1307 10	RO1306 ①	RO635 ①	S	
							2 - 3	X1307 10	RO1306 ①	RX1207 ①	U	
							1 - 2	1	RO1306 ①	RO1306 ①	Y	
					3/4 - 1		1	RO1306 ①	RO1306 ①	Z		
					1/2-3/4		1	1	X1307 ①	1		
20 DHP												
300- 350	R514 2 ¹⁵ / ₁₆ 3160 1 ¹⁵ / ₁₆	R432 2 ¹⁵ / ₁₆ 3120 2 ⁹ / ₁₆	R432 3 ¹¹ / ₁₆	E	 Oil Bath		45-50	R1037 3 ¹⁵ / ₁₆	R035 5 ⁷ / ₁₆ 3180 3 ¹¹ / ₁₆	1030 7 3160 4 ⁷ / ₁₆	J	 Flow
250-300	R514 2 ¹⁵ / ₁₆ 3160 1 ¹⁵ / ₁₆	R432 2 ¹¹ / ₁₆ 3120 2 ⁹ / ₁₆	R432 3 ¹¹ / ₁₆ 3120 3 ⁹ / ₁₆	E			40-45	R1037 3 ¹⁵ / ₁₆	R1037 5 ⁷ / ₁₆ 3180 3 ¹¹ / ₁₆	R1033 7 ¹ / ₂ 3160 4 ¹⁵ / ₁₆	K	
200-250	R514 2 ¹¹ / ₁₆ 3160 1 ¹⁵ / ₁₆	R778 4 ¹⁵ / ₁₆ 3120 2 ⁹ / ₁₆	R432 3 ¹¹ / ₁₆ 3120 3 ⁹ / ₁₆	F			35-40	AX1568 3 ¹¹ / ₁₆	R1037 5 ⁷ / ₁₆ 3180 3 ¹¹ / ₁₆	R1035 7 ¹ / ₂ 3180 4 ¹⁵ / ₁₆	K	
175-200	R514 2 ¹¹ / ₁₆ 3160 1 ¹⁵ / ₁₆	R778 4 ¹⁵ / ₁₆ 3120 2 ⁹ / ₁₆	R432 3 ¹¹ / ₁₆ 3120 3 ⁹ / ₁₆	F			30-35	RX236 4 ⁷ / ₁₆	R1037 5 ⁷ / ₁₆	R1037 8 3180 4 ¹⁵ / ₁₆	L	
150-175	R514 2 ¹¹ / ₁₆ 3180 2 ⁹ / ₁₆	R778 4 ¹⁵ / ₁₆ 3140 2 ¹¹ / ₁₆	R778 4 ¹⁵ / ₁₆ 3120 3 ⁹ / ₁₆	F		25 - 30	RX238 4 ⁷ / ₁₆	AX1568 5 ⁷ / ₁₆	R1037 8	M		
125-150	R514 2 ⁷ / ₁₆ 3180 2 ⁹ / ₁₆	R3112 3 ⁷ / ₁₆ 3140 1 ¹¹ / ₁₆	R778 5 ⁷ / ₁₆ 3140 3 ¹⁵ / ₁₆	G		20-25	81248 4 ⁷ / ₁₆	RX238 7	AX1568 8 ¹ / ₂	N		
100 - 125	R514 2 ⁷ / ₁₆ 3180 2 ⁹ / ₁₆	R3112 3 ⁷ / ₁₆ 3140 2 ¹¹ / ₁₆	R588 5 ⁷ / ₁₆ 3140 3 ¹⁵ / ₁₆	G		 Manual	17 1/2 - 20	R1248 5 ⁷ / ₁₆	RX238 7	RX238 10	O	
90-100	R514 2 ¹⁵ / ₁₆ 3180 ①	R3112 3 ⁷ / ₁₆ 3160 3 ⁹ / ₁₆	R588 5 ¹⁵ / ₁₆ 3140 3 ¹⁵ / ₁₆	H			15-17 1/2	RX1245 5 ⁷ / ₁₆	R1248 8	RX238 10	O	
80-90	1030 3 ¹¹ / ₁₆	R3112 3 ⁷ / ₁₆ 3160 3 ⁹ / ₁₆	R3112 4 ¹⁵ / ₁₆ 3160 4 ⁷ / ₁₆	H			12 1/2 - 15	RO635 5 ⁷ / ₁₆	R1248 8	RX238 10	O	
70-80	R1033 3 ¹¹ / ₁₆	1030 5 ¹⁵ / ₁₆ 3160 3 ⁹ / ₁₆	R3112 4 ¹⁵ / ₁₆ 3160 4 ⁷ / ₁₆	I			10 - 12 1/2	RO635 5 ⁷ / ₁₆	RX1245 8	RX1248 10	O	
60-70	R1037 3 ⁹ / ₁₆	1030 5 ¹⁵ / ₁₆ 3160 3 ⁹ / ₁₆	R514 5 ¹⁵ / ₁₆ 3160 4 ⁷ / ₁₆	I			7 1/2 - 10	RX1207 6 ¹ / ₂	RO635 9 ¹ / ₂	RO635 ①	Q	
50-60	R1037 3 ¹⁵ / ₁₆	R1033 5 ¹⁵ / ₁₆ 3180 3 ¹¹ / ₁₆	1030 7 3160 4 ⁷ / ₁₆	J			5 - 7 1/2	RO1306 9	RO635 9 ¹ / ₂	RO635 ①	S	
							4 - 5	RO1306 9	RX1207 ①	RX1207 ①	S	
							3 - 4	X1307 10	RO1306 ①	RX1207 ①	U	
							2 - 3	X1307 9 ¹ / ₂	RO1306 ①	RO1306 ①	W	
					1 - 2		1	X1307 ①	RO1307 ①	Z		

① Contact Rexnord for details.





② Hub size letter – See page 70.

Notes: 3100 Series chain operates over roller chain cut tooth sprockets. Fabricated steel sprockets are recommended.

Design and Selection

Table 2 (Cont'd)
Drive Chain Selection Tables

Note: Rexnord drive chain selections are displayed in the tables. To interchange Link-Belt and Rexnord chain numbers see page 65.

RPM Driver Sprocket	Design Horsepower (DHP) = HP x SF For (SF) see page 92-93				Type of Lubrication	RPM Driver Sprocket	Design Horsepower (DHP) = HP x SF For (SF) see page 92-93				Type of Lubrication
	Driver Sprocket - No. Of Teeth Largest Keyseat Bore						Driver Sprocket - No. Of Teeth Largest Keyseat Bore				
	9T	12T	15T	Hub Letter ②			9T	12T	15T	Hub Letter ②	
25 DHP											
300-350	R3112 2 ³ / ₁₆ 3160 1 ¹⁵ / ₁₆	R432 2 ¹¹ / ₁₆ 3120 2 ⁹ / ₁₆	R432 3 ¹¹ / ₁₆	E	 Oil Bath	50-60	R1037 3 ¹⁵ / ₁₆	R1037 5 ⁷ / ₁₆ 3180 3 ¹¹ / ₁₆	R1033 7 ¹ / ₂ 3180 4 ¹⁵ / ₁₆	K	 Flow
250-300	R3112 2 ³ / ₁₆ 3160 1 ¹⁵ / ₁₆	R778 4 ¹⁵ / ₁₆ 3120 2 ⁹ / ₁₆	R432 3 ¹¹ / ₁₆ 3120 3 ⁹ / ₁₆	F		45-50	AX1468 3 ¹¹ / ₁₆	R1037 5 ⁷ / ₁₆ 3180 3 ¹¹ / ₁₆	R1035 7 ¹ / ₂ 3180 4 ¹⁵ / ₁₆	K	
200-250	R3112 2 ³ / ₁₆ 3180 2 ³ / ₁₆	R588 4 ¹⁵ / ₁₆ 3140 2 ¹¹ / ₁₆	R778 4 ¹⁵ / ₁₆ 3120 3 ⁹ / ₁₆	F		40-45	RX238 4 ⁷ / ₁₆	R1037 5 ⁷ / ₁₆	81037 8 3180 4 ¹⁵ / ₁₆	L	
175 -200	R514 2 ⁷ / ₁₆	R3112 3 ⁷ / ₁₆ 3140 2 ¹¹ / ₁₆	R778 5 ⁷ / ₁₆ 3120 3 ⁹ / ₁₆	G		35-40	RX238 4 ⁷ / ₁₆	R1037 5 ⁷ / ₁₆	R1037 8	L	
150 -175	514 2 ⁷ / ₁₆ 3180 2 ⁹ / ₁₆	R3112 3 ⁷ / ₁₆ 3140 2 ¹¹ / ₁₆	R778 5 ⁷ / ₁₆ 3140 3 ¹⁵ / ₁₆	G		30-35	RX238 4 ⁷ / ₁₆	AX1568 5 ⁷ / ₁₆	R1037 8	M	
125 - 150	R514 2 ⁷ / ₁₆ 3180 2 ⁹ / ₁₆	R3112 3 ⁷ / ₁₆ 3160 3 ⁹ / ₁₆	R588 5 ⁷ / ₁₆ 3140 3 ¹⁵ / ₁₆	G		25-30	R1248 4 ⁷ / ₁₆	RX238 7	AX1568 8 ¹ / ₂	N	
100-125	1030 3 ¹¹ / ₁₆	R3112 3 ⁷ / ₁₆ 3160 3 ⁹ / ₁₆	R3112 3 ⁷ / ₁₆ 3140 3 ¹⁵ / ₁₆	H		20-25	RX1245 5 ⁷ / ₁₆	RX238 7	RX238 10	O	
90-100	R1030 3 ¹⁵ / ₁₆	R514 4 ⁷ / ₁₆ 3160 3 ⁹ / ₁₆	R3112 4 ¹⁵ / ₁₆ 3160 4 ⁷ / ₁₆	I		17 ¹ / ₂ - 20	RO635 5 ⁷ / ₁₆	R1248 8	RX238 10	O	
80-90	R1037 3 ⁹ / ₁₆	1030 5 ¹⁵ / ₁₆ 3160 3 ⁹ / ₁₆	R3112 4 ¹⁵ / ₁₆ 3160 4 ⁷ / ₁₆	I		15 - 17 ¹ / ₂	RO635 5 ⁷ / ₁₆	R1248 8	RX238 10	P	
70-80	R1037 3 ⁹ / ₁₆	1030 5 ¹⁵ / ₁₆ 3180 3 ¹¹ / ₁₆	R514 5 ¹⁵ / ₁₆ 3160 4 ⁷ / ₁₆	I		12 ¹ / ₂ -15	RO635 5 ⁷ / ₁₆	RO635 9 ¹ / ₂	R1248 10	P	
6070	R1037 3 ¹⁵ / ₁₆	R1033 5 ¹⁵ / ₁₆ 3180 3 ¹¹ / ₁₆	1030 7 3160 4 ⁷ / ₁₆	J	10-12 ¹ / ₂	RX1207 6 ¹ / ₂	RO635 9 ¹ / ₂	RO635 ①	Q		
					7 ¹ / ₂ - 10	RX1207 6 ¹ / ₂	RO635 9 ¹ / ₂	RO635 ①	R		
					5 - 7 ¹ / ₂	RO1306 9	RX1207 ①	RX1207 ①	S		
					4-5	X1307 10	RO1306 ①	RX1207 ①	T		
					3-4	X1307 9 ¹ / ₂	RO1306 ①	RO1306 ①	V		
					2-3	1	X1037 ①	RO1306 ①	X		
30 DHP											
300-350	R3112 2 ³ / ₁₆ 3180 2 ⁹ / ₁₆	R3112 3 ⁷ / ₁₆ 3140 2 ¹¹ / ₁₆	R432 3 ¹¹ / ₁₆ 3120 3 ⁹ / ₁₆	F	 Oil Bath	50-60	AX1568 3 ¹¹ / ₁₆	R1037 5 ⁷ / ₁₆	R1037 7 ¹ / ₂ 3180 4 ¹⁵ / ₁₆	K	 Flow
250-300	R3112 2 ³ / ₁₆ 3180 2 ⁹ / ₁₆	R3112 3 ⁷ / ₁₆ 3140 2 ¹¹ / ₁₆	R432 3 ¹¹ / ₁₆ 3120 3 ⁹ / ₁₆	F		45-50	RX238 4 ⁷ / ₁₆	R1037 5 ⁷ / ₁₆	R1037 8 3180 4 ¹⁵ / ₁₆	L	
200-250	R514 2 ⁷ / ₁₆ 3180 2 ⁹ / ₁₆	R3112 3 ⁷ / ₁₆ 3160 3 ⁹ / ₁₆	R788 5 ⁷ / ₁₆ 3140 3 ¹⁵ / ₁₆	G		40-45	RX238 4 ⁷ / ₁₆	AX1568 5 ⁷ / ₁₆	R1037 8	L	
175-200	R514 2 ⁷ / ₁₆ 3180 2 ⁹ / ₁₆	R3112 3 ⁷ / ₁₆ 3160 3 ⁹ / ₁₆	R588 5 ⁷ / ₁₆ 3140 3 ¹⁵ / ₁₆	G		35-40	RX238 4 ⁷ / ₁₆	RX238 7	R1037 8	M	
150-175	R514 2 ⁷ / ₁₆	R3112 3 ⁷ / ₁₆ 3160 3 ⁹ / ₁₆	R588 5 ⁷ / ₁₆ 3140 3 ¹⁵ / ₁₆	G		30-35	R1248 4 ⁷ / ₁₆	RX238 7	AX1568 8 ¹ / ₂	N	
125-150	1030 3 ¹¹ / ₁₆	R3112 3 ⁷ / ₁₆ 3160 3 ⁹ / ₁₆	R3112 4 ¹⁵ / ₁₆ 3140 3 ¹⁵ / ₁₆	H		25-30	R1248 5 ⁷ / ₁₆	RX238 7	RX238 10	O	
100-125	R1035 3 ⁷ / ₁₆	1030 5 ¹⁵ / ₁₆ 3160 3 ⁹ / ₁₆	R3112 4 ¹⁵ / ₁₆ 3160 4 ⁷ / ₁₆	I		20-25	RO635 5 ⁷ / ₁₆	R1248 8	RX238 10	O	
90-100	R1037 3 ⁹ / ₁₆	1030 5 ¹⁵ / ₁₆ 3180 3 ¹¹ / ₁₆	R514 5 ¹⁵ / ₁₆ 3160 4 ⁷ / ₁₆	I		17 ¹ / ₂ - 20	RO635 5 ⁷ / ₁₆	RX1245 8	R1248 10	P	
80-90	R1037 3 ¹⁵ / ₁₆	1030 5 ¹⁵ / ₁₆ 3180 3 ¹¹ / ₁₆	1030 7 3160 4 ⁷ / ₁₆	J		15-17 ¹ / ₂	RO635 5 ⁷ / ₁₆	RO635 9 ¹ / ₂	R1248 10	P	
70-80	R1037 3 ¹⁵ / ₁₆	R1035 5 ⁷ / ₁₆ 3180 3 ¹¹ / ₁₆	1030 7 3160 4 ⁷ / ₁₆	J		12 ¹ / ₂ -15	RX1207 6 ¹ / ₂	RO635 9 ¹ / ₂	RX1245 10	Q	
60-70	R1037 3 ¹⁵ / ₁₆	R1037 5 ⁷ / ₁₆ 3180 3 ¹¹ / ₁₆	R1033 7 ¹ / ₂ 3180 4 ¹⁵ / ₁₆	K	10-12 ¹ / ₂	RX1207 6 ¹ / ₂	RO635 9 ¹ / ₂	RO635 ①	Q		
					7 ¹ / ₂ - 10	RO1306 9	RO1207 ①	RO635 ①	S		
					5 - 7 ¹ / ₂	X1307 10	RO1306 ①	RX1207 ①	T		
					4-5	X1307 10	RO1306 ①	RO1306 ①	U		
					3-4	X1307 9 ¹ / ₂	RO1306 ①	RX1306 ①	W		
					2-3	1	X1307 ①	RO1306 ①	Y		

① Contact Rexnord for details.





② Hub size letter – See page 70.

Notes: 3100 Series chain operates over roller chain cut tooth sprockets. Fabricated steel sprockets are recommended.

Design and Selection

Table 2 (Cont'd)
Drive Chain Selection Tables

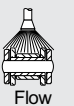
Note: Rexnord drive chain selections are displayed in the tables. To interchange Link-Belt and Rexnord chain numbers see page 66.

RPM Driver Sprocket	Design Horsepower (DHP) = HP x SF For (SF) see page 92-93				Type of Lubrication	RPM Driver Sprocket	Design Horsepower (DHP) = HP x SF For (SF) see page 92-93				Type of Lubrication
	Driver Sprocket - No. Of Teeth Largest Keyseat Bore						Driver Sprocket - No. Of Teeth Largest Keyseat Bore				
	9T	12T	15T	Hub Letter ②			9T	12T	15T	Hub Letter ②	
35 DHP											
300-350	R514 2 ¹¹ / ₁₆ 3180 2 ³ / ₁₆	R3112 3 ⁷ / ₁₆ 3140 2 ¹¹ / ₁₆	R432 3 ¹¹ / ₁₆ 3120 3 ³ / ₁₆	F	 Oil Bath	50-60	RX238 4 ⁷ / ₁₆	R1037 5 ⁷ / ₁₆	R1037 8 3180 4 ¹⁵ / ₁₆	L	 Manual
250-300	R514 2 ⁷ / ₁₆ 3180 2 ³ / ₁₆	R3112 3 ⁷ / ₁₆ 3160 3 ³ / ₁₆	R3112 4 ¹⁵ / ₁₆ 3140 3 ¹⁵ / ₁₆	G		45-50	RX238 4 ⁷ / ₁₆	AX1568 5 ⁷ / ₁₆	R1037 8	M	
200-250	R514 2 ⁷ / ₁₆ 3180 2 ³ / ₁₆	R3112 3 ⁷ / ₁₆ 3160 3 ³ / ₁₆	R3112 4 ⁵ / ₁₆ 3140 3 ¹⁵ / ₁₆	G		40-45	RX238 4 ⁷ / ₁₆	RX238 7	R1037 8	M	
175-200	R514 2 ⁷ / ₁₆	R3112 3 ⁷ / ₁₆ 3160 3 ³ / ₁₆	R3112 4 ¹⁵ / ₁₆ 3140 3 ¹⁵ / ₁₆	G		35-40	R1248 4 ⁷ / ₁₆	RX238 7	AX1568 8 ¹ / ₂	N	
150-175	1030 3 ¹¹ / ₁₆	R3112 3 ⁷ / ₁₆ 3160 3 ³ / ₁₆	R3112 4 ¹⁵ / ₁₆ 3140 3 ¹⁵ / ₁₆	H		30-35	R1248 5 ⁷ / ₁₆	RX238 7	RX238 10	O	
125-150	R1037 3 ³ / ₁₆	1030 5 ¹⁵ / ₁₆ 3180 3 ¹¹ / ₁₆	R3112 4 ¹⁵ / ₁₆ 3160 4 ⁷ / ₁₆	I		25-30	RX1245 5 ⁷ / ₁₆	R1248 8	RX1248 10	O	
100-125	R1037 3 ³ / ₁₆	1030 5 ¹⁵ / ₁₆ 3180 3 ¹¹ / ₁₆	R514 5 ¹⁵ / ₁₆ 3160 4 ⁷ / ₁₆	I		20-25	RO635 5 ⁷ / ₁₆	R1248 8	R1248 10	P	
90-100	R1037 3 ¹⁵ / ₁₆	R1033 5 ¹⁵ / ₁₆ 3180 3 ¹¹ / ₁₆	1030 7 3160 4 ⁷ / ₁₆	J		17 ¹ / ₂ - 20	RO635 5 ⁷ / ₁₆	RO635 9 ¹ / ₂	R1248 10	P	
80-90	R1037 3 ¹⁵ / ₁₆	R1035 5 ⁷ / ₁₆ 3180 3 ¹¹ / ₁₆	1030 7 3160 4 ⁷ / ₁₆	J		15-17 ¹ / ₂	RX1207 6 ¹ / ₂	RO635 9 ¹ / ₂	RO635 ①	Q	
70-80	R1037 3 ¹⁵ / ₁₆	R1037 5 ⁷ / ₁₆ 3180 3 ¹¹ / ₁₆	R1033 7 ¹ / ₂ 3180 4 ¹⁵ / ₁₆	K		12 ¹ / ₂ - 15	RX1207 6 ¹ / ₂	RO635 9 ¹ / ₂	RO635 ①	Q	
60-70	RX238 4 ⁷ / ₁₆	R1037 5 ⁷ / ₁₆	R1035 7 ¹ / ₂ 3180 4 ¹⁵ / ₁₆	K		10-12 ¹ / ₂	RO1306 9	RX1207 ①	RO635 ①	R	
						7 ¹ / ₂ - 10	RO1306 9	RX1207 ①	RX1207 ①	S	
					5 - 7 ¹ / ₂	X1307 10	RO635 ①	RO1306 ①	U		
					4-5	X1307 9 ¹ / ₂	RO1306 ①	RO1306 ①	V		
					3-4	1	RO1306 ①	RO1306 ①	X		
					2-3	1	1	X1307 ①	Z		
40DHP											
300-350	R514 2 ¹¹ / ₁₆ 3180 2 ³ / ₁₆	R3112 3 ⁷ / ₁₆ 3140 2 ¹¹ / ₁₆	R3112 4 ¹⁵ / ₁₆ 3120 3 ³ / ₁₆	F	 Oil Bath	60-70	RX238 4 ⁷ / ₁₆	R1037 5 ⁷ / ₁₆	R1037 8 3180 4 ¹⁵ / ₁₆	L	 Manual
250-300	R514 2 ⁷ / ₁₆ 3180 2 ³ / ₁₆	R3112 3 ⁷ / ₁₆ 3160 3 ³ / ₁₆	R3112 4 ¹⁵ / ₁₆ 3140 3 ¹⁵ / ₁₆	G		50-60	RX238 4 ⁷ / ₁₆	AX1568 5 ⁷ / ₁₆	R1037 8	M	
200-250	R514 2 ⁷ / ₁₆	R3112 3 ⁷ / ₁₆ 3160 3 ³ / ₁₆	R3112 4 ¹⁵ / ₁₆ 3140 3 ¹⁵ / ₁₆	G		45-50	RX238 4 ⁷ / ₁₆	RX238 7	R1037 8	M	
175-200	R514 2 ¹⁵ / ₁₆	1030 5 ¹⁵ / ₁₆ 3160 3 ³ / ₁₆	R3112 4 ¹⁵ / ₁₆ 3140 3 ¹⁵ / ₁₆	H		40-45	RX1248 4 ⁷ / ₁₆	RX2368 7	AX1568 8 ¹ / ₂	N	
150-175	R1033 3 ⁵ / ₁₆	1030 5 ¹⁵ / ₁₆ 3160 3 ³ / ₁₆	R3112 4 ¹⁵ / ₁₆ 3160 4 ⁷ / ₁₆	H		35-40	R1248 5 ⁷ / ₁₆	RX238 7	RX238 10	O	
125-150	R1037 3 ⁷ / ₁₆	1030 5 ¹⁵ / ₁₆ 3180 3 ¹¹ / ₁₆	R3112 4 ¹⁵ / ₁₆ 3160 4 ⁷ / ₁₆	I		30-35	RX1245 5 ⁷ / ₁₆	R1248 8	RX238 10	O	
100-125	R1037 3 ¹⁵ / ₁₆	R1033 5 ¹⁵ / ₁₆ 3180 3 ¹¹ / ₁₆	1030 7 3160 4 ⁷ / ₁₆	J		25-30	RO635 5 ⁷ / ₁₆	R1248 8	RX238 10	O	
90-100	R1037 3 ¹⁵ / ₁₆	R1035 5 ⁷ / ₁₆ 3180 3 ¹¹ / ₁₆	1030 7 3180 4 ¹⁵ / ₁₆	J		20-25	RO635 5 ⁷ / ₁₆	RO635 9 ¹ / ₂	FR1248 10	P	
80-90	R1037 3 ¹⁵ / ₁₆	R1037 5 ⁷ / ₁₆	R1033 7 ¹ / ₂ 3180 4 ¹⁵ / ₁₆	K		17 ¹ / ₂ - 20	RX1207 6 ¹ / ₂	RX635 9 ¹ / ₂	RX1245 10	Q	
70-80	AX1568 3 ¹¹ / ₁₆	R1037 5 ⁷ / ₁₆	R1035 8 3180 4 ¹⁵ / ₁₆	L		15 - 17 ¹ / ₂	RX1207 6 ¹ / ₂	RO635 9 ¹ / ₂	RO635 ①	Q	
						12 ¹ / ₂ - 15	RX1207 6 ¹ / ₂	RX1207 ①	RO635 ①	R	
						10 - 12 ¹ / ₂	RO1306 9	RX1207 ①	RX1207 ①	S	
					7 ¹ / ₂ - 10	RO1306 9	RO1306 ①	RX1207 ①	T		
					5 - 7 ¹ / ₂	X1307 10	RO1306 ①	RO1306 ①	U		
					4-5	X1307 9 ¹ / ₂	RO1306 ①	RO1306 ①	W		
					3-4	1	RO1306 ①	RO1306 ①	X		
45 DHP											
300-350	R514 2 ⁷ / ₁₆ 3180 2 ³ / ₁₆	R3112 3 ⁷ / ₁₆ 3160 3 ³ / ₁₆	R3112 4 ¹⁵ / ₁₆ 3140 3 ¹⁵ / ₁₆	G	 Oil Bath	175-200	R1033 3 ¹⁵ / ₁₆	1033 5 ¹⁵ / ₁₆ 3160 3 ³ / ₁₆	R3112 4 ¹⁵ / ₁₆ 3140 3 ¹⁵ / ₁₆	H	 Oil Bath
250-300	R514 2 ⁷ / ₁₆	R3112 3 ⁷ / ₁₆ 3160 3 ³ / ₁₆	R3112 4 ¹⁵ / ₁₆ 3140 3 ¹⁵ / ₁₆	G		150-175	R1037 3 ³ / ₁₆	1030 5 ¹⁵ / ₁₆ 3180 3 ¹¹ / ₁₆	R3112 4 ¹⁵ / ₁₆ 3160 4 ⁷ / ₁₆	I	
300-250	R1033 3 ¹⁵ / ₁₆	1030 5 ¹⁵ / ₁₆ 3160 3 ³ / ₁₆	R3112 4 ¹⁵ / ₁₆ 3140 3 ¹⁵ / ₁₆	H		125-150	R1037 3 ⁷ / ₁₆	R1033 5 ¹⁵ / ₁₆ 3180 3 ¹¹ / ₁₆	1030 6 ¹ / ₂ 3160 4 ⁷ / ₁₆	I	

① Contact Rexnord for details.







② Hub size letter – See page 70.

Notes: 3100 Series chain operates over roller chain cut tooth sprockets. Fabricated steel sprockets are recommended.

Design and Selection

Table 2 (Cont'd)
Drive Chain Selection Tables

Note: Rexnord drive chain selections are displayed in the tables. To interchange Link-Belt and Rexnord chain numbers see page 65.









Design Horsepower (DHP) = HP x SF For (SF) see page 92-93					Design Horsepower (DHP) = HP x SF For (SF) see page 92-93					
RPM Driver Sprocket	Driver Sprocket - No. Of Teeth Largest Keyseat Bore			Type of Lubrication	RPM Driver Sprocket	Driver Sprocket - No. Of Teeth Largest Keyseat Bore			Type of Lubrication	
	9T	12T	15T			Hub Letter ②	9T	12T		15T
45 DHP - Cont'd.										
100-125	R1037 3 ¹⁵ / ₁₆	R1035 5 ⁷ / ₁₆ 3180 3 ¹¹ / ₁₆	R1033 7 3180 4 ¹⁵ / ₁₆	J	30-35	RO635 5 ⁷ / ₁₆	R1248 8	RX238 10	O	
90-100	AX1568 3 ¹¹ / ₁₆	R1037 5 ⁷ / ₁₆	R1033 7 1/2 3180 4 ¹⁵ / ₁₆	K	25-30	RO635 5 ⁷ / ₁₆	RX1245 8	RX1248 10	P	
80-90	RX238 4 ⁷ / ₁₆	R1037 5 ⁷ / ₁₆	R1035 7 ¹ / ₂ 3180 4 ¹⁵ / ₁₆	K	Oil Bath	20-25	RX1207 6 ¹ / ₂	RO635 9 ¹ / ₂	RX1245 10	Q
70-80	RX238 4 ⁷ / ₁₆	R1037 5 ⁷ / ₁₆	1037 8	L		17 1/2 - 20	RX1207 6 ¹ / ₂	RO635 9 ¹ / ₂	RO635 ①	Q
60-70	RX23/ 4 ⁷ / ₁₆	AX1568 5 ⁷ / ₁₆	1037 8	L		15 - 17 1/2	RX1207 6 ¹ / ₂	RO635 9 ¹ / ₂	RO635 ①	Q
50-60	R1248 4 ⁷ / ₁₆	RX238 7	1037 8	M	12 1/2 - 15	RO1306 9	RX1207 ①	RO635 ①	R	
45-50	R1248 4 ⁷ / ₁₆	RX238 7	AX1568 8 ¹ / ₂	N	10 - 12 1/2	RO1306 9	RX1207 ①	RX1207 ①	S	
40-45	R1248 4 ⁷ / ₁₆	RX238 7	RX238 10	N	7 1/2 - 10	X1307 10	RO1306 ①	RX1207 ①	T	
35-40	RX1245 5 ⁷ / ₁₆	R1248 8	RX238 10	O	5 - 7 1/2	X1307 9 ¹ / ₂	RO1306 ①	RO1306 ①	V	
					4 - 5	1	RO1306 ①	RO1306 ①	W	
					3 - 4	1	1	RO1306 ①	Y	
50 DHP										
300-350	R514 2 ⁷ / ₁₆	R514 4 ⁷ / ₁₆ 3160 3 ³ / ₁₆	R3112 4 ¹⁵ / ₁₆ 3140 3 ¹⁵ / ₁₆	G	60-70	RX238 4 ⁷ / ₁₆	RX238 7	R1037 8	M	
250-300	R1035 3 ¹⁵ / ₁₆	R514 4 ⁷ / ₁₆ 3160 3 ³ / ₁₆	R3112 4 ¹⁵ / ₁₆ 3140 3 ¹⁵ / ₁₆	G	50-60	R1248 4 ⁷ / ₁₆	RX238 7	AX1568 8 ¹ / ₂	N	
200-250	R10358 3 ¹¹ / ₁₆	1030 5 ¹⁵ / ₁₆ 3160 3 3/16	R3112 4 ¹⁵ / ₁₆ 3140 3 ¹⁵ / ₁₆	H	45-50	R1248 4 ⁷ / ₁₆	RX238 7	RX238 9	N	
175-200	R1037 3 ⁷ / ₁₆	R1033 5 ¹⁵ / ₁₆ 3180 3 ¹¹ / ₁₆	R3112 4 ¹⁵ / ₁₆ 3160 4 ⁷ / ₁₆	I	40 - 45	RX1245 5 ⁷ / ₁₆	RX238 7	RX238 9 ¹ / ₂	O	
150-175	R1037 3 ⁷ / ₁₆	R1033 5 ¹⁵ / ₁₆ 3180 3 ¹¹ / ₁₆	1033 6 ¹ / ₂ 3160 4 ⁷ / ₁₆	I	35-40	RO635 5 ⁷ / ₁₆	R1248 8	RX238 9 ¹ / ₂	O	
125-150	R1037 3 ¹⁵ / ₁₆	R1033 5 ¹⁵ / ₁₆ 3180 3 ¹¹ / ₁₆	1030 7 3160 4 ⁷ / ₁₆	J	30-35	RO635 5 ⁷ / ₁₆	RX1245 8	R1248 10	P	
100-125	R1037 3 ¹⁵ / ₁₆	R1037 5 ⁷ / ₁₆ 3180 3 ¹¹ / ₁₆	R1033 7 ¹ / ₂ 3180 4 ¹⁵ / ₁₆	K	25-30	RO635 5 ⁷ / ₁₆	RP635 9 ¹ / ₂	R1248 10	P	
90-100	AX1568 3 ¹¹ / ₁₆	R1037 5 ⁷ / ₁₆	R1035 7 ¹ / ₂ 3180 4 ¹⁵ / ₁₆	K	20-25	RX1207 6 ¹ / ₂	RO635 9 ¹ / ₂	RO635 ①	Q	
80-90	RX238 4 ⁷ / ₁₆	R1037 5 ⁷ / ₁₆	1037 8 3180 4 ¹⁵ / ₁₆	L	17 1/2 - 20	RX1207 6 ¹ / ₂	RO635 9 ¹ / ₂	RO635 ①	Q	
70-80	RX238 4 ⁷ / ₁₆	R1037 5 ⁷ / ₁₆	1037 8	L	15 - 17 1/2	EO1306 9	RX1207 ①	RO635 ①	R	
					12 1/2 - 15	RO1306 9	RX1207 ①	RX1207 ①	S	
					10 - 12 1/2	RO1306 9	RO1306 ①	RX1207 ①	S	
					7 1/2 - 10	X1307 10	RO1306 ①	RO1306 ①	U	
					5 - 7 1/2	X1307 9 ¹ / ₂	RO1306 ①	RO1307 ①	W	
					4 - 5	1	X1307 ①	RO1306 ①	X	
					3 - 4	1	1	X1307 ①	Z	
60 DHP										
300-350	R1035 3 ¹⁵ / ₁₆	R514 4 ⁷ / ₁₆ 3160 3 3/16	R3112 4 ¹⁵ / ₁₆ 3140 3 ¹⁵ / ₁₆	G	70-80	RX238 4 ⁷ / ₁₆	RX238 7	R1037 8	M	
250-300	R1037 3 ¹¹ / ₁₆	R514 4 ⁷ / ₁₆ 3180 3 ¹¹ / ₁₆	R3112 4 ¹⁵ / ₁₆ 3160 4 ⁷ / ₁₆	H	60-70	R1248 4 ⁷ / ₁₆	RX238 7	AX1568 8 ¹ / ₂	N	
200-250	R1037 3 ⁷ / ₁₆	R1033 5 ¹⁵ / ₁₆ 3180 3 ¹¹ / ₁₆	1030 6 ¹ / ₂ 3160 4 ⁷ / ₁₆	I	50-60	RX1245 5 ⁷ / ₁₆	RX238 7	RX238 9 ¹ / ₂	O	
175-200	R1037 3 ⁷ / ₁₆	R1033 5 ¹⁵ / ₁₆ 3180 3 ¹¹ / ₁₆	1030 6 ¹ / ₂ 3160 4 ⁷ / ₁₆	I	45-50	RO635 5 ⁷ / ₁₆	R1248 8	RX238 9 ¹ / ₂	O	
150-175	R1037 3 ¹⁵ / ₁₆	R1033 5 ¹⁵ / ₁₆ 3180 3 ¹¹ / ₁₆	1033 7 3180 4 ¹⁵ / ₁₆	J	40-45	RO635 5 ⁷ / ₁₆	RX1245 8	R1248 10	P	
125- 150	AX1568 3 ¹¹ / ₁₆	R1037 5 ⁷ / ₁₆	R1033 7 3180 4 ¹⁵ / ₁₆	J	35-40	RO635 5 ⁷ / ₁₆	RO635 9 ¹ / ₂	R1248 10	P	
100-125	RX238 4 ⁷ / ₁₆	R1037 5 ⁷ / ₁₆	1037 7 ¹ / ₂ 3180 4 ¹⁵ / ₁₆	K	30-35	RO635 5 ⁷ / ₁₆	RO635 9 ¹ / ₂	R1248 10	P	
90-100	RX238 4 ⁷ / ₁₆	R1037 5 ⁷ / ₁₆	1037 8	L	25-30	RX1207 6 ¹ / ₂	RO635 9 ¹ / ₂	RO635 ①	Q	
80-90	RX238 4 ⁷ / ₁₆	AX1568 5 ⁷ / ₁₆	1037 8	L	20-25	RX1207 6 ¹ / ₂	RO635 9 ¹ / ₂	RO635 ①	Q	
					17 1/2 - 20	RO1306 9	RX1207 ①	RO635 ①	R	
					15 - 17 1/2	RO1306 9	RX1207 ①	RX1207 ①	S	
					12 1/2 - 15	RO1306 9	RO1306 ①	RX1207 ①	S	
					10 - 12 1/2	RO1306 9	RO1306 ①	RX1207 ①	T	
					7 1/2 - 10	X1307 10	RO1306 ①	RO1306 ①	U	

① Contact Rexnord for details.
② Hub size letter – See page 70.
Notes: 3100 Series chain operates over roller chain cut tooth sprockets.
Fabricated steel sprockets are recommended.

Design and Selection

Table 2 (Cont'd)
Drive Chain Selection Tables

Note: Rexnord drive chain selections are displayed in the tables. To interchange Link-Belt and Rexnord chain numbers see page 65.

RPM Driver Sprocket	Design Horsepower (DHP) = HP x SF For (SF) see page 92-93				Type of Lubrication	RPM Driver Sprocket	Design Horsepower (DHP) = HP x SF For (SF) see page 92-93				Type of Lubrication
	Driver Sprocket - No. Of Teeth Largest Keyseat Bore						Driver Sprocket - No. Of Teeth Largest Keyseat Bore				
	9T	12T	15T	Hub Letter ②			9T	12T	15T	Hub Letter ②	
70 DHP											
300-350	-	R514 4 ^{7/16} 3180 3 ^{11/16}	R514 5 ^{15/16} 3160 4 ^{7/16}	H	 Oil Bath	60-70	RX1245 5 ^{7/16}	RX238 7	RX238 9 ^{1/2}	O	 Oil Bath
250-300	R1037 3 ^{7/16}	1030 5 ^{15/16} 3180 3 ^{11/16}	R514 5 ^{15/16} 3160 4 ^{7/16}	I		50 - 60	RO635 5 ^{7/16}	R1248 8	RX238 9 ^{1/2}	O	
200-250	R1037 3 ^{7/16}	R1033 5 ^{15/16} 3180 3 ^{11/16}	R1033 6 ^{1/2} 3160 4 ^{7/16}	I		45 - 50	RO635 5 ^{7/16}	R1248 8	RX238 9 ^{1/2}	O	 Flow
175 - 200	R1037 3 ^{15/16}	R1033 5 ^{15/16} 3180 3 ^{11/16}	R1033 7 3180 4 ^{15/16}	J		40 - 45	RO635 5 ^{7/16}	RX1245 8	R1248 10	P	
150-175	AX1568 3 ^{11/16}	R1037 5 ^{7/16}	R1033 7 3180 4 ^{15/16}	J		35 - 40	RX1207 6 ^{1/2}	RO635 9 ^{1/2}	R1248 10	P	
125-150	RX238 4 ^{7/16}	R1037 5 ^{7/16}	R1035 7 ^{1/2} 3180 4 ^{15/16}	K		30 - 35	RX1207 6 ^{1/2}	RO635 9 ^{1/2}	RO635 ①	Q	
100-125	RX238 4 ^{7/16}	R1037 5 ^{7/16}	R1037 8	L		25 - 30	RX1207 6 ^{1/2}	RO635 9 ^{1/2}	RO635 ①	Q	
90-100	RX238 4 ^{7/16}	AX1568 5 ^{7/16}	R1037 8	M		20-25	RO1306 9	RX1207 ①	RO635 ①	R	
80-90	R1248 4 ^{7/16}	RX238 7	R1037 8	M		17 ^{1/2} -20	RO1306 9	RX1207 ①	RX1207 ①	S	
70-80	R1248 4 ^{7/16}	RX238 7	AX1568 8 ^{1/2}	N		15 - 17 ^{1/2}	RO1306 9	RO1306 ①	RX1207 ①	S	
						12 ^{1/2} -15	RO1306 9	RO1306 ①	RX1207 ①	T	
						10 - 12 ^{1/2}	X1307 10	RO1306 ①	RO1306 ①	U	
						7 ^{1/2} -10	1	RO1306 ①	RO1306 ①	V	
						5 - 7 ^{1/2}	1	X1307 ①	X1307 ①	Y	Manual
80DHP											
300-350	-	R1035 5 ^{7/16} 3180 3 ^{11/16}	R514 5 ^{15/16} 3160 4 ^{7/16}	H	 Oil Bath	50 - 60	RO635 5 ^{7/16}	R1248 8	RX238 9 ^{1/2}	O	 Oil Bath
250-300	AX1568 2 ^{15/16}	R1035 5 ^{7/16} 3180 3 ^{11/16}	R514 5 ^{15/16} 3180 4 ^{15/16}	I		45 - 50	RO635 5 ^{7/16}	RO635 9 ^{1/2}	R1248 10	P	
200-250	AX1568 3 ^{11/16}	R1035 5 ^{7/16} 3180 3 ^{11/16}	R1033 7 3180 4 ^{15/16}	J		40 - 45	RX1207 6 ^{1/2}	RO635 9 ^{1/2}	48 10	P	 Flow
175-200	AX1568 3 ^{11/16}	R1037 5 ^{7/16}	R1033 7 3180 4 ^{15/16}	J		35 - 40	RX1207 6 ^{1/2}	RO635 9 ^{1/2}	RO635 ①	Q	
150-175	RX238 4 ^{7/16}	R1037 5 ^{7/16}	R1035 7 ^{1/2} 3180 4 ^{15/16}	K		30 - 35	RX1207 6 ^{1/2}	RO635 9 ^{1/2}	RO635 ①	Q	
125-150	RX238 4 ^{7/16}	R1037 5 ^{7/16}	R1037 8	L		25 - 30	RO1306 9	RX1207 ①	RO635 ①	R	
100-125	RX238 4 ^{7/16}	AX1568 5 ^{7/16}	R1037 8	M		20 - 25	RO1306 9	RX1207 ①	RX1207 ①	S	
90-100	R1248 4 ^{7/16}	RX238 7	AX1568 8 ^{1/2}	M		17 ^{1/2} -20	RO1306 9	RO1306 ①	RX1207 ①	S	
80-90	RX1245 4 ^{7/16}	RX238 7	AX1568 8 ^{1/2}	N		15 - 17 ^{1/2}	RO1306 9	RO1306 ①	RX1207 ①	T	
70-80	RO635 5 ^{7/16}	RX238 7	RX238 9 ^{1/2}	O		12 ^{1/2} -15	RO1306 8 ^{1/2}	RO1306 ①	RO1306 ①	U	
60-70	RO635 5 ^{7/16}	R1248 8	RX238 9 ^{1/2}	O		10 - 12 ^{1/2}	1	RO1306 ①	RO1306 ①	U	
						7 ^{1/2} -10	1	X1307 ①	RO1306 ①	W	
						5 - 7 ^{1/2}	1	1	RO1307 ①	Y	Manual
90 DHP											
300-350	-	R1035 5 ^{7/16} 3180 3 ^{11/16}	R514 5 ^{15/16} 3160 4 ^{7/16}	I	 Oil Bath	60 - 70	RO635 5 ^{7/16}	R1248 8	RX238 9 ^{1/2}	O	 Oil Bath
250-300	AX1568 2 ^{15/16}	R1035 5 ^{7/16} 3180 3 ^{11/16}	R514 5 ^{15/16} 3180 4 ^{15/16}	I		50 - 60	RO635 5 ^{7/16}	RO635 9 ^{1/2}	R1248 10	P	
200-250	AX1568 3 ^{11/16}	R1037 5 ^{7/16}	R514 5 ^{15/16} 3180 4 ^{15/16}	J		45 - 50	RX1207 6 ^{1/2}	RO635 9 ^{1/2}	R1248 10	P	 Flow
175-200	RX238 4 ^{7/16}	R1037 5 ^{7/16}	R1033 7 ^{1/2} 3180 4 ^{15/16}	K		40 - 45	RX1207 6 ^{1/2}	RO635 9 ^{1/2}	RO635 ①	Q	
150-175	RX238 4 ^{7/16}	R1037 5 ^{7/16}	R1037 7 ^{1/2}	K		35 - 40	RX1207 6 ^{1/2}	RO635 9 ^{1/2}	RO635 ①	Q	
125-150	RX238 3 ^{11/16}	AX1568 5 ^{7/16}	R1037 8	L		30 - 35	RX1207 6 ^{1/2}	RO635 9 ^{1/2}	RO635 ①	Q	
100-125	R1248 4 ^{7/16}	RX238 7	AX1568 8 ^{1/2}	M		25 - 30	RX1207 6 ^{1/2}	RX1207 ①	RO635 ①	R	
90-100	RX1245 4 ^{7/16}	RX238 7	AX1568 8 ^{1/2}	N		20 - 25	RO1306 9	RO1306 ①	RX1207 ①	S	
80-90	RO635 5 ^{7/16}	RX238 7	RX238 9 ^{1/2}	O		17 ^{1/2} -20	RO1306 9	RO1306 ①	RX1207 ①	S	
70-80	RO635 5 ^{7/16}	R1248 8	RX238 9 ^{1/2}	O		15 - 17 ^{1/2}	X1307 10	RO1306 ①	RO1306 ①	T	
						12 ^{1/2} -15	1	RO1306 ①	RO1306 ①	U	
						10 - 12 ^{1/2}	1	RO1306 ①	RO1306 ①	V	

① Contact Rexnord for details.







② Hub size letter - See page 70.

Notes: 3100 Series chain operates over roller chain cut tooth sprockets. Fabricated steel sprockets are recommended.

Design and Selection

Table 2 (Cont'd)
Drive Chain Selection Tables

Note: Rexnord drive chain selections are displayed in the tables. To interchange Link-Belt and Rexnord chain numbers see page 65.

Design Horsepower (DHP) = HP x SF For (SF) see page 92-93					Design Horsepower (DHP) = HP x SF For (SF) see page 92-93						
RPM Driver Sprocket	Driver Sprocket - No. Of Teeth Largest Keyseat Bore			Hub Letter ②	Type of Lubrication	RPM Driver Sprocket	Driver Sprocket - No. Of Teeth Largest Keyseat Bore			Hub Letter ②	Type of Lubrication
	9T	12T	15T				9T	12T	15T		
100 DHP											
300 – 350	-	3180 3 ^{11/16}	R514 5 ^{15/16} 3180 4 ^{15/16}	I	 Oil Bath	50 – 60	RX1207 6 ^{1/2}	RO635 9 ^{1/2}	R1248 10	P	 Flow
250 – 300	-	R1037 5 ^{7/16}	R1035 7 3180 4 ^{15/16}	J		45 – 50	RX1207 6 ^{1/2}	RO635 9 ^{1/2}	RX1245 10	P	
200 – 250	-	R1037 5 ^{7/16}	R1035 7 ^{1/2} 3180 4 ^{15/16}	K		40 – 45	RX1207 6 ^{1/2}	RO635 9 ^{1/2}	RO635 ①	Q	
175 – 200	-	R1037 5 ^{7/16}	R1037 7 ^{1/2}	K		35 – 40	R1305 9	RO635 9 ^{1/2}	RO635 ①	R	
150 – 175	RX238 4 ^{7/16}	R1037 5 ^{7/16}	R1037 8	L		30 – 35	RO1306 9	RX1207 ①	RO635 ①	R	
125 – 150	R1248 4 ^{7/16}	RX238 7	R1037 8	M		25 – 30	RO1306 9	RX1207 ①	RX1207 ①	S	
100 – 125	RX1245 4 ^{7/16}	RX238 7	AX1568 8 ^{1/2}	N		20 – 25	RO1306 9	RO1306 ①	RX1207 ①	S	
90 – 100	RO635 5 ^{7/16}	RX238 7	RX238 9	N		17 1/2 – 20	RO1306 9	RO1306 ①	RX1207 ①	T	
80 – 90	RO635 5 ^{7/16}	R1248 8	RX238 9 ^{1/2}	O		15 – 17 1/2	1	RO1306 ①	RO1306 ①	U	
70 – 80	RO635 5 ^{7/16}	R1248 8	R238 9 ^{1/2}	O		12 1/2 – 15	1	RO1306 ①	RO1306 ①	U	
60 – 70	RX1245 5 ^{7/16}	RX1245 8	R1248 10	P	10 – 12 1/2	1	-	RO1306 ①	W		
						7 1/2 – 10	1	1	X1307 ①	X	
125 DHP											
200 – 250	-	AX1568 5 ^{7/16}	-	L	 Oil Bath	45 – 50	-	RO635 9 ^{1/2}	RO635 ①	Q	 Flow
175 – 200	-	AX1568 5 ^{7/16}	R1037 8	L		40 – 45	-	RX1207 ①	RO635 ①	R	
150 – 175	-	RX238 7	R1037 8	M		35 – 40	-	RX1207 ①	RO635 ①	R	
125 – 150	-	RX238 7	AX1568 7 ^{1/2}	N		30 – 35	-	RX1207 ①	RX1207 ①	S	
100 – 125	-	R1248 8	RX238 9 ^{1/2}	O		25 – 30	-	RO1306 ①	RX1207 ①	S	
90 – 100	-	R1248 8	RX238 9 ^{1/2}	O		20 – 25	-	RO1306 ①	RO1306 ①	T	
80 – 90	-	R1248 8	RX238 9 ^{1/2}	O		17 1/2 – 20	-	RO1306 ①	RO1306 ①	U	
70 – 80	-	RO635 9 ^{1/2}	R1248 10	P		15 – 17 1/2	-	RO1306 ①	RO1306 ①	V	
60 – 70	-	RO635 9 ^{1/2}	R1248 10	P		12 1/2 – 15	-	1	RO1306 ①	W	
50 – 60	-	RO635 9 ^{1/2}	RO635 ①	Q							
150 DHP											
175 – 200	-	-	R1037 8	M	 Oil Bath	45 – 50	-	-	RO635 ①	-	 Flow
150 – 175	-	-	AX1568 7 ^{1/2}	N		40 – 45	-	-	RX1207 ①	-	
125 – 150	-	-	RX238 9 ^{1/2}	O		35 – 40	-	-	RX1207 ①	-	
100 – 125	-	-	RX238 9 ^{1/2}	O		30 – 35	-	-	RX1207 ①	-	
90 – 100	-	-	R1248 10	P		25 – 30	-	RO1306 ①	RO1306 ①	-	
80 – 90	-	-	R1248 10	P		20 – 25	-	RO1306 ①	RO1306 ①	-	
70 – 80	-	-	RX1245 10	P		17 1/2 – 20	-	1	RO1306 ①	-	
60 – 70	-	-	RO635 ①	Q		15 – 17 1/2	-	1	RO1306 ①	-	
50 – 60	-	-	RO635 ①	Q		12 1/2 – 15	-	1	RO1306 ①	-	

① Contact Rexnord for details.

② Hub size letter – See page 70.

Notes: 3100 Series chain operates over roller chain cut tooth sprockets. Fabricated steel sprockets are recommended.

Design and Selection

Conveyor Chain Selection Procedures

Conveyor Classes

A consideration closely related to the type of conveyor chain is the conveyor class. Six conveyor classes have been established on the basis of friction factors involved with the movement of the chain (sliding or rolling) and the movement of the material (sliding or carried). These six classes are described in terms of chain and material movement in the following table:

Conveyor Classes		
Class	Chain	Material
1	Sliding, with flights	Sliding
1A	Sliding, without flights	Sliding
2	Rolling	Sliding
3	Sliding	Carried
4	Rolling	Carried
4A	Supplemental Roller	Carried

Basic Conveyor Arrangements

There are several basic conveyor arrangements. The recommended arrangement (see illustration) is with the drive at the head end and with the carrying and return runs well supported. Note the catenary sag in the return run at the head end. In general, the catenary sag should be at least equal to 3% of the span over which the chain is hanging. The illustrated arrangement offers two advantages:

- The catenary force tends to keep the chain engaged on the drive sprocket.
- Wear at the chain joints is minimal because the return run is under minimum tension and flexure at the chain joints is reduced by the well-supported return line.

If a take-up is used to adjust the center distance and maintain the correct catenary sag, be extremely cautious not to impose excessive loads on the chain.

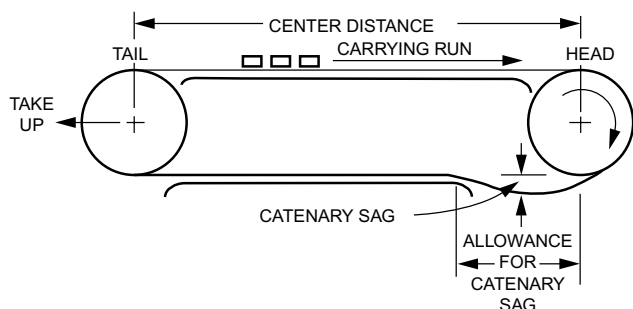

Other Arrangements

Other methods of supporting the return run are shown in the following illustrations.

These methods of support will result in faster chain wear because of the additional flexure at the joints in the return line and the higher pressure between the chain and the return support because of the small area of support.

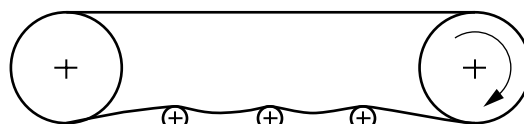

Return Strand Supported by Rollers

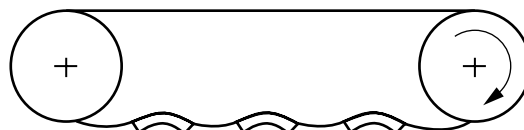

Return Strand Supported by Shoes

Conveyors sometimes are driven from the tail end as shown in the following illustration.

This arrangement is not recommended for two main reasons:

- Chain wear at the joints is greater because chain is flexing under load at both the head and tail sprockets.
- Excess chain tends to accumulate on the carrying run just after the tail sprocket and the resulting wedging action can cause the chain to jump the sprocket.

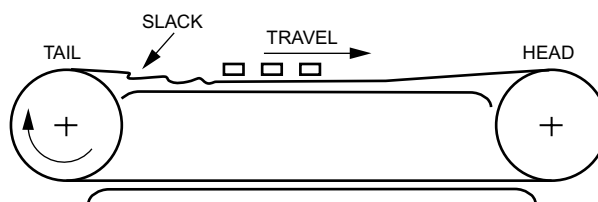

Design and Selection

Method of Chain Travel

Another basic consideration is whether the chain will slide or roll. In deciding on the method of chain travel, the following points should be evaluated:

Chain Sliding

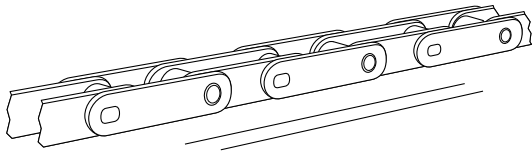

- Simple in construction, fewer moving parts and usually the lowest in cost for a given load.
- Most effective in “dirty” applications.
- Greater horsepower required.

Chain Rolling

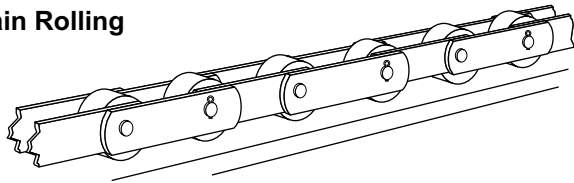

- Smoother operation, less pulsation.
- Lower friction which permits longer centers, smaller motors, and lower operating costs.
- Not suited to “dirty” applications, foreign matter jams rollers.
- Less horsepower required.

Conveyor Pulsation

Another consideration is the amount of pulsation that can be tolerated in the conveyor. This will vary from one installation to another and the permissible amount is a matter of judgement. When pulsation must be minimized, consider the possible causes and remedies listed in the following table:

Possible Cause	Remedy
Excessive friction	Clean and lubricate moving parts.
Conveyor too long	Use shorter conveyor sections.
Conveyor speed too low (10 FPM or less)	Increase conveyor speed, or use non-metallic bushed chain.
Velocity fluctuation caused by chordal action	Use drive sprocket with 12 or more teeth, or use compensating sprocket. (Contact your Rexnord representative.)

Carrying Loads of Rollers

A basic consideration on conveyors using chain with rollers is the load imposed on the chain. This load includes the weight of the slats or flights, and the weight of the material being carried. This load must be limited so that the pressure of the bushing on the roller is kept within permissible limits.

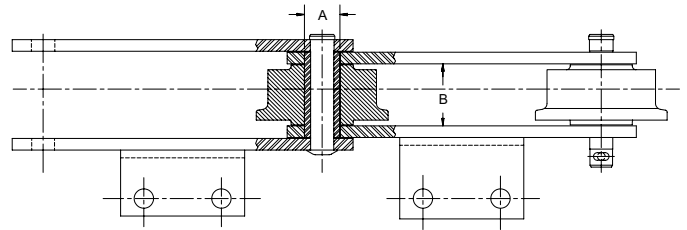

A = Roller-bore diameter
B = Roller hub length } Applies also to outboard rollers.

Roller-bearing area = A x B

The roller carrying pressure, per roller, is distributed over the roller-bearing area.

The table below lists allowable bearing pressures between bushings and roller. Note the method of determining the roller bearing area. The listed bearing pressures are for “ideal conditions”, i.e. slow speeds in non-gritty service with lubricated bearings. As any of these conditions become more severe, the allowable pressures must be reduced accordingly.

The allowable working bearing pressures, in pounds per square inch between rollers and bushings, are approximately as follows:

Roller and Bushing Materials in Contact	Allowable Bearing Pressure P.S.I.
Case-hardened steel against case-hardened steel	1400
Case-hardened steel against white iron	1400
Case-hardened steel against untreated steel	1200
Case-hardened steel against cast iron	1000 ①
Case-hardened steel against malleable iron	1000
Case-hardened steel against bronze	400
Gray iron against malleable iron	800
Malleable iron against malleable iron	800
Gray iron against bronze	800
Non-metallic against carburized steel or heat treated stainless steel (LF bushed rollers)	100

① Applies also to chill iron.

Design and Selection

Conveyor Chain Selection Procedures – (Cont'd.)

Wear Strips and Ways

Generally, it is desirable that the chain wear slower than the wear strips or liner since it is the more critical and expensive part of the conveyor components. Therefore, the most compatible wear strip should be considered after the proper chain has been selected. Conveyor may experience wear even with the chain rolling instead of sliding. This wear is not a critical consideration but cold finished steel should be used for best operation.

The subject of wear is extremely complicated and influenced by many factors. It is impossible to predict with accuracy the wear life of various chain – liner combinations. This is due to the effect of many variable and uncontrollable factors such as abrasion, corrosion, lubrication, load, speed, and break-in period. Thus, prior experience of a successful chain – liner combination for a specific application is the best guide to predict performance.

For new installations, where no previous experience can be applied as a guide, a metal liner should be used where chain is slightly harder than the liner. This will protect the chain by ensuring the liner wear first. The material should be at least comparable to the chain in surface finish or smoother.

Non-metallic materials such as wood and plastic are occasionally used as liner materials. These may result in wear strip economy, but should not be used where severe impacting loads exist or under extremely dirty conditions.

If wear is a problem, neglecting the effect of corrosion, experience has shown that generally by increasing the hardness of either the chain or the metallic wear strip in an abrasive environment should decrease the wear on both. Lubrication, even if only water will reduce wear. Some general comments to insure proper installation of liners in the conveyor and things to do before start-up are:

1. See that the joints on the liners and frame are smooth so that no sharp edges protrude.
2. Take reasonable care in eliminating welding slag, weld spatter, metal filings and/or mill scale from the conveyor.
3. Break in chain and liner by operating the conveyor without load, and with plenty of lubricant, for a short period of time (generally 8-24 hours) or until the mating wear surfaces are polished smooth.

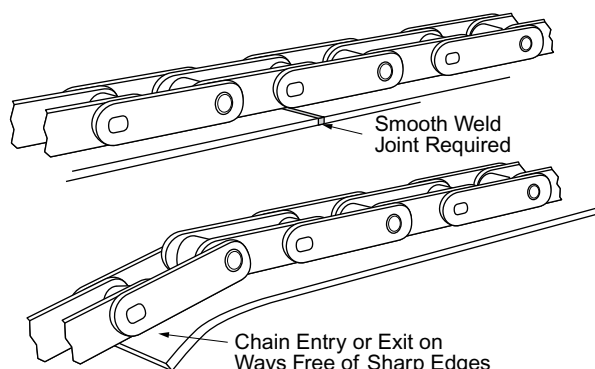

Note: The above comments are guidelines that normally will increase or improve chain liner compatibility.

Abrasion Resistant Steel Alloys That May Be Used As Liner Material

Name	Condition	Mechanical Properties		
		Hardness BHN	Yield 1000 PSI	Tensile 1000 PSI
SSS-321	Q & T	321	–	–
SSS-360	Q & T	360	–	–
SSS-400	Q & T	400	–	–
Sheffield AR	HR	225	–	–
AR-No. 235	HR	235	70	100
Abrasion Resisting, Med. Hard.	HR	235	–	–
Abrasion Resisting, Full Hard.	HR	270	–	–
Jalloy AR-280	Q & T	260	110	117
Jalloy AR-320	Q & T	300	135	142
Jalloy AR-360	Q & T	340	160	166
Jalloy AR-400	Q & T	400	184	190
Jalloy S-340	Q & T	320	149	157
Jalloy 3 (AR)	HR	225	90	104
T-1-A-360	Q & T	360	145	180
XAR-15	Q & T	360	165	180
XAR-30	Q & T	360	165	180
USS-AR	HR	235	–	100
T-1	Q & T	321	100	115
T-1-A	Q & T	321	100	115
T-1-A-321	Q & T	321	137	171
T-1-B-321	Q & T	321	137	171
T-1-321	Q & T	321	141	175
T-1-360	Q & T	360	145	180
Astralloy	N	440	141	228

Presented as a guide only. If additional information is required, contact the designated steel company.

Note: Q & T = quenched and tempered; HR = hot rolled; N = normalized. Typical values are enclosed in parentheses.

Mechanical properties are those of sheet or hot rolled plate up to 1/2" thick and are minimums unless typical is indicated by parentheses.

Design and Selection

This procedure is intended to serve primarily as a guide for selecting a general type, or class, of chain when a new conveyor is designed. When following the step-by-step instruction outlined, the user may find that more than one type of chain will fit the particular conveyor requirement. In such a case the final selection of the chain may be affected by such factors as allowable sprocket diameters, space limitations for chain, chain pitch, and many other environmental and design factors peculiar to the particular conveyor being designed. Contact your Rexnord representative for assistance in selecting the best chain when a choice of more than one class is indicated.

Parts of this section will prove useful in determining whether the chain on existing installations is the most economical choice, and will also serve as a guide to upgrading existing installations where service life is not satisfactory.

Procedure

There are six basic steps in selecting the proper type of chain for a conveyor installation.

1. Determine the class of conveyor.
2. Estimate the total chain pull.
3. Determine the design working load.
4. Make a tentative chain selection.
5. Make tentative selection of attachment links.
6. Verify chain selection and re-check design working load.

Step 1. Determine the Class of Conveyor

Check the sections on Conveyor Types, Conveyor Classes, and Method of Chain Travel in relation to your conveying problem. Make a tentative selection of a conveyor class required from the table on page 103.

Step 2. Estimate the Total Chain Pull (Pm).

Use the formula which applies to the conveyor class tentatively selected and calculate total chain pull (Pm) which is total conveyor chain pull. For conveyors that are partly horizontal and partly inclined, calculate the chain pull for each section, and add to obtain total chain pull. Note: Calculations assume properly adjusted take up equipment. If take-up force is adjusted to exceed the calculated value (P₂ + P₃), excessive chain loading may result.

Class 1, 1A and 2 Conveyors

(Chain sliding or rolling; Material sliding)

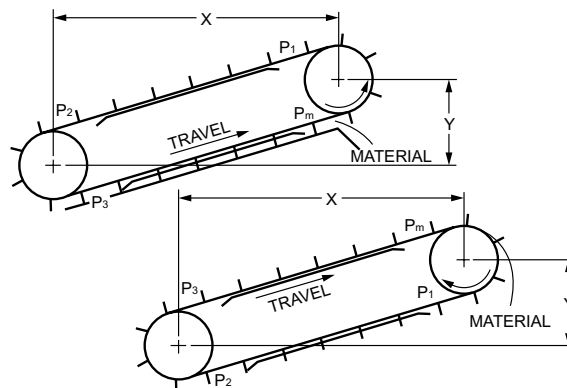

Formulas for Calculating Total Chain Pull (Pm)

Horizontal: $\left(\frac{Y}{X} \text{ is less than } f_1\right)$

$$P_m = X(2f_1W + f_2M + \frac{h^2}{C}) + MY$$

Inclined: $\left(\frac{Y}{X} \text{ is greater than } f_1\right)$

$$P_m = X(f_1W + f_2M + \frac{h^2}{C}) + Y(W + M)$$

Class 3, 4 and 4A Conveyors

(Chain sliding, rolling or in tension; Material carried)

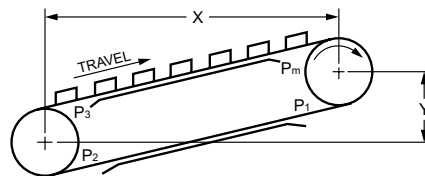

Formulas for Calculating Total Chain Pull (Pm)

Horizontal: $\left(\frac{Y}{X} \text{ is less than } f_1\right)$

$$P_m = f_1X(2W + M) + MY + \frac{h^2}{C}X$$

Inclined: $\left(\frac{Y}{X} \text{ is greater than } f_1\right)$

$$P_m = (M + W)(f_1X + Y) + \frac{h^2}{C}X$$

Formulas for Calculating Horsepower (HP)

Horizontal:
$$HP = \frac{1.15(S)(P_m)}{33,000}$$

Inclined:
$$HP = \frac{1.15(S)(P_m - P_1)}{33,000}$$

$$P_1 = W(Y - f_1X)$$

$$P_2 = P_3 = 0$$

Note: Symbol identification given on page 107.

Design and Selection

Conveyor Chain Selection Procedures – (Cont'd.)

Symbols

- f1** = Coefficient of Friction – chain sliding or rolling on runway. See next column for specific value of the coefficient.
If chain is supported by flights, etc., f1 should be coefficient for flights sliding on conveyor ways.
- f2** = Coefficient of Friction – material sliding on trough. (See Table in next column).
- M** = Weight of material handled per foot of conveyor (lb./ft.)

$$M = \frac{(TPH)(33.3)}{S}$$

$$M = \frac{(CFH) (\text{Mat'l. Density in LB/FT}^3)}{60(S)}$$
- W** = Weight of moving conveyor parts – chains, flights, slats, etc., per foot of chain (lbs/ft). Depending on the method of chain travel, use the following factors for estimating approximate chain weight (lbs/ft) if actual chain weight is unknown.
 Material or chain sliding – .0015 x Total weight of material on conveyor at any time (lbs.). (Classes 1, 1A, 2 or 3)
 Material carried and chain rolling .0005 x Total weight of material on conveyor at any time (lbs.). (Classes 4 and 4A)
For example: If a Class 4 Conveyor is used and the total material weight is 40,000 pounds, then 40,000 x .0005 = 20.0
 Use 20.0 Lbs/Ft. as an estimated chain weight for "W" in the above equation. Add the estimated Weight/Ft. on the flights or slats that will be used.
- h** = Height of material rubbing against side of conveyor trough (inches).
- c** = Trough side friction constant (see Table in next column).
- Pm** = Total Maximum chain pull (lbs)
- P1 }
P2 }
P3 }** Chain pull at point indicated (lbs)
- HP** = Required horsepower at headshaft
- S** = Conveyor Speed (ft/min)
- TPH** = Capacity in Tons per Hour = $\frac{MS}{33.3}$

- CFH** = Capacity in cubic feet per hour

$$= \frac{TPH \times 2000}{(\text{Mat'l. Density in lb/ft}^3)}$$
- X** = Horizontal center distance (ft.)
- Y** = Vertical rise (ft.)

Chain Friction Factors (f1)

Chain Sliding

- Chain Sliding on Steel Track – unlubricated3-.5
 Chain Sliding on Steel Track – lubricated2
 Chain Sliding on Hard Wood5
 Chain Sliding on Non-Metallic Wear Strips:
 Chain Sliding on Ultra-High Molecular
 Weight Polyethylene15-.4

Chain Rolling

$$f_r = f_r \frac{d_a}{d_r}$$

Where: d_a = axle diameter (inches)(usually bushing O.D.)
 d_r = roller outside diameter (inches)

(Fr) For Metal Rollers			
Cast Rollers		Steel Rollers	
Dry	.5	Dry	.4
Lubricated	.4	Lubricated	.3

For LF (Low Friction material) Bushed Rollers, $f_r = .25$

Material Friction Factors

Materials	Friction Factor Mat'l Sliding on Steel Trough (f2)	Trough Side Friction Factor (c)
Aluminum	.40	27
Ashes, Coal, Dry	.50	36
Ashed, Coal, Wet	.60	55
Bagasse	.40	200
Cement, Portland	.65	12
Cement Clinker	.70	12
Coal, Anthracite, Sized	.40	25
Coal, Anthracite, Run of Mine	.45	20
Coal, Bituminous, Sized	.50	21
Coal, Bituminous, Run of Mine	.55	20
Coke, Mixed	.55	42
Coke, Breeze	.65	36
Grains	.40	23
Gravel, Dry	.45	12
Gravel, Run of Bank	.60	11
Ice, Crushed	.15	34
Lime, Pebble	.50	28
Sand, Dry	.60	7
Sand, Damp	.85	6
Stone, Screened	.60	9
Wood Chips, Pulp Logs	.40	48

Design and Selection

Step 3. Determine the Design Working Load

The determination of chain pull (Pm) is for static conditions and does not include consideration of the following dynamic conditions:

- a. Loading fluctuations that may exceed the static load condition. These fluctuations are provided for by the Service Factor. (See table below.)
- b. The conveyor chain speed and the number of teeth in the sprockets used. These items are provided for by the Speed Factor (Fs). (See table below.)

Calculate the Design Working load by modifying Pm as follows:

For single strand conveyor:

$$\text{Design Working Load} = P_m \times \text{Service Factor} \times \text{Speed Factor}$$

For multiple strand conveyor:

$$\text{Design Working Load} = P_m \times \text{Service Factor} \times \text{Speed Factor} \times \frac{1.2}{\text{No. of Strands}}$$

The multiplier (1.2) is used to provide for possible overloads in one of the strands caused by unequal load sharing distribution.

Speed Factors (Fs)

No. of Teeth on Sprocket	50		100		150		200		300		400	
	Cast Chain	Engineered and Welded Steel Chain	Cast Chain	Engineered and Welded Steel Chain	Cast Chain	Engineered and Welded Steel Chain	Cast Chain	Engineered and Welded Steel Chain	Cast Chain	Engineered and Welded Steel Chain	Cast Chain	Engineered and Welded Steel Chain
6	1.6	1.4	2.3	2.0	2.3	2.9	5.0	4.4	—	—	—	—
7	1.3	1.1	1.6	1.4	2.0	1.8	2.6	2.3	4.5	4.0	—	—
8	1.2	1.0	1.4	1.3	1.7	1.5	2.0	1.8	2.9	2.5	4.2	3.6
9	1.1	1.0	1.3	1.2	1.6	1.4	1.8	1.6	2.3	2.0	2.9	2.6
10	1.0	0.9	1.3	1.1	1.4	1.2	1.6	1.4	1.9	1.7	2.3	2.0
11	1.0	0.9	1.2	1.0	1.3	1.2	1.5	1.3	1.7	1.5	2.1	1.8
12	1.0	0.9	1.1	1.0	1.3	1.1	1.4	1.2	1.6	1.4	1.9	1.6
14	1.0	0.8	1.1	0.9	1.2	1.0	1.3	1.1	1.5	1.3	1.7	1.4
16	0.9	0.8	1.0	0.9	1.1	1.0	1.2	1.0	1.4	1.2	1.5	1.3
18	0.9	0.8	1.0	0.9	1.0	0.9	1.2	1.0	1.3	1.1	1.5	1.3
20	0.9	0.8	1.0	0.9	1.0	0.9	1.1	1.0	1.3	1.1	1.5	1.2
24	0.9	0.8	0.9	0.8	1.0	0.9	1.1	0.9	1.2	1.0	1.3	1.2

Note: If sprocket size has not yet been determined, use a speed factor for a 12-tooth sprocket. Refer to sprocket selection beginning on page 75.

Determination of Speed Factor for Traction Wheels

1. Determine effective pitch diameter (PDeff): (PDeff) = Traction wheel O.D. + barrel O.D. (chain)
2. Compare (PDeff) to pitch diameters of standard engineering sprockets. If (PDeff) falls between two standard pitch diameters, go to the lower value.
3. The standard pitch diameter chosen from No. 2 above will give the number of teeth.
4. Knowing the number of teeth and chain speed, speed factor (Fs) can be determined.

Service Factor

Type of Load	Operating Conditions ^①		Daily Operated Period	
	Start Stop Frequency Under Load	% Load Added At a Time	8-10 Hrs.	24 Hrs.
Uniform	Less Than 5/Day	Less Than 5%	1.0	1.2
Moderate Peaks	5/Day to 2/Hr.	5-20%	1.2	1.4
High Peaks	2/Hr. to 10/Hr.	20% to 40%	1.5	1.8
	Operating Conditions		Service Factors	
Temperature	Up to 200°F (93°C)		1.0	
	200°F to 350°F (93°C to 177°C)		1.1	
	350°F to 500°F (177°C to 260°C)		1.2	
	Above 500°F (260°C)		Contact Rexnord	

^① Reversing under load can be damaging and requires special consideration. Contact Rexnord for selection assistance.

The “Start-Stop” and “% loaded” parameters are intended to guide you in classifying the severity of loading for your conveyor. If these two parameters fall into different categories (ex. start-stop less than 5/Day, % loaded at a time 5-20%) use the more severe classification (moderate).

Design and Selection

Conveyor Chain Selection Procedures – (Cont'd.)

Step 4. Make Tentative Chain Selection

To aid in making the selection, consider the following:

- a. The wear life and relative cost of each type.
- b. Short conveyor centers and high chain speeds produce rapid joint wear and chain elongation. These conditions suggest a chain with a high (A or B) wear rating.
- c. Heavy loads produce rapid sliding and rolling wear. These conditions suggest a chain with a high (A or B) sliding or rolling wear rating.
- d. Conveyors operating in highly abrasive surroundings require hard bearing surfaces. This condition would suggest a steel chain.
- e. Mildly abrasive or moderately corrosive conditions may indicate that a cast chain is the economical choice.
- f. Corrosive atmospheres reduce the fatigue strength of component parts. In this case, chain with armor cased pins are recommended.
- g. The chain pitch may be dictated by the required spacing of attachment links. A longer pitch is more economical while a shorter pitch requires less room for sprockets. In many cases a 4" to 6" pitch chain is considered a good compromise.
- h. The selection procedure outlined is applicable only if temperatures of the chain will remain within -40°F and +350°F. Special lubricants may be needed above 250°F. If these temperature limits will be exceeded, contact your Rexnord representative.

Additional factors such as sprocket availability and price, chain delivery lead time and chain price should also be considered in making the final choice.

In making the final selection reliability should be a primary consideration. Cast chains, in general, do a good job in sliding applications and have excellent corrosion resistance. However, in critical applications where overloads may be encountered, Engineered Steel and Welded Steel chains will usually provide longer and more dependable service. It is recommended, therefore, that the final selection be made from the listings of Engineered Steel and Welded Steel chains. Refer to the detail listings for the type of chain selected and select a specific chain that has a working load at least equal to the design working load and meets the pitch and space requirements.

REXNORD DOES NOT RECOMMEND CAST, CAST COMBINATION NOR WELDED STEEL CHAINS FOR ELEVATOR SERVICE.

Step 5. Make Tentative Selection of Attachment Links

Refer to the section on attachments. On the basis of the information here and on the basis of the chain selected, tentatively select the desired attachment links.

Step 6. Verify Chain Selection and Re-Check Design Working Load

Recalculate total chain pull (Pm) and design working load using the exact chain and attachment weight as given in the listings to verify that the selected chain will meet the requirements.

Selection Procedure for Double Flex Chains

This procedure is the same as that for standard chains except that the "Chain Pull" as determined must be modified. The modification is necessary because the chain is flexing around curves and additional tension is developed because of the friction between the sides of the chain and curves. The chain pull must be calculated on a cumulative basis, with the "Turn Factor" for each curve taken into account. Contact Rexnord for assistance in applying the proper "Turn Factor" for your conveyor.

Design and Selection

Conveyor Chain Selection

A horizontal scraper flight conveyor has been tentatively designed to handle Bituminous coals, and will feed an incinerator from a coal storage hopper. The coal is to be conveyed in an existing trough which is approximately 100 feet long and has a cross section as shown in the sketch below.

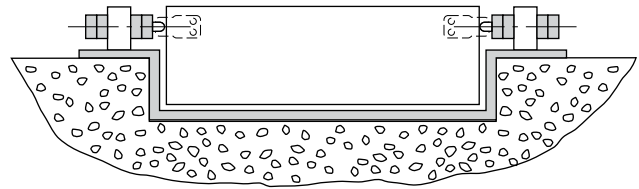
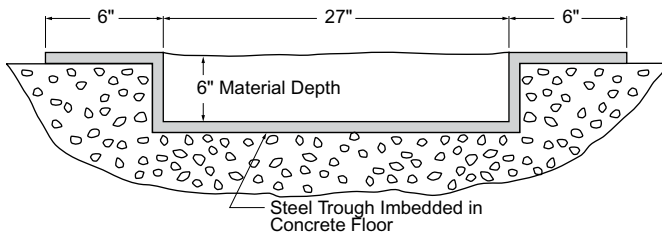

The unit becomes a scraper flight conveyor, similar to that indicated as a basic type of conveyor.

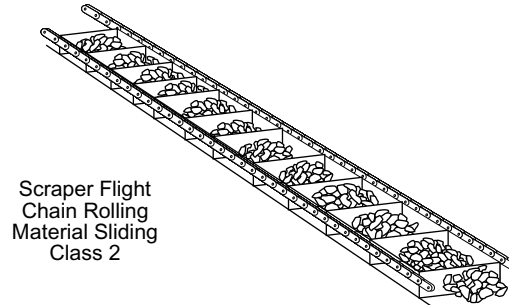

Conveyor Data

Material Handled: *Bituminous Coal*
 (1/2" maximum lump size)
 Material Density: *50 Lbs. per cubic foot*
 Conveyor Centers: *100 Feet*
 Conveyor Capacity: *170 Tons per hour*
 Conveyor Speed: *100 Feet per minute*

Other Considerations

1. Approximately 100 steel plates (1/4" x 10" x 27"; Weight 10 Lbs.) are left over from another project, complete with attachment wings. It is desired to use these as flights if possible. Attachment wings are available to suit chain.
2. No space restrictions.
3. Conveyor to operate 16 hours per day/5 days per week.
4. Drive will be selected to suit conveyor.

Select Suitable Chain

Step 1. Determine Conveyor Class

In the basic considerations section of this procedure, it was pointed out that a conveyor using a chain that rolled would result in smoother operation. Since a rolling chain also has less friction, smaller drive units could be used, at lower operating costs. Therefore, tentatively pick a chain with rollers to run on the existing trough. Also tentatively figure on using the available 10" x 27" steel flights and attachment wings. The basic conveyor cross section might become a two-chain conveyor with scraper flights connected between the chains as shown in the following sketch.

Step 2. Estimate Total Chain Pull

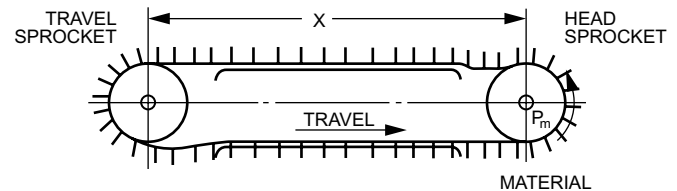

$$P_m = X \left(2f_1W + f_2M + \frac{h^2}{c} \right) + MY$$

Where:

- P_m** = Maximum chain pull (Lbs.)
- X** = Conveyor centers (100 Ft.)
- f₁** = Coefficient of friction – chain rolling on runway
- f₁** = $f_r \frac{d_a}{d_r}$ (See Table, page 123)
- f₁** = 0.20 (This factor will range from 0.10 to 0.20, depending upon the chain roller-bushing proportions. Since the chain pull is only being estimated at this point, use the highest range 0.20 in the first calculation.)
- M** = Weight of material handled per foot of conveyor
- M** = $\frac{TPH \times 33.3}{S} = \frac{170 \times 33.3}{100} = 56.6$ Lbs./Ft.
- W** = Weight per foot of moving conveyor parts
- S** = Conveyor speed (feet/minute)

Design and Selection

Design And Selection Conveyor Chain Selection Procedures – (Cont'd.)

Since the weight of the chain and attachment links has not yet been determined, use the empirical factor given on page 107 to establish chain weight.

$$W = .0015 \times 56.6 \text{ Lbs./Ft.} \times 100 \text{ Ft.} = 8.49 \text{ Lbs./Ft.}$$

Add to this the weight of the flights.

(There are approximately 100 flights available; assume a flight spacing of every 2 feet)

$$10 \text{ Lbs./ Flight} \times 1 \text{ Flight/2 Ft.} = 5 \text{ Lbs./Ft.}$$

$$W = 8.49 \text{ Lbs./Ft.} + 5 \text{ Lbs./Ft.} = 13.49 \text{ Lbs./Ft.}$$

f_2 = Coefficient of friction of material

f_2 = 0.50 (Material friction factor table, page 107)

h = Height of material (see sketch of trough)

h = 6 inches

c = Trough side friction factor

c = 21 (Material friction factor table, page 107)

y = Vertical rise = 0 (Horizontal Conveyor)

Substitute Values in Formula:

$$P_m = X \left(2f_1W + f_2M + \frac{h_2}{c} \right) + MY$$

$$= 100 \left[2 (.20)(13.49) + .50 (56.6) + \frac{62}{21} \right] + 56.6 \times 0$$

$$= 100 (5.4 + 28.3 + 1.7)$$

$$P_m = 3540 \text{ Lbs.}$$

Step 3. Determine Design Working Load

$$\text{Design W.L.} = P_m \times \text{Service Factor} \times \frac{\text{Speed Factor} \times 1.2}{\text{No. of Strands}}$$

$$= 3540 \times 1.2 \times 1.0 \times \frac{1.2}{2}$$

$$= 2545 \text{ Lbs.}$$

The Service Factor was picked from the table on page 108 for uniform loading since the conveyor is being fed from a hopper. A factor of 1.2 was selected because the conveyor will be in operation for more than 10 hours per day.

The speed factor was picked for a 12 tooth sprocket, although final sprocket selection has not been made.

Step 4. Make Tentative Chain Selection

Refer to the chain selection chart and note that an engineered steel roller type chain is recommended for a Class 2 Conveyor.

Refer to pages 10-15 of the chain listing section and note that these chains all have rollers. For the conveyor arrangement tentatively selected, a Style "R" chain, whose rollers are larger than the sidebars, should be used. As indicated in the selection procedure, Step 4-g. (Page 109), a 4- to 6-inch pitch chain is good first choice. Also, from the calculation of Design Working Load, a chain having a working load rating of 2548 pounds or greater will be required.

Checking the chain listings, you will note a number of Style "R" chains in the desired pitch range. SR196 would be selected as the chain that most closely matches the desired working load. Chains such as 2188 and 1604 have working loads substantially higher and would not be economical choices. SR196 would be the tentative selection.

Step 5. Make Tentative Selection of Attachment Links

From the basic conveyor arrangement decided upon, an attachment lug which projects on one side of the chain only is required. Also, it is desired to select an attachment link to which the available flight wings can be adapted, if possible. This suggests a single - attachment lug such as the "A" attachment. The A1 (single hole) attachment is available for the SR196 chain. Make this the tentative selection.

Step 6. Verify Chain Selection & Recheck Design

Working Load

The exact chain and attachment link weight per ft. can now be used to calculate the Design Working Load. Also, the chain roller and bushing diameters can be used to determine the chain friction factor (f_1).

Chain Weight

$$\text{SR196 Plain Chain} = 5.0 \text{ Lbs./Ft.}$$

$$\text{SR196 A1 Attachment Link} = 6.6 \text{ Lbs./Ft.}$$

The weight per foot for the attachment link is based on a link interspersed every pitch. For the conveyor arrangement to be used, an attachment link will be required every 2 feet, or every 4th pitch (6 inch pitch chain).

$$3 \text{ plain links at } 5.0 \text{ Lbs./Ft.} = 15.0 \text{ Lbs.}$$

$$1 \text{ Attachment link at } 6.6 \text{ Lbs./Ft.} = \underline{6.6 \text{ Lbs.}}$$

$$21.6 \text{ Lbs.}$$

$$21.6 \div 4 = 5.4 \text{ Lbs./Ft.}$$

$$\text{SR196 A1 every 4th link} = 5.4 \text{ Lbs./Ft.}$$

$$2 \text{ strands of chain} \times 5.4 \text{ Lbs./Ft.} = 10.8 \text{ Lbs./Ft.}$$

$$\text{Flight Weight} = \underline{5.0 \text{ Lbs./Ft.}}$$

$$15.8 \text{ Lbs./Ft.}$$

15.8 Lbs./Ft. = W = Total weight of moving conveyor parts.

Design and Selection

Chain Friction Factors

$$f_1 = f_r \frac{d_a}{d_r}$$

$f_r = 0.4$ (from table, page 123 for steel roller)

$d_a =$ Bushing diameter ($\frac{5}{8}$ " from chain listing, page 11)

$d_r =$ Roller O.D. (2" from chain listing, page 11)

$$f_1 = \left[\frac{0.4 (5/8)}{2} \right]$$

$$f_1 = 0.125$$

Use the final values of chain weight (W) and chain factor (f_1) in the chain pull formula. Use the same values for all other factors as in Step 2.

$$P_m = X (2f_1W + f_2M + \frac{h^2}{C}) + MY$$

$$= 100 \left[(2 \times .125 \times 15.8) + (.50 \times 56.6) + \frac{.6^2}{21} \right] + (56.6 \times 0)$$

$$= 100 [(3.95) + (28.3) + (1.7)]$$

$$P_m = 3395 \text{ Lbs. total conveyor chain pull}$$

$$\text{Design Working Load} = P_m \times \text{Service Factor} \times \text{Speed Factor} \times \frac{1.2}{\text{No. of Strands}}$$

$$\text{Design W.L.} = 3395 \times 1.2 \times 1.0 \times \frac{1.2}{2}$$

$$= 2444 \text{ Lbs. chain pull per strand}$$

Since the final design working load of 2444 pounds does not exceed the maximum recommended working load of 2600 as given in the chain specifications (pages 11), the SR196 chain selection is acceptable.

Elevator Chain Pull Calculation Procedure

Bucket Elevator Formulas

To Determine Chain Pull (P_m):

$$P_m = 0.5 P_t + MKD + Y (M + W)$$

Knowing the chain pull, determine the design working load and select chain service and speed factors found on page 110.

To Determine Horsepower (HP):

$$HP = \frac{1.15 (S) (MDK + MY)}{33000}$$

Where:

M = Weight of material handled per foot of elevator (lb./ft.)

M = $\frac{\text{Material Density (Lb./Ft.}^3) \times \text{Bucket Capacity (Ft}^3)}{\text{Bucket Spacing (Ft.)}}$

W = Weight of chain and buckets per foot of elevator (lbs./ft.)

$$W = \frac{\left(\frac{\text{Attach. Spacing}}{\text{in Pitches} - 1} \right) \times \left(\frac{\text{Wt. of plain chain}}{\text{(lbs./ft.)}} \right) + \left(\frac{\text{Wt. of attach. chain}}{\text{(lbs./ft.)}} \right)}{\text{attachment spacing in pitches}} + \frac{\text{Wt. of a bucket (lbs.)}}{\text{bucket spacing (ft.)}}$$

$P_t =$ Take Up Force (Lbs.)

$P_1 = 1/2$ of $P_t + WY$

D = Footshaft sprocket pitch diameter (feet)

K = Digging factor (10 for centrifugal, 6 for continuous)

S = Elevator speed (feet/minute)

Y = Elevator center distance (feet)

$$\text{TPH} = \text{Tons/Hour} = \frac{.75 (S) (M)}{33.3}$$

$$\text{CFH} = \frac{\text{TPH} \times (2000)}{\text{Material Density (lbs./ft.}^3)}$$

112 (5050)

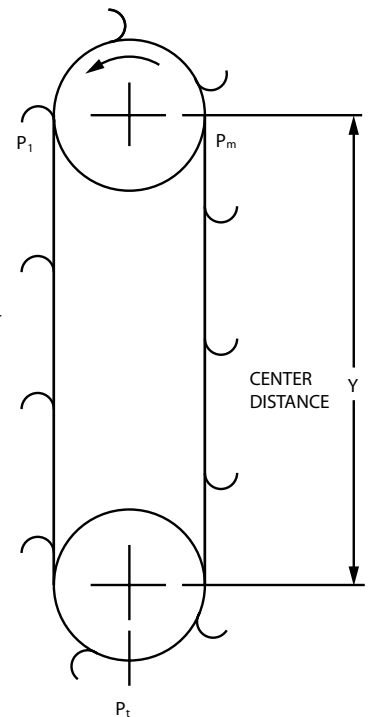

Design and Selection

Applications Beyond Scope Of Catalog Selection Procedures

Data Required for Selection

The selection procedures in this catalog were intended to cover the majority of conveyor, elevator and drive applications. However, some installations involve conditions or applications which require special

consideration in the selection process. The items listed below will aid in obtaining selection assistance. The items on this page are basic considerations which are necessary, if known, to insure selection of components best suited to the application.

General Information

1. Answer Required by (date): _____
2. Product: Chain Sprockets Other
3. Application: New Installation Replacement Component
4. Equipment Operating Time ___ Hours/Day; ___ Days/Week

Drives

1. Horsepower: Maximum ___; Percent of operating time at or above 75% Maximum Horsepower _____
2. RPM Driver _____ Driven _____; Ratio _____ Permissible Variation + _____
3. Center Distance _____
 Fixed Adjustable Permissible Variation ± _____
4. Layout: Please provide sketch. Show Centers, Driver, Direction of Rotation and Relation to Horizontal.

Conveyor and Elevator Components

1. Type: Elevator Bulk Material Conveyor Unit Handling Conveyor
2. Chain Speed: _____ Feet/Minute
3. Material Handled:

(a) If Bulk:

Characteristics: Dry Wet Sticky
 Lump Size: _____ Inches (Maximum)
 Quantity: _____ Tons/Hour;
 _____ Cubic Feet/Hour
 Density: _____ Lbs./Cubic Foot
 If material density is not known, refer to material properties table on pages 124-125.

(b) If Units:

Quantity: _____ Units/Hour
 Size: _____ x _____ x _____

Spacing: Random Regular

Weight: _____ Lbs. (each) _____ Lbs. (per foot of conveyor)
 Total weight on conveyor at one time: _____ Lbs. (Max.)

4. Loading (in Cubic Feet/Hour or Units/Hour):
 Normal _____ Peak _____ Percent of Time at Peak _____
5. Layout: Sketch showing centers, inclines, distance between chains, special attachments.

General

1. Desired Equipment Life: _____ Hours/Years
2. Environment
 (a) Temperature: Surrounding _____ °F
 Component _____ °F
 If Cycling, Time at Temperature _____
 (b) Abrasion: Material _____
 Particle Size _____ Abrasiveness _____
 (Refer to tables on pages 124-125).
 (c) Corrosion: Material _____

Conveyor and Elevator

1. Sprockets (or Traction Wheels) – No. of Teeth (or Outside Diameter):
 Head _____ Tail _____
2. Shaft Size: Head _____ Tail _____
3. Chain Attachments: Type _____ Spacing _____
4. Weight of Flights or Slats _____
5. Takeup Type: Screw Gravity – Weight
6. Elevator Buckets: Style _____
 Size _____ x _____ x _____

Drives

1. Shaft Diameters: Driver _____ Driven _____
2. Application Description: _____

3. Peak Load Factor _____
 Ratio of peak tension to mean tension while maximum horsepower is being transmitted.

Maintenance Information

Connecting And Disconnecting Chain

Introduction

Chains are manufactured with connectors, either pins or rivets of various constructions depending upon the chain type, i.e., offset or straight sidebar, Roller chain, Fabricated Steel chain, Welded Steel chain, Cast chain, Combination chain, etc. The particular connector link construction dictates the proper method and direction of connector insertion or removal from chain.

The connectors can have uniform diameters, multiple stepped diameters, locking flats, various head styles, riveted ends or various pinlocks (cotters, etc.).

A pin with either a flat on the head end, or a larger stepped diameter will not pass through the smaller cotter-side sidebar hole. Likewise, the round shank of a pin with locking flats on the cotter end will not pass through the slotted cotter-side sidebar hole.

Field Repair

When repairing chains in the field, the repair should be confined to replacement of complete links or sections. Replacement of individual components (bushings, rollers, etc.) is generally not recommended. Therefore, this connect-disconnect discussion has been limited to removal and replacement of connectors.

CAUTION: Rexnord does not recommend altering or rebuilding standard press-fit chains, or sub-assemblies especially the removal of press-fit components and their replacement with others. Such alterations destroys the integrity of the press-fits of the chain assembly.

CAUTION

When Connecting or Disconnecting Chain

- Always lockout equipment power switch before removing or installing chains.
- Always USE SAFETY GLASSES to protect your eyes.
- Wear protective clothing, gloves and safety shoes.
- Support the chain to prevent uncontrolled movement of chain and parts.
- Use of pressing equipment is recommended. Tools should be in good condition and properly used.

Do not attempt to connect or disconnect chain unless you know the chain construction, including the correct direction for pin/rivet removal or insertion.

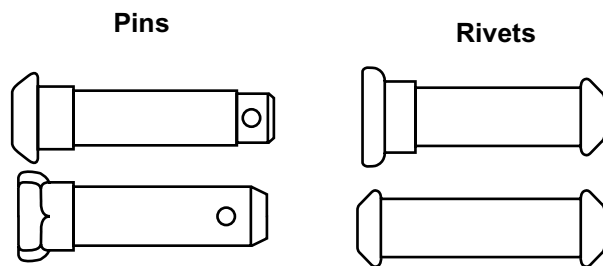

Figure 1 - Type I Connectors

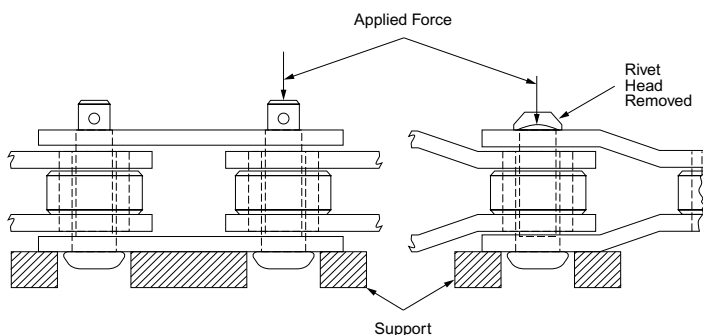

Figure 2 - Type I Connector Removal

Type I Connectors

The connector construction found in the majority of chains would be of the type shown in Fig. 1.

Head Identification

The head of a connector can usually be identified by a alpha numeric code stamped on it, or the appropriate sidebar is designated head side.

Type I Connector Removal

Type I connectors are removed by driving on the end opposite the head and supporting the link as shown in Fig.2. Refer to pages 118-119 for disassembly tools.

For Type I single diameter rivets, the method of removal suggested for Type II connectors may be preferred. (See next page).

Connection

The connector is inserted by driving on the head end of the connector and supporting the link similar to the manner shown in Fig. 2.

Maintenance Information

Connecting And Disconnecting Chain – (Cont'd.)

Connection

For connection, one sidebar is pushed onto one of the ends of the connectors and the other sidebar is pushed onto the opposite ends of the connectors. Refer to pages 118-119 for assembly tools.

Pinlocks

For cast and roller chains, the pinlocks (cotters, etc.) should be removed before pin removal. Cast chains could be damaged from the pinlock if left in during pin removal. Roller chains normally use hardened pinlocks making cutting or shearing difficult. However, for most other chains, both ends of pinlocks should be cut flush (with chisel or equivalent) with outside diameter of pin to prevent pin collapse during pin removal.

Riveted Ends

For chains of riveted construction, the riveted end should be ground flush with the sidebar before connector removal.

Loose Chain

When disconnecting and connecting loose chain, the chain should always be solidly supported against the floor, or on a bench. When employing method of Fig. 2, enough space should be provided below the end (at least twice the sidebar thickness) to allow the connector end to pass through the sidebar.

Type II Connectors

Connectors of Type II construction shown in (Fig. 3) are typically found in hollow rivet, draw bench, double flex and S-Series chains.

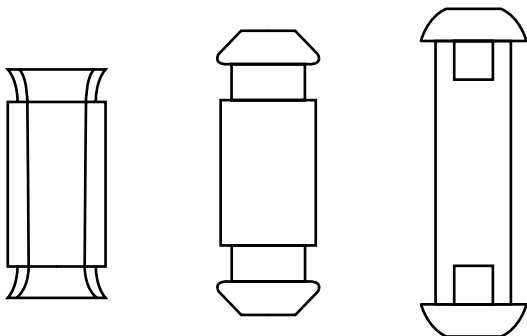

Figure 3 - Type II Connectors

Removal

Type II connectors are moved in the method shown in Fig. 4. They are removed by supporting the top sidebar and pushing the ends of the connectors free of the sidebar. An alternate method is to wedge or pry the sidebars free of the connectors.

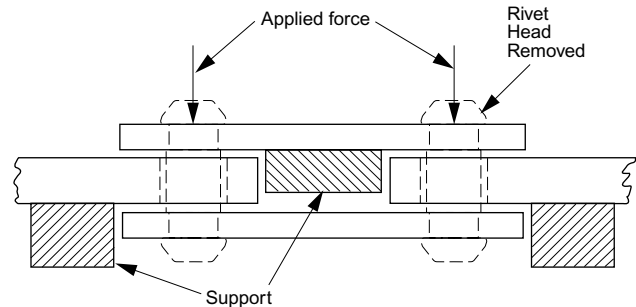

Figure 3 - Type II Connectors

To Disconnect Chains on Sprockets

1. Decrease chain tension by loosening, take-ups, etc.
2. Restrain sprockets from rotating and secure chain on both sides of disassembly point.
3. Apply penetrating oil around connectors.
4. Remove where chain wraps over the sprockets. Support against removal force with heavy bar or tubing held against opposite side of the chain and sprocket.
5. Grind riveted end (if present) of connector flush with the sidebar.
6. Remove pinlocks or cut ends flush with outside diameter of pin.
7. Use press equipment to remove connectors, e.g., hydraulic press or jack, or arbor press.

IMPORTANT SAFETY INSTRUCTIONS

- Follow safety guidelines on preceding Caution Tag.
- Don't heat or cut chain with a torch unless absolutely necessary. Any links or pins heated by such a process should be replaced during reassembly.

To Connect Chains on Sprockets

1. When connecting the strand, use the sprocket for rigid support. Support against assembly force with heavy bar or tubing held against opposite side of chain and sprocket.
2. Grease or oil the connector before replacing it.
3. Check connectors to assure proper positioning of flats or cotter holes before assembly.
4. Use press equipment to insert connectors, e.g., hydraulic press or jack or arbor press.
5. Check to see that assembled joint(s) flex freely. If not, a light blow exerted on opposite end of connector (s) should free joint(s).

IMPORTANT SAFETY INSTRUCTIONS

- Follow safety guidelines on preceding Caution Tag.
- Don't grind the circumference of the connector of the sidebar hole to ease insertion of the connector.

Maintenance Information

Drive Chains

The following suggestions are practical methods of increasing chain and sprocket life. The more of them that are followed, the longer the chain and sprocket life will be.

Lubrication

Lubrication is essential for maximum chain and sprocket life. Drive chains can and should be lubricated. Lubrication effectiveness will vary with the amount of lubricant used and frequency of application. Ideally, a lubricant film should constantly be maintained between working parts.

Chain Operation

If possible, manually lubricate the chain once a week when the chain is not under load. It is important to get the lubrication between the pin and the bushing and between the roller and the bushing. The chain is under the least load after it exits from the driver sprocket. This area will contain a catenary sag and this is the area to which manual lubrication should be applied. Pour or brush on a copious amount of oil in a continuous manner. Allow the chain to travel two complete cycles.

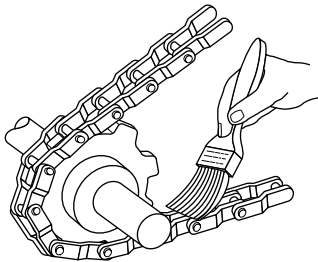

Manual Lubrication

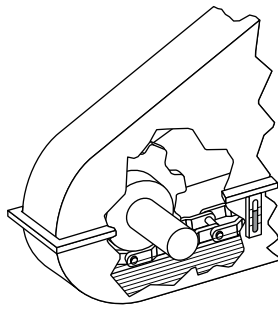

Oil Bath Lubrication

Chains operating at relatively high speeds should be completely enclosed in an oil case. The lower strand of the chain should just dip into the oil when the chain is running. Maintain the proper oil level. Excess oil causes churning and heat.

Type of Lubricant

Oil is recommended as a lubricant using the highest viscosity that will flow at the prevailing temperature:

Temperature (F)	Lubricant
Below 40	SAE 30
40-100	SAE 40
Above 100	SAE 50

Sprockets

Worn or improperly designed sprockets are one of the main causes for premature chain life or chain failure. Here are a few hints on how to get the most out of sprockets.

New Sprockets

1. When receiving new sprockets check to see if the sprockets are in pitch by wrapping the chain around sprocket and coupling.
2. Make a "Painted Pattern" by holding a piece of wood behind the new sprocket tooth and spray paint the tooth outline onto the wood. As the sprocket wears, a check on what the original shape was and how much wear has taken place can be made by putting the painted pattern behind the tooth.

Tooth Wear

On single direction drives only one side of the tooth wears. Reverse the sprocket on the shaft and put the unworn tooth face to work.

Chain and Sprocket Interaction

Closely inspect the chain and sprocket interaction to insure a smooth and noiseless operation. The chain should easily enter and exit the sprocket without a hitch.

Chain Elongation

Wear on the pin outside diameter and bushing inside diameter causes chain elongation. Once the chain has elongated or worn past acceptable limits, jumping of sprocket teeth and/or improper chain-sprocket interaction can be expected. Typical allowable elongations are 3 to 5% of chain pitch for drive chains. After the chain has been elongated or worn past acceptable limits, it should be replaced.

How to Dimensionally Identify Chain:

First check chain for any markings.

1. Determine if sidebars have straight or offset construction.
2. Measure chain pitch.
3. Measure pin diameter.
4. Measure roller diameter & width.
5. Measure sidebar thickness & height.
6. Measure bushing length.

FOR BEST RESULTS, CLEAN CHAIN AND SPROCKET PERIODICALLY.

Maintenance Information

Conveyor Chains

Wherever possible, lubrication of chain is always recommended to assure maximum chain life and optimum conveyor operation. The reduction in friction and increase in wear life usually justifies the additional cost.

Under normal conditions, chains with rollers are selected only when proper lubrication is possible.

In some applications the presence of a lubricant cannot be tolerated, but it still may be possible to attain satisfactory service with sacrifice to chain and conveyor life.

The following are general guides:

Type of Lubricant

Oil is recommended as a lubricant. Use the same lubricants recommended for drive chains at the same temperature ranges.

Grease can be used if it is applied internally into the joint with lubrication fittings on rivets or bushings.

Method of Lubrication

Oil flow or brush type lubrication is adequate under relatively clean conditions, but they are ineffective with dirty conditions. "Flush" lubrication (flooding the chain) once per day is normally adequate in dirty environments.

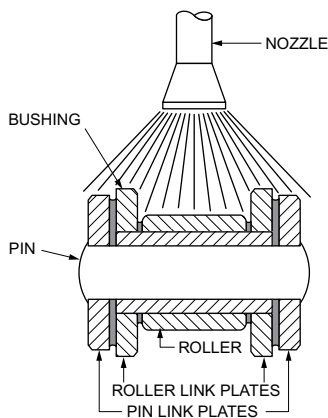

When manually lubricating, the oil should be directed between adjacent outer and inner sidebars (for the joint) and between inner sidebar and roller face (for roller-bushing lubrication). For best results, clean chain and sprocket periodically.

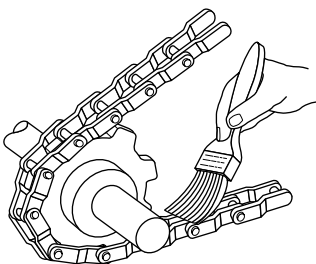

The effectiveness of any lubrication method will vary with the amount of lubricant used and the frequency of application. Ideally, a lubricant film should be maintained between working parts.

Chain and Sprocket Storage

Do not store in an "open" area where dust, dirt and water are present. **Sprockets**, especially the tooth face and the inside of the bore, should be painted with a heavy lubricant to prevent corrosion. Most manufacturers pre-lubricate chain when it is shipped from the manufacturing plant. If you do not intend to use the chain when you receive it and it will be stored for a period of time, the chain should be lubricated periodically. If possible, store chain in a fifty gallon drum or other container filled with "Used Drain Oil." This will provide excellent protection for the chain as well as good break-in lubrication for the chain when it is finally used. This pre-lubrication will allow the chain and sprockets to "break in" or "shine-up" properly. If a chain is installed into the application completely dry this will reduce its overall life.

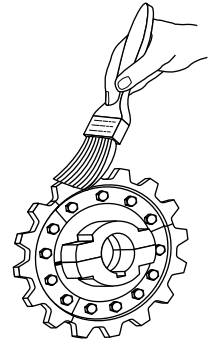

If it is impossible to store in "lubricated" environment, then oil the chain after installation but before any load is applied. Run the chain for 24 hours without any load to allow for good break-in. It is also a good idea to lubricate drag chain conveyor ways with moly-disulfide so that a proper surface will develop between the chain ways and the chain.

Chain Installation

Do not grind the chain pins or the holes in the sidebar in order to assemble the chain. Chain reliability is based upon a good press fit of the pins into the sidebars. If you reduce that press fit you can reduce chain life. Lubricate the pin when installing it, as this eases assembly.

Chains on Idle Equipment

If the equipment is to be idle for any length of time, clean the chain and sprockets by brushing or swabbing if possible, or with a steam hose. Then cover the chain and sprockets with a light oil.

Chain Operation

If possible, manually lubricate the chain once a week when the chain is not under load. Try to flow the oil between the pin and bushing and between the roller and the bushing. Usually the chain is under the least load after it exits from the driver sprocket. This area should contain a catenary sag, and this is the area where manual lubrication should be applied. Flow or brush on a predetermined amount of oil in the shortest amount of time possible, but still allowing the chain to travel two complete cycles.

Maintenance Information

Chain Assembly/Disassembly Tools – Drivemaster

Assemble and disassemble Rexnord and Link-Belt Drive Chains quickly and safely with these portable tools. Keep the advantages of interference fit, thereby maintaining optimum chain fatigue life. The design of these tools will facilitate assembly or disassembly of catalog listed drive chains, through 7-inch pitch.

Features	Benefits
Easy-to-use	Reduces down-time. Eliminates cumbersome assembly/disassembly methods.
Maintains Press-Fits	No hammering or back-up required. Insures optimum chain fatigue life.

Drivemaster I*			
No. 3	RO635	RX1207	R3112
RX238	R778	1240	B3113
R362	1030	1244	3120CM
R432	R1033	RX1245	3125
R506	R1035	R1248	3140CM
R514	R1037	X1343	3160CM
A520	A1204	X1345	3180
B578	RO1205	AX1568	
R588			
Drivemaster II*			
RO1306	RX9506	X1311	X1365
ROS1306	1301	X1307	A1309

*Contact Rexnord for non-listed chains. Rexnord drive chains are listed. To interchange Link-Belt and Rexnord chain numbers see page 65.

To Disassemble Chain:

1. Read And Follow All Precautions Listed On Chain Tool.
2. Be sure to use the correct chain adapters for the chain being Disassembled
3. Remove dust cover from cylinder and connect pump hose to cylinder by finger tightening.
4. Be sure cylinder is completely collapsed. If not, open relief valve (counterclockwise) and push ram in.
5. Close relief valve on hand pump (clockwise).
6. Remove cotters or pinlocks. If this is not possible, tool will shear off without damage to chain or tool, but repinning may be difficult due to the sheared cotter or pinlock that is pressed in the hole. Cover cotter with rag before shearing.
7. Place chain link to be disassembled securely in saddle with cotter end of pin facing toward ram.
8. For stability it may be helpful to secure pump to steel plate or flat board.
9. Apply pressure by pumping hand pump. Be sure ram is squarely on end of pin and that head end will clear discharge slot on opposite end.
10. After pin is free of sidebars remove pin from chain link by pulling through discharge slot.
11. To remove chain from unit, open relief valve (counterclockwise) and close cylinder by pushing ram in.
12. Replace dust cover on cylinder.

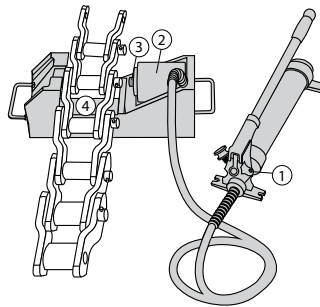

Part Identification

- 1-Relief Valve
- 2-Cylinder
- 3-Ram
- 4-Saddle and Support Plate

To Assemble Chain:

1. Read And Follow All Precautions Listed On Chain Tool.
2. Be sure to use the correct chain adapters for the chain being assembled. Adapters are labeled with chain number.
3. Remove dust cover from cylinder and connect pump hose to cylinder by finger tightening.
4. Place pin in chain joint to be assembled by hand as far as possible. Line up pin locking flats where applicable; tap pin with hammer to "Snug-Up", (improper alignment could shear hole).
5. Close relief valve on hand pump (clockwise).
6. Place chain joint securely in saddle (4) with pin head facing toward ram.
7. For stability, it may be helpful to secure pump to steel plate or flat board.
8. Apply pressure by pumping hand pump. Be sure that ram is squarely on pin head.
9. After pin head is flush with sidebars open relief valve (counterclockwise) and close cylinder by pushing ram down. Remove chain.
10. If chain does not flex freely, hit pin cotter end hard with hammer to establish clearance.
11. Replace dust cover on cylinder.

PRECAUTIONS

1. Always wear safety glasses.
2. Take necessary precautions to secure chain.
3. Be sure to use correct chain adapters.
4. This tool is not to be used to manufacture chain.
5. Do not hammer on this unit when it is under pressure, or at any other time.
6. Always use the hand pump supplied with this unit. Drivemaster will not be supplied without hand pump.
7. When not in use, be sure dust covers are replaced.
8. Use this tool only with the chains recommended by Rexnord.

Maintenance Information

Chain Assembly/Disassembly Tools – Linkmaster

Keep the advantages of interference fit by eliminating pin grinding or heating of sidebars which decreases the fatigue strength of the chain, resulting in premature chain failure.

The design of this tool will facilitate assembly or disassembly of larger straight sidebar chains including the Rexnord ER800 and ER900 Series and Link-Belt SBX800 and SBX2800 Series elevator chains. The outstanding “mobility” of this tool allows usage “in the elevator” as well as on the floor. Contact Rexnord for chains not mentioned above.

Elevator Chains – Rexnord ER800 and ER900 Series – Link-Belt SBX800 and SBX2800 Series

For detailed dimensions of these chains, see “Numerical Chain and Sprocket” index for page location.

To Disassemble Chain:

Tool shown in chain disassembly position. To reassemble chain, reverse tool so ram (4) contacts pin head.

1. **Read And Follow All Precautions Listed On Chain Tool.**
2. Be sure cylinder is completely collapsed.
3. Close relief valve on hand pump.
4. Remove cotters, if possible. Otherwise, the Linkmaster will shear them off without damage to the chain or itself.
5. Apply pressure by pumping hand pump. Be sure ram is squarely on end of pin and that the head end clears the recessed contact plate on the opposite end (See View “B”). Check this periodically until pin is free of sidebars. Failing to do this could damage pump.
6. To remove unit from chain, open relief valve and close cylinder by pushing force arms together. Newer models have automatic spring return cylinders.
7. Replace the dust cover on the cylinder

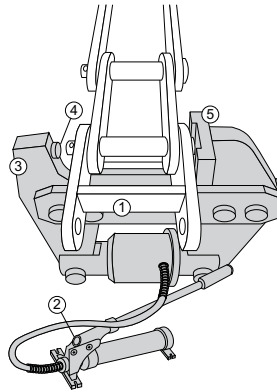

Part Identification

- 1-Spacer Gage (Rectangular)
- 2-Relief Valve
- 3-Force Arm
- 4-Ram
- 5-Support Plate

To Assemble Chain:

1. **Read And Follow All Precautions Listed On Chain Tool.**
2. Insert pin in joint as far as possible. A light coat of oil may be applied to the pin O.D. and sidebar holes to facilitate assembly. Tap the pin lightly with a hammer to provide a snug fit as improper alignment could damage the holes.
3. Place the Linkmaster over the chain joint, and apply pressure squarely on the pin head. Make sure the cotter end clears the recessed contact plate on the opposite end (See View “A”).
4. Apply pressure until the pin head is almost flush with the sidebar. Check the Linkmaster periodically so it doesn't slip off of the pin.
5. Open the relief valve to reduce pressure.
6. Insert the cotter.
7. Apply a firm hammer blow on the end of the pin to loosen the joint so it may flex freely.
8. Insert spacer gage between the inside surfaces of the outside sidebars to verify the proper width between them has been maintained.
9. Replace the dust cover on the cylinder.

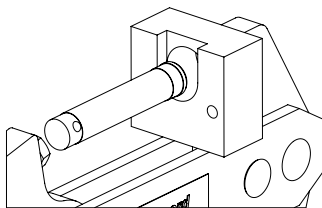

VIEW B

Tool shown positioned to disassemble ER864 chain. Be sure pin head will clear support plate as shown in View “B”.

VIEW A

Rexnord's Linkmaster tool shown positioned to assemble ER864 chain. Apply pressure to pin head only until it contacts sidebar. Be sure pin end will clear support plates shown in View “A”.

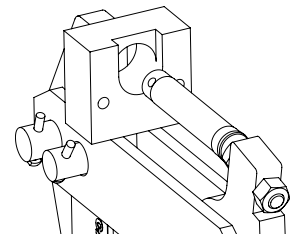

PRECAUTIONS

1. Always wear safety glasses.
2. Take necessary precautions to secure chain.
3. Be sure to use correct chain adapters.
4. This tool is not to be used to manufacture chain.
5. Do not hammer on this unit when it is under pressure, or at any other time.
6. Always use the hand pump supplied with this unit. Linkmaster will not be supplied without hand pump.
7. When not in use, be sure dust covers are replaced.
8. Use this tool only with the chains recommended by Rexnord.

Engineering Data

Sprocket Pitch Diameters

The following table (based on chordal pitch) shows the correct sprocket pitch diameters for all types of chains having a taut, uniform pitch of one inch. Sprocket pitch diameters for other uniform chain pitches are directly proportional to the chain pitch. To determine sprocket pitch diameters for any other chain pitch, multiply the tabular diameter by the chain pitch used.

Dimensions are in inches.

No. or Teeth "N"	Pitch Diameter	No. or Teeth "N"	Pitch Diameter	No. or Teeth "N"	Pitch Diameter	No. or Teeth "N"	Pitch Diameter
4	1.4142	28	8.9314	52	16.5621	76	24.1985
5	1.7013	29	9.2491	53	16.8802	77	24.5166
6	2.0000	30	9.5668	54	17.1984	78	24.8349
7	2.3048	31	9.8844	55	17.5166	79	25.1532
8	2.6131	32	10.2023	56	17.8349	80	25.4713
9	2.9238	33	10.5201	57	18.1527	81	25.7896
10	3.2361	34	10.8379	58	18.4710	82	26.1079
11	3.5494	35	11.1558	59	18.7891	83	26.4261
12	3.8637	36	11.4737	60	19.1073	84	26.7442
13	4.1786	37	11.7916	61	19.4254	85	27.0626
14	4.4940	38	12.1096	62	19.7437	86	27.3807
15	4.8097	39	12.4276	63	20.0619	87	27.6989
16	5.1258	40	12.7455	64	20.3800	88	28.0170
17	5.4422	41	13.0635	65	20.6981	89	28.3355
18	5.7588	42	13.3815	66	21.0136	90	28.6537
19	6.0755	43	13.6995	67	21.3347	91	28.9724
20	6.3925	44	14.0175	68	21.6528	92	29.2901
21	6.7095	45	14.3356	69	21.9710	93	29.6082
22	7.0276	46	14.6536	70	22.2890	94	29.9268
23	7.3439	47	14.9717	71	22.6073	95	30.2447
24	7.6613	48	15.2898	72	22.9256	96	30.5628
25	7.9787	49	15.6079	73	23.2438	97	30.8811
26	8.2962	50	15.9269	74	23.5620	98	31.1994
27	8.6138	51	16.2441	75	23.8802	99	31.5177
						100	31.8362

Conversion Table

Fraction	Decimal	Millimeters	Fraction	Decimal	Millimeters
$\frac{1}{64}$.015625	.3969	$\frac{33}{64}$.515625	13.0969
$\frac{1}{32}$.03125	.7938	$\frac{17}{32}$.53125	13.4938
$\frac{3}{64}$.046875	1.1906	$\frac{35}{64}$.546875	13.8907
$\frac{1}{64}$.0625	1.5875	$\frac{9}{16}$.5625	14.2876
$\frac{5}{64}$.078125	1.9844	$\frac{37}{64}$.578125	14.6844
$\frac{3}{32}$.09375	2.3813	$\frac{19}{32}$.59375	15.0813
$\frac{7}{64}$.109375	2.7781	$\frac{39}{64}$.609375	15.4782
$\frac{1}{8}$.125	3.1750	$\frac{5}{8}$.625	15.8751
$\frac{9}{64}$.140625	3.5719	$\frac{41}{64}$.640625	16.2719
$\frac{5}{32}$.15625	3.9688	$\frac{21}{32}$.65625	16.6688
$\frac{11}{64}$.171875	4.3656	$\frac{43}{64}$.671875	17.0657
$\frac{3}{16}$.1875	4.7625	$\frac{11}{16}$.6875	17.4626
$\frac{13}{64}$.203125	5.1594	$\frac{45}{64}$.703125	17.8594
$\frac{7}{32}$.21875	5.5563	$\frac{23}{32}$.71875	18.2563
$\frac{15}{64}$.234375	5.9531	$\frac{47}{64}$.734375	18.6532
$\frac{1}{4}$.250	6.3500	$\frac{3}{4}$.750	19.0501
$\frac{17}{64}$.265625	6.7469	$\frac{49}{64}$.765625	19.4470
$\frac{9}{32}$.28125	7.1438	$\frac{25}{32}$.78125	19.8438
$\frac{19}{64}$.296875	7.5406	$\frac{51}{64}$.796875	20.2407
$\frac{5}{16}$.3125	7.9375	$\frac{13}{16}$.8125	20.6376
$\frac{21}{64}$.328125	8.3344	$\frac{53}{64}$.828125	21.0345
$\frac{11}{32}$.34375	8.7313	$\frac{27}{32}$.84375	21.4313
$\frac{23}{64}$.359375	9.1282	$\frac{55}{64}$.859375	21.8282
$\frac{3}{8}$.375	9.5250	$\frac{7}{8}$.875	22.2251
$\frac{25}{64}$.390625	9.9219	$\frac{57}{64}$.890625	22.6220
$\frac{13}{32}$.40625	10.3188	$\frac{29}{32}$.90625	23.0188
$\frac{27}{64}$.421875	10.7157	$\frac{59}{64}$.921875	23.4157
$\frac{7}{16}$.4375	11.1125	$\frac{15}{16}$.9375	23.8126
$\frac{29}{64}$.453125	11.5094	$\frac{61}{64}$.953125	24.2095
$\frac{15}{32}$.46875	11.9063	$\frac{31}{32}$.96875	24.6063
$\frac{31}{64}$.484375	12.3032	$\frac{63}{64}$.984375	25.0032
$\frac{1}{2}$.500	12.7001	1	1.000	25.4001

Engineering Data

Standard Key And Setscrew Sizes

Keyseats and Keys

Drawings and formulas at right illustrate how the depth and width of standard keyseats in shafts and hubs are determined. Refer to explanation of symbols.

Symbols:

C = Allowance or clearance for key
(normally .005" for parallel keys).

D = Nominal shaft or bore diameter, inches

H = Nominal key height, inches

W = Nominal key width, inches

Y = Chordal height, inches

$$T = \sqrt{\frac{D^2 - D^2 - W^2}{2}}$$

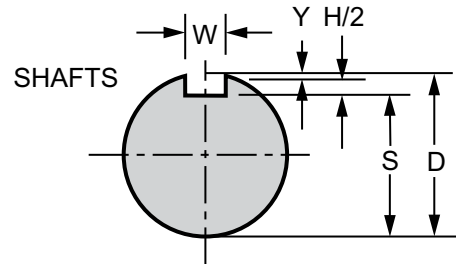

$$S = D - Y - \frac{H}{2}$$

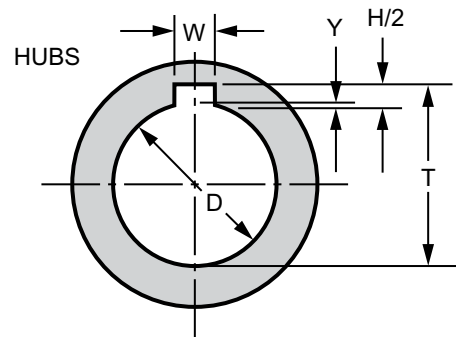

$$T = D - Y + \frac{H}{2} + C$$

Standard Keyway And Setscrew Sizes

Dimensions are in inches.

Shaft Diameters		Key W x H/2	Set Screw	Shaft Diameters		Key W x H/2	Set Screw	Shaft Diameters		Key W x H/2	Set Screw	Shaft Diameters		Key W x H/2	Set Screw
Over	Thru			Over	Thru			Over	Thru			Over	Thru		
7/16	9/16	1/8 x 1/16	#10	1 3/4	2 1/4	1/2 x 1/4	1/2	4 1/2	5 1/2	1 1/4 x 5/8	7/8	11	13	3 x 1	1
9/16	7/8	3/16 x 3/32	1/4	2 1/4	2 3/4	5/8 x 5/16	1/2	5 1/2	6 1/2	1 1/2 x 3/4	1	13	15	3 1/2 x 1 1/4	1
7/8	1 1/4	1/4 x 1/8	5/16	2 3/4	3 1/4	3/4 x 3/8	5/8	6 1/2	7 1/2	1 3/4 x 3/4	1	15	18	4 x 1 1/2	1
1 1/4	1 3/8	5/16 x 5/32	3/8	3 1/4	3 3/4	7/8 x 7/16	3/4	7 1/2	9	2 x 1 3/4	1	18	22	5 x 1 3/4	1
1 3/8	1 3/4	3/8 x 3/16	3/8	3 3/4	4 1/2	1 x 1/2	3/4	9	11	2 1/2 x 7/8	1	22	26	6 x 2	1
												26	30	7 x 2 1/2	1

Minimum Shaft Center Distance

At least 120° wrap is desirable. The minimum center distance to assure 120° wrap may be found by using the following equation:

$$CDp = \frac{N - n}{3.1}$$

On ratios of less than 3:1, wrap will always be at least 120° in a two sprocket system. The minimum center distance to avoid interference between the two sprockets is:

$$\text{Min. } CDp = \frac{N + n}{6} + 1$$

Where: CDp = center distance in pitches

N = number of teeth on driven sprocket

n = number of teeth on driver sprocket

Use the larger value of CDp for your center distance.

Feet of center distance =

$$\frac{\text{Center Distance (pitches)} \times \text{Chain Pitch (Ins.)}}{12}$$

Engineering Data

Minimum Chain Length

The approximate chain length may be obtained using this formula:

$$L_p = 2CDp + \frac{N + n}{2} + K$$

Where: **L_p** = Length of chain, in Pitches
CDp = Distance between shaft centers, in Pitches
N = Number of teeth on Driven sprocket
n = Number of teeth on Driver sprocket
K = $.0258 \times \frac{(N - n)^2}{CDp}$

Feet of chain = $\frac{\text{Chain Length (pitches)} \times \text{Pitch of Chain (Ins.)}}{12}$

Power And Cycle Calculations

Horsepower
 $HP = \frac{T \text{ (RPM)}}{63000}$

$HP = \frac{P \text{ (FPM)}}{33000}$

Where: **T** = Torque (Inch-Lb.)
P = Net chain pull (lbs.)
RPM = Shaft speed (Rev./Minute)
FPM = Chain speed (Ft./Minute)

Chain Speed (In FPM)

$$FPM = \frac{RPM \text{ (no. of teeth)} \text{ (pitch in inches)}}{12}$$

Number of Cycles of Chain Operation

A cycle is defined as one complete traverse of a given link around the sprockets and back to its starting point. The number of cycles a chain has been operated can be calculated as follows:

$$\text{Total Cycles} = \frac{\text{(no. of teeth)} \text{ (RPM)} \text{ (60)} \text{ (HR)}}{\text{(no. of Pitches in Chain)}}$$

Where: **HR** = Total operating time (hours)

Catenary Tension

The tension in the chain on the slack side, caused by the catenary sag of the unsupported chain, can be calculated from the following formula:

$$T = \frac{B^2 \times W}{96 \text{ CS}} + \frac{W \times CS}{12}$$

Where: **T** = Chain tension due to catenary sag (lbs.)
B = Center Distance (inches)
W = Weight of chain (lbs./ft.)
CS = Catenary sag (inches)

Catenary tension for a chain weighing one pound per foot is shown in the accompanying table. To find the tension in a chain weighing "W" pounds per foot, multiply the listed value by "W".

Catenary Tension – Pounds

Dimensions are in inches.

Center Distance	Amount of Catenary Sag																	
	.125	.25	.375	.50	.75	1.0	2.0	3.0	4.0	5.0	6.0	7.0	8.0	9.0	10.0	12.0	14.0	16.0
10	8.3	4.2	2.8	2.1	1.5	1.1	0.7	0.6	0.6	0.6	0.7	0.7	0.8	0.9	0.9	1.1	1.2	1.4
20	33.3	16.7	11.1	8.4	5.6	4.3	2.3	1.6	1.4	1.3	1.2	1.2	1.2	1.2	1.3	1.3	1.5	1.6
30	75.0	37.5	25.0	18.8	12.6	9.5	4.9	3.4	2.7	2.3	2.1	1.9	1.8	1.8	1.8	1.8	1.8	1.9
40	133.3	66.7	44.5	33.4	22.3	16.8	8.5	5.8	4.5	3.8	3.3	3.0	2.8	2.6	2.5	2.4	2.4	2.4
50	208.3	104.2	69.5	52.1	34.8	26.1	13.2	8.9	6.8	5.6	4.8	4.3	3.9	3.6	3.4	3.2	3.0	3.0
60	300.0	150.0	100.0	75.0	50.1	37.6	18.9	12.8	9.7	7.9	6.8	5.9	5.4	4.9	4.6	4.1	3.8	3.7
70	408.3	204.2	136.1	102.1	68.1	51.1	25.7	17.3	13.1	10.6	9.0	7.9	7.0	6.4	5.9	5.3	4.8	4.5
80	533.3	266.7	177.8	133.4	89.0	66.8	33.5	22.5	17.0	13.8	11.6	10.1	9.0	8.2	7.5	6.6	5.9	5.5
90	675.0	337.5	225.0	168.8	112.6	84.5	42.4	28.4	21.4	17.3	14.6	12.6	11.2	10.1	9.3	8.0	7.2	6.6
100	833.3	416.7	277.6	208.4	139.0	104.3	52.3	35.0	26.4	21.3	17.9	15.5	13.7	12.3	11.3	9.7	8.6	7.8
110	1008.0	504.2	336.1	252.1	168.1	126.1	63.2	42.3	31.8	25.6	21.5	18.6	16.4	14.8	13.4	11.5	10.2	9.2
120	1200.0	600.0	400.0	300.0	200.1	150.1	75.2	50.3	37.8	30.4	25.5	22.0	19.4	17.4	15.8	13.5	11.9	10.7
130	1406.0	704.2	469.5	352.1	234.8	176.1	88.2	58.9	44.3	35.6	29.8	25.7	22.7	20.3	18.4	15.7	13.7	12.3
140	1633.0	816.7	544.5	408.4	272.3	204.3	102.3	68.3	51.4	41.3	34.5	29.8	26.2	23.4	21.3	18.0	15.8	14.1
150	1875.0	937.5	625.0	468.8	312.6	234.5	117.4	78.4	58.9	47.3	39.6	34.1	30.0	26.8	24.3	20.5	17.9	16.0
160	2133.0	1067.0	711.1	533.4	355.6	266.8	133.5	89.1	67.0	53.8	44.9	38.7	34.0	30.4	27.5	23.2	20.2	18.0
170	2408.0	1204.0	802.8	602.1	401.5	301.1	150.7	100.6	75.6	60.6	50.7	43.6	38.3	34.2	30.9	26.1	22.7	20.1
180	2700.0	1350.0	900.0	675.0	450.1	337.6	168.9	112.8	84.7	67.9	56.8	48.8	42.9	38.3	34.6	29.1	25.3	22.4
190	3008.0	1504.0	1003.0	752.1	501.5	376.1	188.2	125.6	94.3	75.6	63.2	54.3	47.7	42.5	38.4	32.2	28.0	24.8
200	3333.0	1667.0	1111.0	833.4	555.6	416.8	208.5	139.1	104.5	83.8	69.9	60.1	52.8	47.0	42.5	35.7	30.9	27.4

For chain weighing one pound per foot.

Engineering Data

Catenary Sag

The return strand of a chain normally has some slack. This slack results in a sag, called catenary sag, of the chain. This sag must be of the correct amount if the chain is to operate properly. If the return strand is too tight (too little catenary sag), the load and the wear on working parts will be excessive. If the return strand is too loose, vibration and unwanted chain flexure will result. A chain that is properly installed will permit flexing of the return strand by hand. This flexure, measured from a straight line, should not be less than about 3% of the horizontal center distance.

The amount of catenary sag that will be present can be calculated as follows:

$$CS = \sqrt{.375 BE}$$

- Where: CS = Catenary sag (inches)
 L = Return strand length (inches)
 B = Center distance (inches)
 E = Excess chain, L – B (inches)

Depending on the combination of chain pitch, sprocket center distance, and number of teeth in the sprockets, there will always be excess chain in the system. The catenary sag resulting from this excess chain for various sprocket center distances is given in the table below.

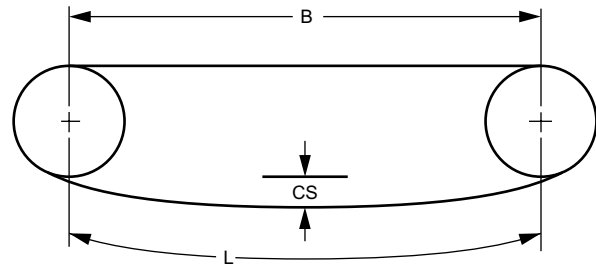

Catenary Sag

Dimensions are in inches.

Center Distance	Excess Chain																	
	.063	.125	.188	.250	.313	.375	.438	.500	.625	.750	.875	1.00	1.50	2.00	2.50	3.00	3.50	4.00
10	0.5	0.7	0.8	1.0	1.1	1.2	1.3	1.4	1.5	1.7	1.8	1.9	2.4	2.7	3.1	3.4	3.6	3.9
20	0.7	1.0	1.2	1.4	1.5	1.7	1.8	1.9	2.2	2.4	2.6	2.7	3.4	3.9	4.3	4.7	5.1	5.5
30	0.8	1.2	1.5	1.7	1.9	2.1	2.2	2.4	2.7	2.9	3.1	3.4	4.1	4.7	5.3	5.8	6.3	6.7
40	1.0	1.4	1.7	1.9	2.2	2.4	2.6	2.7	3.1	3.4	3.6	3.9	4.7	5.5	6.1	6.7	7.2	7.7
50	1.1	1.5	1.9	2.2	2.4	2.7	2.9	3.1	3.4	3.8	4.1	4.3	5.3	6.1	6.8	7.5	8.1	8.7
60	1.2	1.7	2.1	2.4	2.7	2.9	3.1	3.4	3.8	4.1	4.4	4.7	5.8	6.7	7.5	8.2	8.9	9.5
70	1.3	1.8	2.2	2.6	2.9	3.1	3.4	3.6	4.1	4.4	4.8	5.1	6.3	7.2	8.1	8.9	9.6	10.2
80	1.4	1.9	2.4	2.7	3.1	3.4	3.6	3.9	4.3	4.7	5.1	5.5	6.7	7.7	8.7	9.5	10.2	11.0
90	1.5	2.1	2.5	2.9	3.2	3.6	3.8	4.1	4.6	5.0	5.4	5.8	7.1	8.2	9.2	10.1	10.9	11.6
100	1.5	2.2	2.7	3.1	3.4	3.8	4.1	4.3	4.8	5.3	5.7	6.1	7.5	8.7	9.7	10.6	11.5	12.2
110	1.6	2.3	2.8	3.2	3.6	3.9	4.2	4.5	5.1	5.6	6.0	6.4	7.9	9.1	10.2	11.1	12.0	12.8
120	1.7	2.4	2.9	3.4	3.8	4.1	4.4	4.7	5.3	5.8	6.3	6.7	8.2	9.5	10.6	11.6	12.5	13.4
130	1.7	2.5	3.0	3.5	3.9	4.3	4.6	4.9	5.5	6.0	6.5	7.0	8.6	9.9	11.0	12.1	13.1	14.0
140	1.8	2.6	3.1	3.6	4.1	4.4	4.8	5.1	5.7	6.3	6.8	7.2	8.9	10.2	11.5	12.5	13.6	14.5
150	1.9	2.7	3.2	3.8	4.2	4.6	5.0	5.3	5.9	6.5	7.0	7.5	9.2	10.6	11.9	13.0	14.0	15.0
160	1.9	2.7	3.4	3.9	4.3	4.7	5.1	5.5	6.1	6.7	7.2	7.7	9.5	11.0	12.2	13.4	14.5	15.5
170	2.0	2.8	3.5	4.0	4.5	4.9	5.3	5.6	6.3	6.9	7.5	8.0	9.8	11.3	12.6	13.8	14.9	16.0
180	2.1	2.9	3.6	4.1	4.6	5.0	5.4	5.8	6.5	7.1	7.7	8.2	10.1	11.6	13.0	14.2	15.4	16.4
190	2.1	3.0	3.7	4.2	4.7	5.2	5.6	6.0	6.7	7.3	7.9	8.4	10.3	11.9	13.3	14.6	15.8	16.9
200	2.2	3.1	3.8	4.3	4.8	5.3	5.7	6.1	6.8	7.5	8.1	8.7	10.6	12.2	13.7	15.0	16.2	17.3

Note: Values above and to the right of the heavy stepped line represent 3% or greater sag.

Engineering Data

Weights And Conveying Characteristics Of Materials

Table (A) lists CEMA material class descriptions and corresponding codes referred to in Table (B). Table (B) lists typical values. Some materials, particularly ores, vary widely. Weight and angle of repose depend largely on the size distribution in a given material. Degree of aeration may be important factor in density of very fine material. Angle of repose may increase with the percentage of fines as well as the angularity of the particles. Fines carry most of the moisture content, which is often the controlling factor. For these reasons, the values given can only be approximate.

Table A – CEMA Material Class Description

	Material Characteristics	Code
Size	Very fine – 100 mesh and under	A
	Fine – 1/8 inch and under	B
	Granular – Under 1/2 inch	C
	Lumpy – containing lumps over 1/2 inch	D
	Irregular – string, interlocking, mats together	E
Flowability Angle of Repose	Very free flowing – angle of repose less than 20°	1
	Free flowing – angle of repose 20 degrees to 30°	2
	Average flowing – angle of repose 30° to 45°	3
	Sluggish – angle of repose 45° and over	4
Abrasive	Non-abrasive	5
	Abrasive	6
	Very abrasive	7
	Very sharp – cuts or gouges belt covers	8
Miscellaneous Characteristics (More than one may apply.)	Very dusty	L
	Aerates and develops fluid characteristics	M
	Contains explosive dust	N
	Contaminable affecting use of saleability	P
	Degradable, affecting use of saleability	Q
	Gives off harmful fumes or dust	R
	Highly corrosive	S
	Mildly corrosive	T
	Hygroscopic	U
	Interlocks or mats	V
	Oils or chemicals present – may affect rubber products	W
	Packs under pressure	X
	Very light and fluffy – may be wind swept	Y
Elevated temperature	Z	

Table B – Conveying Properties Of Materials

Material	Lbs. per Cu. Ft.	Angle of Repose	Recom'd Max. Incl.	Code	Material	Lbs. per Cu. Ft.	Angle of Repose	Recom'd Max. Incl.	Code
Alfalfa meal	17	45°	—	B46Y	Carbon black, powder	4-7	30-44°	—	*A35Y
Alum, fine	45-50	30-44°	—	B35	Carborundum, 3" and under	100	20-29°	—	D27
Alum, lumpy	50-60	30-44°	—	D35	Casein	36	30-44°	—	B35
Alumina	50-65	22°	10-12°	B27M	Cast iron chips	90-120	45°	—	C46
*Aluminum chips	7-15	45°	—	E46Y	Cement, Portland	72-99	30-44°	20-23°	A36M
Aluminum hydrate	18	34°	20-24°	C35	Cement, Portland, aerated	60-75	—	—	A16M
Aluminum oxide	70-120	29°	—	A27M	Cement, rock (see limestone)	100-110	—	—	D36
Aluminum silicate	49	30-44°	—	B35S	Cement clinker	75-95	30-40°	18-20°	D37
Aluminum sulphate	54	32°	17°	D35	Chalk, lumpy	75-85	45°	—	D46
Ammonium chloride, crystalline	45-52	30-44°	—	B36S	*Charcoal	18-25	35°	20-25°	D36Q
Ammonium nitrate	45	30-44°	—	*C36NUS	Chrome ore (chromite)	125-140	30-44°	—	D37
Ammonium sulphate, granular	45-58	44°	—	*C35TU	Cinders, blast furnace	57	35°	18-20°	*D37T
Asbestos, ore or rock	81	30-44°	—	D37R	Cinders, coal	40	35°	20°	*D37T
Asbestos, shred	20-25	45°	—	E46XY	Clay, calcined	80-100	—	—	B37
Ashes, coal, dry, 3" and under	35-40	45°	—	D46T	Clay, dry, fines	100-120	35°	20-22°	C37
Ashes, coal, wet, 3" and under	45-50	45°	—	D46T	Clay, dry, lumpy	60-75	35°	18-20°	D36
Ashes, fly	40-45	42°	20-25°	A37	Coal, anthracite, sized	55-60	27°	16°	C26
Ashes, gas-producer, wet	78	—	—	D47T	Coal, bituminous, mined 50 mesh and less	50-54	45°	24°	B45T
Asphalt, binder for paving	80-85	—	—	C45	Coal, bituminous, mined and sized	45-55	35°	16°	D35T
Asphalt, crushed, 1/2" and under	45	30-44°	—	C35	Coal, bituminous, mined, run of mine	45-55	38°	18°	D35T
Bagasse	7-10	45°	—	E45Y	Coal, bituminous, stripping, not cleaned	50-60	—	—	D36T
Bakelite and similar plastics, powdered	35-45	45°	—	B45	Coal, lignite	40-45	38°	22°	D36T
Barite	180	30-44°	—	B36	Coke, loose	23-35	30-44°	18°	B37QVT
Barium carbonate	72	45°	—	A45	Coke, petroleum calcined	35-45	30-44°	20°	D36Y
Barium oxide	150-200	—	—	A46	Coke breeze, 1/4" and under	25-35	30-44°	20-22°	C37Y
*Bark, wood, refuse	10-20	45°	27°	E45VY	Compost	30-50	—	—	E45ST
Basalt	80-103	20-28°	—	B26	Concrete, cinder	90-100	—	12-30°	D46
Bauxite, ground, dry	68	20-29°	20°	B26	Copper ore	120-150	30-44°	20°	*D37
Bauxite, mine run	80-90	31°	17°	E37	Copper sulfate	75-85	31°	17°	D36
Bauxite, crushed, 3" and under	75-85	30-44°	20°	D37	Cork, granulated	12-15	—	—	C45
*Bentonite, crude	35-40	42-44°	—	D36X	Corn, shelled	45	21°	10°	C25NW
Bentonite, 100 mesh and under	50-60	42°	20°	A36XY	Cottonseed cake, crushed	40-45	30-44°	—	B35
Boneblack, 100 mesh and under	20-25	20-29°	—	A25Y	Cottonseed cake, lumpy	40-45	30-44°	—	D35W
Bonechar	27-40	30-44°	—	B36	Cottonseed meal	35-40	35°	22°	B35W
Bonemeal	50-60	30-44°	—	B36	Cottonseed meats	40	30-44°	—	B35W
Borate of lime	60	30-44°	—	A35	Cryolite, dust	75-90	30-44°	—	A36
Borax, 1/2" screenings	55-60	30-44°	—	C36	Cryolite, lumpy	90-100	30-44°	—	D36
Borax, 3" and under	60-70	30-44°	—	D35	Cullet	80-120	30-44°	20°	D37Z
Boric acid, fine	55	20-29°	—	B26T	Diatomaceous earth	11-14	30-44°	—	A36MY
Brewer's grain, spent, dry	25-30	45°	—	C45	Dicalcium phosphate	40-50	45°	—	A45
Brewer's grain, spent, wet	55-60	45°	—	C45T	Disodium phosphate	25-31	30-44°	—	B36QT
Calcium carbide, crushed	70-80	30-44°	—	D36N	Dolomite, lumpy	80-100	30-44°	22°	D36
Carbon, activated, dry, fine	8-20	20-29°	—	B26Y	Earth, as excavated — dry	70-80	35°	20°	B36
Carbon black, pelletized	20-25	25°	—	B25Q	Earth, wet, containing clay	100-110	45°	23°	B46

*May vary considerably. Contact your Rexnord representative.

Engineering Data

Table B – Conveying Properties Of Materials – (Cont'd.)

Material	Lbs. per Cu. Ft.	Angle of Repose	Recom'd Max. Incl.	Code	Material	Lbs. per Cu. Ft.	Angle of Repose	Recom'd Max. Incl.	Code
Ebonite, crushed 1/2" and under	65-70	30-44°	—	C35	Potassium nitrate	76-80	20-29°	—	C26T
Emery	230	20-29°	—	A27	Potassium sulfate	42-48	45°	—	B36X
Epson salts	40-50	30-44°	—	B35	Pumice, 1/8" and under	40-45	45°	—	B47
Feldspar, 1/2" screenings	70-85	38°	18°	B36	Pyrites, iron, 2" to 3" lumps	135-145	20-29°	—	D26T
Feldspar, 1 1/2" to 3" lumps	90-110	34°	17°	D36	Pyrites, pellets	120-130	30-44°	—	C36T
Ferrous sulfate	50-75	—	—	C36	Quartz, 1/2" screenings	80-90	20-29°	—	C27Z
Filter press mud, sugar factory	70	—	—	A15	Quartz, 1 1/2" to 3" lumps	85-95	20-29°	—	D27Z
Flue dust, boiler house, dry	35-40	20°	—	A17MTY	Rock, crushed	125-145	20-29°	—	D26
Fluorspar, 1/2" screenings	85-105	45°	—	C46	Rock, soft, excavated with shovel	100-110	30-44°	22°	D36
Fluorspar, 1 1/2" to 3" lumps	110-120	45°	—	D46	Rubber, pelletized	50-55	35°	22°	D35
Foundry refuse, old sand cores, etc.	70-100	30-44°	—	D37Z	Rubber, reclaim	25-30	32°	18°	D35
Fuller's earth, dry	30-35	23°	—	B26	Salicylic acid	29	—	—	B25U
Fuller's earth, oily	60-65	20-29°	—	B26	Salt, common dry, coarse	40-55	—	18-22°	C36TU
Fuller's earth, oil filter, burned	40	20-29	—	B26	Salt, common dry, fine	70-80	25°	11°	D26TUW
Fuller's earth, oil filter, raw	35-40	35°	20°	*B26	Salt cake, dry, coarse	85	36°	21°	B36TW
Glass batch, wool and container	80-100	30-44°	20-22°	D38Z	Salt cake, dry, pulverized	60-85	20-29°	—	B26NT
Glue, pearl	40	25°	11°	C25	Sand, bank, damp	105-130	45°	20-22°	B47
Grain, distillery, spent, dry	30	30-44°	—	E35VY	Sand, bank, dry	90-110	35°	16-18°	B37
Grain, distillery, spent, wet	40-60	45°	—	C45V	Sand, core	65	41°	26°	B35X
Granite, 1/2" screenings	80-90	20-29°	—	C27	Sand, foundry, prepared	80-90	30-44°	24°	B37
Granite, 1 1/2" to 2" lumps	85-90	20-29°	—	D27	Sand, foundry, shakeout	90-100	39°	22°	D37
Granite, broken	95-100	30-44°	—	D37	Sand, silica, dry	90-100	20-29°	10-15°	B27
Graphite, flake	40	30-44°	—	C35	Sandstone, broken	85-90	30-44°	—	D37
Gravel, bank run	90-100	38°	20°	—	Sawdust	10-13	36°	22°	*B35
Gypsum, 1/2" screenings	70-80	40°	21°	C36	Sewage sludge, moist	55	30-44°	—	B36
Gypsum, 1 1/2" to 3" lumps	70-80	30°	15°	D36	Shale, broken	90-100	20-29°	—	D26QZ
Guano, dry	70	20-29°	—	B26	Shale, crushed	85-90	39°	22°	C36
Hops, spent, wet	50-55	45°	—	E45T	Shellac	80	45°	—	C45
Ice, crushed	35-45	19°	—	D16	Shellac, powdered or granulated	31	—	—	B35PY
Ilmenite ore	140-160	30-44°	—	B37	Sinter	100-135	35°	—	*D37
Iron ore	100-200	35°	18-20°	*D36	Slag, blast furnace, crushed	80-90	25°	10°	A27
Iron ore pellets	116-130	30-44°	13-15°	D37Q	Slag, furnace, granular, dry	60-65	25°	13-16°	C27
Iron sulfide	120-135	30-44°	—	D36	Slag, furnace, granular, wet	90-100	45°	20-22°	B47
Kaolin clay, 3" and under	63	35°	19°	D36	Slate, crushed, 1/2" and under	80-90	28°	15°	C36
Lactose	32	30-44°	—	A35PX	Slate, 1 1/2" to 3" lumps	85-95	—	—	D26
Lead arsenate	72	45°	—	B45R	Soap beads or granules	15-25	30-44°	—	C35Q
Lead ores	200-270	30°	15°	*B36RT	Soda ash, briquettes	50	22°	7°	C26
Lead oxides	60-150	45°	—	B45	Soda ash, heavy	55-65	32°	19°	B36
Lead oxides, pulverized	200-250	30-44°	—	A36	Soda ash, light	20-35	37°	22°	A36Y
Lead sulfide	240-260	30-44°	—	A36	Sodium aluminate, ground	72	30-44°	—	B36
Lignite, air-dried	45-55	30-44°	—	*D35	Sodium aluminum sulfate	75	30-44°	—	A36
Lime, ground, 1/8" and under	60-65	43°	23°	B35X	Sodium antimonate, crushed	49	31°	—	C36
*Lime, hydrated, 1/8" and under	40	40°	21°	B35MX	Sodium nitrate	70-80	24°	11°	*D25
Lime, hydrated, pulverized	32-40	42°	22°	A35MXY	Sodium phosphate	50-65	37°	—	B36
Lime, pebble	53-56	30°	17°	D35	Soybeans, whole	45-50	21-28°	12-16°	C27NW
Limestone, agricultural, 1/8" and less	68	30-44°	20°	B36	Starch	25-50	24°	12°	*B25
Limestone, crushed	85-90	38°	18°	C36X	Steel chips, crushed	100-150	30-44°	—	D37WZ
Magnesium chloride	33	40°	—	C45	Steel trimmings	75-150	35°	18°	E37V
Magnesium sulfate	40-50	30-44°	—	—	Sugar, raw, cane	55-65	45°	—	B46TX
Malt, dry, whole	27-30	20-29°	—	C25N	Sugar, refined, granulated, dry	50-55	30-44°	—	B35PU
Malt, wet or green	60-65	45°	—	C45	Sugar, refined, granulated, wet	55-65	30-44°	—	C35X
Manganese dioxide	80	—	—	*	Sugar, beet pulp, dry	12-15	20-29°	—	C26
Manganese ore	125-140	39°	20°	*D37	Sugar, beet pulp, wet	25-45	20-29°	—	C26X
Manganese sulfate	70	30-44°	—	C37	Sugar cane, knifed	15-18	45°	—	E45V
Marble, crushed 1/2" and under	80-95	30-44°	—	D37	Sulfate, crushed, 1/2" and under	50-60	30-44°	20°	C35NS
Marl	80	30-44°	—	C37	Sulfate, 3" and under	80-85	30-44°	18°	D35NS
Mica, flakes	17-22	19°	—	B16MY	Taconite, pellets	116-130	30-44°	13-15°	D37Q
Mica, ground	13-15	34°	23°	*B36	Talc, 1/2" screenings	80-90	20-29°	—	C25
Milk, malted	30-35	45°	—	A45PX	Talc, 1 1/2" to 3" lumps	85-95	20-29°	—	D25
*Molybdenite, powdered	107	40°	25°	B35	Titanium dioxide	140	30-44°	—	B36
Molybdenum ore	107	40°	—	B36	Titanium sponge	60-70	45°	—	E47
Nickel-cobalt, sulfate ore	80-150	30-44°	—	*D37T	Tobacco scraps	15-25	45°	—	D45Y
Oil cake	48-50	45°	—	D45W	Tobacco stems	15	45°	—	E45Y
Oxalic acid crystals	60	30-44°	—	B35SU	Traprock, 1/2" screenings	90-100	30-44°	—	C37
Oyster shells, ground, under 1/2"	50-60	30-44°	—	C36T	Traprock, 2" to 3" lumps	100-110	30-44°	—	D37
Oyster shells, whole	80	30-44°	—	D36TV	Trisodium phosphate, granular	60	30-44°	11°	B35
Paper pulp stock	40-60	19°	—	*E15MV	Trisodium phosphate, pulverized	50	40°	25°	B35
Peanuts, in shells	15-24	30-44°	—	D35Q	Vermiculite, expanded	16	45°	—	C45Y
Peanuts, shelled	35-45	30-44°	—	C35Q	Vermiculite ore	70-80	—	20°	D36Y
Phosphate, acid, fertilizer	60	26°	13°	B25T	Walnut shells, crushed	35-45	30-44°	—	B37
Phosphate, triple super, ground fertilizer	50-55	45°	30°	B45T	Wood chips	10-30	45°	27°	E45WY
Phosphate rock, broken, dry	75-85	25-29°	12-15°	D26	Wood chips, hogged, fuel	15-25	45°	—	D45
Phosphate rock, pulverized	60	40°	25°	B36	Zinc concentrates	75-80	—	—	B26
Polystyrene pellets	35	23°	—	B25PQ	Zinc ore, crushed	160	38°	22°	*
Potash salts, sylvite, etc.	80	20-29°	—	B25T	Zinc ore, roasted	110	38°	—	C36
Potassium carbonate	51	20-29°	—	B26	Zinc oxide, heavy	30-35	45-55°	—	A45X
Potassium chloride, pellets	120-130	30-44°	—	C36T	Zinc oxide, light	10-15	45°	—	A45XY

*May vary considerably. Contact your Rexnord representative.

Engineering Data

Engineering Constants

- 28.8 = equivalent mol. wgt. of air
- 288,000 Btu per 24 hr. = 1 ton of refrigeration
- 29.921 in. Hg at 32° F = atm. press.
- 299 792 458 m/s = velocity of light (c)
- 3 ft. = 1 yard
- 30 in. Hg at 62° F = atmos. press. (very closely)
- 31 (31.5 for some substances) gallons = 1 barrel
- 3.1416 = π (Greek letter "pi") = ratio circumference of circle to diameter = ratio area of circle to square of radius
- 32° F = freezing point of water = 0° C
- 32 = atomic wgt. sulphur (S)
- 32 = mol. wgt. oxygen gas (O₂)
- 32.16 feet/sec² = acceleration of gravity (g)
- 3.2808 ft. = 1 meter
- 33,000 ft.-lb. per min. = 1 hp
- 33.947 ft. water at 62° F = atm. press.
- 3,415 Btu = 1 kw-hr
- 3.45 lb. steam "f.&a. 212" per sq. ft. of heating surface per hr. = rated boiler evaporation.
- 34.56 lb. = wgt. air to burn 1 lb. hydrogen (H)
- 35.314 cu. ft. = 1 cu. meter
- 3.785 liters = 1 gal.
- 39.2° F (4° C) water is at greatest density
- 39.37 in. = 1 meter = 100 cm = 1000 mm
- 3.9683 Btu = 1 kg calorie
- 4,000 Btu (4,050) = cal. val. of sulphur (S)
- 4.32 lb. = wgt. air req. to burn 1 lb. sulphur (S)
- 0.433 lb. per sq. in. = 1 ft. of water at 62° F
- 43,560 sq. ft. = acre
- 44 = mol. wgt. carbon dioxide (CO₂)
- 0.45359 kg. = 1 lb.
- - 460° F (459.6 F) = absolute zero
- 0.47 Btu per pound per °F = approx. specific heat of super-heated steam at atm. press.
- 0.491 lb. per sq. in. = 1 in. Hg at 62° F
- 5.196 lb. per sq. ft. = 1 in. water at 62° F
- 5,280 ft. = 1 mile
- 53.32 = R, a constant for air, expansion equation:

$$PV = MRT$$
- 550 ft.-lb. per sec. = 1 hp.
- 57.296° = 1 radian (angle)
- 58.349 grains per gal = 1 gram per liter
- 59.76 lb. = wgt. 1 cu. ft. water at 212° F
- 61.023 cu. in. = 1 liter
- 62,000 Btu = cal. val. (higher) hydrogen (H)
- 0.62137 miles = 1 kilometer
- 0.062428 lb. per cu. ft. = 1 kg per cu. meter
- 62.5 (62.355) lb. = wgt. 1 cu. ft. water at 62° F
- 645 mm² = 1 sq. in.
- 7,000 grains = 1 lb.
- 0.0735 in. Hg at 62° F = 1 in. water at 62° F
- 746 (745.7) watts = 1 hp.
- 7.5 (7.4805) gal. = 1 cu. ft.
- 760 millimeters Hg = atm. press. at 0° C
- 0.07608 lb. = wgt. 1 cu. ft. air at 62° F and 14.7 per sq. in.
- 778 (777.5) ft.-lb. = 1 Btu (work required to raise 1 lb. water 1° F)
- 0.7854 (= 3.1416 / 4) x diameter squared = area circle
- 8 = lb. oxygen required to burn 1 lb. hydrogen (H)
- 8.025 (= square root of 2_g) x square root of head
 (ft.) = theoretical velocity of fluids in ft. per sec.
- 0.08073 lb. = wgt. 1 cu. ft. air at 32° F and 14.7 lb. per sq. in.
- 8¹/₃ (8.3356) lb. = wgt. 1 gal. water at 62° F
- 8,760 hr. = 1 year of 365 days
- 88 ft. per sec. (min.) = 1 mile per min. (hr.)
- 9 sq. ft. = 1 sq. yard
- 0.0929 sq. meters = 1 sq. ft.
- 970.4 Btu = Latent heat of evap. of water at 212° F

Engineering Data

Expansion Temperature And Color

Expansion of Bodies by Heat

The coefficient of linear expansion (ϵ) is the change in length, per unit of length, for a change of one degree of temperature. The coefficient of surface expansion is approximately two times the linear coefficient, and the coefficient of volume expansion, for solids, is approximately three times the linear coefficient.

A bar, free to move, will increase in length with an increase in temperature and will decrease in length with a decrease in temperature. The change in length will be ϵtl , where (ϵ) is the coefficient of linear expansion, (t) the change in temperature, and (l) the length. If the ends of a bar are fixed, a change in temperature (t) will cause a change in the unit stress of $E\epsilon t$, and in the total (stress of) $A\epsilon Et$, where A is the cross-sectional area of the bar and (E) the modulus of elasticity.

The table below gives coefficients of linear expansion for 10,000,000 degrees (or 10^7 times the value indicated above).

Example:

A piece of ferritic malleable iron is exactly 40 inches long at 60 Fahrenheit. Find the length at 90° Fahrenheit, assuming the ends are free to move.

$$\text{Change of length} = \epsilon tl = \frac{59 \times 30 \times 40}{10^7} = 0.0007 \text{ inches}$$

The length at 90° Fahrenheit is 40.007 inch.

Example:

A piece of ferritic malleable is exactly 40 inches long, ends are fixed. If the temperature increases 30° Fahrenheit, what is the resulting change in unit stress?

$$\text{Change in unit stress} = E\epsilon t = \frac{29,000,000 \times 59 \times 30}{10^7} = 5133 \text{ pounds per square inch}$$

Coefficients of Linear Expansion

Substance	Expansion		Substance	Expansion	
	per 10 ⁷ °F	per 10 ⁷ °C		per 10 ⁷ °F	per 10 ⁷ °C
Aluminum	123-134	221-241	Plastics (acetal, acrylic, nylon, etc.)	445-500	800-900
Brass & Bronzes	90-118	162-212		(may be half these values if glass reinforced)	
Carbides & Ceramets	25-46	45-83	Polyethylene	900-1200	1600-2200
Cast Iron (gray & ductile)	56-88	102-122		20	36
Chromium	34	61	Porcelain		
Concrete	59-79	106-142		428	770
Copper	90-98	162-176	Rubber	55-61	99-110
Glass (plate, crown, flint, soda lime)	44-50	79-90	Sandstone	108	194
(ferrosilicate, pyrex)	18	32	Silver Slate Solder	48-58	86-104
Granite	40-47	72-85		134	241
Ice	283	509	Stainless Steel		
Lead & Alloys	157-163	283-293	Ferritic & Martensitic	52-66	94-119
Limestone	33-50	59-90	Austenitic & Cast	83-104	149-187
Magnesium & Alloys	140-180	252-324	Steel, High Carbon & Alloy	73-84	131-151
Malleable Iron, Ferritic	59	106	Steel, Low Carbon	56-67	101-121
Malleable Iron, Pearlitic	75	135	Tin	116	209
Masonry	31-53	56-95	Titanium & Alloys	45-60	81-108
Phenolics	90-180	160-320	Wood	24-36	43-65
Plaster	92	166	Zinc	141	254

High Temperatures Judged By Color*

Color	Temperature °F	Color	Temperature °F
Dark blood red, black red	990	Orange, free scaling heat	1650
Dark red, blood red, low red	1050	Light orange	1725
Dark cherry red	1175	Yellow	1825
Medium cherry red	1250	Light Yellow	1975
Cherry, full red	1375	White	2200
Light cherry, light red	1550		

*This table associating color and temperature of iron or steel is due to White and Taylor.

Chain and Sprocket Index

Chain No.	Cat. Page	Chain Pitch	Type of Chain	Sprocket	Chain No.	Cat. Page	Chain Pitch	Type of Chain	Sprocket
CHAMP 3	34	3.075	Drive Chain	1030	ROA124	34	4.063	Drive Chain	1240
4	10	4	Elevator and Conveyor	1120	WHX124	38	4	Welded Steel	H124
6	11	6	Elevator and Conveyor	197	WHX124HD	38	4.063	Welded Steel	H124
6SP	11	6	Elevator and Conveyor	1131	C131	51	3.075	Combination	103
ROA 40	34	3.075	Drive Chain	1030	ER131	14	3.075	Elevator and Conveyor	103
ROA40 HYPER	34	3.075	Drive Chain	1030	S131	14		Renamed ER131	
C55	54	1.63	Combination	55	SBS131	14	3.075	Elevator and Conveyor	103
H74	47	2.609	H Mill	78	C132	51	6.05	Combination	132
C77	55	2.308	Combination	67	C132W1	51	6.05	Combination	132
H78	47	2.609	H Mill	78	C132W2	51	6.05	Combination	132
WH78	38	2.609	Welded Steel	78	WHX132	38	6.05	Welded Steel	132
81X	10	2.609	Elevator and Conveyor	78	WSX132	38	6.05	Welded Steel	132
RS81X	10	2.609	Elevator and Conveyor	78	C133	51	6	Combination	133
81XH	10	2.609	Elevator and Conveyor	78	138RT	51	4	Roof-Top	130
RS81XH	10	2.609	Elevator and Conveyor	78	SBS150+	14	6.05	Elevator and Conveyor	132
81XHH	10	2.609	Elevator and Conveyor	78	ERA150	14	6.05	Elevator and Conveyor	132
RS81XHH	10	2.609	Elevator and Conveyor	78	SX150	14		Renamed ER150	
WH82	38	3.075	Welded Steel	103	SXA150	14		Renamed ERA150	
C102B	51	4	Combination	102B	WHX150	38	6.05	Welded Steel	132
ER102B	14	4	Elevator and Conveyor	102B	SS152	38	1.506	Elevator and Conveyor	152
S102B	14		Renamed ER102B		WHX155	38	6.05	Welded Steel	132
SBS102B	14	4	Elevator and Conveyor	102B	WHX157	38	6.05	Welded Steel	132
C102.5	51	4.04	Combination	102.5	WHX159	38	6.125	Welded Steel	132
ER102.5	14	4.04	Elevator and Conveyor	102.5	SX175	14	6.05	Elevator and Conveyor	SX175
S102.5	14		Renamed ER102.5		SR183	10	3	Elevator and Conveyor	183
SBS102.5	14	4.04	Elevator and Conveyor	102.5	C188	51	2.609	Combination	78
WDH104	39	6	Welded Steel	H104	S188	14	2.609	Elevator and Conveyor	78
WHX106	38	6	Welded Steel	106	SBS188	14	2.609	Elevator and Conveyor	78
WHX106XHD	38	6.05	Welded Steel	106	SR188	10	4	Elevator and Conveyor	188
C110	51	6	Combination	110	SR194	10	4	Elevator and Conveyor	194
ER110	14	6	Elevator and Conveyor	110	SR196	11	6	Elevator and Conveyor	196
S110	14		Renamed ER110		RX238	34	3.5	Drive Chain	238
SBS110	14	6	Elevator and Conveyor	110	270	10	2.609	Elevator and Conveyor	270
WH110	38	6	Welded Steel	110	RS303	10	3	Elevator and Conveyor	303
WHD110	39	6	Welded Steel	H110	X345	35	3	Drive Chain	X345
C111	54	4.76	Combination	111	S348	57	3.031	Drop Forged	348
C111W2	54	4.76	Combination	111	X348	57	3.015	Drop Forged	348
ER111	14	4.76	Elevator and Conveyor	111	R362	34	1.654	Drive Chain	62
ES111			Renamed ER111		RR362	10	1.654	Elevator and Conveyor	62
ER111 SP	14	4.760*	Elevator and Conveyor	111SP	R432	34	1.654	Drive Chain	62
ES111SP	14	7.420*	Renamed ER111SP		RR432	10	1.654	Elevator and Conveyor	62
SBS111	14	4.76	Elevator and Conveyor	111	S458	57	4.031	Drop Forged	458
WHX111	38	4.76	Welded Steel	111	468	57	4.031	Drop Forged	468
WDH112	39	8	Welded Steel	H112	S468	57	4.031	Drop Forged	468
WDH113	39	6	Welded Steel	H110	WDH480	39	8	Welded Steel	H480
WDH116	39	8	Welded Steel	H116	R506	34	2.3	Drive Chain	506
WDH118	39	8	Welded Steel	WD118	B508H	3	2.62	Drive Chain	508
CC119	48	6	Cast Steel Drag	119	R514	34	2.5	Drive Chain	514
SM120	64	2.5	Double Flex	9250	A520	34	2.563	Drive Chain	520
WDH120	39	6	Welded Steel	H120	531	10	4	Elevator and Conveyor	531
H124	47	4	Cast Drag	H124					
C124W	51	4.063	Combination	1240					
B9856	11	6.000	Elevator and Conveyor	9856					

*Two-Pitch Chain

Chain and Sprocket Index

Chain No.	Cat. Page	Chain Pitch	Type of Chain	Sprocket	Chain No.	Cat. Page	Chain Pitch	Type of Chain	Sprocket
RR542	11	6	Elevator and Conveyor	110	ER956	14	6	Heavy Duty Elevator	856
B578	34	2.609	Drive Chain	78	ER958	14	6	Heavy Duty Elevator	958
RO578	34	2.609	Drive Chain	78	RS960	11	6	Elevator and Conveyor	2124
WDH580	39	8	Welded Steel	H480	977	48	2.308	Pintle	67
R588	34	2.609	Drive Chain	78	ER984	14	7	Heavy Duty Elevator	984
RR588	10	2.609	Elevator and Conveyor	78	988	48	2.609	Pintle	78
SMGL618	52	6	Combination	SMGL618	RS996	11	6	Elevator and Conveyor	2124
ROA620	34	1.654	Drive Chain	62	998	58	9.031	Drop Forged	998
SM621	52	9	Combination	SM621	S998	57	9.031	Drop Forged	998
SM622	52	6	Combination	SM622	1030	34	3.075	Drive Chain	1030
RO622	34	1.654	Drive Chain	62	ROA1031	34	3.075	Drive Chain	1030
RS625	10	1.654	Elevator and Conveyor	62	ROA1032	34	3.075	Drive Chain	1030
RS627	10	1.654	Elevator and Conveyor	62	R1033	34	3.075	Drive Chain	1030
SMGL628	52	6	Combination	SMGL628	R1035	34	3.075	Drive Chain	1030
RO635	34	4.5	Drive Chain	635	1036	11	6	Elevator and Conveyor	1036
RS658	11	6	Elevator and Conveyor	1604	R1037	34	3.075	Drive Chain	1030
S678	57	6.031	Drop Forged	678	1039	12	9	Elevator and Conveyor	1039
X678	57	6.031	Drop Forged	678	SS1088	10	2.609	Elevator and Conveyor	78
WDH680	39	8	Welded Steel	H480	RS1113	10	4.04	Elevator and Conveyor	1113
698	58	6.031	Drop Forged	698	RS1114	11	6	Elevator and Conveyor	196
S698	57	6.031	Drop Forged	698	SR1114	11	6	Elevator and Conveyor	196
720S	48	6	Pintle	720S	RR1120	10	4	Elevator and Conveyor	1120
C720	48	6	Pintle	720S	RS1131	11	6	Elevator and Conveyor	1131
CS720S	48	6	Pintle	CS720S	A1204	34	5	Drive Chain	1204
A730	48	6	Pintle	A730	RO1205	34	5	Drive Chain	1207
CS730	48	6	Pintle	CS730	RX1207	34	5	Drive Chain	1207
RO770	34	2.3	Drive Chain	506	E1211	13	12	Elevator and Conveyor	E1211
R778	34	2.609	Drive Chain	78	RS1211	13	12	Elevator and Conveyor	E1211
RR778	10	2.609	Elevator and Conveyor	78	ER1222	13	12	Elevator and Conveyor	E1222
S823	14	4	Elevator and Conveyor	823	FR1222	13	12	Elevator and Conveyor	F1222
SR825	14	4	Elevator and Conveyor	825	SS1222	13	12	Elevator and Conveyor	F1222
SR830	14	6	Elevator and Conveyor	830	SS1227	13	12	Elevator and Conveyor	E1222
ER833	14	6	Elevator and Conveyor	833	SS1232	13	12	Elevator and Conveyor	F1232
ER833	14		Renamed ER833		ER1233	13	12	Elevator and Conveyor	E1233
SBS844	14	6	Elevator and Conveyor	844	FR1233	13	12	Elevator and Conveyor	F1233
SR844	14	6	Elevator and Conveyor	844	SS1233	13	12	Elevator and Conveyor	F1233
RO850	14	6	Elevator and Conveyor	RO850	A1236	34	4.063	Drive Chain	A1236
SBS850+	14	6	Elevator and Conveyor	RO850	1240	34	4.063	Drive Chain	1240
SBO850+	14	6	Elevator and Conveyor	RO850	ROA1242	34	4.063	Drive Chain	1240
ER856	14	6	Elevator and Conveyor	856	1244	34	4.063	Drive Chain	1240
RS856	14		Renamed ER856		ER1244	14	12	Elevator and Conveyor	E1244
SBX856	14	6	Elevator and Conveyor	856	FR1244	14	12	Elevator and Conveyor	F1244
ER857	14	6	Heavy Duty Elevator	856	RX1245	34	4.073	Drive Chain	1240
ER859	14	6	Heavy Duty Elevator	859	R1248	34	4.063	Drive Chain	1240
ER864	14	7	Heavy Duty Elevator	864	R1251	13	12	Elevator and Conveyor	2397
ROA881	34	2.609	Drive Chain	78	C1288	10	2.609	Elevator and Conveyor	78
ROA882	34	2.609	Drive Chain	78	1301	34	5.75	Drive Chain	1301
RS886	10	2.609	Elevator and Conveyor	78	RO1306	34	6	Drive Chain	1306
SX886	14	7	Heavy Duty Elevator	SX886	ROS1306	34	6	Drive Chain	1306
RS887	10	2.609	Elevator and Conveyor	78	X1307	34	7	Drive Chain	1307
901	49	3.149	Pintle	901	A1309	35	7	Drive Chain	A1309
902	49	2.97	Pintle	902	X1311	34	6.5	Drive Chain	X1311
907	49	3.17	Pintle	907	RO1315	34	5	Drive Chain	RO1315
ER911	12	9	Elevator and Conveyor	E911	AX1338	34	3.625	Drive Chain	AX1338
RS911	12	9	Elevator and Conveyor	E911	X1343	34	4.09	Drive Chain	X1343
ER922	12	9	Elevator and Conveyor	E922	X1345	34	4.09	Drive Chain	X1345
FR922	12	9	Elevator and Conveyor	F922	X1351	34	4.125	Drive Chain	X1351
SS922	12	9	Elevator and Conveyor	F922	X1353	35	4.09	Drive Chain	X1353
SS927	12	9	Elevator and Conveyor	E922	RO1355	34	5	Drive Chain	RO1355
SS928	12	9	Elevator and Conveyor	SS928	RO1356	34	5.5	Drive Chain	RO1356
ER933	12	9	Elevator and Conveyor	E933	X1365	35	6	Drive Chain	X1365
FR933	12	9	Elevator and Conveyor	F933	1535	14	3.075	Elevator and Conveyor	1535
SS933	12	9	Elevator and Conveyor	F933	1536	14	3.075	Elevator and Conveyor	1536
SS942	12	9	Elevator and Conveyor	SS942	1539	10	3.075	Elevator and Conveyor	1030
RS944+	11	6	Elevator and Conveyor	2111	RS1539	10	3.075	Elevator and Conveyor	1030
945	48	1.63	Pintle	45	AX1568	34	3.067	Drive Chain	1568
RS951	11	6	Elevator and Conveyor	1131	1578	10	2.609	Elevator and Conveyor	78
S951	11	6	Elevator and Conveyor	S951	1604	11	6	Elevator and Conveyor	1604
RS953	11	6	Elevator and Conveyor	953	1617	11	6	Elevator and Conveyor	197
955	48	1.63	Pintle	45	SS1654	14	6	Elevator and Conveyor	1654

Chain and Sprocket Index

Chain No.	Cat. Page	Chain Pitch	Type of Chain	Sprocket	Chain No.	Cat. Page	Chain Pitch	Type of Chain	Sprocket
1670	11	6	Elevator and Conveyor	2180	3160CM	35	2	Drive Chain	ANSI #160
R1706	13	12	Elevator and Conveyor	2452	ROA 3160	35	2	Drive Chain	ANSI #160
ER1822	13	18	Elevator and Conveyor	E1822	ROA3160S	34	2	Drive Chain	3112
FR1822	13	18	Elevator and Conveyor	F1822	3180	35	2.25	Drive Chain	ANSI #180
F1833	13	18	Elevator and Conveyor	F1833	3285	10	4.5	Elevator and Conveyor	3285
FR1844	13	18	Elevator and Conveyor	F1844	ROA3315	34	4.073	Drive Chain	1240
SBS1972	14	3.075	Elevator and Conveyor	1536	3420	10	4.04	Elevator and Conveyor	1113
SS2004	10	2.609	Elevator and Conveyor	270	3498	64	1.750*	Double Flex	3498
ROA2010	34	2.5	Drive Chain	514			2.500*		3498
RS2047	11	6	Elevator and Conveyor	2047	3500	64	2.500*	Double Flex	3500
RS2064	12	9	Elevator and Conveyor	2064			3.500*		3500
SBO2103	14	3.075	Elevator and Conveyor	103	ROA3618	34	4.5	Drive Chain	635
BR2111	11	6	Elevator and Conveyor	2111	WHX3855	38	6.05	Welded Steel	132
RO2113	10	4.04	Elevator and Conveyor	1113	X4004	12	9	Elevator and Conveyor	4004
A2124	11	6	Elevator and Conveyor	2124	RF4007	62	4	Roller Conveyor	RF4007
C2124	11	6	Elevator and Conveyor	2124	R4009	12	9	Elevator and Conveyor	4009
2126	11	6	Elevator and Conveyor	196	R4010	13	12	Elevator and Conveyor	4010
SBS2162	14	3.075	Elevator and Conveyor	1535	4011	13	12	Elevator and Conveyor	4011
A2178	11	6	Elevator and Conveyor	2124	RF4011	62	4	Roller Conveyor	RF4011
2180	11	6	Elevator and Conveyor	2180	RS4013	10	4	Elevator and Conveyor	1120
2183	11	6	Elevator and Conveyor	1131	RS4019	10	4	Elevator and Conveyor	1120
F2183	11	6	Elevator and Conveyor	S951	ROA4020	34	5	Drive Chain	1207
FX2184	11	6	Elevator and Conveyor	1131	SS4038	13	12	Elevator and Conveyor	4038
2188	10	4	Elevator and Conveyor	188	4065	12	9	Elevator and Conveyor	4065
RS2188	10	4	Elevator and Conveyor	188	RS4065	12	9	Elevator and Conveyor	4065
RO2184	11	6	Elevator and Conveyor	1131	RS4113	10	4	Elevator and Conveyor	188
2190	11	6	Elevator and Conveyor	197	RS4216	10	4	Elevator and Conveyor	194
RS2190	11	6	Elevator and Conveyor	197	RS4328	10	4	Elevator and Conveyor	531
A2198	11	6	Elevator and Conveyor	2124	A4539	10	3.075	Elevator and Conveyor	4539
WDH2210	40	6.136	Welded Steel Drag	H110	ROA4824	34	6	Drive Chain	1306
SBS2236	14	4	Elevator and Conveyor	2236	ROB4824	34	6	Drive Chain	1306
RO2284	11	6	Elevator and Conveyor	1131	RS4850	13	12	Elevator and Conveyor	4011
RO2284+	11	6	Elevator and Conveyor	1131	RS4851	12	9	Elevator and Conveyor	4009
WDH2316	40	8.126	Welded Steel Drag	H116	RS4852	12	9	Elevator and Conveyor	4004
R2342	12	9	Elevator and Conveyor	2342	WHX4855	38	12	Welded Steel	4855
WDH2380	40	8.161	Welded Steel Drag	H480	SBS4871	14	9	Elevator and Conveyor	1903
RR2397	13	12	Elevator and Conveyor	2397	ROA5035	34	5	Drive Chain	RO1315
R2405	12	9	Elevator and Conveyor	2342	WHX5121	41	9	Welded Steel Drag	6121
ROA2512	34	3.067	Drive Chain	1568	WHX5157	41	6.05	Welded Steel Drag	5157
RS2600	11	6	Elevator and Conveyor	2600	5208	11	6	Elevator and Conveyor	5208
R2614	13	12	Elevator and Conveyor	2614	RO5542	34	5.5	Drive Chain	RO1356
A2800	12	8	Elevator and Conveyor	2800	ROA5738	34	5.75	Drive Chain	1301
RS2800	12	8	Elevator and Conveyor	2800	RS6018	11	6	Elevator and Conveyor	196
RS2804	12	8	Elevator and Conveyor	2804	SBO6065	14	6	Elevator and Conveyor	6065
RS2806	11	8	Elevator and Conveyor	2806	WHX6067	41	9	Welded Steel Drag	6121
ROA2814	34	3.5	Drive Chain	238	WHX6121	41	9	Welded Steel Drag	6121
R2823	14	4	Elevator and Conveyor	823	RO6214	34	4	Drive Chain	RO6214
C2848	10	4.04	Elevator and Conveyor	2848	RS6238	11	6	Elevator and Conveyor	197
WHX2855	38	6.05	Welded Steel	132	6425R	35	2.5	Drive Chain	645
SBX2857	14	6	Elevator and Conveyor	856	RS6438	11	6	Elevator and Conveyor	1131
2858	10	4.083	Elevator and Conveyor	2858	RO6555	34	7	Drive Chain	X1311
SBX2859	14	6	Elevator and Conveyor	859	RO6706	34	3.075	Drive Chain	RO6706
SBX2864	14	7	Elevator and Conveyor	864	6826	14	6	Elevator and Conveyor	6826
A2868	10	4	Elevator and Conveyor	2868	RO7080	35	7	Drive Chain	A1309
RF3007	62	3	Roller Conveyor	RF3007	7539	10	3.11	Elevator and Conveyor	7539
RF3011	62	3	Roller Conveyor	RF3011	7774	10	2.609	Elevator and Conveyor	270
RS3013	10	3	Elevator and Conveyor	183	C9103	48	3.075	Pintle	103
RS3017	35	3	Drive Chain	X345	SCA9103	48	3.075	Pintle	103
R3112	34	2	Drive Chain	3112	9118	57	9.031	Drop Forged	9118
B3113	34	2	Drive Chain	3112	S9118	58	9.031	Drop Forged	9118
3120CM	35	1.5	Drive Chain	ANSI #120	FX9184	11	6	Elevator and Conveyor	9184
ROA3120	35	1.5	Drive Chain	ANSI #120	9250	64	2.5	Double Flex	9250
3125	34	3.125	Drive Chain	3125	RX9506H	34	6	Drive Chain	1306
3125-2	34	3.125	Drive Chain	D31	C9856	11	6	Elevator and Conveyor	9856
ROA3125 HYPER	34	3.125	Drive Chain	3125	B9856	11	6	Elevator and Conveyor	9856
ROA3125-2 HYPER	34	3.125	Drive Chain	D31					
SR3130	11	6	Elevator and Conveyor	197					
3140CM	35	1.75	Drive Chain	ANSI #140					
ROA3140	35	1.75	Drive Chain	ANSI #140					

*Two-Pitch Chain

Subject Index

A		D	
Amusement ride applications	5	Decimal/fraction/metric conversion table	120
Appendix Information		Design And Selection	
Chain and sprocket index	129-131	Applications beyond scope of catalog selection	113
Engineering information	120-128	Chain selection procedures	
Subject index	132-133	Conveyor chain selection	103-112
B		Elevator chain selection	112
Buckets, elevator	85-86	Drive chain selection	87-102
C		Heat treatment—see Heat Treatment	
Cast and chill iron sprocket hubs	72-73	Double flex chains, metal	63-64
Cast Chains		Drag Chain	
Attachments	53-55	Center distance	121
Combination chain	51-52	Chain length	122
Mill chain	47	Cast chains	
Pintle chain	48	Welded chains	41
Catenary	122-123	Drive chain selection, Engineered class	87-102
Center distance calculation, minimum	121-122	Drive Chains	
Chain Accessories		3100 series – chain listings	32
Elevator buckets	85-86	Drive chain listings	34-35
Segmental rim sprockets & traction wheels	81-84	General information	30-32
General information	81	Offset sidebar drive chains	34
Split hub bodies	83	Selection procedures – using tables	87-102
Solid hub bodies	82	Selection tables	93-102
Cast rims	84	Service factors	92-93
Sprockets	66-80	Straight sidebar chains	35
Cast sprocket listing	74-79	System design considerations	87
Fabricated steel sprockets	70-71	Drivemaster	33, 118
Cast sprocket hubs – solid	72	Drop Forged	
How to order	69	Attachments	58-61
Cast drum flanged traction wheels	80	Chain listings	57
Selection and specification	67-68	E	
Octagonal tail wheels	71	Elevator And Conveyor Chains	
Sprocket types	66	Attachments	15-29
Fabricated split hubs	70	Cast chains	47-55
Sprockets and traction wheels	66	Chains with rollers	10-13
Cast traction wheels	80	Chains without rollers	14
Cast sprocket hubs – split	72	Conveyor selection procedures	103-112
Fabricated solid hubs	70	Double flex chain sprockets	63
Chain breakers	118-119	Double flex chains, metal	63-64
Chain interchange	65	Drop forged chains	57-61
Chain length, minimum	122	Elevator chain pull calculation	112
Chain and sprocket index	129-131	Live roller conveyor chains	62
Chordal action	90	Welded steel chains	36-46
Combination chain	51-52	Elevator buckets	85-86

Subject Index

Engineered Steel Chain

Connecting and Disconnecting	114-115
Conveyor and elevator chain	29
Design information – see Design And Selection	
Expansion temperature and color	128
Lubrication materials and processes	116-117
Engineering constants	126

G

Guide to welding attachments	42
------------------------------	----

H

Hardness and strength comparison tables	127
---	-----

Heat Treatment

Sprockets	67
Welded steel chain options	36-37
Heavy duty drag chain	41
Hollow pin chain	62
H-type mill, cast	47

I

Idler Wheels

Cast drum flanged	89
Interchange – chain	65

K

Keyways, standard dimensions	121
------------------------------	-----

L

Linkmaster	119
Live roller conveyor chains	62

M

Maintenance Information

Assembly/disassembly tools	118-119
Connecting and disconnecting chain	114-115
Conveyor chain maintenance	117
Drive chain maintenance	116
Material characteristics, conveyed materials	124-125
Metric/decimal/fraction conversion table	120
Mill chain, cast	47

P

Pintle chain	48
Power and cycle calculations	122

S

S Series drop forged chain	57
Segmental rim sprockets and traction wheels	81-84
Selection procedure, see Design And Selection	
Special Application Chain	
Amusement rides	5
Bottling and beverage industry	7
Cane sugar and beet processing	8
Distribution and material handling	9
Draw bench and steel industry chains	6
Food processing	8
Grain handling chain	4
High performance elevator chains	4
High sidebar chain	9
In-floor conveying chain	6
Reclaimer and barge/ship unloading chains	7
Sprocket/chain index	129-131
Sprocket pitch diameters	120
Sprockets, see Chain Accessories	
Sprockets traction wheels, see Chain Accessories	
Strength of materials	127

W

Welded Steel Chain

Attachments	43-46
Drag chain	41
Drag chain head sprockets	71
Drag chain sprockets	71
Drag chain tail sprockets	71
General information	36-37
Heat treatment processes	36-37
Heavy duty drag chain	41
Narrow series	38
Reverse barrell wide mill drag chain	40
Welding instructions	42
Wide series	39
Welding instructions, welded and chain	42
Weights and conveying characteristics of materials	124-125

Please note that the sections on Polymeric chains have been removed from this catalog.

Notes

Notes

Why Choose Rexnord?

When it comes to providing highly engineered products that improve productivity and efficiency for industrial applications worldwide, Rexnord is the most reliable in the industry. Commitment to customer satisfaction and superior value extend across every business function.

Delivering Lowest Total Cost of Ownership

The highest quality products are designed to help prevent equipment downtime and increase productivity and dependable operation.

Valuable Expertise

An extensive product offering is accompanied by global sales specialists, customer service and maintenance support teams, available anytime.

Solutions to Enhance Ease of Doing Business

Commitment to operational excellence ensures the right products at the right place at the right time.

Rexnord Corporation

Rexnord is a growth-oriented, multi-platform industrial company with leading market shares and highly trusted brands that serve a diverse array of global end markets.

Process and Motion Control

The Rexnord Process and Motion Control platform designs, manufactures, markets and services specified, highly engineered mechanical components used within complex systems where our customers' reliability requirements and the cost of failure or downtime are extremely high.

Water Management

The Rexnord Water Management platform designs, procures, manufactures and markets products that provide and enhance water quality, safety, flow control and conservation.

