



# Falk Steelflex Grid Couplings

(Metric)



## Table Of Contents

DESCRIPTION	PAGE
Falk® Steelflex® Grid Coupling Application Guide . . . . .	3
How to Select . . . . .	4, 5, 6
Quick Selection Method . . . . .	7, 8
Service Factors . . . . .	9, 10
How to Order . . . . .	10
Products . . . . .	10
<b>CLOSE-COUPLED COUPLINGS</b>	
Close-Coupled Type T10 . . . . .	11
Close-Coupled Type T20 . . . . .	12
<b>SPACER COUPLINGS</b>	
Full Spacer Type T31 . . . . .	13, 14
Half Spacer Type T35 . . . . .	15, 16
<b>CONTROLLED TORQUE PRODUCTS</b>	
Controlled Torque Types T41, T41-2 . . . . .	17
Controlled Torque Clutches Types T44 & T44-2 . . . . .	18
Piloted Controlled Torque Type T45 . . . . .	19
Optional Automatic Proximity Sensor Cutout Switch . . . . .	20
Slip Torque Performance Charts . . . . .	21, 22, 23, 24
<b>SPECIALTY COUPLINGS</b>	
Floating Shaft Type T50 . . . . .	25, 26
Caliper Disc Brake System . . . . .	27
Disc Brake Type T63 . . . . .	28, 29
High-Speed Type T70 . . . . .	30
Engine Flywheel Adapter Type T90 . . . . .	31
Floating Shaft Type T10/G82 . . . . .	32
<b>TECHNICAL DATA</b>	
Engineering Data . . . . .	33 – 42
Coupling Application Data Sheet . . . . .	43

# Falk Steelflex Grid Coupling Application Guide

A general purpose, lubricated design that combines the economy and high torque capacity of a gear coupling with the torsional flexibility of an elastomeric coupling. Backed by a 5-year lubrication warranty, Falk Steelflex couplings require no periodic maintenance when lubricated with Falk LTG at installation. Featuring 25 sizes, Steelflex couplings can accommodate torque loads of 932,000 (Nm) and shaft diameters of 508 millimeters.

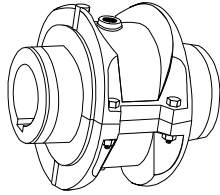

A double-flexing, close-coupled design for use in four-bearing systems. Features a horizontally split cover which allows for grid replacement without the movement of the connected equipment.

(See **page 11.**)

**Type T10 Close-Coupled**

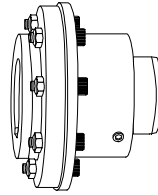

For use on line shaft applications. Can be used in place of single-engagement gear couplings to provide torsional resiliency and lower overall operating cost.

(See **pages 25 and 26.**)

**Type T50 Piloted**

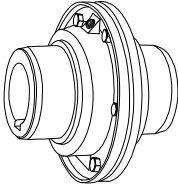

A double-flexing design featuring a vertically-split steel cover. Ideal for higher running speeds.

(See **page 12.**)

**Type T20 Close-Coupled**

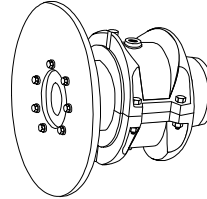

Proven to be far superior to drum-type brakes in cost, construction and performance.

(See **pages 27-29.**)

**Type T63 Disc Brake**

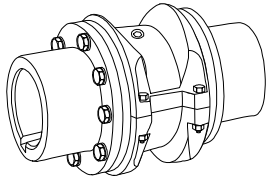

Complete center section drops out for easy service of connected equipment bearings and seals. Ideal for pump applications.

(See **pages 13 and 14.**)

**Type T31 Full Spacer**

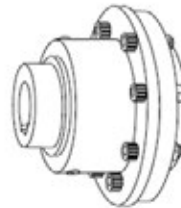

Designed for operating speeds beyond those of the T10 and T20 designs. Features a one-piece cover and balanced components.

(See **page 30.**)

**Type T70 High Speed**

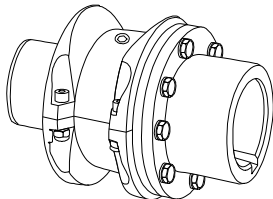

An economical spacer design for easy service of connected equipment bearings and seals. Ideal for pump applications.

(See **pages 15 and 16.**)

**Type T35 Half Spacer**

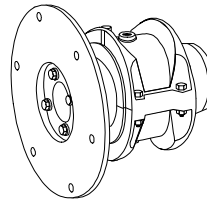

Used primarily to connect the flywheel of an engine to the driven machinery. It provides higher torque ratings with resulting smaller sizes and lower costs than elastomeric couplings.

(See **page 31.**)

**Type T90 Flywheel**

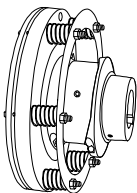

Provides adjustable slipping action to protect connected equipment from shock, jams or temporary overloads.

(See **pages 17-24.**)

**Type T41/T44 Controlled Torque**

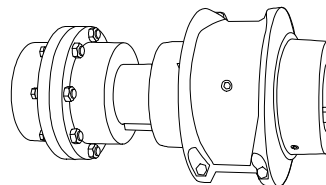

A combination of two standard Rexnord couplings. Utilizes readily available components for an economical price and shorter lead time than T31/T35 couplings.

(See **page 32.**)

**Type T10/G82 Spacer**

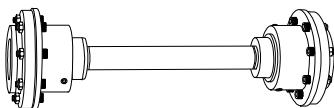

Double-piloted design for connecting equipment where the distance between shafts is too large for a spacer-type coupling.

(See **pages 25 and 26.**)

**Type T50 Floating Shaft**

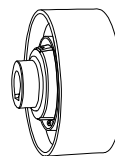

Provides a built-in breaking surface right at or near the centerline of the coupling ... saves space and dollars.

(See Selection Guide 431-310.)

**Type BW Brakewheel**

**CAUTION! Mixing grid coupling components from *different* manufacturers may cause premature failure and possible personal injury or property damage from flying debris.**

## How to Select

### Standard Selection Method (except T41/T44 & T63)

The standard selection method can be used for most motor, turbine or engine-driven applications. The following information is required to select a flexible coupling:

- Horsepower or torque.
- Running rpm.
- Application or type of equipment to be connected (motor to pump, gear drive to conveyor, etc.).
- Shaft diameters.
- Shaft gaps.
- Physical space limitations.
- Special bore or finish information and type of fit.

**Exceptions are High Peak Loads and Brake Applications. For these conditions use the Formula Selection Method in the next column, or consult your local Rexnord representative for assistance.**

1. **Rating:** Determine system torque. If torque is not given, calculate as shown below:

$$\text{System Torque (Nm)} = \frac{\text{kW} \times 9549}{\text{Rpm}}$$

Where horsepower is the actual or transmitted power required by the application (if unknown, use the motor or turbine nameplate rating) and rpm is the actual speed the coupling is rotating. Applications that require rapid changes in direction or torque reversals should be referred to Rexnord Engineering.

2. **Service Factor:** Determine appropriate service factor from **Table 4, page 9**.
3. **Required Minimum Coupling Rating:** Determine the required minimum coupling rating as shown below:  
$$\text{Minimum Coupling Rating} = \text{S.F. (Service Factor)} \times \text{Torque (Nm)}$$
4. **Type:** Refer to **page 3** and select the appropriate coupling type.
5. **Size:** Turn to appropriate pages for the coupling type chosen and trace down the torque column to a value that is equal or greater than that determined in Step 3 above. The coupling size is shown in the first column.
6. **Check:** Check speed (rpm), bore, gap and dimensions.

#### Standard Selection Example:

Select a coupling to connect a 55 kw, 1500 rpm electric motor driving a lobe-type blower. Motor shaft diameter is 60 mm, blower shaft diameter is 60 mm. Shaft extensions are 140 mm and 110 mm. Selection is replacing a gear-type coupling with a 3 mm gap.

1. **Determine Required Rating:**

$$\text{System Torque (Nm)} = \frac{55 \text{ kW} \times 9549}{1500 \text{ Rpm}} = 350 \text{ Nm}$$

2. **Service Factor:** From **Table 4** = 1,25
3. **Required Minimum Coupling Rating:**  
$$1,25 \times 350 \text{ Nm} = 438 \text{ Nm}$$
4. **Size:** From **page 11** a Size 1070T is the proper selection based on a torque rating of 904 Nm exceeding the required minimum coupling rating of 438 Nm.
5. **Check:** Allowable speed capacity of 4125 (T10) exceeds the required speed of 1500 rpm. Maximum bore capacity of 67 mm exceeds the actual shaft diameters.

### Type T63 Static (Holding) Brake Applications

1. **Size:** The brake rating must equal or exceed the application requirements. Determine the required coupling size by comparing the application loads (from Steps A and B below) to the coupling brake rating listed on **page 28**. Use the highest torque value calculated to determine the coupling size.

- A. For normal service applications, use the application torque in Nm.

$$\text{System Torque (Nm)} = \frac{\text{Transmitted kW} \times 9549}{\text{Rpm}}$$

- B. For repetitive high peak load applications, use the system peak torque in Nm. (Repetitive is defined as more than 1000 times during the expected coupling life.)

2. **Caliper Torque Brake Rating:** For the coupling size selected, compare the caliper brake torque rating on **page 28** to the holding torque requirement of the application. Rexnord recommends that the caliper torque rating (min.) be at least two times the holding torque requirement for static applications to compensate for the possibility of foreign matter on the disc surfaces, loss of condition of the brake pad surfaces, or other conditions that may affect the holding ability of the caliper brake.

Caliper brakes and brake discs listed are designed primarily for static and/or emergency brake applications. **NOTE:** Check brake system and lining wear after emergency stops. They can, however, also be used for dynamic stopping if only used occasionally, such as shutting down the equipment for the day or between shift changes. For stopping high-inertia systems or for applications that require more frequent stopping, consult your local Rexnord representative.

3. **Check:** Check maximum bores, speeds and dimensions.

### Type T63 Stopping or Service Brake Applications

1. **Size:** The coupling brake rating must equal or exceed the application requirements. Determine the required coupling size by comparing the application loads (from Steps A, B and C below) to the coupling brake rating listed on **page 28**. Use the highest torque value calculated to determine the coupling size.

- A. For the selected caliper brake and disc diameter, use the maximum brake torque in Nm.

- B. For normal service applications, use the application torque in Nm.

$$\text{System Torque (Nm)} = \frac{\text{Transmitted kW} \times 9549}{\text{Rpm}}$$

- C. For repetitive high peak load applications, use the system peak torque in Nm. (Repetitive is defined as more than 1000 times during the expected coupling life.)

2. **Check:** Check maximum bores, speeds and dimensions.

## How to Select

### Formula Selection Method (except T41/T44 & T63)

The Standard Selection Method can be used for most coupling selections. The procedures below should be used for:

- High Peak Loads.
- Brake Applications (where the brake disc or brake wheel is to be an integral part of the coupling, consult the Factory for design options).

Providing system peak torque and frequency, duty cycle and brake torque rating will allow for a more refined selection using the Formula Selection Method.

1. **High Peak Loads:** Use one of the following formulas for applications using motors with torque characteristics that are higher than normal; applications with intermittent operations, shock loading, inertia effects due to starting and stopping and/or system-induced repetitive high peak torques. System Peak Torque is the maximum torque that can exist in the system. Select a coupling with a torque rating equal to or greater than selection torque calculated below.

#### A. Non-Reversing High Peak Torque

$$\text{Selection Torque (Nm)} = \text{System Peak Torque}$$

or

$$\text{System Torque (Nm)} = \frac{\text{System Peak kW} \times 9549}{\text{Rpm}}$$

#### B. Reversing High Peak Torque

$$\text{Selection Torque (Nm)} = 2 \times \text{System Peak Torque}$$

or

$$\text{System Torque (Nm)} = \frac{2 \times \text{Peak kW} \times 9549}{\text{Rpm}}$$

- C. Occasional Peak Torques (Non-reversing) If a system peak torque occurs less than 1000 times during the expected coupling life, use the following formula:

$$\text{Selection Torque (Nm)} = 0,5 \times \text{System Peak Torque}$$

or

$$\text{System Torque (Nm)} = \frac{0,5 \times \text{Peak kW} \times 9549}{\text{Rpm}}$$

For reversing service select per step B.

2. **Brake Applications:** If the torque rating of the brake exceeds the motor torque, use the brake rating as follows:

$$\text{Selection Torque (Nm)} = \text{Brake Torque Rating} \times \text{S.F.}$$

### Formula Selection Example — High Peak Load:

Select a coupling for reversing service to connect a gear drive low-speed shaft to a runout mill table roll. The electric motor rating is 37 kW at the base speed and the system peak torque at the coupling is estimated to be 17000 Nm. Coupling speed is 77 rpm at the motor base speed. The drive shaft diameter is 100 mm with a key of 28 mm x 16 mm. The runout table roll diameter is 135 mm with a key of 36 mm x 20 mm. Maximum shaft gap is 180 mm long.

1. **Type:** Refer to **page 3** and select the appropriate coupling type.

#### 2. Required Minimum Coupling Rating:

Use the Reversing High Peak Torque formula in Step 1B.

$$2 \times 17000 = 34000 \text{ Nm} = \text{Selection Torque}$$

3. **Size:** From **page 16**, Size 1150T35 with a torque rating of 39800 Nm exceeds the selection torque of 34000 Nm.

4. **Check:** The 1150T35 has a maximum BE dimension of 187,5 mm; the shaft hub 270 mm, (**Table 15, page 34**); the T hub bore has a maximum bore of 215 mm) with one rectangular key (**Table 14, page 34**); and the allowable speed of 1500 rpm and the dimensions on **page 16**, meet the requirements.

**Table 1 — Coupling Ratings & Allowable Speeds**

Coupling Size ①	kW per 100 Rpm ②	Torque Rating (Nm) ③	Allowable Speeds — Rpm ④			
			T10	T20 & T50 ⑤	T31, T35 & T10/G82	T70
1020T	0,005	52	4500	6000	3600	—
1030T	0,016	149	4500	6000	3600	10000
1040T	0,026	249	4500	6000	3600	—
1050T	0,046	435	4500	6000	3600	9000
1060T	0,072	684	4350	6000	3600	—
1070T	0,104	994	4125	5500	3600	8200
1080T	0,215	2050	3600	4750	3600	7100
1090T	0,390	3730	3600	4000	3600	6000
1100T	0,657	6280	2440	3250	2440	4900
1110T	0,976	9320	2250	3000	2250	4500
1120T	1,43	13 700	2025	2700	2025	4000
1130T	2,08	19 900	1800	2400	1800	3600
1140T	2,99	28 600	1650	2200	1650	3300
1150T	4,16	39 800	1500	2000	1500	—
1160T	5,86	55 900	1350	1750	1350	—
1170T	7,81	74 600	1225	1600	1225	—
1180T	10,8	103 000	1100	1400	1100	—
1190T	14,3	137 000	1050	1300	1050	—
1200T	19,5	186 000	900	1200	900	—
1210T	26,0	249 000	820	—	—	—
1220T	35,1	336 000	730	—	—	—
1230T	45,6	435 000	680	—	—	—
1240T	58,6	559 000	630	—	—	—
1250T	78,1	746 000	580	—	—	—
1260T	97,6	932 000	540	—	—	—

① Refer to **page 10** for General Information.

② kW per 100 Rpm and torque rating values for hubs with Taper-Lock® bushings differ from those shown above. Refer to **Table 18, page 36**.

③ Peak torque capacity is two times the published rating. Torque ratings for hubs with bushings differ from those shown, refer to **Table 18, page 36**.

④ Consult Factory for higher speeds.

⑤ Speeds shown above are for single Type T50 couplings; speeds for Type T50 Floating Shaft couplings are shown in **Table 12, page 26**.

## How to Select

### Type T41 Controlled Torque Couplings & T44 Controlled Torque Clutches

#### Type T41 Controlled Torque Couplings

1. **Running Torque:** Calculate normal running torque.

$$\text{Running Torque (Nm)} = \frac{\text{Required kW} \times 9549}{\text{Rpm}}$$

2. **Slip Torque:** Slip torque = Running Torque x 150% (Overload Setting.) Rexnord recommends a minimum 150% overload setting for steady or moderate shock load applications. For heavy shock load applications, a 200% or greater overload setting may be required.
3. **Coupling Size:** Refer to **Table 8, page 17** — Trace down the Slip Torque column to a figure equal to or in excess of the calculated slip torque determined in Step 2. Read the coupling size in the next column.

4. **Check:**

- A. Check shaft diameters against coupling maximum bores shown in **Table 8, page 17**. If selection does not have adequate bore capacity, refer to **Table 14, page 34**, or **Table 16, page 35**, for maximum bores with square or rectangular keys, or select the next larger size coupling.
- B. Check the required speed against the allowable speed shown in **Table 8**. If a higher speed is required, refer application details to the local Rexnord representative.
- C. Check allowable slip torque times from Slip Torque Performance Charts on **pages 21-24**. The length of time a coupling can slip without exceeding its thermal capacity is a function of the slip torque setting and the operating speed. An automatic cutout switch, **page 20**, can be provided when damaging thermal conditions exist.
- D. Check application dimension requirements against selected coupling dimensions shown on **page 17**.
- E. Check usable shaft length to the coupling hub lengths on **page 15**. If necessary, overhang hubs within the limits specified on **page 20**.

#### Selection Example

Select a controlled torque coupling to connect a 15 kW, 1500 rpm, 160 L frame motor to the high-speed shaft of a gear drive driving a screw feeder. Motor shaft diameter is 42 mm with a usable shaft length of 110 mm. Drive high-speed shaft diameter is 35 mm with usable shaft length of 65 mm.

1. **Running Torque:** From Step 1 above:

$$\text{Running Torque (Nm)} = \frac{15 \text{ kW} \times 9549}{1500 \text{ Rpm}} = 95,5 \text{ Nm}$$

2. **Slip Torque:** From Step 2 above: Slip Torque = 95,5 x 150% = 143,2 Nm
3. **Size:** From **Table 8, page 17**, the Size 1040T41 has a maximum slip torque of 167 Nm.

4. **Check:**

- A. From **Table 8, page 17**, the Size 1040T41 (T41 hub) has maximum bore capacity of only 35 mm and the "T" hub maximum bore capacity is 43 mm. The preferred mounting arrangement is to have the T41 hub on the motor (for optimum cooling during slippage). Therefore, select the size 1050T41 with a maximum T41 hub bore of 45 mm.
- B. Allowable Speed of 3600 rpm exceeds required 1750 rpm.
- C. From **page 21**, the Size 1050T41 with slip torque setting of 143,2 Nm and running speed of 1500 rpm will permit 27 seconds slip if followed by 9 minutes of non-slip.
- D. See **page 17** for dimensions.
- E. Usable shaft length of motor is 110 mm and "W" dimension for T41 hub is 87,4 mm, therefore no overhang required. Usable shaft length of drive is 65 mm and "C" dimension of "T" hub is 60,5 mm, therefore no overhang required.

#### Type T44 Controlled Torque Clutches

1. **Running Torque**

$$\text{Running Torque (Nm)} = \frac{\text{Required kW} \times 9549}{\text{Rpm}}$$

2. **Slip Torque:** Slip Torque = Running Torque x 150% (Overload Setting.) Rexnord recommends a minimum 150% overload setting for steady or moderate shock load applications. For heavy shock load applications a 200% or greater overload setting may be required.
3. **Clutch Size:** Refer to **Table 9, page 18** — Trace down the Slip Torque column to a figure equal to or in excess of the calculated slip torque determined in Step 2. Read clutch size in the next column.
  - A. Check shaft diameters against clutch maximum bores shown in **Table 9**. If selection does not have adequate bore capacity, refer to **Table 16, page 35**, for maximum bores with square or rectangular keys, or select the next larger size clutch.
  - B. Check the required speed against the allowable speed shown in **Table 9**. If a higher speed is required, refer application details to the local Rexnord representative.
  - C. Check allowable slip torque times from Slip Torque Performance Charts on **pages 21-24**. The length of time a clutch can slip without exceeding its thermal capacity is a function of the slip torque setting and the operating speed. An automatic cutout switch, **page 20**, can be provided when damaging thermal conditions exist.
  - D. Check application dimension requirements against selected clutch dimensions shown on **page 18**.
  - E. Check usable shaft length to the clutch hub length on **page 18**. If necessary, overhang hub within the limits specified on **page 20**.



## Quick Selection Method

- C. Check the required speed against the allowable speed shown in **Table 1** for the type of coupling selected. For Type T50 Floating Shaft design, check the allowable speed from **Table 12** on **page 26**. If a higher speed is required, refer application details to the local Rexnord representative.
- D. Check application dimension requirements against selected coupling type dimensions shown on **pages 11-32**.

### Example:

Select a coupling to connect a 250 kW, 1170 rpm electric motor to the drive high-speed shaft of a maneuvering winch. The shaft gap is 3 to 4 mm. The motor shaft diameter is 180 mm and the drive shaft diameter is 160 mm. The motor and drive shaft extensions are each 152 mm long.

1. Select Coupling Type — To connect close-coupled shafts (3 to 4 mm gap), the Type T10 or T20 coupling is the proper selection. Type T10 is selected.
2. Determine Service Factor — From **Table 4**, the service factor is 1.5.
3. Determine Equivalent kW — From **Table 2**, the equivalent hp is 250 kW.
4. Select Coupling Size — (A) From **Table 3**, the coupling size is 1150T10. (B) From **Table 14**, the maximum bore with square key is 215 mm. (C) From **Table 1**, the allowable speed of a 1150T10 is 1550 rpm. (D) Dimensions for the 1150T10 coupling shown on **page 11** satisfies the application requirements.

**Table 3 — Coupling Selection ... Based on Equivalent kW Ratings (Continued)**

	1140T	1150T	1160T	1170T	1180T	1190T	1200T	1210T	1220T	1230T	1240T	1250T ②	1260T ②
Max Bore (mm)	200	215	240	280	300	335	360	390	420	450	480	②	②
Max Speed T10	1650 rpm	1500 rpm	1350 rpm	1225 rpm	1100 rpm	1050 rpm	900 rpm	820 rpm	730 rpm	680 rpm	630 rpm	580 rpm	540 rpm
Max Speed T20	2200 rpm	2000 rpm	1750 rpm	1600 rpm	—	—	—	—	—	—	—	—	—
Torque (Nm)	28585	39770	55930	74570	103400	136710	186430	248570	335570	435000	559300	745700	932100
kW / 100 rpm	2,99	4,16	5,86	7,81	10,8	14,3	19,5	26	35,1	45,6	58,6	78,1	97,6
rpm	kW Ratings												
4500	—	—	—	—	—	—	—	—	—	—	—	—	—
3600	—	—	—	—	—	—	—	—	—	—	—	—	—
3000	—	—	—	—	—	—	—	—	—	—	—	—	—
2500	—	—	—	—	—	—	—	—	—	—	—	—	—
2100	6300 ①	8760 ①	—	—	—	—	—	—	—	—	—	—	—
1800	5400 ①	7510 ①	10500 ①	—	—	—	—	—	—	—	—	—	—
1750	5250 ①	7300 ①	10200 ①	13700 ①	—	—	—	—	—	—	—	—	—
1450	4350	6050	8490 ①	11300 ①	—	—	—	—	—	—	—	—	—
1170	3510	4880	6850	9140	—	—	—	—	—	—	—	—	—
1000	3000	4170	5860	7810	10800	14300	—	—	—	—	—	—	—
870	2610	3630	5100	6790	9420	12500	17000	—	—	—	—	—	—
720	2160	3000	4220	5620	7800	10300	14100	18800	25300	—	—	—	—
650	1950	2710	3810	5080	7040	9310	12700	17000	22900	29600	—	—	—
580	1740	2420	3400	4530	6280	8300	11300	15100	20400	26400	33900	45300	—
520	1560	2170	3050	4060	5630	7440	10200	13600	18300	23700	30400	40600	50800
420	1260	1750	2460	3280	4550	6010	8200	11000	14800	19100	24600	32800	41000
350	1050	1460	2050	2730	3790	5010	6830	9140	12300	15900	20500	27300	34200
280	840	1170	1640	2190	3030	4010	5470	7310	9860	12800	16400	21900	27300
230	690	959	1350	1800	2490	3290	4490	6000	8100	10500	13500	18000	22500
190	570	792	1110	1480	2060	2720	3710	4960	6690	8660	11100	14800	18500
155	465	646	908	1210	1680	2220	3030	4050	5460	7060	9070	12100	15100
125	375	521	732	976	1350	1790	2440	3260	4400	5690	7310	9760	12200
100	300	417	586	781	1080	1430	1950	2610	3520	4560	5850	7810	9760
84	252	350	492	656	910	1200	1640	2190	2960	3830	4910	6560	8200
68	204	284	398	531	736	974	1330	1770	2390	3100	3980	5310	6640
56	168	234	328	437	606	802	1090	1460	1970	2550	3280	4370	5470
45	135	188	264	351	487	644	879	1170	1580	2050	2630	3510	4390
37	111	154	217	289	401	530	722	966	1300	1690	2160	2890	3610
30	90,0	125	176	234	325	429	586	783	1060	1370	1760	2340	2930
25	75,0	104	146	195	271	358	488	653	880	1140	1460	1950	2440
20	60,0	83	117	156	217	286	390	522	704	911	1170	1560	1950
16,5	49,5	68,8	97	129	179	236	322	431	581	752	965	1290	1610
13,5	40,5	56,3	79	105	146	193	264	352	475	615	790	1050	1320
11,0	33,0	45,9	64,4	85,9	119	157	215	287	387	501	644	859	1070
9,0	27,0	37,5	52,7	70,3	97	129	176	235	317	410	527	703	878
7,5	22,5	31,3	29,3	39,0	81	107	146	196	264	342	439	586	732
5,0	15,0	20,9	—	—	54	72	98	131	176	228	293	390	488

① Ratings apply to Type T20 only.

② Refer to Rexnord.



# Service Factors

**Table 4 — Flexible Coupling Service Factors for Motor ① and Turbine Drives**

Service factors listed are typical values based on normal operation of the drive systems.

Application	Service Factor	Application	Service Factor
<b>AERATOR</b> .....	2.0	<b>HAMMERMILL</b> .....	1.75
<b>AGITATORS</b>		<b>LAUNDRY WASHER OR TUMBLER</b> .....	2.0
Vertical and Horizontal		<b>LINE SHAFTS</b>	
Screw, Propeller, Paddle.....	1.0	Any Processing Machinery.....	1.5
<b>BARGE HAUL PULLER</b> .....	1.5	<b>MACHINE TOOLS</b>	
<b>BLOWERS</b>		Auxiliary and Traverse Drive.....	1.0
Centrifugal.....	1.0	Bending Roll, Notching Press, Punch Press,	
Lobe or Vane.....	1.25	Planer, Plate Reversing.....	1.75
<b>CAR DUMPERS</b> .....	2.5	Main Drive.....	1.5
<b>CAR PULLERS</b> .....	1.5	<b>MAN LIFTS</b> .....	<b>Not Approved</b>
<b>CLARIFIER OR CLASSIFIER</b> .....	1.0	<b>METAL FORMING MACHINES</b>	
<b>COMPRESSORS</b>		Continuous Caster.....	1.75
Centrifugal.....	1.0	Draw Bench Carriage and Main Drive.....	2.0
Rotary, Lobe or Vane.....	1.25	Extruder.....	2.0
Rotary, Screw.....	1.0	Farming Machine and Forming Mills.....	2.0
Reciprocating		Slitters.....	1.0
Direct Connected.....	Refer to Factory	Wire Drawing or Flattening.....	1.75
Without Flywheel.....	Refer to Factory	Wire Winder.....	1.5
② With Flywheel and Gear between Compressor		Coilers and Uncoilers.....	1.5
and Prime Mover		<b>MIXERS (see Agitators)</b>	
1 cylinder, single acting.....	3.0	Concrete.....	1.75
1 cylinder, double acting.....	3.0	Muller.....	1.5
2 cylinders, single acting.....	3.0	<b>PRESS, PRINTING</b> .....	1.5
2 cylinders, double acting.....	3.0	<b>PUG MILL</b> .....	1.75
3 cylinders, single acting.....	3.0	<b>PULVERIZERS</b>	
3 cylinders, double acting.....	2.0	Hammermill and Hog.....	1.75
4 or more cyl., single act.....	1.75	Roller.....	1.5
4 or more cyl., double act.....	1.75	<b>PUMPS</b>	
③ <b>CONVEYORS</b>		Boiler Feed.....	1.5
Apron, Assembly, Belt, Chain, Flight, Screw.....	1.25	Centrifugal — Constant Speed.....	1.0
Bucket.....	1.0	Frequent Speed Changes under Load.....	1.25
Live Roll, Shaker and Reciprocating.....	3.0	Descaling, with accumulators.....	1.25
③④ <b>CRANES AND HOIST</b>		Gear, Rotary, or Vane.....	1.25
Main Hoist.....	1.75 ③	Reciprocating, Plunger Piston	
Skip Hoist.....	1.75 ③	1 cyl., single or double act.....	3.0
Slope.....	1.5	2 cyl., single acting.....	2.0
Bridge, Travel or Trolley.....	1.75	2 cyl., double acting.....	1.75
<b>DYNAMOMETER</b> .....	1.0	3 or more cylinders.....	1.5
<b>ELEVATORS</b>		Screw Pump, Progressing Cavity.....	1.25
Bucket, Centrifugal Discharge.....	1.25	Vacuum Pump.....	1.25
Freight or Passenger.....	<b>Not Approved</b>	<b>SCREENS</b>	
Gravity Discharge.....	1.25	Air Washing.....	1.0
<b>ESCALATORS</b> .....	<b>Not Approved</b>	Grizzly.....	2.0
<b>EXCITER, GENERATOR</b> .....	1.0	Rotary Coal or Sand.....	1.5
<b>EXTRUDER, PLASTIC</b> .....	1.5	Vibrating.....	2.5
<b>FANS</b>		Water.....	1.0
Centrifugal.....	1.0	<b>SKI TOWS &amp; LIFTS</b> .....	<b>Not Approved</b>
Cooling Tower.....	2.0	<b>STEERING GEAR</b> .....	1.0
Forced Draft — Across the Line start.....	1.5	<b>STOKER</b> .....	1.0
Forced Draft Motor driven thru fluid		<b>TIRE SHREDDER</b> .....	1.50
or electric slip clutch.....	1.0	<b>TUMBLING BARREL</b> .....	1.75
Gas Recirculating.....	1.5	<b>WINCH, MANEUVERING</b>	
Induced Draft with damper control		Dredge, Marine.....	1.5
or blade cleaner.....	1.25	<b>WINDLASS</b> .....	1.5
Induced Draft without controls.....	2.0	<b>WOODWORKING MACHINERY</b> .....	1.0
<b>FEEDERS</b>		<b>WORK LIFT PLATFORMS</b> .....	<b>Not Approved</b>
Apron, Belt, Disc, Screw.....	1.0		
Reciprocating.....	2.5		
<b>GENERATORS</b>			
Even Load.....	1.0		
Hoist or Railway Service.....	1.5		
Welder Load.....	2.0		

- ① For engine drives, refer to **Table 5**. Electric motors, generators, engines, compressors and other machines fitted with sleeves or straight roller bearings usually require limited end float couplings. In doubt, provide axial clearances and centering forces to the Factory for a recommendation.
- ② For balanced opposed design, refer to the Factory.
- ③ If people are occasionally transported, refer to the Factory for the selection of the proper size coupling.
- ④ For high peak load applications (such as Metal Rolling Mills) refer to the Factory.

**Table 5 — Engine Drive Service Factors ⑤**

Service Factors (S. F.) for engine drives are those required for applications where good flywheel regulation prevents torque fluctuations greater than ±20%. For drives where torque fluctuations are greater or where the operation is near a serious critical or torsional vibration, a mass elastic study is necessary.







No. of Cylinders	4 or 5 ⑥				6 or more ①					
	1.0	1.25	1.5	1.75	2.0	1.0	1.25	1.5	1.75	2.0
<b>Table 4 S.F.</b>	1.0	1.25	1.5	1.75	2.0	1.0	1.25	1.5	1.75	2.0
<b>Engine S.F.</b>	2.0	2.25	2.5	2.75	3.0	1.5	1.75	2.0	2.25	2.5

- ⑤ To use **Table 5**, first determine application service factor from **Table 4**. Use that factor to determine Engine Service Factor from **Table 5**. When service factor from **Table 4** is greater than 2.0, or where 1, 2 or 3 cylinder engines are involved, refer complete application details to Rexnord Engineering.

Industry	Service Factor	Industry	Service Factor
<b>AGGREGATE PROCESSING, CEMENT, MINING KILNS; TUBE, ROD AND BALL MILLS</b>		Shear, Croppers.....	Refer to Factory
Direct or on L. S. shaft of Reducer,		Sideguards.....	3.0
with final drive Machined Spur Gears.....	2.0	Skeip Mills.....	Refer to Factory
Single Helical or Herringbone Gears.....	1.75	Slitters, Steel Mill only.....	1.75
Conveyors, Feeders, Screens,		Soaking Pit Cover Drives —	
Elevators.....	See General Listing	Lift.....	1.0
Crushers, Ore or Stone.....	2.5	Travel.....	2.0
Dryer, Rotary.....	1.75	Straighteners.....	2.0
Grizzly.....	2.0	Unscramblers (Billet Bundle Busters).....	2.0
Hammermill or Hog.....	1.75	Wire Drawing Machinery.....	1.75
Tumbling Mill or Barrel.....	1.75	<b>OIL INDUSTRY</b>	
<b>BREWING AND DISTILLING</b>		Chiller.....	1.25
Bottle and Can Filling Machines.....	1.0	Oilwell Pumping (not over 150% peak torque).....	2.0
Brew Kettle.....	1.0	Paraffin Filter Press.....	1.5
Cookers, Continuous Duty.....	1.25	Rotary Kiln.....	2.0
Lauter Tub.....	1.5	<b>PAPER MILLS</b>	
Mash Tub.....	1.25	Barker Auxiliary, Hydraulic.....	2.0
Scale Hopper, Frequent Peaks.....	1.75	Barker, Mechanical.....	2.0
<b>CLAY WORKING INDUSTRY</b>		Barking Drum	
Brick Press, Briquette Machine, Clay Working		L. S. shaft of reducer with final drive - Helical	
Machine, Pug Mill.....	1.75	or Herringbone Gear.....	2.0
<b>DREDGES</b>		Machined Spur Gear.....	2.5
Cable Reel.....	1.75	Cast Tooth Spur Gear.....	3.0
Conveyors.....	1.25	Beater & Pulper.....	1.75
Cutter head, Jig Drive.....	2.0	Bleachers, Coaters.....	1.0
Maneuvering Winch.....	1.5	Calender & Super Calender.....	1.75
Pumps (uniform load).....	1.5	Chipper.....	2.5
Screen Drive, Stacker.....	1.75	Converting Machine.....	1.25
Utility Winch.....	1.5	Couch.....	1.75
<b>FOOD INDUSTRY</b>		Cutter, Felt Whipper.....	2.0
Beet Slicer.....	1.75	Lyerder.....	1.75
Bottling, Can Filling Machine.....	1.0	Dryer.....	1.75
Cereal Cooker.....	1.25	Felt Stretcher.....	1.25
Dough Mixer, Meat Grinder.....	1.75	Foudrinier.....	1.75
<b>LUMBER</b>		Jordan.....	2.0
Band Resaw.....	1.5	Log Haul.....	2.0
Circular Resaw, Cut-off.....	1.75	Line Shaft.....	1.5
Edger, Head Rig, Hog.....	2.0	Press.....	1.75
Gang Saw (Reciprocating).....	Refer to Factory	Pulp Grinder.....	1.75
Log Haul.....	2.0	Reel, Rewinder, Winder.....	1.5
Planer.....	1.75	Stock Chest, Washer, Thickener.....	1.5
Rolls, Non-Reversing.....	1.25	Stock Pumps, Centrifugal	
Rolls, Reversing.....	2.0	Constant Speed.....	1.0
Sawdust Conveyor.....	1.25	Frequent Speed Changes Under Load.....	1.25
Slab Conveyor.....	1.75	Suction Roll.....	1.75
Sorting Table.....	1.5	Vacuum Pumps.....	1.25
Trimmer.....	1.75	<b>RUBBER INDUSTRY</b>	
④ <b>METAL ROLLING MILLS</b>		Calender.....	2.0
Coilers (Up or Down) Cold Mills only.....	1.5	Cracker, Plasticator.....	2.5
Coilers (Up or Down) Hot Mills only.....	2.0	Extruder.....	1.75
Coke Plants		Intensive or Banbury Mixer.....	2.5
Pusher Ram Drive.....	2.5	Mixing Mill, Refiner or Sheeter	
Door Opener.....	2.0	One or two in line.....	2.5
Pusher or Larry Car Traction Drive.....	3.0	Three or four in line.....	2.0
Continuous Caster.....	1.75	Five or more in line.....	1.75
Cold Mills — Strip Mills.....	Refer to Factory	Tire Building Machine.....	2.5
Temper Mills.....	Refer to Factory	Tire & Tube Press Opener (Peak Torque).....	1.0
Cooling Beds.....	1.5	Tuber, Strainer, Pelletizer.....	1.75
Drawbench.....	2.0	Warming Mill	
Feed Rolls - Blooming Mills.....	3.0	One or two Mills in line.....	2.0
Furnace Pushers.....	2.0	Three or more Mills in line.....	1.75
Hot and Cold Saws.....	2.0	Washer.....	2.5
Hot Mills —		<b>SEWAGE DISPOSAL EQUIPMENT</b>	
Strip or Sheet Mills.....	Refer to Factory	Bar Screen, Chemical Feeders, Collectors,	
Reversing Blooming.....	Refer to Factory	Dewatering Screen, Grit Collector.....	1.0
Stabbing Mills.....	Refer to Factory	<b>SUGAR INDUSTRY</b>	
Edger Drives.....	Refer to Factory	Cane Carrier & Leveler.....	1.75
Ingot Cars.....	2.0	Cane Knife & Crusher.....	2.0
Manipulators.....	3.0	Mill Stands, Turbine Driver with all Helical	
Merchant Mills.....	Refer to Factory	or Herringbone gears.....	1.5
Mill Tables		Electric Drive or Steam Engine Drive with Helical,	
Roughing Breakdown Mills.....	3.0	Herringbone, or Spur Gears	
Hot Bed or Transfer, non-reversing.....	1.5	with any Prime Mover.....	1.75
Runout, reversing.....	3.0	<b>TEXTILE INDUSTRY</b>	
Runout, non-reversing, non-plugging.....	2.0	Batcher.....	1.25
Reel Drives.....	1.75	Calender, Card Machine.....	1.5
Rod Mills.....	Refer to Factory	Cloth Finishing Machine.....	1.5
Screwdown.....	2.0	Dry Can, Loom.....	1.5
Seamless Tube Mills		Dyeing Machinery.....	1.25
Piercer.....	3.0	Knitting Machine.....	Refer to Factory
Thrust Block.....	2.0	Mangle, Napper, Soaper.....	1.25
Tube Conveyor Rolls.....	2.0	Spinner, Tenter Frame, Winder.....	1.5
Reeler.....	2.0		
Kick Out.....	2.0		

## Service Factors

**SERVICE FACTORS** are a guide, based on experience, of the ratio between coupling catalog rating and system characteristics. The system characteristics are best measured with a torque meter.

Torque Demands Driven Machine	Typical applications for electric motor or turbine driven equipment	Typical Service Factor
	Constant torque such as Centrifugal Pumps, Blowers and Compressors.	1.0
	Continuous duty with some torque variations including Plastic Extruders, Forced Draft Fans.	1.5
	Light shock loads from Metal Extruders, Cooling Towers, Cane Knife, Log Haul.	2.0
	Moderate shock loading as expected from a Car Dumper, Stone Crusher, Vibrating Screen.	2.5
	Heavy shock load with some negative torques from Roughing Mills, Reciprocating Pumps, Compressors, Reversing Runout Tables.	3.0
	Applications like Reciprocating Compressors with frequent torque reversals, which do not necessarily cause reverse rotations.	Refer to Factory

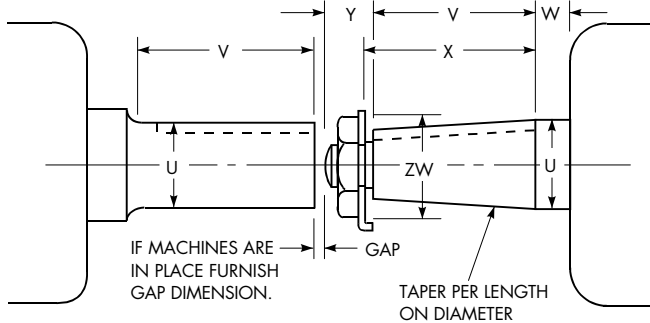

## Products

### General Information

- Rexnord standards apply unless otherwise specified.
- All dimensions are for reference only and are subject to change without notice unless certified.
- Unless otherwise specified, Falk coupling hub Sizes 1020 thru 1090 will be bored for clearance fit with a setscrew over the keyway. Sizes 1100 and larger will be furnished for interference fit without a setscrew (see **Table 27, page 40**). Recommended key sizes for the listed maximum bores are shown in **Table 26 on page 40**.
- Torque ratings of couplings utilizing Taper-Lock bushings can differ from those that do not. Refer to Rexnord for details.
- If Factory is to supply coupling hubs bored for Taper-Lock bushings, the bushing manufacturer **MUST** be noted on the order.
- Consult Rexnord when limited end float is required or application temperature exceeds 121°C.

## How to Order

The following information is necessary to quote or ship to your exact requirements. Prompt service is assured if this information is given on your inquiry or order.

1. Application: Driver & Driven
2. Power: Normal kW, Maximum kW or Torque (Nm)
3. Speed (rpm)
4. For Type T63 Disc Brake Couplings, furnish brake requirements.
  - A. Holding torque requirement.
  - B.  $WR^2$  of rotating parts (at brake location).
  - C. Frequency of stops.
  - D. Rate of deceleration required — desired stop time and stopping rpm.
5. Quantity
6. Coupling Size and Type e.g., 110T41 or 1070T10
7. Shaft Gap or distance between shaft ends (BE Dimension)
8. Bore Sizes: Must specify clearance or interference fit, or fit will be furnished per **Table 27, page 40**. Bore sizes will be furnished as per **Table 28 on page 40** or **Table 30 on pages 41 and 42** unless specified differently.
9. Shaft Dimensions as follows:

### For Straight Shafts:

Driving Shaft	Driven Shaft
Diameter U _____	Diameter U _____
Tolerance _____	Tolerance _____
Length V _____	Length V _____
Keyway _____	Keyway _____

**NOTE:** Provide shaft tolerances if different than those shown in **Table 27 through Table 30, pages 40-42**. Unless otherwise specified, keyway sizes in inch shafts will be furnished based on key sizes listed in **Table 26, page 40**, to Rexnord tolerances; metric keyways will be furnished for keys listed in **Table 26, page 40** per ISO/R773-1969 (ANSI/AGMA 9112) and Js9 width tolerances. For other shaft/bore requirements, consult Rexnord.

### For Taper Shafts: keyway is assumed to be parallel to the bore.

Diameter U _____	Across Flats _____
Length V _____	Corners ZW _____
Length W _____	Taper _____
Length X _____	Keyway _____
Length Y _____	

### Factory Warranty

We're so confident in the performance and reliability of our latest generation of Falk and Rexnord® gear drives that we're backing this comprehensive offering with the best standard warranty in the business. Our full, 3-year Heavy-Duty Warranty provides "shaft-to-shaft" protection on all Falk components — including bearings and seals. It's an industry first ... and one more powerful reason why Rexnord is your ultimate bottom-line drive and coupling value. ① Steelflex grid couplings are warranted for 5 Years when lubricated with Falk Long Term Grease (LTG).

- ① Warranty extends for 3 years from date of shipment. Does not apply to Falk Omnibox®, Ultramite®, Fluid Couplings, RENEW® and spare parts. Warranty applies to Steelflex and Lifelign® couplings with the use of Falk LTG.

# Close-Coupled Type T10

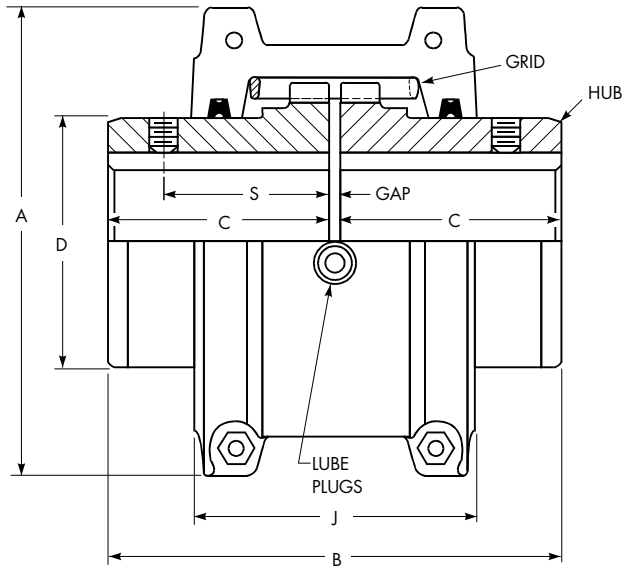

## COVER PROFILES – HORIZONTAL SPLIT

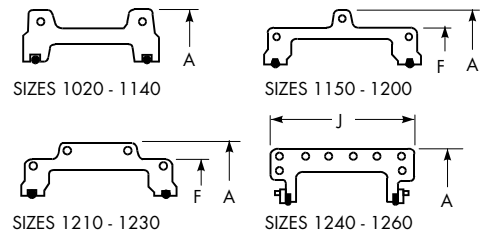

Sizes 1020 thru 1230T10 covers are cast aluminum alloy;  
 Sizes 1240 thru 1260T10 are fabricated steel.

### Dimensions (mm)

Size ①	Torque Rating (Nm) ②	Allow Speed RPM ③	Max Bore (mm) ④	Min Bore (mm) ⑤	Cplg Wt with No Bore (kg)	Lube Wt (kg)	A	B	C	D	F	J	S	GAP
1020T	52	4500	28	13	1,92	0,0272	97,0	98,2	47,6	39,7	–	66,7	39,1	3
1030T	149	4500	35	13	2,58	0,0408	105,7	98,2	47,6	49,2	–	68,3	39,1	3
1040T	249	4500	43	13	3,34	0,0544	114,3	104,6	50,8	57,2	–	69,9	40,1	3
1050T	435	4500	50	13	5,44	0,068	135,1	123,6	60,3	66,7	–	80,9	44,7	3
1060T	684	4350	56	20	7,44	0,0862	147,8	130,0	63,5	76,2	–	93,5	52,3	3
1070T	994	4125	67	20	10,4	0,113	158,8	155,4	76,2	87,3	–	96,8	53,8	3
1080T	2 050	3600	80	27	17,9	0,172	190,5	180,8	88,9	104,8	–	115,6	64,5	3
1090T	3 730	3600	95	27	25,6	0,254	211,1	199,8	98,4	123,8	–	122,2	71,6	3
1100T	6 280	2440	110	42	42,0	0,426	251,0	246,2	120,6	142,1	–	155,4	–	5
1110T	9 320	2250	120	42	54,3	0,508	269,7	259,0	127,0	160,3	–	161,5	–	5
1120T	13 700	2025	140	61	81,2	0,735	307,8	304,4	149,2	179,4	–	191,5	–	6
1130T	19 900	1800	170	67	121	0,907	345,9	329,8	161,9	217,5	–	195,1	–	6
1140T	28 600	1650	200	67	178	1,13	384,0	374,4	184,2	254,0	–	201,2	–	6
1150T	39 800	1500	215	108	234	1,95	453,1	371,8	182,9	269,2	391,2	271,5	–	6
1160T	55 900	1350	240	121	317	2,81	501,9	402,2	198,1	304,8	436,9	278,4	–	6
1170T	74 600	1225	280	134	448	3,49	566,9	437,8	215,9	355,6	487,2	307,3	–	6
1180T	103 000	1100	300	153	619	3,76	629,9	483,6	238,8	393,7	554,7	321,1	–	6
1190T	137 000	1050	335	153	776	4,4	675,6	524,2	259,1	436,9	607,8	325,1	–	6
1200T	186 000	900	360	178	1058	5,62	756,9	564,8	279,4	497,8	660,4	355,6	–	6
1210T	249 000	820	390	178	1424	10,5	844,6	622,6	304,8	533,4	750,8	431,8	–	13
1220T	336 000	730	420	203	1785	16,1	920,8	663,2	325,1	571,5	822,2	490,2	–	13
1230T	435 000	680	450	203	2267	24,0	1003,3	703,8	345,4	609,6	904,7	546,1	–	13
1240T	559 000	630	480	254	2950	33,8	1087,1	749,6	368,3	647,7	–	647,7	–	13
1250T	746 000	580	⑥	254	3833	50,1	1181,1	815,6	401,3	711,2	–	698,5	–	13
1260T	932 000	540	⑥	254	4682	67,2	1260,9	876,6	431,8	762,0	–	762,0	–	13

- ① Refer to page 10 for General Information.
- ② Peak torque capacity is two times the published rating. Torque ratings for hubs with Taper-Lock® bushings differ from those shown, refer to Table 18, page 36.
- ③ Consult Factory for higher speeds.
- ④ Maximum bores are reduced for hubs furnished with an interference fit and a setscrew over the keyway. Refer to Rexnord Engineering Sheet 427-105 for details.
- ⑤ Minimum bore is the smallest bore to which a Rough Stock Bore (RSB) hub can be bored. Depending upon coupling size, RSB hubs may have only a blind centering hole or a through hole that will permit remachining of the hubs to the minimum bores specified.
- ⑥ Refer to Rexnord.

## Close-Coupled Type T20

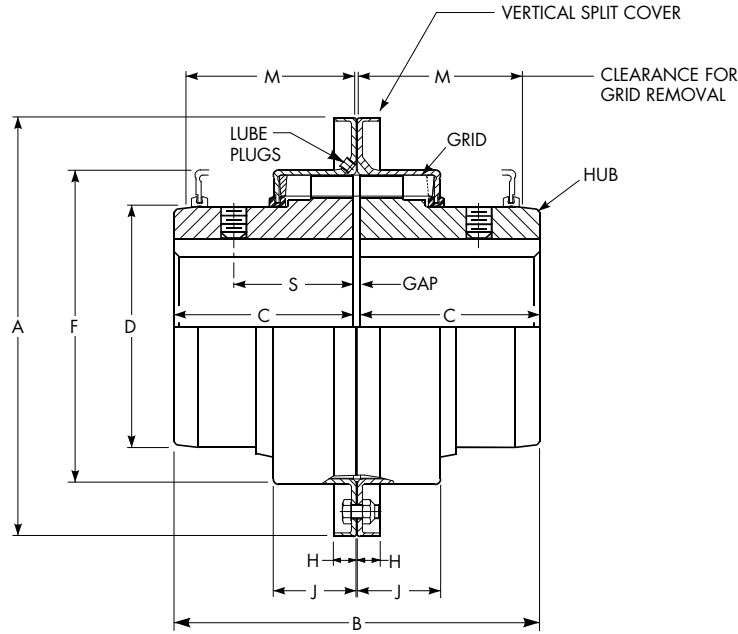

### Dimensions (mm)

Size ①	Torque Rating (Nm) ③	Allow Speed RPM ④	Max Bore (mm) ⑤	Min Bore (mm) ⑥	Cplg Wt w/o Bore (kg)	Lube Wt (kg)	A	B	C	D	F	H	J	M	S	GAP
1020T	52	6000	28	13	1,94	0,0272	112,3	98,2	47,6	39,7	64,3	9,7	23,9	47,8	39,1	3
1030T	149	6000	35	13	2,58	0,0408	121,8	98,2	47,6	49,2	73,8	9,7	24,9	47,8	39,1	3
1040T	249	6000	43	13	3,35	0,0544	129,8	104,6	50,8	57,2	81,8	9,7	25,9	50,8	40,1	3
1050T	435	6000	50	13	5,32	0,068	148,8	123,6	60,3	66,7	97,6	11,9	30,5	60,5	44,7	3
1060T	684	6000	56	20	7,01	0,0862	163,1	130,0	63,5	76,2	111,1	12,7	31,8	63,5	52,3	3
1070T	994	5500	67	20	10,2	0,113	174,2	155,4	76,2	87,3	122,3	12,7	33,0	66,5	53,8	3
1080T	2 050	4750	80	27	17,6	0,172	201,2	180,8	88,9	104,8	149,2	12,7	43,7	88,9	64,5	3
1090T	3 730	4000	95	27	25,4	0,254	232,9	199,8	98,4	123,8	168,3	12,7	47,0	95,2	71,6	3
1100T	6 280	3600	110	42	42,0	0,426	267,9	246,2	120,6	142,1	198,0	15,7	59,7	120,7	–	5
1110T	9 320	3000	120	42	54,4	0,508	286,9	259,0	127,0	160,3	216,3	16,0	62,7	124,0	–	5
1120T	13 700	2700	140	61	81,8	0,735	320,2	304,4	149,2	179,4	245,5	17,5	73,7	142,7	–	6
1130T	19 900	2400	170	67	122	0,907	379,0	329,8	161,9	217,5	283,8	20,6	74,9	146,0	–	6
1140T	28 600	2200	200	67	180	1,13	417,1	374,4	184,2	254,0	321,9	20,6	78,2	155,4	–	6
1150T	39 800	2000	215	108	230	1,95	476,2	371,8	182,9	269,2	374,4	19,3 ②	107,3	203,2	–	6
1160T	55 900	1750	240	121	321	2,81	533,4	402,2	198,1	304,8	423,9	30,0 ②	115,3	215,9	–	6
1170T	74 600	1600	280	134	448	3,49	584,2	437,8	215,9	355,6	474,7	30,0 ②	120,1	226,1	–	6

① Refer to **page 10** for General Information.

② Dimension "H" is to the end of the bolt on Sizes 1150 thru 1170. Bolts are not shrouded.

③ Peak torque capacity is two times the published rating. Torque ratings for hubs with Taper-Lock bushings differ from those shown, refer to **Table 18, page 36**.

④ Consult Factory for higher speeds.

⑤ Maximum bores are reduced for hubs furnished with an interference fit and a setscrew over the keyway. Refer to Rexnord Engineering Sheet 427-105 for details.

⑥ Minimum bore is the smallest bore to which a Rough Stock Bore (RSB) hub can be bored. Depending upon coupling size, RSB hubs may have only a blind centering hole or a through hole that will permit remachining of the hubs to the minimum bores specified.

# Full Spacer Type T31

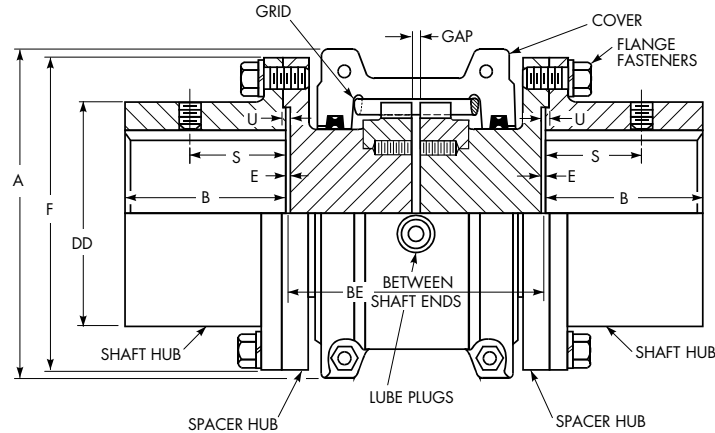

## Dimensions (mm)

Size ①	Torque Rating (Nm) ②	Allow Speed RPM ③	Max Bore (mm) ④	Min Bore (mm) ⑤	Cplg Wt with No Bore & Min BE (kg)	Wt Added per mm of BE over Min	Lube Wt (kg)	A	B	BE		DD	E	F	S	U	GAP	Flange Fasteners	
										Min	Max							No. per Flange & SAE Grade	Dia (in)
1020T	52	4500	35	13	3,85	0,01	0,0272	97,0	34,9	88,9	203	52,4	0,8	85,7	27,4	1,8	5	4- GR 8	0.250
1030T	149	4500	43	13	5,21	0,016	0,0408	105,7	41,3	88,9	216	59,5	0,8	93,7	31,5	1,8	5	8- GR 8	0.250
1040T	249	4500	56	13	8,43	0,021	0,0544	114,3	54,0	88,9	216	78,6	0,8	112,7	27,4	1,8	5	8- GR 8	0.250
1050T	435	4500	67	13	12,8	0,028	0,068	135,1	60,3	111,1	216	87,3	0,8	125,4	40,6	1,8	5	8- GR 8	0.312
1060T	684	4350	80	20	20,5	0,037	0,0862	147,8	73,0	122,2	330	103,2	1,8	144,5	43,2	2,8	5	8- GR 8	0.375
1070T	994	4125	85	20	24,8	0,048	0,113	158,8	79,4	127,0	330	109,5	1,8	152,4	46,7	2,8	5	12- GR 8	0.375
1080T	2 050	3600	95	27	40	0,069	0,172	190,5	88,9	155,5	406	122,2	1,8	177,8	49,8	2,8	5	12- GR 5	0.500
1090T	3 730	3600	110	27	60,1	0,1	0,254	211,1	101,6	163,5	406	142,9	1,8	209,6	56,9	2,8	5	12- GR 5	0.625
1100T	6 280	2440	130	39	90,2	0,12	0,426	251,0	90,4	203,2	406	171,4	1,6	250,8	-	3,2	6	12- GR 5	0.750
1110T	9 320	2250	150	51	119	0,16	0,508	269,7	104,1	209,6	406	196,8	1,6	276,2	-	3,2	6	12- GR 5	0.750
1120T	13 700	2025	170	64	178	0,2	0,735	307,8	119,4	246,1	406	225,4	1,6	319,1	-	4	10	12- GR 5	0.875
1130T	19 900	1800	190	77	237	0,29	0,907	345,9	134,6	257,1	406	238,1	1,6	346,1	-	4	10	12- GR 5	1.000
1140T	28 600	1650	210	89	327	0,4	1,13	384,0	152,4	266,7	406	266,7	1,6	385,8	-	4	10	12- GR 5	1.125

- ① Refer to **page 10** for General Information.
- ② Peak torque capacity is two times the published rating. Torque ratings for hubs with bushings differ from those shown, refer to **Table 18, page 36**.
- ③ Consult Factory for higher speeds.
- ④ Maximum bores are reduced for hubs furnished with an interference fit and a setscrew over the keyway. Refer to Rexnord Engineering Sheet 427-105 for details.
- ⑤ Minimum bore is the smallest bore to which a Rough Stock Bore (RSB) hub can be bored. Depending upon coupling size, RSB hubs may have only a blind centering hole or a through hole that will permit remachining of the hubs to the minimum bores specified.

**Table 6 — Type T31 Standard Stock Spacer Lengths (BE=Distance Between Shaft Ends)**

Between Shaft Ends			Coupling Size										
(in)	(mm)	Pump Std	1020T	1030T	1040T	1050T	1060T	1070T	1080T	1090T	1100T	1110T	
3.50	89	ANSI	X	X	X	-	-	-	-	-	-	-	
3.94	100	ISO	X	X	X	-	-	-	-	-	-	-	
4.25	108	MISC	X	X	X	-	-	-	-	-	-	-	
4.38	111	ANSI	X	X	X	X	-	-	-	-	-	-	
4.69	119	MISC	X	X	X	X	-	-	-	-	-	-	
5.00	127	ANSI	X	X	X	X	X	X	-	-	-	-	
5.22	133	MISC	-	-	X	X	-	-	-	-	-	-	
5.38	137	MISC	-	X	X	-	-	-	-	-	-	-	
5.51	140	ISO	X	X	X	X	X	X	-	-	-	-	
5.66	144	MISC	-	X	X	-	-	-	-	-	-	-	
5.81	148	MISC	-	X	X	X	-	-	-	-	-	-	
5.97	152	MISC	-	-	X	X	-	-	-	-	-	-	
6.12	155	MISC	-	X	X	X	X	X	-	-	-	-	
6.94	176	MISC	X	X	X	X	X	-	-	-	-	-	
7.00	178	ANSI	-	-	-	-	-	X	X	-	-	-	
7.09	180	ISO	-	-	X	X	-	X	X	X	-	-	
7.25	184	ANSI	-	X	X	X	X	X	X	X	-	-	
8.00	203	MISC	-	-	-	-	-	-	-	-	X	-	
8.59	218	MISC	-	-	-	-	-	-	X	-	-	-	
8.62	219	MISC	-	-	-	-	X	X	-	-	-	-	
8.88	226	MISC	-	-	-	-	-	-	-	-	X	-	
9.75	248	ANSI	-	-	-	-	X	X	X	X	X	X	
9.84	250	ISO	-	-	-	-	-	-	-	-	X	X	
9.94	252	MISC	-	-	-	-	-	-	X	-	-	-	
11.09	282	MISC	-	-	-	-	-	-	X	-	-	-	
12.25	311	ANSI	-	-	-	-	X	X	X	X	-	-	
14.05	357	MISC	-	-	-	-	-	-	-	-	-	X	

# Full Spacer Type T31

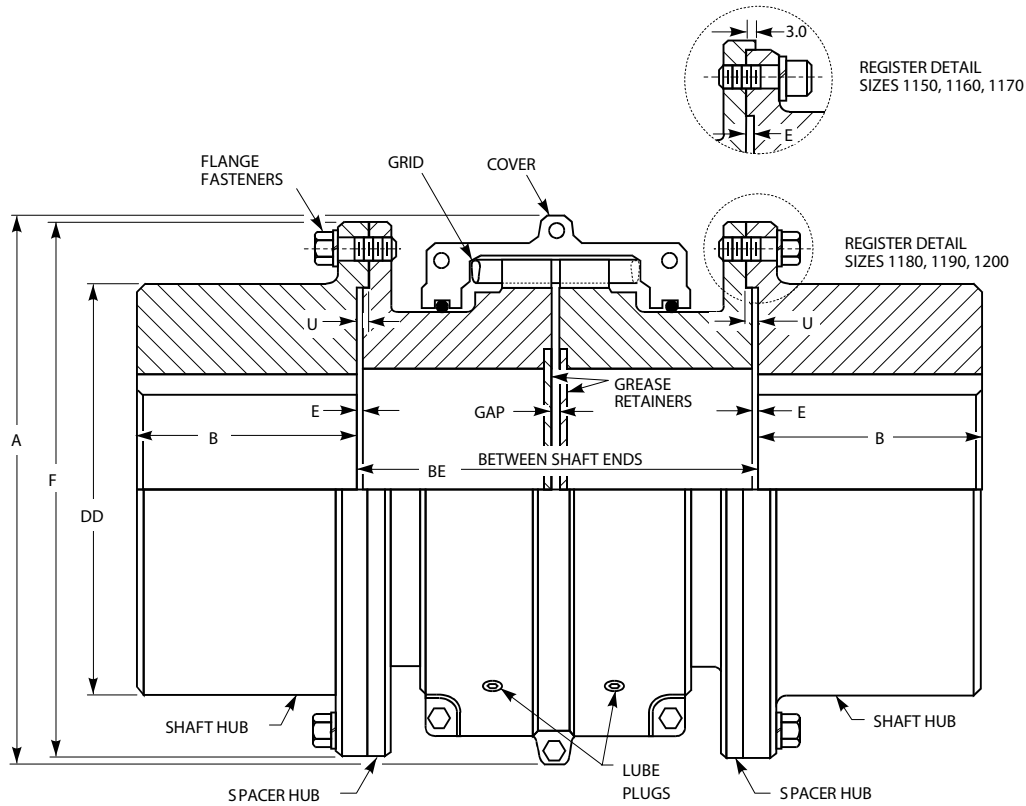

## Dimensions (mm)

Size ①	G52 Rigid Hub Size ③	Torque Rating (Nm) ④	Allow Speed RPM ⑤	Max Bore (mm) ⑥	Min Bore (mm) ⑦	Cplg Wt with No Bore & Min BE (kg)	Wt Added per mm of BE over Min	Lube Wt (kg)	A	B	BE		DD ②	E	F	U	GAP	Flange Fasteners	
											Min	Max						No. per Flange & SAE Grade	Dia (in)
1150T	1055G	39 800	1500	270	102	462	0,19	1,95	453,1	172,7	344,5	371,3	334,3	5,1	425,4	–	10	14- GR 8	0.875
1160T	1060G	55 900	1350	290	115	566	0,25	2,81	501,9	186,4	355,6	406,4	366,0	6,6	457,2	–	10	14- GR 8	0.875
1170T	1070G	74 600	1225	340	127	856	0,38	3,49	566,9	220,2	384,2	444,5	424,9	8,4	527,0	–	10	16- GR 8	1.000
1180T	1080G	103 000	1100	340	102	1135	0,47	3,76	629,9	248,9	400,1	490,5	450,8	5,1	590,6	8,1	10	16- GR 5	1.125
1190T	1090G	137 000	1050	380	115	1525	0,60	4,40	675,6	275,8	411,2	530,4	508,0	5,1	660,4	8,1	10	18- GR 5	1.250
1200T	1100G	186 000	900	400	127	1910	0,85	5,62	756,9	305,3	444,5	574,5	530,4	6,1	711,2	9,1	10	18- GR 5	1.250

① Refer to **page 10** for General Information.

② Dimension DD is for an as-cast, unmachined surface for Sizes 1180, 1190 and 1200T.

③ Type T31 couplings shown use Type G52 gear coupling rigid hubs as the shaft hubs.

④ Peak torque capacity is two times the published rating. Torque ratings for hubs with bushings differ from those shown, refer to **Table 18, page 36**.

⑤ Consult Factory for higher speeds.

⑥ Maximum bores are reduced for hubs furnished with an interference fit and a setscrew over the keyway. Refer to Rexnord Engineering Sheet 427-105 for details.

⑦ Minimum bore is the smallest bore to which a Rough Stock Bore (RSB) hub can be bored. Depending upon coupling size, RSB hubs may have only a blind centering hole or a through hole that will permit remachining of the hubs to the minimum bores specified.

# Half Spacer Type T35

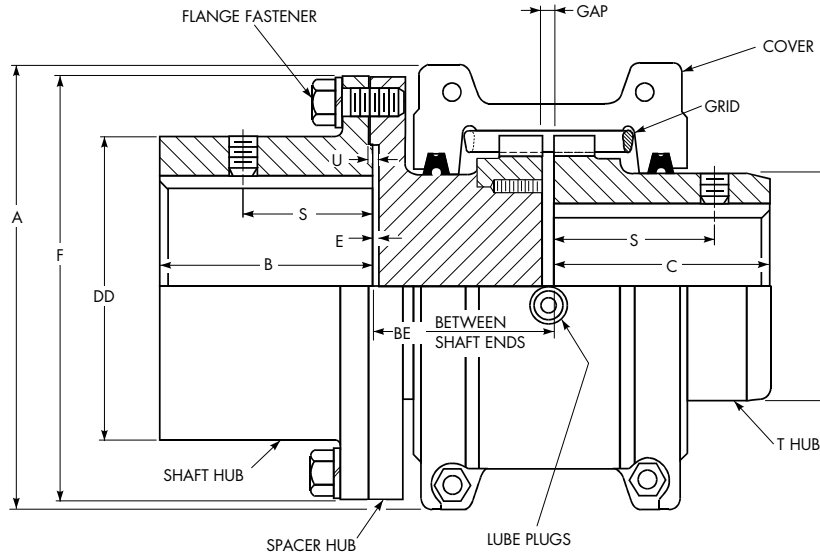

## Dimensions (mm)

Size ①	Torque Rating (Nm) ③	Allow Speed RPM ④	Max Bore (mm) ⑤		Min Bore (mm) ⑥	Cplg Wt with No Bore & Min BE (kg)	Wt Added per mm of BE over Min	Lube Wt (kg)	A	B	BE		C	D	DD	E	F	S		U	GAP	Flange Fasteners	
			Shaft Hub	T Hub							Min	Max						Shaft Hub	T Hub			No. per Flange & SAE Grade	Dia (in)
1020T	52	4500	35	28	13	2,89	0,01	0,0272	97,0	34,9	45,2	102	47,6	39,7	52,4	0,8	85,7	27,4	39,1	1,8	3	4- GR 8	0.250
1030T	149	4500	43	35	13	3,89	0,016	0,0408	105,7	41,3	45,2	109	47,6	49,2	59,5	0,8	93,7	31,5	39,1	1,8	3	8- GR 8	0.250
1040T	249	4500	56	43	13	5,88	0,021	0,0544	114,3	54,0	45,2	109	50,8	57,2	78,6	0,8	112,7	27,4	40,1	1,8	3	8- GR 8	0.250
1050T	435	4500	67	50	13	9,12	0,028	0,068	135,1	60,3	56,3	109	60,3	66,7	87,3	0,8	125,4	40,6	44,7	1,8	3	8- GR 8	0.312
1060T	684	4350	80	56	20	13,9	0,037	0,0862	147,8	73,0	61,9	166	63,5	76,2	103,2	1,8	144,5	43,2	52,3	2,8	3	8- GR 8	0.375
1070T	994	4125	85	67	20	17,6	0,048	0,113	158,8	79,4	64,3	166	76,2	87,3	109,5	1,8	152,4	46,7	53,8	2,8	3	12- GR 8	0.375
1080T	2 050	3600	95	80	27	28,9	0,069	0,172	190,5	88,9	78,6	204	88,9	104,8	122,2	1,8	177,8	49,8	64,5	2,8	3	12- GR 5	0.500
1090T	3 730	3600	110	95	27	42,8	0,10	0,254	211,1	101,6	82,6	204	98,4	123,8	142,9	1,8	209,6	56,9	71,6	2,8	3	12- GR 5	0.625
1100T	6 280	2440	130	110	39	66,1	0,12	0,426	251,0	90,4	103,2	205	120,6	142,1	171,4	1,6	250,8	-	-	3,2	5	12- GR 5	0.750
1110T	9 320	2250	150	120	51	84,6	0,16	0,508	269,7	104,1	106,4	205	127,0	160,3	196,8	1,6	276,2	-	-	3,2	5	12- GR 5	0.750
1120T	13 700	2025	170	140	64	129	0,20	0,735	307,8	119,4	124,6	205	149,2	179,4	225,4	1,6	319,1	-	-	4	6	12- GR 5	0.875
1130T	19 900	1800	190	170	77	179	0,29	0,907	345,9	134,6	130,1	205	161,9	217,5	238,1	1,6	346,1	-	-	4	6	12- GR 5	1.000
1140T	28 600	1650	210	200	89	252	0,40	1,13	384,0	152,4	134,9	205	184,2	254,0	266,7	1,6	385,8	-	-	4	6	12- GR 5	1.125

Table 7 — Type T35 Half Spacer Coupling Standard Stock Spacer Lengths

Between Shaft Ends		Pump Std	Coupling Size ②									
(in)	(mm)		1020T	1030T	1040T	1050T	1060T	1070T	1080T	1090T	1100T	1110T
1.78	45	MISC	X	X	X	-	-	-	-	-	-	-
2.22	56	MISC	X	X	X	X	-	-	-	-	-	-
2.53	64	MISC	X	X	X	X	X	X	-	-	-	-
2.79	71	MISC	X	X	X	X	X	X	-	-	-	-
3.50	89	ANSI	X	X	X	X	X	-	-	-	-	-
3.53	90	MISC	-	-	-	-	-	X	X	-	-	-
3.66	93	MISC	-	X	X	X	X	X	X	X	-	-
3.58	91	MISC	-	-	-	-	-	X	X	X	-	-
4.06	103	MISC	-	-	-	-	-	-	-	-	X	-
4.94	125	MISC	-	-	-	-	-	-	-	-	X	X
5.00	127	ANSI	-	-	-	-	-	-	X	-	X	X
5.51	140	ISO	-	-	-	-	-	-	X	X	X	-
6.16	156	MISC	-	-	-	-	X	X	X	X	-	-
6.19	157	MISC	-	-	-	-	-	-	-	-	X	-
7.09	180	ISO	-	-	-	-	-	-	-	X	-	X

① Refer to page 10 for General Information.

② **CAUTION:** To permit removal of T35 shaft hub without moving connected equipment, select a half spacer with dimension BE (in Table 7) greater than dimension B (in uppermost table) or overhang the shaft hub. Refer to Falk for maximum overhang allowed.

③ Peak torque capacity is two times the published rating. Torque ratings for hubs with bushings differ from those shown, refer to Table 18, page 36.

④ Consult Factory for higher speeds.

⑤ Maximum bores are reduced for hubs furnished with an interference fit and a setscrew over the keyway. Refer to Rexnord Engineering Sheet 427-105 for details.

⑥ Minimum bore is the smallest bore to which a Rough Stock Bore (RSB) hub can be bored. Depending upon coupling size, RSB hubs may have only a blind centering hole or a through hole that will permit remachining of the hubs to the minimum bores specified.

# Half Spacer Type T35

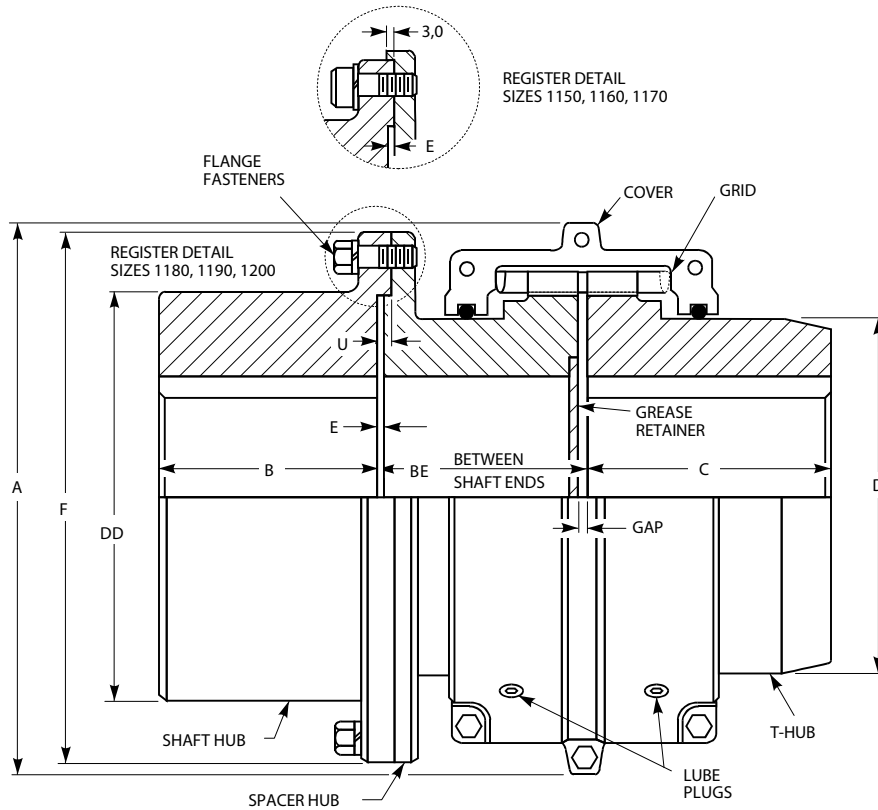

## Dimensions (mm)

Size ①	G52 Rigid Hub Size ③	Torque Rating (Nm) ④	Allow Speed RPM ⑤	Hub Bores				Cplg Wt with No Bore & Min BE (kg)	Wt Added per mm of BE over Min	Lube Wt (kg)	A	B	BE		C	D	DD ②	E	F	U	GAP	Flange Fasteners	
				Shaft Hub ③		T Hub							Min	Max								No. per Flange & SAE Grade	Dia (in)
				Max ⑥	Min ⑦	Max ⑥	Min ⑦																
1150T	1055G	39 800	1500	270	102	215	108	348	0,19	1,95	453,1	172,7	174,5	187,5	182,9	269,2	334,3	5,1	425,4	—	6	14- GR 8	0.875
1160T	1060G	55 900	1350	290	115	240	121	441	0,25	2,81	501,9	186,4	179,6	204,7	198,1	304,8	366,0	6,6	457,2	—	6	14- GR 8	0.875
1170T	1070G	74 600	1225	340	127	280	134	652	0,38	3,49	566,9	220,2	194,0	223,8	215,9	355,6	424,9	8,4	527,0	—	6	16- GR 8	1.000
1180T	1080G	103 000	1100	340	102	300	153	877	0,47	3,76	629,9	248,9	201,7	246,9	238,8	393,7	450,8	5,1	590,6	8,1	6	16- GR 5	1.125
1190T	1090G	137 000	1050	380	115	335	153	1150	0,60	4,40	675,6	275,8	207,3	266,7	259,1	436,9	508,0	5,1	660,4	8,1	6	18- GR 5	1.250
1200T	1100G	186 000	900	400	127	360	178	1484	0,85	5,62	756,9	305,3	223,8	289,1	279,4	497,8	530,4	6,1	711,2	9,1	6	18- GR 5	1.250

- ① Refer to **page 10** for General Information.
- ② Dimension DD is for an as-cast, unmachined surface for Sizes 1180, 1190 and 1200T.
- ③ Type T35 couplings shown use Type G52 gear coupling rigid hubs as the shaft hubs.
- ④ Peak torque capacity is two times the published rating. Torque ratings for hubs with bushings differ from those shown, refer to **Table 18, page 36**.
- ⑤ Consult Factory for higher speeds.
- ⑥ Maximum bores are reduced for hubs furnished with an interference fit and a setscrew over the keyway. Refer to Rexnord Engineering Sheet 427-105 for details.
- ⑦ Minimum bore is the smallest bore to which a Rough Stock Bore (RSB) hub can be bored. Depending upon coupling size, RSB hubs may have only a blind centering hole or a through hole that will permit remachining of the hubs to the minimum bores specified.



# Controlled Torque Types T41, T41-2

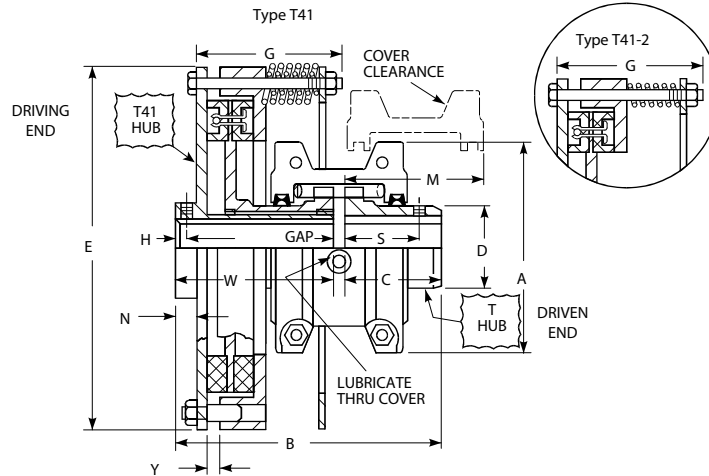

## Dimensions (mm)

Size ①	Cplg Wt w/o Bore (kg) ②		Lube Wt (kg)	A	B	C	D	E	G	H	M <sup>③</sup>	N	S	W	Y <sup>④</sup>	GAP
	T41	T41-2														
1020T	6,17	—	0,0272	97,0	130,0	47,6	39,7	177,8	63,5	5,6	47,8	10,7	39,1	79,2	5,1	3
1030T	8,16	8,16	0,0408	105,7	130,0	47,6	49,2	201,7	69,6	5,6	50,8	10,7	39,1	79,2	5,1	3
1040T	11,5	11,3	0,0544	114,3	133,1	50,8	57,2	231,6	82,3	5,6	63,5	12,2	40,1	79,2	5,1	3
1050T	16,4	16,0	0,068	135,1	150,9	60,3	66,7	270,3	82,3	5,6	63,5	10,7	44,7	87,4	5,1	3
1060T	22,0	21,3	0,0862	147,8	163,1	63,5	76,2	301,2	88,9	8,1	76,2	15,2	52,3	96,5	5,1	3
1070T	28,2	27,3	0,113	158,8	182,9	76,2	87,3	323,6	101,6	8,1	82,8	14,7	53,8	103,6	5,1	3
1080T	41,0	40,3	0,172	190,5	206,2	88,9	104,8	361,7	101,6	8,1	91,9	14,7	64,5	114,3	5,1	3
1090T	62,6	60,3	0,254	211,1	230,1	98,4	123,8	413,5	127,0	8,1	109,2	16,3	71,6	128,5	5,1	3
1100T	101	91,6	0,426	251,0	269,2	120,6	142,1	491,2	139,7	—	147,3	20,8	—	143,8	5,3	5
1110T	128	121	0,508	269,7	288,3	127,0	160,3	543,1	152,4	—	152,4	21,8	—	156,5	9,1	5
1120T	183	174	0,735	307,8	341,1	149,2	179,4	590,3	177,8	—	177,8	26,9	—	185,4	9,1	6
1130T	260	249	0,907	345,9	360,9	161,9	217,5	683,8	190,5	—	185,4	26,9	—	192,5	9,1	6
1140T	376	360	1,13	384,0	389,1	184,2	254,0	766,6	203,2	—	213,4	27,2	—	198,6	8,9	6
1150T	502	—	1,95	453,1	434,6	182,9	269,2	863,6	215,9	—	254,0	31,8	—	245,4	9,1	6
1160T	652	—	2,81	501,9	454,9	198,1	304,8	988,6	215,9	—	254,0	32,3	—	250,4	9,1	6
1170T	869	—	3,49	566,9	490,0	215,9	355,6	1065,8	241,3	—	266,7	32,3	—	267,7	9,1	6
1180T	1161	—	3,76	629,9	536,7	238,8	393,7	1160,8	241,3	—	266,7	42,7	—	291,6	9,1	6
1190T	1426	—	4,4	675,6	562,6	259,1	436,9	1263,9	254,0	—	279,4	42,7	—	297,2	9,1	6
1200T	1805	—	5,62	756,9	601,2	279,4	497,8	1377,2	254,0	—	279,4	42,7	—	315,5	9,1	6

① Refer to page 10 for General Information. Use a coupling guard that will permit air to circulate and cool the coupling.

② Weights are for couplings with Dimension C and W length hubs.

③ To remove cover without disturbing torque setting, allow M clearance.

④ With new friction segments.

⑤ Refer to Table 14 and Table 16 for maximum bores with square or rectangular keys.

Table 8 — T41 Slip Torques, Bores & Speeds

Slip Torque (Nm)		Coupling Size	Maximum Bore with Recommended Keys (mm) ⑤		Allow Speed RPM
Min	Max		T41 Hub	T Hub	
4.75	38	1020T41	24	28	3600
5.65	16	1030T41-2	32	35	3600
12.4	99	1030T41	38	43	3600
6.78	26	1040T41-2	45	50	3600
20.9	167	1040T41	50	56	3600
9.04	42	1050T41-2	60	67	3600
33.9	271	1050T41	70	80	2800
11.3	73	1060T41-2	85	95	2500
58.8	470	1060T41	100	110	2100
13.6	108	1070T41-2	110	120	1850
87.0	698	1070T41	120	140	1750
44.1	192	1080T41-2	145	170	1450
153.0	1220	1080T41	180	200	1300
74.6	316	1090T41-2	190	215	1100
254.0	2034	1090T41	225	240	950
136.0	576	1100T41-2	250	280	870
463.0	3706	1100T41	290	300	760
203	859	1110T41-2	320	335	720
689	5514	1110T41	340	360	670
294	1288	1120T41-2			
1028	8225	1120T41			
429	1830	1130T41-2			
1469	11750	1130T41			
610	2599	1140T41-2			
2079	16631	1140T41			
2938	23501	1150T41			
4067	32540	1160T41			
5536	44290	1170T41			
7570	60560	1180T41			
10168	81349	1190T41			
13558	108466	1200T41			

# Controlled Torque Clutches Types T44 & T44-2

**Figure A** — Sprocket Mounted (not included) — See Sprocket Selections **Table 10**.

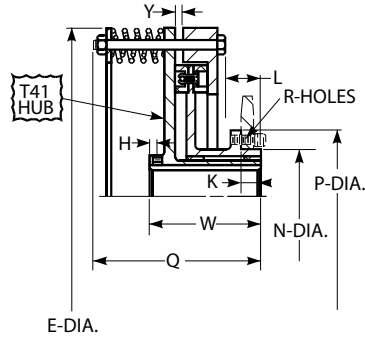

**Figure B** — Sheave Mounted (not included) — See Minimum Sheave Selections **Table 11**.

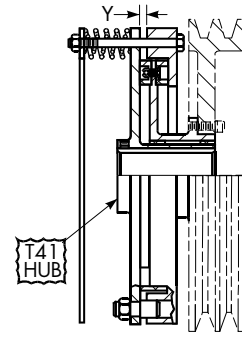

**Dimensions (mm)**

Size ①	Cplg Wt ② w/o Bore (kg)		E	H	K	L	N +0,00 -0,025	P	Q	R			W	Y ③	Max Chain Size
	T44	T44-2								Size (UNC-in)	No.	Bolt Circle Dia			
1020T	5,26	—	177,8	5,6	19,8	25,4	44,43	61,0	97,5	10-24	4	53,3	79,2	5,1	40
1030T	6,49	6,49	201,7	5,6	18,5	25,4	57,2	76,2	104,1	10-24	6	66,0	79,2	5,1	50
1040T	8,57	8,35	231,6	5,6	13,5	22,4	66,7	91,4	113,3	.250-20	6	78,7	79,2	5,1	60
1050T	13,3	12,9	270,3	5,6	19,0	30,5	76,2	106,7	121,4	.312-18	6	91,4	87,4	5,1	80
1060T	16,0	15,3	301,2	8,1	20,1	34,5	88,9	124,5	131,6	.375-16	6	106,7	96,5	5,1	100
1070T	20,5	19,6	323,6	8,1	24,6	39,1	101,6	137,2	150,4	.375-16	8	119,4	103,6	5,1	100
1080T	28,6	27,4	361,7	8,1	30,7	49,8	120,6	160,0	161,0	.438-14	8	139,7	114,3	5,1	140
1090T	44,2	42,0	443,5	8,1	34,3	56,4	139,7	185,4	194,6	.500-13	8	162,6	128,5	5,1	160
1100T	75,7	71,2	491,2	—	32,3	58,9	158,8	215,9	213,4	.625-11	8	185,4	143,8	5,3	180
1110T	105	98,4	543,1	—	37,6	64,0	171,4	238,8	231,1	.750-10	8	203,2	156,5	9,1	180
1120T	131	122	590,3	—	54,9	89,9	193,7	261,6	278,9	.750-10	10	226,1	185,4	9,1	200
1130T	205	194	683,8	—	54,9	85,9	235,0	302,3	292,6	.750-10	12	266,7	192,5	9,1	200
1140T	289	273	766,6	—	54,9	82,3	279,4	348,0	301,8	.750-10	14	312,4	198,6	8,9	200

**Table 9** — T44 Slip Torques, Bores & Speeds

Slip Torque (Nm)		Clutch Size	Maximum Bore with Recommended Keys (mm) ④	Allow Speed RPM
Min	Max			
4,75	38	1020T44	24	3600
5,65	15,8	1030T44-2	32	3600
12,4	99,4	1030T44		
6,78	26	1040T44-2	35	3600
20,9	167	1040T44		
9,04	44,8	1050T44-2	45	3600
33,9	271	1050T44		
11,3	73,4	1060T44-2	50	3600
58,8	470	1060T44		
13,6	108	1070T44-2	60	3600
87,0	698	1070T44		
44,1	192	1080T44-2	70	2800
153,0	1220	1080T44		
74,6	316	1090T44-2	85	2500
254,0	2034	1090T44		
136,0	576	1100T44-2	100	2100
463,0	3706	1100T44		
203	859	1110T44-2	110	1850
689	5514	1110T44		
294	1288	1120T44-2	120	1750
1028	8225	1120T44		
429	1830	1130T44-2	145	1450
1469	11750	1130T44		
610	2599	1140T44-2	180	1300
2079	16631	1140T44		

**Table 10** — Sprocket Selections ⑤ (Minimum Number of Teeth) — (See Figure A)

Chain Size	Clutch Size												
	1020	1030	1040	1050	1060	1070	1080	1090	1100	1110	1120	1130	1140
35	24	29	—	—	—	—	—	—	—	—	—	—	—
40	19	23	27	30	—	—	—	—	—	—	—	—	—
50	—	19	22	25	29	31	—	—	—	—	—	—	—
60	—	—	19	22	24	26	30	—	—	—	—	—	—
80	—	—	—	17	19	21	24	27	31	—	—	—	—
100	—	—	—	—	16	17	20	22	25	27	30	—	—
120	—	—	—	—	—	—	17	19	22	24	25	29	—
140	—	—	—	—	—	—	15	17	19	21	22	25	28
160	—	—	—	—	—	—	—	15	17	19	20	23	25
180	—	—	—	—	—	—	—	—	16	17	18	20	23
200	—	—	—	—	—	—	—	—	—	—	17	19	21

**Table 11** — Minimum Sheave Selections ⑥ (See Figure B)

Size	Belt Type							
	Outside Diameter (mm)			Pitch Diameter (mm)				
	3V	5V	8V	A	B	C	D	E
1020T	78,7	180,3	317,5	79,5	137,2	228,6	330,2	533,4
1030T	94,0	180,3	317,5	94,7	137,2	228,6	330,2	533,4
1040T	109,2	180,3	317,5	110,0	137,2	228,6	330,2	533,4
1050T	124,5	180,3	317,5	125,2	137,2	228,6	330,2	533,4
1060T	142,2	180,3	317,5	143,0	145,0	228,6	330,2	533,4
1070T	154,9	180,3	317,5	155,7	157,7	228,6	330,2	533,4
1080T	177,8	190,5	317,5	178,6	180,6	228,6	330,2	533,4
1090T	203,2	215,9	317,5	204,0	206,0	228,6	330,2	533,4
1100T	233,7	246,4	317,5	234,4	236,5	228,6	330,2	533,4
1110T	256,5	269,2	317,5	257,3	259,3	268,2	330,2	533,4
1120T	279,4	292,1	317,5	280,2	282,2	291,1	330,2	533,4
1130T	320,0	332,7	353,1	320,8	322,8	331,7	340,4	533,4
1140T	365,8	378,5	398,8	366,5	368,6	377,4	386,1	533,4

- ① Refer to **page 10** for General Information.
- ② Weights are for couplings with Dimension W length hubs.
- ③ With new friction segments.
- ④ Refer to **Table 16** for maximum bores with square or rectangular keys.
- ⑤ Based on minimum clearance for sprocket chain over "P" diameter.
- ⑥ Based on mounting flange restrictions.

# Piloted Controlled Torque Type T45

## Piloted Controlled Torque Assemblies

A T45 coupling is a hybrid T41/T50 assembly. It provides the shock-dampening of a Steelflex grid coupling in a piloted design for floating shafts with a controlled torque feature for overload protection.

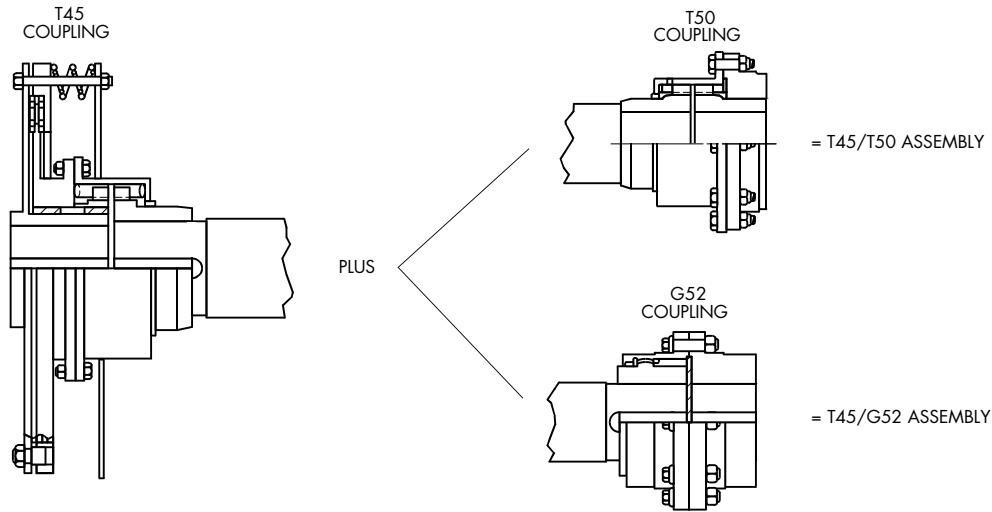

A T42 coupling is also a hybrid. It is a T41 controlled torque assembly mated to a standard flex half gear coupling. This arrangement provides for high torques and a torsionally stiffer assembly with overload protection.

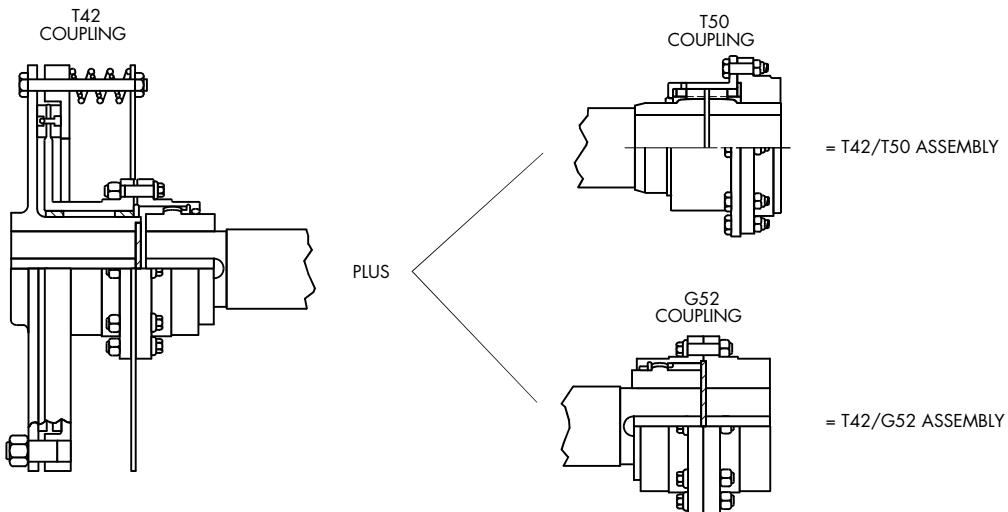

Either the T45 or T42 coupling can be used with a T50 or G52 coupling on the opposite end of the floating shaft to achieve different operational characteristics or preferences for grid or gear couplings.

**Contact Rexnord's Coupling Inquiry Department or Coupling Engineering for selection assistance.**

### T42 Flex Half Selection

T42 Control Coupling Size	G52 Flex Half Coupling Size
1030T42	1010G
1040T42	1010G
1050T42	1010G
1060T42	1015G
1070T42	1015G
1080T42	1020G
1090T42	1025G
1100T42	1030G

### T42 Flex Half Selection

T42 Control Coupling Size	G52 Flex Half Coupling Size
1110T42	1030G
1120T42	1035G
1130T42	1040G
1140T42	1050G
1150T42	1050G
1160T42	1060G
1170T42	1070G

## Optional Automatic Proximity Sensor Cutout Switch

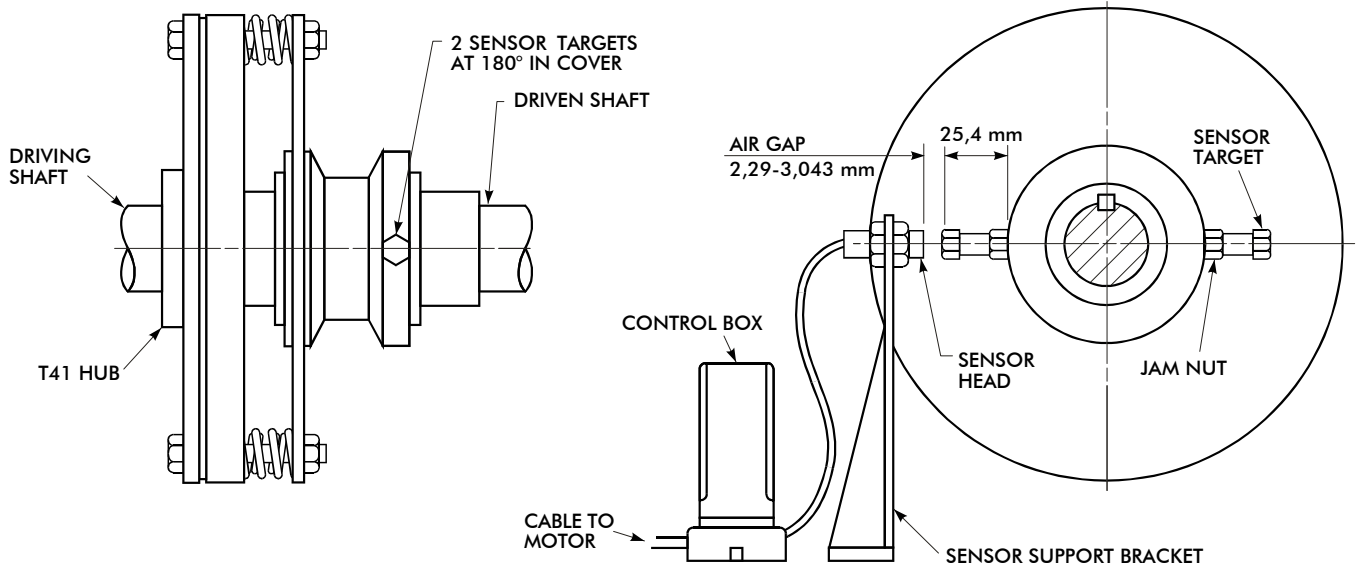

An automatic proximity cutout switch in the motor starter control circuit of controlled torque coupling or clutch application is recommended for protection of connected equipment and coupling or clutch where damaging thermal buildup could develop. Refer to Slip Torque Performance Charts on **pages 21-24** to determine if an automatic proximity sensor cutout switch is required.

The proximity cutout switch speed control is adjustable at the control box. It is set at a required cutout speed and continually compares the actual speed of the driven shaft with the set cutout speed. The control box can be mounted in an approximate space of 76,2 mm wide by 76,2 mm deep by 127 mm high.

During overload, the coupling or clutch slips at a predetermined speed. When the driven shaft speed drops below the cutout switch speed setting, it opens the motor circuit and the drag load stops the motor shaft.

When the underspeed cutout switch is wired for automatic reset, the drive is immediately ready for service (after overload is removed) without resetting the circuit at any point. To restart the drive, just press either the main or remote control start button. The motor will not maintain normal operation if the overload has not been removed because the motor contractor circuit will reopen as soon as the start button is released.

The customer may incorporate a warning light or an alarm to the circuit to signal the operator of an overload or shutdown condition.

Refer to Service Manual 428-440 for complete details.

### Overhanging Hubs

When the distance between shaft ends is greater than the coupling gap or when the coupling or clutch hub length is greater than the usable shaft length, overhang one or both hubs. For Type T41, if this results in less than one shaft diameter of hub engagement, check key stresses or use a semi-standard long T hub listed in **Table 22, page 39** or submit application details to Rexnord.

**CAUTION:** The effect of open keyways on coupling or clutch balance should always be considered.

**Dimension Y must be equal to or greater than dimension X for clearance fits, or greater than dimension X times 0,75 for interference fits.**

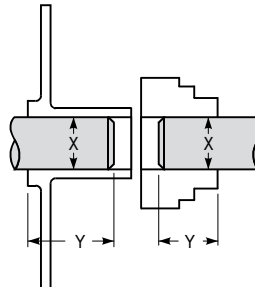

## Slip Torque Performance Charts

The following charts are for T41, T41-2, T44 and T44-2 couplings or clutches. The coupling or clutch slip torque setting and operating speed determine the length of time a coupling or clutch can slip without exceeding its thermal capacity. An automatic cutout switch (see **page 20**) is *required* on applications as indicated in the upper right of the charts (Footnote 1) and is recommended on applications where “minutes of slip and non-slip” are exceeded.

**CAUTION:** Thermal conditions in the slip torque performance charts apply only when the controlled torque hub is mounted on the driving shaft. When the controlled torque hub is mounted on the driven shaft, reduce the slip time by 50%.

During slip, heat is generated at the friction lining surfaces. The following charts specify the thermal capacities. When the torque (slip torque at the slip speed — not motor horsepower) being dissipated during a slip period exceeds the thermal capacity of the coupling or clutch, the following conditions will result:

1. Lining wear that changes the coefficient of friction and slip torque setting.
2. Excessive sleeve bearing wear.
3. Warping of controlled torque hub flange and drive plate flange.
4. Heavy smoke and possibly fire.
5. Complete coupling or clutch failure.

The limits specified in these charts must be adhered to for proper operation of controlled torque couplings or clutches in overload systems. Refer to Factory all applications requiring operation beyond the coupling or clutch thermal capacity.

SIZE 1020T41 & 1020T44

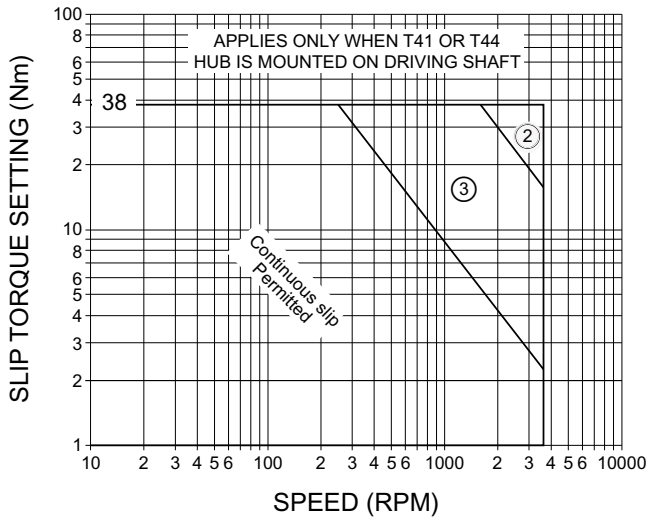

- ② - 17 seconds slip permitted if followed by 6 minutes non-slip
- ③ - 34 seconds slip permitted if followed by 6 minutes non-slip

SIZE 1030T41 & 1030T44

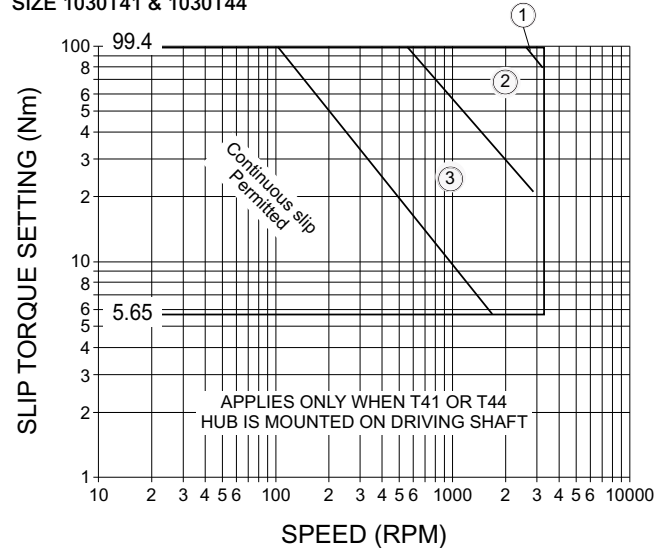

- ① - Automatic cutout switch required
- ② - 20 seconds slip permitted if followed by 7 minutes non-slip
- ③ - 40 seconds slip permitted if followed by 7 minutes non-slip

SIZE 1040T41 & 1040T44

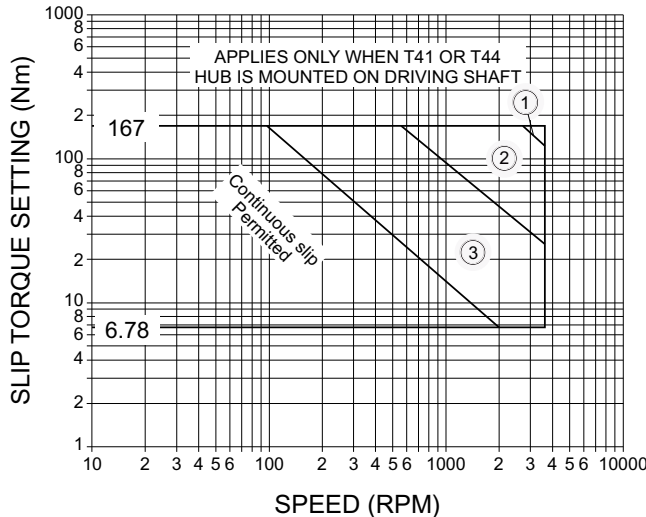

- ① - Automatic cutout switch required
- ② - 23 seconds slip permitted if followed by 7.5 minutes non-slip
- ③ - 45 seconds slip permitted if followed by 7.5 minutes non-slip

SIZE 1050T41 & 1050T44

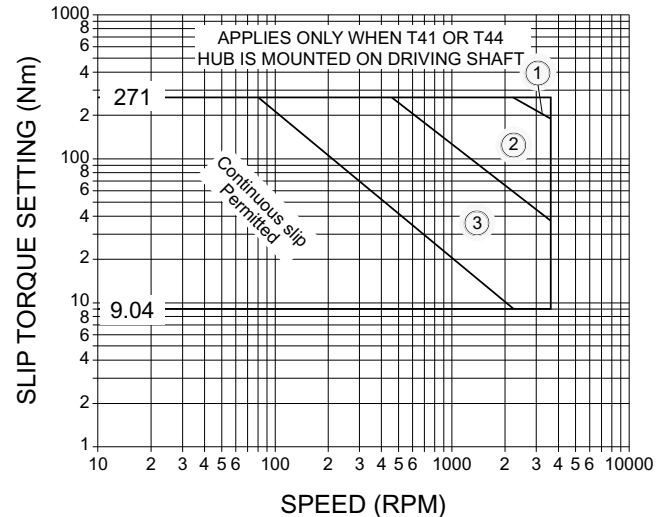

- ① - Automatic cutout switch required
- ② - 27 seconds slip permitted if followed by 9 minutes non-slip
- ③ - 54 seconds slip permitted if followed by 9 minutes non-slip

# Slip Torque Performance Charts

SIZE 1060T41 & 1060T44

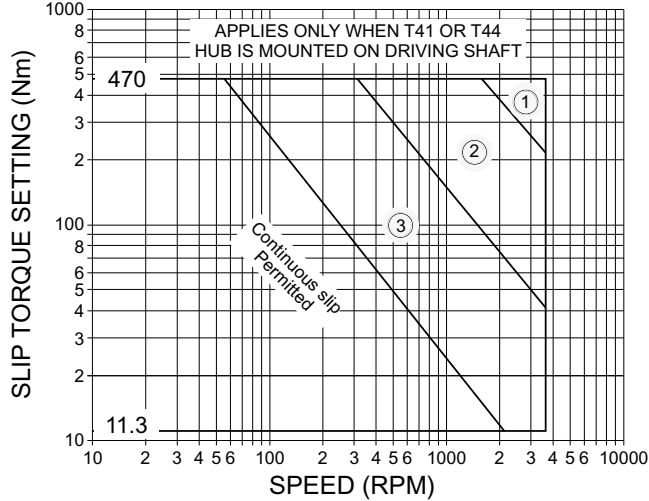

- ① - Automatic cutout switch required
- ② - 30 seconds slip permitted if followed by 10 minutes non-slip
- ③ - 60 seconds slip permitted if followed by 10 minutes non-slip

SIZE 1070T41 & 1070T44

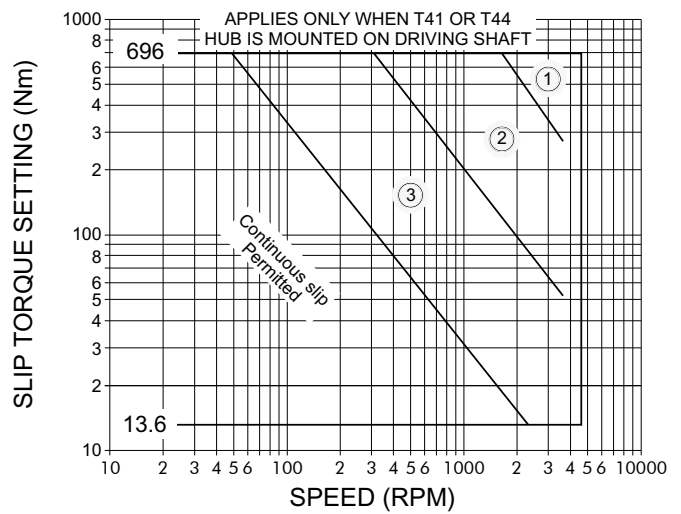

- ① - Automatic cutout switch required
- ② - 33 seconds slip permitted if followed by 11 minutes non-slip
- ③ - 66 seconds slip permitted if followed by 11 minutes non-slip

SIZE 1080T41 & 1080T44

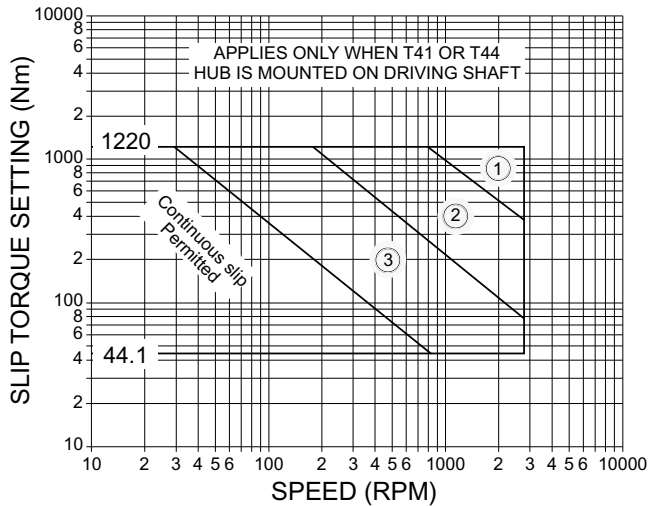

- ① - Automatic cutout switch required
- ② - 36 seconds slip permitted if followed by 12 minutes non-slip
- ③ - 72 seconds slip permitted if followed by 12 minutes non-slip

SIZE 1090T41 & 1090T44

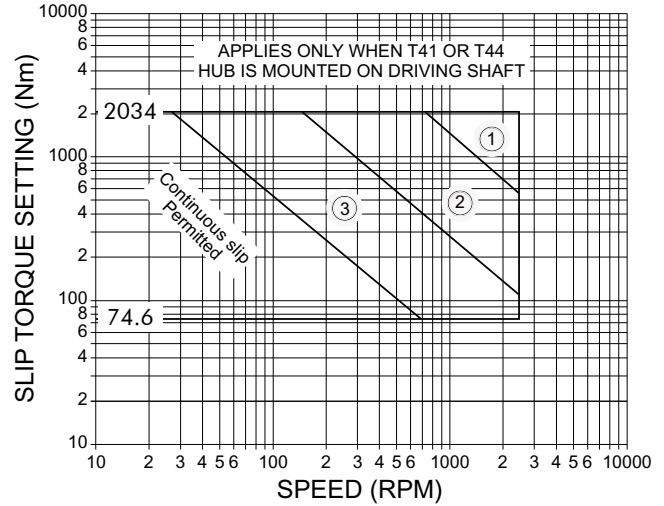

- ① - Automatic cutout switch required
- ② - 40 seconds slip permitted if followed by 14 minutes non-slip
- ③ - 80 seconds slip permitted if followed by 14 minutes non-slip

SIZE 1100T41 & 1100T44

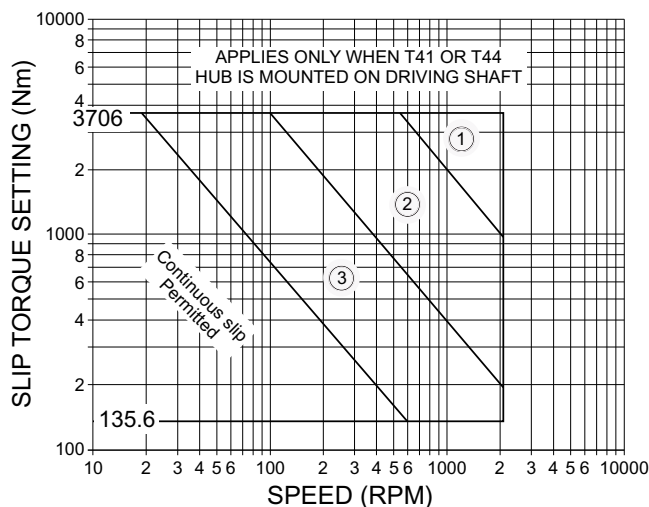

- ① - Automatic cutout switch required
- ② - 48 seconds slip permitted if followed by 16 minutes non-slip
- ③ - 96 seconds slip permitted if followed by 16 minutes non-slip

SIZE 1110T41 & 1110T44

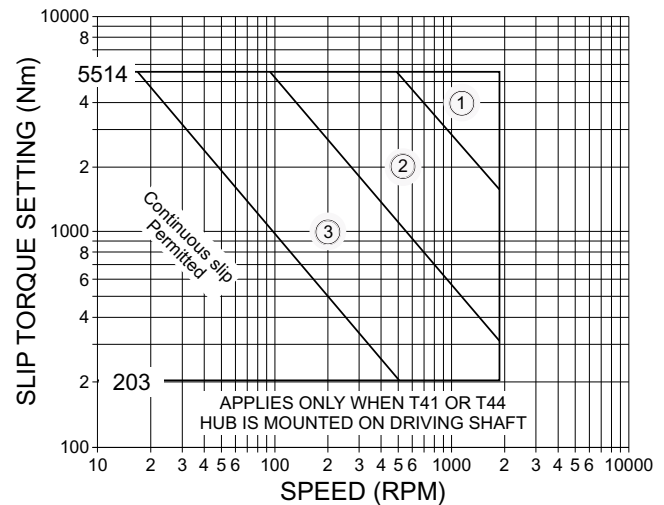

- ① - Automatic cutout switch required
- ② - 55 seconds slip permitted if followed by 18 minutes non-slip
- ③ - 110 seconds slip permitted if followed by 18 minutes non-slip

# Slip Torque Performance Charts

SIZE 1120T41 & 1120T44

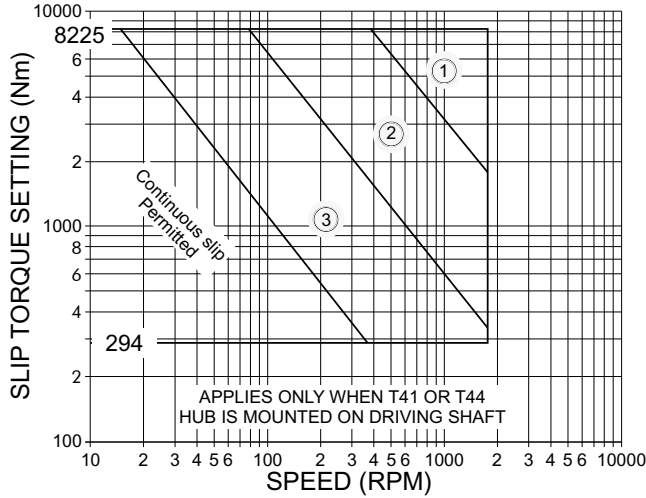

- ① - Automatic cutout switch required
- ② - 60 seconds slip permitted if followed by 20 minutes non-slip
- ③ - 120 seconds slip permitted if followed by 20 minutes non-slip

SIZE 1130T41 & 1130T44

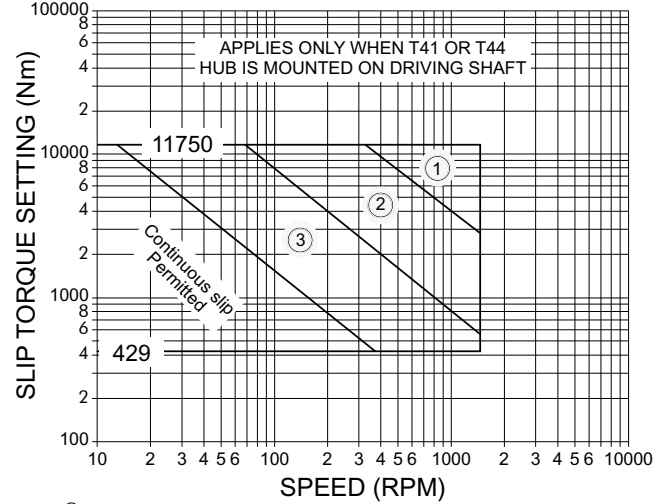

- ① - Automatic cutout switch required
- ② - 70 seconds slip permitted if followed by 23 minutes non-slip
- ③ - 140 seconds slip permitted if followed by 23 minutes non-slip

SIZE 1140T41 & 1140T44

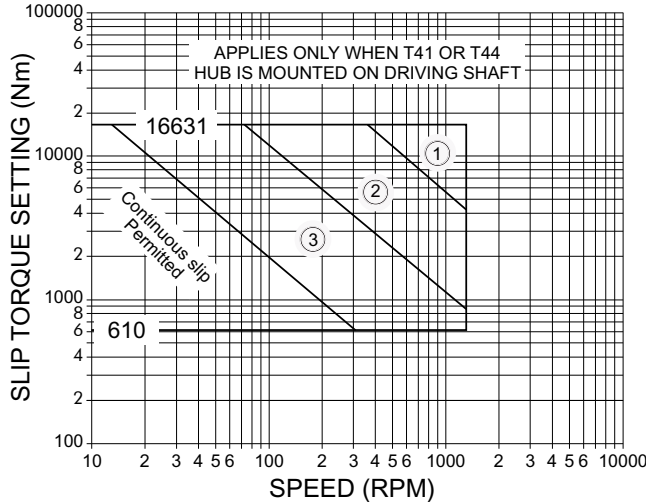

- ① - Automatic cutout switch required
- ② - 80 seconds slip permitted if followed by 26 minutes non-slip
- ③ - 160 seconds slip permitted if followed by 26 minutes non-slip

SIZE 1150T41

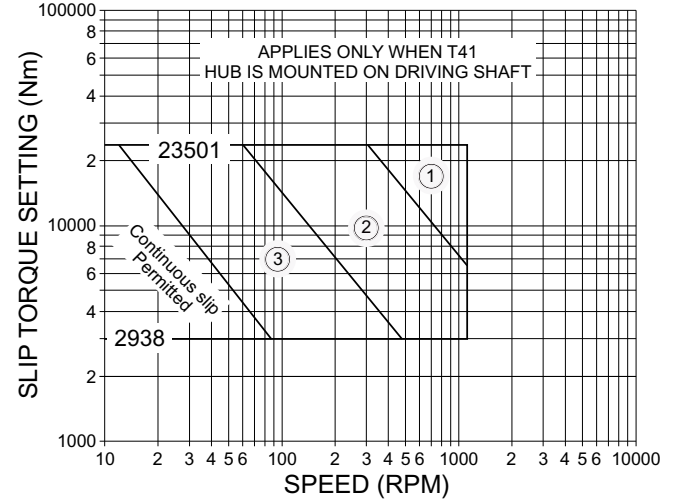

- ① - Automatic cutout switch required
- ② - 92 seconds slip permitted if followed by 31 minutes non-slip
- ③ - 184 seconds slip permitted if followed by 31 minutes non-slip

SIZE 1160T41

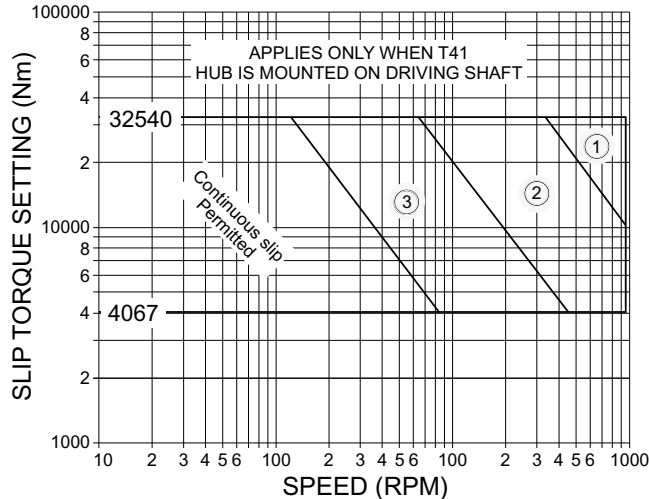

- ① - Automatic cutout switch required
- ② - 106 seconds slip permitted if followed by 35 minutes non-slip
- ③ - 212 seconds slip permitted if followed by 35 minutes non-slip

SIZE 1170T41

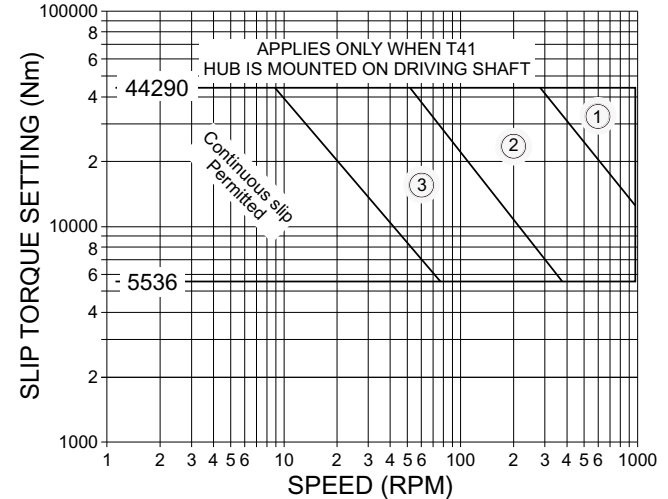

- ① - Automatic cutout switch required
- ② - 110 seconds slip permitted if followed by 37 minutes non-slip
- ③ - 220 seconds slip permitted if followed by 37 minutes non-slip

# Slip Torque Performance Charts

SIZE 1180T41

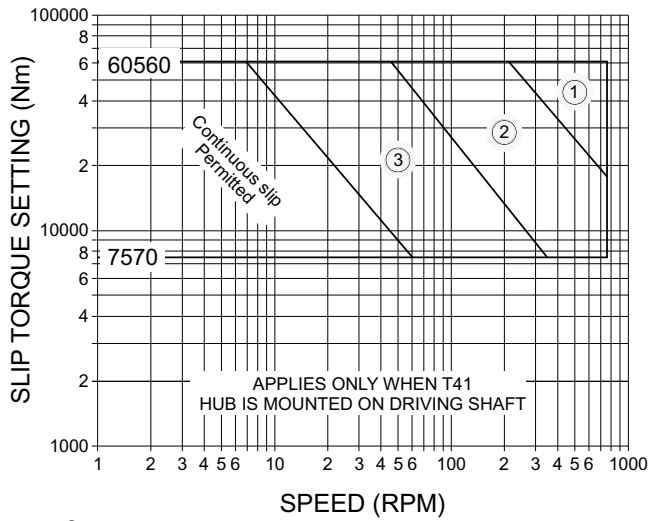

- ① - Automatic cutout switch required
- ② - 122 seconds slip permitted if followed by 40 minutes non-slip
- ③ - 224 seconds slip permitted if followed by 40 minutes non-slip

SIZE 1190T41

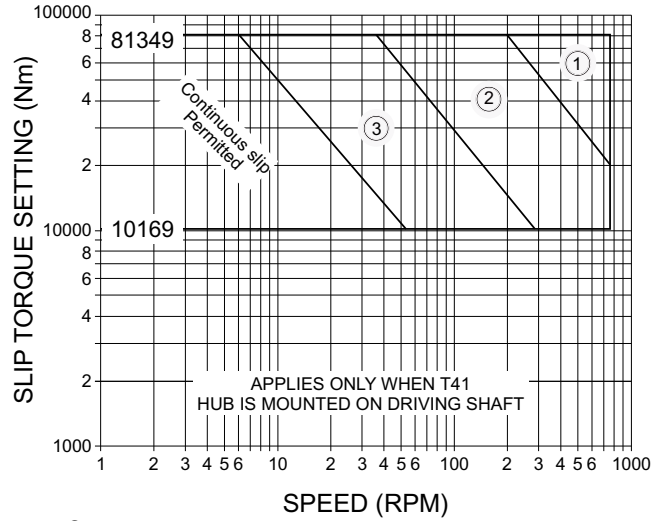

- ① - Automatic cutout switch required
- ② - 133 seconds slip permitted if followed by 44 minutes non-slip
- ③ - 266 seconds slip permitted if followed by 44 minutes non-slip

SIZE 1200T41

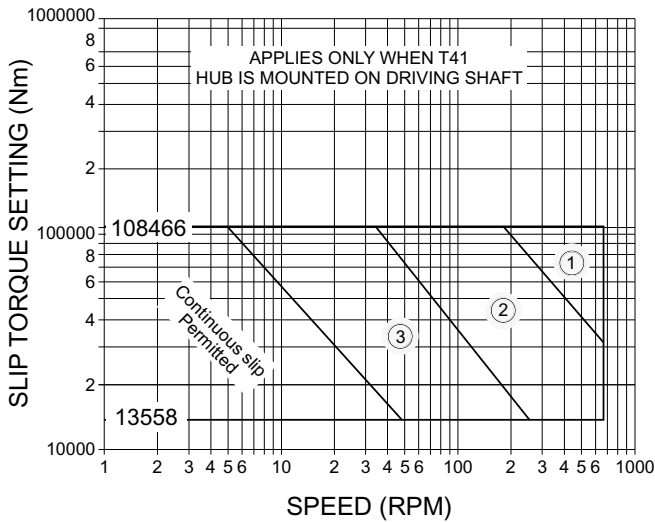

- ① - Automatic cutout switch required
- ② - 150 seconds slip permitted if followed by 50 minutes non-slip
- ③ - 300 seconds slip permitted if followed by 50 minutes non-slip



# Floating Shaft Type T50

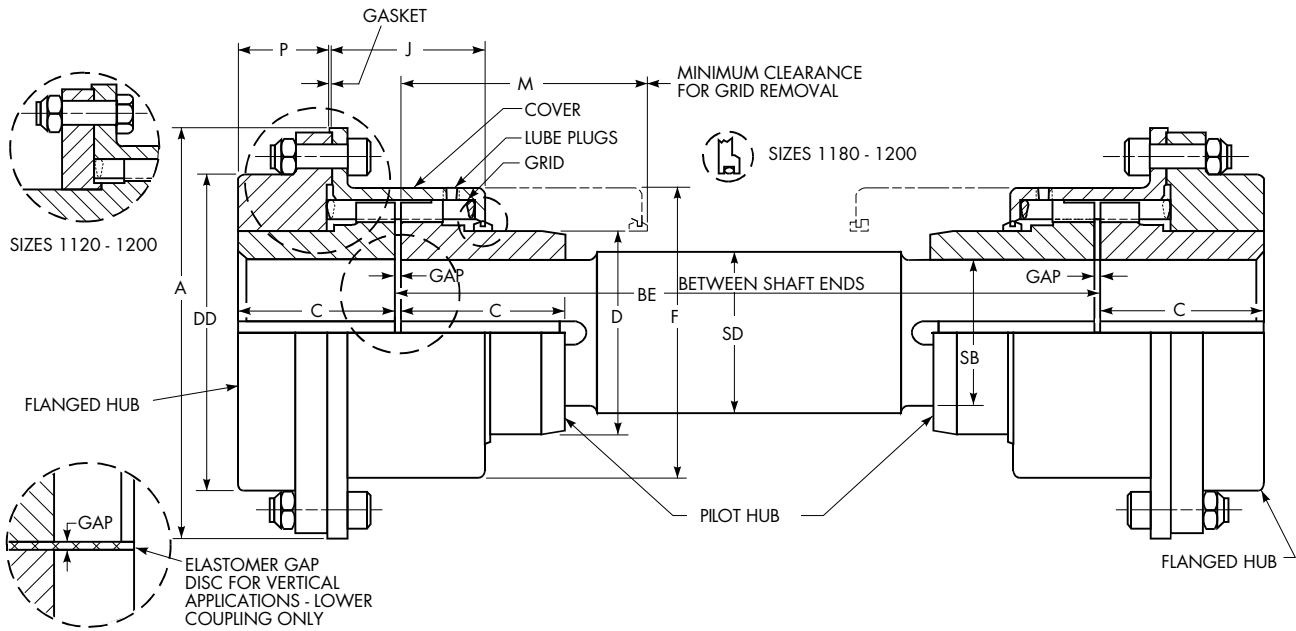

## Dimensions (mm)

Size ①	Torque Rating (Nm) ②	Max Bore (Flanged Hub) (mm) ③	Min Bore ④	Pilot Hub Max Bore (mm)	Wt Per Cplg No Bore (kg)	Wt Added per mm of Length of SD Dia Between Hubs	Lube Wt per Cplg (kg)	A	BE Min	C	D	DD	F	J	M	P	SB	SD	GAP
1030T	149	35	13	27,0	3,9	0,00498	0,0408	115,9	162	47,6	49,2	83,7	80,8	50,3	77,7	26,8	27,0	28,6	3
1050T	435	50	13	36,5	8,84	0,00893	0,068	157,5	195	60,3	66,7	105,2	104,8	59,2	94,0	36,2	36,5	38,1	3
1070T	994	67	20	49,2	15,6	0,016	0,113	182,9	213	76,2	87,3	126,5	129,0	65,9	103,1	49,8	49,2	50,8	3
1080T	2 050	80	27	61,9	26,4	0,025	0,172	218,4	275	88,9	104,8	154,9	156,2	85,9	134,1	52,13	61,9	63,5	3
1090T	3 730	95	27	74,6	37,2	0,036	0,254	244,9	294	98,4	123,8	180,3	175,8	92,2	143,8	58,5	74,6	76,2	3
1100T	6 280	110	42	92,1	62,8	0,056	0,426	286,0	372	120,6	142,1	211,3	208,3	117,3	181,4	69,3	92,1	95,2	5
1110T	9 320	120	42	101,6	83,6	0,067	0,508	324,1	391	127,0	160,3	245,4	228,6	122,2	190,5	73,9	101,6	104,8	5
1120T	13 700	140	61	117,5	97,9	0,09	0,735	327,2	453	149,2	179,4	179,3	257,0	146,3	220,0	83,6	117,5	120,6	6
1130T	19 900	170	67	133,4	140	0,115	0,907	365,3	463	161,9	217,5	217,4	295,1	149,5	225,0	94,8	133,4	136,5	6
1140T	28 600	200	67	142,9	210	0,131	1,13	419,1	482	184,2	254,0	254,0	335,8	155,8	234,7	113,8	142,9	146,0	6
1150T	39 800	215	108	161,9	277	0,168	1,95	477,5	549	182,9	269,2	269,2	391,2	177,4	268,2	101,7	161,9	165,1	6
1160T	55 900	240	121	200,0	381	0,254	2,81	548,6	587	198,1	304,8	304,8	442,0	189,4	287,0	111,9	200,0	203,2	6
1170T	74 600	280	134	200,0	519	0,254	3,49	604,5	622	215,9	355,6	355,6	494,3	201,0	304,8	124,6	200,0	203,2	6
1180T	103 000	300	153	225,4	718	0,322	3,76	665,5	673	238,8	393,7	393,7	556,3	226,9	330,2	141,4	225,4	228,6	6
1190T	137 000	335	153	250,8	898	0,397	4,4	708,7	711	259,1	436,9	436,9	599,4	241,7	349,5	157,6	250,8	254,0	6
1200T	186 000	360	178	276,2	1205	0,48	5,62	782,3	744	279,4	497,8	497,8	622,9	251,8	365,8	172,8	276,2	279,4	6

① Refer to **page 10** for General Information.

② Peak torque capacity is two times the published rating.

③ Maximum bores are reduced for hubs furnished with an interference fit and a setscrew over the keyway. Refer to Rexnord Engineering Sheet 427-105 for details.

④ Minimum bore is the smallest bore to which a Rough Stock Bore (RSB) hub can be bored. Depending upon coupling size, RSB hubs may have only a blind centering hole or a through hole that will permit remachining of the hubs to the minimum bores specified.

# Floating Shaft Type T50

## Floating Shaft/Selections

**Introduction** — Floating shaft diameters have been preselected to transmit the coupling torque and need only to be checked for allowable speed.

**Construction** — Standard shafts are solid, AISI 1018 or 1020 cold rolled steel. Also available is an optional solid, AISI 1018, fully turned, hot-rolled steel shaft.

### Determine the Allowable Shaft Length

- Select the coupling size per **page 6** and **25**.
- From **page 25**, determine shaft diameter (Dimension SD) for the coupling selected.
- From the **Table 12**, locate the floating shaft diameter (Dimension SD) determined in Step B.

D. Determine the allowable shaft length for the required operating speed.

For speeds under 540 rpm — Read the maximum allowable shaft length to the left of the required shaft diameter.

For speeds over 540 rpm — Trace right from the shaft diameter determined along the diagonal line to the point of intersection with the required vertical operating speed line. Trace right along the horizontal line to the right and read the maximum allowable shaft length.

E. Determine if shaft requires balancing. Locate point where operating speed and floating shaft length cross. Balance is required when point is located to the right of bold line.

F. If a longer shaft is required, reduce the operating speed if practical, or select the next larger size coupling.

**NOTE:** For such conditions, the use of a tubular shaft design should be considered. Refer application details to the local Rexnord representative.

**Table 12 — Floating Shaft Selections**

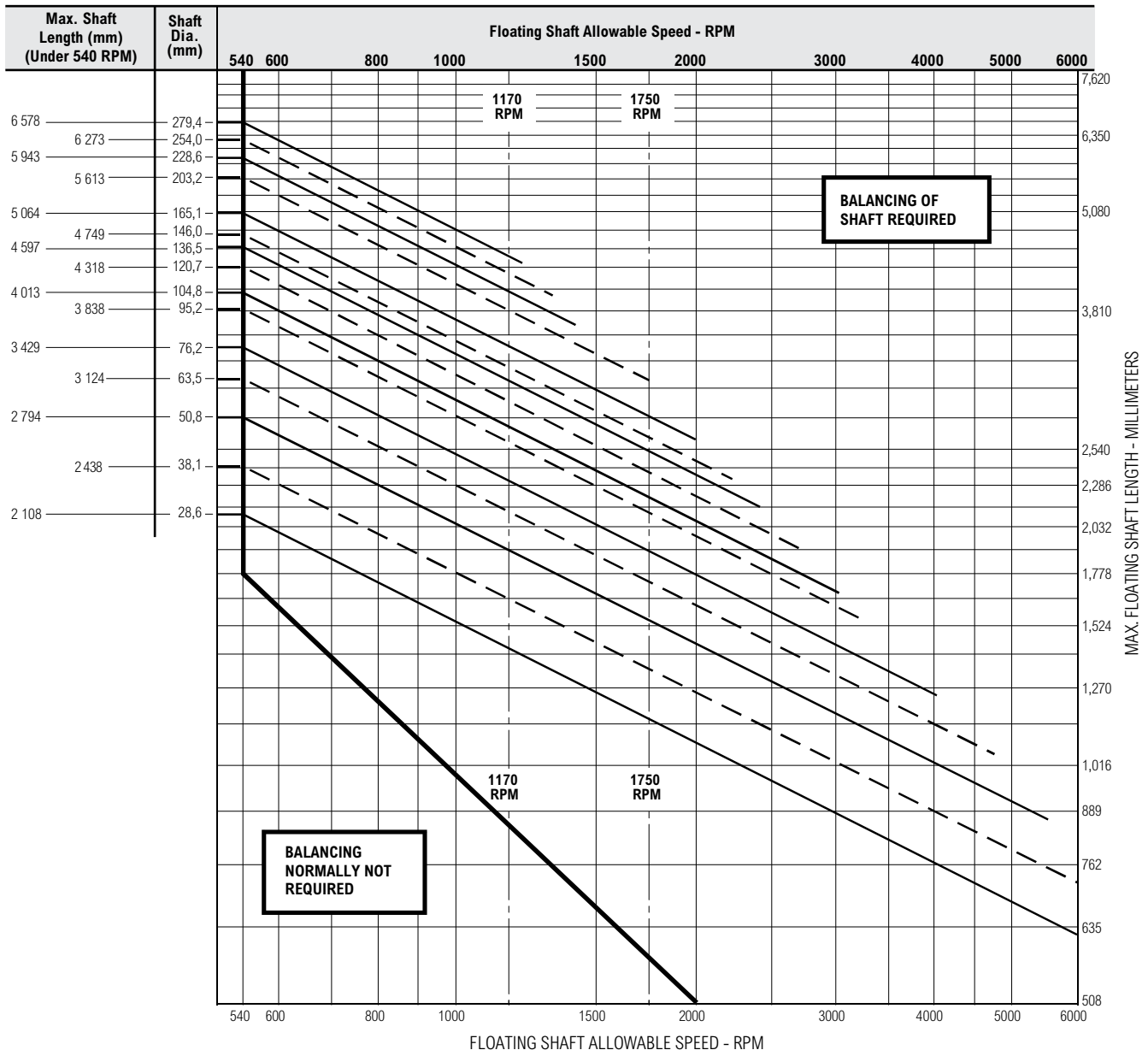

## Caliper Disc Brake System

Rexnord will supply Type T63 Brake Disc Couplings for use with calipers and power systems by others, or a fail-safe Falk Caliper Disc Brake System. The system is comprised of a Falk Steelflex Coupling, caliper disc brake, basic hydraulic circuits and components. These systems are designed to be used as parking or holding brakes or limited usage dynamic stopping brakes.

Rexnord will purchase for resale the caliper disc brakes and hydraulic components preassembled in a power package.

Rexnord can assemble or mount the T63 coupling, disc brake and hydraulic system when these components are ordered in conjunction with Falk gear drives.

### Capabilities

The Falk Steelflex Disc Brake Coupling with Caliper Brake System has an assigned coupling brake rating range of 11 to 16 938 Nm.

### Description of the Disc Brake Coupling and Caliper System

The system consists of a standard T63 coupling using a disc diameter and thickness compatible with one caliper brake manufacturer. Both MICO-Minnesota Automotive Inc. and Goodyear Aerospace Corporation caliper disc brakes are used on Sizes 50T63 through 120T63 and 130T63, respectively. Both caliper manufacturers use different mounting hole patterns and bracket styles. MICO and Goodyear caliper disc brakes require hydraulic pressure.

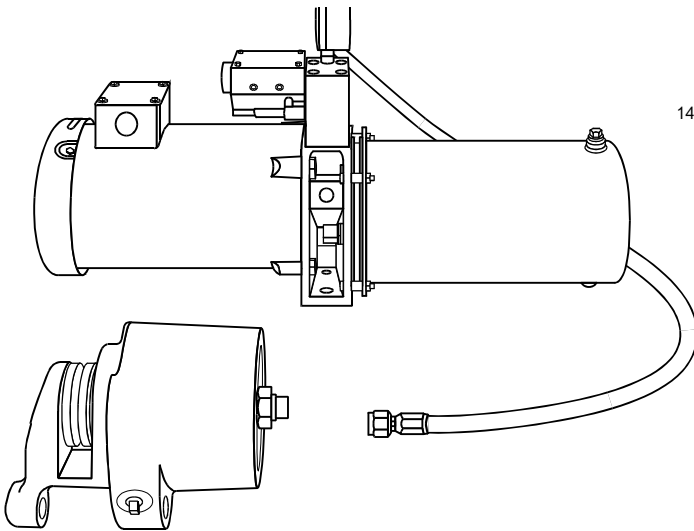

### Caliper Disc Brakes

The caliper disc brake is spring-loaded to apply the brake. Hydraulic pressure is required to release or "hold off" the brake. Normal operation is to have the brake pressurized in the released position with the hydraulic system running. Conditions such as an electric power or pressure system failure, which reduces the system pressure below the release pressure of the brake, will initiate a brake application.

### Hydraulic Brake System

The system consists of an oil tank, filter, gear pump and electric motor, relief valve, check valve, solenoid direction control valve, pressure gauge, duplex pressure switch, 1,52 meter hydraulic hose with connections and caliper disc brake.

### Operation

The hydraulic brake system is actuated by turning on its electric motor. The motor drives a gear pump which produces a flow of oil between pump and solenoid directional control valve. When the solenoid directional control valve is energized, oil pressure rises in the caliper brake, compressing the Belleville springs to release the brake.

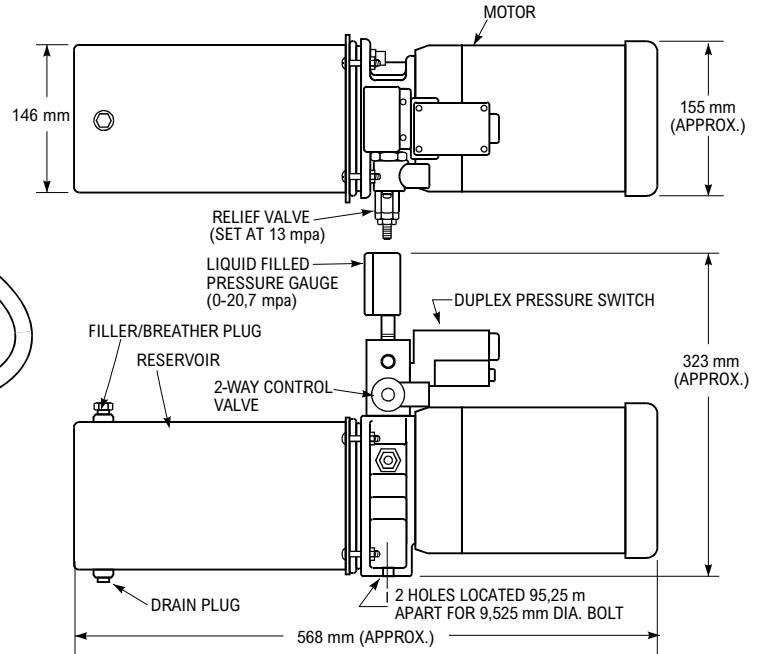

## Disc Brake Type T63

**NOTE:** Falk Type T63 couplings or brake assemblies are not approved as a primary brake for applications used to lift or transport people such as elevators, escalators, hoists, lifts, etc.

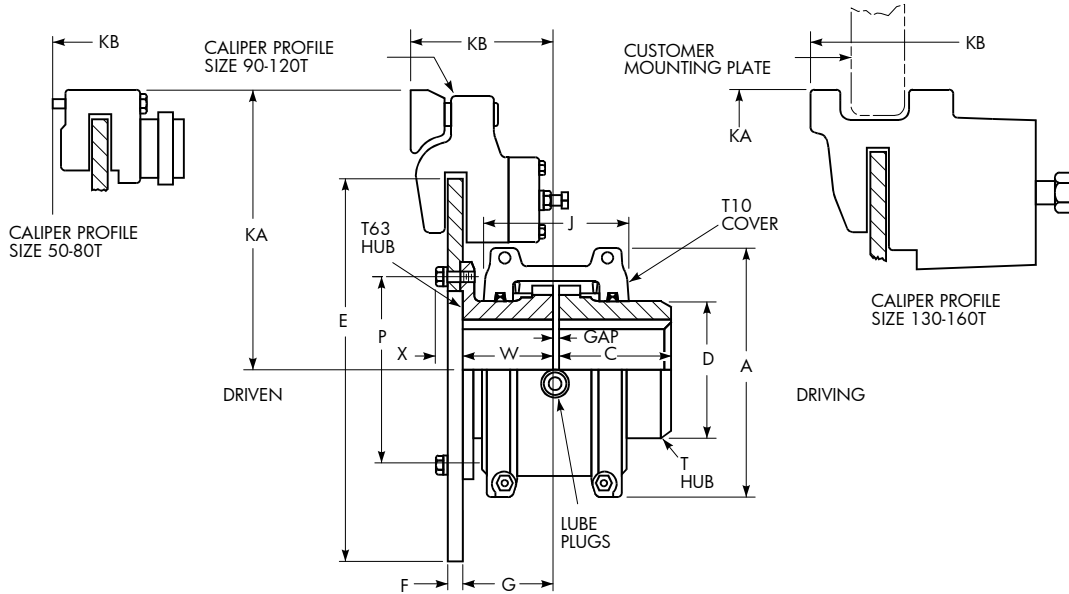

### Dimensions (mm)

Size ①	Cplg Brake Rating (Nm)	Brake Disc Dia x Thickness (E x F) ③	Allow Speed RPM ④	Max Bore (mm) ②	Min Bore (mm) ⑤	Cplg Wt with No Bore & No Disc (kg)	Lube Wt (kg)	A	C	D	G	J	P	W	X	GAP
20T	11	203 x 6,4	4500	28	13	2,55	0,0272	97,0	47,6	39,7	59,9	66,7	71,4	60,5	11,7	3
30T	35	254 x 6,4	4500	35	13	3,31	0,0408	105,7	47,6	49,2	59,9	68,3	79,4	60,5	11,7	3
40T	65	254 x 6,4	4500	43	13	4,26	0,0544	114,3	50,8	57,2	59,9	69,9	98,4	60,5	11,7	3
50T	118	254 x 6,4	4150	50	13	6,35	0,068	135,1	60,3	66,7	59,9	80,9	108,0	60,5	13,2	3
60T	209	305 x 6,4	3800	56	20	9,57	0,0862	147,8	63,5	76,2	88,6	93,5	125,4	88,1	15,2	3
70T	331	305 x 6,4	3250	67	20	12,3	0,113	158,8	76,2	87,3	88,6	96,8	133,4	88,1	15,2	3
80T	637	305 x 6,4	2850	80	27	19,8	0,172	190,5	88,9	104,8	88,6	115,6	152,4	88,1	18,00	3
90T	1084	407 x 12,7	2700	95	27	28,4	0,254	211,1	98,4	123,8	87,9	122,2	179,4	88,1	26,9	3
100T	1897	407 x 12,7	2400	110	42	47,7	0,426	251,0	120,6	142,1	119,1	155,4	215,9	119,1	29,5	5
110T	2846	458 x 12,7	2250	120	42	64,9	0,508	269,7	127,0	160,3	146,00	161,5	241,3	146,00	29,5	5
120T	4336	509 x 12,7	2025	140	61	92,1	0,735	307,8	149,2	179,4	150,1	191,5	276,2	149,4	33,00	6
130T	6098	559 x 12,7	1800	170	67	132	0,907	345,9	161,9	217,5	153,4	195,1	295,3	152,4	35,6	6
140T	8808	610 x 12,7	1650	200	67	185	1,13	384,0	184,2	254,0	159,8	201,2	330,2	158,8	38,1	6
150T	12 195	763 x 12,7	1500	215	108	253	1,95	453,1	182,9	269,2	179,8	271,5	368,3	182,9	31,5	6
160T	16 938	915 x 12,7	1350	240	121	336	2,81	501,9	198,1	304,8	195,1	278,4	400,0	198,1	31,5	6

① Refer to **page 10** for General Information.

② Couplings will be furnished for interference fit without a setscrew. Clearance fit and/or hubs with setscrews are not recommended. Rexnord standards apply unless otherwise specified. Maximum bores listed are based on recommended keys shown in **Table 26, page 40**. For other maximum bore-key combinations that can be manufactured to order, refer to **Table 14, page 34**.

③ Refer to Rexnord for discs with dimensions other than shown.

④ Consult Factory for higher speeds.

⑤ Minimum bore is the smallest bore to which a Rough Stock Bore (RSB) hub can be bored. Depending upon coupling size, RSB hubs may have only a blind centering hole or a through hole that will permit remachining of the hubs to the minimum bores specified.

# Disc Brake Type T63

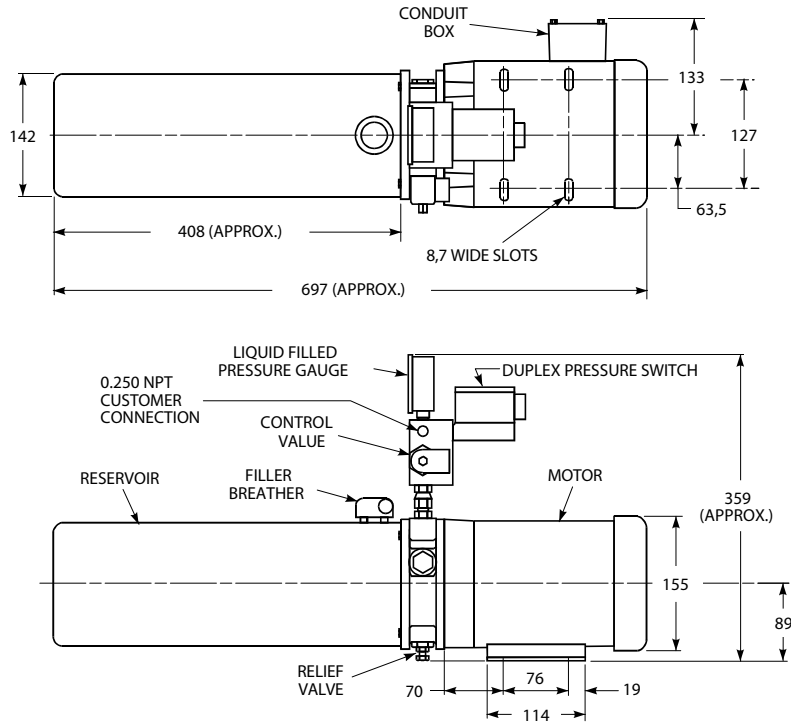

## Caliper System Dimensions (mm)

Coupling Size	Caliper Brake ②				KA	KB ③
	Brand	Model No. ①	Torque (Nm)			
			Min	Max		
20T	<b>These sizes are best activated by Electromagnetic or Pneumatic Caliper Systems</b>					
30T						
40T						
50T	MICO, Inc.	02-515-002	62	122	158,0	96,5
60T		02-515-004	157	244	183,4	125,2
70T		02-515-008	475	556	183,4	125,2
80T		02-515-006	632	773	183,4	125,2
90T		02-530-306	701	1 456	292,1	138,7
100T		02-530-628	724	2 481	292,1	169,9
110T		02-530-628	830	2 847	342,9	196,8
120T		02-530-600	1 883	4 461	336,6	200,9
130T	Meritor	PD1591 15 1	2 203	8 262	336,6	216,9
140T		PD1591 15 1	2 430	9 110	362,0	223,3
150T		SCL25 15 4	4 661	23 304	461,8	245,9
160T		SCL25 15 4	5 678	28 388	539,0	260,3

① These brakes use hydraulic oil (NOT brake fluid). Any high grade hydraulic oil with viscosities of 150 SSU-350 SSU @ 38°C is suitable.

② Maximum torque shown is rating with new pads. Minimum torque shown is rating at point when caliper requires adjustment for pad wear.

③ Dimension KB is to caliper mounting surface for Coupling Sizes 50T thru 120T, and to caliper edge for Coupling Sizes 130T and larger.

# High-Speed Type T70

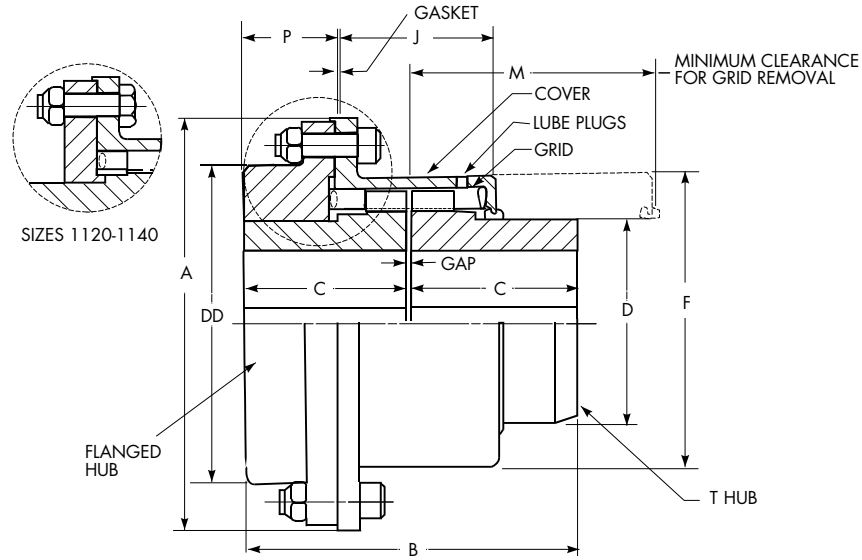

## Dimensions (mm)

Size ①	Torque Rating (Nm) ③	Allow Speed RPM ④	Max Bore (mm) ⑤	Min Bore (mm) ⑥	Cplg Wt with No Bore (kg)	Lube Wt (kg)	A	B	C	D	DD	F	J	M	P	GAP
1030T	149	10 000	35	13	3,9	0,041	115,9	98,6	47,6	49,2	83,7	80,8	50,3	77,7	26,8	3
1050T	435	9 000	50	13	8,8	0,068	157,5	124,0	60,3	66,7	105,2	104,8	59,2	94,0	36,2	3
1070T	994	8 200	67	20	15,6	0,113	182,9	155,4	76,2	87,3	126,5	129,0	65,9	103,1	49,8	3
1080T	2 050	7 100	80	27	26,4	0,172	218,4	180,8	88,9	104,8	154,9	156,2	85,9	134,1	52,13	3
1090T	3 730	6 000	95	27	37,2	0,254	244,9	200,2	98,4	123,8	180,3	175,8	92,2	143,8	58,5	3
1100T	6 280	4 900	110	42	62,8	0,426	286,0	246,1	120,6	142,1	211,3	208,3	117,3	181,4	69,3	5
1110T	9 320	4 500	120	42	83,6	0,508	324,1	258,8	127,0	160,3	245,4	228,6	122,2	190,5	73,9	5
1120T	13 700	4 000	140	61	97,9	0,735	327,2	304,8	149,2	179,4	179,3	257,0	146,3	220,0	83,6	6
1130T	19 900	3 600	170	67	140	0,907	365,3	330,2	161,9	217,5	217,4	295,1	149,5	225,0	94,8	6
1140T	28 600	3 300	200	67	210	1,13	419,1	374,6	184,2	254,0	254,0	335,8	155,8	234,7	113,8	6

① Refer to **page 10** for General Information.

② Maximum bore is for hub with keyway for rectangular key.

③ Peak torque capacity is two times the published rating. Torque ratings for hubs with bushings differ from those shown, refer to **Table 18, page 36**.

④ Consult Factory for higher speeds.

⑤ Maximum bores are reduced for hubs furnished with an interference fit and a setscrew over the keyway. Refer to Rexnord Engineering Sheet 427-105 for details.

⑥ Minimum bore is the smallest bore to which a Rough Stock Bore (RSB) hub can be bored. Depending upon coupling size, RSB hubs may have only a blind centering hole or a through hole that will permit remachining of the hubs to the minimum bores specified.

# Engine Flywheel Adapter Type T90

Used primarily to connect the flywheel of an engine to the driven machinery. Adapter plates are designed to accommodate standard SAE J620 bolt patterns. The T90 design provides for higher torque ratings with resulting smaller sizes and lower costs than elastomeric coupling designs. The flexible gridmember provides torsional damping in addition to accepting misalignment. Adapter plates are bolted and doweled to the hub to provide a secure joint.

**Selection** — Determine the proper Steelflex coupling size using the selection method. Check size selected against those shown in table below for the clutch size used on the engine flywheel. If the coupling size is not shown, refer all details to Rexnord.

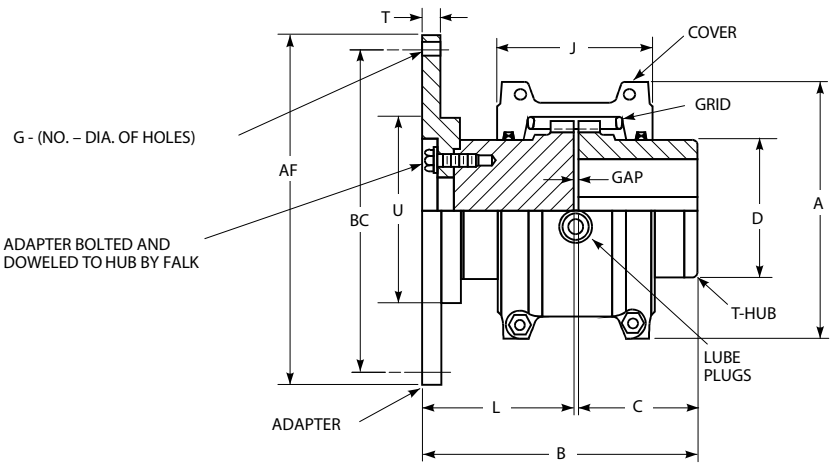

## Dimensions

Clutch Diameter	Adapter (values in inches)				Cplg Size ①	Assembly Torque Rating (Nm) ④	Allow Speed RPM ⑤	Max Bore Sq Key (mm) ⑥	Min Bore (mm) ⑦	Cplg Wt No Bore In T-Hub (kg)	WR <sup>2</sup> (kg <sup>2</sup> )	A	B	C	D	J	L	U	GAP
	AF + .000 - .005	BC	G	T															
6.5	8.500	7.875	6 - 0.344	0.375	1050T	395	3 600	50	13	8,16	0,025	138,2	141,7	60,5	66,5	79,2	78,0	127,0	3
				0.375	1060T	621	3 600	56	20	10,4	0,031	150,9	150,9	63,5	76,2	91,9	84,1	139,7	3
				0.375	1070T	904	3 600	67	20	13,2	0,038	162,1	176,3	76,2	87,4	95,2	96,8	149,4	3
7.5	9.500	8.750	8 - 0.344	0.375	1050T	395	3 600	50	13	9,07	0,034	138,2	141,7	60,5	66,5	79,2	78,0	127,0	3
				0.375	1060T	621	3 600	56	20	10,9	0,040	150,9	150,9	63,5	76,2	91,9	84,1	139,7	3
				0.375	1070T	904	3 600	67	20	13,6	0,047	162,1	176,3	76,2	87,4	95,2	96,8	149,4	3
8	10.375	9.625	6 - 0.406	0.375	1050T	395	3 600	50	13	9,53	0,044	138,2	141,7	60,5	66,5	79,2	78,0	127,0	3
				0.375	1060T	621	3 600	56	20	11,8	0,050	150,9	150,9	63,5	76,2	91,9	84,1	139,7	3
				0.375	1070T	904	3 600	67	20	14,5	0,057	162,1	176,3	76,2	87,4	95,2	96,8	149,4	3
				0.500	1080T	1 860	3 600	80	27	21,8	0,097	193,5	205,0	88,9	104,6	115,8	112,8	165,1	3
10	12.375	11.625	8 - 0.406	0.500	1080T	1 860	3 600	80	27	24,0	0,145	193,5	205,0	88,9	104,6	115,8	112,8	165,1	3
11.5	13.875	13.125	8 - 0.406	0.500	1090T	3 390	3 600	95	27	33,6	0,240	212,9	227,3	98,6	124,0	122,2	125,5	190,5	3
14	18.375	17.250	8 - 0.531	0.650	1100T	5 710	2 440	110	42	60,3	0,791	251,0	276,9	120,6	142,0	155,4	151,4	212,9	5
				0.750	1110T	8 470	2 250	120	42	73,5	0,965	269,7	292,1	127,0	160,3	161,5	160,3	231,9	5
16	20.375	19.250	8 - 0.531	0.650	1100T	5 710	2 440	110	42	65,8	1,097	251,0	276,9	120,6	142,0	155,4	151,4	212,9	5
				0.750	1110T	8 470	2 250	120	42	79,4	1,319	269,7	292,1	127,0	160,3	161,5	160,3	231,9	5
18	22.500	21.375	6 - 0.656	0.750	1110T	5 710	2 250	120	42	86,2	1,827	269,7	292,1	127,0	160,3	161,5	160,3	231,9	5
				0.750	1120T	12 400	2 025	140	61	110	2,096	307,8	341,1	149,4	179,3	191,5	185,4	254,0	6
				0.900	1130T	10 100	1 800	170	67	150	2,849	345,9	373,1	162,1	217,4	195,1	204,7	292,1	6
21	26.500	25.250	12 - 0.656	0.900	1130T	10 100	1 800	170	67	168	4,553	345,9	373,1	162,1	217,4	195,1	204,7	298,5	6
				1.000	1140T	26 000	1 650	200	67	217	5,768	384,0	419,9	184,2	254,0	201,2	229,4	336,6	6
				1.000	1150T	36 200	1 500	215	108	276	7,572	453,1	420,6	182,9	269,2	271,3	231,4	349,3	6
24	28.875	27.250	12 - 0.812	0.900	1130T	10 100	1 800	170	67	180	5,987	345,9	373,1	162,1	217,4	195,1	204,7	298,5	6
				1.000	1140T	26 000	1 650	200	67	230	7,332	384,0	419,9	184,2	254,0	201,2	229,4	336,6	6
				1.000	1150T	36 200	1 500	215	108	289	9,174	453,1	420,6	182,9	269,2	271,3	231,4	349,3	6
Machined as Required				1.000	1160T	50 800	1 350	240	121	298 ③	—	501,9	453,4	198,1	304,8	278,4	248,9	393,7	6
				1.250	1170T	67 800	1 225	280	134	409 ③	—	566,9	495,3	215,9	355,6	307,3	273,0	438,2	6

① See page 10 for General Information and Reference Notes.

② Maximum bore is for hub with keyway for rectangular key.

③ For total coupling weight add  $[0,101 \times (AF^2 - U^2) \times T]$  to value shown.

④ Peak torque capacity is two times the published rating. Torque ratings for hubs with bushings differ from those shown, refer to Table 18, page 36.

⑤ Consult Factory for higher speeds.

⑥ Maximum bores are reduced for hubs furnished with an interference fit and a setscrew over the keyway. Refer to Rexnord Engineering Sheet 427-105 for details.

⑦ Minimum bore is the smallest bore to which a Rough Stock Bore (RSB) hub can be bored. Depending upon coupling size, RSB hubs may have only a blind centering hole or a through hole that will permit remachining of the hubs to the minimum bores specified.

# Floating Shaft Type T10/G82

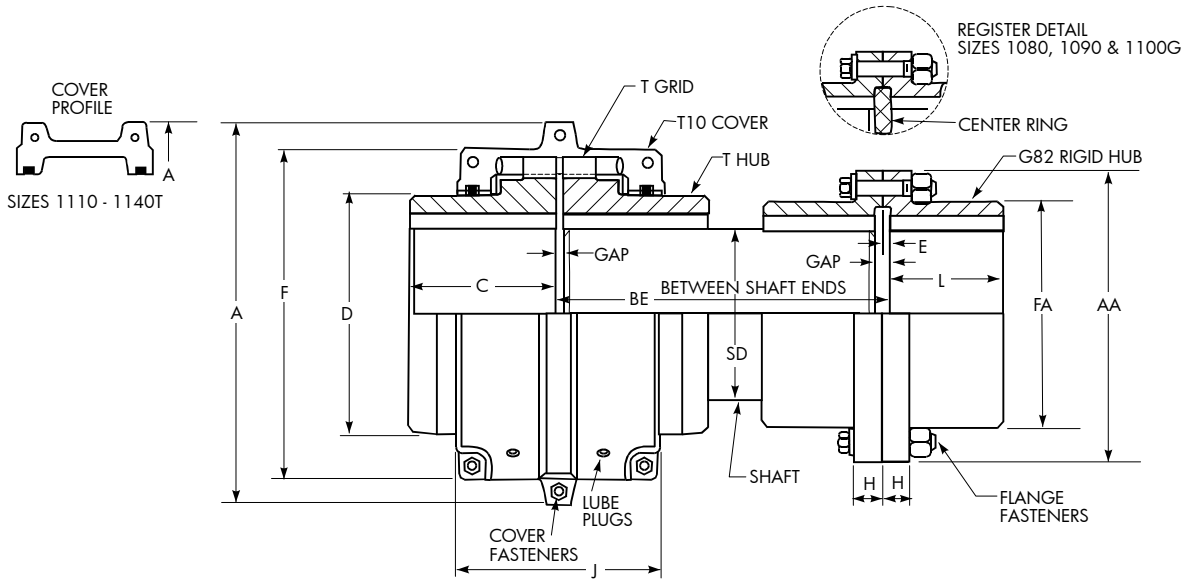

## Dimensions (mm)

T10 Cplg Size ①	G82 Cplg Size ①	Torque Rating (Nm) ③	Allow Speed RPM ④	Max Bore (mm) ⑤		Min Bore (mm) ⑥		Cplg Wt with No Bore & No Shaft (kg)	Wt Added per mm of SD Dia Between Hubs (kg)	Lube Wt (kg)	A	BE		C	D	E	F	H	J	L	AA	FA ②	SD	GAP		Flange Fasteners	
				T10 Hub	G82 Hub	T10 Hub	G82 Hub					Min	Max											T Hub	G82 Hub	No. per Flange & Grade	Dia (in)
1110T	1035G	9 320	2250	120	164	42	51	125	0,0804	0,508	269,7	239,0	304,8	127,0	160,3	2,5	—	28,4	161,5	102,1	279,4	211,3	114,3	5	5	8- GR 8	0.750
1120T	1040G	13 700	2025	140	196	61	64	183	0,0992	0,735	307,8	279,1	355,6	149,2	179,4	4,1	—	28,4	191,5	115,3	317,5	245,4	127,0	6	8	8- GR 8	0.750
1130T	1045G	19 900	1800	170	216	67	76	261	0,143	0,907	345,9	307,1	381,0	161,9	217,5	4,1	—	28,4	195,1	130,6	345,9	274,1	152,4	6	8	10- GR 8	0.750
1140T	1050G	28 600	1650	200	242	67	89	382	0,209	1,13	384,0	348,0	406,4	184,2	254,0	5,1	—	38,1	201,2	147,3	388,9	305,8	184,2	6	10	8- GR 8	0.875
1150T	1055G	39 800	1500	215	267	108	102	508	0,254	1,95	453,1	372,1	406,4	182,9	269,2	5,1	391,2	38,1	271,5	172,7	425,4	334,3	203,2	6	10	14- GR 8	0.875
1160T	1060G	55 900	1350	240	293	121	115	645	0,322	2,81	501,9	404,1	457,2	198,1	304,8	6,6	436,9	25,4	278,4	186,4	457,2	366,0	228,6	6	13	14- GR 8	0.875
1170T	1070G	74 600	1225	280	341	134	127	983	0,397	3,49	566,9	459,2	508,0	215,9	355,6	8,4	487,2	28,4	307,3	220,2	527,0	424,9	254,0	6	17	16- GR 8	1.000
1180T	1080G	103 000	1100	300	341	153	102	1313	0,480	3,76	629,9	510,3	660,4	238,8	393,7	8,1	554,7	31,5	321,1	248,9	590,6	450,8	279,4	6	16	16- GR 8	1.125
1190T	1090G	137 000	1050	335	380	153	115	1756	0,572	4,4	675,6	557,5	711,2	259,1	436,9	8,1	607,8	38,1	325,1	275,8	660,4	508,0	304,8	6	16	18- GR 8	1.250
1200T	1100G	186 000	900	360	405	178	127	2254	0,671	5,62	756,9	609,3	762,0	279,4	497,8	9,1	660,4	44,5	355,6	305,3	711,2	530,4	330,2	6	18	18- GR 8	1.250

- ① Refer to page 10 for General Information.
- ② Dimension FA is for an as-cast, unmachined surface for Sizes 1180, 1190 & 1200.
- ③ Peak torque capacity is two times the published rating. Torque ratings for hubs with bushings differ from those shown, refer to Table 18, page 36.
- ④ Consult Factory for higher speeds.
- ⑤ Maximum bores are reduced for hubs furnished with an interference fit and a setscrew over the keyway. Refer to Rexnord Engineering Sheet 427-105 for details.
- ⑥ Minimum bore is the smallest bore to which a Rough Stock Bore (RSB) hub can be bored. Depending upon coupling size, RSB hubs may have only a blind centering hole or a through hole that will permit remachining of the hubs to the minimum bores specified.



# Engineering Data

**Table 13 — Shaft Diameters & Ratings for NEMA 60 Hertz & 50 Hertz Metric Motors**

Frame Size		NEMA 60 Hertz Motors (HP)																											
		T Frames														TS Frames													
Shaft Dia (in)		143	145	182	184	213	215	254	256	284	286	324	326	364	365	404	405	444	445	284	286	324	326	364	365	404	405	444	445
3600 RPM	Drip Proof	1-1/2	2-3	5	7-1/2	10	15	20	25	30	40	50	60	75	100	125	150	200	250	30	40	50	60	75	100	125	150	200	250
	Enclosed	1-1/2	2	3	5	7-1/2	10	15	20	25	30	40	50	60	75	—	100	125	150	25	30	40	50	60	75	—	100	125	150
1800 RPM	Drip Proof	1	1-1/2, 2	3	5	7-1/2	10	15	20	25	30	40	50	60	75	100	125	150	200	25	30	40	50	60	75	100	125	150	200
	Enclosed	1	1-1/2, 2	3	5	7-1/2	10	15	20	25	30	40	50	60	75	—	100	125	150	25	30	40	50	60	75	—	100	125	150
1200 RPM	Drip Proof & Enclosed	3/4	1	1-1/2	2	3	5	7-1/2	10	15	20	25	30	40	50	60	75	100	125	15	20	25	30	40	50	60	75	100	125
900 RPM	Drip Proof & Enclosed	1/2	3/4	1	1-1/2	2	3	5	7-1/2	10	15	20	25	30	40	50	60	75	100	10	15	20	25	30	40	50	60	75	100

Frame Size		50 Hertz Metric Motors (kW)																	
		80	90S	90L	100L	112M	132S	132M	160M	160L	180M	180L	200M/L	225S	225M	250S	250M	280S	280M
Shaft Dia (mm)		19	24	24	28	28	38	38	42	42	48	48	55	55 60	55 60	60, 65 70	60, 65 70	65, 75 80	65, 75 80
3000 RPM		0,75 1,10	1,5	2,2	3,0	4	5,5 7,5	—	11 15	18,5	22	—	30 37	45	45	55	55 75	75 90	90 110
1500 RPM		0,55 0,75	1,1	1,5	2,2 3,0	4	5,5	7,5	11	15	18,5	22	30	37 45	45	55	55 75	75 90	90 110
1000 RPM		0,37 0,55	0,75	1,1	1,5	2,2	3	4 5,5	7,5	11	—	15	18,5 22	30	30	37	37 45	45 45	55 75
750 RPM		0,18 0,25	0,37	0,55	0,75 1,1	1,5	2,2	3	4 5,5	7,5	—	11	15	18,5	22	30	30 37	37 45	45 55

**OVERHANGING HUBS** — Hubs may be overhung on the shafting, provided there is more than one shaft diameter of hub/shaft engagement for clearance fits, or more than 0.75 times shaft diameter hub/shaft engagement for interference fits. If hub engagement is less than what is required, use a standard long hub listed in **Table 22** on **page 39**, or submit application details to the Factory.

Dimension L must be equal to or greater than Dimension SD for clearance fits, or greater than Dimension SD times 0.75 for interference fits. For Type T63, Dimension Y must be equal to or greater than Dimension X.

**Example:** SD = 100 mm; then L must be 100 mm or more for clearance fits or 75 mm or more for interference fits.

**CAUTION:** The effect of open keyways on coupling balance should be accounted for.

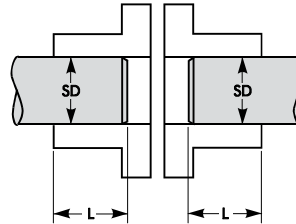

**Example – Type T, Other than T63**

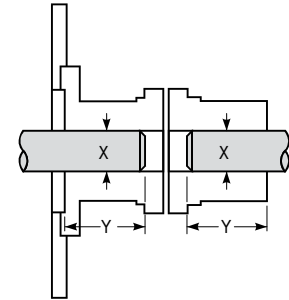

**Example – Type T63**

# Engineering Data

**Table 14 — Type T Hub & Flanged Hub Bore Ranges with Square & Rectangular Keys ③**

Size ①	Inches																Millimeters ⑤			
	Min Bore ⑥	For One Square Key				For One Rectangular Key						For Two Square Keys			For Two Rectangular Keys			Min Bore	Max Bore	
		Max Bore ⑧	Y=X		Max Bore ⑧	Y=X		Max Bore ⑧	Y=W/2 ④		Max Bore ⑧	Y=X		Max Bore ⑧	Y=X		Std Bore Fits per Table 30 ⑥		Int Fit per Table 30 w/ Setscrew Over Keyway	
			W	Y		W	Y		W	Y		W	Y							
20/1020T	0.500	1.125 ②	0.250 ②	0.125 ②	1.187	0.250	0.093	1.250	0.250	0.062	—	—	—	—	—	—	13	28	24	
30/1030T	0.500	1.375 ②	0.312 ②	0.156 ②	1.437	0.375	0.125	1.562	0.375	0.062	—	—	—	—	—	—	13	35	30	
40/1040T	0.500	1.625 ②	0.375 ②	0.187 ②	1.750	0.375	0.125	1.750	0.375	0.062	—	—	—	—	—	—	13	43	38	
50/1050T	0.500	1.875 ②	0.500 ②	0.250 ②	2.000	0.500	0.187	2.125	0.500	0.125	—	—	—	—	—	—	13	50	45	
60/1060T	0.750	2.125 ②	0.500 ②	0.250 ②	2.250	0.500	0.187	2.375	0.625	0.125	—	—	—	—	—	—	20	56	50	
70/1070T	0.750	2.500 ②	0.625 ②	0.312 ②	2.687	0.625	0.218	2.875	0.750	0.125	—	—	—	—	—	—	20	67	60	
80/1080T	1.062	3.000 ②	0.750 ②	0.375 ②	3.250	0.750	0.250	3.375	0.875	0.187	—	—	—	—	—	—	27	80	75	
90/1090T	1.062	3.500 ②	0.875 ②	0.437 ②	3.750	0.875	0.312	3.875	1.000	0.250	—	—	—	—	—	—	27	95	90	
100/1100T	1.625	4.000 ②	1.000 ②	0.500 ②	4.250	1.000	0.375	4.500	1.000	0.250	—	—	—	—	—	—	42	110	100	
110/1110T	1.625	4.500 ②	1.000 ②	0.500 ②	4.625	1.250	0.437	5.000	1.250	0.250	—	—	—	—	—	—	42	120	110	
120/1120T	2.375	5.000 ②	1.250 ②	0.625 ②	5.375	1.250	0.437	5.750	1.500	0.250	—	—	—	—	—	—	61	140	120	
130/1130T	2.625	6.000 ②	1.500 ②	0.750 ②	6.500	1.500	0.500	6.500	1.500	0.250	—	—	—	—	—	—	67	170	150	
140/1140T	2.625	7.000	1.750	0.875	7.250 ②	1.750 ②	0.750 ②	7.750	2.000	0.500	—	—	—	—	—	—	67	200	180	
150/1150T	4.250	7.500	1.750	0.875	8.000 ②	2.000 ②	0.750 ②	—	—	—	—	—	—	—	—	—	108	215	190	
160/1160T	4.750	8.500	2.000	1.000	9.000 ②	2.000 ②	0.750 ②	—	—	—	—	—	—	—	—	—	121	240	215	
170T	5.250	9.750	2.500	1.250	10.000 ②	2.500 ②	0.875 ②	—	—	—	10.750	1.750	0.875	11.000	1.750	0.750	134	280	240	
1180T	6.000	10.750	2.500	1.250	11.000 ②	2.500 ②	0.875 ②	—	—	—	12.000	1.750	0.875	12.250	2.000	0.750	153	300	260	
1190T	6.000	11.750	3.000	1.500	12.000 ②	3.000 ②	1.000 ②	—	—	—	13.000	2.000	1.000	13.250	2.000	0.750	153	336	290	
1200T	7.000	12.750	3.000	1.500	13.000 ②	3.000 ②	1.000 ②	—	—	—	14.000	2.500	1.250	14.250	2.500	0.875	178	360	320	
1210T	7.000	13.750	3.500	1.750	14.000 ②	3.500 ②	1.250 ②	—	—	—	15.000	2.500	1.250	15.250	2.500	0.875	178	390	350	
1220T	8.000	14.750	3.500	1.750	15.000 ②	3.500 ②	1.250 ②	—	—	—	16.000	2.500	1.250	16.250	3.000	1.000	178	420	380	
1230T	8.000	15.750	4.000	2.000	16.000 ②	4.000 ②	1.500 ②	—	—	—	17.000	3.000	1.500	17.250	3.000	1.000	254	450	410	
1240T	10.000	16.750	4.000	2.000	17.000 ②	4.000 ②	1.500 ②	—	—	—	18.000	3.000	1.500	18.250	3.000	1.000	254	480	440	
1250T	10.000	18.000	4.000	2.000	18.500 ②	5.000 ②	1.750 ②	—	—	—	19.250	3.500	1.750	19.750	3.500	1.250 ⑦	⑦	⑦	⑦	
1260T	10.000	19.500	5.000	2.500	20.000 ②	5.000 ②	1.750 ②	—	—	—	20.750	3.500	1.750	21.250	3.500	1.250 ⑦	⑦	⑦	⑦	

**Table 15 — Type T31& T35 Shaft Hub Bore Ranges with Square & Rectangular Keys ③**

Size ①	Inches											Millimeters			
	Min Bore ⑥	For One Square Key				For One Rectangular Key						Min Bore	Max Bore		
		Max Bore ⑧	Y=X		Max Bore ⑧	Y=X		Max Bore ⑧	Y=W/2 ④		Std Bore Fits per Table 30		Int Fit per Table 30 w/Setscrew Over Keyway	With Puller Holes per Table 23 or Table 24	
			W	Y		W	Y		W	Y					
1020T	0.500	1.375 ②	0.312 ②	0.156 ②	1.437	0.375	0.125	1.562	0.375	0.062	13	35	30	35	
1030T	0.500	1.625 ②	0.375 ②	0.188 ②	1.750	0.375	0.125	—	—	—	13	43	38	43	
1040T	0.500	2.125 ②	0.500 ②	0.250 ②	2.250	0.500	0.188	2.375	0.625	0.125	13	56	50	56	
1050T	0.500	2.375 ②	0.625 ②	0.312 ②	2.500	0.625	0.218	2.625	0.625	0.125	13	67	60	67	
1060T	0.750	2.875 ②	0.750 ②	0.375 ②	3.125	0.750	0.250	3.250	0.750	0.125	20	80	76	80	
1070T	0.750	3.125 ②	0.750 ②	0.375 ②	3.250	0.750	0.250	3.375	0.875	0.188	20	85	80	85	
1080T	1.062	3.500 ②	0.875 ②	0.438 ②	3.750	0.875	0.312	3.875	1.000	0.250	27	95	90	88	
1090T	1.062	4.000 ②	1.000 ②	0.500 ②	4.250	1.000	0.375	4.500	1.000	0.250	27	110	100	100	
1100T	1.500	4.750 ②	1.250 ②	0.625 ②	5.000	1.250	0.438	5.250	1.250	0.250	39	130	120	120	
1110T	2.000	5.500 ②	1.250 ②	0.625 ②	5.875	1.500	0.500	6.250	1.500	0.250	51	150	140	140	
1120T	2.500	6.250 ②	1.500 ②	0.750 ②	6.500	1.500	0.500	6.750	1.750	0.625	64	170	165	160	
1130T	3.000	6.750	1.750	0.875	7.000 ②	1.750 ②	0.750 ②	7.250	1.750	0.625	77	190	180	175	
1140T	3.500	7.500	2.000	1.000	8.000 ②	2.000 ②	0.750 ②	8.500	2.000	0.500	89	210	200	200	
1150T	4.000	9.750	2.000	1.000	10.000 ②	2.500 ②	0.875 ②	—	—	—	102	270	230	250	
1160T	4.500	10.500	2.500	1.250	11.000 ②	2.500 ②	0.875 ②	—	—	—	115	290	260	280	
1170T	5.000	12.000	3.000	1.500	13.000 ②	3.000 ②	1.000 ②	—	—	—	127	340	290	330	
1180T	4.000	12.000	3.000	1.500	13.000 ②	3.000 ②	1.000 ②	—	—	—	102	340	310	340	
1190T	4.500	13.250	3.500	1.750	14.250 ②	3.500 ②	1.250 ②	—	—	—	116	380	340	380	
1200T	5.000	14.250	3.500	1.750	15.000 ②	3.500 ②	1.250 ②	—	—	—	127	400	365	400	

- ① Refer to page 10 for general information.  
Metric keyways and keyway radiiuses will be furnished per ISO/R773 (DIN 6885/1) and Js9 width tolerances unless otherwise specified. P9 and D10 width tolerance can be furnished on request. Refer to 427-140 for tolerances.
- ② Shaded areas indicate maximum bores using standard recommended keys shown in Table 26.
- ③ Unless otherwise specified, Sizes 1020 thru 1090 will be furnished for clearance fit with a setscrew over the keyway and Sizes 1100 and larger will be furnished for interference fit without a setscrew. Exception: For Types T50 and T70, coupling hubs are normally furnished with an average interference fit of 0,0005 mm per millimeter of shaft diameter. Clearance fit and/or hubs with setscrews are not recommended.
- ④ Shaft keyway depth Y equals one-half of square key W. **NOTE:** Check key stresses.
- ⑤ Also applies to Hub Type T61, T63, T50 pilot hub and flanged hub of T50 and T70 type couplings.
- ⑥ With standard puller bolt holes per Table 23, page 39.
- ⑦ Consult Rexnord.
- ⑧ Minimum bore is the smallest bore to which a Rough Stock Bore (RSB) hub can be bored. Depending upon coupling size, RSB hubs may have only a blind centering hole or a through hole that will permit remachining of the hubs to the minimum bores specified.
- ⑨ Maximum bores are reduced for hubs furnished with an interference fit and a setscrew over the keyway. Refer to Rexnord Engineering Sheet 427-105 for details.

# Engineering Data

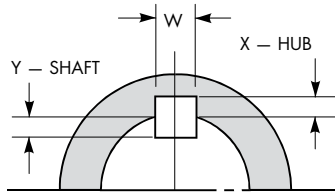

CHECK KEY STRESSES

**Table 16 — T41 Hub Bore Ranges with Square and Rectangular Keys**

Size ①	Inches								Millimeters		
	Min Bore ⑥	For One Square Key		For One Rectangular Key				Min Bore	Max Bore		
		Max Bore ⑦	Y=X		Max Bore ⑦	W	X		Y	Std Bore Fits per Table 30	Int Fit per Table 30 w/ Setscrew Over Keyway
		W	X								
1020T41	0.500	1.000 ④	0.250	0.125	1.125	0.250	0.062	0.125	13	24 ⑤	⑤
1030T41	0.500	1.250 ④	0.250	0.125	1.375	0.312	0.093	0.156	13	32	⑤
1040T41	0.500	1.375 ④	0.312	0.156	1.625	0.375	0.062	0.187	13	38	32
1050T41	0.500	1.750 ④	0.375	0.187	1.875	0.500	0.125	0.250	13	45	40
1060T41	0.750	1.875 ④	0.500	0.250	2.125	0.500	0.125	0.250	20	50	45
1070T41	0.750	2.250 ④	0.500	0.250	2.500	0.625	0.125	0.312	20	60	50
1080T41	1.062	2.625 ④	0.625	0.312	2.750	0.625	0.125	0.312	27	70	65
					3.000	0.750	0.125	0.375	27	70	65
1090T41	1.062	3.125 ④	0.750	0.375	3.250	0.750	0.125	0.375	27	85	80
					3.500	0.875	0.187	0.437	27	85	80
1100T41	1.625	3.625 ④	0.875	0.437	3.750	0.875	0.187	0.437	42	100	90
					4.000	1.000	0.250	0.500	42	100	90
1110T41	1.625	4.000 ④	1.000	0.500	4.500	1.000	0.250	0.500	42	110	100
1120T41	2.375	4.500 ④	1.000	0.500	5.000	1.250	0.250	0.625	61	120	110
1130T41	2.625	5.250 ④	1.250	0.625	5.500	1.250	0.250	0.625	67	145	135
					6.000	1.500	0.250	0.750	67	145	135
1140T41	2.625	6.500 ④	1.500	0.750	7.250 ③	1.750	0.500	0.750	67	180	165
1150T41	4.250	6.750 ②	1.750	0.875	7.000 ④	1.750	0.750	0.750	108	190	180
					7.500 ③	1.750	0.500	0.750	108	190	180
					8.000 ③	2.000	0.375	0.750	108	190	180
1160T41	4.750	7.750 ②	2.000	1.000	8.500 ④	2.000	0.750	0.750	121	225	200
					9.000 ③	2.000	0.500	0.750	121	225	200
1170T41	5.250	9.000 ②	2.000	1.000	9.500 ④	2.500	0.875	0.875	134	250	230
					10.000 ③	2.500	0.500	0.875	134	250	230
1180T41	6.000	10.250 ②	2.500	1.250	11.000 ④	2.500	0.875	0.875	153	290	260
1190T41	6.000	11.000 ②	2.500	1.250	12.000 ④	3.000	1.000	1.000	153	320	285
1200T41	7.000	12.125 ②	3.000	1.500	13.000 ④	3.000	1.000	1.000	178	340	310

**Table 17 — Type G82 Hub (used on T10/G82 assemblies) Bore Ranges with Square & Rectangular Keys**

Size ①	Inches							Millimeters			
	Min Bore ⑥	For One Square Key		For One Rectangular Key			Min Bore	Max Bore			
		Max Bore ⑦	Y=X		Max Bore ⑦	Y=X		Std Bore Fits per Table 30	Int Fit per Table 30 w/ Setscrew Over Keyway	With Puller Holes per Table 24	
		W	X		W	X					
1035G	2.000 ④	5.875 ④	1.500 ④	0.750 ④	6.500	1.500	0.500	51	163	150	150
1040G	2.500	6.750	1.750	0.875	7.250 ④	1.750 ④	0.750 ④	64	196	167	185
1045G	3.000	7.625	1.750	0.875	8.125 ④	2.000 ④	0.750 ④	77	216	190	205
1050G	3.500	8.750	2.000	1.000	9.000 ④	2.000 ④	0.750 ④	89	235	220	228
1055G	4.000	9.750	2.000	1.000	10.000 ④	2.500 ④	0.875 ④	102	266	230	250
1060G	4.500	10.500	2.500	1.250	11.000 ④	2.500 ④	0.875 ④	115	290	260	280
1070G	5.000	12.000	3.000	1.500	13.000 ④	3.000 ④	1.000 ④	127	340	290	330
1080G	4.000	13.000	3.000	1.500	13.250 ④	3.000 ④	1.000 ④	102	340	310	340
1090G	4.500	14.250	3.500	1.750	15.000 ④	3.500 ④	1.250 ④	115	380	340	380
1100G	5.000	15.000	3.500	1.750	15.500 ④	3.500 ④	1.250 ④	127	400	365	400

- ① Refer to page 10 for General Information. Unless otherwise specified, Sizes 1020 thru 1090 will be furnished for clearance fit with a setscrew over the keyway and Sizes 1100 and larger will be furnished for interference fit without a setscrew.
- ② Maximum bore with optional square key.
- ③ A special rectangular key is required.
- ④ Maximum bores using standard recommended keys shown in Table 26.
- ⑤ Interference fit is not recommended.
- ⑥ Minimum bore is the smallest bore to which a Rough Stock Bore (RSB) hub can be bored. Depending upon coupling size, RSB hubs may have only a blind centering hole or a through hole that will permit remachining of the hubs to the minimum bores specified.
- ⑦ Maximum bores are reduced for hubs furnished with an interference fit and a setscrew over the keyway. Refer to Rexnord Engineering Sheet 427-105 for details.

# Engineering Data

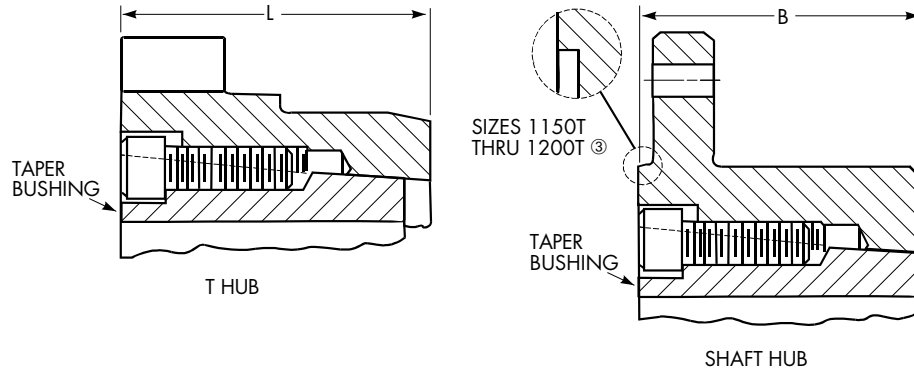

**Table 18 — Taper-Lock Bushings for Type T Hubs & Shaft Hubs ①**

Coupling Size	T Hub				Shaft Hub				
	Taper-Lock Bushing			L (mm)	Taper-Lock Bushing			B (mm)	Gear Cplg Rigid Hub Size
	Bushing Number	Bore Range ② (mm)	Torque (Nm)		Bushing Number	Bore Range ② (mm)	Torque (Nm)		
1020T	—	—	—	—	1108	13 to 25	52	35,1	—
1030T	1108	13 to 25	147	41,1	1108	13 to 25	147	41,1	—
1040T	1108	13 to 25	147	41,1	1310	13 to 35	249	53,8	—
1050T	1215	13 to 32	407	47,8	1615	13 to 42	435	60,4	—
1060T	1615	13 to 42	486	53,8	2012	13 to 50	684	73,2	—
1070T	2012	13 to 50	808	53,8	2525	20 to 65	994	79,2	—
1080T	2525	20 to 65	1 277	66,5	2525	20 to 65	1 277	88,9	—
1090T	3030	24 to 80	2 712	79,2	3030	24 to 80	2 712	101,6	—
1100T	3030	24 to 80	2 712	88,9	3535	31 to 91	5 062	90,4	—
1110T	3535	31 to 91	5 062	91,9	4040	37 to 103	8 734	104,1	—
1120T	4040	37 to 103	8 734	111,3	4545	50 to 114	12 428	119,4	—
1130T	4545	50 to 114	12 428	117,3	5050	61 to 127	14 236	134,6	—
1140T	5050	61 to 127	14 236	130,0	5050	61 to 127	14 236	152,4	—
1150T	5050	61 to 127	14 236	182,9	6050	88 to 152	31 862	172,7 ③	1055
1160T	5050	61 to 127	14 236	198,1	7060	100 to 177	47 002	186,4 ③	1060
1170T	7060	100 to 177	47 002	215,9	8065	117 to 203	51 521	220,2 ③	1070
1180T	8065	117 to 203	51 521	238,8	8065	117 to 203	51 521	248,9 ③	1080
1190T	8065	117 to 203	51 521	259,1	10085	178 to 254	98 184	275,8 ③	1090
1200T	10085	178 to 254	98 184	279,4	10085	178 to 254	98 184	304,8 ③	1100

① Use straight bored hubs for shock load or reversing load applications or applications that require 1.75 or higher coupling service factors or refer to the Factory for selection, price and delivery of special bushings. Refer to Factory for selection of Taper-Lock bushings for Type T50 and T70 couplings.

② Bushings require shaft keyways per ISO R773.

③ For Sizes 1150T thru 1200T, dimension "B" is to the hub counterbore.

# Engineering Data

**Table 19 — WR<sup>2</sup> Values (kg-m<sup>2</sup>)**

(WR<sup>2</sup> values are based on hubs with no bore; seals, lube plugs and gaskets are not considered.)

Coupling Size	Coupling Type											T70
	T10	T20	T31		T35		T10/G82 ①			T50		
			WR <sup>2</sup> (Min BE)	WR <sup>2</sup> Added per Inch of BE Over Minimum	WR <sup>2</sup> (Min BE)	WR <sup>2</sup> Added per Inch of BE Over Minimum	Rigid Hub Size	WR <sup>2</sup> (Without Shaft)	WR <sup>2</sup> Added per Inch of Length of "SD" Diameter Between Hubs	WR <sup>2</sup> (Each Coupling)	WR <sup>2</sup> Added per Inch of Length of "SD" Diameter Between Hubs	
1020T	0,0014	0,0016	0,00286	0,00000207	0,00214	0,00000207	—	—	—	—	—	—
1030T	0,0022	0,0023	0,00449	0,00000484	0,00336	0,00000484	—	—	—	0,00434	0,00000500	0,00434
1040T	0,0033	0,0035	0,00930	0,00000876	0,00629	0,00000876	—	—	—	—	—	—
1050T	0,0073	0,0075	0,0181	0,0000161	0,0127	0,0000161	—	—	—	0,0181	0,00000161	0,0181
1060T	0,012	0,012	0,0387	0,0000274	0,0253	0,0000274	—	—	—	—	—	—
1070T	0,019	0,018	0,0513	0,0000468	0,0349	0,0000468	—	—	—	0,0422	0,00000509	0,0420
1080T	0,045	0,043	0,116	0,0000964	0,0804	0,0000964	—	—	—	0,101	0,0000124	0,101
1090T	0,079	0,080	0,236	0,000187	0,157	0,000187	—	—	—	0,177	0,0000258	0,176
1100T	0,178	0,178	0,514	0,000313	0,346	0,000313	—	—	—	0,417	0,0000629	0,417
1110T	0,270	0,272	0,798	0,000523	0,534	0,000523	1035G	0,787	0,000130	0,699	0,0000916	0,697
1120T	0,514	0,472	1,56	0,000817	1,04	0,000817	1040G	1,51	0,000199	0,801	0,000162	0,800
1130T	0,990	1,05	2,51	0,00176	1,75	0,00176	1045G	2,56	0,000412	1,42	0,000266	1,42
1140T	1,85	1,88	4,35	0,00326	3,10	0,00326	1050G	4,78	0,000879	2,81	0,000348	2,80
1150T	3,49	3,29	9,00	0,00276	6,24	0,00276	1055G	8,23	0,00130	3,04	0,000559	—
1160T	5,82	6,03	12,8	0,00454	9,90	0,00454	1060G	12,1	0,00209	9,13	0,00130	—
1170T	10,4	10,4	24,8	0,00909	17,6	0,00909	1070G	23,7	0,00318	15,0	0,00130	—
1180T	18,3	—	39,7	0,0138	29,0	0,0138	1080G	38,3	0,00466	25,8	0,00209	—
1190T	26,2	—	65,0	0,0214	45,6	0,0214	1090G	62,2	0,00659	36,9	0,00318	—
1200T	43,6	—	93,5	0,0381	68,5	0,0381	1100G	92,7	0,00908	59,8	0,00466	—
1210T	75,6	—	—	—	—	—	—	—	—	—	—	—
1220T	113	—	—	—	—	—	—	—	—	—	—	—
1230T	175	—	—	—	—	—	—	—	—	—	—	—
1240T	339	—	—	—	—	—	—	—	—	—	—	—
1250T	525	—	—	—	—	—	—	—	—	—	—	—
1260T	712	—	—	—	—	—	—	—	—	—	—	—

① Values shown are for standard hub lengths.

## Coupling Misalignment

Maximum life and minimum maintenance for the coupling and connected machinery will result if couplings are accurately aligned. Coupling life expectancy between initial alignment and maximum operating limits is a function of load, speed and lubrication. For applications requiring greater misalignment, refer application details to Rexnord.

**Angular misalignment** is expressed in degrees and as the difference between the value of X minus Y, as illustrated.

**Parallel misalignment** is the distance P between shaft center lines as shown.

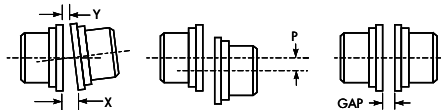

**Table 20 — Misalignment Capacity (mm) ②**

Cplg Size	Recommended Installation Maximum				Maximum Operating			Normal Gap ± 10%	
	Parallel Offset – P			Angular (1/16°) X Minus Y	Parallel Offset – P ③		Angular (1/4°) X Minus Y	All Types Except T31	Type T31
	Types T10, T20, T31, T35, T41, T63	Type T50	Type T70		Types T10, T20, T31, T35, T41, T63	Type T70			
20/1020T	0,15	—	—	0,08	0,30	—	0,25	3	5
30/1030T	0,15	0,05	0,08	0,08	0,30	0,15	0,30	3	5
40/1040T	0,15	—	—	0,08	0,30	—	0,33	3	5
50/1050T	0,20	0,05	0,10	0,10	0,41	0,20	0,41	3	5
60/1060T	0,20	—	—	0,13	0,41	—	0,46	3	5
70/1070T	0,20	0,05	0,10	0,13	0,41	0,20	0,51	3	5
80/1080T	0,20	0,05	0,10	0,15	0,41	0,20	0,61	3	5
90/1090T	0,20	0,08	0,10	0,18	0,41	0,20	0,71	3	5
100/1100T	0,25	0,08	0,13	0,20	0,51	0,25	0,84	5	6
110/1110T	0,25	0,08	0,13	0,23	0,51	0,25	0,91	5	6
120/1120T	0,28	0,08	0,15	0,25	0,56	0,28	1,02	6	10
130/1130T	0,28	0,10	0,15	0,30	0,56	0,28	1,19	6	10
140/1140T	0,28	0,10	0,15	0,33	0,56	0,28	1,35	6	10
150/1150T	0,30	0,10	0,15	0,41	0,61	0,30	1,57	6	10
160/1160T	0,30	0,13	0,15	0,46	0,61	0,30	1,78	6	10
170/1170T	0,30	0,13	0,15	0,51	0,61	0,30	2,01	6	10
180/1180T	0,38	0,13	0,20	0,56	0,76	0,38	2,26	6	10
190/1190T	0,38	0,15	0,20	0,61	0,76	0,38	2,46	6	10
200/1200T	0,38	0,15	0,20	0,69	0,76	0,38	2,72	6	10
1210T	0,46	—	—	0,74	0,91	—	3,00	13	—
1220T	0,46	—	—	0,81	0,91	—	3,28	13	—
1230T	0,46	—	—	0,89	0,97	—	3,61	13	—
1240T	0,48	—	—	0,97	0,97	—	3,91	13	—
1250T	0,51	—	—	1,07	1,02	—	4,29	13	—
1260T	0,51	—	—	1,17	1,02	—	4,65	13	—

② Values may be combined for an installation or an operating condition.

③ Operating offset limits between Type T50 floating shaft assembly is a function of 1/4° and distance between shaft ends.

# Engineering Data

## Mill Motor and Taper Bore Dimensions — Millimeters

Standardized for AISE mill motors. Also available for use on other tapered shaft applications such as large pumps, compressors and turbines.

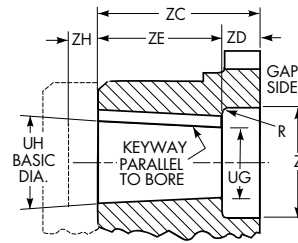

Type T Hub or T31/T35 Shaft Hubs Only

Table 21 — Standard AISE AC & DC Mill Motor Coupling Selections (mm)

Motor Frame Sizes			Cplg Size ①	R	Z	UG	UH	Keyway	ZC	ZD	ZE	ZH +.XXX -.000
2 602	802 A, B & C	AC 1, 2 & 4	1060T	3,0	66,68	36,50	44,46	12,70 x 6,35	100,1	23,9	76,2	0,61
			1070T	3,0	66,68							
			1080T	7,9	88,90							
			1090T	7,9	88,90							
			1100T	7,9	88,90							
603 604	803 804	—	1070T	3,0	76,20	41,53	50,80	19,05 x 6,35	114,3	25,4	88,9	0,74
			1080T	9,7	101,60							
			1090T	9,7	101,60							
			1100T	9,7	101,60							
606	806	AC 8 & 12	1080T	3,0	88,90	52,91	63,50	12,70 x 6,35	130,0	28,4	101,6	0,74
			1090T	9,7	114,30							
			1100T	9,7	114,30							
			1110T	9,7	114,30							
608	808	—	1090T	3,0	111,13	64,29	76,20	19,05 x 6,35	146,0	31,8	114,3	0,74
			1100T	12,7	136,53							
			1110T	12,7	136,53							
			1120T	12,7	136,53							
610	810	AC18	1100T	3,0	127,00	70,64	82,55	19,05 x 6,35	149,4	35,1	114,3	0,86
			1110T	12,7	152,40							
			1120T	12,7	152,40							
			1130T	12,7	152,40							
612	812	AC 25 & 30	1100T	3,0	133,35	78,84	92,08	19,05 x 6,35	165,1	38,1	127,0	0,86
			1110T	3,0	133,35							
			1120T	3,0	158,75							
			1130T	3,0	158,75							
			1140T	3,0	158,75							
614	814	AC 40 & 50	1110T	3,0	149,23	94,72	107,95	25,40 x 9,53	168,1	41,1	127,0	0,86
			1120T	3,0	149,23							
			1130T	12,7	171,45							
			1140T	12,7	171,45							
616	816	—	1120T	3,0	165,10	102,92	117,48	31,75 x 9,53	184,2	44,4	139,7	0,86
			1130T	15,7	203,20							
			1140T	15,7	203,20							
618	818	—	1130T	3,0	177,80	111,13	127,00	31,75 x 12,70	185,7	33,3	152,4	0,97
			1140T	15,7	215,90							
			1150T	15,7	215,90							
620	—	—	1140T	6,4	222,25	131,37	147,98	38,05 x 19,05	204,0	44,4	159,5	0,97
			1150T	19,0	247,65							
			1160T	19,0	247,65							
622	—	—	1140T	6,4	222,25	139,57	154,51	38,10 x 19,05	204,0	60,5	143,5	0,97
			1150T	19,0	247,65							
			1160T	19,0	247,65							
			1170T	19,0	247,65							
			1170T	19,0	247,65							
624	—	—	1140T	6,4	222,25	153,34	168,28	38,05 x 19,05	204,0	60,5	143,5	0,97
			1150T	19,0	247,65							
			1160T	19,0	247,65							
			1170T	19,0	247,65							
			1180T	19,0	247,65							
			1180T	19,0	247,65							
			1190T	19,0	247,65							

① Coupling selections are based on coupling bore capacity and standard available hub lengths. Check coupling rating for all selections, and hub key stress for mill motor selections 620 and larger.

## Engineering Data

**Table 22** specifies the taper and counter bore limitations for the usual requirements. Refer applications for counter bore diameters or depths which exceed any of these limitations, and requirements for hubs longer than those listed, to Rexnord with full particulars for review.

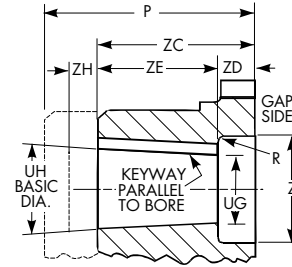

Type T Hub or T31/T35 Shaft Hubs Only ①

**Table 22 — Taper & Counter Bore Limitations (mm) ①**

Size	Std Long Hub Length P Max ②	R	Z Max	UG Min	UH Max	ZD Max	Key ③
20/1020T	98,6	3,0	36,53	13	28	15,7	8 x 7
30/1030T	104,6	3,0	46,02	13	35	15,7	10 x 8
40/1040T	104,6	3,0	53,98	13	45	15,7	12 x 8
50/1050T	165,1	6,4	65,07	13	50	20,6	14 x 9
60/1060T	167,4	6,4	73,03	20	56	20,6	16 x 10
70/1070T	167,4	6,4	84,12	20	67	22,4	20 x 12
80/1080T	205,5	9,7	103,17	27	80	31,8	22 x 14
90/1090T	205,5	9,7	117,48	27	95	35,1	25 x 14
100/1100T	204,7	12,7	136,53	42	110	42,9	28 x 16
110/1110T	204,7	12,7	152,40	42	120	44,5	32 x 18
120/1120T	204,0	15,7	165,10	61	140	50,8	36 x 20
130/1130T	204,0	15,7	203,20	67	170	52,3	40 x 22
140/1140T	204,0	19,1	234,95	67	200	57,2	45 x 25
150/1150T	182,9	19,1	266,70	108	215	63,5	50 x 28
160/1160T	198,1	19,1	304,80	121	240	69,9	56 x 32
1170T	215,9	19,1	355,60	134	280	76,2	63 x 32

**Table 23 — Type T Steelflex Coupling Puller Bolt Holes (mm)**

Size	T-Hub		Shaft Hub	
	B.C.	Tap Size – 6H	B.C. ④	Tap Size – 6H
1020T	39	M4 x 0,7 x 10	71	M10 x 1,5 x ⑤
1030T	47	M4 x 0,7 x 10	79	M10 x 1,5 x ⑤
1040T	54	M4 x 0,7 x 10	98	M10 x 1,5 x ⑤
1050T	63	M5 x 0,8 x 10	108	M10 x 1,5 x ⑤
1060T	73	M6 x 1,0 x 10	125	M10 x 1,5 x ⑤
1070T	84	M6 x 1,0 x 10	133	M10 x 1,5 x ⑤
1080T	100	M6 x 1,0 x 10	103	M10 x 1,5 x 13
1090T	116	M8 x 1,25 x 11	117	M10 x 1,5 x 13
1100T	133	M8 x 1,25 x 13	146	M16 x 2,0 x 21
1110T	149	M10 x 1,5 x 16	166	M16 x 2,0 x 21
1120T	168	M10 x 1,5 x 16	190	M20 x 2,5 x 24
1130T	197	M16 x 2,0 x 21	208	M20 x 2,5 x 24
1140T	236	M16 x 2,0 x 21	235	M20 x 2,5 x 24
1150T	263	M16 x 2,0 x 24	—	—
1160T	298	M22 x 2,5 x 27	—	—
1170T	338	M30 x 3,5 x 32	—	—
1180T	378	M30 x 3,5 x 38	—	—
1190T	413	M36 x 4,0 x 45	—	—
1200T	456	M36 x 4,0 x 45	—	—
1210T	497	M36 x 4,0 x 45	—	—
1220T	541	M36 x 4,0 x 45	—	—
1230T	586	M36 x 4,0 x 45	—	—
1240T	633	M36 x 4,0 x 45	—	—
1250T	690	M36 x 4,0 x 45	—	—
1260T	749	M36 x 4,0 x 45	—	—

① Refer to Rexnord for other hubs.

② Standard long hub length available for Type T Hubs and flanged hubs; consult Factory for longer lengths.

③ Keyway shown is for maximum bore.

④ Locate puller bolt holes 90° from keyway except as noted by Footnote ⑤.

⑤ Drill and tap thru flange between existing holes. Relation to keyway may vary freely.

⑥ See **page 10** for General Information.

⑦ 1000T series information also applies to 10T series, e.g., 1020=20.

⑧ Also applies to hub Types T61, T63, T50 pilot hub and flanged hub of Types T50 & T70 couplings.

⑨ Interference fit is not recommended.

**Table 24 — Type G Gear Coupling Rigid Hub Puller Bolt Holes (mm)**

Size ⑥	B.C. Rigid Hub	Tap Size 6H
1035G	182,37	M12 x 1,75 x 16
1040G	209,80	M16 x 2,0 x 20
1045G	233,17	M16 x 2,0 x 20
1050G	259,08	M20 x 2,5 x 22
1055G	284,48	M20 x 2,5 x 22
1060G	316,48	M20 x 2,5 x 22
1070G	368,30	M24 x 3,0 x 30
1080G	400,05	M24 x 3,0 x 30
1090G	457,20	M30 x 3,5 x 38
1100G	471,47	M36 x 4,0 x 45
1110G	520,70	M36 x 4,0 x 45

**Table 25 — Reduced Max Bores Interference Fit & Setscrew Over Keyway — All Type T Couplings (mm)**

Size ⑦	T ⑧	T41 Hub	Shaft Hub for T31 & T35
1020T	25.40	⑨	31.75
1030T	31.75	⑨	38.10
1040T	34.93	31.75	50.80
1050T	44.45	38.10	53.98
1060T	47.63	44.45	69.85
1070T	57.15	53.98	73.03
1080T	69.85	60.33	82.55
1090T	82.55	73.03	95.25
1100T	88.90	82.55	114.30
1110T	101.60	95.25	127.00
1120T	114.30	107.95	152.40
1130T	139.70	127.00	165.10
1140T	165.10	149.23	190.50
1150T	177.80	165.10	222.25
1160T	203.20	190.50	247.65
1170T	228.60	225.43	279.40
1180T	247.65	247.65	298.45
1190T	273.05	273.05	330.20
1200T	298.45	298.45	342.90

# Engineering Data

**Table 26 — Recommended Commercial Keys for Bores with One Key (in/mm)**

Inches (Per ANSI B17.1 Standard)											
Shaft Dia		Key	Shaft Dia		Key	Shaft Dia		Key	Shaft Dia		Key
Over	Through		Over	Through		Over	Through		Over	Through	
0.438	0.562	0.125 x 0.125	1.750	2.250	0.500 x 0.500	4.500	5.500	1.250 x 1.250	11.000	13.000	3.000 x 2.000
0.562	0.875	0.188 x 0.188	2.250	2.750	0.625 x 0.625	5.500	6.500	1.500 x 1.500	13.000	15.000	3.500 x 2.500
0.875	1.250	0.250 x 0.250	2.750	3.250	0.750 x 0.750	6.500	7.500	1.750 x 1.500	15.000	18.000	4.000 x 3.000
1.250	1.375	0.312 x 0.312	3.250	3.750	0.875 x 0.875	7.500	9.000	2.000 x 1.500	18.000	20.000	5.000 x 3.500
1.375	1.750	0.375 x 0.375	3.750	4.500	1.000 x 1.000	9.000	11.000	2.500 x 1.750	—	—	—

Millimeters (Per ISO R773 Standard)											
Shaft Dia	Key	Shaft Dia	Key	Shaft Dia	Key	Shaft Dia	Key	Shaft Dia	Key	Shaft Dia	Key
6	8	2 x 2	38	44	12 x 8	95	110	28 x 16	260	290	63 x 32
8	10	3 x 3	44	50	14 x 9	110	130	32 x 18	290	330	70 x 36
10	12	4 x 4	50	58	16 x 10	130	150	36 x 20	330	380	80 x 40
12	17	5 x 5	58	65	18 x 11	150	170	40 x 22	380	440	90 x 45
17	22	6 x 6	65	75	20 x 12	170	200	45 x 25	440	500	100 x 50
22	30	8 x 7	75	85	22 x 14	200	230	50 x 28	—	—	—
30	38	10 x 8	85	95	25 x 14	230	260	56 x 32	—	—	—

**Table 27 — Standard Bore Fits — Unless Otherwise Specified, Falk Coupling Hubs Will Be Bored with the Following Bore Fits:**

Model	Coupling Size	Coupling Type	Bore Fit
Steelex Grid Couplings	1020 - 1090	T10, T20, T31, T35, T41	Clearance
	1100 and Larger	All Types	Interference
	All Sizes	T50, T63, T70, T90	Interference

**Table 28 — Recommended Bores for Steel Hubs (in)**

Shaft Dia	Clearance Fit		Interference Fit		Shaft Dia	Clearance Fit		Interference Fit		Shaft Dia	Clearance Fit		Interference Fit		Shaft Dia	Interference Fit	
	Hub Bore	Clearance	Hub Bore	Interference		Hub Bore	Clearance	Hub Bore	Interference		Hub Bore	Clearance	Hub Bore	Interference		Hub Bore	Interference
+ .0000	+ .0010	.0000	+ .0005	.0000	+ .0000	+ .0015	.0000	+ .0010	.0000	+ .0000	+ .0015	.0000	+ .0015	.0010	+ .0000	+ .0015	.0015
- .0005	- .0000	.0015	- .0000	.0010	- .0010	- .0000	.0025	- .0000	.0020	- .0010	- .0000	.0025	- .0000	.0035	- .0010	- .0000	.0040
0.5000	0.5000		0.4990		2.2500	2.2500		2.2480		4.0625	4.0625		4.0590		6.7500	6.7460	
0.5625	0.5625		0.5615		3.3125	3.3125		3.3105		4.1250	4.1250		4.1215		7.0000	6.9960	
0.6250	0.6250		0.6240		2.3750	2.3750		2.3730		4.1875	4.1875		4.1840		<b>+ .0000</b>	<b>+ .0020</b>	<b>.0020</b>
0.6875	0.6875		0.6865		2.4375	2.4375		2.4355		4.2500	4.2500		4.2465		- .0010	- .0000	<b>.0050</b>
0.7500	0.7500		0.7490		2.5000	2.5000		2.4980		4.3125	4.3125		4.3090		7.250	7.2450	
0.8125	0.8125		0.8115		2.5625	2.5625		2.5605		4.3750	4.3750		4.3715		7.500	7.4950	
0.8750	0.8750		0.8740		2.6250	2.6250		2.6230		4.4375	4.4375		4.4340		7.750	7.7450	
0.9375	0.9375		0.9365		2.6875	2.6875		2.6855		4.5000	4.5000		4.4965		8.000	7.9950	
1.0000	1.0000		0.9990		2.7500	2.7500		2.7480		4.5625	4.5625		4.5590		8.250	8.2445	<b>.0025</b>
1.0625	1.0625		1.0615		2.8125	2.8125		2.8105		4.6250	4.6250		4.6215		8.500	8.4945	<b>.0055</b>
1.1250	1.1250		1.1240		2.8750	2.8750		2.8730		4.6875	4.6875		4.6840		8.750	8.7445	
1.1875	1.1875		1.1865		2.9375	2.9375		2.9355		4.7500	4.7500		4.7465		9.000	8.9945	
1.2500	1.2500		1.2490		3.0000	3.0000		2.9980		4.8125	4.8125		4.8090		9.250	9.2440	<b>.0030</b>
1.3125	1.3125		1.3115		<b>+ .0000</b>	<b>+ .0015</b>	<b>.0000</b>	<b>+ .0010</b>	<b>.0005</b>	4.8750	4.8750		4.8715		9.500	9.4940	<b>.0060</b>
1.3750	1.3750		1.3740		- .0010	- .0000	<b>.0025</b>	- .0000	<b>.0025</b>	4.9375	4.9375		4.9340		9.750	9.7440	
1.4375	1.4375		1.4365		3.0625	3.0625		3.0600		5.0000	5.0000		4.9965		10.000	9.9940	
1.5000	1.5000		1.4990		3.1250	3.1250		3.1225		5.0625	5.0625		5.0585	<b>.0015</b>	10.250	10.2435	<b>.0035</b>
<b>+ .0000</b>	<b>+ .0010</b>	<b>.0000</b>	<b>+ .0005</b>	<b>.0000</b>	3.1875	3.1875		3.1850		5.1250	5.1250		5.1210	<b>.0040</b>	10.500	10.4935	<b>.0065</b>
- .0010	- .0000	<b>.0020</b>	- .0000	<b>.0015</b>	3.2500	3.2500		3.2475		5.1875	5.1875		5.1835		10.750	10.7435	
1.5625	1.5625		1.5610		3.3125	3.3125		3.3100		5.2500	5.2500		5.2460		11.000	10.9935	
1.6250	1.6250		1.6235		3.3750	3.3750		3.3725		5.3125	5.3125		5.3085		11.250	11.2430	<b>.0040</b>
1.6875	1.6875		1.6860		3.4375	3.4375		3.4350		5.3750	5.3750		5.3710		11.500	11.4930	<b>.0070</b>
1.7500	1.7500		1.7485		3.5000	3.5000		3.4975		5.4375	5.4375		5.4335		11.750	11.7430	
1.8125	1.8125		1.8110		3.5625	3.5625		3.5600		5.5000	5.5000		5.4960		12.000	11.9930	
1.8750	1.8750		1.8735		3.6250	3.6250		3.6225		5.5625	5.5625		5.5585		12.500	12.4925	<b>.0045</b>
1.9375	1.9375		1.9360		3.6875	3.6875		3.6850		5.6250	5.6250		5.6210		13.000	12.9925	<b>.0075</b>
2.0000	2.0000		1.9985		3.7500	3.7500		3.7475		5.6875	5.6875		5.6835		13.500	13.4920	<b>.0050</b>
<b>+ .0000</b>	<b>+ .0015</b>	<b>.0000</b>	<b>+ .0005</b>	<b>.0000</b>	3.8125	3.8125		3.8100		5.7500	5.7500		5.7460		14.000	13.9920	<b>.0080</b>
- .0010	- .0000	<b>.0025</b>	- .0000	<b>.0015</b>	3.8750	3.8750		3.8725		5.8125	5.8125		5.8085		14.500	14.4915	<b>.0055</b>
2.0625	2.0625		2.0610		3.9375	3.9375		3.9350		5.8750	5.8750		5.8710		15.000	14.9915	<b>.0085</b>
2.1250	2.1250		2.1235		4.0000	4.0000		3.9975		5.9375	5.9375		5.9335		<b>+ .000</b>	<b>+ .0025</b>	<b>.0055</b>
2.1875	2.1875		2.1860							6.0000	6.0000		5.9960		- .001	- .0000	<b>.0090</b>
										6.2500	6.2500		6.2460		15.500	15.4910	
										6.5000	6.5000		6.4960		16.000	15.9910	
															16.500	16.4905	<b>.0060</b>
															17.000	16.9905	<b>.0095</b>
															17.500	17.4895	<b>.0070</b>
															18.000	17.9895	<b>.0105</b>
															18.500	18.4890	<b>.0075</b>
															19.000	18.9890	<b>.0110</b>
															19.500	19.4880	<b>.0085</b>
															20.000	19.9880	<b>.0120</b>



# Engineering Data

**Table 29 — Recommended Bore Tolerances Falk Steel Coupling Hubs — Millimeters**

Shaft Diameter (ISO/R775-1969)		Bore Diameter Tolerance		
Nominal	Tolerance	Clearance	Transitional	Interference
6 to 30	j6 / k6 ①	F7	H7	M6
Over 30 to 50	k6	F7	H7	K6
Over 50 to 80	m6	F7	H7	K7
Over 80 to 100	m6	F7	H7	M7
Over 100 to 200	m6	F7	H7	P7
Over 200 to 355	m6	F7	H7	R7
Over 355 to 500	m6	F7	H7	R8

① Per DIN 748 — Differs from ISO/R775.

**Table 30 — Recommended Bores for Metric Shafts per ISO/R775-1969 (ANSI/AGMA 9112) (mm) ②**

	Shaft Diameter	Clearance Fit		Transitional Fit		Interference Fit	
		Hub Bore	Fit ③	Hub Bore	Fit ③	Hub Bore	Fit ③
<b>MM</b>	<b>j6</b> <b>+ .008 / - .003</b>	<b>F7</b> <b>+ .016 / + .034</b>	<b>+ .008</b> <b>+ .037</b>	<b>H7</b> <b>+ .000 / + .018</b>	<b>- .008</b> <b>+ .021</b>	<b>M6</b> <b>- .015 / - .004</b>	<b>- .023</b> <b>- .001</b>
12	12.008/11.997	12.016/12.034	↓	12.000/12.018	↓	11.985/11.996	↓
14	14.008/13.997	14.016/14.034	↓	14.000/14.018	↓	13.985/13.996	↓
16	16.008/15.997	16.016/16.034	↓	16.000/16.018	↓	15.985/15.996	↓
18	18.008/17.997	18.016/18.034	↓	18.000/18.018	↓	17.985/17.996	↓
<b>MM</b>	<b>j6</b> <b>+0.009 / - .004</b>	<b>F7</b> <b>+ .020 / + .041</b>	<b>+ .011</b> <b>+ .045</b>	<b>H7</b> <b>+ .000 / + .021</b>	<b>- .009</b> <b>+ .025</b>	<b>M6</b> <b>- .017 / - .004</b>	<b>- .026</b> <b>+ .000</b>
19	19.009/18.996	19.020/19.041	↓	19.020/19.041	↓	18.983/18.996	↓
20	20.009/19.996	20.020/20.041	↓	20.020/20.041	↓	20.983/20.996	↓
22	22.009/21.996	22.020/22.041	↓	22.020/22.041	↓	21.983/21.996	↓
24	24.009/23.996	24.020/24.041	↓	24.020/24.041	↓	23.983/23.996	↓
25	25.009/24.996	25.020/25.041	↓	25.020/25.041	↓	24.983/24.996	↓
28	28.009/27.996	28.020/28.041	↓	28.020/28.041	↓	27.983/27.996	↓
30	30.009/29.996	30.020/30.041	↓	30.020/30.041	↓	29.983/29.996	↓
<b>MM</b>	<b>k6</b> <b>+ .018 / + .002</b>	<b>F7</b> <b>+ .025 / + .050</b>	<b>+ .007</b> <b>+ .048</b>	<b>H7</b> <b>+ .000 / + .025</b>	<b>- .018</b> <b>+ .023</b>	<b>K6</b> <b>- .013 / + .003</b>	<b>- .031</b> <b>+ .001</b>
32	32.018/32.002	32.025/32.050	↓	32.000/32.025	↓	31.987/32.003	↓
35	35.018/35.002	35.025/35.050	↓	35.000/35.025	↓	34.987/35.003	↓
38	38.018/38.002	38.025/38.050	↓	38.000/38.025	↓	37.987/38.003	↓
40	40.018/40.002	40.025/40.050	↓	40.000/40.025	↓	39.987/40.003	↓
42	42.018/42.002	42.025/42.050	↓	42.000/42.025	↓	41.987/42.003	↓
45	45.018/45.002	45.025/45.050	↓	45.000/45.025	↓	44.987/45.003	↓
48	48.018/48.002	48.025/48.050	↓	48.000/48.025	↓	47.987/48.003	↓
50	50.018/50.002	50.025/50.050	↓	50.000/50.025	↓	49.987/50.003	↓
<b>MM</b>	<b>m6</b> <b>+ .030 / + .011</b>	<b>F7</b> <b>+ .030 / + .060</b>	<b>+ .000</b> <b>+ .049</b>	<b>H7</b> <b>+ .000 / + .030</b>	<b>- .030</b> <b>+ .019</b>	<b>K7</b> <b>- .021 / + .009</b>	<b>- .051</b> <b>- .002</b>
55	55.030/55.011	55.030/55.060	↓	55.000/55.030	↓	54.975/55.009	↓
56	56.030/56.011	56.030/56.060	↓	56.000/56.030	↓	55.975/56.009	↓
60	60.030/60.011	60.030/60.060	↓	60.000/60.030	↓	59.975/60.009	↓
63	63.030/63.011	63.030/63.060	↓	63.000/63.030	↓	62.975/63.009	↓
65	65.030/65.011	65.030/65.060	↓	65.000/65.030	↓	64.975/65.009	↓
70	70.030/70.011	70.030/70.060	↓	70.000/70.030	↓	69.975/70.009	↓
71	71.030/71.011	71.030/71.060	↓	71.000/71.030	↓	70.975/71.009	↓
75	75.030/75.011	75.030/75.060	↓	75.000/75.030	↓	74.975/75.009	↓
80	80.030/80.011	80.030/80.060	↓	80.000/80.030	↓	79.975/80.009	↓
<b>MM</b>	<b>m6</b> <b>+ .035 / + .013</b>	<b>F7</b> <b>+ .036 / + .071</b>	<b>+ .001</b> <b>+ .058</b>	<b>H7</b> <b>+ .000 / + .035</b>	<b>- .035</b> <b>+ .022</b>	<b>M7</b> <b>- .035 / + .000</b>	<b>- .070</b> <b>- .013</b>
85	85.035/85.013	85.036/85.071	↓	85.000/85.035	↓	84.965/85.000	↓
90	90.035/90.013	90.036/90.071	↓	90.000/90.035	↓	89.965/90.000	↓
95	95.035/95.013	95.036/95.071	↓	95.000/95.035	↓	94.965/95.000	↓
100	100.035/100.013	100.036/100.071	↓	100.000/100.035	↓	99.965/100.000	↓
<b>MM</b>	<b>m6</b> <b>+ .035 / + .013</b>	<b>F7</b> <b>+ .036 / + .071</b>	<b>+ .000</b> <b>+ .035</b>	<b>H7</b> <b>+ .000 / + .035</b>	<b>- .059 / - .024</b>	<b>P7</b> <b>- .059 / - .024</b>	<b>- .094</b> <b>- .037</b>
110	110.035/110.013	110.036/110.071	↓	110.000/110.035	↓	109.941/109.976	↓
120	120.035/120.013	120.036/120.071	↓	120.000/120.035	↓	119.941/119.976	↓
<b>MM</b>	<b>m6</b> <b>+ .040 / + .015</b>	<b>F7</b> <b>+ .043 / + .083</b>	<b>+ .003</b> <b>+ .068</b>	<b>H7</b> <b>+ .000 / + .040</b>	<b>- .040</b> <b>+ .025</b>	<b>P7</b> <b>- .068 / - .028</b>	<b>- .108</b> <b>- .043</b>
125	125.040/125.015	125.043/125.083	↓	125.000/125.040	↓	124.932/124.972	↓
130	130.040/130.015	130.043/130.083	↓	130.000/130.040	↓	129.932/129.972	↓
140	140.040/140.015	140.043/140.083	↓	140.000/140.040	↓	139.932/139.972	↓
150	150.040/150.015	150.043/150.083	↓	150.000/150.040	↓	149.932/149.972	↓
160	160.040/160.015	160.043/160.083	↓	160.000/160.040	↓	159.932/159.972	↓
170	170.040/170.015	170.043/170.083	↓	170.000/170.040	↓	169.932/169.972	↓
180	180.040/180.015	180.043/180.083	↓	180.000/180.040	↓	179.932/179.972	↓

② Dimensions shaded are in millimeters.

③ Positive values are clearance, negative values are interference. For reference only.

Continued on page 42.

# Engineering Data

**Table 30 — Recommended Bores for Metric Shafts per ISO/R775–1969 (ANSI/AGMA 9112) ① (Continued)**

	Shaft Diameter	Clearance Fit		Transitional Fit		Interference Fit					
		Hub Bore	Fit ②	Hub Bore	Fit ②	Hub Bore	Fit ②				
>180	<b>m6</b>	<b>F7</b>	<b>+ .004</b>	<b>H7</b>	<b>- .046</b>	<b>P7</b>	<b>- .125</b>				
<b>MM</b>	<b>+ .046 / + .017</b>	<b>+ .050 / + .096</b>	<b>+ .079</b>	<b>+ .000 / + .046</b>	<b>+ .029</b>	<b>- .079 / - .033</b>	<b>- .050</b>				
190	190.046/190.017	190.050/190.096	↓	190.000/190.046	↓	189.921/189.967	↓				
200	200.046/200.017	200.050/200.096		200.000/200.046		199.921/199.967					
>200	<b>m6</b>	<b>F7</b>		<b>H7</b>		<b>R7</b>		<b>- .155</b>			
<b>MM</b>	<b>+ .046 / + .017</b>	<b>+ .050 / + .096</b>		<b>+ .000 / + .046</b>		<b>- .109 / - .063</b>		<b>- .080</b>			
210	210.046/210.017	210.050/210.096		210.000/210.046		209.891/209.937		↓			
220	220.046/220.017	220.050/220.096		220.000/220.046		219.891/219.937					
225	225.046/225.017	225.050/225.096		225.000/225.046		224.891/224.937					
>225	<b>m6</b>	<b>F7</b>		<b>H7</b>		<b>R7</b>			<b>- .159</b>		
<b>MM</b>	<b>+ .046 / + .017</b>	<b>+ .050 / + .096</b>		<b>+ .000 / + .046</b>		<b>- .113 / - .067</b>		<b>- .084</b>			
230	230.046/230.017	230.050/230.096		↓		230.000/230.046		↓	229.887/229.933	↓	
240	240.046/240.017	240.050/240.096	240.000/240.046		239.887/239.933						
250	250.046/250.017	250.050/250.096	250.000/250.046		249.887/249.933						
>250	<b>m6</b>	<b>F7</b>	<b>H7</b>		<b>R7</b>	<b>- .178</b>					
<b>MM</b>	<b>+ .052 / + .020</b>	<b>+ .056 / + .108</b>	<b>+ .000 / + .052</b>		<b>- .126 / - .074</b>	<b>- .094</b>					
260	260.052/260.020	260.056/260.108	↓		260.000/260.052	↓	259.874/259.926		↓		
270	270.052/270.020	270.056/270.108			270.000/270.052		269.874/269.926				
280	280.052/280.020	280.056/280.108			280.000/280.052		279.874/279.926				
>280	<b>m6</b>	<b>F7</b>			<b>H7</b>		<b>R7</b>				<b>- .182</b>
<b>MM</b>	<b>+ .052 / + .020</b>	<b>+ .056 / + .108</b>			<b>+ .000 / + .052</b>		<b>- .130 / - .078</b>				<b>- .098</b>
290	290.052/290.020	290.056/290.108		↓	290.000/290.052		↓	289.870/289.922		↓	
300	300.052/300.020	300.056/300.108			300.000/300.052			299.870/299.922			
310	310.052/310.020	310.056/310.108			310.000/310.052			309.870/309.922			
315	315.052/315.020	315.056/310.108			315.000/315.052			314.870/314.922			
>315	<b>m6</b>	<b>F7</b>			<b>H7</b>			<b>R7</b>			<b>- .201</b>
<b>MM</b>	<b>+ .057 / + .021</b>	<b>+ .062 / + .119</b>	<b>+ .000 / + .057</b>		<b>- .144 / - .087</b>	<b>- .108</b>					
320	320.057/320.021	320.062/320.119	↓		320.000/320.057	↓		319.856/319.913	↓		
330	330.057/330.021	330.062/330.119			330.000/330.057			329.856/329.913			
340	340.057/340.021	340.062/340.119			340.000/340.057			339.856/339.913			
350	350.057/350.021	350.062/350.119			350.000/350.057			349.856/349.913			
355	355.057/355.021	355.062/355.119		355.000/355.057	354.856/354.913						
>355	<b>m6</b>	<b>F7</b>		<b>H7</b>	<b>R8</b>		<b>- .260</b>				
<b>MM</b>	<b>+ .057 / + .021</b>	<b>+ .062 / + .119</b>		<b>+ .000 / + .057</b>	<b>- .203 / - .114</b>		<b>- .135</b>				
360	360.057/360.021	360.062/360.119		↓	360.000/360.057		↓	359.797/359.886		↓	
370	370.057/370.021	370.062/370.119			370.000/370.057			369.797/369.886			
380	380.057/380.021	380.062/380.119			380.000/380.057			379.797/379.886			
390	390.057/390.021	390.062/390.119	390.000/390.057		389.797/389.886						
400	400.057/400.021	400.062/400.119	400.000/400.057		399.797/399.886						
>400	<b>m6</b>	<b>F7</b>	<b>H7</b>		<b>R8</b>	<b>- .286</b>					
<b>MM</b>	<b>+ .063 / + .023</b>	<b>+ .068 / + .131</b>	<b>+ .000 / + .063</b>		<b>- .223 / - .126</b>	<b>- .149</b>					
410	410.063/410.023	410.068/410.131	↓		410.000/410.063	↓		409.777/409.874	↓		
420	420.063/420.023	420.068/420.131			420.000/420.063			419.777/419.874			
430	430.063/430.023	430.068/430.131			430.000/430.063			429.777/429.874			
440	440.063/440.023	440.068/440.131		440.000/440.063	439.777/439.874						
450	450.063/450.023	450.068/450.131		450.000/450.063	449.777/449.874						
>450	<b>m6</b>	<b>F7</b>		<b>H7</b>	<b>R8</b>		<b>- .292</b>				
<b>MM</b>	<b>+ .063 / + .023</b>	<b>+ .068 / + .131</b>		<b>+ .000 / + .063</b>	<b>- .229 / - .132</b>		<b>- .155</b>				
460	460.063/460.023	460.068/460.131		↓	460.000/460.063		↓	459.771/459.868		↓	
470	470.063/470.023	470.068/470.131			470.000/470.063			469.771/469.868			
480	480.063/480.023	480.068/480.131			480.000/480.063			479.771/479.868			
490	490.063/490.023	490.068/490.131	490.000/490.063		489.771/489.868						
500	500.063/500.023	500.068/500.131	500.000/500.063		499.771/499.868						

① Dimensions shaded are in millimeters.  
 ② Positive values are clearance, negative values are interference. For reference only.





866-REXNORD/866-739-6673 (Within the US)  
414-643-2366 (Outside the US)  
[www.rexnord.com](http://www.rexnord.com)

## Why Choose Rexnord?

When it comes to providing highly engineered products that improve productivity and efficiency for industrial applications worldwide, Rexnord is the most reliable in the industry. Commitment to customer satisfaction and superior value extend across every business function.

### Delivering Lowest Total Cost of Ownership

The highest quality products are designed to help prevent equipment downtime and increase productivity and dependable operation.

### Valuable Expertise

An extensive product offering is accompanied by global sales specialists, customer service and maintenance support teams, available anytime.

### Solutions to Enhance Ease of Doing Business

Commitment to operational excellence ensures the right products at the right place at the right time.

# REXNORD

## Rexnord Corporation

Rexnord is a growth-oriented, multi-platform industrial company with leading market shares and highly trusted brands that serve a diverse array of global end markets.

## Process and Motion Control

The Rexnord Process & Motion Control platform designs, manufactures, markets and services specified, highly engineered mechanical components used within complex systems where our customers' reliability requirements and the cost of failure or downtime are extremely high.

## Water Management

The Rexnord Water Management platform designs, procures, manufactures and markets products that provide and enhance water quality, safety, flow control and conservation.