

SNR Linear Motion : Ball screws



A global manufacturer of bearings.



For almost a century, SNR has designed, developed and manufactured bearings to meet the most demanding of applications. In April 2008, SNR and the Japanese Group NTN joined forces.

As one of the 3 largest companies in the manufacture of bearings, our group offers its customers added value in terms of service, quality and products.

The NTN-SNR Group is distinguished by its global presence and by its company-wide quality assurance system.

We have been active in linear ball rail systems since 1985 and our complete range, based on innovative, high-quality products, has developed significantly.

Today, we can offer a solution for a vast range of applications that need linear motion systems.

This catalogue aims to help you discover our new standard range of ball screw products in rolled and ground versions.

The large range of nuts, options for custom machining and our extensive technical knowledge enable us to design and propose custom-made solutions for our customers.

Ball rail systems find applications in a diverse range of industries such as machine tools for metal, wood, plastic, specialist machinery, aeronautics, automated assembly lines and semi-conductor industries.

Our technical department draws on many years of experience in all these areas and is available to help you develop solutions suited to your needs.

With that in mind, this technical documentation was designed as a basis for dialogue. Our technical and sales engineers will provide you with any technical information you may require.

Contents

Page

Ball screws overview	2
Standard programme. Rolled. Tolerance class 7.	2
Special programme whirled or ground	3
Standard programme Ball screws	4
Rolled models (tolerance class 7) for the compact DIN Nut (Type SC/DC)	4
Rolled models (tolerance class 7) for nut (type SK, CI, SU/DU, SE)	5
Standard programme Ball nut	6
Type SK single miniature flange nut for rolled screws	6
Type CI single cylindrical nut for rolled screws	7
Type SC single compact flange nut to DIN 69051, for rolled screws	8
Type DC double compact flange nut to DIN 69051, for rolled screws	9
Type SU single flange nut to DIN 69051, for rolled screws	10
Type DU double flange nut to DIN 69051, for rolled screws	11
Type SE single wide pitch nut for rolled screws	12
Type SH single threaded nose nuts for rolled screws	13
Bearing units	14
Fixed bearing unit PBUF with angular contact ball bearing	14-15
Floating bearing unit PBUL with grooved ball bearing DIN 625	16-17
Fixed bearing unit BK	18
Fixed bearing unit EK	19
Floating bearing unit BF	20
Standard spindle ends	21
F, Machining for fixed bearings	21
S, Machining for supported housing	22
Travel variation and travel deviation	23
Running and bearing test according to ISO 3408-3	25
Functional tests according to ISO 3408-3	28
Axial clearance and preloading	30
Critical speed of ball screws	31
Permissible axial load for the screw (buckling)	32
Calculation basis	33
Mounting the nut on the screw	34
Operating and maintenance information for the ball screws	35-37
Typ designation code	38-39
Ball screw coding	39
Your enquiry form	40
Other Catalogue Documentation	41

Ball Screw Overview

Standard programme. Rolled. Tolerance class 7.

Materials: Spindles Ck55
 Nuts 15CrMo5
 Balls 100Cr6

Sealing system for ball screws: Smooth running sealing

Size	Nut type															
	SK		CI		SC		DC		SU		DU		SE		SH	
	R	L	R	L	R	L	R	L	R	L	R	L	R	L	R	L
0601	●															
0801	●															
0802	●															
082.5	●															●
01002	●															●
01004	●															●
01202	●															
01204									●							●
01205					●											●
01210																
01402	●															
01604			●						●		●					●
01605			●	●	●		●		●	●	●	●				●
01610					●		●		●		●					
01616					●								●			
01620					●											
02004			●						●		●					
02005			●	●	●		●		●	●	●	●				●
02010					●		●									
02020					●								●			
02504			●						●		●					
02505			●	●	●		●		●	●	●	●				●
02510			●		●		●		●		●					
02525					●								●			
03204			●						●		●					
03205			●	●	●		●		●	●	●	●				
03210			●	●	●		●		●	●	●	●				
03220					●		●									
03232					●								●			
04005			●	●	●		●		●	●	●	●				
04010			●	●	●		●		●	●	●	●				
04020					●		●									
04040					●								●			
05005					●		●									
05010			●		●		●		●	●	●	●				
05020					●		●									
05050					●								●			
06310			●		○		●		●		●					
06320					○		●		●		●					
08010			●		○		○		●		●					
08020					●				●		●					

- R: Rolled, right-hand thread
- L: Rolled, left-hand thread
- Available from stock
- Available from ex stock
- Not a standard programme, request through project

Special programme whirled or polished

Whirled:	Tolerance classes T7, T5
Ground:	Tolerance classes T5, T3, T1
Models:	Metric and inch
Diameter:	From 6 mm to 125 mm
Pitch:	From 1 mm to 50 mm
Nut variants:	With flange according to DIN/ISO Cylindrical With thread socket Miniature Special models
Preload:	Max 5% of dynamic load rating (single nut) Max 10% of dynamic load rating (double nut)
Materials:	Spindles Cf53, X90CrMoV5 (rust-proof e.g. for application in medical technology) Nuts 16MnCr5, rust-free models are possible Balls 100Cr6, X45Cr13 (rust-resistant) ceramic balls

Wiper: PTFE wipers, brush wipers, felt wipers etc.

ATC coating e.g. for use in corrosive media, food industry.

The ATC coating consists of more than 98% pure chromium. It is an extremely hard, crack-free, dome-shaped, precise, very thin and highly pure chromium coating.

Standard programme

Ball screws

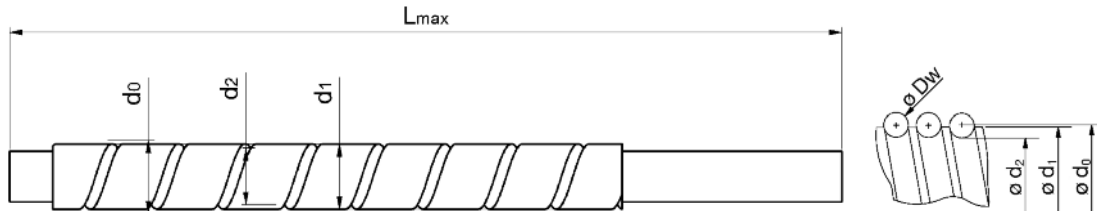

- d Reference diameter [mm]
- d_0 Nominal diameter [mm]
- d_1 Outside diameter [mm]
- d_2 Diameter at the thread root [mm]
- P Pitch [mm]
- L_{max} Maximum length of screw [mm]

Rolled models (tolerance class 7) for the compact DIN Nut (Type SC/DC)

References	Dimensions [mm]						Moment of inertia	Mass
	d	d_0	P	d_1	d_2	L_{max}	kg • m ² /m	kg/m
BSH01205	12	12,30	5	12	9,80	1000	7,64x10 ⁻⁶	0,61
BSH01210	12	12,30	10	12	9,80	1000	1,42x10 ⁻⁵	0,83
BSH01605	16	15,67	5	15	12,89	3000	3,17x10 ⁻⁵	1,24
BSH01610	16	15,67	10	15	12,89	3000	3,54x10 ⁻⁵	1,32
BSH01616	16	15,67	16	15	12,89	2900	3,45x10 ⁻⁵	1,30
BSH01620	16	15,67	20	15	12,89	3000	3,54x10 ⁻⁵	1,32
BSH02005	20	21,08	5	20	17,90	3000	1,04x10 ⁻⁴	2,25
BSH02010	20	21,08	10	20	17,90	3000	1,14x10 ⁻⁴	2,36
BSH02020	20	20,75	20	20	17,60	3000	1,12x10 ⁻⁴	2,34
BSH02505	25	26,08	5	25	22,90	5800	2,62x10 ⁻⁴	3,59
BSH02510	25	26,08	10	25	22,90	5800	2,82x10 ⁻⁴	3,72
BSH02525	25	26,08	25	25	22,90	5500	2,62x10 ⁻⁴	3,59
BSH03205	32	33,08	5	32	29,90	6000	7,24x10 ⁻⁴	5,97
BSH03210	32	32,35	10	31	28,38	5600	6,54x10 ⁻⁴	5,97
BSH03220	32	32,35	20	31	28,38	5500	6,54x10 ⁻⁴	5,67
BSH03232	32	32,35	32	31	28,38	5000	6,76x10 ⁻⁴	5,77
BSH04005	40	41,08	5	40	37,90	6000	1,80x10 ⁻³	9,44
BSH04010	40	39,52	10	38	33,17	6000	1,29x10 ⁻³	7,93
BSH04020	40	39,52	20	38	33,17	6000	1,29x10 ⁻³	7,93
BSH04040	40	39,52	40	38	33,17	5000	1,45x10 ⁻³	8,42
BSH05005	50	51,09	5	50	47,92	6000	4,49x10 ⁻³	14,88
BSH05010	50	50,16	10	48	43,81	6000	3,54x10 ⁻³	13,18
BSH05020	50	50,16	20	48	43,81	6000	3,54x10 ⁻³	13,18
BSH05050	50	50,16	50	48	43,81	6000	3,87x10 ⁻³	13,80
BSH06310	63	63,16	10	61	56,81	7000	9,22x10 ⁻³	21,64
BSH06320	63	63,43	20	61	56,29	7000	9,51x10 ⁻³	21,29
BSH08010	80	79,16	10	77	72,80	7000	2,47x10 ⁻²	34,92
BSH08020	80	80,24	20	77	70,71	7000	2,45x10 ⁻²	34,72

Rolled models (tolerance class 7) for nut (type SK, CI, SU/DU, SE)

References	Dimensions [mm]						Moment of inertia	Mass
	d	d ₀	P	d ₁	d ₂	L _{max}	kg • m ² /m	kg/m
BSH00601	6	6,27	1	6	5,47	900	0,83x10 ⁻⁷	0,20
BSH00801	8	8,20	1	8	7,40	1200	2,67x10 ⁻⁶	0,36
BSH00802	8	8,41	2	8	7,21	1000	2,71x10 ⁻⁶	0,36
BSH00802.5	8	8,41	2,5	10	7,21	1000	2,80x10 ⁻⁶	0,37
BSH01002	10	10,41	2	10	9,21	1200	5,11x10 ⁻⁶	0,58
BSH01004	10	10,68	4	12	8,68	1200	6,53x10 ⁻⁶	0,57
BSH01202	12	12,41	2	12	11,21	1200	1,07x10 ⁻⁵	0,62
BSH01204	12	12,30	4	12	9,80	1000	1,51x10 ⁻⁵	0,86
BSH01205	12	12,30	5	12	9,80	1000	7,64x10 ⁻⁶	0,78
BSH01402	14	14,41	2	14	13,21	1200	2,01x10 ⁻⁵	0,85
BSH01604	16	16,82	4	16	14,40	3000	4,35x10 ⁻⁵	1,46
BSH01605	16	17,08	5	16	13,90	3000	4,45x10 ⁻⁵	1,41
BSH01610	16	17,08	10	16	12,90	3000	4,36x10 ⁻⁵	1,46
BSH01616	16	15,67	16	16	12,90	3000	3,34x10 ⁻⁵	1,27
BSH02004	20	20,82	4	20	18,40	3000	1,09x10 ⁻⁴	2,32
BSH02005	20	21,08	5	20	17,90	3000	1,12x10 ⁻⁴	2,35
BSH02010	20	21,08	10	20	17,90	3000	1,18x10 ⁻⁴	2,41
BSH02020	20	20,76	20	20	17,60	3000	1,00x10 ⁻⁴	2,21
BSH02504	25	25,82	4	25	23,40	6000	2,73x10 ⁻⁴	3,65
BSH02505	25	26,08	5	25	22,90	5800	2,62x10 ⁻⁴	3,59
BSH02510	25	27,15	10	25	20,80	5800	2,94x10 ⁻⁴	3,81
BSH02525	25	26,09	25	25	22,90	5000	2,60x10 ⁻⁴	3,64
BSH03204	32	32,82	4	32	30,40	6000	7,48x10 ⁻⁴	6,08
BSH03205	32	33,08	5	32	29,90	6000	7,25x10 ⁻⁴	5,98
BSH03210	32	34,15	10	32	27,80	5900	7,69x10 ⁻⁴	6,16
BSH03220	32	33,35	20	32	29,38	6000	7,76x10 ⁻⁴	6,37
BSH03232	32	32,35	32	32	28,40	5000	6,89x10 ⁻⁴	5,81
BSH04005	40	41,08	5	40	37,90	6000	1,81x10 ⁻³	9,44
BSH04010	40	42,15	10	40	35,80	6000	1,66x10 ⁻³	9,02
BSH04040	40	39,52	40	38	33,20	5500	1,43x10 ⁻³	8,29
BSH05010	50	52,15	10	50	45,80	6000	4,19x10 ⁻³	14,35
BSH05020	50	53,58	20	50	44,05	6000	4,45x10 ⁻³	14,82
BSH05050	50	52,25	50	50	44,31	6000	4,33x10 ⁻³	14,59
BSH06310	63	65,15	10	63	58,80	7000	1,09x10 ⁻²	23,12
BSH06320	63	66,24	20	63	56,72	7000	1,15x10 ⁻²	23,83
BSH08010	80	82,15	10	80	75,80	7000	2,89x10 ⁻²	37,76
BSH08020	80	83,25	20	80	73,72	7000	2,87x10 ⁻²	37,56

Standard programme

Ball nut

Type SK single miniature flange nut for rolled screws

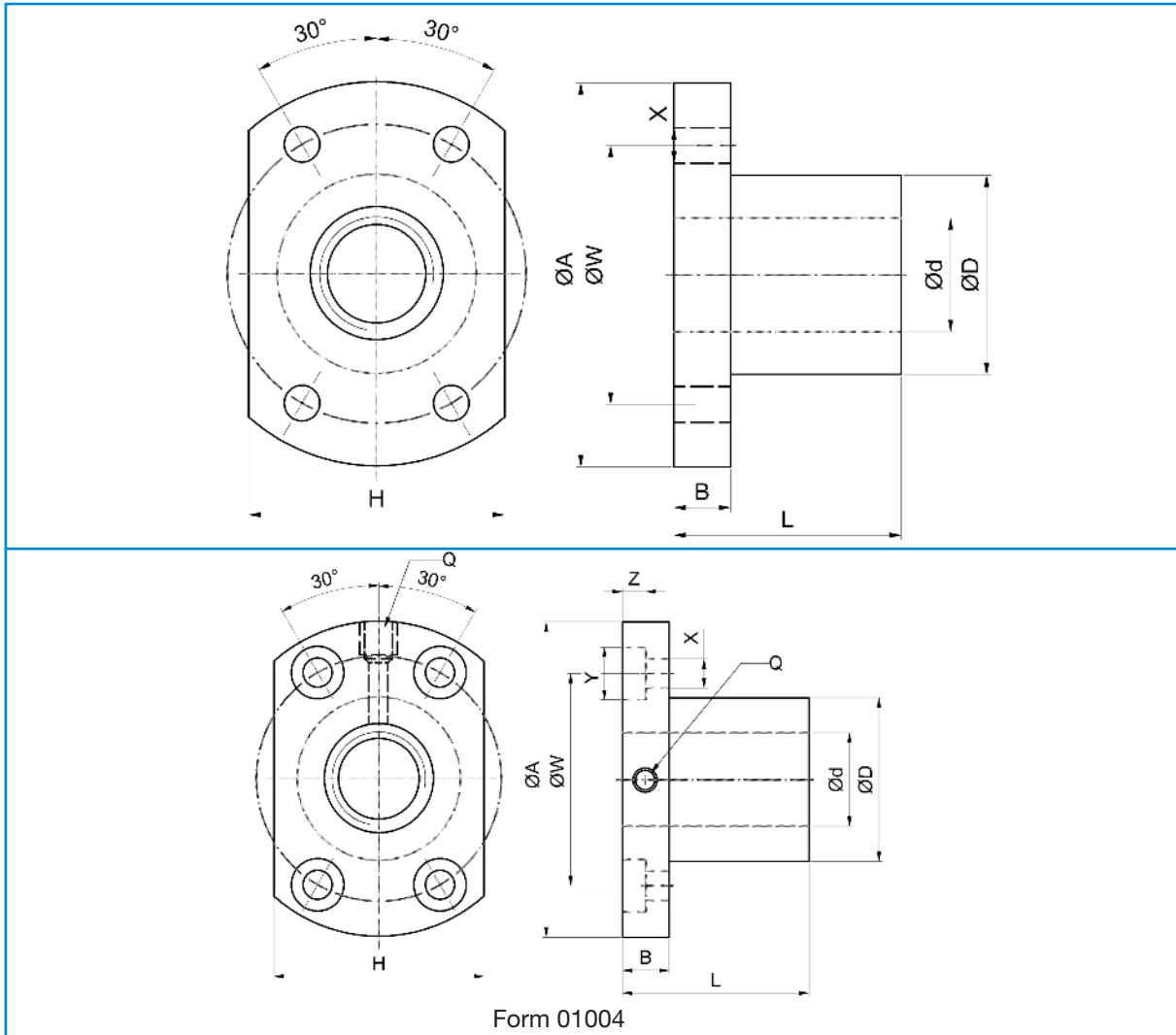

Size	Thread	Dimensions [mm]														Load rating [kN]		Stiffness K, [N/µm]
		d	p	Ball-ø	D g6	A	B	L	W	H ±0,10	X	Y	Z	Q	Number*	dyn. C _a	stat. C _{a0}	
00601	R	6	1	0,80	12	24	3,5	15	18	16	3,4	-	-	-	3	1,09	2,19	88
00801	R	8	1	0,80	14	27	4	16	21	18	3,4	-	-	-	4	1,58	3,95	137
00802	R		2	1,20	14	27	4	16	21	18	3,4	-	-	-	3	2,17	4,49	127
0082.5	R		2,5	1,20	16	29	4	26	23	20	3,4	-	-	-	3	2,17	4,49	127
01002	R	10	2	1,20	18	35	5	28	27	22	4,5	-	-	-	3	2,38	5,58	147
01004	R		4	2,00	26	46	10	34	36	28	4,5	8	4,5	M6	3	4,59	8,88	167
01202	R	12	2	1,20	20	37	5	28	29	24	4,5	-	-	-	4	3,28	8,88	216
01402	R	14	2	1,20	21	40	6	23	31	26	5,5	-	-	-	4	3,48	10,3	235

Ball nut sizes shown in bold are available ex stock.

* Number of circuits

P-Pitch

Type CI single cylindrical nut for rolled screws

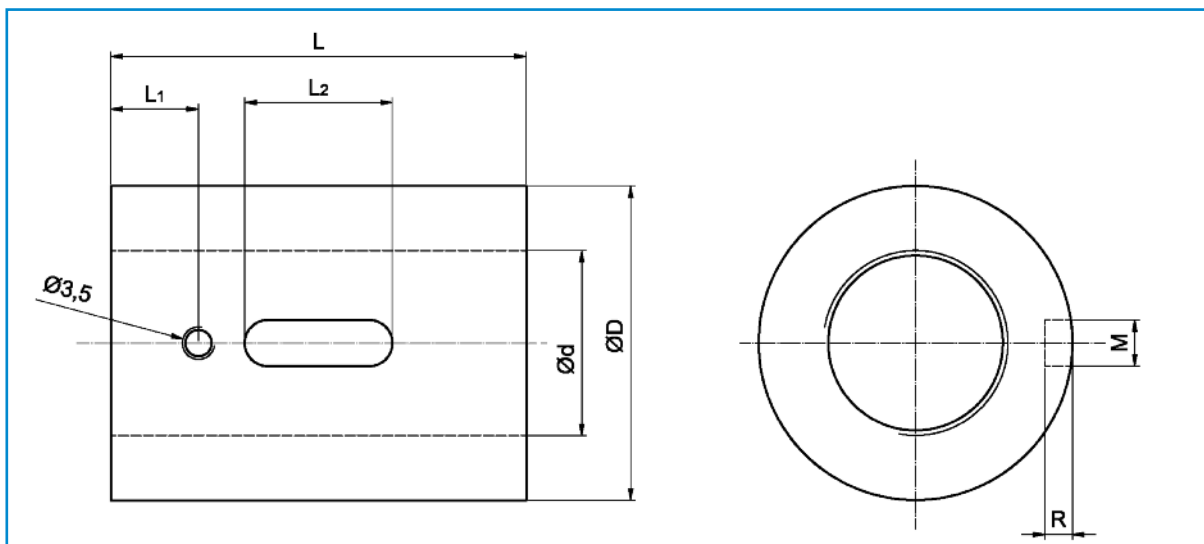

Size	Thread	Dimensions [mm]										Number*	Load rating [kN]		Stiffness K, [N/µm]
		d	p	Ball-ø	D g6	L	L1	L2	M	R	dyn. Ca		stat. Ca0		
01604-4	R	16	4	2,381	30	40	9	15	3	±0,05	1,5	4	9,54	23,59	314
01605-4	R/L		5	3,175	30	45	9	20	5	±0,05	3,0	4	13,53	29,93	324
02004-4	R	20	4	2,381	34	40	9	15	3	±0,05	1,5	4	10,15	29,29	363
02005-4	R/L		5	3,175	34	45	9	20	5	±0,05	3,0	4	15,20	38,00	382
02504-4	R	25	4	2,381	40	40	9	15	3	±0,05	1,5	4	11,58	37,22	422
02505-4	R/L		5	3,175	40	45	9	20	5	±0,05	3,0	4	16,91	48,09	441
02510-4	R		10	4,762	46	85	13	30	5	±0,05	3,0	4	28,96	71,54	500
03204-4	R	32	4	2,381	46	40	9	15	3	±0,05	1,5	4	12,71	47,44	481
03205-4	R/L		5	3,175	46	45	9	20	5	±0,05	3,0	4	18,85	62,21	510
03210-4	R		10	6,350	54	85	13	30	5	±0,05	3,0	4	47,12	119,72	608
04005-4	R/L	40	5	3,175	56	45	9	20	5	±0,05	3,0	4	20,69	78,34	579
04010-4	R/L		10	6,350	62	85	13	30	5	±0,05	3,0	4	52,95	152,00	706
05010-4	R	50	10	6,350	72	85	13	30	5	±0,05	3,0	4	58,88	192,35	814
06310-4	R	63	10	6,350	85	85	13	30	6	±0,05	3,5	4	65,89	248,58	932
08010-4	R	80	10	6,350	105	85	13	30	8	±0,10	4,5	4	72,04	313,36	1069

Ball nut sizes shown in bold are available ex stock.

* Number of circuits

P-Pitch

Standard programme

Ball nut

Type SC single compact flange nut to DIN 69051, for rolled screws

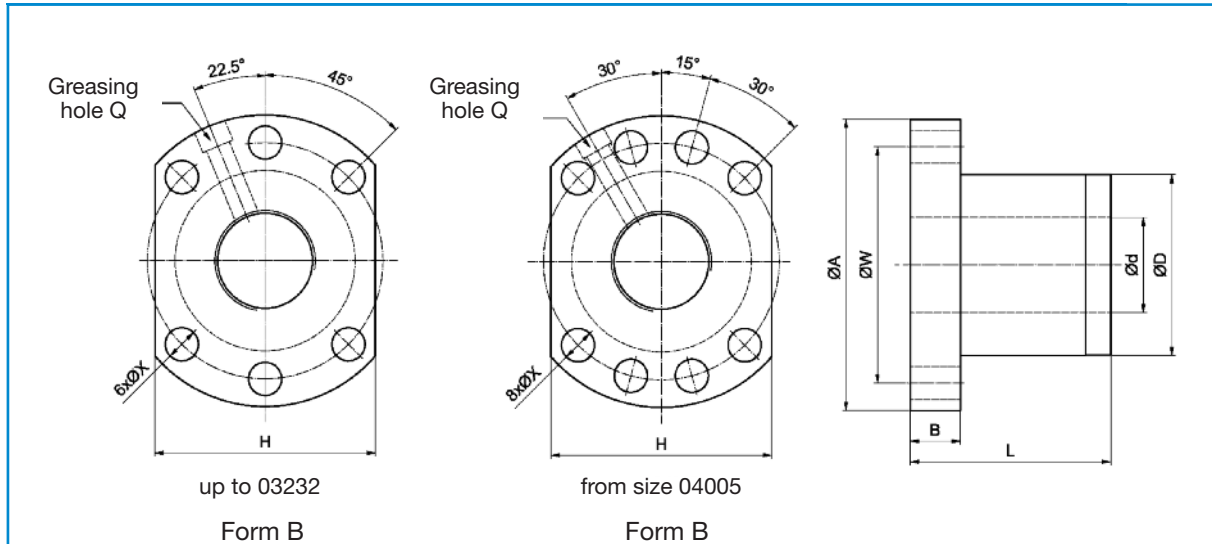

Size	Thread	Dimensions [mm]											Number*	Load rating [kN]		Stiffness K [N/µm]	
		d	p	Ball-ø	D g6	A	B	L	W	H	X	Q		dyn. C _a	stat. C _{a0}		
01205-2,8	R	12	5	2,500	24	40	10	31	32	30	±0,10	4,5		2,8x1	6,49	12,90	186
01605-3,8	R	15	5	2,778	28	48	10	38	38	40	±0,15	5,5	M6x1P	3,8x1	10,90	24,59	294
01610-2,8	R		10	2,778	28	48	10	47	38	40	±0,15	5,5	M6x1P	2,8x1	8,23	17,86	226
01616-1,8	R	16	16	2,778	28	48	10	45	38	40	±0,15	5,5	M6x1P	1,8x1	5,42	11,15	137
01616-2,8	R		16	2,778	28	48	10	61	38	40	±0,15	5,5	M6x1P	2,8x1	7,92	17,34	216
01620-1,8	R	20	2,778	28	48	10	57	38	40	±0,15	5,5	M6x1P	1,8x1	5,43	11,47	137	
02005-3,8	R	20	5	3,175	36	58	10	40	47	44	±0,15	6,6	M6x1P	3,8x1	15,55	36,10	363
02010-3,8	R		10	3,175	36	58	10	60	47	44	±0,15	6,6	M6x1P	3,8x1	14,87	37,59	392
02020-1,8	R	20	20	3,175	36	58	10	57	47	44	±0,15	6,6	M6x1P	1,8x1	7,96	17,24	186
02020-2,8	R		20	3,175	36	58	10	77	47	44	±0,15	6,6	M6x1P	2,8x1	10,96	26,81	284
02505-3,8	R	25	5	3,175	40	62	10	40	51	48	±0,15	6,6	M6x1P	3,8x1	16,18	45,68	422
02510-3,8	R		10	3,175	40	62	12	62	51	48	±0,15	6,6	M6x1P	3,8x1	16,06	45,43	441
02525-1,8	R	25	25	3,175	40	62	12	70	51	48	±0,15	6,6	M6x1P	1,8x1	8,26	21,57	2156
02525-2,8	R		25	3,175	40	62	12	95	51	48	±0,15	6,6	M6x1P	2,8x1	12,08	33,55	333
03205-3,8	R	31	5	3,175	50	80	12	42	65	62	±0,15	9,0	M6x1P	3,8x1	18,03	59,10	500
03210-3,8	R		10	3,969	50	80	13	62	65	62	±0,15	9,0	M6x1P	3,8x1	24,13	71,15	539
03220-2,8	R	31	20	3,969	50	80	12	80	65	62	±0,15	9,0	M6x1P	2,8x1	18,70	53,76	422
03232-1,8	R		32	3,969	50	80	13	84	65	62	±0,15	9,0	M6x1P	1,8x1	12,33	33,60	265
03232-2,8	R	32	3,969	50	80	13	116	65	62	±0,15	9,0	M6x1P	2,8x1	18,02	52,30	412	
04005-3,8	R	38	5	3,175	63	93	15	45	78	70	±0,15	9,0	M8x1P	3,8x1	19,80	74,42	588
04010-3,8	R		10	6,350	63	93	14	63	78	70	±0,15	9,0	M8x1P	3,8x1	49,37	136,73	657
04020-2,8	R	38	20	6,350	63	93	14	82	78	70	±0,15	9,0	M8x1P	2,8x1	38,82	105,08	533
04040-1,8	R		40	6,350	63	93	15	105	78	70	±0,15	9,0	M8x1P	1,8x1	25,35	65,19	333
04040-2,8	R	40	6,350	63	93	15	145	78	70	±0,15	9,0	M8x1P	2,8x1	37,07	101,41	510	
05005-3,8	R	48	5	3,175	75	110	15	45	93	85	±0,15	11,0	M8x1P	3,8x1	21,65	93,58	667
05010-3,8	R		10	6,350	75	110	18	68	93	85	±0,15	11,0	M8x1P	3,8x1	55,29	175,07	775
05020-3,8	R	50	6,350	75	110	18	108	93	85	±0,15	11,0	M8x1P	3,8x1	56,38	181,27	853	

Ball nut sizes shown in bold are available ex stock.

* Number of circuits

P-Pitch

Type DC double compact flange nut to DIN 69051, for rolled screws

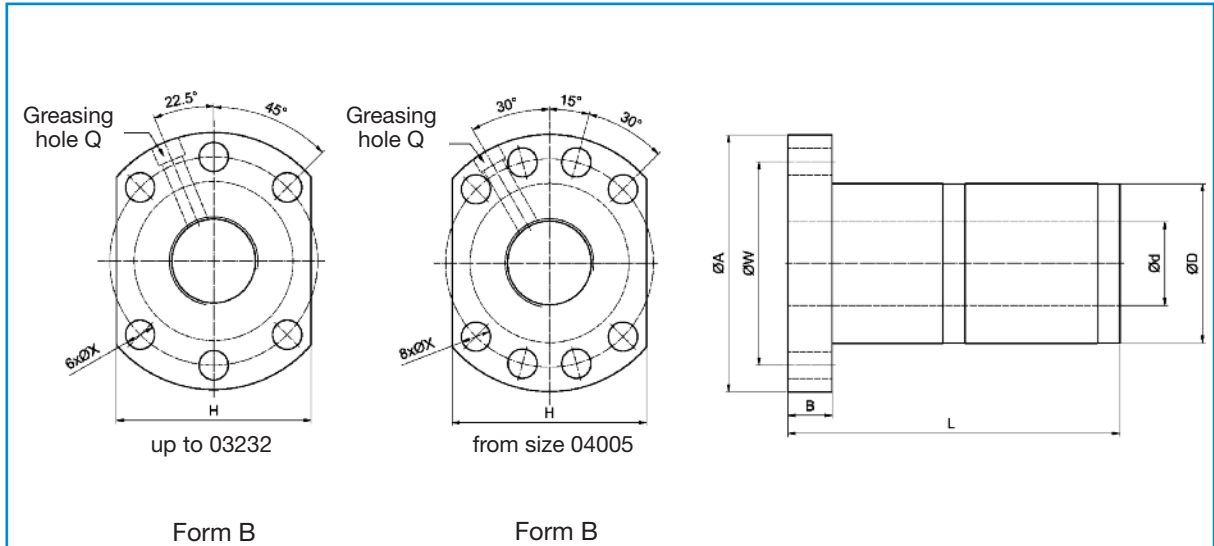

Size	Thread	Dimensions [mm]											Number*	Load rating [kN]		Stiffness K [N/µm]	
		d	p	Ball-ø	D g6	A	B	L	W	H	X	Q		dyn. C _a	stat. C _{a0}		
01605-3,8	R	15	5	2,778	28	48	10	73	38	40	±0,15	5,5	M6x1P	3,8x1	10,90	24,59	402
01610-2,8	R		10	2,778	28	48	10	97	38	40	±0,15	5,5	M6x1P	2,8x1	8,23	17,86	304
02005-3,8	R	20	5	3,175	36	58	10	75	47	44	±0,15	6,6	M6x1P	3,8x1	15,55	36,10	490
02010-3,8	R		10	3,175	36	58	10	120	47	44	±0,15	6,6	M6x1P	3,8x1	14,87	37,59	520
02505-3,8	R	25	5	3,175	40	62	10	75	51	48	±0,15	6,6	M6x1P	3,8x1	16,18	45,68	579
02510-3,8	R		10	3,175	40	62	12	122	51	48	±0,15	6,6	M6x1P	3,8x1	16,06	45,43	598
03205-3,8	R	31	5	3,175	50	80	12	82	65	62	±0,15	9,0	M6x1P	3,8x1	18,03	59,10	696
03210-3,8	R		10	3,969	50	80	13	122	65	62	±0,15	9,0	M6x1P	3,8x1	24,13	71,15	735
03220-2,8	R	20	3,969	50	80	12	160	65	62	±0,15	9,0	M6x1P	2,8x1	18,70	53,76	569	
04005-3,8	R	38	5	3,175	63	93	15	85	78	70	±0,15	9,0	M8x1P	3,8x1	19,80	74,42	814
04010-3,8	R		10	6,350	63	93	14	123	78	70	±0,15	9,0	M8x1P	3,8x1	49,37	136,73	892
04020-2,8	R	20	6,350	63	93	14	162	78	70	±0,15	9,0	M8x1P	2,8x1	38,82	105,08	716	
05005-3,8	R	48	5	3,175	75	110	15	85	93	85	±0,15	11,0	M8x1P	3,8x1	21,65	93,58	941
05010-3,8	R		10	6,350	75	110	18	138	93	85	±0,15	11,0	M8x1P	3,8x1	55,29	175,07	1069
05020-3,8	R	20	6,350	75	110	18	218	93	85	±0,15	11,0	M8x1P	3,8x1	56,38	181,27	1138	

Ball nut sizes shown in bold are available ex stock.

* Number of circuits

P-Pitch

Standard programme

Ball nut

Type SU single flange nut to DIN 69051, for rolled screws

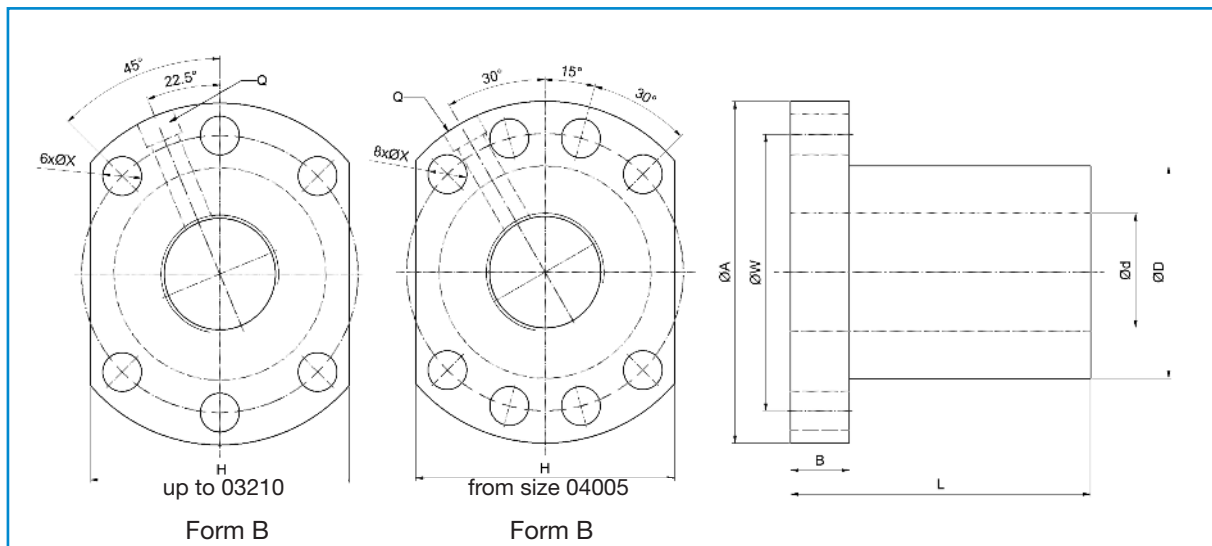

Size	Thread	Dimensions [mm]											Number*	Load rating [kN]		Stiffness K [N/µm]	
		d	p	Ball-ø	D g6	A	B	L	W	H	X	Q		dyn. C _a	stat. C _{a0}		
01604-4	R	16	4	2,381	28	48	10	40	38	40	±0,15	5,5	M6	4	9,54	23,59	314
01605-4	R/L		5	3,175	28	48	10	50	38	40	±0,15	5,5	M6	4	13,53	29,93	314
01610-3	R		10	3,175	28	48	10	57	38	40	±0,15	5,5	M6	3	10,82	23,55	255
02004-4	R	20	4	2,381	36	58	10	42	47	44	±0,15	6,6	M6	4	10,45	29,29	372
02005-4	R/L		5	3,175	36	58	10	51	47	44	±0,15	6,6	M6	4	15,21	38,00	382
02504-4	R	25	4	2,381	40	62	10	42	51	48	±0,15	6,6	M6	4	11,58	37,22	421
02505-4	R/L		5	3,175	40	62	10	51	51	48	±0,15	6,6	M6	4	16,91	48,09	441
02510-4	R		10	4,762	40	62	12	85	51	48	±0,15	6,6	M6	4	28,96	71,54	490
03204-4	R	32	4	2,381	50	80	12	44	65	62	±0,15	9,0	M6	4	12,71	47,44	500
03205-4	R/L		5	3,175	50	80	12	52	65	62	±0,15	9,0	M6	4	18,85	62,21	529
03210-4	R/L		10	6,350	50	80	12	90	65	62	±0,15	9,0	M6	4	47,12	119,72	598
04005-4	R/L	40	5	3,175	63	93	14	55	78	70	±0,15	9,0	M8	4	20,69	78,34	617
04010-4	R/L		10	6,350	63	93	14	93	78	70	±0,15	9,0	M8	4	52,95	152,00	715
05010-4	R/L	50	10	6,350	75	110	16	93	93	85	±0,15	11,0	M8	4	58,88	192,35	833
06310-4	R	63	10	6,350	90	125	18	98	108	95	±0,15	11,0	M8	4	65,89	248,68	970
06320-4	R		20	9,525	95	135	20	149	115	100	±0,15	13,5	M8	4	112,23	359,44	1098
08010-4	R	80	10	6,350	105	145	20	98	125	110	±0,15	13,5	M8	4	72,04	313,36	1068
08020-4	R		20	9,525	125	165	25	154	145	130	±0,20	13,5	M8	4	126,61	468,24	1352

Ball nut sizes shown in bold are available ex stock.

* Number of circuits

P-Pitch

Type DU double flange nut to DIN 69051, for rolled screws

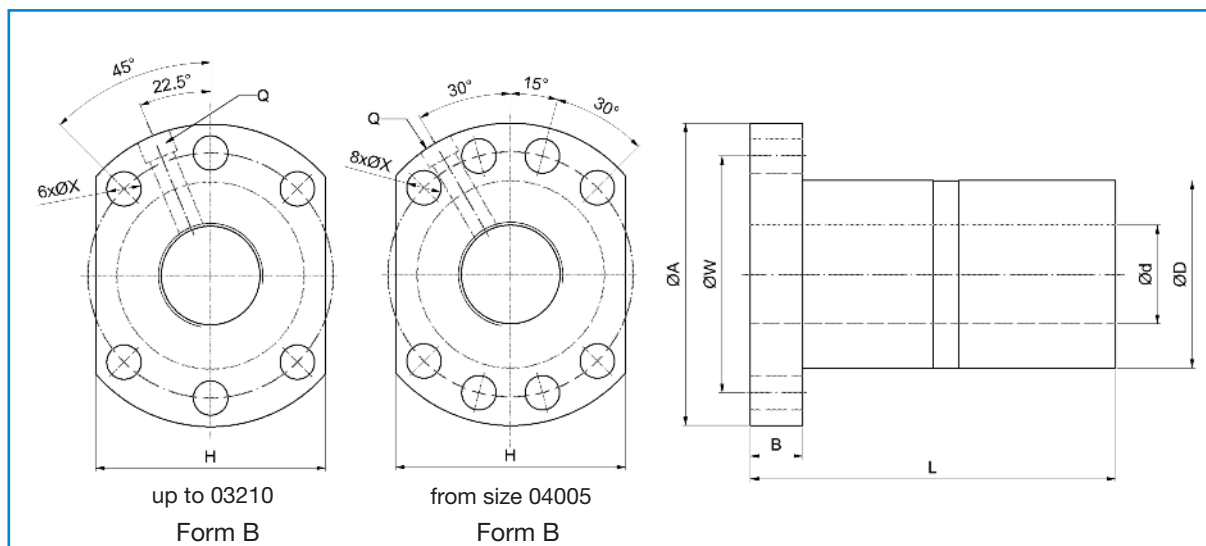

Size	Thread	Dimensions [mm]											Number*	Load rating [kN]		Stiffness K [N/µm]	
		d	p	Ball-ø	D g6	A	B	L	W	H	X	Q		dyn. C _a	stat. C _{a0}		
01604-4	R	16	4	2,381	28	48	10	80	38	40	±0,15	5,5	M6	4	9,54	23,59	421
01605-4	R/L		5	3,175	28	48	10	100	38	40	±0,15	5,5	M6	4	13,53	29,93	431
01610-3	R		10	3,175	28	48	10	118	38	40	±0,15	5,5	M6	3	10,82	23,55	343
02004-4	R	20	4	2,381	36	58	10	80	47	44	±0,15	6,6	M6	4	10,45	29,29	500
02005-4	R/L		5	3,175	36	58	10	101	47	44	±0,15	6,6	M6	4	15,21	38,00	519
02504-4	R	25	4	2,381	40	62	10	80	51	48	±0,15	6,6	M6	4	11,58	37,22	588
02505-4	R/L		5	3,175	40	62	10	101	51	48	±0,15	6,6	M6	4	16,91	48,09	608
02510-4	R		10	4,762	40	62	12	145	51	48	±0,15	6,6	M6	4	28,96	71,54	657
03204-4	R	32	4	2,381	50	80	12	80	65	62	±0,15	9,0	M6	4	12,71	47,44	696
03205-4	R/L		5	3,175	50	80	12	102	65	62	±0,15	9,0	M6	4	18,85	62,21	725
03210-4	R/L		10	6,350	50	80	12	162	65	62	±0,15	9,0	M6	4	47,12	119,72	804
04005-4	R/L	40	5	3,175	63	93	14	105	78	70	±0,15	9,0	M8	4	20,69	78,34	853
04010-4	R/L		10	6,350	63	93	14	165	78	70	±0,15	9,0	M8	4	52,95	152,00	970
05010-4	R/L	50	10	6,350	75	110	16	171	93	85	±0,15	11,0	M8	4	58,88	192,35	1147
06310-4	R	63	10	6,350	90	125	18	182	108	95	±0,15	11,0	M8	4	65,89	248,68	1362
06320-4	R		20	9,525	95	135	20	290	115	100	±0,15	13,5	M8	4	112,23	359,44	1490
08010-4	R	80	10	6,350	105	145	20	182	125	110	±0,15	13,5	M8	4	72,04	313,36	1529
08020-4	R		20	9,525	125	165	25	295	145	130	±0,20	13,5	M8	4	126,61	468,24	1833

Ball nut sizes shown in bold are available ex stock.

* Number of circuits

P-Pitch

Standard programme

Ball nut

Type SE single wide pitch nut for rolled screws

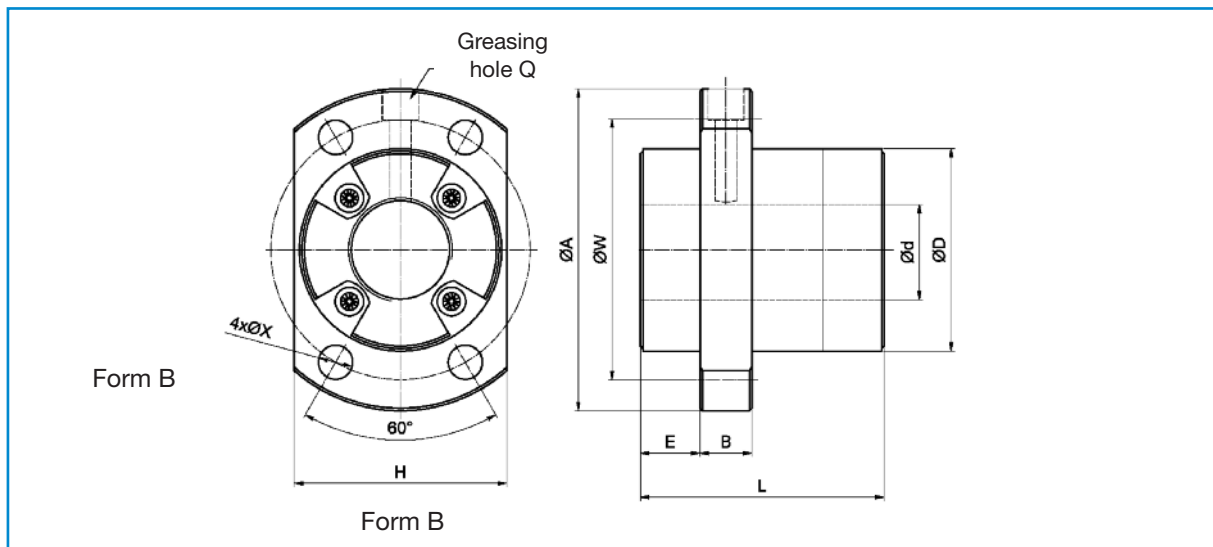

Size	Thread	Dimensions [mm]													Num-ber*	Load rating [kN]		Stiffness K [N/µm]
		d	p	Ball-Ø	D g6	A	E	B	L	W	H	X	Q	dyn. C _a		stat. C _{a0}		
01616-3	R	16	16	2,778	32	53	10,1	10	38	42	34	±0,15	4,5	M6	1,7x2	10,01	23,62	284
01616-6	R			2,778	32	53	10,1	10	38	42	34	±0,15	4,5	M6	1,7x4	18,18	47,25	559
02020-3	R	20	20	3,175	39	62	12	10	47	50	41	±0,15	5,5	M6	1,7x2	12,95	32,56	343
02020-6	R			3,175	39	62	12	10	47	50	41	±0,15	5,5	M6	1,7x4	23,51	65,12	657
02525-3	R	25	25	3,969	47	74	14	12	57	60	49	±0,15	6,6	M6	1,7x2	19,36	50,88	421
02525-6	R			3,969	47	74	14	12	57	60	49	±0,15	6,6	M6	1,7x4	35,14	101,76	813
03232-3	R	32	32	4,762	58	92	17	12	71	74	60	±0,15	9,0	M6	1,7x2	28,21	80,48	529
03232-6	R			4,762	58	92	17	12	71	74	60	±0,15	9,0	M6	1,7x4	51,93	160,96	1039
04040-3	R	40	40	6,350	73	114	19,5	15	89	93	75	±0,15	11,0	M6	1,7x2	45,11	130,24	647
04040-6	R			6,350	73	114	19,5	15	89	93	75	±0,15	11,0	M6	1,7x4	81,87	260,48	1254
05050-3	R	50	50	7,938	90	135	21,5	20	107	112	92	±0,15	14,0	M6	1,7x2	63,86	190,54	784
05050-6	R			7,938	90	135	21,5	20	107	112	92	±0,15	14,0	M6	1,7x4	115,92	381,08	1519

Ball nut sizes shown in bold are available ex stock.

* Number of circuits
Ground on request

Type SH single threaded nose nuts for rolled screws

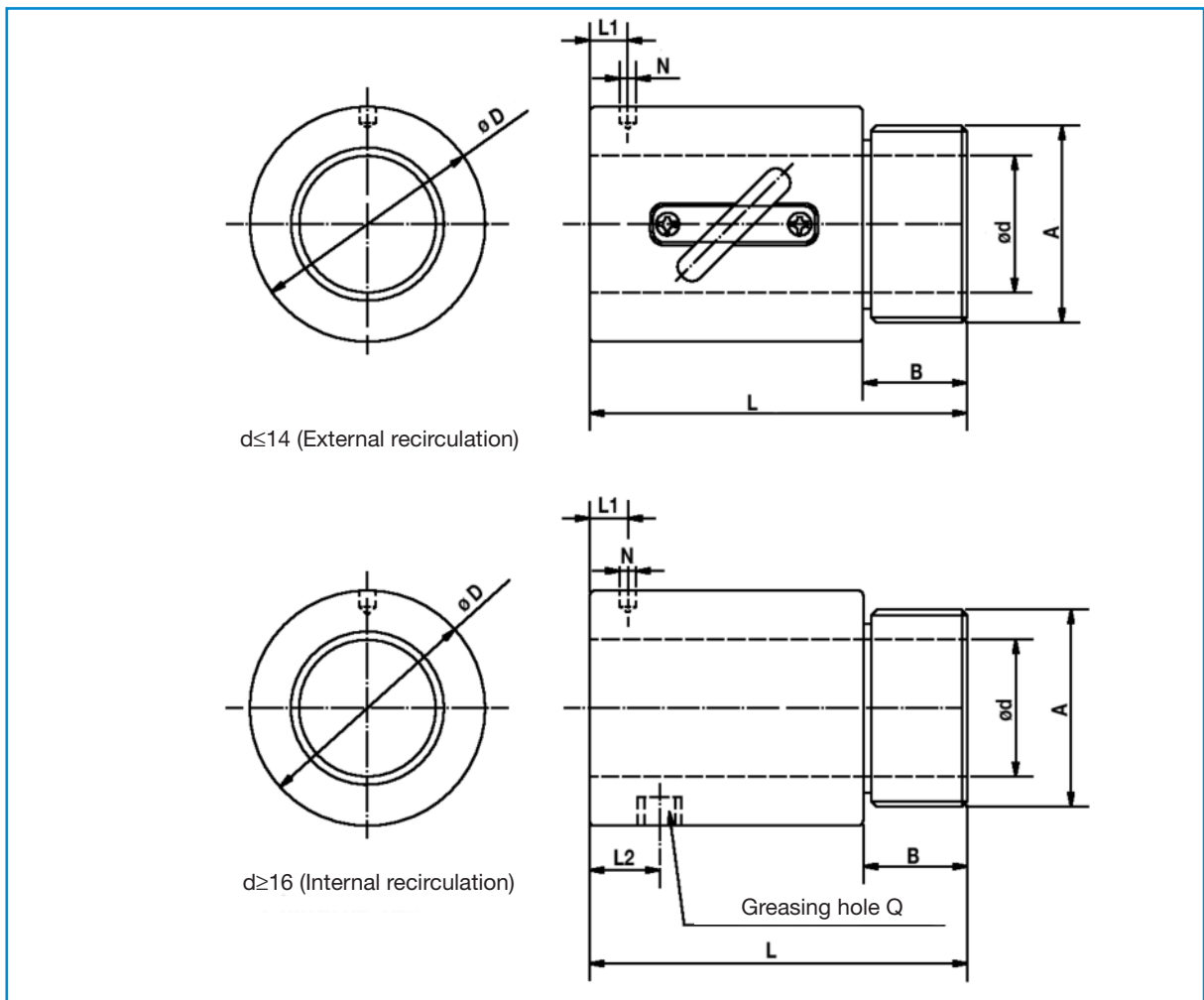

Size	Thread	Dimensions [mm]											Number*	Load rating [kN]		Stiffness K [N/μm]	
		d	p	Ball-ø	D	A	B	L	L1	N	L2	Q		dyn. Ca	stat. Ca0		
0082.5	R	8	2,5	1,2	17,5	M15x1P	7,5	23,5	±0,15	10	3	-	-	2,5x1	1,85	3,73	108
01002	R	10	2	1,2	19,5	M17x1P	7,5	22	±0,15	3	3,2	-	-	3,5x1	2,72	6,51	167
01004	R		4	2	25	M20x1P	10	34	±0,15	3	3	-	-	2,5x1	3,92	7,39	137
01204	R	12	4	2,5	25,5	M20x1P	10	34	±0,15	13	3	-	-	3,5x1	7,88	16,16	226
01205	R		5	2,5	25,5	M20x1P	10	39	±0,15	16,25	3	-	-	3,5x1	7,85	16,11	235
01404	R	14	4	2,381	32,1	M25x1,5P	10	35	±0,15	13	3	-	-	3,5x1	7,88	17,67	255
01604	R	16	4	2,381	29	M22x1,5P	8	32	±0,15	4	3,2	-	-	3x1	7,44	17,68	235
01605	R		5	3,175	32,5	M26x1,5P	12	42	±0,15	19,25	3	-	-	3x1	10,56	22,43	245
02005	R	20	5	3,175	38	M35x1,5P	15	45	±0,15	20,3	3	-	-	3x1	11,87	28,48	294
02505	R	25	5	3,175	43	M40x1,5P	19	69	±0,15	32,11	3	8	M6	4x1	16,89	48,06	363

Ball nut sizes shown in bold are available ex stock.

* Number of circuits

Ground on request

Bearing units

Fixed bearing unit PBUF with angular contact ball bearing

The fixed bearing units consist of:

- Pillow block housing made of steel with stop edges on both sides, direct drive adaption and lubrication option
- Double row angular contact ball bearing with a contact angle of 58°
- Slotted nut with radial clamping
- Thread ring

Suitable for standard spindle ends type F3, F4 (see page 21)

Unit	Spindle Nominal Diameter	Pitch	Ød	D	B	Bearing	C [N]	C0 [N]	Slotted nut	Ma [Nm]	MG [Nm]	H1	H2 ±0,02	H3	H4	H5
PBUF10	16	4 / 5	10	34	20	BSLN 1034 -2RS	13100	15700	PRS 10x1	6	2	58	32	22	4	15
PBUF12	16	10/ 16	12	42	25	BSLN 1242 -2RS	18300	21300	PRS 12x1	8	2	64	34	22	5	15
	20	4 / 5														
PBUF15	20	10 / 20	15	45	25	BSLN 1545 -2RS	19600	24700	PRS 15x1	10	3	64	34	22	2	15
PBUF17	25	5/ 10/ 25	17	47	25	BSLN 1747 -2RS	20800	27800	PRS 17x1	15	3	72	39	27	5	18
PBUF20	32	10	20	52	28	BSLN 2052 -2RS	24500	34000	PRS 20x1	18	5	77	42	27	2	18
PBUF25	32	4 / 5 / 20/ 32	25	57	28	BSLN 2557 -2RS	27000	41900	PRS 25x1	25	5	77	42	27	3	18
PBUF30	40	5 / 10 / 40	30	62	28	BSLN 3062 -2RS	29300	49750	PRS 30x1,5	32	5	90	50	32	2	21
PBUF35	50	10 / 20	35	72	34	BSLN 3572 -2RS	37900	64200	PRS 35x1,5	40	5	105	58	38	5	22
PBUF40	50	50	40	90	46	BSLN 4090 -2RS	99767	124600	PRS 40x1,5	55	5	138	73	50	11	22
PBUF50	63	10/ 20	50	110	54	BSLN 50110 -2RS	105600	179700	PRS 50x1,5	85	5	165	93	50	8	36
	80	10/ 20														

Ma – Tightening torque slotted nut
MG – Tightening torque threaded pin

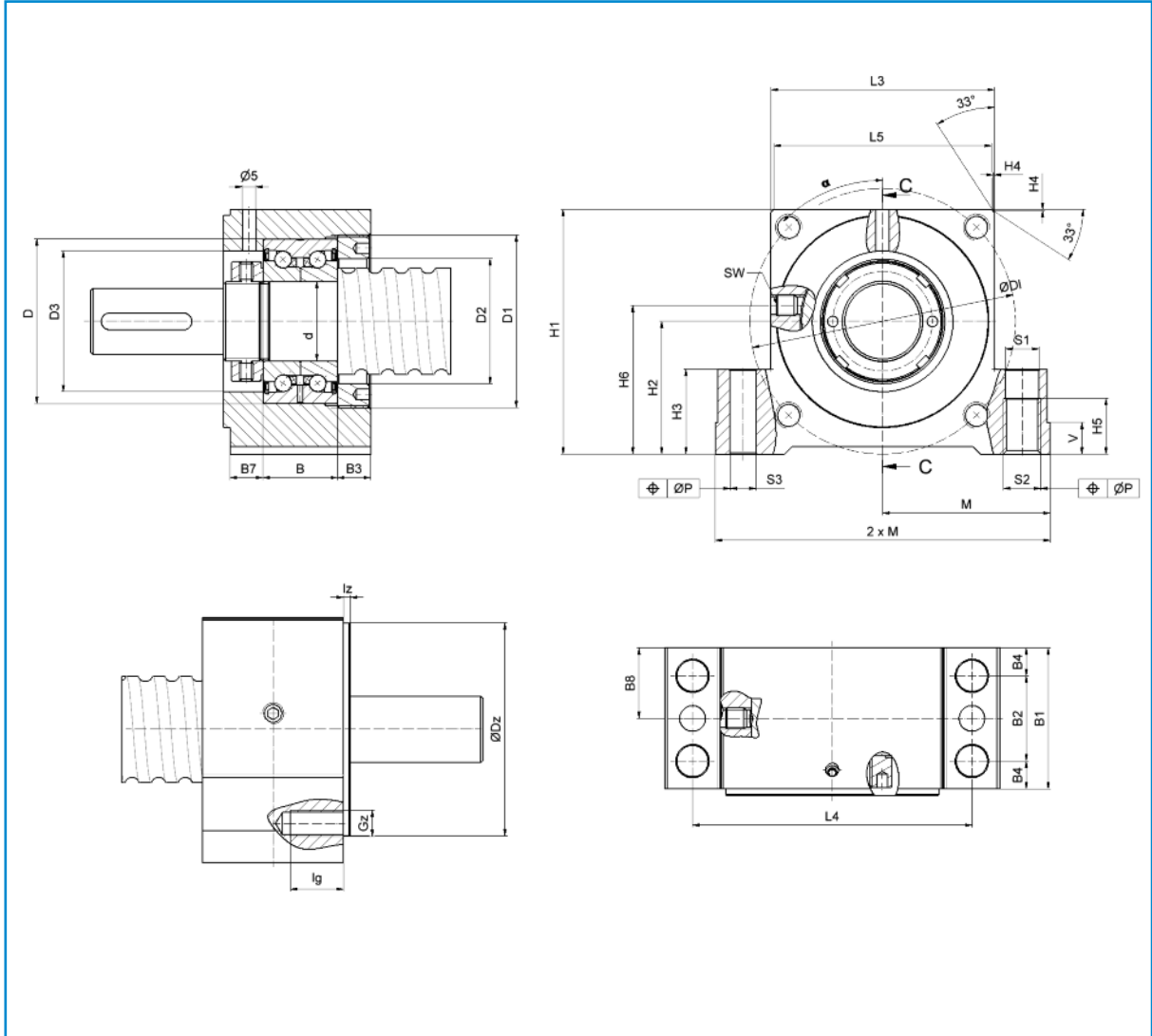

H6	L3	L4	L5	B1	B2	B3	B4	B5	B7	B8	M js7	V	S1 H12	S2	S3	D1	D3	DZ	lz	DI	Gz	lg	alpha [°]	SW	P	Weight [kg]	Weight only housing [kg]
37	52	68	32	37	23	8,5	7	18,5	8,5	18,5	43	8	8,4	M10	7,7	M36x1,5	27	38	1,5	51	M4	10	45	4	0,15	0,9	0,7
40	60	77	41,1	42	25	8,5	8,5	21	8,5	21	47	8	8,4	M10	7,7	M45x1,5	32	42	1,5	56	M4	10	18,8	4	0,15	1,2	1,0
40	60	77	50	42	25	8,5	8,5	21	8,5	21	47	8	8,4	M10	7,7	M47x1,5	34	55	1,5	70	M6	12	45	4	0,15	1,1	0,9
45	66	88	41	46	29	10,5	8,5	23	10,5	23	54	10	10,5	M12	9,7	M50x1,5	36	55	2	70	M6	12	45	4	0,2	1,7	1,4
48	70	92	60	49	29	10,5	10	24,5	10,5	24,5	56	10	10,5	M12	9,7	M55x1,5	42	55	2	70	M6	10	45	4	0,2	2	1,5
48	70	92	56	49	29	10,5	10	24,5	10,5	24,5	56	10	10,5	M12	9,7	M60x1,5	49	65	2	75	M8	20	45	4	0,2	2	1,3
56	80	105	76	53	32	12,5	10,5	26,5	12,5	26,5	63	12	12,6	M14	9,7	M65x1,5	53	65	2	75	M8	20	45	4	0,2	2,8	2,2
63	92	118	82	70	43	20,5	13,5	35	15,5	32,5	72	12	12,5	M14	9,7	M78x2	60	80	2,5	100	M10	20	45	4	0,2	4,7	4,0
78	130	160	108	85	58	22,5	13,5	42,5	16,5	39,5	95	16	12,5	M14	9,7	M95x2	72	110	3	130	M10	17	45	4	0,2	10,5	9,2
98	145	175	129	98	58	25,5	20	49	18,5	45,5	102,5	16	17,3	M20	11,7	M115x2	90	140	3	160	M12	20	45	4	0,2	15,7	12,8

Floating bearing unit PBUL with deep grooved ball bearing DIN 625

The floating bearing unit consists of:

- Pillow block housing made of steel
- Deep grooved ball bearing DIN 62...-2RS
- Retaining ring DIN 471
- Cover

Suitable for standard spindle ends type S2 (see page 22)

Unit	Spindle Nominal Diameter	Pitch	Bearing	Ød	ØD	B	C [N]	C0 [N]	Safety ring DIN471	H1	H2 ±0,02
PBUL10	16	4 / 5	6200 -2RS	10	30	9	6000	2650	10x1	58	32
PBUL12	16	10/ 16	6201 -2RS	12	32	10	6800	3050	12x1	64	34
	20	4 / 5									
PBUL15	20	10 / 20	6202 -2RS	15	35	11	7700	3750	15x1	64	34
PBUL17	25	5/ 10/ 25	6203 -2RS	17	40	12	9500	4750	17x1	72	39
PBUL20	32	10	6204 -2RS	20	47	14	12800	6600	20x1,2	77	42
PBUL25	32	4 / 5 / 20/ 32	6205 -2RS	25	52	15	14000	7900	25x1,2	77	42
PBUL30	40	5 / 10 / 40	6206 -2RS	30	62	16	19500	11300	30x1,5	90	50
PBUL35	50	10 / 20	6207 -2RS	35	72	17	25500	15300	35x1,5	105	58
PBUL40	50	50	6308 -2RS	40	90	23	40500	23900	40x1,75	138	73
PBUL50	63	10/ 20	6310 -2RS	50	110	27	62000	38000	50x2	165	93
	80	10/ 20									

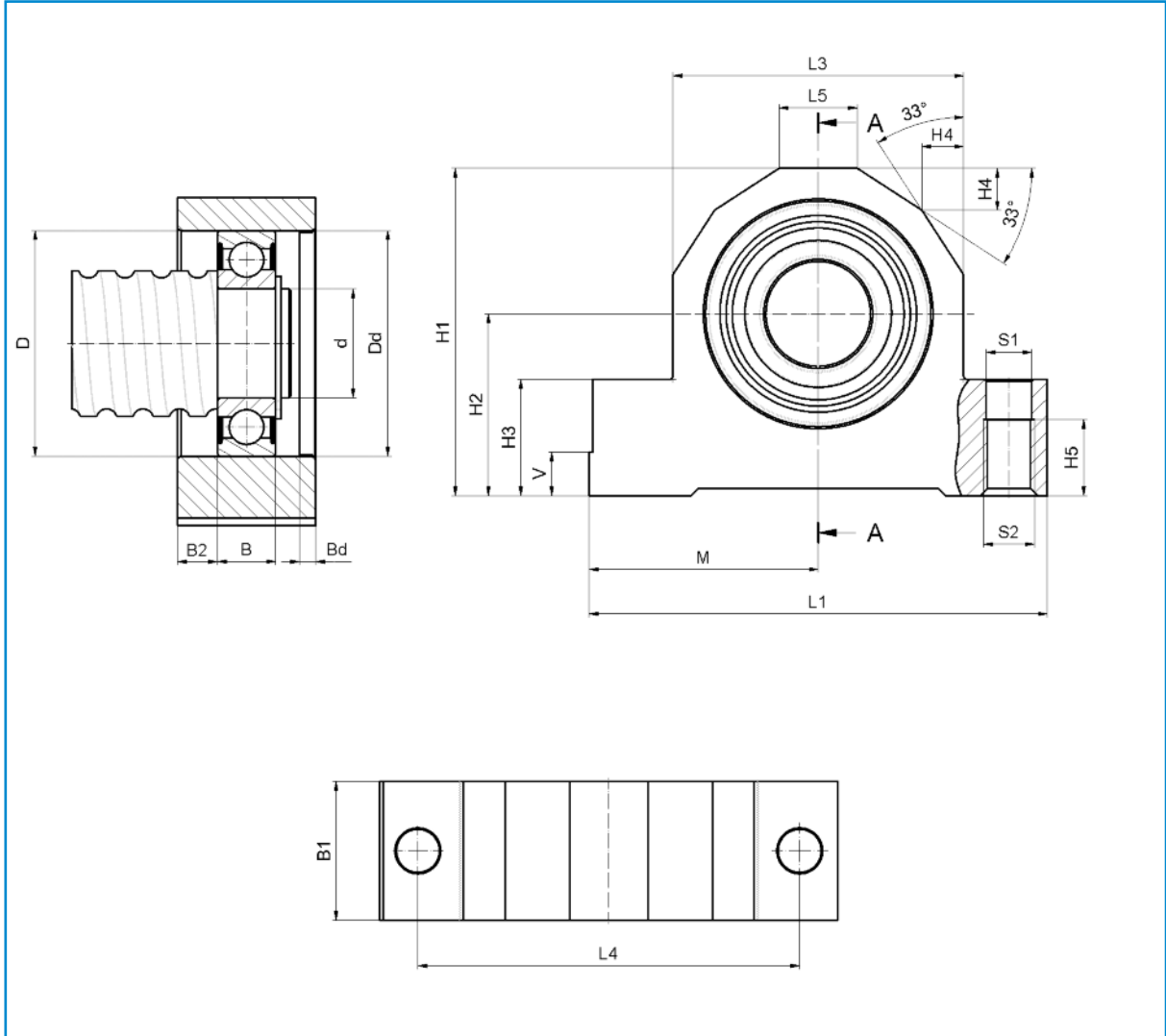

H3	H4	H5	L1	L3	L4	L5	B1	B2	M js7	S1 H12	S2	V	ØDd J6	Bd	Weight [kg]	Weight only housing [kg]
22	5	15	86	52	68	32	24	7,5	43	8,4	M10	8	30	3,8	0,6	0,5
22	5	15	94	60	77	38	26	8	47	8,4	M10	8	32	3,8	0,8	0,7
22	5	15	94	60	77	38	26	7,5	47	8,4	M10	8	35	3,8	0,7	0,7
27	5	18	108	66	88	41	28	8	54	10,5	M12	10	40	3,7	1	0,9
27	6	18	112	70	92	40	34	10	56	10,5	M12	10	47	4,8	1,3	1,2
27	6	18	112	70	92	40	34	9,5	56	10,5	M12	10	52	4,8	1,2	1,1
32	5,5	21	126	80	105	52	38	11	63	12,6	M14	12	62	4,5	1,7	1,5
38	7,5	22	144	92	118	54	41	12	72	12,5	M14	12	72	5	2,7	2,2
50	11	22	190	130	160	76	46	13	95	12,5	M14	16	90	5	5,5	4,8
50	11	36	205	145	175	91	50	14	102,5	17,3	M20	16	110	6	7,4	6,2

Fixed bearing unit BK

The fixed bearing unit consists of:

- Pillow block housing made of black oxidized steel
- Two angular contact ball bearings
- Two seals with contact rings
- Slotted nut

Suitable for standard spindle ends type F1, F2 (see page 21)

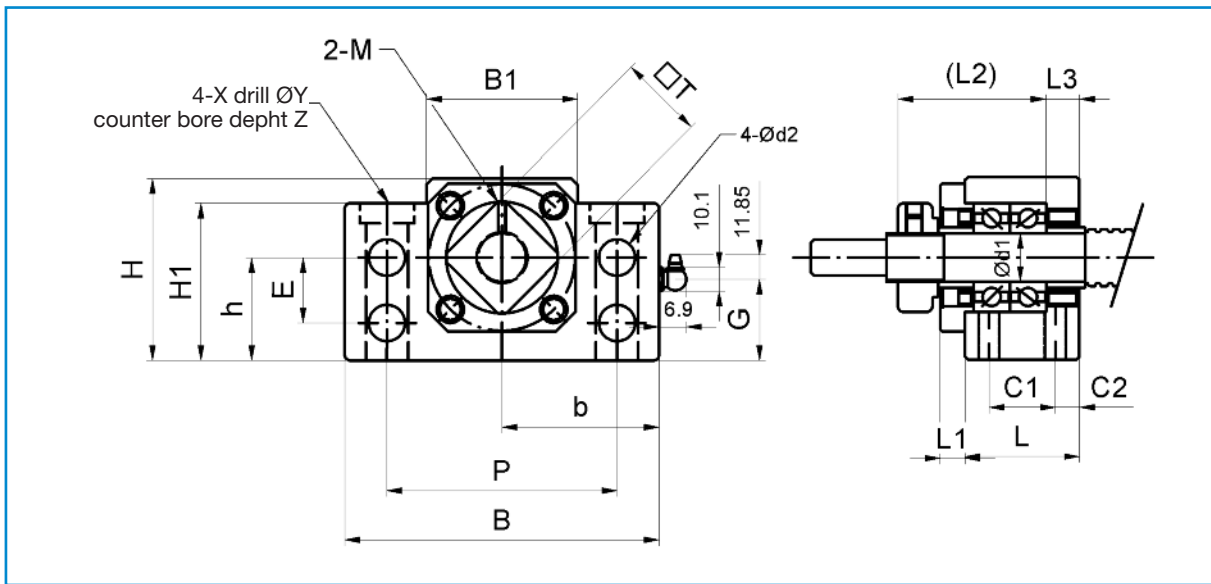

Unit	Spindle Nominal Diameter	Pitch	d1	L	L1	L2	L3	B	H	b _{±0,02}	h _{±0,02}	B1	H1	E	P	C1	C2	d2	MX	M	T	G	Q	Weight [kg]
BK10	16	4 / 5	10	25	5	29	5	60	39	30	22	34	32,5	15	46	13	6	5,5	6	M3	16	15	M6	0,4
	14	2																						
BK12	16	10/ 16	12	25	5	29	5	60	43	30	25	34	32,5	18	46	13	6	5,5	6	M4	19	18	M6	0,45
	20	4 / 5																						
BK15	20	10 / 20	15	27	6	32	6	70	48	35	28	40	38	18	54	15	6	5,5	6	M4	22	18	M6	0,69
BK17	25	5/ 10/ 25	17	35	9	44	7	86	64	43	39	50	55	28	68	19	8	6,6	8	M4	24	30	M6	1,3
BK20	32	10	20	35	8	43	8	88	60	44	34	52	50	22	70	19	8	6,6	8	M4	30	24	M6	1,3
BK25	32	4 / 5 / 20/ 32	25	42	12	54	9	106	80	53	48	64	70	33	85	22	10	9	10	M5	35	37	M6	2,4
BK30	40	5 / 10 / 40	30	45	14	61	9	128	89	64	51	76	78	33	102	23	11	11	10	M6	40	37	M6	3,4
BK35	50	10/ 20	35	50	14	67	12	140	96	70	52	88	79	35	114	26	12	11	12	M8	50	37	M6	4,4
BK40	50	50	40	61	18	76	15	160	110	80	60	100	90	37	130	33	14	14	16	M8	50	43	M6	6,8

Fixed bearing unit EK

The fixed bearing unit consists of:

- Pillow block housing made of black oxidized steel
- Two angular contact ball bearings
- Two seals with contact rings
- Slotted nut

Suitable for standard spindle ends type F1, F2 (see page 21)

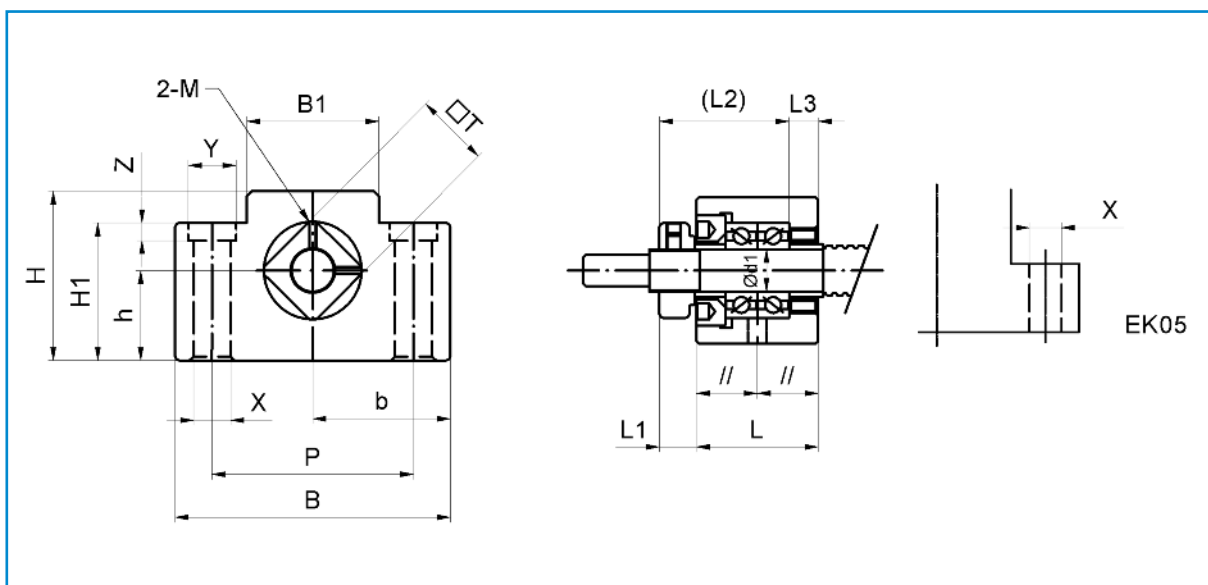

Unit	Spindle Nominal Diameter	Pitch	d1	L	L1	L2	L3	B	H	b ±0,02	h ±0,02	B1	H1	P	X	Y	Z	M	T	Weight [kg]
EK05	6	1	5	16,5	5,5	18,5	3,5	36	21	18	11	20	8	28	4,5	-	-	M3	11	0,12
EK06	8	1/ 2/ 2,5	6	20	5,5	22	3,5	42	25	21	13	18	20	30	5,5	9,5	11	M3	12	0,18
EK08	10	2/ 4	8	23	7	26	4	52	32	26	17	25	26	38	6,6	11	12	M3	14	0,27
	12	2/ 4/ 5																		

Floating bearing unit BF

The floating bearing unit consists of:

- Bearing housing made of black oxidized steel
- Deep groove ball bearing
- Retaining ring

Suitable for standard spindle ends type S1 (see page 22)

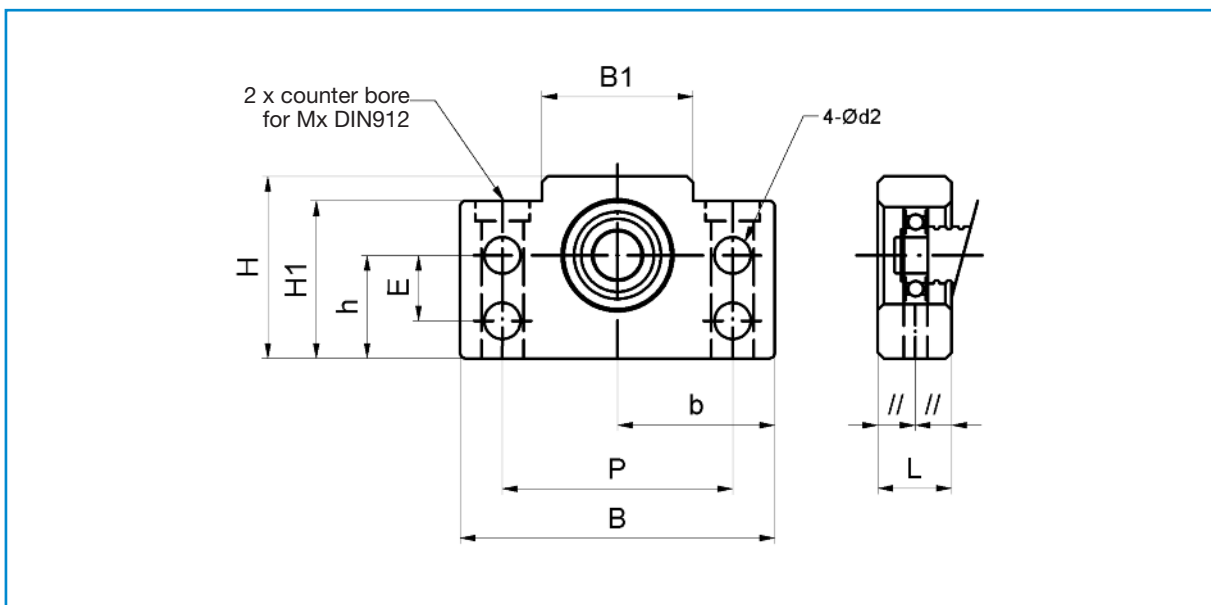

Unit	Spindle Nominal Diameter	Pitch	d1	L	B	H	b ±0,02	h ±0,02	B1	H1	E	P	d2	Mx	Bearing	Safety ring DIN471	Weight [kg]
BF10	16	4 / 5	10	20	60	39	30	22	34	32,5	15	46	5,5	6	608ZZ	8x1	0,3
	14	2															
BF12	16	10/ 16	12	20	60	43	30	25	34	32,5	18	46	5,5	6	6000ZZ	10x1	0,35
	20	4 / 5															
BF15	20	10 / 20	15	20	70	48	35	28	40	38	18	54	5,5	6	6002ZZ	15x1	0,4
BF17	25	5/ 10/ 25	17	23	86	64	43	39	50	55	28	68	6,6	8	6203ZZ	17x1	0,75
BF20	32	10	20	26	88	60	44	34	52	50	22	70	6,6	8	6004ZZ	20x1,2	0,77
BF25	32	4 / 5 / 20/ 32	25	30	106	80	53	48	64	70	33	85	9	10	6205ZZ	25x1,2	1,45
BF30	40	5 / 10 / 40	30	32	128	89	64	51	76	78	33	102	11	12	6206ZZ	30x1,5	1,95
BF35	50	10 / 20	35	32	140	96	70	52	88	79	35	114	11	12	6207ZZ	35x1,5	2,25
BF40	50	50	40	37	160	110	80	60	100	90	37	130	14	16	6208ZZ	40x1,75	3,3

I Standard spindle ends

Machining for fixed bearings

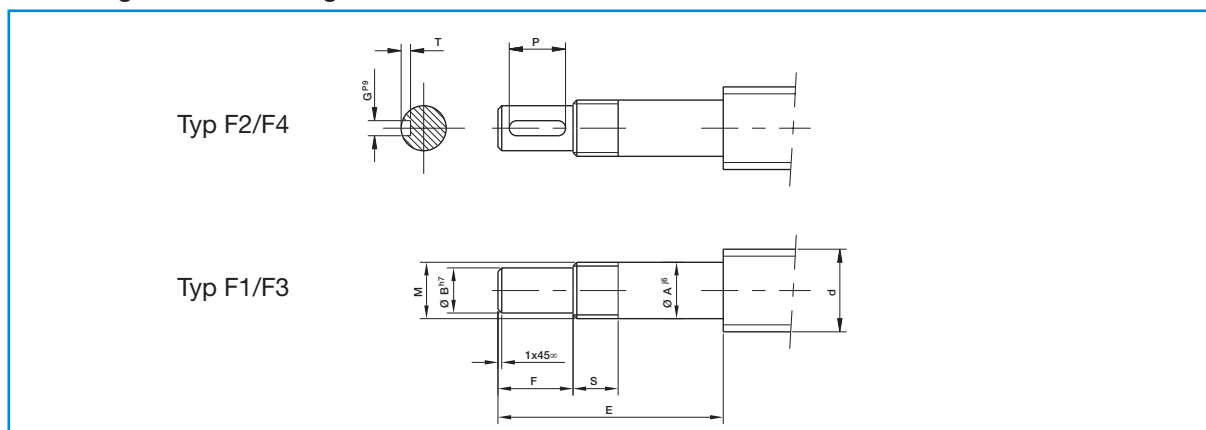

Model F1/F2

Unit	Spindle Nominal Diameter	Pitch	$\varnothing A_{j6}$	$\varnothing B_{h7}$	E	F	M	S	Typ F2 (with cotter pin)			Recommended bearing unit
									G	T	P	
5	6	1	5	4	31	6	M5x0,5	7	-	-	-	EK5
6	8	1/ 2/ 2,5	6	4	38	8	M6x0,75	8	-	-	-	EK6
8	10	2/ 4	8	6	44	9	M8x1	10	-	-	-	EK8
	12	2/ 4/ 5										
10	14	2	10	8	54	15	M10x1	16	2	1,2	11	BK10
	16	4/ 5										
12	16	10/ 16	12	10	54	15	M12x1	14	3	1,8	12	BK12
	20	4/ 5										
15	20	10/ 20	15	12	60	20	M15x1	15	4	2,5	16	BK15
17	25	5/ 10/ 25	17	15	76	23	M17x1	20	5	3	20	BK17
20	32	10	20	17	78	25	M20x1	15	5	3	21	BK20
25	32	4/ 5/ 20/ 32	25	20	95	30	M25x1,5	18	6	3,5	25	BK25
30	40	5/ 10/ 40	30	25	110	38	M30x1,5	25	8	4	32	BK30
35	50	10/ 20	35	30	128	45	M35x1,5	28	8	4	40	BK35
40	50	50	40	35	148	50	M40x1,5	35	10	5	45	BK40

Model F3/F4

Unit	Spindle Nominal Diameter	Pitch	$\varnothing A_{h6}$	$\varnothing B_{h7}$	M	E	S	F	Typ F4 (Key)			Recommended bearing unit
									G	P	T	
10	16	4/5	10	8	M10x1	50	12	20	-	-	-	PBUF10
12	16	10/16	12	10	M12x1	60	12	25	3	20	1.8	PBUF12
	20	4/5										
15	20	10/20	15	12	M15x1	65	17	25	4	20	2.5	PBUF15
17	25	5/10/25	17	15	M17x1	70	19	28	5	22	3	PBUF17
20	32	10	20	15	M20x1	75	19	30	6	25	3.5	PBUF20
25	32	4/5/20/32	25	22	M25x1,5	76	21	30	6	25	3.5	PBUF25
30	40	5/10/40	30	25	M30x1,5	86	23	38	8	32	4	PBUF30
35	50	10/20	35	30	M35x1,5	110	28	50	8	36	4	PBUF35
40	50	50	40	36	M40x1,5	132	28	60	10	40	5	PBUF40
50	63	10/20	50	40	M50x1,5	154	32	70	12	50	5	PBUF50
	80	10/20										

Machining for floating bearings

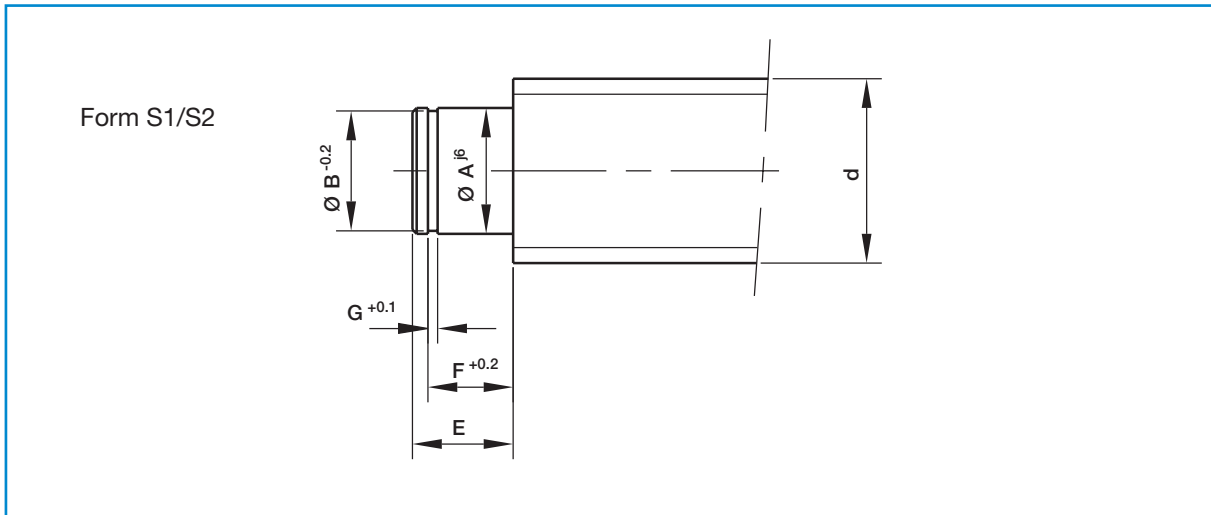

Model S1

Model	Nominal diameter of the spindle	Pitch	A	E	B	G	F	Recommended bearing unit
10	14	2	10	11	9,6	1,15	9,15	BF10
	16	4 / 5						
12	16	10/ 16	12	11	9,6	1,15	9,15	BF12
	20	4 / 5						
15	20	10 / 20	15	13	14,3	1,15	10,15	BF15
17	25	5/ 10/ 25	17	16	16,2	1,15	13,15	BF17, PBUL17
20	32	10	20	16	19	1,35	13,35	BF20
25	32	4 / 5 / 20/ 32	25	20	23,9	1,35	16,35	BF25, PBUL25
30	40	5 / 10 / 40	30	21	28,6	1,75	17,75	BF30, PBUL30
35	50	10 / 20	35	22	33	1,75	18,75	BF35
40	50	50	40	24	38	1,95	19,95	BF40

Model S2

Model	Nominal diameter of the spindle	Pitch	ØA j6	ØB		E	F	G H13	Recommended bearing unit
10	16	4 / 5	10	9,6	h10	12	10,1	1,1	PBUL10
12	16	10/ 16	12	11,5	h11	13	11,1	1,1	PBUL12
	20	4 / 5							
15	20	10 / 20	15	14,3	h11	14	12,1	1,1	PBUL15
17	25	5/ 10/ 25	S1 (use)						PBUL17
20	32	10	20	19	h11	18	15,3	1,3	PBUL20
25	32	4 / 5 / 20/ 32	S1 (use)						PBUL25
30	40	5 / 10 / 40	S1 (use)						PBUL30
35	50	10 / 20	35	33	h12	22	18,6	1,6	PBUL35
40	50	50	40	37,5	h12	28	24,85	1,85	PBUL40
50	63	10/ 20	50	47	h12	27	29,15	2,15	PBUL50
	80	10/ 20							

I Travel variation and travel deviation

The tolerance classes of the SNR ball screws are defined in accordance with ISO 3408. The tolerance classes T0-T5 are determined according to the mean travel variation and the tolerance of the travel deviations over the entire usable travel l_u . For tolerances T7-T10 the mean deviation over the length 300 mm is defined at anywhere over the length of thread.

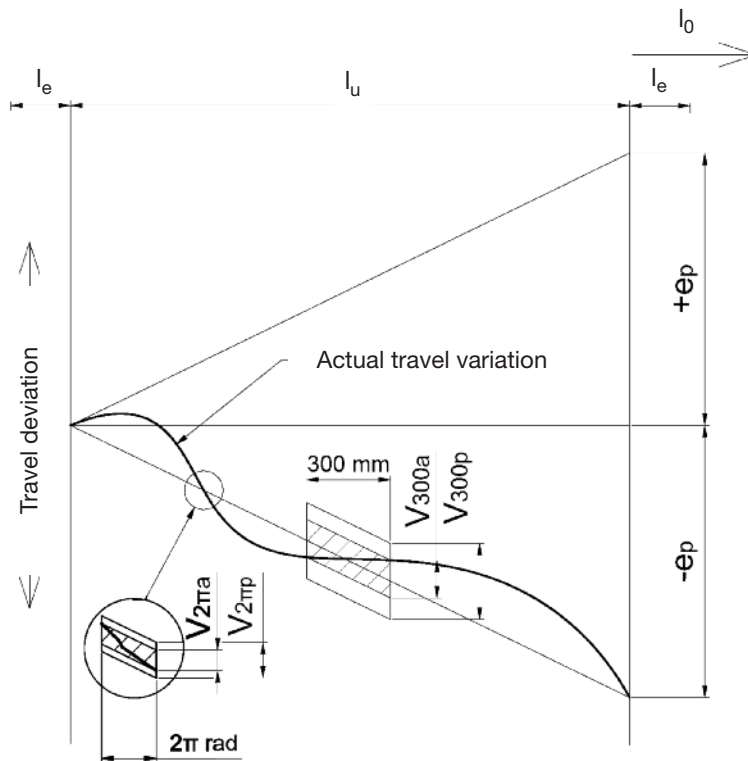

- l_u The usable travel is the stroke plus length of the ball nut.
- l_e The overrun is the axial travel beyond the usable travel serving the safety purpose. The narrowed travel and hardness tolerances for the usable travel are not used.
- l_0 The nominal travel is the axial travel that results from the nominal pitch multiplied with the number of turns with the rotation of the ball nut relative to the ball screw spindle.
- c Travel compensation over the usable travel. Difference between target and actual travel is defined by the user. (Standard $c=0$).
- e_p Upper and lower limit of the target travel form the tolerance fields for the mean travel.
- v_{up} Tolerance of the travel variation above the usable travel l_u .
- v_{300p} Tolerance of the travel deviation for a travel of 300 mm, anywhere over the length of thread.
- $v_{2\pi p}$ Tolerance of the travel deviation within one revolution.

Permissible variances of the intermediate travel variation and the travel fluctuation

Screw length l_u , mm		Tolerance class									
		T0		T1		T3		T5		T7	T10
up	to	e_p	v_u	e_p	v_u	e_p	v_u	e_p	v_u	e_p	v_u
0	315	4	3,5	6	6	12	12	23	23	52 μ m/300mm	210 μ m/300mm
315	400	5	3,5	7	6	13	12	25	25		
400	500	6	4	8	7	15	13	27	26		
500	630	6	4	9	7	16	14	32	29		
630	800	7	5	10	8	18	16	36	31		
800	1000	8	6	11	9	21	17	40	34		
1000	1250	9	6	13	10	24	19	47	39		
1250	1600	11	7	15	11	29	22	55	44		
1600	2000	-	-	18	13	35	25	65	51		
2000	2500	-	-	22	15	41	29	78	59		
2500	3150	-	-	26	17	50	34	96	69		
3150	4000	-	-	32	21	62	41	115	82		
4000	5000	-	-	-	-	76	49	140	99		
5000	6300	-	-	-	-	-	-	170	119		

Tolerance of the travel variation within an interval of 300 mm and a turn (international standards).

Tolerance class	T0	T1	T3	T5	T7	T10
DIN, ISO	3,5	6	12	23	52	210
JIS B 1192	3,5	5	8	18	50	210
DIN, ISO	3	4	6	8	-	-

Running and bearing test according to ISO 3408-3

Measurement of the concentricity, t_5 of the outer diameter of the ball screw spindle over the length l_5 for determining the straightness relative to AA'

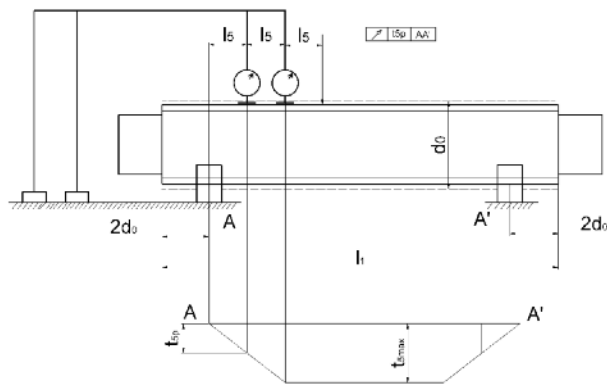

Nominal diameter d_0 in mm		I5	t5p in μm per I5 interval per tolerance class					
Above	to		0	1	3	5	7	10
6	12	80						
12	25	160						
25	50	315	16	20	25	32	40	80
50	100	630						
100	200	1250						
Nominal diameter l_1/d_0		to	t5maxp in μm per $l_1 > 4 \times I_5$					
Above	to		0	1	3	5	7	10
-	40	40	32	40	50	64	80	160
40	60	48	60	75	96	120	240	
60	80	80	100	125	160	200	400	
80	100	128	160	200	256	320	640	

Measurement of the concentricity variation $t_{6.1}$ of the bearing seat relative to AA' over the length l

(Length $l_6 \leq l$). For length $l_6 > l$ must be applicable $t_{6.1a} \leq t_{6.1p} \frac{l_6}{l}$

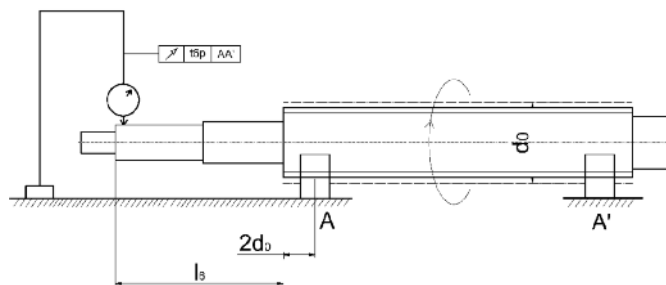

Nominal diameter d_0 in mm		l in mm	t6.1p in μm per l per tolerance class				
Above	to		1	3	5	7	10
6	20	80	10	12	20	40	63
20	50	125	12	16	25	50	80
50	125	200	16	20	32	63	100
125	200	315	-	25	40	80	125

Measurement of the concentricity variation $t_{7.1}$ of the shaft-diameter relative to the bearing seat (C),

by subtraction for the length, $l_7 \leq l$. For length $l_7 > l$ must be applicable $t_{7.1a} \leq t_{7.1p} \frac{l_7}{l}$

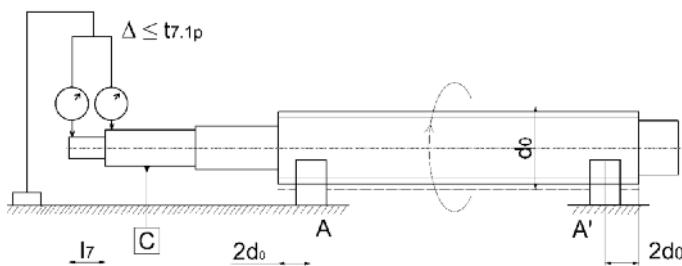

Nominal diameter d_0 in mm		l in mm	t7.1p in μm per l per tolerance class				
Above	to		1	3	5	7	10
6	20	80	5	6	8	12	16
20	50	125	6	8	10	16	20
50	125	200	8	10	12	20	25
125	200	315	-	12	16	25	32

Measurement of the axial runout variation $t_{8.1}$ of the contact surface for bearing relative to AA'

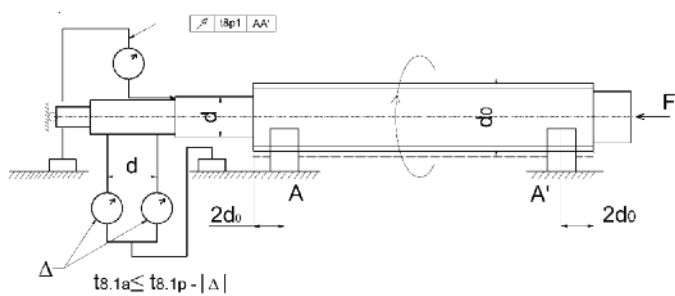

Nominal diameter d_0 in mm		t8.1p in μm per tolerance class				
Above	to	1	3	5	7	10
6	63	3	4	5	6	10
63	125	4	5	6	8	12
125	200	-	6	8	10	16

Measurement of the axial runout variation t_9 of the contact surface of the ball nut relative to AA' (only for preloading ball nuts)

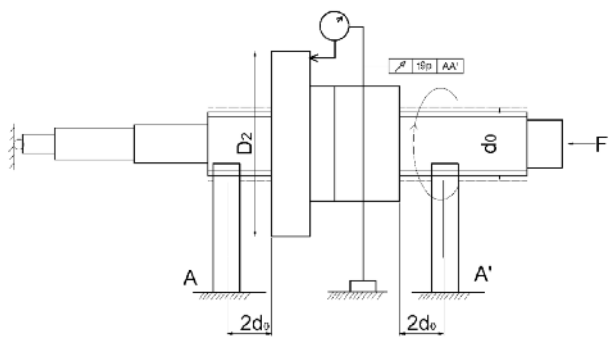

Flange diameter D2 in mm		t9p in μm per tolerance class					
Above	to	0	1	3	5	7	10
16	32	8	10	12	16	20	-
32	63	10	12	16	20	25	
63	125	12	16	20	25	32	
125	250	16	20	25	32	40	
250	500	-	-	32	40	50	

Measurement of the concentricity variation t_{10} of the outer diameter of the ball nut relative to AA' (only for preloading ball nuts)

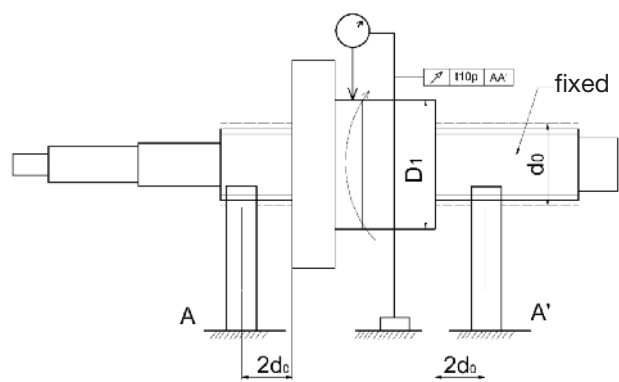

Outside diameter D1 in mm		t10p in μm per tolerance class					
Above	to	0	1	3	5	7	10
16	32	8	10	12	16	20	-
32	63	10	12	16	20	25	-
63	125	12	16	20	25	32	-
125	250	16	20	25	32	40	-
250	500	-	-	32	40	50	-

Parallelity variance t_{11} of a rectangular ball nut relative to AA' (only for pre-loaded ball nuts)

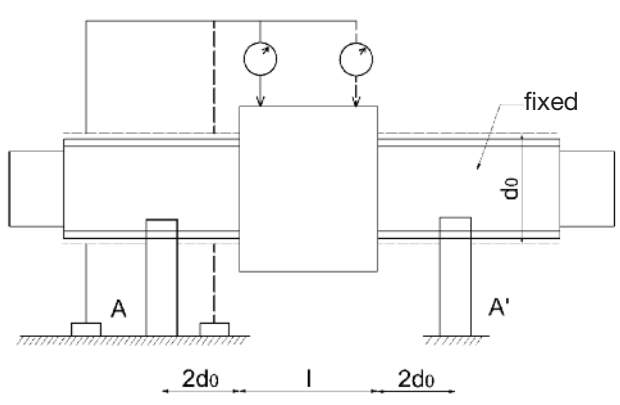

t11p in μm per 100 mm (cumulative) per tolerance class					
0	1	3	5	7	10
14	16	20	25	32	-

Functional tests according to ISO 3408-3

Measurement of the drag torque at preloading ΔT_p

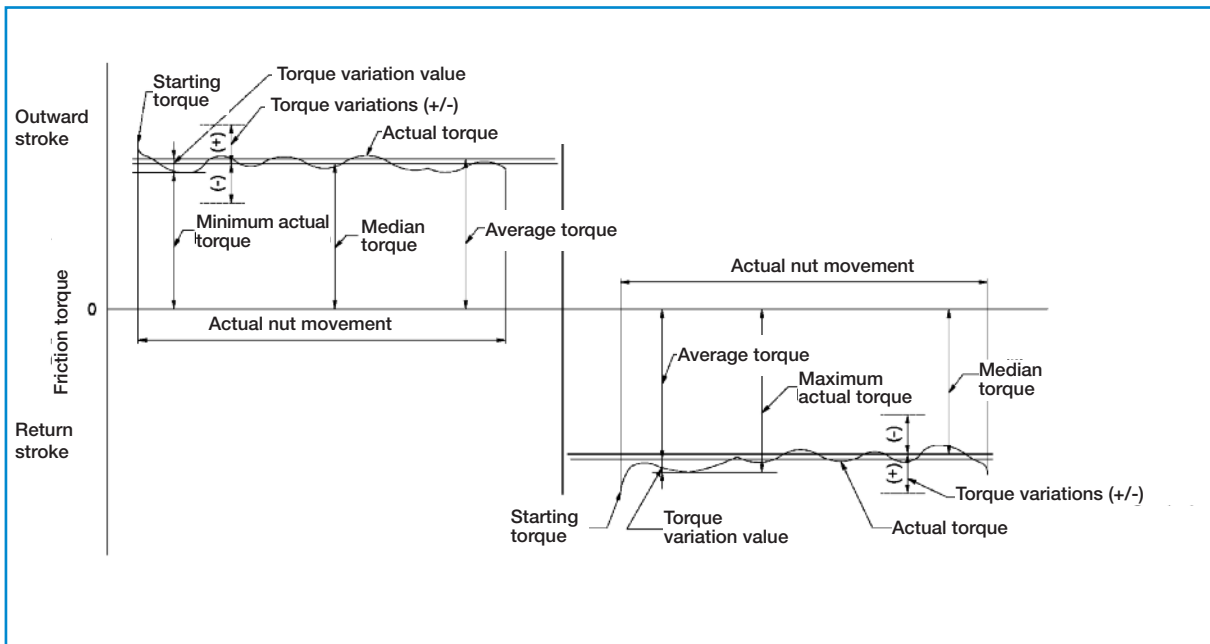

Drag torque through preloading T_{pr}

The torque at the ball screw that is required to turn the ball nut against ball screw (or vice versa) without external load. Possible friction torques due to the sealing elements are not considered.

Total drag torque T_t

The torque that is required to turn the ball nut against ball screw (or vice versa) without external load, inclusive of the friction torques.

Torque variation

Fluctuation value of the predefined drag torque under preload. A positive or negative value relative to the mean torque.

Measuring method

Preloading generates a dynamic friction torque between the nut and the thread. This is measured by moving the threaded spindle at a constant speed, whilst the nut is held with a special locking device. The force F (F_t) measured by the force transducer is used to calculate the friction torque of the threaded spindle.

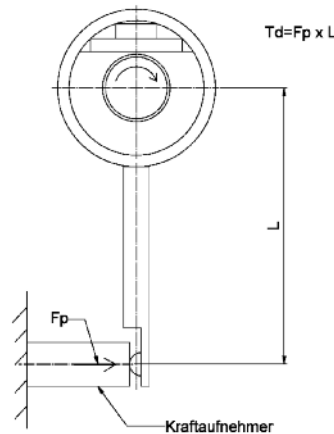

Load cell

Average torque T_{p0} [Nm]		Total length [mm]												
		Up to 4,000										From 4,000 to 10,000		
		$40 < \frac{\text{Threaded length}}{\text{Screw diameter}} \leq 60$						$\frac{\text{Threaded length}}{\text{Screw diameter}} \leq 40$				-		
		ΔT_{pp} (in % up to T_{p0}) Tolerance class						ΔT_{pp} (in % up to T_{p0}) Tolerance class				ΔT_{pp} (in % up to T_{p0}) Tolerance class		
Up	to	0	1	3	5	7	0	1	3	5	7	3	5	7
0,2	0,4	±30%	±35%	±40%	±50%	-	±40%	±40%	±50%	±60%	-	-	-	-
0,4	0,6	±25%	±30%	±35%	±40%	-	±35%	±35%	±40%	±45%	-	-	-	-
0,6	1,0	±20%	±25%	±30%	±35%	±40%	±30%	±30%	±35%	±40%	±45%	±40%	±45%	±50%
1,0	2,5	±15%	±20%	±25%	±30%	±35%	±25%	±25%	±30%	±35%	±40%	±35%	±40%	±45%
2,5	6,3	±10%	±15%	±20%	±25%	±30%	±20%	±20%	±25%	±30%	±35%	±30%	±35%	±40%
6,3	10	-	-	±15%	±20%	±30%	-	-	±20%	±25%	±35%	±25%	±30%	±35%

Axial clearance and preloading

Through the preloading the axial clearance of the ball screw is removed and the stiffness is increased. In addition the positional accuracy is also improved.

The preloading of the single nut is achieved by installing balls of selected dimensions.

The preloading of the double nut is created by tensioning two nuts against each other.

Combination of axial clearance and preloading

Symbol	0	1	2	3	4
Axial clearance	yes	no	no	no	no
Preloading	no	no	light	medium	high
% of dynamic load rating	-	-	~3	~5	~7

	CI	SK	SC	DC	SU	DU	SE
0	•	•	•	•	•	•	•
1	•	•	•	•	•	•	•
2	•		•	•	•	•	
3				•		•	
4				•		•	

Combination of axial clearance 0

Spindle diameter [mm]	rolled ball screw axial clearance [mm]
04-14	0,05
15-40	0,08
50-100	0,12

Critical speed of ball screws

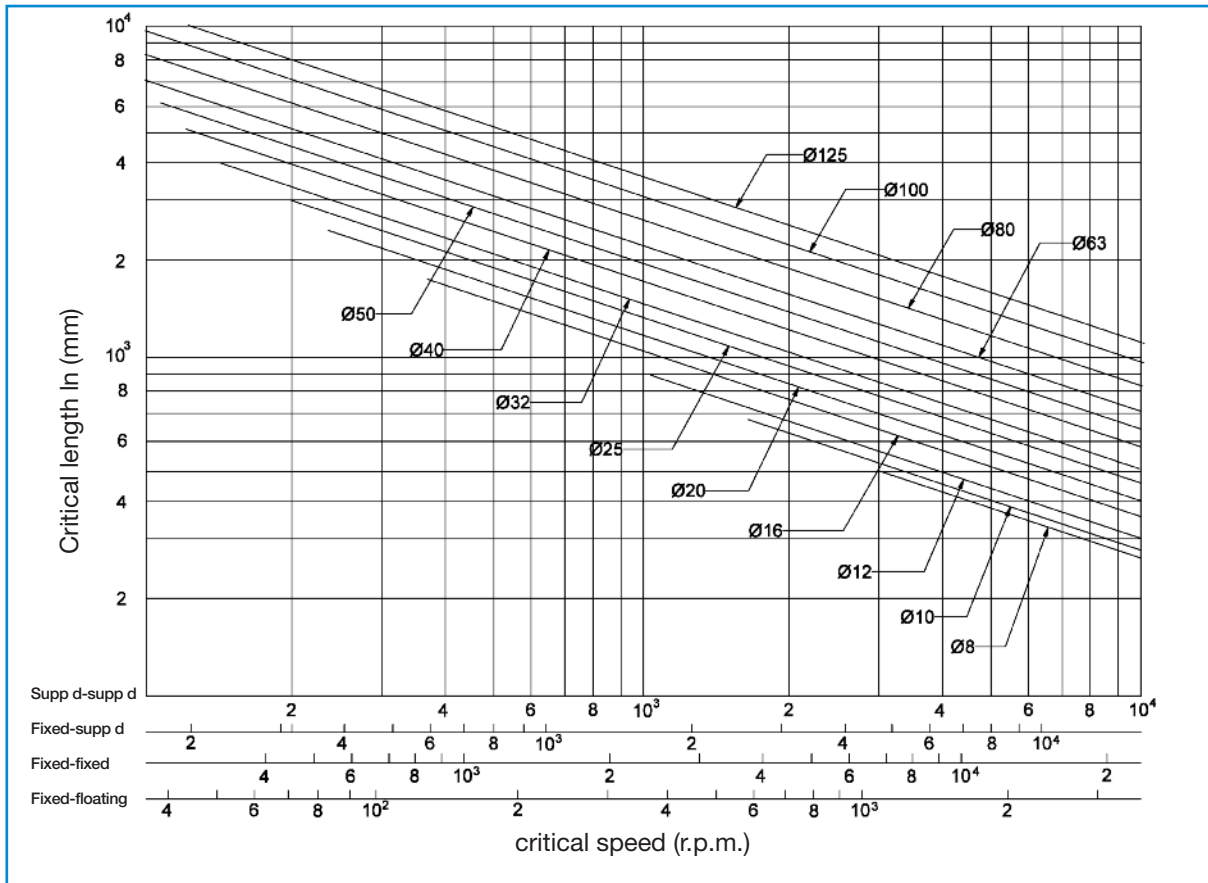

As with any rotating shaft, a ball screw has a critical speed, which is a harmonic vibration. Running the ballscrew in the critical speed area consistently will shorten its operational life, and could affect the performance of a machine as the vibration passes through the machine chassis. For example: On a machine tool it could cause flaws in the surface finish as ball screw reaches its critical speed, as the vibration is transmitted to other parts of the machine. The critical speed is a function of the diameter and length of the ball screw shaft, and the mounting configuration. The axial clearance of the nut has no influence on the critical speed n_k .

The operating speed should be kept at or below 80% of the critical speed. The formula below, for calculating the admissible speed n_{kzyl} , takes account of this 0.8 safety factor.

$$n_{kzyl} = \alpha * \frac{60 * \lambda^2}{2 * \pi * l_k^2} \sqrt{\frac{E * I * g}{\gamma * A}} = f * \frac{d_2}{l_k^2} * 10^7$$

(1/min)

The maximum permissible speed of the ball screw is limited by the DN value in addition to the critical speed.

For the nuts SC/DC

$$d_0 * n_{kzyl} \leq 120.000$$

For the nuts CI, SK, SU/DU, SE

$$d_0 * n_{kzyl} \leq 90.000$$

d_0 Centre diameter of the spindle, mm

Please contact our application engineers if the required speed exceeds the DN value, or the ball screw is used for higher speeds.

n_k	critical speed (r.p.m.)
n_{kzyl}	permissible operating speed (r.p.m.)
α	safety factor (=0.8)
E	elasticity modulus ($E=2.06 \times 10^5$ N/mm ²)
I	geometric moment of inertia (mm ²)
d_2	diameter at the ball screw root (mm)
γ	specific material density ($7,6 \times 10^{-5}$ N/mm ³)
g	earth's gravitational constant ($9,8 \times 10^3$ mm/s ²)
A	cross section of the ball screw (mm ²)
l_k	unsupported length between the two housings
f	correction factor due to mounting
supported-supported	$\lambda=3,14$ $f=9,7$
fixed-supported	$\lambda=3,927$ $f=15,1$
fixed-fixed	$\lambda=4,730$ $f=21,9$
fixed-floating	$\lambda=1,875$ $f=3,4$

Permissible axial load for the screw (buckling)

Similar to any shaft, ball screws can only withstand a limited axial load. Any stress greater than the maximum defined values can lead to failure of the screw. The permissible axial compression is a function of the length, diameter and the type of mounting of the screw. The maximum axial compression load should be 50% or less of the theoretical permissible load. The calculation made using the formula below takes this safety factor into account.

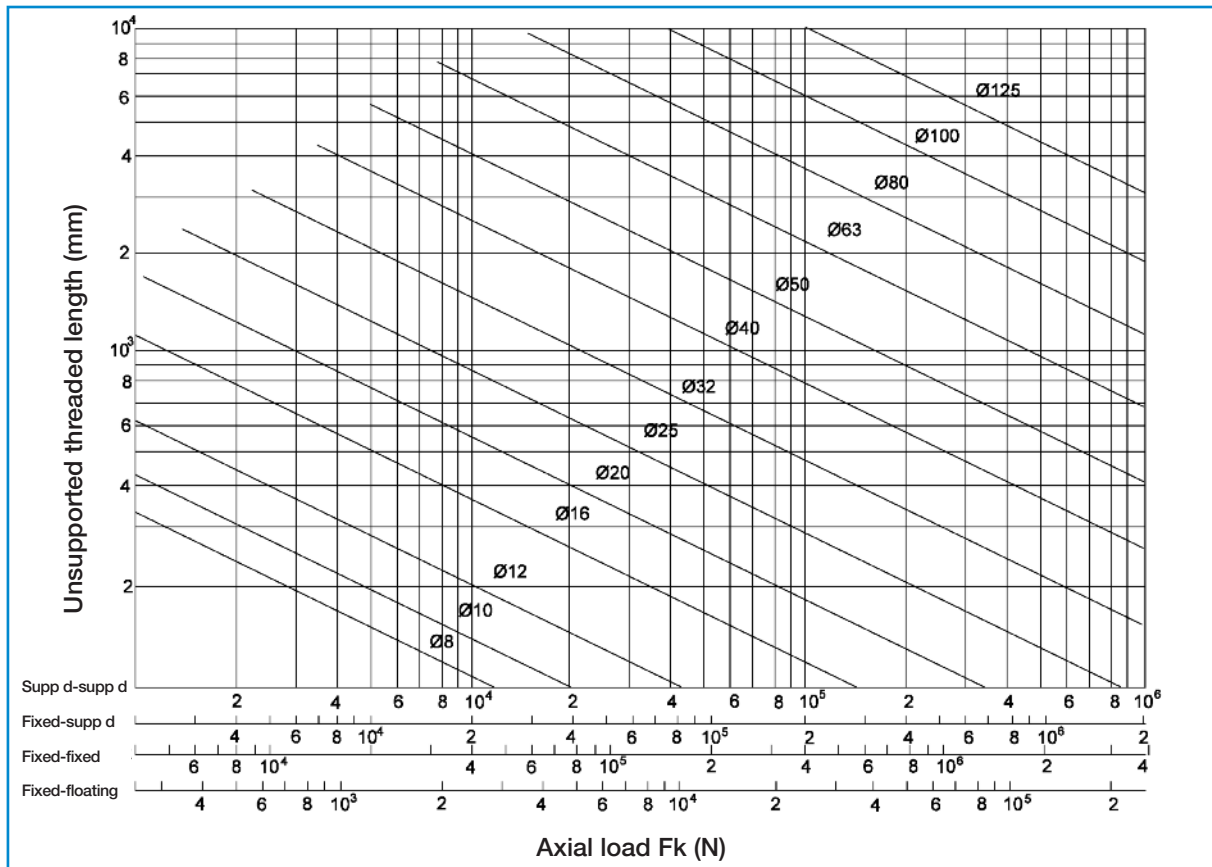

F_k theoretical maximum permissible axial load (N)
 F_{kzyl} maximum permissible working axial load (N)
 α safety factor (=0,5)
 E modulus of elasticity
 ($E = 2,06 \cdot 10^5 \text{ N/mm}^2$)

$$F_{kzyl} = \alpha \cdot \frac{N \cdot \pi^2 \cdot E}{l_k} = m \cdot \frac{d_2^4}{l_k} \cdot 10^3 \text{ (N)}$$

l geometric moment of inertia
 $l = \frac{\pi}{64} \cdot d_2 \text{ (mm}^4\text{)}$

d_2 diameter at the ball screw root (mm)
 l_k unsupported length between the two housings (mm)
 m, N factor linked to the

supported-supported	$m=5,1$	$N=1$
fixed-supported	$m=10,2$	$N=2$
fixed-fixed	$m=20,3$	$N=4$
fixed-floating	$m=1,3$	$N=0,25$

Calculation basis

Average speed and average load:

In the event of variable operating conditions (speed and load), the working life calculations will rely on the average values F_m and n_m

For the average speed n_m , in the case of variable speed, apply

$$n_m = \frac{q_1}{100} \cdot n_1 + \frac{q_2}{100} \cdot n_2 + \dots + \frac{q_n}{100}$$

n_m = average speed (r.p.m.)
 q = time (%)

For the average load F_m , in the case of a variable load, apply

$$F_m = \sqrt[3]{F_1^3 \cdot \frac{q_1}{100} + F_2^3 \cdot \frac{q_2}{100} + \dots + F_n^3 \cdot \frac{q_n}{100}}$$

F_m = average load (kN)
 q = movement or time at constant speed (%)

For the average load F_m , in the case of both variable load and speed, apply

$$F_m = \sqrt[3]{F_1^3 \cdot \frac{n_1}{n_m} \cdot \frac{q_1}{100} + F_2^3 \cdot \frac{n_2}{n_m} \cdot \frac{q_2}{100} + \dots + F_n^3 \cdot \frac{n_n}{n_m} \cdot \frac{q_n}{100}}$$

F_m = average load (kN)
 q = time (%)
 n_m = average speed (r.p.m.)

Nominal working life

Working life L , expressed in revolutions

$$L = \left(\frac{C_a}{F_m}\right)^3 \cdot 10^6 \Rightarrow C_{a\min} = F_m \cdot \sqrt[3]{\frac{L}{10^6}}$$

L = working life (in r.p.m.)
 F_m = average load (kN)
 C_a = dynamic load capacity (kN)

Working life, expressed in hours L_h

$$L_h = \frac{L}{n_m \cdot 60 \cdot ED}$$

L_h = working life (h)
 L = working life (in revolutions)
 n_m = average speed (r.p.m.)
 ED = operating time (%)

Motor torque and output power

Output torque M_{ta}

for the transformation of rotational movement into linear movement

$$M_{ta} = \frac{F \cdot P}{2 \cdot \pi \cdot \eta}$$

M_{ta} = output torque (Nm)

M_{te} = resistive torque (Nm)

F = actual load (kN)

P = pitch (mm)

η = yield (approx. 0.9)

η = yield (approx. 0.8)

Resistive torque M_{te}

for the transformation of linear movement into rotational movement

$$M_{te} = \frac{F \cdot P \cdot \eta}{2 \cdot \pi}$$

For preloaded double nuts, take no-load torque into account.

Output power P_a

$$P_a = \frac{M_{ta} \cdot n}{9550}$$

P_a = output power (kW)

M_{ta} = output torque (Nm)

n = speed of rotation (1/min)

Mounting the nut on the screw

In case of separate delivery of ball screws and ball nuts, qualified personnel must carry out the assembly of the ball screws. Ball nuts should be mounted only with the help of a fitting sleeve. The fitting sleeve delivered with the nut unit can be used. The start of the thread of the spindle must be aligned, so that the wiper and the internal single parts of the nut unit are not damaged.

As standard SNR ball screws are delivered with an installed nut unit. The nut unit and spindle should not be dismantled (especially applicable for a preloaded nut). If this is unavoidable, please contact our application engineers.

Proceed with the mounting as follows:

Remove the rubber washer from one side of the sleeve. Push on the nut with the sleeve on the end of the screw. Press the sleeve against the start of the screw thread.

Screw the nut on to the thread, using a slight axial pressure. Then screw the nut on for its entire length.

Remove the mounting sleeve only when the nut is completely threaded on to the screw. Lock the nut to prevent any unscrewing (using a rubber washer or fixing the sleeve axially).

What do I do when...

Balls escape while threading on the nut?

1. Pick up the balls (the nut is only compatible with the original balls). The load capacity is then ensured, even if two or three balls are missing.
2. Carefully clean all the components.
3. Use the sleeve as a mounting jig.
4. Replace the balls.
5. Start with the lowest circuit. Insert the balls into the nut circuit, the sleeve prevents the balls from falling inside.

Note:

Ground ball screws, with a single or double nut are always delivered with the nut assembly mounted, similarly to rolled double nut screws.

Please contact us if you absolutely must dismantle a nut assembly.

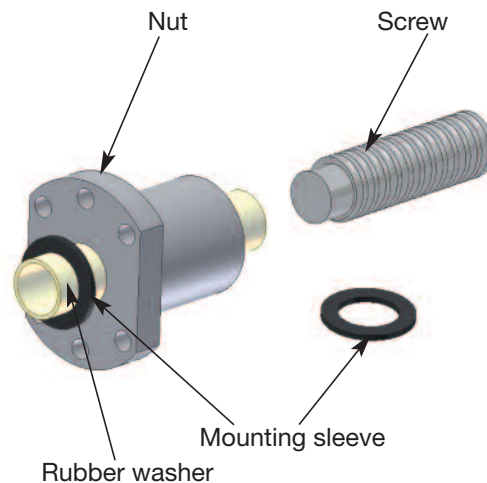

Important:

Use only the original balls!

Important:

Do not place the balls in the empty circuit located between the two deflectors!

Operating and maintenance information for the ball screws

Operating conditions

In addition to the load rating, the maximum speed, critical bending speed and the permissible buckling force should also be considered. Ball screws are conceptualised as a drive element for creating axial feed force. Radial forces and torques that have an impact on the nut, lead to the reduction of durability. When using a ball screw the ambient temperature shall not exceed 80°C.

Assembly

During assembly, parallel alignment of the guiding elements should be ensured. Special care must be taken to achieve a concentric assembly of the nut on the spindle. Here attention should be paid to the tolerance relationship between the guiding elements and layout as well as the bearing units and nut housings. By providing alignment options to the nut or to the bearing, good accuracy with lower cost can be realised.

Lubrication

For maintaining the performance of a ball screw, it must be lubricated adequately. Similar lubricants that are used for rolling bearings should be used. Lubricants containing MoS₂ or graphite should not be used. The selection of the lubricant and the type of supply can be adjusted to match the lubrication of the other components of the machine. A one off lifetime lubrication of the ball screw is not adequate based on experience, as the spindle constantly discharges small amounts of lubricant from the nut.

SNR – ball screws are supplied with the conserving oil “Contraktor Fluid H1”. “Contraktor Fluid H1” is compatible with the SNR standard lubricant “SNR LUB Heavy Duty”.

The lubrication period is dependent on many factors such as:

- Load
- Speed
- Motion sequence
- Temperature

The following factors reduce the lubrication interval:

- Greater load
- High speed
- Short stroke (stroke is smaller than three times the length of the nut)
- Lower ageing resistance of the lubricant

Grease lubrication

For operation under normal conditions, grease SNR Heavy Duty is used. Specific requirements under certain environmental conditions require the use of a suitable grease. In the food industry and clean room there are special requirements for the lubricant with regard to emission and compatibility. Basically the compatibility of the lubricants against each other should be checked. In case of special ambient conditions we will gladly assist you. Depending on the area of application the following lubricants can be used:

Name	Oil type, consistency	NLGI-class DIN 51818	Walk penetration DIN ISO 2137 at 25°C	Ground oil viscosity DIN51562 at 40°C	Density	Temperature range	Properties	Field of application
			[0,1 mm]	[mm²/s]	[kg/m³]	[°C]		
SNR LUB Heavy Duty	Paraffin mineral oil / Lithium – Special - Soap	2	285	ca. 105	890	-30...+110	Lower friction, smooth running	General engineering
SNR LUB GV+	Synthetic KW oil / ester oil / Lithium – Special - Soap	2	265...295	24	900	-50...+120	Very good adhesion, very good water resistance	High speeds
SNR LUB HIGH TEMP	Synthetic KW oil / mineral oil / polyurea	2	265...295	160	900	-40...+160	High temperature resistance, good corrosion protection, high oxidation resistance	High temperature range
SNR LUB FOOD	Paraffin mineral oil / aluminium complex soap	2	265...295	ca. 240	920	-30...+110	Good corrosion protection, very good adhesion, high water resistance, NSF H1 registered*	Food industry
Microlub GL261	Mineral oil / Lithium – Special - Soap	1	310...340	280	890	-30...+140	Good wear protection, special pressure resistance additive against tribo corrosion	general engineering high load short-stroke applications, vibrations
Klübersynth BEM34-32	Synthetic CW - oil / special - calcium soap	2	265...295	ca. 30	890	-30...+140	Particularly pressure resistant, good wear protection, good ageing resistance low starting torque	Clean-room applications
Klübersynth UH1 14-151	Synthetic CW oil/ester oil / aluminium complex soap	1	310...340	ca. 150	920	-45...+120	Good corrosion protection, good ageing resistance, high water resistance, NSF H1 registered*	Pharmaceutical industry Food industry

** This grease is registered as H1 product: it has been developed for occasional, technically unavoidable contact with foodstuff. Experiences have shown that the grease can also be used for the corresponding applications in the pharmaceutical and cosmetic industry, on the conditions listed in the product information. However, there are no specific test results, for instance, on the biocompatibility, as may be required under certain circumstances in the pharmaceutical area. Therefore, before it is used in this area by equipment manufacturers and distributors, corresponding risk analyses must be performed. If necessary, measures to avoid health hazard and injuries must be taken. Source: Klüber Lubrication)*

At higher speeds (speed parameter $DN > 50,000$) the quality K1K or KP1K should be selected. Speed parameters under 2,000 require a grease of the consistency class 3 (K3K or KP3K DIN 51825). The required lubrication period is based on the ambient conditions. In general re-lubrication should be carried out every 200-600 operating hours. The following is applicable as a reference value for the lubricant quantity: Per cm spindle diameter ≥ 1 cm³ grease for each nut. Only greases of same soap base should be used for lubrication.

Oil lubrication

As a rule, oil lubrication is used in conjunction with centralised lubrication equipment. The advantage of centralised automatic oil lubrication is a continuous lubricant supply to all the lubrication points. Lubricant oils ensure a very good dissipation of friction heat. In contrast there are higher design and assembly requirements for the lubrication lines. Depending on the area of application the following lubricant oils can be used:

Name	Type of lubricant	Kinematic viscosity DIN51562 at 40°C	Density	Temperature range	Properties	Field of application
		[mm ² /s]	[g/cm ³]	[°C]		
Klüberoil GEM 1-100N	Mineral oil	100	880	-5....+100	Good corrosion and wear protection	General engineering
Klüberoil 4 UH1-68N	Polyalphaolefin	680	860	-25....+120	good ageing and wear protection	Food industry
					NSF H1 registered*	Pharmaceutical industry

** This grease is registered as H1 product: it has been developed for occasional, technically unavoidable contact with foodstuff. Experiences have shown that the grease can also be used for the corresponding applications in the pharmaceutical and cosmetic industry, on the conditions listed in the product information. However, there are no specific test results, for instance, on the biocompatibility, as may be required under certain circumstances in the pharmaceutical area. Therefore, before it is used in this area by equipment manufacturers and distributors, corresponding risk analyses must be performed. If necessary, measures to avoid health hazard and injuries must be taken. Source: Klüber Lubrication)*

At higher speeds (speed parameter $DN > 50,000$) oils of the viscosity class ISO VG 46-22 should be used. For speed parameters under 2,000 the viscosity ISO VG 150-460 should be used. If the load is above 10% of the dynamic load rating, an oil with additives is recommended for increasing the load capacity (class CLP, DIN 51517 Part 3). With oil bath lubrication the spindle must be 0.5 to 1 mm above the oil level. The oil supply with re-circulation lubrication should be 3 cm³/h for each ball circulation.

Type designation code

(1) Product

BSC Screw + Nut assembly
 BSH Ball screw
 BNU Nut alone

(2) Nominal diameter (mm)

(3) Pitch (mm)

(4) Direction of pitch

R right
 L left

(5) Type of nut

CI Single cylindrical nut (Page 7)
 SK Single flanged miniature nut (Page 6)
 SE Single flanged nut (wide pitch) (Page 12)
 SC Single flanged compact nut to DIN 69051 (Page 8)
 DC Double flanged compact nut to DIN 69051 (Page 9)
 SU Single flanged nut to DIN 69051 (Page 10)
 DU Double flanged nut to DIN 69051 (Page 11)
 SH Single threaded nut (Page 13)

For the coding of screws alone:

01 Screw for compact series DIN nut
 00 Screw for special nut types

(6) Number of circuits

(7) Type of flange

A DIN 69051 section 5 form A (round)
 B DIN 69051 section 5 form B
 C DIN 69051 section 5 form C
 Z Cylindrical nut

(8) Precision class (Page 22)

T0, T1, T2, T3, T5, T7 (in stock), T10

(9) Model

G ground
 R rolled

(10) Preload types (Page 26)

0 Standard axial clearance
 1 No axial clearance
 2 Light preload
 3 Medium preload
 4 High preload

(11) Total length (mm)

(12) Right side screw end (Pages 19-20)

F, S Form F, S (X depending on customer drawing, 0 with no end machining)
 1, 2 Model
 6...60 Diameter of the bearing seat

(13) Left side screw end, see right side screw end

(14) Lubrication

0 Standard nut greasing
 1 Anti-corrosion greasing
 2 Greasing to customer instructions

(15) Special

0 None
 1 Taking account of drive torque measurement
 2 Taking account of pitch error

Screw + Nut assembly BSC 020 05 R Cl 2 Z T7 R 0 - 1000 - F115 - S115 - 0 - 0

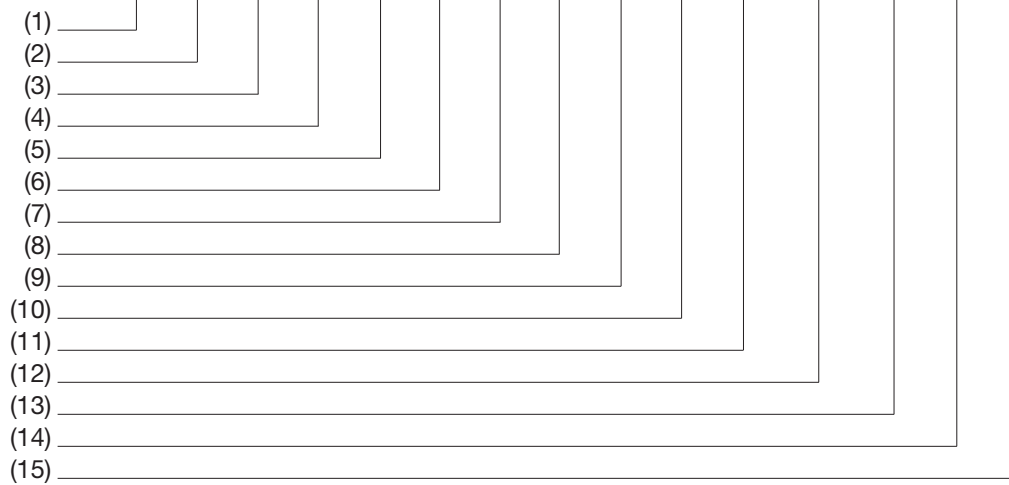

Nut

BNU 020 05 R Cl 2 Z R - 0

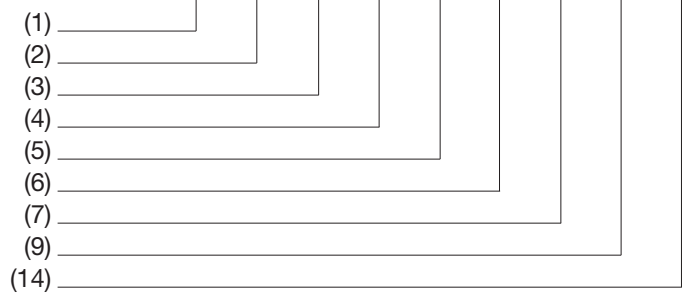

Screw

BSH 020 05 R 00 T7 R - 1000 - F115 - S115 - 0

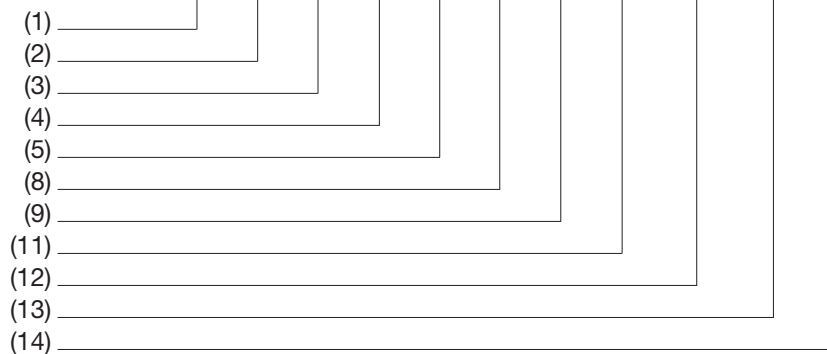

Your enquiry form

Company _____

Address _____ Contact _____

Position _____ Telephone _____ Fax _____

Description of the application _____

<input type="checkbox"/> Isolated need	No. of pieces	<input type="checkbox"/> New construction
<input type="checkbox"/> Production need	Required delivery _____ Weeks	<input type="checkbox"/> Technical improvement
	Pieces per year _____	<input type="checkbox"/> Cost reduction / Current price _____ €
	Delivery of _____ pieces required in _____ Weeks	

Application parameters

Type of mounting: <input type="checkbox"/> Horizontal <input type="checkbox"/> Vertical	Usable stroke: _____
Maximum usable load: _____ kg	Additional axial load: _____
Maximum movement speed: _____ m/s	Maximum acceleration: _____
Positioning accuracy: _____ mm	Reproducibility: _____ mm
Maximum inversion clearance: _____ mm	Cycle time: _____ sec
Required working life _____ strokes or _____ hours	

Ambient conditions of use: _____

Special circumstances: _____

Dimensions and features, if existing application

<input type="checkbox"/> Flange nut:	Maximum dimensions of the nut: _____
<input type="checkbox"/> Cylindrical nut	Nominal screw diameter: _____ mm
<input type="checkbox"/> DIN nut	Pitch: _____ mm
	Total length: _____ mm

Housings

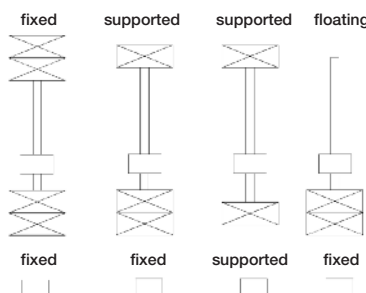
	<input type="checkbox"/> With machining of the ends to drawing no. <input type="checkbox"/> Machining of the ends for use with SNR housings <input type="checkbox"/> No end machining
---	---

The consultation of SNR WÄLZLAGER GMBH is exclusive for the function of the ball screws. As a supplier of a component SNR accepts no liability for the function, operation or performance for the machine, system or assembly to which the ball screw is mounted. This responsibility lies with the machine designer, manufacturer, operator or other relevant parties.

More information concerning our NTN-SNR products for linear motion is provided in our catalogues.



**NTN-SNR Linear Motion
Linear modules**



**NTN-SNR Linear Motion
We get you moving**

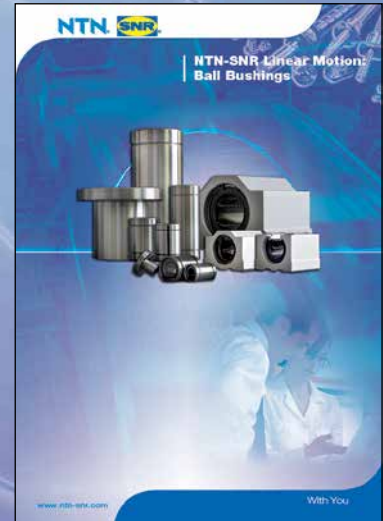

**NTN-SNR Linear Motion
Ball bushings**



**NTN-SNR Linear Motion
Ball splines**

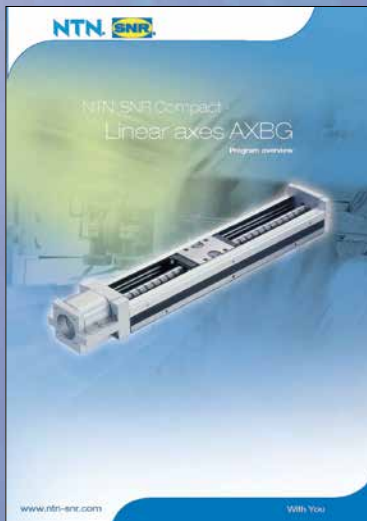

**NTN-SNR Linear Motion
AXBG**

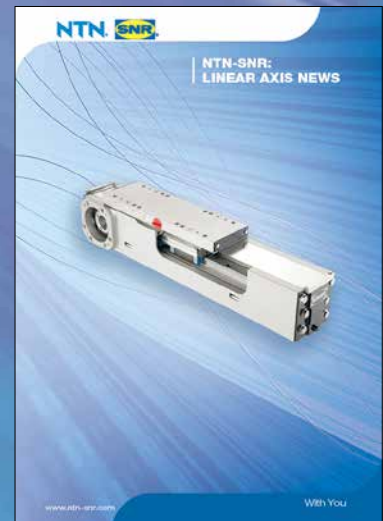

**NTN-SNR Linear Motion
Linear axis news**



contatto
contatto

お問い合わせ

contacto
contacto

contact
contact

www.ntn-snr.com

الاتصال ب

contacto
contacto

联系我们
Lian xi wǒ men

Kontakt
Kontakt

AUTOMOTIVE / AEROSPACE / INDUSTRY

DOC_I_BS_CAT3.GBa - Code SAP: 0000000 Non contractual document - NTN-SNR Copyright International - 10/2014 - Photos : Pedro Studio Photo