



Linear and Motion Solutions

Adjusting locking/unlocking nuts and rings

LR, LRE, LF, LFE, LRP, LX



GS 408 E

Adjusting locking/ unlocking nuts and rings LR, LRE, LF, LFE, LRP, LX

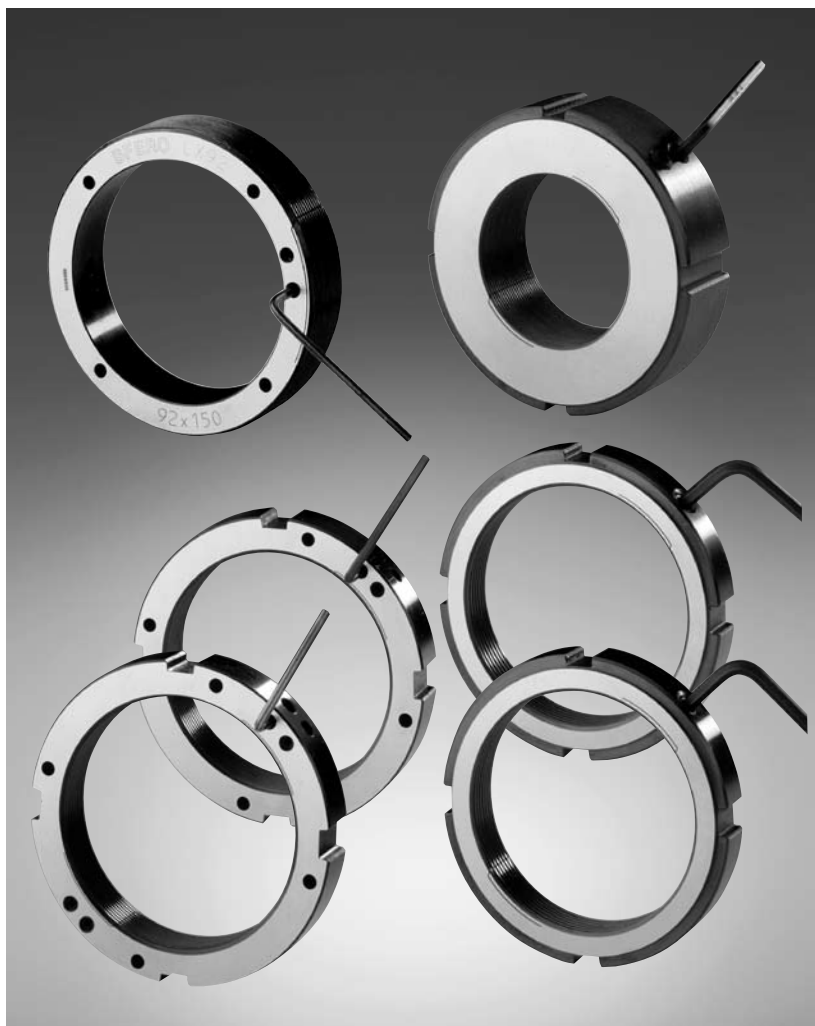

NADELLA

Adjusting locking/ unlocking nuts and rings LR, LRE, LF, LFE, LRP, LX

Applications:

- Transmissions
- Machine-tool
- Textile machinery
- Printing industry
- Conditioning
- Special machinery
- Automotive industry
- Engine/turbine manufacturing
- Onshore and offshore industry
- Transportation
- Aeronauticals
- Marine equipment
- Nuclear industry
- Agriculture and Food industry
- Civil and military engineering
- Precision optical attachments

The threaded spring nuts and rings are used whenever precision mechanisms require a precision clamping as well as a powerful and safe locking:

- Power transmission and motion technology
- Adjusting and clamping all types of bearings
- Mount/release of ball bearings
- Elimination of back lash
- Securing mechanical safety devices
- Templating spring-mounted measuring systems
- Safety nuts for use in high-temperature applications
- Periodical mounting and dismounting of adjusting locking/unlocking nuts and rings
- Assemblies subjected to vibrations
- Cyclic uneven rotation
- High and very high rotation spindle/shaft assemblies

- Frequent clockwise and counterclockwise reversing rotation systems
- Reduction of inertias through the use of selected materials (Titanium alloys and Aluminium alloys).

Spring nuts and rings

Latest range of spring nuts and rings comprises 6 different models of adjusting locking/unlocking devices featuring the same securing technique through a threaded locking spring.

CLAMPING	Radial	Axial
Standard	LR	LF - LX
Balanced	LRE	LFE
Heavy-duty	LRP	

Spring ring

CLAMPING	Axial
Standard	LX

Clamping system

- The threaded bore of the nuts and outside threading of the rings is partially wired EDM to form a clamping spring. When tightening the Hc grub screws clamping is applied with a very strong pressure onto the threaded spring which meshes perfectly into the corresponding threads of the shaft or spindle.
- The contacted threaded surface of the spring pressing onto the threaded surface of the shaft/spindle, amplifies the clamping power, ensuring thereby a highly efficient clamping and making any unlocking hazard or loss of grip almost impossible.

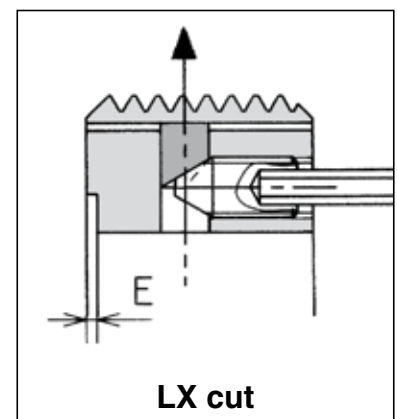
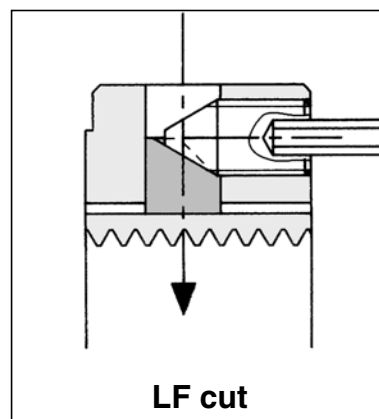
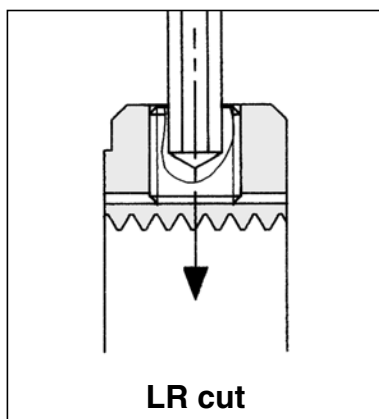

Advantages of the nuts

- **A precise and powerful locking of bearings in axial positioning after assembly.**
- **A higher unlocking torque when compared to other locking techniques.**
- Time-saving through a more **simple technical design** and construction of **shaft-bodies** and assemblies.
- No key slot required as for locking washers. Thus **saving thread deburring** operation.
- **No use of locking washers**, thus preventing seal damage.
- **Clamping and locking** the adjusting nut without **any loss of axial precision.**
- **Easy mount and release** re-usable many times **without loss of precision.**
- Recommended use under severe conditions (**High-temperature, vibrations, etc...**).

Remarks about unlocking torques

Numerous parameters influence the unlocking torque:

- **Precision of the screw-nut assembly**
- **Clamping strength applied to the Hc grub screws** (applying pressure onto the threaded spring)
- Nature of materials and corresponding **surface quality** various heat treatments and coatings
- Environment (temperature, vibrations, atmospheric conditions, etc...)
- Overall toughness of the assembly.

The locking torque and axial loading values on this catalogue are given for static assemblies. They are indicative and do not involve the manufacturers responsibility.

Mounting the nuts and rings

- The mounting occurs by driving the spring nuts and rings clockwise with standard spanner wrench (Din 1810) adapting onto the peripheral notches (b x h) of the nuts.
- The mounting can also easily be achieved thanks to the pin-key holes on the front-side of the nuts with the adequate key.
- Once in the correct position on the shaft/spindle the blocking can be simply secured by turning the Hc grub screws located either on the outside diameter or on the front side of the nuts.
- For nuts showing two locking springs or additional clamping screws (LRE - LFE - LRP) it is recommended to activate these screws alternatively and progressively so as to ensure an efficient locking.
- The use of a torque wrench is recommended so as to achieve a safe clamping of the Hc grub screw with the required value. However, using HEX male keys is also highly efficient.
- Very easy release of the nut through simple unlocking of the Hc grub screws.

Upon request we can provide **mated threaded assemblies** with **fine-ground matching threads** both on the nut and corresponding shaft/spindle.

Nuts and rings in **Titanium alloys, Stainless steels**, for the agricultural and food industries, the nuclear industry, the petro-chemical industry are also available as well as right-hand or left-hand threads.

The main characteristics of the adjusting locking/unlocking nuts and rings are explained in the following pages.



LR NUT

1 Clamping spring

Radial locking

Characteristics

- LR nuts are used wherever a strong radial clamping is required.
- The radial strength activated by turning the Hc grub screw is applied onto the threaded spring.
- The contact surface perpendicular to the threaded side allows the adjusting and locking of all types of bearings as well as other mechanical elements requiring very precise tolerances.

Specifications

- **Material:** High elastic limit steel
- **Peripheral notches:** 4 at 90°
- 
- To ensure squareness and minimum run-out of the nuts and rings, all threading and contact face machining operations are performed in one setting.
- **Grub screw:** Hc type with dog-point tip 14.9
- **Standard manufacturing:**
 - 4H class precision threading
 - right-hand thread
 - Fine-ground contact face
 - Marquing on the opposite side
 - Black oxide

Options

- **Other versions are also available upon request:**
 - Fine-ground threads
 - Left-hand thread
 - 2 twinned screws for increased locking torque
 - Other sizes
 - Other materials

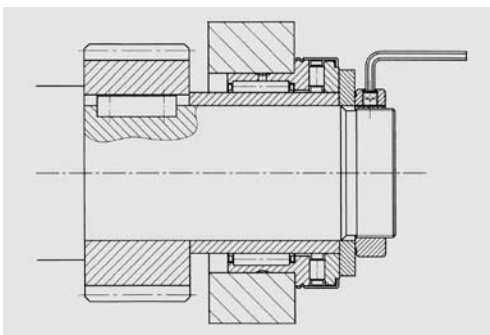

Set up of a combination needle-bearing onto a drill press spindle.

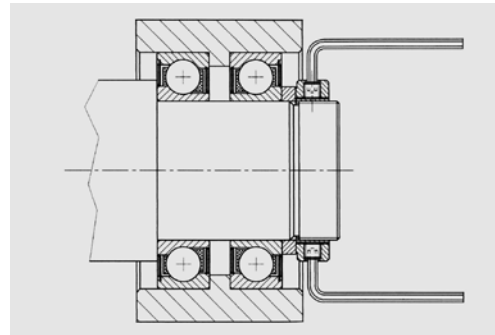

Set up the preloading of angular contact bearings.

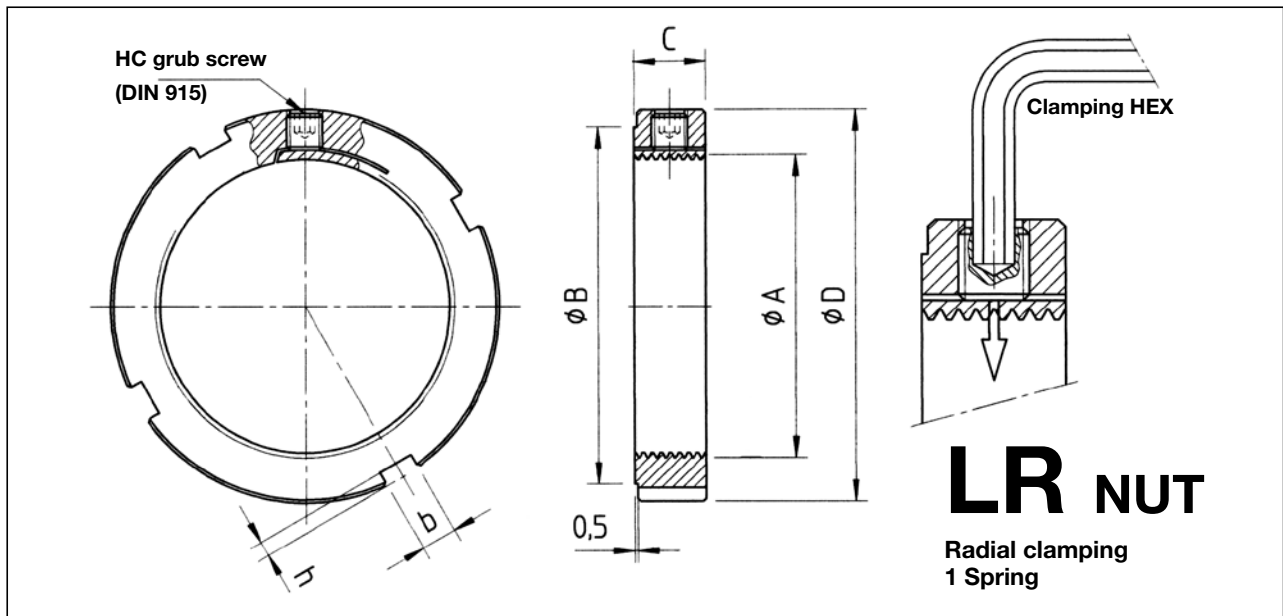

Type	Thread A	Ø D	Ø B	C	b x h	Hc grub screw	Unlocking Torque in Nm*	Max Axial load in Newton	Weight in Kg
LR 1	12 x 1.00	24	19				23	28 500	0,030
LR 2	14 x 1.00	26	21				26	33 500	0,035
LR 3	15 x 1.00	30	25				29	40 500	0,045
LR 4	17 x 1.00	32	27		4 x 2		32	46 100	0,055
LR 5	18 x 1.00	32	27				37	49 000	0,055
LR 6	20 x 1.00	35	30				42	54 600	0,060
LR 7	22 x 1.50	35	30				47	56 600	0,060
LR 8	25 x 1.50	40	35			1	53	67 100	0,070
LR 9	30 x 1.50	45	40			grub screw	59	81 100	0,085
LR 10	32 x 1.50	46	41	12	5 x 2	M 6	65	92 900	0,090
LR 11	35 x 1.50	50	45				75	98 000	0,095
LR 12	38 x 1.50	52	47				83	101 900	0,100
LR 13	40 x 1.50	55	49				94	104 000	0,100
LR 14	42 x 1.50	56	50				105	109 300	0,110
LR 15	45 x 1.50	60	54		6 x 2,5		118	119 200	0,120
LR 16	50 x 1.50	65	59				132	134 900	0,130
LR 17	52 x 1.50	67	61				147	140 400	0,130
LR 18	55 x 2.00	75	68				512	168 900	0,23
LR 19	60 x 2.00	80	73		7 x 3		532	184 600	0,25
LR 20	65 x 2.00	85	78				560	203 500	0,27
LR 21	70 x 2.00	90	82				587	219 500	0,28
LR 22	75 x 2.00	95	87		8 x 3,5		615	237 000	0,30
LR 23	80 x 2.00	105	97				650	255 400	0,42
LR 24	85 x 2.00	110	102			1	675	273 300	0,44
LR 25	90 x 2.00	115	106			grub screw	713	292 300	0,46
LR 26	95 x 2.00	120	111	15	10 x 4	M 8	750	308 800	0,49
LR 27	100 x 2.00	125	116				790	325 300	0,51
LR 28	105 x 2.00	130	119				830	341 700	0,52
LR 29	110 x 2.00	135	124				870	358 200	0,55
LR 30	115 x 2.00	140	129		12 x 5		930	377 000	0,57
LR 31	120 x 2.00	145	134				960	394 000	0,59
LR 32	125 x 2.00	150	139				1040	413 800	0,62
LR 33	130 x 2.00	155	144				> 2000	434 400	0,65
LR 34	135 x 2.00	165	152			1	> 2000	677 000	1,10
LR 35	140 x 2.00	170	157	20	14 x 6	grub screw	> 2000	704 400	1,13
LR 36	145 x 2.00	175	162			M 10	> 2000	729 800	1,15
LR 37	150 x 2.00	180	167				> 2000	757 400	1,20

*Values obtained with Hc grub screws:
 - M 6 screw - clamping torque 8 Nm
 - M 8 screw - clamping torque 18 Nm
 - M10 screw - clamping torque 36 Nm



LRE NUT

2 Symmetrical clamping springs

Balanced radial locking

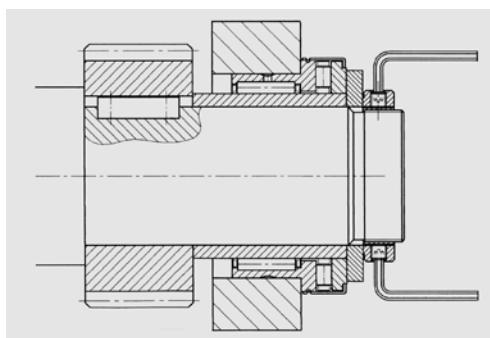

Characteristics

- LRE nuts are used wherever a strong radial clamping is required.
- Featuring 2 symmetrically opposed clamping springs at 180°, these nuts have two advantages when compared to the LR nuts:
 - Improved balance allowing higher rotation speeds
 - Twice as much unlocking torque for the same size.
- The radial strength activated by turning the 2 Hc grub screws is exercised onto the threaded clamping spring.
- The contact surface perpendicular to the threaded side allows the adjusting and securing of all types of bearings as well as other mechanical elements requiring very precise tolerances.



Adjusting of a combination needle-bearing onto a drill press spindle.

Specifications

- **Material:** High elastic limit steel
- **Peripheral notches:** 4 at 90°
-  
 - To ensure squareness and minimum run-out of the nuts and rings, all threading and contact face machining operations are performed in one setting.
- **Screw:** Hc type with dog-point tip 14.9
- **Standard manufacturing:**
 - 4H class precision threading
 - right-hand thread
 - Fine-ground contact face
 - Marquing on the opposite side
 - Black oxide

Options

- **Other versions are also available upon request:**
 - fine-ground threads
 - Left-hand thread
 - 2 twinned screws for increased unlocking torque
 - Other sizes
 - Other materials

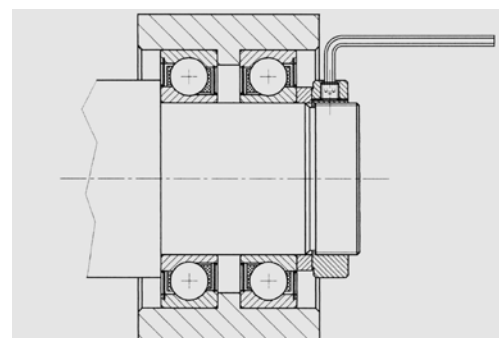

Exemple of application of one LRE Nut.

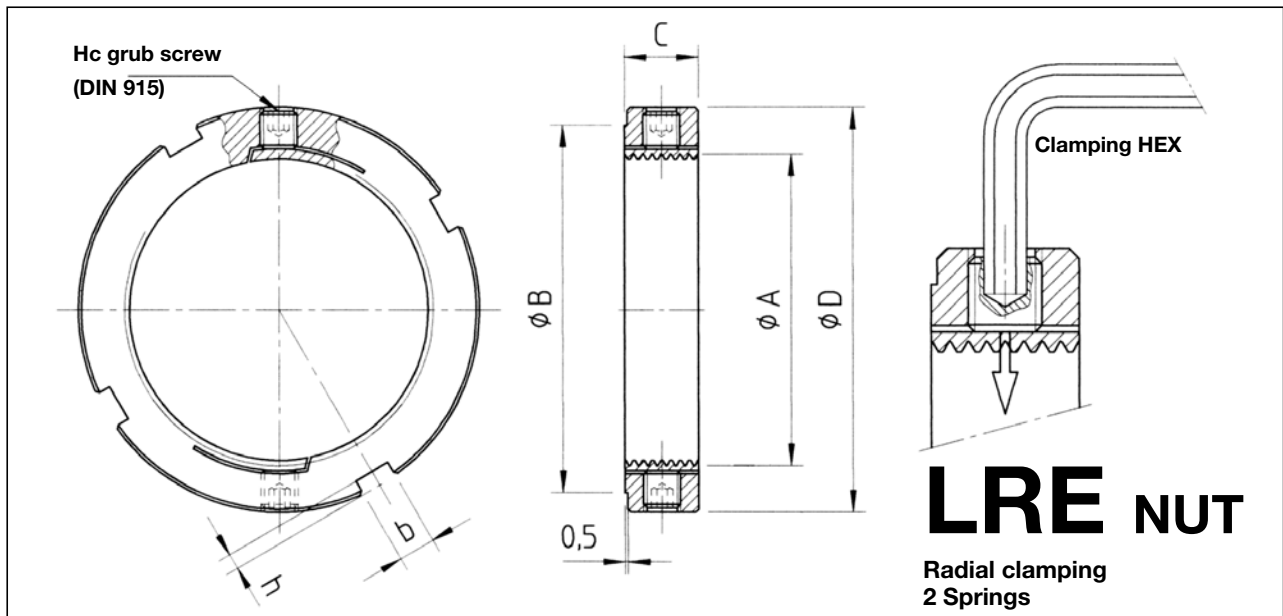

Type	Thread A	ø D	ø B	C	b x h	Hc grub screw	Unlocking Torque in Nm	Max Axial load in Newton	Weight in Kg
LRE 7	22 x 1.50	35	30		4 x 2		94	37 800	0,060
LRE 8	25 x 1.50	40	35				106	48 000	0,070
LRE 9	30 x 1.50	45	40				118	58 000	0,085
LRE 10	32 x 1.50	46	41		5 x 2		130	74 400	0,090
LRE 11	35 x 1.50	50	45			2 grub screws	150	77 700	0,095
LRE 12	38 x 1.50	52	47	12		M 6	166	82 000	0,100
LRE 13	40 x 1.50	55	49				188	85 200	0,100
LRE 14	42 x 1.50	56	50				210	89 600	0,110
LRE 15	45 x 1.50	60	54		6 x 2,5		236	100 000	0,120
LRE 16	50 x 1.50	65	59				264	115 600	0,130
LRE 17	52 x 1.50	67	61				294	120 400	0,130
LRE 18	55 x 2.00	75	68				1024	144 800	0,23
LRE 19	60 x 2.00	80	73		7 x 3		1064	158 300	0,25
LRE 20	65 x 2.00	85	78				1120	178 100	0,27
LRE 21	70 x 2.00	90	82				1174	192 100	0,28
LRE 22	75 x 2.00	95	87		8 x 3,5		1230	209 000	0,30
LRE 23	80 x 2.00	105	97				1300	228 000	0,42
LRE 24	85 x 2.00	110	102			2 grub screws	1350	245 800	0,44
LRE 25	90 x 2.00	115	106			M 8	1426	265 800	0,46
LRE 26	95 x 2.00	120	111	15	10 x 4		1500	280 800	0,49
LRE 27	100 x 2.00	125	116				1580	295 800	0,51
LRE 28	105 x 2.00	130	119				1660	310 800	0,52
LRE 29	110 x 2.00	135	124				1740	325 700	0,55
LRE 30	115 x 2.00	140	129		12 x 5		1860	345 200	0,57
LRE 31	120 x 2.00	145	134				1920	362 800	0,59
LRE 32	125 x 2.00	150	139				2080	383 000	0,62
LRE 33	130 x 2.00	155	144				> 4000	406 200	0,65
LRE 34	135 x 2.00	165	152			2 grub screws	> 4000	633 000	1,10
LRE 35	140 x 2.00	170	157	20	14 x 6	M 10	> 4000	660 800	1,13
LRE 36	145 x 2.00	175	162				> 4000	684 600	1,15
LRE 37	150 x 2.00	180	167				> 4000	712 900	1,20

***Values obtained with Hc grub screws:**

- M 6 screw - clamping torque 8 Nm
- M 8 screw - clamping torque 18 Nm
- M10 screw - clamping torque 36 Nm





LF NUT

1 Clamping spring front locking

Characteristics

- LF nuts are used wherever a strong radial clamping is not possible.
- The axial strength activated by turning the front Hc grub screw is applied onto the threaded clamping spring through 90° wedges.
- The resulting radial strength applies onto the clamping spring. The clamping pressure applied onto the threaded surface of the spring allows for a powerful locking.
- The contact surface perpendicular to the threaded side allows the adjusting and securing of all types of bearings as well as other mechanical elements requiring very precise tolerances.
- In addition to the notches, the holes located on the front side allow an easy positioning of the nut by mean of a spanner wrench.

Specifications

- **Material:** High elastic limit steel
- **Peripheral notches:** 4 at 90°
-   To ensure squareness and minimum run-out of the nuts and rings, all threading and contact face machining operations are performed in one setting.
- **Screw:** Hc type set-screw with cone tip 14.9
- **Standard manufacturing:**
 - 4H class precision threading
 - right-hand thread
 - Fine-ground contact face
 - Marquing on the opposite side
 - Black oxide

Options

- **Other versions are also available upon request:**
 - fine-ground threads
 - Left-hand thread
 - Other sizes
 - Other materials

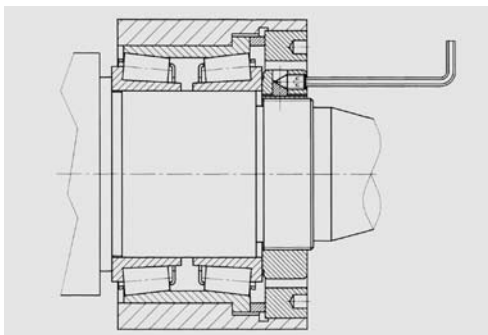

Set up of taper roller bearing onto a drill press spindle.

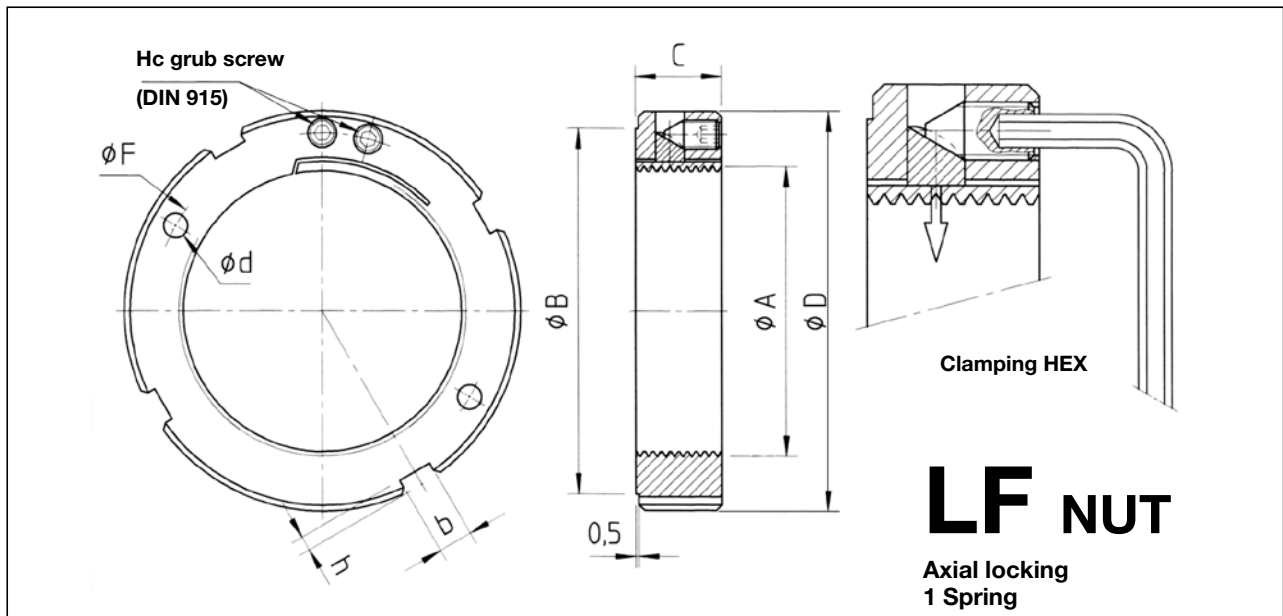

Type	Thread A	Ø D	Ø B	C	b x h	Ø F	Ø d	Hc grub screw	Unlocking Torque in Nm*	Max Axial load in Newton	Weight in Kg
LF 1	12 x 1.00	28	22			20		1	4	36 200	0,050
LF 2	14 x 1.00	30	25			22		grub screw	6	42 600	0,055
LF 3	15 x 1.00	31	26			23		M 4	6	51 500	0,060
LF 4	17 x 1.00	33	28		4 x 2	26	3,2		7	58 700	0,065
LF 5	18 x 1.00	34	29			26		2	9	55 400	0,070
LF 6	20 x 1.00	37	32			29		grub screws	10	61 800	0,080
LF 7	22 x 1.50	39	34			30		M 4	12	64 700	0,090
LF 8	25 x 1.50	43	38			33			15	80 200	0,100
LF 9	30 x 1.50	48	43			39			20	100 600	0,120
LF 10	32 x 1.50	50	45	15	5 x 2	41			24	113 500	0,125
LF 11	35 x 1.50	53	48			44			29	118 500	0,140
LF 12	38 x 1.50	56	51			47			35	124 500	0,145
LF 13	40 x 1.50	58	52			50			41	127 100	0,150
LF 14	42 x 1.50	62	56			52		2	45	131 300	0,175
LF 15	45 x 1.50	65	59		6 x 2,5	55	4,2	grub screws	55	143 400	0,185
LF 16	50 x 1.50	69	63			59		M 5	70	165 200	0,190
LF 17	52 x 1.50	72	66			62			85	171 900	0,215
LF 18	55 x 2.00	75	68			65			105	241 300	0,23
LF 19	60 x 2.00	80	73		7 x 3	72			130	263 800	0,33
LF 20	65 x 2.00	85	78			76			160	291 000	0,35
LF 21	70 x 2.00	90	82			81			200	313 900	0,36
LF 22	75 x 2.00	95	87		8 x 3,5	86			220	347 800	0,39
LF 23	80 x 2.00	105	97			93			240	371 300	0,55
LF 24	85 x 2.00	110	102			98			250	394 900	0,57
LF 25	90 x 2.00	115	106			104			265	422 500	0,60
LF 26	95 x 2.00	120	111	20	10 x 4	107			295	446 300	0,63
LF 27	100 x 2.00	125	116			114		2	325	470 200	0,65
LF 28	105 x 2.00	130	119			118	5,2	grub screws	365	494 000	0,68
LF 29	110 x 2.00	135	124			122		M 6	405	517 800	0,72
LF 30	115 x 2.00	140	129		12 x 5	127			450	545 000	0,75
LF 31	120 x 2.00	145	134			132			500	574 300	0,78
LF 32	125 x 2.00	150	139			137			560	598 500	0,80
LF 33	130 x 2.00	155	144			142			635	626 600	0,85
LF 34	135 x 2.00	165	152			150		2	680	723 300	1,15
LF 35	140 x 2.00	170	157	22	14 x 6	155	6,2	grub screws	1065	761 900	1,20
LF 36	145 x 2.00	175	162			160		M 8	1065	789 300	1,25
LF 37	150 x 2.00	180	167			165			1065	821 700	1,30

*Values obtained with Hc grub screws:

- M 4 screw - clamping torque 2,5 Nm
- M 5 screw - clamping torque 5 Nm
- M 6 screw - clamping torque 8 Nm
- M 8 screw - clamping torque 18 Nm



LFE NUT

2 Symmetrical clamping springs balanced front locking

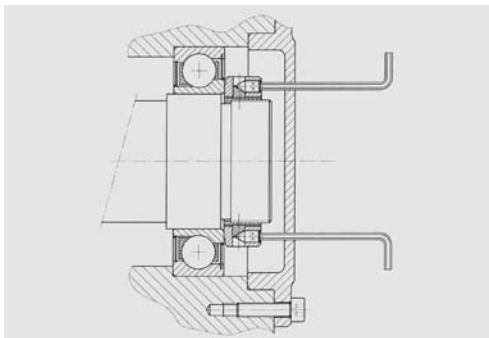

Characteristics

- LFE nuts are used wherever radial clamping is not possible. They are therefore highly recommended for securing parts inside housings or deep chambers as well as for mounting bearings inside such places.
- Featuring 2 symmetrical opposed clamping springs at 180°, these nuts have two advantages when compared to LF nuts:
 - Increased balance allowing higher rotation speeds
 - Twice as much locking power for the same size
- The axial strength activated by turning the 2 Hc grub screws is exercised onto the threaded spring through 90° wedges.
- The resulting radial strength applies onto the threaded spring. The clamping pressure applied onto the threaded surface of the spring allows for a powerful locking.
- The contact surface perpendicular to the threaded side allows the adjusting and clamping of all types of bearings as well as other mechanical elements requiring very precise tolerances.
- In addition to the notches, the holes located on the front side allow an easy positioning of the nut by mean of a spanner wrench.



LRP nuts for mounting and set up of a ball screw

Specifications

- **Material:** High elastic limit steel
- **Peripheral notches:** 4 at 90°
-  
 - To ensure squareness and minimum run-out of the nuts and rings, all threading and contact face machining operations are performed in one setting.
- **Screw:** Hc type with dog-point tip 14.9
- **Standard manufacturing:**
 - **4H** class precision threading
 - right-hand thread
 - Fine-ground contact face
 - Marquing on the opposite side
 - Black oxide

Options

- **Other versions are also available upon request:**
 - fine-ground threads
 - Left-hand thread
 - Other sizes
 - Other materials

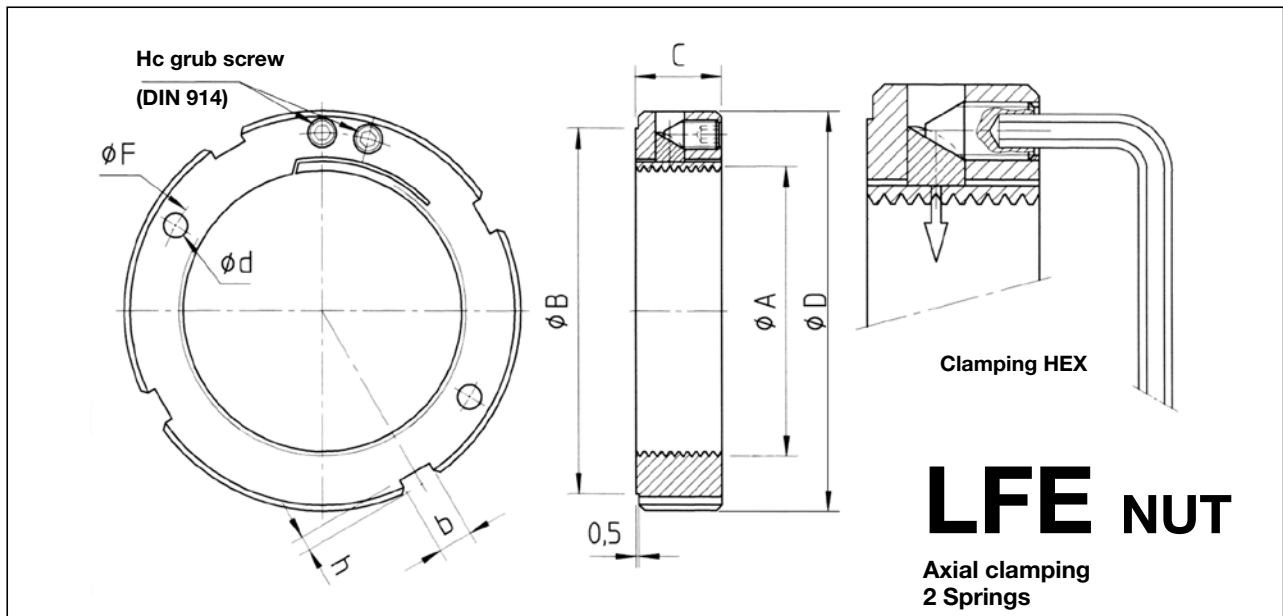

Type	Thread A	ϕD	ϕB	C	b x h	ϕF	ϕd	Hc grub screw	Unlocking Torque in Nm*	Max Axial load in Newton	Weight in Kg
LFE 7	22 x 1.50	39	34		4 x 2	30	3,2	4 x M 4	24	37 800	0,090
LFE 8	25 x 1.50	43	38			33			30	49 400	0,100
LFE 9	30 x 1.50	48	43			39			40	67 100	0,120
LFE 10	32 x 1.50	50	45	15	5 x 2	41			48	83 600	0,125
LFE 11	35 x 1.50	53	48			44			58	87 400	0,140
LFE 12	38 x 1.50	56	51			47			70	91 700	0,145
LFE 13	40 x 1.50	58	52			50			82	96 500	0,150
LFE 14	42 x 1.50	62	56			52		4	90	96 800	0,175
LFE 15	45 x 1.50	65	59		6 x 2,5	55	4,2	grub screws	110	108 800	0,185
LFE 16	50 x 1.50	69	63			59		M 5	140	132 200	0,190
LFE 17	52 x 1.50	72	66			62			170	137 600	0,215
LFE 18	55 x 2.00	75	68			65			210	193 000	0,23
LFE 19	60 x 2.00	80	73		7 x 3	72			260	211 000	0,33
LFE 20	65 x 2.00	85	78			76			320	238 600	0,35
LFE 21	70 x 2.00	90	82			81			400	257 300	0,36
LFE 22	75 x 2.00	95	87		8 x 3,5	86			440	298 100	0,39
LFE 23	80 x 2.00	105	97			93			480	318 300	0,55
LFE 24	85 x 2.00	110	102			98			500	338 600	0,57
LFE 25	90 x 2.00	115	107			104			530	366 700	0,60
LFE 26	95 x 2.00	120	111	20	10 x 4	107			590	387 400	0,63
LFE 27	100 x 2.00	125	117			114		4	650	408 100	0,65
LFE 28	105 x 2.00	130	119			118	5,2	grub screws	730	428 800	0,68
LFE 29	110 x 2.00	135	124			122		M 6	810	449 500	0,72
LFE 30	115 x 2.00	140	129		12 x 5	127			900	476 900	0,75
LFE 31	120 x 2.00	145	134			132			1000	508 600	0,78
LFE 32	125 x 2.00	150	139			137			1120	530 000	0,80
LFE 33	130 x 2.00	155	144			142			1270	559 200	0,85
LFE 34	135 x 2.00	165	152			150		4	1359	645 400	1,15
LFE 35	140 x 2.00	170	157	22	14 x 6	155	6,2	grub screws	2130	692 600	1,20
LFE 36	145 x 2.00	175	162			160		M 8	2130	717 600	1,25
LFE 37	150 x 2.00	180	167			165			2130	752 500	1,30

***Values obtained with Hc grub screws:**
 - M 4 screw - clamping torque 2,5 Nm
 - M 5 screw - clamping torque 5 Nm
 - M 6 screw - clamping torque 8 Nm
 - M 8 screw - clamping torque 18 Nm

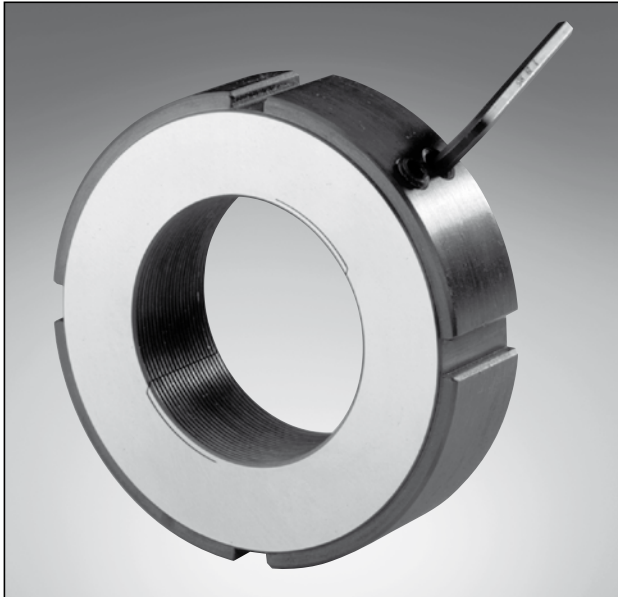

LRP NUT

2 Symetrical clamping springs radial locking heavy duty series

Characteristics

- LRP nuts are used wherever heavy duty clamping for ball bearings is required.
- Larger nuts, symetrical clamping springs and bigger screws ensure an increased unlocking torque as well as a much stronger resistance to axial load stress.
- The contact surface perpendicular to the threaded side allows the adjusting and securing of all types of bearings as well as other mechanical elements requiring very precise tolerances.

Specifications

- **Material:** High elastic limit steel
- **Peripheral notches:** 4 at 90°
- 
 - To ensure squareness and minimum run-out of the nuts and rings, all threading and contact face machining operations are performed in one setting.
- **Screw:** Hc type with dog-point tip 14.9
- **Standard manufacturing:**
 - **4H** class precision threading
 - right-hand thread
 - Fine-ground contact face
 - Marquing on the opposite side
 - Black oxide

Options

- **Other versions are also available upon request:**
 - Fine-ground threads
 - Left-hand thread
 - Other sizes
 - Other materials

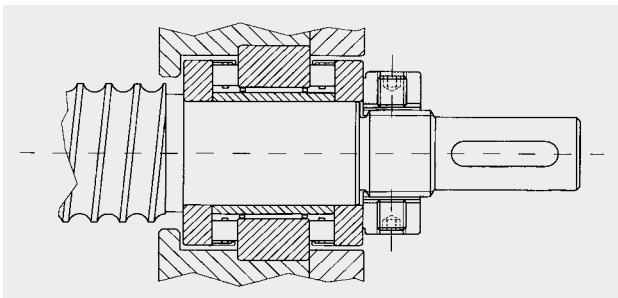

LRP nuts for mounting and set up of a ball screw

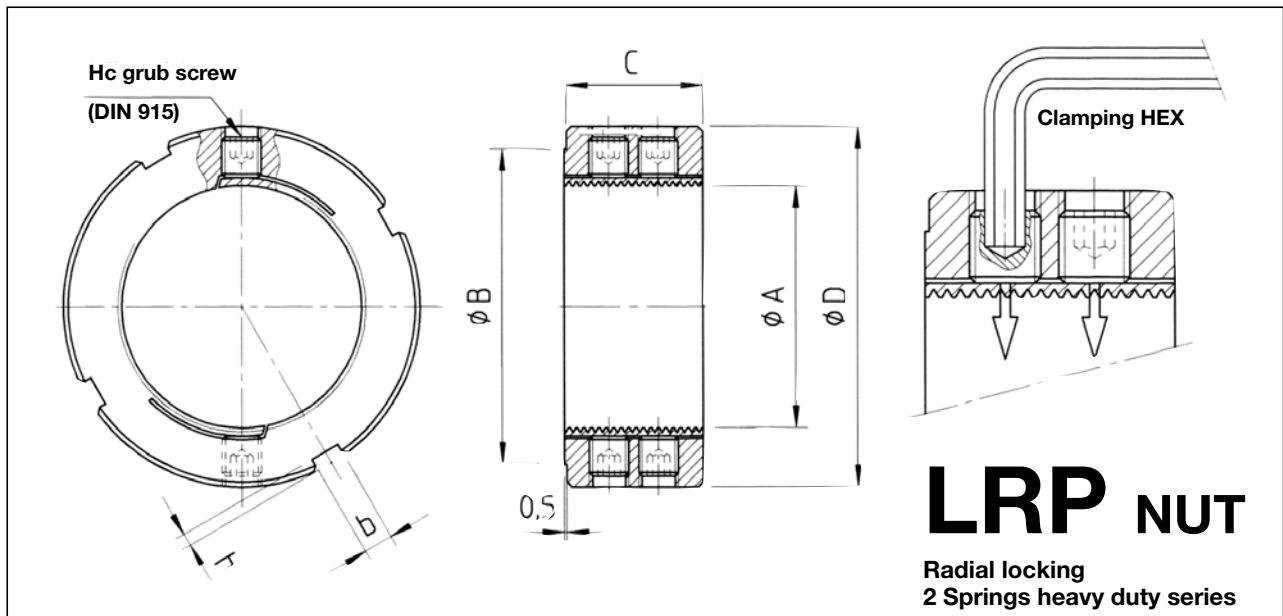

LRP NUT

Radial locking
2 Springs heavy duty series

Type	Thread A	Ø D	Ø B	C	b x h	HC Grub screw	Unlocking Torque in Nm	Max Axial load in Newton	Weight in Kg
LRP 20.150	20 x 1.50	42	37				155	48 861	0,130
LRP 22.150	22 x 1.50	44	39				180	56 997	0,140
LRP 25.150	25 x 1.50	47	42				210	68 558	0,150
LRP 30.150	30 x 1.50	52	47		5 x 2		235	91 109	0,170
LRP 32.150	32 x 1.50	55	50	16		2 screws	260	101 813	0,190
LRP 35.150	35 x 1.50	60	55			M 8	300	116 513	0,225
LRP 38.150	38 x 1.50	62	57				330	126 786	0,227
LRP 40.150	40 x 1.50	65	59				375	139 203	0,250
LRP 42.150	42 x 1.50	68	62		6 x 2,5		420	146 337	0,270
LRP 45.150	45 x 1.50	70	64				470	163 319	0,272
LRP 50.150	50 x 1.50	72	66				1200	290 849	0,446
LRP 55.150	55 x 1.50	78	71				1530	327 796	0,510
LRP 55.200	55 x 2.00	78	71				1550	297 488	0,515
LRP 60.150	60 x 1.50	83	76		7 x 3		1590	358 134	0,547
LRP 60.200	60 x 2.00	83	76				1600	330 268	0,553
LRP 65.150	65 x 1.50	88	81	28		4 screws	1680	402 859	0,585
LRP 65.200	65 x 2.00	88	81			M 8	1690	358 400	0,592
LRP 70.150	70 x 1.50	96	88				1760	440 525	0,715
LRP 70.200	70 x 2.00	96	88				1770	407 345	0,722
LRP 75.150	75 x 1.50	104	96		8 x 3,5		1840	482 416	0,857
LRP 75.200	75 x 2.00	104	96				1850	446 561	0,865
LRP 80.200	80 x 2.00	110	102				2500	558 080	1,084
LRP 85.200	85 x 2.00	115	107				2700	606 075	1,141
LRP 90.150	90 x 1.50	120	111				2850	666 863	1,188
LRP 90.200	90 x 2.00	120	111		10 x 4		2860	651 140	1,198
LRP 95.200	95 x 2.00	125	116				3000	687 844	1,255
LRP 100.200	100 x 2.00	130	121				3150	734 407	1,313
LRP 105.200	105 x 2.00	135	124				3320	776 789	1,370
LRP 110.200	110 x 2.00	138	127				3480	825 099	1,326
LRP 115.200	115 x 2.00	145	134		12 x 5		3720	868 730	1,485
LRP 120.200	120 x 2.00	148	137				3840	912 861	1,434
LRP 125.200	125 x 2.00	155	144			4 screws	> 4000	957 491	1,600
LRP 130.200	130 x 2.00	158	147	32		M 10	> 4000	1 002 620	1,541
LRP 135.200	135 x 2.00	165	152				> 4000	1 048 248	1,715
LRP 140.200	140 x 2.00	168	155				> 4000	1 087 450	1,649
LRP 145.200	145 x 2.00	175	162				> 4000	1 133 828	1,830
LRP 150.200	150 x 2.00	178	165				> 4000	1 180 705	1,756
LRP 155.300	155 x 3.00	185	172				> 4000	1 184 672	1,981
LRP 160.300	160 x 3.00	188	175		14 x 6		> 4000	1 231 267	1,900
LRP 165.300	165 x 3.00	195	182				> 4000	1 278 361	2,100
LRP 170.300	170 x 3.00	198	185				> 4000	1 325 955	2,010
LRP 180.300	180 x 3.00	210	197				> 4000	1 413 749	2,275
LRP 190.300	190 x 3.00	220	207				> 4000	1 493 151	2,390
LRP 200.300	200 x 3.00	230	217				> 4000	1 582 443	2,510



LX RING

1 Clamping spring External front locking

Characteristics

- LX rings feature the same principles as those of the LF nuts, applying the same to the bores and being consequently perfectly adapted for securing parts inside housings or chambers.
- The axial strength activated by turning the Hc grub screw is activated onto the threaded spring through 90° wedges.
- The resulting radial strength applies onto the threaded spring.
- The clamping pressure applied onto the threaded surface of the spring allows for a powerful locking.
- The contact surface perpendicular to the threaded side allows the adjusting and locking of all types of bearings as well as other mechanical elements requiring very precise tolerances.
- In addition to the notches, the holes located on the front side allow an easy positioning of the ring by mean of a spanner wrench.

Specifications

- **Material:** High elastic limit steel
- **Peripheral notches:** 4 at 90°
- 
 - To ensure squareness and minimum run-out of the nuts and rings, all threading and contact face machining operations are performed in one setting.
- **Screw:** Hc type set-screw with cone tip 14.9
- **Standard manufacturing:**
 - **4g** class precision threading
 - Fine ground threads
 - right-hand thread
 - Fine-ground contact face
 - Marquing on the opposite side
 - Black oxide

Options

- **Other versions are also available upon request:**
 - Left-hand thread
 - Additional clamping springs
 - Other sizes
 - Other materials

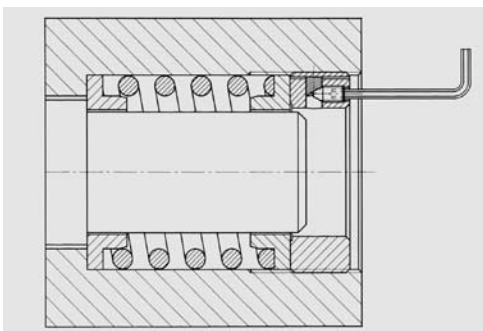

Pre-loading or relief setting of a spring-mounted device inside a housing.

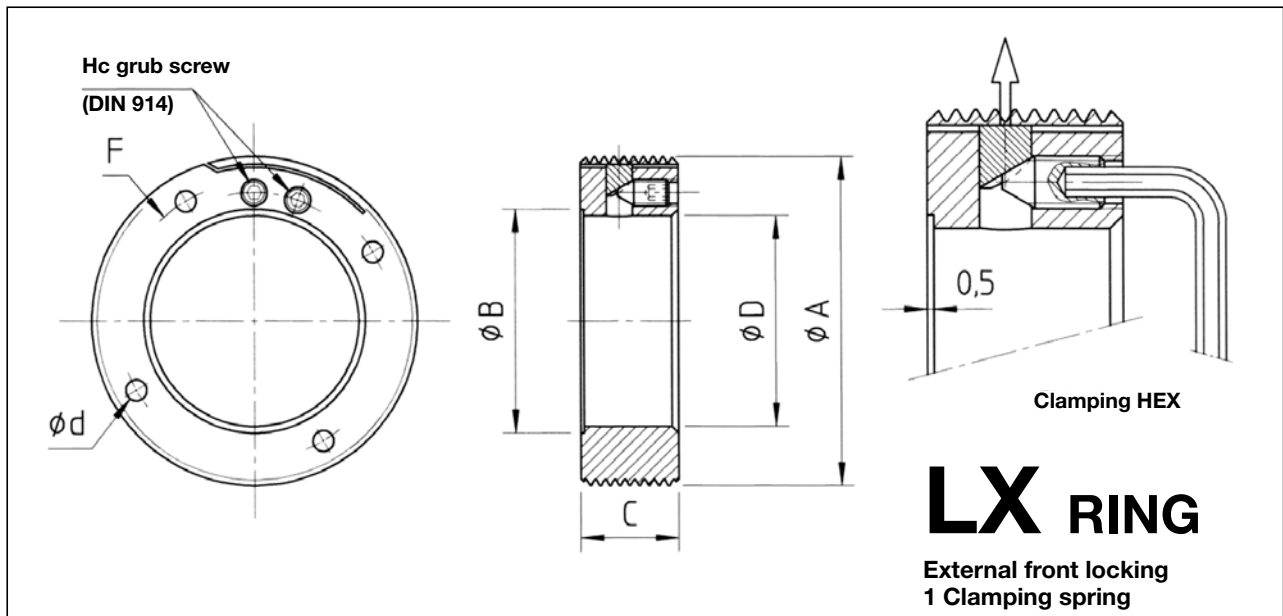

Type	Thread A	Ø D	Ø B	C	Ø d	Hc Grub screw	Max Axial load in Newton	Weight in Kg
LX 28	28 x 1.50	12	16				97 200	0,05
LX 30	30 x 1.50	14	20			1	104 400	0,06
LX 32	32 x 1.50	15	20			grub screw	119 500	0,06
LX 34	34 x 1.50	18	22			M 4	127 200	0,06
LX 37	37 x 1.50	20	26				138 800	0,06
LX 39	39 x 1.50	22	28				146 500	0,08
LX 40	40 x 1.50	23	29		3,2		152 800	0,08
LX 42	42 x 1.50	24	31				160 700	0,09
LX 44	44 x 1.50	26	32				168 500	0,09
LX 46	46 x 1.50	28	33	15		2	179 200	0,11
LX 47	47 x 1.50	29	34			grub screws	183 200	0,11
LX 49	49 x 1.50	31	34			M 4	188 100	0,10
LX 50	50 x 1.50	32	35				173 500	0,11
LX 54	54 x 1.50	36	40				187 700	0,15
LX 57	57 x 1.50	39	44				198 300	0,14
LX 60	60 x 1.50	42	50				208 900	0,14
LX 63	63 x 1.50	43	46				219 500	0,17
LX 64	64 x 1.50	44	46				223 000	0,18
LX 67	67 x 1.50	47	47				237 400	0,19
LX 70	70 x 1.50	48	48				248 200	0,21
LX 74	74 x 1.50	54	57				262 600	0,21
LX 77	77 x 1.50	55	64			2	275 000	0,33
LX 80	80 x 1.50	55	55		4,2	grub screws	384 800	0,37
LX 82	82 x 1.50	62	68			M 5	394 500	0,33
LX 87	87 x 1.50	67	76				421 400	0,34
LX 92	92 x 1.50	72	80				450 000	0,35
LX 97	97 x 1.50	77	85				474 700	0,37
LX 100	100 x 2.00	80	90				488 000	0,40
LX 102	102 x 2.00	82	91				497 900	0,42
LX 107	107 x 2.00	82	92				522 600	0,53
LX 112	112 x 2.00	87	100				547 300	0,55
LX 117	117 x 2.00	92	101	20			575 500	0,57
LX 122	122 x 2.00	97	107			2	602 200	0,60
LX 125	125 x 2.00	100	110			grub screws	620 800	0,62
LX 127	127 x 2.00	102	110		5,2	M 6	630 900	0,63
LX 132	132 x 2.00	107	116				661 800	0,66
LX 142	142 x 2.00	117	118				714 600	0,73
LX 147	147 x 2.00	122	133				740 000	0,74
LX 152	152 x 2.00	127	138				767 600	0,78
LX 160	160 x 2.00	135	145				808 400	0,83

Nadella

Milano

Via Melette, 16
20128 Milano

Tel. +39 02.27.093.297
Fax +39 02.25.51.768

<http://www.nadella.eu>

e-mail: customer.service@nadella.it

Nadella GmbH

Nufringen Rudolf-Diesel-Straße 28 Tel. +49 07032 95 40-0
71154 Nufringen Fax +49 07032 95 40-25
<http://www.nadella.eu> e-mail: info@nadella.de

AUSTRIA

TAT Technom Antriebstechnik GmbH

Haidbachstraße 1
4061 Pasching
Tel. +43 7229 648 400
Fax +43 7229 618 17
www.tat.at

CHINA

WENXIN Machinery

Guang Zhou Roa
Rm2001 20F JUNLIN Int. Plaza
Tel. +86 25 51 86 01 21
Fax +86 25 51 86 01 26
www.wenxinmachinery.com

CZECH REPUBLIC

TAT pohonova technika spol s.r.o.

Hranicni 53
37006 Ceske Budejovice
Tel. +420 387 414 414
Fax +420 387 414 415
www.tat.at/cz

DENMARK

ACTON A/S

Torbenfeldvej 3
2665 Vallensbaek
Tel. +45 43 73 70 43
Fax +45 86 75 27 00
www.acton.dk

FINLAND

EIE Maskin Oy

Postfach PL 80
10601 Tammisaari
Tel. +358 19 223 91 00
Fax +358 19 223 91 99
www.eie.se

FRANCE

SNR Lyon - Direction Réseau France

Le Florentin - B.P. 8
71, Chemin du Moulin Carron
Tel. +33 478 66 6800
Fax +33 478 66 6820
www.snr.bearings.fr

INDIA

NRB Bearings

Dhannur, 15 Sir P.M. Road, Fort,
Mumbai 400 001
Tel. +91 022 22 66 41 60
Fax +91 022 22 66 04 12
www.nrbbearings.com

KOREA

Intech Automation Inc.

Youngdeungpodong 7-GA
13FL, JEIL Bldg., 94-46
Seoul, Korea 150-037
Tel. +822 26 32 770
Fax +822 34 39 00 80
www.intechautomation.co.kr

NETHERLANDS

LinMotion BV

Kruisboog 2
3905 CV TG Veenendaal
Tel. +31 318 694 226
Fax +31 318 694 225
www.linmotion.nl

NORWAY

Elmeko AS

Postboks 80
1346 Gjetting
Tel. +47 675 72 270
Fax +47 675 77 280
www.eie.se

POLAND

ENITRA Sp.zo.o

ul. 1-go Maja 62 - 58300 Walbrzych
Tel. +48 74887 02 24 - Fax +48 74887 02 23
www.enitra.pl

SPAIN

GAES S.A.

Paseo Ubarburu, 58 Poligono 27
20014 - San Sebastian
Tel. +34 943 445 777 - Fax +34 943 445 350
www.gaessa.com

RODALSA S.L.

Barrachi, 12 - Pab. 21 - 01013 - Vitoria
Tel. +34 945 289 395 - Fax +34 945 289 246
www.rodalsa.net

SNR Rodamientos Iberica S.A.

Madrid C/Barberan, 6 - 28035 Madrid
Tel. +34 916 718 913 - Fax +34 916 736 548

SWEDEN

EIE Maskin AB

Harpseudswägen 197
12459 Bandhagen
Tel. +46 8 727 88 00 - Fax +46 8 727 88 99
www.eie.se

SWITZERLAND

Uiker Wälzlager AG

Schwerzistrasse 30 - 8807 Freienbach
Tel. +41 554 15 18 68
Fax +41 554 15 18 60
www.uiker.ch

TURKEY

EKSİM Mühendislik Sistemleri

Perpa Ticaret Merkezi B Blok Kat: 11 No: 1675
Sisli - Istanbul / Turkey
Tel. +90 212 222 81 12
Fax +90 212 222 81 02
www.eksimmuhendislik.com

