

Aerospace, Specialty and Industry Specific Bearings

Aerospace and specialty bearings are designed to meet unique aerospace and specialty industrial requirements. With over 75 years of bearing manufacturing experience and over 60 years of aerospace bearing experience, McGill bearings continue to set standards in the bearing world. Today, McGill is a key supplier to many major aerospace OEM's. Likewise, Rollway Bearings have been utilized in various industrial applications for the past century. Rollway has produced specialized bearings for demanding applications in a wide variety of industries.



World Class Quality

We can manufacture to meet a variety of specialty process and quality requirements. Our manufacturing facility has achieved Nadcap accreditation for our heat treating, chemical processing and nondestructive testing as well as AS9100 certification. To improve lead time and control quality, the majority of our heat treatment is done in our facility.



Integrated Engineering and Design Support from Start to Finish.

Our engineers and creative teams will work closely with you during every stage of the process to apply, design, engineer, and manufacture your highly customized bearings. McGill engineers run a comprehensive testing laboratory. Here our engineering teams perform virtual and physical testing. We are able to simulate a variety of aerospace applications, such as oil-out transmission conditions, de-icing chemical exposure and accelerated-life testing. McGill engineers also test and analyze the interaction of lubrication, surface finishes and contamination. We will help save you time and money if you involve our highly qualified engineers as early as possible in the design formation stage.



Bearing Types

- Cylindrical Roller
- Needle Roller
- Spherical Roller
- Precision Rollers
- Angular Contact, Gothic Arch & Radial Ball
- Aircraft Cam Followers & Track Rollers

Size and Precision

- Size Offering
12 - 300 mm O.D.
6 - 250 mm I.D.
- Roller Bearing Precision
RBEC 1,3,5
- Ball Precision
ABEC 1,3,5

Variety of Capabilities

- Flange Outer
- Gothic Arch
- Notches / Slots
- Riveted Retainers
- Multiple External Tabs
- Straight or Tapered Bore
- Geared Outer

Materials

- Standard Bearing Quality
- Specialty Steels
High Temperature
Corrosion Resistant



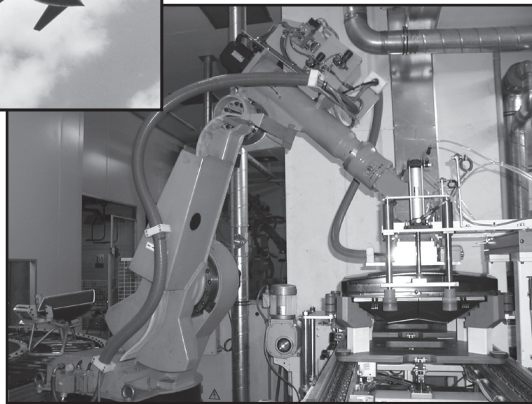

Applications

- Helicopter
 - Main gearboxes
 - Intermediate and tail-rotor gearboxes
 - Main rotors and tail-rotor
- Fixed-wing aircraft
 - Flaps and slats
 - Door mechanisms
- Other aerospace and military
 - Starters
 - Hydraulic systems
 - Control mechanisms
 - Weapons
 - Aircraft Carriers
 - Ground Vehicles
- Industrial
 - Rolling Mill equipment
 - Plastics and rubber extrusion equipment
 - Mining and construction equipment
 - Petrochemical processing equipment
 - Oil Field Equipment
 - Pumps and compressors
 - Material Handling
 - Can-making equipment
 - Medium to high speed gear boxes
 - Turbo machinery
 - Printing equipment
 - Paper converting equipment
 - Precision positioning equipment

Specifically for the commercial-passenger-jet industry, McGill has developed custom bearing solutions that include ball and roller bearings used for aircraft auxiliary pumps; thin-section, corrosion-resistant ball bearings in aircraft-control applications; and track rollers for flap and slat applications.

Within the helicopter industry, McGill has worked with customers to optimize load capability and weight for their specific applications. For instance, McGill has developed spherical roller planetary bearings for helicopter transmissions, and ball and roller bearings with different integral antirotation devices, such as flanges, slots and tabs.

McGill has produced a variety of specialty bearings for industrial applications as well as aerospace. Products range from modifications of standard industrial parts to completely new designs to fit specific applications. Common special features include extra precision, unique geometries and/or specialty materials.



Rollway Bearings for the Oil Field

Rollway Bearings has been a reliable component in the oil field industry for the past few decades. We have the unique capability to provide a wide variety of bearings ranging from large bore cylindrical radial bearings, tapered thrust bearings, complimented by McGill precision bearings for your replacement and re-build needs.

We manufacture a variety of styles of bearings for the following oil field applications:

- Mud pumps
- Top drives
- Crane hooks
- Swivels
- Draw works
- Frac pumps
- Cranes
- Winches

These are only a portion of the Oilfield applications we regularly provide bearings for.





Rollway Wheel Bearings for Off-Highway Vehicle Electric Wheels



GE* Motorized Wheels used In

- Unit Rig Trucks
- Liebherr* / Wiseda* Trucks
- Euclid* / Hitachi* Trucks
- Komatsu* Trucks

Rollway is committed to providing value to the mining industry by manufacturing the best value cylindrical roller bearings available. Whether you're looking to replace an armature bearing as a result of an inspection or all the motor bearings for a rebuild, Rollway is there providing high quality bearings, when you need them. The combination of reliable performance and availability will help your trucks maintain more "Uptime" which translates to more loads per day.

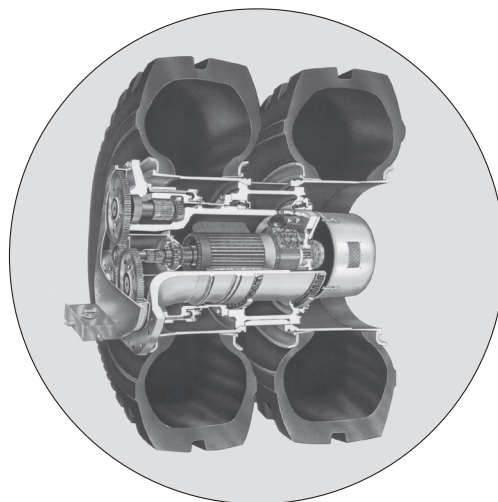

Rollway Number	GE Wheel Number GE Wheel Number	GE Part Number	Location
U-2934-LP-033	772	8864951P180	Planetary Gear
E-5019-U-103	772	8864951P114	Planetary Pinion
E-5019-U-105	772	8864950P111	Planetary Pinion
MUC-224-014	772, 776, 791	8864951P139	Pinion End Armature
E-5220-U-112	772, 776, 791	8864951P118	Planetary Pinion
E-5220-U-118	776, 791	8864951P297	Planetary Pinion
E-5040-U-103	787, 788	8864951P200	Planetary Pinion
E-5044-UMR-105	787, 788	8864951P206	Planetary Pinion
NU 1030 M1C3	787, 788, GDY85	8864951P163	Pinion End Armature

In recognition of proven performance, Rollway is an approved supplier of GE* motorized wheel bearings.

* The following trade names, trademarks and/or registered trademarks are used in this material by Regal Power Transmission Solutions are NOT owned or controlled by Regal Power Transmission Solutions and are believed to be owned by the following parties: Euclid: Euclid-Hitachi Heavy Equipment, Inc.; GE: General Electric Company; Hitachi: Kabushiki Kaisha Hitachi Seisakusho dba Hitachi, Ltd.; Komatsu: Kabushiki Kaisha Komatsu Seisakusho aka Komatsu Ltd.; Liebherr: Liebherr International AG; Wiseda: Liebherr Mining Truck, Inc. Regal Power Transmission Solutions cannot and does not represent or warrant the accuracy of this information.