



Cylindrical Roller Bearings for Multi-roll Mill Backup Rolls



JTEKT started producing cylindrical roller bearings for backup rolls for Sendzimir mills in the 1950s and has continued to provide superior products for customers around the world.

As regards to the backup rolls assembling products, which is the Key component of the Sendzimir mill, we concluded a production agreement for licensing with SENDZIMIR JAPAN, LTD. in 1970 and now supply over 100 products for Sendzimir mills around the world.

We support our customer's operations stability not only with cylindrical roller bearings for backup rolls, but with cylindrical roller thrust bearings for work rolls , bearing-regrinding jigs, measurement of the bearing's section height with equipment developed at JTEKT and our technical know-how and experience.

JTEKT has a long history of providing high quality products and the experience to offer products with high durability and reliability.



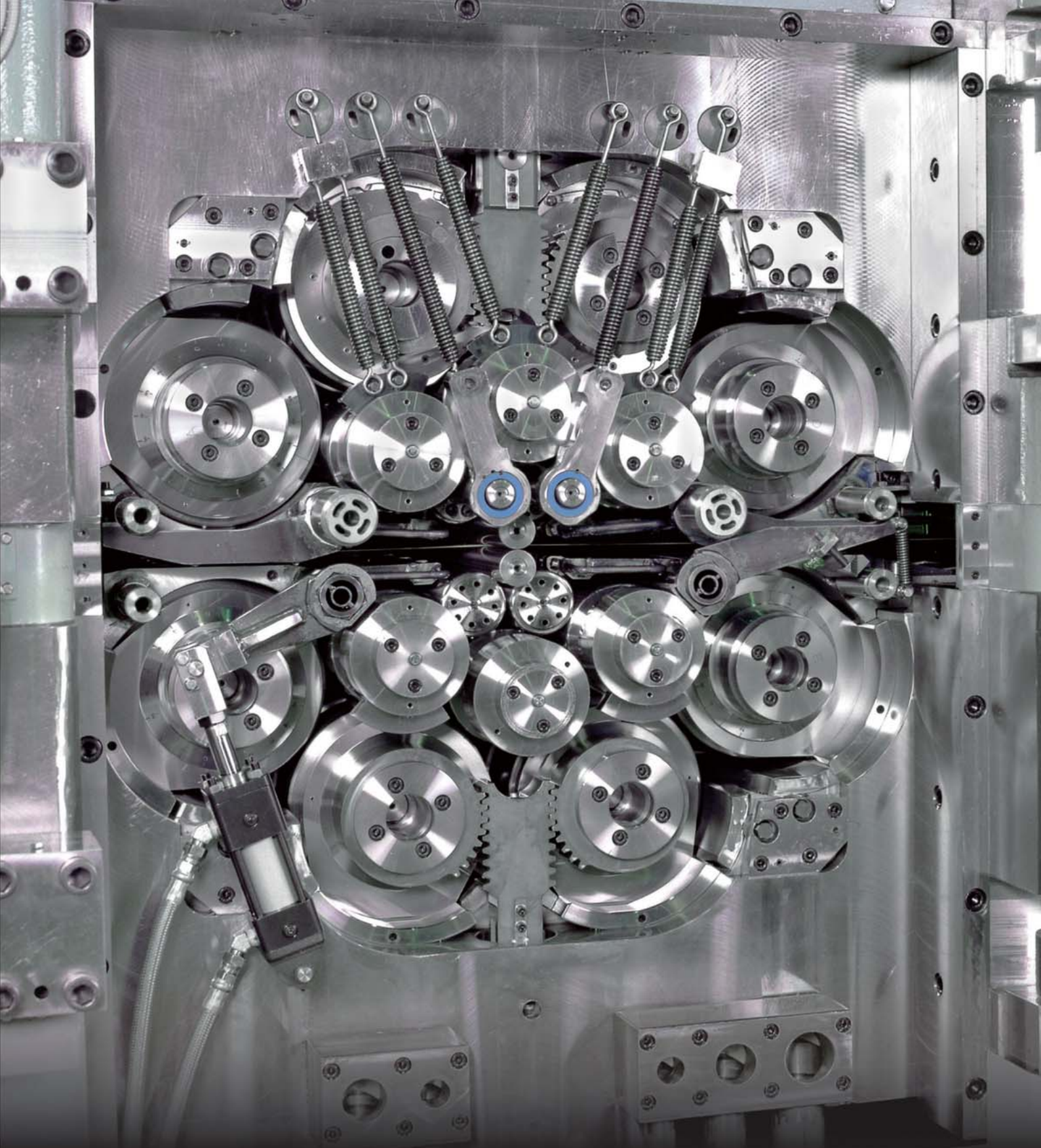

Multi-roll mills enable our customers to utilize extremely small diameter work rolls with a choice of 12 or 20 rolls. Thereby, we are now capable of rolling hard materials such as stainless steel sheets and electrical steel sheets as well as rolling ultrathin copper. Cylindrical roller bearings for backup rolls play a significant role in obtaining this high level of efficiency.

Cylindrical roller bearings for multi-roll mill backup rolls

JTEKT has provided Cylindrical roller bearings for backup rolls with high durability and precision, contributing to the utmost performance in multi-roll mills.



Required performance and issues

- Seal structure that maintains a favorable lubricated state
- Longer inner ring rolling fatigue service life
- Improving outer ring durability
- Improving outer ring rotational accuracy
- Improving ease of outer ring regrinding work (P15-16)

Bearing configuration and features

The bearings which are used for multi-roll mill backup rolls are attached to the rolls on 1 shaft and the bearings outer diameter are fit closely to the intermediate roll which rotates while loading the rolling component force. Therefore, the outer ring must be fabricated having sufficient rigidity and fatigue strength as well as high precision. At JTEKT, we assemble the bearings in a specially controlled clean working environment.

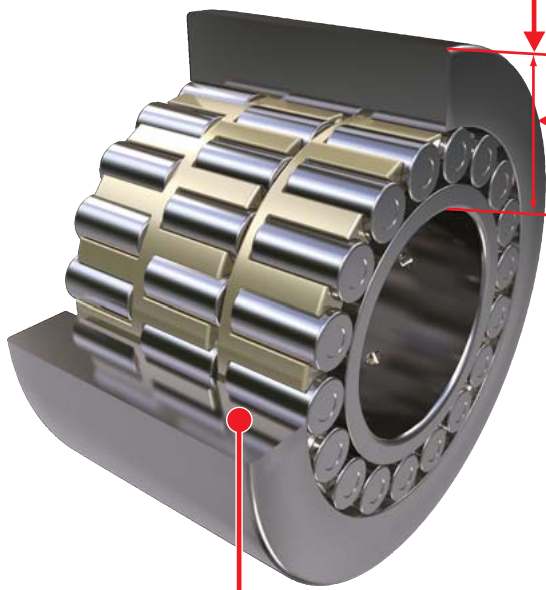

- The outer surface of the bearing is manufactured through crowning, which accounts for the contact stress distribution to prevent damage to the intermediate roll due to edge load.

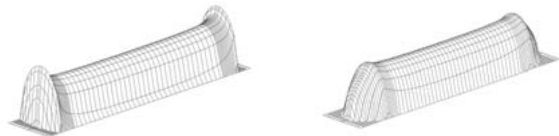

Uncrowned outside surface Crowned outside surface
 Typical contact stress distribution of the outer-ring's outside surface
 (Refer to P16 for the dimensions of the outer ring crowning)

- By ensuring that high precision in both the variation of the bearing's section heights and high rotation accuracy is achieved for optimum distribution of the bearing loads and supporting the development in rolling precision and the quality of the coils.

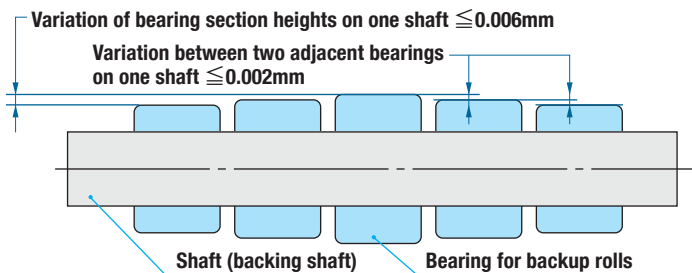

Cored hardening

- Outer ring is fabricated by JTEKT original developed steel and cored hardening.

※ Cored hardening is applied to bearings of over 130mm inner diameter.

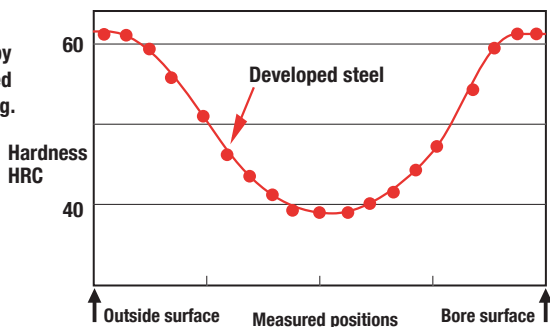

Typical hardness distribution of cored hardening outer ring

Surface-hardened layer improved approximately 3-fold

Surface-hardened layer



Approx. 3-fold



Long life, highly corrosion-resistant JHS is driving innovations in steel production equipment.

Iron manufacturing and rolling mill lines must operate continuously while maintaining high reliability in severe production environments. Answering these needs through the realization of epoch-making long-life and high corrosion resistance is JTEKT Hyper Strong (JHS). By adopting newly developed materials and processes for bearing steel, seal materials and other components, we have realized a 2-to-4-fold increase in bearing service life compared to previously used bearings. Continuing on from JHS520 for rolling mill roll necks and JHS210 for Sendzimir rolling mill backup rolls, we are steadily expanding the bearing series according to each application. The JHS bearing series offers total support for achieving maximum performance and durability in the ever-evolving field of steel equipment. Please keep your expectations high. We won't let you down.

- Seal structure that maintains a favorable lubricated state
- Improving outer ring durability
- Improving outer ring rotational accuracy

Bearing for oil mist lubrication

- Advantages**
- Improving bearing service life (2-fold/4-fold compared to conventional types)
 - High sealing performance
 - Oil seal's Space-saving size for simple installation/ removal

[Service life]

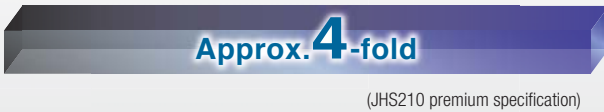

Premium specifications

JHS 210

Case-hardened steel is used for the inner ring to suppress the loss of rolling service life under low-viscosity lubrication. Bearing service life is approx. 4-fold compared to the conventional type.

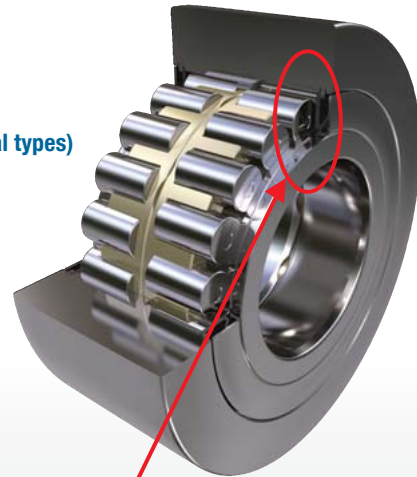

Use of snap ring simplifies oil-seal insertion/removal

Seal plate

Prevents intrusion of rolling mill water

Oil seal rotates together with outer ring

Centrifugal force of the seal lip section discharges rolling mill water that has infiltrated to the outside

- Longer inner ring rolling fatigue service life
- Improving outer ring durability
- Improving outer ring rotational accuracy

Bearing for forced oil lubrication

- Advantages**
- Outer ring with both high rigidity and durability realized
 - High resistance to fatigue realized owing to superior materials composition
 - Design optimized to match surrounding structure

[Service life]



Premium specifications

JHS 210

Case-hardened steel is used for the inner ring to suppress the loss of rolling service life under low-viscosity lubrication. Bearing service life is approx. 1.5-3-fold compared to the conventional type.

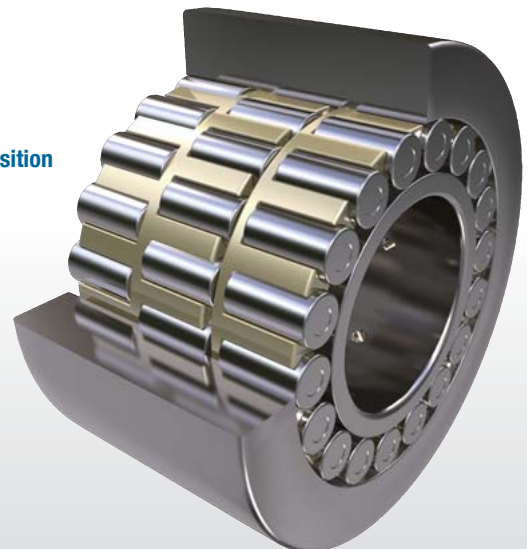

Bearing instruction

Here is an illustration of how we disassemble, assemble and inspect the bearings. Please follow this for bearing maintenance.

Bearing for oil mist lubrication

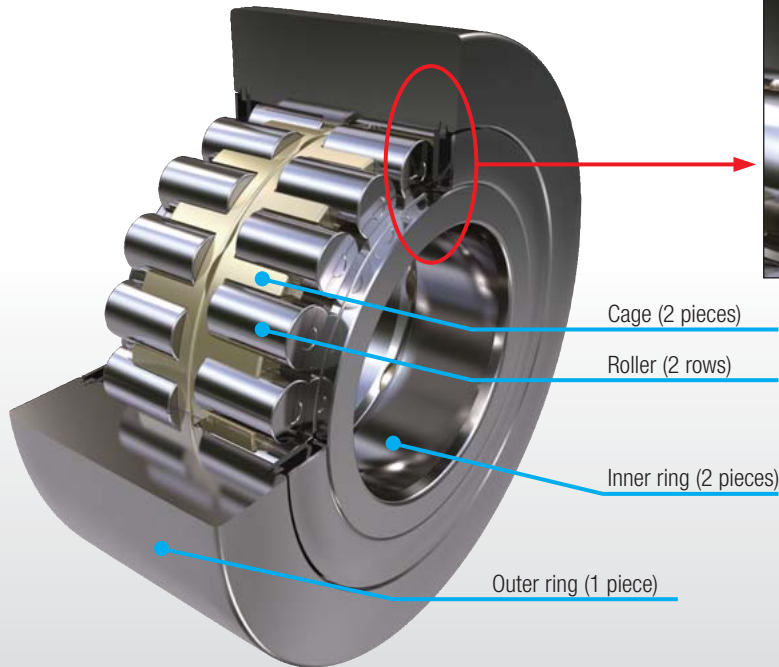

※ Please use 10-40kPa for oil mist manifold pressure.

Inner ring disassembling points

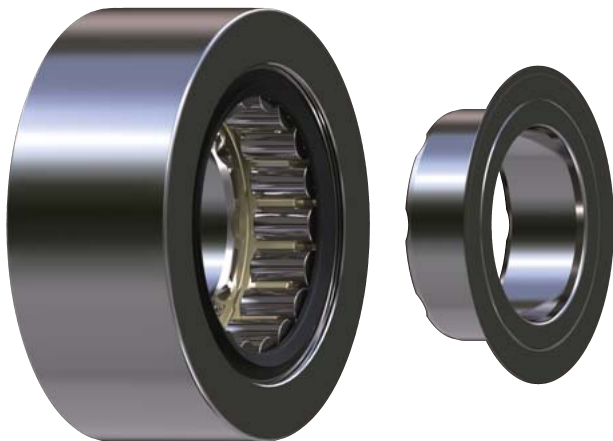

(1) Remove inner rings (both rings)

Seal plate will be removed with inner rings due to the press-fitting of the inner ring.

[!] Caution

Be careful when handling the seal plate. Any damage to seal plate may affect the performance of the bearing's sealing.

Inner ring inspection points

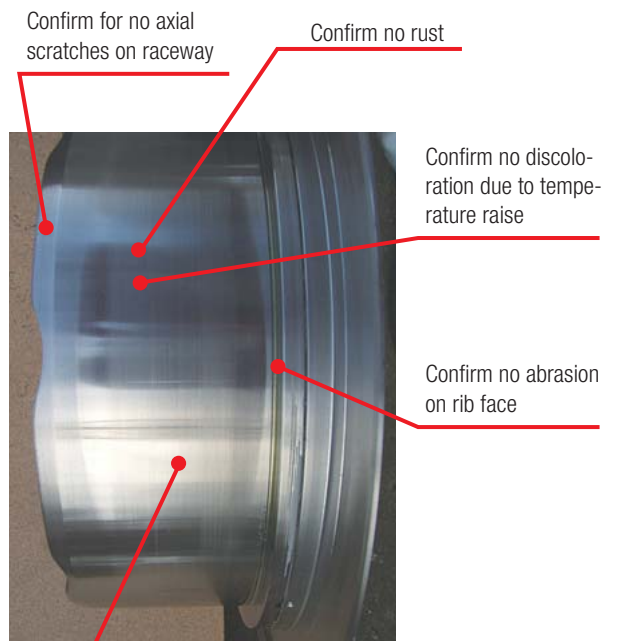

Confirm that race way has no unbalanced, asymmetrical roller contact marks on both rows.

Oil seal disassembling points

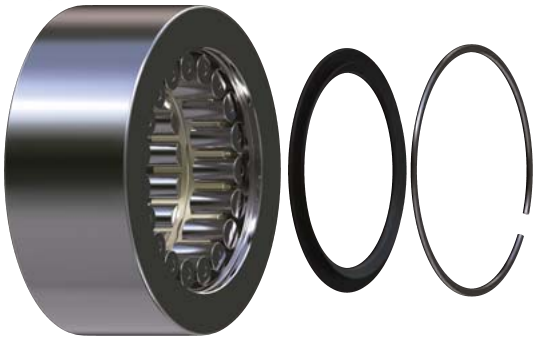

- (2) Remove snap ring (both pieces)
- (3) Remove oil seals (both pieces)

【!】Caution
Be careful to not scratch the oil seal when removing the snap ring and oil seal.

Oil seal inspection points



Confirm no cracking or chipping on seal lip part

【!】Caution
In case of cleaning the oil seal with cleaning oil, please wipe off the cleaning oil immediately.

Roller · Cage disassembling points



- (4) Hold the cage and remove it with the roller (both rows)

【!】Caution
Be sure to keep all rollers and other parts separate from other bearing parts and manage each bearing independently.

Roller inspection points

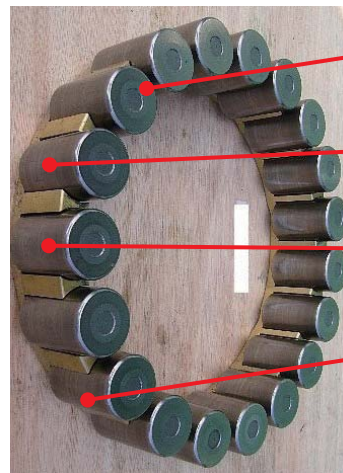

Confirm no abrasion

Confirm no discoloration due to temperature rise

Confirm no cracking or chipping

Confirm no rust

Outer ring inspection points



Confirm no cracking or chipping

Confirm no slipping scratches or brinelling



Confirm no discoloration due to temperature rise

Confirm no rust

Confirm that race way has no unbalanced, asymmetrical roller contact mark on both rows

Confirm no abrasion on rib face

Bearing instruction

Here is an illustration of how we disassemble, assemble and inspect the bearings. Please follow this for bearing maintenance.

Assembling cylindrical roller bearings for backup rolls

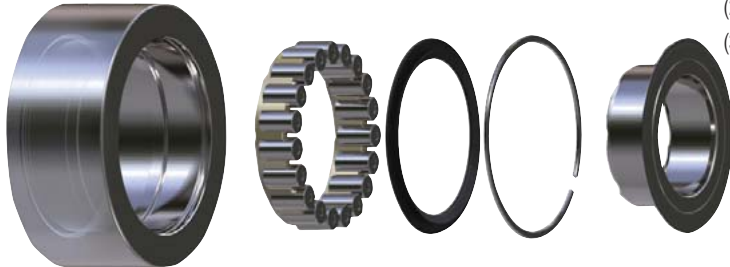

- (1) Complete cleaning of each part before re-assembling.
- (2) Assemble the bearings in the reverse order of disassembling.
- (3) Before inserting the inner ring (with seal plate), supply the initial lubricate oil (mist oil) into the bearing.

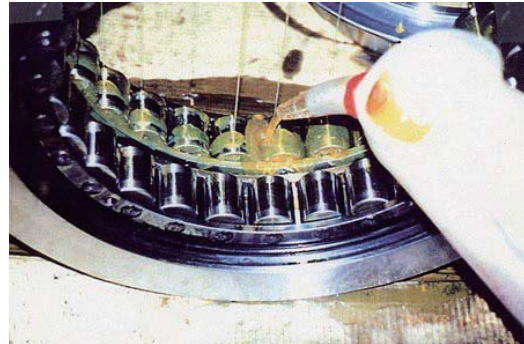

Caution

- Be careful to insert only appropriate bearing parts. There are no compatible parts with other products.
- During re-assembly, be careful not to contaminate the bearing with any foreign matter. Please handle with care so as not to scratch any surfaces of the bearing.

Bearings for forced oil lubrication

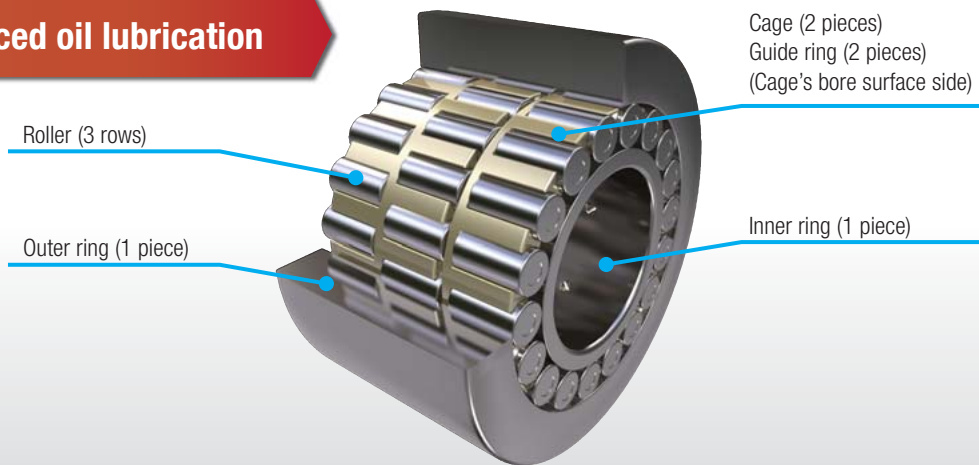

Inner ring disassembling points

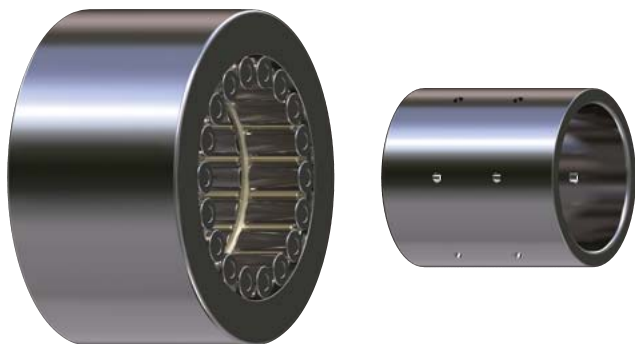

- (1) Remove inner ring (1 piece)

Inner ring inspection points

Confirm there are no axial scratches on the raceway

Confirm no discoloration due to temperature rise

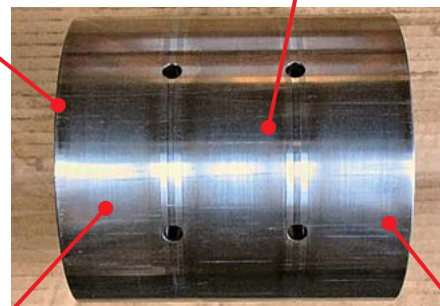

Confirm no rust

Confirm that race way has no unbalanced, asymmetrical roller contact mark on 3 rows

Roller · Cage disassembling points



(2) Hold the cage and remove it with roller (2 rows and 1 row)

【!】 Caution

Be sure to keep all rollers and other parts separate from other bearing parts and manage each bearing independently.

Roller inspection points

Confirm no cracking or chipping

Confirm no discoloration due to temperature rise

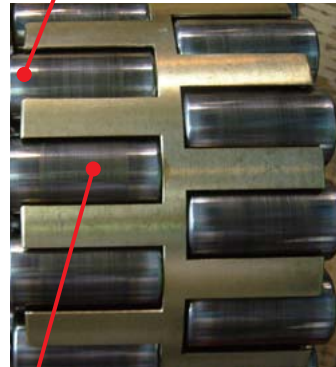

Confirm no rust

Confirm no abrasion

Outer ring inspection points

Confirm no cracking or chipping

Confirm no slipping scratches or brinelling

Confirm no rust

Confirm no discoloration due to temperature rise

Confirm that race way has no unbalanced, asymmetrical roller contact mark on 3 rows

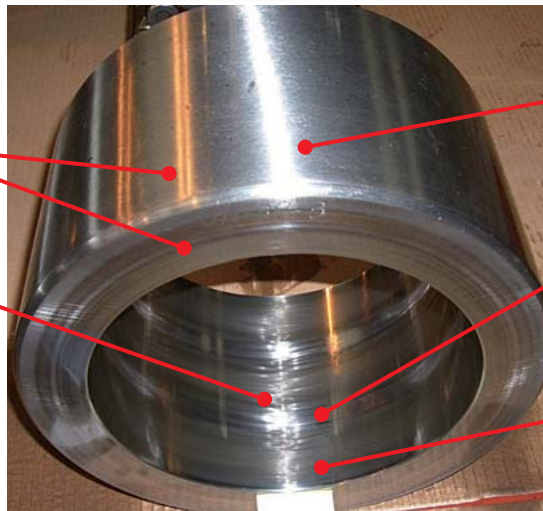

Assembling cylindrical roller bearings for backup rolls

(1) Complete cleaning of each part before re-assembling

(2) Assemble the bearings in the reverse order of disassembling

【!】 Caution

• Be careful to insert only appropriate bearing parts. There are no compatible parts with other products.

• During re-assembly, be careful not to contaminate the bearing with any foreign matter. Please handle with care so as not to scratch any surfaces of the bearing.

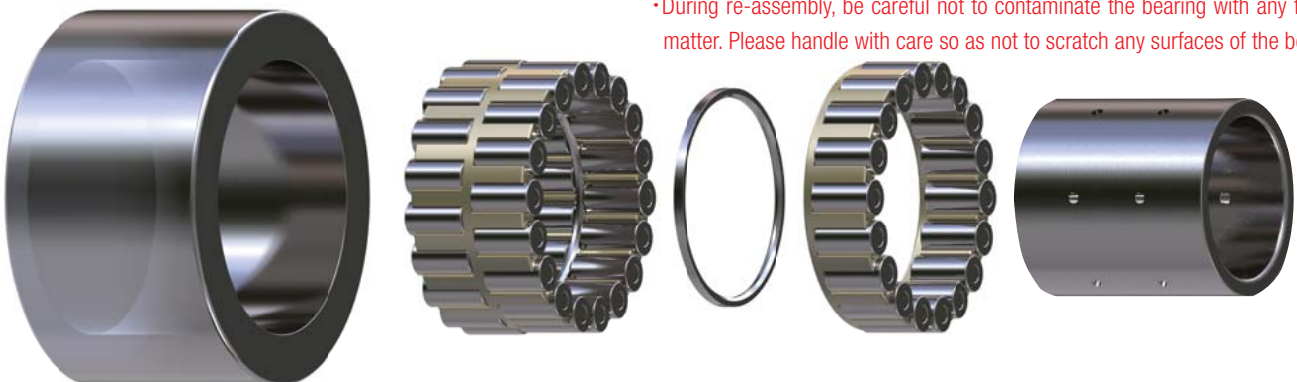

Examples of bearing failures and countermeasures

JTEKT's countermeasures for various failures. Please follow this bearing maintenance program for optimum performance.

Outside surface of outer ring's slipping scratches and grinding burn

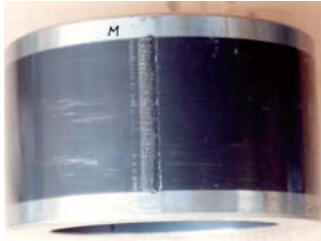

Outside of outer ring's slipping scratches

<Probable causes>

- Slip with the intermediate roll (Sheet jam, involution and so on)

<Countermeasures>

- Review operating conditions
- <Countermeasures>
- After removing the slipping scratches on outer surface of the outer ring, a minimum of 0.5mm re-grinding on outer ring diameter needs to be done.

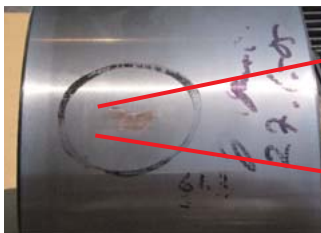

Outside of outer ring's grinding burn

<Probable causes>

- Improper regrinding of outer ring (Heavy grinding, lack of grinding fluid, clogged grinding stone, etc.)

<Countermeasures>

- Optimizing the grinding conditions, improving grinding stone
- <Countermeasures>
- dispose

Transcription mark on intermediate roll

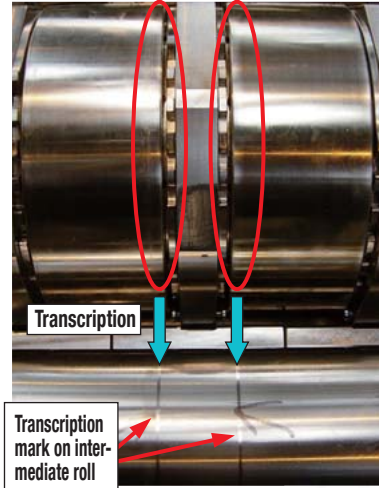

<Probable causes>

- Improper regrinding of outer ring (Clogged grinding stone) → rough outside surface (include scratches and foreign matter)
- occurrence of transcription mark on intermediate roll

<Countermeasures>

- Optimizing grinding conditions, improving grinding stone and cleaning outside surface and shaft
- <Countermeasures>
- Reusable by grinding outside surface
- Reusable by grinding intermediate roll

Outside of outer ring's slipping scratches

Expansion of crowning part on outer ring O.D.

Rough surface of outer ring O.D.

Brinelling on raceway

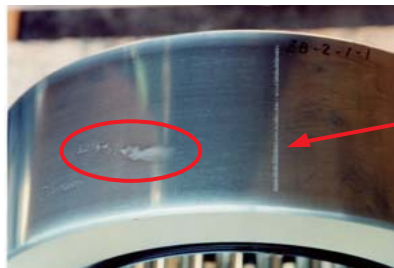

Brinelling on outer ring O.D.

Slipping scratches (see above)



Brinelling on raceway surface of outer ring

<Probable causes>

- Foreign matter jam (rolling material's fragmentation, etc.)

<Countermeasures>

- Rolling oil cleaning
- <Countermeasures>
- Reusable by regrinding outside surface. Reusable by lapping raceway surface. However, if damage is too severe, dispose

Raceway ring's cracking

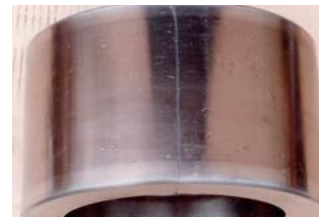

Outer ring cracking



<Probable causes>

- Outside surface damage progresses from slipping scratches.
- Side surface damage progresses from heat cracks (due to slipping with thrust washer.)

<Countermeasures>

- Remove the slipping scratch by regrinding the outer ring O.D.
- Proper management of thrust washers
- <Countermeasures>
- dispose



Inner ring cracking

<Probable causes>

- Excessive axial load due to misaligned roll or irregular section height of bearings in one shaft.

<Countermeasures>

- Restraining misaligned roll
- Control of section height of bearings in one shaft

<Countermeasures>

- dispose

Raceway · roller flaking

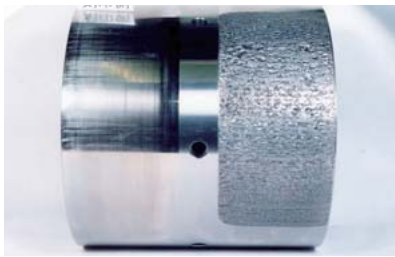

Raceway flaking



Roller flaking

<Probable causes>

- Rolling fatigue service life, excessive loading, improper lubrication

<Countermeasures>

- Review operating conditions
- Review viscosity of oil lubrication

<Countermeasures>

- dispose

However, in the case of minimal flaking of the inner ring, it's reusable by removing the flaking and setting in an unloading position

Rust · scratches

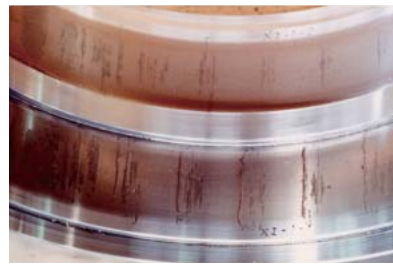

Rust

<Countermeasures>

- After use, disassemble and clean as soon as possible
- perform rust prevention maintenance
- confirm the seals condition

<Countermeasures>

- Reusable by lapping using oil grinding stone or sandpaper
- In case of severe condition, dispose

<Probable causes>

- After use, equipment has been left for a long period without disassembling
- Improper storage condition
- Intrusion of mill water

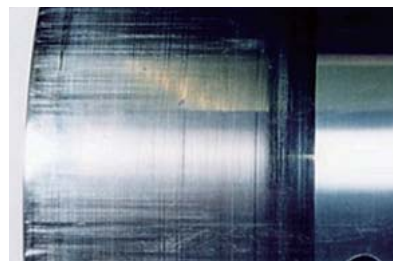

Scratches

<Countermeasures>

- Appropriate caution during bearing's disassembling and re-assembling

<Countermeasures>

- Reusable by lapping using oil grinding stone or sandpaper
- In case of severe condition, dispose

<Probable causes>

- Scratches during bearing's disassembling or re-assembling

Smearing or abrasions



Roller Smearing

<Probable causes>

- Minimal loading
- improper lubrication

<Countermeasures>

- proper loading
- review lubricant condition

<Countermeasures>

- Reusable by lapping using In case of severe condition, dispose (when picture's state, dispose)



Roller abrasion

<Probable causes>

- Bearing misalignment
- improper lubrication
- Foreign matter jam

<Countermeasures>

- Maintaining alignment of the bearing
- review lubricant condition

<Countermeasures>

- usually disposal

Raceway wear

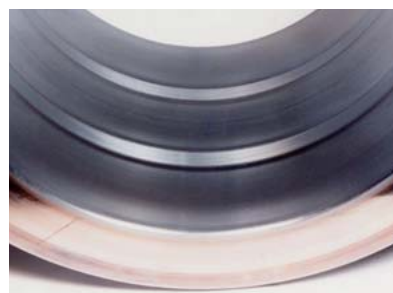

Raceway wear

<Countermeasures>

- proper loading
- review lubricant condition

<Countermeasures>

- Usually disposal

<Probable causes>

- Excessive loading
- improper lubrication



Fretting on bore surface of inner ring

<Countermeasures>

- (It is not possible to change the shaft and inner ring fit independently)
- Apply lubricant into the fitting surface of the shaft and inner ring Appropriate operating period

<Countermeasures>

- Reusable by lapping using oil grinding stone or sandpaper

<Probable causes>

- Loose fitting between shaft and inner ring

Bearing dimensions table

A list of available bearings can be found in the following dimensions table. For any dimensions which are not on the table, please consult JTEKT.

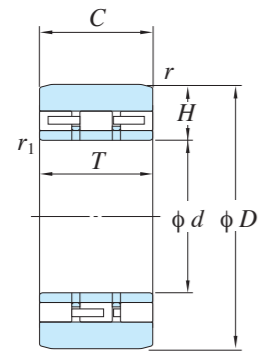

Design 1

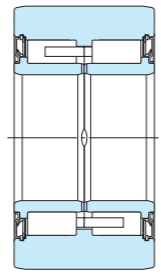

Design 2

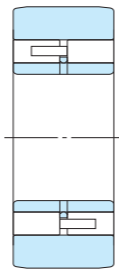

Design 3



Design 4

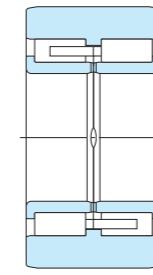

Design 5

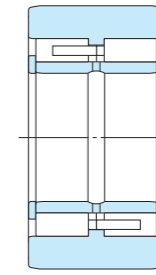

Design 6

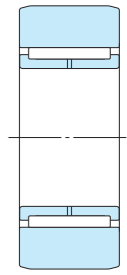

Design 7

Boundary dimensions (mm)						Basic load ratings (kN)		Fatigue limit load (kN) Cu	Bearing No.	Design	Bearing section height when manufactured (mm) H	Mass (kg)	Amount of bearings required per mill ¹⁾	Applicable multi-roll mill type	Applicable multi-roll mill rolls arrangement
$d(F_w)$	D	T	C	r	r_1	Cr	Cor								
31.75	76.2	46.23	45.85	0.8	1.5	121	183	31.5	06DC0846A	4	22.200	1.27	40	ZR34	
54.999	120	25.999	25.999	1.6	1.6	99.3	138	18.8	11N1226V	7	32.4672	1.69	24,56	ZR24	
55	120	52.197	52	1.6	1.6	254	341	45.9	11DC1252	4	32.483	3.27	40	ZR24	
70	160	90	90	1.5	1.5	434	546	81.2	14DC1690LDS-1	5	44.977	10.1	40	ZR33	
70	160.07	90	90	1.5	1.5	475	667	101	14DC1690ADS	1	45.000	10.5	32,48,72	ZR33	
90	190	100	100	3	3	593	770	109	18DC19100NDS	5	49.980	14.7	48	ZR25	
100	225.021	80	80	1.5	1.5	759	991	136	20DC23080DS	3	62.474	18.2	12 (36)	ZR23	
100	225.021	120	120	1.5	1.5	1020	1440	199	20DC23120MDS	1	62.474	27.2	32	ZR23	
100	225	100	100	3	1.5	683	838	114	20DC23100NDS-1	5	62.480	21.7	40	ZR23	
99.995	225	120	120	1.5	1.5	780	995	135	20DC23120KDS-2	2	62.474	26.0	32,40,48	ZR23	
130	300	160	159.5	4	3.5	1660	2340	297	26DC30160DS	1	84.9617	64.8	40,48	ZR22	
130	300	172.644	172.644	4	3.5	1950	2900	363	26DC30170MDS	1	84.955	72.6	40,48	ZR22	
130	300	172.644	172.644	4	3.5	1650	2210	275	26DC30170KDS-3	2	84.955	70	40,48	ZR22	
180	406.42	171.04	171.04	4	4	2580	3810	450	36DC41171DS	1	113.155	130	48,56	ZR21	
180	406.42	171.04	171.04	4	1	2390	3340	389	36DC41171ADS	6	113.155	124	48,56	ZR21	
180	406.42	171.04	171.04	4	3	2090	2960	346	36DC41171KDS	2	113.155	125	48	ZR21	
179.984	406.43	223.96	217	4	0.5	2940	4500	515	36DC41217DS+DP	1	113.155	161	40,48	ZR21	
179.984	406.43	224.25	220	4	3	2430	3530	405	36DC41224KDS	2	113.181	160	32,48	ZR21	
180	406.42	224.25	224	4	3	2860	4230	480	36DC41224QDS	5	113.155	162	40,48	ZR21	
50	110	44.4	44.4	1.1	1.1	158	167	24.5	10NUP1144	-	-	2.33	-	ZR22,ZR21	
50	125	48	46	2.0	1.1	202	213	28.0	10NUP1346/48	-	-	3.39	-	ZR21	
50	125	52	52	5.0	1.1	226	256	35.0	10NUP1352	-	-	3.8	-	ZR21	

Note 1) The numbers in parentheses, show necessary bearing quantities per mill. Differences in numbers in parentheses mean it is necessary to use other bearings as well.

Bearing dimensions table

A list of available bearings can be found in the following dimensions table. For any dimensions which are not on the table, please consult JTEKT.

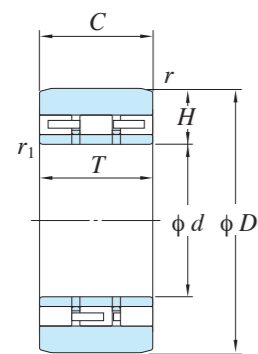

Dimensions mark design

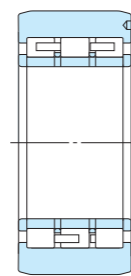

Design 8

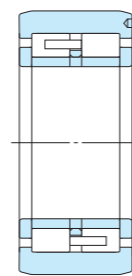

Design 9

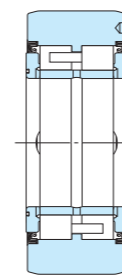

Design 10

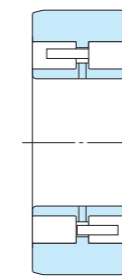

Design 11

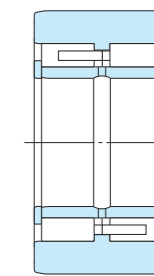

Design 12

Boundary dimensions (mm)						Basic load ratings (kN)		Fatigue limit load (kN) Cu	Bearing No.	Design	Bearing section height when manufactured (mm) H	Mass (kg)	Amount of bearings required per mill ¹⁾	Applicable multi-roll mill type	Applicable multi-roll mill rolls arrangement
$d(F_w)$	D	T	C	r	r_1	Cr	Cor								
50	120	80	80	1.5	1.5	335	379	56.4	10DC1280DS	9	34.976	5.15	32	12HI	
50	120	85	85	1.5	1.5	379	427	63.2	10DC1285DS	9	34.984	5.40	32		
60	160	95	95	1.5	2	498	589	88.3	12DC1695DS	9	46.484	11.5	20 (32)		
65	170	100	100	2	2	498	597	89.6	13DC17100DS	9	52.480	13.5	10 (34)		
90	230	100	100	2	3	802	982	133	18DC23100DS	9	69.980	24.2	24 (34)		
100	260	95	95	2	2	871	1060	143	20DC2695DS	9	79.970	30.2	32		
100	260	105	105	2	2	975	787	161	20DC26105DS	9	79.970	33.5	32		
90	260	125	125	2	2	1150	1520	197	18DC26125DS	9	84.970	41.3	34		
100	260	130	130	2	2	1190	1580	204	20DC26130DS	9	79.970	41.5	32		
110	280	165	165	2	2	1390	1880	250	22DC28165DS	8	84.965	60.2	10 (34)		
120	280	165	165	2	3	1380	1940	244	24DC28165DS	9	79.965	57.7	14 (38)		
120	350	165	165	2	3	1710	2220	273	24DC35165ADS	12	114.965	98.3	24 (34)		
130	350	175	175	2	3	1750	2300	281	26DC35175DS	12	109.965	101	24 (38)		
62	155	90	90	1	2	445	529	78.3	12DC1690DS	9	46.484	9.97	8 (44)	20HI	
62	155	110	110	1	2	505	622	95.6	12DC16110DS	8	46.484	12.2	36 (44)		
90	220	95	95	2	2	664	795	112	18DC2295DS	9	64.982	20.9	40		
90	220	130	130	2	2	873	1130	158	18DC22130ADS	8	64.982	28.7	32,40		
115	260	140	140	3	2	1220	1690	225	23DC26140DS	8	72.470	41.9	40		
65	165	70	70	1.5	2	531	586	90.1	13DC1770DS	11	49.982	8.83	40		
90	220	94	94	2	1.5	860	997	138	18DC2294DS	11	64.976	21.2	40		
90	220	96	94	3	3	618	700	101	18DC2294/96DS	10	65.000	21.0	64		
130	300.02	130	129	2	3	1300	1740	215	26DC30130DS	9	85.010	52.2	56		
130	300.02	130	129	4	3.5	1340	1620	206	26DC30130BDS	10	85.010	51.8	-		
130	300.02	132	129	2	3	1430	1830	231	26DC30132ADS	9	85.010	53.8	72		

Note 1) The numbers in parentheses, show necessary bearing quantities per mill. Differences in numbers in parentheses mean it is necessary to use other bearings as well.

Improving ease of outer ring regrinding work

We provide regrinding jigs which are capable of grinding the outer ring outside diameter of the bearing with high accuracy.

Bearing-regrinding Jigs

Advantages

- The jigs minimize the radial run out of the bearings after regrinding.

Once the bearing is installed into the jig, the jig completely nullifies any clearance on the fitting surface between the jig and bearing and the internal clearance of the bearing, eliminating play in the radial direction. The jig grinds the outside diameter surface while turning the outer ring and retaining the inner ring as stationary, enabling grinding under the same conditions as when in operation. Grinding of the bearings radial run-out can be performed with a high level of accuracy.

- The jigs improve efficient installation and removal

Bearings can be installed on and removed from the jig easily without the need of disassembling the inner ring and outer ring. There is no possibility that rollers will come off.

Overview

The outer surfaces of the bearings used on the backing shafts of multi-roll mills should be ground periodically to retain precise bearing performance, thus ensuring the quality of rolled products. **JTEKT** supplies the jigs that grind bearing's outside diameter surface with high precision.

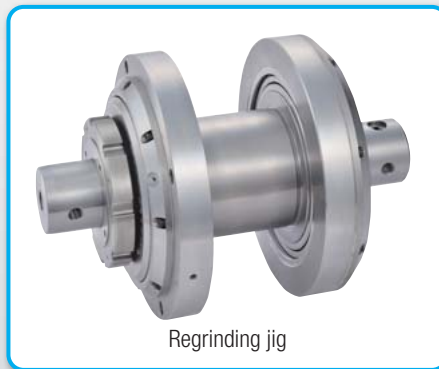

Required performance and issues

- Improving ease of outer ring regrinding work

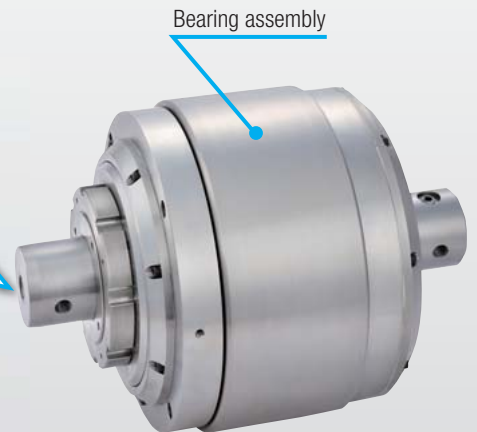
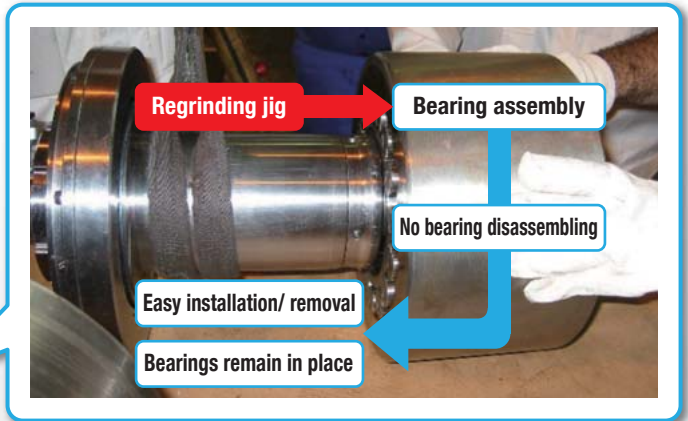

Cylindrical grinder for outer ring-regrinding

JTEKT provides the GE series which is capable of processing both roll grinding and outer ring-regrinding with high accuracy using cylindrical grinders. (TOYODA brand)

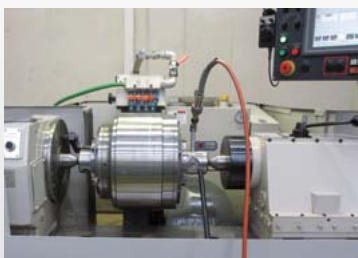

Mounting the regrinding jig and bearing assembly to the cylindrical grinder



Jig type and constructions

The jigs come in two types, which should be selected according to the dimensions and types of backing-shaft bearings. Please specify the type suitable to your needs.

Type 1

This type of jig is suitable for bearings over 70mm bore with an outer ring rib. This jig requires a hole for the work carrier on the side face of outer ring.

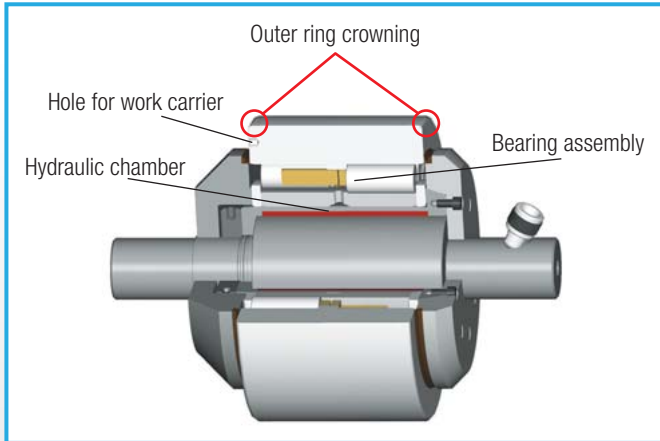

Typical installation of suitable bearing on jig Type 1

Type 2

This type of jig is suitable for both bearings with and without outer ring rib. It is used on the Sendzimir Rolling Mills ZR21 and ZR22.

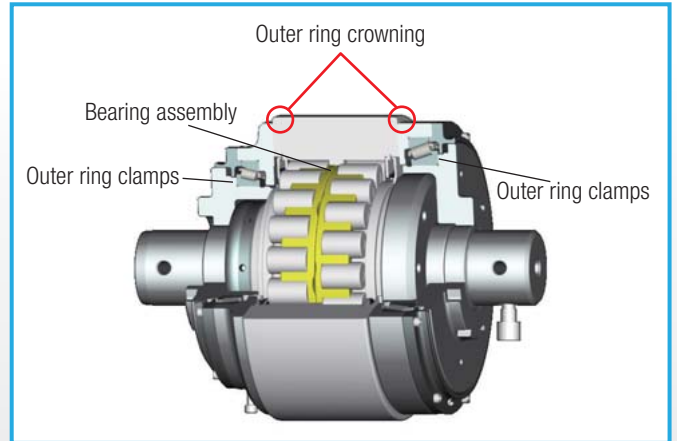

Typical installation of suitable bearing on jig Type 2

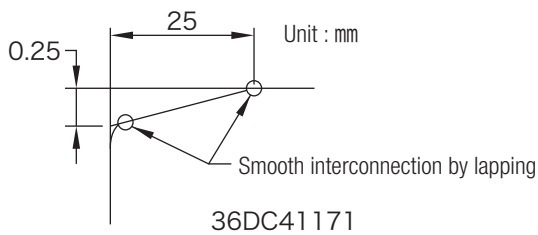

36DC41171

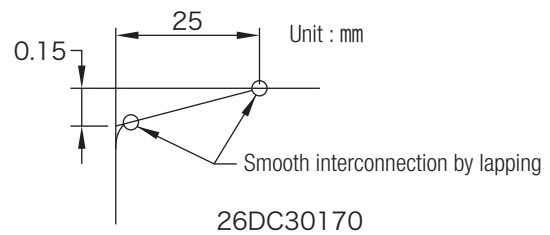

26DC30170

Example of Outer ring crowning dimensions

Measurement for bearing section height

Advantages

- possible to measure to 1/1000mm
- possible to measure bearings radial run-out
- easy bearing installation / removal

Overview

When the outer surface of a bearing is ground, it is critical to accurately control the variation of bearing's section heights of all the bearings installed on the backing shaft. **JTEKT** supplies Measurement for bearing section height that suit the individual bearings listed on the dimensional table.

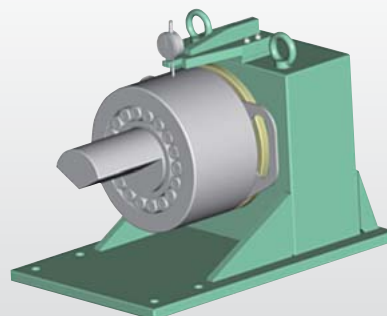
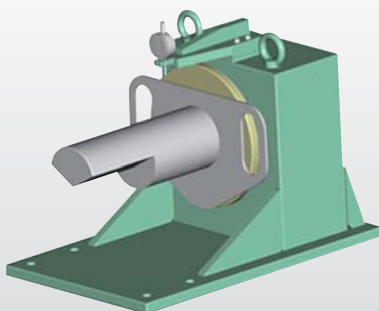

Large size bearing technology development center

JTEKT's accumulated knowledge and experience helps our customers solve problems. We provide new high value-added products and processes for businesses by having developed a global supply system to meet those demands.



JTEKT established a large size bearing technology development center to evaluate and analyze large size bearing uses in the industrial machinery field.

Until now, with regards to large size bearings used in the industrial machinery field, investment was made in the actual machines before accurate modeling was done resulting in customer dissatisfaction. As a result, development time took too long due to the problems that arose.

Now, we are able to simulate and evaluate production conditions close to the real machines in our large size bearing technology developing center.

The accumulated data for bearing testing equipment for steel production equipment introduced has allowed us to improve the accuracy of CAE analysis (simulation analysis) which gives us a significant reduction for the products developmental period and in the development of new high value-added products for the future.

■ Bearing testing equipment for steel production equipment

Our testing equipment is able to evaluate the scattering rolling mill water under a high temperature environment to recreate close to actual conditions.

In this way, we can deliver bearings and oil seal components with excellent performance.



OFFICES

KOYO CANADA INC.

5324 South Service Road, Burlington, Ontario L7L 5H5, CANADA
TEL : 1-905-681-1121
FAX : 1-905-681-1392

JTEKT NORTH AMERICA CORPORATION

-Main Office-

47771 Halyard Drive, Plymouth, MI 48170, U.S.A.
TEL : 1-734-454-1500
FAX : 1-734-454-7059

-Cleveland Office-

29570 Clemens Road, P.O.Box 45028, Westlake,
OH 44145, U.S.A.
TEL : 1-440-835-1000
FAX : 1-440-835-9347

KOYO MEXICANA, S.A. DE C.V.

Av. Insurgentes Sur 2376-505, Col. Chimalistac, Del. Álvaro
Obregón, C.P. 01070, México, D.F.
TEL : 52-55-5207-3860
FAX : 52-55-5207-3873

KOYO LATIN AMERICA, S.A.

Edificio Banco del Pacífico Planta Baja, Calle Aquilino de la
Guardia y Calle 52, Panama, REPUBLICA DE PANAMA
TEL : 507-208-5900
FAX : 507-264-2782/507-269-7578

KOYO ROLAMENTOS DO BRASIL LTDA.

Avenida Reboucas, 2472 Jardim America, CEP 05402-300 São
Paulo, BRAZIL
TEL : 55-11-3372-7500
FAX : 55-11-3887-3039

KOYO MIDDLE EAST FZCO

6EA 601, Dubai Airport Free Zone, P.O. Box 54816, Dubai, U.A.E.
TEL : 97-1-4299-3600
FAX : 97-1-4299-3700

KOYO BEARINGS INDIA PVT. LTD.

C/o Stylus Commercial Services PVT LTD, Ground Floor, The
Beech, E-1, Manyata Embassy Business Park, Outer Ring Road,
Bengaluru-560045, INDIA
TEL : 91-80-4276-4567 (Reception Desk of Service Office)
FAX : 91-80-4276-4568

JTEKT (THAILAND) CO., LTD.

172/1 Moo 12 Tambol Bangwua, Amphur Bangpakong,
Chachoengsao 24180, THAILAND
TEL : 66-38-533-310~7
FAX : 66-38-532-776

PT. JTEKT INDONESIA

Jl. Surya Madya Plot I-27b, Kawasan Industri Surya Cipta,
Kutanegara, Ciampel, Karawang Jawa Barat, 41363 Indonesia
TEL : 62-267-8610-270
FAX : 62-267-8610-271

KOYO SINGAPORE BEARING (PTE.) LTD.

27, Penjuru Lane, Level 5, Phase 1 Warehouse #05-01,
SINGAPORE 609195
TEL : 65-6274-2200
FAX : 65-6862-1623

PHILIPPINE KOYO BEARING CORPORATION

6th Floor, One World Square Building, #10 Upper McKinley
Road, McKinley Town Center Fort Bonifacio, 1634 Taguig City,
PHILIPPINES
TEL : 63-2-856-5046/5047
FAX : 63-2-856-5045

JTEKT KOREA CO., LTD.

Seong-do Bldg 13F, 207, Dosan-Dearo, Gangnam-Gu, Seoul,
KOREA
TEL : 82-2-549-7922
FAX : 82-2-549-7923

JTEKT (CHINA) CO., LTD.

Room.25A2, V-CAPITAL Building, 333 Xianxia Road, Changning
District, Shanghai 200336, CHINA
TEL : 86-21-5178-1000
FAX : 86-21-5178-1008

KOYO AUSTRALIA PTY. LTD.

Unit 2, 8 Hill Road, Homebush Bay, NSW 2127, AUSTRALIA
TEL : 61-2-8719-5300
FAX : 61-2-8719-5333

JTEKT EUROPE BEARINGS B.V.

Markerkant 13-01, 1314 AL Almere, THE NETHERLANDS
TEL : 31-36-5383333
FAX : 31-36-5347212

-Benelux Branch Office-

Energieweg 10a, 2964 LE, Groot-Ammers, THE NETHERLANDS
TEL : 31-184606800
FAX : 31-184606857

KOYO KULLAGER SCANDINAVIA A.B.

Johanneslundsvägen 4, 194 61 Upplands Väsby, SWEDEN
TEL : 46-8-594-212-10
FAX : 46-8-594-212-29

KOYO (U.K.) LIMITED

Whitehall Avenue, Kingston, Milton Keynes MK10 0AX,
UNITED KINGDOM
TEL : 44-1908-289300
FAX : 44-1908-289333

KOYO DEUTSCHLAND GMBH

Bargkoppelweg 4, D-22145 Hamburg, GERMANY
TEL : 49-40-67-9090-0
FAX : 49-40-67-9203-0

KOYO FRANCE S.A.

6 avenue du Marais, BP20189, 95105 Argenteuil, FRANCE
TEL : 33-1-3998-4202
FAX : 33-1-3998-4244/4249

KOYO IBERICA, S.L.

Avda.de la Industria, 52-2 izda 28820 Coslada Madrid, SPAIN
TEL : 34-91-329-0818
FAX : 34-91-747-1194

KOYO ITALIA S.R.L.

Via Stephenson 43/a 20157 Milano, ITALY
TEL : 39-02-2951-0844
FAX : 39-02-2951-0954

-Romanian Representative Office-

24, Lister Street, ap. 1, sector 5, Bucharest, ROMANIA
TEL : 40-21-410-4182
FAX : 40-21-410-1178

PUBLISHER

JTEKT CORPORATION NAGOYA HEAD OFFICE

No.7-1, Meieki 4-chome, Nakamura-ku, Nagoya, Aichi 450-8515, JAPAN TEL : 81-52-527-1900 FAX : 81-52-527-1911

JTEKT CORPORATION OSAKA HEAD OFFICE

No.5-8, Minamisemba 3-chome, Chuo-ku, Osaka 542-8502, JAPAN TEL : 81-6-6271-8451 FAX : 81-6-6245-3712

Sales & Marketing Headquarters

No.5-8, Minamisemba 3-chome, Chuo-ku, Osaka 542-8502, JAPAN TEL : 81-6-6245-6087 FAX : 81-6-6244-9007

The contents of this catalogue may be changed without notice. We take full responsibility for all correction contents with the exceptions of error in writing, omission and misprints during printing.

This catalogue is protected under copyright. Any and all reproduction in any form is forbidden without express written consent of JTEKT CORPORATION.

Value & Technology

