

Koyo[®]

**CERAMIC BEARINGS
AND *EXSEV* BEARINGS
FOR EXTREME SPECIAL ENVIRONMENTS**



**CERAMIC
&
EXSEV**

Extreme special environment

JTEKT | JTEKT CORPORATION

JTEKT

Koyo | **TOYODA**

CAT. NO. B2004E-1



CERAMIC BEARINGS AND **EXSEV** BEARINGS FOR EXTREME SPECIAL ENVIRONMENTS

CAT. NO. B2004E-1

☆ JTEKT CORPORATION does not export its products and engineering know-how unless in compliance with the Foreign Exchange and Foreign Trade Control Act and other applicable trade-related regulations, if they are so covered by such act and regulations. Accordingly, please contact our branch office or sales office if you intend to export any product described in this catalogue.

☆ The contents of this catalogue are subject to change without prior notice. We took special care in preparing the contents of this catalogue. JTEKT does not accept liability for errors, omissions, or missing pages, or any loss incurred from the use of this catalogue.

Reproduction of this catalogue or any part thereof without JTEKT's prior permission is strictly prohibited.

Value & Technology

Koyo CERAMIC BEARINGS AND **EXSEV** BEARINGS
FOR EXTREME SPECIAL ENVIRONMENTS

CONTENTS

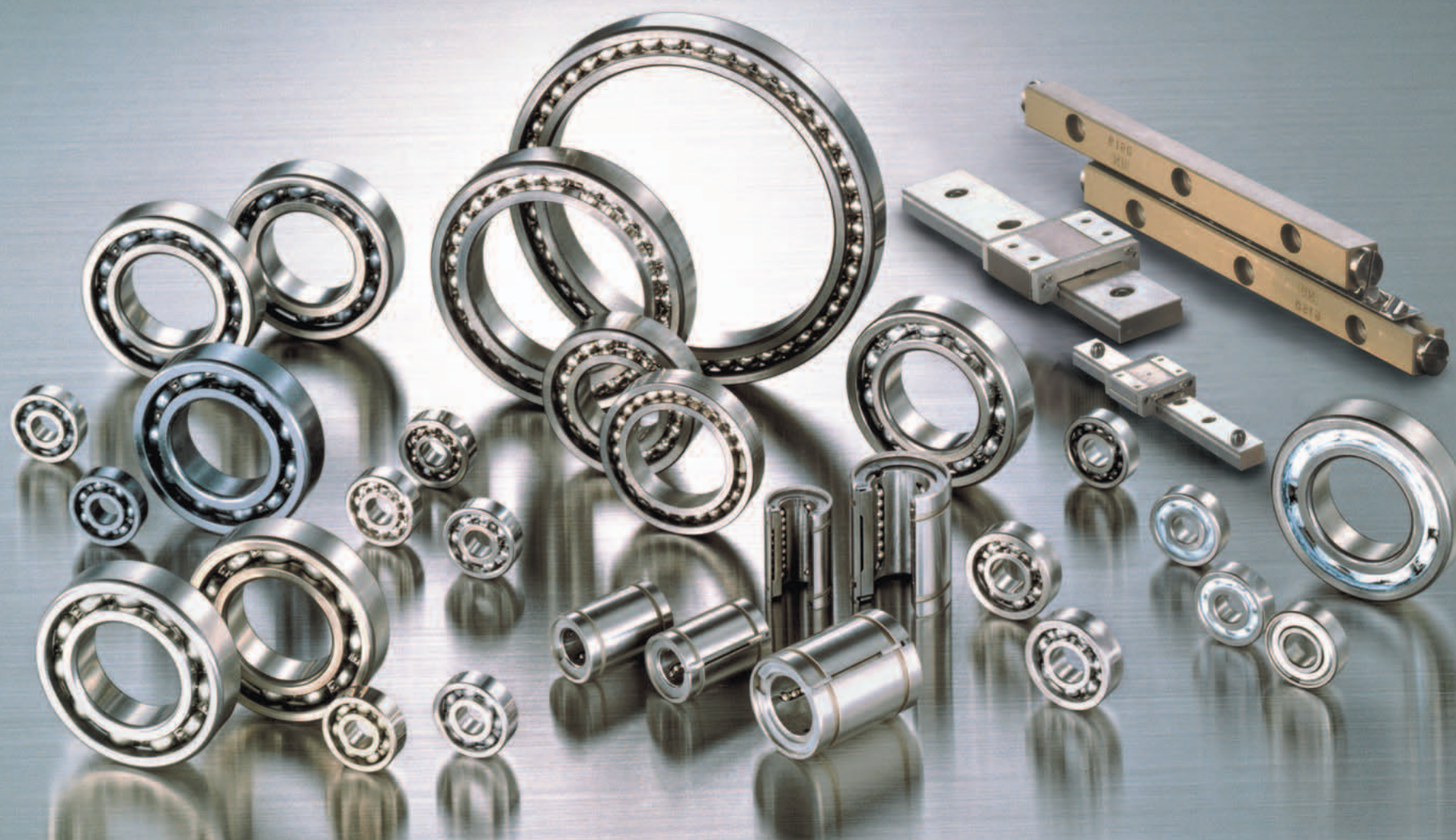

Products and Applications

Development and Manufacturing Facilities

1 EXSEV Bearings: Composition and Selection

1 Ceramic Bearings and Special Steel Bearings 3
2 Lubricants for EXSEV Bearings 11
3 How to Select EXSEV Bearings 14
4 EXSEV Bearings with Special Characteristics 19

2 EXSEV Bearings and Other EXSEV Products

1 Ceramic Bearings and EXSEV Bearings: Table of Specifications 23
2 Ceramic Bearings and EXSEV Bearings: Table of Characteristics 25
3 Radial Ball Bearings 29
4 K Series Full Complement Hybrid Ceramic Ball Bearing 63
5 Linear Motion Bearings 65
6 High Ability Angular Contact Ball Bearings 85
7 Ceramic Balls 88
8 Tolerance and Internal Clearance of Ceramic Bearings
and EXSEV Bearings 89

3 Application Examples

1 Clean Environments 93
2 Vacuum Environments 97
3 High Temperature Environments 99
4 Corrosive Environments 101
5 Magnetic Field Environments 104
6 Electric Field Environments 105
7 High Speed Applications 107

4 Supplementary Tables

1 Shaft Tolerances 113
2 Housing Bore Tolerances 115
3 Numerical Values for Standard Tolerance Grades IT 117
4 Steel Hardness Conversion 118
5 SI Units and Conversion Factors 119
6 Inch / millimeter Conversion 123
7 Cleanliness Classes 124

Specifications Sheet

Products and Applications

Koyo Ceramic Bearings and **EXSEV** Bearings for Extreme Special Environments are used for a wide range of the state of the art technologies.

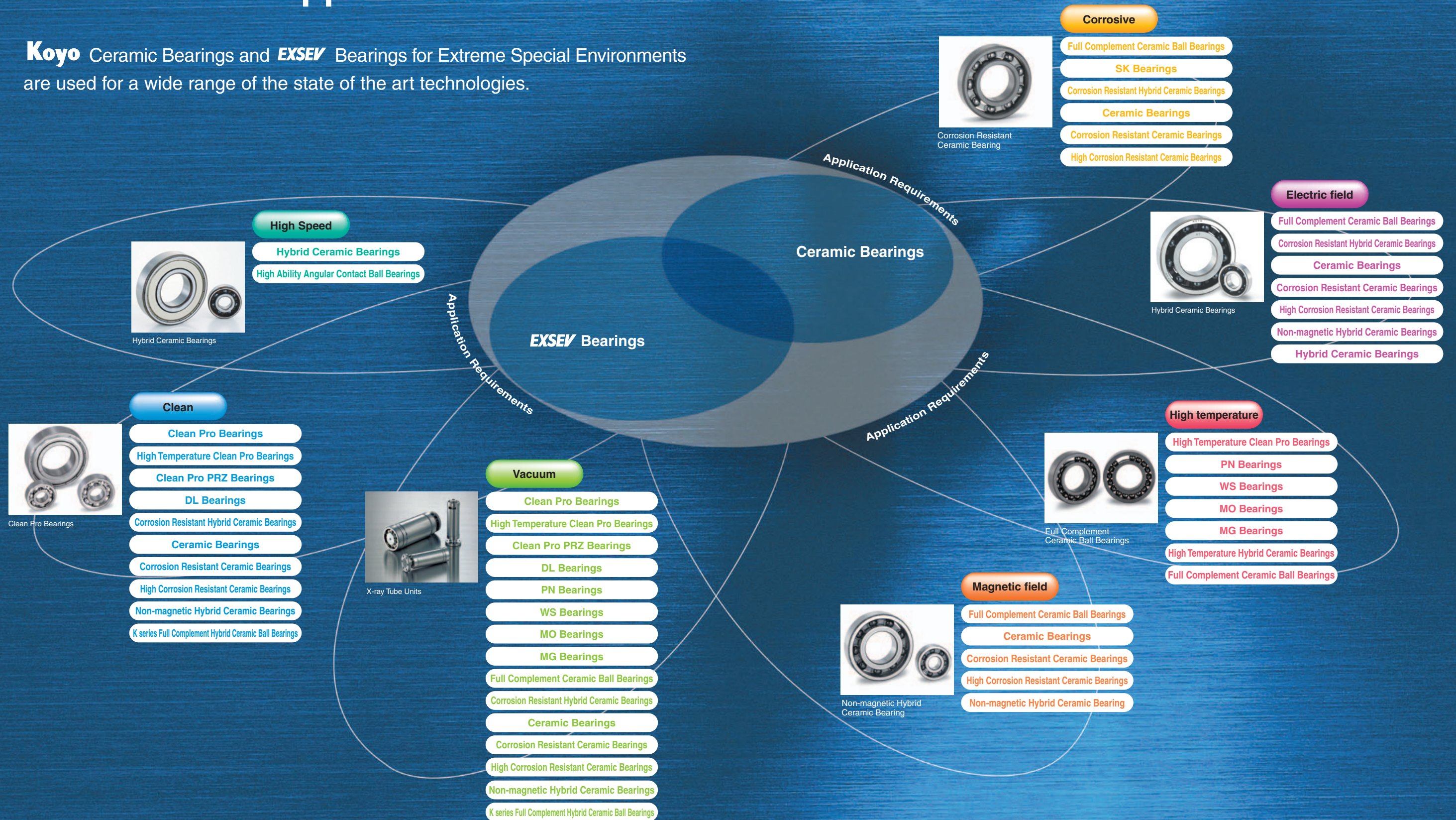

EXSEV BEARING SERIES

Development and Manufacturing Facilities

By continuously incorporating new improvements, Koyo Ceramic Bearings and **EXSEV** Bearings are applicable in more technologies than ever.

Technologies are advancing rapidly and bearings are required to satisfy more complicated and varied requirements under increasingly hostile operating conditions.

In response to such needs, JTEKT is committed to the development and manufacture of the EXSEV Bearing Series using the latest research / development and manufacturing facilities.

JTEKT intends to supply products that live up to customers' expectations, while contributing to environmental conservation and energy saving through streamlined manufacturing.

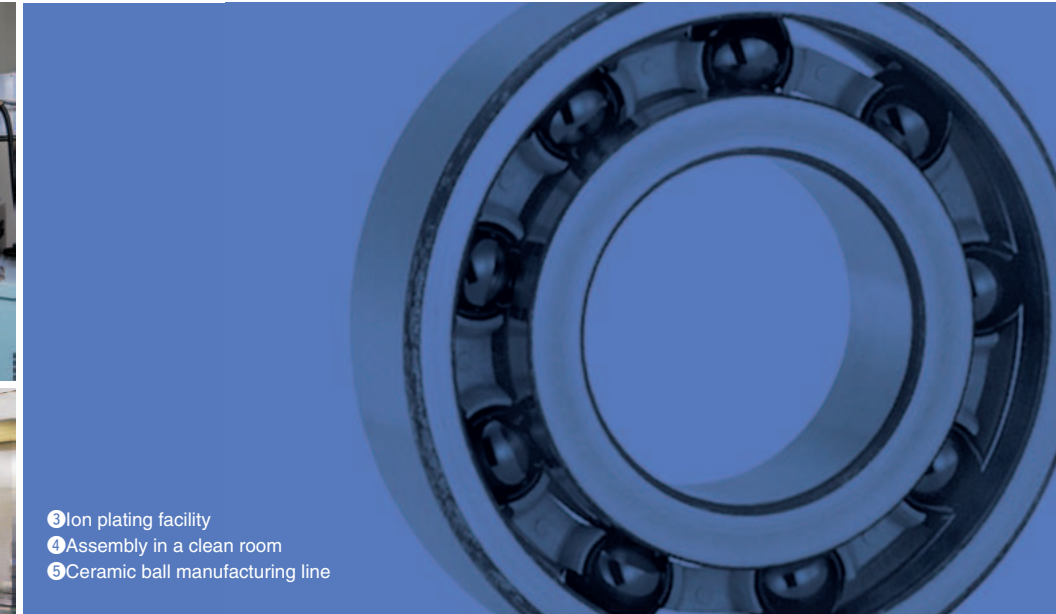

- ③ Ion plating facility
- ④ Assembly in a clean room
- ⑤ Ceramic ball manufacturing line



Research & Development Centers



Bearing Business Operations Headquarters



- ① Corrosion resistant bearing tester
- ② Sputtering machine
Plasma chemical vapor deposition system

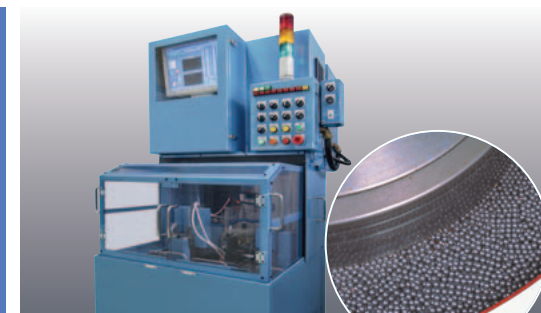

Tokushima Plant

RESEARCH AND DEVELOPMENT

1 *EXSEV* Bearings: Composition and Selection

Conventional bearings, made from bearing steel, and lubricants such as oil and grease, may not be applicable in an extreme special environment such as a clean room, vacuum, high temperature application or corrosive environment, or when special characteristics are required, such as being non-magnetic, or insulating, or having superior high speed performance.

Koyo *EXSEV* Bearings are a special bearing series, developed specifically to address such needs.

Please consult JTEKT when using bearings in a new, unprecedented environment, or when bearings with special characteristics are required.



1 Ceramic Bearings and Special Steel Bearings

1-1 Ceramic Bearings 3

■ Properties of ceramic materials

■ Load ratings and service life of ceramic bearings

1-2 Special Steel Bearings 10

2 Lubricants for *EXSEV* Bearings

2-1 Grease 11

2-2 Solid Lubricants 12

3 How to Select *EXSEV* Bearings

3-1 Clean Environments 14

3-2 Vacuum Environments 15

3-3 High Temperature Environments 16

3-4 Corrosive Environments 17

4 *EXSEV* Bearings with Special Characteristics

4-1 Non-magnetic Bearings 19

4-2 Insulating Bearings 19

4-3 High Speed Bearings 20

1 Ceramic Bearings and Special Steel Bearings

The EXSEV Bearing Series has been developed for use in special applications where conventional bearings are not practical.

The EXSEV Bearings incorporate components made from special material and use special lubricants, to be applicable in extreme special environments such as a clean room, vacuum,

high temperature application, or corrosive condition, and to realize special characteristics, such as being non-magnetic, or insulating, or having superior high speed performance.

The EXSEV Bearing series consist of Ceramic Bearings and Special Steel Bearings, depending on the specific materials of the components.

1-1 Ceramic Bearings

Ceramic Bearings, including components made from ceramic, have the special properties that steel bearings do not have, such as being non-magnetic or insulating. They can be used in new applications where conventional bearings have not been practical.

Ceramic Bearings are highly heat resistant, enabling a rolling bearing to be practical in a high temperature environment. The low density of ceramic decreases the centrifugal force induced by rolling elements (balls or rollers), contributing to an increased speed of the apparatus.

Properties of ceramic materials

1) Material characteristics

Table 1-1 below lists the mechanical and physical properties of major ceramic materials used as bearing materials. Table 1-2 compares silicon nitride and high carbon chromium bearing steel.

Table 1-1 Mechanical and physical properties of ceramic materials used as bearing materials

Property	Unit	Ceramic Material	Silicon Nitride Si ₃ N ₄	Zirconia ZrO ₂	Silicon Carbide SiC
Density	g/cm ³		3.2	6.0	3.1
Linear expansion coefficient	K ⁻¹		3.2×10 ⁻⁶	10.5×10 ⁻⁶	3.9×10 ⁻⁶
Vickers hardness	HV		1 500	1 200	2 200
Module of longitudinal elasticity	GPa		320	220	380
Poisson's ratio			0.29	0.31	0.16
Three point bending strength	MPa		1 100	1 400	500
Fracture toughness	MPa · m ^{1/2}		6	5	4
Heat resistance (in atmospheric air)	°C		800	200	1 000 or higher
Thermal shock resistance	°C		750 or higher	350	350
Coefficient of thermal conductivity	W/(m · K)		20	3	70
Specific heat	J/(kg · K)		680	460	670

Table 1-2 Comparison of characteristics of silicon nitride and high carbon chromium bearing steel

Property	Unit	Silicon Nitride Si ₃ N ₄	High Carbon Chromium Bearing Steel SUJ2	Advantages of Ceramic Bearings
Density	g/cm ³	3.2	7.8	Decrease in centrifugal force induced by rolling elements (balls or rollers) → Longer service life and reduced bearing temperature rises
Linear expansion coefficient	K ⁻¹	3.2×10 ⁻⁶	12.5×10 ⁻⁶	Decreased internal clearance change due to reduced bearing temperature rises → Lowered vibration and reduced preload changes
Vickers hardness	HV	1 500	750	Less deformation in rolling contact areas → Higher rigidity
Module of longitudinal elasticity	GPa	320	208	
Poisson's ratio		0.29	0.3	Retention of superior load carrying characteristics under high temperature
Heat resistance	°C	800	180	
Corrosion resistance		High	Low	Useful in acid or alkaline solutions
Magnetism		Non-magnetic	Ferromagnetic	Decreased rotational fluctuation in ferromagnetic field due to non-magnetization
Conductivity		insulator	conductor	Prevents electrical pitting
Bond		Covalent bond	Metallic bond	Decrease in adhesion (or material transfer) due to oil film thinning in rolling contact areas

2) Rolling fatigue of ceramic materials

The individual ceramic materials were tested for rolling fatigue under oil lubrication and under water lubrication, to evaluate their applicability as bearing material. Figs. 1-1 and 1-2 show the results of the tests.

The figures indicate that each ceramic material has a certain level of rolling fatigue strength and that silicon nitride has the highest fatigue strength among the ceramic materials tested.

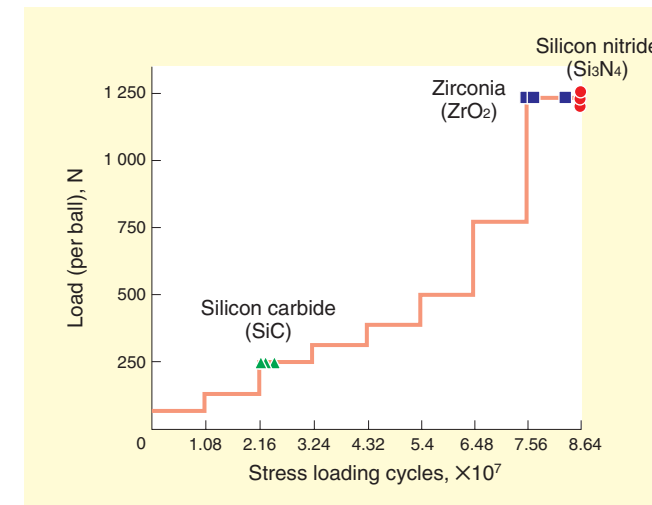

Fig. 1-1 Comparison in rolling fatigue life under oil lubrication

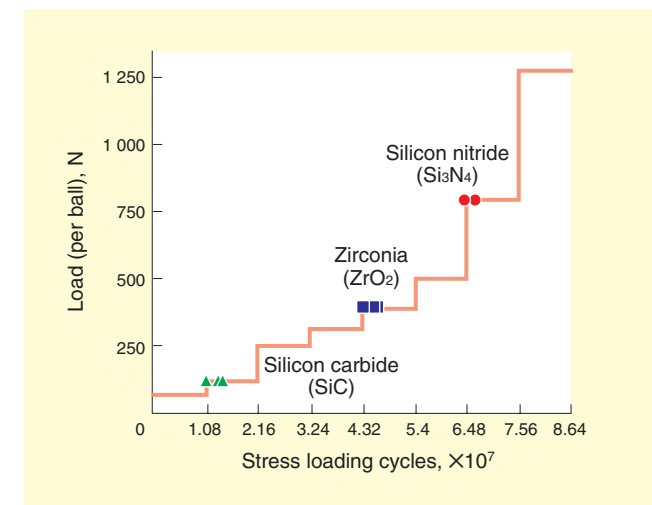
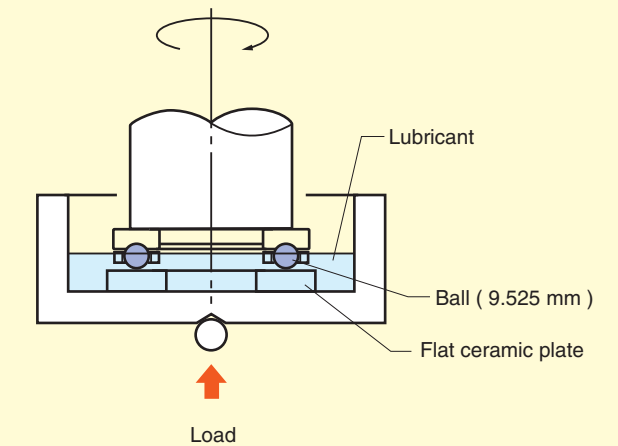

Fig. 1-2 Comparison in rolling fatigue life under water lubrication

Test conditions

	Oil lubrication	Water lubrication
Lubricant	Spindle oil	City water
Ball	Bearing steel	Ceramic
Load	Increased in stages at every 1.08 × 10 ⁷ cycles	
Rotational speed	1 200 min ⁻¹	

Test equipment



Test equipment appearance



Fig. 1-3 Rolling fatigue life test conditions and test equipment

3) Ceramic materials suitable for rolling bearings

Table 1-3 shows the results of evaluating the ceramic materials in terms of their characteristics and the rolling fatigue strength. Among the ceramic materials tested, silicon nitride is the most suitable as rolling bearing material.

JTEKT uses the silicon nitride produced by the hot isostatic pressing (HIP) method as the standard ceramic material for bearings.

4) Composition of ceramic bearings

Koyo ceramic bearings are divided into Full Ceramic Bearings (with all components, namely, the outer ring, inner ring and rolling elements, made of ceramic) and Hybrid Ceramic Bearings (with only the rolling elements made of ceramic). The outer ring and inner ring of the Hybrid Ceramic Bearings are made from special steel, including high carbon chromium bearing steel. The cage may be made of a metallic material, resin, or composite material, depending on the intended operating conditions of the bearing.

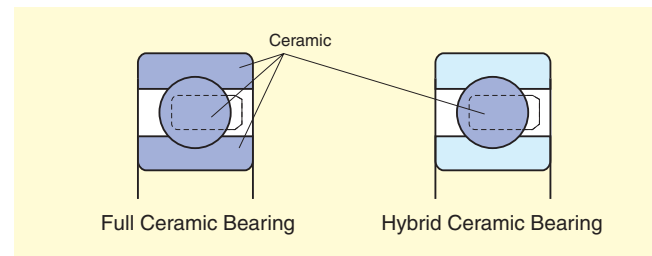

Fig. 1-4 Composition of ceramic bearings

● Table 1-3 Ratings of ceramic materials as rolling bearing materials

	Application to rolling bearings		
	Rating	Performance and use	Characteristics
Silicon nitride Si ₃ N ₄	◎	<ul style="list-style-type: none"> Comparable to bearing steel in load carrying capability and service life Suitable for high performance applications 	<ul style="list-style-type: none"> High speed High vacuum Corrosion resistant Heat resistant Non-magnetic High rigidity
Zirconia ZrO ₂	○	<ul style="list-style-type: none"> Useful under a limited load Applicable in highly corrosive chemicals 	<ul style="list-style-type: none"> Highly corrosion resistant
Silicon carbide SiC	○	<ul style="list-style-type: none"> Useful under a limited load Applicable in highly corrosive chemicals 	<ul style="list-style-type: none"> Highly corrosion resistant Highly heat resistant

Load ratings and service life of ceramic bearings

Silicon nitride, a ceramic material, is more rigid than high carbon chromium bearing steel; therefore, a bearing including silicon nitride components is subject to a higher contact stress on the area of contact between bearing raceways and rolling elements. Accordingly, to estimate the service life of ceramic bearings, whether the rolling bearing theory is applicable or not is critical.

Basic dynamic load rating

The ISO standard defines the basic dynamic load rating as the pure radial load (for radial bearings), constant in magnitude and direction, under which the basic rating life of 1 million revolutions can be obtained, when the inner ring rotates while the outer ring is stationary or vice versa. The basic dynamic load rating represents the resistance of a bearing against rolling fatigue.

Basic static load rating

The basic static load rating is defined as the static load which corresponds to the calculated contact stress shown below, at the center of the most heavily loaded raceway/rolling elements.

- Self-aligning ball bearings : 4 600 MPa
- Other ball bearings : 4 200 MPa
- Roller bearings : 4 000 MPa

JTEKT defines the dynamic load rating and static load rating of ceramic bearings based on the results of their service life tests, the maximum allowable static load of the ceramic materials, the elastic deformation test results of high carbon chromium bearing steel, and other related data, as shown in Table 1-4.

● Table 1-4 Load ratings of ceramic bearings

	Full Ceramic Bearing	Hybrid Ceramic Bearing
Dynamic load rating <i>C_r</i>	Comparable to steel bearings	Comparable to steel bearings
Static load rating <i>C_{0r}</i>	Comparable to steel bearings	85% that of steel bearings

The steel bearings here refer to bearings consisting of rings and rolling elements both made of high carbon chromium bearing steel.

1) Rolling fatigue life of ceramic bearings

A typical service life test for Ceramic Bearings and steel bearings was performed under the conditions specified in Fig. 1-6.

The test results showed that the service life of Ceramic Bearings was equal to or longer than that of steel bearings, exceeding the calculated life.

The Ceramic Bearings were found to exhibit flaking (Fig. 1-5) when their service life terminated. The same phenomenon was observed on the steel bearings whose service life terminated.

Based on these findings, as the dynamic load rating of a Ceramic Bearing, that of a steel bearing of the same dimensions can be used.

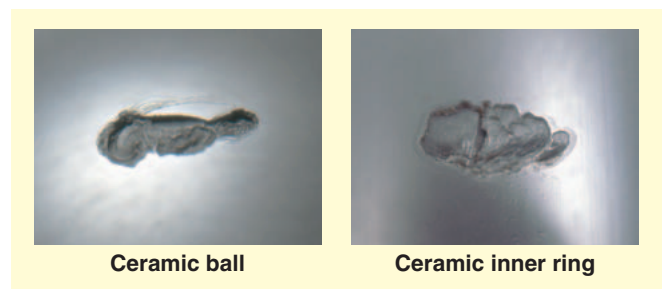
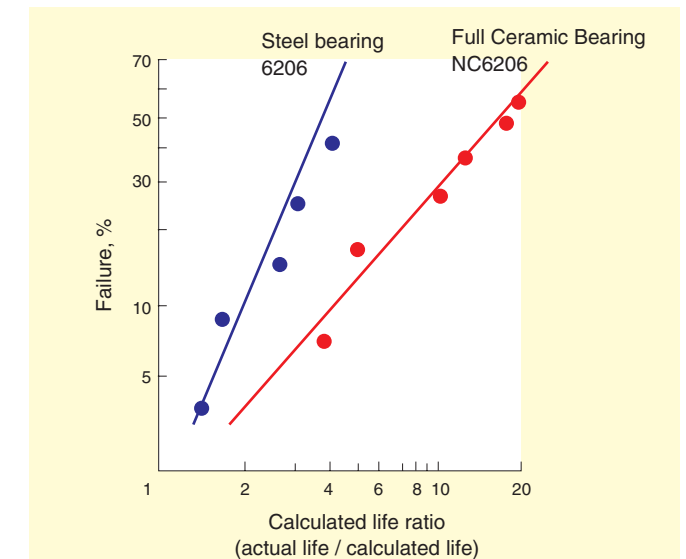

Fig. 1-5 Flaking on ceramic ball and inner ring



Rolling fatigue test conditions

Bearing number	Material (outer/inner rings and balls)	Dimensions, mm
NC6206	Silicon nitride(Si ₃ N ₄)	30 × 62 × 16 (bore × outside dia. × width)
6206	Bearing steel(SUJ2)	

Specification	Condition
Load	5 800 N
Rotational speed	8 000 min ⁻¹
Lubrication oil	AeroShell Turbine Oil 500
Temperature	70 ± 2 °C

Fig. 1-6 Rolling fatigue life of Full ceramic bearings and steel bearings

2) Static load rating of ceramic bearings

The basic static load rating of a steel bearing represents a load that produces a localized permanent deformation in the rolling element/raceway contact area, impeding smooth rotation.

However, ceramic materials, which are highly rigid, produce little permanent deformation. Therefore, the theory of the basic static load rating for steel bearings is not applicable to ceramic bearings.

• Static load rating of Full Ceramic Bearings

When exposed to continuous excessive loads, ceramic materials may break down; however, before breakdown occurs, the materials develop cracking.

Fig. 1-7 compares the load measurements at which ceramic balls developed cracking with the basic static load ratings of steel bearings. Fig. 1-8 shows the measurement system.

As these results show, the loads at which cracks develop on the Full Ceramic Bearing are far higher than that of the basic static load rating of steel bearings. This means that the basic load ratings specified in the ISO standard can be used as the allowable static loads of the Full Ceramic Bearing.

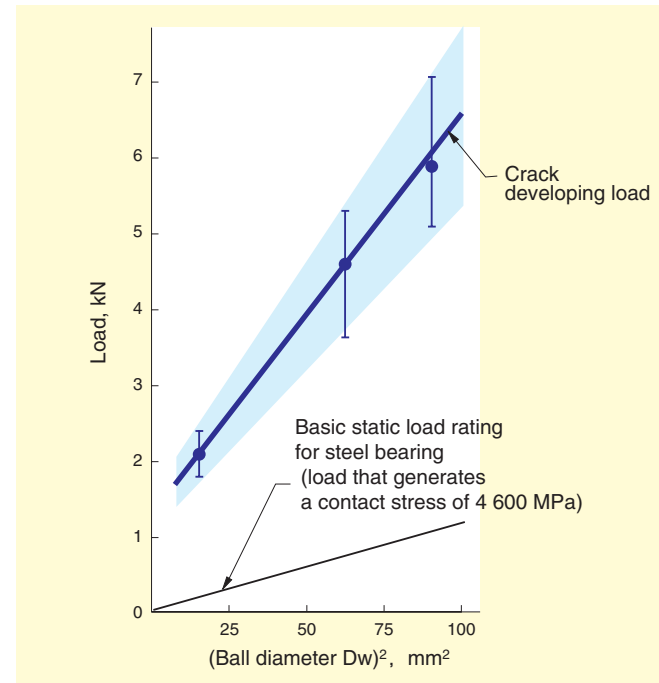

Fig. 1-7 Crack developing loads for Full Ceramic Bearings

• Static load rating of Hybrid Ceramic Bearings

The theory of the static load rating for steel bearings is applicable to Hybrid Ceramic Bearings because their outer and inner rings are made of steel and accordingly any deformation is permanent.

Table 1-5 shows the results of a test for which a high carbon chromium bearing steel ball and ceramic ball were pressed against a flat plate of high carbon chromium bearing steel and the resulting permanent deformations (indentation depths) on the flat plate and balls were measured.

• Table 1-5 Measurements of permanent deformation produced on flat steel plate and balls

	Load kN	Permanent deformation (average), mm		Permanent deformation (sum of averages), mm
		Flat plate (bearing steel)	Ball	
Ceramic ball	0.65	0.5	—	0.5
	1.3	1.9	—	1.9
	2.6	5.2	—	5.2
	3.9	9.3	—	9.3
Steel ball	0.65	0.4	—	0.4
	1.3	1.3	0.11	1.41
	2.6	4.0	0.41	4.41
	3.9	6.8	1.18	7.98

These results indicate that ceramic balls do not suffer permanent deformation and that the permanent deformation produced on the flat steel plate by the ceramic balls is approximately 1.2 times the sum of the deformation produced on the flat plate by steel ball and the deformation that the steel ball undergo.

Accordingly, the static load rating of Hybrid Ceramic Bearings can be determined based on the permanent deformation of their bearing steel rings. JTEKT uses the load equal to 85% of the static load rating of steel bearings as the static load rating of the Hybrid Ceramic Bearings.

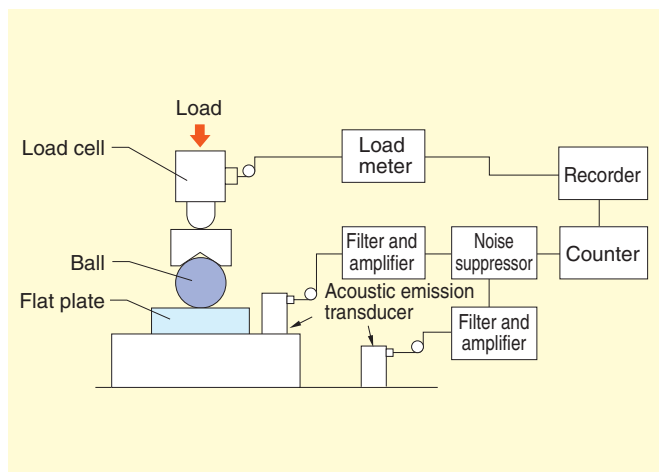

Fig. 1-8 Crack generating load measurement system

3) Impact strength of ceramic bearings

To evaluate the impact strength of ceramic bearings, ceramic balls were crushed by two methods: by a static load and an impact load. The test results are shown in Fig. 1-9. Fig. 1-10 shows the testing methods.

This figure shows that the impact strength of the ceramic bearings is almost equal to the static load strength, which means the bearings possess sufficient impact strength.

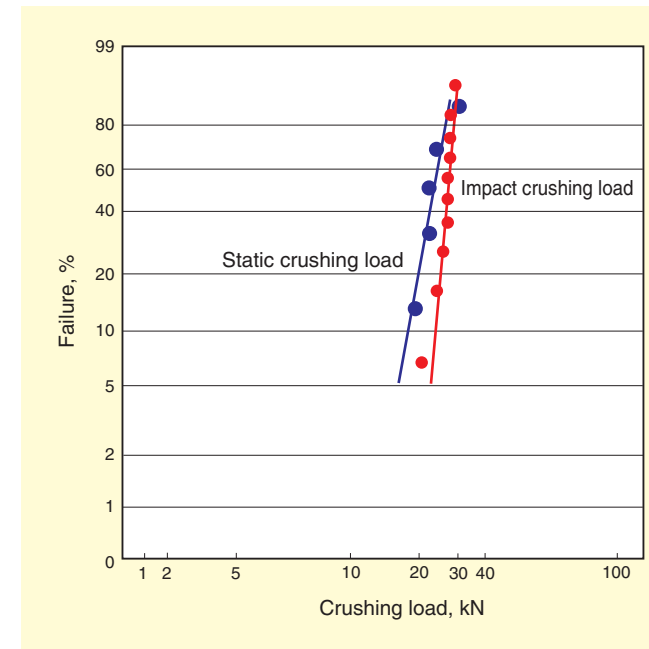
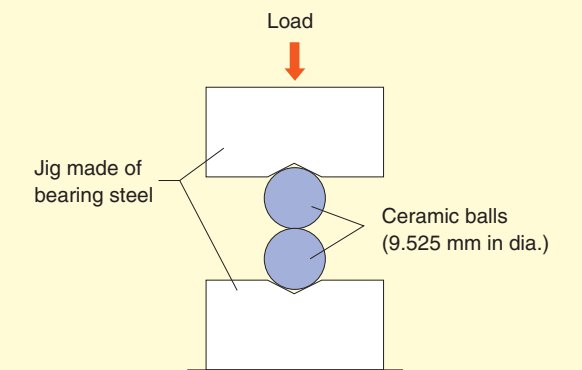

Fig. 1-9 Comparison of static load and impact load that crush ceramic balls

• Static crushing test



• Impact crushing test

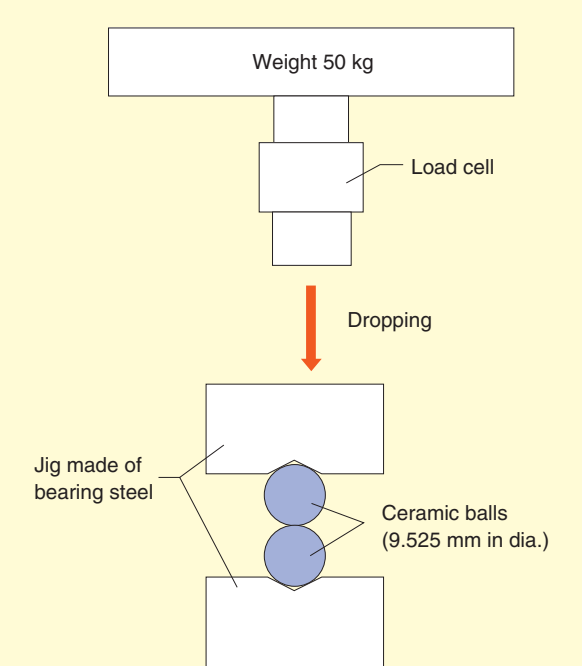

Fig. 1-10 Ceramic ball crushing test method

4) Fitting of ceramic bearings

When using ceramic bearings, it should be noted that ceramic materials are largely different from steel materials in the coefficient of linear expansion. Attention should therefore be paid to fitting stresses and temperature rises.

The following are the results of evaluating the fitting of a Ceramic Bearing on a stainless steel shaft.

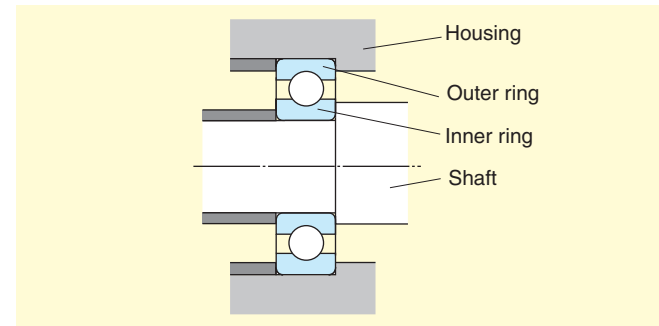

Fig. 1-11 Bearing fitting

Maximum stress produced by fitting

Table 1-6 shows the results of a static strength test conducted on a ceramic ring fitted on a stainless steel shaft. Table 1-7 shows the results of a dynamic strength test (running test) conducted on a ceramic ring fitted on a stainless steel shaft.

Based on the results of these tests, JTEKT makes it a rule for the maximum stress produced by interference to be no greater than 150 MPa when a ceramic inner ring is fitted on a stainless steel shaft.

Consult JTEKT for applications requiring tighter fitting.

Table 1-6 Typical results of static strength test on ceramic bearing shaft fitting

	Interference, L ₁₀ μm	Ring's fracture stress MPa
Solid shaft	50	399
Hollow shaft	68	332

Table 1-7 Typical results of dynamic strength test on ceramic bearing shaft fitting

	Max. allowable interference μm	Max. allowable stress for ring MPa
Solid shaft	31	243
Hollow shaft	43	204

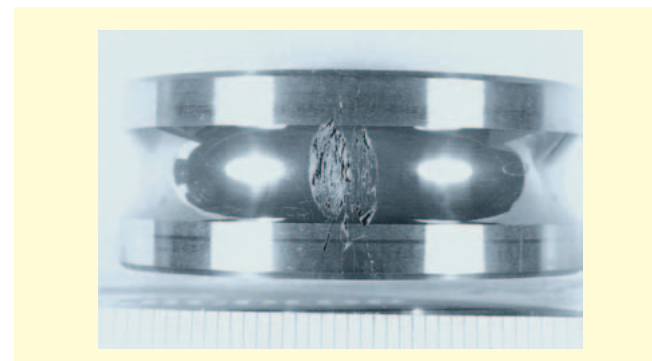

Fig. 1-12 Ceramic inner ring damaged by dynamic strength test

Influence of temperature

During operation, bearing temperature exceeds the ambient temperature. When a ceramic bearing is operated on a stainless steel shaft or in a stainless steel housing, the interference with the shaft increases due to the difference in linear expansion coefficient while the interference with the housing decreases. (When the outer ring is loose-fitted, the clearance increases.)

To determine the class of fit for a ceramic bearing, the maximum temperature during operation should be assessed carefully.

The maximum stress generated on the inner ring due to the interference with the shaft can be determined from the following equation:

$$\sigma = P_m \cdot \frac{D_i^2 + d^2}{D_i^2 - d^2}$$

$$P_m = \Delta_{def} \left[\frac{d}{E_B} \left(\frac{D_i^2 + d^2}{D_i^2 - d^2} + \nu_B \right) + \frac{d}{E_S} \left(\frac{d^2 + d_0^2}{d^2 - d_0^2} - \nu_S \right) \right]^{-1}$$

- σ : Maximum circumferential stress to interference (MPa)
- P_m : Pressure of contact on fitting surface (MPa)
- d, D_i : Inner ring bore diameter and outside diameter (mm)
- Δ_{def} : Effective interference of inner ring (mm)
- d₀ : Bore diameter of hollow shaft (mm)
- E_B, ν_B : Bearing's modulus of longitudinal elasticity and Poisson's ratio (MPa)
- E_S, ν_S : Shaft's modulus of longitudinal elasticity and Poisson's ratio (MPa)

1-2 Special Steel Bearings

Table 1-8 lists the typical special steels used to produce the bearing rings and rolling elements of EXSEV Bearings.

Table 1-8 Characteristics of the typical special steels used for EXSEV Bearings

⊙: Superior, ○: Good

	Hardness HRC	Modulus of longitudinal elasticity GPa	Coefficient of linear expansion ×10 ⁻⁶ K ⁻¹	Load carrying capability	Applications
High carbon chromium bearing steel SUJ2	61	208	12.5	⊙	Hybrid Ceramic Bearings for insulation, etc.
Martensitic stainless steel SUS440C	60	208	10.5	⊙	Clean environments and vacuum environments
Precipitation hardening stainless steel SUS630	40	196	11.0	○	Corrosive environments
High speed tool steel M50	61	207	10.6	⊙	High temperature environments
High speed tool steel SKH4	64	207	12.0	⊙	High temperature environments
Non-magnetic stainless steel	43	200	18.0	○	Magnetic field environments

1) Bearings for use in clean and/or vacuum environments

The rings and rolling elements of conventional bearings are made of high carbon chromium bearing steel (JIS SUJ2), which is resistant to rolling fatigue. However, due to a relatively low corrosion resistance, this steel requires application of anticorrosive oil or other suitable rust preventive measure.

Applying anticorrosive oil to bearings is not favorable for use in a clean and / or vacuum environment, due to the possibility of contamination. Accordingly, EXSEV Bearings use martensitic stainless steel (JIS SUS440C), which is highly corrosion resistant, as a standard material for use in a clean environment.

2) Bearings for use in corrosive environments

For a highly corrosive environment where the SUS440C is not enough to prevent corrosion, precipitation hardening stainless steel (JIS SUS630) is used. However, SUS630 has a hardness of 40 HRC, which is inferior to other materials in load carrying capability and rolling fatigue strength.

3) Bearings for use in high temperature environments

Fig. 1-13 shows the high temperature hardness of various materials. SUS440C has a hardness of 55 HRC at 300°C, which means it can be used in a high temperature environment of up to approximately 300°C. In an environment heated in excess of 300°C, high speed tool steel (JIS SKH4, AISI M50, etc.) should be used.

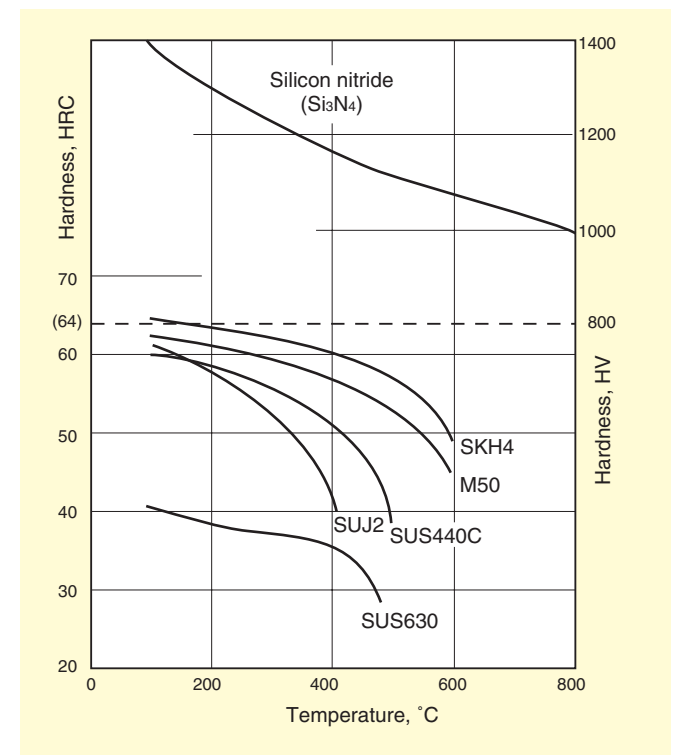

Fig. 1-13 High temperature hardness of various bearing materials

2 Lubricants for EXSEV Bearings

Bearing performance depends on lubrication; it is no exaggeration to say that lubrication determines the service life of bearings. Grease or a solid lubricant is properly used to lubricate the EXSEV bearings.

Compared with solid lubricants, grease is superior for the high speed performance, load carrying capability, and service life of bearings. Therefore, it is recommended to use grease as much as possible.

Grease cannot be used for some application in an ultrahigh vacuum, high temperature, or clean environment. In an application where oil evaporation from grease is unacceptable, solid lubricants should be used.

2-1 Grease

1) High temperature, vacuum or clean environments

Fluorinated greases are known as useful for high temperature applications. Its base oil is perfluoropolyether (PFPE) and its thickener is polytetrafluoroethylene (PTFE).

Fluorinated grease has a low evaporation pressure, and can be used in a vacuum environment of approximately 10^{-5} Pa at room temperature. Another advantage of this grease is low particle emissions, and is applicable in a clean environment. Owing to these excellent characteristics, fluorinated grease is used as the standard grease for the EXSEV Bearings.

2) High vacuum environments

Fluorinated greases are classified according to whether the base oil includes an acetal bond (-O-CF₂-O-) and whether side chains are included (Table 2-1).

Note that when a fluorinated grease is used in a vacuum, these differences in molecular structure may cause the molecular chains to be disconnected and decompose, resulting in a difference in the amount of gas emissions in the vacuum.

For the PFPE of the three greases listed in Table 2-1, Fig. 2-1 shows the results of gas emissions evaluation, using four ball type vacuum test equipment.

As can be seen Fig. 2-1, oil A, which originally has the acetal structure, apparently emits a great amount of oxide components, such as CF₂O⁺, C₂F₃O⁺ and C₂F₅O⁺, which are attributed to the decomposition of the acetal structure. It emits a greater amount of gas than other oils.

As the standard grease for the EXSEV Bearings, JTEKT uses fluorinated grease containing oil B or PFPE, whose molecular chains are not easily torn off.

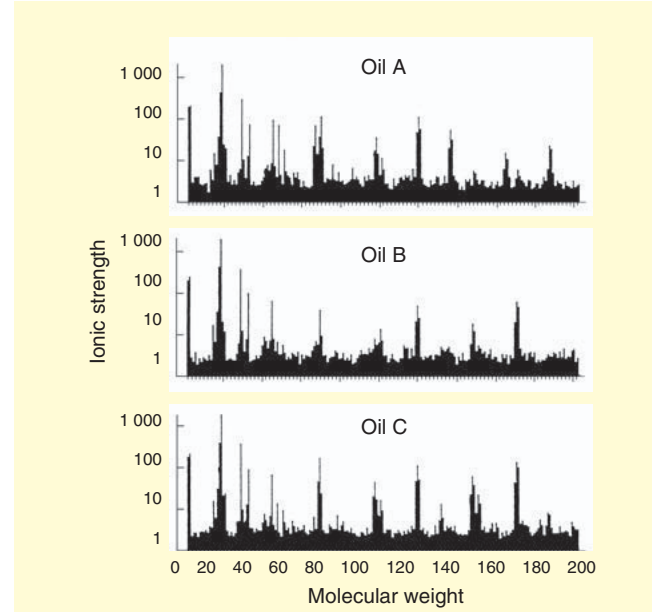

Fig. 2-1 Differences in gas emissions from PFPE

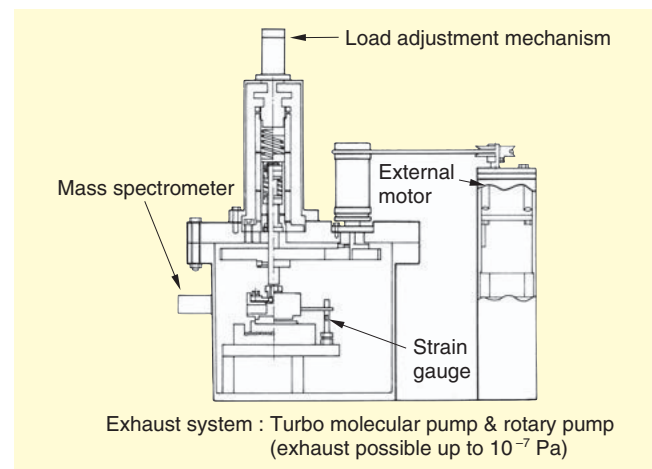

Fig. 2-2 Four ball type vacuum test equipment

Table 2-1 Tested PFPEs and their characteristics

Oil	Molecular structure	Viscosity, 20°C mm ² /s	Mean molecular weight	Vapor pressure, 20°C Pa
A	CF ₃ - (OCF ₂ CF ₂) _p - (OCF ₂) _q - OCF ₃	255	9 500	4 × 10 ⁻¹⁰
B	F - (CF ₂ CF ₂ CF ₂ O) _n - CF ₂ CF ₃	500	8 400	7 × 10 ⁻⁹
C	F - (CFCF ₂ O) _m - CF ₂ CF ₃	2 700	11 000	4 × 10 ⁻¹²

2-2 Solid Lubricants

In an environment where oil and grease cannot be used, a solid lubricant is used to lubricate bearings.

Solid lubricants can roughly be classified into soft metals, layer lattice materials, and polymeric materials.

Table 2-2 shows the characteristics of major solid lubricants used for the EXSEV Bearings, along with the major applications where the individual solid lubricants are used.

1) Soft metals

Soft metals, such as silver (Ag) and lead (Pb), are coated on balls by the ion plating method (refer to Fig. 2-3). These lubricants are effective for use in ultrahigh vacuum environments where gas emissions from bearings should be avoided.

Silver coated components require careful handling because silver is susceptible to oxidation and durability deteriorates rapidly once oxidized. Lead is seldom used as a lubricant because it is hostile to the environment.

2) Layer lattice materials

Among layer lattice materials, molybdenum disulfide (MoS₂) is coated to the cage and bearing rings, or is used as an additive for composite materials, while tungsten disulfide (WS₂) is not used as a coating material but used only as an additive for composite materials (refer to Fig. 2-4).

These lubricants are superior to polymeric materials in heat resistance and load carrying capability, and are used for high temperature applications or applications where a large load carrying capability is required.

Layer lattice materials should not be used in a clean environment because they emit an excessive amount of particles.

3) Polymeric materials

Polymeric materials are coated to the cage and/or bearing rings. They are also used to make cages (refer to Fig. 2-5).

Polymeric materials are suitable for applications where cleanliness is critical or the environment is corrosive. Because they are relatively independent of ambient conditions, they are suitable for applications where bearings are repeatedly exposed to atmospheric air and a vacuum.



Fig. 2-3 Balls coated with silver ion plating

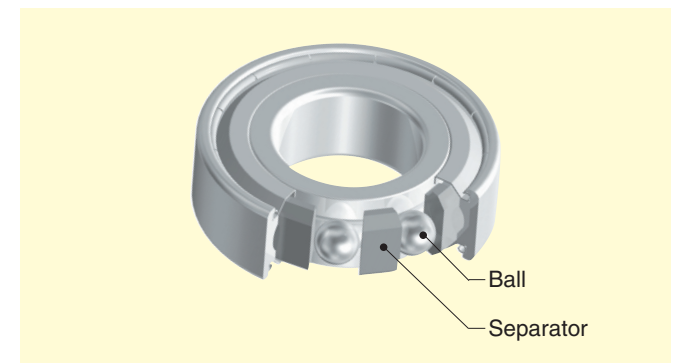

Fig. 2-4 Separator including tungsten disulfide

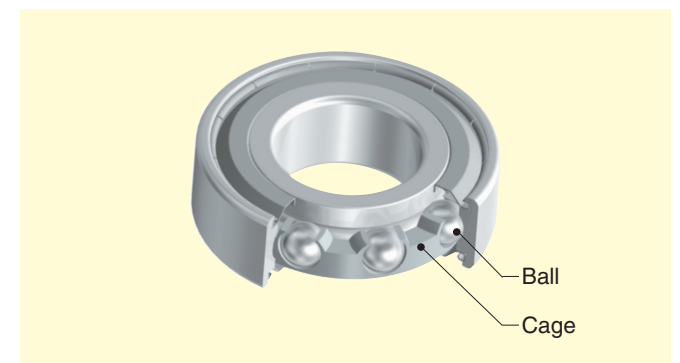

Fig. 2-5 Cage made from fluorocarbon resin

Table 2-2 Characteristics of major solid lubricants used for EXSEV Bearings

◎ : Superior, ○ : Good, △ : Acceptable

Solid lubricant	Thermal stability, °C		Coefficient of friction		Load capacity MPa	Particle emissions	Gas emissions	Applications	
	Atmospheric air	Vacuum	Atmospheric air	Vacuum					
Soft metals	Silver (Ag)	-	600 or higher	-	0.2 to 0.3	2 500 max.	△	◎	Ultrahigh vacuum environments
	Lead (Pb)	-	300 or higher	0.05 to 0.5	0.1 to 0.15	2 500 max.	△	◎	
Layer lattice materials	Molybdenum disulfide (MoS ₂)	350	400 or higher	0.01 to 0.25	0.001 to 0.25	2 000 max.	△	○	Vacuum environments, High temperature environments
	Tungsten disulfide (WS ₂)	425	400 or higher	0.05 to 0.28	0.01 to 0.2	2 500 max.	△	○	
	Graphite (C)	500	-	0.05 to 0.3	0.4 to 1.0	2 000 max.	△	○	
Polymeric materials	Polytetrafluoroethylene (PTFE)	260	200	0.04 to 0.2	0.04 to 0.2	1 000 max.	◎	△	Clean, vacuum, and/or corrosive environments
	Polyimide (PI)	300	200 or higher	0.05 to 0.6	0.05 to 0.6	1 000 max.	○	△	

4) Service life of solid lubricants

Bearings lubricated with a solid lubricant can provide stable running performance as long as the lubricant is supplied continuously. When the lubricant is used up, the metal components become in contact with each other, rapidly increasing running torque and reducing the service life of the bearing. The service life of bearings is greatly influenced by the operating conditions. As a consequence, it is not always possible to accurately estimate the service life of bearings lubricated with solid lubricant because of the variations in operating conditions.

When a solid lubricant is used to lubricate a bearing, the bearing is generally used under a relatively light load, such as 5% or less of the basic dynamic load rating. Based on the results of various experiments under the above mentioned operating conditions, JTEKT provides the following experimental equation to enable an estimation of the service life of a deep groove ball bearing lubricated with a solid lubricant.

• Polymeric materials

The average service life of clean pro coated bearings can be estimated by the following equation:

$$L_{av} = b_2 \cdot \left(\frac{C_r \times 0.85}{P_r} \right)^q \times 0.016667/n$$

Where,

- L_{av} : Average life, h
- b_2 : Lubrication factor
 $b_2 = 42$
- C_r : Basic dynamic load rating, N
- P_r : Dynamic equivalent radial load, N
- q : Exponential coefficient, $q = 3$
- n : Rotational speed, min^{-1}

• Layer lattice materials

The average service life of the EXSEV Bearings whose cage is coated with molybdenum disulfide (MO Bearings) can also be estimated by the above equation, supposing that b_2 equals to 6.

• Soft metal materials

The average service life of the EXSEV Bearing whose balls are silver ion plated (MG Bearing) can be estimated using the following equation:

$$L_{vh} = b_1 \cdot b_2 \cdot b_3 \left(\frac{C_r}{13 \times P_r} \right)^q \times 16\,667/n$$

Where,

- L_{vh} : 90% reliability service life, h
- C_r : Basic dynamic load rating, N
- P_r : Dynamic equivalent radial load, N
- q : Exponential coefficient, $q = 1$
- n : Rotational speed, min^{-1} ($10 \leq n \leq 10\,000$)
- b_1 : Speed factor
 $b_1 = 1.5 \times 10^{-3} n + 1$
- b_2 : Lubrication factor
 $b_2 = 1$
- b_3 : Ambient pressure/temperature factor
 $b_3 = 1$ (at 10^{-3} Pa and room temperature)

3 How to Select EXSEV Bearings

3-1 Clean Environments

In a clean environment, bearings made of high carbon chromium bearing steel applied with rust preventive oil cannot be used. Accordingly, stainless steel bearings are used without applying rust preventive oil. A low particle emission type lubricant should be used for these bearings.

Fig. 3-1 shows an EXSEV Bearing selection chart on the basis of the cleanliness class and temperature of the environment. In this chart, each numerical value has a margin.

The amounts of particle emissions from bearings differ depending on operating conditions such as temperature, load and rotational speed. Please consult JTEKT for applications who's operating conditions are near the bearing applicability divisions specified in Fig. 3-1.

Table 3-1 compares the particle emissions of various lubricants provided for major EXSEV Bearings.

For an unlubricated EXSEV Bearing, more than 3 million particles are found for every 20 hours. When silver or molybdenum disulfide is used as a lubricant, 10 000 or more particles are emitted, indicating that neither is suitable for clean environments.

Bearings using a fluorine polymer are low in particle emissions and suitable for use in clean environments.

Bearings lubricated with a Clean Pro coating or fluorinated grease are also useful in clean environments because they are low in particle emissions.

Fluorinated grease is superior to solid lubricants in load carrying capability and high speed operation. This grease can be used in applications where a slight amount of scattering of fluorinated oil is acceptable.

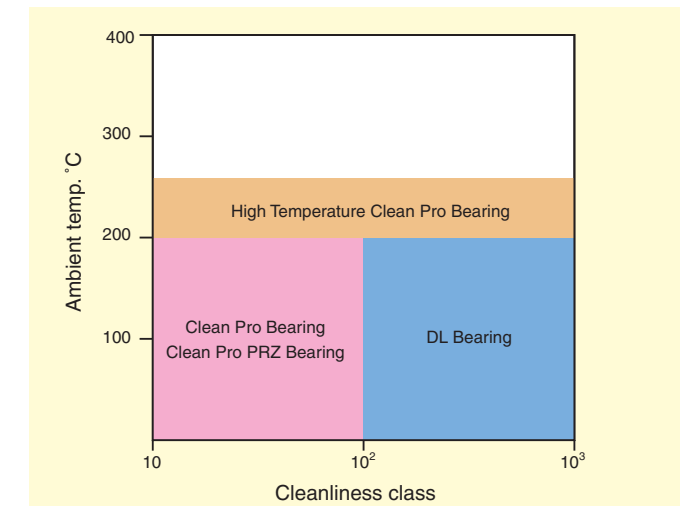

Fig. 3-1 EXSEV Bearings suitable for clean environments

Table 3-1 Particle emissions from major EXSEV Bearings

Bearing material composition			Lubrication		Number of emitted particles during 20-hour test duration	
Bearing rings	Balls	Cage	Lubricated component	Lubricant		
SUS440C	SUS440C	SUS304	—	(None)	3 641 252	
	Silicon nitride	SUS304			10 348	
	SUS440C	SUS440C	SUS304	Balls	Silver ion plating	23 218
				Cage	Baking of molybdenum disulfide	434 452
				Cage	Baking of PTFE	42
			Cage	Fluorine polymer	38	
	SUS304	SUS304	Whole component surfaces	Clean Pro coating	7	
				Fluorinated grease	11	

Test conditions
 Bearing number: ML6012
 ($\phi 6 \times \phi 12 \times 3\text{mm}$)
 Rotational speed: 200 min^{-1}
 Radial load: 2.9 N per two bearings
 Particle size: $0.3 \mu\text{m}$ or greater

For the properties of the EXSEV Bearings shown in Fig. 3-1, refer to the pages listed below.

Fluorinated grease	Polymeric materials
DL Bearing35	Clean Pro Bearing29
	High Temperature Clean Pro Bearing31
	Clean Pro PRZ Bearing33

3 - 2 Vacuum Environments

Bearing materials

Outer/inner rings and balls of the bearings for use in a vacuum environment are usually made of martensitic stainless steel (SUS440C). For the bearings requiring corrosion resistance, precipitation hardening stainless steel (SUS630) is used. When high temperature resistance is required, high speed tool steel (SKH4, M50, etc.) can be used. For a special operating condition, ceramic having excellent heat/corrosion resistance may be used.

Lubricants

A bearing used in an ordinary vacuum chamber is repeatedly exposed to atmospheric air and vacuum. There is no rolling bearing lubricant that is effective for use under such a wide pressure range. The lubricant should optimally be selected in consideration of principal ambient pressure and temperature as well as required cleanliness and corrosion resistance when necessary.

1) When cleanliness is not critical:

Fig. 3-2 shows the EXSEV Bearings that are suitable for vacuum applications that do not require cleanliness.

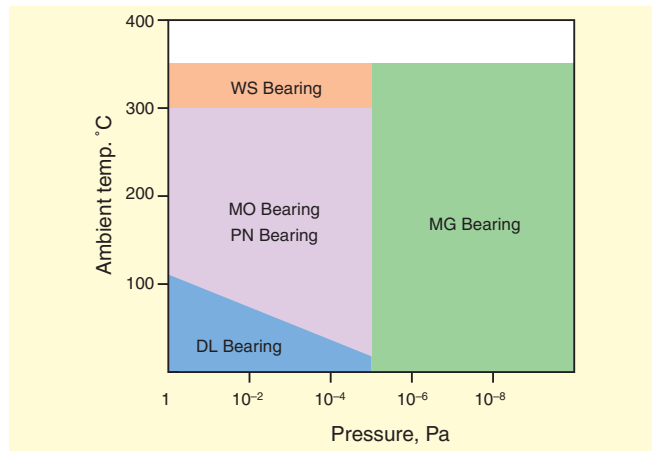

Fig. 3-2 EXSEV Bearings useful for vacuum applications where cleanliness is not critical

When the ambient temperature is near normal room temperature and vacuum is 10^{-5} Pa or less, fluorinated grease is used for lubrication. However, since the fluorinated oil contained in the grease gradually begins to evaporates, a solid lubricant should be used in applications where oil scattering should not occur.

In an ultrahigh vacuum environment with pressure lower than 10^{-5} Pa, gas emissions from bearings may pose a problem. For this pressure range, MG Bearings lubricated with silver, a soft metal lubricant, should be used.

2) When cleanliness is critical:

When bearings should be clean, solid lubricants such as soft metal materials and layer lattice materials cannot be used because of excessive particle emissions. In such a case, a polymeric material or fluorinated grease is used.

Figs. 3-3 and 3-4 show the EXSEV Bearings applicable for vacuum environments with cleanliness classes 100 and 10, respectively.

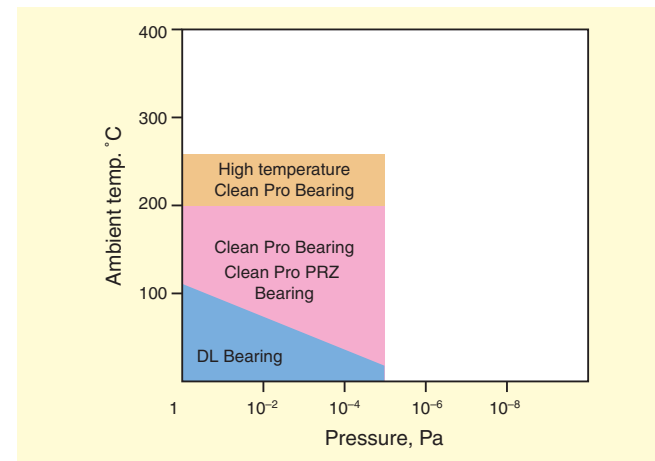

Fig. 3-3 EXSEV Bearings applicable for cleanliness class 100

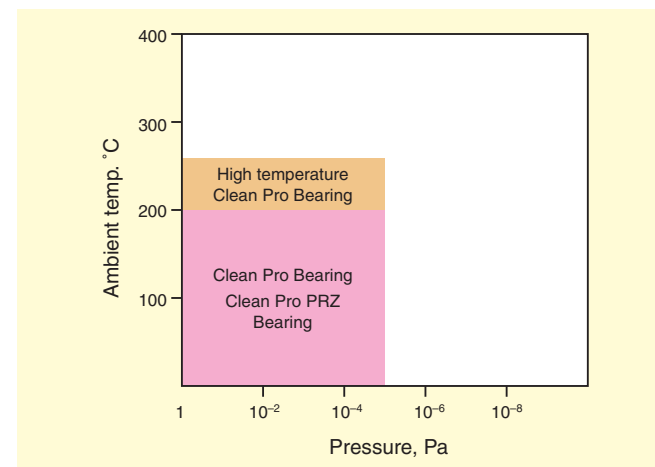

Fig. 3-4 EXSEV Bearings applicable for cleanliness class 10

3 - 3 High Temperature Environments

Bearing materials

Fig. 3-5 shows bearing materials for high temperature applications.

SUS440C can withstand temperatures up to approximately 300°C.

In the range from 300°C to approximately 500°C, High Temperature Hybrid Ceramic Bearings, whose bearing rings are made of highly heat resistant high speed tool steel (SKH4 or M50) and rolling elements made of ceramic, should be used.

In a high temperature environment in excess of 500°C, full ceramic bearings should be used.

Lubricants

Fig. 3-5 shows lubricants for high temperature applications. In a temperature range of up to approximately 200°C, fluorinated grease can be used. At temperatures over 200°C, a layer lattice material should be used.

Because all layer lattice materials emit a large amount of particles, they are not suitable for applications where cleanliness is required. Graphite cannot be used in a vacuum environment because it does not serve as a lubricant in a vacuum.

In a high temperature environment over 500°C, there is no lubricant that can work perfectly. Unlubricated full ceramic bearings are used for such a high temperature application.

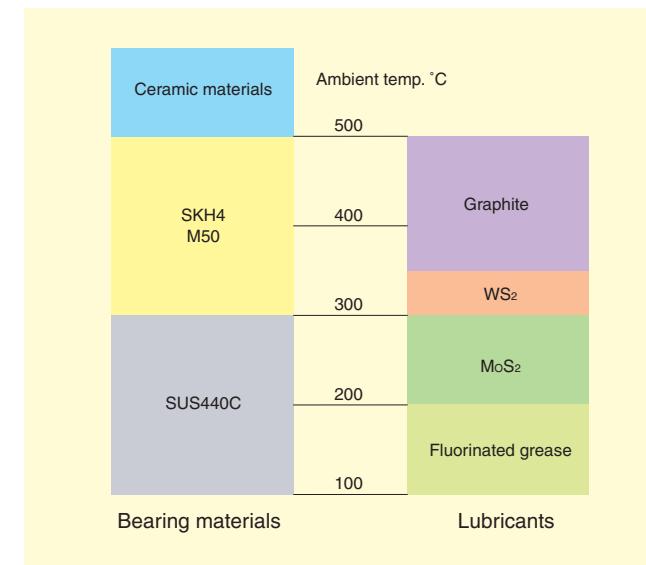

Fig. 3-5 Bearing materials and lubricants for high temperature applications

Fig. 3-6 shows the EXSEV Bearings useful for high temperature applications.

The temperatures shown in the figure are approximate. When the operating temperature of your application is near a temperature division specified in this figure, consult JTEKT.

If a bearing is exposed to a high temperature in a clean or vacuum environment, please refer to the sections entitled "Clean Environments" or "Vacuum Environments".

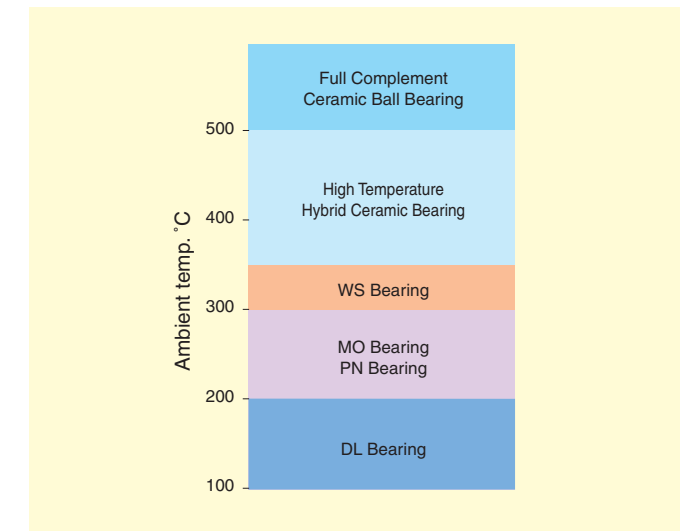

Fig. 3-6 EXSEV Bearing applicable for high temperature environments

For the properties of the individual EXSEV Bearings shown in the figures, refer to the applicable pages shown below:

Fluorinated grease

DL Bearing35

Polymeric materials

Clean Pro Bearing29
High Temperature Clean Pro Bearing31
Clean Pro PRZ Bearing33

Layer lattice materials

PN Bearing37
WS Bearing39
MO Bearing41
High Temperature Hybrid Ceramic Bearing45

Soft metal materials

MG Bearing43

No lubrication

Full Complement Ceramic Ball Bearing47

3 - 4 Corrosive Environments

1) Corrosion resistance of special steels

Table 3-2 shows the corrosion resistance of the special steels used for the EXSEV Bearings to major corrosive solutions.

In stainless steels, SUS630 is superior to SUS440C in corrosion resistance. However, in such a highly corrosive solution as an acid or alkaline solution, or if the solution must be kept free from rust, these special steels cannot be used.

● **Table 3-2 Corrosion resistance of special steels**

Solution	Concentration %	SUJ2	SUS440C	SUS630
Hydrochloric acid	1	×	△	○
	10	×	×	×
Sulfuric acid	1	×	○	◎
	10	×	△	○
Nitric acid	20	×	○	◎
Seawater	—	×	○	◎
Water	—	×	◎	◎

Temperature 25°C
 Corrosion rate ◎ : Up to 0.125 mm/year ○ : Over 0.125 to 0.5 mm/year
 △ : Over 0.5 to 1.25 mm/year × : Over 1.25 mm/year

● **Table 3-3 Corrosion resistance of ceramic materials**

Ceramic materials	Silicon nitride (standard) Si ₃ N ₄	Corrosion resistant silicon nitride Si ₃ N ₄	Zirconia ZrO ₂	Silicon Carbide SiC
Hydrochloric acid	△	○	○	◎
Nitric acid	△	○	○	◎
Sulfuric acid	△	○	○	◎
Phosphoric acid	○	○	○	◎
Fluorine acid	△	△	×	◎
Sodium hydroxide	△	△	○	△
Potassium hydroxide	△	△	△	△
Sodium carbonate	△	△	△	△
Sodium nitrate	△	△	△	△
Water and saltwater	◎	◎	◎	◎

Note) The corrosive natures of individual solutions differ largely depending on the concentration and temperature. Note that mixing two or more chemicals may increase the corrosivity.

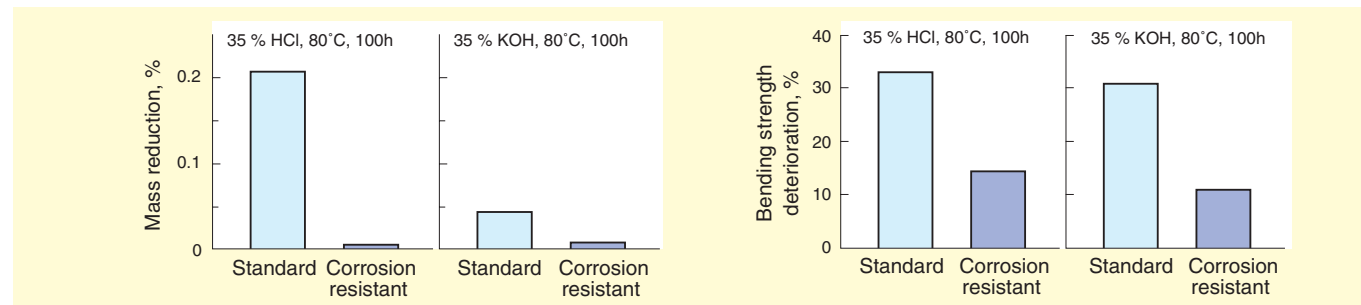

Fig. 3-7 Anticorrosive performance of corrosion resistant silicon nitride

2) Corrosion resistance of ceramic materials

Table 3-3 shows the corrosion resistance of ceramic materials. Silicon nitride, which is used as the standard material of the ceramic bearings, is excellent in corrosion resistance. However, it may develop corrosion in a highly corrosive chemical, a high temperature, or other highly corrosive ambient condition.

There are two types of ceramic corrosion: One is the corrosion of the alumina-yttria system sintering aid (Al₂O₃ - Y₂O₃), which is used to bake ceramic materials. To avoid this type of corrosion, corrosion resistant silicon nitride treated with a spinel sintering aid (MgAl₂O₄) should be used. Fig. 3-7 shows the mass reduction and bending strength deterioration of corrosion resistant silicon nitride dipped in an acid or alkaline solution for a given period of time.

The other type of corrosion is the corrosion of the silicon nitride itself. For use in a highly corrosive solution, bearings made of zirconia (ZrO₂) or silicon carbide (SiC) may be effective.

To select a ceramic bearing for use in a highly corrosive environment, its corrosion resistance to the specific condition should be carefully examined.

3) Service life of corrosion resistant bearings

Table 3-4 lists the bearings suitable for applications requiring corrosion resistance, along with their major applications.

● **Table 3-4 Typical corrosion resistant EXSEV Bearings**

	Applications	Bearing Materials		Page
		Bearing Rings	Balls	
Corrosion Resistant Hybrid Ceramic Bearing	In water, alkaline environment and reactive gas	SUS630	Silicon nitride	51
Ceramic Bearing	In a slightly acidic environment, alkaline environment and reactive gas	Silicon nitride	Silicon nitride	53
Corrosion Resistant Ceramic Bearing	In a strongly acidic environment, strongly alkaline environment and reactive gas	Corrosion resistant silicon nitride	Corrosion resistant silicon nitride	55
High Corrosion Resistant Ceramic Bearing	In a strongly acidic environment, strongly alkaline environment and corrosive gas	Silicon carbide	Silicon carbide	57

When EXSEV Bearings are operated in a solution, the solution serves as a lubricant. This means the solution is closely associated with the service life of the bearings. Fig. 3-8 shows the service life evaluation results for three types of EXSEV Bearings under water.

The Ceramic Bearings terminate their service life due to the flaking on the bearing ring or ball surfaces.

In case of the Hybrid Ceramic Bearings, ceramic balls do not develop flaking or wear. Their service life ends due to wear attributed to the minute corrosion of stainless steel bearing rings.

When bearings are used in a solution whose lubrication performance is not enough, such as in water, it is important to evaluate in advance the susceptibility of the bearings to corrosion and the relationship between the bearing load and wear in the solution.

SUS440C has a longer service life than SUS630; however, the former steel is not suitable for use in water because it may rust and cause contamination.

Ceramic Bearings may develop wear at an early stage of use depending on the characteristics of the solution, temperature, and load. Please contact JTEKT before using Ceramic Bearings in solutions.

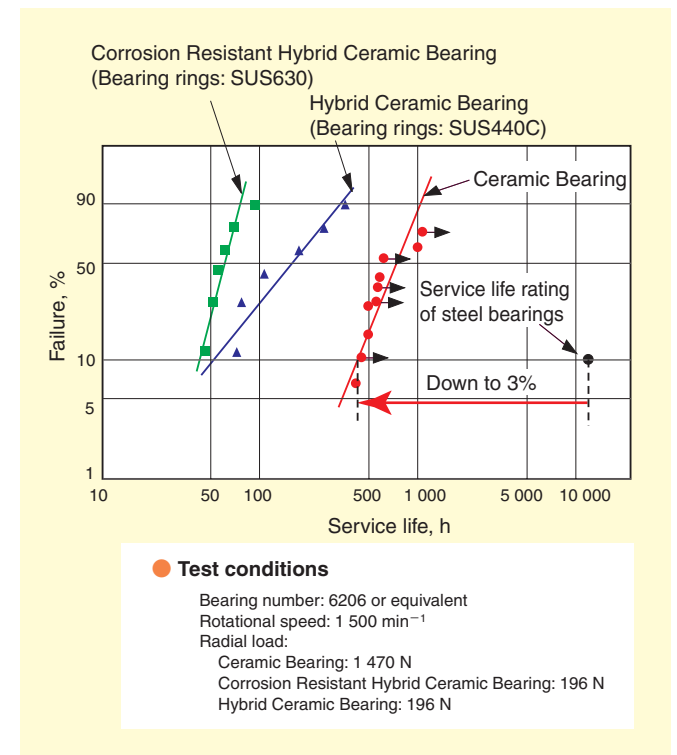

Fig. 3-8 Comparison in underwater service life of EXSEV Bearings

4 EXSEV Bearings with Special Characteristics

4-1 Non-magnetic Bearings

Bearings may be exposed to magnetic fields in some applications, including equipment associated with super conductivity, semiconductor production facilities and medical examination facilities. If steel bearings are used for such applications, the running torque may fluctuate or the magnetic field may be disturbed. Non-magnetic bearings should be used for such applications. As a non-magnetic material for such bearings, beryllium copper has conventionally been used. However the use of beryllium copper should be avoided since it contains beryllium, a substance of environmental concern.

For such applications, JTEKT supplies Hybrid Ceramic Bearings, whose rings are made of non-magnetic stainless steel and rolling elements are made of a ceramic material, or the full ceramic bearings.

Table 4-1 Non-magnetic bearings and relative permeability

	Relative permeability	Page
Non-magnetic Hybrid Ceramic Bearings	1.01 or lower	59
Ceramic Bearings	1.001 or lower	53
(Ref.) Beryllium copper	1.001 or lower	—

Fig. 4-1 shows a rolling fatigue strength evaluation result for various non-magnetic materials. As can be seen from the figure, non-magnetic stainless steel is superior to beryllium copper in rolling fatigue strength.

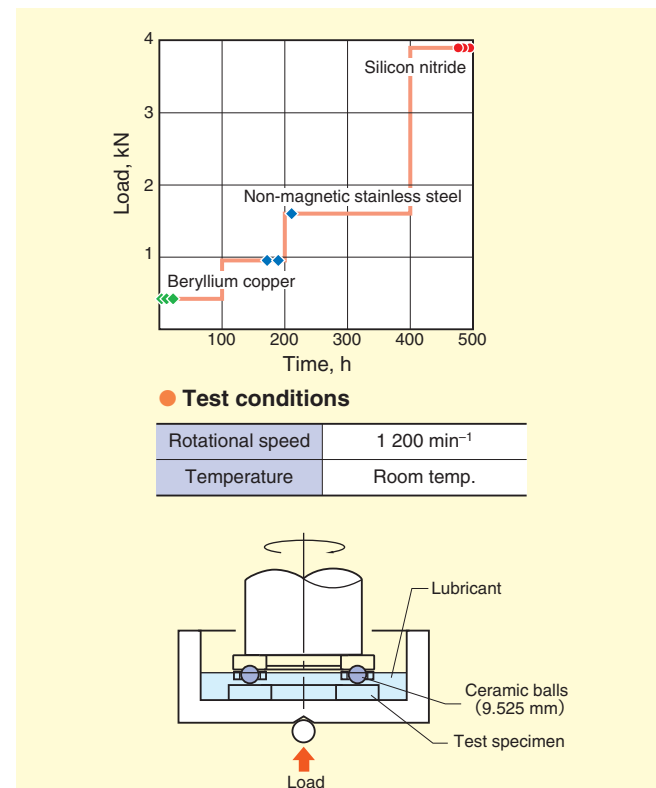

Fig. 4-1 Comparison of non-magnetic materials in rolling fatigue strength

4-2 Insulating Bearings

A cause of bearing failure in motors or generators is electric pitting. Electric pitting occurs when a surface in rolling contact is locally molten due to sparks produced over the very thin lubricating oil film on the surface when electricity passes through the bearing in operation.

Electric pitting appears as a series of pits or a series of ridges on the surface in rolling contact.

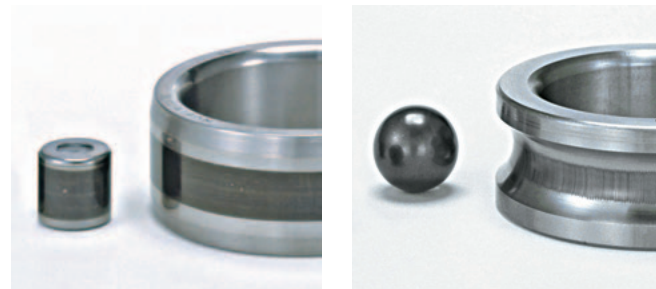

Fig. 4-2 Electric pitting generated on general purpose bearings (pits on the left and ridges on the right)

To avoid such pitting, a bypass is provided to ensure that no electric current passes through the bearing. Another method is to use an insulating bearing that can block electric current.

Since ceramic materials exhibit an excellent insulation performance, Hybrid Ceramic Bearings consisting of ceramic rolling elements can be used as insulating bearings.

Hybrid Ceramic Bearings prevent electric pitting, also reduce bearing temperature rise, and lengthen grease service life. For these reasons, Hybrid Ceramic Bearings assure long term maintenance free operation and high speed equipment operation.



Fig. 4-3 Insulating bearings (Hybrid Ceramic Bearings)

4-3 High Speed Bearings

Hybrid Ceramic Bearings, whose rolling elements are made of a ceramic material with a density lower than that of bearing steel, are most suitable for high speed applications. This is because reduced mass of rolling elements suppresses the centrifugal force of the rolling elements, as well as slippage attributable to the gyro-moment, when the bearings are in operation.

Thanks to their superior high speed performance, Hybrid Ceramic Bearings are used in turbochargers and on machine tool spindles.

Power losses at high speed

Fig. 4-4 compares power losses between the Hybrid Ceramic Bearings and steel bearings.

When compared to steel bearings, the Hybrid Ceramic Bearings lose smaller power during high speed operation. The power loss decreases with increasing rotational speed.

The Hybrid Ceramic Bearings also have superior antiseizure characteristics, which means that they consume smaller amount of lubrication oil and thereby reduce rolling resistance (power loss).

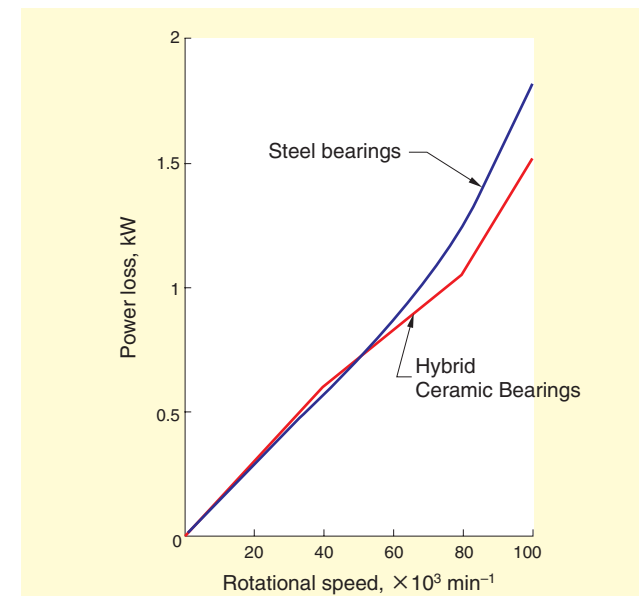

	Hybrid Ceramic Bearings	Steel bearings
Bearing rings	High speed tool steel (M50)	
Balls	Material	Ceramic (Si ₃ N ₄)
	Dia.	6.35 mm
	Number of balls	9
Cage	Polyimide resin	

Condition	Specification
Axial load	200 N
Rotational speed (max.)	100 000 min ⁻¹
Lubricating oil	AeroShell Turbine Oil 500
Ambient temperature	Room temp.

Fig. 4-4 Comparison in power loss between Hybrid Ceramic Bearings and steel bearings

Seizure limit at high speed

Fig. 4-5 shows the seizure limits of Hybrid Ceramic Bearings and steel bearings. The limits were measured by gradually reducing lubricating oil feed rate.

Compared with general purpose steel bearings, Hybrid Ceramic Bearings consume smaller amount of lubricating oil under the same speed condition, while they can run at a higher speed under the same lubricating oil feed rate condition.

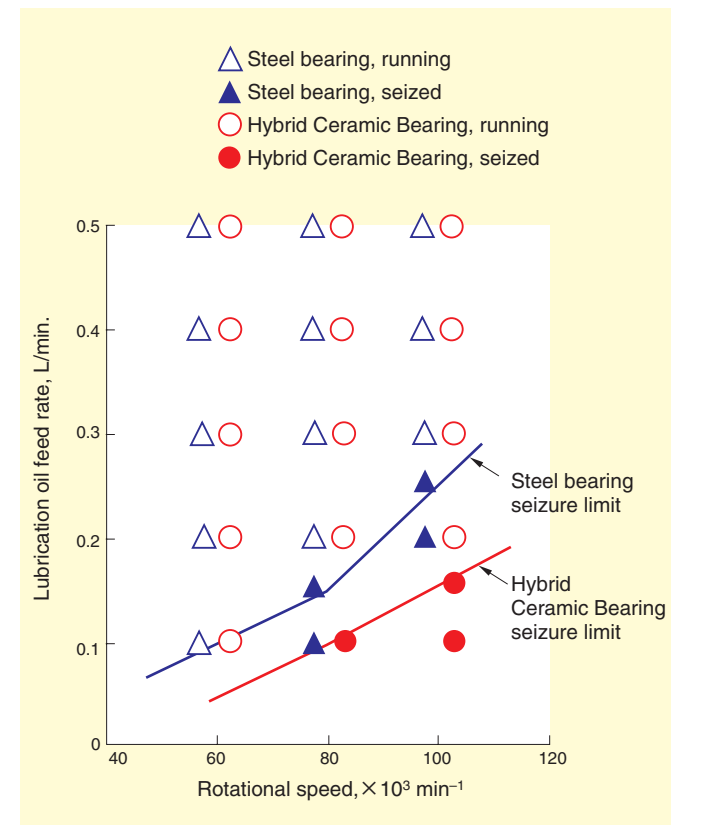

Fig. 4-5 Comparison between Hybrid Ceramic Bearings and steel bearings in seizure limit

2 EXSEV Bearings and Other EXSEV Products

For the use of bearings in an extreme, special environment, identifying the best combination of bearing materials and lubricants according to specific conditions is critical.

This chapter describes the component compositions and features of major EXSEV Bearing varieties.

For other EXSEV Bearings suited to more specialized applications, please consult JTEKT.



1 Ceramic Bearings and EXSEV Bearings:	
Table of Specifications	23
2 Ceramic Bearings and EXSEV Bearings:	
Table of Characteristics	25
3 Radial Ball Bearings	
3-1 Clean Pro Bearing	29
3-2 High Temperature Clean Pro Bearing	31
3-3 Clean Pro PRZ Bearing	33
3-4 DL Bearing	35
3-5 PN Bearing	37
3-6 WS Bearing	39
3-7 MO Bearing	41
3-8 MG Bearing	43
3-9 High Temperature Hybrid Ceramic Bearing	45
3-10 Full Complement Ceramic Ball Bearing	47
3-11 SK Bearing	49
3-12 Corrosion Resistant Hybrid Ceramic Bearing	51
3-13 Ceramic Bearing	53
3-14 Corrosion Resistant Ceramic Bearing	55
3-15 High Corrosion Resistant Ceramic Bearing	57
3-16 Non-magnetic Hybrid Ceramic Bearing	59
3-17 Hybrid Ceramic Bearing	61
4 K Series Full Complement Hybrid Ceramic Ball Bearing	63
5 Linear Motion Bearings	
5-1 Linear Motion Ball Bearings for Use in Extreme Special Environments	65
5-2 Linear Way Bearing Units for Use in Extreme Special Environments	71
5-3 Cross Roller Way Bearing Units for Use in Extreme Special Environments	79
6 High Ability Angular Contact Ball Bearings	85
7 Ceramic Balls	88
8 Tolerance and Internal Clearance of Ceramic Bearings and EXSEV Bearings	
8-1 Tolerance of Radial Ball Bearings	89
8-2 Clearance of Radial Ball Bearings	90
8-3 Tolerance and Internal Clearance of K Series Full Complement Hybrid Ceramic Ball Bearings	90

1 Ceramic Bearings and **EXSEV** Bearings: Table of Specifications

Products		SK Bearing	Clean Pro Bearing	High Temperature Clean Pro Bearing	Clean Pro PRZ Bearing	DL Bearing	PN Bearing	MO Bearing	WS Bearing	MG Bearing		Full Complement Ceramic Ball Bearing (angular contact ball bearing)	Corrosion Resistant Hybrid Ceramic Bearing	Ceramic Bearing	Corrosion Resistant Ceramic Bearing	High Corrosion Resistance Ceramic Bearing	High Temperature Hybrid Ceramic Bearing	Non-magnetic Hybrid Ceramic Bearing	Hybrid Ceramic Bearing	K Series Full Complement Hybrid Ceramic Ball Bearing	
Page		p. 49	p. 29	p. 31	p. 33	p. 35	p. 37	p. 41	p. 39	p. 43		p. 47	p. 51	p. 53	p. 55	p. 57	p. 45	p. 59	p. 61	p. 63	
Bearing No.	Prefix	SK	SE	SE	SE	SV	SE	SE	SE	SE		NC	3NC	NC	NCT	NCZ	3NC	3NC	3NC	3NC	
	Suffix	ST	STPR	STPRB	STPRZ	ST	ST	STMSA7	ST	STMG3		V	MD4	(None)	(None)	(None)	HT4	YH4	(None)	VST-1	
	Cage code	YS	YS	YS	YS	YS	PN	YS	WS	YS		(No cage)	FA	FA	FA	FA	GF	FA	FG	(No cage)	
Outer ring		Martensitic stainless steel										Silicon nitride ceramic (standard)	Precipitation hardening stainless steel	Silicon nitride ceramic (standard)	Silicon nitride ceramic (corrosion resistant)	Silicon carbide ceramic	High speed tool steel	Non-magnetic stainless steel	High carbon chromium bearing steel	Martensitic stainless steel	
Inner ring		Martensitic stainless steel										Silicon nitride ceramic (standard)	Precipitation hardening stainless steel	Silicon nitride ceramic (standard)	Silicon nitride ceramic (corrosion resistant)	Silicon carbide ceramic	High speed tool steel	Non-magnetic stainless steel	High carbon chromium bearing steel	Martensitic stainless steel	
Rolling elements		Martensitic stainless steel										Silicon nitride ceramic (standard)			Silicon nitride ceramic (corrosion resistant)	Silicon carbide ceramic	Silicon nitride ceramic (standard)				
Cage or separator		Austenitic stainless steel					PEEK resin	Austenitic stainless steel	(separator) Composite material including tungsten disulfide	Austenitic stainless steel		(None)	Fluorocarbon resin				Graphite	Fluorocarbon resin	Reinforced polyamide resin	(separators) Martensitic stainless steel	
Shield		Austenitic stainless steel										(None)	Austenitic stainless steel	(None)					Carbon steel	(None)	
Lubrication	Lubricant	KHD grease	Clean pro coating	High temperature clean pro coating	Clean pro PRZ coating	KDL grease	Molybdenum disulfide, etc.	Molybdenum disulfide	Tungsten disulfide	Silver		(None)	Fluorocarbon polymer				Graphite	Fluorocarbon polymer	Grease or oil	KDL grease	
	Component coated with or including lubricant		Entire surface of all components	Raceways and balls			Cage		Separators	Balls		Cage									
Applicable environments		Clean environments										Clean environments						Clean environments	Clean environments		
		Vacuum environments										Vacuum environments						Vacuum environments	Vacuum environments		
		Corrosive environments											Corrosive environments								
			High temperature environments					High temperature environments					High temperature environments						High temperature environments		
													Magnetic field environments	Magnetic field environments					Magnetic field environments		
												Electric field environments						Electric field environments			
																			High speed applications		

2 Ceramic Bearings and EXSEV Bearings: Table of Characteristics (1)

Major Uses	Products	Applicable Environments														Price	Bearing Number ⁽³⁾	(Cage Code)			
		Limiting Speeds		Operating Temp. (°C)								Vacuum (Pa)			Cleanliness (class) ⁽²⁾						
		dn value ⁽¹⁾	Max. (min ⁻¹)	< 120	< 200	< 260	< 300	< 350	< 400	< 500	< 800	Atmospheric air	10 ⁻⁵	10 ⁻¹⁰	10				100	1000	
Clean environment	Vacuum environment	DL Bearing	< 40000	-	→													Low	SV□□□□ZZST	(YS)	
		Clean Pro Bearing	< 10000	1000	→															SE□□□□ZZSTPR	(YS)
		High Temperature Clean Pro Bearing	< 10000	1000	→	→														SE□□□□ZZSTPRB	(YS)
		Clean Pro PRZ Bearing	< 10000	1000	→															SE□□□□ZZSTPRZ	(YS)
		Corrosion Resistant Hybrid Ceramic Bearing	< 10000	1000	→															3NC□□□□ZZMD4	(FA)
		Non-magnetic Hybrid Ceramic Bearing	< 10000	1000	→															3NC□□□□YH4	(FA)
		Ceramic Bearing	< 10000	1000	→														High	NC□□□□	(FA)
	Corrosive environment	Corrosion Resistant Hybrid Ceramic Bearing	< 10000	1000	→														Low	3NC□□□□ZZMD4	(FA)
		Ceramic Bearing	< 10000	1000	→															NC□□□□	(FA)
		Corrosion Resistant Ceramic Bearing	< 10000	1000	→															NCT□□□□	(FA)
		High Corrosion Resistant Ceramic Bearing	< 10000	1000	→														High	NCZ□□□□	(FA)
	High temperature environment	High Temperature Clean Pro Bearing	< 10000	1000	→															SE□□□□ZZSTPRB	(YS)
		Magnetic field environment	Non-magnetic Hybrid Ceramic Bearing	< 10000	1000	→													Low	3NC□□□□YH4	(FA)
	Ceramic Bearing		< 10000	1000	→														High	NC□□□□	(FA)
	Electric field environment	Corrosion Resistant Hybrid Ceramic Bearing	< 10000	1000	→														Low	3NC□□□□ZZMD4	(FA)
Non-magnetic Hybrid Ceramic Bearing		< 10000	1000	→															3NC□□□□YH4	(FA)	
Ceramic Bearing		< 10000	1000	→														High	NC□□□□	(FA)	
Vacuum environment	DL Bearing	< 40000	-	→														Low	SV□□□□ZZST	(YS)	
	PN Bearing	< 10000	1000	→	→														SE□□□□ZZST	(PN)	
	Clean Pro Bearing	< 10000	1000	→															SE□□□□ZZSTPR	(YS)	
	MG Bearing	< 10000	1000	→	→	→													SE□□□□ZZSTMG3	(YS)	
	MO Bearing	< 10000	1000	→	→														SE□□□□ZZSTMSA7	(YS)	
	High Temperature Clean Pro Bearing	< 10000	1000	→															SE□□□□ZZSTPRB	(YS)	
	Clean Pro PRZ Bearing	< 10000	1000	→															SE□□□□ZZSTPRZ	(YS)	
	WS Bearing	< 4000	500	→	→														SE□□□□ZZST	(WS)	
	Corrosion Resistant Hybrid Ceramic Bearing	< 10000	1000	→															3NC□□□□ZZMD4	(FA)	
	Non-magnetic Hybrid Ceramic Bearing	< 10000	1000	→															3NC□□□□YH4	(FA)	
	Ceramic Bearing	< 10000	1000	→															NC□□□□	(FA)	
	Corrosion Resistant Ceramic Bearing	< 10000	1000	→															NCT□□□□	(FA)	
	High Corrosion Resistance Ceramic Bearing	< 10000	1000	→															High	NCZ□□□□	(FA)

(1) dn value: Bearing bore diameter (mm) × Rotational speed (min⁻¹)

(2) The cleanliness classes may vary depending on operating conditions.

(3) The four blank boxes represent the basic number of the bearing. A basic number consists of three or four alphanumeric characters. A bearing number may be used as a convenience in the case of any queries to JTEKT.

Ceramic Bearings and EXSEV Bearings: Table of Characteristics (1)

EXSEV Bearings and Other EXSEV Products

Ceramic Bearings and EXSEV Bearings: Table of Characteristics (2)

Major Uses	Products	Applicable Environments															Price	Bearing Number ⁽³⁾	(Cage Code)	
		Limiting Speeds		Operating Temp. (°C)								Vacuum (Pa)			Cleanliness (class) ⁽²⁾					
		dn value ⁽¹⁾	Max. (min ⁻¹)	< 120	< 200	< 260	< 300	< 350	< 400	< 500	< 800	Atmospheric air	10 ⁻⁵	10 ⁻¹⁰	10	100				1000
Corrosive environment	SK Bearing	Equal to the dn value of normal bearings		→														Low	SK□□□□ZZST	(YS)
	Corrosion Resistant Hybrid Ceramic Bearing	< 10000	1000	→														High	3NC□□□□ZZMD4	(FA)
	Ceramic Bearing	< 10000	1000	→														High	NC□□□□	(FA)
	Full Complement Ceramic Ball Bearing	< 4000	500	→	→	→	→	→	→	→	→	→	→					High	NC□□□□V	(—)
	Corrosion Resistant Ceramic Bearing	< 10000	1000	→														High	NCT□□□□	(FA)
	High Corrosion Resistance Ceramic Bearing	< 10000	1000	→														High	NCZ□□□□	(FA)
High temperature environment	PN Bearing	< 10000	1000	→	→	→	→	→	→	→	→	→	→					Low	SE□□□□ZZST	(PN)
	MG Bearing	< 10000	1000	→	→	→	→	→	→	→	→	→	→					Low	SE□□□□ZZSTMG3	(YS)
	MO Bearing	< 10000	1000	→	→	→	→	→	→	→	→	→	→					Low	SE□□□□ZZSTMSA7	(YS)
	High Temperature Clean Pro Bearing	< 10000	1000	→	→	→	→	→	→	→	→	→	→	•				Low	SE□□□□ZZSTPRB	(YS)
	WS Bearing	< 4000	500	→	→	→	→	→	→	→	→	→	→					Low	SE□□□□ZZST	(WS)
	High Temperature Hybrid Ceramic Bearing	< 4000	500	→	→	→	→	→	→	→	→	→	→					High	3NC□□□□HT4	(GF)
	Full Complement Ceramic Ball Bearing	< 4000	500	→	→	→	→	→	→	→	→	→	→					High	NC□□□□V	(—)
Magnetic field environment	Non-magnetic Hybrid Ceramic Bearing	< 10000	1000	→														Low	3NC□□□□YH4	(FA)
	Ceramic Bearing	< 10000	1000	→														Low	NC□□□□	(FA)
	Full Complement Ceramic Ball Bearing	< 4000	500	→	→	→	→	→	→	→	→	→	→					Low	NC□□□□V	(—)
	Corrosion Resistant Ceramic Bearing	< 10000	1000	→														High	NCT□□□□	(FA)
	High Corrosion Resistance Ceramic Bearing	< 10000	1000	→														High	NCZ□□□□	(FA)
Electric field environment	Hybrid Ceramic Bearing	No less than 1.2 times that of steel bearings		→														Low	3NC□□□□ZZ	(FG)
	Corrosion Resistant Hybrid Ceramic Bearing	< 10000	1000	→														Low	3NC□□□□ZZMD4	(FA)
	Non-magnetic Hybrid Ceramic Bearing	< 10000	1000	→														Low	3NC□□□□YH4	(FA)
	Ceramic Bearing	< 10000	1000	→														Low	NC□□□□	(FA)
	Full Complement Ceramic Ball Bearing	< 4000	500	→	→	→	→	→	→	→	→	→	→					Low	NC□□□□V	(—)
	Corrosion Resistant Ceramic Bearing	< 10000	1000	→														High	NCT□□□□	(FA)
	High Corrosion Resistance Ceramic Bearing	< 10000	1000	→														High	NCZ□□□□	(FA)
High speed application	Hybrid Ceramic Bearing	No less than 1.2 times that of steel bearings		→														Low	3NC□□□□ZZ	(FG)

(1) dn value: Bearing bore diameter (mm) × Rotational speed (min⁻¹)

(2) The cleanliness classes may vary depending on operating conditions.

(3) The four blank boxes represent the basic number of the bearing. A basic number consists of three or four alphanumeric characters. A bearing number may be used as a convenience in the case of any queries to JTEKT.

2 3 Radial Ball Bearings

3-1 Clean Pro Bearing

This bearing is lubricated with a fluoropolymer coating over the entire surface of all bearing components.

Applicable Environments

- Clean
- Vacuum
- High speed
- Corrosive
- Magnetic field
- Electric field
- High temperature

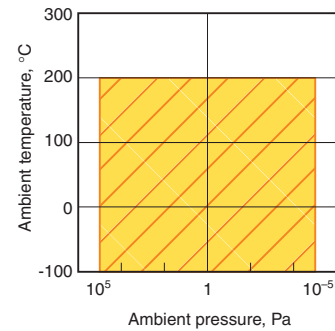
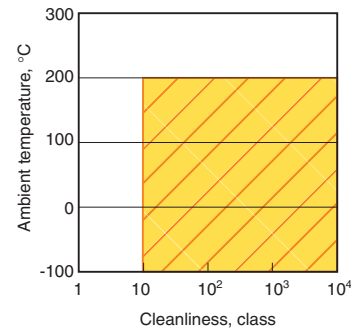

Product Specifications

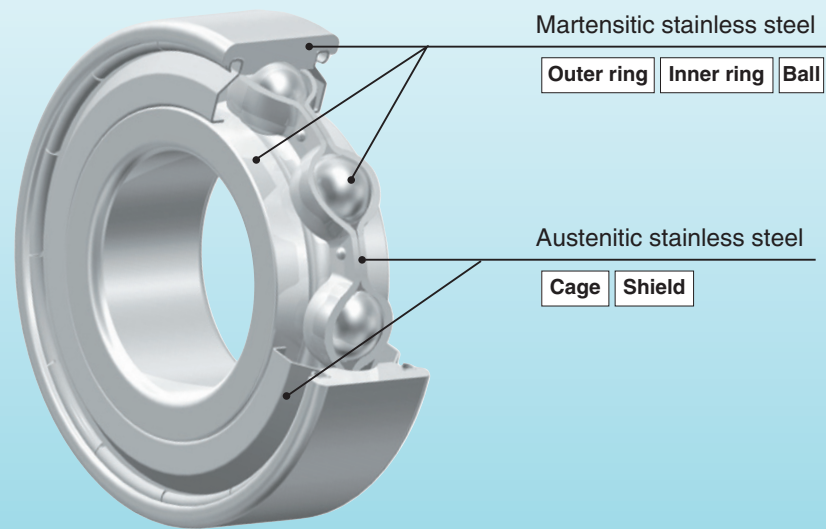

Bearing Numbering System

SE Basic bearing number **ZZSTPR** **YS**
 Solid lubricant Clean pro coating

Applications

- Semiconductor manufacturing equipment
- LCD manufacturing equipment
- Vacuum equipment
- Lithography equipment
- Sputtering equipment
- Vacuum motors

Performance

- Suitable for use in clean environments due to low particle emissions.
- Stable performance up to 200°C in a vacuum.

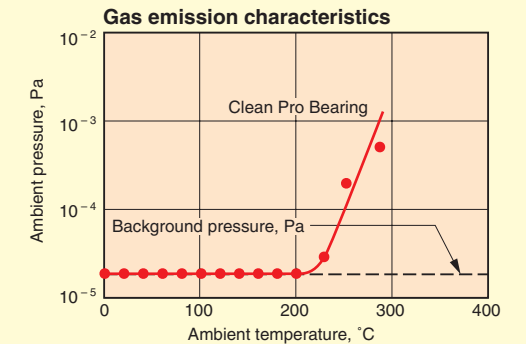
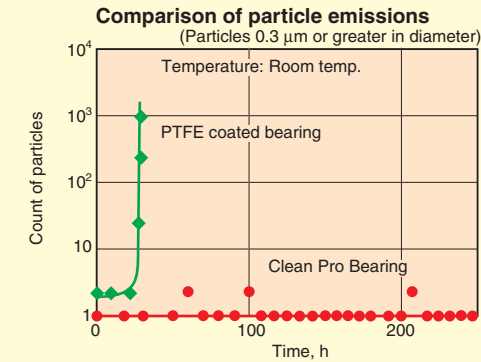

Dimensions Table

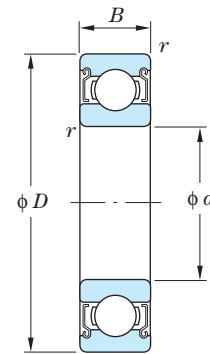

Dynamic equivalent load
 $P_r = XF_r + YF_a$
 (X and Y are as shown below.)
 Static equivalent load
 $P_{0r} = 0.6F_r + 0.5F_a$
 When P_{0r} is smaller than F_r ,
 $P_{0r} = F_r$

$\frac{f_0 F_a}{C_{0r}}$	e	$\frac{F_a}{F_r} \leq e$		$\frac{F_a}{F_r} > e$	
		X	Y	X	Y
0.172	0.19				2.30
0.345	0.22				1.99
0.689	0.26				1.71
1.03	0.28				1.55
1.38	0.30	1	0	0.56	1.45
2.07	0.34				1.31
3.45	0.38				1.15
5.17	0.42				1.04
6.89	0.44				1.00

* Colors in the "Bearing No." column indicate the classification of the periods for delivery as shown below.
 Available from stock
 30 days after receiving an order
 45 days after receiving an order
 Determined after consultation on each inquiry

Boundary dimensions mm				Bearing No.	Basic load ratings ¹⁾ kN		Factor f_0	Permissible radial load N	Limiting speed min ⁻¹
d	D	B	r (min.)		C_r	C_{0r}			
4	12	4	0.2	SE604ZZSTPRC3 YS	0.97	0.36	12.4	30	1 000
	13	5	0.2	SE624ZZSTPRC3 YS	1.30	0.49	12.3	40	1 000
5	14	5	0.2	SE605ZZSTPRC3 YS	1.30	0.49	12.3	40	1 000
	16	5	0.3	SE625-5ZZSTPRC3 YS	1.75	0.67	12.4	55	1 000
6	17	6	0.3	SE606ZZSTPRC3 YS	1.95	0.74	12.2	60	1 000
	19	6	0.3	SE626ZZSTPRC3 YS	2.60	1.05	12.3	80	1 000
7	19	6	0.3	SE607ZZSTPRC3 YS	2.60	1.05	12.3	80	1 000
	22	7	0.3	SE627ZZSTPRC3 YS	3.30	1.35	12.4	100	1 000
8	22	7	0.3	SE608ZZSTPRC3 YS	3.30	1.35	12.4	100	1 000
	24	8	0.3	SE628ZZSTPRC3 YS	3.35	1.40	12.8	100	1 000
9	24	7	0.3	SE609ZZSTPRC3 YS	3.35	1.40	12.8	100	1 000
	26	8	0.6	SE629ZZSTPRC3 YS	4.55	1.95	12.4	135	970
9.525	22.225	7.142	0.5	SEEE3SZSTPRC3 YS	3.35	1.40	12.8	100	1 000
10	26	8	0.3	SE6000ZZSTPRC3 YS	4.55	1.95	12.3	135	1 000
	30	9	0.6	SE6200ZZSTPRC3 YS	5.10	2.40	13.2	155	860
12	28	8	0.3	SE6001ZZSTPRC3 YS	5.10	2.40	13.2	155	830
	32	10	0.6	SE6201ZZSTPRC3 YS	6.80	3.05	12.3	205	770
15	32	9	0.3	SE6002ZZSTPRC3 YS	5.60	2.85	13.9	170	660
	35	11	0.6	SE6202ZZSTPRC3 YS	7.65	3.75	13.2	230	610
17	35	10	0.3	SE6003ZZSTPRC3 YS	6.00	3.25	14.4	180	580
	40	12	0.6	SE6203ZZSTPRC3 YS	9.55	4.80	13.2	285	530
20	42	12	0.6	SE6004ZZSTPRC3 YS	9.40	5.05	13.9	280	500
	47	14	1	SE6204ZZSTPRC3 YS	12.8	6.65	13.2	385	450
25	47	12	0.6	SE6005ZZSTPRC3 YS	10.1	5.85	14.5	305	400
	52	15	1	SE6205ZZSTPRC3 YS	14.0	7.85	13.9	420	360
30	55	13	1	SE6006ZZSTPRC3 YS	13.2	8.25	14.7	395	330
	62	16	1	SE6206ZZSTPRC3 YS	19.5	11.3	13.9	585	300
35	62	14	1	SE6007ZZSTPRC3 YS	15.9	10.3	14.9	475	280
	72	17	1.1	SE6207ZZSTPRC3 YS	25.7	15.4	13.9	770	250
40	68	15	1	SE6008ZZSTPRC3 YS	16.7	11.5	15.2	500	250
	80	18	1.1	SE6208ZZSTPRC3 YS	29.1	17.8	14.0	875	220

Note 1) The basic load ratings are those of normal bearing (used to calculate lubrication life).
 The permissible radial loads can be regarded as the maximum loads applicable to individual bearings.
 [Remark] When other sizes are used, consult with JTEKT.

3-2 High Temperature Clean Pro Bearing

This bearing has a fluoropolymer coating on its rolling surface as the lubricant.

Applicable Environments

- Clean
- Vacuum
- High speed
- Corrosive
- Magnetic field
- Electric field
- High temperature

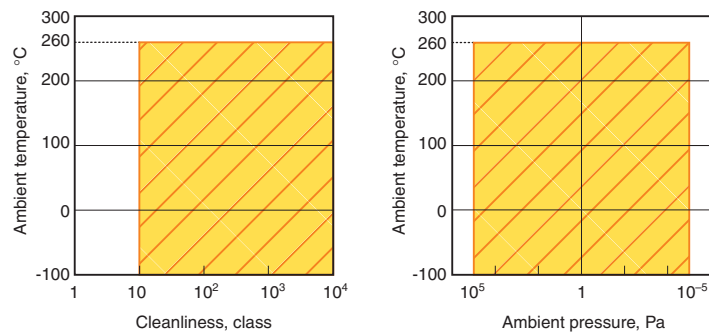

Product Specifications

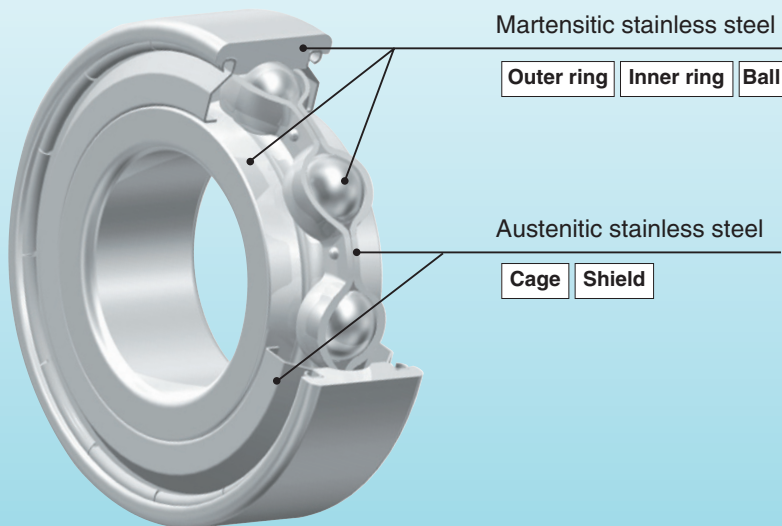

Bearing Numbering System

SE Basic bearing number **ZZSTPRBYS**
 Solid lubricant High temperature clean pro coating

Performance

● Comparable to the Clean Pro Bearing in low particle emissions.

● Compatible with temperatures of up to 260°C in a vacuum.

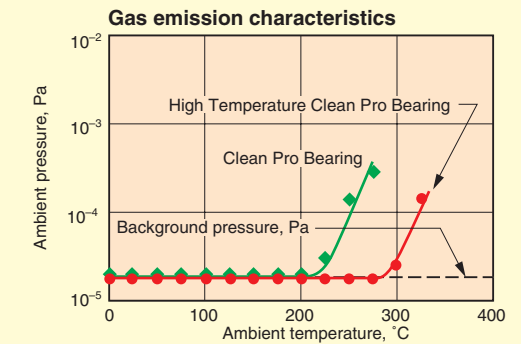
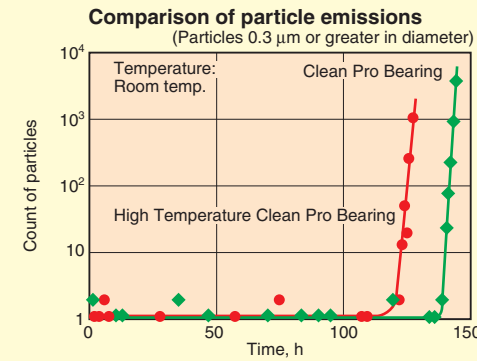

Dimensions Table

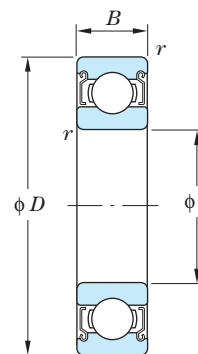

Dynamic equivalent load
 $P_r = XF_r + YF_a$
 (X and Y are as shown below.)
 Static equivalent load
 $P_{0r} = 0.6F_r + 0.5F_a$
 When P_{0r} is smaller than F_r ,
 $P_{0r} = F_r$

$\frac{f_0 F_a}{C_{0r}}$	e	$\frac{F_a}{F_r} \leq e$		$\frac{F_a}{F_r} > e$	
		X	Y	X	Y
0.172	0.19	1	0	0.56	2.30
0.345	0.22				1.99
0.689	0.26				1.71
1.03	0.28				1.55
1.38	0.30				1.45
2.07	0.34				1.31
3.45	0.38		1.15		
5.17	0.42		1.04		
6.89	0.44		1.00		

* Colors in the "Bearing No." column indicate the classification of the periods for delivery as shown below.
 Available from stock
 30 days after receiving an order
 45 days after receiving an order
 Determined after consultation on each inquiry

Boundary dimensions mm				Bearing No.	Factor f_0	Permissible radial load N	Limiting speed min ⁻¹
d	D	B	r (min.)				
4	12	4	0.2	SE604ZZSTPRBC3 YS	12.4	30	1 000
	13	5	0.2	SE624ZZSTPRBC3 YS	12.3	40	1 000
5	14	5	0.2	SE605ZZSTPRBC3 YS	12.3	40	1 000
	16	5	0.3	SE625-5ZZSTPRBC3 YS	12.4	55	1 000
6	17	6	0.3	SE606ZZSTPRBC3 YS	12.2	60	1 000
	19	6	0.3	SE626ZZSTPRBC3 YS	12.3	80	1 000
7	19	6	0.3	SE607ZZSTPRBC3 YS	12.3	80	1 000
	22	7	0.3	SE627ZZSTPRBC3 YS	12.4	100	1 000
8	22	7	0.3	SE608ZZSTPRBC3 YS	12.4	100	1 000
	24	8	0.3	SE628ZZSTPRBC3 YS	12.8	100	1 000
9	24	7	0.3	SE609ZZSTPRBC3 YS	12.8	100	1 000
	26	8	0.6	SE629ZZSTPRBC3 YS	12.4	135	970
9.525	22.225	7.142	0.5	SEEE3SZSTPRBC3 YS	12.8	100	1 000
10	26	8	0.3	SE600ZZSTPRBC3 YS	12.3	135	1 000
	30	9	0.6	SE6200ZZSTPRBC3 YS	13.2	155	860
12	28	8	0.3	SE6001ZZSTPRBC3 YS	13.2	155	830
	32	10	0.6	SE6201ZZSTPRBC3 YS	12.3	205	770
15	32	9	0.3	SE6002ZZSTPRBC3 YS	13.9	170	660
	35	11	0.6	SE6202ZZSTPRBC3 YS	13.2	230	610
17	35	10	0.3	SE6003ZZSTPRBC3 YS	14.4	180	580
	40	12	0.6	SE6203ZZSTPRBC3 YS	13.2	285	530
20	42	12	0.6	SE6004ZZSTPRBC3 YS	13.9	280	500
	47	14	1	SE6204ZZSTPRBC3 YS	13.2	385	450
25	47	12	0.6	SE6005ZZSTPRBC3 YS	14.5	305	400
	52	15	1	SE6205ZZSTPRBC3 YS	13.9	420	360
30	55	13	1	SE6006ZZSTPRBC3 YS	14.7	395	330
	62	16	1	SE6206ZZSTPRBC3 YS	13.9	585	300
35	62	14	1	SE6007ZZSTPRBC3 YS	14.9	475	280
	72	17	1.1	SE6207ZZSTPRBC3 YS	13.9	770	250
40	68	15	1	SE6008ZZSTPRBC3 YS	15.2	500	250
	80	18	1.1	SE6208ZZSTPRBC3 YS	14.0	875	220

[Remark] 1) Bearings with a radial internal clearance of C4 are also available.
 2) When other sizes are used, consult with JTEKT.

Applications

- Semiconductor manufacturing equipment
- LCD manufacturing equipment
- Transfer systems
- Vacuum equipment
- Sputtering equipment

3-3 Clean Pro PRZ Bearing

This bearing has a fluoropolymer gel coating on its rolling surfaces as the lubricant.

Applicable Environments

- Clean
- Vacuum
- High speed
- Corrosive
- Magnetic field
- Electric field
- High temperature

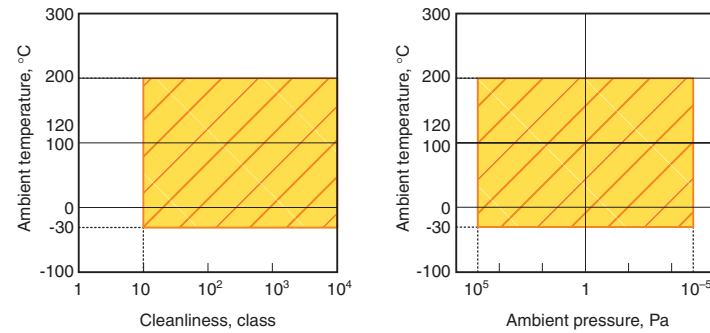

Product Specifications

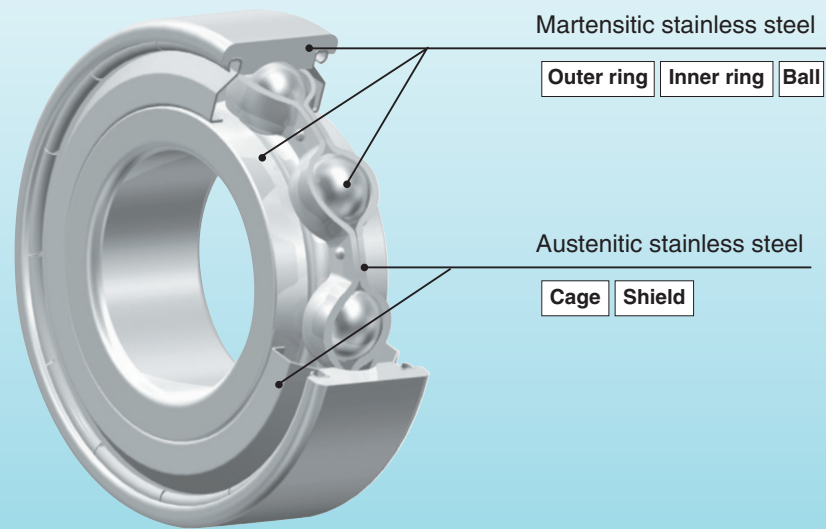

Bearing Numbering System

SE Basic bearing number ZZSTPRZYS
 Solid lubricant Clean pro PRZ coating

Performance

- Clean Pro PRZ has better characteristics in low particle emissions than Clean Pro Bearings.
- Clean Pro PRZ has longer service life than Clean Pro Bearings.
- Clean Pro PRZ has better characteristics in low gas emission than Clean Pro Bearings.

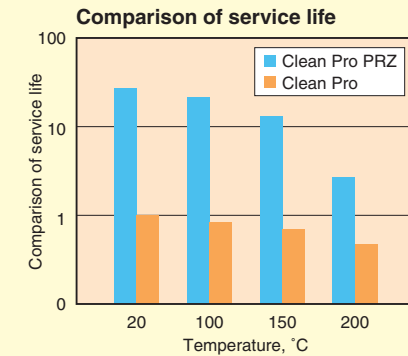
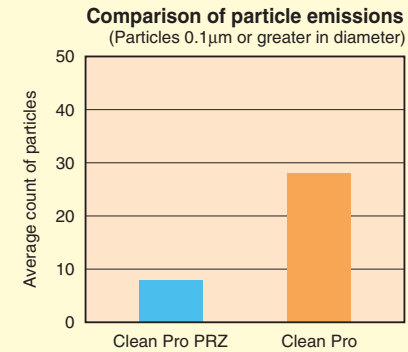

Dimensions Table

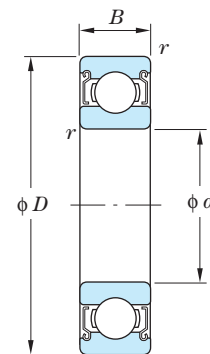

Dynamic equivalent load
 $P_r = XF_r + YF_a$
 (X and Y are as shown below.)
 Static equivalent load
 $P_{0r} = 0.6F_r + 0.5F_a$
 When P_{0r} is smaller than F_r ,
 $P_{0r} = F_r$

$\frac{f_0 F_a}{C_{0r}}$	e	$\frac{F_a}{F_r} \leq e$		$\frac{F_a}{F_r} > e$	
		X	Y	X	Y
0.172	0.19				2.30
0.345	0.22				1.99
0.689	0.26				1.71
1.03	0.28				1.55
1.38	0.30	1	0	0.56	1.45
2.07	0.34				1.31
3.45	0.38				1.15
5.17	0.42				1.04
6.89	0.44				1.00

* Colors in the "Bearing No." column indicate the classification of the periods for delivery as shown below.
 Available from stock
 30 days after receiving an order
 45 days after receiving an order
 Determined after consultation on each inquiry

Boundary dimensions mm	mm			Bearing No.	Factor f_0	Permissible radial load N	Limiting speed min^{-1}
	d	D	r (min.)				
5	14	5	0.2	SE605ZZSTPRZC3 YS	12.3	40	1 000
	16	5	0.3	SE625-5ZZSTPRZC3 YS	12.4	55	1 000
6	17	6	0.3	SE606ZZSTPRZC3 YS	12.2	60	1 000
	19	6	0.3	SE626ZZSTPRZC3 YS	12.3	80	1 000
7	19	6	0.3	SE607ZZSTPRZC3 YS	12.3	80	1 000
	22	7	0.3	SE627ZZSTPRZC3 YS	12.4	100	1 000
8	22	7	0.3	SE608ZZSTPRZC3 YS	12.4	100	1 000
	24	8	0.3	SE628ZZSTPRZC3 YS	12.8	100	1 000
9	24	7	0.3	SE609ZZSTPRZC3 YS	12.8	100	1 000
	26	8	0.6	SE629ZZSTPRZC3 YS	12.4	135	970
9.525	22.225	7.142	0.5	SEEE3SZZSTPRZC3 YS	12.8	100	1 000
10	26	8	0.3	SE600ZZSTPRZC3 YS	12.3	135	1 000
	30	9	0.6	SE6200ZZSTPRZC3 YS	13.2	155	860
12	28	8	0.3	SE6001ZZSTPRZC3 YS	13.2	155	830
	32	10	0.6	SE6201ZZSTPRZC3 YS	12.3	205	770
15	32	9	0.3	SE6002ZZSTPRZC3 YS	13.9	170	660
	35	11	0.6	SE6202ZZSTPRZC3 YS	13.2	230	610
17	35	10	0.3	SE6003ZZSTPRZC3 YS	14.4	180	580
	40	12	0.6	SE6203ZZSTPRZC3 YS	13.2	285	530
20	42	12	0.6	SE6004ZZSTPRZC3 YS	13.9	280	500
	47	14	1	SE6204ZZSTPRZC3 YS	13.2	385	450
25	47	12	0.6	SE6005ZZSTPRZC3 YS	14.5	305	400
	52	15	1	SE6205ZZSTPRZC3 YS	13.9	420	360
30	55	13	1	SE6006ZZSTPRZC3 YS	14.7	395	330
	62	16	1	SE6206ZZSTPRZC3 YS	13.9	585	300
35	62	14	1	SE6007ZZSTPRZC3 YS	14.9	475	280
	72	17	1.1	SE6207ZZSTPRZC3 YS	13.9	770	250
40	68	15	1	SE6008ZZSTPRZC3 YS	15.2	500	250
	80	18	1.1	SE6208ZZSTPRZC3 YS	14.0	875	220

[Remark] When other sizes are used, consult with JTEKT.

Applications

- Semiconductor manufacturing equipment
- Vacuum motors
- Transfer systems
- Vacuum equipment
- Lithography equipment

3 - 4 DL Bearing

This bearing is lubricated with the packed fluorinated KDL grease, which is suitable for use in clean environments and vacuum environments.

Applicable Environments

- Clean
- Vacuum
- High speed
- Corrosive
- Magnetic field
- Electric field
- High temperature

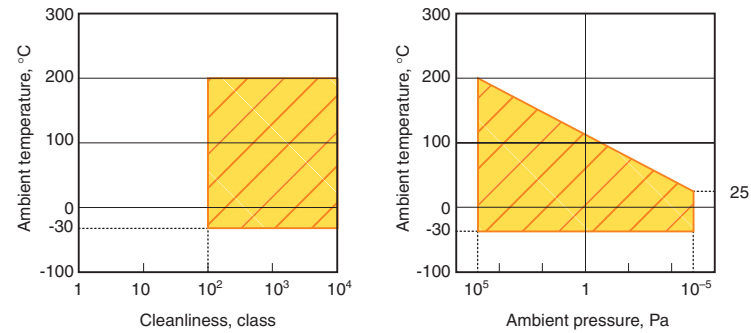

Product Specifications

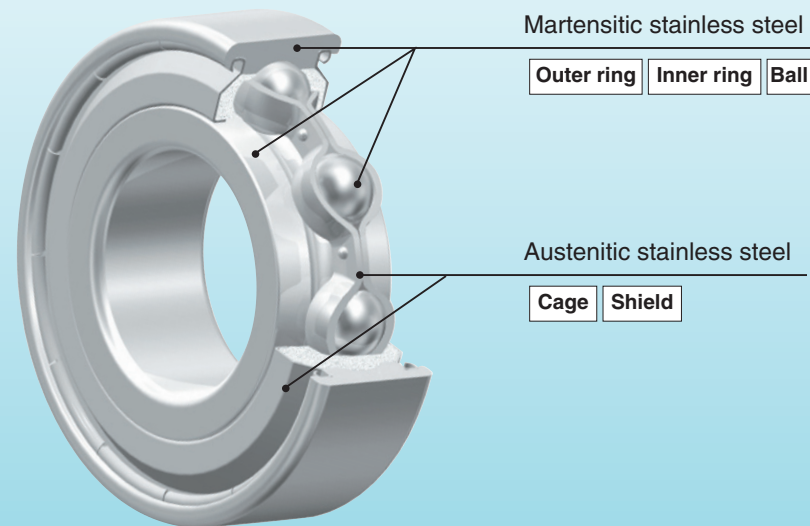

Bearing Numbering System

SV Basic bearing number ZZST YS
Grease packed

Performance

Suitable for clean and vacuum applications thanks to low particle emissions.

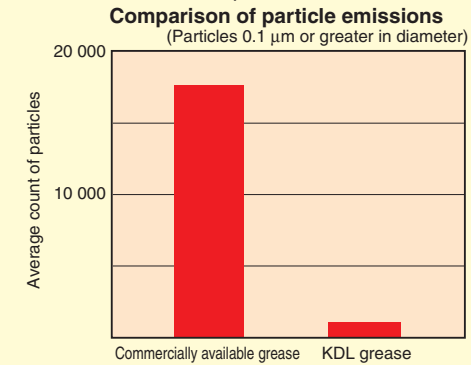

Grease properties

		KDL grease
Thickener		PTFE
Base oil		PFPE
Dropping point		None
Evaporation (200°C×22h)		0.1wt%max.
Oil separation (100°C×24h)		2wt%max.
Operating temperature range	In atmospheric air	-30 to 200°C
	In vacuum	-30 to 100°C

Dimensions Table

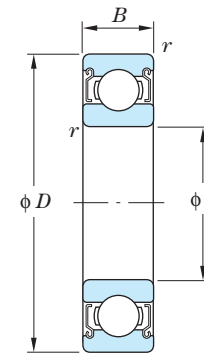

Dynamic equivalent load
 $P_r = XF_r + YF_a$
 (X and Y are as shown below.)
 Static equivalent load
 $P_{0r} = 0.6F_r + 0.5F_a$
 When P_{0r} is smaller than F_r ,
 $P_{0r} = F_r$

$\frac{f_0 F_a}{C_{0r}}$	e	$\frac{F_a}{F_r} \leq e$		$\frac{F_a}{F_r} > e$	
		X	Y	X	Y
0.172	0.19				2.30
0.345	0.22				1.99
0.689	0.26				1.71
1.03	0.28				1.55
1.38	0.30	1	0	0.56	1.45
2.07	0.34				1.31
3.45	0.38				1.15
5.17	0.42				1.04
6.89	0.44				1.00

* Colors in the "Bearing No." column indicate the classification of the periods for delivery as shown below.
 Available from stock
 30 days after receiving an order
 45 days after receiving an order
 Determined after consultation on each inquiry

Boundary dimensions mm	Bearing No.	Basic load ratings ¹⁾ kN		Factor	Limiting ²⁾ speed min ⁻¹
		C_r	C_{0r}		
4	SV604ZZSTC3 YS	0.80	0.30	12.4	10 000
	SV624ZZSTC3 YS	1.10	0.40	12.3	9 000
5	SV605ZZSTC3 YS	1.10	0.40	12.3	8 000
	SV625-5ZZSTC3 YS	1.45	0.55	12.4	6 700
6	SV606ZZSTC3 YS	1.65	0.60	12.2	6 600
	SV626ZZSTC3 YS	2.20	0.85	12.3	5 900
7	SV607ZZSTC3 YS	2.20	0.85	12.3	5 700
	SV627ZZSTC3 YS	2.80	1.10	12.4	4 900
8	SV608ZZSTC3 YS	2.80	1.10	12.4	5 000
	SV628ZZSTC3 YS	2.85	1.10	12.8	4 700
9	SV609ZZSTC3 YS	2.85	1.10	12.8	4 400
	SV629ZZSTC3 YS	3.90	1.55	12.4	3 900
9.525	SV609ZZSTC3 YS	2.85	1.10	12.8	5 600
10	SV6000ZZSTC3 YS	3.85	1.55	12.3	4 000
	SV6200ZZSTC3 YS	4.35	1.90	13.2	3 400
12	SV6001ZZSTC3 YS	4.35	1.90	13.2	3 300
	SV6201ZZSTC3 YS	5.75	2.45	12.3	3 100
15	SV6002ZZSTC3 YS	4.75	2.25	13.9	2 600
	SV6202ZZSTC3 YS	6.50	3.00	13.2	2 400
17	SV6003ZZSTC3 YS	5.10	2.60	14.4	2 300
	SV6203ZZSTC3 YS	8.15	3.85	13.2	2 100
20	SV6004ZZSTC3 YS	8.00	4.05	13.9	2 000
	SV6204ZZSTC3 YS	10.9	5.35	13.2	1 800
25	SV6005ZZSTC3 YS	8.55	4.65	14.5	1 600
	SV6205ZZSTC3 YS	11.9	6.30	13.9	1 400
30	SV6006ZZSTC3 YS	11.2	6.60	14.7	1 300
	SV6206ZZSTC3 YS	16.5	9.05	13.9	1 200
35	SV6007ZZSTC3 YS	13.5	8.25	14.9	1 100
	SV6207ZZSTC3 YS	21.8	12.3	13.9	1 000
40	SV6008ZZSTC3 YS	14.2	9.20	15.2	1 000
	SV6208ZZSTC3 YS	24.8	14.3	14.0	900

Note 1) The basic load ratings are those of bearing made from SUS440C.
 To calculate dynamic equivalent radial loads, multiply the C_{0r} value in this table by 1.25.
 2) The limiting speed is that determined based on the condition that the cleanliness requirement is class 100.
 [Remark] When other sizes are used, consult with JTEKT.

Applications

- Semiconductor manufacturing equipment
- Vacuum pumps
- LCD manufacturing equipment
- Transfer robots

3 - 5 PN Bearing

This bearing has a highly heat resistant solid lubricant, such as molybdenum disulfide included in the cage material.

Applicable Environments

- Clean
- Magnetic field
- Vacuum
- Electric field
- High speed
- High temperature
- Corrosive

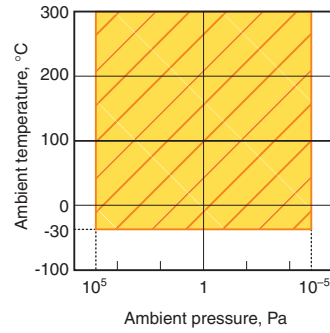

Product Specifications

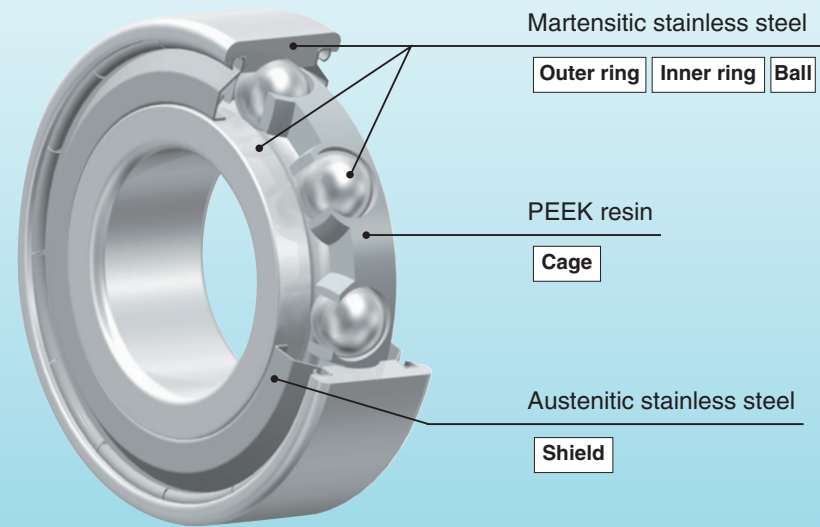

Bearing Numbering System

SE Basic bearing number **ZZSTPN**
 Solid lubricant Molded PEEK resin cage

Applications

- Carton manufacturing equipment
- LCD cleaning equipment

Performance

- Useful up to 300°C in a vacuum.
- Excellent in lubricant service life in temperatures from room temp. to 300°C.

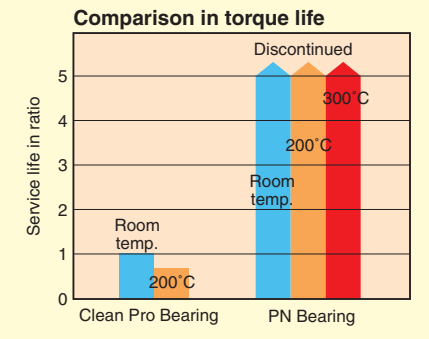
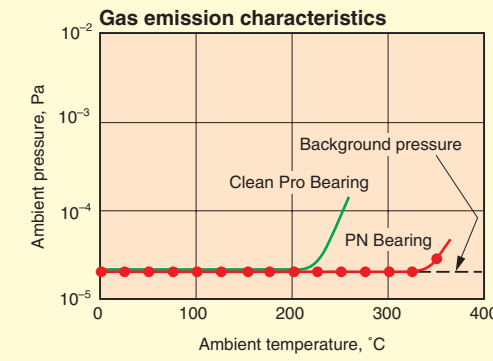

Dimensions Table

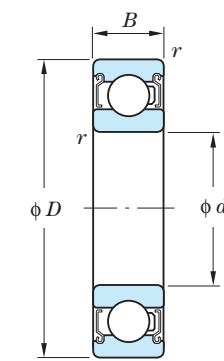

Dynamic equivalent load
 $P_r = XF_r + YF_a$
 (X and Y are as shown below.)

Static equivalent load
 $P_{0r} = 0.6F_r + 0.5F_a$
 When P_{0r} is smaller than F_r ,
 $P_{0r} = F_r$

$\frac{f_0 F_a}{C_{0r}}$	e	$\frac{F_a}{F_r} \leq e$		$\frac{F_a}{F_r} > e$	
		X	Y	X	Y
0.172	0.19	1	0	0.56	2.30
0.345	0.22				1.99
0.689	0.26				1.71
1.03	0.28				1.55
1.38	0.30				1.45
2.07	0.34				1.31
3.45	0.38				1.15
5.17	0.42				1.04
6.89	0.44	1.00	1.00		

* Colors in the "Bearing No." column indicate the classification of the periods for delivery as shown below.

- Available from stock
- 30 days after receiving an order
- 45 days after receiving an order
- Determined after consultation on each inquiry

Boundary dimensions mm				Bearing No.	Factor f_0	Permissible radial load N	Limiting speed min^{-1}
d	D	B	r (min.)				
4	12	4	0.2	SE604ZZSTC3 PN	12.4	30	1 000
	13	5	0.2	SE624ZZSTC3 PN	12.3	40	1 000
5	14	5	0.2	SE605ZZSTC3 PN	12.3	40	1 000
	16	5	0.3	SE625-5ZZSTC3 PN	12.4	55	1 000
6	17	6	0.3	SE606ZZSTC3 PN	12.2	60	1 000
	19	6	0.3	SE626ZZSTC3 PN	12.3	80	1 000
7	19	6	0.3	SE607ZZSTC3 PN	12.3	80	1 000
	22	7	0.3	SE627ZZSTC3 PN	12.4	100	1 000
8	22	7	0.3	SE608ZZSTC3 PN	12.4	100	1 000
	24	8	0.3	SE628ZZSTC3 PN	12.8	100	1 000
9	24	7	0.3	SE609ZZSTC3 PN	12.8	100	1 000
	26	8	0.6	SE629ZZSTC3 PN	12.4	135	970
9.525	22.225	7.142	0.5	SEEE3SZSTC3 PN	12.8	100	1 000
10	26	8	0.3	SE6000ZZSTC3 PN	12.3	135	1 000
	30	9	0.6	SE6200ZZSTC3 PN	13.2	155	860
12	28	8	0.3	SE6001ZZSTC3 PN	13.2	155	830
	32	10	0.6	SE6201ZZSTC3 PN	12.3	205	770
15	32	9	0.3	SE6002ZZSTC3 PN	13.9	170	660
	35	11	0.6	SE6202ZZSTC3 PN	13.2	230	610
17	35	10	0.3	SE6003ZZSTC3 PN	14.4	180	580
	40	12	0.6	SE6203ZZSTC3 PN	13.2	285	530
20	42	12	0.6	SE6004ZZSTC3 PN	13.9	280	500
	47	14	1	SE6204ZZSTC3 PN	13.2	385	450
25	47	12	0.6	SE6005ZZSTC3 PN	14.5	305	400
	52	15	1	SE6205ZZSTC3 PN	13.9	420	360
30	55	13	1	SE6006ZZSTC3 PN	14.7	395	330
	62	16	1	SE6206ZZSTC3 PN	13.9	585	300
35	62	14	1	SE6007ZZSTC3 PN	14.9	475	280
	72	17	1.1	SE6207ZZSTC3 PN	13.9	770	250
40	68	15	1	SE6008ZZSTC3 PN	15.2	500	250
	80	18	1.1	SE6208ZZSTC3 PN	14.0	875	220

[Remark] When other sizes are used, consult with JTEKT.

3 - 6 WS Bearing

This bearing has extremely heat resistant tungsten disulfide included in the separator material as the lubricant.

Applicable Environments

- Clean
- Magnetic field
- Vacuum**
- Electric field
- High speed
- High temperature**
- Corrosive

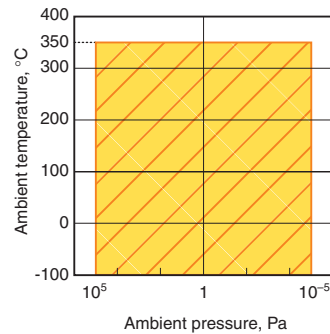

Product Specifications

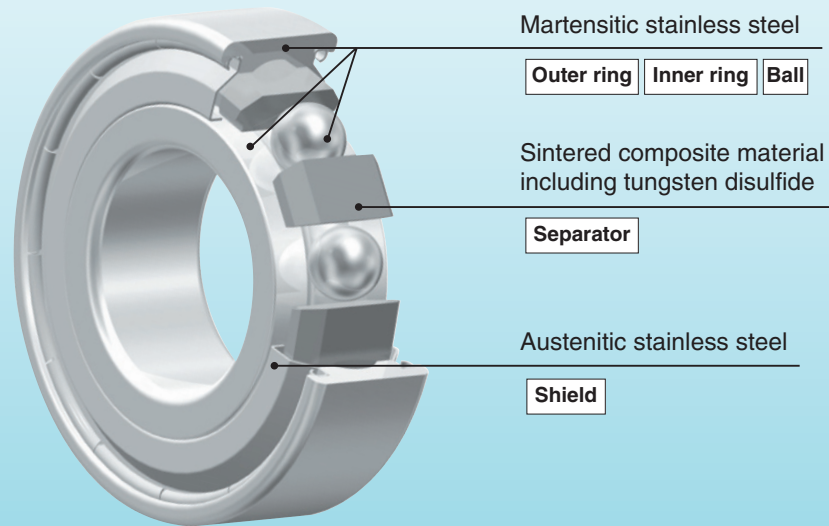

Bearing Numbering System

SE Basic bearing number **ZZST WS**
 Solid lubricant Separators including tungsten disulfide

Applications

- Semiconductor manufacturing equipment
- LCD manufacturing equipment
- Vacuum evaporator
- Plasma display panel manufacturing equipment

Performance

- Free from problematic gas emissions under the conditions of up to 10^{-5} Pa and up to 350°C .
- Highly heat resistant and superior to the Clean Pro Bearing in lubrication life.

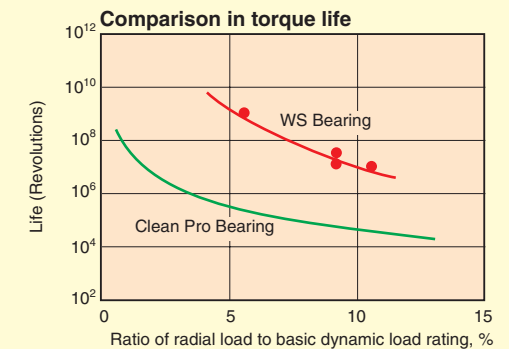
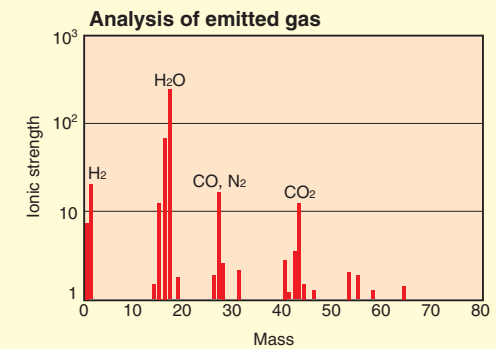

Dimensions Table

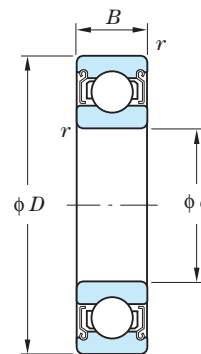

Dynamic equivalent load
 $P_r = XF_r + YF_a$
 (X and Y are as shown below.)
 Static equivalent load
 $P_{0r} = 0.6F_r + 0.5F_a$
 When P_{0r} is smaller than F_r ,
 $P_{0r} = F_r$

$\frac{f_0 F_a}{C_{0r}}$	e	$\frac{F_a}{F_r} \leq e$		$\frac{F_a}{F_r} > e$	
		X	Y	X	Y
0.172	0.19				2.30
0.345	0.22				1.99
0.689	0.26				1.71
1.03	0.28				1.55
1.38	0.30	1	0	0.56	1.45
2.07	0.34				1.31
3.45	0.38				1.15
5.17	0.42				1.04
6.89	0.44				1.00

* Colors in the "Bearing No." column indicate the classification of the periods for delivery as shown below.

- Available from stock
- 30 days after receiving an order
- 45 days after receiving an order
- Determined after consultation on each inquiry

Boundary dimensions mm				Bearing No.	Factor f_0	Permissible radial load N	Limiting speed min^{-1}
d	D	B	r (min.)				
6	17	6	0.3	SE606ZZSTC4 WS	12.2	100	500
	19	6	0.3	SE626ZZSTC4 WS	12.3	130	500
7	19	6	0.3	SE607ZZSTC4 WS	12.3	130	500
	22	7	0.3	SE627ZZSTC4 WS	12.4	165	490
8	22	7	0.3	SE608ZZSTC4 WS	12.4	165	500
	24	8	0.3	SE628ZZSTC4 WS	12.8	170	470
9	24	7	0.3	SE609ZZSTC4 WS	12.8	170	440
	26	8	0.6	SE629ZZSTC4 WS	12.4	230	390
9.525	22.225	7.142	0.5	SEEE3SZZSTC4 WS	12.8	165	410
10	26	8	0.3	SE600ZZSTC4 WS	12.3	230	400
	30	9	0.6	SE620ZZSTC4 WS	13.2	255	340
12	28	8	0.3	SE6001ZZSTC4 WS	13.2	255	330
	32	10	0.6	SE6201ZZSTC4 WS	12.3	340	310
15	32	9	0.3	SE6002ZZSTC4 WS	13.9	280	260
	35	11	0.6	SE6202ZZSTC4 WS	13.2	385	240
17	35	10	0.3	SE6003ZZSTC4 WS	14.4	300	230
	40	12	0.6	SE6203ZZSTC4 WS	13.2	480	210
20	42	12	0.6	SE6004ZZSTC4 WS	13.9	470	200
	47	14	1	SE6204ZZSTC4 WS	13.2	640	180
25	47	12	0.6	SE6005ZZSTC4 WS	14.5	505	160
	52	15	1	SE6205ZZSTC4 WS	13.9	700	140
30	55	13	1	SE6006ZZSTC4 WS	14.7	660	130
	62	16	1	SE6206ZZSTC4 WS	13.9	975	120
35	62	14	1	SE6007ZZSTC4 WS	14.9	795	110
	72	17	1.1	SE6207ZZSTC4 WS	13.9	1 285	100
40	68	15	1	SE6008ZZSTC4 WS	15.2	835	100
	80	18	1.1	SE6208ZZSTC4 WS	14.0	1 455	90

3-7 MO Bearing

This bearing has molybdenum disulfide baked on the surface of the stainless steel cage, as the lubricant.

Applicable Environments

- Clean
- Magnetic field
- Vacuum
- Electric field
- High speed
- High temperature
- Corrosive

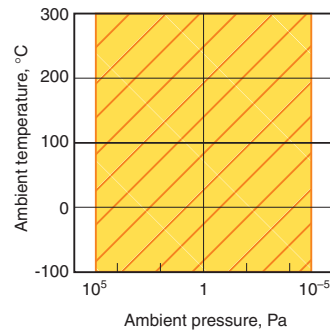

Product Specifications

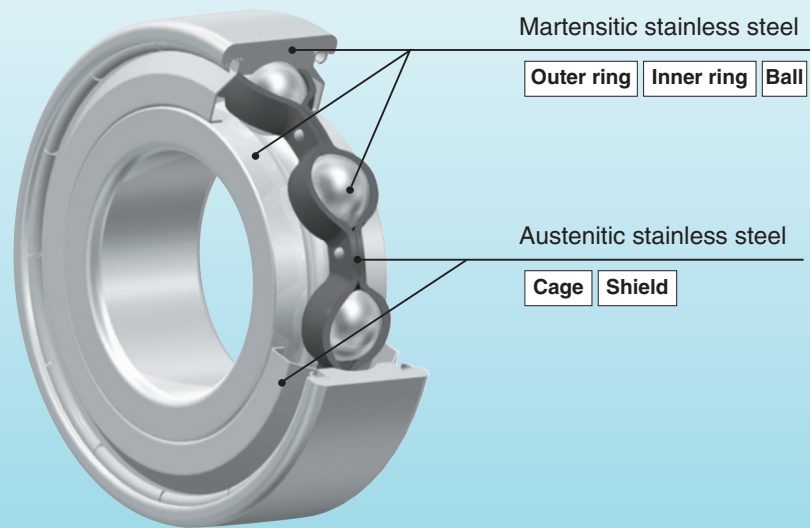

Bearing Numbering System

SE Basic bearing number **ZZSTMSA7YS**
 Solid lubricant Molybdenum disulfide baked stainless steel cage

Applications

- Semiconductor manufacturing equipment
- LCD manufacturing equipment
- Vacuum evaporator
- Turbo molecular pump
- Rotary furnaces

Performance

- Molybdenum disulfide compares to the common PTFE coating in lubrication life but is superior in heat resistance.

Comparison in lubrication life

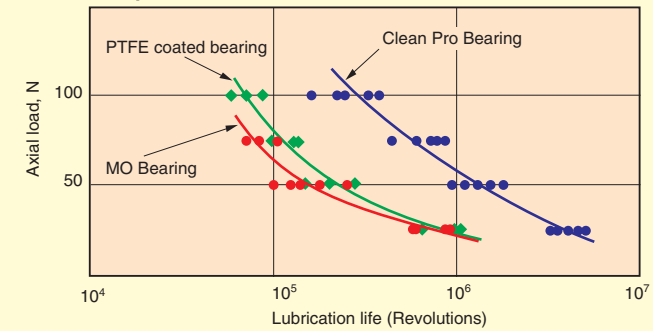

Dimensions Table

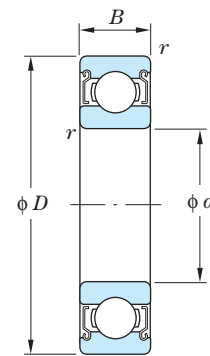

Dynamic equivalent load
 $P_r = XF_r + YF_a$
 (X and Y are as shown below.)
 Static equivalent load
 $P_{0r} = 0.6F_r + 0.5F_a$
 When P_{0r} is smaller than F_r .
 $P_{0r} = F_r$

$\frac{f_0 F_a}{C_{0r}}$	e	$\frac{F_a}{F_r} \leq e$		$\frac{F_a}{F_r} > e$	
		X	Y	X	Y
0.172	0.19				2.30
0.345	0.22				1.99
0.689	0.26				1.71
1.03	0.28	1	0	0.56	1.55
1.38	0.30				1.45
2.07	0.34				1.31
3.45	0.38				1.15
5.17	0.42				1.04
6.89	0.44				1.00

* Colors in the "Bearing No." column indicate the classification of the periods for delivery as shown below.
 Available from stock
 30 days after receiving an order
 45 days after receiving an order
 Determined after consultation on each inquiry

Boundary dimensions mm	Bearing No.	Basic load ratings ¹⁾ kN		Factor f_0	Permissible radial load N	Limiting speed min ⁻¹
		C_r	C_{0r}			
4	SE604ZZSTMSA7C3 YS	0.97	0.36	12.4	30	1 000
	SE624ZZSTMSA7C3 YS	1.30	0.49	12.3	40	1 000
5	SE605ZZSTMSA7C3 YS	1.30	0.49	12.3	40	1 000
	SE625-5ZZSTMSA7C3 YS	1.75	0.67	12.4	55	1 000
6	SE606ZZSTMSA7C3 YS	1.95	0.74	12.2	60	1 000
	SE626ZZSTMSA7C3 YS	2.60	1.05	12.3	80	1 000
7	SE607ZZSTMSA7C3 YS	2.60	1.05	12.3	80	1 000
	SE627ZZSTMSA7C3 YS	3.30	1.35	12.4	100	1 000
8	SE608ZZSTMSA7C3 YS	3.30	1.35	12.4	100	1 000
	SE628ZZSTMSA7C3 YS	3.35	1.40	12.8	100	1 000
9	SE609ZZSTMSA7C3 YS	3.35	1.40	12.8	100	1 000
	SE629ZZSTMSA7C3 YS	4.55	1.95	12.4	135	970
9.525	SEEE3SZSTMSA7C3 YS	3.35	1.40	12.8	100	1 000
10	SE6000ZZSTMSA7C3 YS	4.55	1.95	12.3	135	1 000
	SE6200ZZSTMSA7C3 YS	5.10	2.40	13.2	155	860
12	SE6001ZZSTMSA7C3 YS	5.10	2.40	13.2	155	830
	SE6201ZZSTMSA7C3 YS	6.80	3.05	12.3	205	770
15	SE6002ZZSTMSA7C3 YS	5.60	2.85	13.9	170	660
	SE6202ZZSTMSA7C3 YS	7.65	3.75	13.2	230	610
17	SE6003ZZSTMSA7C3 YS	6.00	3.25	14.4	180	580
	SE6203ZZSTMSA7C3 YS	9.55	4.80	13.2	285	530
20	SE6004ZZSTMSA7C3 YS	9.40	5.05	13.9	280	500
	SE6204ZZSTMSA7C3 YS	12.8	6.65	13.2	385	450
25	SE6005ZZSTMSA7C3 YS	10.1	5.85	14.5	305	400
	SE6205ZZSTMSA7C3 YS	14.0	7.85	13.9	420	360
30	SE6006ZZSTMSA7C3 YS	13.2	8.25	14.7	395	330
	SE6206ZZSTMSA7C3 YS	19.5	11.3	13.9	585	300
35	SE6007ZZSTMSA7C3 YS	15.9	10.3	14.9	475	280
	SE6207ZZSTMSA7C3 YS	25.7	15.4	13.9	770	250
40	SE6008ZZSTMSA7C3 YS	16.7	11.5	15.2	500	250
	SE6208ZZSTMSA7C3 YS	29.1	17.8	14.0	875	220

Note 1) The basic load ratings are those of normal bearing (used to calculate lubrication life). The permissible radial loads can be regarded as the maximum loads applicable to individual bearings. [Remark] When other sizes are used, consult with JTEKT.

3 - 8 MG Bearing

This bearing has silver ion plated on the stainless steel balls, as the lubricant.

Applicable Environments

- Clean
- Magnetic field
- Vacuum
- Electric field
- High speed
- High temperature
- Corrosive

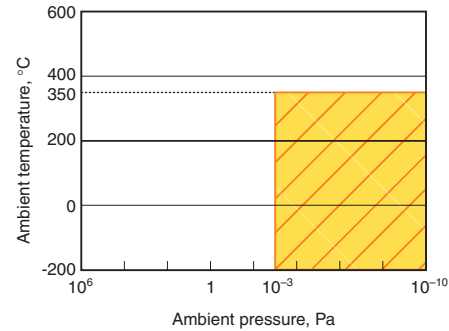

Product Specifications

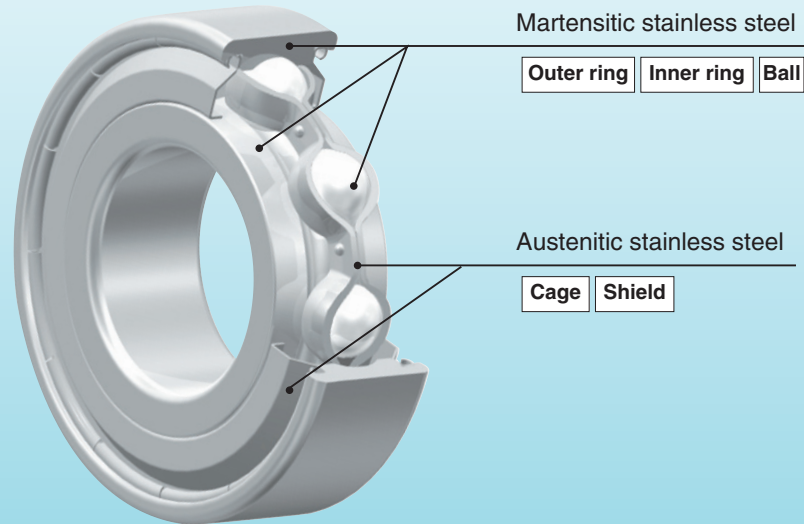

Bearing Numbering System

SE Basic bearing number **ZZSTMG3YS**
 Solid lubricant Silver ion plated balls

Performance

- Useful in an ultrahigh vacuum environment of 10^{-10} Pa thanks to low gas emissions in an ultrahigh vacuum.

Analysis of emitted gas

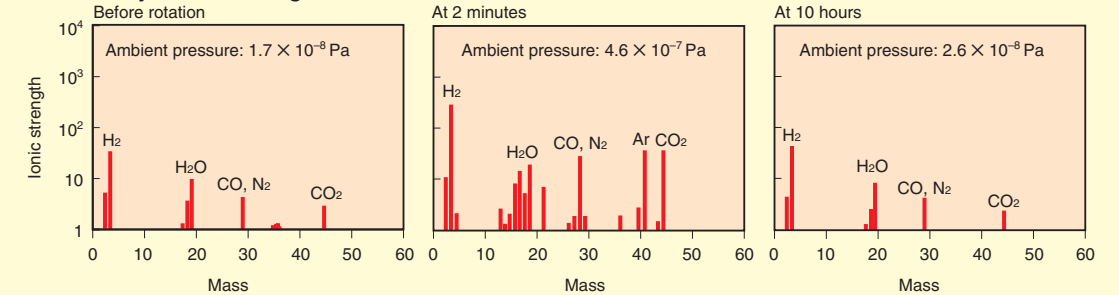

Dimensions Table

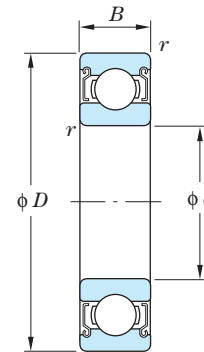

Dynamic equivalent load
 $P_r = XF_r + YF_a$
 (X and Y are as shown below.)

Static equivalent load
 $P_{0r} = 0.6F_r + 0.5F_a$
 When P_{0r} is smaller than F_r ,
 $P_{0r} = F_r$

$\frac{f_0 F_a}{C_{0r}}$	e	$\frac{F_a}{F_r} \leq e$		$\frac{F_a}{F_r} > e$	
		X	Y	X	Y
0.172	0.19				2.30
0.345	0.22				1.99
0.689	0.26				1.71
1.03	0.28				1.55
1.38	0.30				1.45
2.07	0.34				1.31
3.45	0.38				1.15
5.17	0.42				1.04
6.89	0.44				1.00
		1	0	0.56	

* Colors in the "Bearing No." column indicate the classification of the periods for delivery as shown below.

- Available from stock
- 30 days after receiving an order
- 45 days after receiving an order
- Determined after consultation on each inquiry

Boundary dimensions mm				Bearing No.	Basic load ratings ¹⁾ kN		Factor f_0	Permissible radial load N	Limiting speed min ⁻¹
d	D	B	r (min.)		C_r	C_{0r}			
4	12	4	0.2	SE604ZZSTMG3C4 YS	0.97	0.36	12.4	30	1 000
	13	5	0.2	SE624ZZSTMG3C4 YS	1.30	0.49	12.3	40	1 000
5	14	5	0.2	SE605ZZSTMG3C4 YS	1.30	0.49	12.3	40	1 000
	16	5	0.3	SE625-5ZZSTMG3C4 YS	1.75	0.67	12.4	55	1 000
6	17	6	0.3	SE606ZZSTMG3C4 YS	1.95	0.74	12.2	60	1 000
	19	6	0.3	SE626ZZSTMG3C4 YS	2.60	1.05	12.3	80	1 000
7	19	6	0.3	SE607ZZSTMG3C4 YS	2.60	1.05	12.3	80	1 000
	22	7	0.3	SE627ZZSTMG3C4 YS	3.30	1.35	12.4	100	1 000
8	22	7	0.3	SE608ZZSTMG3C4 YS	3.30	1.35	12.4	100	1 000
	24	8	0.3	SE628ZZSTMG3C4 YS	3.35	1.40	12.8	100	1 000
9	24	7	0.3	SE609ZZSTMG3C4 YS	3.35	1.40	12.8	100	1 000
	26	8	0.6	SE629ZZSTMG3C4 YS	4.55	1.95	12.4	135	970
9.525	22.225	7.142	0.5	SEEE3SZZSTMG3C4 YS	3.35	1.40	12.8	100	1 000
10	26	8	0.3	SE600ZZSTMG3C4 YS	4.55	1.95	12.3	135	1 000
	30	9	0.6	SE620ZZSTMG3C4 YS	5.10	2.40	13.2	155	860
12	28	8	0.3	SE6001ZZSTMG3C4 YS	5.10	2.40	13.2	155	830
	32	10	0.6	SE6201ZZSTMG3C4 YS	6.80	3.05	12.3	205	770
15	32	9	0.3	SE6002ZZSTMG3C4 YS	5.60	2.85	13.9	170	660
	35	11	0.6	SE6202ZZSTMG3C4 YS	7.65	3.75	13.2	230	610
17	35	10	0.3	SE6003ZZSTMG3C4 YS	6.00	3.25	14.4	180	580
	40	12	0.6	SE6203ZZSTMG3C4 YS	9.55	4.80	13.2	285	530
20	42	12	0.6	SE6004ZZSTMG3C4 YS	9.40	5.05	13.9	280	500
	47	14	1	SE6204ZZSTMG3C4 YS	12.8	6.65	13.2	385	450
25	47	12	0.6	SE6005ZZSTMG3C4 YS	10.1	5.85	14.5	305	400
	52	15	1	SE6205ZZSTMG3C4 YS	14.0	7.85	13.9	420	360
30	55	13	1	SE6006ZZSTMG3C4 YS	13.2	8.25	14.7	395	330
	62	16	1	SE6206ZZSTMG3C4 YS	19.5	11.3	13.9	585	300
35	62	14	1	SE6007ZZSTMG3C4 YS	15.9	10.3	14.9	475	280
	72	17	1.1	SE6207ZZSTMG3C4 YS	25.7	15.4	13.9	770	250
40	68	15	1	SE6008ZZSTMG3C4 YS	16.7	11.5	15.2	500	250
	80	18	1.1	SE6208ZZSTMG3C4 YS	29.1	17.8	14.0	875	220

Note 1) The basic load ratings are those of normal bearing (used to calculate lubrication life). The permissible radial loads can be regarded as the maximum loads applicable to individual bearings.

Applications

- Semiconductor manufacturing equipment
- Medical equipment
- LCD manufacturing equipment
- Vacuum evaporator
- Vacuum motors

3-9 High Temperature Hybrid Ceramic Bearing

This bearing has graphite (carbon) as the lubricant, which is excellent in heat resistance.

Applicable Environments

- Clean
- Magnetic field
- Vacuum
- Electric field
- High speed
- High temperature**
- Corrosive

- Temperature: -100 to 500°C
- Ambient pressure: Atmospheric pressure

Product Specifications

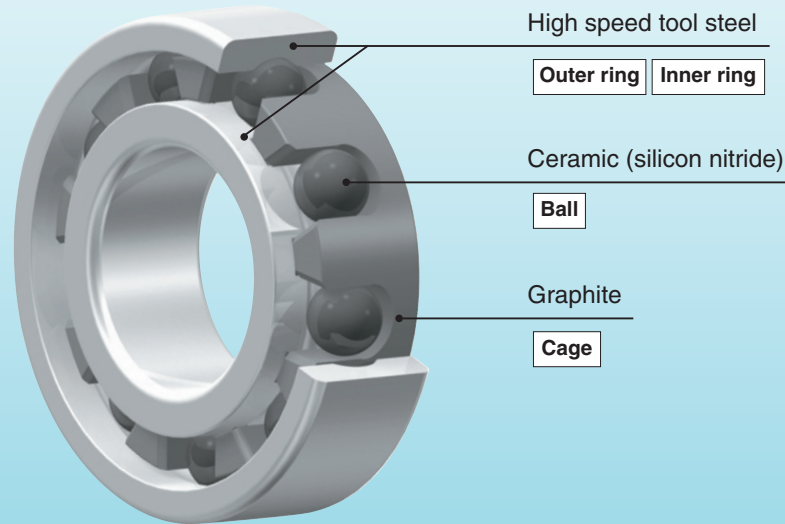

Bearing Numbering System

3 N C Basic bearing number **HT 4 GF**
 Hybrid ceramic bearing High speed tool steel Graphite cage

Dimensions Table

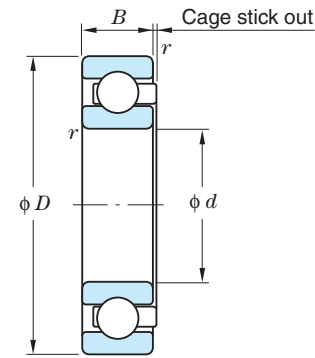

Dynamic equivalent load
 $P_r = XF_r + YF_a$
 (X and Y are as shown below.)
 Static equivalent load
 $P_{0r} = 0.6F_r + 0.5F_a$
 When P_{0r} is smaller than F_r ,
 $P_{0r} = F_r$

$\frac{f_0 F_a}{C_{0r}}$	e	$\frac{F_a}{F_r} \leq e$		$\frac{F_a}{F_r} > e$	
		X	Y	X	Y
0.172	0.19				2.30
0.345	0.22				1.99
0.689	0.26				1.71
1.03	0.28				1.55
1.38	0.30	1	0	0.56	1.45
2.07	0.34				1.31
3.45	0.38				1.15
5.17	0.42				1.04
6.89	0.44				1.00

Boundary dimensions mm				Bearing No.	Cage stick out mm (max.)	Factor f_0	Permissible radial load N	Limiting speed min ⁻¹
d	D	B	r (min.)					
6	17	6	0.3	3NC606HT4C4 GF	2	12.2	60	500
	19	6	0.3	3NC626HT4C4 GF	2	12.3	80	500
7	19	6	0.3	3NC607HT4C4 GF	2	12.3	80	500
	22	7	0.3	3NC627HT4C4 GF	2	12.4	100	490
8	22	7	0.3	3NC608HT4C4 GF	2	12.4	100	500
	24	8	0.3	3NC628HT4C4 GF	2	12.8	100	470
9	24	7	0.3	3NC609HT4C4 GF	2	12.8	100	440
	26	8	0.6	3NC629HT4C4 GF	3	12.4	135	390
9.525	22.225	7.142	0.5	3NCEE3SHT4C4 GF	2	12.8	100	410
10	26	8	0.3	3NC600HT4C4 GF	1	12.3	135	400
	30	9	0.6	3NC620HT4C4 GF	2	13.2	155	340
12	28	8	0.3	3NC6001HT4C4 GF	1	13.2	155	330
	32	10	0.6	3NC6201HT4C4 GF	3	12.3	205	310
15	32	9	0.3	3NC6002HT4C4 GF	1	13.9	170	260
	35	11	0.6	3NC6202HT4C4 GF	3	13.2	230	240
17	35	10	0.3	3NC6003HT4C4 GF	1	14.4	180	230
	40	12	0.6	3NC6203HT4C4 GF	3	13.2	285	210
20	42	12	0.6	3NC6004HT4C4 GF	2	13.9	280	200
	47	14	1	3NC6204HT4C4 GF	4	13.2	385	180
25	47	12	0.6	3NC6005HT4C4 GF	2	14.5	305	160
	52	15	1	3NC6205HT4C4 GF	3	13.9	420	140
30	55	13	1	3NC6006HT4C4 GF	3	14.7	395	130
	62	16	1	3NC6206HT4C4 GF	5	13.9	585	120
35	62	14	1	3NC6007HT4C4 GF	4	14.9	475	110
	72	17	1.1	3NC6207HT4C4 GF	7	13.9	770	100
40	68	15	1	3NC6008HT4C4 GF	3	15.2	500	100
	80	18	1.1	3NC6208HT4C4 GF	7	14.0	875	90

* Colors in the "Bearing No." column indicate the classification of the periods for delivery as shown below.
 Available from stock
 30 days after receiving an order
 45 days after receiving an order
 Determined after consultation on each inquiry

Applications

- Baking Furnace cars
- Furnace cars

3-10 Full Complement Ceramic Ball Bearing

This bearing has all components made of ceramic for use in an ultrahigh temperature environments. No cage is provided. Being an angular contact ball bearing, this bearing is normally used in pairs.

Applicable Environments

- Clean
- Vacuum
- High speed
- Corrosive
- Magnetic field
- Electric field
- High temperature

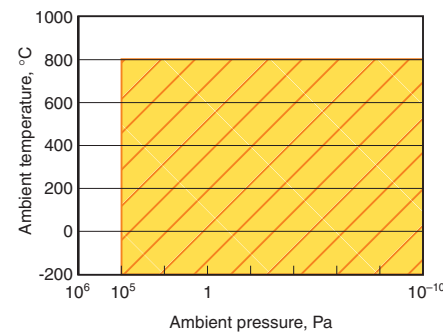

Product Specifications

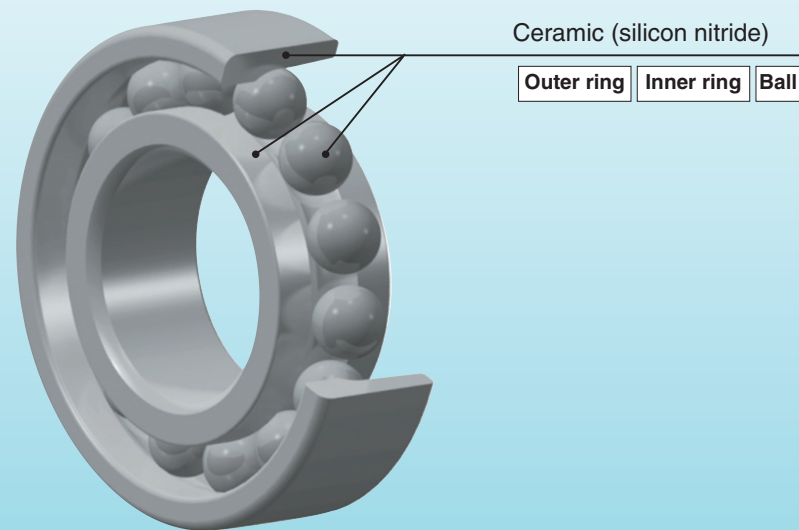

Bearing Numbering System

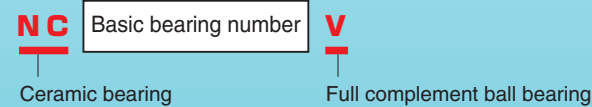

Dimensions Table

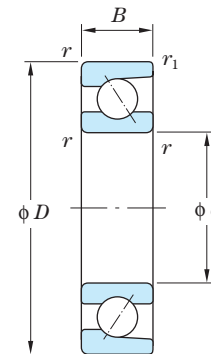

Dynamic equivalent load
 $P_r = XF_r + YF_a$
 (X and Y are as shown below.)
 Static equivalent load
 $P_{0r} = 0.6F_r + 0.5F_a$
 When P_{0r} is smaller than F_r ,
 $P_{0r} = F_r$

Contact angle	e	Single row or tandem mounting				Back to back or face to face			
		$\frac{F_a}{F_r} \leq e$		$\frac{F_a}{F_r} > e$		$\frac{F_a}{F_r} \leq e$		$\frac{F_a}{F_r} > e$	
		X	Y	X	Y	X	Y	X	Y
30°	0.80	1	0	0.39	0.76	1	0.78	0.63	1.24

* In the case of back-to-back duplex bearings and face-to-face duplex bearings, apply 2 to i. As for single row bearings and tandem duplex bearings, apply 1 to i.

Contact angle	Single row or tandem mounting		Back to back or face to face	
	X_0	Y_0	X_0	Y_0
30°	0.5	0.33	1	0.66

Boundary dimensions mm					Bearing No.	Permissible radial load N	Limiting speed min ⁻¹
d	D	B	r (min.)	r ₁ (min.)			
4	12	4	0.2	0.1	NC704V	10	500
	13	5	0.2	0.1	NC724V	15	500
5	14	5	0.2	0.1	NC705V	15	500
	16	5	0.2	0.1	NC725V	25	500
6	17	6	0.3	0.15	NC706V	20	500
	19	6	0.3	0.15	NC726V	35	500
7	19	6	0.3	0.15	NC707V	30	500
	22	7	0.3	0.15	NC727V	40	490
8	22	7	0.3	0.15	NC708V	40	500
	24	8	0.3	0.15	NC728V	40	470
9	24	7	0.3	0.15	NC709V	40	440
	26	8	0.3	0.15	NC729V	50	390
10	26	8	0.3	0.15	NC7000V	55	400
	30	9	0.6	0.3	NC7200V	60	340
12	28	8	0.3	0.15	NC7001V	60	330
	32	10	0.6	0.3	NC7201V	85	310
15	32	9	0.3	0.15	NC7002V	70	260
	35	11	0.6	0.3	NC7202V	90	240
17	35	10	0.3	0.15	NC7003V	75	230
	40	12	0.6	0.3	NC7203V	115	210
20	42	12	0.6	0.3	NC7004V	115	200
	47	14	1	0.6	NC7204V	160	180
25	47	12	1	0.6	NC7005V	125	160
	52	15	1	0.6	NC7205V	170	140
30	55	13	1	0.6	NC7006V	160	130
	62	16	1	0.6	NC7206V	235	120
35	62	14	1	0.6	NC7007V	195	110
	72	17	1.1	0.6	NC7207V	310	100
40	68	15	1	0.6	NC7008V	195	100
	80	18	1.1	0.6	NC7208V	370	90

* Colors in the "Bearing No." column indicate the classification of the periods for delivery as shown below.

- Available from stock
- 30 days after receiving an order
- 45 days after receiving an order
- Determined after consultation on each inquiry

Applications

- Baking Furnace cars
- Fans in furnaces

3-11 SK Bearing

This bearing has its components made of stainless steel, and is lubricated with lithium containing KHD grease, which is packed in adequate amounts. This bearing is suitable for use in slightly corrosive environments.

Applicable Environments

Clean

Magnetic field

Vacuum

Electric field

High speed

High temperature

Corrosive

- Temperature: - 30 to 120°C
- Ambient pressure: Atmospheric pressure
- Unsuitable for clean environments due to anticorrosive treatment.

Product Specifications

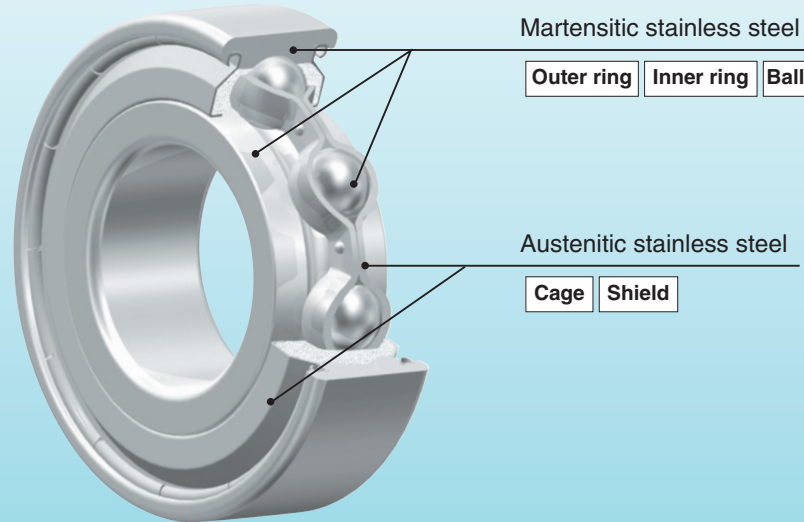

Bearing Numbering System

SK Basic bearing number ZZST YS
KHD grease packed

Grease Properties

Grease properties

	KHD grease
Thickener	Lithium soap
Base oil	Poly- α -olefin
Dropping point	203°C
Evaporation (99°C × 22h)	0.14wt%
Oil separation (100°C × 24 h)	0.1wt%
Operating temperature range	-30 to 120°C

Dimensions Table

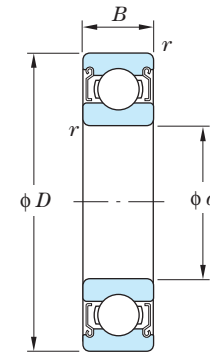

Dynamic equivalent load
 $P_r = XF_r + YF_a$
 (X and Y are as shown below.)
 Static equivalent load
 $P_{0r} = 0.6F_r + 0.5F_a$
 When P_{0r} is smaller than F_r ,
 $P_{0r} = F_r$

$\frac{f_0 F_a}{C_{0r}}$	e	$\frac{F_a}{F_r} \leq e$		$\frac{F_a}{F_r} > e$	
		X	Y	X	Y
0.172	0.19				2.30
0.345	0.22				1.99
0.689	0.26				1.71
1.03	0.28				1.55
1.38	0.30	1	0	0.56	1.45
2.07	0.34				1.31
3.45	0.38				1.15
5.17	0.42				1.04
6.89	0.44				1.00

* Colors in the "Bearing No." column indicate the classification of the periods for delivery as shown below.
 Available from stock
 30 days after receiving an order
 45 days after receiving an order
 Determined after consultation on each inquiry

Boundary dimensions mm	Bearing No.	Basic load ratings ¹⁾ kN		Factor f_0	Limiting speeds ²⁾ min ⁻¹	
		C_r	C_{0r}		Grease lubrication	Oil lubrication
10	SK6900ZZST YS	2.30	1.00	14.0	34 000	41 000
	SK6000ZZST YS	3.85	1.55	12.3	31 000	36 000
	SK6200ZZST YS	4.35	1.90	13.2	24 000	29 000
12	SK6901ZZST YS	2.45	1.15	14.5	31 000	36 000
	SK6001ZZST YS	4.35	1.90	13.2	27 000	32 000
	SK6201ZZST YS	5.75	2.45	12.3	22 000	27 000
15	SK6902ZZST YS	3.65	1.80	14.3	26 000	30 000
	SK6002ZZST YS	4.75	2.25	13.9	23 000	27 000
	SK6202ZZST YS	6.50	3.00	13.2	20 000	24 000
17	SK6903ZZST YS	3.90	2.05	14.7	23 000	28 000
	SK6003ZZST YS	5.10	2.60	14.4	21 000	25 000
	SK6203ZZST YS	8.15	3.85	13.2	17 000	21 000
20	SK6904ZZST YS	5.40	2.95	14.7	19 000	23 000
	SK6004ZZST YS	8.00	4.05	13.9	17 000	21 000
	SK6204ZZST YS	10.9	5.35	13.2	15 000	17 000
25	SK6905ZZST YS	5.95	3.65	15.4	16 000	19 000
	SK6005ZZST YS	8.55	4.65	14.5	15 000	18 000
	SK6205ZZST YS	11.9	6.30	13.9	13 000	15 000
30	SK6906ZZST YS	6.15	4.00	15.8	14 000	17 000
	SK6006ZZST YS	11.2	6.60	14.7	13 000	15 000
	SK6206ZZST YS	16.5	9.05	13.9	11 000	13 000
35	SK6907ZZST YS	9.25	6.20	15.7	12 000	14 000
	SK6007ZZST YS	13.5	8.25	14.9	11 000	13 000
	SK6207ZZST YS	21.8	12.3	13.9	9 200	11 000
40	SK6008ZZST YS	14.2	9.20	15.2	10 000	12 000
	SK6208ZZST YS	24.8	14.3	14.0	8 300	10 000

Note 1) The basic load ratings are those of bearing made from SUS440C.
 To calculate the dynamic equivalent radial loads, multiply the C_{0r} value in this table by 1.25.
 2) Bearings with a contact seal (2RS) are also available.

Applications

- Chemical equipment
- Transfer systems

3-12 Corrosion Resistant Hybrid Ceramic Bearing

This bearing uses a stainless steel variety that has excellent corrosion resistance. As the lubricant, fluoropolymer is used. It is compatible with underwater use.

Applicable Environments

- Clean
- Magnetic field
- Vacuum
- Electric field
- High speed
- High temperature
- Corrosive

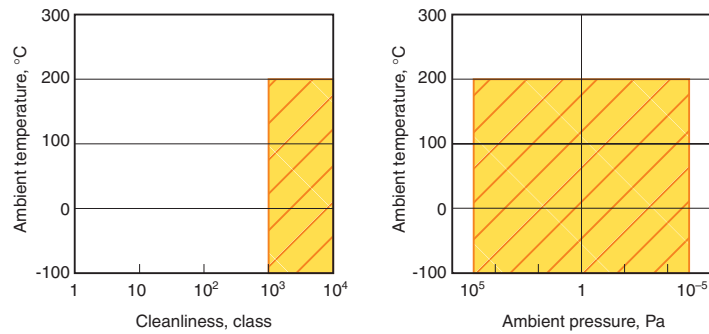

Product Specifications

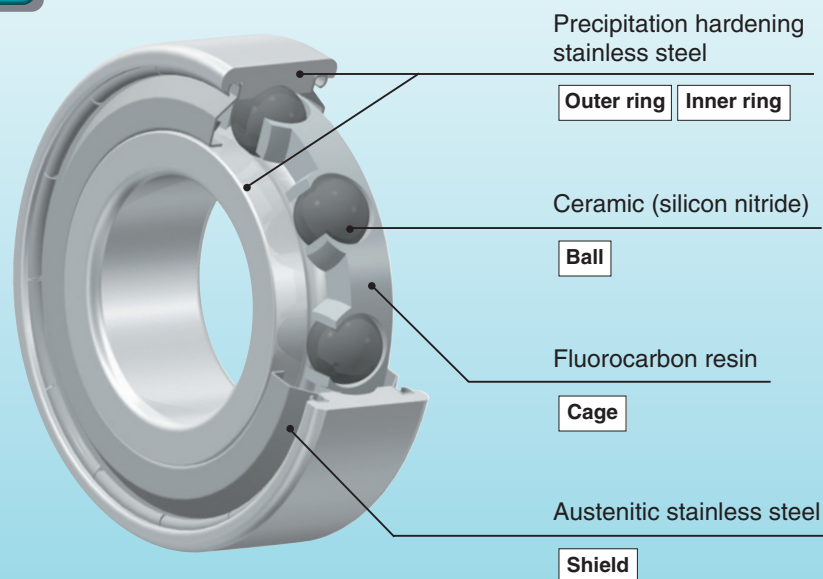

Bearing Numbering System

3NC Basic bearing number **ZZMD4FA**

Hybrid ceramic bearing Molded fluorocarbon resin cage
Precipitation hardening stainless steel

Performance

- When this Corrosion Resistant Hybrid Ceramic Bearing is used under water, its service life is determined depending on the rust and/or wear of bearing rings. The service life cannot be estimated correctly from the rating life.
- When this Corrosion Resistant Hybrid Ceramic Bearing is not used under water, select one based on the allowable radial load and limiting speed specified in the Dimensions Table.

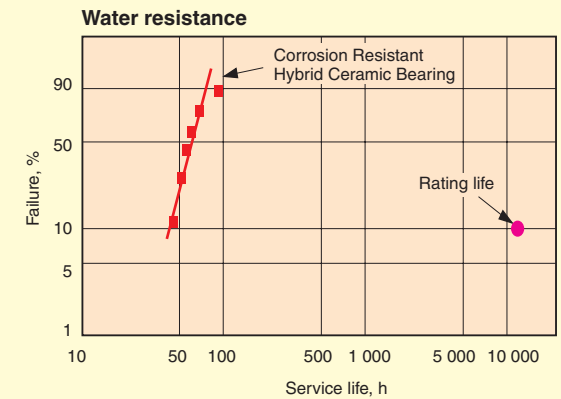

Dimensions Table

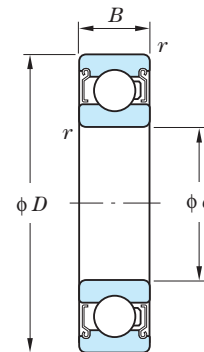

Dynamic equivalent load
 $P_r = XF_r + YF_a$
 (X and Y are as shown below.)

Static equivalent load
 $P_{0r} = 0.6F_r + 0.5F_a$
 When P_{0r} is smaller than F_r ,
 $P_{0r} = F_r$

$\frac{f_0 F_a}{C_{0r}}$	e	$\frac{F_a}{F_r} \leq e$		$\frac{F_a}{F_r} > e$	
		X	Y	X	Y
0.172	0.19				2.30
0.345	0.22				1.99
0.689	0.26				1.71
1.03	0.28				1.55
1.38	0.30	1	0	0.56	1.45
2.07	0.34				1.31
3.45	0.38				1.15
5.17	0.42				1.04
6.89	0.44				1.00

* Colors in the "Bearing No." column indicate the classification of the periods for delivery as shown below.

- Available from stock
- 30 days after receiving an order
- 45 days after receiving an order
- Determined after consultation on each inquiry

Boundary dimensions mm				Bearing No.	Factor f_0	Permissible radial load N	Limiting speed min^{-1}
d	D	B	r (min.)				
4	12	4	0.2	3NC604ZZMD4 FA	12.4	7.5	1 000
	13	5	0.2	3NC624ZZMD4 FA	12.3	10	1 000
5	14	5	0.2	3NC605ZZMD4 FA	12.3	10	1 000
	16	5	0.3	3NC625-5ZZMD4 FA	12.4	15	1 000
6	17	6	0.3	3NC606ZZMD4 FA	12.2	15	1 000
	19	6	0.3	3NC626ZZMD4 FA	12.3	20	1 000
7	19	6	0.3	3NC607ZZMD4 FA	12.3	20	1 000
	22	7	0.3	3NC627ZZMD4 FA	12.4	25	1 000
8	22	7	0.3	3NC608ZZMD4C3 FA	12.4	25	1 000
	24	8	0.3	3NC628ZZMD4 FA	12.8	25	1 000
9	24	7	0.3	3NC609ZZMD4 FA	12.8	25	1 000
	26	8	0.6	3NC629ZZMD4 FA	12.4	35	970
9.525	22.225	7.142	0.5	3NCEE3SZZMD4 FA	12.8	35	1 000
10	26	8	0.3	3NC600ZZMD4 FA	12.3	35	1 000
	30	9	0.6	3NC620ZZMD4 FA	13.2	50	860
12	28	8	0.3	3NC6001ZZMD4 FA	13.2	40	830
	32	10	0.6	3NC6201ZZMD4 FA	12.3	70	770
15	32	9	0.3	3NC6002ZZMD4 FA	13.9	45	660
	35	11	0.6	3NC6202ZZMD4 FA	13.2	75	610
17	35	10	0.3	3NC6003ZZMD4 FA	14.4	50	580
	40	12	0.6	3NC6203ZZMD4 FA	13.2	95	530
20	42	12	0.6	3NC6004ZZMD4 FA	13.9	70	500
	47	14	1	3NC6204ZZMD4 FA	13.2	130	450
25	47	12	0.6	3NC6005ZZMD4 FA	14.5	75	400
	52	15	1	3NC6205ZZMD4 FA	13.9	140	360
30	55	13	1	3NC6006ZZMD4C3 FA	14.7	95	330
	62	16	1	3NC6206ZZMD4 FA	13.9	195	300
35	62	14	1	3NC6007ZZMD4 FA	14.9	110	280
	72	17	1.1	3NC6207ZZMD4 FA	13.9	210	250
40	68	15	1	3NC6008ZZMD4 FA	15.2	135	250
	80	18	1.1	3NC6208ZZMD4 FA	14.0	230	220

Applications

- Semiconductor manufacturing equipment
- Chemical manufacturing equipment
- Food machinery
- Cleaning equipment

3-13 Ceramic Bearing

This bearing has its components made of silicon nitride ceramic and uses fluoropolymer as the lubricant. It is typically used in vacuum and corrosive environments.

Applicable Environments

- Clean
- Magnetic field
- Vacuum
- Electric field
- High speed
- High temperature
- Corrosive

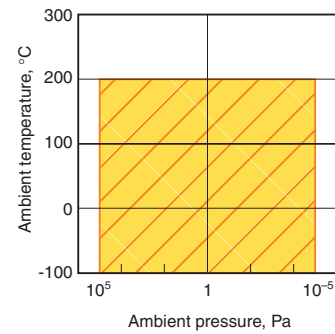
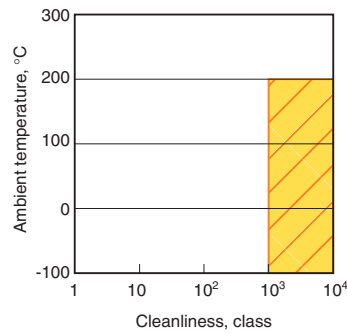

Product Specifications

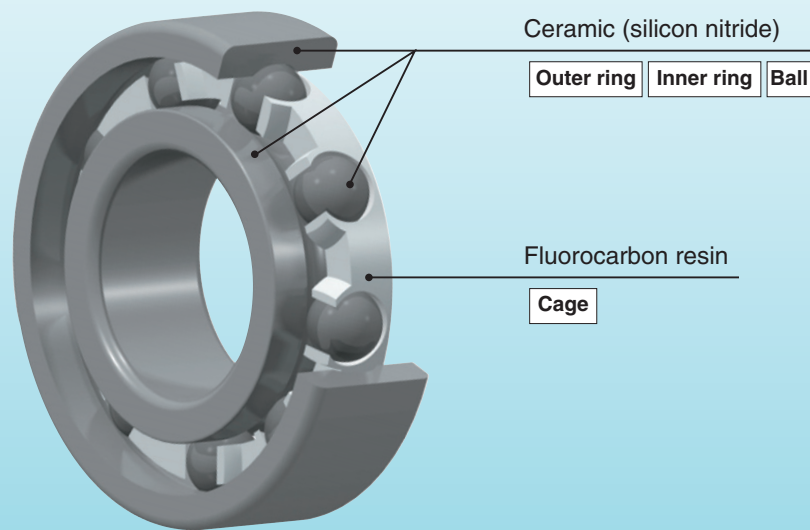

Bearing Numbering System

NC Basic bearing number **FA**
 Ceramic bearing Molded fluorocarbon resin cage

Applications

- Semiconductor manufacturing equipment
- LCD manufacturing equipment
- Semiconductor inspection equipment
- Synthetic fiber manufacturing equipment
- Canning machinery
- Ultrasonic motors

Performance

- This Ceramic Bearing can be used under water; however, when used in a liquid with poor lubrication characteristics, the load exerted on the bearing should be no higher than 10% of the bearing's basic dynamic load rating. Also note that the fatigue life of the bearing is 3% of its rating life under water.
- When this Ceramic Bearing is not used under water, select one based on the permissible radial load and limiting speed specified in the Dimensions Table.

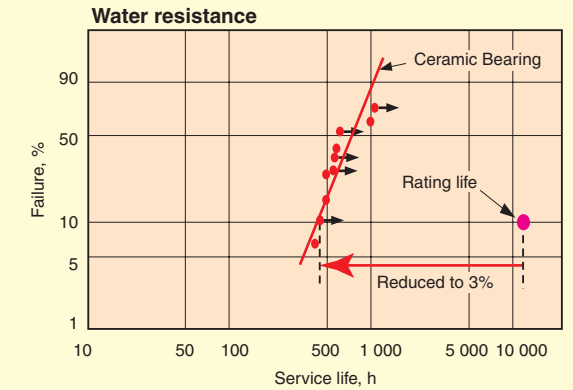

Dimensions Table

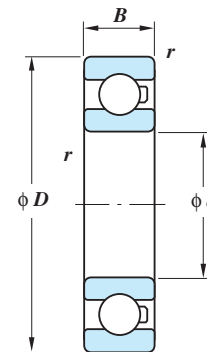

Dynamic equivalent load
 $P_r = XF_r + YF_a$
 (X and Y are as shown below.)

Static equivalent load
 $P_{0r} = 0.6F_r + 0.5F_a$
 When P_{0r} is smaller than F_r ,
 $P_{0r} = F_r$

$\frac{f_0 F_a}{C_{0r}}$	e	$\frac{F_a}{F_r} \leq e$		$\frac{F_a}{F_r} > e$	
		X	Y	X	Y
0.172	0.19				2.30
0.345	0.22				1.99
0.689	0.26				1.71
1.03	0.28				1.55
1.38	0.30	1	0	0.56	1.45
2.07	0.34				1.31
3.45	0.38				1.15
5.17	0.42				1.04
6.89	0.44				1.00

* Colors in the "Bearing No." column indicate the classification of the periods for delivery as shown below.

- Available from stock
- 30 days after receiving an order
- 45 days after receiving an order
- Determined after consultation on each inquiry

Boundary dimensions mm	Bearing No.	Basic load ratings kN		Factor f_0	Permissible radial load N	Limiting speed min ⁻¹
		C_r	C_{0r}			
4	NC604 FA	0.97	0.36	12.4	7.5	1 000
	NC624 FA	1.30	0.49	12.3	10	1 000
5	NC605 FA	1.30	0.49	12.3	10	1 000
	NC625-5 FA	1.75	0.67	12.4	15	1 000
6	NC606 FA	1.95	0.74	12.2	15	1 000
	NC626 FA	2.60	1.05	12.3	20	1 000
7	NC607 FA	2.60	1.05	12.3	20	1 000
	NC627 FA	3.30	1.35	12.4	25	1 000
8	NC608 FA	3.30	1.35	12.4	25	1 000
	NC628 FA	3.35	1.40	12.8	25	1 000
9	NC609 FA	3.35	1.40	12.8	25	1 000
	NC629 FA	4.55	1.95	12.4	35	970
9.525	NCEE3S FA	3.35	1.40	12.8	35	1 000
10	NC6000 FA	4.55	1.95	12.3	35	1 000
	NC6200 FA	5.10	2.40	13.2	50	860
12	NC6001 FA	5.10	2.40	13.2	40	830
	NC6201 FA	6.80	3.05	12.3	70	770
15	NC6002 FA	5.60	2.85	13.9	45	660
	NC6202 FA	7.65	3.75	13.2	75	610
17	NC6003 FA	6.00	3.25	14.4	50	580
	NC6203 FA	9.55	4.80	13.2	95	530
20	NC6004 FA	9.40	5.05	13.9	70	500
	NC6204 FA	12.8	6.65	13.2	130	450
25	NC6005 FA	10.1	5.85	14.5	75	400
	NC6205 FA	14.0	7.85	13.9	140	360
30	NC6006 FA	13.2	8.25	14.7	95	330
	NC6206 FA	19.5	11.3	13.9	195	300
35	NC6007 FA	15.9	10.3	14.9	110	280
	NC6207 FA	25.7	15.4	13.9	210	250
40	NC6008 FA	16.7	11.5	15.2	135	250
	NC6208 FA	29.1	17.8	14.0	230	220

3-14 Corrosion Resistant Ceramic Bearing

This bearing has its components made of corrosion resistant silicon nitride and is lubricated with fluoropolymer. This bearing can be used even in a highly corrosive solution.

Applicable Environments

- Clean
- Magnetic field
- Vacuum
- Electric field
- High speed
- High temperature
- Corrosive

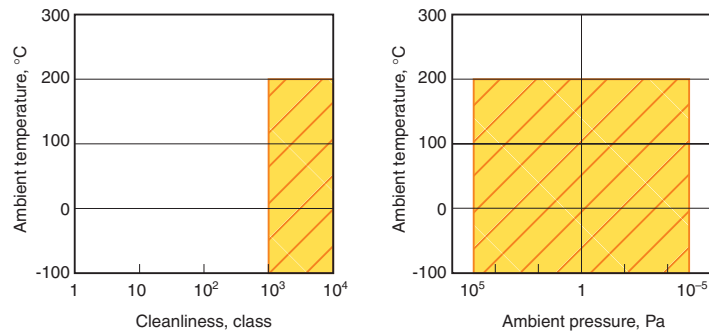

Product Specifications

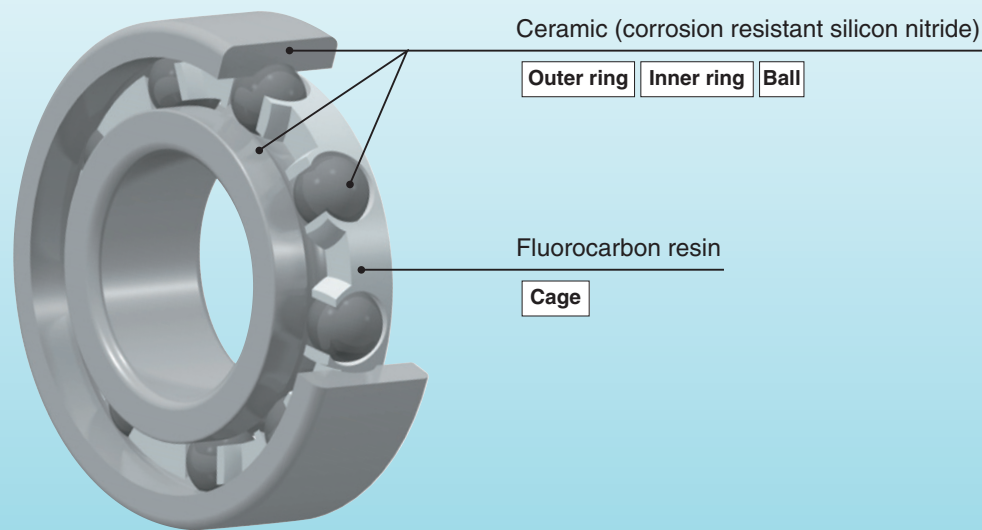

Bearing Numbering System

NCT Basic bearing number **FA**
 Corrosion resistant ceramic bearing Molded fluorocarbon resin cage

Applications

- Liquid crystal film manufacturing equipment
- Aluminum electrolytic capacitor manufacturing equipment
- Plating equipment
- Synthetic fiber manufacturing equipment
- Food container washing machine

Performance

- In an acid or alkaline solution, this bearing has a longer service life than bearings made from standard silicone nitride.

Comparison in service life after immersion in acid or alkaline solutions

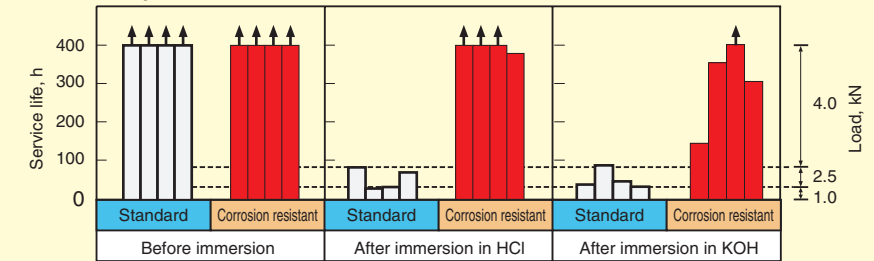

Dimensions Table

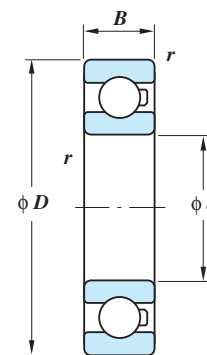

Dynamic equivalent load
 $P_r = XF_r + YF_a$
 (X and Y are as shown below.)

Static equivalent load
 $P_{0r} = 0.6F_r + 0.5F_a$
 When P_{0r} is smaller than F_r ,
 $P_{0r} = F_r$

$\frac{f_0 F_a}{C_{0r}}$	e	$\frac{F_a}{F_r} \leq e$		$\frac{F_a}{F_r} > e$	
		X	Y	X	Y
0.172	0.19				2.30
0.345	0.22				1.99
0.689	0.26				1.71
1.03	0.28				1.55
1.38	0.30	1	0	0.56	1.45
2.07	0.34				1.31
3.45	0.38				1.15
5.17	0.42				1.04
6.89	0.44				1.00

* Colors in the "Bearing No." column indicate the classification of the periods for delivery as shown below.

- Available from stock
- 30 days after receiving an order
- 45 days after receiving an order
- Determined after consultation on each inquiry

Boundary dimensions mm				Bearing No.	Factor f_0	Permissible radial load N	Limiting speed min^{-1}
d	D	B	r (min.)				
4	12	4	0.2	NCT604 FA	12.4	7.5	1 000
	13	5	0.2	NCT624 FA	12.3	10	1 000
5	14	5	0.2	NCT605 FA	12.3	10	1 000
	16	5	0.3	NCT625-5 FA	12.4	15	1 000
6	17	6	0.3	NCT606 FA	12.2	15	1 000
	19	6	0.3	NCT626 FA	12.3	20	1 000
7	19	8	0.3	NCT607 FA	12.3	20	1 000
	22	7	0.3	NCT627 FA	12.4	25	1 000
8	22	7	0.3	NCT608 FA	12.4	25	1 000
	24	8	0.3	NCT628 FA	12.8	25	1 000
9	24	7	0.3	NCT609 FA	12.8	25	1 000
	26	8	0.6	NCT629 FA	12.4	35	970
9.525	22.225	7.142	0.5	NCTEE3S FA	12.8	35	1 000
10	26	8	0.3	NCT6000 FA	12.3	35	1 000
	30	9	0.6	NCT6200 FA	13.2	50	860
12	28	8	0.3	NCT6001 FA	13.2	40	830
	32	10	0.6	NCT6201 FA	12.3	70	770
15	32	9	0.3	NCT6002 FA	13.9	45	660
	35	11	0.6	NCT6202 FA	13.2	75	610
17	35	10	0.3	NCT6003 FA	14.4	50	580
	40	12	0.6	NCT6203 FA	13.2	95	530
20	42	12	0.6	NCT6004 FA	13.9	70	500
	47	14	1	NCT6204 FA	13.2	130	450
25	47	12	0.6	NCT6005 FA	14.5	75	400
	52	15	1	NCT6205 FA	13.9	140	360
30	55	13	1	NCT6006 FA	14.7	95	330
	62	16	1	NCT6206 FA	13.9	195	300
35	62	14	1	NCT6007 FA	14.9	110	280
	72	17	1.1	NCT6207 FA	13.9	210	250
40	68	15	1	NCT6008 FA	15.2	135	250
	80	18	1.1	NCT6208 FA	14.0	230	220

3-15 High Corrosion Resistant Ceramic Bearing

This bearing uses a silicon carbide ceramic material, which is resistant to strong acids and alkalis.

Applicable Environments

- Clean
- Magnetic field
- Vacuum
- Electric field
- High speed
- High temperature
- Corrosive

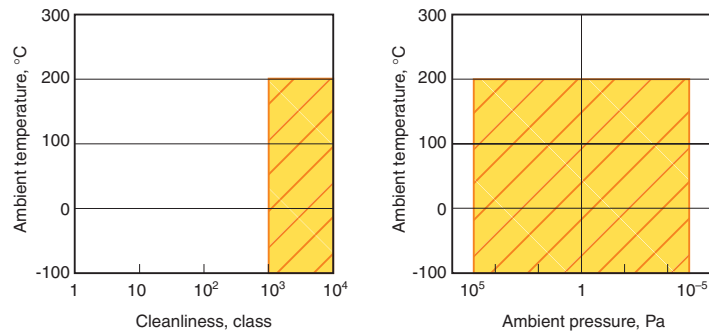

Product Specifications

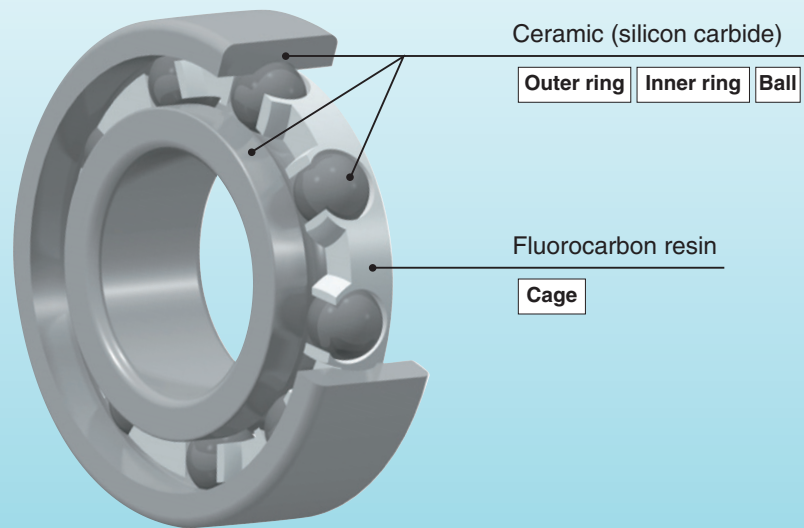

Bearing Numbering System

NCZ Basic bearing number **FA**
 High corrosion resistance ceramic bearing Molded fluorocarbon resin cage

Dimensions Table

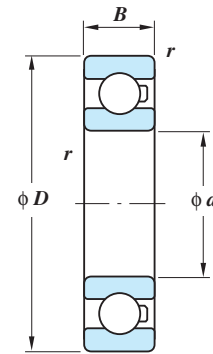

Dynamic equivalent load
 $P_r = XF_r + YF_a$
 (X and Y are as shown below.)

Static equivalent load
 $P_{0r} = 0.6F_r + 0.5F_a$
 When P_{0r} is smaller than F_r ,
 $P_{0r} = F_r$

$\frac{f_0 F_a}{C_{0r}}$	e	$\frac{F_a}{F_r} \leq e$		$\frac{F_a}{F_r} > e$	
		X	Y	X	Y
0.172	0.19				2.30
0.345	0.22				1.99
0.689	0.26				1.71
1.03	0.28				1.55
1.38	0.30	1	0	0.56	1.45
2.07	0.34				1.31
3.45	0.38				1.15
5.17	0.42				1.04
6.89	0.44				1.00

Boundary dimensions mm				Bearing No.	Factor f_0	Permissible radial load N	Limiting speed min ⁻¹
d	D	B	r (min.)				
4	12	4	0.2	NCZ604 FA	12.4	7.5	1 000
	13	5	0.2	NCZ624 FA	12.3	10	1 000
5	14	5	0.2	NCZ605 FA	12.3	10	1 000
	16	5	0.2	NCZ625 FA	12.4	15	1 000
6	17	6	0.3	NCZ606 FA	12.2	15	1 000
	19	6	0.3	NCZ626 FA	12.3	20	1 000
7	19	6	0.3	NCZ607 FA	12.3	20	1 000
	22	7	0.3	NCZ627 FA	12.4	25	1 000
8	22	7	0.3	NCZ608 FA	12.4	25	1 000
	24	8	0.3	NCZ628 FA	12.8	25	1 000
9	24	7	0.3	NCZ609 FA	12.8	25	1 000
	26	8	0.6	NCZ629 FA	12.4	35	970
9.525	22.225	7.142	0.5	NCZEE3S FA	12.8	35	1 000
10	26	8	0.3	NCZ6000 FA	12.3	35	1 000
	30	9	0.6	NCZ6200 FA	13.2	50	860
12	28	8	0.3	NCZ6001 FA	13.2	40	830
	32	10	0.6	NCZ6201 FA	12.3	70	770
15	32	9	0.3	NCZ6002 FA	13.9	45	660
	35	11	0.6	NCZ6202 FA	13.2	75	610
17	35	10	0.3	NCZ6003 FA	14.4	50	580
	40	12	0.6	NCZ6203 FA	13.2	95	530
20	42	12	1	NCZ6004 FA	13.9	70	500
	47	14	0.6	NCZ6204 FA	13.2	130	450
25	47	12	1	NCZ6005 FA	14.5	75	400
	52	15	1	NCZ6205 FA	13.9	140	360
30	55	13	1	NCZ6006 FA	14.7	95	330
	62	16	1	NCZ6206 FA	13.9	195	300
35	62	14	1	NCZ6007 FA	14.9	110	280
	72	17	1.1	NCZ6207 FA	13.9	210	250
40	68	15	1	NCZ6008 FA	15.2	135	250
	80	18	1.1	NCZ6208 FA	14.0	230	220

* Colors in the "Bearing No." column indicate the classification of the periods for delivery as shown below.

- Available from stock
- 30 days after receiving an order
- 45 days after receiving an order
- Determined after consultation on each inquiry

Applications

- Aluminum electrolytic capacitor manufacturing equipment

3-16 Non-magnetic Hybrid Ceramic Bearing

This bearing uses non-magnetic stainless steel. It includes fluoropolymer as the lubricant. This bearing can be used in a vacuum environment.

Applicable Environments

- Clean
- Vacuum
- High speed
- Corrosive
- Magnetic field
- Electric field
- High temperature

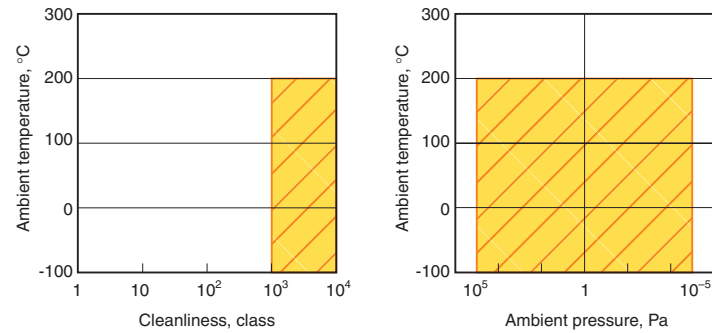

Product Specifications

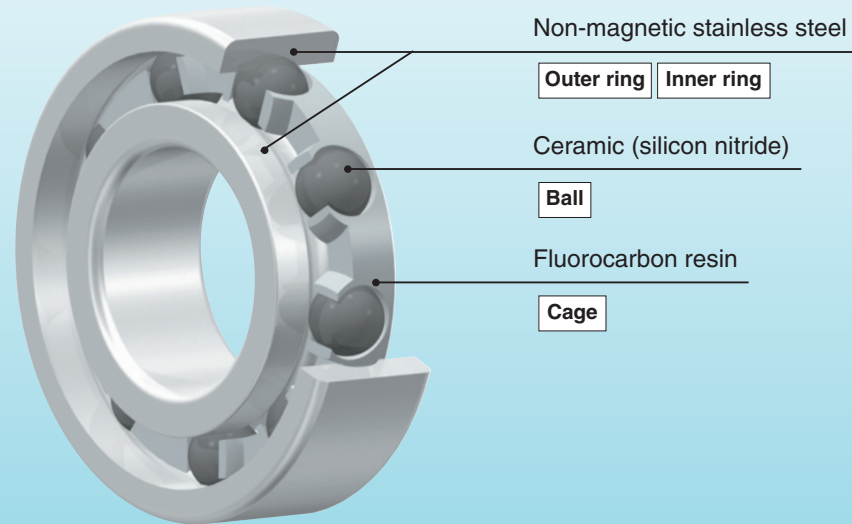

Bearing Numbering System

3NC Basic bearing number
 Hybrid ceramic bearing

YH4 FA
 Molded fluorocarbon resin cage
 Non-magnetic stainless steel

Performance

- While steel bearings experience fluctuating running torque, caused by magnetic fields, this bearing rotates at a stable torque.

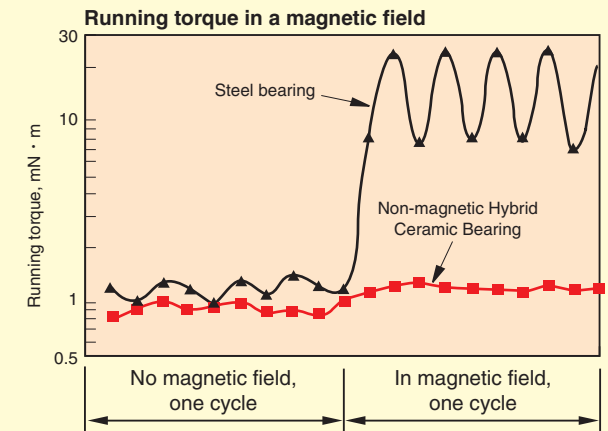

Dimensions Table

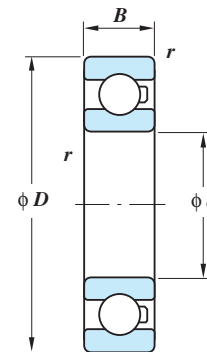

Dynamic equivalent load
 $P_r = XF_r + YF_a$
 (X and Y are as shown below.)

Static equivalent load
 $P_{0r} = 0.6F_r + 0.5F_a$
 When P_{0r} is smaller than F_r ,
 $P_{0r} = F_r$

$\frac{f_0 F_a}{C_{0r}}$	e	$\frac{F_a}{F_r} \leq e$		$\frac{F_a}{F_r} > e$	
		X	Y	X	Y
0.172	0.19				2.30
0.345	0.22				1.99
0.689	0.26				1.71
1.03	0.28				1.55
1.38	0.30	1	0	0.56	1.45
2.07	0.34				1.31
3.45	0.38				1.15
5.17	0.42				1.04
6.89	0.44				1.00

* Colors in the "Bearing No." column indicate the classification of the periods for delivery as shown below.

- Available from stock
- 30 days after receiving an order
- 45 days after receiving an order
- Determined after consultation on each inquiry

Boundary dimensions mm				Bearing No.	Factor f_0	Permissible radial load N	Limiting speed min^{-1}
d	D	B	r (min.)				
4	12	4	0.2	3NC604YH4 FA	12.4	7.5	1 000
	13	5	0.2	3NC624YH4 FA	12.3	10	1 000
5	14	5	0.2	3NC605YH4 FA	12.3	10	1 000
	16	5	0.3	3NC625-5YH4 FA	12.4	15	1 000
6	17	6	0.3	3NC606YH4 FA	12.2	15	1 000
	19	6	0.3	3NC626YH4 FA	12.3	20	1 000
7	19	6	0.3	3NC607YH4 FA	12.3	20	1 000
	22	7	0.3	3NC627YH4 FA	12.4	25	1 000
8	22	7	0.3	3NC608YH4 FA	12.4	25	1 000
	24	8	0.3	3NC628YH4 FA	12.8	25	1 000
9	24	7	0.3	3NC609YH4 FA	12.8	25	1 000
	26	8	0.6	3NC629YH4 FA	12.4	35	970
9.525	22.225	7.142	0.5	3NCEE3SYH4 FA	12.8	35	1 000
10	26	8	0.3	3NC600YH4 FA	12.3	35	1 000
	30	9	0.6	3NC620YH4 FA	13.2	50	860
12	28	8	0.3	3NC6001YH4 FA	13.2	40	830
	32	10	0.6	3NC6201YH4 FA	12.3	70	770
15	32	9	0.3	3NC6002YH4 FA	13.9	45	660
	35	11	0.6	3NC6202YH4 FA	13.2	75	610
17	35	10	0.3	3NC6003YH4 FA	14.4	50	580
	40	12	0.6	3NC6203YH4 FA	13.2	95	530
20	42	12	0.6	3NC6004YH4 FA	13.9	70	500
	47	14	1	3NC6204YH4 FA	13.2	130	450
25	47	12	0.6	3NC6005YH4 FA	14.5	75	400
	52	15	1	3NC6205YH4 FA	13.9	140	360
30	55	13	1	3NC6006YH4 FA	14.7	95	330
	62	16	1	3NC6206YH4 FA	13.9	195	300
35	62	14	1	3NC6007YH4 FA	14.9	110	280
	72	17	1.1	3NC6207YH4 FA	13.9	210	250
40	68	15	1	3NC6008YH4 FA	15.2	135	250
	80	18	1.1	3NC6208YH4 FA	14.0	230	220

Applications

- Semiconductor manufacturing equipment
- Semiconductor inspection equipment
- Canning machinery
- Superconductivity-related equipment
- Welder

3-17 Hybrid Ceramic Bearing

This bearing is a standard hybrid ceramic bearing. Lubricated with grease or oil, it can be used as an insulating bearing or high speed bearing.

Applicable Environments

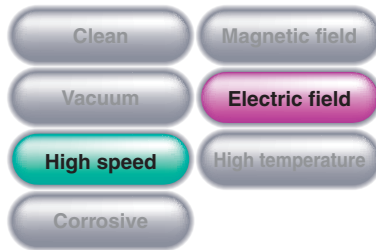

- Temperature: -30 to 120°C
- Ambient pressure: Atmospheric pressure

Product Specifications

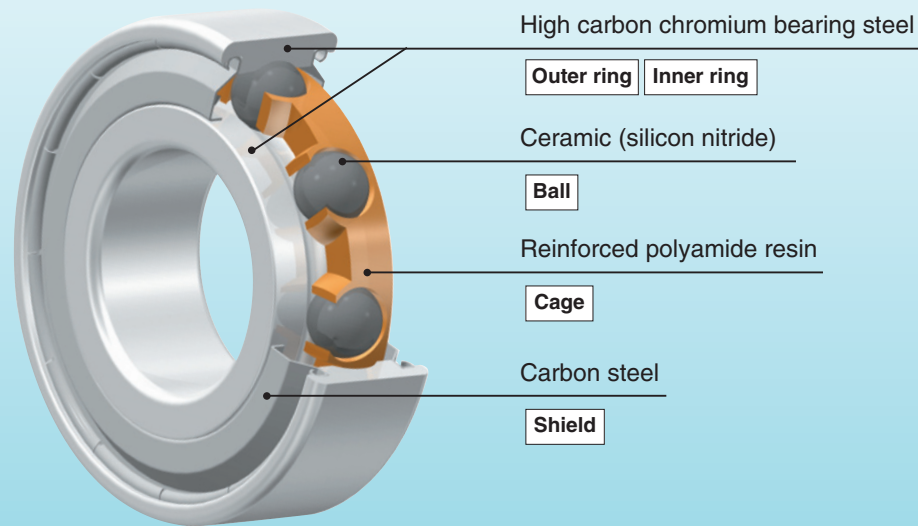

Bearing Numbering System

3NC Basic bearing number ZZ FG
Hybrid ceramic bearing

Applications

- High speed stranding machine guide rollers
- Motors

Performance

- Reduced temperature rises.
- Reduced bearing vibration.
- Good antiseizure characteristics.

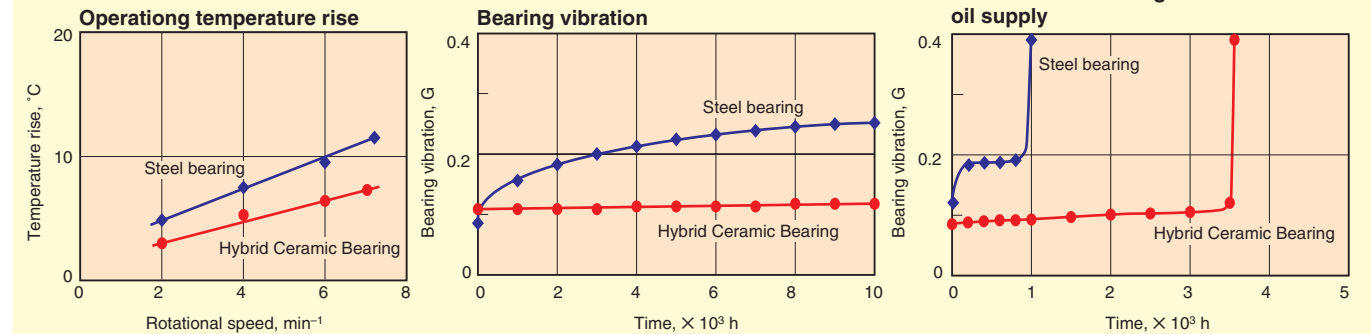

Dimensions Table

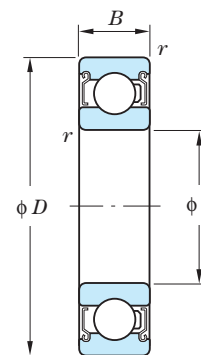

Dynamic equivalent load
 $P_r = XF_r + YF_a$
 (X and Y are as shown below.)
 Static equivalent load
 $P_{0r} = 0.6F_r + 0.5F_a$
 When P_{0r} is smaller than F_r ,
 $P_{0r} = F_r$

$\frac{f_0 F_a}{C_{0r}}$	e	$\frac{F_a}{F_r} \leq e$		$\frac{F_a}{F_r} > e$	
		X	Y	X	Y
0.172	0.19				2.30
0.345	0.22				1.99
0.689	0.26				1.71
1.03	0.28				1.55
1.38	0.30	1	0	0.56	1.45
2.07	0.34				1.31
3.45	0.38				1.15
5.17	0.42				1.04
6.89	0.44				1.00

* Colors in the "Bearing No." column indicate the classification of the periods for delivery as shown below.
 Available from stock
 30 days after receiving an order
 45 days after receiving an order
 Determined after consultation on each inquiry

Boundary dimensions mm				Bearing No.	Basic load ratings ¹⁾ kN		Factor f_0	Limiting speed min ⁻¹	
d	D	B	r (min.)		C_r	C_{0r}		Grease lubrication	Oil lubrication
4	12	4	0.2	3NC604ZZC3 FG	0.97	0.30	12.4	63 000	75 000
	13	5	0.2	3NC624ZZC3 FG	1.30	0.40	12.3	52 000	64 000
5	14	5	0.2	3NC605ZZC3 FG	1.30	0.40	12.3	60 000	72 000
	16	5	0.3	3NC625-5ZZC3 FG	1.75	0.55	12.4	48 000	58 000
6	17	6	0.3	3NC606ZZC3 FG	1.95	0.60	12.2	51 000	61 000
	19	6	0.3	3NC626ZZC3 FG	2.60	0.90	12.3	42 000	51 000
7	19	6	0.3	3NC607ZZC3 FG	2.60	0.90	12.3	48 000	56 000
	22	7	0.3	3NC627ZZC3 FG	3.30	1.15	12.4	37 000	44 000
8	22	7	0.3	3NC608ZZC3 FG	3.30	1.15	12.4	40 000	49 000
	24	8	0.3	3NC628ZZC3 FG	3.35	1.20	12.8	33 000	42 000
9	24	7	0.3	3NC609ZZC3 FG	3.35	1.20	12.8	39 000	48 000
	26	8	0.6	3NC629ZZC3 FG	4.55	1.65	12.4	32 000	39 000
9.525	22.225	7.142	0.5	3NCEE3SZZC3 FG	3.35	1.20	12.8	39 000	48 000
10	26	8	0.3	3NC600ZZC3 FG	4.55	1.65	12.3	37 000	43 000
	30	9	0.6	3NC620ZZC3 FG	5.10	2.05	13.2	28 000	34 000
12	28	8	0.3	3NC6001ZZC3 FG	5.10	2.05	13.2	32 000	38 000
	32	10	0.6	3NC6201ZZC3 FG	6.80	2.60	12.3	26 000	32 000
15	32	9	0.3	3NC6002ZZC3 FG	5.60	2.40	13.9	27 000	32 000
	35	11	0.6	3NC6202ZZC3 FG	7.65	3.15	13.2	24 000	28 000
17	35	10	0.3	3NC6003ZZC3 FG	6.00	2.75	14.4	25 000	30 000
	40	12	0.6	3NC6203ZZC3 FG	9.55	4.10	13.2	20 000	25 000
20	42	12	0.6	3NC6004ZZC3 FG	9.40	4.30	13.9	20 000	25 000
	47	14	1	3NC6204ZZC3 FG	12.8	5.65	13.2	18 000	20 000
25	47	12	0.6	3NC6005ZZC3 FG	10.1	4.95	14.5	18 000	21 000
	52	15	1	3NC6205ZZC3 FG	14.0	6.70	13.9	15 000	18 000
30	55	13	1	3NC6006ZZC3 FG	13.2	7.00	14.7	15 000	18 000
	62	16	1	3NC6206ZZC3 FG	19.5	9.60	13.9	13 000	15 000
35	62	14	1	3NC6007ZZC3 FG	15.9	8.75	14.9	13 000	15 000
	72	17	1.1	3NC6207ZZC3 FG	25.7	13.1	13.9	11 000	13 000
40	68	15	1	3NC6008ZZC3 FG	16.7	9.80	15.2	12 000	14 000
	80	18	1.1	3NC6208ZZC3 FG	29.1	15.2	14.0	9 900	12 000

Note 1) The basic load ratings are those of the Hybrid Ceramic Bearing. To calculate its dynamic equivalent radial load, multiply the C_{0r} values in this table by 1.176.

4 K Series Full Complement Hybrid Ceramic Ball Bearing

This bearing is based on the K series super thin section ball bearing, which is widely used in industrial robots. Provided with some adaptations, this bearing is compatible with clean or vacuum environments. It uses fluorinated KDL grease as the standard lubricant.

Applicable Environments

- Clean
- Vacuum
- High speed
- Corrosive
- Magnetic field
- Electric field
- High temperature

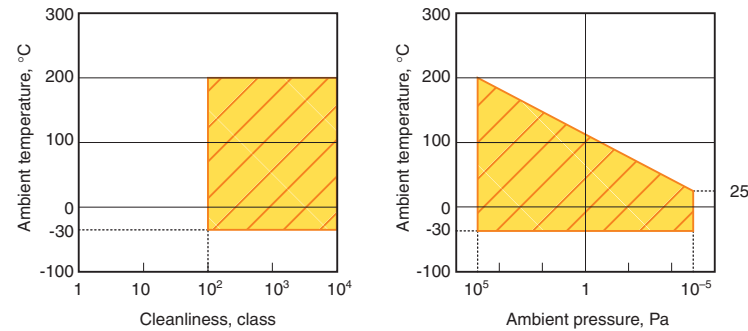

Product Specifications

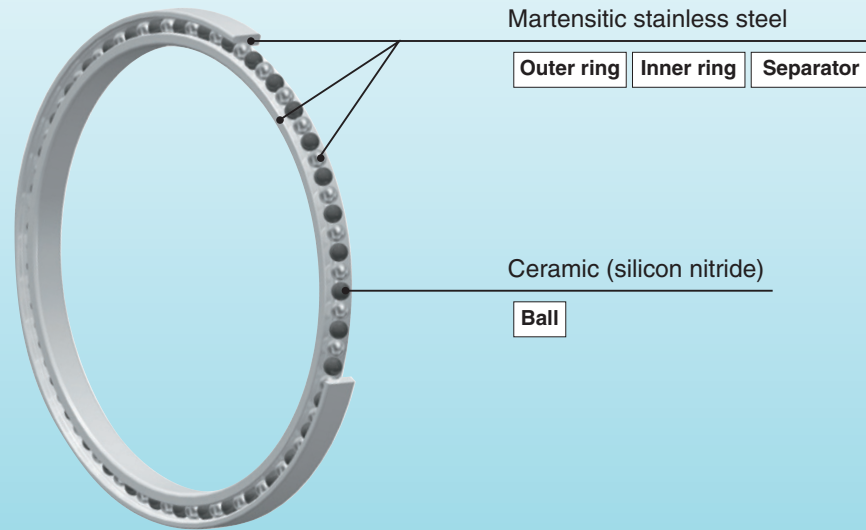

Bearing Numbering System

3NC Basic bearing number Hybrid ceramic bearing
VST-1 Full complement type

Applications

- Wafer transfer robot
- Semiconductor manufacturing equipment
- LCD manufacturing equipment

Types and Dimension Series

- The K series super thin section ball bearing is available in three types: deep groove type, angular contact type and four point contact type.
 - The cross section can be selected from among three sizes: 4.762, 6.35 and 7.938 (mm).
 - For use in a clean or vacuum environment, the angular contact type, which has stainless steel balls and ceramic balls alternately, is available in series.
- Products not listed in the Dimensions Table are available to order. Please consult JTEKT.

Dimension series code	Cross sectional dimension B = E mm	Bearing type code			Bore dia. mm
		C (Deep groove type)	A (Angular contact type)	X (4 point contact type)	
T	4.762	KTC	KTA	KTX	25.4, 38.1
A	6.35	KAC	KAA	KAX	50.8 to 88.9
B	7.938	KBC	KBA	KBX	

Dimensions Table

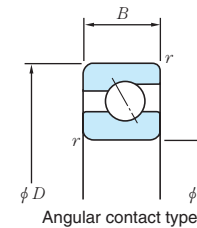

Dynamic equivalent load
 $P_r = XF_r + YF_a$
 (X and Y are as shown below.)
 Static equivalent load
 $P_{0r} = 0.6F_r + 0.5F_a$
 When P_{0r} is smaller than F_r ,
 $P_{0r} = F_r$

Contact angle	e	Single row or tandem mounting				Back to back or face to face			
		$\frac{F_a}{F_r} \leq e$		$\frac{F_a}{F_r} > e$		$\frac{F_a}{F_r} \leq e$		$\frac{F_a}{F_r} > e$	
		X	Y	X	Y	X	Y	X	Y
30°	0.80	1	0	0.39	0.76	1	0.78	0.63	1.24

Contact angle	Single row or tandem mounting		Back to back or face to face	
	X ₀	Y ₀	X ₀	Y ₀
30°	0.5	0.33	1	0.66

Boundary dimensions mm	Bearing No.	Basic load ratings ¹⁾ kN	
		C _r	C _{0r}
25.4	3NCKTA010VST-1	2.05	1.20
38.1	3NCKTA015VST-1	2.35	1.65
50.8	3NCKAA020VST-1	3.90	2.95
	3NCKBA020VST-1	5.40	3.80
63.5	3NCKAA025VST-1	4.20	3.55
	3NCKBA025VST-1	5.85	4.60
76.2	3NCKAA030VST-1	4.50	4.20
	3NCKBA030VST-1	6.25	5.45
88.9	3NCKAA035VST-1	4.80	4.90
	3NCKBA035VST-1	6.60	6.25

Note 1) The basic load ratings are those of bearing made from SUS440C.

* Colors in the "Bearing No." column indicate the classification of the periods for delivery as shown below.

- Available from stock
- 30 days after receiving an order
- 45 days after receiving an order
- Determined after consultation on each inquiry

2 5 Linear Motion Bearings

5-1 Linear Motion Ball Bearings for Use in Extreme Special Environments

The linear motion ball bearings are a high precision product that moves linearly in axial directions while having rolling contact with the shaft. Having balls, retainer and shields housed in an external cylinder, this compact bearing moves linearly without limit to the stroke distance.

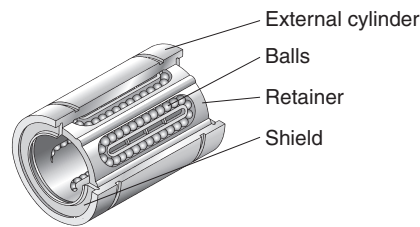

Bearing Types

		DL Linear Motion Ball Bearing	Clean Pro Linear Motion Ball Bearing	MG Linear Motion Ball Bearing	MO Linear Motion Ball Bearing	Hybrid Ceramic Linear Motion Ball Bearing
Material	External cylinder	Martensitic stainless steel				Martensitic stainless steel
	Balls					Silicon nitride
	Retainer	Austenitic stainless steel				Austenitic stainless steel
	Shields	Precipitation hardened stainless steel				Precipitation hardened stainless steel
Lubricant	KDL grease	Clean pro coating over the entire surface of all components	Silver ion plated balls	Molybdenum disulfide coated on the retainer surface	(Remark)	

Remark) Hybrid Ceramic Linear Motion Ball Bearings with grease lubrication or with Clean Pro coating are also available. Consult JTEKT regarding the applications of these bearings.

Applicable Environments

	DL Linear Motion Ball Bearing	Clean Pro Linear Motion Ball Bearing	MG Linear Motion Ball Bearing	MO Linear Motion Ball Bearing	Hybrid Ceramic Linear Motion Ball Bearing
Cleanliness	Class 100	Class 10	—	—	—
Temperature °C	-30 to 200	-100 to 200	-200 to 300	-100 to 300	-30 to 300
Ambient pressure Pa	Normal to 10 ⁻⁵	Normal to 10 ⁻⁵	10 ⁻³ to 10 ⁻¹⁰	Normal to 10 ⁻⁵	Normal pressure

Performance

Comparison in lubrication life

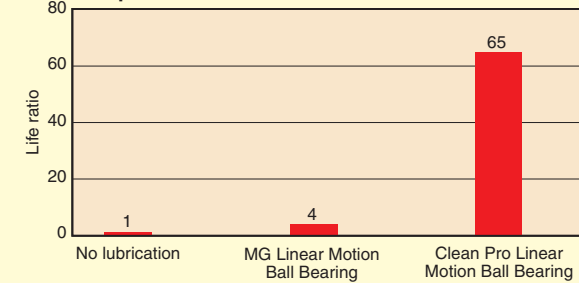

Test conditions

Tested bearing	φ 10 × φ 19 × 29mm (bore dia. X outside dia. X width)
Ambience	Atmospheric air, class 10
Temperature	Room temp.
Load	50N
Speed	30mm/s

Bearing Numbering System

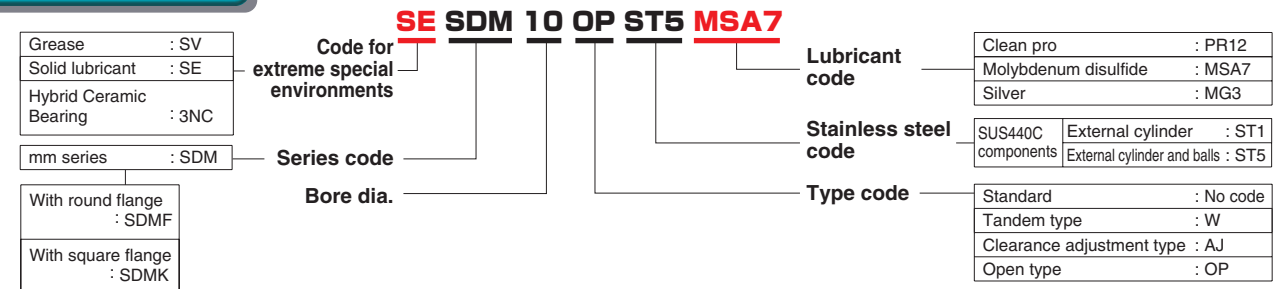

- Note 1) This catalogue does not contain the dimensions tables of mm-series linear motion ball bearings (for Europe). Contact JTEKT for the dimensions.
 2) The clearance adjustment type (AJ) and open type (OP) are not compatible with tandem type and flanged type.

Bearing Mounting

- Linear motion ball bearings are constructed not to allow rotary motion but allow linear motion only. These bearings should carry loads evenly throughout their entire stroke; therefore, when the bearing is subjected to bending loads, mount two bearings at a distance on a shaft, or use a tandem type linear motion ball bearing.
- When installing a linear motion bearing in a housing, press one end face of the external cylinder into the housing, taking care not to push or hit the shield, or insert the bearing softly using a jig as shown in the figure at right. When inserting a shaft, check the shaft for burrs or indentations in advance and insert it slowly so as not to deform the shaft. Chamfer the shaft end faces.
- To support linear motion bearings built in a single housing on a set of two or more shafts, adjust the parallelism of the shafts while checking the smooth motion of the bearings. Imperfectly paralleled shafts may disturb smooth motion of the bearings or shorten their service life.

Jig for bearing installation in housing

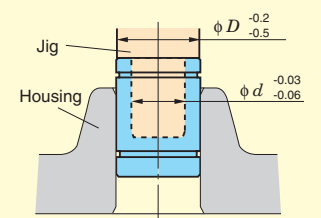

Typical use on two shafts

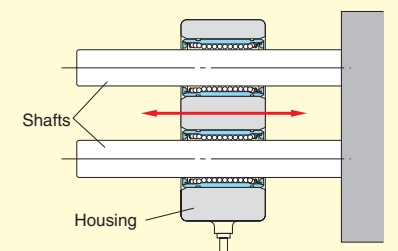

Dimensions Table

SDM Series

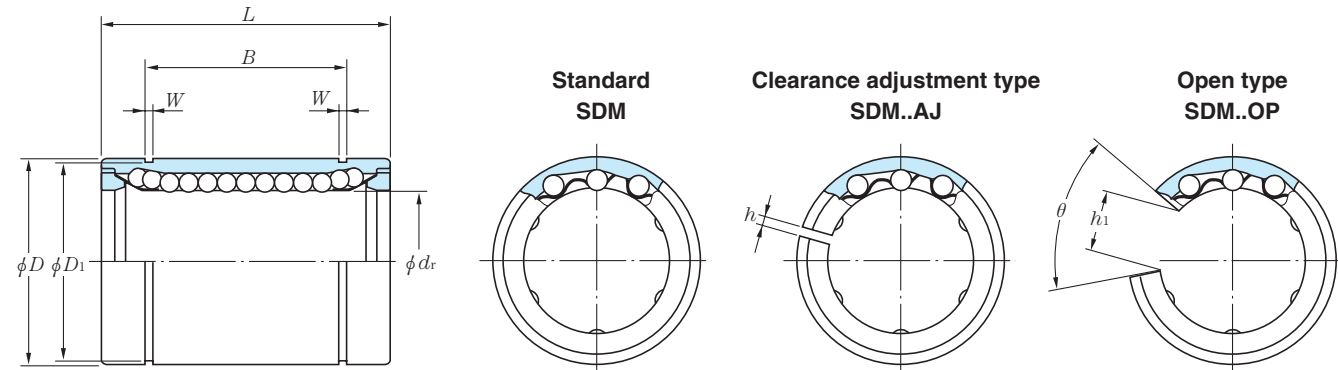

Shaft dia. d_r mm	Standard			Clearance adjustment type (AJ)			Open type (OP)			Boundary dimensions, mm											Basic load rating			
	Basic bearing No.	No. of ball rows	Mass g	Basic bearing No.	No. of ball rows	Mass g	Basic bearing No.	No. of ball rows	Mass g	d_r	Tolerance μm	D	Tolerance μm	L	Tolerance μm	B	Tolerance μm	W	D_1	h	h_1	θ (degree)	C_N	C_0_N
3	SDM 3		1.4	-	-	-	-	-	3	0	7	0	10										69	105
4	SDM 4		2	-	-	-	-	-	4	-8	8	-9	12	-120									88	127
5	SDM 5		4	-	-	-	-	-	5		10		15		10.2		1.1	9.6					167	206
6	SDM 6		8.5	-	-	-	-	-	6		12		19		13.5		1.1	11.5					206	265
8	SDM 8S		11	-	-	-	-	-	8		15	0	17		11.5		1.1	14.3					176	216
8	SDM 8		17	-	-	-	-	-	8		15		24		17.5		1.1	14.3					274	392
10	SDM10		36	-	-	-	-	-	10	0	19	-9	29		22	0	1.3	18					372	549
12	SDM12		42	SDM12 AJ		41	SDM12 OP		12	0	21	0	30	-200	23		1.3	20	1.5	8	80	510	784	
13	SDM13		49	SDM13 AJ	4	48	SDM13 OP	3	13	-13	23		32		23		1.3	22	1.5	9	80	510	784	
16	SDM16		76	SDM16 AJ		75	SDM16 OP		16		28		37		26.5		1.6	27	1.5	11	80	774	1 180	
20	SDM20		100	SDM20 AJ	5	98	SDM20 OP	4	20		32		42		30.5		1.6	30.5	1.5	11	60	882	1 370	
25	SDM25		240	SDM25 AJ		237	SDM25 OP		25	0	40	0	59		41		1.85	38	2	12	50	980	1 570	
30	SDM30		270	SDM30 AJ		262	SDM30 OP		30	-10	45	-16	64		44.5		1.85	43	2.5	15	50	1 570	2 740	
35	SDM35		425	SDM35 AJ		420	SDM35 OP		35		52		70		49.5		2.1	49	2.5	17	50	1 670	3 140	
40	SDM40		654	SDM40 AJ	6	640	SDM40 OP	5	40	0	60	0	80	-300	60.5	0	2.1	57	3	20	50	2 160	4 020	
50	SDM50		1 700	SDM50 AJ		1 680	SDM50 OP		50	-12	80	-19	100		74		2.6	76.5	3	25	50	3 820	7 940	
60	SDM60		2 000	SDM60 AJ		1 980	SDM60 OP		60	0	90	0	110		85		3.15	86.5	3	30	50	4 700	10 000	

SDM..W series (Tandem type)

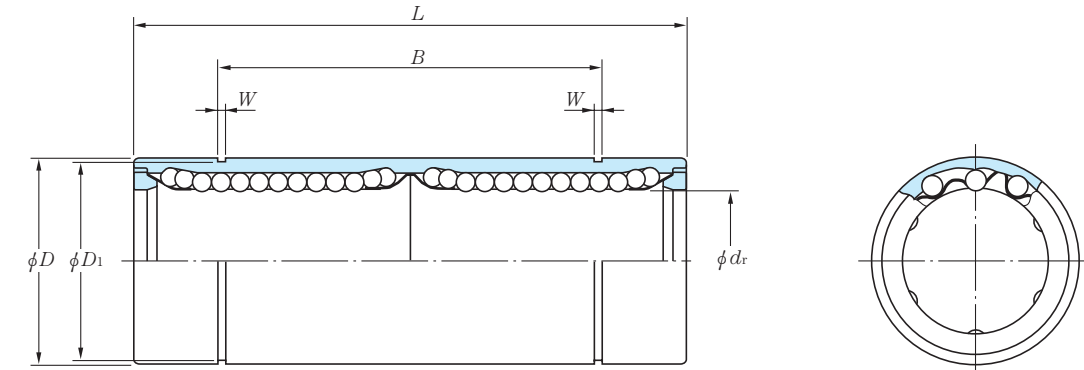

Shaft dia. d_r mm	Basic bearing No.	Mass g	Boundary dimensions, mm											Basic load rating	
			d_r	Tolerance μm	D	Tolerance μm	L	Tolerance μm	B	Tolerance μm	W	D_1	C_N	C_0_N	
5	SDM 5W	11	5		10	0	28		20.4		1.1	9.6	265	412	
6	SDM 6W	16	6		12	0	35		27		1.1	11.5	323	530	
8	SDM 8W	31	8	0	15	-13	45		35		1.1	14.3	431	784	
10	SDM10W	62	10	-10	19		55	0	44	-300	1.3	18	588	1 100	
12	SDM12W	80	12		21	0	57		46		1.3	20	813	1 570	
13	SDM13W	90	13		23	-16	61		46		1.3	22	813	1 570	
16	SDM16W	145	16		28		70		53		1.6	27	1 230	2 350	
20	SDM20W	180	20		32		80		61		1.6	30.5	1 400	2 740	
25	SDM25W	440	25	0	40	-19	112		82		1.85	38	1 560	3 140	
30	SDM30W	480	30		45		123		89		1.85	43	2 490	5 490	
35	SDM35W	795	35		52		135		99		2.1	49	2 650	6 270	
40	SDM40W	1 170	40	0	60	-22	151	0	121	-400	2.1	57	3 430	8 040	
50	SDM50W	3 100	50		80		192		148		2.6	76.5	6 080	15 900	
60	SDM60W	3 500	60	0	90	-25	209		170		3.15	86.5	7 550	20 000	

SDMF series (with round flange)
SDMK series (with square flange)

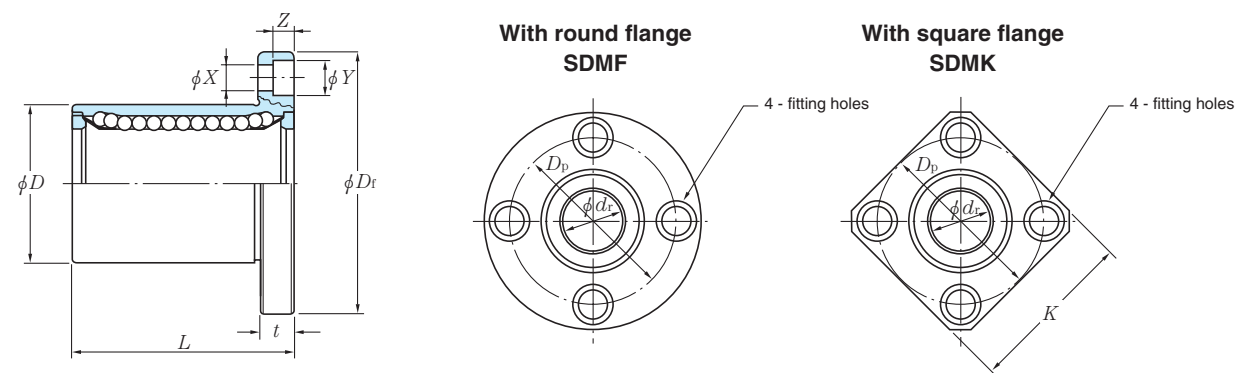

SDMF..W series (tandem type, with round flange)
SDMK..W series (tandem type, with square flange)

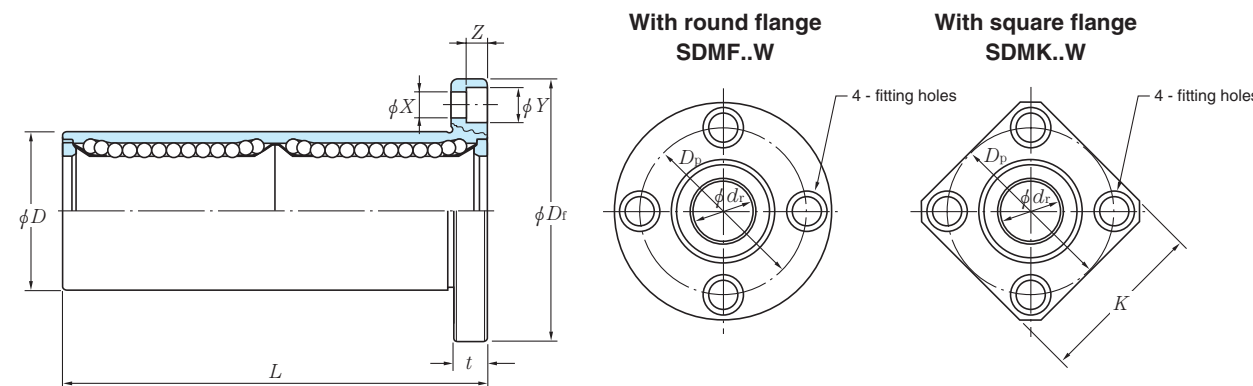

Shaft dia. d_r mm	Basic bearing No.	Mass g	Boundary dimensions, mm											Eccentricity (max.) μm	Square-ness (max.) μm	Basic load rating			
			d_r	Tolerance μm	D	Tolerance μm	L	Tolerance μm	D_i	K	t	D_p	X			Y	Z	C N	C_0 N
6	SDMF 6 SDMK 6	24 18	6		12		19		28	22	5	20	3.5	6	3.1			206	265
8	SDMF 8S SDMK 8S	32 24	8		15	0 -13	17		32	25	5	24	3.5	6	3.1			176	216
8	SDMF 8 SDMK 8	37 29	8		15		24		32	25	5	24	3.5	6	3.1			274	392
10	SDMF10 SDMK10	72 52	10	0 -9	19		29		40	30	6	29	4.5	7.5	4.1	12	12	372	549
12	SDMF12 SDMK12	76 57	12		21	0 -16	30		42	32	6	32	4.5	7.5	4.1			510	784
13	SDMF13 SDMK13	88 72	13		23		32		43	34	6	33	4.5	7.5	4.1			510	784
16	SDMF16 SDMK16	120 104	16		28		37		48	37	6	38	4.5	7.5	4.1			774	1 180
20	SDMF20 SDMK20	180 145	20		32		42	± 300	54	42	8	43	5.5	9	5.1			882	1 370
25	SDMF25 SDMK25	340 300	25	0 -10	40	0 -19	59		62	50	8	51	5.5	9	5.1	15	15	980	1 570
30	SDMF30 SDMK30	470 375	30		45		64		74	58	10	60	6.6	11	6.1			1 570	2 740
35	SDMF35 SDMK35	650 560	35		52		70		82	64	10	67	6.6	11	6.1			1 670	3 140
40	SDMF40 SDMK40	1 060 880	40	0 -12	60	0 -22	80		96	75	13	78	9	14	8.1	20	20	2 160	4 020
50	SDMF50 SDMK50	2 200 2 000	50		80		100		116	92	13	98	9	14	8.1			3 820	7 940
60	SDMF60 SDMK60	3 000 2 560	60	0 -15	90	0 -25	110		134	106	18	112	11	17	11.1	25	25	4 700	10 000

Shaft dia. d_r mm	Basic bearing No.	Mass g	Boundary dimensions, mm											Eccentricity (max.) μm	Square-ness (max.) μm	Basic load rating			
			d_r	Tolerance μm	D	Tolerance μm	L	Tolerance μm	D_i	K	t	D_p	X			Y	Z	C N	C_0 N
6	SDMF 6W SDMK 6W	31 25	6		12	0 -13	35		28	22	5	20	3.5	6	3.1			323	530
8	SDMF 8W SDMK 8W	51 43	8		15		45		32	25	5	24	3.5	6	3.1			431	784
10	SDMF10W SDMK10W	98 78	10	0 -10	19		55		40	30	6	29	4.5	7.5	4.1	15	15	588	1 100
12	SDMF12W SDMK12W	110 90	12		21	0 -16	57		42	32	6	32	4.5	7.5	4.1			813	1 570
13	SDMF13W SDMK13W	130 108	13		23		61		43	34	6	33	4.5	7.5	4.1			813	1 570
16	SDMF16W SDMK16W	190 165	16		28		70		48	37	6	38	4.5	7.5	4.1			1 230	2 350
20	SDMF20W SDMK20W	260 225	20		32		80	± 300	54	42	8	43	5.5	9	5.1			1 400	2 740
25	SDMF25W SDMK25W	540 500	25	0 -12	40	0 -19	112		62	50	8	51	5.5	9	5.1	20	20	1 560	3 140
30	SDMF30W SDMK30W	680 590	30		45		123		74	58	10	60	6.6	11	6.1			2 490	5 490
35	SDMF35W SDMK35W	1 020 930	35		52		135		82	64	10	67	6.6	11	6.1			2 650	6 270
40	SDMF40W SDMK40W	1 570 1 380	40	0 -15	60	0 -22	151		96	75	13	78	9	14	8.1	25	25	3 430	8 040
50	SDMF50W SDMK50W	3 600 3 400	50		80		192		116	92	13	98	9	14	8.1			6 080	15 900
60	SDMF60W SDMK60W	4 500 4 060	60	0 -20	90	0 -25	209		134	106	18	112	11	17	11.1	30	30	7 550	20 000

5-2 Linear Way Bearing Units for Use in Extreme Special Environments

The Linear Way Bearing Units have a slide unit in which balls circulate, allowing the slide unit to move linearly on the track rail without limit. High precision linear motion can be obtained easily by fixing the slide unit and track rail with bolts.

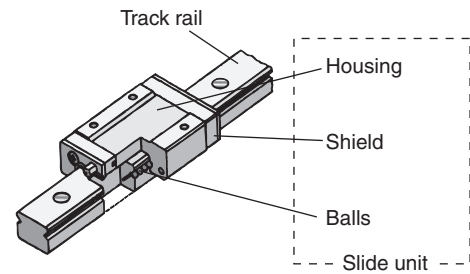

Bearing Types

	DL Linear Way Bearing Unit	Clean Pro Linear Way Bearing Unit	Hybrid Ceramic Linear Way Bearing Unit
Material	Housing	Martensitic stainless steel	Martensitic stainless steel
	Track rail		Silicon nitride
	Balls		Austenitic stainless steel
	Shields	(Remark)	
Lubricant	KDL grease	Clean pro coating over the entire surface of all components	(Remark)

Remark) Hybrid Ceramic Linear Way Bearing Unit with grease lubrication or with Clean Pro coating are also available. Consult JTEKT regarding the use of these bearings.

Applicable Environments

	DL Linear Way Bearing Unit	Clean Pro Linear Way Bearing Unit	Hybrid Ceramic Linear Way Bearing Unit
Cleanliness	Class 100	Class 10	-
Temperature °C	- 30 to 200	- 100 to 200	- 30 to 200
Ambient pressure Pa	Normal to 10 ⁻⁵	Normal to 10 ⁻⁵	Normal pressure

Performance

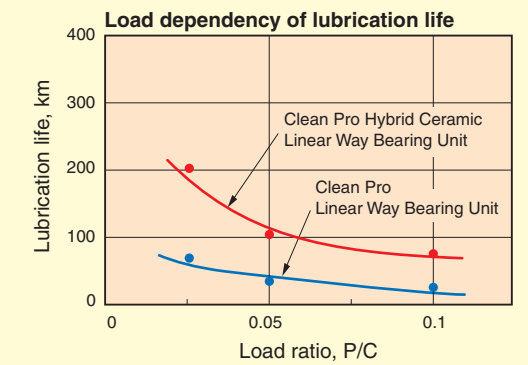
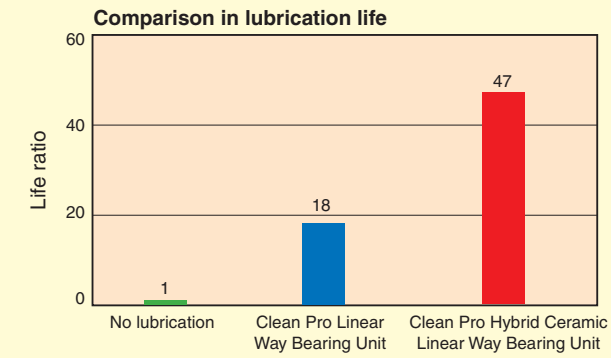

Bearing Numbering System

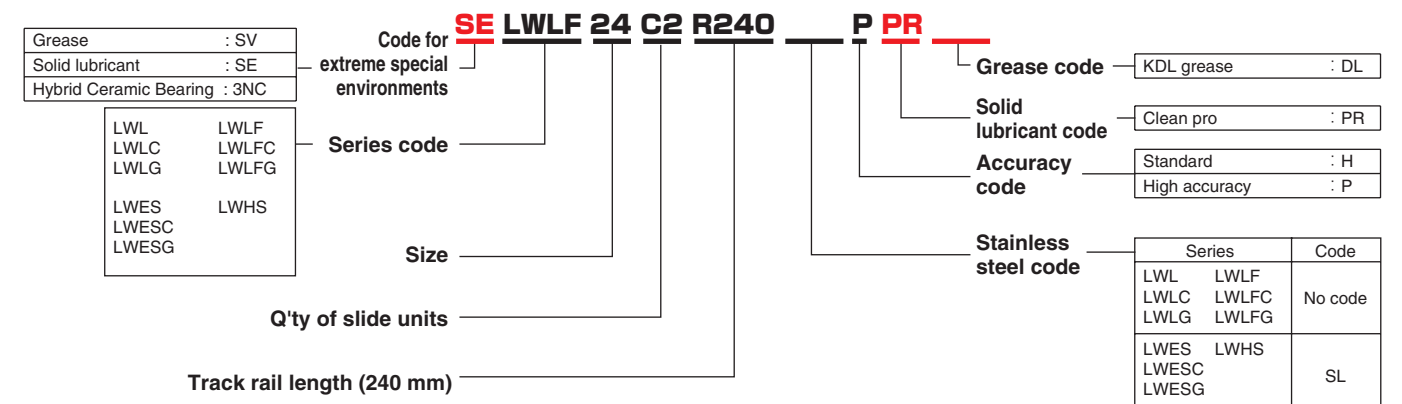

Tolerance (before surface treatment)

Unit: mm

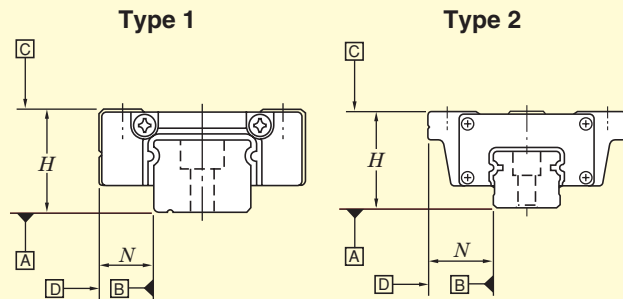

Item	LWL LWLC LWLG (Type 1)	LWLF LWLFC LWLFG (Type 1)	LWES LWESC LWESG (Type 2)	LWHS LWESG (Type 2)
Tolerance of <i>H</i>	± 0.020	± 0.020	± 0.040	± 0.040
Variation of <i>H</i> ¹⁾	0.015 max.	0.015 max.	0.015 max.	0.015 max.
Tolerance of <i>N</i>	± 0.025	± 0.025	± 0.050	± 0.050
Variation of <i>N</i> ¹⁾	0.020 max.	0.020 max.	0.020 max.	0.020 max.
Degree of running parallelism of plane <i>C</i> to plane <i>A</i>	Fig. 5-1		Fig. 5-2	
Degree of running parallelism of plane <i>D</i> to plane <i>B</i>	Fig. 5-1		Fig. 5-2	

Note 1) The variation refers to the dimensional difference between the slide units built into the same track rail.
Remark) The preload is null or negligible.

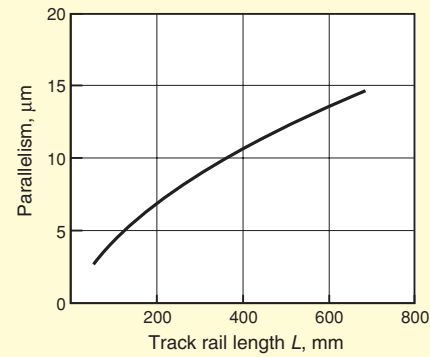

Fig. 5-1 Running parallelism of Linear Way Bearing Unit (Type 1)

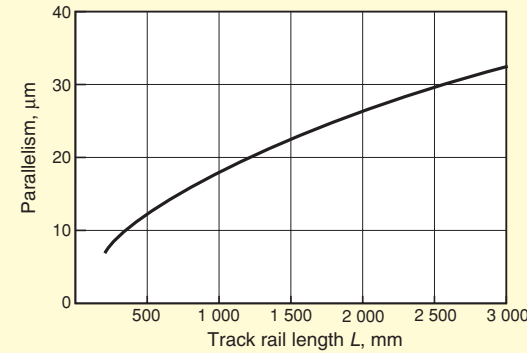

Fig. 5-2 Running parallelism of Linear Way Bearing Unit (Type 2)

Bearing Mounting

- Do not change the factory assembled combination of the slide units and track rail. Handle the linear way bearing units carefully to keep them out of oil stains and dust.
- Before installing a linear way bearing unit in a machine or equipment, remove burrs and indentations from the contact surface of both the machine and bearing unit. Also remove dust, contamination and oil stains. Clean the recesses of the mounting surface (Fig. 5-3).

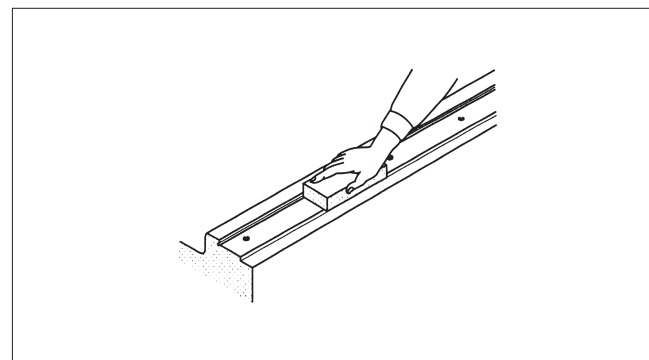

Fig. 5-3 Cleaning of the mounting surface

- After positioning the mounting reference plane of the track rail correctly to the mounting reference plane of the bed, temporarily fasten the track to the bed (Fig. 5-4). Then bring the two planes into close contact, using a small vice or other suitable tool. Tighten the bolts one by one to securely fasten the drive side track rail to the bed (Fig. 5-5). The driven side track rail of the Linear Way Bearing Unit should be kept temporarily fastened.

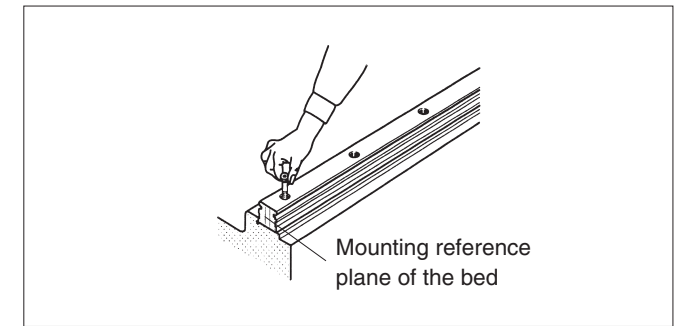

Fig. 5-4 Temporary fastening of the track rail

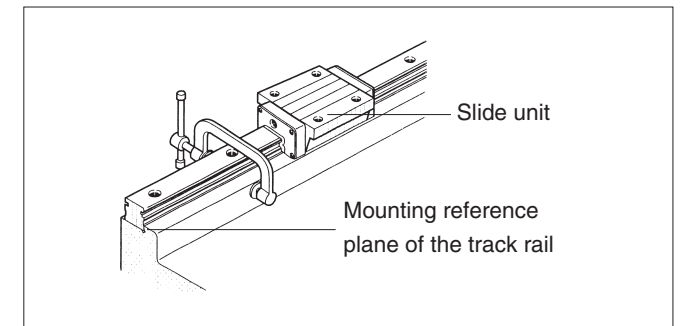

Fig. 5-5 Fastening of the drive side track rail

- After positioning the slide units of the linear way bearing unit to the table, place the table carefully on the slide units and then temporarily fasten them together. Then align the mounting reference plane of the drive side slide units correctly with that of the table and fasten them together. With one of the driven side slide units positioned and fixed with respect to the moving direction, leave the other slide unit loosely tightened.

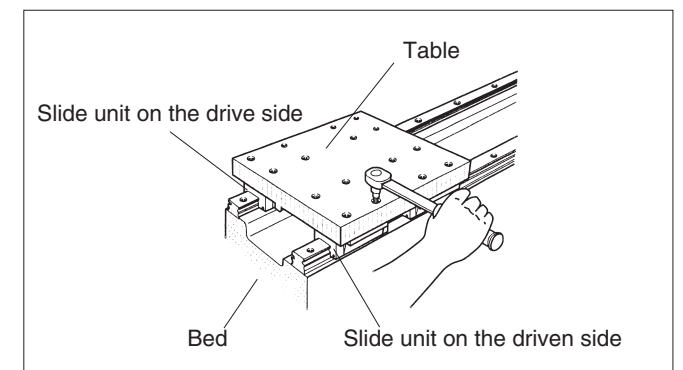

Fig. 5-6 Fastening of the slide unit

- Before securely fastening the temporarily fastened track rail on the driven side, move the table and check that the motion is smooth. Tighten the fastening bolt that has just been passed over by the slide unit, thus fastening the track rail to the bed in a step-by-step manner (Fig. 5-7). Securely fasten the slide unit to the table, which has been kept temporarily fastened.

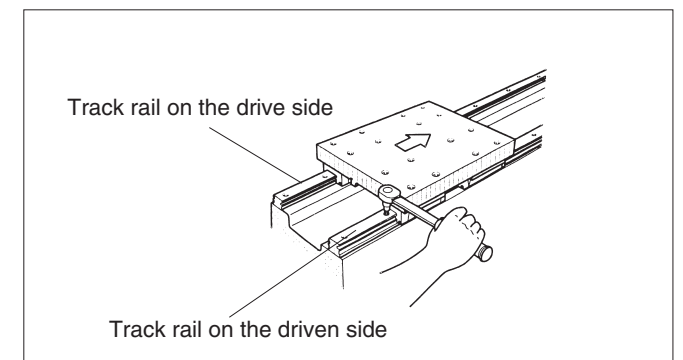
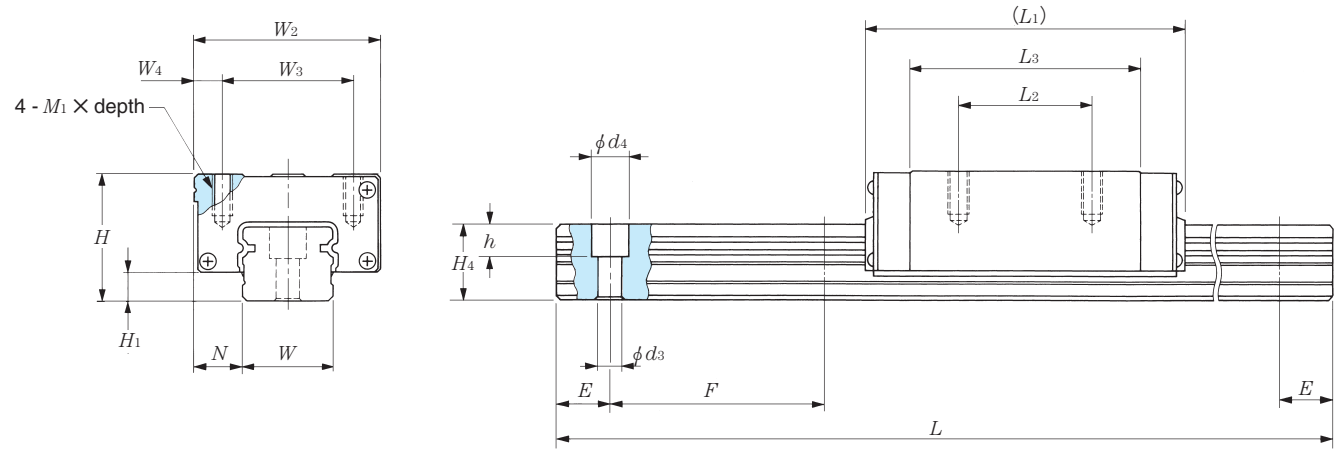

Fig. 5-7 Fastening of the driven side track rail

Dimensions Table

LWHS series



LWES series

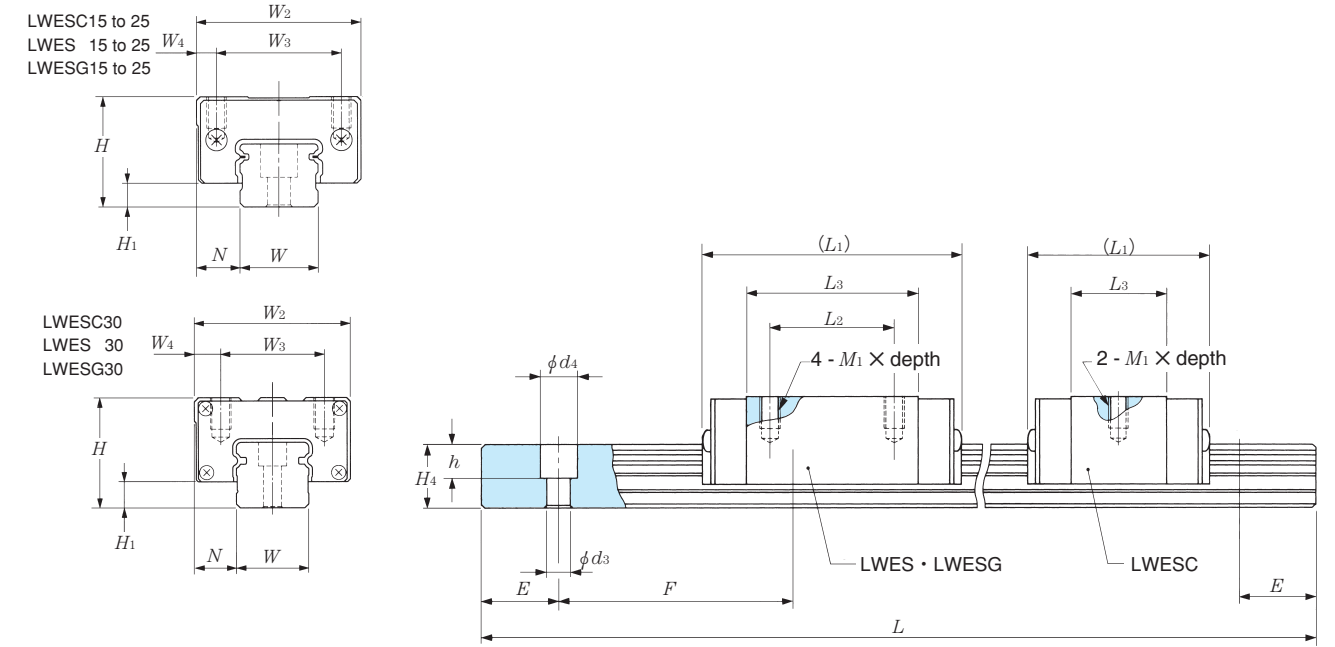

Basic No.	Mass (refer.)		Dimensions of assembly mm			Rail width mm	Dimensions of slide unit mm							Dimensions of track rail mm						Track rail fastening bolt mm (nominal) x l	Max. track rail length L mm	Basic load rating		Static bending moment rating ¹⁾			
	Slide unit kg	Track rail kg / m	H	H ₁	N		W	W ₂	W ₃	W ₄	L ₁	L ₂	L ₃	M ₁ x depth	H ₄	d ₃	d ₄	h	E			F	C N	C ₀ N	T ₀ N·m	T _x N·m	T _y N·m
LWHS 15	0.18	1.47	24	6	9.5	15	34	26	4	66	26	44.6	M4x8	15	4.5	8	6	30	60	M4x16	600	9 350	13 900	116	99.2 577	99.2 577	
LWHS 20	0.36	2.56	30	7.5	12	20	44	32	6	83	36	57.2	M5x10	18	6	9.5	8.5	30	60	M5x18	600	14 500	21 900	241	202 1 130	202 1 130	
LWHS 25	0.55	3.50	36	9	12.5	23	48	35	6.5	95	35	64.7	M6x12	22	7	11	9	30	60	M6x22	600	20 100	29 800	376	320 1 750	320 1 750	
LWHS 30	1.00	4.82	42	10	16	28	60	40	10	113	40	80.6	M8x16	25	9	14	12	40	80	M8x28	600	28 100	42 200	646	556 2 930	556 2 930	

Note 1) The illustrations at right show the directions of the static bending moment ratings T_0 , T_x , and T_y . Each of the upper values in the T_x and T_y columns shows the bending moment for a single slide unit, and the lower value shows the bending moment for two slide units kept in close contact.

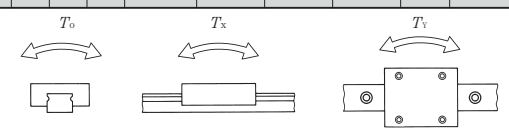

Basic No.	Mass (refer.)		Dimensions of assembly mm			Rail width mm	Dimensions of slide unit mm							Dimensions of track rail mm						Track rail fastening bolt mm (nominal) x l	Max. track rail length L mm	Basic load rating		Static bending moment rating ¹⁾						
	Slide unit kg	Track rail kg / m	H	H ₁	N		W	W ₂	W ₃	W ₄	L ₁	L ₂	L ₃	M ₁ x depth	H ₄	d ₃	d ₄	h	E			F	C N	C ₀ N	T ₀ N·m	T _x N·m	T _y N·m			
LWESC15	0.09																								600	4 330	5 680	45.4	22.1 155	22.1 155
LWES 15	0.14	1.57	24	5.8	9.5	15	34	26	4				M4x7	14.5	3.6	6.5	4.5	20	60	M3x16	600	6 200	9 740	77.9	59.8 346	59.8 346				
LWESG15	0.18																								600	7 520	13 000	104	103 553	103 553
LWESC20	0.15																								600	6 250	7 610	81.8	32.6 244	32.6 244
LWES 20	0.25	2.28	28	6	11	20	42	32	5				M5x8	16	6	9.5	8.5	20	60	M5x16	600	9 360	13 900	150	99.2 582	99.2 582				
LWESG20	0.33																								600	11 500	19 000	204	178 952	178 952
LWESC25	0.26																								600	10 100	12 800	159	74.5 498	74.5 498
LWES 25	0.42	3.09	33	7	12.5	23	48	35	6.5				M6x9	19	7	11	9	20	60	M6x20	600	14 500	21 900	272	202 1 130	202 1 130				
LWESG25	0.55																								600	17 600	29 200	362	348 1 810	348 1 810
LWESC30	0.46																								600	16 800	19 500	298	134 887	134 887
LWES 30	0.78	5.09	42	10	16	28	60	40	10				M8x12	25	7	11	9	20	80	M6x25	600	23 600	32 500	497	340 1 990	340 1 990				
LWESG30	1.13																								600	30 900	48 700	745	730 3 810	730 3 810

Note 1) The illustrations at right show the directions of the static bending moment ratings T_0 , T_x , and T_y . Each of the upper values in the T_x and T_y columns shows the bending moment for a single slide unit, and the lower value shows the bending moment for two slide units kept in close contact.

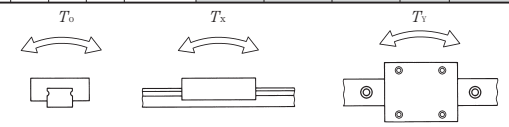

LWL series

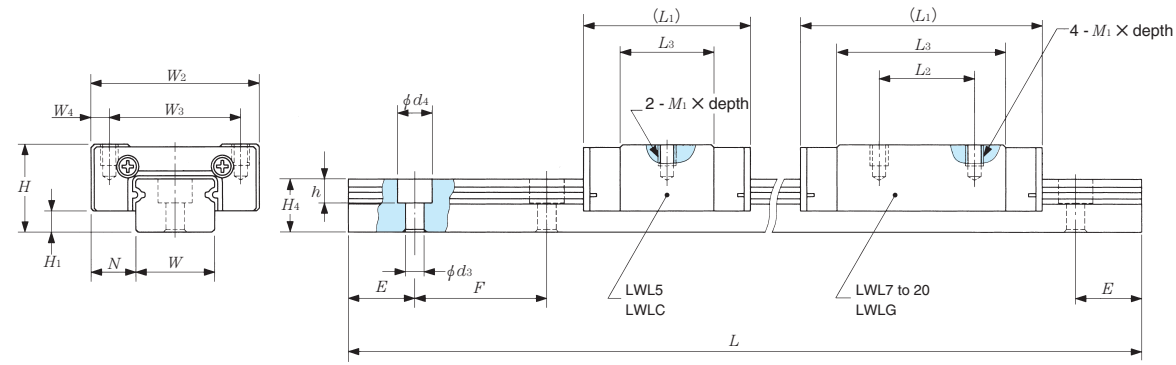

Basic No.	Mass (refer.)		Dimensions of assembly mm			Rail width mm	Dimensions of slide unit mm						Dimensions of track rail mm						Track rail fastening bolt mm (nominal) x l	Max. track rail length L mm	Basic load rating		Static bending moment rating ¹⁾				
	Slide unit g	Track rail g/100mm	H	H1	N		W	W2	W3	W4	L1	L2	L3	M1 x depth	H4	d3	d4	h			E	F	C N	C0 N	T0 N·m	Tx N·m	Ty N·m
LWLC 5	3.4	12	6	1	3.5	5	12	8	2	16	-	9.6	M2x1.5	3.7	2.4	3.6	0.8	7.5	15	Cross recessed round head screw M2x6	210	514	872	2.3	1.4	1.2	
LWL 5	4.4	12	6	1	3.5	5	12	8	2	19	-	12.6	M2x1.5	3.7	2.4	3.6	0.8	7.5	15	Hexagon socket head cap bolt M2x6	300	612	1130	3.0	2.4	2.0	
LWLC 7	7.1	22	8	1.5	5	7	17	12	2.5	19	-	9.6	M2x2.5	5	2.4	4.2	2.3	7.5	15	Hexagon socket head cap bolt M2x6	300	856	1180	4.3	1.9	1.6	
LWL 7	10	22	8	1.5	5	7	17	12	2.5	23.5	8	14.3	M2x2.5	5	2.4	4.2	2.3	7.5	15	Hexagon socket head cap bolt M2x6	300	1200	1960	7.2	4.9	4.1	
LWLG 7	14	22	8	1.5	5	7	17	12	2.5	31	12	21.6	M2x2.5	5	2.4	4.2	2.3	7.5	15	Hexagon socket head cap bolt M2x6	300	1510	2750	10.0	9.1	7.7	
LWLC 9	11	35	10	2	5.5	9	20	15	2.5	21.5	-	11.9	M3x3	6	3.5	6	3.5	10	20	Hexagon socket head cap bolt M3x8	600	1070	1540	7.2	3.0	2.5	
LWL 9	19	35	10	2	5.5	9	20	15	2.5	30	10	20.8	M3x3	6	3.5	6	3.5	10	20	Hexagon socket head cap bolt M3x8	600	1610	2860	13.3	9.4	7.9	
LWLG 9	28	35	10	2	5.5	9	20	15	2.5	40.5	15	30.9	M3x3	6	3.5	6	3.5	10	20	Hexagon socket head cap bolt M3x8	600	2080	4180	19.4	19.4	16.3	
LWLC12	22	65	13	3	7.5	12	27	20	3.5	25	-	13	M3x3.5	8	3.5	6.5	4.5	12.5	25	Hexagon socket head cap bolt M3x8	600	2000	2470	15.3	5.5	4.7	
LWL 12	35	65	13	3	7.5	12	27	20	3.5	34	15	21.6	M3x3.5	8	3.5	6.5	4.5	12.5	25	Hexagon socket head cap bolt M3x8	600	2960	4450	27.6	16.0	13.4	
LWLG12	51	65	13	3	7.5	12	27	20	3.5	44	20	32	M3x3.5	8	3.5	6.5	4.5	12.5	25	Hexagon socket head cap bolt M3x8	600	3780	6430	39.9	31.8	26.7	
LWLC15	42	107	16	4	8.5	15	32	25	3.5	32	-	17.7	M3x4	10	3.5	6.5	4.5	20	40	Hexagon socket head cap bolt M3x10	600	3120	4040	31.1	12.1	10.2	
LWL 15	64	107	16	4	8.5	15	32	25	3.5	42	20	27.8	M3x4	10	3.5	6.5	4.5	20	40	Hexagon socket head cap bolt M3x10	600	4390	6730	51.8	30.8	25.9	
LWLG15	95	107	16	4	8.5	15	32	25	3.5	57	25	42.7	M3x4	10	3.5	6.5	4.5	20	40	Hexagon socket head cap bolt M3x10	600	5750	10100	77.7	66.2	55.6	
LWLC20	89	156	20	5	10	20	40	30	5	38	-	22.3	M4x6	11	6	9.5	5.5	30	60	Hexagon socket head cap bolt M5x14	600	4070	5490	56.0	20.2	16.9	
LWL 20	133	156	20	5	10	20	40	30	5	50	25	34.6	M4x6	11	6	9.5	5.5	30	60	Hexagon socket head cap bolt M5x14	600	5830	9420	96.1	54.6	45.8	
LWLG20	196	156	20	5	10	20	40	30	5	68	30	52.3	M4x6	11	6	9.5	5.5	30	60	Hexagon socket head cap bolt M5x14	600	7350	13300	136	106	88.9	

Note 1) The illustrations at right show the directions of the static bending moment ratings T_0 , T_x , and T_y . Each of the upper values in the T_x and T_y columns shows the bending moment for a single slide unit, and the lower value shows the bending moment for two slide units kept in close contact.

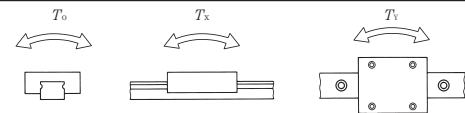

LWLF series

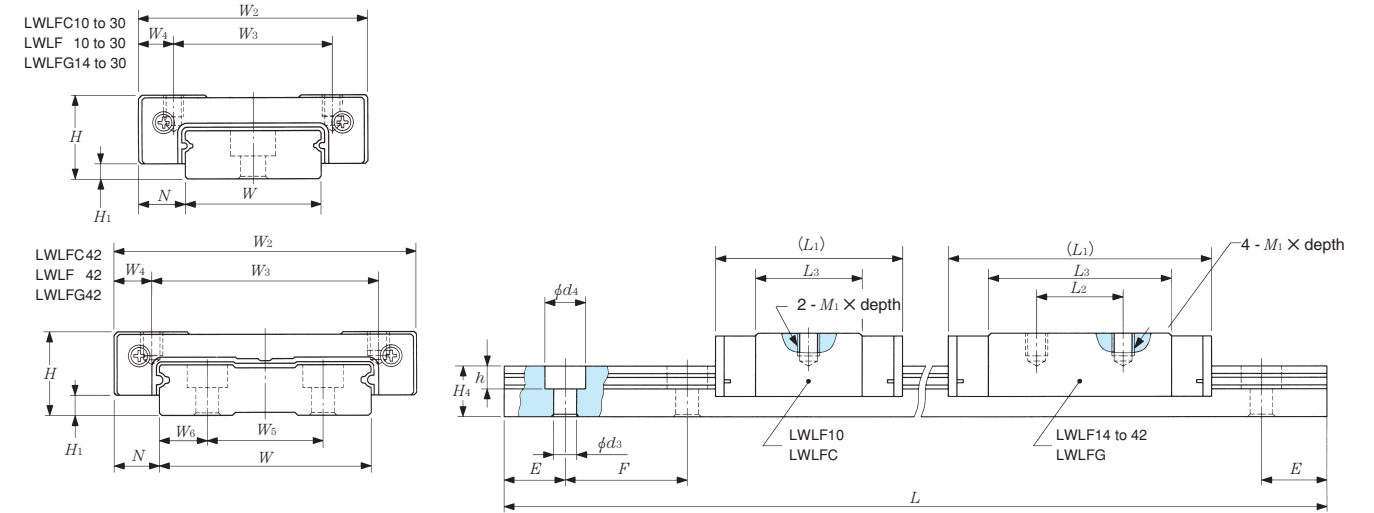

Basic No.	Mass (refer.)		Dimensions of assembly mm			Rail width mm	Dimensions of slide unit mm						Dimensions of track rail mm						Track rail fastening bolt mm (nominal) x l	Max. track rail length L mm	Basic load rating		Static bending moment rating ¹⁾						
	Slide unit g	Track rail g/100mm	H	H1	N		W	W2	W3	W4	L1	L2	L3	M1 x depth	H4	W5	W6	d3			d4	h	E	F	C N	C0 N	T0 N·m	Tx N·m	Ty N·m
LWLC10	5.9	28	6.5	1.5	3.5	10	17	13	2	20.5	-	13.6	M2.5x1.5	4	-	-	2.9	4.8	1.6	10	20	Cross recessed round head screw M2.5x7	300	643	1220	6.3	2.7	2.3	
LWLF 10	7.5	28	6.5	1.5	3.5	10	17	13	2	24.5	-	17.6	M2.5x1.5	4	-	-	2.9	4.8	1.6	10	20	Hexagon socket head cap bolt M3x8	300	760	1570	8.1	4.4	3.7	
LWLC14	13	54	9	2	5.5	14	25	19	3	22.5	-	13	M3x3	5.5	-	-	3.5	6	3.2	15	30	Hexagon socket head cap bolt M3x8	300	1120	1770	12.6	4.0	3.3	
LWLF 14	21	54	9	2	5.5	14	25	19	3	31.5	10	22	M3x3	5.5	-	-	3.5	6	3.2	15	30	Hexagon socket head cap bolt M3x8	300	1580	2940	21.0	10.4	8.7	
LWLF14	21	54	9	2	5.5	14	25	19	3	42	19	32.5	M3x3	5.5	-	-	3.5	6	3.2	15	30	Hexagon socket head cap bolt M3x8	300	2040	4320	30.9	21.8	18.3	
LWLF18	44	90	12	3	6	18	30	21	4.5	26.5	-	16.6	M3x3	7	-	-	3.5	6.5	4.5	15	30	Hexagon socket head cap bolt M3x8	600	1360	2200	20.1	5.8	4.8	
LWLF18	44	90	12	3	6	18	30	21	4.5	39	12	28.6	M3x3	7	-	-	3.5	6.5	4.5	15	30	Hexagon socket head cap bolt M3x8	600	2010	3960	36.2	17.5	14.7	
LWLF18	61	90	12	3	6	18	30	23	3.5	50.5	24	40.4	M3x3	7	-	-	3.5	6.5	4.5	15	30	Hexagon socket head cap bolt M3x8	600	2500	5500	50.3	33.0	27.7	
LWLF24	76	139	14	3	8	24	40	28	6	30.5	-	17.7	M3x3.5	8	-	-	4.5	8	4.5	20	40	Hexagon socket head cap bolt M4x10	600	2500	3460	42.2	10.1	8.5	
LWLF24	76	139	14	3	8	24	40	28	6	44	15	31	M3x3.5	8	-	-	4.5	8	4.5	20	40	Hexagon socket head cap bolt M4x10	600	3780	6430	78.4	31.8	26.7	
LWLF24	111	139	14	3	8	24	40	28	6	59	28	46.3	M3x3.5	8	-	-	4.5	8	4.5	20	40	Hexagon socket head cap bolt M4x10	600	4870	9400	115	65.6	55.0	
LWLF30	112	198	15	3	10	30	50	35	7.5	35.5	-	20.5	M4x4.5	9	-	-	4.5	8	4.5	20	40	Hexagon socket head cap bolt M4x12	600	3460	4710	71.6	16.0	13.4	
LWLF30	112	198	15	3	10	30	50	35	7.5	50	18	34.8	M4x4.5	9	-	-	4.5	8	4.5	20	40	Hexagon socket head cap bolt M4x12	600	5230	8750	133	50.5	42.4	
LWLF30	170	198	15	3	10	30	50	35	7.5	68.5	35	53.8	M4x4.5	9	-	-	4.5	8	4.5	20	40	Hexagon socket head cap bolt M4x12	600	6730	12800	194	104	87.4	
LWLF42	140	294	16	4	9	42	60	45	7.5	41.5	-	25.3	M4x4.5	10	23	9.5	4.5	8	4.5	20	40	Hexagon socket head cap bolt M4x12	600	4450	6280	133	25.7	21.6	
LWLF42	140	294	16	4	9	42	60	45	7.5	55	20	39	M4x4.5	10	23	9.5	4.5	8	4.5	20	40	Hexagon socket head cap bolt M4x12	600	6150	10200	216	63.6	53.3	
LWLF42	204	294	16	4	9	42	60	45	7.5	74.5	35	58.3	M4x4.5	10	23	9.5	4.5	8	4.5	20	40	Hexagon socket head cap bolt M4x12	600	7910	14900	316	131	110	

Note 1) The illustrations at right show the directions of the static bending moment ratings T_0 , T_x , and T_y . Each of the upper values in the T_x and T_y columns shows the bending moment for a single slide unit, and the lower value shows the bending moment for two slide units kept in close contact.

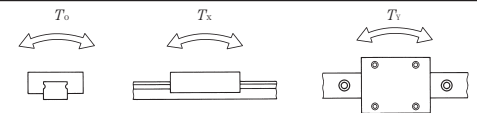

5-3 Cross Roller Way Bearing Units for Use in Extreme Special Environments

The Cross Roller Way Bearing Unit is a linear motion bearing unit consisting of two raceway bases. Each base has one longitudinal plane cut into a V shape, which serves as the rolling surface. Two bases are in contact on each of the other's V-cut surface, and cylindrical rollers with a retainer are placed between the surfaces. Any pair of adjacent cylindrical rollers is directed at right angles to each other, thus enabling smooth and extremely accurate linear motion.

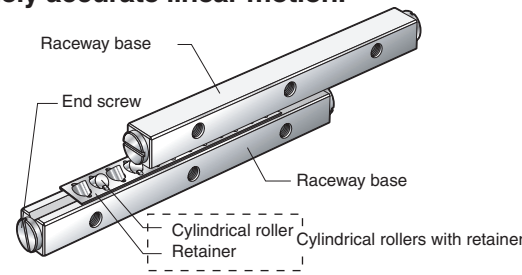

Bearing Types

	DL Cross Roller Way Bearing Unit	Clean Pro Cross Roller Way Bearing Unit	MO Cross Roller Way Bearing Unit
Material	Raceway base	Martensitic stainless steel	
	Cylindrical rollers		
	Retainer		
	End screw	Austenitic stainless steel	
Lubricant	KDL grease	Clean pro coating over the entire surface of all components	Molybdenum disulfide coating on the raceway bases

Applicable Environments

	DL Cross Roller Way Bearing Unit	Clean Pro Cross Roller Way Bearing Unit	MO Cross Roller Way Bearing Unit
Cleanliness	Class 100	Class 10	-
Temperature °C	- 30 to 200	- 100 to 200	- 100 to 300
Ambient pressure Pa	Normal to 10 ⁻⁵	Normal to 10 ⁻⁵	Normal to 10 ⁻⁵

Bearing Numbering System

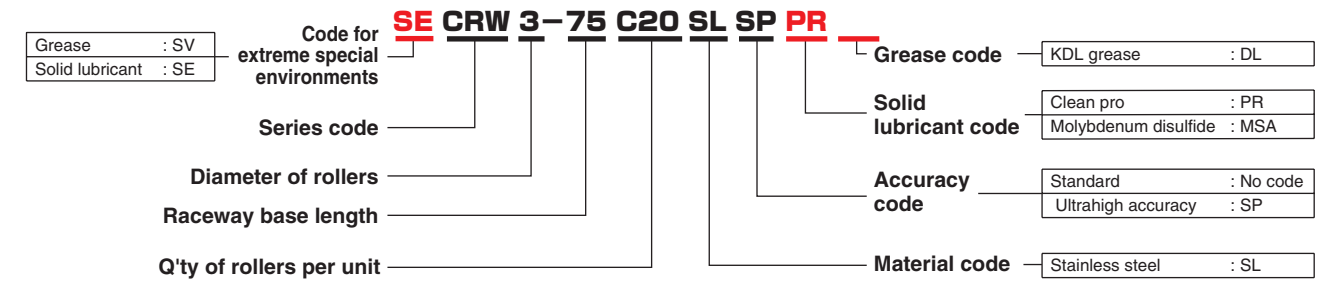

Note) This bearing number represents four raceway bases and two sets cylindrical rollers with retainer.

Tolerance (before surface treatment)

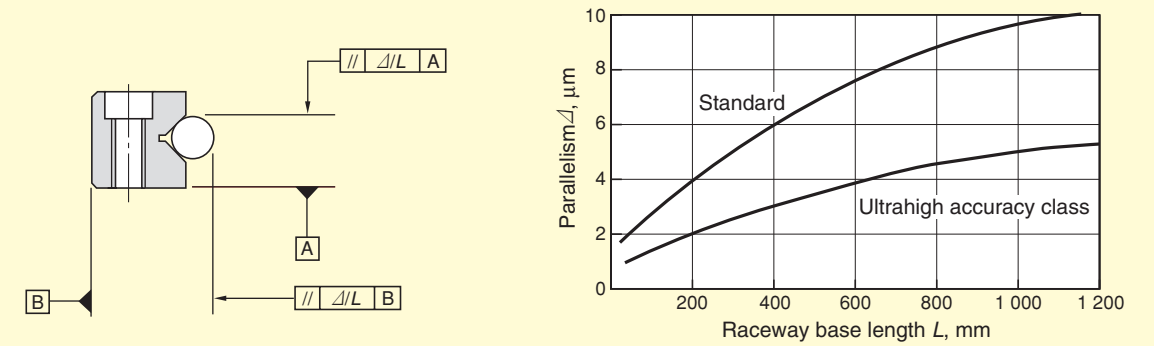

Bearing Mounting

Fig. 5-8 shows a typical mounting construction of the Cross Roller Way Bearing Unit. Mounting procedures are described on the following page.

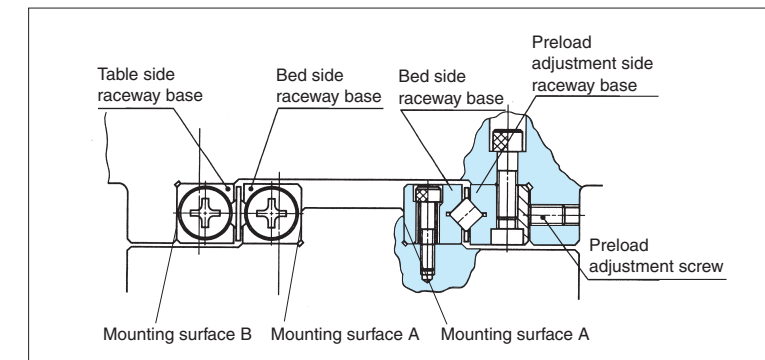

Fig. 5-8 Typical mounting of Cross Roller Way Bearing Unit

- 1) One package includes an entire set of the components of a cross roller way bearing unit (four raceway bases and two sets of cylindrical rollers with retainer). Take care not to mix the components of a set not compatible with those of another set. Treat cross roller way bearing units with extra care to keep them free from oil stains or contamination.
- 2) Remove burrs, indentations and other irregularities from the machine surface on which the cross roller way bearing unit is to be mounted. Also clean off dust, contamination and oil stains. Clean the recesses of the mounting surface as well.
- 3) Place the bed side raceway base and table side raceway base correctly on the each mounting surface, and fasten the bases temporarily by tightening the screws evenly. While keeping the bed side raceway base in close contact with surface A and the table side raceway base with surface B, tighten the screws permanently to a specified torque (Fig. 5-9). Table 5-1 shows the tightening torque for individual regular screw sizes.

Table 5-1 Screw tightening torque

Nominal screw size	Tightening torque N · m
M2×0.4	0.23
M3×0.5	1.4
M4×0.7	3.2
M5×0.8	6.3
M6×1	10.7

Remark) When screws of different sizes are used for on the table side and bed side, tighten them by applying the torque for the smaller screws.

- 4) Retract the preload adjustment screw in advance. Place the preload adjustment side raceway base into close contact with the mounting surface, and tighten the screws temporarily by applying light, even torque.
- 5) To assemble the table and bed, insert cylindrical rollers with retainer carefully into the space between the table side raceway base and bed side raceway base such that the rollers will be located at the center of the raceway base length. Take care not to deform the cage. Fasten the end screws and end plates of the raceway bases, press the entire table toward the preload adjustment screw side, and tighten the screw for temporary adjustment until the clearance of the raceways is almost entirely eliminated. Slowly move the table for one entire stroke and adjust the position of the cylindrical rollers with retainer to the center.

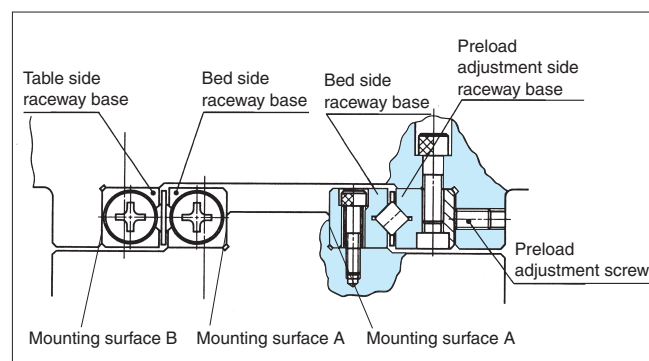

(Fig. 5-8 Typical mounting of Cross Roller Way Bearing Unit)

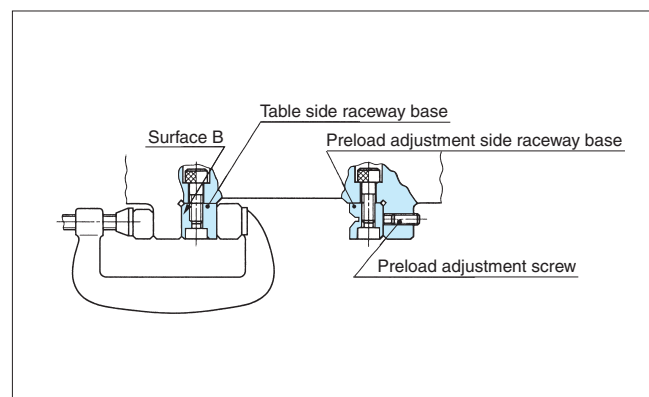

Fig. 5-9 Mounting of table side raceway base

- 6) Adjust the preload with the preload adjustment side raceway base fastened temporarily. Firstly adjust the preload adjustment screw at the center of the raceway base length, and adjust the preload adjustment screws on the lengths to both ends alternately. Adjust the clearance on the side face of the table, and tighten the preload adjustment screws one by one until the dial gauge indication becomes stable (Fig. 5-10). When the indication is stable, determine and record the tightening torque of the preload adjustment screws. To adjust the preload adjustment screws near both ends, stroke the table slowly to check that cylindrical rollers are located at the preload adjustment screw. After these adjustments, the clearance will be entirely or almost eliminated. However, at this point the preload is not yet even. By repeating the same procedure, re-adjust all the preload adjustment screws by applying the torque recorded.

- 7) When permanently fastening the preload adjustment side raceway base, make sure the screws have already been lightly tightened to even torque. In the same manner as the preload adjustment screws were tightened, firstly adjust the preload adjustment screw at the center of the raceway base length, and adjust the preload adjustment screws on the lengths to both ends alternately by applying torque close to the specified torque. To tighten the fastening screws near the ends, stroke the table slowly to check that the cylindrical rollers are located at the tightened screw position. In the end, tighten all screws evenly and permanently by applying specified torque. Move the table slowly through the entire stroke and check that it moves smoothly without producing noise. Check the table upper surface and side faces with a dial gauge to check running accuracy.

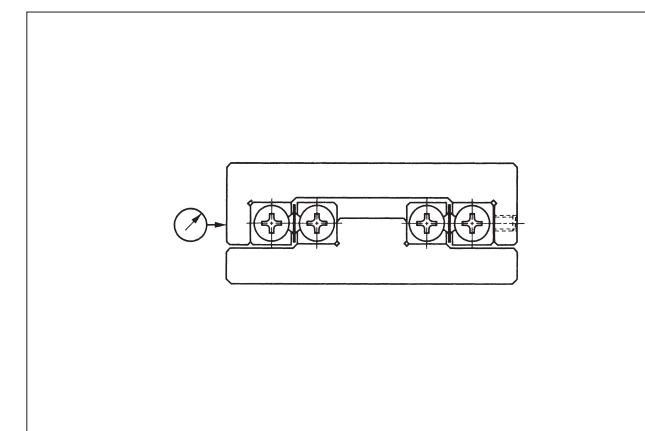

Fig. 5-10 Typical preload adjustment procedure

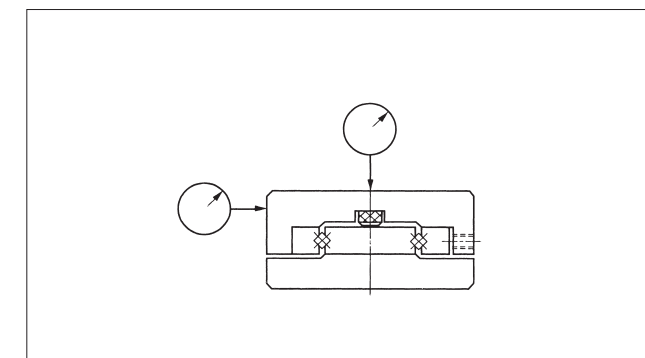
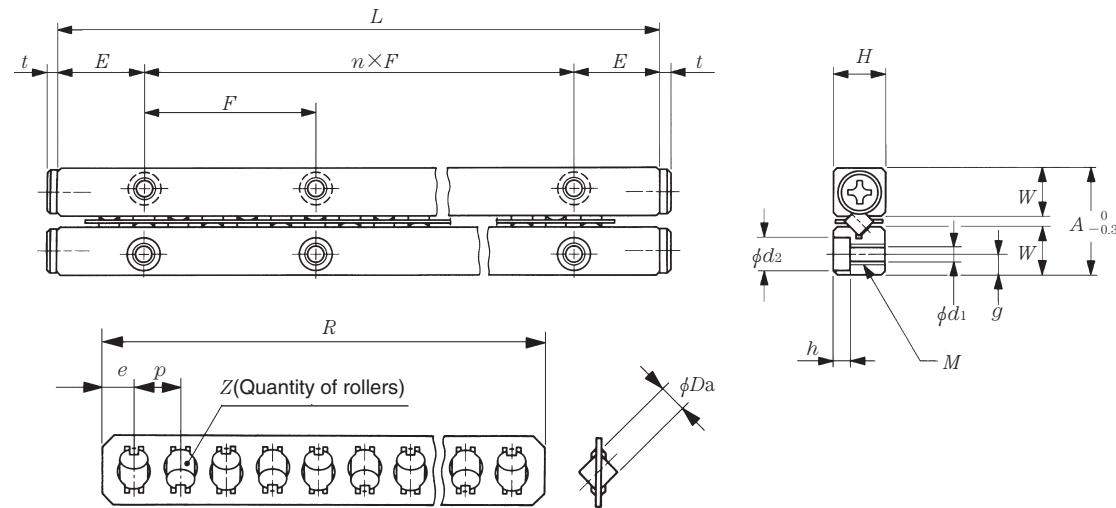

Fig. 5-11 Accuracy check after assembly

Dimensions Table

CRW series



Basic No.	Mass (refer.)		Boundary dimensions mm					Dimensions of cylindrical rollers with retainer mm				Mounting dimensions mm						Basic load rating		Allowable load $F_{L1}^{3)}$	
	Raceway base ¹⁾ kg / m	Cylindrical rollers with retainer ²⁾ g	A	H	L (n x F)	E	D _a	R	Z	p	e	W	g	M	d ₁	d ₂	h	t	C _U ³⁾ N		C _{0U} ³⁾ N
CRW1 - 20	0.12	0.38	8.5	4	20 (1x10)	5	1.5	16.5	5	3	2.25	3.9	1.8	M2	1.65	3	1.4	1.7	131	119	39.4
- 30					30 (2x10)			25.5	8												
- 40					40 (3x10)			31.5	10												
- 50					50 (4x10)			37.5	12												
- 60					60 (5x10)			43.5	14												
- 70					70 (6x10)			52.5	17												
- 80					80 (7x10)			61.5	20												
CRW2 - 30	0.24	0.98	12	6	30 (1x15)	7.5	2	29.6	7	4	2.8	5.5	2.5	M3	2.55	4.4	2	1.5	305	292	97.3
- 45					45 (2x15)			41.6	10												
- 60					60 (3x15)			53.6	13												
- 75					75 (4x15)			65.6	16												
- 90					90 (5x15)			77.6	19												
-105					105 (6x15)			89.6	22												
-120					120 (7x15)			101.6	25												
-135					135 (8x15)			113.6	28												
-150					150 (9x15)			125.6	31												
-165					165 (10x15)			137.6	34												
-180	180 (11x15)	149.6	37																		
CRW3 - 50	0.50	2.96	18	8	50 (1x25)	12.5	3	42	8	5	3.5	8.3	3.5	M4	3.3	6	3.1	2	664	606	202
- 75					75 (2x25)			62	12												
-100					100 (3x25)			82	16												
-125					125 (4x25)			102	20												
-150					150 (5x25)			122	24												
-175					175 (6x25)			142	28												
-200					200 (7x25)			162	32												
-225					225 (8x25)			182	36												
-250					250 (9x25)			202	40												
-275					275 (10x25)			222	44												
-300					300 (11x25)			242	48												

Notes 1) Mass per meter of raceway base length
 2) Mass of an assembly of a cage and ten cylindrical rollers
 3) Load per cylindrical roller

Basic No.	Mass (refer.)		Boundary dimensions mm					Dimensions of cylindrical rollers with retainer mm				Mounting dimensions mm						Basic load rating		Allowable load $F_{L1}^{3)}$	
	Raceway base ¹⁾ kg / m	Cylindrical rollers with retainer ²⁾ g	A	H	L (n x F)	E	D _a	R	Z	p	e	W	g	M	d ₁	d ₂	h	t	C _U ³⁾ N		C _{0U} ³⁾ N
CRW4 - 80	0.82	6.91	22	11	80 (1x40)	20	4	73	10	7	5	10	4.5	M5	4.3	7.5	4.1	2	1290	1170	389
-120					120 (2x40)			101	14												
-160					160 (3x40)			136	19												
-200					200 (4x40)			164	23												
-240					240 (5x40)			199	28												
-280					280 (6x40)			227	32												
-320					320 (7x40)			262	37												
-360					360 (8x40)			297	42												
-400					400 (9x40)			325	46												
-440					440 (10x40)			360	51												
-480	480 (11x40)	388	55																		
CRW6 -100	1.57	20.3	31	15	100 (1x50)	25	6	84	9	9	6	14	6	M6	5.3	9.5	5.2	3	2680	2290	764
-150					150 (2x50)			129	14												
-200					200 (3x50)			165	18												
-250					250 (4x50)			210	23												
-300					300 (5x50)			246	27												
-350					350 (6x50)			282	31												
-400					400 (7x50)			327	36												
-450					450 (8x50)			363	40												
-500					500 (9x50)			408	45												
-550					550 (10x50)			444	49												
-600	600 (11x50)	489	54																		

Notes 1) Mass per meter of raceway base length
 2) Mass of an assembly of a cage and ten cylindrical rollers
 3) Load per cylindrical roller

6 High Ability Angular Contact Ball Bearings

The High Ability Angular Contact Ball Bearings are optimized for the spindle of machine tools. They have superior high speed performance and rapid acceleration/deceleration, and are especially excellent at ultrahigh speeds under oil/air lubrication. They are superior in high speed performance to conventional products under grease lubrication as well.

For practical use of this type of bearings, refer to JTEKT Catalogue “Precision Ball and Roller Bearings for Machine Tools” (CAT. NO. B2005E) or “High Ability Angular Contact Ball Bearings for Machining Tools” (CAT. NO. B2006E) for High Ability Angular Contact Ball Bearings.







Types and Applications

The High Ability Angular Contact Ball Bearings are classified as shown in Table 1, according to bearing construction and rolling element material.

Select the optimal type best suited for your application needs.

Table 1 Classification of High Ability Angular Contact Ball Bearings

Type	Specifications			Application
	Bearing dimension series No.	Contact angle	Rolling element material	
Type R 	10 19	15° 20° 30°	Steel or ceramic	High speed, high rigidity type
Type C 	10 19	15° 20°	Ceramic	High speed, high load rating type
Type D 	10	20°	Ceramic	Ultrahigh speed, low noise type For oil/air lubrication
Type F 	10 19	20°	Ceramic	Ultrahigh speed type For oil/air lubrication

Features

- **20 to 30% reduction in temperature increase**
(compared with JTEKT's conventional products)

JTEKT has conducted various tests and analyses and developed elaborate machining techniques to improve the performance of bearings used with machining tool spindles. The result is a substantial reduction in frictional heat generated in bearings rotating at a high speed.

- **1.2- to 1.5- fold increases in speed limits**
(compared with JTEKT's conventional products)

Speed limits have been extended through re-designing for high-speed rotation and heat reduction. Use of ceramic balls as rolling elements enables additional high-speed rotation.

- **Improved high speed performance achieved by position preloading**

Low increases in temperature during operation ensure reduced changes in preload. Preload can be given by position preloading even at high speeds, which has been hitherto unavailable with conventional systems. The result is high-precision machining with stability.

- **Conventional bearings easily replaced**

Dimensions of High Ability bearings conform to ISO standards. Replacement of conventional bearings with High Ability bearings requires minimal geometry changes of the present spindle or housing.

Bearing Numbering System

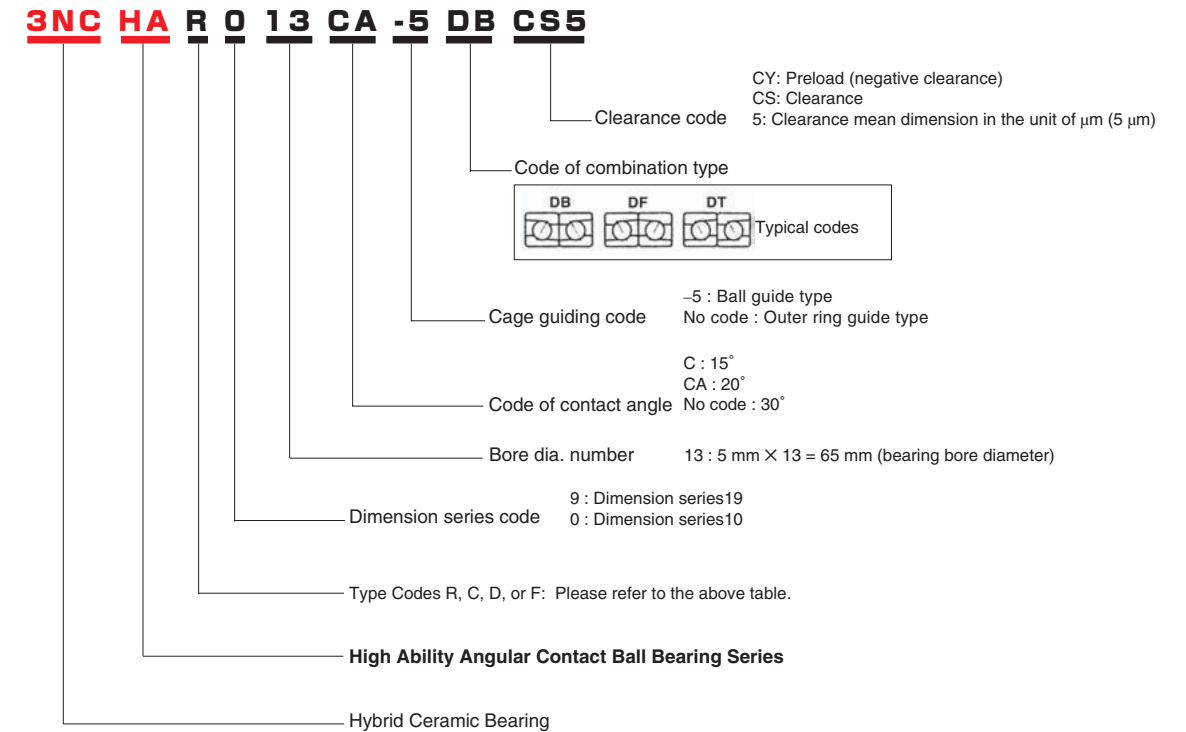

7 Ceramic Balls

JTEKT also supplies Ceramic Balls (silicon nitride), which have excellent resistance to wear and seizure, and are usable in corrosive environments and ultrahigh vacuums. Other major features of these balls are excellent heat resistance (up to 800°C), high rigidity, lightweight (40% compared to bearing steel), non-magnetic, and have insulating characteristics.

The Ceramic Balls are useful in many applications such as jigs, tools, gauges, solenoid valves, check valves, other valve varieties, high grade bicycle parts, automotive parts, and machine components.



Table of Dimensions and Masses

Nominal dimension mm	inch	Nominal outside diameter mm	Precision grade ¹⁾	Mass ²⁾ (per piece)
0.8		0.800 00		0.866 mg
1.0		1.000 00		1.691 mg
1.2		1.200 00		2.922 mg
2.0	1/16	1.587 50	3 and 5	6.766 mg
	3/32	2.381 25		13.530 mg
	7/64	2.778 12		22.836 mg
3.5	1/8	3.175 00	5	36.262 mg
	5/32	3.968 75		54.129 mg
	3/16	4.762 50		72.511 mg
	7/32	5.556 25		0.105 7 g
	15/64	5.953 12		0.182 7 g
5	1/4	6.350 00	5	0.290 1 g
	17/64	6.746 88		0.356 8 g
	9/32	7.143 75		0.433 0 g
	5/16	7.937 50		0.519 4 g
	11/32	8.731 25		0.616 6 g
	3/8	9.525 00		0.845 8 g
	13/32	10.318 75		1.125 7 g
60	1 1/4	31.750 00	60	1.461 5 g
	1 5/16	33.337 50		1.858 2 g
	1 1/2	38.100 00		54.1 g
				62.7 g
				93.5 g

Notes 1) For the grades, those specified in JIS B 1501 shall apply.
2) The masses are calculated on the basis of 3.23 g/cm³ in density.

Numbering System

5/32 G5 NCR

Material code: silicon nitride ceramic
Precision grade code
Nominal dimension

Performance

High Ability Bearings demonstrate their utmost performance when two or more units are used together and a preload is provided by the position preloading method. The following are the performance of these bearings preloaded by the position preloading method.

High speed performance of Type R and Type C High Ability Bearings

Fig. 6-1 shows the relationship between rotational speed and bearing temperature rises of High Ability Bearings, in comparison with conventional high precision bearings.

In either grease lubrication or oil/air lubrication, the High Ability Bearings are superior to conventional bearings, with lower temperature rise and higher rotational speed limit.

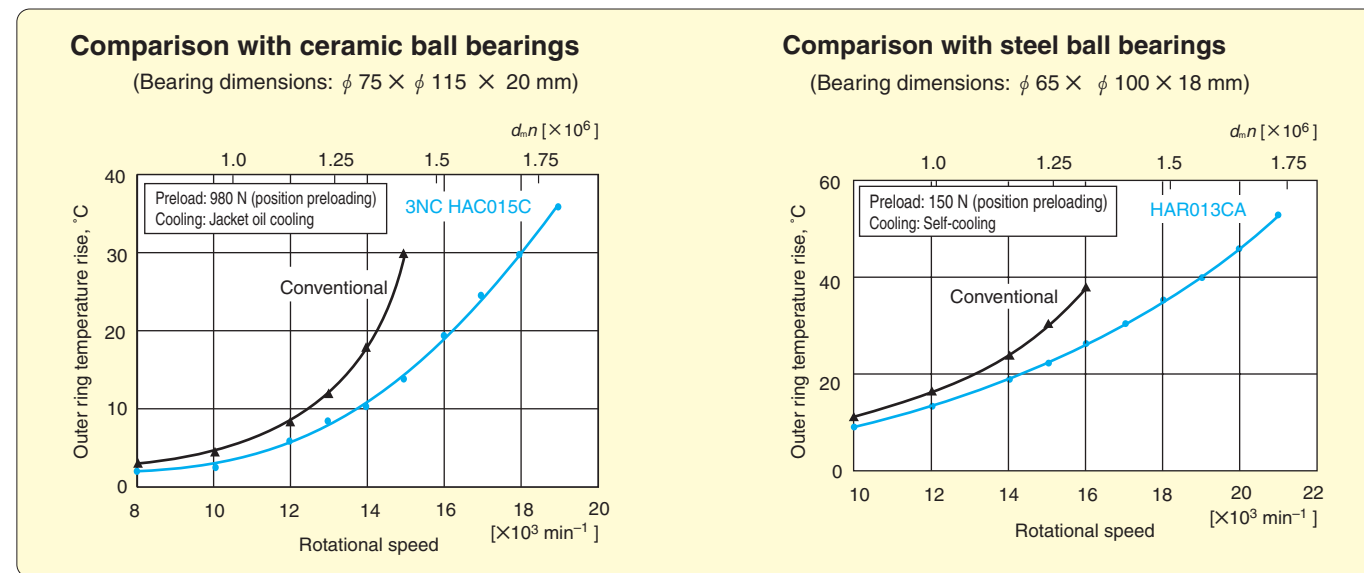

Fig. 6-1 Comparison in bearing temperature rises under oil air lubrication

By using High Ability Bearings, it is possible to switch spindle lubrication from oil/air to grease. The Type R High Ability Bearings having ceramic balls exhibit better high speed performance under grease lubrication than oil/air lubricated conventional bearings.

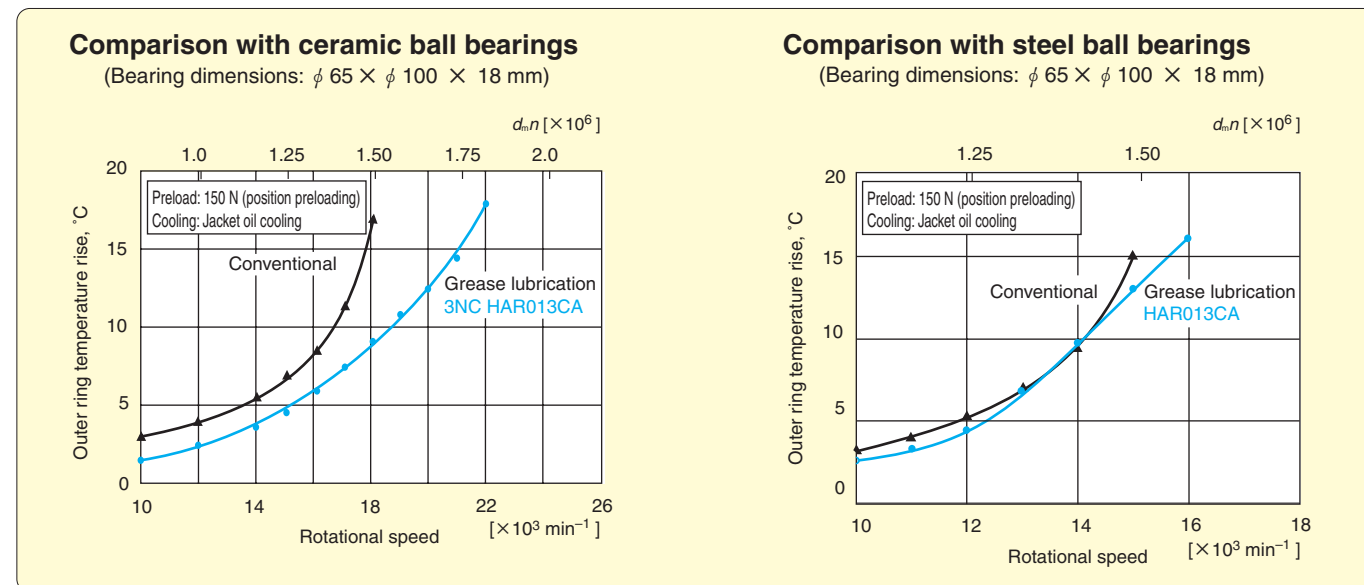

Fig. 6-2 Comparison in high speed performance under grease lubrication

8 Tolerance and Internal Clearance of Ceramic Bearings and EXSEV Bearings

8-1 Tolerance of Radial Ball Bearings

Table 8-1(1) Inner ring (bore diameter)

Unit: μm

Nominal bore diameter d mm	Single plane mean bore diameter deviation Δ_{dmp}								Single radial plane bore diameter variation V_{dsp}						Mean bore diameter variation V_{dmp}			
	class 0		class 6		class 5		Diameter series 7, 8, 9		Diameter series 0, 1		Diameter series 2, 3, 4		class 0		class 6		class 5	
	upper	lower	upper	lower	upper	lower	max.	max.	max.	max.	max.	max.	max.	max.	max.	max.		
0.6 ¹⁾ 2.5	0	-8	0	-7	0	-5	10	9	5	8	7	4	6	5	4	6	5	3
2.5 10	0	-8	0	-7	0	-5	10	9	5	8	7	4	6	5	4	6	5	3
10 18	0	-8	0	-7	0	-5	10	9	5	8	7	4	6	5	4	6	5	3
18 30	0	-10	0	-8	0	-6	13	10	6	10	8	5	8	6	5	8	6	3
30 50	0	-12	0	-10	0	-8	15	13	8	12	10	6	9	8	6	9	8	4

Note 1) Dimension 0.6 mm is included in this category.

Table 8-1(2) Inner ring (running tolerance and width)

Unit: μm

Nominal bore diameter d mm	Radial runout of assembled bearing inner ring K_{ia}			S_{ia}	$S_{ia}^{2)}$	Single inner ring width deviation Δ_{Bs}				Single inner ring width deviation $\Delta_{Bs}^{3)}$				Inner ring width variation V_{Bs}				
	class 0		class 6	class 5	class 5	class 5	class 0		class 6		class 5		class 0		class 6		class 5	
	over	up to	max.	max.	max.	upper	lower	upper	lower	upper	lower	upper	lower	upper	lower	upper	lower	max.
0.6 ¹⁾ 2.5	10	5	4	7	7	0	-40	0	-40	-	-	-	-	0	-250	12	12	5
2.5 10	10	6	4	7	7	0	-120	0	-120	0	-40	0	-250	0	-250	15	15	5
10 18	10	7	4	7	7	0	-120	0	-120	0	-80	0	-250	0	-250	20	20	5
18 30	13	8	4	8	8	0	-120	0	-120	0	-120	0	-250	0	-250	20	20	5
30 50	15	10	5	8	8	0	-120	0	-120	0	-120	0	-250	0	-250	20	20	5

S_{ia} : perpendicularity of inner ring face with respect to the bore $S_{ia}^{2)}$: axial runout of assembled bearing inner ring

Notes 1) Dimension 0.6 mm is included in this category.

2) Applicable to deep groove ball bearings and angular contact ball bearings.

3) Applicable to bearing rings made for matched bearings.

Table 8-2(1) Outer ring (outside diameter)

Unit: μm

Nominal outside diameter D mm	Single plane mean outside diameter deviation Δ_{Dmp}						Single plane outside diameter variation V_{Dsp}						Mean outside diameter variation V_{Dmp}							
	class 0		class 6		class 5		Diameter series 7, 8, 9		Diameter series 0, 1		Diameter series 2, 3, 4		Shielded/sealed type Diameter series 2, 3, 4		class 0		class 6		class 5	
	upper	lower	upper	lower	upper	lower	max.	max.	max.	max.	max.	max.	max.	max.	max.	max.	max.			
2.5 ¹⁾ 6	0	-8	0	-7	0	-5	10	9	5	8	7	4	6	5	4	10	9	6	5	3
6 18	0	-8	0	-7	0	-5	10	9	5	8	7	4	6	5	4	10	9	6	5	3
18 30	0	-9	0	-8	0	-6	12	10	6	9	8	5	7	6	5	12	10	7	6	3
30 50	0	-11	0	-9	0	-7	14	11	7	11	9	5	8	7	5	16	13	8	7	4
50 80	0	-13	0	-11	0	-9	16	14	9	13	11	7	10	8	7	20	16	10	8	5

Notes 1) Dimension 2.5 mm is included in this category.

2) Applicable when no snap ring is fitted.

Table 8-2(2) Outer ring (running tolerance and width)

Unit: μm

Nominal outside diameter D mm	Radial runout of assembled bearing outer ring K_{ea}			S_D	$S_{ea}^{2)}$	Deviation of a single outer ring width Δ_{Cs}		Ring width variation V_{Cs}		
	class 0		class 5	class 5	class 5	classes 0, 6 & 5		classes 0 & 6		class 5
	over	up to	max.	max.	max.	upper	lower	max.	max.	
2.5 ¹⁾ 6	15	8	5	8	8					5
6 18	15	8	5	8	8					5
18 30	15	9	6	8	8					5
30 50	20	10	7	8	8					5
50 80	25	13	8	8	10					6

S_D : perpendicularity of outer ring outside surface with respect to the face $S_{ea}^{2)}$: axial runout of assembled bearing outer ring

Notes 1) Dimension 2.5 mm is included in this category.

2) Applicable to deep groove ball bearings and angular contact ball bearings.

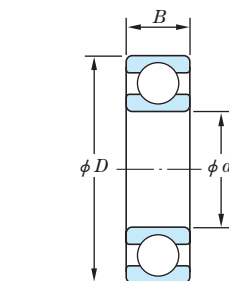

d : Nominal bore diameter
 D : Nominal outside diameter
 B : Nominal assembled bearing width

8-2 Clearance of Radial Ball Bearings

Table 8-3 Radial internal clearance of deep groove ball bearings (cylindrical bore)

Unit: μm

Nominal bore diameter d , mm		Radial internal clearance							
		CN		C3		C4		C5	
over	up to	min.	max.	min.	max.	min.	max.	min.	max.
2.5	6	2	13	8	23	14	29	20	37
6	10	2	13	8	23	14	29	20	37
10	18	3	18	11	25	18	33	25	45
18	24	5	20	13	28	20	36	28	48
24	30	5	20	13	28	23	41	30	53
30	40	6	20	15	33	28	46	40	64
40	50	6	23	18	36	30	51	45	73

Remark) When the above values are used as clearance measurements, the values should be corrected by adding the increase of the radial internal clearances caused by the measuring load. The values to be added are shown below.

Unit: μm

Nominal bore diameter d , mm		Measuring load N	Amounts of clearance correction			
over	up to		CN	C3	C4	C5
2.5	18	24.5	4	4	4	4
18	50	49	5	6	6	6

Table 8-4 Radial internal clearance of extra small/miniature ball bearings

Unit: μm

Clearance code	M3		M4		M5		M6	
	min.	max.	min.	max.	min.	max.	min.	max.
Clearance	5	10	8	13	13	20	20	28

Remark) When the above values are used as clearance measurements, the values should be corrected by adding the increase of the radial internal clearances caused by the measuring load.

Unit: μm

measuring load N	Amounts of clearance correction			
	M3	M4	M5	M6
2.3	1	1	1	1

Remark) Miniature ball bearings: bearing with an outside diameter of less than 9 mm

Small size ball bearings: bearings with an outside diameter of 9 mm or over and a bore diameter of less than 10 mm

Remark) Consult JTEKT regarding the tolerance and internal clearance of inch series bearings (bearing basic number EE3S).

8-3 Tolerance and Internal Clearance of K Series Full Complement Hybrid Ceramic Ball Bearings

Table 8-5 Tolerance and internal clearance of K Series Full Complement Hybrid Ceramic Ball Bearings

Unit: μm

Bore diameter No.	Single plane mean bore diameter deviation Δ_{dmp}		Single plane mean outside diameter deviation Δ_{Dmp}		Single inner or outer ring width deviation Δ_{Bs} , Δ_{Cs}	Radial runout of assembled bearing, max.				S_{ia} , S_{ea}		Radial internal clearance		Bore diameter No.
	class K0		class K0			Inner ring, K_{ia}		Outer ring, K_{ea}		Inner ring	Outer ring	class K0		
	category I		category II			category I		category II		class K0	class K0	Deep groove type	Four point contact type	
	category I		category II			category I		category II		class K0	class K0			
010	0	-10			0 -127	13	8	20	10	Same as the tolerance for the radial runout of the inner ring	Same as the tolerance for the radial runout of the outer ring	25 to 41	25 to 38	010
015	0	-13	0	-13		15	10	20	10			30 to 46	30 to 43	015
020	0	-15				20	13	25	13			30 to 61	30 to 56	020
025	0	-15				25	15	30	15					025
030	0	-15			25					15	30	15	41 to 71	41 to 66
035	0	-20				25	15	30	15			41 to 71	41 to 66	035

S_{ia} , S_{ea} : axial runout of assembled bearing inner or outer ring, max.

[Notes] Category I specifications are applied to deep groove ball bearings.

Category II specifications are applied to angular contact bearings and four point contact ball bearings.

3 Application Examples

- 1 Clean Environments 93
- 2 Vacuum Environments 97
- 3 High Temperature Environments 99
- 4 Corrosive Environments 101
- 5 Magnetic Field Environments 104
- 6 Electric Field Environments 105
- 7 High Speed Applications 107



3
1
Clean Environments

1-1
Transfer Robot for Semiconductor and LCD Manufacturing Equipment

Product: K Series Full Complement Hybrid Ceramic Ball Bearing

For application in transfer robots for semiconductor and liquid crystal manufacturing equipment, bearings are required to be low in particle emissions and have a long service life.

Bearings may be delivered incorporated in arm units for improved assemblability and maintainability.



- Applicable to vacuum environments and clean environments
- Optimal for machine size reduction

■ Use conditions

Lubrication: Grease or clean pro coating
 Temperature: Room temp. to 200°C
 Ambient pressure: 10⁻³ Pa

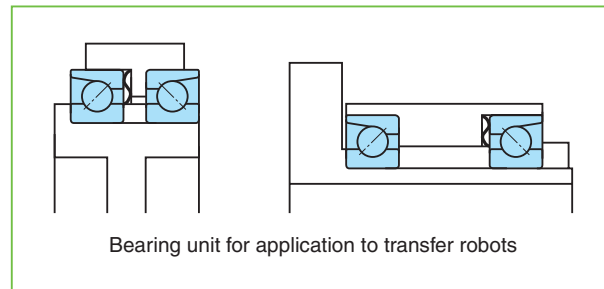

1-2
Conveyor for Sputtering Equipment

Product: Clean Pro Linear Motion Ball Bearing

Clean Pro Linear Motion Ball Bearings are widely used for the conveyers in sputtering equipment.



- Applicable to vacuum environments and clean environments

■ Use conditions

Stroke: 20 mm
 Speed: 10 mm/s
 Lubrication: Clean pro coating
 Temperature: 200°C
 Ambient pressure: Normal to 10⁻⁵ Pa

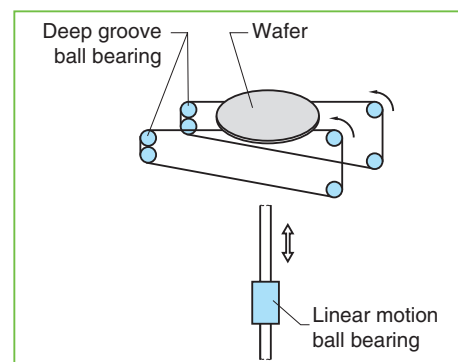

1-3
Gates in Chemical Vapor Deposition Equipment

Product: Hybrid Ceramic Ball Bearing
 Clean Pro Linear Motion Ball Bearing

Hybrid Ceramic Ball Bearings and Clean Pro Linear Motion Ball Bearings are widely used for the doors of the chemical vapor deposition (CVD) equipment.

- Applicable to high temperature, vacuum and clean environments

■ Use conditions

Rotational speed: 10 to 200 min⁻¹
 Lubrication: Clean pro coating
 Temperature: 200°C
 Ambient pressure: Normal to 10⁻⁴ Pa

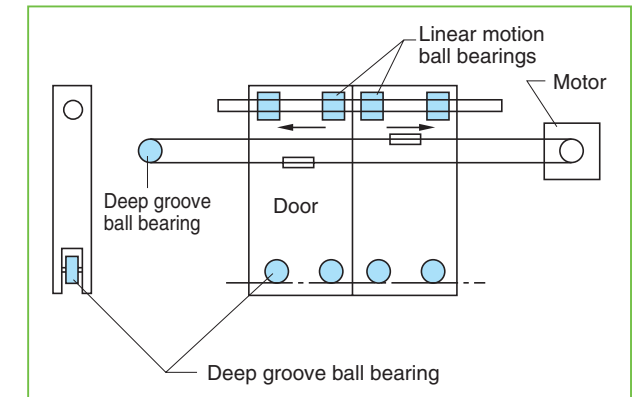

1-4
Chemical Vapor Deposition Machine

Product: Clean Pro Cross Roller Way Bearing Unit

Clean Pro Cross Roller Way Bearing Units are widely used in CVD machines due to their low gas and particle emissions.



- Applicable to vacuum environments and clean environments

■ Use conditions

Stroke: 100 mm
 Lubrication: Clean pro coating
 Temperature: 200°C
 Ambient pressure: Normal to 10⁻³ Pa

1 Clean Environments

1-5 Etching Equipment

Product: Hybrid Ceramic Bearing (with special features)

Bearings used in etching machines must be resistant to halogen, hydrofluoric acid, and other corrosive gasses, as well as low in particle emissions. To meet these requirements, PTFE coated Hybrid Ceramic Bearings are used.

- Resistant to corrosive ambient gases such as halogen and hydrofluoric acid
- Suitable for clean environments thanks to low particle emissions

■ Use conditions

Load: Radial load of 10 N
 Lubrication: PTFE coating
 Temperature: Room temp. to 60°C
 Ambient pressure: Normal to 10⁻² Pa

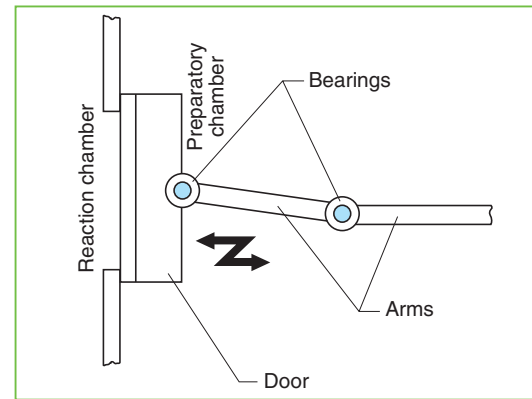

1-6 Sputtering Equipment

Product: High temperature Clean Pro Bearing

Sputtering systems have a high temperature vacuum conveyor, in which High temperature Clean Pro Bearings are used.



- Applicable to a clean environment under high temperature and vacuum conditions

■ Use conditions

Rotational speed: 60 min⁻¹
 Load: Radial load of 100 to 150 N
 Lubrication: High temperature Clean pro coating
 Temperature: Room temp. to 260°C
 Ambient pressure: 10⁻⁵ Pa

1-7 Liquid Crystal Panel Bonding and LC Sealing Furnace

Product: Hybrid Ceramic Linear Motion Ball Bearing

Substrate bonding press jigs for use in furnaces must be low in particle emissions and have a long service life under high temperature conditions.

The Clean Pro Hybrid Ceramic Linear Motion Ball Bearings are widely used for such jigs.



- Suitable for clean environments thanks to low particle emissions

■ Use conditions

Stroke speed: 5 mm/s
 Lubrication: Clean pro coating
 Temperature: 200°C
 Ambient pressure: Normal pressure

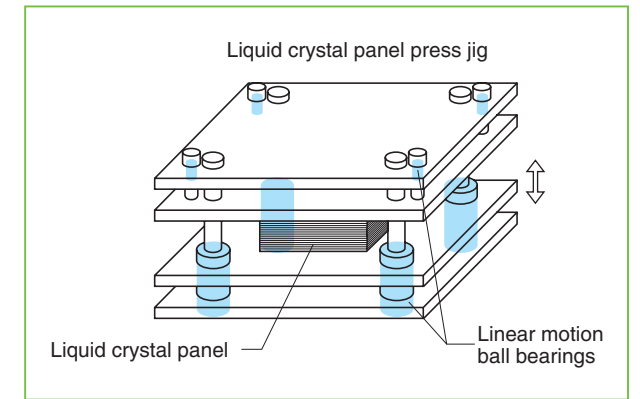

1-8 Wafer Transfer Equipment

Product: Hybrid Ceramic Linear Way Bearing Unit (with special features)

For application in wafer transfer equipment, low particle emissions performance is required.

For such devices, Clean Pro Hybrid Ceramic Linear Way Bearing Units are widely used.



- Suitable for clean environments thanks to low particle emissions
- Corrosion resistant to cleaning agent splashes

■ Use conditions

Stroke speed: 350 mm/s
 Lubrication: Clean pro coating
 Temperature: Room temp.
 Ambient pressure: Normal pressure

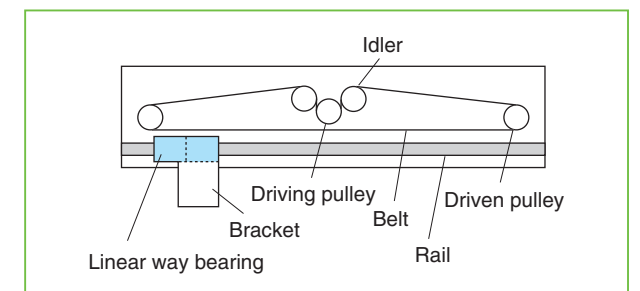

2 Vacuum Environments

2-1 Vacuum Evaporator

Product: High Temperature Hybrid Ceramic Bearing (with special features)

Bearings used in the planetary section of vacuum evaporator are required to be high in durability under high temperatures, high load (moment) conditions. To ensure a long bearing life under high temperature conditions, High temperature Hybrid Ceramic Bearings with special features are used.

- Improved reliability in vacuum and high temperature environments

■ Use conditions

Rotational speed: 1 to 30 min⁻¹
 Lubrication: Molybdenum disulfide or silver
 Temperature: 200 to 400°C
 Ambient pressure: 10⁻⁶ to 10⁻⁸ Pa

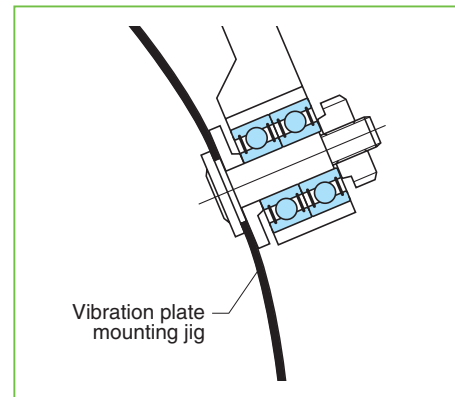

2-2 Turbo Molecular Pump

Product: Full Complement Hybrid Ceramic Ball Bearing (with special features)

Magnetic bearings are used in turbo molecular pumps driven at extremely high speeds. To protect the blades from fracture in case of a power failure or magnetic failure, touchdown bearing units are used. As touchdown bearings, Full Complement Hybrid Ceramic Ball Bearings are used to increase the service life of the touchdown bearings under severe hostile conditions.

- Improved reliability in vacuum environments

■ Use conditions

Rotational speed: 20 000 to 60 000 min⁻¹
 Lubrication: Molybdenum disulfide or silver
 Ambient pressure: 1 Pa

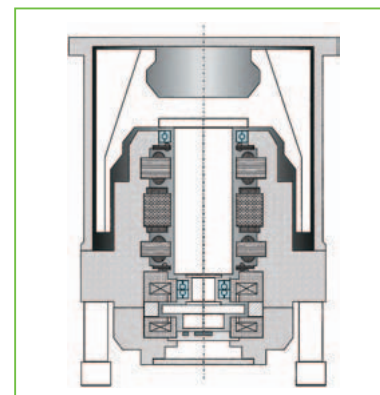

2-3 X-ray Tube

Product: Full Complement Ball Bearing Unit

For rotational anode X-ray tubes, Full Complement Ball Bearing Units, which integrate the flange and shaft.

These bearing units are required to be resistant to vacuum, good high speed performance, heat resistant, and load capacity.



- Improved reliability in vacuum and high temperature environments

■ Use conditions

Rotational speed: 3 000 to 10 000 min⁻¹
 Lubrication: Silver
 Temperature: 250 to 500°C
 Ambient pressure: 10⁻⁵ Pa

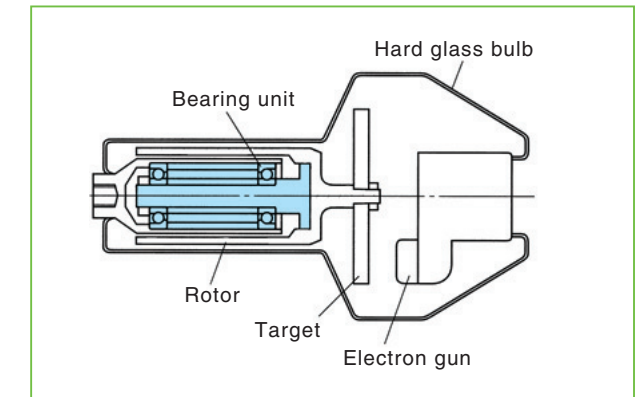

3 High Temperature Environments

Application Examples

3-1 Furnaces Cars

Product: High Temperature Hybrid Ceramic Bearing

The bogies, conveyers and other carrier systems used in furnaces are exposed to high temperatures.

Because of their high heat resistance, High Temperature Hybrid Ceramic Bearings are used in such applications.



- Applicable to high temperature environments

■ Use conditions

Rotational speed: 10 to 500 min⁻¹
 Lubrication: Graphite
 Temperature: 500°C

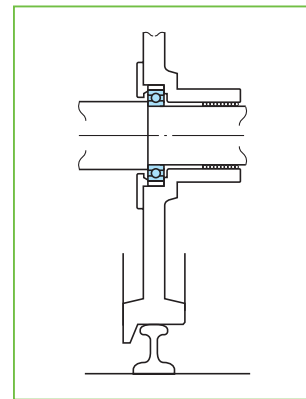

3-2 Carton Manufacturing Equipment

Product: PN Bearing

In carton manufacturing equipment, polyethylene film, which is attached to carton board in advance, is heat bonded by a gas burner in the high temperature gas burner bonding process.

The PN Bearings, which have superior heat resistance, are used to support the guide rollers of the belt that carries carton board in this process, thus avoiding contaminating the carton board with grease.



- Prevention of grease scattering
- Improved durability and reliability under high temperatures

■ Use conditions

Rotational speed: 3 000 to 4 000 min⁻¹
 Lubrication: Molybdenum disulfide and other means
 Temperature: 220°C

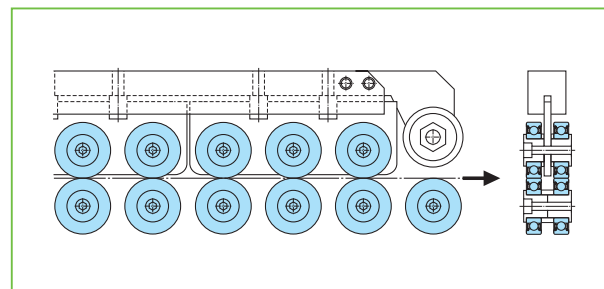

3-3 Baking Furnace Cars

Product: High Temperature Hybrid Ceramic Bearing

In the kiln that bakes fluorine resin onto the heat rollers of copying machines, conveyor bearings must be low in particle emissions under high temperatures. Because it is structurally difficult to mount bearings accurately, High temperature Hybrid Ceramic Bearings are used for this application, along with aligning rings.

- Compatible with high temperature environments

■ Use conditions

Rotational speed: 3 to 10 min⁻¹
 Lubrication: Graphite
 Temperature: 400 to 500°C

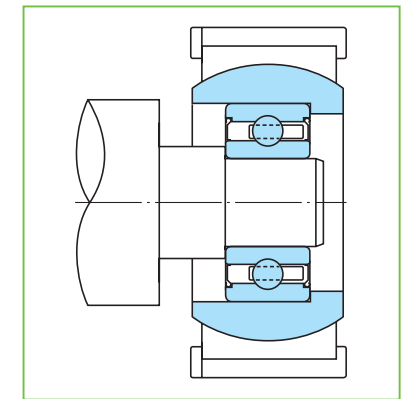

3-4 Tube Annealing Furnace Guide Rolls

Product: Hybrid Ceramic Bearing

The guide roll bearings installed inside tube annealing furnaces are used under high temperatures without lubrication. Hybrid Ceramic Bearings are suitable for such applications.

- Compatible with high temperature environments

■ Use conditions

Rotational speed: 300 min⁻¹
 Temperature: 300°C

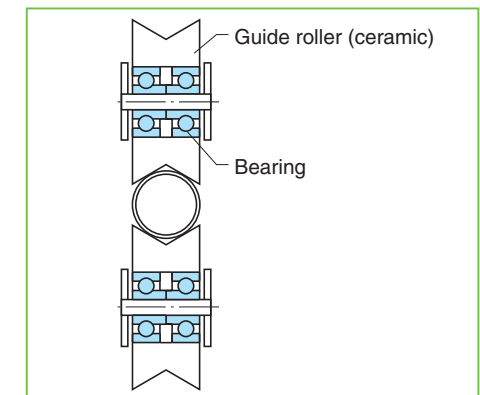

High Temperature Environments

4 Corrosive Environments

4-1

Synthetic Fiber Manufacturing Equipment

Acid solution, alkaline solution, water, and other liquids are used in synthetic fiber yarn reinforcing processes. Corrosion Resistant Hybrid Ceramic Bearings are applied in such corrosive environments.

- Corrosion resistance under acid solution, alkaline solution and water

Product: Corrosion Resistant Hybrid Ceramic Bearing

■ Use conditions

Rotational speed: 20 to 100 min⁻¹
 Lubrication: Chemical solution
 Temperature: Room temp. to 90°C

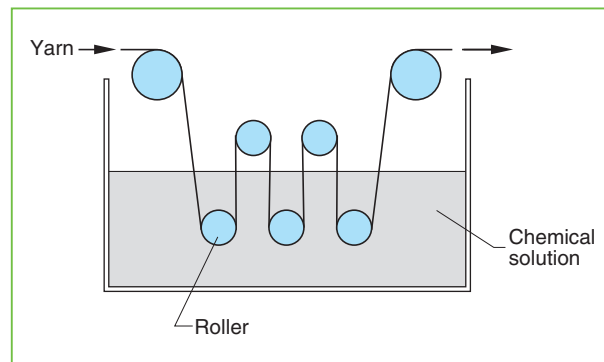

4-2

Blood Centrifuge

Corrosion resistance is required of bearings to be used in blood centrifuge especially to physiological saline.

Hybrid Ceramic Bearings with bearing rings coated with a corrosion resistant film are suitable for such corrosive environments.

- Corrosion resistance to physiological saline

Product: Hybrid Ceramic Bearing (with special coating)

■ Use conditions

Rotational speed: 20 000 min⁻¹
 Lubrication: Grease
 Temperature: -10 to 10°C

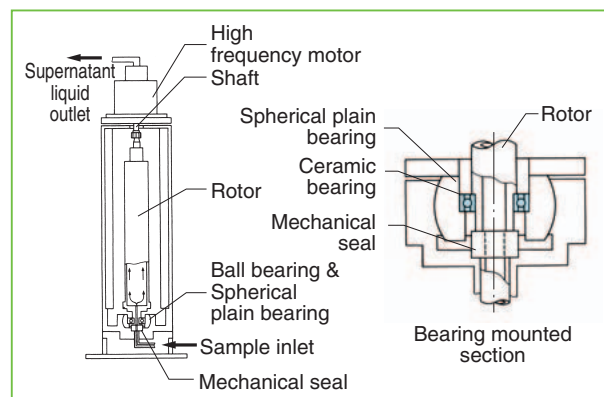

4-3

Aluminum Electrolytic Capacitor Manufacturing Equipment

In an aluminum foil electrolytic capacitor manufacturing equipment, a strong acid solution is used to treat the aluminum foils.

High Corrosion Resistant Ceramic Bearings are widely used in such highly corrosive environments.

- Corrosion resistance to strong acid solution



Product: High Corrosion Resistant Ceramic Bearing

■ Use conditions

Rotational speed: 50 min⁻¹
 Lubrication: Chemical solution (hydrochloric acid and sulfuric acid)
 Temperature: 90°C

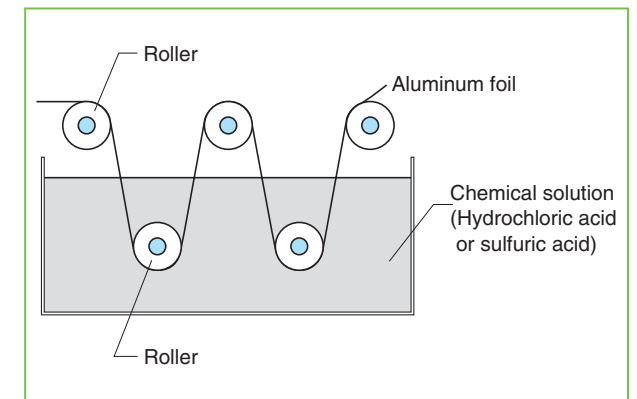

4-4

Liquid Crystal Polarizing Film Manufacturing Equipment

Liquid crystal polarizing film manufacturing equipment use acid solution, alkaline solution, dyeing solution, distilled water, and other solutions.

In such corrosive environments, Corrosion Resistant Hybrid Ceramic Bearings are widely used.

- Corrosion resistance to solutions such as acid solution, alkaline solution, dyeing solution, and distilled water



Product: Corrosion Resistant Hybrid Ceramic Bearing

■ Use conditions

Rotational speed: 80 min⁻¹
 Lubrication: Chemical solution
 Temperature: Room temp. to 80°C

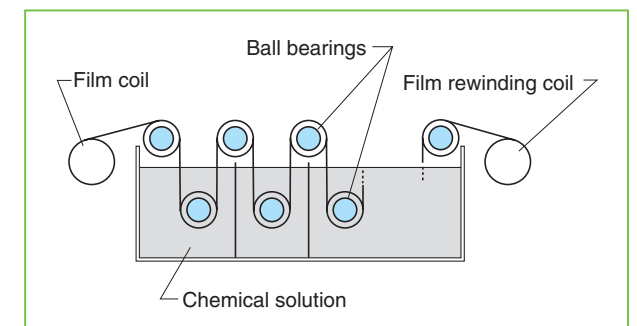

4 Corrosive Environments

4-5

Spin-dryer for Wafer Cleaning Equipment

In semiconductor wafer cleaning processes, wafers are cleaned in cleansing chemicals, rinsing liquids, distilled water, and other liquids before drying.

Because of their high corrosion resistance, Corrosion Resistant Hybrid Ceramic Bearings are widely used in wafer cleaners.



- Corrosion resistance to solutions such as cleaning chemicals, rinsing liquids, and distilled water

Product: Corrosion Resistant Hybrid Ceramic Bearing

■ Use conditions

Rotational speed: 2 000 to 3 000 min⁻¹
 Lubrication: Grease
 Temperature: Room temp.

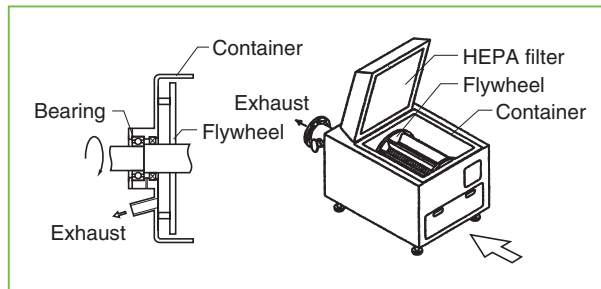

4-6

Wafer Cleaning Equipment for Chemical Mechanical Polishing System

In the semiconductor multilayer production process, each wafer surface should be treated to maintain evenness. This process uses chemical mechanical polishing equipment, and the cleaner attached to the equipment uses Corrosion Resistant Ceramic Bearings.



- Corrosion resistance to corrosive solutions

Product: Corrosion Resistant Ceramic Bearing

■ Use conditions

Rotational speed: 100 min⁻¹
 Lubrication: Fluorine polymer
 Temperature: Room temp.

5 Magnetic Field Environments

5-1

Electron Beam Lithography

The bearings in semiconductor production electron beam lithography are exposed to strong magnetic fields.

Because of their non-magnetic characteristics, Hybrid Ceramic Bearings are used in such machines.



- Compatible with vacuum, strong magnetic field environments

Product: Non-magnetic Hybrid Ceramic Bearing

■ Use conditions

Rotational speed: 100 min⁻¹
 Lubrication: Grease
 Temperature: Room temp.
 Ambient pressure: 10⁻⁵ Pa

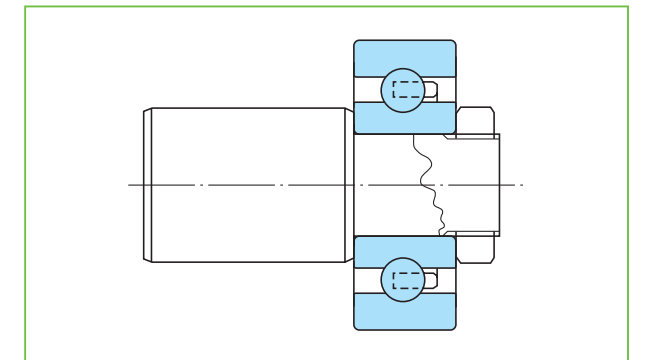

5-2

Ultrasonic Motor in Magnetic Resonance Imagers

The motors installed in magnetic resonance imagers (MRI) use magnetism insensitive Ceramic Bearings.



- Compatible with strong magnetic field environments

Product: Ceramic Bearing

■ Use conditions

Rotational speed: 500 min⁻¹
 Lubrication: Grease
 Temperature: Room temp.

6 Electric Field Environments

6-1 Wind Turbine Generator

Product: Hybrid Ceramic Bearing

Wind Turbine Generator are strongly required to operate for extensive periods of time without the need of maintenance. However, bearings used in generators are subject to electrical pitting, which may cause the bearings to break down.

Hybrid Ceramic Bearings, which have superior durability and reliability, are widely used in such aerogenerators.



- Prevention of electrical pitting
- Extension of grease service life (three times longer than Koyo steel bearings)

■ Use conditions

Rotational speed: 2 700 min⁻¹
 Lubrication: Grease
 Temperature: Below freezing point to approx. 60°C
 Bearing location: Generators



6-2 DVD Sputtering Equipment

Product: Hybrid Ceramic Bearing

To improve reliability further, Hybrid Ceramic Bearings are used.

- Insulation

■ Use conditions

Rotational speed: 300 min⁻¹
 Lubrication: Grease
 Temperature: Room temp.

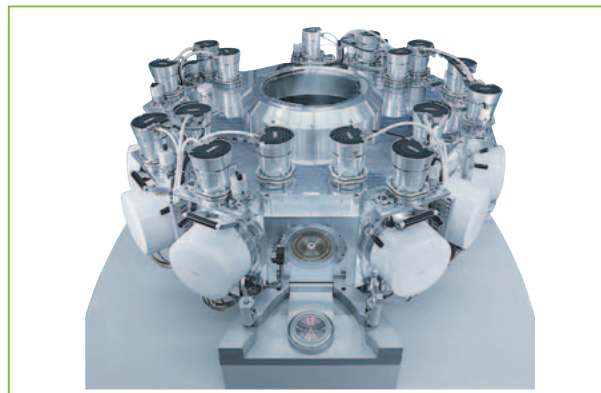

6-3 Motor

Product: Hybrid Ceramic Bearing

Bearings used in motors are susceptible to electrical pitting. Hybrid Ceramic Bearings are widely used to prevent such pitting.



- Prevention of electrical pitting

■ Use conditions

Rotational speed: 5 000 min⁻¹
 Lubrication: Grease
 Temperature: -10 to 120°C



6-4 Photographic Film Manufacturing Equipment

Product: Hybrid Ceramic Bearing (with special features)

A photographic film production line treats film surfaces by applying a high voltage.

Hybrid Ceramic Bearings are widely used in such environments, because the ceramic inner ring and balls serve as insulators.

- Insulation under high voltage environments

■ Use conditions

Rotational speed: 200 min⁻¹
 Lubrication: Grease
 Temperature: Room temp.

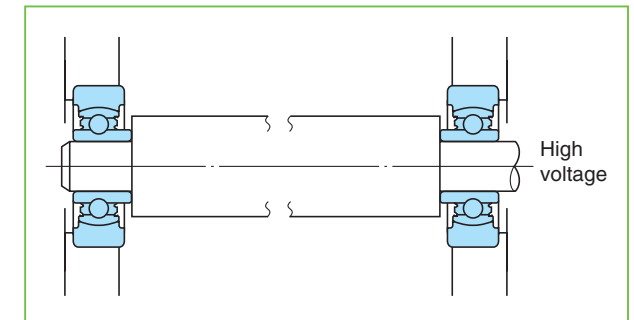

7 High Speed Applications

7-1 Turbocharger

Product: Hybrid Ceramic Bearing

Bearings that support the spindle of turbochargers should have good acceleration response characteristics and high durability under low viscosity, contaminated oil.

Because of their high reliability in these respects, Hybrid Ceramic Bearings are widely used for this application.



- Three times longer service life than that of steel bearings
- Acceleration response up 20%
- An 80% reduction in oil supply

■ Use conditions

Rotational speed: 180 000 to 210 000 min⁻¹
 Lubrication: Grease
 Temperature: 350°C



7-2 Spindle for Machine Tool

Product: Hybrid Ceramic Bearing
 (High Ability Angular Contact Ball Bearing)

Machine tool spindle bearings are required to have superior rotational performance at extremely high speeds, quick acceleration/deceleration, high rigidity, and reduced temperature rises.

Hybrid Ceramic Bearings, which satisfy these requirements, are widely used in this application.



- 20% to 30% reduction in temperature rises
- The upper limit of the rotational speed range is 1.2 to 1.5 times higher (compared with Koyo steel bearings).

■ Use conditions

Rotational speed: 25 000 min⁻¹ ($d_m n = 2.75 \times 10^6$)
 Lubrication: Oil or grease
 Spindle power: 75 kW

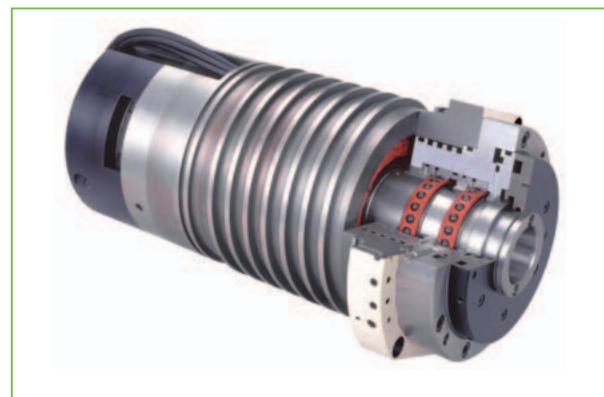

7-3 Polygon Scanner Motor

Product: Hybrid Ceramic Bearing

Hybrid Ceramic Bearings, which exhibit superior high speed performance, are widely used in high speed polygon scanner motors.

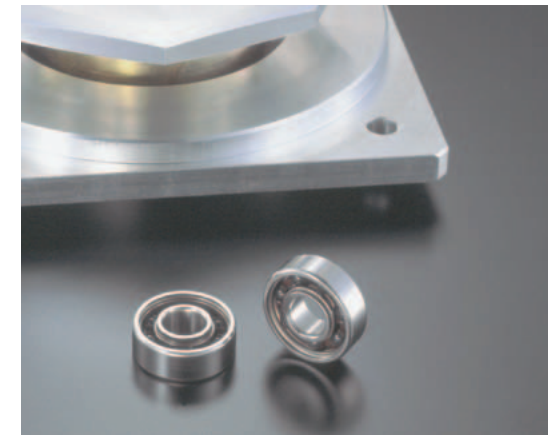

- Excellent reliability in high speed rotation

■ Use conditions

Rotational speed: 26 000 min⁻¹ or higher
 Lubrication: Grease

7-4 Switched Reluctance Motor

Product: Hybrid Ceramic Bearing

For high speed, high efficiency switched reluctance (SR) motors, which do not use coils or permanent magnets, Hybrid Ceramic Bearings are applied.



- Excellent reliability in high speed rotation

■ Use conditions

Rotational speed: 30 000 min⁻¹
 Lubrication: Grease

7 High Speed Applications

7-5 Steel Wire Stranding Machine

Product: Hybrid Ceramic Bearing

Steel wires for radial tires are produced by stranding steel wires to attain the required strength. In steel wire stranding machines, which involve high speed rotation, Hybrid Ceramic Bearings are used for improved service life and stability.



- Reduced temperature rises
- Reliable durability

■ Use conditions

Rotational speed: 6 000 min⁻¹ or higher
Lubrication: Grease

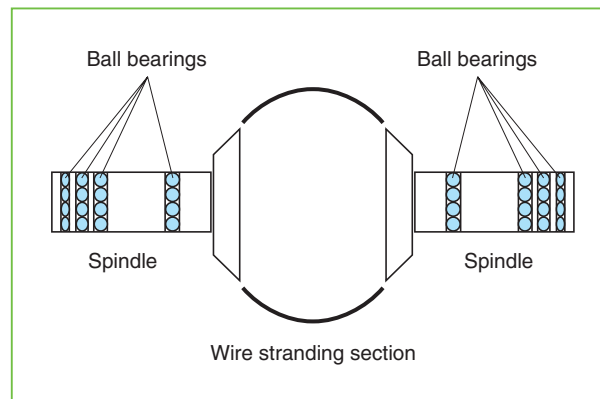

7-6 Jet Electrostatic Coating Machine

Product: Hybrid Ceramic Bearing

In a jet electrostatic coating machine, grease may escape from the spray nozzle due to the air motor, affecting the quality of the paint to be coated.

To resolve this problem, Hybrid Ceramic Bearings that do not use grease are used.



- Prevention of grease scattering
- Prevention of paint contamination

■ Use conditions

Rotational speed: 20 000 min⁻¹
Lubrication: Fluorine polymer

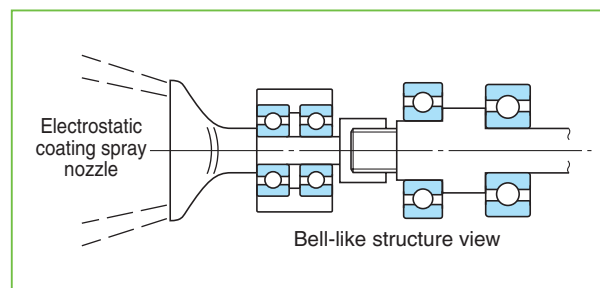

7-7 Inline Skates

Product: Hybrid Ceramic Bearing

Because of their low running torque and high durability, Hybrid Ceramic Bearings are widely used in speed skates.



- Low torque and improved durability

■ Use conditions

Rotational speed: 10 000 min⁻¹
Lubrication: Oil or grease

7-8 Micro Gas Turbine Generator

Product: Hybrid Ceramic Bearing

The world's smallest gas turbine generators emit clean exhaust emissions and hence are friendly to the environment. Hybrid Ceramic Bearings are used in these generators because they are low in vibration and noise generation, and have excellent high speed performance.



- Improved reliability in high speed rotation

■ Use conditions

Rotational speed: 100 000 min⁻¹
(dmn = 2.22 × 10⁶)
Lubrication: Oil
Temperature: 200°C

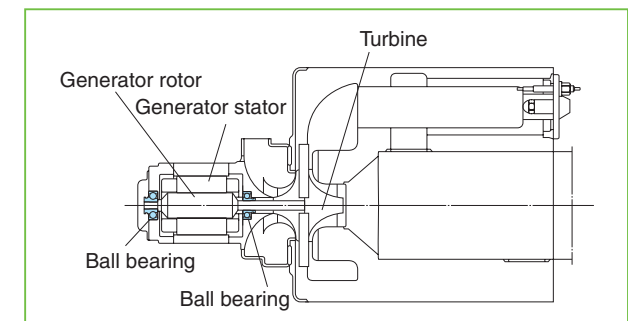

7 High Speed Applications

7-9 Fuel Injection System Control Valve

Product: Ceramic Ball

The common rail system (fuel injection system), which enables diesel engines to feature high power, good fuel economy and low emissions, is equipped with Ceramic Balls in the control valves.

- Compatible with high pressure fuel injection thanks to improved wear resistance and seizure resistance

■ **Use conditions**
Maximum pressure: 135 MPa

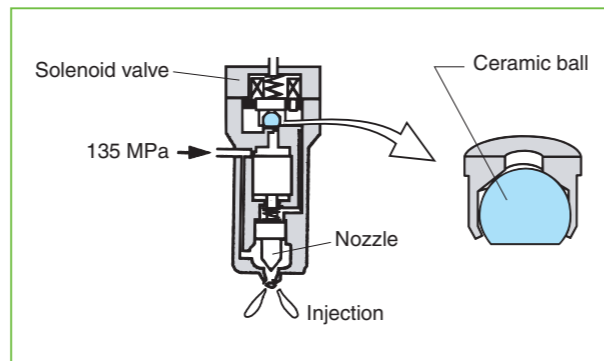

4 Supplementary Tables

1 Shaft Tolerances	113
2 Housing Bore Tolerances	115
3 Numerical Values for Standard Tolerance Grades IT	117
4 Steel Hardness Conversion	118
5 SI Units and Conversion Factors	119
6 Inch / millimeter Conversion	123
7 Cleanliness Classes	124



Supplementary table 1 Shaft tolerances (deviation from nominal dimensions)

Nominal shaft diameter (mm)		Deviation classes of shaft diameter															Nominal shaft diameter (mm)		Unit: μm (Refer.)														
		over	up to	d6	e6	f6	g5	g6	h5	h6	h7	h8	h9	h10	js5	js6	js7	j5	j6	over	up to	$\Delta d_{mp}^{(1)}$ of bearing (class 0)											
3	6	-30	-20	-10	-4	-4	0	0	0	0	0	0	0	0	± 2.5	± 4	± 6	+3	+6	+6	+9	+13	+9	+12	+16	+13	+16	+20	+23	+27	3	6	0
		-38	-28	-18	-9	-12	-5	-8	-12	-18	-30	-48	± 3	± 4.5	± 7.5	+4	+7	+1	+1	+1	+4	+4	+4	+8	+8	+12	+15	+15	-8				
6	10	-40	-25	-13	-5	-5	0	0	0	0	0	0	0	± 3	± 4.5	± 7.5	+4	+7	+7	+10	+16	+12	+15	+21	+16	+19	+24	+28	+34	6	10	0	
		-49	-34	-22	-11	-14	-6	-9	-15	-22	-36	-58	± 4	± 5.5	± 9	+5	+8	+1	+1	+1	+6	+6	+6	+10	+10	+15	+19	+19	-8				
10	18	-50	-32	-16	-6	-6	0	0	0	0	0	0	0	± 4	± 5.5	± 9	+5	+8	+9	+12	+19	+15	+18	+25	+20	+23	+29	+34	+41	10	18	0	
		-61	-43	-27	-14	-17	-8	-11	-18	-27	-43	-70	± 4.5	± 6.5	± 10.5	+6	+9	+1	+1	+1	+7	+7	+7	+12	+12	+18	+18	+23	+23	-8			
18	30	-65	-40	-20	-7	-7	0	0	0	0	0	0	0	± 4.5	± 6.5	± 10.5	+5	+9	+11	+15	+23	+17	+21	+29	+24	+28	+35	+41	+49	18	30	0	
		-78	-53	-33	-16	-20	-9	-13	-21	-33	-52	-84	± 5.5	± 8	± 12.5	+6	+11	+2	+2	+2	+8	+8	+8	+15	+15	+22	+28	+28	-10				
30	50	-80	-50	-25	-9	-9	0	0	0	0	0	0	0	± 5.5	± 8	± 12.5	+6	+11	+13	+18	+27	+20	+25	+34	+28	+33	+42	+50	+59	30	50	0	
		-96	-66	-41	-20	-25	-11	-16	-25	-39	-62	-100	± 6.5	± 9.5	± 15	+6	+12	+2	+2	+2	+9	+9	+9	+17	+17	+26	+34	+34	-12				
50	80	-100	-60	-30	-10	-10	0	0	0	0	0	0	0	± 6.5	± 9.5	± 15	+6	+12	+15	+21	+32	+24	+30	+41	+33	+39	+51	+60	+71	50	80	0	
		-119	-79	-49	-23	-29	-13	-19	-30	-46	-74	-120	± 7.5	± 11	± 17.5	+6	+13	+2	+2	+2	+11	+11	+11	+20	+20	+32	+41	+41	-15				
80	120	-120	-72	-36	-12	-12	0	0	0	0	0	0	0	± 7.5	± 11	± 17.5	+6	+13	+18	+25	+38	+28	+35	+48	+38	+45	+59	+73	+86	80	120	0	
		-142	-94	-58	-27	-34	-15	-22	-35	-54	-87	-140	± 9	± 12.5	± 20	+7	+14	+3	+3	+3	+13	+13	+13	+23	+23	+37	+51	+51	-20				
120	180	-145	-85	-43	-14	-14	0	0	0	0	0	0	0	± 9	± 12.5	± 20	+7	+14	+21	+28	+43	+33	+40	+55	+45	+52	+68	+88	+103	120	180	0	
		-170	-110	-68	-32	-39	-18	-25	-40	-63	-100	-160	± 10	± 14.5	± 23	+7	+16	+3	+3	+3	+15	+15	+15	+27	+27	+43	+65	+65	-25				
180	250	-170	-100	-50	-15	-15	0	0	0	0	0	0	0	± 10	± 14.5	± 23	+7	+16	+24	+33	+50	+37	+46	+63	+51	+60	+79	+106	+123	180	250	0	
		-199	-129	-79	-35	-44	-20	-29	-46	-72	-115	-185	± 11.5	± 16	± 26	+7	+16	+4	+4	+4	+17	+17	+17	+31	+31	+50	+80	+80	-30				
250	315	-190	-110	-56	-17	-17	0	0	0	0	0	0	0	± 11.5	± 16	± 26	+7	+16	+27	+36	+56	+43	+52	+72	+57	+66	+88	+126	+146	250	315	0	
		-222	-142	-88	-40	-49	-23	-32	-52	-81	-130	-210	± 12.5	± 18	± 28.5	+7	+18	+4	+4	+4	+20	+20	+20	+34	+34	+56	+94	+94	-35				
315	400	-210	-125	-62	-18	-18	0	0	0	0	0	0	0	± 12.5	± 18	± 28.5	+7	+18	+29	+40	+61	+46	+57	+78	+62	+73	+98	+144	+165	315	400	0	
		-246	-161	-98	-43	-54	-25	-36	-57	-89	-140	-230	± 13.5	± 20	± 31.5	+7	+20	+4	+4	+4	+21	+21	+21	+37	+37	+62	+108	+108	-40				
400	500	-230	-135	-68	-20	-20	0	0	0	0	0	0	0	± 13.5	± 20	± 31.5	+7	+20	+32	+45	+68	+50	+63	+86	+67	+80	+108	+166	+189	400	500	0	
		-270	-175	-108	-47	-60	-27	-40	-63	-97	-155	-250	± 16	± 22	± 35	+7	+20	+5	+5	+5	+23	+23	+23	+40	+40	+68	+126	+126	-45				
500	630	-260	-145	-76	-22	-22	0	0	0	0	0	0	0	± 16	± 22	± 35	-	-	+32	+44	+70	+58	+70	+96	+76	+88	+122	+194	+220	500	630	0	
		-304	-189	-120	-54	-66	-32	-44	-70	-110	-175	-280	± 18	± 25	± 40	-	-	0	0	0	0	0	+26	+26	+26	+44	+44	+78	+150	+150	-50		
630	800	-290	-160	-80	-24	-24	0	0	0	0	0	0	0	± 18	± 25	± 40	-	-	+36	+50	+80	+66	+80	+110	+86	+100	+138	+225	+255	630	800	0	
		-340	-210	-130	-60	-74	-36	-50	-80	-125	-200	-320	± 20	± 28	± 45	-	-	0	0	0	0	0	+30	+30	+30	+50	+50	+88	+175	+175	-75		
800	1 000	-320	-170	-86	-26	-26	0	0	0	0	0	0	0	± 20	± 28	± 45	-	-	+40	+56	+90	+74	+90	+124	+96	+112	+156	+266	+300	800	900	0	
		-376	-226	-142	-66	-82	-40	-56	-90	-140	-230	-360	± 20	± 28	± 45	-	-	0	0	0	0	0	+34	+34	+34	+56	+56	+100	+210	+210	-100		

Note 1) Δd_{mp} : single plane mean bore diameter deviation

Supplementary table 2 Housing bore tolerances (deviation from nominal dimensions)

Nominal bore diameter (mm)		Deviation classes of housing bore diameter															Unit: μm (Refer.)		$\Delta D_{mp}^{(1)}$ of bearing (class 0)												
		over	up to	E6	F6	F7	G6	G7	H6	H7	H8	H9	H10	JS5	JS6	JS7	J6	J7		K5	K6	K7	M5	M6	M7	N5	N6	N7	P6	P7	R7
10	18	+43	+27	+34	+17	+24	+11	+18	+27	+43	+70	± 4	± 5.5	± 9	+6	+10	+2	+2	+6	-4	-4	0	-9	-9	-5	-15	-11	-16	10	18	0
		+32	+16	+16	+6	+6	0	0	0	0	0	0				-5	-8	-6	-9	-12	-12	-15	-18	-17	-20	-23	-26	-29	-34		
18	30	+53	+33	+41	+20	+28	+13	+21	+33	+52	+84	± 4.5	± 6.5	± 10.5	+8	+12	+1	+2	+6	-5	-4	0	-12	-11	-7	-18	-14	-20	18	30	0
		+40	+20	+20	+7	+7	0	0	0	0	0	0				-5	-9	-8	-11	-15	-14	-17	-21	-21	-24	-28	-31	-35	-41		
30	50	+66	+41	+50	+25	+34	+16	+25	+39	+62	+100	± 5.5	± 8	± 12.5	+10	+14	+2	+3	+7	-5	-4	0	-13	-12	-8	-21	-17	-25	30	50	0
		+50	+25	+25	+9	+9	0	0	0	0	0	0				-6	-11	-9	-13	-18	-16	-20	-25	-24	-28	-33	-37	-42	-50		
50	80	+79	+49	+60	+29	+40	+19	+30	+46	+74	+120	± 6.5	± 9.5	± 15	+13	+18	+3	+4	+9	-6	-5	0	-15	-14	-9	-26	-21	-30	50	80	0
		+60	+30	+30	+10	+10	0	0	0	0	0	0				-6	-12	-10	-15	-21	-19	-24	-30	-28	-33	-39	-45	-51	-60		
80	120	+94	+58	+71	+34	+47	+22	+35	+54	+87	+140	± 7.5	± 11	± 17.5	+16	+22	+2	+4	+10	-8	-6	0	-18	-16	-10	-30	-24	-38	80	120	0
		+72	+36	+36	+12	+12	0	0	0	0	0	0				-6	-13	-13	-18	-25	-23	-28	-35	-33	-38	-45	-52	-59	-41		
120	180	+110	+68	+83	+39	+54	+25	+40	+63	+100	+160	± 9	± 12.5	± 20	+18	+26	+3	+4	+12	-9	-8	0	-21	-20	-12	-36	-28	-48	120	180	0
		+85	+43	+43	+14	+14	0	0	0	0	0	0				-7	-14	-15	-21	-28	-27	-33	-40	-39	-45	-52	-61	-68	-50		
180	250	+129	+79	+96	+44	+61	+29	+46	+72	+115	+185	± 10	± 14.5	± 23	+22	+30	+2	+5	+13	-11	-8	0	-25	-22	-14	-41	-33	-60	180	250	0
		+100	+50	+50	+15	+15	0	0	0	0	0	0				-7	-16	-18	-24	-33	-31	-37	-46	-45	-51	-60	-70	-79	-63		
250	315	+142	+88	+108	+49	+69	+32	+52	+81	+130	+210	± 11.5	± 16	± 26	+25	+36	+3	+5	+16	-13	-9	0	-27	-25	-14	-47	-36	-74	250	315	0
		+110	+56	+56	+17	+17	0	0	0	0	0	0				-7	-16	-20	-27	-36	-36	-41	-52	-50	-57	-66	-79	-88	-126		
315	400	+161	+98	+119	+54	+75	+36	+57	+89	+140	+230	± 12.5	± 18	± 28.5	+29	+39	+3	+7	+17	-14	-10	0	-30	-26	-16	-51	-41	-87	315	400	0
		+125	+62	+62	+18	+18	0	0	0	0	0	0				-7	-18	-22	-29	-40	-39	-46	-57	-55	-62	-73	-87	-98	-144		
400	500	+175	+108	+131	+60	+83	+40	+63	+97	+155	+250	± 13.5	± 20	± 31.5	+33	+43	+2	+8	+18	-16	-10	0	-33	-27	-17	-55	-45	-103	400	500	0
		+135	+68	+68	+20	+20	0	0	0	0	0	0				-7	-20	-25	-32	-45	-43	-50	-63	-60	-67	-80	-95	-108	-166		
500	630	+189	+120	+146	+66	+92	+44	+70	+110	+175	+280	± 16	± 22	± 35	-	-	0	0	0	-26	-26	-26	-44	-44	-44	-78	-78	-150	500	630	0
		+145	+76	+76	+22	+22	0	0	0	0	0	0				-	-	-32	-44	-70	-58	-70	-96	-76	-88	-114	-122	-148	-220		
630	800	+210	+130	+160	+74	+104	+50	+80	+125	+200	+320	± 18	± 25	± 40	-	-	0	0	0	-30	-30	-30	-50	-50	-50	-88	-88	-175	630	800	0
		+160	+80	+80	+24	+24	0	0	0	0	0	0				-	-	-36	-50	-80	-66	-80	-110	-86	-100	-130	-138	-168	-255		
800	1 000	+226	+142	+176	+82	+116	+56	+90	+140	+230	+360	± 20	± 28	± 45	-	-	0	0	0	-34	-34	-34	-56	-56	-56	-100	-100	-210	800	900	0
		+170	+86	+86	+26	+26	0	0	0	0	0	0				-	-	-40	-56	-90	-74	-90	-124	-96	-112	-146	-156	-190	-300		
1 000	1 250	+261	+164	+203	+94	+133	+66	+105	+165	+260	+420	± 23.5	± 33	± 52.5	-	-	0	0	0	-40	-40	-40	-66	-66	-66	-120	-120	-250	1 000	1 250	0
		+195	+98	+98	+28	+28	0	0	0	0	0	0				-	-	-47	-66	-105	-87	-106	-145	-113	-132	-171	-186	-225	-355		

Note 1) ΔD_{mp} : single plane mean outside diameter deviation

Supplementary table 3 Numerical values for standard tolerance grades IT

Basic size (mm)		Standard tolerance grades (IT)																	
		1	2	3	4	5	6	7	8	9	10	11	12	13	14 ¹⁾	15 ¹⁾	16 ¹⁾	17 ¹⁾	18 ¹⁾
over	up to	Tolerances (μm)									Tolerances (mm)								
—	3	0.8	1.2	2	3	4	6	10	14	25	40	60	0.10	0.14	0.26	0.40	0.60	1.00	1.40
3	6	1	1.5	2.5	4	5	8	12	18	30	48	75	0.12	0.18	0.30	0.48	0.75	1.20	1.80
6	10	1	1.5	2.5	4	6	9	15	22	36	58	90	0.15	0.22	0.36	0.58	0.90	1.50	2.20
10	18	1.2	2	3	5	8	11	18	27	43	70	110	0.18	0.27	0.43	0.70	1.10	1.80	2.70
18	30	1.5	2.5	4	6	9	13	21	33	52	84	130	0.21	0.33	0.52	0.84	1.30	2.10	3.30
30	50	1.5	2.5	4	7	11	16	25	39	62	100	160	0.25	0.39	0.62	1.00	1.60	2.50	3.90
50	80	2	3	5	8	13	19	30	46	74	120	190	0.30	0.46	0.74	1.20	1.90	3.00	4.60
80	120	2.5	4	6	10	15	22	35	54	87	140	220	0.35	0.54	0.87	1.40	2.20	3.50	5.40
120	180	3.5	5	8	12	18	25	40	63	100	160	250	0.40	0.63	1.00	1.60	2.50	4.00	6.30
180	250	4.5	7	10	14	20	29	46	72	115	185	290	0.46	0.72	1.15	1.85	2.90	4.60	7.20
250	315	6	8	12	16	23	32	52	81	130	210	320	0.52	0.81	1.30	2.10	3.20	5.20	8.10
315	400	7	9	13	18	25	36	57	89	140	230	360	0.57	0.89	1.40	2.30	3.60	5.70	8.90
400	500	8	10	15	20	27	40	63	97	155	250	400	0.63	0.97	1.55	2.50	4.00	6.30	9.70
500	630	—	—	—	—	—	44	70	110	175	280	440	0.70	1.10	1.75	2.80	4.40	7.00	11.00
630	800	—	—	—	—	—	50	80	125	200	320	500	0.80	1.25	2.00	3.20	5.00	8.00	12.50
800	1 000	—	—	—	—	—	56	90	140	230	360	560	0.90	1.40	2.30	3.60	5.60	9.00	14.00
1 000	1 250	—	—	—	—	—	66	105	165	260	420	660	1.05	1.65	2.60	4.20	6.60	10.50	16.50
1 250	1 600	—	—	—	—	—	78	125	195	310	500	780	1.25	1.95	3.10	5.00	7.80	12.50	19.50
1 600	2 000	—	—	—	—	—	92	150	230	370	600	920	1.50	2.30	3.70	6.00	9.20	15.00	23.00
2 000	2 500	—	—	—	—	—	110	175	280	440	700	1 100	1.75	2.80	4.40	7.00	11.00	17.50	28.00
2 500	3 150	—	—	—	—	—	135	210	330	540	860	1 350	2.10	3.30	5.40	8.60	13.50	21.00	33.00

Note 1) Standard tolerance grades IT 14 to IT 18 (incl.) shall not be used for basic sizes less than or equal to 1 mm.

Supplementary table 4 Steel hardness conversion

Rockwell C-scale 1471.0 N	Vicker's	Brinell		Rockwell		Shore
		Standard ball	Tungsten carbide ball	A-scale 588.4 N	B-scale 980.7 N	
68	940			85.6		97
67	900			85.0		95
66	865			84.5		92
65	832		739	83.9		91
64	800		722	83.4		88
63	772		705	82.8		87
62	746		688	82.3		85
61	720		670	81.8		83
60	697		654	81.2		81
59	674		634	80.7		80
58	653		615	80.1		78
57	633		595	79.6		76
56	613		577	79.0		75
55	595	—	560	78.5		74
54	577	—	543	78.0		72
53	560	—	525	77.4		71
52	544	500	512	76.8		69
51	528	487	496	76.3		68
50	513	475	481	75.9		67
49	498	464	469	75.2		66
48	484	451	455	74.7		64
47	471	442	443	74.1		63
46	458	432	432	73.6		62
45	446		421	73.1		60
44	434		409	72.5		58
43	423		400	72.0		57
42	412		390	71.5		56
41	402		381	70.9		55
40	392		371	70.4	—	54
39	382		362	69.9	—	52
38	372		353	69.4	—	51
37	363		344	68.9	—	50
36	354		336	68.4	(109.0)	49
35	345		327	67.9	(108.5)	48
34	336		319	67.4	(108.0)	47
33	327		311	66.8	(107.5)	46
32	318		301	66.3	(107.0)	44
31	310		294	65.8	(106.0)	43
30	302		286	65.3	(105.5)	42
29	294		279	64.7	(104.5)	41
28	286		271	64.3	(104.0)	41
27	279		264	63.8	(103.0)	40
26	272		258	63.3	(102.5)	38
25	266		253	62.8	(101.5)	38
24	260		247	62.4	(101.0)	37
23	254		243	62.0	100.0	36
22	248		237	61.5	99.0	35
21	243		231	61.0	98.5	35
20	238		226	60.5	97.8	34
(18)	230		219	—	96.7	33
(16)	222		212	—	95.5	32
(14)	213		203	—	93.9	31
(12)	204		194	—	92.3	29
(10)	196		187		90.7	28
(8)	188		179		89.5	27
(6)	180		171		87.1	26
(4)	173		165		85.5	25
(2)	166		158		83.5	24
(0)	160		152		81.7	24

Supplementary table 5(1) SI units and conversion factors

Mass	SI units	Other Units ¹⁾	Conversion into SI units	Conversion from SI units
Angle	rad [radian(s)]	° [degree(s)] * ′ [minute(s)] * ″ [second(s)] *	1° =π/180 rad 1′ =π/10 800 rad 1″ =π/648 000 rad	1 rad=57.295 78°
Length	m [meter(s)]	Å [Angstrom unit] μ [micron(s)] in [inch(es)] ft [foot(feet)] yd [yard(s)] mile [mile(s)]	1Å=10 ⁻¹⁰ m=0.1 nm=100pm 1 μ=1 μ m 1 in=25.4 mm 1 ft=12 in=0.304 8 m 1 yd=3 ft=0.914 4 m 1 mile=5 280 ft=1 609.344 m	1 m=10 ¹⁰ Å 1 m=39.37 in 1 m=3.280 8 ft 1 m=1.093 6 yd 1 km=0.621 4 mile
Area	m ²	a [are(s)] ha [hectare(s)] acre [acre(s)]	1 a=100m ² 1 ha=10 ⁴ m ² 1 acre=4 840 yd ² =4 046.86 m ²	1 km ² =247.1 acre
Volume	m ³	ℓ , L [liter(s)] * cc [cubic centimeters] gal (US) [gallon(s)] froz (US) [fluid ounce(s)] barrel (US) [barrels(US)]	1 ℓ =1 dm ³ =10 ⁻³ m ³ 1 cc=1 cm ³ =10 ⁻⁶ m ³ 1 gal (US)=231 in ³ =3.785 41 dm ³ 1 froz (US)=29.573 5 cm ³ 1 barrel (US)=158.987 dm ³	1 m ³ =10 ³ ℓ 1 m ³ =10 ⁶ cc 1 m ³ =264.17 gal 1 m ³ =33 814 froz 1 m ³ =6.289 8 barrel
Time	s [second(s)]	min [minute(s)] * h [hour(s)] * d [day(s)] *		
Angular velocity	rad/s			
Velocity	m/s	kn [knot(s)] m/h *	1 kn=1 852 m/h	1 km/h=0.539 96 kn
Acceleration	m/s ²	G	1 G=9,806 65 m/s ²	1 m/s ² =0.101 97 G
Frequency	Hz [hertz]	c/s [cycle(s)/second]	1 c/s=1 s ⁻¹ =1 Hz	
Rotation frequency	s ⁻¹	rpm [revolutions per minute] min ⁻¹ * r/min	1 rpm=1/60 s ⁻¹	1 s ⁻¹ =60 rpm
Mass	kg [kilogram(s)]	t [ton(s)] * lb [pound(s)] gr [grain(s)] oz [ounce(s)] ton (UK) [ton(s) (UK)] ton (US) [ton(s) (US)] car [carat(s)]	1 t=10 ³ kg 1 lb=0.453 592 37 kg 1 gr=64.798 91 mg 1 oz=1/16 lb=28.349 5 g 1 ton (UK)=1 016.05 kg 1 ton (US)=907.185 kg 1 car=200 mg	1kg=2,204 6 lb 1 g=15.432 4 gr 1kg=35.274 0 oz 1 t=0.984 2 ton (UK) 1 t=1.102 3 ton (US) 1 g=5 car

Note 1) *: Unit can be used as an SI unit.
No asterisk : Unit cannot be used.

Supplementary table 5(2) SI units and conversion factors

Mass	SI units	Other Units ¹⁾	Conversion into SI units	Conversion from SI units
Density	kg/m ³			
Linear density	kg/m			
Momentum	kg · m/s			
Moment of momentum, angular momentum	kg · m ² /s			
Moment of inertia		kg · m ²		
Force	N [newton(s)]	dyn [dyne(s)] kgf [kilogram-force] gf [gram-force] tf [ton-force] lbf [pound-force]	1 dyn =10 ⁻⁵ N 1 kgf =9.806 65 N 1 gf =9.806 65×10 ⁻³ N 1 tf =9.806 65×10 ³ N 1 lbf =4.448 22 N	1 N=10 ⁵ dyn 1 N=0.101 97 kgf 1 N=0.224 809 lbf
Moment of force	N · m [Newton meter(s)]	gf · cm kgf · cm kgf · m tf · m lbf · ft	1 gf·cm =9,806 65×10 ⁻⁵ N · m 1 kgf·cm =9,806 65×10 ⁻² N · m 1 kgf·m =9,806 65 N · m 1 tf·m =9,806 65×10 ³ N · m 1 lbf·ft =1.355 82 N · m	1 N · m=0.101 97 kgf · m 1 N · m=0.737 56 lbf · ft
Pressure, Normal stress	Pa [Pascal(s)] or N/m ² {1 Pa=1 N/m ² }	gf/cm ² kgf/mm ² kgf/m ² lbf/in ² bar [bar(s)] at [engineering air pressure] mH ₂ O, mAq [meter water column] atm [atmosphere] mHg [meter mercury column] Torr [torr]	1 gf/cm ² =9,806 65×10 Pa 1 kgf/mm ² =9,806 65×10 ⁶ Pa 1 kgf/m ² =9,806 65 Pa 1 lbf/in ² =6 894.76 Pa 1 bar=10 ⁵ Pa 1 at=1 kgf/cm ² =9,806 65×10 ⁴ Pa 1 mH ₂ O=9,806 65×10 ³ Pa 1 atm =101 325 Pa 1 mHg = $\frac{101\ 325}{0.76}$ Pa 1 Torr =1 mmHg=133.322 Pa	1 MPa =0.101 97 kgf/mm ² 1 Pa =0.101 97 kgf/m ² 1 Pa =0.145×10 ⁻³ lbf/in ² 1 Pa =10 ⁻² mbar 1 Pa=7,500 6×10 ⁻³ Torr
Viscosity	Pa · s [pascal second]	P [poise] kgf · s/m ²	10 ⁻² P=1 cP=1 mPa · s 1 kgf · s/m ² =9,806 65 Pa · s	1 Pa · s=0.101 97 kgf · s/m ²
Kinematic viscosity	m ² /s	St [stokes]	10 ⁻² St=1 cSt=1 mm ² /s	
Surface tension	N/m			

Supplementary table 5(3) SI units and conversion factors

Mass	SI units	Other Units ¹⁾	Conversion into SI units	Conversion from SI units
Work, energy	J [joule(s)] {1 J=1 N · m}	eV [electron volt(s)] * erg [erg(s)] kgf · m lbf · ft	1 eV=(1,602 189 2± 0,000 004 6)×10 ⁻¹⁹ J 1 erg=10 ⁻⁷ J 1 kgf · m =9,806 65 J 1 lbf · ft =1,355 82 J	1 J=10 ⁷ erg 1 J=0,101 97 kgf · m 1 J=0,737 56 lbf · ft
Power	W [watt(s)]	erg/s [ergs per second] kgf · m/s PS [French horse-power] HP [horse-power (British)] lbf · ft/s	1 erg/s=10 ⁻⁷ W 1 kgf · m/s=9,806 65 W 1 PS=75 kgf · m/s=735,5 W 1 HP=550 lbf · ft/s=745,7 W 1 lbf · ft/s=1,355 82 W	1 W=0,101 97 kgf · m/s 1 W=0,001 36 PS 1 W=0,001 34 HP
Thermo-dynamic temperature	K [kelvin(s)]			
Celsius temperature	°C [Celsius(s)] {t°C=(t+273,15)K}	°F [degree(s) Fahrenheit]	t°F= $\frac{5}{9}(t-32)°C$	t°C=($\frac{9}{5}t+32$)°F
Linear expansion coefficient	K ⁻¹	°C ⁻¹ [per degree]		
Heat	J [joule(s)] {1 J=1 N · m}	erg [erg(s)] kgf · m cal _{IT} [I. T. calories]	1 erg=10 ⁻⁷ J 1 cal=4,186 8 J 1 Mcal _{IT} =1,163 kW · h	1 J=10 ⁷ erg 1 J=0,238 85 cal _{IT} 1 kW · h=0,86×10 ⁶ cal _{IT}
Thermal conductivity	W/(m · K)	W/(m · °C) cal/(s · m · °C)	1 W/(m · °C)=1 W/(m · K) 1 cal/(s · m · °C)= 4,186 05 W/(m · K)	
Coefficient of heat transfer	W/(m ² · K)	W/(m ² · °C) cal/(s · m ² · °C)	1 W/(m ² · °C)=1 W/(m ² · K) 1 cal/(s · m ² · °C)= 4,186 05 W/(m ² · K)	
Heat capacity	J/K	J/°C	1 J/°C=1 J/K	
Massic heat capacity	J/(kg · K)	J/(kg · °C)		

Note 1) * : Unit can be used as an SI unit.
No asterisk : Unit cannot be used.

Supplementary table 5(4) SI units and conversion factors

Mass	SI units	Other Units ¹⁾	Conversion into SI units	Conversion from SI units
Electric current	A [ampere(s)]			
Electric charge, quantity of electricity	C [coulomb(s)] {1 C=1 A · s}	A · h *	1 A · h=3,6 kC	
Tension, electric potential	V [volt(s)] {1 V=1 W/A}			
Capacitance	F [farad(s)] {1 F=1 C/V}			
Magnetic field strength	A/m	Oe [oersted(s)]	1 Oe= $\frac{10^3}{4\pi}$ A/m	1 A/m=4 π ×10 ⁻³ Oe
Magnetic flux density	T [tesla(s)] { 1 T=1 N/(A · m) =1 Wb/m ² =1 V·s/m ² }	Gs [gauss(es)] γ [gamma(s)]	1 Gs=10 ⁻⁴ T 1 γ=10 ⁻⁹ T	1 T=10 ⁴ Gs 1 T=10 ⁹ γ
Magnetic flux	Wb [weber(s)] {1 Wb=1 V · s}	Mx [maxwell(s)]	1 Mx=10 ⁻⁸ Wb	1 Wb=10 ⁸ Mx
Self inductance	H [henry (-ries)] {1 H=1 Wb/A}			
Resistance (to direct current)	Ω [ohm(s)] {1 Ω=1 V/A}			
Conductance (to direct current)	S [siemens] {1 S=1 A/V}			
Active power	W { 1 W=1 J/s =1 A·V }			

Company name _____ Division, department, and section _____

Name of staff member in charge _____ Phone _____ FAX _____

Koyo Extreme Special Environments Specifications Sheet for Ceramic Bearings and/or EXSEV Bearings

Note: For the selection of the most suitable bearing this sheet must be completed in as much detail as possible. Date _____

Bearing size and bearing number									
Application	a. For new design b. For repair								
Required performance	a. Life b. High speed c. Low dust generation d. Vacuum e. Corrosion resistance f. High temperature g. Non-magnetism h. Insulation i. Others ()								
Operating condition	Operation	a. Dual-directional b. Continuous c. Intermittent		Running time	· 24 h/day				
	Rotation speed, min ⁻¹	a. Inner ring rotating b. Outer ring rotating			· h/day				
		min. : max. : Normal :		· Other ()					
	Load N	Radial :			Fitting	Material	Tolerance		
		Axial :						Shaft	Surface roughness
		Moment :						Housing	
Environment	Temperature: Normal , max.		Humidity:		Cleanness:				
	Pressure: Pa a. Atmospheric b. Atmospheric ⇔ vacuum c. Vacuum d. Other ()								
	Corrosive gas:								
	Corrosive liquid:								
Present condition	Bearing material:								
	Lubrication:			Lubricant:					
	Bearing life:								
	Failure condition:								
Rough sketch of bearing mounting section and/or other remarks									

• By this sheet, the ceramic and/or EXSEV bearings most suitable to operating conditions can be created.

Company name _____ Division, department, and section _____

Name of staff member in charge _____ Phone _____ FAX _____

Koyo Extreme Special Environments Specifications Sheet for Linear Motion Bearings

Note: For the selection of the most suitable bearing this sheet must be completed in as much detail as possible. Date _____

Bearing size and bearing number							
Application	a. For new design b. For repair						
Required performance	a. Life b. High speed c. Low dust generation d. Vacuum e. Corrosion resistance f. High temperature g. Non-magnetism h. Insulation i. Others ()						
Operating condition	Linear motion speed, mm/s	min. :		Running time	· 24 h/day		
		max. :			· h/day		
		Normal :			· Other ()		
	Stroke, mm				Drive system		
	Load N	Bearing loaded :					
		Moment : Other :					
Environment	Temperature: Normal , max.		Humidity:		Cleanness:		
	Pressure: Pa a. Atmospheric b. Atmospheric ⇔ vacuum c. Vacuum d. Other ()						
	Corrosive gas:						
	Corrosive liquid:						
Present condition	Bearing material:						
	Lubrication:			Lubricant:			
	Bearing life:						
	Failure condition:						
Rough sketch of bearing mounting section and/or other remarks							

• By this sheet, the linear motion bearings most suitable to operating conditions can be created.

GLOBAL NETWORK

BEARING BUSINESS OPERATIONS

JTEKT CORPORATION NAGOYA HEAD OFFICE

No.7-1, Meieki 4-chome, Nakamura-ku, Nagoya, Aichi 450-8515,
JAPAN
TEL : 81-52-527-1900
FAX : 81-52-527-1911

JTEKT CORPORATION OSAKA HEAD OFFICE

No.5-8, Minamisemba 3-chome, Chuo-ku, Osaka 542-8502,
JAPAN
TEL : 81-6-6271-8451
FAX : 81-6-6245-3712

Sales & Marketing Headquarters

No.5-8, Minamisemba 3-chome, Chuo-ku, Osaka 542-8502,
JAPAN
TEL : 81-6-6245-6087
FAX : 81-6-6244-9007

OFFICES

KOYO CANADA INC.

5324 South Service Road, Burlington, Ontario L7L 5H5, CANADA
TEL : 1-905-681-1121
FAX : 1-905-681-1392

KOYO CORPORATION OF U.S.A.

-Cleveland Office-

29570 Clemens Road, P.O.Box 45028, Westlake,
OH 44145, U.S.A.
TEL : 1-440-835-1000
FAX : 1-440-835-9347

-Detroit Office-

47771 Halyard Drive, Plymouth, MI 48170, U.S.A.
TEL : 1-734-454-1500
FAX : 1-734-454-4076

KOYO MEXICANA, S.A. DE C.V.

Av. Insurgentes Sur 2376-505, Col. Chimalistac, Del. Álvaro
Obregón, C.P. 01070, México, D.F.
TEL : 52-55-5207-3860
FAX : 52-55-5207-3873

KOYO LATIN AMERICA, S.A.

Edificio Banco del Pacifico Planta Baja, Calle Aquilino de la
Guardia y Calle 52, Panama, REPUBLICA DE PANAMA
TEL : 507-208-5900
FAX : 507-264-2782/507-269-7578

KOYO ROLAMENTOS DO BRASIL LTDA.

Av. Reboucas 2472 Jardim America, Sao Paulo, BRASIL
TEL : 55-11-3372-7500
FAX : 55-11-3887-3039

KOYO BEARINGS INDIA PVT. LTD.

C/o Stylus Commercial Services PVT LTD, Ground Floor, The
Beech, E-1, Manyata Embassy Business Park, Outer Ring Road,
Bengaluru-560045, INDIA
TEL : 91-80-4276-4567 (Reception Desk of Service Office)
FAX : 91-80-4276-4568

JTEKT (THAILAND) CO., LTD.

172/1 Moo 12 Tambol Bangwua, Amphur Bangpakong,
Chachoengsao 24180, THAILAND
TEL : 66-38-830-571/578
FAX : 66-38-830-579

PT. JTEKT INDONESIA

d/a. MM2100 Industrial Town Block DD-3, Cikarang Barat, Bekasi
17520, INDONESIA
TEL : 62-21-8998-3273
FAX : 62-21-8998-3274

KOYO SINGAPORE BEARING (PTE.) LTD.

27, Penjuru Lane, #09-01 C&P Logistics Hub 2, SINGAPORE
609195
TEL : 65-6274-2200
FAX : 65-6862-1623

KOYO MIDDLE EAST FZCO

6EA 601, Dubai Airport Free Zone, P.O. Box 54816, Dubai,
U.A.E.
TEL : 97-1-4299-3600
FAX : 97-1-4299-3700

PHILIPPINE KOYO BEARING CORPORATION

6th Floor, One World Square Building, #10 Upper McKinley
Road, McKinley Town Center Fort Bonifacio, 1634 Taguig City,
PHILIPPINES
TEL : 63-2-856-5046/5047
FAX : 63-2-856-5045

JTEKT KOREA CO., LTD.

Inwoo Building 6F, 539-11, Shinsa-dong, Gangnam-Gu, Seoul,
KOREA
TEL : 82-2-549-7922
FAX : 82-2-549-7923

JTEKT (CHINA) CO., LTD.

Room.25A2, V-CAPITAL Building, 333 Xianxia Road, Changning
District, Shanghai 200336, CHINA
TEL : 86-21-5178-1000
FAX : 86-21-5178-1008

KOYO AUSTRALIA PTY. LTD.

Unit 2, 8 Hill Road, Homebush Bay, NSW 2127, AUSTRALIA
TEL : 61-2-8719-5300
FAX : 61-2-8719-5333

JTEKT EUROPE BEARINGS B.V.

Markerkant 13-01, 1314 AL Almere, THE NETHERLANDS
TEL : 31-36-5383333
FAX : 31-36-5347212

-KOYO BENELUX BRANCH OFFICE-

Energieweg 10a, 2964LE, Groot-Ammers, P.O. Box 1, 2965ZG
Nieuwpoort, THE NETHERLANDS
TEL : 31-184606800
FAX : 31-184606857

-KOYO ROMANIA REPRESENTATIVE OFFICE-

Str. Dr. Lister nr. 24, ap. 1, sector 5, cod 050543, Bucharest,
ROMANIA
TEL : 40-21-410-4170/4182/0984
FAX : 40-21-410-1178

KOYO KULLAGER SCANDINAVIA A.B.

Johanneslundsvägen 4, 194 61 Upplands Väsby, SWEDEN
TEL : 46-8-594-212-10
FAX : 46-8-594-212-29

KOYO (U.K.) LIMITED

Whitehall Avenue, Kingston, Milton Keynes MK10 0AX,
UNITED KINGDOM
TEL : 44-1908-289300
FAX : 44-1908-289333

KOYO DEUTSCHLAND GMBH

Bargkoppelweg 4, D-22145 Hamburg, GERMANY
TEL : 49-40-67-9090-0
FAX : 49-40-67-9203-0

KOYO FRANCE S.A.

6 avenue du Marais, BP20189, 95105 Argenteuil, FRANCE
TEL : 33-1-3998-4202
FAX : 33-1-3998-4244/4249

KOYO IBERICA, S.L.

Avda.de la Industria, 52-2 izda 28820 Coslada Madrid, SPAIN
TEL : 34-91-329-0818
FAX : 34-91-747-1194

KOYO ITALIA S.R.L.

Via Stephenson 43/a 20157 Milano, ITALY
TEL : 39-02-2951-0844
FAX : 39-02-2951-0954

BEARING PLANTS

KOYO BEARINGS CANADA INC.

4 Victoria Street, Bedford, Quebec J0J-1A0, CANADA
TEL : 1-450-248-3316
FAX : 1-450-248-4196

KOYO CORPORATION OF U.S.A. (MANUFACTURING DIVISION)

-Orangeburg Plant-

2850 Magnolia Street, Orangeburg, SC 29115, U.S.A.
TEL : 1-803-536-6200
FAX : 1-803-534-0599

-Richland Plant-

1006 Northpoint Blvd., Blythewood, SC 29016, U.S.A.
TEL : 1-803-691-4624/4633
FAX : 1-803-691-4655

-Washington Plant-

146 Cutting Edge Court Telford, TN 37690, U.S.A.
TEL : 1-423-913-1006
FAX : 1-423-913-1008

KOYO BEARINGS USA LLC

-Dahlonega Plant-

615 Torrington Drive Dahlonega, GA 30533, U.S.A.
TEL : 1-706-864-7691
FAX : 1-706-864-8258

-Cairo Plant-

2525 Torrington Drive, PO BOX 2449, Cairo, GA 39828, U.S.A.
TEL : 1-229-377-6650
FAX : 1-229-377-9760

-Sylvania Plant-

400 Friendship Road, Sylvania, GA 30467, U.S.A.
TEL : 1-912-564-7151
FAX : 1-912-564-2101

-Walhalla Plant-

430 Torrington Road, Po Box 100, Walhalla, SC 29691, U.S.A.
TEL : 1-864-638-3683
FAX : 1-864-638-2434

JTEKT (THAILAND) CO., LTD.

172/1 Moo 12 Tambol Bangwua, Amphur Bangpakong,
Chachoengsao 24180, THAILAND
TEL : 66-38-830-571/578
FAX : 66-38-830-579

KOYO MANUFACTURING (PHILIPPINES) CORP.

Lima Technology Center, Municipality of Malvar, Batangas
Province 4233, PHILIPPINES
TEL : 63-43-981-0088
FAX : 63-43-981-0001

KOYO JICO KOREA CO., LTD.

28-12, Yulpo-Ri, Koduc-Myun, Pyung Teak-City, Kyungki-Do, KOREA
TEL : 82-31-668-6381
FAX : 82-31-668-6384

KOYO BEARING DALIAN CO., LTD.

No.II A-2 Dalian Export Processing Zone, Dalian City, Liaoning,
CHINA
TEL : 86-411-8731-0972/0974
FAX : 86-411-8731-0973

WUXI KOYO BEARING CO., LTD.

No.89 Dicu Road,Liyuan Economic Development Zone, Wuxi,
Jiangsu, CHINA
TEL : 86-510-85161901
FAX : 86-510-85161143

KOYO NEEDLE BEARINGS (WUXI) CO., LTD.

No.85 Dicu Road, Liyuan Economic Development Zone, Wuxi,
Jiangsu, 214072 P.R. CHINA
TEL : 86-51085160998
FAX : 86-51085163262

DALIAN KOYO WAZHOU AUTOMOBILE BEARING CO., LTD.

No.96, Liaohe East Road, Dalian, D.D Port, CHINA
TEL : 86-411-8740-7272
FAX : 86-411-8740-7373

KOYO LIOHO (FOSHAN) AUTOMOTIVE PARTS CO., LTD.

No.12, Wusha Section Of Shunpan Road, Daliang Town, Shunde
Of Foshan, Guangdong Province, CHINA
(SHUNDE INDUSTRIAL PARK)
TEL : 86-757-22829589
FAX : 86-757-22829586

KOYO AUTOMOTIVE PARTS (WUXI) CO.,LTD.

B6-A Wuxi National Hi-Tech Industrial Development Zone, Wuxi,
Jiangsu, CHINA
TEL : 86-510-8533-0909
FAX : 86-510-8533-0155

KOYO BEARINGS (EUROPE) LTD.

P.O.Box 101, Elmhirst Lane, Dodworth, Barnsley,
South Yorkshire S75 3TA, UNITED KINGDOM
TEL : 44-1226-733200
FAX : 44-1226-204029

KOYO ROMANIA S.A.

Tumu Magurele Street No.1, 140003, ALEXANDRIA Teleorman
County, ROMANIA
TEL : 40-247-306-400
FAX : 40-247-306-421

KOYO BEARINGS DEUTSCHLAND GMBH

Werkstrasse 5, D-33790 Halle (Westfalen), GERMANY
TEL : 49-5201-7070
FAX : 49-5201-707416

KOYO BEARINGS VIERZON MAROMME SAS

-Maromme Plant-

Zone Industrielle de LA-BP 1033, 7 Rue Ampere, Maromme,
76151, FRANCE
TEL : 33-23282-3838
FAX : 33-23576-6624

-Vierzon Plant-

61 Route de Foecy-BP 238, Vierzon Cedex, 18102 FRANCE
TEL : 33-24852-6200
FAX : 33-24852-6250

KOYO BEARINGS MOULT SAS

Zone Industrielle de Mout, 14370, FRANCE
TEL : 33-23127-9600
FAX : 33-23123-4693

KOYO BEARINGS ČESKÁ REPUBLIKA S.R.O.

Pavelkova 253/5, Bystrovany, Olomouc, 77900, CZECH REP
TEL : 42-585-126-501
FAX : 42-585-126-503

KOYO BEARINGS ESPAÑA S.A.

Doctor Diaz Empananza, 3, Bilbao, 48002, SPAIN
TEL : 34-94-4431400
FAX : 34-94-4440905

TECHNICAL CENTERS

JTEKT CORPORATION NORTH AMERICAN TECHNICAL CENTER

47771 Halyard Drive, Plymouth, MI 48170, U.S.A.
TEL : 1-734-454-1500
FAX : 1-734-454-4076

JTEKT RESEARCH AND DEVELOPMENT CENTER (WUXI) CO., LTD.

No.801 Hong Qiao Road, Li Yuan Economic Development Zone,
Wuxi Jiangsu 214072, CHINA
TEL : 86-510-8589-8613
FAX : 86-510-8589-8698

JTEKT CORPORATION EUROPEAN TECHNICAL CENTER

Markerkant 13-02, 1314 AL Almere, THE NETHERLANDS
TEL : 31-36-5383350
FAX : 31-36-5302656

KOYO BEARINGS USA LLC

GREENVILLE TECHNOLOGY CENTER

7 Research Drive, Greenville, SC 29607, U.S.A.
TEL : 1-864-770-2100
FAX : 1-864-770-2399

KOYO BEARINGS DEUTSCHLAND GMBH

KUENSEBECK TECHNOLOGY CENTER

Werkstrasse 5, D-33790 Halle (Westfalen), GERMANY
TEL : 49-5201-7070
FAX : 49-5201-707416

KOYO BEARINGS ČESKÁ REPUBLIKA S.R.O.

BRNO TECHNOLOGY CENTER

Technologicky Park Brno, Technicka 15, 61600 Brno, 61600
CZECH REP
TEL : 420-541-191803
FAX : 420-541-191801

Koyo® CERAMIC BEARINGS AND **EXSEV** BEARINGS

FOR EXTREME SPECIAL ENVIRONMENTS

Value & Technology



CAT. NO. B2004E-1
Printed in Japan '12.08-1CDS ('05.06)