

Miniature linear recirculating ball bearing and guideway assemblies

corrosion-resistant, two-row and four-row



Now with even more possibilities!

Linear bearings for the miniature applications sector require a different approach in the design of guidance systems. While normal criteria such as load capacity, rigidity and operating life are important, the additional factor of size also applies for miniature bearing arrangements. However, simply “scaling down” the standard sizes to smaller dimensions is not very successful in technical terms. INA has therefore developed its four-row miniature linear ball bearing and guideway assembly KUME..C. For applications requiring lower load carrying capacity, this high-performance guidance system is supplemented by a two-row unit.

Two-row linear ball bearing and guideway assemblies

These units have moderate load carrying capacity and moderate to high moment load capacity. Their modular design allows the interchange of guideways and carriages within the same interchangeability and accuracy class. This simplifies the fitting of guidance systems, allows easier sourcing of spare parts and gives highly economical stockholding.

The saddle plates and guideways are corrosion-resistant. Seals on the end faces of the carriages protect the rolling element system against contamination. The carriages are greased and can be relubricated. The guideways and carriages are also available in a wide version.

Four-row linear ball bearing and guideway assemblies

Four-row miniature linear ball bearing and guideway assemblies KUME..C are established, ready-to-fit guidance systems for unlimited stroke lengths. They have high load carrying capacity and rigidity. Due to the lubricant reservoir in the carriages, they are maintenance-free in many applications.

Applications

These guidance systems are particularly suitable for applications:

- in the microelectronics industry and related sectors
- in optical equipment
- in medical equipment
- in textile machinery
- that require high speeds and very uniform running
- where particularly economical miniature guidance systems are needed for moderate to high loads and moderate to high rigidity requirements.

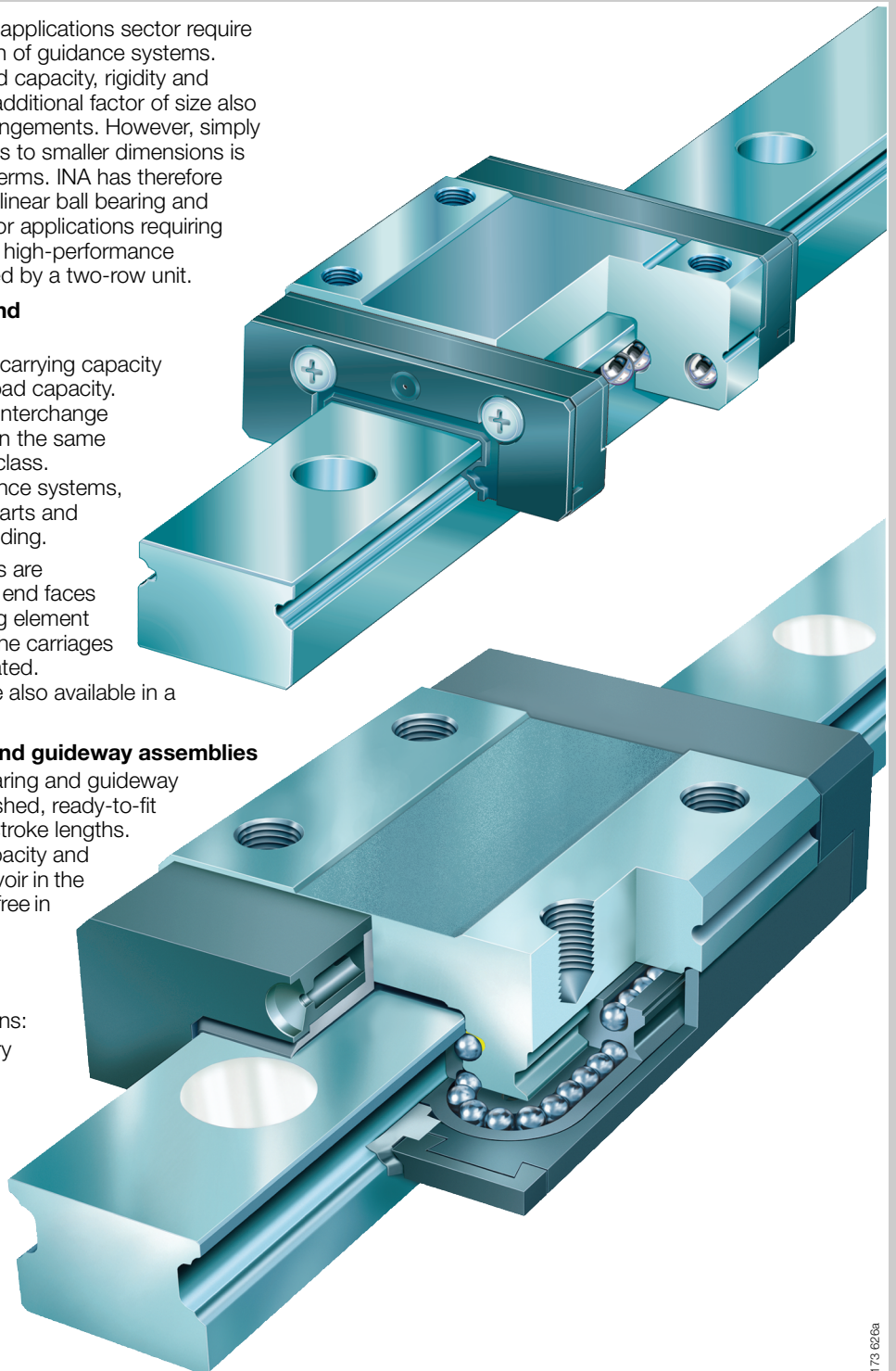

173 626a

Miniature linear recirculating ball bearing and guideway assemblies

corrosion-resistant, two-row and four-row

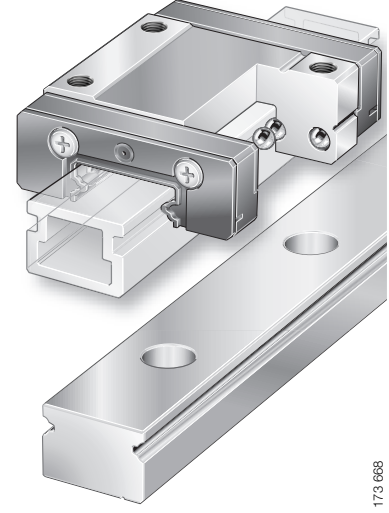
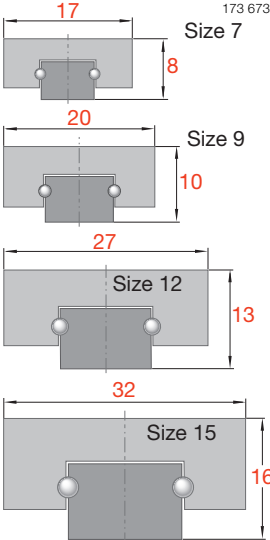
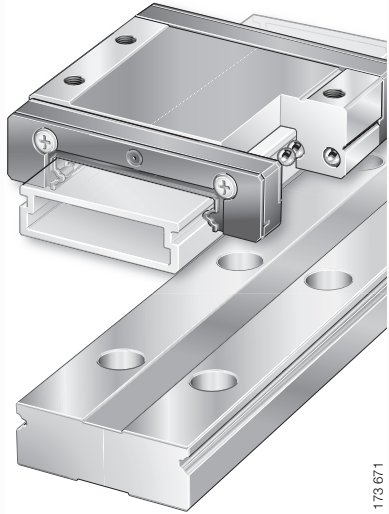
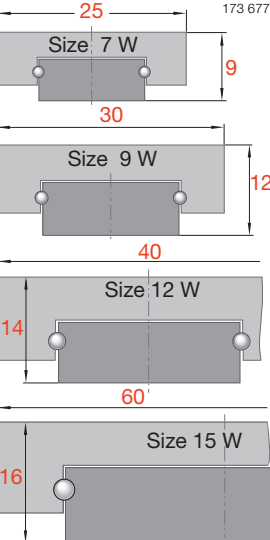
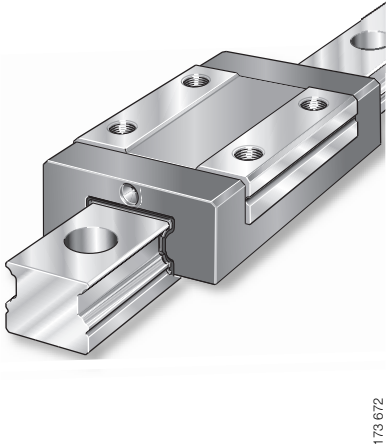
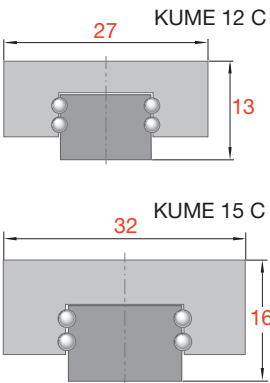
Feature	Characteristic	Dimensions/cross-section	Load carrying capacity and rigidity
<p>TKDM/KWEM</p>  <p>173 668</p>	<ul style="list-style-type: none"> linear locating bearing for unlimited stroke lengths consisting of guideway TKDM and carriage KWEM two-row, four point contact of rolling elements with raceways can support loads from all directions – apart from the direction of motion – and moments about all axes preloaded seals on end faces of carriage greased, can be lubricated with oil or grease 	<p>173 673</p>  <p>Size 7: 17 x 8</p> <p>Size 9: 20 x 10</p> <p>Size 12: 27 x 13</p> <p>Size 15: 32 x 16</p>	<p>moderate to high</p>
<p>TKDM..W/KWEM..W</p>  <p>173 671</p>	<ul style="list-style-type: none"> linear locating bearing for unlimited stroke lengths wide design consisting of guideway TKDM..W and carriage KWEM..W two-row, four point contact of rolling elements with raceways can support loads from all directions – apart from the direction of motion – and moments about all axes preloaded seals on end faces of carriage greased, can be lubricated with oil or grease 	<p>173 677</p>  <p>Size 7 W: 25 x 9</p> <p>Size 9 W: 30 x 12</p> <p>Size 12 W: 40 x 14</p> <p>Size 15 W: 60 x 16</p>	<p>moderate to high</p>
<p>KUME..C</p>  <p>173 672</p>	<ul style="list-style-type: none"> linear locating bearing for unlimited stroke lengths consisting of guideway and carriage four-row, two point contact of rolling elements with raceways can support loads from all directions – apart from the direction of motion – and moments about all axes preloaded with lubricant reservoir seals on end faces of carriage greased, can be lubricated with oil or grease 	<p>173 678</p>  <p>KUME 12 C: 27 x 13</p> <p>KUME 15 C: 32 x 16</p>	<p>high to very high</p>





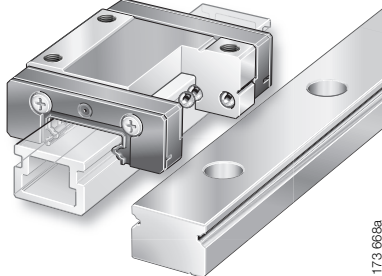
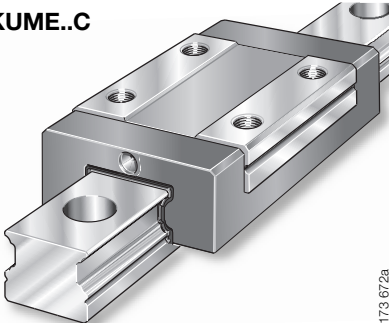
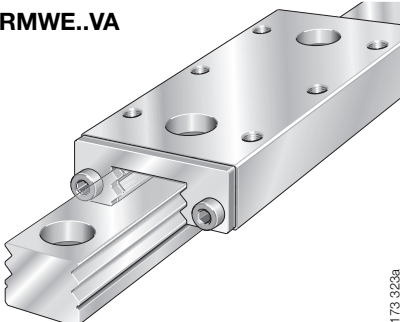
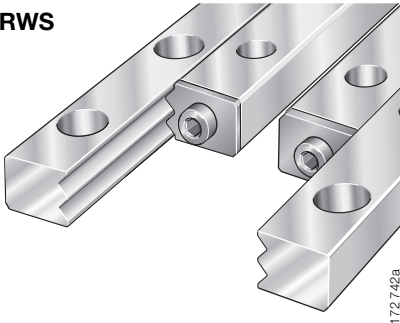
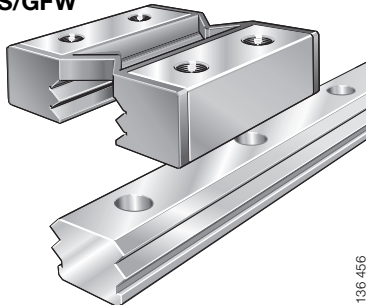

INA miniature linear guidance systems

Product range

Feature	Characteristic	Load carrying capacity	Rigidity	Information
Miniature linear guidance system				
TKDM..(W)/ KWEM..(W)  <small>173 688a</small>	<ul style="list-style-type: none"> ■ linear locating bearing for unlimited stroke lengths ■ consisting of guideway and carriage, not preassembled ■ two-row, four point contact of rolling elements with raceways ■ preloaded ■ seals on end faces of carriage ■ greased, can be lubricated with oil or grease ■ interchangeable 	moderate to high	moderate to high	MAI 81
KUME..C  <small>173 672a</small>	<ul style="list-style-type: none"> ■ linear locating bearing for unlimited stroke lengths ■ consisting of guideway and carriage ■ four-row, two point contact of rolling elements with raceways ■ preloaded ■ with lubricant reservoir ■ seals on end faces ■ can be lubricated with oil or grease 	high to very high	high to very high	MAI 81
RMWE..VA  <small>173 323a</small>	<ul style="list-style-type: none"> ■ linear locating bearing for limited stroke lengths ■ consisting of guideway and carriage, single or double row cylindrical roller flat cages, end pieces ■ cylindrical rollers in O or X arrangement ■ higher load carrying capacity and rigidity than recirculating guidance systems in comparable design envelope ■ very smooth running and high running accuracy ■ preloaded ■ greased, can be lubricated with oil or grease 	very high	very high	MAI 77
RWS  <small>172 742a</small>	<ul style="list-style-type: none"> ■ linear locating bearing for limited stroke lengths ■ consisting of guideways, cylindrical roller flat cages, end pieces ■ cylindrical rollers in O or X arrangement ■ higher load carrying capacity and rigidity than recirculating guidance systems in comparable design envelope ■ spacing between guidance systems can be selected ■ are preloaded ■ can be lubricated with oil or grease 	very high	very high	MAI 79
GFS/GFW  <small>136 456</small>	<ul style="list-style-type: none"> ■ linear locating bearing for stroke lengths up to 3 m ■ maintenance-free ■ consisting of guideway and carriage with plain sliding layer ■ highly suitable for light metal constructions ■ wear-resistant ■ insensitive to contamination ■ adjustable clearance ■ interchangeable as required 	low	low	MAI 78

Two-row miniature linear recirculating ball bearing and guideway assemblies

corrosion-resistant

	Design and safety guidelines.....	6
	Preload	7
	Accuracy.....	8
	Demands on the adjacent construction	10
	Accessories	12
	Ordering example and ordering designation	13



Features

Two-row miniature linear recirculating ball bearing and guideway assemblies

- of this series consist of:
 - at least one narrow or wide carriage made from corrosion-resistant rolling bearing steel with a full complement ball system and one locating face
 - ball retainers in the carriages
 - a narrow or wide guideway made from corrosion-resistant rolling bearing steel with two locating edges
 - the carriage is not supplied mounted on the guideway. There is a plastic dummy guideway in the carriage
- have 2 rows of rolling elements in four point contact with the raceways
- are linear locating bearings
- can support loads from all directions – apart from the direction of motion – and moments about all axes
- are preloaded
- have seals on the end faces of the carriages to seal off the rolling element system
- are designed according to a modular concept. Within the same size and preload class, guideways can be combined with all carriage types (type W guideways can only be combined with type W carriages)
- are greased, but can also be supplied ungreased
- are lubricated via lubrication holes in the end piece of the carriage
 - lubrication nipple included with size 15
- are suitable for:
 - accelerations up to 50 m/s^2
 - speeds up to 180 m/min
 - operating temperatures from $-40 \text{ }^\circ\text{C}$ to $+100 \text{ }^\circ\text{C}$

Carriage – corrosion-resistant

**KWEM
KWEM..W**

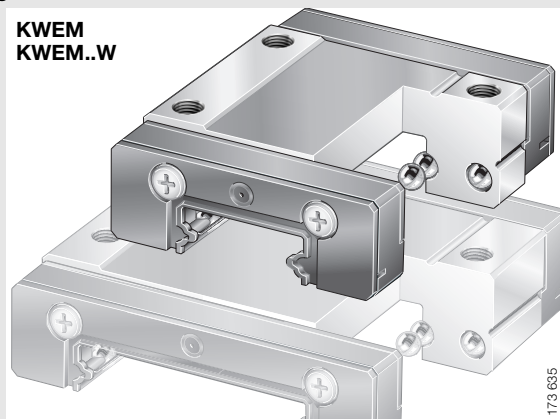

173 635

- saddle plate made from corrosion-resistant, hardened steel, rolling element raceways precision ground
 - balls are recirculated in enclosed channels with plastic return elements
- end pieces with gap seals and lubrication holes
 - lubrication nipple supplied with size 15
- KWEM..W: wide carriage



Guideway – corrosion-resistant

**TKDM
TKDM..W**

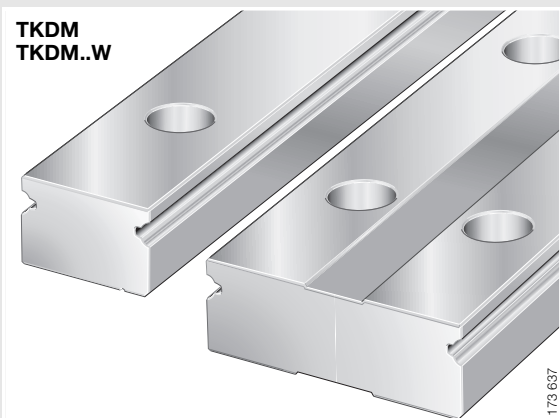

173 637

- corrosion-resistant steel, hardened and ground on all faces, rolling element raceways precision ground
- located from above
- one or two rows of holes for fixing screws
 - though holes with counterbores
- TKDM..W: wide guideway



Two-row miniature linear recirculating ball bearing and guideway assemblies – corrosion-resistant

KWEM..(W)/TKDM..(W)

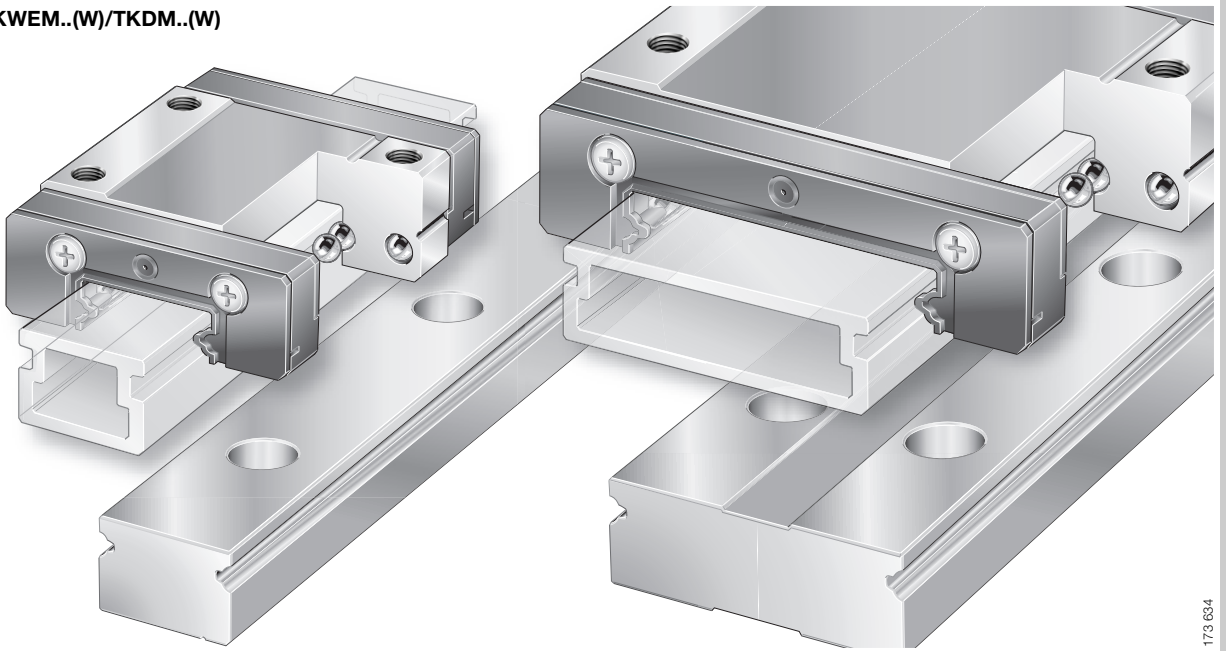

173 634



16-19

Accessories

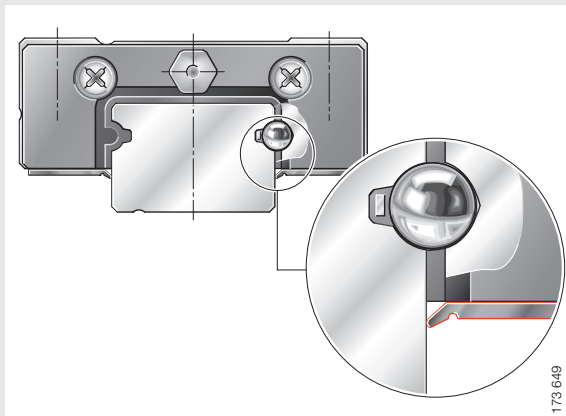

173 649

■ sealing strips for carriages

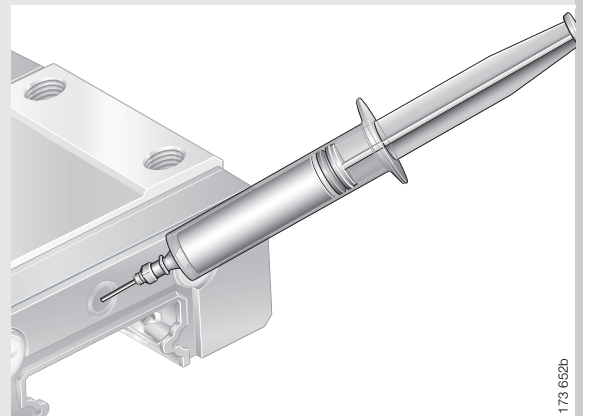

173 652b

■ grease injector for greasing of carriages



12



12

Two-row miniature linear recirculating ball bearing and guideway assemblies

corrosion-resistant



Design and safety guidelines

Load carrying capacity and life

The size of the guidance unit is determined by the load carrying capacity of the individual elements. The load carrying capacity is described in terms of the basic dynamic load rating C and basic static load rating C_0 (*dimension table*).

Basic rating life

The basic rating life is determined as follows:

$$L = \left(\frac{C}{P}\right)^p$$

$$L_h = \frac{8,33 \cdot 10^5}{H \cdot n_{osc}} \cdot \left(\frac{C}{P}\right)^p$$

Static load safety factor

The static load safety factor S_0 indicates the security with regard to permissible permanent deformation in the bearing without affecting the guidance accuracy and smooth running of the bearing.

It can be determined using the following formula:

$$S_0 = \frac{C_0}{P_0}$$

$$S_0 = \frac{M_0}{M}$$



If high demands are placed on accuracy and smoothness of running, the static load safety factor should not be less than $S_0 = 3$.

For high loads, the load carrying capacity of the fixing screws must be checked (see VDI Guideline 2 230).

The equivalent static bearing load is determined by the maximum load F_{max} .

$$P_0 = F_{max}$$

$$M_0 = M_{max}$$

C N
Basic dynamic load rating (*dimension table*)

C_0 N
Basic static load rating (*dimension table*)

H mm
Distance between ends of stroke

L mm
Basic rating life in 100 000 m

L_h h
Basic rating life in operating hours

M Nm
Equivalent static moment in load direction

M_0 Nm
Basic static moment rating in load direction (M_{0x} , M_{0y} , M_{0z} from *dimension table*)

n_{osc} min⁻¹
Number of return strokes per minute

p –
Life exponent $p = 3$

P N
Equivalent dynamic load

P_0 N
Maximum equivalent static load

S_0 –
Static load safety factor.

Conversion

Basic load ratings to DIN, basic load ratings as used in the Far East

Ball monorail guidance systems

$$C_{50000} = 1,26 \cdot C_{DIN}$$

$$C_{DIN} = 0,79 \cdot C_{50000}$$

C_{DIN} N
Basic dynamic load rating C for distance of 100 000 m – definition to DIN 636

C_{50000} N
Basic dynamic load rating C for distance of 50 000 m.

Interchangeability

The guideways and carriages can be used in any combination within the same accuracy and interchangeability class.

This has the following benefits:

- economical stockholding
- simple spare parts sourcing
- straightforward installation.

The preload class is determined by the carriage.

Delivered condition

The carriage ① and guideway ③ are not supplied preassembled (Figure 1).

There is a plastic dummy guideway ② in the carriage.

This guideway prevents damage to the rolling element set while the carriage is separate from the guideway.

The carriages are greased.

Corrosion-resistant design



The miniature linear recirculating ball bearing and guideway assemblies are corrosion-resistant due to the steels used in the manufacture of the saddle plates and guideways.

If very high levels of corrosion resistance are required, however, the suitability of the unit for the specific application must be investigated.



Preload

Miniature linear recirculating ball bearing and guideway assemblies KUEM (W) are available in the preload classes according to Table 1.

Increasing the preload has the effect of increasing:

- the rigidity
- the moment load carrying capacity
- the guidance accuracy.

However, preload also influences the displacement resistance and the operating life of recirculating guidance systems.

Table 1 · Preload

Preload class	Preload setting
V0 (standard)	zero to light preload
V1	preload

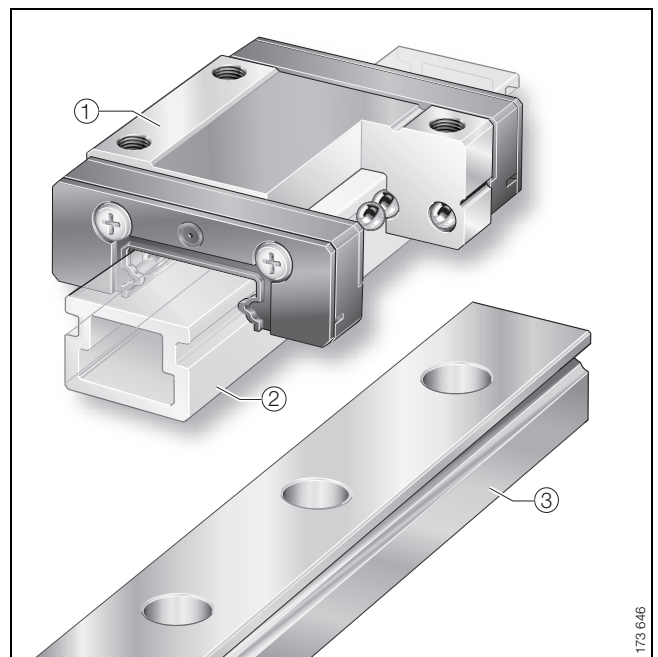

Figure 1 · Scope of delivery – guideway, carriage and dummy guideway

173 646

Two-row miniature linear recirculating ball bearing and guideway assemblies

corrosion-resistant



Accuracy

Two-row linear recirculating ball bearing and guideway assemblies are available in accuracy classes G1 and G2 (Figure 2).

For accuracy class tolerances, see Table 2 and Figure 2, for reference dimensions see Figure 3.

The tolerances are arithmetic mean values (Figure 2 and Table 2). They relate to the centre point of the screw mounting or locating surfaces of the carriage. The dimensions H and A₁ should always remain within the tolerance irrespective of the position of the carriage on the guideway.

Table 2 · Accuracy classes and tolerances

Tolerance	Accuracy class	Accuracy class	
		G1 μm	G2 μm
for height	H	± 10	± 20
Height difference ¹⁾	ΔH	7	15
for distance	A ₁	± 15	± 25
Distance difference ¹⁾	ΔA ₁	10	20

¹⁾ Dimensional difference between several carriages on one guideway, measured at the same point on the guideway.

Parallelism of raceways to locating surfaces

Parallelism tolerances of guideways: see Figure 2.

Tolerances of guideways

Tolerances: see Figure 4 and Table 3.

Table 3 · Length tolerances

Guideway Designation	Tolerances of guideways
TKDM 7	+0,2 / -2,2
TKDM 7 W	+0,25 / -2,25
TKDM 9	
TKDM 9 W	
TKDM 12	
TKDM 12 W	+0,3 / -2,3
TKDM 15	+0,25 / -2,25
TKDM 15 W	+0,3 / -2,3

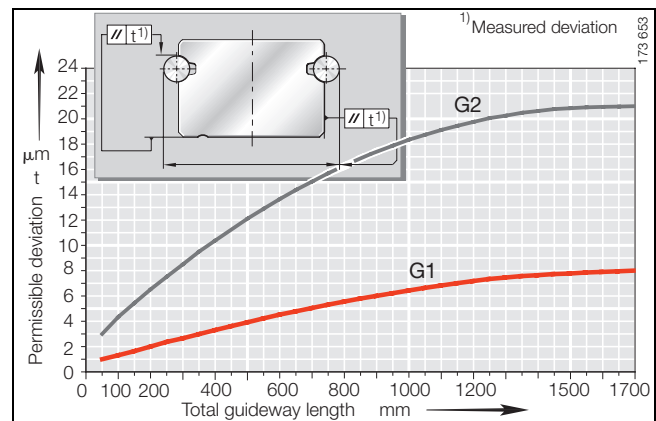

Figure 2 · Accuracy classes and parallelism tolerances of guideways

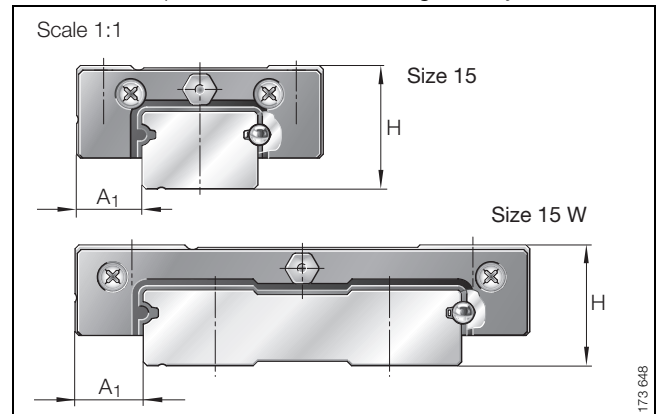

Figure 3 · Reference dimensions for accuracy

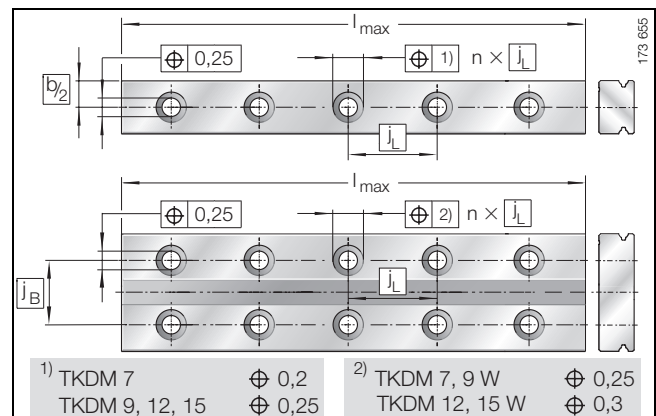

Figure 4 · Positional and length tolerances of guideways – hole pattern to ISO 1101

Hole patterns of guideways

The guideways have a symmetrical hole pattern (Figure 5 and Figure 6). For an asymmetrical hole pattern (customer request), the following must apply:

- $a_L \geq a_{L\min}$ and $a_R \geq a_{R\min}$ (Figure 5, Figure 6).

Maximum number of pitches between holes

The number of pitches between holes is the rounded whole number equivalent to:

$$n = \frac{l_{\max} - (2 \cdot a_{L\min})}{j_L}$$

The distances a_L and a_R are generally determined by:

$$a_L + a_R = l_{\max} - n \cdot j_L$$

For guideways with a symmetrical hole pattern:

$$a_L = a_R = \frac{1}{2} \cdot (l_{\max} - n \cdot j_L)$$

Number of holes:

$$x = n + 1$$

a_L, a_R mm
Distance between start or end of guideway and nearest hole

$a_{L\min}, a_{R\min}$ mm
Minimum values for a_L, a_R according to *Dimension table*

l_{\max} mm
Guideway length

n -
Maximum number of pitches between holes

j_L mm
Distance between holes

x -
Number of holes.

⚠ The minimum and maximum values for $a_{L\min}$ and $a_{R\min}$ must be observed, otherwise the counterbores may be intersected by the end of the guideway.

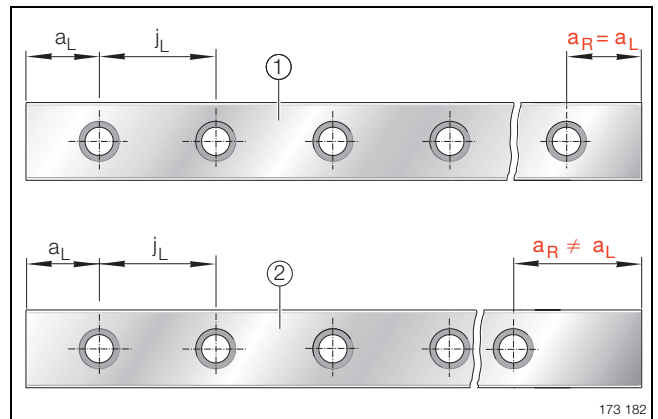

Figure 5 · Symmetrical ① and asymmetrical ② hole patterns for guideways with one row of holes

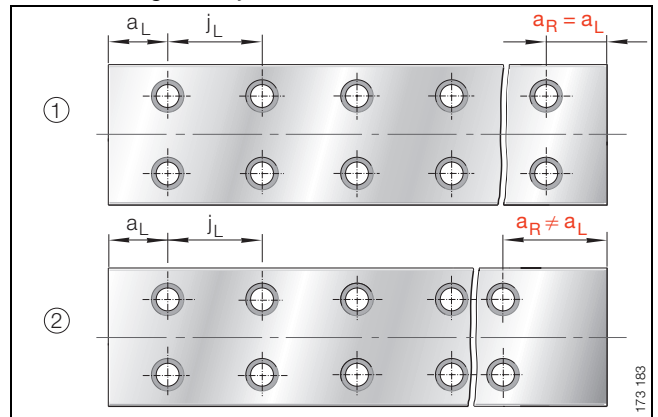

Figure 6 · Symmetrical ① and asymmetrical ② hole patterns for guideways with two rows of holes

Two-row miniature linear recirculating ball bearing and guideway assemblies

corrosion-resistant



Demands on the adjacent construction

The design of the bearing arrangement is essentially determined by the requirements for accuracy, rigidity and load carrying capacity of the bearing arrangement. This has a direct influence on the adjacent construction and primarily concerns:

- the geometrical and positional accuracy of the mounting surfaces
- the location of the guidance elements.

! Ensure that the adjacent construction has adequate strength.

Geometrical and positional accuracy of the mounting surfaces

Observe the tolerances for the support and locating surfaces in accordance with Figure 7, Figure 8 and Table 5. Surfaces should be ground or precision milled. A mean roughness value of $R_a 1,6$ should be achieved.

- !** If these tolerances are not met:
- this will impair the overall accuracy of the guidance system
 - the preload will be affected
 - the operating life of the guidance system will be reduced.

For ΔH (Figure 7, Figure 8), deviations are permissible in accordance with the following formula. If the deviation is greater than this, please consult INA.

$$\Delta H = a \cdot b$$

ΔH μm
Maximum permissible deviation from the theoretically precise position

a -
Factor, dependent on the size and preload class V0, V1 (Table 4).
Guidance system clearance-free.

b mm
Centre distance between guidance elements.

Table 4 · Factor – dependent on size and preload class

Guideway/carriage Designation	Factor a	
	V0	V1
TKDM 7 (W) / KWEM 7 (W)	0,125	0,02
TKDM 9 (W) / KWEM 9 (W)	0,175	0,03
TKDM 12 (W) / KWEM 12 (W)	0,25	0,06
TKDM 15 (W) / KWEM 15 (W)	0,3	0,15

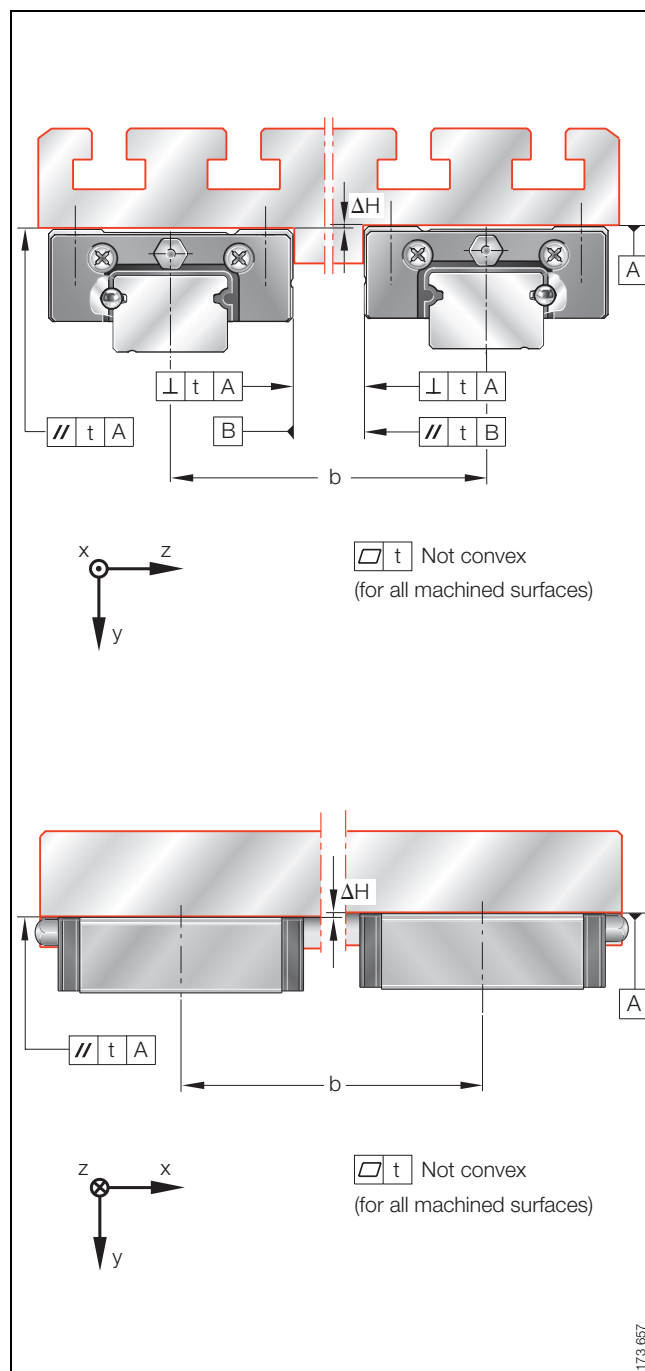

Figure 7 · Tolerances for mounting surfaces

Parallelism of mounted guideways

For guideways arranged parallel to each other, the parallelism value t given in Figure 8 and Table 5 should be adhered to. If the maximum values are used, this may increase the displacement resistance. If larger tolerances are present, please consult INA.

For calculation of ΔH , see page 10.

Table 5 · Values for t

Guideway Designation	t μm	
	G2	G1
TKDM 7 (W)	30	20
TKDM 9 (W)		
TKDM 12 (W)		
TKDM 15 (W)		

Locating heights and corner radii

Locating heights and corner radii should be in accordance with Figure 9 and Table 6.

Table 6 · Locating heights and corner radii

Guideway/carriage Designation	Locating heights and corner radii			
	h_1	$h_2 \text{ max}$	$r_1 \text{ max}$	$r_2 \text{ max}$
TKDM 7 (W) / KWEM 7 (W)	2,5	1,2	0,2 ¹⁾	0,2 ¹⁾
TKDM 9 (W) / KWEM 9 (W)	3	1,5	0,2 ¹⁾	0,2 ¹⁾
TKDM 12 (W) / KWEM 12 (W)	4	2,5	0,4	0,4
TKDM 15 (W) / KWEM 15 (W)	4,5	3	0,7	0,4

¹⁾ Preferably with undercut.

Sealing

In order to prevent damage to the guidance systems, the raceways must be kept clean at all times. If the end pieces used as standard are not adequate for this purpose, additional seals must be provided in the adjacent construction.

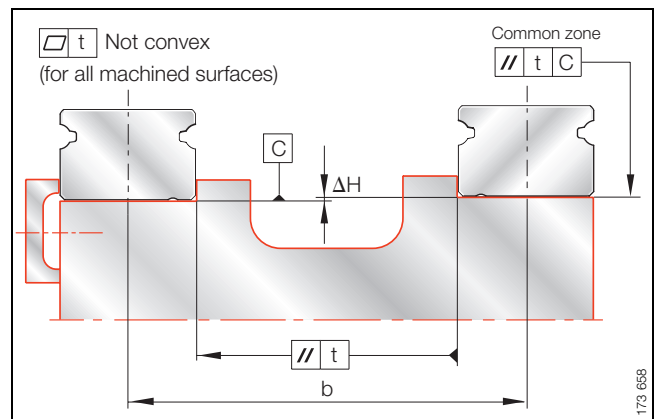

Figure 8 · Parallelism of mounted guideways

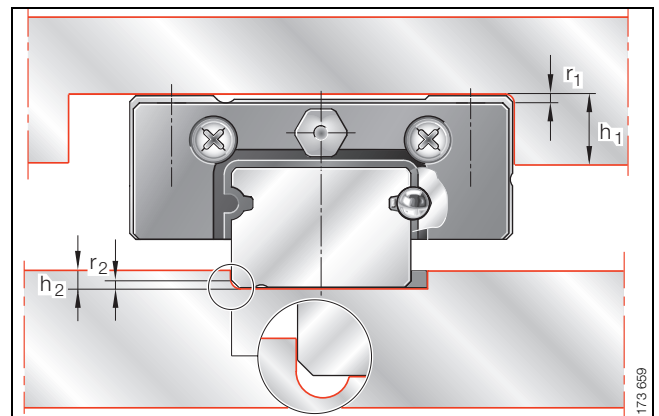

Figure 9 · Locating heights and corner radii

Two-row miniature linear recirculating ball bearing and guideway assemblies

corrosion-resistant



Accessories

Sealing strips

For applications in contaminated environments, the carriages can be fitted with sealing strips ①. In this case, the reduced dimension H_1 must be taken into consideration (Figure 10 and Table 7).

Suffix for carriages with sealing strips:

- suffix LD.

Table 7 · Dimension H_1 for fitted sealing strips

Guideway/carriage Designation	H_1
TKDM 9 / KWEM 9	1
TKDM 9 W / KWEM 9 W	2
TKDM 12 / KWEM 12	2
TKDM 12 W / KWEM 12 W	2
TKDM 15 / KWEM 15	3
TKDM 15 W / KWEM 15 W	3

Greasing

Carriages KWEM (W) can also be supplied without greasing:

- suffix UG.

For “clean room” applications, carriages with special grease are available. Please consult INA in this case.

A miniature grease injector is available for carriages with a lubrication hole (Figure 11). This can be supplied with:

- standard grease
 - ordering designation SPRI-KWEM
- “clean room” grease. Please consult INA in this case.

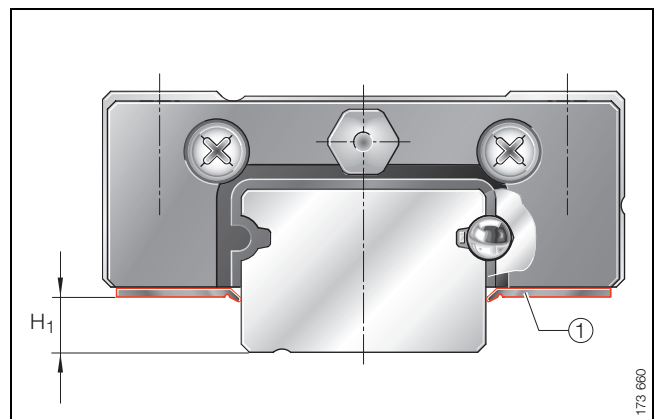

Figure 10 · Dimension H_1

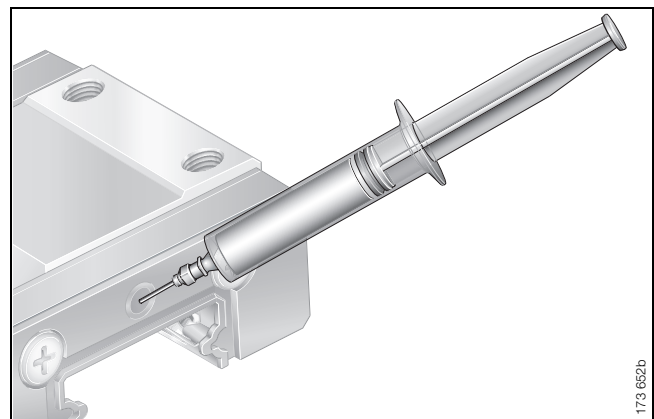

Figure 11 · Grease injector



Ordering example and ordering designation

Example 1:

Symmetrical hole pattern

Accuracy G1, with preload, with sealing strips

Number of carriages	2
Carriage	KWEM
Size	9
With sealing strips	LD
Accuracy of guidance system	G1
Preload class	V1

Number of guideways	1
Guideway	TKDM
Size	9
Accuracy	G1
Guideway length	220 mm

Ordering designation:

2 off KWEM 9 LD G1 V1

1 off TKDM 9 G1/220 (Figure 12).

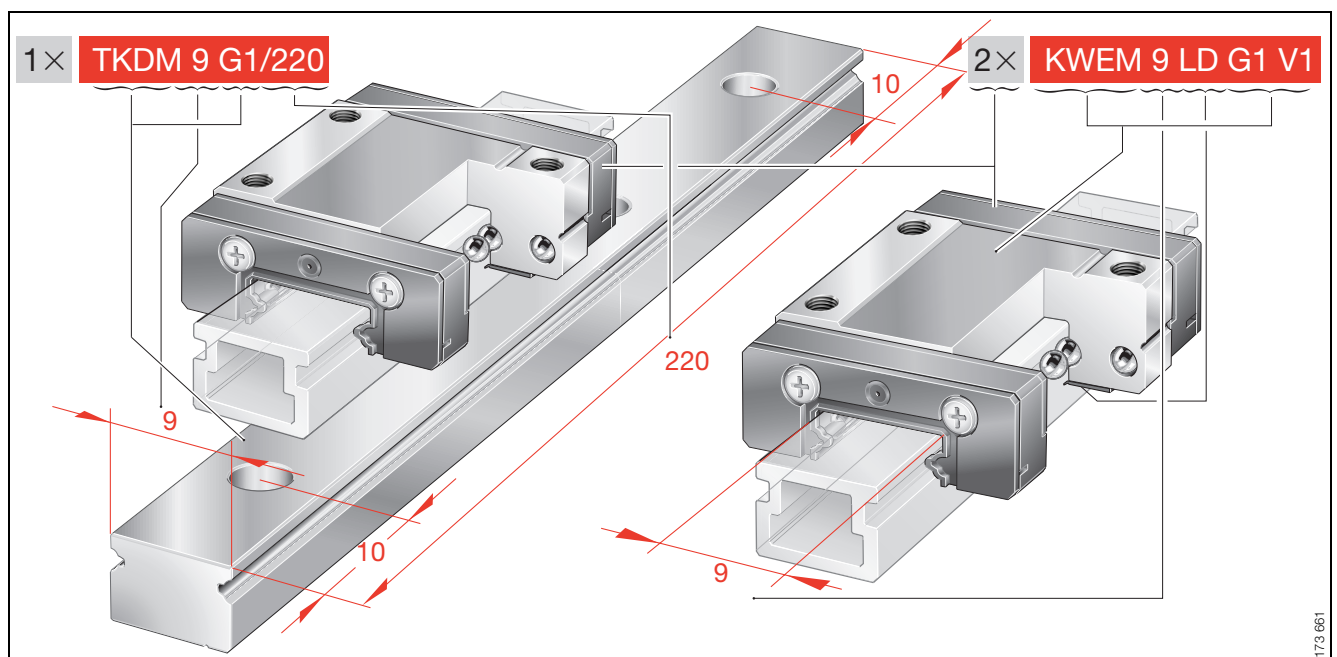

Figure 12 · Ordering example, ordering designation

Two-row miniature linear recirculating ball bearing and guideway assemblies

corrosion-resistant



Ordering example and ordering designation

Example 2:

Symmetrical hole pattern

Accuracy G2, without preload, wide version, ungreased

Number of carriages 4

Carriage KWEM

Size 15

Wide design W

Accuracy of guidance system G2

Preload class V0

Ungreased UG

Number of guideways 2

Guideway TKDM

Size 15

Wide design W

Accuracy G2

Guideway length 240 mm

Ordering designation:

4 off KWEM 15 W G2 V0 UG

2 off TKDM 15 W G2/240 (Figure 13).

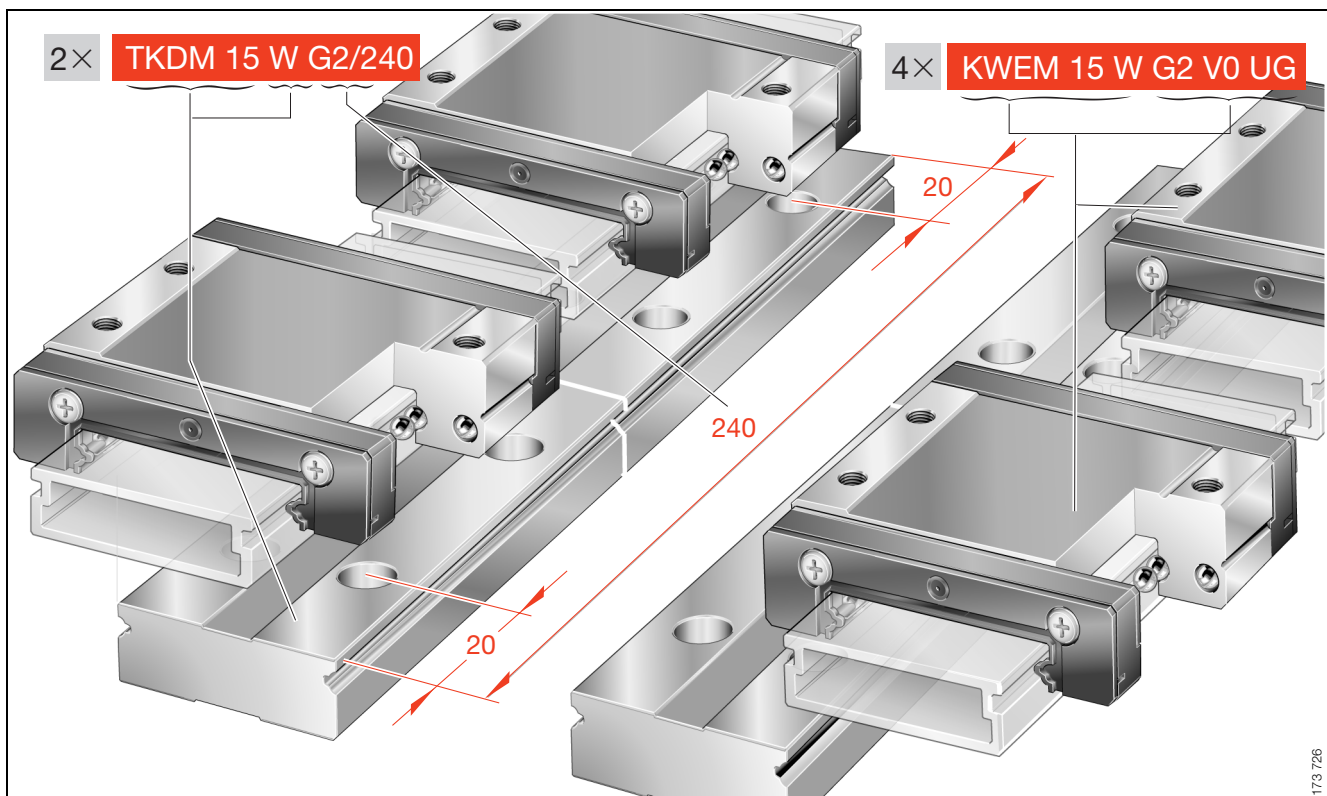

Figure 13 · Ordering example, ordering designation

Two-row miniature linear recirculating ball bearing and guideway assemblies

corrosion-resistant

Series KWEM/TKDM

Dimension table · Dimensions in mm												
Carriage		Guideway		Dimensions				Mounting dimensions				
Designation	Mass m ≈kg	Designation	Mass m ≈kg/m	$l_{max}^{1)}$	H	B	L	A_1	J_B	b	A_2	L_1
KWEM 7	0,01	TKDM 7	0,07	300	8	17	23,5	5	12	7	2,5	14,3
KWEM 9	0,019	TKDM 9	0,3	860	10	20	30	5,5	15	9	2,5	20,8
KWEM 12	0,035	TKDM 12	0,65	1000	13	27	34	7,5	20	12	3,5	21,6
KWEM 15	0,064	TKDM 15	1,07	1000	16	32	42	8,5	25	15	3,5	27,8

1) Maximum length l_{max} of guideways; longer guideways by agreement.
Available standard lengths: see page 17.

2) If there is a possibility of settling, the fixing screws should be secured against rotation.

3) A lubrication nipple is included with size 15.

Thread, screw and tightening torques²⁾

Carriage			Guideway		
Designation	G_2 for screw ISO 4 762-12.9		Designation	K_1 for screw ISO 4 762-12.9	
		Nm max.			Nm max.
KWEM 7	M2	0,6	TKDM 7	M2	0,6
KWEM 9	M3	2,2	TKDM 9	M3	2,2
KWEM 12	M3	2,2	TKDM 12	M3	2,2
KWEM 15	M3	2,2	TKDM 15	M3	2,2

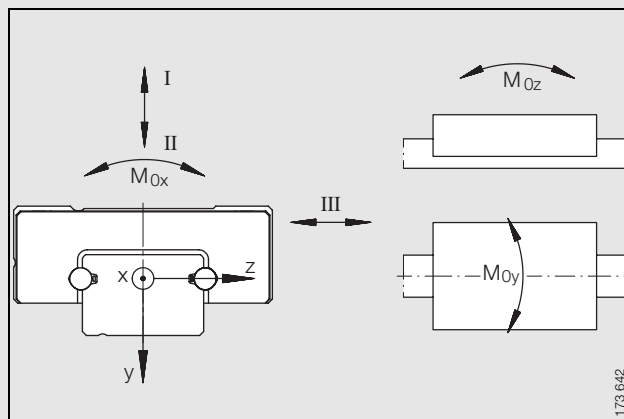

Load directions

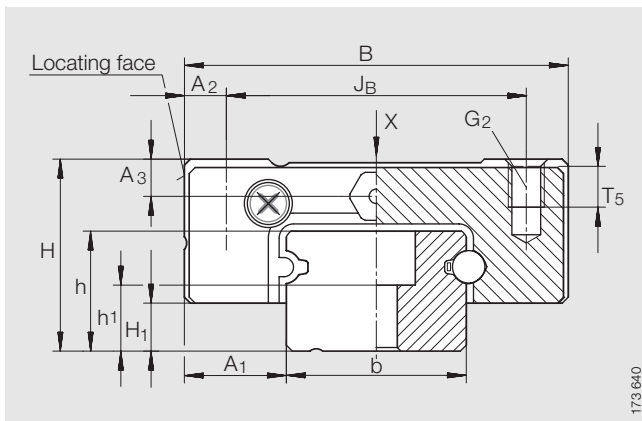

KWEM with TKDM

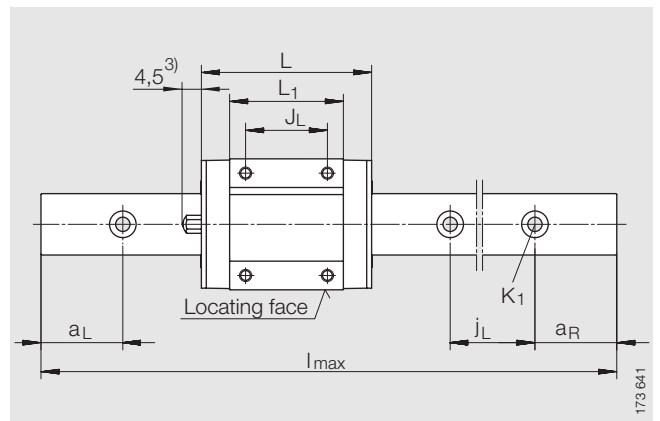

KWEM with TKDM · View X (rotated 90°)

											Load carrying capacity						
J _L	j _L	a _{Lmin}	a _{Lmax}	a _{Rmin}	a _{Rmax}	H ₁	T ₅	A ₃	h	h ₁	Basic load ratings				Moment ratings		
											Load directions I and II Tensile and compressive load		Load directions III Lateral load				
											C N	C ₀ N	C N	C ₀ N	M _{0x} Nm	M _{0y} Nm	M _{0z} Nm
8	15	4,5	12	4,5	12	1,5	2,5	1,5	5	2,7	950	1960	850	1650	7,2	4,1	4,9
10	20	4,5	14,5	4,5	14,5	2	3	2,2	6	2,5	1270	2860	1100	2400	13,3	7,9	9,4
15	25	5	17,5	5	17,5	3	3,5	2,7	8	3,5	2340	4450	2050	3700	27,6	13,4	16
20	40	5,5	25,5	5,5	25,5	4	4	3,1	10	5,5	3450	6730	3000	5700	51,8	25,9	30,8

Standard lengths for guideways¹⁾

TKDM 7		TKDM 9		TKDM 12		TKDM 15	
Lengths	Mass kg	Lengths	Mass kg	Lengths	Mass kg	Lengths	Mass kg
60	0,013	60	0,02	100	0,07	160	0,17
90	0,02	80	0,03	150	0,1	240	0,26
120	0,026	120	0,04	200	0,13	320	0,34
150	0,033	160	0,06	275	0,18	440	0,47
180	0,04	220	0,08	350	0,2	560	0,6
240	0,053	280	0,1	475	0,3	680	0,73
300	0,07	860	0,3	1000	0,7	1000	1,07

Two-row miniature linear recirculating ball bearing and guideway assemblies

corrosion-resistant

Series KWEM..W/TKDM..W

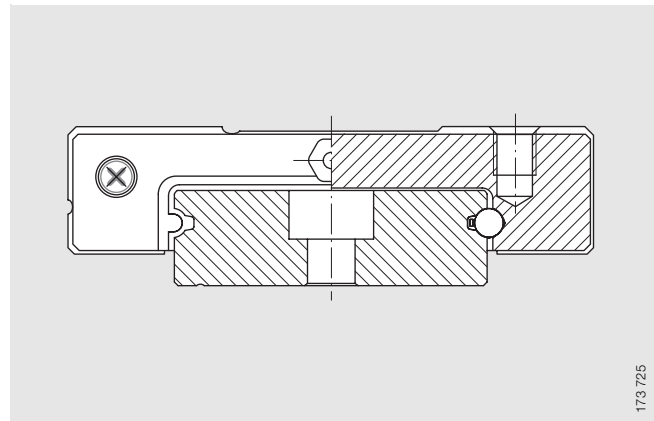

TKDM 7 W, 9 W and 12 W

Dimension table · Dimensions in mm

Carriage		Guideway		Dimensions				Mounting dimensions				
Designation	Mass m ≈kg	Designation	Mass m ≈kg/m	$l_{max}^{1)}$	H	B	L	A_1	J_B	j_B	b	A_2
KWEM 7 W	0,021	TKDM 7 W	0,54	300	9	25	31,5	5,5	19	–	14	3
KWEM 9 W	0,044	TKDM 9 W	0,9	690	12	30	39	6	21	–	18	4,5
KWEM 12 W	0,076	TKDM 12 W	1,39	680	14	40	44	8	28	–	24	6
KWEM 15 W	0,14	TKDM 15 W	2,94	680	16	60	55	9	45	23	42	7,5

1) Maximum length l_{max} of guideways; longer guideways by agreement.
Available standard lengths: see page 19.

2) If there is a possibility of settling, the fixing screws should be secured against rotation.

3) A lubrication nipple is included with size 15.

Thread, screw and tightening torques²⁾

Carriage			Guideway		
Designation	G_2 for screw ISO 4 762-12.9		Designation	K_1 for screw ISO 4 762-12.9	
		Nm max.			Nm max.
KWEM 7 W	M3	2,2	TKDM 7 W	M3	2,2
KWEM 9 W	M3	2,2	TKDM 9 W	M3	2,2
KWEM 12 W	M3	2,2	TKDM 12 W	M4	5
KWEM 15 W	M4	5	TKDM 15 W	M4	5

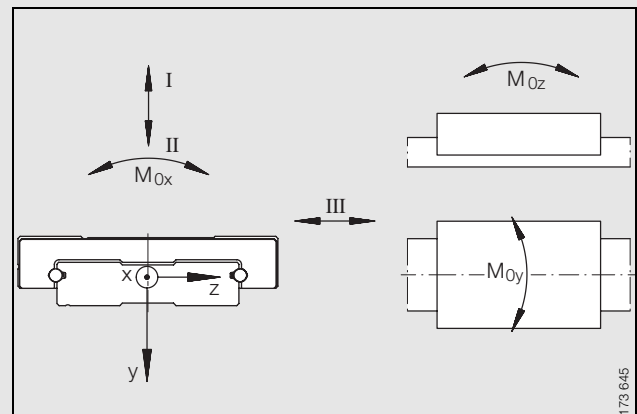

Load directions

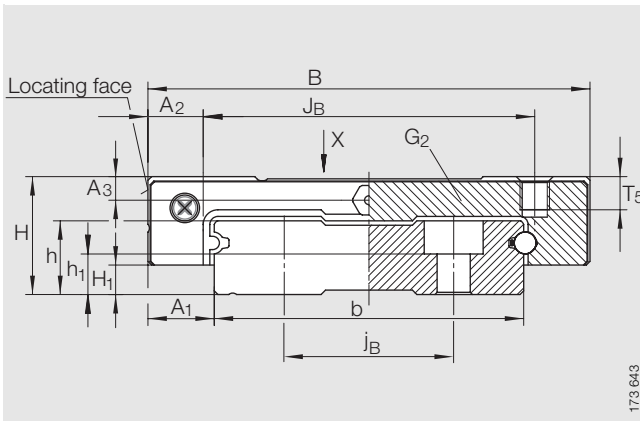

KWEM 15 W with TKDM 15 W

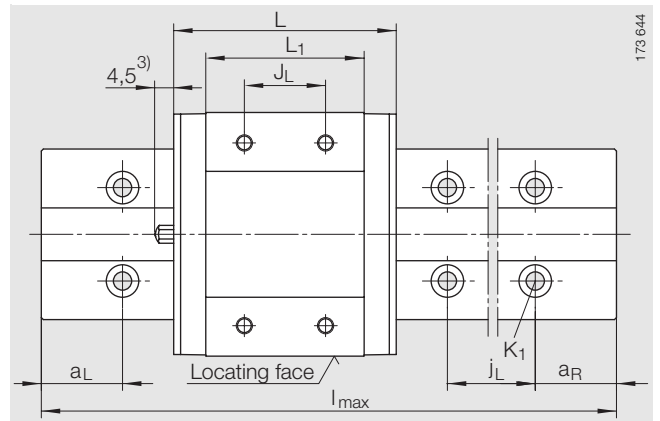

KWEM 15 W with TKDM 15 W · View X (rotated 90°)







												Load carrying capacity						
L ₁	J _L	j _L	a _{Lmin}	a _{Lmax}	a _{Rmin}	a _{Rmax}	H ₁	T ₅	A ₃	h	h ₁	Basic load ratings				Moment ratings		
												Load directions I and II Tensile and compressive load		Load directions III Lateral load				
												C	C ₀	C	C ₀	M _{0x}	M _{0y}	M _{0z}
N	N	N	N	Nm	Nm	Nm												
22	10	30	5,5	20,5	5,5	20,5	2	3	1,7	5,5	2,3	1250	2940	1100	2450	21	8,7	10,4
28,6	12	30	5,5	20,5	5,5	20,5	3	3	2,5	7	2,5	1590	3960	1400	3300	36,2	14,7	17,5
31	15	40	6,5	26,5	6,5	26,5	3	3,5	3,2	8	3,5	3000	6430	2600	5400	78,4	26,7	31,8
39	20	40	6,5	26,5	6,5	26,5	4	4,5	3,2	10	5,5	4850	10200	4300	8600	216	53,3	63,6

Standard lengths for guideways¹⁾

TKDM 7 W		TKDM 9 W		TKDM 12 W		TKDM 15 W	
Lengths	Mass kg	Lengths	Mass kg	Lengths	Mass kg	Lengths	Mass kg
90	0,049	90	0,08	120	0,17	160	0,47
120	0,065	120	0,11	160	0,22	240	0,71
150	0,08	150	0,14	240	0,33	320	0,94
180	0,097	180	0,16	320	0,45	440	1,29
240	0,13	240	0,22	400	0,56	560	1,65
300	0,16	300	0,27	480	0,67	680	1,99
-	-	690	0,62	680	0,95	-	-

Four-row miniature linear recirculating ball bearing and guideway assemblies

corrosion-resistant

	Page
 Design and safety guidelines.....	22
 Preload	23
 Accuracy.....	24
 Demands on the adjacent construction	26
 Accessories	28
 Ordering example and ordering designation	28



Features

Four-row miniature linear recirculating ball bearing and guideway assemblies

- of these series are complete units comprising:
 - at least one carriage made from corrosion-resistant rolling bearing steel with a full complement ball system and one locating face
 - ball retainers in the carriages
 - a guideway made from corrosion-resistant rolling bearing steel with two locating edges
 - plastic closing plugs for closing off the counterbores in the guideways
- have 4 rows of rolling elements that are in two point contact with the raceways and support forces at a contact angle of 45°
- are linear locating bearings
- can support loads from all directions – apart from the direction of motion – and moments about all axes
- are preloaded
- have seals on the end faces of the carriages to seal off the rolling element system
- have a lubricant reservoir in the carriage. As a result, they are maintenance-free for most applications
- are not greased
- are lubricated via lubrication holes in the end piece of the carriage
 - a lubrication nipple is fitted in the end piece of size 15
- are supplied preassembled
 - there is at least one carriage on one guideway
- are suitable for:
 - accelerations up to 40 m/s²
 - speeds up to 180 m/min
 - operating temperatures from –40 °C to +100 °C.

Carriage – corrosion-resistant

KWME..C

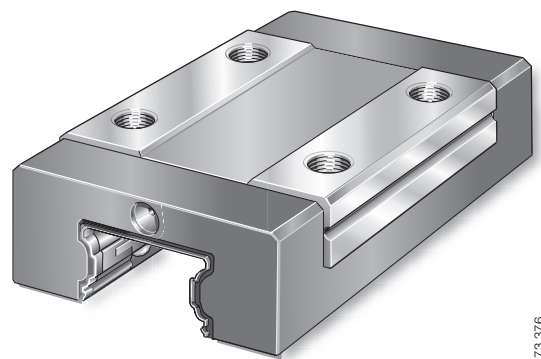

173 876

- saddle plate made from corrosion-resistant, hardened steel, rolling element raceways precision ground
 - balls are recirculated in enclosed channels with plastic return elements
- end pieces with gap seals and lubrication holes
 - lubrication nipple supplied with size 15



Guideway – corrosion-resistant

TKMD..C

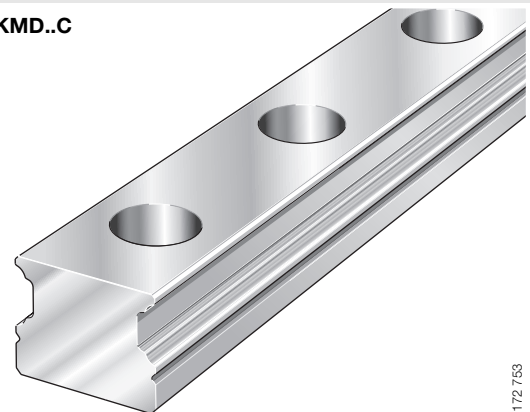

172 753

- corrosion-resistant steel, hardened and ground on all faces, rolling element raceways precision ground
- located from above
- one row of holes for fixing screws
 - though holes with counterbores



Four-row miniature linear recirculating ball bearing and guideway assemblies – corrosion-resistant

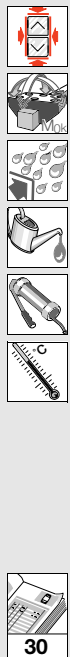

KUME..C

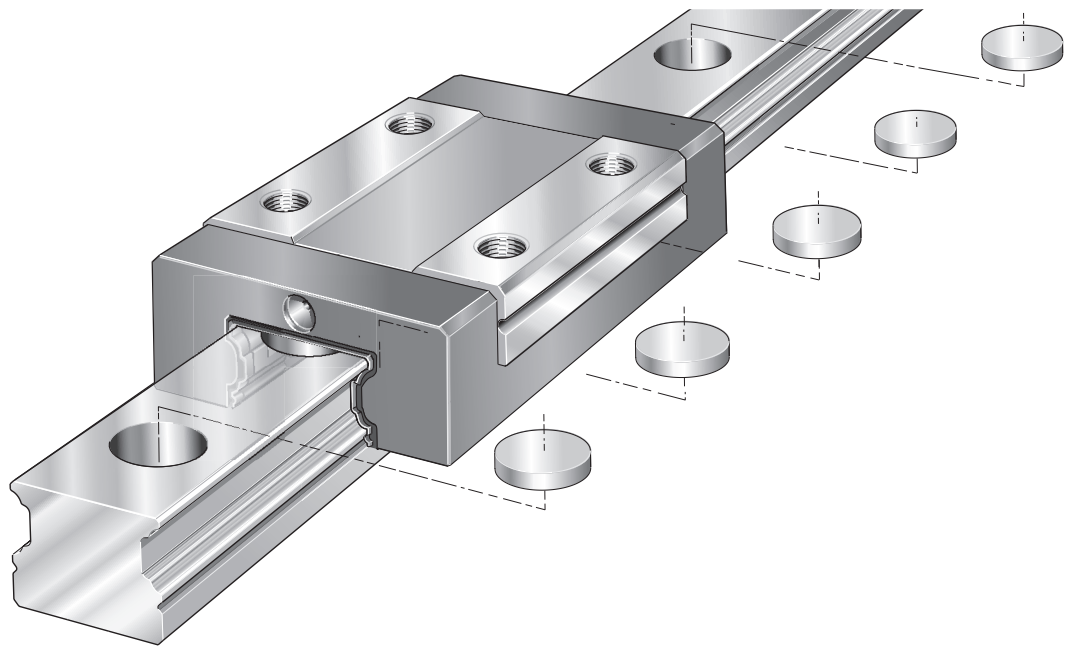

173 377

Accessories

MKMD

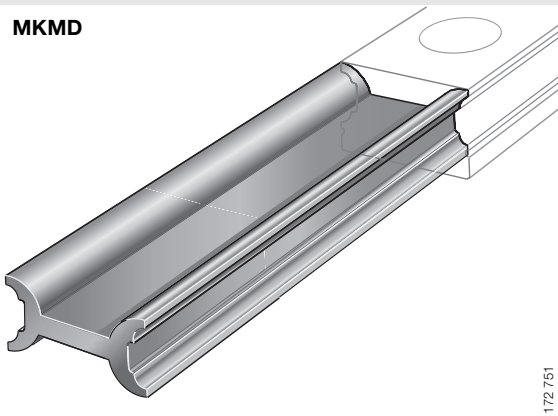

172 751

- dummy guideway made from plastic
 - prevents damage to the rolling element set if the carriages are separated from the guideway. The carriages are always pushed direct from the guideway onto the dummy guideway

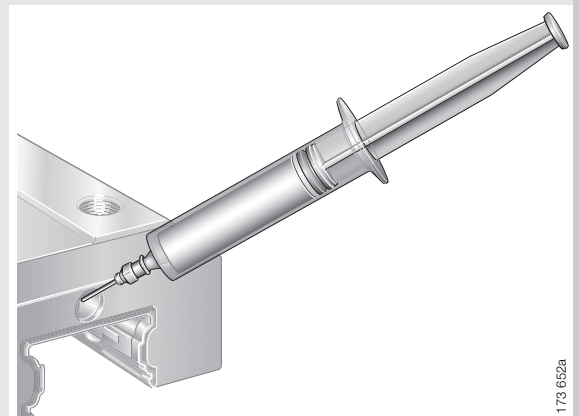

173 652a

- grease injector for greasing of carriages

Four-row miniature linear recirculating ball bearing and guideway assemblies

corrosion-resistant



Design and safety guidelines

Load carrying capacity and life

The size of the guidance unit is determined by the load carrying capacity of the individual elements. The load carrying capacity is described in terms of the basic dynamic load rating C and basic static load rating C_0 (*dimension table*).

Basic rating life

The basic rating life is determined as follows:

$$L = \left(\frac{C}{P}\right)^p$$

$$L_h = \frac{8,33 \cdot 10^5}{H \cdot n_{osc}} \cdot \left(\frac{C}{P}\right)^p$$

Static load safety factor

The static load safety factor S_0 indicates the security with regard to permissible permanent deformation in the bearing without affecting the guidance accuracy and smooth running of the bearing.

It can be determined using the following formula:

$$S_0 = \frac{C_0}{P_0}$$

$$S_0 = \frac{M_0}{M}$$



If high demands are placed on accuracy and smoothness of running, the static load safety factor should not be less than $S_0 = 3$.

For high loads, the load carrying capacity of the fixing screws must be checked (see VDI Guideline 2 230)!

The equivalent static bearing load is determined by the maximum load F_{max} .

$$P_0 = F_{max}$$

$$M_0 = M_{max}$$

C N
Basic dynamic load rating (*dimension table*)

C_0 N
Basic static load rating (*dimension table*)

H mm
Distance between ends of stroke

L mm
Basic rating life in 100 000 m

L_h h
Basic rating life in operating hours

M Nm
Equivalent static moment in load direction

M_0 Nm
Basic static moment rating in load direction (M_{0x} , M_{0y} , M_{0z} from *dimension table*)

n_{osc} min⁻¹
Number of return strokes per minute

p –
Life exponent $p = 3$

P N
Equivalent dynamic load

P_0 N
Maximum equivalent static load

S_0 –
Static load safety factor.

Conversion

Basic load ratings to DIN, basic load ratings as used in the Far East

Ball monorail guidance systems

$$C_{50000} = 1,26 \cdot C_{DIN}$$

$$C_{DIN} = 0,79 \cdot C_{50000}$$

C_{DIN} N
Basic dynamic load rating C for distance of 100 000 m – definition to DIN 636

C_{50000} N
Basic dynamic load rating C for distance of 50 000 m.

Delivered condition

Guideways and carriages are supplied assembled. At least one carriage ② is located on one guideway ① (Figure 1).

Miniature linear recirculating ball bearing and guideway assemblies are supplied protected by a preservative. The preservative is compatible with oils and greases.

Initial operation

The carriage must be oiled or greased before initial operation and protected against solid and liquid contaminants.

Lubrication

Lubrication can be carried out using conventional pointed nozzles.



Grease guns should not be used since the bearing may be damaged by the forces involved.

The carriage should be moved during lubrication, especially when using grease lubrication. This gives uniform distribution of the lubricant.

Excessive greasing has a negative influence on the behaviour of the bearing.

Corrosion-resistant design



The miniature linear recirculating ball bearing and guideway assemblies are corrosion-resistant due to the steels used in the manufacture of the saddle plates and guideways.

If very high levels of corrosion resistance are required, however, the suitability of the unit for the specific application must be investigated.



Preload

Miniature linear recirculating ball bearing and guideway assemblies KUME..C are available in the preload classes according to Table 1.

Increasing the preload has the effect of increasing:

- the rigidity
- the moment load carrying capacity
- the guidance accuracy.

However, preload also influences the displacement resistance and the operating life of recirculating guidance systems.

Table 1 · Preload

Preload class	Preload setting
V0 (standard)	zero to light preload
V1	preload

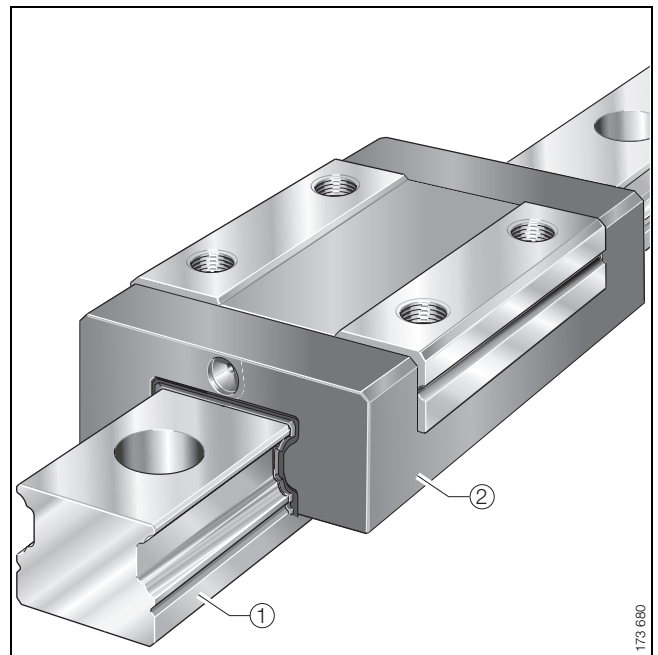

Figure 1 · Scope of delivery – guideway and carriage

173 680

Four-row miniature linear recirculating ball bearing and guideway assemblies

corrosion-resistant



Accuracy

Four-row linear recirculating ball bearing and guideway assemblies are supplied in accuracy class G2.

For accuracy class tolerances, see Table 2 and Figure 2, for reference dimensions see Figure 3.

The tolerances are arithmetic mean values (Figure 2 and Table 2). They relate to the centre point of the screw mounting or locating surfaces of the carriage. The dimensions H and A₁ should always remain within the tolerance irrespective of the position of the carriage on the guideway.

Table 2 · Accuracy class and tolerances

Tolerance		Accuracy class G2 μm
for height	H	±20
Height difference ¹⁾	ΔH	15
for distance	A ₁	±25
Distance difference ¹⁾	ΔA ₁	20

¹⁾ Dimensional difference between several carriages on one guideway, measured at the same point on the guideway.

Parallelism of raceways to locating surfaces

Parallelism tolerances of guideways: see Figure 2.

Tolerances of guideways

Tolerances: see Figure 4 and Table 3.

Table 3 · Length tolerances

Guideway Designation	Tolerances of guideways	
	$l_{max} \leq 300$ mm	$l_{max} > 300$ mm
TKMD..C	±0,3 mm	±0,1% of guideway length

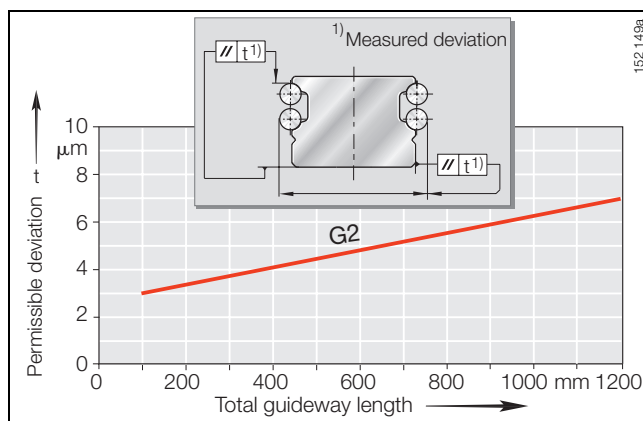

Figure 2 · Accuracy class and parallelism tolerances of guideways

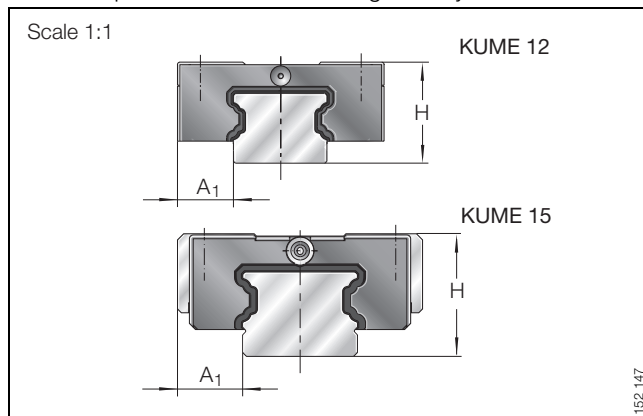

Figure 3 · Reference dimensions for accuracy

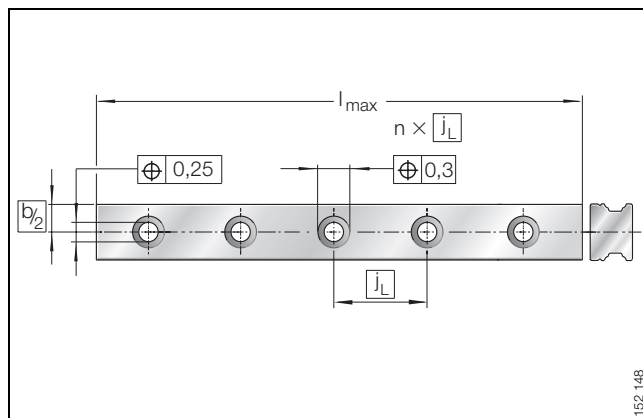

Figure 4 · Positional and length tolerances of guideways – hole pattern to ISO 1101

Hole patterns of guideways

The guideways have a symmetrical hole pattern (Figure 5). For an asymmetrical hole pattern (customer request), the following must apply:

- $a_L \geq a_{L\min}$ and $a_R \geq a_{R\min}$ (Figure 5).

Maximum number of pitches between holes

The number of pitches between holes is the rounded whole number equivalent to:

$$n = \frac{l_{\max} - (2 \cdot a_{L\min})}{j_L}$$

The distances a_L and a_R are generally determined by:

$$a_L + a_R = l_{\max} - n \cdot j_L$$

For guideways with a symmetrical hole pattern:

$$a_L = a_R = \frac{1}{2} \cdot (l_{\max} - n \cdot j_L)$$

Number of holes:

$$x = n + 1$$

a_L, a_R mm
Distance between start or end of guideway and nearest hole

$a_{L\min}, a_{R\min}$ mm
Minimum values for a_L, a_R according to *Dimension table*

l_{\max} mm
Guideway length

n -
Maximum number of pitches between holes

j_L mm
Distance between holes

x -
Number of holes.



The minimum and maximum values for $a_{L\min}$ and $a_{R\min}$ must be observed, otherwise the counterbores may be intersected by the end of the guideway.

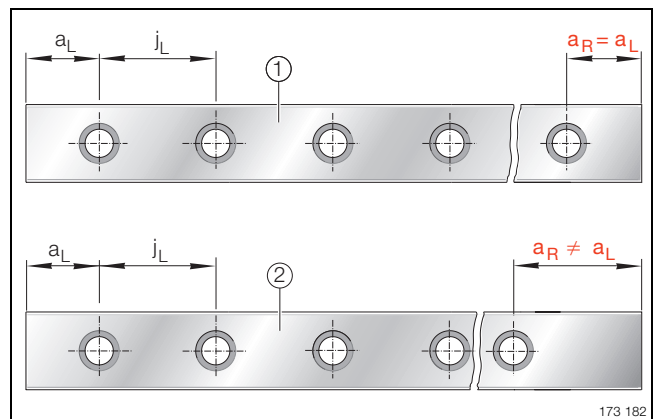

Figure 5 · Symmetrical ① and asymmetrical ② hole patterns for guideways with one row of holes

Four-row miniature linear recirculating ball bearing and guideway assemblies

corrosion-resistant



Demands on the adjacent construction

The design of the bearing arrangement is essentially determined by the requirements for accuracy, rigidity and load carrying capacity of the bearing arrangement. This has a direct influence on the adjacent construction and primarily concerns:

- the geometrical and positional accuracy of the mounting surfaces
- the location of the guidance elements.



Ensure that the adjacent construction has adequate strength.

Geometrical and positional accuracy of the mounting surfaces

Observe the tolerances for the support and locating surfaces in accordance with Figure 6, Figure 7 and Table 5. Surfaces should be ground or precision milled. A mean roughness value of $R_a 1,6$ should be achieved.



If these tolerances are not met:

- this will impair the overall accuracy of the guidance system
- the preload will be affected
- the operating life of the guidance system will be reduced.

For ΔH (Figure 6, Figure 7), deviations are permissible in accordance with the following formula. If the deviation is greater than this, please consult INA.

$$\Delta H = a \cdot b$$

ΔH μm

Maximum permissible deviation from the theoretically precise position

a -

Factor dependent on bearing size (Table 4).

This factor is valid for a guidance system set free from clearance

b mm

Centre distance between guidance elements.

Table 4 · Factor dependent on bearing size

Miniature ball bearing and guideway assembly	Factor
Designation	a
KUME 12 C	0,05
KUME 15 C	0,1

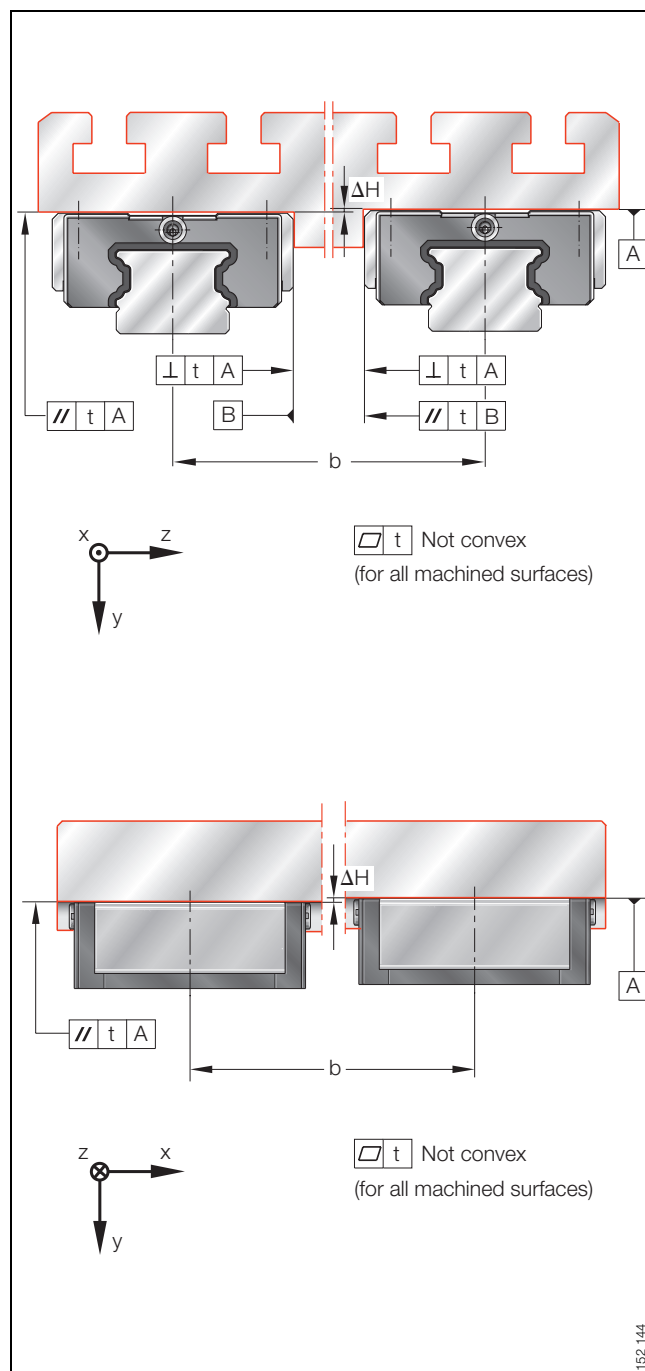

Figure 6 · Tolerances for mounting surfaces

Parallelism of mounted guideways

For guideways arranged parallel to each other, the parallelism value t given in Figure 7 and Table 5 should be adhered to.

If the maximum values are used, this may increase the displacement resistance. For larger tolerances, please consult INA.

For calculation of ΔH , see page 26.

Table 5 · Values for t

Guideway Designation	t μm
TKMD 12 C	5
TKMD 15 C	7

Locating heights and corner radii

Locating heights and corner radii should be in accordance with Figure 8 and Table 6.

Table 6 · Locating heights and corner radii

Miniature linear recirculating ball bearing and guideway assembly Designation	Locating heights and corner radii			
	h_1	$h_2 \text{ max}$	$r_1 \text{ max}$	$r_2 \text{ max}$
KUME 12 C	3	2,5	0,4	0,4
KUME 15 C	5	3	0,7	0,4

Sealing

In order to prevent damage to the guidance systems, the raceways must be kept clean at all times. If the end pieces used as standard are not adequate for this purpose, additional seals must be provided in the adjacent construction.

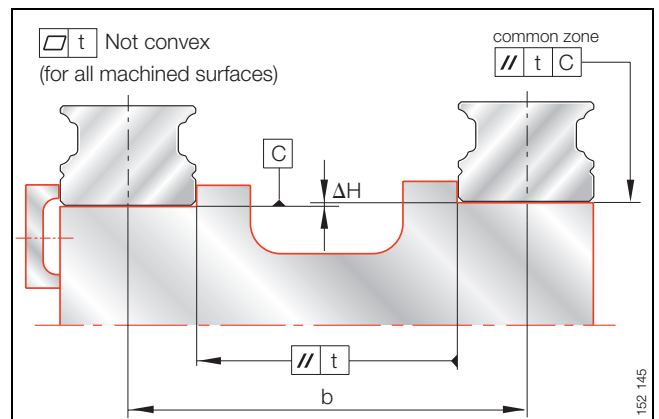

Figure 7 · Parallelism of mounted guideways

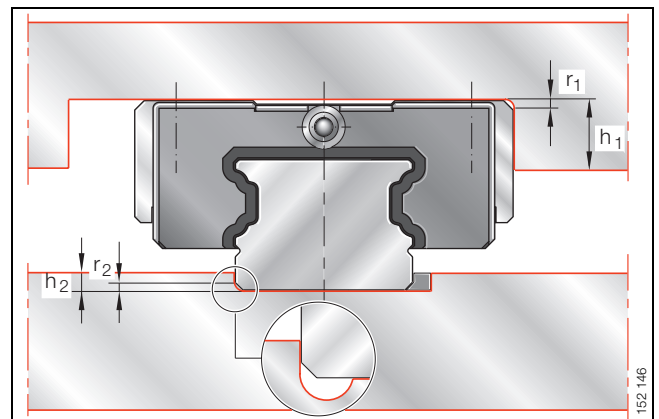

Figure 8 · Locating heights and corner radii

Four-row miniature linear recirculating ball bearing and guideway assemblies

corrosion-resistant



Accessories

The linear recirculating ball bearing and guideway assemblies can be fitted with contact wipers:

- suffix PP.



Ordering example and ordering designation

Asymmetrical hole pattern	
Miniature linear recirculating ball bearing and guideway assembly, with clearance	KUME..C
Size	12
Number of carriages per guideway	W2
Guideway length	215 mm
■ a_L	9 mm
■ a_R	6 mm

Ordering designation:

1 off KUME 12 C W2/215-9/6 (Figure 9).

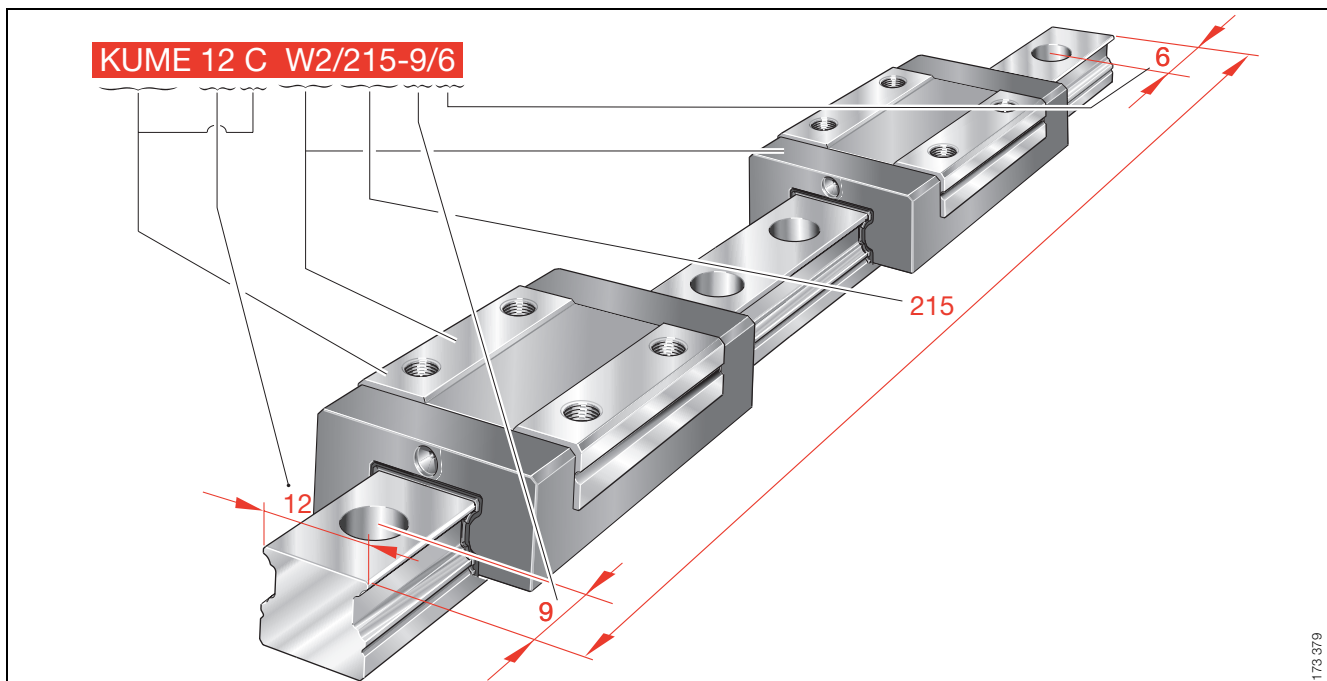

Figure 9 · Ordering example, ordering designation

Four-row miniature linear recirculating ball bearing and guideway assemblies

corrosion-resistant

Series KUME..C

Dimension table · Dimensions in mm															
Carriage		Guideway		Closing plug	Mounting dimensions				Dimensions						
Designation	Mass m ≈kg	Designation	Mass m ≈kg/m		$l_{max}^{1)}$	H	B	L	A_1	J_B	b	A_2	L_1	J_L	j_L
KWME 12 C	0,03	TKMD 12 C	0,6	KA 6 TN	1000	13	27	35,8	7,5	20	12	3,5	23,2	15	25
KWME 15 C	0,06	TKMD 15 C	1,1	KA 6 TN	1200	16	32	44	8,5	25	15	3,5	28	20	40

1) Maximum length l_{max} of guideways; longer guideways by agreement.

2) If there is a possibility of settling, the fixing screws should be secured against rotation.

Thread, screw and tightening torques²⁾

Unit Designation	K_1 for screw ISO 4762-12.9		G_2 for screw ISO 4762-12.9	
		Nm max.		Nm max.
KUME 12 C	M3	2,2	M3	2,2
KUME 15 C	M3	2,2	M3	2,2

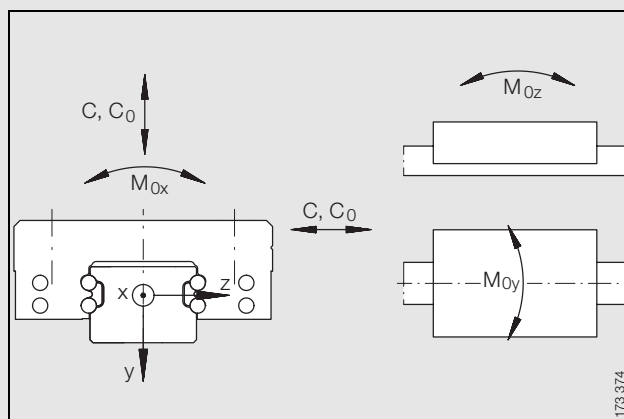

Load directions

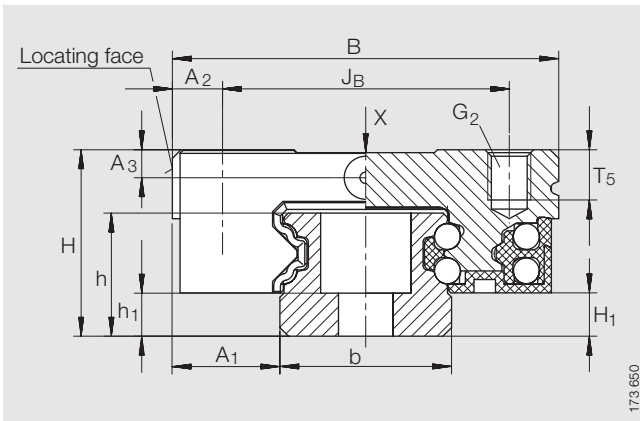

KUME..C

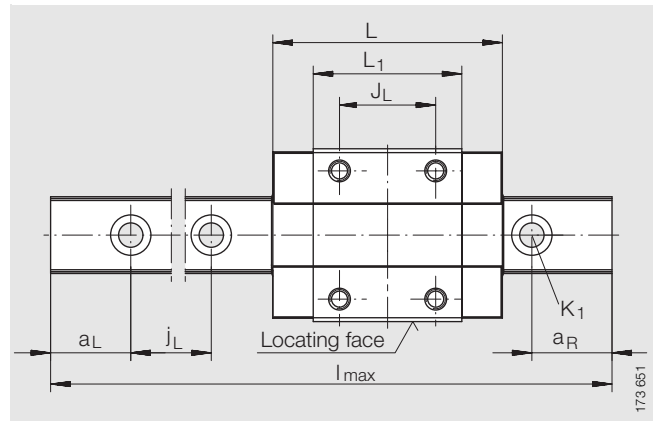

KUME..C · View X (rotated 90°)

									Load carrying capacity				
a _L		a _R		H ₁	T ₅	A ₃	h	h ₁	Basic load ratings		Moment ratings		
									C	C ₀	M _{0x}	M _{0y}	M _{0z}
min.	max.	min.	max.						N	N	Nm	Nm	Nm
5	20	5	20	3	3,5	1,95	8,6	3	2900	5200	33	17	17
6	34	6	34	3,5	4	2,46	10,6	4,1	4400	8300	67	34	34



INA-Schaeffler KG

Linear Technology Division
66406 Homburg (Saar) · Germany

Internet www.ina.com

E-Mail info.linear@de.ina.com

In Germany:

Telephone 0180/5 00 38 72

Fax 0180/5 00 38 73

From other countries:

Telephone +49/68 41/7 01-0

Fax +49/68 41/7 01-6 25