

GMN



High precision ball bearings

GMN Paul Müller Industrie GmbH & Co. KG
Äussere Bayreuther Str. 230 · D-90411 Nuremberg
Phone: +49 911-5691-0 · Fax: +49 911-5691-221
www.gmn.de

Ball bearings:

Phone: +49 911-56 91-249 · Fax: +49 911-5691-587
email: vertrieb.kula@gmn.de

Official GMN agency:

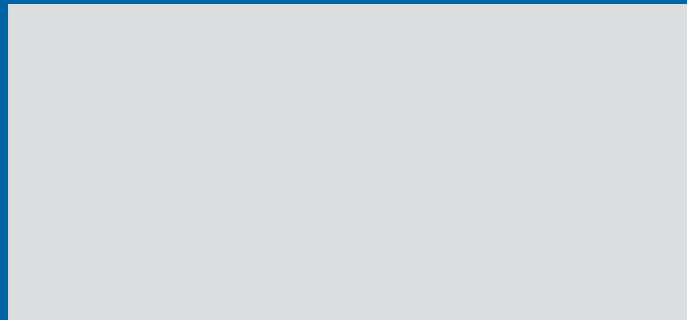

**Contents:****GMN**

High precision ball bearings
Page 4

Product overview
Page 6

Spindle ball bearings

Page 8

Materials
Page 10

Standard series
S, SM, KH
Page 14

Special designs
for direct lubrication
+A, +AB, +L, +LB, +AG
Page 16

Special series
BHT, BNT
Page 19

Bearing designation
Bearing data
Page 20

Comparable
bearing types
Page 44

Deep groove ball bearings

Page 45

Types, materials
Page 46

Bearing designation
Bearing data
Page 50

Engineering

Page 56

Bearing selection
Page 57

Preload
Page 60

Bearing arrangements
Page 64

Spacers
Page 66

Contact angle
Matching accuracy
Page 67

Precision classes
Page 68

Accuracy of associated com-
ponents
Page 70

Bearing lubrication
Page 72

Speed limits
Page 80

Storage
Page 82

Installation preparation
Page 82

Grease distribution run

Page 83

Tightening torques for
precision nuts
Page 84

Bearing calculation
Page 86

Service life of grease
Page 90

Static load capacity
Page 91

Bearing frequencies
Page 92

Service

Bearing analysis
Consultation
Training courses
Page 93

Special applications
Page 94

Index
Page 96

Internet
Quality management
Page 98



GMN High precision ball bearings

On the basis of long experience in the development and production of high-quality machine components, GMN has specialized in the field of high-precision ball bearings to manufacture high performance, long-life deep groove and spindle bearings.

Certification under international standards guarantees the highest levels of precision in the development and production of GMN ball bearings and secures consistently outstanding quality characteristics with regard to speed suitability, stability and durability.

This comprehensive product line comprises – in addition to a large number of standard solutions – also special designs optimized for specific demands.

GMN Spindle ball bearings

GMN Deep groove ball bearings

Standard series: S, SM, KH

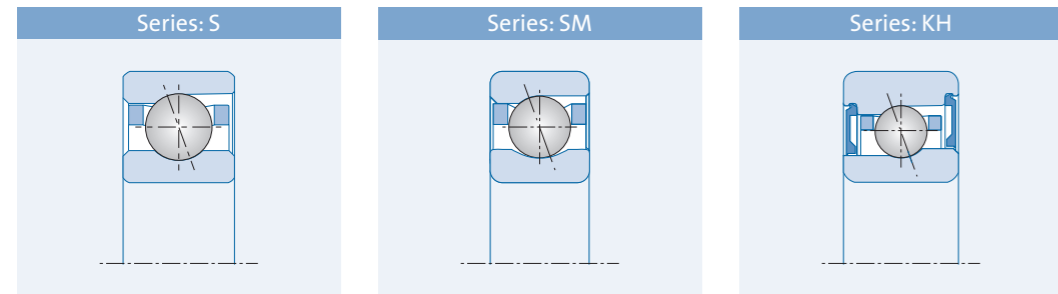

Special design (oil lubrication): +A, +AB, +L, +LB

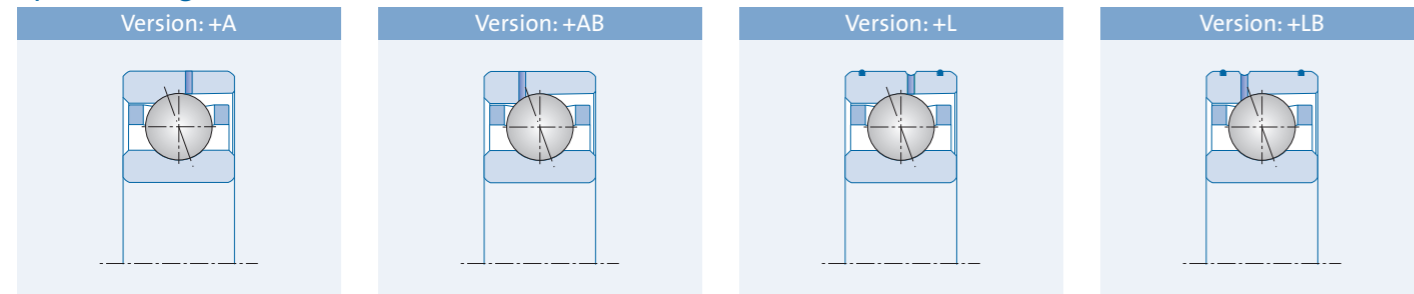

Special design (grease lubrication): +AG

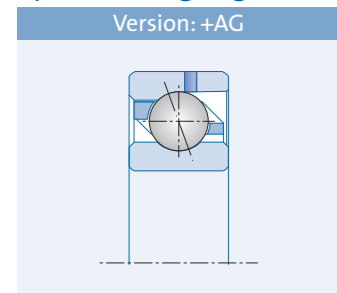

Special series (separable type): BHT, BNT

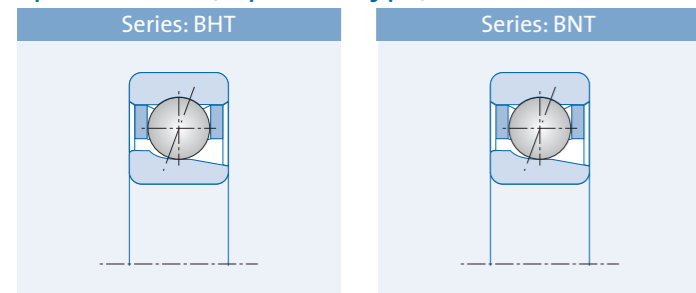

Series S

- Standard bearing
- Reference speed coefficient: $1.7 \cdot 10^6$ mm/min

Series SM

- Optimized inner ring geometry
- Reference speed coefficient: $2.0 \cdot 10^6$ mm/min

Series KH

- Sealed for lifetime grease lubrication
- or open for oil lubrication
- Reference speed coefficient: $2.1 \cdot 10^6$ mm/min

Version +A

- Oil supply through outer ring (open side)
- Optimized for minimum quantity lubrication

Version +AB

- Oil supply through outer ring (closed side)
- Optimized for minimum quantity lubrication

Version +L

- Oil supply through outer ring (open side)
- Optimized for minimum quantity lubrication
- with perimeter ring groove and O-ring (seal)

Version +LB

- Oil supply through outer ring (closed side)
- Optimized for minimum quantity lubrication
- with perimeter ring groove and O-ring (seal)

Version +AG

- Grease re-lubrication through outer ring
- Increased service life or speed

Series BHT

- Ball retaining cage, guided on outer ring
- Bevel form as series SM
- Reference speed coefficient: $1.8 \cdot 10^6$ mm/min

Series BNT

- Ball retaining cage, guided on outer ring
- Bevel form as series S
- Reference speed coefficient: $1.5 \cdot 10^6$ mm/min

Standard series: 60../62..

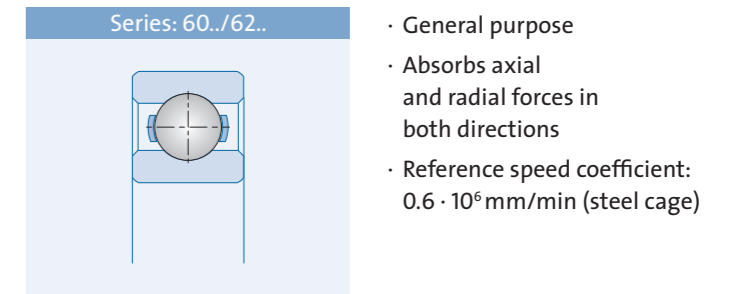

- General purpose
- Absorbs axial and radial forces in both directions
- Reference speed coefficient: $0.6 \cdot 10^6$ mm/min (steel cage)

Special design (1 shield): Z

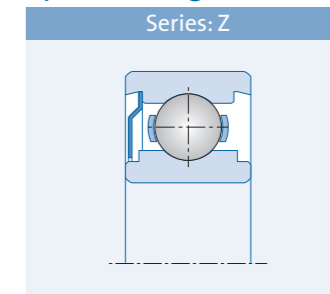

- Version with one shield
- Greased

Special design (2 shields): ZZ

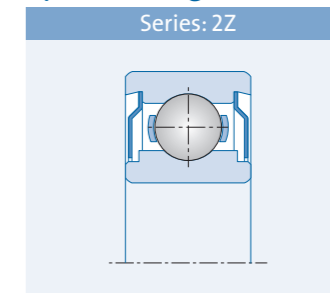

- Version with two shields
- Greased

Special design (2 shields): XZZ

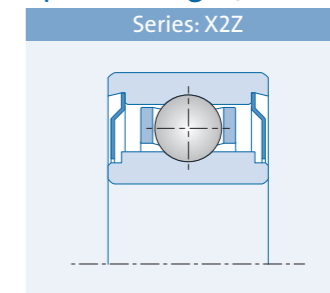

- Extra-wide design with two shields
- Greased
- Reference speed coefficient: $1.0 \cdot 10^6$ mm/min

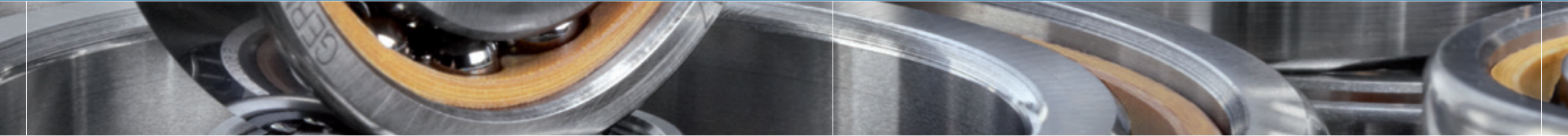

GMN High precision spindle ball bearings

- Materials
- Hybrid ball bearings
- Standard series
- Special designs
- Special series
- Bearing designation
- Bearing data

Product characteristics:

- Bore diameter 5–120 mm
- Nominal contact angle 15°–25°
- Forces are transmitted from one raceway to the other under this pressure angle
- Optimized for maximum speeds
- Absorbs large radial and axial loads
- Placement against a second bearing is necessary
- Larger number of balls than with deep groove ball bearings
- Great rigidity and load capacity
- All series and sizes are available as hybrid bearings
- All GMN ball bearings are available greased
- All GMN bearing bore sizes are available with various outer diameters

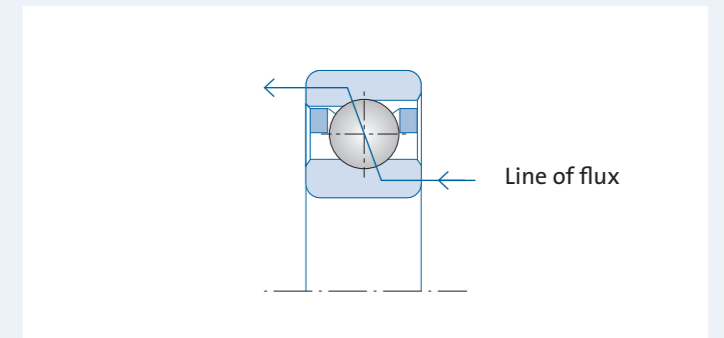

GMN spindle ball bearings: Bore diameter / Outer diameter

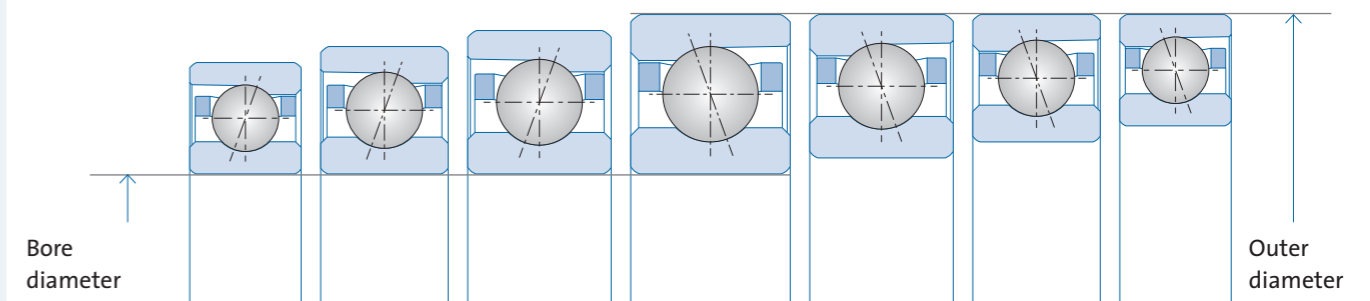

GMN series:	S 618..	S 619..	S 60..	S 62..	S 60..	S 619..	S 618..
ISO series:	18	19	10	02	10	19	18

Boundary dimensions per DIN, ISO and ABMA

Materials Rings

GMN uses only high-quality materials and processing techniques to manufacture all components of its high precision spindle ball bearings. The highest standards of quality assure the best possible performance efficiency and optimal service life for GMN products.

Inner and outer ring

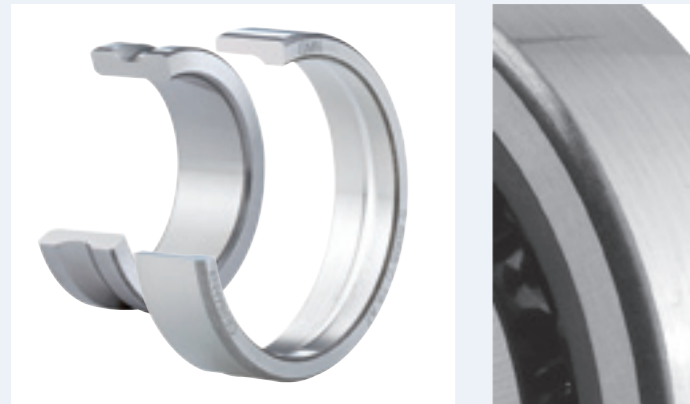

Material
Bearing steel (chrome steel) 100 Cr 6
Material no. 1.3505, SAE 52100, SUJ2
Special steels on request

Permissible operating temperature
Heat treated for continuous operating temperatures up to 150° C

Hardness
60 to 64 HRC, fully hardened; corresponds to 700–800 HV30

Characteristics
High purity and homogeneity, vacuum-degassed

Cages

GMN ball bearing components are continuously being optimized by ongoing development efforts to further improve their technical characteristics. Due to their outstanding characteristics, cage types TA and TXM exhibit exceptional performance with respect to speed, load capacity and service life.

TA cage



Material
Laminated phenolic resin
Phenolic resin with fine mesh cotton webbing

Permissible operating temperature
120° C

Cage guidance
on outer ring

Fabrication
machining

Application
for S, SM, KH series
general purpose

Characteristics
low friction coefficient,
for oil and grease lubrication

TXM cage



Material
Partially crystalline high performance plastic
PEEK (polyetheretherketone), carbon fiber reinforced

Permissible operating temperature
250° C

Cage guidance
on outer ring, ball retaining

Fabrication
injection molded

Application
for S, SM series
optimized for grease lubrication

Characteristics
low friction coefficient,
reduces/eliminates cage vibrations
great mechanical, chemical and thermal stability

Advantages:

- High resistance to wear
- Outstanding emergency operating characteristics due to favorable sliding properties and reduced abrasion
- Reduced operating temperature due to lower friction and more favorable tribology
- Constant grease lubrication due to the formation of grease reservoirs in provided cage pockets
- Long service life
- Increased cost effectiveness

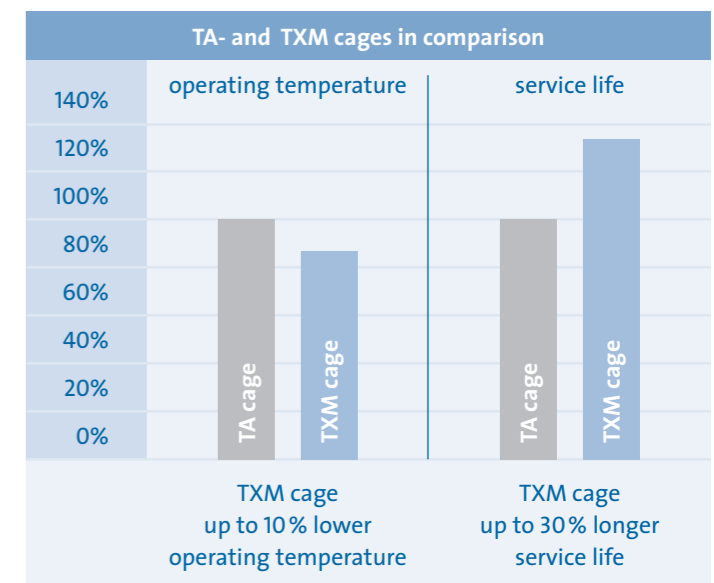

Other cage materials, types, special treatments (e.g. TB, brass, Torlon, silver-coated aluminum bronze) are available on request.

Materials Balls

Hybrid ball bearings

Hybrid ball bearings are characterized by a combination of materials; bearing steel (inner and outer rings) and ceramic (balls). The material-based characteristics of ceramic balls (in comparison to bearings with steel balls) offer clear performance improvements, especially under critical conditions in machine operation.

balls (standard material)



Material
 Bearing steel (chrome steel) 100 Cr 6
 Material no. 1.3505, SAE 52100, SUJ2
 Special steels on request

Permissible operating temperature
 Heat treated for continuous operating temperatures up to 150°C

Hardness
 60 to 64 HRC, fully hardened; corresponds to 700–800 HV30

Characteristics
 High purity and homogeneity, vacuum-degassed

Balls (hybrid ball bearings)



Material
 Ceramic (silicon nitride Si₃N₄)

- Material characteristics**
- Low chemical affinity to 100 Cr 6
 - Low friction coefficient
 - Low heat conductivity
 - Corrosion resistance
 - Non magnetic
 - Electrically insulating

Longer service life
 Because of their material characteristics, hybrid bearings are able to attain more than twice the service life of steel bearings. Machine operation time is significantly increased.

Higher speeds
 Due to their tribological characteristics and lower mass forces, speeds can be increased as much as 30% in comparison with steel balls.

Low-cost lubrication
 The maximum speed for grease and oil lubrication is increased. Therefore grease lubrication can frequently be used instead of cost-intensive oil lubrication.

Greater rigidity
 The characteristics of the materials improve both radial and axial rigidity. The advantages here are increased accuracy and a shift of critical resonance.

Improved machining accuracy
 Greater bearing rigidity, reduced thermal expansion and lower vibration excitation make it possible to achieve maximum processing accuracy.

- Application examples**
- Machine tool spindles
 - Fast running machine bearing journals
 - Lifetime optimized precision bearings

Characteristics of ceramics (silicon nitride) Si₃N₄ and bearing steel (chrome steel) 100 Cr 6

Characteristics at room temperature		Ceramic Si ₃ N ₄	Steel 100 Cr 6
Density	[g/cm ³]	3.2	7.8
Expansion coefficient	[10 ⁻⁶ /K]	3.2	11.5
E-modulus	[GPa]	315	210
Poisson's ratio	-	0.26	0.3
Vickers hardness HV10	-	1600	700
Tensile strength	[MPa]	700	2500
Fracture toughness	[MPa m ^{0.5}]	7	20
Thermal conductivity	[W/mK]	30–35	40–45
Specific electrical resistance	[Ωmm ² /m]	10 ¹⁷ –10 ¹⁸	0.1–1

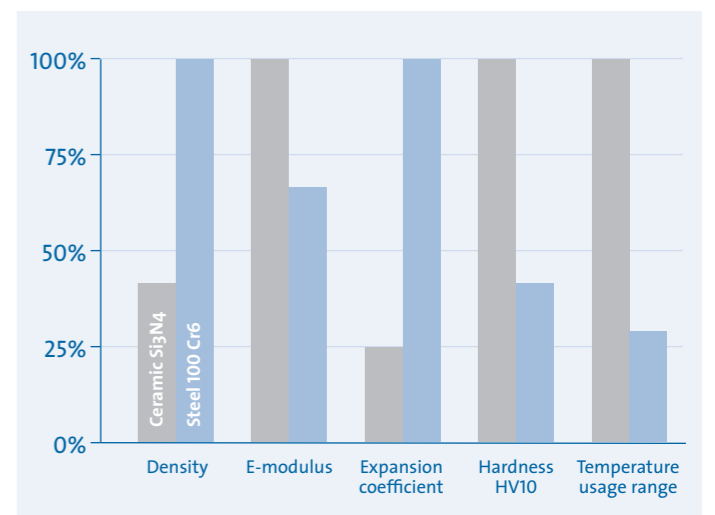
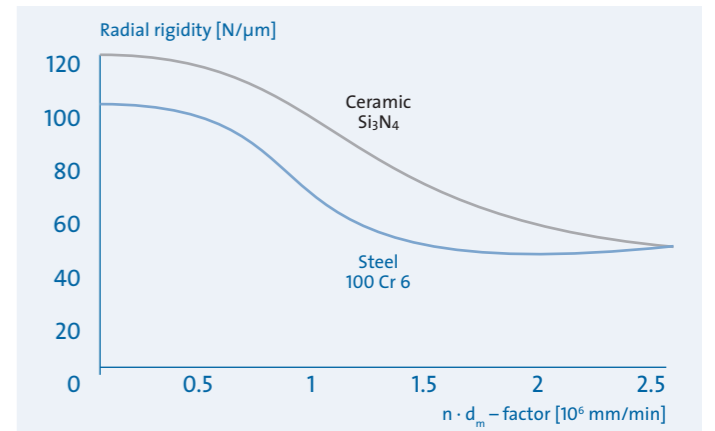
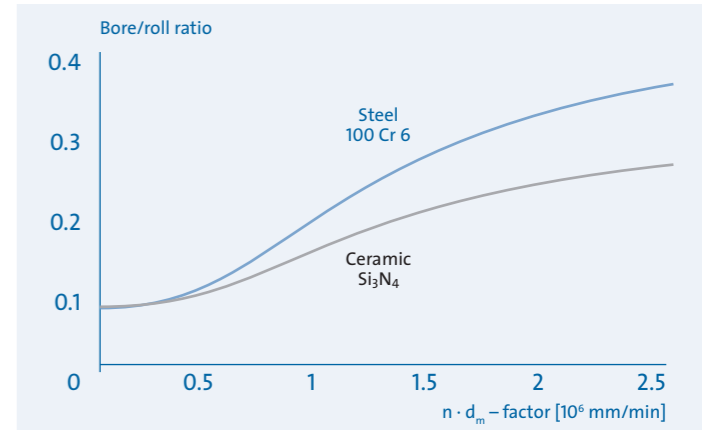

Standard series

Standard S, SM and KH series spindle bearings from GMN cover a comprehensive range of sizes, types and designs.

Based on a diverse choice of products, GMN offers quality-oriented and economic spindle bearing solutions for a large number of specific requirements.

Series S

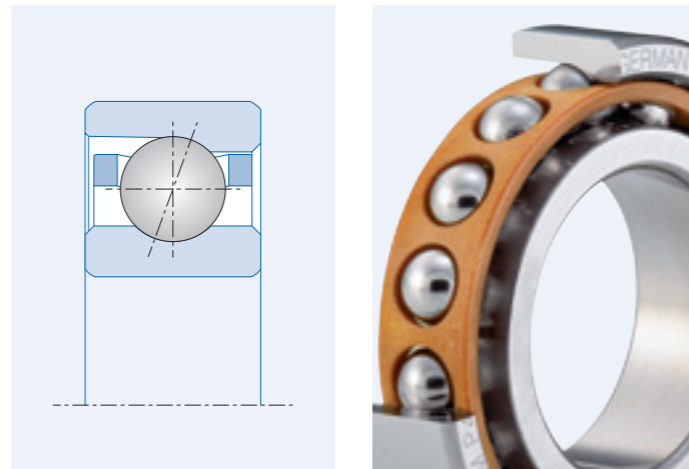

The GMN Series S product line covers an extensive range of dimensions, speed suitability and load carrying capacity.

- Standard spindle bearings
- High speed suitability and rigidity
- Highly economical and reliable

Series SM

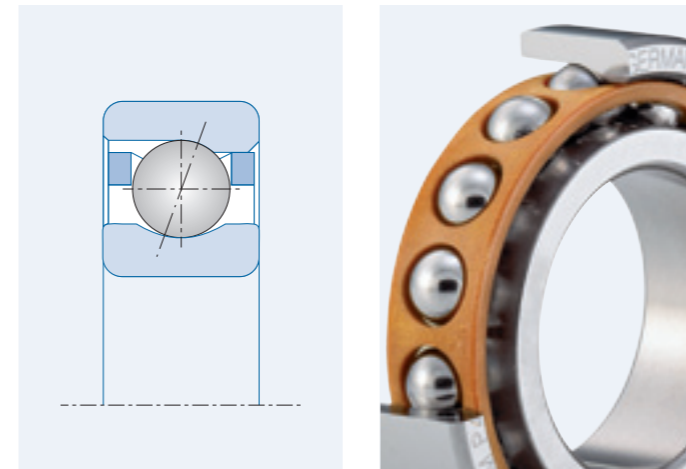

Due to optimized inner geometry, GMN Series SM permits almost 20% higher speeds – in comparison to Series S.

- Optimized inner ring bevel form for high speeds
- Long service life because friction is minimized
- Highly resistant to temperature influences due to large radial bearing clearance
- Low operating temperature due to minimal friction

Series KH

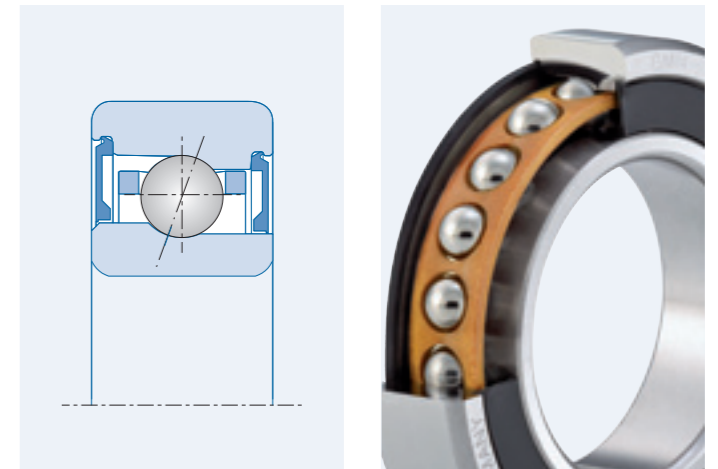

Because bearing geometry is optimized, the GMN Series KH provides outstanding speed properties, service life and economy.

- **Sealed:** with permanent grease lubrication
Standard grease (Lubcon HS Turmogrease L252) or customer-specific grease
- **Open:** for oil lubrication
- Optimized for highest speeds
- Low operating temperature due to optimized raceway geometry
- High resistance to temperature influences due to large radial bearing clearance
- Optimized ratio of ball complement and ball diameter to load rating
- Optimized inner geometry with respect to grease space and oil lubrication
- No reduction of speed due to non-contact seals (seal temperature stable up to 120°C)
- No grease escapes in vertical or inclined installation position
- Reduced grease desiccation due to air flow
- No additional sealing elements needed
- Less sensitive to assembly area contamination

Special designs Direct oil lubrication

Conventional oil-lubricated spindle bearings are provided with oil through an oil supply hole located on the side.

GMN spindle bearing designs +A, +AB, +L and +LB permit a direct supply of oil to the point of lubrication through a hole in the outer ring.

Special design +A

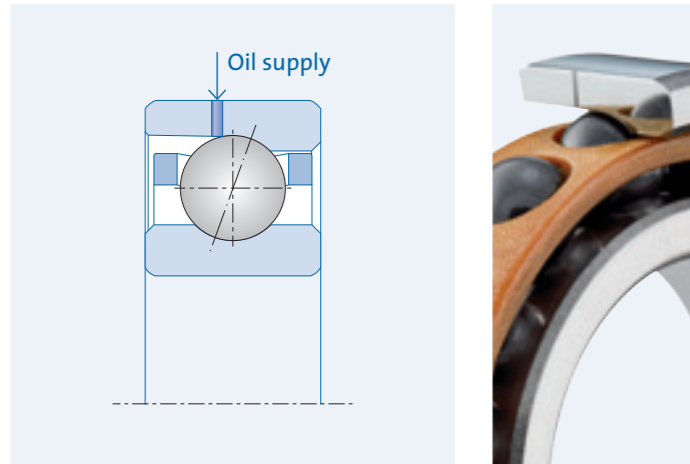

Lubrication hole to the raceway on the open side

- Optimized for highest speeds
- Reduced bearing wear
- High operating security
- Suffix A (designation example: HY SMA 6005)

Special design +AB

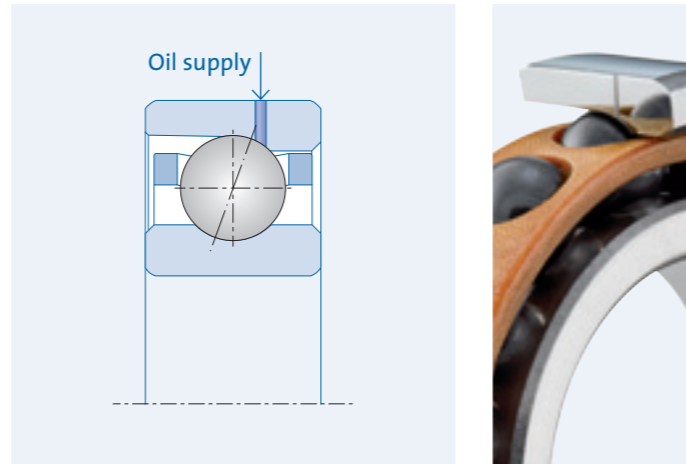

Lubrication hole to the raceway on the closed side

- Optimized for highest speeds
- Reduced bearing wear
- High operating security
- Suffix AB (designation example: HY SMAB 6006)

Special design +L

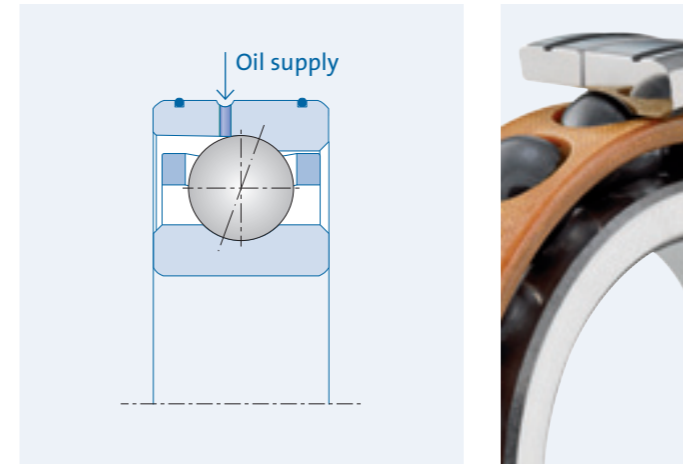

Lubrication hole to the raceway on the open side and sealed with O-rings

- Optimized for highest speeds
- Reduced bearing wear
- High operating security
- High oil position compatibility (ring groove) in the housing
- Additional outer ring seal
- Suffix L (designation example: HY SML 6007)

Special design +LB

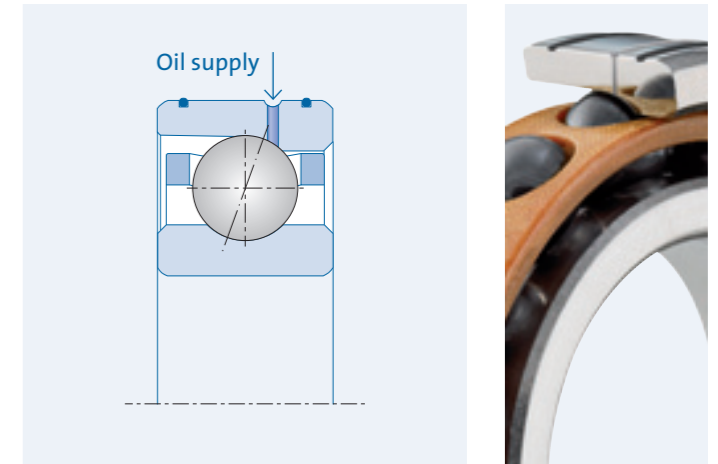

Lubrication hole to the raceway on the closed side and sealed with O-rings

- Optimized for highest speeds
- Reduced bearing wear
- High operating security
- High oil position compatibility (ring groove) in the housing
- Additional outer ring seal
- Suffix LB (designation example: HY SMLB 6008)

Special designs Grease re-lubrication

To assure maximum machine operation time, GMN also offers spindle bearings which can deliver regulated quantities of lubricant through holes in the outer ring directly to the point of lubrication without complex oil lubricant supply systems.

Special design +AG

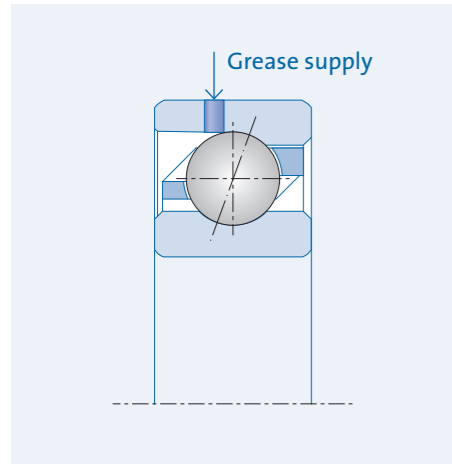

Lubrication holes to the raceway on the open side

- Optimized for maximum speeds (speed factor $n \cdot dm$ up to $2.3 \cdot 10^6$ mm/min)
- Maximum service life (up to factor 10)
- Reduced overhead for grease distribution
- High operating security
- Low capital expenditure
- Suffix AG (designation example: HY SMAG 6005)

Re-lubrication system

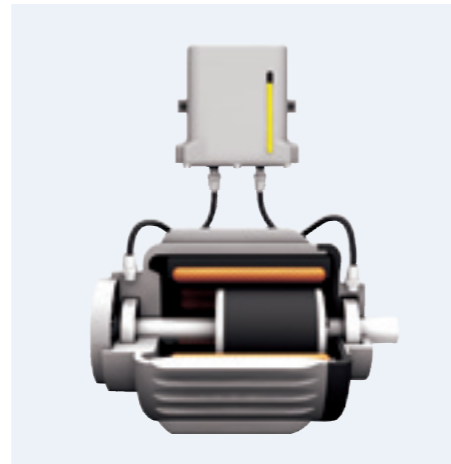

Re-lubrication unit and lubricant supply

- Exactly dosed and delivered grease quantity
- Lubricant matched to bearing requirements
- Small space requirement
- Simple assembly and handling
- Minimal operating costs (no compressed air, oil consumption)
- Fully automatic or machine controlled lubrication
- Individually programmable operating time
- Minimum design effort

Complete bearing

- Increase of permissible speed range with grease lubrication
- Optimal, long-term lubricant supply
- Simple system technology

Special series Separable bearings

The BHT and BNT series bearings developed by GMN are fully capable bearing assemblies which can be disassembled quickly to assure fast, uncomplicated handling for assembly and maintenance.

Series BNT

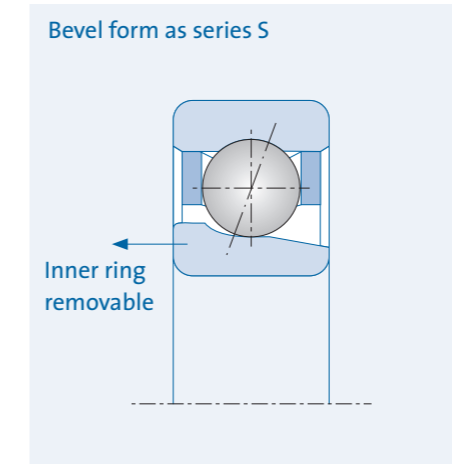

- Ball-retaining cage (balls do not fall out when the inner ring is removed)
- Cage is guided by outer ring shoulders
- Simple assembly (inner and outer rings are installed separately)
- Rotating parts can be balanced with inner ring installed
- Bearing axial clearance can be defined

Series BHT

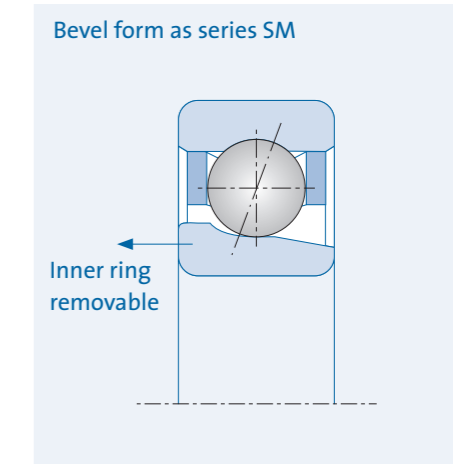

- Ball-retaining cage (balls do not fall out when the inner ring is removed)
- Cage is guided by outer ring shoulders
- Simple assembly (inner and outer rings are installed separately)
- Rotating parts can be balanced with inner ring installed
- Bearing axial clearance can be defined

GMN Bearing designation

Example

Material	- N HY	Bearings made of bearing steel have no designation Bearings made of high nitrogen steels, special material (on request) Balls and rings made of different materials (HYBRID bearings)
Series	S SM KH	Standard spindle bearings Standard spindle bearings for higher speeds Standard spindle bearings for higher speeds, with seal
Lubrication	- A AB L LB AG	Standard Oil lubrication hole through outer ring on open side Oil lubrication hole through outer ring on closed side Oil lubrication hole through outer ring on open side, outer ring seal with O-rings Oil lubrication hole through outer ring on closed side outer ring seal with O-rings Grease lubrication hole through outer ring on open side
Bearing size	6008	Designation of dimension series and bore diameter
Seal	2RZ	Seal on both sides (for KH series)
Nominal contact angle	C E 18°	15° 25° Special design
Cage	TA TXM	Laminated phenolic resin cage guided in outer ring Plastic cage guided in outer ring, ball-retaining
Precision	P4 P2 A7 A9 HG UP	Tolerance class P4 corresponds to P4S per DIN 628-6 Tolerance class P2 ABEC 7 per ABMA standards, corresponds to P4 ABEC 9 per ABMA standards, corresponds to P2 GMN high precision per GMN specification GMN ultra precision per GMN specification
High point marking	R R _i R _s	Marks the highest point of radial runout (the greatest wall thickness) for inner and outer ring like R, but only for inner ring like R, but only for outer ring
Bearing sets	D T Q	2 bearings 3 bearings 4 bearings
Matching and preload	UL UM US UV B F T	Universal matching – light preload Universal matching – medium preload Universal matching – heavy preload Universal matching – preload per agreement O arrangement X arrangement Tandem arrangement
Lubrication	- L252	ungreased Lubricant identifier, e.g. Turmogrease HS L252

GMN High precision spindle ball bearings Bearing data

Bore diameter 5 to 120 mm

Boundary dimensions

Ball data

Dimensions

Abutment dimensions

Weight

Contact angle

Load rating

Speed values

Preload / axial rigidity

Bearing data

Bore diameter from 5 to 6 mm

Symbol explanations

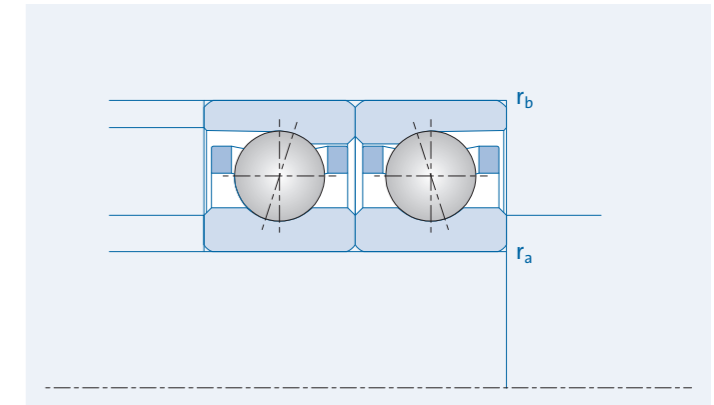
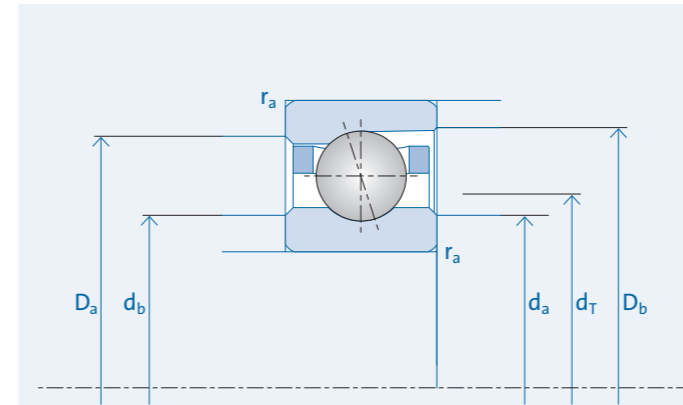
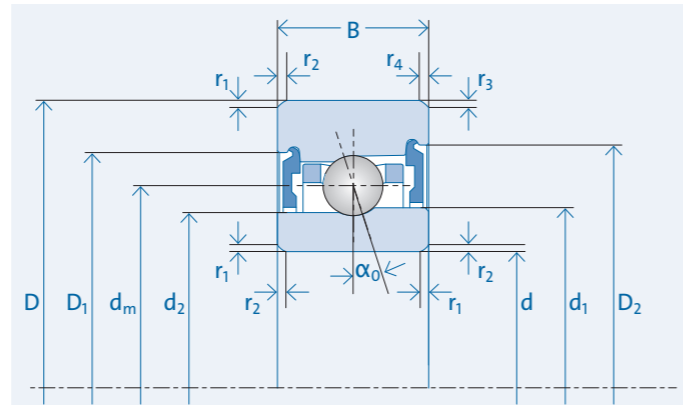
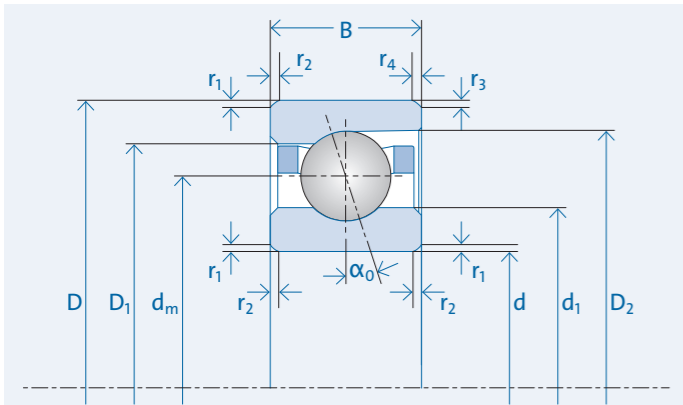

Boundary dimensions

- d** [mm] Bore diameter
- D** [mm] Outer diameter
- B** [mm] Width of single bearing

Balls

- dm** [mm] Pitch circle diameter
- Dw** [mm] Ball diameter
- Z** pieces Number of balls

Dimensions

- d1** [mm] Outer diameter of inner ring
- d2** [mm] Outer diameter of inner ring (open side)

- D1** [mm] Inner diameter of outer ring
- D2** [mm] Inner diameter of outer ring (open side)
- r1,2** [mm] Chamfer (min)
- r3,4** [mm] Chamfer; open side (min)

Abutment dimensions

- ra max** [mm] Undercut of associated component
- rb max** [mm] Undercut of associated component (open side)
- da min** [mm] Abutment diameter inner ring
- db min** [mm] Abutment diameter inner ring
- Da max** [mm] Abutment diameter outer ring

- Db max** [mm] Abutment diameter outer ring
- dT** [mm] Oiling nozzle position for bearings with TA cage (for TXM cage on request)

- m** [kg] Bearing weight
- alpha_0** [°] Contact angle

Load rating

- C** [N] Dynamic load rating
- C0** [N] Static load rating, steel balls
- C0 HY** [N] Static load rating, Si3N4 balls

Speed values

- n_oil** [1/min] Speed with oil lubrication
- n_grease** [1/min] Speed with grease lubrication

Preload / axial rigidity

- Fv** [N] Preload
- Cax** [N/μm] Axial rigidity (bearing pair)
 - L** light preload
 - M** medium preload
 - S** heavy preload
- Ff** [N] Minimum spring preload at max. speed

Designation	Boundary dimensions			Balls			Dimensions							Abutment dimensions				Weight m	Contact angle α ₀	Load rating			Speed value		Preload/axial rigidity						Spring preload F _f	Designation	
	d	D	B	dm	D _w	Z	d ₁	d ₂	D ₁	D ₂	r _{1,2}	r _{3,4}	r _{a max}	r _{b max}	d _{a, b min}	D _{a, b max}	d _T			C	C ₀	C _{0 HY}	n _{oil}	n _{grease}	F _v	C _{ax}	F _v	C _{ax}	F _v	C _{ax}			F _v
5 mm																																	
S 619/5 C TA	5	13	4	9.0	2.381	8	7.1		10.7	11.3	0.2	0.2	0.2	0.1	6.8	11.2	8.05		0.002	15	1200	430	300	190000	140000	6	7	18	11	36	15	35	S 619/5 C TA
S 605 C TA	5	14	5	9.5	2.381	8	6.9		10.3	11.0	0.2	0.2	0.2	0.1	6.5	11.5	7.8		0.004	15	1400	545	385	195000	145000	7	8	20	13	40	20	40	S 605 C TA
SM 605 C TA	5	14	5	9.5	2.381	8	6.9		10.3	11.0	0.2	0.2	0.2	0.1	6.5	11.5	7.8		0.004	15	990	310	216	230000	170000	5	5	14	9	28	13	30	SM 605 C TA
S 625 C TA	5	16	5	10.5	3.175	7	7.7		12.5	13.2	0.3	0.3	0.3	0.15	7.5	13.5	9.0		0.005	15	1930	710	500	170000	125000	10	9	30	14	60	21	50	S 625 C TA
6 mm																																	
S 619/6 C TA	6	15	5	10.5	2.381	9	8.5		12.1	12.7	0.2	0.2	0.2	0.1	8.0	13.0	9.43		0.004	15	1320	510	360	165000	125000	7	8	20	12	40	17	35	S 619/6 C TA
S 606 C TA	6	17	6	10.0	2.381	9	8.3		11.7	12.4	0.3	0.3	0.3	0.1	8.0	14.5	9.2		0.005	15	1540	660	465	170000	125000	8	9	25	16	45	22	40	S 606 C TA
SM 606 C TA	6	17	6	10.0	2.381	9	8.3		11.7	12.4	0.3	0.3	0.3	0.1	8.0	14.5	9.2		0.005	15	1100	370	260	200000	150000	6	7	18	11	32	15	35	SM 606 C TA
S 626 C TA	6	19	6	12.5	3.175	10	10.7		15.8	16.5	0.3	0.3	0.3	0.15	9.0	16.5	12.1		0.008	15	2600	1170	820	125000	94000	15	13	40	20	80	29	70	S 626 C TA

7 to 10 mm



Designation	Boundary dimensions			Balls			Dimensions						Abutment dimensions				Weight m	Contact angle α_0	Load rating			Speed value		Preload/axial rigidity						Spring preload F _f	Designation		
	d	D	B	d _m	D _W	Z	d ₁	d ₂	D ₁	D ₂	r _{1,2}	r _{3,4}	r _{a max}	r _{b max}	d _{a, b min}	D _{a, b max}			d _T	C	C ₀	C _{0 HY}	n _{oil}	n _{grease}	F _V	C _{ax}	F _V	C _{ax}	F _V			C _{ax}	L
7mm																																	
S 619/7 C TA	7	17	5	12.0	2.381	11	10.0		13.6	14.1	0.3	0.3	0.3	0.1	9.0	15.0	10.9		0.005	15	1510	655	460	145000	110000	8	9	23	15	46	21	40	S 619/7 C TA
S 607 C TA	7	19	6	13.0	3.175	10	10.7		15.8	16.5	0.3	0.3	0.3	0.1	9.5	16.5	12.1		0.007	15	2600	1170	820	125000	94000	12	11	40	20	80	30	70	S 607 C TA
SM 607 C TA	7	19	6	13.0	3.175	10	10.7		15.8	16.5	0.3	0.3	0.3	0.1	9.5	16.5	12.1		0.007	15	1920	675	475	150000	110000	10	10	30	15	60	21	60	SM 607 C TA
S 627 C TA	7	22	7	14.5	3.969	9	11.8		17.6	18.6	0.3	0.3	0.3	0.15	10.0	19.0	13.4		0.013	15	3400	1460	1030	115000	86000	20	13	50	19	100	28	90	S 627 C TA
8mm																																	
S 619/8 C TA	8	19	6	13.5	3.175	10	10.7		15.9	16.5	0.3	0.3	0.3	0.1	10.0	17.0	12.2		0.007	15	2600	1170	820	125000	94000	12	12	35	19	70	27	70	S 619/8 C TA
S 608 C TA	8	22	7	15.0	3.969	9	11.8		17.6	18.6	0.3	0.3	0.3	0.1	10.5	19.0	13.4		0.010	15	3400	1460	1030	115000	86000	17	12	50	20	100	28	90	S 608 C TA
SM 608 C TA	8	22	7	15.0	3.969	9	11.8		17.6	18.6	0.3	0.3	0.3	0.1	10.5	19.0	13.4		0.010	15	2700	980	685	136000	100000	13	10	40	16	80	22	85	SM 608 C TA
9mm																																	
S 619/9 C TA	9	20	6	14.5	3.175	11	12.4		17.2	17.9	0.3	0.2	0.3	0.1	11.5	18.0	13.7		0.007	15	2800	1330	940	115000	86000	12	13	40	21	75	29	75	S 619/9 C TA
S 609 C TA	9	24	7	16.5	3.969	10	13.5		19.9	20.6	0.3	0.3	0.3	0.1	11.5	21.0	15.2		0.014	15	3750	1710	1200	102000	76000	20	14	60	24	120	35	100	S 609 C TA
SM 609 C TA	9	24	7	16.5	3.969	10	13.5		19.9	20.6	0.3	0.3	0.3	0.1	11.5	21.0	15.2		0.014	15	2950	1150	810	120000	90000	16	12	50	20	100	27	90	SM 609 C TA
S 629 C TA	9	26	8	17.5	4.762	10	14.7		21.4	22.7	0.3	0.3	0.3	0.15	13.0	23.0	16.5		0.020	15	5450	2600	1830	94000	70000	30	19	80	30	160	42	140	S 629 C TA
10mm																																	
S 61800 C TA	10	19	5	14.5	2.381	13	12.8		16.2	16.9	0.3	0.2	0.3	0.15	12.0	17.0	13.6		0.005	15	1660	830	580	115000	86000	8	10	25	17	50	23	45	S 61800 C TA
S 61800 E TA	10	19	5	14.5	2.381	13	12.8		16.2	16.9	0.3	0.2	0.3	0.15	12.0	17.0	13.6		0.005	25	1500	725	510	100000	75000	13	25	40	39	80	51	55	S 61800 E TA
S 61900 C TA	10	22	6	16.0	3.175	11	13.6		17.8	18.8	0.3	0.3	0.3	0.1	12.5	19.5	14.7		0.010	15	2800	1360	960	110000	82000	12	13	40	21	75	29	75	S 61900 C TA
S 61900 E TA	10	22	6	16.0	3.175	11	13.6		17.8	18.8	0.3	0.3	0.3	0.1	12.5	19.5	14.7		0.010	25	2700	1300	920	92000	69000	22	32	70	50	140	65	100	S 61900 E TA
SM 61900 C TA	10	22	6	16.0	3.175	11	13.6		17.8	18.8	0.3	0.3	0.3	0.1	12.5	19.5	14.7		0.010	15	2080	810	565	125000	94000	11	11	30	16	65	23	65	SM 61900 C TA
KH 61900 C TA	10	22	6	16.0	2.381	14	13.6	13.3	17.8	18.5	0.3	0.3	0.3	0.1	12.5	19.5	14.5		0.010	17	1420	590	415	135000	100000	7	12	21	18	45	25	55	KH 61900 C TA
KH 61900 E TA	10	22	6	16.0	2.381	14	13.6	13.3	17.8	18.5	0.3	0.3	0.3	0.1	12.5	19.5	14.5		0.010	25	1360	565	400	125000	94000	11	25	35	37	70	49	65	KH 61900 E TA
S 6000 C TA	10	26	8	18.0	4.762	10	14.7		21.4	22.7	0.3	0.3	0.3	0.1	12.5	23.0	16.5		0.018	15	5450	2600	1830	95000	71000	25	17	80	30	160	43	140	S 6000 C TA
S 6000 E TA	10	26	8	18.0	4.762	10	14.7		21.4	22.7	0.3	0.3	0.3	0.1	12.5	23.0	16.5		0.018	25	5250	2550	1760	80000	60000	45	42	130	65	260	87	195	S 6000 E TA
SM 6000 C TA	10	26	8	18.0	4.762	10	14.7		21.4	22.7	0.3	0.3	0.3	0.1	12.5	23.0	16.5		0.018	15	3950	1530	1070	111000	83000	18	13	60	22	110	29	120	SM 6000 C TA
KH 6000 C TA	10	26	8	18.0	3.175	11	14.7	14.2	20.5	21.3	0.3	0.3	0.3	0.1	12.5	23.0	15.9		0.018	17	2020	780	550	125000	94000	10	12	30	19	60	26	75	KH 6000 C TA
KH 6000 E TA	10	26	8	18.0	3.175	11	14.7	14.2	20.5	21.3	0.3	0.3	0.3	0.1	12.5	23.0	15.9		0.018	25	1950	750	530	110000	82000	16	26	50	39	100	51	95	KH 6000 E TA
S 6200 C TA	10	30	9	20.0	5.556	10	16.0		24.5	25.5	0.6	0.6	0.6	0.3	14.5	25.5	18.3		0.030	15	7500	3750	2650	85000	64000	40	23	120	39	230	54	195	S 6200 C TA
S 6200 E TA	10	30	9	20.0	5.556	10	16.0		24.5	25.5	0.6	0.6	0.6	0.3	14.5	25.5	18.3		0.030	25	7250	3600	2550	72000	54000	60	54	180	81	360	110	265	S 6200 E TA

12 to 15 mm



Designation	Boundary dimensions			Balls			Dimensions						Abutment dimensions				Weight m	Contact angle α_0	Load rating			Speed value		Preload/axial rigidity						Spring preload F _f	Designation		
	d	D	B	d _m	D _W	Z	d ₁	d ₂	D ₁	D ₂	r _{1,2}	r _{3,4}	r _{a max}	r _{b max}	d _{a, b min}	D _{a, b max}			d _T	C	C ₀	C _{0 HY}	n _{oil}	n _{grease}	F _V	C _{ax}	F _V	C _{ax}	F _V			C _{ax}	L
12 mm															12 mm																		
S 61801 C TA	12	21	5	16.5	2.381	15	14.6		18.0	18.6	0.3	0.2	0.3	0.15	14.0	19.0	15.4		0.006	15	1800	980	685	105000	79000	9	12	25	18	55	26	50	S 61801 C TA
S 61801 E TA	12	21	5	16.5	2.381	15	14.6		18.0	18.6	0.3	0.2	0.3	0.15	14.0	19.0	15.4		0.006	25	1710	930	650	89000	67000	15	29	45	44	90	58	65	S 61801 E TA
S 61901 C TA	12	24	6	18.0	3.175	13	15.4		19.6	20.6	0.3	0.3	0.3	0.1	14.5	21.5	16.5		0.011	15	3100	1660	1170	97000	73000	15	15	43	24	85	34	80	S 61901 C TA
S 61901 E TA	12	24	6	18.0	3.175	13	15.4		19.6	20.6	0.3	0.3	0.3	0.1	14.5	21.5	16.5		0.011	25	2950	1580	1110	83000	62000	25	37	75	56	150	74	110	S 61901 E TA
SM 61901 C TA	12	24	6	18.0	3.175	13	15.4		19.6	20.6	0.3	0.3	0.3	0.1	14.5	21.5	16.5		0.011	15	2330	990	695	115000	86000	12	13	35	19	70	26	70	SM 61901 C TA
KH 61901 C TA	12	24	6	18.0	2.381	15	15.4	15.1	19.6	20.3	0.3	0.3	0.3	0.1	14.5	21.5	16.3		0.011	17	1480	650	455	120000	90000	7	12	22	19	45	26	55	KH 61901 C TA
KH 61901 E TA	12	24	6	18.0	2.381	15	15.4	15.1	19.6	20.3	0.3	0.3	0.3	0.1	14.5	21.5	16.3		0.011	25	1410	620	440	110000	82000	12	26	35	39	70	51	70	KH 61901 E TA
S 6001 C TA	12	28	8	20.0	4.762	11	16.7		23.4	24.7	0.3	0.3	0.3	0.1	14.5	25.0	18.5		0.020	15	5900	3000	2100	85000	64000	30	20	90	33	180	48	155	S 6001 C TA
S 6001 E TA	12	28	8	20.0	4.762	11	16.7		23.4	24.7	0.3	0.3	0.3	0.1	14.5	25.0	18.5		0.020	25	5650	2900	2020	72500	54000	50	47	140	70	280	95	205	S 6001 E TA
SM 6001 C TA	12	28	8	20.0	4.762	11	16.7		23.4	24.7	0.3	0.3	0.3	0.1	14.5	25.0	18.5		0.020	15	4300	1750	1230	100000	75000	22	15	65	24	130	33	130	SM 6001 C TA
KH 6001 C TA	12	28	8	19.0	3.175	13	16.7	16.2	22.5	23.3	0.3	0.3	0.3	0.1	14.5	25.0	18.0		0.020	17	2260	950	670	110000	82000	11	15	35	22	70	30	85	KH 6001 C TA
KH 6001 E TA	12	28	8	19.0	3.175	13	16.7	16.2	22.5	23.3	0.3	0.3	0.3	0.1	14.5	25.0	18.0		0.020	25	2180	920	645	100000	75000	18	30	55	45	110	59	105	KH 6001 E TA
S 6201 C TA	12	32	10	22.0	5.953	10	18.3		26.0	27.9	0.6	0.6	0.6	0.3	16.5	27.5	20.5		0.037	15	8300	4150	2950	77000	58000	42	23	130	39	250	54	215	S 6201 C TA
S 6201 E TA	12	32	10	22.0	5.953	10	18.3		26.0	27.9	0.6	0.6	0.6	0.3	16.5	27.5	20.5		0.037	25	8000	4050	2850	66000	49000	70	56	200	84	400	112	290	S 6201 E TA
15 mm															15 mm																		
S 61802 C TA	15	24	5	19.5	2.381	17	17.8		21.2	21.8	0.3	0.2	0.3	0.15	17.0	22.0	18.6		0.007	15	1900	1150	810	87000	65000	10	13	30	21	60	29	50	S 61802 C TA
S 61802 E TA	15	24	5	19.5	2.381	17	17.8		21.2	21.8	0.3	0.2	0.3	0.15	17.0	22.0	18.6		0.007	25	1790	1090	770	74000	55000	15	32	45	48	90	62	65	S 61802 E TA
S 61902 C TA	15	28	7	21.5	3.969	13	18.7		24.3	25.4	0.3	0.3	0.3	0.1	17.5	25.5	20.2		0.015	15	4500	2450	1720	79000	59000	22	18	70	29	140	42	115	S 61902 C TA
S 61902 E TA	15	28	7	21.5	3.969	13	18.7		24.3	25.4	0.3	0.3	0.3	0.1	17.5	25.5	20.2		0.015	25	4300	2330	1640	67000	50000	35	44	110	68	220	89	160	S 61902 E TA
SM 61902 C TA	15	28	7	21.5	3.969	13	18.7		24.3	25.4	0.3	0.3	0.3	0.1	17.5	25.5	20.2		0.015	15	3600	1560	1100	93000	70000	18	15	55	24	110	33	110	SM 61902 C TA
KH 61902 C TA	15	28	7	21.5	2.778	16	18.7	18.3	23.9	24.5	0.3	0.3	0.3	0.1	17.5	25.5	19.9		0.015	17	2010	940	660	100000	75000	10	15	30	23	60	31	75	KH 61902 C TA
KH 61902 E TA	15	28	7	21.5	2.778	16	18.7	18.3	23.9	24.5	0.3	0.3	0.3	0.1	17.5	25.5	19.9		0.015	25	1930	900	630	90000	67000	16	32	50	48	100	64	95	KH 61902 E TA
S 6002 C TA	15	32	9	23.5	4.762	13	20.2		26.9	28.2	0.3	0.3	0.3	0.1	17.5	29.0	21.9		0.028	15	6650	3750	2650	72000	54000	32	22	100	38	200	55	170	S 6002 C TA
S 6002 E TA	15	32	9	23.5	4.762	13	20.2		26.9	28.2	0.3	0.3	0.3	0.1	17.5	29.0	21.9		0.028	25	6350	3600	2550	62000	46000	55	54	160	82	320	110	235	S 6002 E TA
SM 6002 C TA	15	32	9	23.5	4.762	13	20.2		26.9	28.2	0.3	0.3	0.3	0.1	17.5	29.0	21.9		0.028	15	4900	2140	1510	85000	64000	22	17	75	28	150	38	150	SM 6002 C TA
KH 6002 C TA	15	32	9	23.5	3.969	13	20.2	19.4	26.7	28.0	0.3	0.3	0.3	0.1	17.5	29.0	21.6		0.028	17	3400	1470	1040	92000	69000	17	18	50	27	100	36	125	KH 6002 C TA
KH 6002 E TA	15	32	9	23.5	3.969	13	20.2	19.4	26.7	28.0	0.3	0.3	0.3	0.1	17.5	29.0	21.6		0.028	25	3300	1420	1000	83000	62000	30	39	80	55	160	72	160	KH 6002 E TA
S 6202 C TA	15	35	11	25.0	5.953	11	21.1		29.0	31.3	0.6	0.3	0.6	0.3	19.5	30.5	23.4		0.044	15	9000	4850	3450	67000	50000	45	25	130	41	270	59	230	S 6202 C TA
S 6202 E TA	15	35	11	25.0	5.953	11	21.1		29.0	31.3	0.6	0.3	0.6	0.3	19.5	30.5	23.4		0.044	25	8700	4700	3300	57000	43000	75	61	220	93	440	123	320	S 6202 E TA

17 to 20 mm



Designation	Boundary dimensions			Balls			Dimensions						Abutment dimensions				Weight m	Contact angle α_0	Load rating			Speed value		Preload/axial rigidity						Spring preload F _f	Designation		
	d	D	B	d _m	D _W	Z	d ₁	d ₂	D ₁	D ₂	r _{1,2}	r _{3,4}	r _{a max}	r _{b max}	d _{a, b min}	D _{a, b max}			d _T	C	C ₀	C _{0 HY}	n _{oil}	n _{grease}	L		M		S				
17mm																	17mm																
S 61803 C TA	17	26	5	21.5	2.381	19	19.8		23.2	23.8	0.3	0.2	0.3	0.15	19.0	24.0	20.6		0.008	15	2000	1310	920	79000	59000	10	14	30	22	60	31	55	S 61803 C TA
S 61803 E TA	17	26	5	21.5	2.381	19	19.8		23.2	23.8	0.3	0.2	0.3	0.15	19.0	24.0	20.6		0.008	25	1890	1240	870	67000	50000	16	35	50	54	100	69	70	S 61803 E TA
S 61903 C TA	17	30	7	23.5	3.969	14	21.0		26.6	27.7	0.3	0.3	0.3	0.1	19.5	27.5	22.5		0.017	15	4700	2700	1900	71000	53000	25	20	75	32	150	45	120	S 61903 C TA
S 61903 E TA	17	30	7	23.5	3.969	14	21.0		26.6	27.7	0.3	0.3	0.3	0.1	19.5	27.5	22.5		0.017	25	4450	2600	1810	61000	46000	40	49	120	73	240	96	165	S 61903 E TA
SM 61903 C TA	17	30	7	23.5	3.969	14	21.0		26.6	27.7	0.3	0.3	0.3	0.1	19.5	27.5	22.5		0.017	15	3750	1750	1230	84000	63000	19	16	55	25	110	34	115	SM 61903 C TA
KH 61903 C TA	17	30	7	23.5	2.778	18	21.0	20.6	26.2	26.8	0.3	0.3	0.3	0.1	19.5	27.5	22.2		0.017	17	2150	1070	760	90000	67000	11	17	35	27	65	34	80	KH 61903 C TA
KH 61903 E TA	17	30	7	23.5	2.778	18	21.0	20.6	26.2	26.8	0.3	0.3	0.3	0.1	19.5	27.5	22.2		0.017	25	2060	1020	720	82000	61000	17	35	50	62	100	67	100	KH 61903 E TA
S 6003 C TA	17	35	10	26.0	4.762	14	22.7		29.4	30.7	0.3	0.3	0.3	0.1	20.0	31.5	24.4		0.037	15	6950	4150	2950	65000	49000	35	24	105	41	210	59	180	S 6003 C TA
S 6003 E TA	17	35	10	26.0	4.762	14	22.7		29.4	30.7	0.3	0.3	0.3	0.1	20.0	31.5	24.4		0.037	25	6650	4000	2800	56000	42000	60	58	170	88	340	115	245	S 6003 E TA
SM 6003 C TA	17	35	10	26.0	4.762	14	22.7		29.4	30.7	0.3	0.3	0.3	0.1	20.0	31.5	24.4		0.037	15	5150	2410	1690	77000	58000	25	19	80	30	160	41	155	SM 6003 C TA
KH 6003 C TA	17	35	10	26.0	3.969	15	22.7	22	29.8	30.4	0.3	0.3	0.3	0.1	20.0	31.5	24.2		0.037	17	3750	1750	1230	82000	61000	19	20	55	31	110	41	135	KH 6003 C TA
KH 6003 E TA	17	35	10	26.0	3.969	15	22.7	22	29.8	30.4	0.3	0.3	0.3	0.1	20.0	31.5	24.2		0.037	25	3600	1680	1180	74000	55000	30	42	90	63	180	82	175	KH 6003 E TA
S 6203 C TA	17	40	12	28.5	6.747	11	24.1		33.0	35.2	0.6	0.3	0.6	0.3	21.5	35.0	26.6		0.065	15	11400	6350	4450	60000	45000	60	29	170	48	350	69	295	S 6203 C TA
S 6203 E TA	17	40	12	28.5	6.747	11	24.1		33.0	35.2	0.6	0.3	0.6	0.3	21.5	35.0	26.6		0.065	25	11000	6100	4300	51000	38000	90	69	280	106	560	143	400	S 6203 E TA
20mm																	20mm																
S 61804 C TA	20	32	7	26.0	3.175	18	23.9		28.1	29.1	0.3	0.3	0.3	0.15	23.0	29.0	24.9		0.018	15	3650	2500	1760	65000	49000	19	21	55	32	110	45	95	S 61804 C TA
S 61804 E TA	20	32	7	26.0	3.175	18	23.9		28.1	29.1	0.3	0.3	0.3	0.15	23.0	29.0	24.9		0.018	25	3450	2380	1680	56000	42000	30	49	90	74	170	95	130	S 61804 E TA
S 61904 C TA	20	37	9	28.5	4.762	15	25.1		31.9	33.2	0.3	0.3	0.3	0.15	23.0	33.5	26.9		0.036	15	7250	4600	3200	60000	45000	35	26	110	43	220	61	185	S 61904 C TA
S 61904 E TA	20	37	9	28.5	4.762	15	25.1		31.9	33.2	0.3	0.3	0.3	0.15	23.0	33.5	26.9		0.036	25	6850	4350	3050	51000	38000	55	62	170	95	340	125	250	S 61904 E TA
SM 61904 C TA	20	37	9	28.5	4.762	15	25.1		31.9	33.2	0.3	0.3	0.3	0.15	23.0	33.5	26.9		0.036	15	5400	2700	1870	70000	52000	30	22	80	32	170	45	165	SM 61904 C TA
KH 61904 C TA	20	37	9	28.5	3.969	16	25.1	24.5	31.7	33.0	0.3	0.3	0.3	0.15	23.0	33.5	26.6		0.036	17	3900	1900	1340	75000	56000	20	21	60	33	120	44	140	KH 61904 C TA
KH 61904 E TA	20	37	9	28.5	3.969	16	25.1	24.5	31.7	33.0	0.3	0.3	0.3	0.15	23.0	33.5	26.6		0.036	25	3700	1820	1280	68000	51000	30	44	90	66	180	85	180	KH 61904 E TA
S 6004 C TA	20	42	12	31.0	6.35	13	26.6		35.5	37.3	0.6	0.3	0.6	0.3	25.0	37.0	29.0		0.063	15	12200	7600	5350	55000	41000	60	33	180	57	360	84	315	S 6004 C TA
S 6004 E TA	20	42	12	31.0	6.35	13	26.6		35.5	37.3	0.6	0.3	0.6	0.3	25.0	37.0	29.0		0.063	25	11700	7300	5150	47000	35000	100	78	300	120	600	165	425	S 6004 E TA
SM 6004 C TA	20	42	12	31.0	6.35	13	26.6		35.5	37.3	0.6	0.3	0.6	0.3	25.0	37.0	29.0		0.063	15	8300	3800	2700	65000	49000	40	24	120	37	240	51	250	SM 6004 C TA
KH 6004 C TA	20	42	12	31.0	5.556	14	26.6	25.3	36.4	38.0	0.6	0.3	0.6	0.3	25.0	37.0	28.6		0.063	17	6500	3050	2140	70000	52000	35	27	100	40	200	54	235	KH 6004 C TA
KH 6004 E TA	20	42	12	31.0	5.556	14	26.6	25.3	36.4	38.0	0.6	0.3	0.6	0.3	25.0	37.0	28.6		0.063	25	6300	2950	2060	63000	47000	50	54	160	82	320	106	300	KH 6004 E TA
S 6204 C TA	20	47	14	33.5	7.938	11	28.5		38.6	41.4	1.0	0.6	1.0	0.6	26.0	41.0	31.4		0.105	15	16900	10000	7050	51000	38000	85	38	260	66	500	94	435	S 6204 C TA
S 6204 E TA	20	47	14	33.5	7.938	11	28.5		38.6	41.4	1.0	0.6	1.0	0.6	26.0	41.0	31.4		0.105	25	16200	9800	6850	43000	32000	140	91	410	139	820	189	590	S 6204 E TA

25 to 30 mm

Designation	Boundary dimensions			Balls			Dimensions					Abutment dimensions				Weight	Contact angle	Load rating			Speed value		Preload/axial rigidity						Spring preload	Designation					
	d	D	B	d _m	D _w	Z	d ₁	d ₂	D ₁	D ₂	r _{1,2}	r _{3,4}	r _{a max}	r _{b max}	d _{a, b min}			D _{a, b max}	d _T	m	α ₀	C	C ₀	C _{0 HY}	n _{oil}	n _{grease}	F _v	C _{ax}			F _v	C _{ax}	F _v	C _{ax}	F _f
25 mm																		25 mm																	
S 61805 C TA	25	37	7	31.0	3.175	19	28.9		33.1	34.1	0.3	0.3	0.3	0.15	28.0	34.0	29.9	0.021	15	3650	2750	1930	55000	41000	19	21	55	33	110	46	95	S 61805 C TA			
S 61805 E TA	25	37	7	31.0	3.175	19	28.9		33.1	34.1	0.3	0.3	0.3	0.15	28.0	34.0	29.9	0.021	25	3450	2600	1830	47000	35000	30	51	90	76	170	98	130	S 61805 E TA			
S 61905 C TA	25	42	9	33.5	4.762	17	30.6		37.4	38.7	0.3	0.3	0.3	0.15	28.0	38.5	32.4	0.041	15	7700	5400	3800	50000	37000	40	29	120	48	240	67	200	S 61905 C TA			
S 61905 E TA	25	42	9	33.5	4.762	17	30.6		37.4	38.7	0.3	0.3	0.3	0.15	28.0	38.5	32.4	0.041	25	7300	5100	3600	43000	32000	60	70	180	105	360	138	265	S 61905 E TA			
SM 61905 C TA	25	42	9	33.5	4.762	17	30.6		37.4	38.7	0.3	0.3	0.3	0.15	28.0	38.5	32.4	0.041	15	5800	3150	2200	59000	44000	30	23	90	36	180	49	175	SM 61905 C TA			
KH 61905 C TA	25	42	9	33.5	3.969	19	30.6	30	37.2	38.5	0.3	0.3	0.3	0.15	28.0	38.5	32.1	0.041	17	4250	2330	1640	63000	47000	22	25	65	38	130	51	155	KH 61905 C TA			
KH 61905 E TA	25	42	9	33.5	3.969	19	30.6	30	37.2	38.5	0.3	0.3	0.3	0.15	28.0	38.5	32.1	0.041	25	4100	2220	1560	57000	43000	35	52	100	76	200	99	195	KH 61905 E TA			
S 6005 C TA	25	47	12	36.0	6.35	15	32.2		40.1	42.3	0.6	0.3	0.6	0.3	30.0	42.0	34.3	0.076	15	13400	9200	6500	47000	35000	70	38	200	65	400	95	345	S 6005 C TA			
S 6005 E TA	25	47	12	36.0	6.35	15	32.2		40.1	42.3	0.6	0.3	0.6	0.3	30.0	42.0	34.3	0.076	25	12700	8800	6200	40000	30000	110	88	320	135	640	180	465	S 6005 E TA			
SM 6005 C TA	25	47	12	36.0	6.35	15	32.2		40.1	42.3	0.6	0.3	0.6	0.3	30.0	42.0	34.3	0.076	15	9200	4700	3300	55000	41000	50	28	140	43	280	59	280	SM 6005 C TA			
KH 6005 C TA	25	47	12	36.0	5.556	17	32.2	30.9	42.0	43.6	0.6	0.3	0.6	0.3	30.0	42.0	34.2	0.076	17	7400	3900	2750	59000	44000	35	30	110	47	220	63	265	KH 6005 C TA			
KH 6005 E TA	25	47	12	36.0	5.556	17	32.2	30.9	42.0	43.6	0.6	0.3	0.6	0.3	30.0	42.0	34.2	0.076	25	7100	3750	2650	53000	40000	60	65	180	96	360	125	340	KH 6005 E TA			
S 6205 C TA	25	52	15	38.5	7.938	13	34.0		44.1	46.9	1.0	0.6	1.0	0.6	31.0	46.0	36.8	0.128	15	19000	12600	8900	44000	33000	100	45	300	77	600	112	485	S 6205 C TA			
S 6205 E TA	25	52	15	38.5	7.938	13	34.0		44.1	46.9	1.0	0.6	1.0	0.6	31.0	46.0	36.8	0.128	25	18200	12000	8400	37000	27500	150	104	450	159	900	216	660	S 6205 E TA			
30 mm																		30 mm																	
S 61806 C TA	30	42	7	36.0	3.175	22	34.1		38.3	39.3	0.3	0.3	0.3	0.15	33.0	39.0	35.1	0.025	15	3850	3250	2280	47000	35000	20	24	60	37	120	52	100	S 61806 C TA			
S 61806 E TA	30	42	7	36.0	3.175	22	34.1		38.3	39.3	0.3	0.3	0.3	0.15	33.0	39.0	35.1	0.025	25	3650	3100	2150	40000	30000	30	56	90	76	180	109	135	S 61806 E TA			
S 61906 C TA	30	47	9	38.5	4.762	18	35.1		41.9	43.2	0.3	0.3	0.3	0.15	33.0	43.5	36.8	0.047	15	7800	5850	4100	44000	33000	40	30	120	50	240	69	200	S 61906 C TA			
S 61906 E TA	30	47	9	38.5	4.762	18	35.1		41.9	43.2	0.3	0.3	0.3	0.15	33.0	43.5	36.8	0.047	25	7400	5550	3900	38000	28500	60	72	190	111	380	146	270	S 61906 E TA			
SM 61906 C TA	30	47	9	38.5	4.762	18	35.1		41.9	43.2	0.3	0.3	0.3	0.15	33.0	43.5	36.8	0.047	15	5950	3400	2380	52000	39000	30	24	90	37	180	50	180	SM 61906 C TA			
KH 61906 C TA	30	47	9	38.5	3.969	22	35.1	35	41.7	43.0	0.3	0.3	0.3	0.15	33.0	43.5	36.5	0.047	17	4650	2750	1930	55000	41000	23	28	70	43	140	57	170	KH 61906 C TA			
KH 61906 E TA	30	47	9	38.5	3.969	22	35.1	35	41.7	43.0	0.3	0.3	0.3	0.15	33.0	43.5	36.5	0.047	25	4400	2650	1840	50000	37000	35	58	110	87	220	112	210	KH 61906 E TA			
S 6006 C TA	30	55	13	42.5	7.144	16	38.1		47.0	49.5	1.0	0.6	1.0	0.3	36.0	49.0	40.5	0.112	15	16500	11900	8400	40000	30000	85	43	250	72	500	105	425	S 6006 C TA			
S 6006 E TA	30	55	13	42.5	7.144	16	38.1		47.0	49.5	1.0	0.6	1.0	0.3	36.0	49.0	40.5	0.112	25	15700	11400	8000	34000	25500	130	98	400	150	800	205	570	S 6006 E TA			
SM 6006 C TA	30	55	13	42.5	7.144	16	38.1		47.0	49.5	1.0	0.6	1.0	0.3	36.0	49.0	40.5	0.112	15	11900	6450	4550	47000	35000	60	32	180	50	360	69	360	SM 6006 C TA			
KH 6006 C TA	30	55	13	42.5	5.556	20	38.1	37	47.9	49.5	1.0	0.6	1.0	0.3	36.0	49.0	40.1	0.112	17	8200	4700	3350	50000	37000	40	35	120	54	250	73	295	KH 6006 C TA			
KH 6006 E TA	30	55	13	42.5	5.556	20	38.1	37	47.9	49.5	1.0	0.6	1.0	0.3	36.0	49.0	40.1	0.112	25	7800	4500	3200	46000	34000	65	74	200	111	390	143	375	KH 6006 E TA			
S 6206 C TA	30	62	16	46.0	9.525	13	40.4		52.1	55.4	1.0	0.6	1.0	0.6	36.0	55.0	43.6	0.199	15	25000	16700	11800	37000	27500	130	49	380	82	760	117	640	S 6206 C TA			
S 6206 E TA	30	62	16	46.0	9.525	13	40.4		52.1	55.4	1.0	0.6	1.0	0.6	36.0	55.0	43.6	0.199	25	24000	16100	11300	32000	24000	200	117	600	177	1200	239	880	S 6206 E TA			

35 to 40 mm

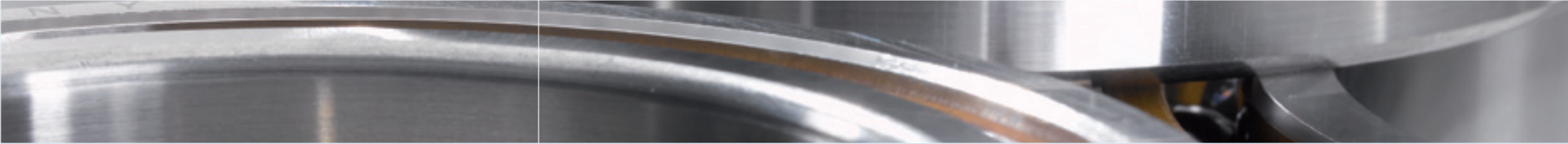

Designation	Boundary dimensions			Balls			Dimensions						Abutment dimensions				Weight m	Contact angle α ₀	Load rating			Speed value		Preload/axial rigidity						Spring preload F _f	Designation																						
	d	D	B	d _m	D _W	Z	d ₁	d ₂	D ₁	D ₂	r _{1,2}	r _{3,4}	r _{a max}	r _{b max}	d _{a, b min}	D _{a, b max}			d _T	C	C ₀	C _{0 HY}	n _{oil}	n _{grease}	L		M		S																								
35 mm																											35 mm																										
S 61807 C TA	35	47	7	41.0	3.175	24	38.9		43.1	44.1	0.3	0.3	0.3	0.15	38.0	44.0	39.9		0.028	15	3950	3600	2550	41000	31000	20	25	60	39	120	54	105	S 61807 C TA																				
S 61807 E TA	35	47	7	41.0	3.175	24	38.9		43.1	44.1	0.3	0.3	0.3	0.15	38.0	44.0	39.9		0.028	25	3750	3400	2370	35000	26000	30	58	90	93	190	118	140	S 61807 E TA																				
S 61907 C TA	35	55	10	45.0	5.556	18	41.4		48.6	50.4	0.6	0.3	0.6	0.15	40.0	50.5	43.3		0.075	15	10900	8700	6100	38000	28500	55	37	165	61	330	86	280	S 61907 C TA																				
S 61907 E TA	35	55	10	45.0	5.556	18	41.4		48.6	50.4	0.6	0.3	0.6	0.15	40.0	50.5	43.3		0.075	25	10300	8200	5750	32000	24000	90	91	260	135	520	177	375	S 61907 E TA																				
SM 61907 C TA	35	55	10	45.0	5.556	18	41.4		48.6	50.4	0.6	0.3	0.6	0.15	40.0	50.5	43.3		0.075	17	8000	4750	3350	44000	33000	40	34	120	52	240	69	275	SM 61907 C TA																				
KH 61907 C TA	35	55	10	45.0	3.969	26	41.4	40.8	48.1	49.4	0.6	0.3	0.6	0.15	40.0	50.5	43.0		0.075	17	5050	3300	2320	47000	35000	25	32	80	50	150	64	185	KH 61907 C TA																				
KH 61907 E TA	35	55	10	45.0	3.969	26	41.4	40.8	48.1	49.4	0.6	0.3	0.6	0.15	40.0	50.5	43.0		0.075	25	4800	3150	2210	43000	32000	40	67	120	99	240	129	230	KH 61907 E TA																				
S 6007 C TA	35	62	14	48.5	7.938	16	43.2		53.1	56.3	1.0	0.6	1.0	0.3	41.0	56.0	46.1		0.149	15	20600	15500	10900	35000	26000	100	50	300	84	600	120	530	S 6007 C TA																				
S 6007 E TA	35	62	14	48.5	7.938	16	43.2		53.1	56.3	1.0	0.6	1.0	0.3	41.0	56.0	46.1		0.149	25	19600	14800	10400	30000	22500	170	118	500	180	1000	245	715	S 6007 E TA																				
SM 6007 C TA	35	62	14	48.5	7.938	16	43.2		53.1	56.3	1.0	0.6	1.0	0.3	41.0	56.0	46.1		0.149	15	14300	8000	5650	41000	31000	70	37	210	57	420	77	430	SM 6007 C TA																				
KH 6007 C TA	35	62	14	48.5	6.35	20	43.2	41.5	53.6	56.0	1.0	0.6	1.0	0.3	41.0	56.0	45.5		0.149	17	10400	6150	4350	44000	33000	50	40	160	62	320	82	375	KH 6007 C TA																				
KH 6007 E TA	35	62	14	48.5	6.35	20	43.2	41.5	53.6	56.0	1.0	0.6	1.0	0.3	41.0	56.0	45.5		0.149	25	10000	5900	4150	40000	30000	80	83	250	125	500	162	480	KH 6007 E TA																				
S 6207 C TA	35	72	17	53.5	11.112	13	47.4		60.6	64.5	1.1	0.6	1.0	0.6	43.0	64.0	50.9		0.290	15	35000	24300	17100	32000	24000	180	60	530	102	1000	142	900	S 6207 C TA																				
S 6207 E TA	35	72	17	53.5	11.112	13	47.4		60.6	64.5	1.1	0.6	1.0	0.6	43.0	64.0	50.9		0.290	25	33500	23200	16300	27000	20000	280	142	840	217	1700	296	1220	S 6207 E TA																				
40 mm																											40 mm																										
S 61808 C TA	40	52	7	46.0	3.175	26	43.9		48.1	49.1	0.3	0.3	0.3	0.15	43.0	49.0	44.9		0.031	15	4050	3950	2750	37000	27500	21	27	60	41	120	57	105	S 61808 C TA																				
S 61808 E TA	40	52	7	46.0	3.175	26	43.9		48.1	49.1	0.3	0.3	0.3	0.15	43.0	49.0	44.9		0.031	25	3800	3700	2600	32000	24000	30	62	100	97	190	124	140	S 61808 E TA																				
S 61908 C TA	40	62	12	51.0	6.35	19	46.8		55.2	57.2	0.6	0.3	0.6	0.15	45.0	57.5	49.0		0.109	15	14900	12700	9000	33000	24500	75	46	230	77	460	109	380	S 61908 C TA																				
S 61908 E TA	40	62	12	51.0	6.35	19	46.8		55.2	57.2	0.6	0.3	0.6	0.15	45.0	57.5	49.0		0.109	25	14100	12100	8500	28500	21500	120	111	360	168	720	225	515	S 61908 E TA																				
SM 61908 C TA	40	62	12	51.0	6.35	19	46.8		55.2	57.2	0.6	0.3	0.6	0.15	45.0	57.5	49.0		0.109	17	10400	6350	4500	39000	29000	55	41	160	62	320	83	355	SM 61908 C TA																				
KH 61908 C TA	40	62	12	51.0	4.762	25	46.8	45.3	55.2	56.7	0.6	0.3	0.6	0.15	45.0	57.5	48.3		0.109	17	6850	4550	3200	42000	31000	35	37	100	55	210	75	245	KH 61908 C TA																				
KH 61908 E TA	40	62	12	51.0	4.762	25	46.8	45.3	55.2	56.7	0.6	0.3	0.6	0.15	45.0	57.5	48.3		0.109	25	6550	4300	3050	38000	28500	55	77	160	113	330	148	315	KH 61908 E TA																				
S 6008 C TA	40	68	15	54.0	7.938	18	49.2		59.0	61.8	1.0	0.6	1.0	0.3	46.0	62.0	51.8		0.185	15	22000	17900	12600	31500	23500	110	53	330	91	660	130	565	S 6008 C TA																				
S 6008 E TA	40	68	15	54.0	7.938	18	49.2		59.0	61.8	1.0	0.6	1.0	0.3	46.0	62.0	51.8		0.185	25	20900	17100	12000	27000	20000	180	125	530	190	1100	265	760	S 6008 E TA																				
SM 6008 C TA	40	68	15	54.0	7.938	18	49.2		59.0	61.8	1.0	0.6	1.0	0.3	46.0	62.0	51.8		0.185	15	15400	9300	6500	37000	27500	80	40	230	61	460	83	465	SM 6008 C TA																				
KH 6008 C TA	40	68	15	54.0	6.35	22	49.2	47.5	60.2	62.6	1.0	0.6	1.0	0.3	46.0	62.0	51.4		0.185	17	10900	6900	4850	39000	29000	55	44	160	65	330	88	390	KH 6008 C TA																				
KH 6008 E TA	40	68	15	54.0	6.35	22	49.2	47.5	60.2	62.6	1.0	0.6	1.0	0.3	46.0	62.0	51.4		0.185	25	10500	6550	4650	36000	27000	90	92	260	135	520	175	500	KH 6008 E TA																				
S 6208 C TA	40	80	18	60.0	11.906	13	52.8		67.6	71.8	1.1	0.6	1.0	0.6	48.0	72.0	56.9		0.368	15	36500	25500	17900	28500	21500	185	58	560	98	1100	137	940	S 6208 C TA																				
S 6208 E TA	40	80	18	60.0	11.906	13	52.8		67.6	71.8	1.1	0.6	1.0	0.6	48.0	72.0	56.9		0.368	25	35000	24400	17200	24000	18000	300	142	900	215	1800	288	1270	S 6208 E TA																				

45 to 50 mm

Designation	Boundary dimensions			Balls			Dimensions						Abutment dimensions				Weight m	Contact angle α_0	Load rating			Speed value		Preload/axial rigidity						Spring preload F _f	Designation																									
	d	D	B	d _m	D _W	Z	d ₁	d ₂	D ₁	D ₂	r _{1,2}	r _{3,4}	r _{a max}	r _{b max}	d _{a, b min}	D _{a, b max}			d _T	C	C ₀	C _{0 HY}	n _{oil}	n _{grease}	F _v		C _{ax}		F _v			C _{ax}																								
																											L	M	S																											
45 mm																											45 mm																													
S 61909 C TA	45	68	12	56.5	6.35	20	52.3		60.7	62.7	0.6	0.3	0.6	0.15	50.0	63.5	54.5		0.128	15	15200	13600	9600	30000	22500	80	49	230	79	460	112	390	S 61909 C TA																							
S 61909 E TA	45	68	12	56.5	6.35	20	52.3		60.7	62.7	0.6	0.3	0.6	0.15	50.0	63.5	54.5		0.128	25	14300	12900	9100	25500	19000	120	115	360	173	720	232	520	S 61909 E TA																							
SM 61909 C TA	45	68	12	56.5	6.35	20	52.3		60.7	62.7	0.6	0.3	0.6	0.15	50.0	63.5	54.5		0.128	17	10600	6800	4800	35000	26000	55	42	160	64	320	85	365	SM 61909 C TA																							
KH 61909 C TA	45	68	12	56.5	4.762	28	52.3	50.8	60.7	62.2	0.6	0.3	0.6	0.15	50.0	63.5	53.8		0.128	17	7300	5150	3600	38000	28500	35	40	110	61	220	81	265	KH 61909 C TA																							
KH 61909 E TA	45	68	12	56.5	4.762	28	52.3	50.8	60.7	62.2	0.6	0.3	0.6	0.15	50.0	63.5	53.8		0.128	25	6950	4900	3450	34000	25500	60	86	170	124	350	162	335	KH 61909 E TA																							
S 6009 C TA	45	75	16	60.0	8.731	18	54.7		65.0	68.6	1.0	0.6	1.0	0.3	51.0	69.0	57.6		0.238	15	27000	22600	15900	28000	21000	130	60	400	105	800	150	690	S 6009 C TA																							
S 6009 E TA	45	75	16	60.0	8.731	18	54.7		65.0	68.6	1.0	0.6	1.0	0.3	51.0	69.0	57.6		0.238	25	26000	21500	15100	24000	18000	210	140	650	220	1300	300	950	S 6009 E TA																							
SM 6009 C TA	45	75	16	60.0	8.731	18	54.7		65.0	68.6	1.0	0.6	1.0	0.3	51.0	69.0	57.6		0.238	15	18500	11400	8000	33000	24500	90	44	275	69	550	93	560	SM 6009 C TA																							
KH 6009 C TA	45	75	16	60.0	6.35	22	54.7	53	65.6	67.8	1.0	0.6	1.0	0.3	51.0	69.0	56.9		0.238	17	10800	6950	4900	36000	27000	55	44	160	65	330	88	390	KH 6009 C TA																							
KH 6009 E TA	45	75	16	60.0	6.35	22	54.7	53	65.6	67.8	1.0	0.6	1.0	0.3	51.0	69.0	56.9		0.238	25	10300	6650	4700	32000	24000	90	92	260	135	520	175	490	KH 6009 E TA																							
S 6209 C TA	45	85	19	65.0	12.7	14	57.4		72.5	77.5	1.1	0.6	1.0	0.6	53.0	77.0	61.7		0.416	15	45500	33500	23500	26000	19500	230	71	700	119	1400	171	1170	S 6209 C TA																							
S 6209 E TA	45	85	19	65.0	12.7	14	57.4		72.5	77.5	1.1	0.6	1.0	0.6	53.0	77.0	61.7		0.416	25	43500	32500	22600	22500	17000	370	169	1100	257	2200	346	1580	S 6209 E TA																							
50 mm																											50 mm																													
S 61910 C TA	50	72	12	61.0	6.35	21	56.8		65.2	67.2	0.6	0.3	0.6	0.15	55.0	67.5	58.9		0.129	15	15400	14500	10200	28000	21000	80	50	230	81	460	115	395	S 61910 C TA																							
S 61910 E TA	50	72	12	61.0	6.35	21	56.8		65.2	67.2	0.6	0.3	0.6	0.15	55.0	67.5	58.9		0.129	25	14500	13700	9700	24000	18000	120	119	370	180	740	241	530	S 61910 E TA																							
SM 61910 C TA	50	72	12	61.0	6.35	21	56.8		65.2	67.2	0.6	0.3	0.6	0.15	55.0	67.5	58.9		0.129	17	10900	7200	5100	33000	24500	55	44	170	67	330	89	375	SM 61910 C TA																							
KH 61910 C TA	50	72	12	61.0	4.762	30	56.8	55.3	65.2	66.7	0.6	0.3	0.6	0.15	55.0	67.5	58.3		0.129	17	7500	5550	3900	35000	26000	40	44	110	64	230	86	270	KH 61910 C TA																							
KH 61910 E TA	50	72	12	61.0	4.762	30	56.8	55.3	65.2	66.7	0.6	0.3	0.6	0.15	55.0	67.5	58.3		0.129	25	7150	5300	3700	32000	24000	60	90	180	132	360	171	340	KH 61910 E TA																							
S 6010 C TA	50	80	16	65.0	8.731	19	59.7		70.0	73.6	1.0	0.6	1.0	0.3	56.0	74.0	62.5		0.256	15	28000	24300	17100	26000	19500	140	64	420	110	840	160	715	S 6010 C TA																							
S 6010 E TA	50	80	16	65.0	8.731	19	59.7		70.0	73.6	1.0	0.6	1.0	0.3	56.0	74.0	62.5		0.256	25	26500	23100	16300	22000	16500	220	145	670	230	1330	310	970	S 6010 E TA																							
SM 6010 C TA	50	80	16	65.0	8.731	19	59.7		70.0	73.6	1.0	0.6	1.0	0.3	56.0	74.0	62.5		0.256	15	19000	12300	8600	31000	23000	100	47	290	72	580	99	570	SM 6010 C TA																							
KH 6010 C TA	50	80	16	65.0	6.35	25	59.7	58	70.7	73.1	1.0	0.6	1.0	0.3	56.0	74.0	61.9		0.256	17	11600	8000	5650	33000	24500	60	49	180	74	350	98	415	KH 6010 C TA																							
KH 6010 E TA	50	80	16	65.0	6.35	25	59.7	58	70.7	73.1	1.0	0.6	1.0	0.3	56.0	74.0	61.9		0.256	25	11100	7600	5350	30000	22500	90	100	280	150	560	194	530	KH 6010 E TA																							
S 6210 C TA	50	90	20	70.0	12.7	15	62.5		76.9	82.7	1.1	0.6	1.0	0.6	58.0	82.0	66.7		0.486	15	47500	37000	26000	24500	18500	240	75	720	125	1440	178	1220	S 6210 C TA																							
S 6210 E TA	50	90	20	70.0	12.7	15	62.5		76.9	82.7	1.1	0.6	1.0	0.6	58.0	82.0	66.7		0.486	25	45000	35500	24700	20500	15500	380	177	1140	271	2280	363	1640	S 6210 E TA																							

55 to 60 mm

Designation	Boundary dimensions			Balls			Dimensions						Abutment dimensions				Weight m	Contact angle α_0	Load rating			Speed value		Preload/axial rigidity						Spring preload F _f	Designation		
	d	D	B	d _m	D _W	Z	d ₁	d ₂	D ₁	D ₂	r _{1,2}	r _{3,4}	r _{a max}	r _{b max}	d _{a, b min}	D _{a, b max}			d _T	C	C ₀	C _{0 HY}	n _{oil}	n _{grease}	F _V	C _{ax}	F _V	C _{ax}	F _V			C _{ax}	L
55 mm																55 mm																	
S 61911 C TA	55	80	13	67.5	7.144	21	63.1		71.9	74.5	1.0	0.3	0.6	0.3	60.0	75.0	65.4		0.181	15	18400	17100	12100	25000	18500	90	52	280	87	560	122	470	S 61911 C TA
S 61911 E TA	55	80	13	67.5	7.144	21	63.1		71.9	74.5	1.0	0.3	0.6	0.3	60.0	75.0	65.4		0.181	25	17400	16200	11400	21500	16000	150	130	440	193	880	257	635	S 61911 E TA
SM 61911 C TA	55	80	13	67.5	7.144	21	63.1		71.9	74.5	1.0	0.3	0.6	0.3	60.0	75.0	65.4		0.181	17	13600	9400	6600	29500	22000	70	49	210	75	420	100	465	SM 61911 C TA
KH 61911 C TA	55	80	13	67.5	5.556	30	63.1	61.8	72.9	74.5	1.0	0.3	0.6	0.3	60.0	75.0	65.0		0.181	17	10000	7500	5250	31000	23000	50	50	150	75	300	99	360	KH 61911 C TA
KH 61911 E TA	55	80	13	67.5	5.556	30	63.1	61.8	72.9	74.5	1.0	0.3	0.6	0.3	60.0	75.0	65.0		0.181	25	9600	7150	5050	28500	21500	80	104	240	154	480	199	460	KH 61911 E TA
S 6011 C TA	55	90	18	72.5	9.525	20	66.8		78.2	81.9	1.1	1.0	1.1	0.6	62.0	83.0	69.8		0.374	15	32500	29500	20500	23500	17500	160	69	490	115	980	163	830	S 6011 C TA
S 6011 E TA	55	90	18	72.5	9.525	20	66.8		78.2	81.9	1.1	1.0	1.1	0.6	62.0	83.0	69.8		0.374	25	30500	28000	19400	20000	15000	260	167	770	253	1540	337	1110	S 6011 E TA
SM 6011 C TA	55	90	18	72.5	9.525	20	66.8		78.2	81.9	1.1	1.0	1.1	0.6	62.0	83.0	69.8		0.374	15	23100	15500	10900	27500	20500	115	52	350	81	700	110	695	SM 6011 C TA
KH 6011 C TA	55	90	18	72.5	7.938	23	66.8	65.6	79.2	82.4	1.1	1.0	1.1	0.6	62.0	83.0	69.3		0.374	17	16700	11400	8000	29500	22000	80	55	250	84	500	111	600	KH 6011 C TA
KH 6011 E TA	55	90	18	72.5	7.938	23	66.8	65.6	79.2	82.4	1.1	1.0	1.1	0.6	62.0	83.0	69.3		0.374	25	15900	10800	7600	26500	20000	130	115	400	172	800	223	760	KH 6011 E TA
S 6211 C TA	55	100	21	77.5	14.288	15	69.0		85.8	91.6	1.5	1.0	1.5	1.0	64.0	91.0	73.8		0.621	15	58000	46000	32500	22000	16500	300	83	900	139	1800	199	1480	S 6211 C TA
S 6211 E TA	55	100	21	77.5	14.288	15	69.0		85.8	91.6	1.5	1.0	1.5	1.0	64.0	91.0	73.8		0.621	25	55500	44000	31000	18500	14000	470	198	1400	300	2800	404	2020	S 6211 E TA
60 mm																60 mm																	
S 61912 C TA	60	85	13	72.5	7.144	23	68.1		76.9	79.5	1.0	0.3	0.6	0.3	65.0	80.0	70.4		0.195	15	19200	19000	13300	23500	17500	100	58	300	94	600	132	490	S 61912 C TA
S 61912 E TA	60	85	13	72.5	7.144	23	68.1		76.9	79.5	1.0	0.3	0.6	0.3	65.0	80.0	70.4		0.195	25	18100	17900	12600	20000	15000	150	137	460	208	920	276	660	S 61912 E TA
SM 61912 C TA	60	85	13	72.5	7.144	23	68.1		76.9	79.5	1.0	0.3	0.6	0.3	65.0	80.0	70.4		0.195	19	14100	10300	7200	27500	20500	70	61	220	93	430	122	540	SM 61912 C TA
KH 61912 C TA	60	85	13	72.5	5.556	32	68.1	66.8	77.9	79.5	1.0	0.3	0.6	0.3	65.0	80.0	70.0		0.195	17	10300	8100	5650	29500	22000	50	52	160	80	310	104	370	KH 61912 C TA
KH 61912 E TA	60	85	13	72.5	5.556	32	68.1	66.8	77.9	79.5	1.0	0.3	0.6	0.3	65.0	80.0	70.0		0.195	25	9800	7700	5400	26500	20000	80	109	240	161	490	209	470	KH 61912 E TA
S 6012 C TA	60	95	18	77.5	9.525	22	71.9		83.2	87.0	1.1	1.0	1.1	0.6	67.0	88.0	74.9		0.406	15	34000	32500	22800	22000	16500	170	75	515	124	1030	175	870	S 6012 C TA
S 6012 E TA	60	95	18	77.5	9.525	22	71.9		83.2	87.0	1.1	1.0	1.1	0.6	67.0	88.0	74.9		0.406	25	32000	31000	21600	18500	14000	270	180	810	274	1620	364	1160	S 6012 E TA
SM 6012 C TA	60	95	18	77.5	9.525	22	71.9		83.2	87.0	1.1	1.0	1.1	0.6	67.0	88.0	74.9		0.406	15	24500	17400	12200	26000	19500	125	56	375	83	750	120	740	SM 6012 C TA
KH 6012 C TA	60	95	18	77.5	7.938	24	71.9	70.7	84.2	87.4	1.1	1.0	1.1	0.6	67.0	88.0	74.4		0.406	17	17000	11900	8400	27500	20500	90	59	260	87	510	115	610	KH 6012 C TA
KH 6012 E TA	60	95	18	77.5	7.938	24	71.9	70.7	84.2	87.4	1.1	1.0	1.1	0.6	67.0	88.0	74.4		0.406	25	16200	11400	8000	25000	18500	140	122	400	177	800	229	770	KH 6012 E TA
S 6212 C TA	60	110	22	85.0	15.875	15	76.0		95.5	101.4	1.5	1.0	1.5	1.0	70.0	101.0	81.5		0.795	15	70000	56500	40000	20000	15000	350	90	1000	146	2100	213	1790	S 6212 C TA
S 6212 E TA	60	110	22	85.0	15.875	15	76.0		95.5	101.4	1.5	1.0	1.5	1.0	70.0	101.0	81.5		0.795	25	66500	54000	38000	17000	12500	560	216	1700	333	3400	443	2420	S 6212 E TA

65 to 75 mm

Designation	Boundary dimensions			Balls			Dimensions						Abutment dimensions				Weight m	Contact angle α_0	Load rating			Speed value		Preload/axial rigidity						Spring preload F _f	Designation																								
	d	D	B	d _m	D _W	Z	d ₁	d ₂	D ₁	D ₂	r _{1,2}	r _{3,4}	r _{a max}	r _{b max}	d _{a, b min}	D _{a, b max}			d _T	C	C ₀	C _{0 HY}	n _{oil}	n _{grease}	F _v	C _{ax}	F _v	C _{ax}	F _v			C _{ax}																							
																			L	M	S																																		
65 mm																												65 mm																											
S 61913 C TA	65	90	13	77.5	7.144	24	73.1		81.9	84.5	1.0	0.3	0.6	0.3	70.0	85.0	75.4		0.207	15	19500	20000	14000	22000	16500	100	59	300	96	600	135	500	S 61913 C TA																						
S 61913 E TA	65	90	13	77.5	7.144	24	73.1		81.9	84.5	1.0	0.3	0.6	0.3	70.0	85.0	75.4		0.207	25	18300	18900	13300	18500	14000	160	144	470	215	940	286	665	S 61913 E TA																						
SM 61913 C TA	65	90	13	77.5	7.144	24	73.1		81.9	84.5	1.0	0.3	0.6	0.3	70.0	85.0	75.4		0.207	19	14400	10800	7600	26000	19500	75	64	220	96	440	126	550	SM 61913 C TA																						
KH 61913 C TA	65	90	13	77.5	5.556	34	73.1	71.8	82.9	84.5	1.0	0.3	0.6	0.3	70.0	85.0	75.0		0.207	17	10600	8600	6050	27500	20500	55	56	160	83	320	110	380	KH 61913 C TA																						
KH 61913 E TA	65	90	13	77.5	5.556	34	73.1	71.8	82.9	84.5	1.0	0.3	0.6	0.3	70.0	85.0	75.0		0.207	25	10100	8200	5800	25000	18500	80	113	250	169	500	219	480	KH 61913 E TA																						
S 6013 C TA	65	100	18	82.5	9.525	23	76.9		88.2	92.0	1.1	1.0	1.1	0.6	72.0	93.0	79.9		0.431	15	34500	34500	24100	20500	15500	175	78	525	128	1050	181	880	S 6013 C TA																						
S 6013 E TA	65	100	18	82.5	9.525	23	76.9		88.2	92.0	1.1	1.0	1.1	0.6	72.0	93.0	79.9		0.431	25	32500	32500	22900	17500	13000	275	187	825	284	1650	376	1180	S 6013 E TA																						
SM 6013 C TA	65	100	18	82.5	9.525	23	76.9		88.2	92.0	1.1	1.0	1.1	0.6	72.0	93.0	79.9		0.431	15	25000	18400	13000	24000	18000	130	58	380	91	760	123	760	SM 6013 C TA																						
KH 6013 C TA	65	100	18	82.5	7.938	25	76.9	75.7	89.2	92.4	1.1	1.0	1.1	0.6	72.0	93.0	79.3		0.431	17	17300	12500	8800	26000	19500	90	60	260	90	520	119	620	KH 6013 C TA																						
KH 6013 E TA	65	100	18	82.5	7.938	25	76.9	75.7	89.2	92.4	1.1	1.0	1.1	0.6	72.0	93.0	79.3		0.431	25	16500	11900	8400	23500	17500	140	125	410	182	800	235	790	KH 6013 E TA																						
S 6213 C TA	65	120	23	92.5	15.875	16	82.8		102.3	108.5	1.5	1.1	1.5	1.1	75.0	110.0	88.3		1.008	15	72500	61500	43500	18500	14000	370	96	1110	158	2220	225	1850	S 6213 C TA																						
S 6213 E TA	65	120	23	92.5	15.875	16	82.8		102.3	108.5	1.5	1.1	1.5	1.1	75.0	110.0	88.3		1.008	25	69000	59000	41500	15500	11500	590	228	1760	347	3520	462	2550	S 6213 E TA																						
70 mm																												70 mm																											
S 61914 C TA	70	100	16	85	7.938	24	80.1		89.9	92.7	1.0	0.3	0.6	0.3	76.0	94.5	82.6		0.346	15	24400	26000	18200	20000	15000	130	69	370	111	740	156	625	S 61914 C TA																						
S 61914 E TA	70	100	16	85	7.938	24	80.1		89.9	92.7	1.0	0.3	0.6	0.3	76.0	94.5	82.6		0.346	25	23000	24500	17300	17000	12500	200	165	590	247	1180	329	840	S 61914 E TA																						
SM 61914 C TA	70	100	16	85	7.938	24	80.1		89.9	92.7	1.0	0.3	0.6	0.3	76.0	94.5	82.6		0.346	19	17300	13000	9200	23500	17500	90	71	260	105	530	139	660	SM 61914 C TA																						
KH 61914 C TA	70	100	16	85	6.35	32	80.1	78.5	91.3	93.4	1.0	0.3	0.6	0.3	76.0	94.5	82.3		0.346	17	13000	10600	7400	25000	18500	65	59	200	89	390	118	465	KH 61914 C TA																						
KH 61914 E TA	70	100	16	85	6.35	32	80.1	78.5	91.3	93.4	1.0	0.3	0.6	0.3	76.0	94.5	82.3		0.346	25	12400	10100	7050	22500	17000	100	122	310	182	620	235	590	KH 61914 E TA																						
S 6014 C TA	70	110	20	90	11.906	21	82.6		97.4	101.7	1.1	1.0	1.1	0.6	77.0	102.0	86.6		0.593	15	48500	46000	32500	19000	14000	240	85	700	140	1400	200	1240	S 6014 C TA																						
S 6014 E TA	70	110	20	90	11.906	21	82.6		97.4	101.7	1.1	1.0	1.1	0.6	77.0	102.0	86.6		0.593	25	46000	43500	30500	16000	12000	400	200	1200	310	2400	420	1670	S 6014 E TA																						
SM 6014 C TA	70	110	20	90	11.906	21	82.6		97.4	101.7	1.1	1.0	1.1	0.6	77.0	102.0	86.6		0.593	15	35500	25500	17800	22000	16500	180	66	500	99	1000	134	1070	SM 6014 C TA																						
KH 6014 C TA	70	110	20	90	9.525	24	82.6	81.1	96.7	100.8	1.1	1.0	1.1	0.6	77.0	102.0	85.7		0.593	17	23700	17200	12100	24000	18000	120	68	360	104	720	137	850	KH 6014 C TA																						
KH 6014 E TA	70	110	20	90	9.525	24	82.6	81.1	96.7	100.8	1.1	1.0	1.1	0.6	77.0	102.0	85.7		0.593	25	22700	16400	11500	21500	16000	190	143	570	211	1150	274	1080	KH 6014 E TA																						
75 mm																												75 mm																											
S 61915 C TA	75	105	16	90	8.731	25	84.7		95.3	98.8	0.6	0.3	0.6	0.3	81.0	99.5	87.5		0.35	15	29500	31000	21600	19000	14000	150	75	440	120	890	169	760	S 61915 C TA																						
S 61915 E TA	75	105	16	90	8.731	25	84.7		95.3	98.8	0.6	0.3	0.6	0.3	81.0	99.5	87.5		0.35	25	27500	29500	20500	16000	12000	230	178	700	270	1400	360	1000	S 61915 E TA																						
SM 61915 C TA	75	105	16	90	8.731	25	84.7		95.3	98.8	0.6	0.3	0.6	0.3	81.0	99.5	87.5		0.35	19	20800	16000	11300	22000	16500	110	78	320	116	640	153	800	SM 61915 C TA																						
S 6015 C TA	75	115	20	95	11.906	22	87.8		102.2	107	1.1	0.6	1.1	0.6	82.0	107.0	91.7		0.64	15	49500	48500	34000	18000	13500	250	91	760	148	1510	208	1270	S 6015 C TA																						
S 6015 E TA	75	115	20	95	11.906	22	87.8		102.2	107	1.1	0.6	1.1	0.6	82.0	107.0	91.7		0.64	25	47000	46000	32500	15500	11500	400	219	1190	330	2380	440	1710	S 6015 E TA																						
SM 6015 C TA	75	115	20	95	11.906	22	87.8		102.2	107	1.1	0.6	1.1	0.6	82.0	107.0	91.7		0.64	17	36000	26500	18700	21000	15500	180	82	550	126	1100	167	1230	SM 6015 C TA																						

80 to 95 mm

Designation	Boundary dimensions			Balls			Dimensions						Abutment dimensions				Weight m	Contact angle α_0	Load rating			Speed value		Preload/axial rigidity						Spring preload F _f	Designation																								
	d	D	B	d _m	D _W	Z	d ₁	d ₂	D ₁	D ₂	r _{1,2}	r _{3,4}	r _{a max}	r _{b max}	d _{a, b min}	D _{a, b max}			d _T	C	C ₀	C _{0 HY}	n _{oil}	n _{grease}	F _V	C _{ax}	F _V	C _{ax}	F _V			C _{ax}	F _V	C _{ax}	L	M	S																		
80 mm																												80 mm																											
S 61916 C TA	80	110	16	95	9.525	25	89.4		100.8	104.6	0.6	0.3	0.6	0.3	86	104	92.4		0.37	15	35500	38500	27000	18000	13500	180	84	540	136	1080	192	910	S 61916 C TA																						
S 61916 E TA	80	110	16	95	9.525	25	89.4		100.8	104.6	0.6	0.3	0.6	0.3	86	104	92.4		0.37	25	33500	36500	25500	15500	11500	280	199	840	305	1680	400	1220	S 61916 E TA																						
SM 61916 C TA	80	110	16	95	9.525	25	89.4		100.8	104.6	0.6	0.3	0.6	0.3	86	104	92.4		0.37	19	25500	20100	14200	21000	15500	130	88	390	133	780	175	970	SM 61916 C TA																						
S 6016 C TA	80	125	22	102.5	13.494	20	94.3		110.7	116.1	1.1	0.6	1.1	0.6	88	117	98.7		0.84	15	60000	58000	41000	16500	12500	310	98	920	159	1830	224	1540	S 6016 C TA																						
S 6016 E TA	80	125	22	102.5	13.494	20	94.3		110.7	116.1	1.1	0.6	1.1	0.6	88	117	98.7		0.84	25	57500	56500	40000	14000	10500	490	235	1470	360	2930	475	2090	S 6016 E TA																						
SM 6016 C TA	80	125	22	102.5	13.494	20	94.3		110.7	116.1	1.1	0.6	1.1	0.6	88	117	98.7		0.84	17	43000	31000	21600	19500	14500	220	87	650	131	1300	174	1470	SM 6016 C TA																						
85 mm																												85 mm																											
S 61917 C TA	85	120	18	102.5	10.319	25	96.2		108.8	112.9	0.6	0.6	0.6	0.6	92	114	99.5		0.54	15	40000	43000	30500	16500	12500	200	87	610	142	1220	198	1020	S 61917 C TA																						
S 61917 E TA	85	120	18	102.5	10.319	25	96.2		108.8	112.9	0.6	0.6	0.6	0.6	92	114	99.5		0.54	25	37500	40500	28500	14000	10500	320	210	960	320	1910	420	1360	S 61917 E TA																						
SM 61917 C TA	85	120	18	102.5	10.319	25	96.2		108.8	112.9	0.6	0.6	0.6	0.6	92	114	99.5		0.54	19	29500	23200	16300	19500	14500	150	94	440	140	890	185	1130	SM 61917 C TA																						
S 6017 C TA	85	130	22	107.5	13.494	21	99.3		115.7	121.1	1.1	0.6	1.1	0.6	93	122	103.7		0.89	15	61500	61500	43500	16000	12000	310	101	940	165	1880	233	1570	S 6017 C TA																						
S 6017 E TA	85	130	22	107.5	13.494	21	99.3		115.7	121.1	1.1	0.6	1.1	0.6	93	122	103.7		0.89	25	59000	60000	42000	13500	10000	500	245	1500	370	3000	495	2140	S 6017 E TA																						
SM 6017 C TA	85	130	22	107.5	13.494	21	99.3		115.7	121.1	1.1	0.6	1.1	0.6	93	122	103.7		0.89	17	44000	32500	22900	18500	14000	220	89	670	137	1340	182	1500	SM 6017 C TA																						
90 mm																												90 mm																											
S 61918 C TA	90	125	18	107.5	10.319	26	101.2		113.8	117.9	0.6	0.6	0.6	0.6	97	119	104.5		0.56	15	40500	45000	31500	16000	12000	210	91	620	146	1240	204	1040	S 61918 C TA																						
S 61918 E TA	90	125	18	107.5	10.319	26	101.2		113.8	117.9	0.6	0.6	0.6	0.6	97	119	104.5		0.56	25	38500	42500	30000	13500	10000	320	216	970	330	1940	435	1400	S 61918 E TA																						
SM 61918 C TA	90	125	18	107.5	10.319	26	101.2		113.8	117.9	0.6	0.6	0.6	0.6	97	119	104.5		0.56	19	30000	24200	17000	18500	14000	150	97	450	145	910	191	1140	SM 61918 C TA																						
S 6018 C TA	90	140	24	115	15.081	20	105.8		124.2	130.1	1.5	0.6	1.5	0.6	100	131	110.7		1.15	15	74500	74000	52000	15000	11000	380	110	1130	179	2270	255	1900	S 6018 C TA																						
S 6018 E TA	90	140	24	115	15.081	20	105.8		124.2	130.1	1.5	0.6	1.5	0.6	100	131	110.7		1.15	25	70500	70000	49500	12500	9400	600	265	1790	400	3570	525	2600	S 6018 E TA																						
SM 6018 C TA	90	140	24	115	15.081	20	105.8		124.2	130.1	1.5	0.6	1.5	0.6	100	131	110.7		1.15	17	52000	38500	27000	17500	13000	270	96	800	146	1590	194	1770	SM 6018 C TA																						
95 mm																												95 mm																											
S 61919 C TA	95	130	18	112.5	10.319	27	106.2		118.8	122.9	0.6	0.6	0.6	0.6	102	124	109.5		0.59	15	41000	47000	33000	15000	11000	210	93	630	150	1250	209	1050	S 61919 C TA																						
S 61919 E TA	95	130	18	112.5	10.319	27	106.2		118.8	122.9	0.6	0.6	0.6	0.6	102	124	109.5		0.59	25	39000	44500	31500	13000	9800	330	223	980	335	1970	445	1420	S 61919 E TA																						
SM 61919 C TA	95	130	18	112.5	10.319	27	106.2		118.8	122.9	0.6	0.6	0.6	0.6	102	124	109.5		0.59	19	30500	25500	17800	18000	13500	150	99	460	150	920	196	1160	SM 61919 C TA																						
S 6019 C TA	95	145	24	120	15.081	21	110.8		129.2	135.1	1.5	0.6	1.5	0.6	105	136	115.7		1.20	15	77000	79000	55000	14000	10500	390	114	1160	186	2330	265	1970	S 6019 C TA																						
S 6019 E TA	95	145	24	120	15.081	21	110.8		129.2	135.1	1.5	0.6	1.5	0.6	105	136	115.7		1.20	25	72000	74500	52500	12000	9000	610	275	1830	415	3660	550	2650	S 6019 E TA																						
SM 6019 C TA	95	145	24	120	15.081	21	110.8		129.2	135.1	1.5	0.6	1.5	0.6	105	136	115.7		1.20	17	53500	41000	28500	16500	12500	270	99	820	152	1640	202	1820	SM 6019 C TA																						

100 to 120 mm

Designation	Boundary dimensions			Balls			Dimensions						Abutment dimensions				Weight m	Contact angle α_0	Load rating			Speed value		Preload/axial rigidity						Spring preload F _f	Designation																								
	d	D	B	d _m	D _W	Z	d ₁	d ₂	D ₁	D ₂	r _{1,2}	r _{3,4}	r _{a max}	r _{b max}	d _{a, b min}	D _{a, b max}			d _T	C	C ₀	C _{0 HY}	n _{oil}	n _{grease}	F _V	C _{ax}	F _V	C _{ax}	F _V			C _{ax}	F _V	C _{ax}	L	M	S																		
100 mm																												100 mm																											
S 61920 C TA	100	140	20	120	11.906	25	112.8		127.2	132.0	0.6	0.6	0.6	0.6	107	133	116.5		0.80	15	51500	57000	40500	14000	10500	260	100	790	162	1570	226	1320	S 61920 C TA																						
S 61920 E TA	100	140	20	120	11.906	25	112.8		127.2	132.0	0.6	0.6	0.6	0.6	107	133	116.5		0.80	25	48500	54000	38000	12000	9000	410	240	1230	365	2470	480	1760	S 61920 E TA																						
SM 61920 C TA	100	140	20	120	11.906	25	112.8		127.2	132.0	0.6	0.6	0.6	0.6	107	133	116.5		0.80	19	37500	31000	21700	16500	12500	190	107	570	160	1150	211	1430	SM 61920 C TA																						
S 6020 C TA	100	150	24	125	15.081	22	115.8		134.2	140.1	1.5	0.6	1.5	0.6	110	141	120.7		1.25	15	78000	83000	58000	13500	10000	400	118	1190	193	2380	275	1990	S 6020 C TA																						
S 6020 E TA	100	150	24	125	15.081	22	115.8		134.2	140.1	1.5	0.6	1.5	0.6	110	141	120.7		1.25	25	74000	79000	55000	11500	8600	630	285	1880	430	3750	570	2700	S 6020 E TA																						
SM 6020 C TA	100	150	24	125	15.081	22	115.8		134.2	140.1	1.5	0.6	1.5	0.6	110	141	120.7		1.25	17	55000	43000	30500	16000	12000	280	104	840	158	1680	210	1880	SM 6020 C TA																						
105 mm																												105 mm																											
S 61921 C TA	105	145	20	125	11.906	26	117.8		132.2	137.0	0.6	0.6	0.6	0.6	112	138	121.5		0.83	15	52500	60000	42000	13500	10000	270	103	800	166	1600	232	1340	S 61921 C TA																						
S 61921 E TA	105	145	20	125	11.906	26	117.8		132.2	137.0	0.6	0.6	0.6	0.6	112	138	121.5		0.83	25	49500	56500	40000	11500	8600	420	248	1250	375	2510	495	1800	S 61921 E TA																						
SM 61921 C TA	105	145	20	125	11.906	26	117.8		132.2	137.0	0.6	0.6	0.6	0.6	112	138	121.5		0.83	19	38500	32500	22700	16000	12000	200	112	590	166	1170	218	1470	SM 61921 C TA																						
S 6021 C TA	105	160	26	132.5	15.875	22	122.8		142.2	148.4	2.0	1.0	2.0	1.0	116	150	127.9		1.59	15	86000	92000	64500	13000	9800	440	125	1310	203	2610	285	2200	S 6021 C TA																						
S 6021 E TA	105	160	26	132.5	15.875	22	122.8		142.2	148.4	2.0	1.0	2.0	1.0	116	150	127.9		1.59	25	81000	87000	61500	11000	8200	690	300	2060	450	4120	595	2950	S 6021 E TA																						
SM 6021 C TA	105	160	26	132.5	15.875	22	122.8		142.2	148.4	2.0	1.0	2.0	1.0	116	150	127.9		1.59	17	60500	48000	34000	15000	11000	310	109	930	166	1850	221	2060	SM 6021 C TA																						
110 mm																												110 mm																											
S 61922 C TA	110	150	20	130	11.906	27	122.8		137.2	142.0	0.6	0.6	0.6	0.6	117	143	126.5		0.86	15	53500	62500	44000	13000	9800	270	106	810	170	1620	238	1370	S 61922 C TA																						
S 61922 E TA	110	150	20	130	11.906	27	122.8		137.2	142.0	0.6	0.6	0.6	0.6	117	143	126.5		0.86	25	50000	59000	41500	11000	8200	420	255	1270	385	2550	510	1820	S 61922 E TA																						
SM 61922 C TA	110	150	20	130	11.906	27	122.8		137.2	142.0	0.6	0.6	0.6	0.6	117	143	126.5		0.86	19	39000	34000	23700	15500	11500	200	114	600	171	1190	224	1490	SM 61922 C TA																						
S 6022 C TA	110	170	28	140	17.462	21	129.4		150.6	157.5	2.0	1.0	2.0	1.0	121	159	135.0		1.98	15	99000	105000	73500	12000	9000	500	130	1510	212	3020	300	2550	S 6022 C TA																						
S 6022 E TA	110	170	28	140	17.462	21	129.4		150.6	157.5	2.0	1.0	2.0	1.0	121	159	135.0		1.98	25	94000	100000	70000	10500	7900	790	310	2380	470	4760	625	3450	S 6022 E TA																						
SM 6022 C TA	110	170	28	140	17.462	21	129.4		150.6	157.5	2.0	1.0	2.0	1.0	121	159	135.0		1.98	17	70000	55000	39000	14500	11000	360	115	1070	174	2140	232	2380	SM 6022 C TA																						
120 mm																												120 mm																											
S 61924 C TA	120	165	22	142.5	13.494	27	134.3		150.7	156.0	0.6	0.6	0.6	0.6	128	157	138.5		1.18	15	67500	80000	56000	12000	9000	340	120	1030	195	2060	275	1730	S 61924 C TA																						
S 61924 E TA	120	165	22	142.5	13.494	27	134.3		150.7	156.0	0.6	0.6	0.6	0.6	128	157	138.5		1.18	25	64000	76000	53000	10000	7500	540	290	1620	440	3250	580	2320	S 61924 E TA																						
SM 61924 C TA	120	165	22	142.5	13.494	27	134.3		150.7	156.0	0.6	0.6	0.6	0.6	128	157	138.5		1.18	19	49500	43500	30500	14000	10500	250	129	750	194	1500	255	1890	SM 61924 C TA																						
S 6024 C TA	120	180	28	150	17.462	23	139.4		160.6	167.5	2.0	1.0	2.0	1.0	131	169	145.0		2.13	15	104000	116000	82000	11500	8600	530	140	1580	227	3170	320	2700	S 6024 C TA																						
S 6024 E TA	120	180	28	150	17.462	23	139.4		160.6	167.5	2.0	1.0	2.0	1.0	131	169	145.0		2.13	25	98000	110000	78000	9700	7300	830	335	2490	510	4990	670	3600	S 6024 E TA																						
SM 6024 C TA	120	180	28	150	17.462	23	139.4		160.6	167.5	2.0	1.0	2.0	1.0	131	169	145.0		2.13	17	74000	61000	43000	13500	10000	380	124	1130	188	2250	250	2550	SM 6024 C TA																						

Comparable bearing types

Basic types									
GMN	ISO	Barden	Fafnir	FAG	NSK	NTN	SKF	SNFA	SNR
S 61800 : S 61808	18	-	-	B 71800 : B 71808	-	7800 : 7808	-	SEA 10 : SEA 40	-
HY S 61808	18	-	-	HCB 71808	-	5S- 7808	-	SEA 40 /NS	-
S 61900 : S 61924	19	1900H : 1924H	9300 WI : 9324 WI	B 71900 : B 71924	7900 : 7924	7900U : 7924U	71900 : 71924	SEB 10 : SEB 120	71900 : 71924
HY S 61924	19	C1924H	C 9324 WI	HCB 71924	7924 SN24	5S- 7924U	71924 HC	SEB 120 /NS	CH 71924
S 6000 : S 6024	10	100 H : 124 H	9100 WI : 9124 WI	B 7000 : B 7024	7000 : 7024	7000U : 7024U	7000 : 7024	EX 10 : EX 120	7000 : 7024
HY S 6024	10	C 124 H	C 9124 WI	HCB 7024	7024 SN24	5S- 7024U	7024 HC	EX 120 /NS	CH 7024
S 6200 : S 6213	02	200 H : 213 H	200WI : 213WI	B 7200 : B 7213	7200 : 7213	7200 : 7213	7200 : 7213	E2 10 : E2 65	7200 : 7213
HY S 6213	02	C 213 H	C 213WI	HCB 7213	7213 SN24	5S- 7213	7213 HC	E2 65 /NS	CH 7213
SM 61902 : SM 61918	19*	-	-	RS 71902 : RS 71918	-	-	-	VEB 15 : VEB 90	-
HY SM 61918	19*	-	-	HC RS 71918	-	-	-	VEB 90 /NS	-
SM 6000 : SM 6014	10*	-	-	RS 7000 : RS 7014	-	-	-	VEX 10 : VEX 70	-
HY SM 6014	10*	-	-	HC RS 7014	-	-	-	VEX 70 /NS	-
KH 61900 2RZ : KH 61914 2RZ	19*	-	-	HSS 71900 : HSS 71914	10 BNR19 V1V : 70 BNR19 V1V	2LA-BNS900CLLB : 2LA-BNS914CLLB	-	HB 10 /S : HB 70 /S	MLE 71900 : MLE 71914
HY KH 61914 2RZ	19*	-	-	HCS 71914	70 BNR19 H V1V	5S- 2LA-BNS914CLLB	-	HB 70 /NS/S	MLE CH 71914
KH 6000 2RZ : KH 6014 2RZ	10	ZSB100 RR : ZSB114 RR	-	HSS 7000 : HSS 7014	10 BNR10 V1V : 70 BNR10 V1V	2LA-BNS000C LLB : 2LA-BNS014C LLB	-	HX 10 /S : HX 70 /S	MLE 7000 : MLE 7014
HY KH 6014 2RZ	10	C ZSB114 RR	-	HCS 7014	70 BNR10 H V1V	5S- 2LA-BNS014C LLB	-	HX 70 /NS/S	MLE CH 7014

* Optimized inner geometry for increased speed. Outer diameters correspond to the given ISO group.
Designations include only the basic types (not design details like contact angle, precision, matching, preload, etc.)

GMN High precision deep groove ball bearings

- Standard series
- Special series
- Materials
- Hybrid ball bearings
- Bearing designation
- Bearing data

GMN Deep groove ball bearings Series

Materials Rings and balls

Hybrid ball bearings

Series 60../62..

General purpose
Absorbs axial and radial forces in both directions
Reference speed coefficient: $0.6 \cdot 10^6$ mm/min (steel cage)

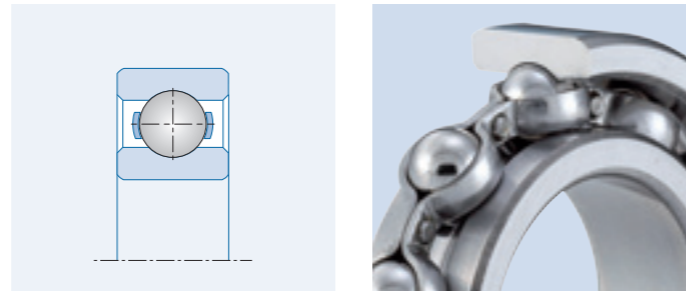

Series Z

Version with one shield (lubricated)

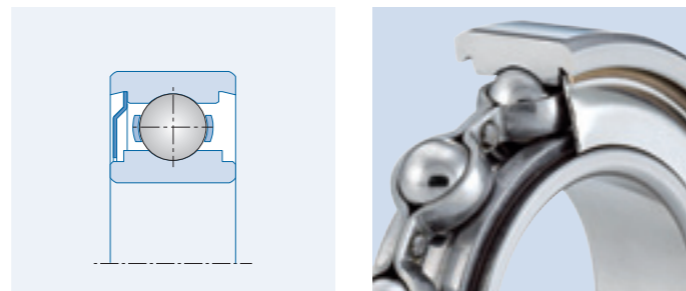

Series 2Z

Version with two shields (lubricated)

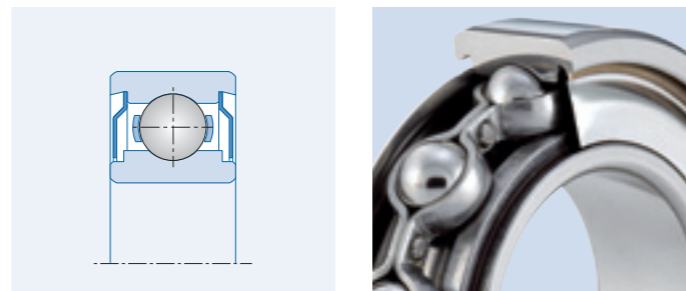

Series X2Z

Extra-wide bearing with 2 shields (lubricated)
Reference speed coefficient: $1.0 \cdot 10^6$ mm/min

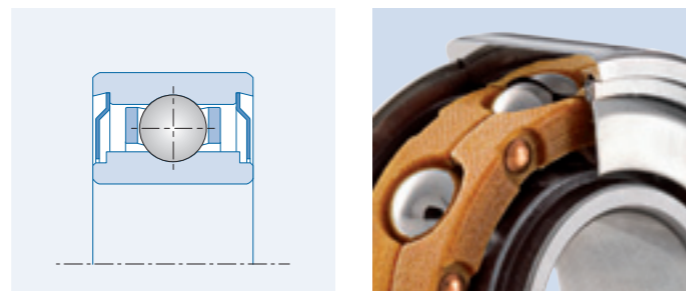

GMN deep groove ball bearing components are manufactured exclusively from high-quality materials and processing techniques. The highest standards of quality assure the best possible performance efficiency and optimal service life for GMN products.

Rings and balls (standard material)

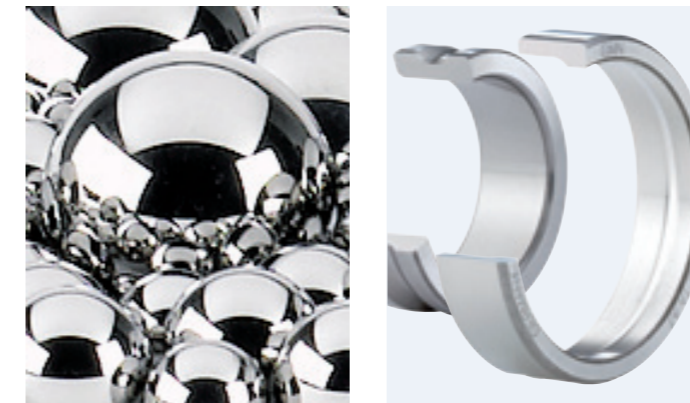

Material
Bearing steel (chrome steel) 100 Cr 6
Material no. 1.3505, SAE 52100, SUJ2
Special steels on request

Permissible operating temperature
Heat treated for continuous operating temperatures up to 150°C

Hardness
60 to 64 HRC, fully hardened; corresponds to 700–800 HV30

Characteristics
High purity and homogeneity, vacuum-degassed

Hybrid ball bearings are characterized by a combination of materials; bearing steel (inner and outer rings) and ceramic (balls). The material-based characteristics of ceramic balls (in comparison to bearings with steel balls) offer clear performance improvements, especially under intense operational conditions in machine utilization.

Balls (hybrid ball bearings)



Material
Ceramic (silicon nitride Si₃N₄)

Material characteristics

- Low chemical affinity to 100 Cr 6
- Low friction coefficient
- Low heat conductivity
- Corrosion resistance
- Non magnetic
- Electrically insulating

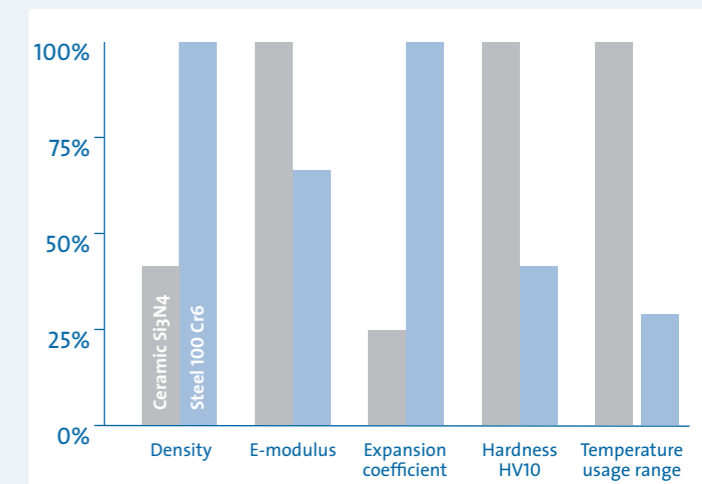

Materials Cages

Clearance

GMN high precision deep groove ball bearings are basically equipped with a steel cage (J cage). Depending on specific requirements (e.g. high speeds), cages made of other materials are available.

The distance by which one bearing ring can be displaced relative to the other without measurable loading is defined as clearance.

- Axial clearance: displacement in the axial direction
- Radial clearance: displacement in the radial direction

J cage



Material
Sheet steel

Permissible operating temperature 220°C

Fabrication
two piece, tab-clamped or riveted

T9H cage



Material
Polyamide (fiberglass reinforced)

Permissible operating temperature 140°C

Fabrication
single piece, crown cage

TBH cage



Material
Laminated phenolic resin

Permissible operating temperature 120°C

Fabrication
single piece, crown cage

TA, TB cages



Material
Laminated phenolic resin

Permissible operating temperature 120°C

Fabrication
two piece, riveted

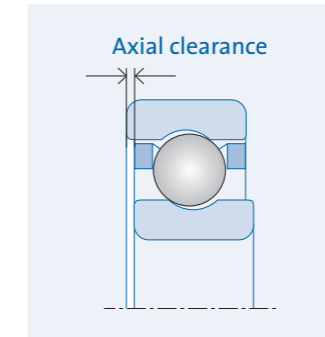
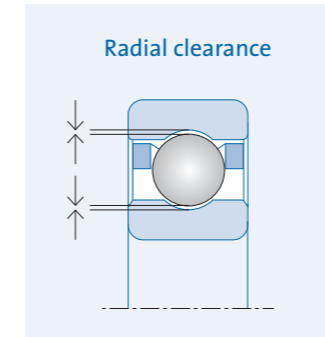

GMN Deep groove ball bearings: Radial clearance (per DIN 620/Part 4)									
Bore diameter d [mm]		Radial clearance [µm]							
		C2		CN		C3		C4	
over	including	min	max	min	max	min	max	min	max
1.5	6	0	7	2	13	8	23	-	-
6	10	0	7	2	13	8	23	14	29
10	18	0	9	3	18	11	25	18	33
18	24	0	10	5	20	13	28	20	36
24	30	1	11	5	20	13	28	23	41
30	40	1	11	6	20	15	33	28	46

Deep groove ball bearings without a clearance specification are fabricated to CN specification (standard clearance).

Bearing designation

Example

Material	- HY	Bearings made of bearing steel have no designation Balls and rings made of different materials (HYBRID bearings)
Bearing size	6001	Designation of dimension series and bore diameter
Series, Seal	X Z ZZ	Extra-wide bearing Shield on one side, fastened with snap ring Shields on both sides, fastened with snap rings Shields are on the outer faces of bearing pairs
Cage	J T9H TBH TA TB MA	Sheet steel cage Crown cage of fiberglass reinforced polyamide, ball-guided Crown cage of laminated phenolic resin, inner land guided Solid cage of laminated phenolic resin, outer land guided Solid cage of laminated phenolic resin, inner land guided Solid cage of brass, outer land guided
Precision	P4 P2 A7 A9 HG UP	Tolerance class P4 Tolerance class P2 ABEC 7 per ABMA standards, corresponds to P4 ABEC 9 per ABMA standards, corresponds to P2 GMN high precision per GMN specification GMN ultra precision per GMN specification
Clearance	C2 - C3 C4	Radial clearance smaller than standard Standard clearance (no designation) Radial clearance greater than standard Radial clearance greater than C3 Reduced radial clearance values are stated in plain text (values without measurable load)
High point marking	R R _i R _a	Marks the highest point of radial runout (the greatest wall thickness) for inner and outer ring like R, but only for inner ring like R, but only for outer ring
Bearing sets	DF DB DT	X arrangement O arrangement Tandem arrangement
Lubrication	- GLY32	ungreased Lubricant identifier, e.g. Klüber Asonic GLY 32

GMN High precision deep groove ball bearings Bearing data

- Bore diameter 5 to 40 mm
- Boundary dimensions
- Ball data
- Dimensions
- Abutment dimensions
- Weight
- Load rating
- Speed value (grease lubrication)

Bearing data

Bore diameter 5 to 8 mm

Symbol explanations

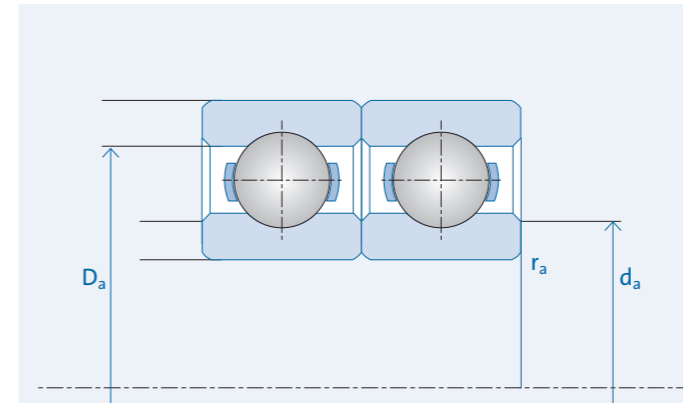
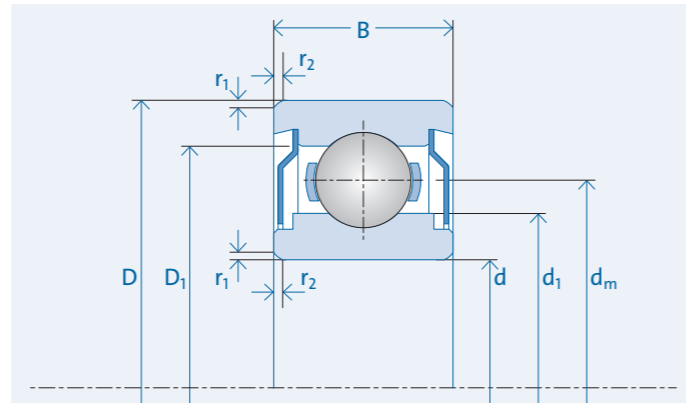
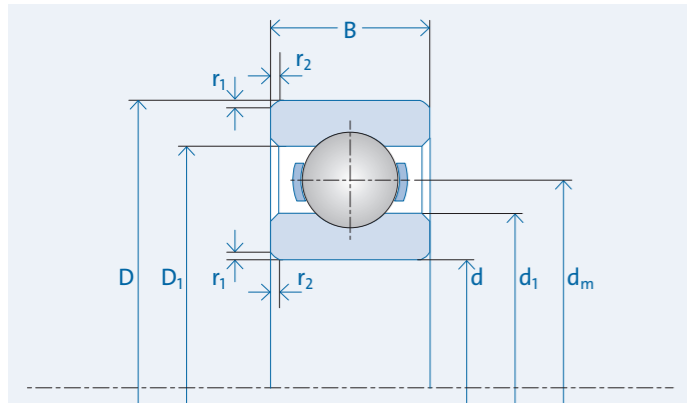

Boundary dimensions

d	[mm]	Bore diameter
D	[mm]	Outer diameter
B	[mm]	Width of single bearing

Balls

dm	[mm]	Pitch circle diameter
Dw	[mm]	Ball diameter
Z	pieces	Number of balls

Dimensions

d1	[mm]	Outer diameter of inner ring
D1	[mm]	Inner diameter of outer ring
r1,2	[mm]	Chamfer (min)

Abutment dimensions

ra max	[mm]	Undercut of associated component
da min	[mm]	Abutment diameter inner ring
Da max	[mm]	Abutment diameter outer ring

m [kg] Bearing weight

Load ratings

C	[N]	Dynamic load rating
C0	[N]	Static load rating, steel balls
C0 HY	[N]	Static load rating, Si ₃ N ₄ balls

n_{grease} [1/min] Speed with grease lubrication and sheet steel cage

Designation	Boundary dimensions			Balls			Dimensions			Abutment dimensions			Weight	Load rating			Speed value	Designation
	d	D	B	dm	Dw	Z	d1	D1	r1,2	ra max	da min	Da max	m	C	C0	C0 HY	n _{grease}	
5 mm																		
625	5	16	5	10.0	3.175	6	7.65	12.50	0.3	0.3	7.5	13.5	0.005	1760	615	435	46000	625
6 mm																		
626	6	19	6	13.3	3.175	8	10.70	15.80	0.3	0.3	9.0	16.5	0.008	2280	950	670	43000	626
7 mm																		
607	7	19	6	13.3	3.175	8	10.70	15.80	0.3	0.3	9.5	16.5	0.008	2280	950	670	43000	607
627	7	22	7	14.7	3.969	7	11.80	17.60	0.3	0.3	10.0	19.0	0.012	2950	1160	810	40500	627
8 mm																		
608	8	22	7	14.7	3.969	7	11.80	17.60	0.3	0.3	10.5	19.0	0.012	2950	1160	810	40500	608
608 X - 2Z	8	22	10,312	14.7	3.969	7	10.50	19.00	0.3	0.3	10.5	19.0	0.014	2950	1160	810	40500	608 X - 2Z

9 to 40 mm

Designation	Boundary dimensions			Balls			Dimensions			Abutment dimensions			Weight m	Load rating			Speed value n _{grease}	Designation
	d	D	B	d _m	D _W	Z	d ₁	D ₁	r _{1,2}	r _{a max}	d _{amin}	D _{a max}		C	C ₀	C _{0 HY}		
9 mm																		
609	9	24	7	16.7	3.969	8	13.45	19.90	0.3	0.3	11.5	21.0	0.023	3300	1390	980	37000	609
629	9	26	8	18.0	4.762	7	14.65	21.40	0.3	0.3	13.0	23.0	0.020	4350	1850	1300	35000	629
10 mm																		
6000	10	26	8	18.0	4.762	7	14.65	21.40	0.3	0.3	12.5	23.0	0.019	4350	1850	1300	34500	6000
6200	10	30	9	20.0	5.556	7	16.00	24.45	0.6	0.6	14.5	25.5	0.032	6000	2650	1850	31000	6200
12 mm																		
6001	12	28	8	20.0	4.762	8	16.65	23.40	0.3	0.3	14.5	25.0	0.022	4850	2210	1560	31000	6001
6001 X - 2Z	12	28	11.506	20.0	4.762	8	15.00	25.10	0.3	0.3	14.5	25.0	0.027	4850	2210	1560	31000	6001 X - 2Z
6201	12	32	10	22.0	5.953	7	18.30	26.00	0.6	0.6	16.5	27.5	0.037	6650	2950	2070	28000	6201
15 mm																		
6002	15	32	9	23.5	4.762	9	20.15	26.90	0.3	0.3	17.5	29.0	0.030	5300	2650	1860	26500	6002
6202	15	35	11	25.3	5.953	8	21.10	29.00	0.6	0.6	19.5	30.5	0.045	7400	3600	2550	25000	6202
17 mm																		
6003	17	35	10	26.0	4.762	10	22.65	29.40	0.3	0.3	20.0	31.5	0.039	5700	3050	2130	24000	6003
6203	17	40	12	28.5	6.747	8	24.10	32.95	0.6	0.6	21.5	35.0	0.065	9400	4700	3300	22000	6203
20 mm																		
6004	20	42	12	31.0	6.350	9	26.60	35.45	0.6	0.6	25.0	37.0	0.069	9800	5350	3800	20000	6004
6204	20	47	14	33.5	7.938	8	28.50	38.55	1.0	1.0	26.0	41.0	0.106	13900	7400	5200	18000	6204
25 mm																		
6005	25	47	12	36.0	6.350	10	32.20	40.05	0.6	0.6	30.0	42.0	0.080	10400	6250	4400	17000	6005
6205	25	52	15	39.1	7.938	9	34.04	44.05	1.0	1.0	31.0	46.0	0.128	15200	8900	6250	16000	6205
30 mm																		
6006	30	55	13	42.5	7.144	11	38.10	46.95	1.0	1.0	36.0	49.0	0.128	13200	8400	5850	14500	6006
6206	30	62	16	46.0	9.525	9	40.40	52.05	1.0	1.0	36.0	55.0	0.199	20000	11800	8300	13500	6206
35 mm																		
6207	35	72	17	53.5	11.112	9	47.40	60.50	1.0	1.0	43.0	64.0	0.315	28000	17200	12100	11500	6207
40 mm																		
6208	40	80	18	60.0	11.906	9	52.80	67.60	1.0	1.0	48.0	72.0	0.402	29500	18000	12700	10000	6208

Engineering

GMN high precision bearings provide intelligent bearing solutions for peak performance machine components.

The outstanding characteristics of GMN ball bearings are the result of technically sophisticated quality features that attain maximum power limits.

The values stated in the bearing data indicate the performance potential of the individual bearing depending on characteristic design and material properties.

Influences due to operating conditions can affect specific bearing characteristics and cause deviations from the stated bearing data.

There are various measures which can be taken to counteract performance restrictions and improve bearing performance.

- Bearing selection
- Preloading
- Accuracy of associated components
- Lubrication
- Operating conditions

Bearing selection

On the basis of GMN's comprehensive array of products, the specific performance profiles of individual bearing designs can be used to select just the right bearing to meet a given set of requirements.

1. Definition, application

e.g. spindle, motor

2. Requirements profile

Installed location: drawing, space available, bearing arrangement (fixed/floating bearing)

Application profile: precision, rigidity, operating temperature, load capacity, speed, service life, duty cycle

3. Bearing selection

Bearing design (materials, bearing type, series, bearing size, cage)

Precision, contact angle, preload (rigid or with spring)

Installation drawing, fastening, surrounding parts (fits, abutment dimensions)

4. Lubrication

Lubrication: Plan for supply/disposal, quantities/cycles, nozzles or bore holes in outer ring

Grease lubrication: type of grease (viscosity, ndm factor), grease quantity, grease resupply system if required

5. Calculation/verification

Operational bearing loads (radial/axial loads)

Permissible static load

Speed limits

Assessment of extended service life

Assessment of grease consumption period

6. Installation

Associated components: shaft, housing, connecting parts;

Tightening force and torque for bearing fastener

Grease distribution run, re-lubrication or oil supply; noise

Monitoring running smoothness,

Checks of preload force, rigidity

Bearing selection

GMN standard series (characteristics)

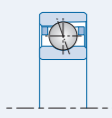
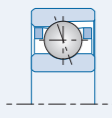
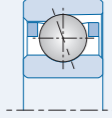
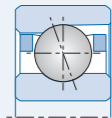
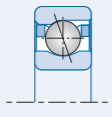
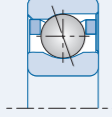
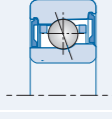
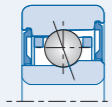
GMN series/bearing sizes		ISO	Characteristics	Applications	
from	to				
GMN series S (standard)					
S 61800 d=10 mm	S 61808 d=40 mm		18	Very thin-walled, very compact size, very smooth (starting) running, high-speed suitability, limited load capacity	e.g. instrumentation
S 619/5 d=5 mm	S 61924 d=120 mm		19	Thin-walled, compact size, very smooth (starting) running, high-speed suitability, medium load capacity,	General purpose, e.g. precision precision tools, tool making machine spindles with moderate loads
S 605 d=5 mm	S 6024 d=120 mm		10	smooth (starting) running, good ratio to load capacity and speed	General purpose, e.g. precision tools, tool making machine spindles with large loads
S 625 d=5 mm	S 6213 d=65 mm		02	Thick-walled, very high load capacity, limited speed suitability	aircraft generators/starters, tool making machine spindles, high load capacity, limited speed
GMN series SM (high speed)					
SM 61900 d=10 mm	SM 61924 d=120 mm		19	Speed suitability about 20% higher, less load capacity*, good compensation for temperature differences between inner and outer rings	High speed precision tools, tool making machine spindles, moderate load capacity
SM 605 d=10 mm	SM 6024 d=120 mm		10	Speed suitability about 20% higher, less load capacity*, good compensation for temperature differences between inner and outer rings	High frequency (HF) spindles for grinding and milling
GMN series KH (highest speed)					
KH 61900 d=10 mm	KH 61914 d=70 mm		19	Speed suitability about 25% higher, less load capacity*, with seal and lifetime lubrication or open for oil lubrication	Spindles for woodworking, bearing covered
KH 6000 d=10 mm	KH 6014 d=70 mm		10	Speed suitability about 25% higher, less load capacity*, with seal and lifetime lubrication or open for oil lubrication	Ultra high frequency spindles for grinding, open bearing, Oil lubrication

*(in comparison to GMN series S)

GMN ball bearings (performance comparison)

GMN has developed various bearing series that exhibit optimized characteristics with respect to individual performance features (e.g. speed, load rating, axial or radial rigidity).

GMN has reliable and durable ball bearing solutions at its disposal with outstanding performance features that fulfill versatile requirement profiles.

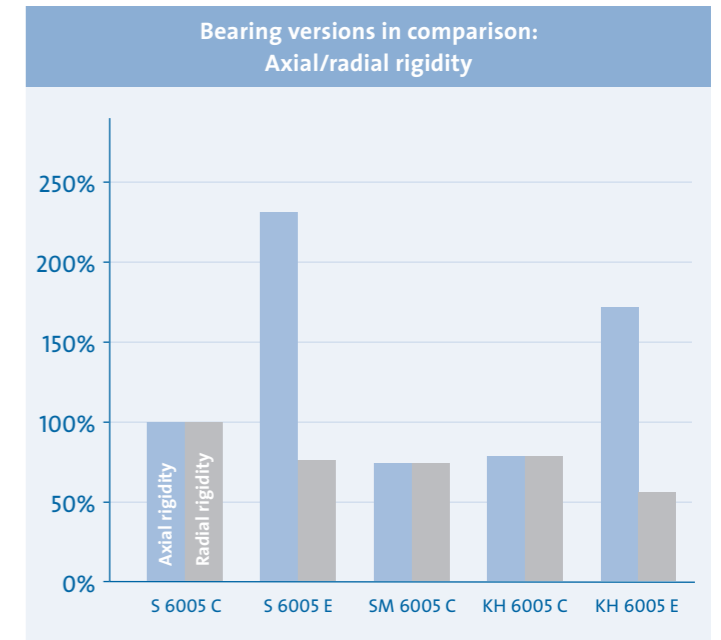
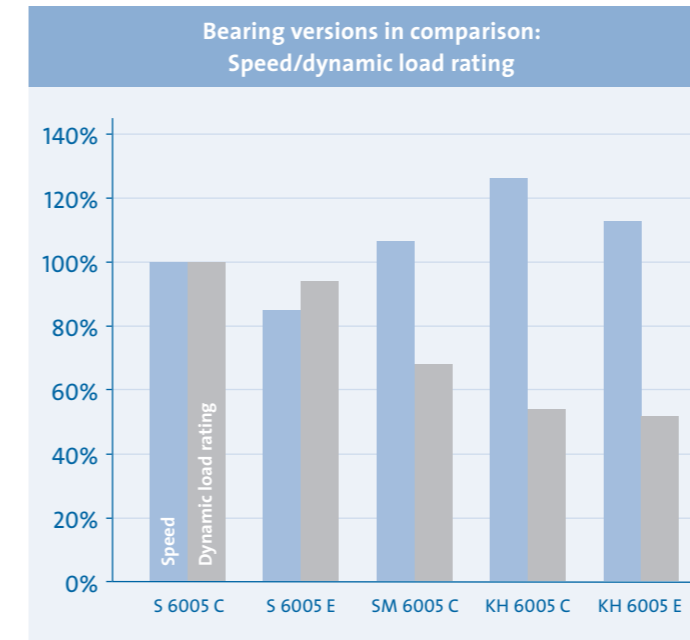

Preload

Preload is defined as a continuously acting axial force exerted on a ball bearing which produces elastic deformation in the contact area of balls and raceways.

The installation of ball bearings with rigid or with spring preload optimizes numerous performance characteristics for bearing operation.

- **Reduced spring action** establishes definable radial and axial rigidity (see diagram)
- **High running accuracy/processing accuracy** even under changing load conditions
- **Reduced vibrations** and running noise
- Prevention of slippage and mixed friction for rolling element contact at high speeds and high acceleration
- **Reduced amounts of sliding friction** at high speeds (reduced contact angle change between inner and outer ring)
- **Increase of load capacity** (by external loads and speeds) with longer service life

Rigidity

Rigidity is defined as the magnitude of axial force [N] on a ball bearing which causes the bearing's rings to be displaced toward one another by 1 μm.

Appropriate preload increases bearing rigidity and supports the bearing's loading capacity against applied forces.

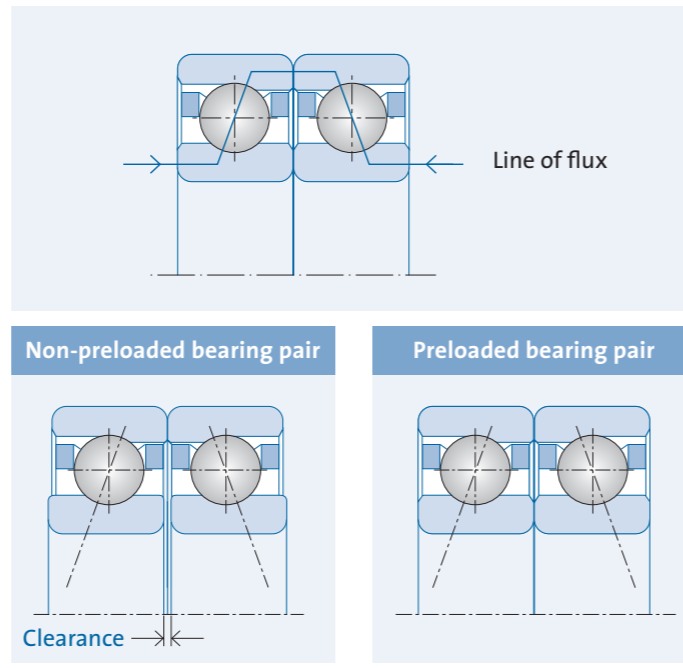
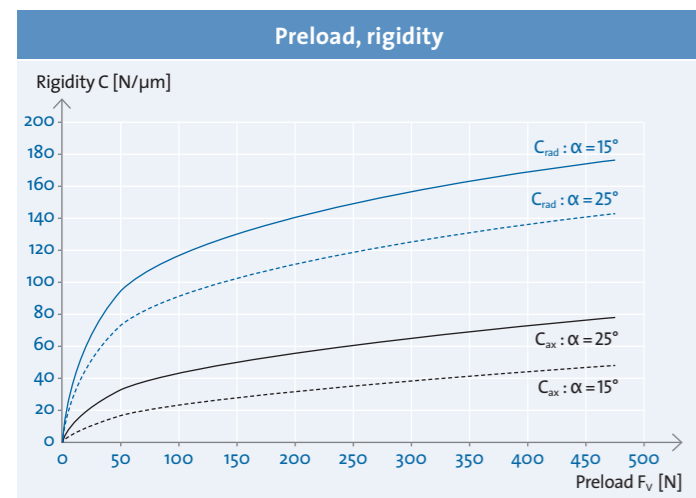

Lift-off force

The force at which a bearing becomes free of load by an axial load acting centrally on a bearing set is defined as lift-off force.

- If the external axial load exceeds the lift-off force ...
- ... balls and raceways of the relieved ball bearing are no longer in permanent contact
- ... wear increases due to increased sliding friction

Spring preloading

Structural features:

- Bearing 1 (work side) is axially fixed in the housing
- Bearing 2 is axially floating (fixed seating position of the inner ring on the shaft)
- The spring force on the outer ring of bearing 2 produces a constant preload on both bearings.
- The required spring preload is adjusted via the spring travel (travel-force function corresponding to the spring characteristic)
- To achieve perfect preload results, sufficient axial freedom of motion is required for the floating bearing's outer ring
- The positioning spring is adjusted in the effective direction of the external axial load
- If single bearings are employed: $\langle \rightarrow \rangle$, these bearings can be unmatched
- If a tandem bearing arrangement is employed, $\langle \langle \rightarrow \rangle \rangle$ matched bearings (L, M or S) ensure uniform load distribution

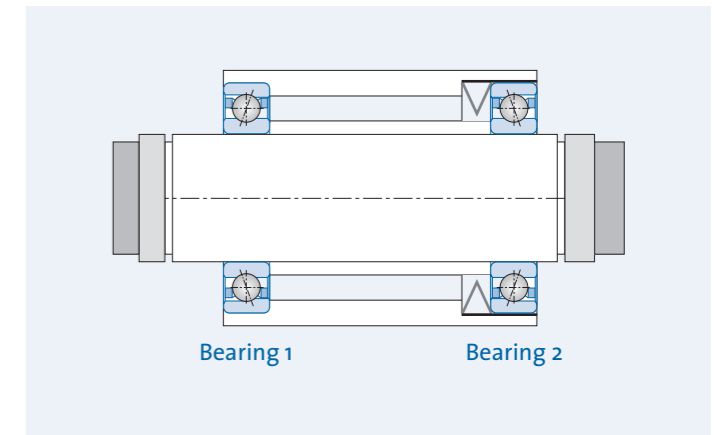

Characteristics:

- The preload results – independent of speed and temperature – exclusively from spring force
- The spring force exerts a constant preload on the bearing and counter bearing
- Thermal expansion of the shaft and housing have no influence on preload
- Spring preloaded bearing systems permit the greatest speeds

Preload

Rigid preload: Single bearings

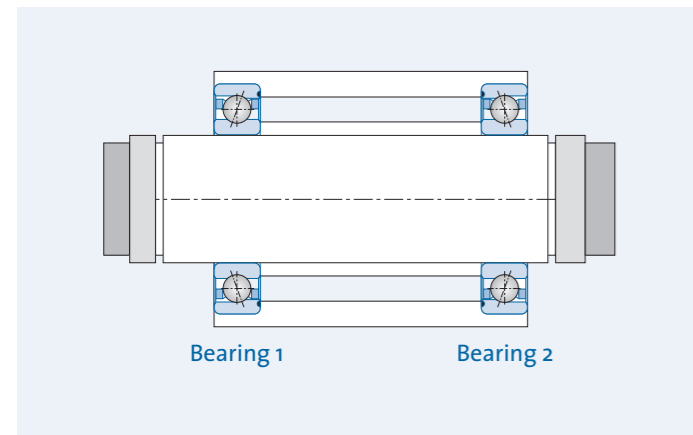

Structural features:

- Bearing 1 (work side) and bearing 2 have axially and radially fixed positions (inner rings sit firmly on the shaft and outer rings in the housing)
- The contact surfaces of associated components to the inner and outer ring have equal length and are plane parallel
- To achieve the predefined preload, it is necessary for the respective bearings to be matched

Characteristics:

- Substantially increased axial and radial rigidity (in comparison to spring preload)
- As friction heat increases as a consequence of increased speed, preload increases to reduce maximum speed (in comparison to spring preload)

The theoretical maximum speed can be calculated on the basis of speed correction factors

- Temperature differences between shaft (inner ring) and housing (outer ring) lead to preload changes due to thermal expansion

If the shaft's temperature is higher than that of the housing, the bearing's radial clearance decreases

Very high temperature differences and small contact angles can cause radial tension

- With small bearing spacing, a temperature gradient from shaft to housing causes an increase of preload
- With large bearing spacing, a temperature gradient from shaft to housing causes a decrease of preload
- The change of preload under operating conditions must be considered in the design

GMN provides software solutions to perform the complex calculation for required bearing preload; these programs embody many years of practical experience which lead to reliable preload results.

Rigid preload: Bearing sets

Multiple arrangements of bearings to form bearing sets increase load capacity, rigidity and lift-off force.

Rigidity and lift-off force

Radial rigidity for all arrangements:
 at $\alpha = 15^\circ$: $C_{rad} \sim 6 \cdot C_{ax}$
 at $\alpha = 25^\circ$: $C_{rad} \sim 2 \cdot C_{ax}$

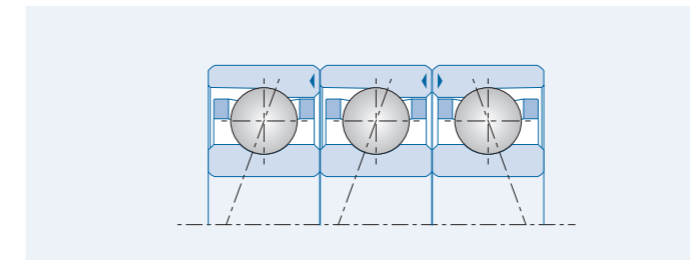

Bearing arrangement		Effective Nominal preload F_V [N]	Axial rigidity C_{ax}^* [N/ μ m]	Lift-off force $F_{a\ max}$ [N]
<> or ><	DB, DF	F_V	C_{ax}	$2.85 \cdot F_V$
<<>	TBT	$1.35 \cdot F_V$	$1.45 \cdot C_{ax}$	$5.65 \cdot F_V$
<<>>	QBC	$2 \cdot F_V$	$2 \cdot C_{ax}$	$5.65 \cdot F_V$
<<<>	QBT	$1.6 \cdot F_V$	$1.8 \cdot C_{ax}$	$8.5 \cdot F_V$

* Reference values for bearing pairs in O or X arrangement (see bearing data). Influences due to operating conditions (e.g. speed, load) are not taken into account.

Bearing arrangements



Bearing pairs (multiple arrangements with 2 bearings)

For rigid bearing preload, matched bearing pairs in O, X or tandem arrangement provide an effective economic and technical solution to a large number of applications.

O arrangement (DB)

Pressure lines diverge in the direction of the bearing's axis

- Wide support base (H) and high rigidity against tilting moments
- Axial force absorption in both directions

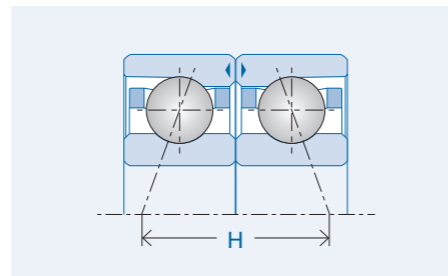

X arrangement (DF)

Pressure lines converge in the direction of the bearing's axis

- Insensitive to misalignment
- Reduced support base size and tilt rigidity
- Axial force absorption in both directions

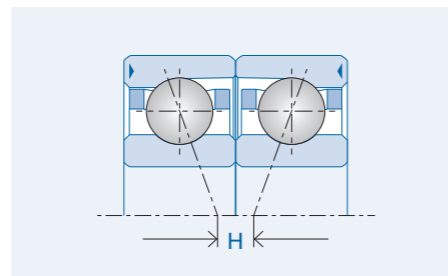

Tandem arrangement (DT)

Arranged parallel to load direction

- Higher axial load capacity (factor 2) than a single bearing
- Both bearings have the same contact angle and are placed against a third bearing

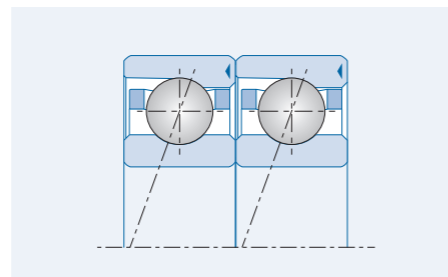

Bearing sets (multiple arrangements with 3 or more bearings)

Where there are maximum demands on system rigidity or high loading, the X, O or Tandem arrangements with 3 or more bearings are able to attain outstanding performance characteristics.

Arrangements with 3 bearings

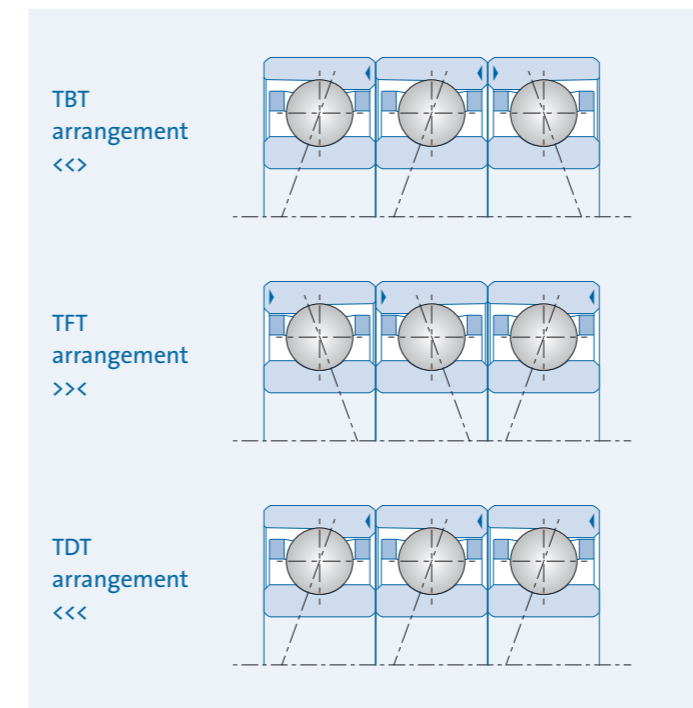

Arrangements with 4 bearings

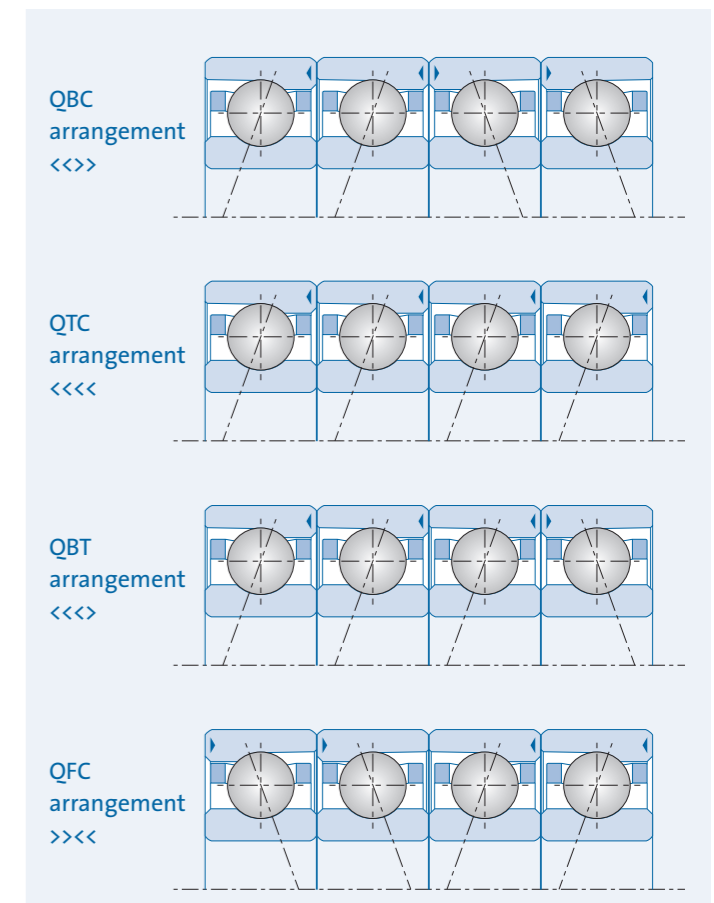

◀ = lettered plane surface on outer ring to identify the bearing arrangement.

Spacers

Contact angle Matching accuracy

Distinct optimization of individual quality features with paired bearings can be achieved by the installation of spacers.

The width of the spacer must be at least as wide as a single bearing.

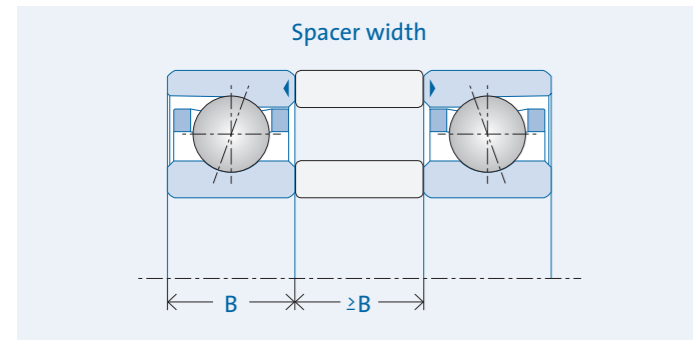

Characteristics:

- Enlarge the support base (H) and increase radial rigidity
- Optimize thermal dissipation
- Improve bearing lubrication by optimized oil flow
- Change of preload with matched bearings is possible
- If the width of the shaft spacer is smaller than the width of the housing spacer then ...
 - ... preload will be increased with the O arrangement
 - ... preload will be decreased with X arrangement
- For bearing sets with spacers (e.g. <||<||>||>), only the spacer between different pressure line courses must be ground off

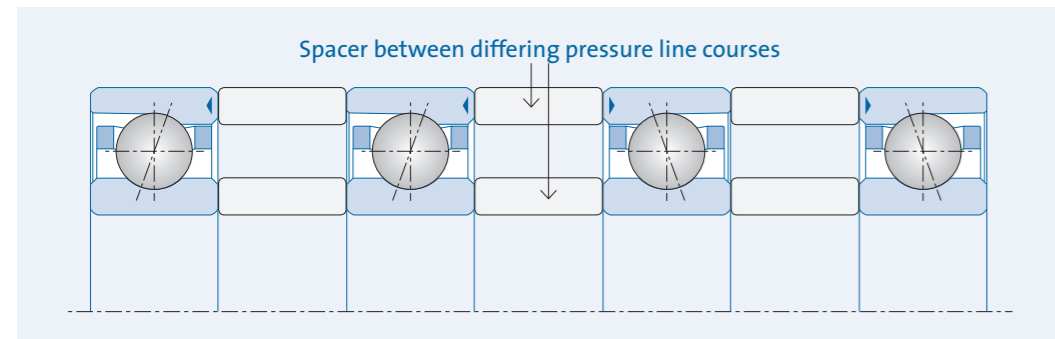

Structural features:

- Material: 100 Cr6, or other, hardened (>=45 HRC)
- The required plane parallelism of outer and inner spacer is guaranteed by surface grinding both rings in one clamping operation

Detailed information on the difference dimension of spacer rings:

www.gmn.de

Contact angle α_0

The angle of the lines between contact points: Inner ring raceway – Ball – Outer ring raceway and the radial plane define the contact angle.

The contact angle is determined by design as a function of radial clearance and the bevel form of the raceways.

Load transmissions between both bearing rings take place over the contact points formed by the raceways and the balls.

Uniform load distribution on individual bearings of bearing arrangements presupposes the same contact angle of all loaded bearings.

The contact angle changes due to operating conditions by ...

- ... external forces
- ... internal forces (centrifugal force of inner ring and balls at high speeds)
- ... inner ring fits
- ... temperature differences between inner and outer ring.

Deviations of the contact angle induce changes in bearing characteristics which influence bearing operation.

With increasing contact angle ...

- ... axial rigidity increases
- ... maximum permissible speed decreases
- ... radial rigidity decreases

Matching accuracy

General matching

The general matching accuracy of $\pm 2 \mu\text{m}$ provides for uniform load absorption and a constant operating temperature in multiple arrangements.

Mated matching

A highly precise matching accuracy of $\pm 1 \mu\text{m}$ (on request) increases the speed suitability of mated matched bearing pairs/sets even further.

Suffix for order designation: X-opt., O-opt. or T-opt.

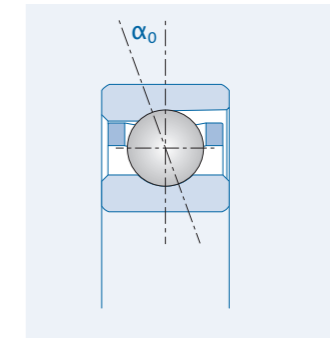

Standard contact angle C (15°) and E (25°)

Deviating contact angles:

GMN bearing designation	Sign	Contact angle
SM 61907 - SM 61911	C	17°
SM 61912 - SM 61924	C	19°
SM 6015 - SM 6024	C	17°
KH 619xx and KH 60xx	C	17°

Other contact angles can be delivered on request.

Precision classes Tolerances

Every high precision ball bearing from GMN is the result of the highest demands on quality – from development through to production.
Minimum tolerances for dimension, shape and running accuracy

permit the highest performance and durability and are specified in international (ISO 492) and national (DIN 620) standards.
GMN high precision ball bearings are manufactured in precision classes P4–P2 as well as ABEC 7–ABEC 9.

Inner ring d Nominal bore diameter [mm]	over including	2.5	10	18	30	50	80
		10	18	30	50	80	120
Inner ring tolerances		(dimensions in μm)					
Δ_{dmp} Deviation of mean bore diameter in one plane	P4	0 / -4.0	0 / -4.0	0 / -5.0	0 / -6.0	0 / -7.0	0 / -8.0
	HG	0 / -3.0	0 / -3.0	0 / -3.0	0 / -5.0	0 / -5.0	-
	UP	0 / -3.0	0 / -3.0	0 / -3.0	0 / -3.0	0 / -4.0	-
	P2	0 / -2.5	0 / -2.5	0 / -2.5	0 / -2.5	0 / -4.0	0 / -5.0
Δ_{D_5} bearing series 60, 62 Difference between a single bore diameter and the nominal value of the bore	P4	0 / -4.0	0 / -4.0	0 / -5.0	0 / -6.0	0 / -7.0	0 / -8.0
	HG	0 / -3.0	0 / -3.0	0 / -3.0	0 / -5.0	0 / -5.0	-
	UP	0 / -3.0	0 / -3.0	0 / -3.0	0 / -3.0	0 / -4.0	-
	P2	0 / -2.5	0 / -2.5	0 / -2.5	0 / -2.5	0 / -4.0	0 / -5.0
$V_{\text{dp max}}$ bearing series ... 618, 619 Difference between largest and smallest bore diameter in one plane – out of roundness	P4	4.0	4.0	5.0	6.0	7.0	8.0
	HG	3.0	3.0	3.0	5.0	5.0	-
	UP	3.0	3.0	3.0	3.0	4.0	-
	P2	2.5	2.5	2.5	2.5	2.5	5.0
$V_{\text{dp max}}$ bearing series 60, 62 Difference between largest and smallest bore diameter in one plane – out of roundness	P4	3.0	3.0	4.0	5.0	5.0	6.0
	HG	3.0	3.0	3.0	5.0	5.0	-
	UP	3.0	3.0	3.0	3.0	4.0	-
	P2	2.5	2.5	2.5	2.5	4.0	5.0
$V_{\text{dmp max}}$ Difference between largest and smallest mean bore diameter in different planes – conicity	P4	2.0	2.0	2.5	3.0	3.5	4.0
	HG	2.0	2.0	2.0	3.0	3.0	-
	UP	2.0	2.0	2.0	2.0	2.5	-
	P2	1.5	1.5	1.5	1.5	2.0	2.5
$K_{\text{ia max}}$ True running of the inner ring in the assembled bearing – radial runout	P4	2.5	2.5	3.0	4.0	4.0	5.0
	HG	2.0	2.0	2.0	2.0	3.0	-
	UP	1.5	1.5	1.5	2.0	2.0	-
	P2	1.5	1.5	2.5	2.5	2.5	2.5
$S_{\text{d max}}$ Plane running of the face side with respect to the bore – face runout	P4	3.0	3.0	4.0	4.0	5.0	5.0
	HG	3.0	3.0	3.0	4.0	4.0	-
	UP	2.0	2.0	2.0	2.0	2.0	-
	P2	1.5	1.5	1.5	1.5	1.5	2.5
$S_{\text{ia max}}$ Plane running of the face side with respect to the raceway, in the assembled bearing – axial runout	P4	3.0	3.0	4.0	4.0	5.0	5.0
	HG	3.0	3.0	4.0	4.0	4.0	-
	UP	2.0	2.0	2.5	2.5	2.5	-
	P2	1.5	1.5	2.5	2.5	2.5	2.5
Δ_{BS} single bearing Deviation of a single inner ring from nominal dimension – width tolerance	P4	0 / -40	0 / -80	0 / -120	0 / -120	0 / -150	0 / -200
	HG	0 / -40	0 / -80	0 / -120	0 / -120	0 / -150	-
	UP	0 / -25	0 / -80	0 / -120	0 / -120	0 / -150	-
	P2	0 / -40	0 / -80	0 / -120	0 / -120	0 / -150	0 / -200
Δ_{BS} paired bearing Deviation of a single inner ring from nominal dimension – width tolerance	P4	0 / -250	0 / -250	0 / -250	0 / -250	0 / -250	0 / -380
	HG	0 / -250	0 / -250	0 / -250	0 / -250	0 / -250	-
	UP	0 / -250	0 / -250	0 / -250	0 / -250	0 / -250	-
	P2	0 / -250	0 / -250	0 / -250	0 / -250	0 / -250	0 / -380
$V_{\text{BS max}}$ Variation of inner ring width – width variation	P4	2.5	2.5	2.5	3.0	4.0	4.0
	HG	2.0	2.0	2.0	2.0	2.0	-
	UP	2.0	2.0	2.0	2.0	2.0	-
	P2	1.5	1.5	1.5	1.5	1.5	2.5

Comparison of international tolerance standards (tolerance symbols per DIN ISO 1132-1)	ISO 492	DIN 620	ABMA
	class 4	P4	ABEC 7
	class 2	P2	ABEC 9

Outer ring D Nominal outside diameter [mm]	over including	6	18	30	50	80	120	150
		18	30	50	80	120	150	180
Outer ring tolerances		(dimensions in μm)						
Δ_{Dmp} Deviation of mean outside diameter in one plane	P4	0 / -4.0	0 / -5.0	0 / -6.0	0 / -7.0	0 / -8.0	0 / -9.0	0 / -10.0
	HG	0 / -3.0	0 / -3.0	0 / -3.0	0 / -4.0	0 / -4.0	-	-
	UP	0 / -3.0	0 / -3.0	0 / -3.0	0 / -4.0	0 / -4.0	-	-
	P2	0 / -2.5	0 / -4.0	0 / -4.0	0 / -4.0	0 / -5.0	0 / -5.0	0 / -7.0
Δ_{D_5} bearing series 60, 62 Difference between a single outside diameter and nominal value	P4	0 / -4.0	0 / -5.0	0 / -6.0	0 / -7.0	0 / -8.0	0 / -9.0	0 / -10.0
	HG	0 / -3.0	0 / -3.0	0 / -3.0	0 / -4.0	0 / -4.0	-	-
	UP	0 / -3.0	0 / -3.0	0 / -3.0	0 / -4.0	0 / -4.0	-	-
	P2	0 / -2.5	0 / -4.0	0 / -4.0	0 / -4.0	0 / -5.0	0 / -5.0	0 / -7.0
$V_{\text{Dp max}}$ bearing series 618, 619 Difference between largest and smallest outside diameter in one plane – out of roundness	P4	4.0	5.0	6.0	7.0	8.0	9.0	10.0
	HG	2.0	2.0	2.0	4.0	4.0	-	-
	UP	2.0	2.0	2.0	4.0	4.0	-	-
	P2	2.5	4.0	4.0	4.0	5.0	5.0	7.0
$V_{\text{Dp max}}$ bearing series 60, 62 Difference between largest and smallest outside diameter in one plane – out of roundness	P4	3.0	4.0	5.0	5.0	6.0	7.0	8.0
	HG	2.0	2.0	2.0	4.0	4.0	-	-
	UP	2.0	2.0	2.0	4.0	4.0	-	-
	P2	2.5	4.0	4.0	4.0	5.0	5.0	7.0
$V_{\text{Dmp max}}$ Difference between largest and smallest mean outside diameter in different planes – conicity	P4	2.0	2.5	3.0	3.5	4.0	5.0	5.0
	HG	1.0	1.0	1.0	2.0	2.0	-	-
	UP	1.0	1.0	1.0	2.0	2.0	-	-
	P2	1.5	2.0	2.0	2.0	2.5	2.5	3.5
$K_{\text{ea max}}$ True running of the outer ring in the assembled bearing – radial runout	P4	3.0	4.0	5.0	5.0	6.0	7.0	8.0
	HG	2.0	2.0	2.0	3.0	3.0	-	-
	UP	2.0	2.0	2.0	3.0	3.0	-	-
	P2	1.5	2.5	2.5	4.0	5.0	5.0	5.0
$S_{\text{D max}}$ Variation of generatrix gradient with respect to the reference face surface – side runout	P4	4.0	4.0	4.0	4.0	5.0	5.0	5.0
	HG	4.0	4.0	4.0	4.0	5.0	-	-
	UP	2.0	2.0	2.0	2.0	2.5	-	-
	P2	1.5	1.5	1.5	1.5	2.5	2.5	2.5
$S_{\text{ea max}}$ Plane running of the face side with respect to the raceway, in the assembled bearing – axial runout	P4	5.0	5.0	5.0	5.0	6.0	7.0	8.0
	HG	5.0	5.0	5.0	5.0	5.0	-	-
	UP	2.0	2.0	2.0	2.0	2.5	-	-
	P2	1.5	2.5	2.5	4.0	5.0	5.0	5.0
Δ_{CS} single bearing Deviation of a single outer ring width from nominal dimension – width tolerance	P4	Identical with Δ_{BS} of the inner ring of the same bearing						
	HG	Identical with Δ_{BS} of the inner ring of the same bearing						
	UP	Identical with Δ_{BS} of the inner ring of the same bearing						
	P2	Identical with Δ_{BS} of the inner ring of the same bearing						
Δ_{CS} paired bearing Deviation of a single outer ring width from nominal dimension – width tolerance	P4	Identical with Δ_{BS} of the inner ring of the same bearing						
	HG	Identical with Δ_{BS} of the inner ring of the same bearing						
	UP	Identical with Δ_{BS} of the inner ring of the same bearing						
	P2	Identical with Δ_{BS} of the inner ring of the same bearing						
$V_{\text{CS max}}$ Variation of outer ring width – width variation	P4	2.5	2.5	2.5	3.0	4.0	5.0	5.0
	HG	2.0	2.0	2.0	2.0	2.0	-	-
	UP	2.0	2.0	2.0	2.0	2.0	-	-
	P2	1.5	1.5	1.5	1.5	1.5	2.5	2.5

Precision of associated components

Installation preparation

The processing quality of bearing seats and the precision of the selected fits decisively influence the performance of the installed bearing.

Operational availability of maximum ball bearing performance increases with the precision of the relevant machine environment.

Careful installation preparations on decisive machine components ensure necessary surface quality and guarantee compliance with the tolerances for shape and position of bearing seats.

Long-term and extensive practical experience has revealed specific guidelines with respect to necessary precision tolerances for associated components that will permit optimal bearing utilization.

Optimization of the fit at high speeds

With increasing speeds (from about $n \cdot d m = 1.5 \cdot 10^6 \text{ mm/min}$) progressively rising centrifugal force can cause widening of the inner ring and lead to the following functional impairments.

- Inner ring slippage on the shaft and contact surfaces
- Fretting corrosion
- Vibrations

A tighter fit is recommended to prevent the inner ring from lifting off.

Guidelines for shaft and housing fits / shape and position tolerances (DIN EN ISO 1101)

Shaft		[mm] over including	[μm]							
Nominal diameter d			3	6	10	18	30	50	80	120
Dimensions			+2 -2	+2 -2	+3 -3	+3 -3	+4 -4	+4 -4	+5 -5	
Cylindricity		t ₁	1	1	1.2	1.5	1.2	2	2.5	
Axial runout		t ₂	1	1	1.2	1.5	1.2	2	2.5	
Concentricity		t ₃	1	1	1.2	1.5	1.2	2	2.5	
Mean surface roughness	R _a	R _a	0.2	0.2	0.2	0.2	0.2	0.2	0.2	

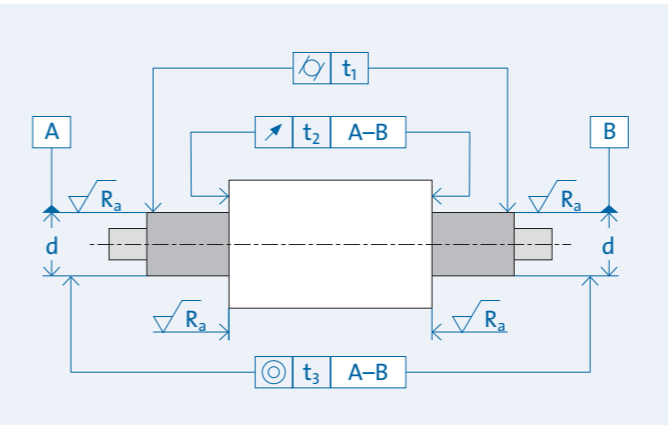

Housing		[mm] over including	[μm]					
Nominal diameter D			10	18	30	50	80	120
Dimensions			+5	+6	+7	+8	+9	+9
Fixed bearings			+0	+0	+0	+0	+0	+0
Dimensions			+7	+8	+9	+10	+11	+12
Floating bearing			+2	+2	+3	+3	+4	+4
Cylindricity		t ₁	1.2	1.5	1.5	2	2.5	3.5
Axial runout		t ₂	1.2	1.5	1.5	2	2.5	3.5
Concentricity		t ₃	1.2	1.5	1.5	2	2.5	3.5
Mean surface roughness	R _a	R _a	0.4	0.4	0.4	0.4	0.4	0.4

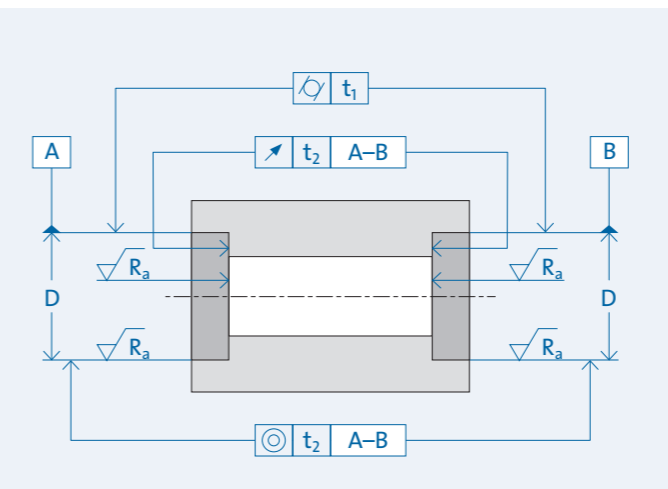

Bore code	Bore diameter d [mm]	Recommended interference [μm] at n · dm factor [· 10 ⁶ mm/min]				
		1.5	1.75	2.0	2.25	2.5
00	10	1	1	2	2	3
01	12	1	2	2	3	4
02	15	2	2	3	4	5
03	17	2	3	4	5	6
04	20	2	3	4	5	6
05	25	3	4	5	7	9
06	30	4	5	7	8	10
07	35	4	6	8	10	12
08	40	5	7	9	12	15
09	45	6	8	11	13	17
10	50	7	9	12	15	19
11	55	8	10	13	17	21
12	60	8	11	15	19	23
13	65	9	13	16	21	26
14	70	10	13	17	21	26
15	75	10	14	18	23	29
16	80	11	15	19	25	30
17	85	12	16	21	26	33
18	90	12	17	22	28	34
19	95	13	18	23	30	37
20	100	14	19	25	31	39
21	105	15	20	26	33	41
22	110	15	21	27	34	42
24	120	17	23	30	38	47

Valid for solid shaft
For hollow shaft (50%): Correction factor = 0.8

Correction factors for interference of bearing types and bearing series	
SM 60..	1
SM 619..	1.10
KH 60..	1.05
KH 619..	1.15

Bearing lubrication

Grease lubrication

Lubricant selection

In order to fully exploit the performance capacity of GMN high precision bearings in machine operation, it is especially important to consider suitable bearing lubrication.

Maximum speeds as well as maximum service life are based on the formation of a friction-reducing lubricant film between rolling and sliding bearing parts.

Other objectives of lubrication are:

- Attenuation of structure noise and vibrations
- Thermal dissipation
- Sealing effect
- Corrosion protection

The increasing speed viability of modern high-speed lubricants permits greater utilization of the user-friendly, economic advantages of grease lubrication.

Operational requirements which exceed the performance capability of grease lubricants can be handled by oil-lubricated bearings to obtain maximum service life at the highest speed and temperature ranges.

Criteria for lubrication type selection

Lubricant	Grease	Oil
Speed suitability up to about $n \cdot d_m$ [10 ⁶ mm/min]	+++ 2.0	+++++ 3-4
Service life	+++	+++++
Design/system costs	+++++	+
Operating costs	+++++	+
Heat dissipation	++	++++
Running in procedure	++	++++
Pollution	+++++	+

+++++: very good · +: poor

Speed suitability of greases

Selection of a suitable grease for high precision bearings is essentially based on the bearing's maximum operating speed.

The reference speed factor, $n \cdot d_m$, accommodates the operational speed of the bearing and indicates the maximum speed capacity of the lubricant sought.

Accommodation of the speed factor when selecting a lubricant precludes degradation of bearing performance due to deficient lubrication.

A speed-induced break-down of the lubrication film can lead to mixed friction, heating, and increased wear on the bearing.

Reference speed factor: $n \cdot d_m$

$$n \cdot d_m \text{ bearing} = n \cdot (D + d)/2 \text{ [mm/min]}$$

n: Bearing operating speed [1/min]

d: Bearing bore diameter [mm]

D: Bearing outer diameter [mm]

Numerous lubricant manufacturers offer a comprehensive range of greases developed for use with high speed or heavily loaded ball bearings.

Particular characteristics, such as protection against wear, low noise level and temperature resistance, are specifically emphasized during production by an application-oriented combination or processing of the base oil, thickener and additives.

Frequently used greases										
Manufacturer Designation	Thickener	Base oil	Density at 20° C [g/ml]	GMN density group	Consistence class DIN 51818 [NLGI]	Kinematic viscosity of base oil DIN 515 [mm ² /s]		Operational temperature range [°C]	n · d _m [mm/min]	Comments on application
						40° C	100° C			
LUBCON TURMOGREASE Highspeed L 252	Special Lithium	Ester + synth. hydrocarbon	0.94	II	2/3	25	6	-40 to +120	2 200 000	High speed grease; very good wear protection; especially suitable for hybrid bearings with ceramic balls; good corrosion protection; for bearing diameters d ≥ 30 mm; standard grease in KH bearings
LUBCON TURMOGREASE Highspeed L 182	Special Lithium	Ester + synth. hydrocarbon	0.94	II	2	18	4.5	-70 to +120	2 500 000	High speed grease; very good wear protection; especially suitable for hybrid bearings with ceramic balls; good corrosion protection; where low viscosity is required
LUBCON TURMOGREASE Li 802 EP	Lithium	synth. hydrocarbon + mineral oil	0.87	0	2	82	12.5	-35 to +140	1 000 000	Resistant to corrosion and aging; compatible with non-ferrous metals; good pressure absorption; good long-term stability; low noise
LUBCON TURMOGREASE PU 703	Polyurea	Ester	1.0	III	3	70	10.7	-40 to +180	1 300 000	High temperatures; good protection against corrosion and aging; compatible with elastomers such as FKM/Viton
KLÜBER ASONIC GLY 32	Lithium-	Ester + synth. hydrocarbon	0.94	II	2	25	5	-50 to +140	1 000 000	Suitable for low temperatures; low noise; low frictional moment; standard grease in shielded deep groove ball bearings
KLÜBER ISOFLEX NCA 15	Special calcium	Ester + mineral oil	0.94	II	2	23	4.7	-50 to +120	1 300 000	Very good wear protection; very low frictional moment; especially suitable for hybrid bearings with ceramic balls; good corrosion protection; good resistance to water and media; resistant to aging and oxidation

Grease-lubricated GMN ball bearings

All GMN high precision ball bearings are available greased.

The standard fill volume is 30% (tolerance ±5%) of the free space.

A fill volume of 20–25% is recommended for smooth running.

Long service life is achieved with a 35% grease fill volume.

Bearings without grease are delivered with standard conservation.

The standard grease volume for series KH bearings is 25% (LUBCON TURMOGREASE Highspeed L 252).

Deep groove ball bearings are given a standard grease volume of 30% (KLÜBER ASONIC GLY 32).

Other greases are available on request.

Detailed information about specific grease volume for individual bearing types: www.gmn.de

Grease re-lubrication

Oil lubrication

Position of lubricant supply holes

O arrangement

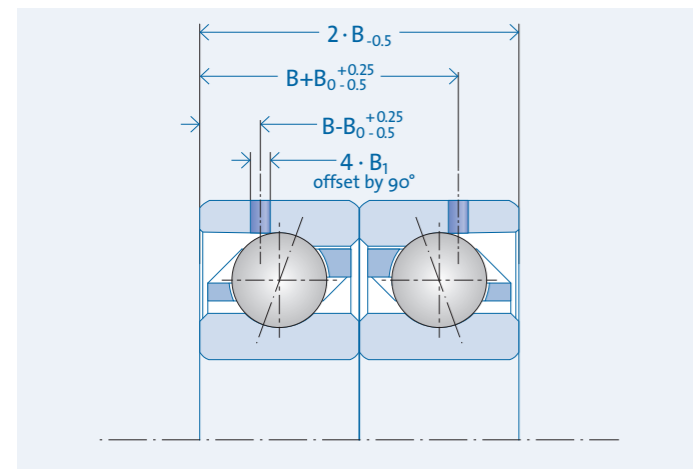

KHAG	B	B ₀ [mm]	ØB ₁
6000	8	5.5	1.5
6001	8	5.5	1.5
6002	9	6.1	1.5
6003	10	6.6	1.5
6004	12	8.1	2.0
6005	12	8.1	2.0
6006	13	8.6	2.0
6007	14	9.2	2.0
6008	15	9.7	2.0
6009	16	10.2	2.0
6010	16	10.3	2.0
6011	18	11.5	2.0
6012	18	11.5	2.0
6013	18	11.5	2.0
6014	20	12.7	2.0

KHAG	B	B ₀ [mm]	ØB ₁
61904	9	6.2	1.5
61905	9	6.2	1.5
61906	9	6.2	1.5
61907	10	6.7	1.5
61908	12	8.1	2.0
61909	12	8.1	2.0
61910	12	8.1	2.0
61911	13	8.7	2.0
61912	13	8.7	2.0
61913	13	8.7	2.0
61914	16	10.3	2.0

Tandem arrangement

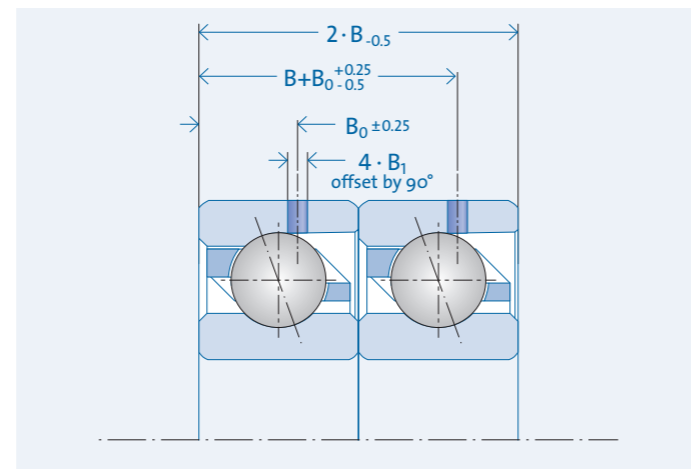

S/SMAG	B	B ₀ [mm]	ØB ₁
6000	8	5.9	1.5
6001	8	5.9	1.5
6002	9	6.4	1.5
6003	10	6.9	1.5
6004	12	8.0	2.0
6005	12	8.0	2.0
6006	13	8.7	2.0
6007	14	9.2	2.0
6008	15	9.8	2.0
6009	16	10.3	2.0
6010	16	10.4	2.0
6011	18	11.4	2.0
6012	18	11.5	2.0
6013	18	11.5	2.0
6014	20	12.8	2.0
6015	20	12.6	2.0
6016	22	13.7	2.0
6017	22	13.7	2.0
6018	24	14.9	2.0
6019	24	14.9	2.0
6020	24	14.9	2.0
6021	26	16.0	2.0
6022	28	17.1	2.0
6024	28	17.1	2.0

B= bearing width (single bearing)
 B₀= Axial distance to shielded side
 ØB₁ = Bore diameter

Other types/sizes on request.

SAG	B	B ₀ [mm]	ØB ₁
61904	9	6.2	1.5
61905	9	6.2	1.5
61906	9	6.2	1.5
61907	10	6.8	1.5
61908	12	8.1	2.0
61909	12	8.2	2.0
61910	12	8.2	2.0
61911	13	8.8	2.0
61912	13	8.8	2.0
61913	13	8.8	2.0
61914	16	10.4	2.0
61915	16	10.3	2.0
61916	16	10.5	2.0
61917	18	11.5	2.0
61918	18	11.5	2.0
61919	18	11.5	2.0
61920	20	12.7	2.0
61921	20	12.7	2.0
61922	20	12.7	2.0
61924	22	13.8	2.0

Oil lubrication systems

Compared to grease-lubricated bearings, the application of lubricating oils enables long-term reliable operation at maximum speeds.

Different methods are available for the supply of oil to high speed bearings:

- Oil air lubrication (minimum quantity lubrication)
- Oil injection lubrication
- Oil fog lubrication

Oil air lubrication

Oil air lubrication provides specific as well as volume-regulated lubricant delivery to the rolling and sliding surfaces in the bearing.

The oil is transported by means of an air stream that form streaks along the inner wall of the transparent supply hose and released uniformly at lubricating points in specified intervals.

Oil air lubrication guarantees utmost effectiveness with respect to consumption and lubricating effect at maximum speeds:

- Reduced flexing work
- Minimum friction losses
- Reduced heat generation
- High operating security
- Specific, volume-regulated lubricant supply
- Low oil consumption
- Low oil fog formation
- Very good lubricating effect
- Environmentally friendly and highly economical
- Oil cooling and oil filtering not required (in comparison to oil injection lubrication)

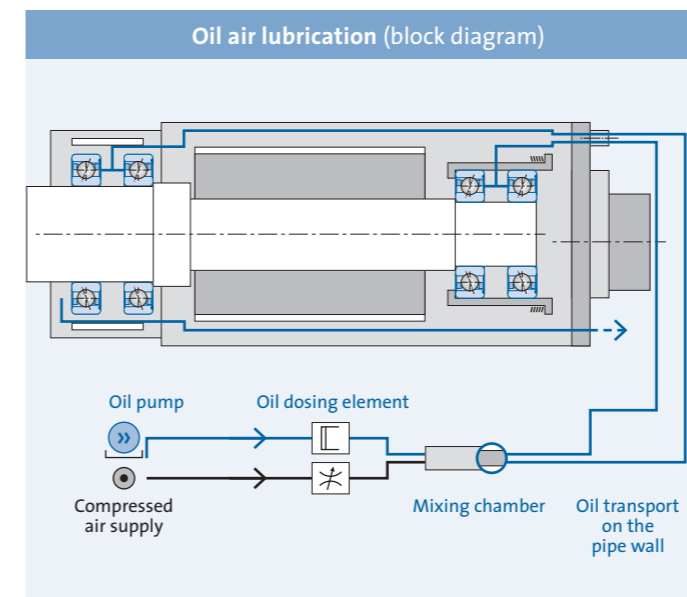

Oil lubrication

Oil supply

Conventional bearing lubrication systems have oil injection nozzles in an intermediate sleeve or in a spacer between 2 bearings.

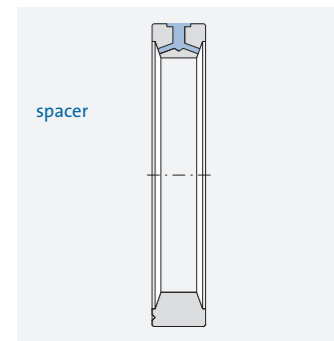

A nozzle position aligned parallel to the spindle axis is sufficient for applications in high speed ranges.
A nozzle position aligned at an angle increases bearing speed suitability (more accurate lubricant supply in the rolling area).

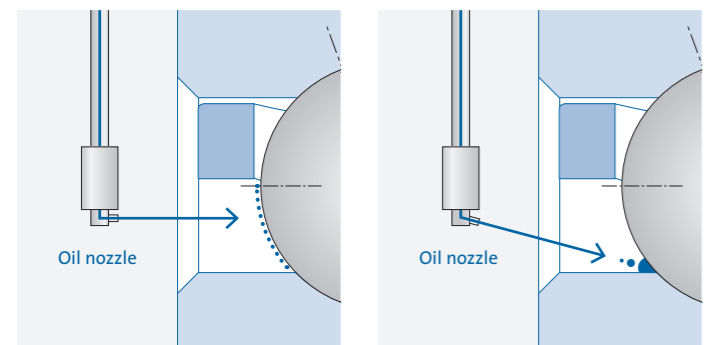

Length and bore diameter of the oil nozzle:
Sufficient lubricant supply is assured with a ratio of nozzle length/ nozzle bore diameter of more than 3 and less than 5 (pressure of oil air current greater than opposing pressure generated by bearing turbulences).

Oil for high precision spindles:
Hydraulic oil with kinematic viscosity VG 32 or VG 46 mm²/s

Oil filtering:
Purity class 13/10 per ISO 4406:99 (particle size < 5 μm)

Oil volume per lubrication pulse:
30 up to 35 mm³ per connection for 1 or 2 bearings

Cycle time:
VG32: 2 to 4 min., VG46: 4–10 min. (independent of d_{bearing})

Number of nozzles:
1 per bearing

Nozzle diameter:
1.2 mm (d_{bearing} < 50 mm) 1.6 mm (d_{bearing} > 70 mm)

Nozzle position:
Between cage and inner ring rim (technical data tables, TA cage)

Oil supply, oil drain:
Transparent hose, d_i = 4 mm

Air pressure upstream of spindle:
0,6 to 1 bar

Air volume:
3 to 4 m³/h (50 to 65 L/min)

Air quality:
Meets ISO 8573: particle size < 5 μm, particle concentration < 5 mg/m³, dew point < 3° C, oil concentration < 1mg/m³

Start-up:
Spindle start-up only after oil supply is secured

Comparison: oil air lubrication / direct oil air lubrication

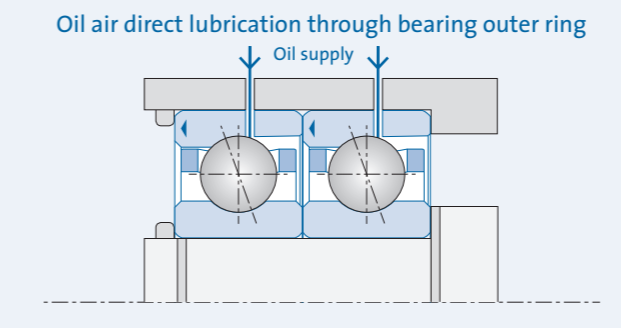
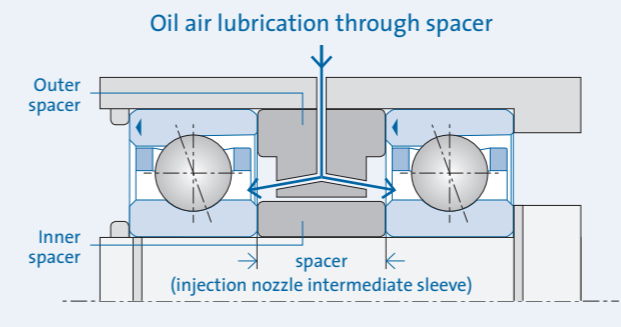

Direct oil lubrication

GMN special designs for direct oil lubrication enable compact bearing dimensions because of an oil supply bore in the outer ring (no spacer for oil supply required) which also permits economical lubricant regulation.

- saves installation space and costs (no axial injection nozzle/intermediate sleeve required)
- Reduced consumption of compressed air and oil (better dosage of lubricant volume)
- Separate lubricant volume regulation per single bearing
- Specific lubricant supply to roller contact points
- Less sensitive to axial air current (in comparison to conventional oil air lubrication)

GMN offers special designs for direct oil lubrication which provide versatile and effective solutions with respect to oil supply and effective sealing.

- Oil supply through outer ring, open side
- Oil supply through outer ring, shielded side
- O-rings in outer ring (sealing)
- Broadened groove for expanded oil supply potential, tolerance compensation

Oil lubrication

Lubricant supply through the outer ring

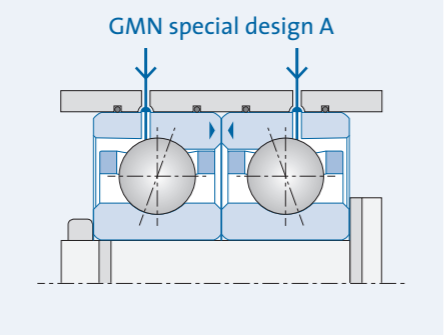
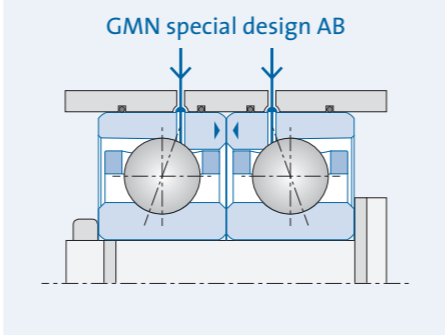
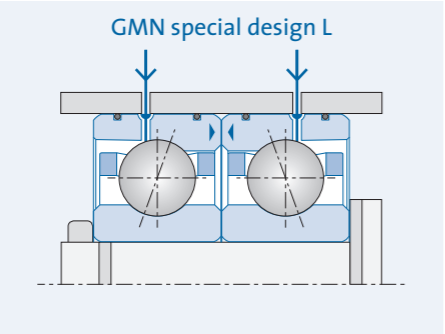
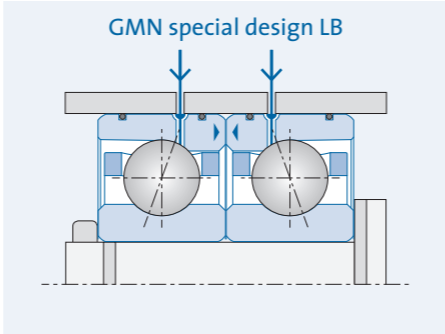
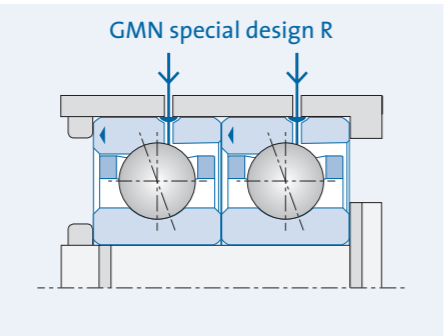
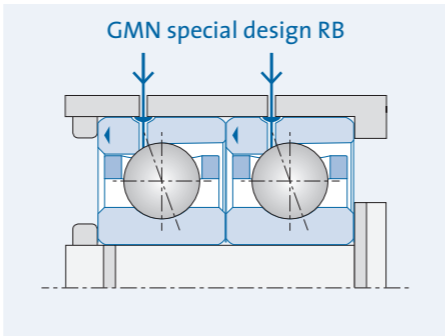
Oil supply/ sealing	Oil supply via open side No overrun of oil supply at high axial loads	Oil supply via closed side Oil supply directly on rolling contact Maximum speed suitability
Special designs A, AB Seal in the housing · Maximum bearing stability	 <p>GMN special design A</p>	 <p>GMN special design AB</p>
Special designs L, LB Seal in bearing outer ring · No housing adaptation required	 <p>GMN special design L</p>	 <p>GMN special design LB</p>
Special designs R, RB without seal · low capital expenditure · Advantageous for axial fixation on outer ring and narrow housing fits · Wide lubrication groove	 <p>GMN special design R</p>	 <p>GMN special design RB</p>

Detailed information on bearings with lubricant supply through the outer ring:
www.gmn.de

Lubricating oils

Mineral lubricating oils achieve adequate bearing lubrication for the lubrication of machine tool spindles.

Oil type	Operating Pour point [°C]	Flashpoint [°C]	Kinematic viscosity [mm ² /s]		temperature range [°C]	Remarks / Application
			40° C	100° C		
			Mineral	-33		
Mineral	-25	+226	46.0	6.7	-15 to +110	Good wear protection; good corrosion and aging resistance
Synthesis	-60	+220	12.2	3.2	-35 to +130	Low evaporation, particularly at low temperatures, resistant to oxidation and corrosion / gyro bearings
Silicone	-65	+280	60	20	-55 to +200	High and low temperature oil / aerospace and aviation industries, fine mechanics
Ester	-68	+220	14.3	3.7	-50 to +120	Good corrosion and aging resistance, low evaporation / aircraft and instrument bearings

Speed limits

GMN develops ball bearings for highest speed and maximum load to optimize the efficiency and service life of machines. A bearing's speed limit is a decisive quantity. As speed increases, the running friction – and thus bearing temperature – rises progressively in the area of contact surfaces between balls and rings.

The friction generated in the bearing is decisively influenced by:

- Speed
- Bearing load
- Lubricant viscosity
- Lubricant quantity

The speed values provided in the bearing tables are nominal speed limits for a spring-preloaded bearing under normal operating conditions.

- Good heat dissipation
- Low external load
- Rotating inner ring
- Oil air lubrication or oil fog lubrication
- Good shape and positioning accuracy of associated parts
- Good alignment of associated parts
- Good balancing of rotating parts
- Use of suitable oil or grease
- Cleanliness in assembly and operation

If operating conditions deviate from the conditions stated then correction factors must be taken into account. (Correction factors and speed values are only guidelines) GMN stands ready to answer questions about your special application on the basis of its broad experience.

Speed limits: GMN spindle bearings				
Permissible speed = speed value $n \cdot f_{n1} \cdot f_{n2} \cdot f_{n3} \cdot f_{n4}$				
Correction factors				
f_{n1} : lubrication	Grease lubrication (observe $n \cdot dm$ grease factor)	0.75		
	Oil air or oil fog lubrication	1.0		
f_{n2} : bearing arrangement/ pairing	Single bearing with spring preload		Bearing preload	
		1.0	F L M S	
	Rigid preload			
		0.8	0.7	0.5
		0.75	0.6	0.4
		0.7	0.6	0.4
		0.6	0.5	0.3
	0.65	0.5	0.3	
f_{n3} : kinematics	Rotating inner ring	1.0		
	Rotating outer ring	0.6		
f_{n4} : ball material	Steel	1.0		
	Ceramic (Si_3N_4)	1.25		

Speed limits: GMN deep groove ball bearings			
Permissible speed = speed value $n \cdot f_{n1} \cdot f_{n2} \cdot f_{n3} \cdot f_{n4} \cdot f_{n5}$			
Correction factors			
f_{n1} : lubrication	grease lubrication (observe the grease's $n \cdot dm$ factor)		1
	Oil air lubrication		1.25
f_{n2} : cage	J	($n \cdot dm < 625\,000\text{ mm/min}$)	1
	T9H	($n \cdot dm < 1\,400\,000\text{ mm/min}$)	1.6
	TBH	($n \cdot dm < 1\,000\,000\text{ mm/min}$)	1.2
	TA	($n \cdot dm < 1\,600\,000\text{ mm/min}$)	1.8
	TB	($n \cdot dm < 1\,400\,000\text{ mm/min}$)	1.6
f_{n3} : kinematics	rotating inner ring		1.0
	rotating outer ring		0.6
f_{n4} : bearing arrangement/pairing	single bearing with spring preload		1.0
	Pairs per DF, DB, DT, DUA, DUO, DUV		0.8
f_{n5} : ball material	steel		1.0
	ceramic (Si_3N_4)		1.25



Storage

Appropriate storage of GMN products assures their bearing-specific performance features until installation.

- Store bearings in their original packaging
- Protect them from dust and moisture
- Protect them from temperature and moisture fluctuations

Shelf-life of preserved, grease-lubricated ball bearings:
Max. 2 years (in proper storage)

Installation preparation

Careful preparation of the installation environment and relevant components assure unrestricted utilization of GMN ball bearing performance characteristics.

Preparation of the installation environment

- Keep the installation environment clean and free of dust and compressed air
- Have necessary measuring and assembly tools at hand
- Allow all parts to adapt to the prevailing temperature
- Clean associated components
- Check condition and dimensions of associated components

Preparing components

- Unpack ball bearings just before installation
- Do not rinse out ball bearings. Most greases and lubricating oils are entirely compatible with the bearing's preservative oil.

Preparation for grease lubrication:

- Have the necessary type and quantity (precision scales) of grease at hand
- Spread grease on both sides of the balls / raceways with a dosing syringe.

Bearing installation

- Match the dimensions of the bearings and associated components to one another (fits)
- Push or pull ball bearings in the axial direction precisely (do not cant)
- Do not transmit installation force through the balls
- When press fitting, warm the inner ring (maximum 100°C). (note: axial shrinkage due to cooling)

Detailed installation information: www.gmn.de

Grease distribution run

The necessary grease distribution run ensures uniform bearing lubrication and optimally distributes grease in the bearing (grease thickener is purged from the ball rolling area and base oil wets the lubricating point evenly).

- Reduced flexing work
- Low bearing temperature
- Exploitation of the grease's $n \cdot dm$ factor
- High operating security
- Long grease and bearing service life

Notices about grease distribution run

- Avoid external loads
- Accelerate to a fraction of nominal speed in about 20 seconds
- Take into account the type of grease (viscosity) and quantity
- Monitor the development of temperature and noise (at more than 60°C housing temperature or extreme noise: stop grease distribution run and resume after a rest period)
- Smooth running and steady temperature levels confirm a successfully completed grease distribution run

Machine run intervals for grease distribution run

Phase 1

Brief intervals of reduced speed

1. Distribution intervals at $0.33 \cdot n_{max}$

Distribution	Standstill	Distribution	Standstill	Distribution	Standstill	Distribution	Standstill
1 min	2 min	1 min	2 min	1 min	2 min	1 min	2 min

2. Distribution intervals at $0.66 \cdot n_{max}$

1 min	2 min	1 min	2 min	1 min	2 min	1 min	2 min
-------	-------	-------	-------	-------	-------	-------	-------

3. Distribution intervals at $1.0 \cdot n_{max}$

1 min	2 min	1 min	2 min	1 min	2 min	1 min	2 min
-------	-------	-------	-------	-------	-------	-------	-------

Phase 2

Long intervals at maximum speed

Distribution intervals at n_{max}

Distribution	Standstill	Distribution
30 min	5 min	30 min

Tightening torque for precision nuts



The use of «precision nuts» for clamping bearings (sets) promotes optimal utilization of the performance capacity inherent to GMN high precision ball bearings.

Guidelines:

Careful installation with precision nuts prevents contact corrosion caused by micro movements.

- Grind the plane sides of the nut at a right angle to the nut's thread and the shaft to prevent bearing tilt or bending of the shaft (max. 2µm wobble tolerance)
- Lock the precision nut on the shaft (against loosening)
- Intermediate spacers / sleeves must be made plane parallel (max. 2µm)

Sufficient axial clamping force fixes the bearing securely into its specified position and ensures necessary bearing preload, precision and rigidity.

Installation:

- Oil the thread lightly
- Tighten precision nut to 2 to 3 times their REFERENCE torque, loosen them again then tighten them down to their REFERENCE torque (compensation for temperature-induced dimension changes of rings and settling)
- The required pressure bonding of multiple bearings (axially) and necessary defeat of bearing friction resistance by the bearing's press fit on the shaft (radially) is assured by the 2 to 3 times initial tightening torque.

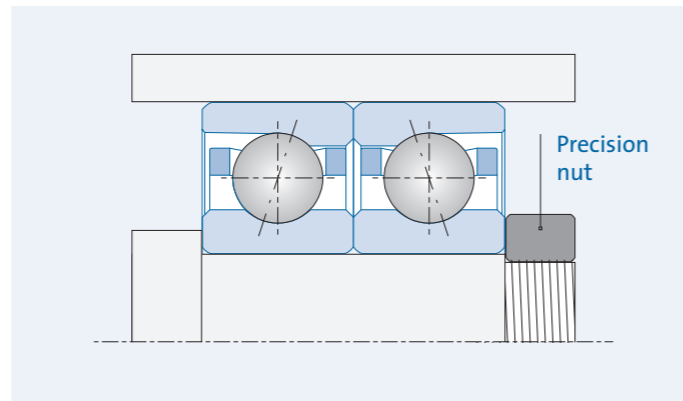

Clamping forces / Tightening torques (guidelines)*

Bore diameter	Bore code number	Clamping force [kN]				Tightening torque [Nm]				Precision nut
		Series				Series				
		618..	619..	60..	62..	618..	619..	60..	62..	
5	5	-	0.6	0.7	0.8	-	0.4	0.5	0.6	M 5x0.5
6	6	-	0.8	0.8	1.4	-	0.7	0.7	1.3	M 6x0.5
7	7	-	0.9	1.1	1.6	-	0.8	1.2	1.6	M 7x0.5
8	8	-	0.9	1.3	-	-	1.0	1.5	-	M 8x0.75
9	9	-	1.0	1.4	1.9	-	1.3	1.9	2.6	M 9x0.75
10	00	1.0	1.1	1.6	2.1	1.4	1.6	2.3	3.1	M 10x0.75
12	01	1.1	1.2	1.6	2.3	1.7	2.0	2.7	4.1	M 12x1
15	02	1.3	1.5	2.0	2.4	2.6	3.0	4.2	5.0	M 15x1
17	03	1.4	1.8	2.4	3.0	3.2	3.9	5.5	7.0	M 17x1
20	04	2.2	2.4	3.1	4.2	5.6	6.4	8.3	15	M 20x1
25	05	2.5	3.1	3.8	4.7	8.2	15	15	20	M 25x1.5
30	06	3.0	3.1	4.5	6.0	15	15	20	25	M 30x1.5
35	07	3.1	4.1	5.0	8.0	15	20	25	40	M 35x1.5
40	08	3.4	4.6	6.5	9.0	20	25	35	50	M 40x1.5
45	09	-	5.5	7.5	9.5	-	30	45	60	M 45x1.5
50	10	-	4.7	8.0	10.0	-	30	50	65	M 50x1.5
55	11	-	6.0	10.0	12.0	-	45	75	90	M 55x2
60	12	-	6.0	11.0	16.0	-	45	85	120	M 60x2
65	13	-	6.0	11.0	19.0	-	50	95	160	M 65x2
70	14	-	9.0	13.0	-	-	80	120	-	M 70x2
75	15	-	9.5	13.0	-	-	90	130	-	M 75x2
80	16	-	9.5	16.0	-	-	95	170	-	M 80x2
85	17	-	13.0	17.0	-	-	140	180	-	M 85x2
90	18	-	13.0	19.0	-	-	150	220	-	M 90x2
95	19	-	13.0	20.0	-	-	160	240	-	M 95x2
100	20	-	16.0	20.0	-	-	210	260	-	M 100x2
105	21	-	17.0	22.0	-	-	220	300	-	M 105x2
110	22	-	17.0	26.0	-	-	230	360	-	M 110x2
120	24	-	21.0	27.0	-	-	310	410	-	M 120x2

* Clamping force values and tightening torques are guidelines based on experience and may deviate according to application.

Bearing calculation

The service life calculation assesses a bearing solution with consideration for bearing material fatigue under defined operating conditions.

Calculation methods per DIN ISO 76 (static load rating) and DIN ISO 281 (dynamic load rating and service life)

GLOBUS bearing calculation program from GMN

GMN offers an option for performing these calculations by running the GLOBUS ball bearing calculation program on a computer; this permits selection of various service life solution options from the comprehensive product line.

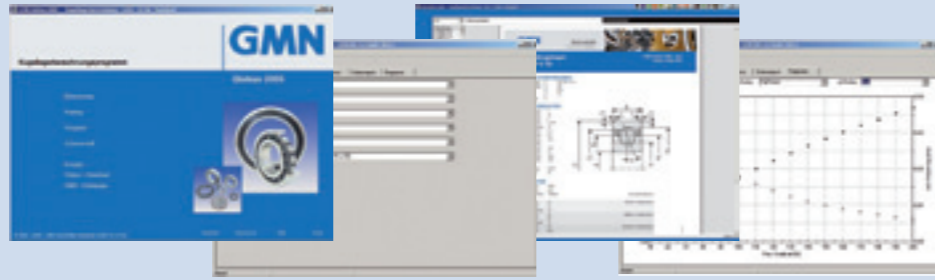

Bearing service life calculation

1. Extended service life L_{nm}

$$L_{nm} = a_1 \cdot f_t \cdot a_{ISO} \cdot L_{10}$$

- a_1 : Factor for the probability of failure
- f_t : Factor for operating temperature
- a_{ISO} : Life adjustment factor → 7.
- L_{10} : Nominal service life [h] → 2.

Failure probability	10%	5%	4%	3%	2%	1%
Factor a_1	1	0.64	0.55	0.47	0.37	0.25

Maximum operating temperature	150°C	200°C	250°C	300°C
Factor f_t	1	0.73	0.42	0.22

2. Nominal service life L_{10}

$$L_{10} = \frac{10^6}{60 \cdot n} \cdot \left(\frac{C}{P}\right)^3 \text{ [h]}$$

- n : Speed [1/min]
- C : Dynamic load rating [N] → 3.
- P : Equivalent bearing load [N] → 5.

3. Dynamic load rating C

for two or more spindle bearings in X, O or Tandem arrangement:

$$C = i^{0.7} \cdot C_{single} \text{ [N]}$$

- i : Number of bearings
- C_{single} : Load rating of single bearing [N]

4. Axial loading F_a

$$F_a = K_a \text{ [N] (if } K_a > 3 \cdot F_V)$$

$$F_a = F_V + 0.67 \cdot K_a \text{ [N] (if } K_a \leq 3 \cdot F_V)$$

- K_a : External axial force [N]
- F_V : Preload [N]

5. Equivalent bearing load P

$$P = X \cdot F_r + Y \cdot F_a \text{ [N]}$$

- F_r, F_a : Radial load, axial load [N] → 4.
- X, Y : Radial factor, axial factor → 6.

Equivalent bearing load is an auxiliary quantity. It serves to account for and standardize various operating conditions and load relationships.

6. X and Y factors

	Relative axial load $i \cdot F_a / C_0$	Single bearing Tandem arrangement				Bearing pair in X or O arrangement				
		e	$F_a/F_r \leq e$		$F_a/F_r > e$		$F_a/F_r \leq e$		$F_a/F_r > e$	
		X	Y	X	Y	X	Y	X	Y	
Spindle bearing										
Contact angle 15°										
	0.015	0.38			1.47			1.65		2.39
	0.029	0.40			1.40			1.57		2.28
	0.058	0.43			1.30			1.46		2.11
	0.087	0.46			1.23			1.38		2.00
	0.120	0.47	1	0	0.44	1.19	1	1.34	0.72	1.93
	0.170	0.50			1.12			1.26		1.82
	0.290	0.55			1.02			1.14		1.66
	0.440	0.56			1.00			1.12		1.63
	0.580	0.56			1.00			1.12		1.63
Contact angle 20°										
		0.57	1	0	0.43	1.00	1	1.09	0.7	1.63
Contact angle 25°										
		0.68	1	0	0.41	0.87	1	0.92	0.67	1.41
Deep groove ball bearings										
Radial clearance CN (p. 49)										
	0.014	0.23			2.30			2.78		3.74
	0.028	0.26			1.99			2.40		3.23
	0.056	0.30			1.71			2.07		2.78
	0.085	0.34			1.55			1.87		2.52
	0.110	0.36	1	0	0.56	1.45	1	1.75	0.78	2.36
	0.170	0.40			1.31			1.58		2.13
	0.280	0.45			1.15			1.39		1.87
	0.420	0.50			1.04			1.26		1.69
	0.560	0.52			1.00			1.21		1.63
Radial clearance C3 (p. 49)										
	0.014	0.29			1.88			2.18		3.06
	0.029	0.32			1.71			1.98		2.78
	0.057	0.36			1.52			1.76		2.47
	0.086	0.38			1.41			1.63		2.29
	0.110	0.40	1	0	0.46	1.34	1	1.55	0.75	2.18
	0.170	0.44			1.23			1.42		2.00
	0.290	0.49			1.10			1.27		1.79
	0.430	0.54			1.01			1.17		1.64
	0.570	0.54			1.00			1.16		1.63

- C_0 : static load rating [N]
- e : Loading ratio: radial/axial load

- F_r, F_a : Radial load, axial load [N]
- X, Y : Radial factor, axial factor

For Tandem arrangement: $i = 1$; C_0 and F_a : Use single bearing values

Bearing calculation

7. Life adjustment factor a_{ISO}

$$a_{ISO} = f\left(\frac{e_c \cdot C_u}{P}, \kappa\right)$$

e_c : Contamination factor → 7.2.

$$C_u = \frac{C_0}{22} \quad \text{for bearings with } d_m \leq 100 \text{ mm}$$

$$C_u = \frac{C_0}{22} \cdot \left(\frac{100}{d_m}\right)^{0.5} \quad \text{for bearings with } d_m > 100 \text{ mm}$$

C_u : Fatigue limit load

P : Equivalent bearing load → 5

(For grease lubrication: v = viscosity of the base oil)

Life adjustment factor a_{ISO}

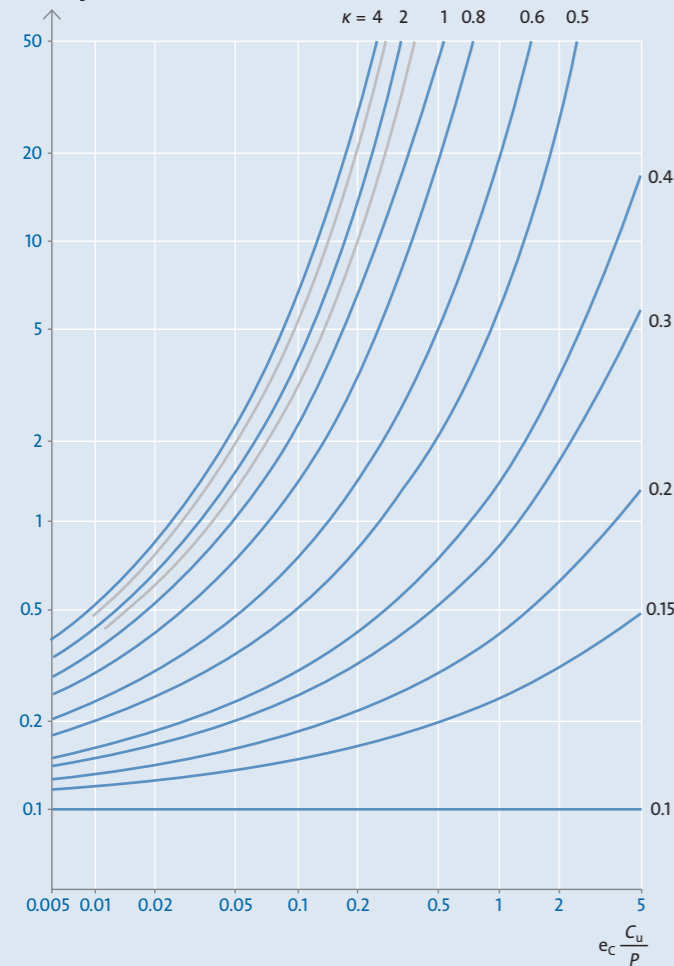

7.1 Viscosity ratio κ

$$\kappa = \frac{v}{v_1}$$

v : Operating viscosity → 7.1.1

v_1 : Reference viscosity → 7.1.2

(good lubrication: $\kappa = 2.5$ to 4.0)

For $\kappa < 0.1$, an extended service life calculation is not possible

7.1.1 Operating viscosity v

$$v(T_b, v_{40}, v_{100}) := v_{40} \cdot e^{\left(\frac{1948.1}{T_b + 273.2} - 6.22\right) \cdot \ln\left(\frac{v_{40}}{v_{100}}\right)}$$

T_b : Operating temperature = $0.6 \dots 130$ [°C]

v_{40} : Lubricant operating viscosity at 40°C

v_{100} : Lubricant operating viscosity at 100°C

(For grease lubrication: v = viscosity of the base oil)

Lubricant (Examples)	Operating viscosity v [cSt] or [mm ² /s]	
	at 40°C	at 100°C
Klueber Isoflex GLY 32	25	5
Lubcon Turmogrease Highspeed L252	25	6
Mineral oil	46	6.8

Operating viscosity [mm²/s]

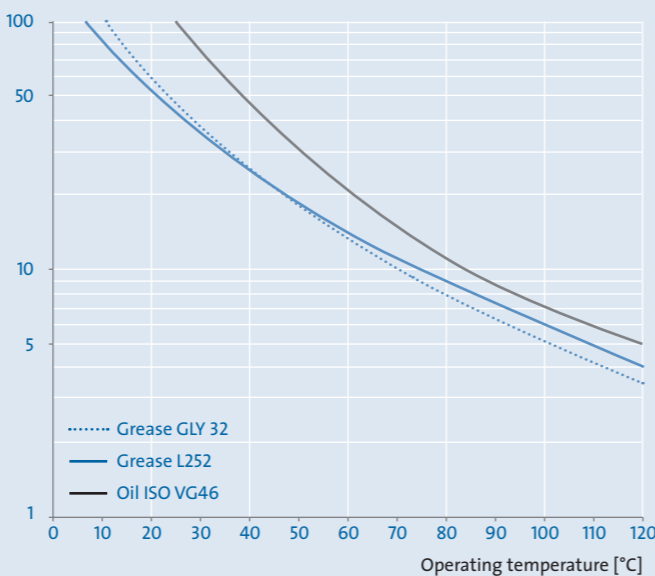

7.1.2 Reference viscosity v_1

Operating viscosity v_1 [mm²/s]

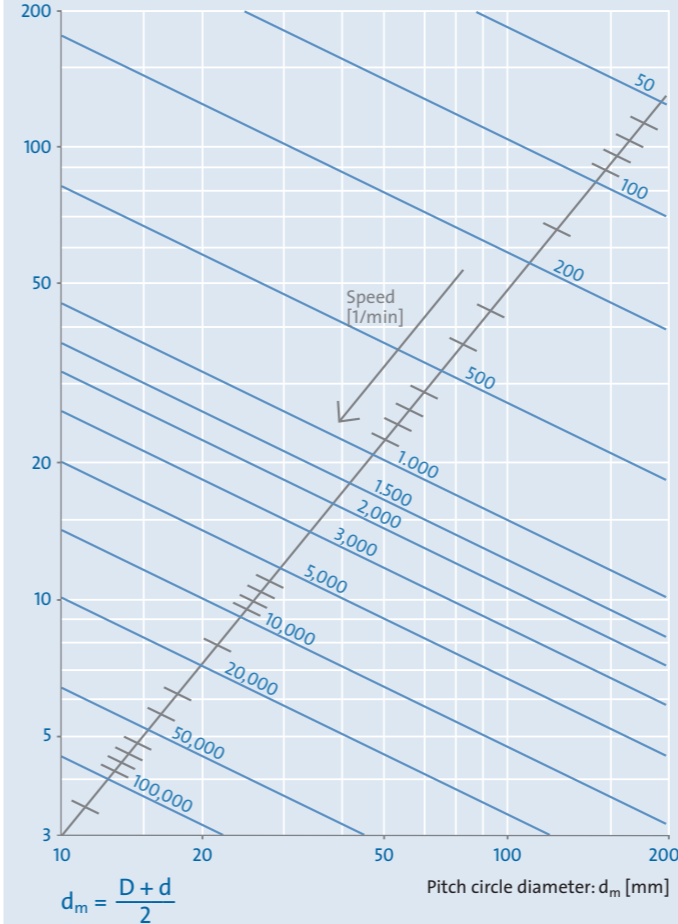

7.2 Contamination factor e_c

Degree of contamination	$d_m < 100$ mm	$d_m \geq 100$ mm
Extreme cleanliness Particle size on the order of magnitude of lubricating film height (laboratory conditions)	1	1
High cleanliness Very fine filtering of the oil supply; typical conditions for a shielded bearing with lifetime grease lubrication	0.8 to 0.6	0.9 to 0.8
Normal cleanliness Oil filtered through a fine filter; typical conditions for a shielded bearing with lifetime grease lubrication	0.6 to 0.5	0.8 to 0.6
Slight contamination Slight contamination in the lubricant	0.5 to 0.3	0.6 to 0.4
Moderate contamination Typical conditions for bearings without an installed seal; rough filtration; wear particles and foreign particles from the environment	0.3 to 0.1	0.4 to 0.2
Severe contamination Bearing environment heavily polluted and bearing arrangement not adequately sealed	0.1 to 0	0.1 to 0
Very severe contamination	0	0

d_m : Pitch circle diameter

Grease service life



Static load capacity

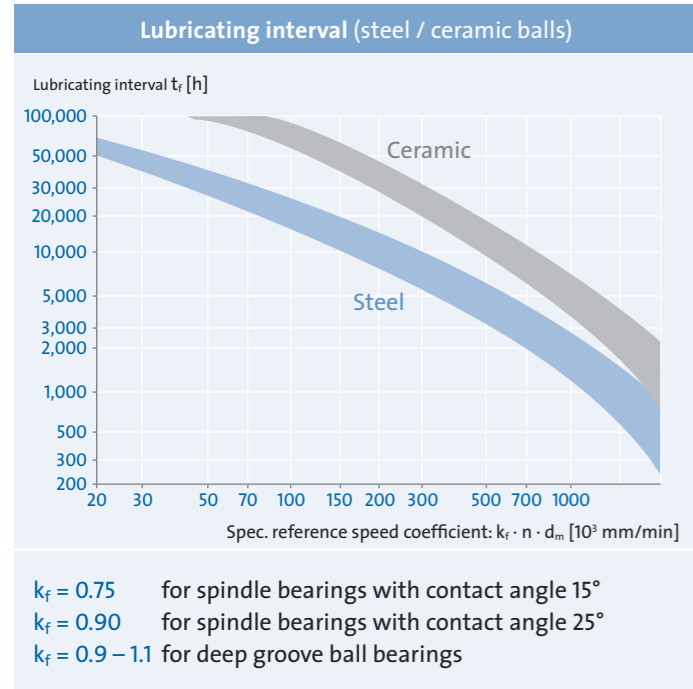

Lubricating interval

Consideration of the required lubricant service life (lubricating interval) is of decisive importance for long-term reliable operation of grease lubricated bearings. Lubricating intervals of more than 5 years are possible under favorable operating conditions.

The calculation of lubricating interval (t_l) is carried out on the basis of lubricant characteristics and operationally-induced bearing loads.

- Grease type, volume and distribution
- Design and bearing type
- Installation conditions (cleanliness)
- Operating conditions (speed, reference speed coefficient, loads, temperature, etc.)

Operating conditions* for lubrication interval reference points t_l

- Standard greases on the basis of lithium saponification
- Operating temperature up to 70°C
- Bearing load ($P/C < 0.1$)
- Favorable ambient conditions with respect to ...

- ... dust
- ... humidity
- ... air currents through the bearing

* (according to GfT Worksheet 3, "Roller Bearing Lubrication", Sept. 2006)

Higher operating temperatures cause a reduction of the lubricating interval. (Beyond an operating temperature of 70°C , a further heat-up of 15°Kelvin will lead to a lubricating interval which is only half the initial period.)

Higher bearing loads ($P/C > 0.1$), jerky loads and vibrations require appropriate corrections to lubricating interval reference values t_l .

If exceptional load conditions prevail, GMN will provide consultation about special greases optimized for the specific requirements.

Sufficient static load capacity ensures the form-stability of bearing components under maximum force influences during operation. Particularly during machine standstill (tool changes) and extremely slow rotation it is possible for high mechanical loads to occur.

The static load capacity (static coefficient f_s) is determined by taking into account the bearing characteristics and operating conditions. Adequate static load capacity of the bearing is given if the static coefficient f_s is greater than 2.5, (no plastic deformation of balls/raceways at the contact point).

Static coefficient f_s

$$f_s = i \cdot C_0 / P_0$$

- i : Number of bearings
- C_0 : Static load rating [N]
- P_0 : Static equivalent load [N]

The static equivalent bearing load P_0 is a reference value which accommodates various operating and load conditions in a standardized manner for use in the calculation of the static coefficient f_s .

Static equivalent load P_0 [N]

$$P_0 = X_0 \cdot F_r + Y_0 \cdot F_a \text{ [N]}$$

if $P_0 < F_r$ then $P_0 = F_r$

- X_0 : Radial factor
- Y_0 : Axial factor
- F_r : Radial force [N]
- F_a : Axial force [N]

The influences of bearing type, contact angle and bearing arrangement on bearing stability are incorporated by way of the radial/axial factors.

	Single bearing		Bearing pair	
	Tandem arrangement		X or O arrangement	
Radial/axial factor	X_0	Y_0	X_0	Y_0
Spindle bearing $\alpha=15^\circ$	0.5	0.46	1	0.92
Spindle bearing $\alpha=25^\circ$	0.5	0.38	1	0.76
Deep groove ball bearing	0.6	0.5	-	-

Bearing frequencies

Service

Structure-borne noise

The design and geometry of the individual components, as well as the design of the entire bearing, determine bearing frequencies. The characteristic structure-borne noise level of a ball bearing is composed of the sum of all bearing frequencies.

Structure-borne noise relevant factors:

- Form accuracy and surface grade of raceways and balls
- Cage version
- Cleanliness and type of lubrication

On the basis of structure-borne noise tests, bearing vibrations can be determined and conclusions drawn about the surface condition (waviness) of bearing rings and balls.

Low noise levels are the result of smooth running and low friction which indicate high performance and long service life of the bearing.

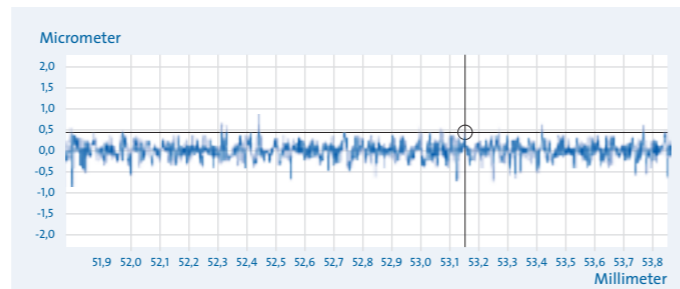

Calculation of bearing-specific frequencies

Ball passing frequency f_{AR} on outer ring:

$$f_{AR} = \frac{Z}{2} \cdot f_i \cdot \left(1 - \frac{D_W}{d_m} \cos \alpha_0\right) [1/\text{sec}]$$

Ball passing frequency f_{IR} on inner ring:

$$f_{IR} = \frac{Z}{2} \cdot f_i \cdot \left(1 + \frac{D_W}{d_m} \cos \alpha_0\right) [1/\text{sec}]$$

Ball circulation frequency f_W :

$$f_W = \frac{f_i}{2} \cdot \left(\frac{d_m}{D_W} - \frac{D_W}{d_m} \cos^2 \alpha_0\right) [1/\text{sec}]$$

Cage frequency f_K :

$$f_K = \frac{f_i}{2} \cdot \left(1 - \frac{D_W}{d_m} \cos \alpha_0\right) [1/\text{sec}]$$

f_i =Shaft frequency [1/s]
 D_W =Ball diameter [mm]
 d_m =Pitch circle diameter [mm]
 Z =Number of balls
 α_0 =Contact angle

Rapid, uncomplicated calculation of bearing-specific frequencies:
www.gmn.de: "GLOBUS 2005"

GMN bearing analysis

More than 50% of all bearing damage results from inadequate lubrication, more than 40% is caused by faulty design, installation defects and contamination.

Less than 1% of all bearings fail due to material or manufacturer defects.

Bearing analyses performed by GMN permit conclusions to be drawn about the causes of impairment and provide solutions which enable reliable operation of the bearing application.

- Assessment of cause(s) of bearing damage or inadequate processing results
- Consultation about cause elimination
- Prevention of same or similar damage
- Optimization of the bearing with respect to machine duty cycle, processing accuracy and performance
- Use of analysis results for product improvements

GMN offers comprehensive investigative methods for bearing analysis.

- Noise test
- Metrological investigation (bearing and component measurements)
- Microscopic investigation (including REM)
- Lubricant analysis
- Calculation review (e.g. check of preload)
- Weak-point analysis

In order to achieve specific and meaningful results in bearing analysis, the following approach should be pursued:

- Remove the bearing immediately after the damage event or operating abnormality
- Mark the installation position (fixed/floating bearing, load direction, drawing/sketch)
- Return the bearing uncleaned with all parts
- Inform us about the application, operating conditions, load, speed and time installed

Consultation

On the basis of long experience in the practical application of machine components, GMN provides comprehensive consultation and services in the field of high precision ball bearings that support machine systems.

- Bearing selection, bearing calculation, service life calculation
- Characteristic values, bearing frequencies, installation dimensions ...
- Tribology, lubrication, lubricant selection, grease consumption life calculation
- Recoding of competitive products
- Optimizations for special applications
- Special solutions
- Damage analysis

Training courses

GMN provides qualified training courses in theory and practice for high precision ball bearings and their applications, both at customer locations and also at our premises. Subjects and contents of training courses are focused on the individual customer requirements.

- Essentials: products, designs, materials, accuracies and tolerances
- Engineering: nomenclature, bearing selection, bearing arrangements, preload, matching, lubrication, calculation
- Installation: workplace layout, tools, control measurements lubrication, installation, grease distribution run
- Bearing analysis: reasons for bearing investigations, methodology, investigation options at GMN

Special applications

GMN develops special bearings and complete solutions that set the technical benchmark for numerous application profiles:

- Touchdown bearings
- Vacuum technology / turbo molecular pumps
- Medical technology / X-ray
- Bearing systems
- Instrument and navigation technology
- Machine tool applications

A global GMN service network offers competent customer consultation and customer-oriented solutions.



Touchdown bearings

- Full complement bearings
- Economic 3-bearing systems for limited installation space
- Robust 4-bearing systems
- High acceleration to final speed
- High number of touchdowns and "touch-and-goes"

Vacuum technology / turbo molecular pumps

- High speeds
- Optimized lubrication
- Long service life
- Low noise level
- Cleanliness
- Materials suitable for vacuum

Medical technology / X-ray

- Dry lubrication
- Temperature insensitive up to 550 °C
- Ultra-high vacuum (10⁻⁷ to 10⁻⁹ mbar)
- No particles or contamination
- Low operating noise
- High surface pressure

Bearing systems

- Production and engineering from a single source
- Low vibration operation
- Optimal adaptation to connection points
- High running accuracy

Instrument and navigation technology

- Maximum running accuracy
- Ready-to-install preloaded bearing systems
- Low frictional moments
- Associated components of utmost precision
- Matched bearings with lifetime lubrication

Machine tool applications

- Special series optimized for specific requirements
- High speeds
- Special materials
- Lifetime lubrication
- Optimized design (radial clearance, matching, special lubrication)

Index

Associated component tolerances	70–71	Deep groove ball bearing cages	48	Hybrid ball bearings	12–13, 47	Sealed bearings	7, 15, 46
Ball bearing tolerances	68–69	· J		Installation	82	Service life calculation	86–90
Bearing analysis	93	· T9H		Internet, downloads	98	Service	93
Bearing arrangements	64–65	· TBH		Lift-off force	60, 63	Service life: grease	90
Bearing comparisons		· TA ; TB		Matching accuracy	67	Shape and position tolerances	71
· GMN series	59	Deep groove ball bearing series 60../62..	7, 46	Materials		Special applications	94–95
· Competition	44	· Z/2Z		· Spindle ball bearings	10–13	Spacers	66
Bearing data		· X-2Z		· Deep groove ball bearings	47–48	Speeds	
· Spindle ball bearings	22–43	Direct lubrication		Model series	9	· Spindle ball bearings	22–43
· Deep groove ball bearings	52–55	· Grease	18, 74	Nut tightening torque	84–85	· Deep groove ball bearings	52–55
Bearing designation		· Oil	16–17, 77–78	Oil lubrication	16–17, 75–79	Speed limits	
· Deep groove ball bearings	20	Direct oil lubrication	16–17, 77–78	Precision nuts	84	Speed correction factors	
· Spindle ball bearings	50	Direct oil lubrication bearing versions	16–17, 77–78	Preload		· Spindle ball bearings	80
Bearing frequencies	92	· +A		· Spring	61	· Deep groove ball bearings	81
Bearing lubrication	72–79	· +AB		· Rigid	62–63	Spindle ball bearing series	6–7, 14–19
Bearing sets	65	· +L		Processing tolerances	71	· S	
Bearing selection	57–59	· +LB		Quality management	98	· SM	
Bearing storage	82	Fits	70–71	Rigidity	60	· KH	
Boundary dimensions	9	Fixed bearings	61			· BHT	
Clamping force	85	Floating bearing	61			· BNT	
Clearance	49	Grease distribution run	83			Spindle ball bearing cages	10–11
· Deep groove ball bearings		Grease fill quantities	73			· TA	
Consultation	93	Grease lubrication	72–75			· TXM	
Contact angle	67	Grease re-lubrication	18, 74			Static load capacity	91
		Greased bearings	73			Tightening torque	85
						Training courses	93



Internet

At our Internet site www.gmn.de we provide comprehensive product information that can be downloaded.

GMN

GMN Paul Müller Industrie GmbH & Co. KG manufactures high precision ball bearings, machine spindles, freewheel clutches and seals for a broad spectrum of applications at its Nuremberg, Germany plant.

On the basis of long experience in the development and production of machine components, GMN has specialized in the manufacture of high quality products in the field of high precision ball bearings and, beyond a comprehensive standard product line, also offers customer-oriented special solutions.

A global GMN service network offers competent customer consultation and individualized solutions.

GMN Quality management – tested and certified.

GMN guarantees utmost quality for its products and services that is based on long-term reliability. Highly modern development and production methods ensure products that always represent state-of-the-art technology. All GMN corporate divisions are structured for transparency and clear organizational workflows to ensure customer-oriented services and economic security.

All GMN corporate divisions are certified to DIN ISO 9001:2008 .



GMN – safeguarding the future.

For GMN, progress means the best possible customer support combined with performance-oriented optimization of its technical products.

This claim is realized at GMN under especially strict observance of national and international environmental standards with regard to efficient, responsible utilization of ecological resources.



GMN

- High precision ball bearings
- Spindle technology
- Freewheel clutches
- Non-contact seals