









Linear Systems

Page

Overview, Examples of Use, Advantages/Characteristics			66 – 77	
Franke Dynamic				
Type FDA	Standard		78 – 79	
Type FDB	Low cost		80 – 81	
Type FDC	Non-corrosive		82 – 83	
Type FDD	Non-magnetic		84 – 85	
Type FDE	Lubricant-free		86 – 87	
Type FDG	Non-corrosive low cost		88 – 89	
Type FDH	High dynamic		90 – 91	
Franke Power				
Type FPA	Standard		92 – 93	
Franke Robust				
Type FRA	Standard		94 – 95	
Linear Tables/Modules				
FTB	Spindle Drive		96 – 97	
FTC	Spindle/Belt Drive		98 – 99	
FTD	Belt Drive		100 – 101	
FTH	Linear Motor Drive		102 – 105	
Accessories				
Guides			106 – 107	
Modules			108 – 109	
Technical Information				
Franke Dynamic			110 – 112	
Franke Power			113 – 114	
Franke Robust			115 – 116	
Linear Tables/Modules			117 – 119	

Linear Systems at a Glance

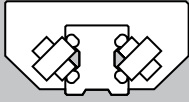
Roller Guide Franke Dynamic						
Type	FDA Standard	FDB Low cost	FDC Non-corrosive	FDD Non-magnetic	FDE Lubricant-free	
Components	<ul style="list-style-type: none"> Steel raceways Needle bearing rollers 	<ul style="list-style-type: none"> Steel raceways Ball bearing rollers 	<ul style="list-style-type: none"> Non-corrosive raceways Needle bearing non-corrosive rollers 	<ul style="list-style-type: none"> Non-magnetic raceways Needle bearing rollers 	<ul style="list-style-type: none"> Steel raceways Lubricant-free rollers 	
Options	<ul style="list-style-type: none"> Special guide profiles Surface coating of the raceways and cassettes Customer-specific connection borings Metal wipers Bellow covers Extended cassettes and roller shoes for higher loads Connections for central lubrication Individual design of the cassettes (e.g. with spindle acceptance or connection of measuring systems) High-load raceways for use with linear motors 					
Advantages	<ul style="list-style-type: none"> Easier and quieter running thanks to large-size rollers Fast response behaviour No stick-slip effect Slide resistance can be adjusted up and down Aluminium body materials harmonise perfectly with aluminium carrier profiles and facilitate design of lighter constructions 					
Use	<ul style="list-style-type: none"> For high loads in all applications 	<ul style="list-style-type: none"> For low loads in all applications 	<ul style="list-style-type: none"> For medium loads in moist or aggressive environment 	<ul style="list-style-type: none"> For light loads in magnetic fields or radiation rooms 	<ul style="list-style-type: none"> For medium loads under extremely hygienic conditions 	
Sizes (mm)	12 – 45	12 – 45	15 – 45	25	12 – 45	
Travelling speed	<ul style="list-style-type: none"> Sizes and special shapes for series production at customer's request 					
Rail length (mm)	4000	4000	4000	4000	4000	
More on page	78 – 79	80 – 81	82 – 83	84 – 85	86 – 87	

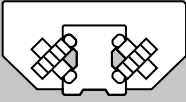
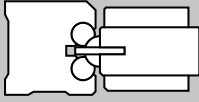
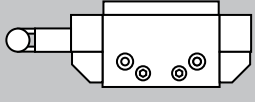
		Recirculating Rollers Franke Power	Recirculating Ball Guide Franke Robust	Systems
FDG Non-corrosive low cost	FDH High dynamic	FPA Standard 	FRA Standard 	FTB, FTC, FTD, FTH  NEW
<ul style="list-style-type: none"> Non-corrosive raceways Ball bearing non-corrosive rollers 	<ul style="list-style-type: none"> Steel raceways 2-row bearing rollers 	<ul style="list-style-type: none"> Aluminium body material Steel raceways 2 rows of recirculating rollers, arranged at 90° angles Plastic wiper Lubricating nipple 	<ul style="list-style-type: none"> Aluminium body material Steel raceways 1 row of recirculating balls, balls with dividers Felt wiper 	<ul style="list-style-type: none"> Linear tables/modules with spindle, belt or linear motor drive, motors, CNC controls Integrated Franke Linear Systems
		<ul style="list-style-type: none"> Slide resistance set ex works Cassette prefitted on raceway 	<ul style="list-style-type: none"> Non-corrosive or non-magnetic raceways Bore shape to specifications 	<ul style="list-style-type: none"> Complete multi-axe systems Mounting angle Measuring systems Special sizing and bore shapes available for series production Niro version
<ul style="list-style-type: none"> Corrosion-resistant Reasonable price 	<ul style="list-style-type: none"> Fast response behaviour 	<ul style="list-style-type: none"> High stiffness High load capacity High moment load rating All-round sealing Relubrication possible via funnel-type lubricating nipple Lubrication connection possible on 4 sides 	<ul style="list-style-type: none"> High load rating High lifetime Robust also under severe conditions Shock and impact-resistant High stiffness 	<ul style="list-style-type: none"> Free choice of motorisation Highest dynamic Compact dimensions Linear motor module with wear-free drive
<ul style="list-style-type: none"> For low loads in moist or aggressive environment 	<ul style="list-style-type: none"> For high loads and high accelerations 	<ul style="list-style-type: none"> For high loads and moment loading in heavy load operation 	<ul style="list-style-type: none"> For applications with the highest loads in harsh environments 	<ul style="list-style-type: none"> For automation, measuring and testing applications, recirculating, processing, mounting
12 – 45	25 – 45	25	06 – 13	15 – 35
10 40	10 40	3 40	3 30	10 100
4000	4000	4000 continuously coupled	4000 continuously coupled	7000 –
88 – 89	90 – 91	92 – 93	94 – 95	96 – 105

Linear Systems in Practice

The Franke principle of the guided roller guarantees easy and silent running, even at high speeds. These factors are essential for smooth production in many industries. Therefore, Franke Linear Systems are also used in the most diverse industrial sectors – for example in medical technology, the food industry, for machine and plant engineering or in the handling sector.

In Medical Technology: Dental X-Ray Equipment



Precise x-rays need the movement of the light unit to be completely vibration-free. Therefore, the roller guide used must have smooth and silent running. The Franke Dynamic Aluminium Roller Guide fulfils this demand perfectly.

The Features:

- The Franke Dynamic Aluminium Roller Guide has lifetime lubrication.
- Sealed rollers prevent the lubricant escaping.
- The guide's running is silent, smooth and even.
- Preloading the cassette ensures vibration-free movement of the secondary light.

In the Packing Industry: Bakery Machinery



A fast, clean and maintenance-free linear system is required in a packing machine for baking mixes. Two retractable axles must be able to run simultaneously on the longitudinal module. The high dynamic of the guide results in correspondingly high cycle times when packing.

The Features:

- The system of embedded raceways facilitates the use of light-weight, extruded aluminium profiles for the guide rails, the magnets of the stator are directly integrated; the motor rests in an aluminum housing.
- The direct drive facilitates fast positioning that is free from clearance.
- The guide achieves movement speeds of 6 m/s and acceleration of up to 100 m/s².
- Sealed rollers prevent the lubricant escaping.

In the Food Industry: Cheese Production



In cheese production the food-safe Franke Dynamic Aluminium Roller Guide provides the vertical movement of a gripper for wheels of cheese. In this application it is important that the roller guide is insensitive to whey and aggressive cleaning agents.

The Features:

- The guide is insensitive to moisture.
- Its running is easy and silent, the drive power is low.
- No maintenance and lubrication for the whole lifetime are guaranteed.
- An integrated wiper fulfils the specific hygiene requirements for food production.
- The product is available in a lubricant-free version on request.

In the Packing Industry: Bag Former/Filler

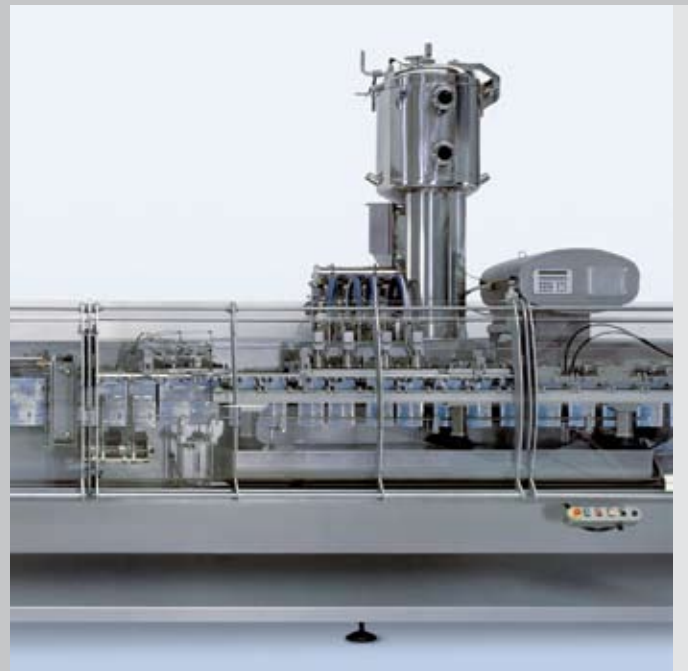

A bag forming, filling and sealing machine works at high speeds. It has stroke lengths of 1500 to 2100 mm, the average service performance is 30000 kilometers a year. The Franke Dynamic Aluminium Roller Guide used must be resistant to the aggressive environmental conditions, such as salt, sugar and splash water.

The Features:

- The Franke Dynamic Aluminium Roller Guide is in a position to realise speeds up to 10 m/s.
- Several guides can be coupled for any length of stroke desired.
- A good lifetime and service performance are achieved through central lubrication of the cassette.

Linear Systems in Practice

In Plant Engineering: Packaging Machines



The Franke Dynamic Aluminium Roller Guide is also used on packaging machinery for mattresses. In addition to cleanliness, the mobile function of the guide unit must be ensured, to avoid soiling the mattresses.

The Features:

- The Franke Dynamic Aluminium Roller Guide is maintenance-free and requires no relubrication.
- No lubricant can escape from the encapsulated rollers.
- The guide is available in a completely lubricant-free design on request.

In the Handling Sector: High Speed Camera Guiding



The Franke Dynamic Aluminium Roller Guide moves the high speed camera for a film printing machine. A results check is performed during the printing process by camera or video. As films of different widths are printed, the camera must be easy to position.

The Features:

- The Franke Dynamic Aluminium Roller Guide has smooth, even running.
- It weighs very little as the body material of the rail is aluminium.
- Special borings guarantee connection to the path measuring system.

In Machinery: Ring and Drum Coilers



The Franke Power Aluminium Recirculating Roller Guide is used for machines that process and pack coiled goods. It ensures that cables, hoses or steel ropes are coiled on rings or empty spools, measured to length and cut.

The Features:

- The Franke Power Aluminium Roller Guide has high load-capacity and stiffness.
- The cassettes are completely sealed and are also suitable for harsh conditions.
- Integrated metal wipers keep the raceways clean.

In Machinery: Handling System



Different processing centres are coupled together in this machine through large portals. Workpieces are processed with high acceleration. The Franke Robust Aluminium Recirculating Ball Guide is used in the transfer line. The recirculating ball system of type FRA10 and FRA13 harmonises perfectly with the substructure of aluminium profiles.

The Features:

- Transfer speeds of up to 3 m/s and accelerations of up to 30 m/s² are achieved.
- The Franke Robust Aluminium Recirculating Ball Guides used have a high lifetime, even in harsh and very dirty conditions.
- Tolerances and unevenness in the substructure can be equalised to a certain extent.

Franke Dynamic

Aluminium Roller Guide – Advantages and Characteristics

Type FDA – FDH

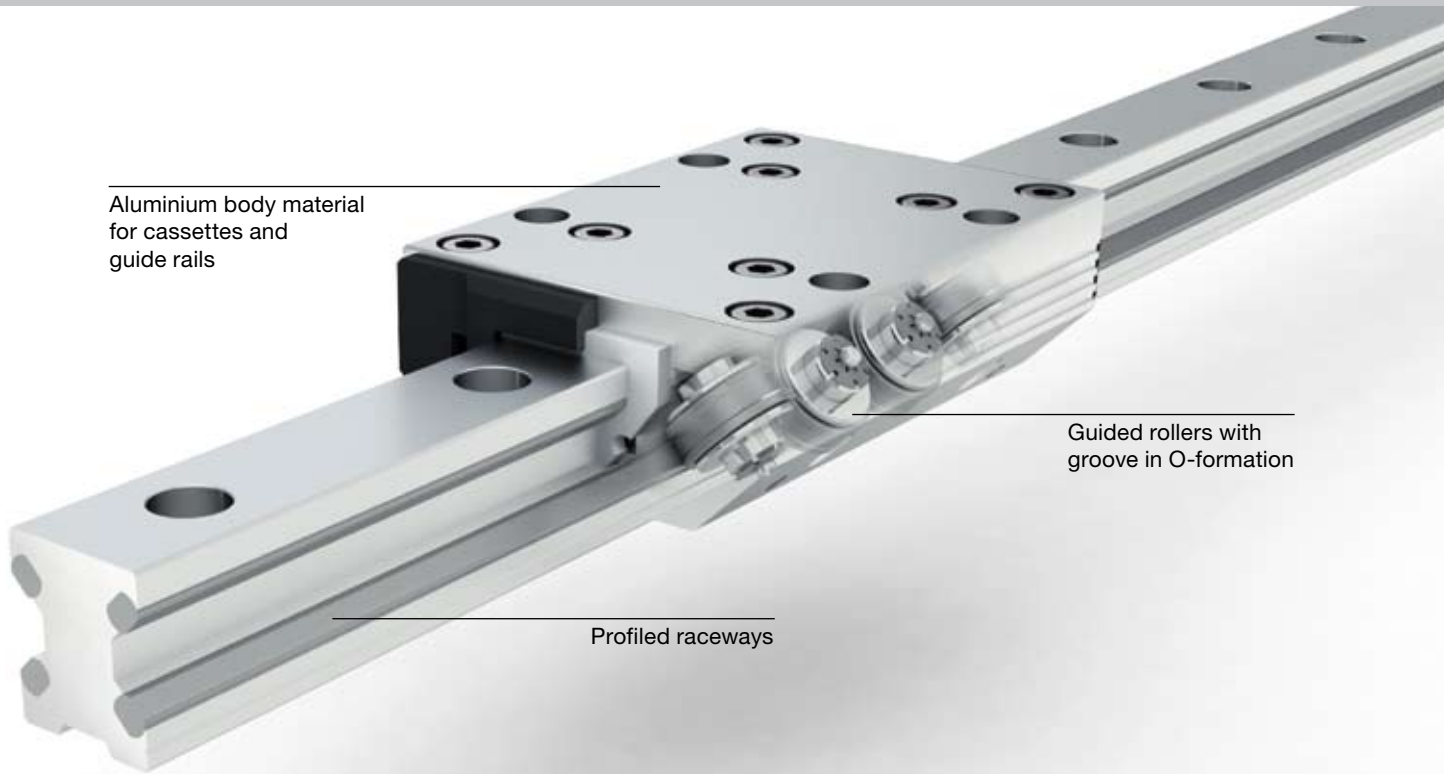

Aluminium body material
for cassettes and
guide rails

Guided rollers with
groove in O-formation

Profiled raceways



The Characteristics:

Cassettes and Roller Shoes

The cassette of the Franke Dynamic Aluminium Roller Guide has aluminium body material with needle or ball bearing rollers of steel or stainless steel. Special cover discs on the roller seal the bearing to the outside.

Eight rollers in O-formation guarantee an equally high load capacity from all directions. The rollers are equipped with a groove, which is adjusted to the profile of the raceway. Thanks to this patented system of guided rollers, the rollers are guided laterally and equally smooth and silent running is guaranteed.

The cassette plate has mounting holes in accordance with international standards. The slide resistance can be adjusted up and down individually using a setting screw on the side. Five standard sizes are available from size 12 to 45.

In the pair of single rails with roller shoes version there is no cassette plate. As a result, the guide width can be selected freely. The roller shoes are screwed directly to the mating structure and facilitate extremely compact assemblies.

Thread pieces for one-sided adjustability of the slide resistance are supplied and can be integrated.

The Advantages:

- Low weight thanks to aluminium body material
- Silent and easy running thanks to the patented **Guided Roller®**
- Maintenance-free and clean
- O-formation for equal loads from all directions
- High traverse speed and acceleration
- Numerous variations for almost any application
- Customer-specific solutions if series needed



Wipers

The bearings of the rollers are sealed and have lifetime lubrication. Thanks to the standard felt wiper, lasting protection of the guide system from soiling is guaranteed.

Metal wipers are included as accessories, which are particularly recommended for coarse dirt such as chippings or sawdust and keep the raceway clean (see accessories page 106).

Lubricant-free cassettes and roller shoes are available as type FDE. They are also suitable for hygienically sensitive sectors, for example the food industry or medical technology.

Guide Rails

The raceways of spring steel, non-corrosive or non-magnetic steel are integrated in the aluminium profile. The O-formation guarantees high load capacity from all directions. The profile of the rollers is adjusted to the raceway and guarantees permanently precise and smooth running.

The guide rails are available in one piece up to a length of four meters. They can be continuously coupled for longer strokes. we can supply rail profiles specially tailored to your design on request.

Franke precision raceways of spring steel, non-corrosive or non-magnetic steel can be integrated into a variety of aluminium profiles. We can supply your chosen profile complete with integrated raceways in series production.

We also offer specially hardened raceways for the heaviest loads.

Franke Dynamic

Aluminium Roller Guide – Numerous Possibilities

The Different Types:

Type FDA	Standard
Type FDB	Low cost
Type FDC	Non-corrosive
Type FDD	Non-magnetic
Type FDE	Lubricant-free
Type FDG	Non-corrosive low cost
Type FDH	High dynamic

We can also supply special cassettes in specific dimensions, heat-resistant versions and vacuum-fit for series production. Please call us.

Further Possibilities:

Design

For series production it is possible to adjust the shape and design of the cassettes, roller shoes and guide profiles to your individual application. You will get the perfect solution tailored to your requirements.

Adjustment options are:

- Shortened or extended roller shoes/cassettes
- Special shapes, e.g. for integration of drives
- Special profiles of guide rails according to your needs
- Individual bore shapes on the guide rails
- Fixing from underneath

Vacuum/High Temperature

We also offer special cassettes and roller shoes for applications in vacuums. They are designed with free borings and equipped with lubricants suited to high vacuums on request.

You can choose from a selection of special, heat-resistant cassettes and roller shoes for applications with radiant heat in the vicinity of heat sources.

Temperature ranges up to 200 °C are possible.





Complete Systems

The Franke Dynamic Aluminium Roller Guides are also used in our complete systems of linear axis, drive, motorisation and control. Franke Linear Modules and Linear Tables use the assets of Linear Systems to build-up complete moving units.

Toothed belt gear Linear Modules are available up to a stroke length of 7000 mm. The integrated Franke Dynamic Aluminium Roller Guide provides high dynamic movements and easy and silent running.

Clean Room

The Franke Dynamic Aluminium Roller Guide was appraised and evaluated at the Institut für Produktionstechnik und Automatisierung (IPA) at the Fraunhofer Gesellschaft (FhG) in Stuttgart with regard to its operation in rooms with high air purity rates.

It is extremely suitable for the listed loading conditions. The trends of the results (e.g. particle emissions on increase of the moved mass) allow us to state that a suitability for "Class 1000" is also achieved for higher loads.

The result: the Franke Dynamic Aluminium Roller Guide of type FDA is suitable for clean room-typical movement speeds for use in clean rooms with air purity classes "Class 1000".



Franke Power

Aluminium Recirculating Roller Guide

Type FPA

The Advantages:

- High load capacity and stiffness
- Connecting dimensions compatible with international standards
- Integrated metal wipers
- All-round sealing

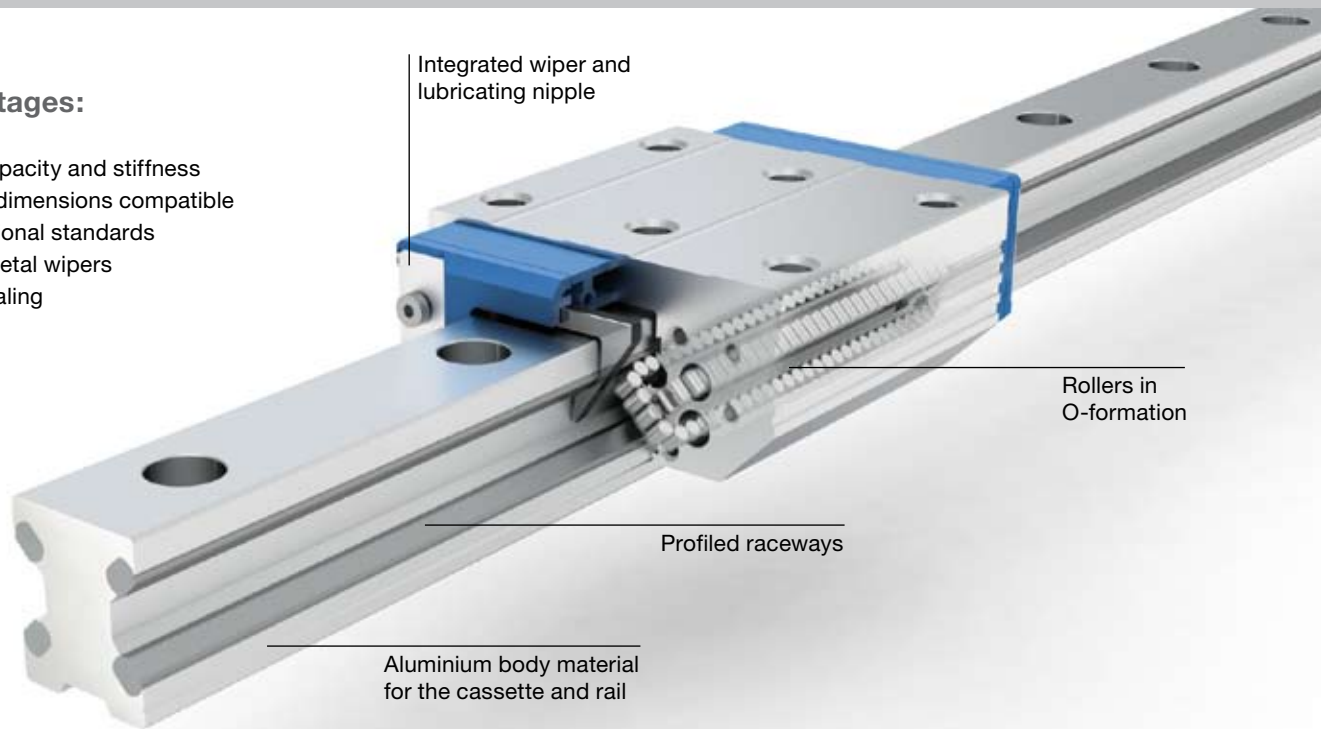

The Characteristics:

Cassette

The cassette of the Franke Power Aluminium Recirculating Roller Guide is made from special aluminium with fixing bores in accordance with international standards and, therefore, is interchangeable with products from many manufacturers. Wear-resistant plastic seals provide all-round sealing for the cassette. The additional frontal metal wipers are adjusted to the rail contour and protect the guide system from coarse impurities.

The recirculating rollers in 90°-formation guarantee even, high load capacity and loading from every direction. Each cassette has a lubrication nipple, which can be attached to one of the four front ends. A defined slide resistance ensures alignment on the guide rails. It is supplied with a preload class with light preload. The guides can be mounted on unprocessed surfaces without impairing the lifetime. The inner elasticity of the Recirculating Roller Guide is ensured by a system patented by Franke.

Guide Rails

Raceways of spring steel, non-corrosive or non-magnetic steel are integrated in the aluminium profile. High load capacity from all directions is guaranteed by the O-formation. The profile of the rollers is adjusted to the raceway and ensures precise and easy running permanently.

The guide rails can be supplied as one piece up to a length of four meters and can be coupled together endlessly for longer strokes. We can supply bore shapes specially tailored to your design on request.

FTH Drive

Aluminium Linear Motor Module

Type FTH



The Advantages:

- Low space requirement (height)
- Greater closeness of the system (no double-track rail set-up), so simpler to clean and less risk of contamination
- Reduced components

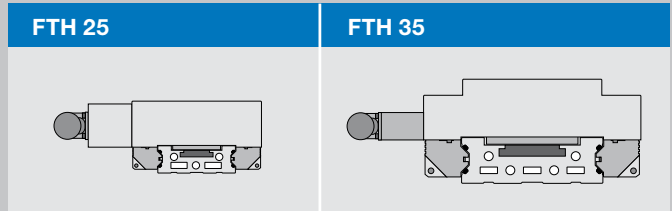
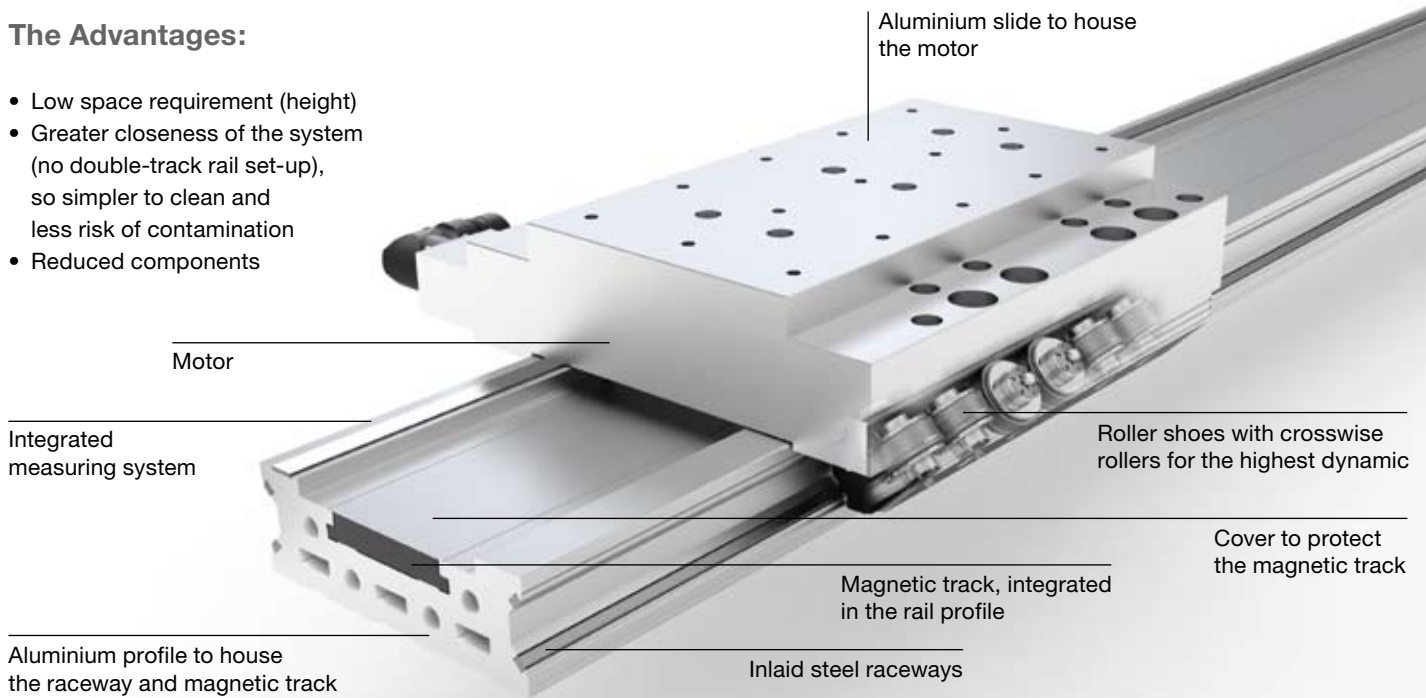

The Characteristics:

Roller Shoes and Guide Rails

Building on the proven Franke Aluminium Roller Guide, the Linear Motor Module FTH impresses with its low weight and compact dimensions. The roller shoes have been specially designed for high loads. The rail profile was designed so that the stator could be integrated. This saves height and weight. The modular design of the system enables numerous adjustments according to the individual use.

Multi-Module Systems

In addition to customer-specific mating and profile dimensions, several slides can be moved independently of one another per module. Complete multi-module systems using angles and adapter plates is also possible. We can supply the Linear Motor Module with all wiring and tailored to your desired control mode on request.

The Franke FTH Drive in comparison to conventional products

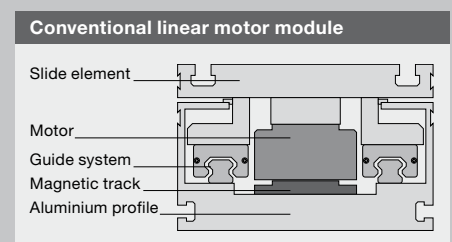
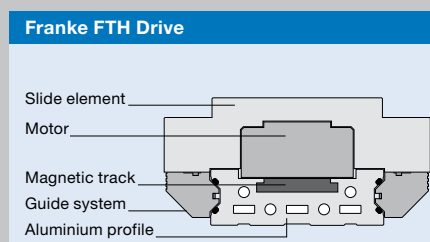

Cassette + double rail

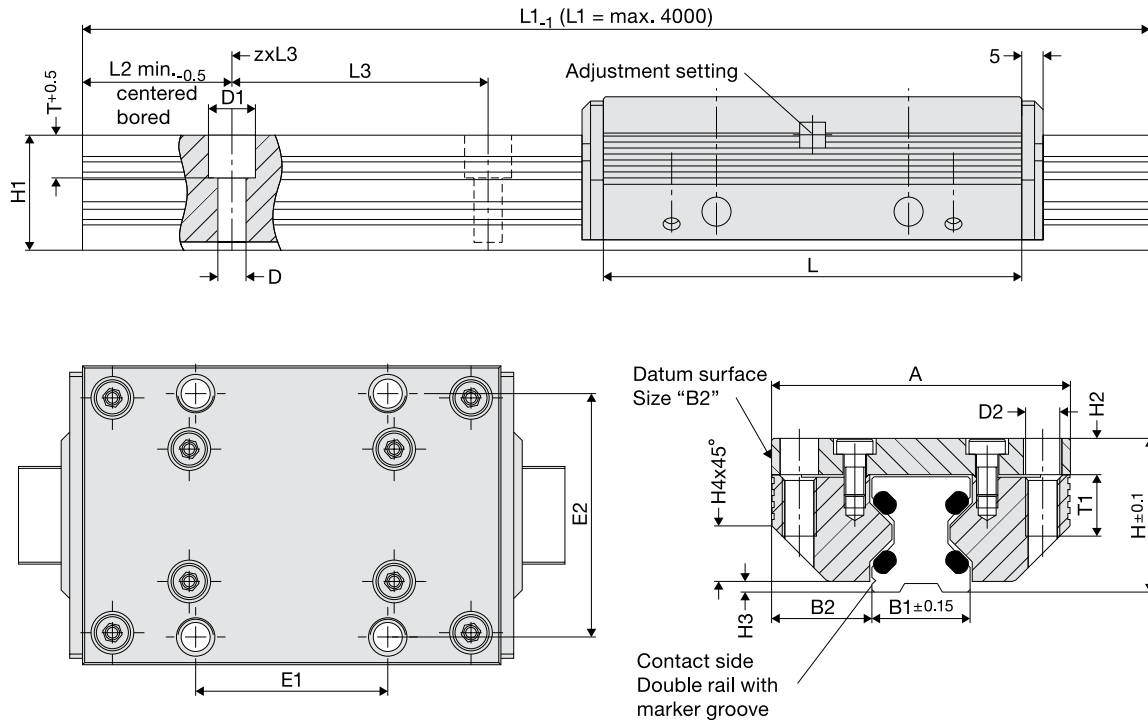

Dimensions

Size	Dimensions																	
	A	L	H	B1	B2	D	D1	D2	E1	E2	H1	H2	H3	H4	L2	L3	T	T1
12	37	64	19	12.0	12.50	3.4	6	M 4	25	30	14.7	4.0	1.4	5.5	10	40	5.5	8
15	47	78	24	15.5	15.75	4.5	8	M 5	30	38	18.7	5.0	2.0	8.0	10	60	6.0	10
20	63	92	30	21.0	21.00	5.5	10	M 6	40	53	22.6	7.0	2.0	11.0	10	60	8.0	12
25	70	98	36	23.0	23.50	6.6	11	M 8	45	57	27.0	8.5	2.5	13.0	10	60	10.0	16
35	100	135	48	32.0	34.00	9.0	15	M10	62	82	37.0	10.5	3.5	20.0	12	80	11.5	20
45	120	165	60	45.0	37.50	11.0	18	M12	80	100	46.0	13.5	4.0	22.0	16	105	14.5	24

Load ratings, weight

Size	Load ratings		Moment load ratings* cassette				Weight	
	N	Co	Mocx	Mcx	Mocy/Mocz	Mcy/Mcz	Cassette	kg rail/m
12	2800	3000	27	25	43	40	0.1	0.4
15	4200	3400	37	45	58	72	0.2	0.8
20	5400	5400	76	76	111	111	0.4	0.9
25	9000	10100	158	142	222	198	0.5	1.8
35	12500	18000	423	294	559	388	1.4	3.2
45	21200	25900	827	678	983	806	2.5	5.5

Order numbers

Order no.	Order key
Cassette	Double rail
84494A	e.g. FDA25D1500
84396A	
84441A	
84363A	
84364A	
84365A	Size

*There is more information on moment load ratings on page 110/111.

**Guide rails up to 4000 mm on one piece. Longer strokes are coupled.

Materials

	Body material	Rollers	Wipers
Standard	High-strength, anodized aluminium	Antifriction bearing steel	Plastic plate with felt wiper

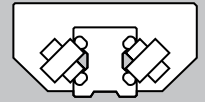

Pair of roller shoes + single rail pairs

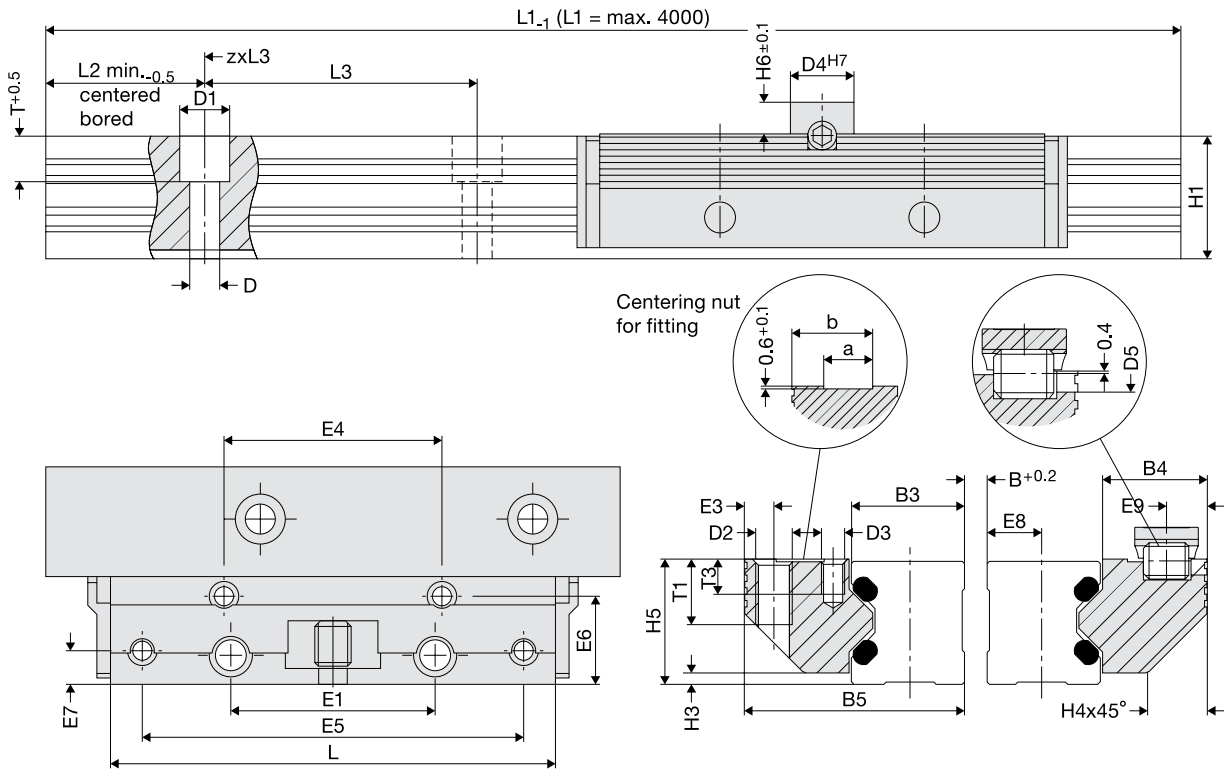

Dimensions

Size	Dimensions																	
	B5	H5	B3	B4	D3	D4	D5	E3	E4	E5	E6	E7	E8	E9	H6	T3	a	b
12	24.4	15.0	12.00	11.9	M3	8	3	3.4	29	57	9.7	3.4	5.5	4.9	4	6.0	4.5	9.5
15	30.9	19.0	15.25	15.2	M4	10	4	4.4	34	68	12.4	4.9	7.0	5.9	5	7.5	5.0	12.5
20	40.9	23.0	20.00	20.4	M5	10	4	4.9	42	80	16.9	5.9	9.5	5.9	5	8.0	7.5	16.0
25	48.4	27.5	25.00	22.9	M5	14	6	6.4	48	84	19.4	7.4	12.0	8.9	7	5.0	10.5	17.5
35	68.9	37.5	35.00	32.9	M6	14	6	8.9	67	117	28.4	8.9	17.0	8.9	7	7.5	12.5	26.0
45	82.4	46.5	45.00	36.4	M8	14	6	9.9	83	146	30.9	9.9	22.0	8.9	7	9.5	15.5	31.0

Load ratings, weight

Size	Load ratings		Moment load ratings* RSP				Weight	
	N	Co	Nm		RSP		kg	
	C	Co	Mocx	Mcx	Mocy/Mocz	Mcy/Mcz	RSP	rail/m
12	2800	3000	1.5(B+ 30.3)	1.4(B+ 30.3)	43	40	0.07	0.4
15	4200	3400	1.7(B+ 36.5)	2.1(B+ 36.5)	58	72	0.12	0.8
20	5400	5400	2.7(B+ 47.0)	2.7(B+ 47.0)	111	111	0.23	1.0
25	9000	10100	5.0(B+ 58.4)	4.5(B+ 58.4)	222	198	0.34	1.9
35	12500	18000	9.0(B+ 85.0)	6.3(B+ 85.0)	559	388	0.99	3.5
45	21200	25900	12.9(B+109.0)	10.6(B+109.0)	983	806	1.79	5.6

*There is more information on moment load ratings on page 110/111.

Order numbers

Order no.	Order key
RSP	Single rail pair
84495A	e.g. FDA25E1500
84395A	
84442A	
84367A	
84368A	
84369A	Size

**Guide rails up to 4000 mm on one piece. Longer strokes are coupled.

Cassette + double rail

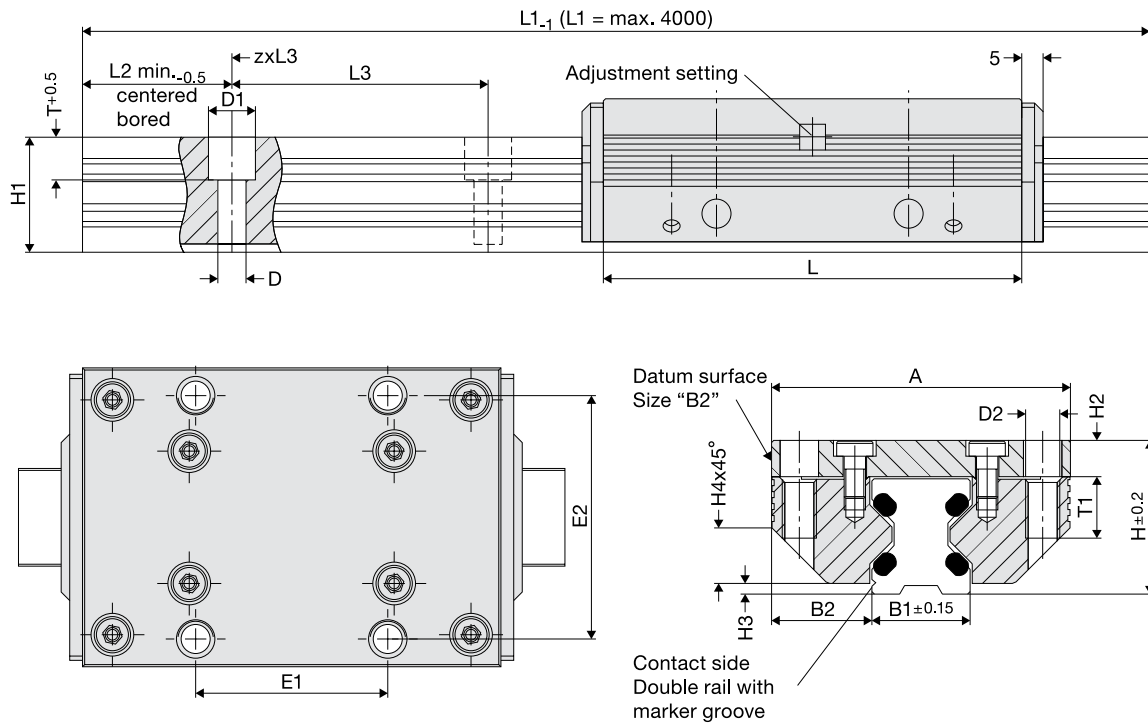

Dimensions

Size	Dimensions																	
	A	L	H	B1	B2	D	D1	D2	E1	E2	H1	H2	H3	H4	L2	L3	T	T1
12	37	64	19	12.0	12.50	3.4	6	M 4	25	30	14.7	4.0	1.4	5.5	10	40	5.5	8
15	47	78	24	15.5	15.75	4.5	8	M 5	30	38	18.7	5.0	2.0	8.0	10	60	6.0	10
20	63	92	30	21.0	21.00	5.5	10	M 6	40	53	22.6	7.0	2.0	11.0	10	60	8.0	12
25	70	98	36	23.0	23.50	6.6	11	M 8	45	57	27.0	8.5	2.5	13.0	10	60	10.0	16
35	100	135	48	32.0	34.00	9.0	15	M10	62	82	37.0	10.5	3.5	20.0	12	80	11.5	20
45	120	165	60	45.0	37.50	11.0	18	M12	80	100	46.0	13.5	4.0	22.0	16	105	14.5	24

Load ratings, weight

Size	Load ratings		Moment load ratings* cassette				Weight	
	C	Co	Mocx	Mcx	Mocy/Mocz	Mcy/Mcz	Cassette	rail/m
12	620	170	1.6	5.7	2.4	8.9	0.1	0.4
15	700	230	2.5	7.5	4.0	12.0	0.2	0.8
20	940	300	4.0	13.0	6.0	19.0	0.4	0.9
25	1500	700	11.0	23.0	15.0	32.0	0.5	1.8
35	3100	1400	32.0	72.0	42.0	95.0	1.4	3.2
45	6300	2700	86.0	200.0	103.0	238.0	2.5	5.5

Order numbers

Order no.	Order key
Cassette	Double rail
84494L	e.g. FDA25D1500
84396L	
84441L	
84363L	
84364L	
84365L	

*There is more information on moment load ratings on page 110/111.

**Guide rails up to 4000 mm on one piece. Longer strokes are coupled.

Materials

	Body material	Rollers	Wipers
Standard	High-strength, anodized aluminium	Antifriction bearing steel	Plastic plate with felt wiper

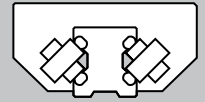

Pair of roller shoes + single rail pairs

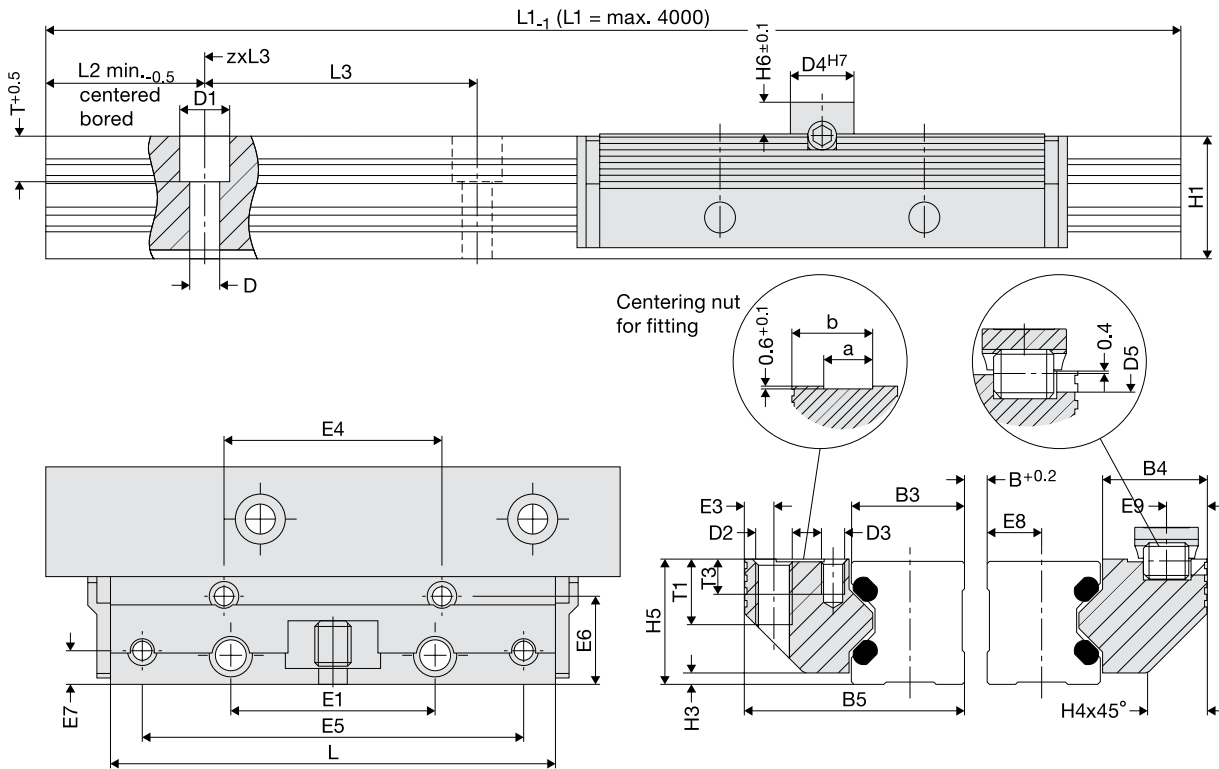

Dimensions

Size	Dimensions																		
	B5	H5	B3	B4	D3	D4	D5	E3	E4	E5	E6	E7	E8	E9	H6	T3	a	b	
12	24.4	15.0	12.00	11.9	M3	8	3	3.4	29	57	9.7	3.4	5.5	4.9	4	6.0	4.5	9.5	
15	30.9	19.0	15.25	15.2	M4	10	4	4.4	34	68	12.4	4.9	7.0	5.9	5	7.5	5.0	12.5	
20	40.9	23.0	20.00	20.4	M5	10	4	4.9	42	80	16.9	5.9	9.5	5.9	5	8.0	7.5	16.0	
25	48.4	27.5	25.00	22.9	M5	14	6	6.4	48	84	19.4	7.4	12.0	8.9	7	5.0	10.5	17.5	
35	68.9	37.5	35.00	32.9	M6	14	6	8.9	67	117	28.4	8.9	17.0	8.9	7	7.5	12.5	26.0	
45	82.4	46.5	45.00	36.4	M8	14	6	9.9	83	146	30.9	9.9	22.0	8.9	7	9.5	15.5	31.0	

Load ratings, weight

Size	Load ratings		Moment load ratings* RSP				Weight		
	N	Co	Nm		RSP		kg		
	C	Co	Mocx	Mcx	Mocy/Mocz	Mcy/Mcz	RSP	rail/m	
12	620	170	0.08(B+ 30.3)	0.30(B+ 30.3)		2.4	8.9	0.07	0.4
15	700	230	0.10(B+ 36.5)	0.35(B+ 36.5)		4.0	12.0	0.12	0.8
20	940	300	0.15(B+ 47.0)	0.50(B+ 47.0)		6.0	19.0	0.23	1.0
25	1500	700	0.35(B+ 58.4)	0.70(B+ 58.4)		15.0	32.0	0.34	1.9
35	3100	1400	0.70(B+ 85.0)	1.50(B+ 85.0)		42.0	95.0	0.99	3.5
45	6300	2700	1.40(B+109.0)	3.10(B+109.0)		103.0	238.0	1.79	5.6

*There is more information on moment load ratings on page 110/111.

Order numbers

Order no.	Order key
RSP	Single rail pair

e.g. **FDA25E1500**

**Guide rails up to 4000 mm on one piece. Longer strokes are coupled.

Cassette + double rail

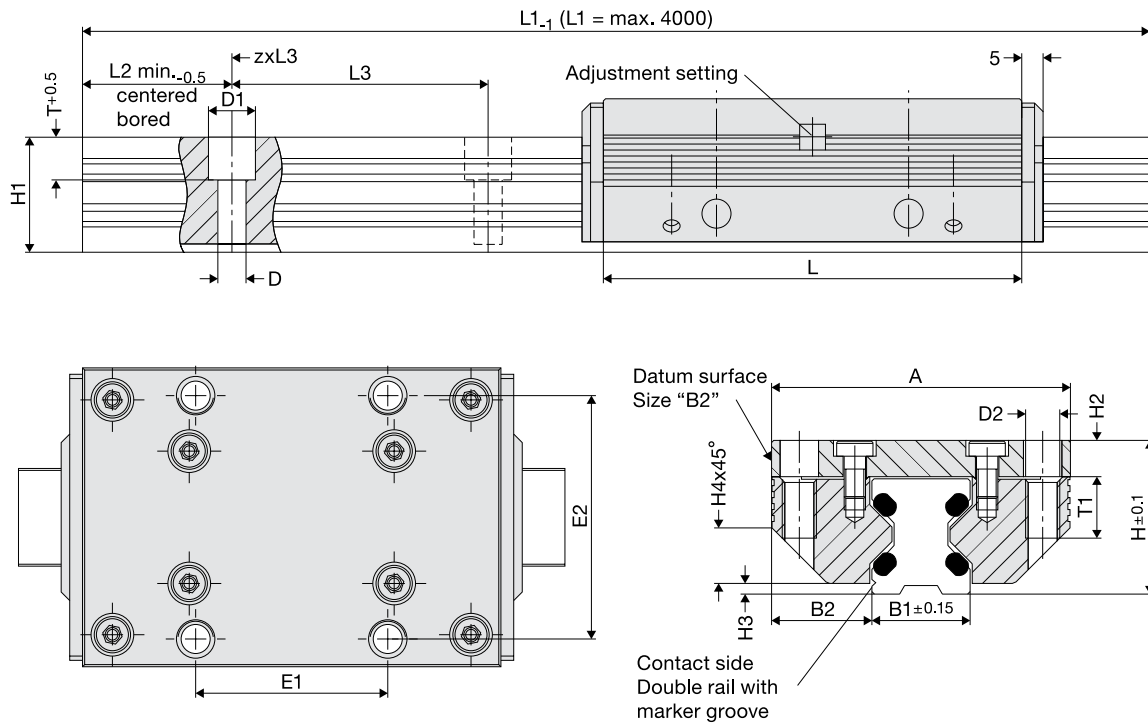

Dimensions

Size	Dimensions																	
	A	L	H	B1	B2	D	D1	D2	E1	E2	H1	H2	H3	H4	L2	L3	T	T1
12	37	64	19	12.0	12.50	3.4	6	M 4	25	30	14.7	4.0	1.4	5.5	10	40	5.5	8
15	47	78	24	15.5	15.75	4.5	8	M 5	30	38	18.7	5.0	2.0	8.0	10	60	6.0	10
20	63	92	30	21.0	21.00	5.5	10	M 6	40	53	22.6	7.0	2.0	11.0	10	60	8.0	12
25	70	98	36	23.0	23.50	6.6	11	M 8	45	57	27.0	8.5	2.5	13.0	10	60	10.0	16
35	100	135	48	32.0	34.00	9.0	15	M10	62	82	37.0	10.5	3.5	20.0	12	80	11.5	20
45	120	165	60	45.0	37.50	11.0	18	M12	80	100	46.0	13.5	4.0	22.0	16	105	14.5	24

Load ratings, weight

Size	Load ratings		Moment load ratings* cassette				Weight	
	N	Co	Nm				Cassette	kg
	C	Co	Mocx	Mcx	Mocy/Mocz	Mcy/Mcz	Cassette	rail/m
12	1100	1200	11	10	17	16	0.1	0.4
15	2700	3000	33	29	52	46	0.2	0.8
20	4300	5000	71	61	103	89	0.4	0.9
25	5800	8300	132	92	184	128	0.5	1.8
35	10000	14500	343	237	452	312	1.4	3.2
45	17000	20400	651	542	774	645	2.5	5.5

Order numbers

Order no.	Order key
Cassette	Double rail
84494AN	e.g. FDC25D1500
84396AN	
84441AN	
84363AN	
84364AN	
84365AN	Size

*There is more information on moment load ratings on page 110/111.

**Guide rails up to 4000 mm on one piece. Longer strokes are coupled.

Materials

	Body material	Rollers	Wipers
Standard	High-strength, anodized aluminium	Antifriction bearing steel	Plastic plate with felt wiper

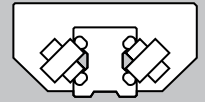

Pair of roller shoes + single rail pairs

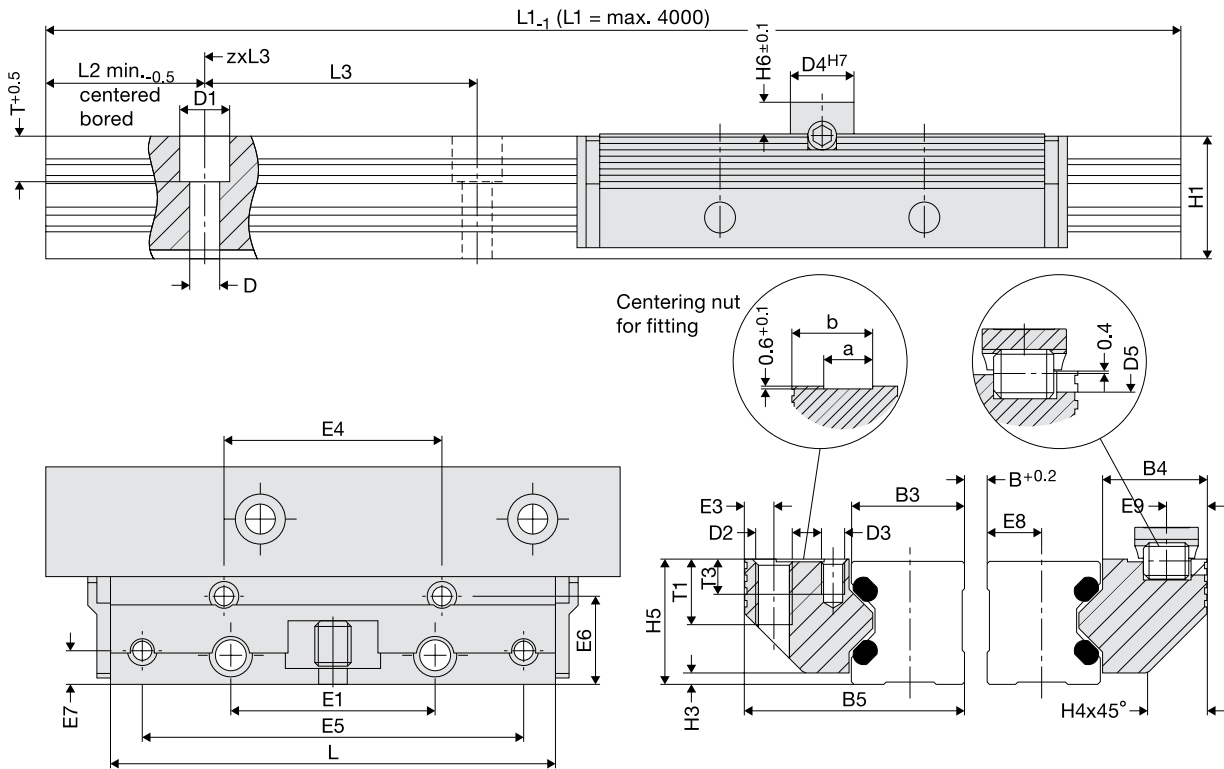

Dimensions

Size	Dimensions																		
	B5	H5	B3	B4	D3	D4	D5	E3	E4	E5	E6	E7	E8	E9	H6	T3	a	b	
12	24.4	15.0	12.00	11.9	M3	8	3	3.4	29	57	9.7	3.4	5.5	4.9	4	6.0	4.5	9.5	
15	30.9	19.0	15.25	15.2	M4	10	4	4.4	34	68	12.4	4.9	7.0	5.9	5	7.5	5.0	12.5	
20	40.9	23.0	20.00	20.4	M5	10	4	4.9	42	80	16.9	5.9	9.5	5.9	5	8.0	7.5	16.0	
25	48.4	27.5	25.00	22.9	M5	14	6	6.4	48	84	19.4	7.4	12.0	8.9	7	5.0	10.5	17.5	
35	68.9	37.5	35.00	32.9	M6	14	6	8.9	67	117	28.4	8.9	17.0	8.9	7	7.5	12.5	26.0	
45	82.4	46.5	45.00	36.4	M8	14	6	9.9	83	146	30.9	9.9	22.0	8.9	7	9.5	15.5	31.0	

Load ratings, weight

Size	Load ratings		Moment load ratings* RSP				Weight	
	N	Co	Nm		Nm		RSP	kg
	C	Co	Mocx	Mcx	Mocy/Mocz	Mcy/Mcz	RSP	rail/m
12	1100	1200	0.6(B+ 30.3)	0.6(B+ 30.3)	17	16	0.07	0.4
15	2700	3000	1.5(B+ 36.5)	1.4(B+ 36.5)	52	46	0.12	0.8
20	4300	5000	2.5(B+ 47.0)	2.2(B+ 47.0)	103	89	0.23	1.0
25	5800	8300	4.2(B+ 58.4)	2.9(B+ 58.4)	184	128	0.34	1.9
35	10000	14500	7.3(B+ 85.0)	5.0(B+ 85.0)	452	312	0.99	3.5
45	17000	20400	10.2(B+109.0)	8.5(B+109.0)	774	645	1.79	5.6

*There is more information on moment load ratings on page 110/111.

Order numbers

Order no.	Order key
RSP	Single rail pair

e.g. **FDC25E1500**

**Guide rails up to 4000 mm on one piece. Longer strokes are coupled.

Cassette + double rail

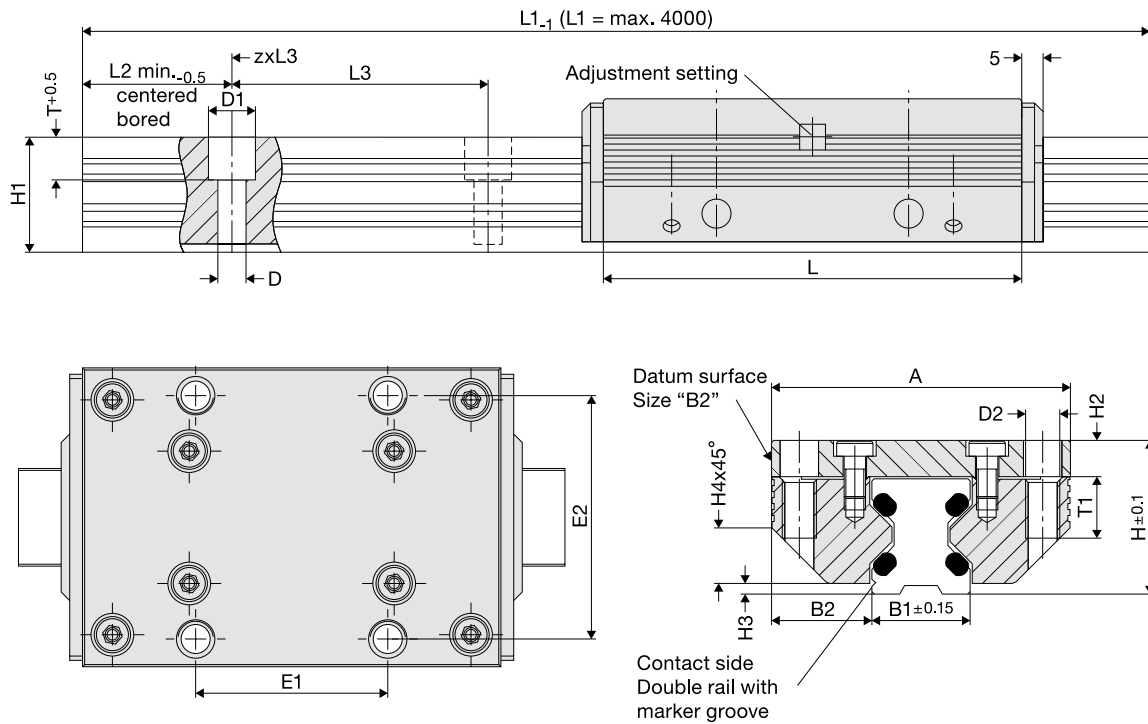

Dimensions

Size	Dimensions																	
	mm																	
	A	L	H	B1	B2	D	D1	D2	E1	E2	H1	H2	H3	H4	L2	L3	T	T1
25	70	98	36	23.0	23.50	6.6	11	M 8	45	57	27.0	8.5	2.5	13.0	10	60	10.0	16

Load ratings, weight

Size	Load ratings		Moment load ratings* cassette				Weight	
	N		Nm				kg	
	C	Co	Mocx	Mcx	Mocy/Mocz	Mcy/Mcz	Cassette	rail/m
25	1200	1600	25	18	35	25	0.5	1.8

Order numbers

Order no.	Order key
Cassette	Double rail
84363P	e.g. FDD25D1500

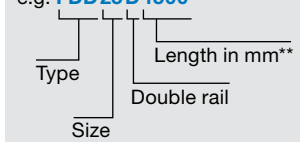

*There is more information on moment load ratings on page 110/111.

**Guide rails up to 4000 mm on one piece. Longer strokes are coupled.

Materials

	Body material	Rollers	Wipers
Standard	High-strength, anodized aluminium	Antifriction bearing steel	Plastic plate with felt wiper

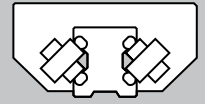

Pair of roller shoes + single rail pairs

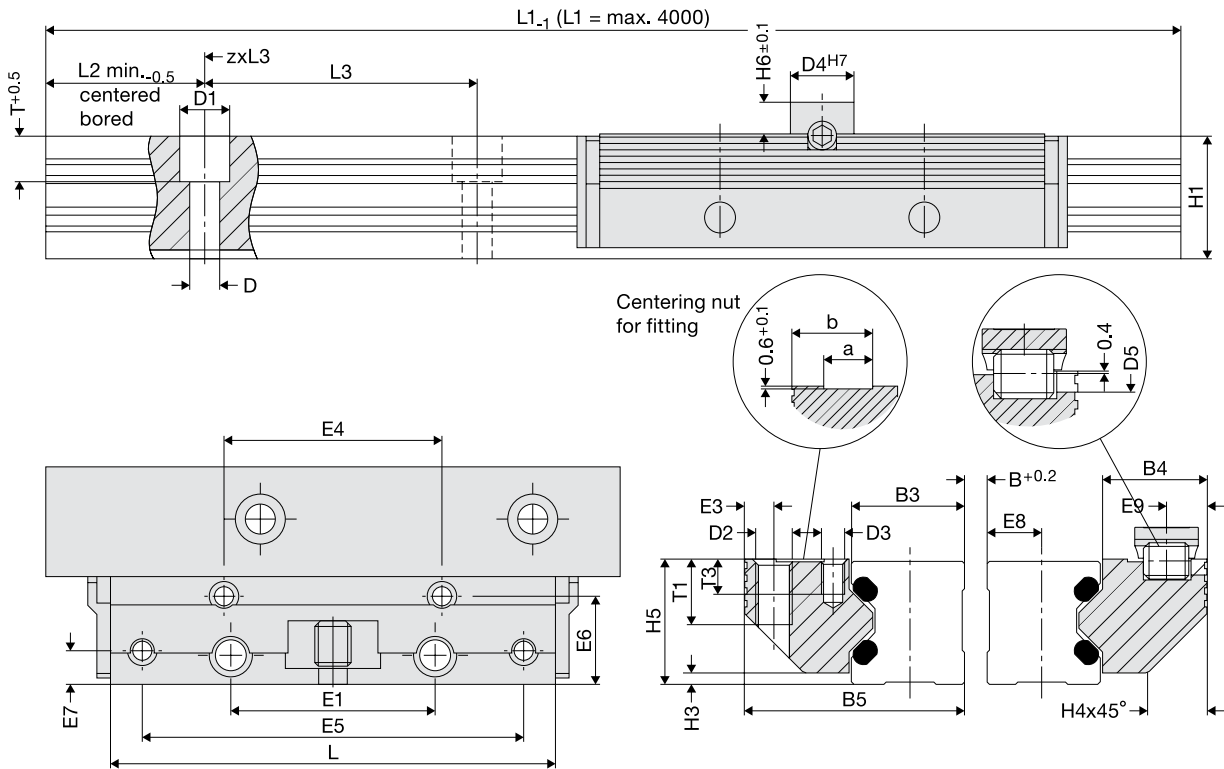

Dimensions

Size	Dimensions																	
	B5	H5	B3	B4	D3	D4	D5	E3	E4	E5	E6	E7	E8	E9	H6	T3	a	b
25	48.4	27.5	25.00	22.9	M5	14	6	6.4	48	84	19.4	7.4	12.0	8.9	7	5.0	10.5	17.5

Load ratings, weight

Size	Load ratings		Moment load ratings* RSP				Weight	
	N	Co	Nm		Nm		RSP	kg
	C	Co	Mocx	Mcx	Mocy/Mocz	Mcy/Mcz	RSP	rail/m
25	1200	1600	0.8(B+58.4)	0.6(B+58.4)	35	25	0.34	1.9

Order numbers

Order no.	Order key
RSP	Single rail pair
84367P	e.g. FDD25E1500

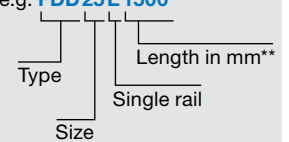

*There is more information on moment load ratings on page 110/111.

**Guide rails up to 4000 mm on one piece. Longer strokes are coupled.

Cassette + double rail

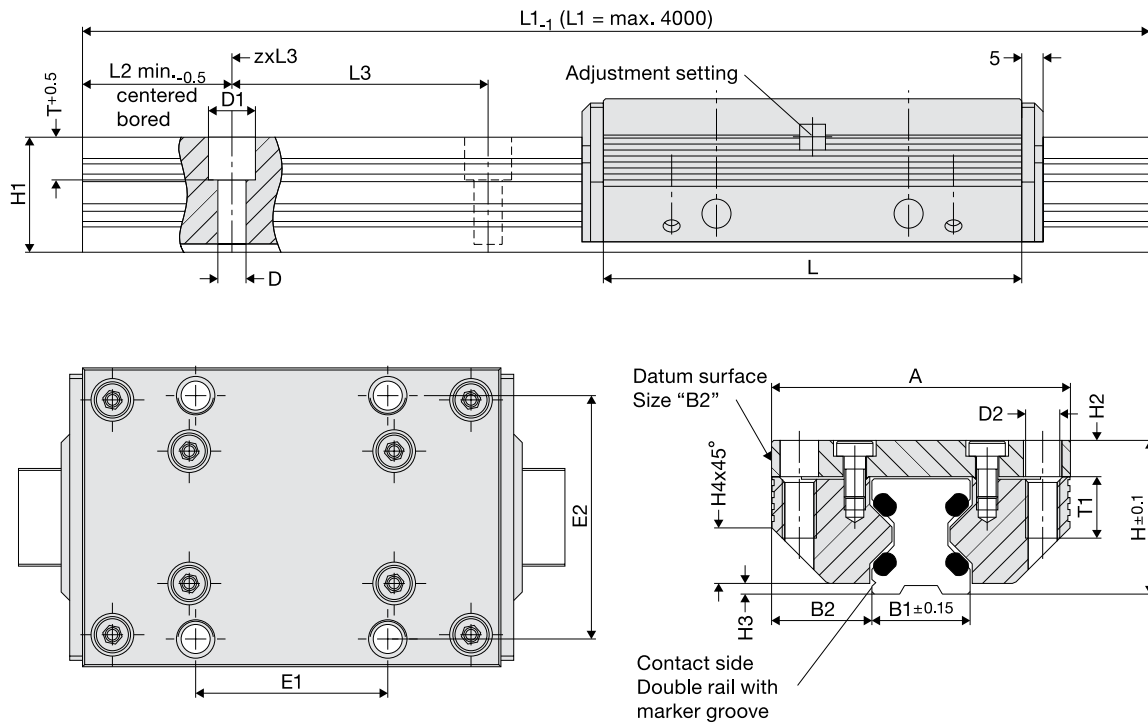

Dimensions

Size	Dimensions																	
	A	L	H	B1	B2	D	D1	D2	E1	E2	H1	H2	H3	H4	L2	L3	T	T1
12	37	64	19	12.0	12.50	3.4	6	M 4	25	30	14.7	4.0	1.4	5.5	10	40	5.5	8
15	47	78	24	15.5	15.75	4.5	8	M 5	30	38	18.7	5.0	2.0	8.0	10	60	6.0	10
20	63	92	30	21.0	21.00	5.5	10	M 6	40	53	22.6	7.0	2.0	11.0	10	60	8.0	12
25	70	98	36	23.0	23.50	6.6	11	M 8	45	57	27.0	8.5	2.5	13.0	10	60	10.0	16
35	100	135	48	32.0	34.00	9.0	15	M10	62	82	37.0	10.5	3.5	20.0	12	80	11.5	20
45	120	165	60	45.0	37.50	11.0	18	M12	80	100	46.0	13.5	4.0	22.0	16	105	14.5	24

Load ratings, weight

Size	Load ratings		Moment load ratings* cassette				Weight	
	N	N	Nm				kg	
	C	Co	Mocx	Mcx	Mocy/Mocz	Mcy/Mcz	Cassette	rail/m
12	350	400	4	3	6	5	0.1	0.4
15	600	700	8	6	12	10	0.2	0.8
20	700	900	12	9	17	14	0.4	0.9
25	1200	1600	25	18	35	25	0.5	1.8
35	2000	2500	58	44	76	58	1.4	3.2
45	4400	5500	180	140	210	170	2.5	5.5

Order numbers

Order no.	Order key
Cassette	Double rail
84494T	e.g. FDA25D1500
84396T	
84441T	
84363T	
84364T	
84365T	

*There is more information on moment load ratings on page 110/111.

**Guide rails up to 4000 mm on one piece. Longer strokes are coupled.

Materials

	Body material	Rollers	Wipers
Standard	High-strength, anodized aluminium	Antifriction bearing steel	Plastic plate with felt wiper

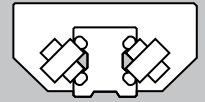

Pair of roller shoes + single rail pairs

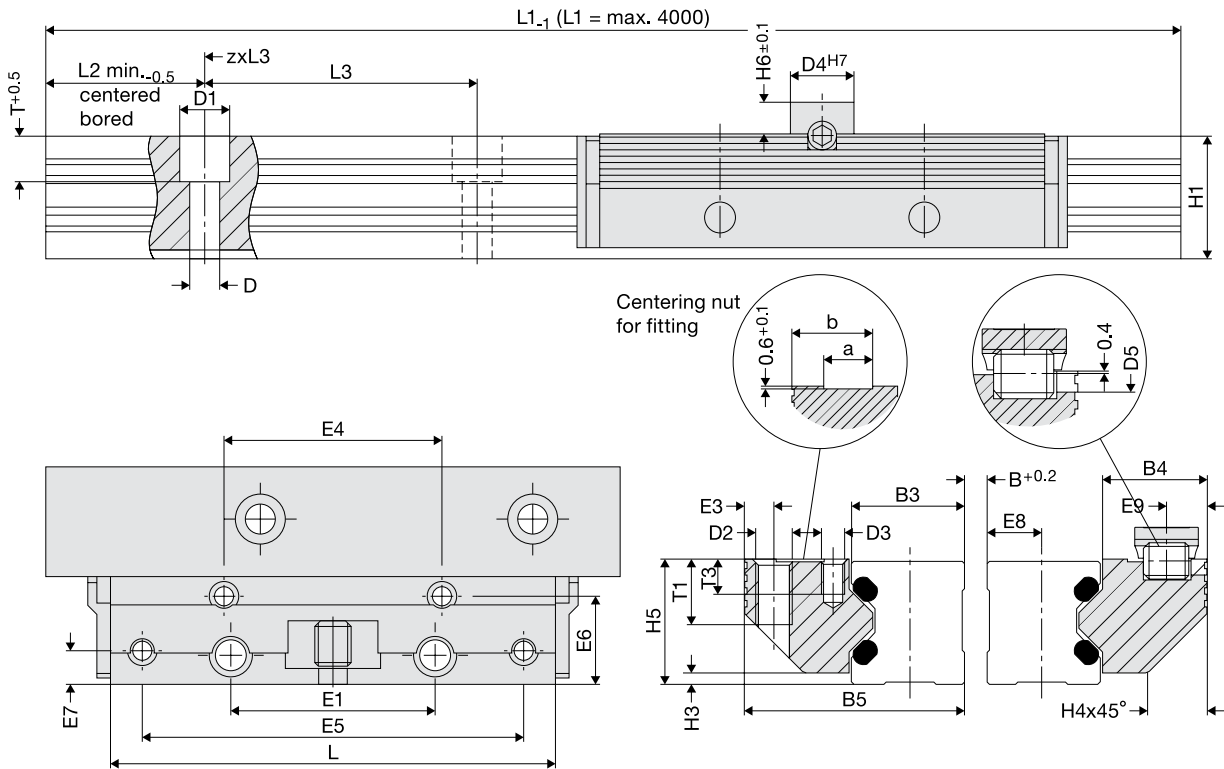

Dimensions

Size	Dimensions																	
	B5	H5	B3	B4	D3	D4	D5	E3	E4	E5	E6	E7	E8	E9	H6	T3	a	b
12	24.4	15.0	12.00	11.9	M3	8	3	3.4	29	57	9.7	3.4	5.5	4.9	4	6.0	4.5	9.5
15	30.9	19.0	15.25	15.2	M4	10	4	4.4	34	68	12.4	4.9	7.0	5.9	5	7.5	5.0	12.5
20	40.9	23.0	20.00	20.4	M5	10	4	4.9	42	80	16.9	5.9	9.5	5.9	5	8.0	7.5	16.0
25	48.4	27.5	25.00	22.9	M5	14	6	6.4	48	84	19.4	7.4	12.0	8.9	7	5.0	10.5	17.5
35	68.9	37.5	35.00	32.9	M6	14	6	8.9	67	117	28.4	8.9	17.0	8.9	7	7.5	12.5	26.0
45	82.4	46.5	45.00	36.4	M8	14	6	9.9	83	146	30.9	9.9	22.0	8.9	7	9.5	15.5	31.0

Load ratings, weight

Size	Load ratings		Moment load ratings* RSP				Weight		
	N	Co	Nm		RSP		kg		
	C	Co	Mocx	Mcx	Mocy/Mocx	Mcy/Mcz	RSP	rail/m	
12	350	400	0.20(B+ 30.3)	0.20(B+ 30.3)		6	5	0.07	0.4
15	600	700	0.35(B+ 36.5)	0.30(B+ 36.5)		12	10	0.12	0.8
20	700	900	0.40(B+ 47.0)	0.33(B+ 47.0)		17	14	0.23	1.0
25	1200	1600	0.80(B+ 58.4)	0.60(B+ 58.4)		35	25	0.34	1.9
35	2000	2500	1.20(B+ 85.0)	0.90(B+ 85.0)		76	58	0.99	3.5
45	4400	5500	2.70(B+109.0)	2.20(B+109.0)		210	170	1.79	5.6

*There is more information on moment load ratings on page 110/111.

Order numbers

Order no.	Order key
RSP	Single rail pair
84495T	e.g. FDA25E1500
84395T	
84442T	
84367T	
84368T	
84369T	Single rail

**Guide rails up to 4000 mm on one piece. Longer strokes are coupled.

Franke Dynamic

Type FDG

Aluminium Roller Guide

Non-corrosive low cost

Franke Dynamic

Cassette + double rail

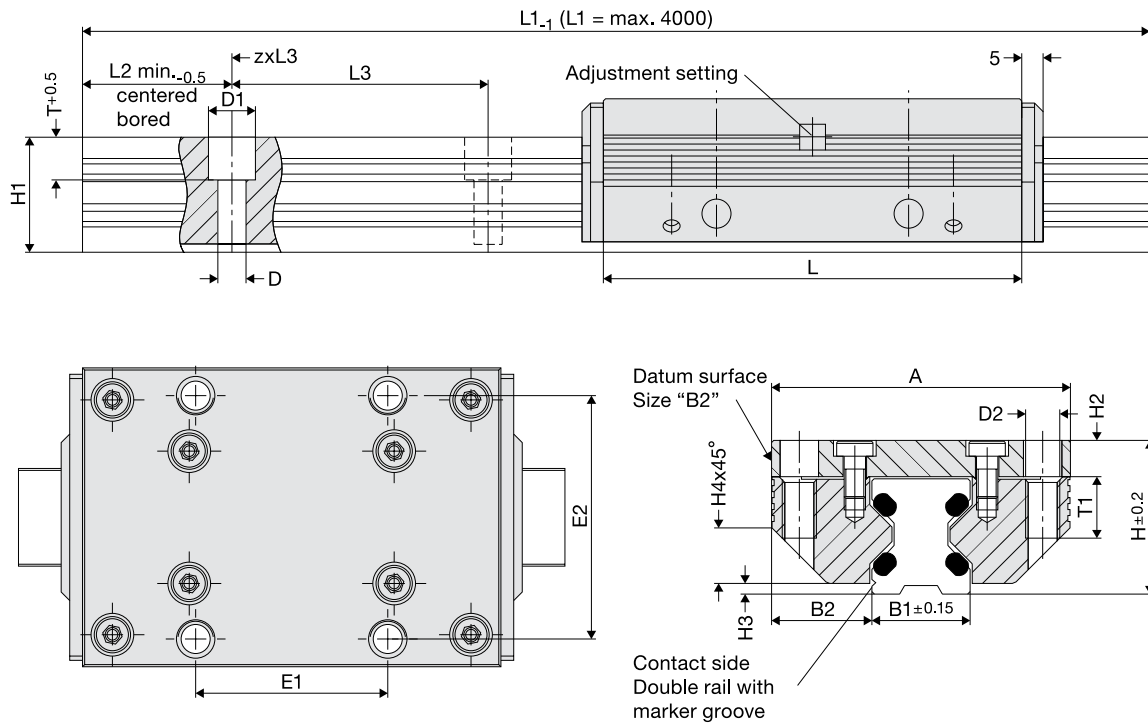

Dimensions

Size	Dimensions																	
	A	L	H	B1	B2	D	D1	D2	E1	E2	H1	H2	H3	H4	L2	L3	T	T1
12	37	64	19	12.0	12.50	3.4	6	M 4	25	30	14.7	4.0	1.4	5.5	10	40	5.5	8
15	47	78	24	15.5	15.75	4.5	8	M 5	30	38	18.7	5.0	2.0	8.0	10	60	6.0	10
20	63	92	30	21.0	21.00	5.5	10	M 6	40	53	22.6	7.0	2.0	11.0	10	60	8.0	12
25	70	98	36	23.0	23.50	6.6	11	M 8	45	57	27.0	8.5	2.5	13.0	10	60	10.0	16
35	100	135	48	32.0	34.00	9.0	15	M10	62	82	37.0	10.5	3.5	20.0	12	80	11.5	20
45	120	165	60	45.0	37.50	11.0	18	M12	80	100	46.0	13.5	4.0	22.0	16	105	14.5	24

Load ratings, weight

Size	Load ratings		Moment load ratings* cassette				Weight	
	N	Co	Mocx	Mcx	Mocy/Mocz	Mcy/Mcz	Cassette	kg rail/m
12	620	170	1.6	5.7	2.4	8.9	0.1	0.4
15	700	230	2.5	7.5	4.0	12.0	0.2	0.8
20	940	300	4.0	13.0	6.0	19.0	0.4	0.9
25	1500	700	11.0	23.0	15.0	32.0	0.5	1.8
35	3100	1400	32.0	72.0	42.0	95.0	1.4	3.2
45	6300	2700	86.0	200.0	103.0	238.0	2.5	5.5

Order numbers

Order no.	Order key
Cassette	Double rail
84494LN	e.g. FDC25D1500
84396LN	
84441LN	
84363LN	
84364LN	
84365LN	Size

*There is more information on moment load ratings on page 110/111.

**Guide rails up to 4000 mm on one piece. Longer strokes are coupled.

Materials

	Body material	Rollers	Wipers
Standard	High-strength, anodized aluminium	Antifriction bearing steel	Plastic plate with felt wiper

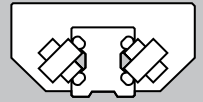

Pair of roller shoes + single rail pairs

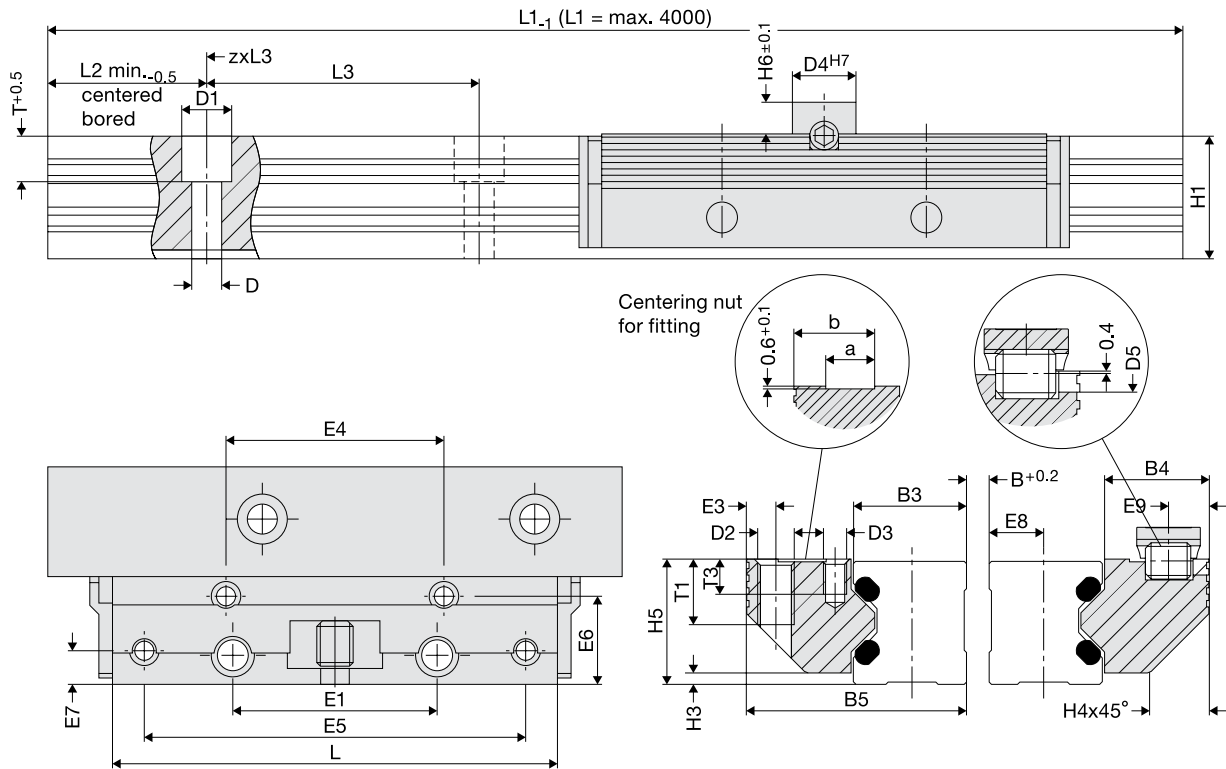

Dimensions

Size	Dimensions																	
	B5	H5	B3	B4	D3	D4	D5	E3	E4	E5	E6	E7	E8	E9	H6	T3	a	b
12	24.4	15.0	12.00	11.9	M3	8	3	3.4	29	57	9.7	3.4	5.5	4.9	4	6.0	4.5	9.5
15	30.9	19.0	15.25	15.2	M4	10	4	4.4	34	68	12.4	4.9	7.0	5.9	5	7.5	5.0	12.5
20	40.9	23.0	20.00	20.4	M5	10	4	4.9	42	80	16.9	5.9	9.5	5.9	5	8.0	7.5	16.0
25	48.4	27.5	25.00	22.9	M5	14	6	6.4	48	84	19.4	7.4	12.0	8.9	7	5.0	10.5	17.5
35	68.9	37.5	35.00	32.9	M6	14	6	8.9	67	117	28.4	8.9	17.0	8.9	7	7.5	12.5	26.0
45	82.4	46.5	45.00	36.4	M8	14	6	9.9	83	146	30.9	9.9	22.0	8.9	7	9.5	15.5	31.0

Load ratings, weight

Size	Load ratings		Moment load ratings* RSP					Weight	
	N	Co	Nm		Nm		RSP	kg	
	C	Co	Mocx	Mcx	Mocy/Mocx	Mcy/Mcz	RSP	rail/m	
12	620	170	0.08(B+ 30.3)	0.30(B+ 30.3)	2.4	8.9	0.07	0.4	
15	700	230	0.10(B+ 36.5)	0.35(B+ 36.5)	4.0	12.0	0.12	0.8	
20	940	300	0.15(B+ 47.0)	0.50(B+ 47.0)	6.0	19.0	0.23	1.0	
25	1500	700	0.35(B+ 58.4)	0.70(B+ 58.4)	15.0	32.0	0.34	1.9	
35	3100	1400	0.70(B+ 85.0)	1.50(B+ 85.0)	42.0	95.0	0.99	3.5	
45	6300	2700	1.40(B+109.0)	3.10(B+109.0)	103.0	238.0	1.79	5.6	

*There is more information on moment load ratings on page 110/111.

Order numbers

Order no.	Order key
RSP	Single rail pair

e.g. **FDC25E1500**

Single rail

Size

**Guide rails up to 4000 mm on one piece. Longer strokes are coupled.

Cassette + double rail

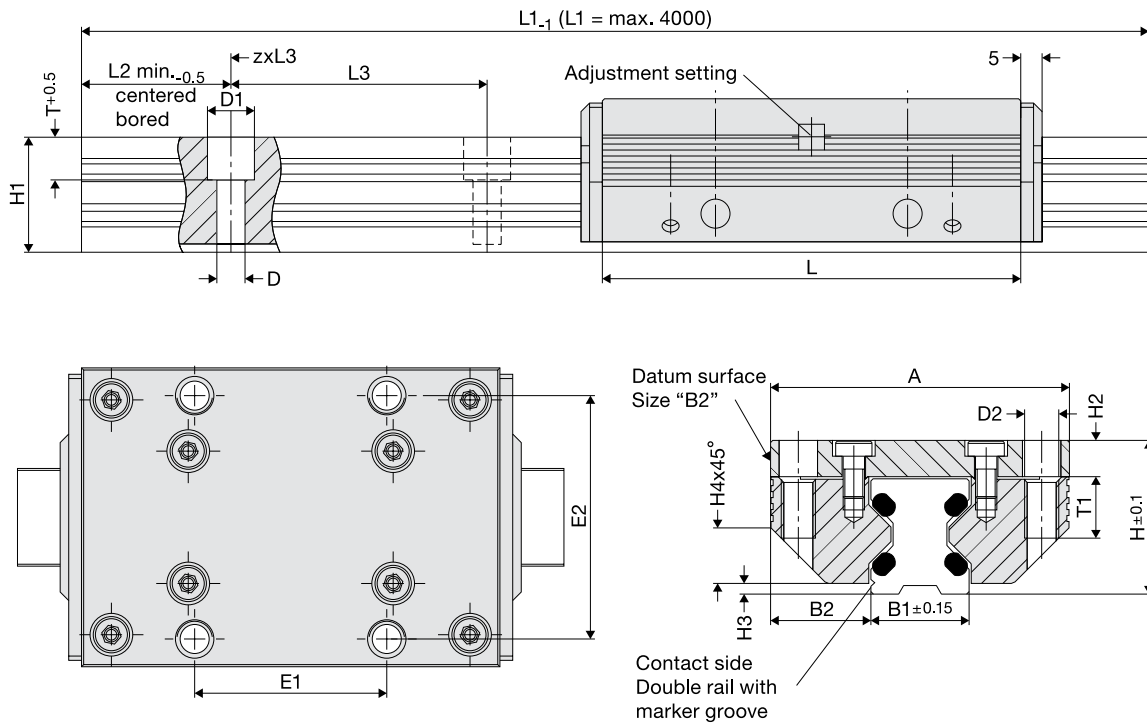

Dimensions

Size	Dimensions																	
	A	L	H	B1	B2	D	D1	D2	E1	E2	H1	H2	H3	H4	L2	L3	T	T1
25	70	98	36	23.0	23.50	6.6	11	M 8	45	57	27.0	8.5	2.5	13.0	10	60	10.0	16
35	100	135	48	32.0	34.00	9.0	15	M10	62	82	37.0	10.5	3.5	20.0	12	80	11.5	20
45	120	165	60	45.0	37.50	11.0	18	M12	80	100	46.0	13.5	4.0	22.0	16	105	14.5	24

Load ratings, weight

Size	Load ratings		Moment load ratings* cassette				Weight		
	N	Co	Mocx	Mcx	Mocy/Mocz	Mcy/Mcz	Cassette	rail/m	
25	7500	3700	58	118		81	165	0.5	1.8
35	13400	8100	189	315		250	416	1.4	3.2
45	24300	14400	461	777		548	924	2.5	5.5

Order numbers

Order no.	Order key
84363S	Cassette Double rail
84364S	
84365S	

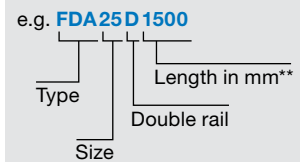

*There is more information on moment load ratings on page 110/111.

**Guide rails up to 4000 mm on one piece. Longer strokes are coupled.

Materials

	Body material	Rollers	Wipers
Standard	High-strength, anodized aluminium	Antifriction bearing steel	Plastic plate with felt wiper

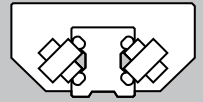

Pair of roller shoes + single rail pairs

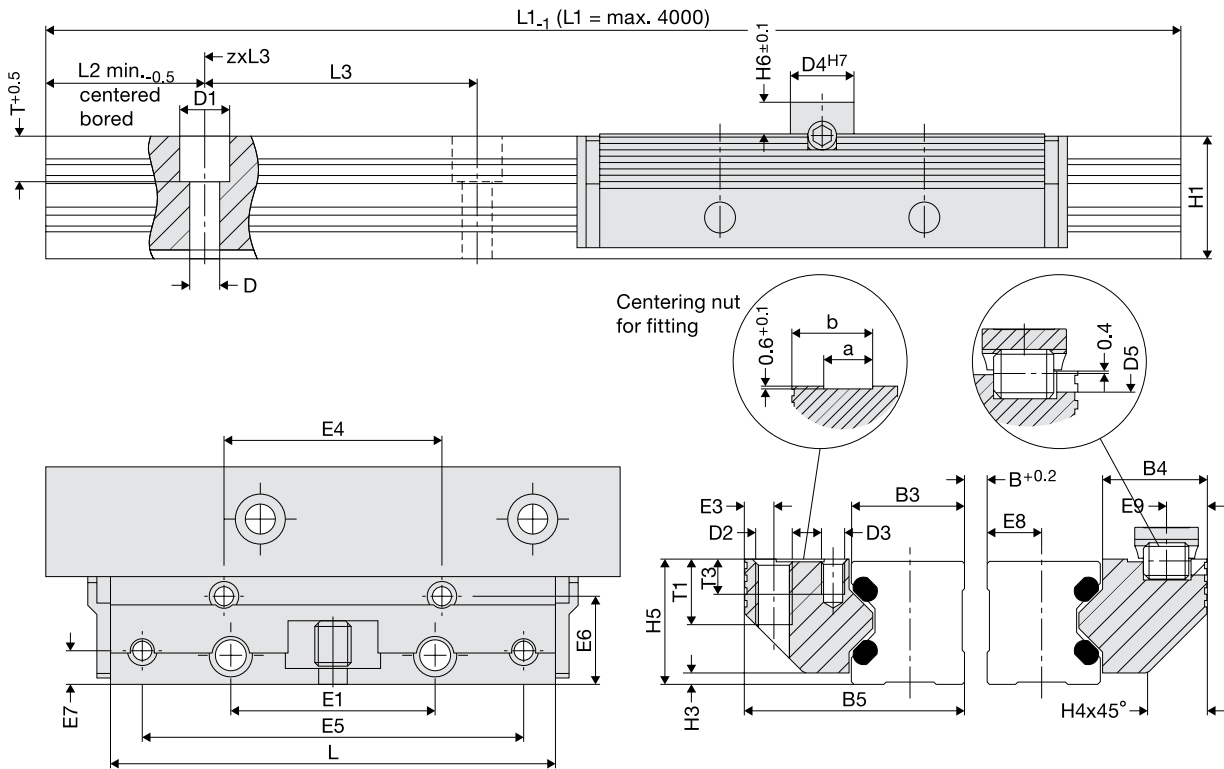

Dimensions

Size	Dimensions																	
	B5	H5	B3	B4	D3	D4	D5	E3	E4	E5	E6	E7	E8	E9	H6	T3	a	b
25	48.4	27.5	25.00	22.9	M5	14	6	6.4	48	84	19.4	7.4	12.0	8.9	7	5.0	10.5	17.5
35	68.9	37.5	35.00	32.9	M6	14	6	8.9	67	117	28.4	8.9	17.0	8.9	7	7.5	12.5	26.0
45	82.4	46.5	45.00	36.4	M8	14	6	9.9	83	146	30.9	9.9	22.0	8.9	7	9.5	15.5	31.0

Load ratings, weight

Size	Load ratings		Moment load ratings* RSP				Weight	
	N	Co	Nm		RSP		kg	
	C	Co	Mocx	Mcx	Mocy/Mocz	Mcy/Mcz	RSP	rail/m
25	7500	3700	1.8(B+ 58.4)	3.7(B+ 58.4)	81	165	0.34	1.9
35	13400	8100	4.0(B+ 85.0)	6.7(B+ 85.0)	250	416	0.99	3.5
45	24300	14400	7.2(B+109.0)	12.2(B+109.0)	548	924	1.79	5.6

Order numbers

Order no.	Order key
RSP	Single rail pair

e.g. **FDA25E1500**

Type: FDA
Size: 25
Single rail: E
Length in mm: 1500

*There is more information on moment load ratings on page 110/111.

**Guide rails up to 4000 mm on one piece. Longer strokes are coupled.

Cassette + double rail

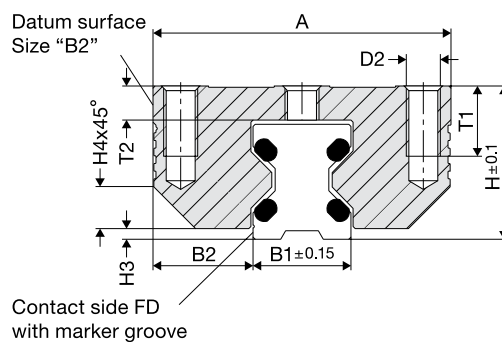
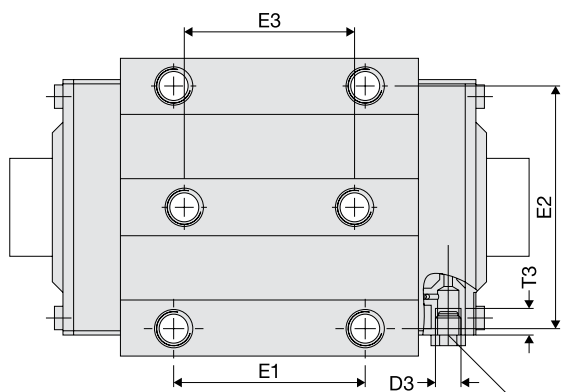
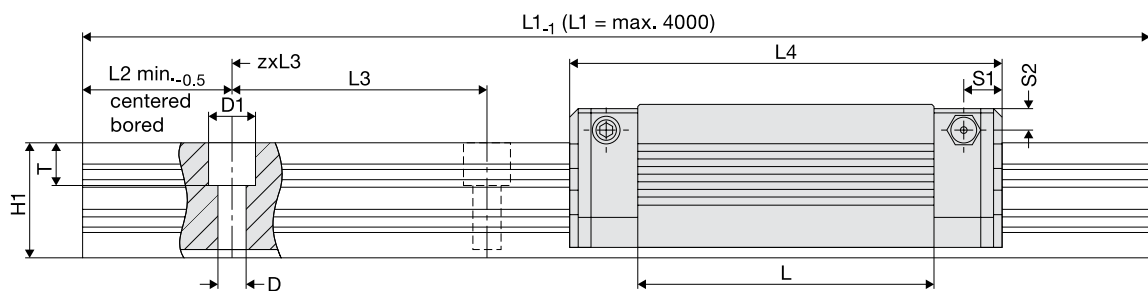

1x Funnel-type lubricating nipple
DIN 3405-D1-M6x1

Materials

	Body material	Rollers	Wipers
Standard	High-strength, anodized aluminium	Antifriction bearing steel	Plastic plate with TEEE wipers

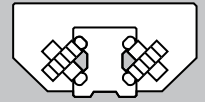

Dimensions

Size	Dimensions																							
	mm																							
	A	L	H	B1	B2	D	D1	D2	D3	E1	E2	E3	H1	H3	H4	L2	L3	L4	T	T1	T2	T3	S1	S2
25	70	70	36	23	23.5	6.6	11	M8	M6	45	57	40	27	2.5	10	10	60	102	10	16	8	6	9	6

Load ratings, weight

Size	Load ratings		Moment load ratings* cassette				Weight	
	N		Nm				kg	
	C	Co	Mocx	Mcx	Mocy/Mocz	Mcy/Mcz	Cassette	rail/m
25	23400	25000	392	368	245	230	0.39	1.8

Order numbers

Order no.	Order key
Cassette	Double rail
84042A	e.g. FDA25D1500

*There is more information on moment load ratings on page 110/111.

**Guide rails up to 4000 mm on one piece. Longer strokes are coupled.

Recirculating element + single rail

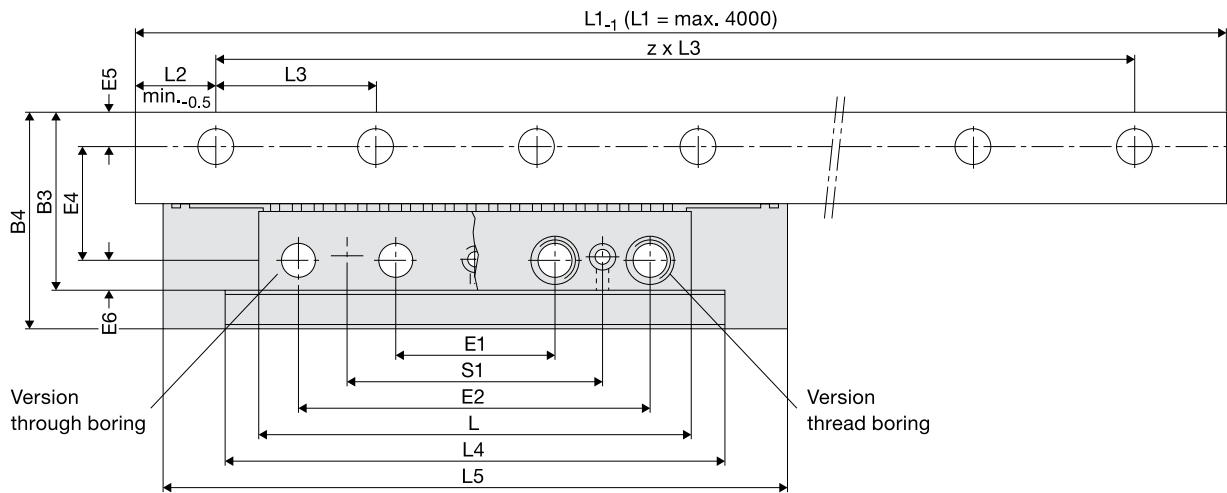

Type FRA06E / FRA08E

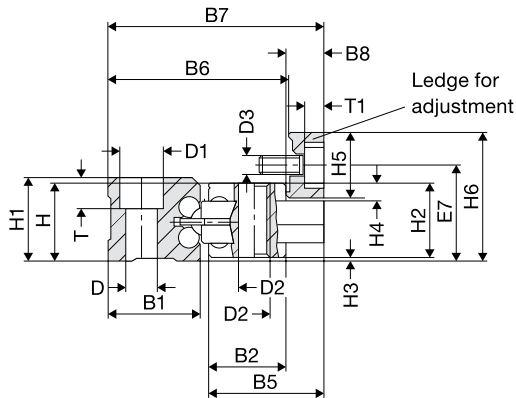

Type FRA10E / FRA13E

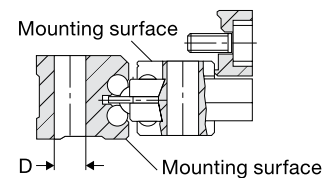

Lubrication borings

FRA06U / FRA08U
with through boring

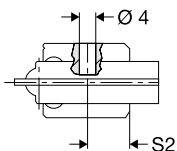

FRA10U / FRA13U
with through boring

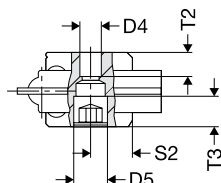

FRA06U / FRA13U
with thread boring

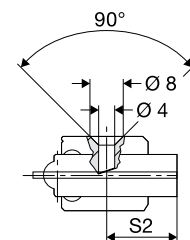

Materials

	Body material	Balls	Wipers
Standard	High-strength, anodized aluminium Steel Zinc diecasting	Antifriction bearing steel	Integrated felt wiper

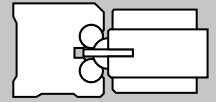

Dimensions single rail

Size	Dimensions																
	mm																
	H	B1	B3	B4	B6	B7	D	D1	E4	E5	E7	H1	H3	H6	L2	L3	T
FRA06E	16.0	20.0	36.5	44.5	38.0	44.5	5.5	10	24.5	7.0	20.7	16.7	1.0	27.7	25	50	7.0
FRA08E	21.0	26.3	47.3	57.3	48.8	57.3	6.6	11	31.8	8.5	26.0	22.2	1.0	32.5	50	100	8.5
FRA10E	23.8	24.4	51.4	63.0	51.4	62.9	9.0	-	31.4	10.0	29.4	25.0	1.0	39.4	50	100	-
FRA13E	31.2	31.6	65.1	89.5	65.1	80.1	12.0	-	41.1	12.0	37.2	33.0	1.2	48.7	50	100	-

Dimensions recirculating element

Size	Dimensions																				
	mm																				
	B2	B5	B8	D2	D3	D4	D5	E1	E2	E6	H2	H4	H5	L	L4	L5	S1	S2	T1	T2	T3
FRA06UD	15.0	23.1	8.0	6.0	M05	-	-	25	70	5	15.0	3.0	14.0	82.0	82	124	-	5.0	4.0	-	-
FRA06UM	15.0	23.1	8.0	M06	M05	-	-	25	70	5	15.0	3.0	14.0	82.0	82	124	50	7.0	4.0	-	-
FRA08UD	19.5	29.5	10.0	6.6	M06	-	-	32	84	7	20.0	5.0	15.5	100.0	104	153	-	7.0	4.8	-	-
FRA08UM	19.5	29.5	10.0	M08	M06	-	-	32	84	7	20.0	5.0	15.5	100.0	104	153	58	9.5	4.8	-	-
FRA10UD	24.4	36.0	11.5	9.0	M06	M06	M06	50	110	10	22.8	5.4	20.0	134.2	155	194	-	10.0	6.0	9.0	9.0
FRA10UM	24.4	36.0	11.5	M10	M06	-	-	50	110	10	22.8	5.4	20.0	134.2	155	194	80	11.0	6.0	-	-
FRA13UD	31.6	56.0	15.0	11.0	M08	M05	G1/8	60	140	12	30.0	7.6	23.0	169.0	178	242	-	12.0	8.0	8.0	12.0
FRA13UM	31.6	56.0	15.0	M12	M08	-	-	60	140	12	30.0	7.6	23.0	169.0	178	242	100	15.0	8.0	-	-

Load ratings, weight

Size	Load ratings		Weight		
	N	Co	kg		
	C	Co	Recirculating element/unit	rail/m	
FRA06UD	24200	37300	0.2	0.7	with through boring
FRA06UM	24200	37300	0.2	0.7	with thread boring
FRA08UD	38200	58300	0.4	1.2	with through boring
FRA08UM	38200	58300	0.4	1.2	with thread boring
FRA10UD	62000	85400	0.8	1.9	with through boring
FRA10UM	62000	85400	0.8	1.9	with thread boring
FRA13UD	103100	137700	1.7	2.9	with through boring
FRA13UM	103100	137700	1.7	2.9	with thread boring

Order numbers

Order no.	Order key
Recircl. element	Single rail
80587A	<p>e.g. FRA06E1500 Type Length in mm** Single rail Size</p>
80545A	
80588A	
80546A	
80589A	
80547A	
80590A	
80548A	

**Guide rails up to 4000 mm on one piece. Longer strokes are coupled.

Linear Tables

Type FTB

FTB06A / FTB06B

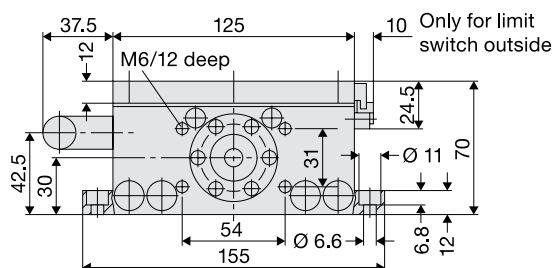
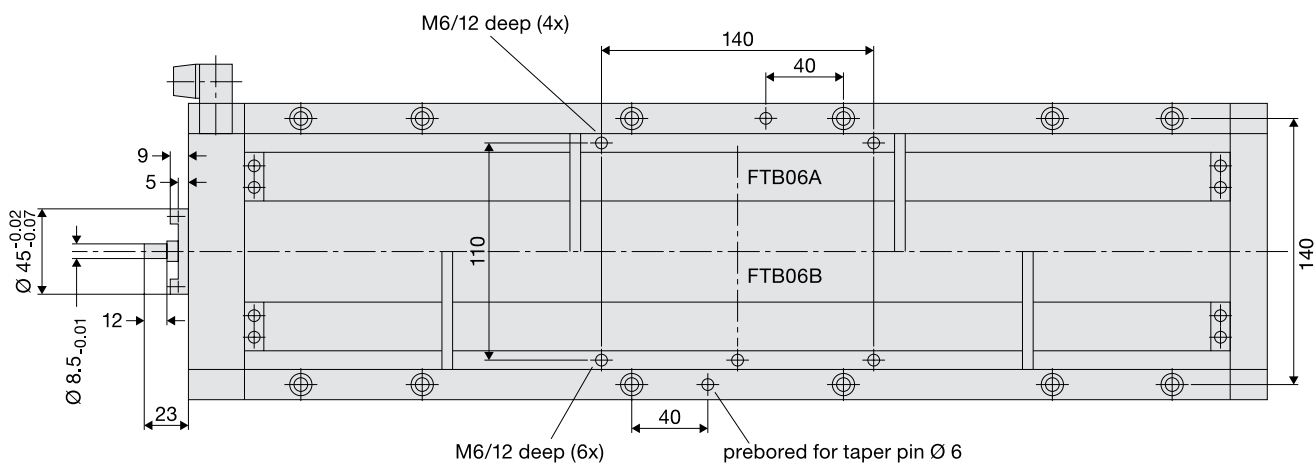
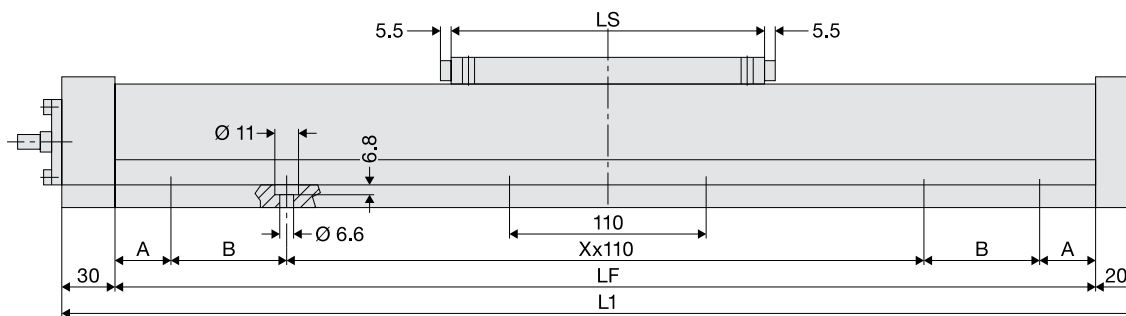

Materials

	Body material	Balls	Wipers
Standard	High-strength, anodized aluminium	Antifriction bearing steel 100Cr6	Plastic plate with felt wiper
Special		Non-corrosive steel X12CrNi177	

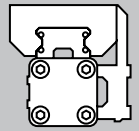

Dimensions

Stroke	Load rating N C	Torque		Dimensions						Spindle		Traverse speed		Spindle rotary speed		Fixing screws Number x size	Weight kg	Order no.	
		Mcx	Mcy, Mcz	A	B	LS	LF	L1	X x 110	Ø	pitch	Stand.	Max.	Stand.	Max.				
FTB06A																			
100	15000	670	220	30.0	72.5	165	315	365	1 x 110	16	5	8	15	1600	3000	8xM6	6.4	92621A	
200	15000	670	220	42.5		165	415	465	3 x 110	16	5	8	15	1600	3000	8xM6	7.5	92622A	
300	15000	670	220	92.5		165	515	565	3 x 110	16	5	8	15	1600	3000	8xM6	8.6	92623A	
400	15000	670	220	32.5		165	615	665	5 x 110	16	5	8	15	1600	3000	12xM6	9.7	92624A	
500	15000	670	220	82.5		165	715	765	5 x 110	16	5	8	15	1600	3000	12xM6	10.8	92625A	
700	15000	670	220	72.5		165	915	965	7 x 110	16	5	6	14	1200	2800	16xM6	13.0	92626A	
1000	15000	670	220	30.0	82.5	165	1215	1265	9 x 110	16	10	12	25	1200	2500	24xM6	16.3	92627A	
1200	15000	670	220	30.0	72.5	165	1415	1465	11 x 110	16	10	8	12	800	1200	28xM6	18.5	92628A	
1500	15000	670	220	32.5		165	1715	1765	15 x 110	16	10	6	8	600	800	32xM6	21.8	92629A	

FTB06B

100	30000	1380	1930	50		280	430	480	3 x 110	16	5	8	15	1600	3000	8xM6	7.5	92630A
200	30000	1380	1930	100		280	530	580	3 x 110	16	5	8	15	1600	3000	8xM6	8.6	92631A
300	30000	1380	1930	40		280	630	680	5 x 110	16	5	8	15	1600	3000	12xM6	9.7	92632A
400	30000	1380	1930	90		280	730	780	5 x 110	16	5	8	15	1600	3000	12xM6	10.8	92633A
500	30000	1380	1930	30		280	830	880	7 x 110	16	5	8	15	1600	3000	16xM6	11.9	92634A
700	30000	1380	1930	20		280	1030	1080	9 x 110	16	5	6	14	1200	2800	20xM6	14.1	92635A
1000	30000	1380	1930	60		280	1330	1380	11 x 110	16	10	12	25	1200	2500	24xM6	17.4	92636A
1200	30000	1380	1930	50		280	1530	1580	13 x 110	16	10	8	12	800	1200	28xM6	19.6	92637A
1500	30000	1380	1930	30		280	1830	1880	15 x 110	16	10	6	8	600	800	32xM6	22.9	92638A

Linear Modules

Type FTC

FTC 15-25

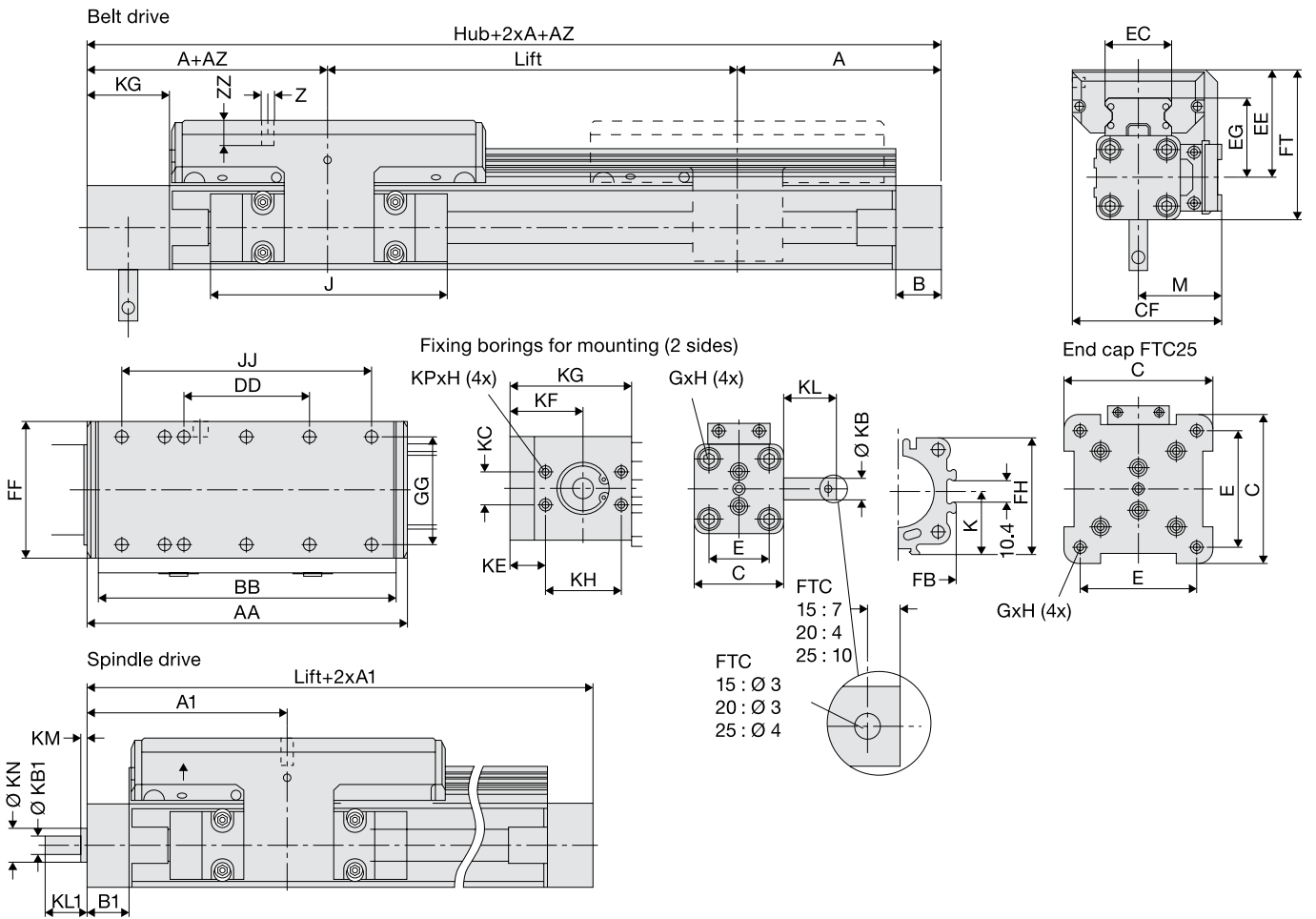

Dimensions

Size	Dimensions												
	A	A1	B	B1	C	E	G	H	J	K	M	Z	
15	125	100	22	22.0	41	27	M5	10	117	21.5	40.5	M6	
20	150	125	25	25.5	52	36	M6	12	152	28.5	49.0	M6	
25	200	175	25	33.0	87	70	M6	12	200	43.0	62.0	M6	

Size	Dimensions																										
	AA	AZ	BB	DD	CF	EC	EE	EG	FB	FF	FH	FT	GG	JJ	KB	KB1	KC	KE	KF	KG	KH	KL	KL1	KM	KN	KP	ZZ
15	154	10	144	60	72.5	32.5	53	39	40	64	39.5	73.5	50	120	10j6	6	15	22.0	37.0	57	30	24	17	2	13	M5	12
20	197	11	187	80	91.0	42.0	62	48	52	84	51.7	88.0	64	160	10j6	10	18	17.5	36.5	61	38	26	31	2	20	M6	12
25	276	24	266	120	117.0	63.0	75	57	76	110	77.0	118.5	90	240	16j6	15	32	23.5	48.5	85	50	34	43	3	28	M8	16

Materials

	Body material	Balls	Wipers
Standard	High-strength, anodized aluminium	Antifriction bearing steel 100Cr6	Plastic plate with felt wiper
Special		Non-corrosive steel X12CrNi177	

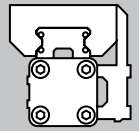

Stroke mm	Order no.					
	FTC 15		FTC 20		FTC 25	
	with: Toothed belt	Spindle	Toothed belt	Spindle	Toothed belt	Spindle
100	92700A	92700S	92734A	92734S	92768A	92768S
200	92701A	92701S	92735A	92735S	92769A	92769S
300	92702A	92702S	92736A	92736S	92770A	92770S
400	92703A	92703S	92737A	92737S	92771A	92771S
500	92704A	92704S	92738A	92738S	92772A	92772S
600	92705A	92705S	92739A	92739S	92773A	92773S
700	92706A	92706S	92740A	92740S	92774A	92774S
800	92707A	92707S	92741A	92741S	92775A	92775S
900	92708A	92708S	92742A	92742S	92776A	92776S
1000	92709A	92709S	92743A	92743S	92777A	92777S
1100	92710A	92710S	92744A	92744S	92778A	92778S
1200	92711A		92745A	92745S	92779A	92779S
1300	92712A		92746A	92746S	92780A	92780S
1400	92713A		92747A	92747S	92781A	92781S
1500	92714A		92748A	92748S	92782A	92782S
1600	92715A		92749A	92749S	92783A	92783S
1700	92716A		92750A	92750S	92784A	92784S
1800	92717A		92751A	92751S	92785A	92785S
1900	92718A		92752A	92752S	92786A	92786S
2000	92719A		92753A	92753S	92787A	92787S
2200	92721A		92755A		92789A	92789S
2400	92723A		92757A		92791A	92791S
2600	92725A		92759A		92793A	92793S
2800	92727A		92761A		92795A	92795S
3000	92729A		92763A		92797A	92797S
3200	92731A		92765A		92799A	92799S
3400	92733A		92767A			

Performance overview

Load rating: stat. / dyn. Co / C	N	3400/4200		5400/5400		15100/13500	
Max. torque (MCX / MCY, MCZ)	Nm	81/190		133/338		483/922	
Max. speed	m/s	2	0.25	3	0.25/0.5	5	0.25/0.5/1.25/2.5
Linear route per motor revolution	mm	60	5	60	5/10	100	5/10/25
Mass: basic weight/per m stroke/moved	kg	1.8/0.43/0.75	1.9/0.36/0.75	3.7/0.7/1.18	3.6/0.59/1.18	8.2/1.32/2.5	8.8/1.01/2.5
Max. rotary speed of the drive axle	min ⁻¹	2000		3000		3000	
Max. effective power FX < 1 m/s	N	55	250	150	600	425	1500
at speed 1-2 m/s	N	50	250	120	600	375	1500
at speed > 2 m/s	N			100		300	
Basic torque (without load)	Nm	0.4	0.2	0.2	0.2/0.3	0.6	0.3/0.4/0.5
Max. permissible drive torque < 1 m/s	Nm	0.9		2.3	1.5/2.8	10	4.2/7.5/20
at speed 1-2 m/s	Nm	0.9	0.6	2		9.5	
at speed > 2 m/s	Nm			1.8		7.5	
Max. acceleration/deceleration	m/s ²	10	10	10	10	10	10
Repeat accuracy	mm/m	±0.05		±0.05		±0.05	
Positioning accuracy*	mm/m	±0.15		±0.15		±0.15	
Run accuracy	mm	±0.03/300		±0.03/300		±0.03/300	

*depends on various factors

Linear Modules

Type FTD

FTD 15-35

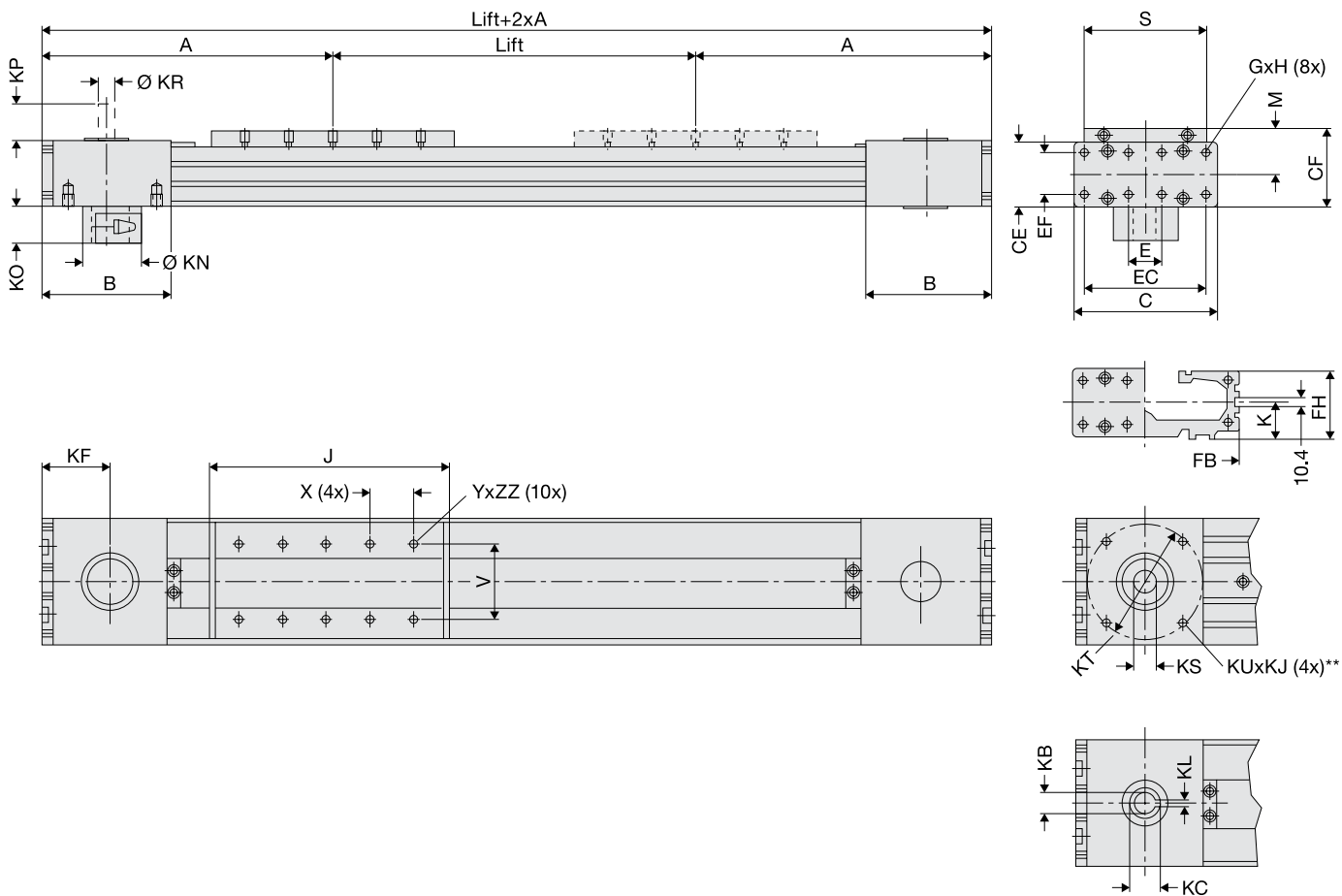

Optional: Sleeve shaft with feather key groove

Dimensions

Size	Dimensions mm												
	A	B	C	E	G	H	J	K	M	S	V	X	Y
15	218	88	93	25	M5	10	178	21.5	31	85	64	40	M6
20	262	112	116	28	M6	12	218	28.5	38	100	64	40	M6
35	347	147	175	18	M6	12	263	43.0	49	124	90	60	M6

Size	Dimensions mm																		
	CE	CF	EC	EF	FB	FH	KF	KB*	KC	KL	KJ	KN	KO	KP	KR	KS*	KT	KU	ZZ
15	42	52.5	79	27	92	39.5	49.0	16 ^{H7}	18.3	5	8	34	21.7	30	16 ^{H7}	16 ^{H7}	82	M 8	8
20	56	66.5	100	36	116	51.7	62.0	22 ^{H7}	24.8	6	12	53	30.0	30	22 ^{H7}	22 ^{H7}	106	M10	10
35	87	92.5	158	70	164	77.0	79.5	32 ^{H7}	35.3	10	19	75	41.0	35	32 ^{H7}	32 ^{H7}	144	M12	10

Materials

	Body material	Balls	Wipers
Standard	High-strength, anodized aluminium	Antifriction bearing steel 100Cr6	Plastic plate with felt wiper
Special		Non-corrosive steel X12CrNi177	

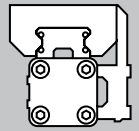

Stroke mm	Order no.		
	FTD 15 without motorisation	FTD 20 without motorisation	FTD 35 without motorisation
100	92900A	92925A	92950A
200	92901A	92926A	92951A
300	92902A	92927A	92952A
400	92903A	92928A	92953A
500	92904A	92929A	92954A
600	92905A	92930A	92955A
700	92906A	92931A	92956A
800	92907A	92932A	92957A
900	92908A	92933A	92958A
1000	92909A	92934A	92959A
1200	92910A	92935A	92960A
1400	92911A	92936A	92961A
1600	92912A	92937A	92962A
1800	92913A	92938A	92963A
2000	92914A	92939A	92964A
2500	92915A	92940A	92965A
3000	92916A	92941A	92966A
3500	92917A	92942A	92967A
4000	92918A	92943A	92968A
4500	92919A	92944A	92969A
5000	92920A	92945A	92970A
5500	92921A	92946A	92971A
6000	92922A	92947A	92972A
6500	92923A	92948A	92973A
7000	92924A	92949A	92974A

Performance overview

Load rating: stat. / dyn. Co / C	N	3400/4200	5400/5400	18000/12500
Max. torque (MCX / MCY, MCZ)	Nm	45/274	76/460	294/1233
Max. speed	m/s	10	10	10
Max. acceleration/deceleration	m/s ²	40	40	40
Max. effective power FX < 1 m/s	N	1070	1870	3120
at speed 1-3 m/s	N	890	1560	2660
at speed > 3 m/s	N	550	1030	1940
Basic torque (without load)	Nm	1.2	2.2	3.2
Mass: basic weight/per m stroke/moved	kg	3.8/4.3/1.0	7.7/6.7/1.9	22.6/15.2/4.7
Max. permissible drive torque < 1 m/s	Nm	31	71	174
at speed 1-3 m/s	Nm	25	60	148
at speed > 3 m/s	Nm	16	39	108
Linear route per motor revolution	mm	180	240	350
Max. rotary speed of the drive axle	min ⁻¹	3000	2500	1700
Repeat accuracy	mm/m	+/-0.05	+/-0.05	+/-0.05
Positioning accuracy*	mm/m	+/-0.15	+/-0.15	+/-0.15
Run accuracy	mm	+/-0.03/300	+/-0.03/300	+/-0.03/300

*depends on various factors

Linear Motor Modules

Type FTH



FTH25A / FTH25B

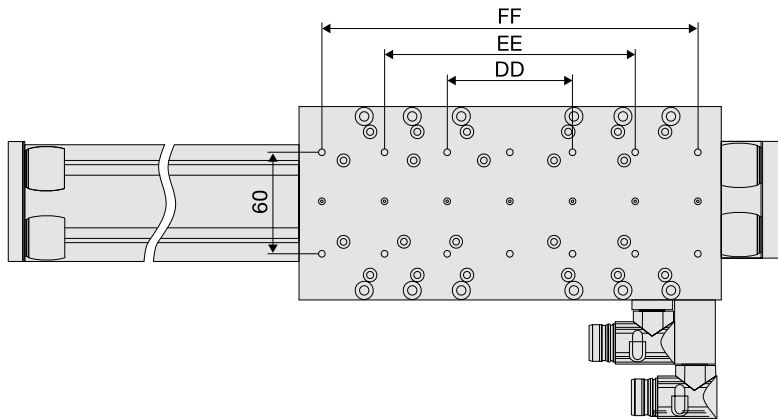
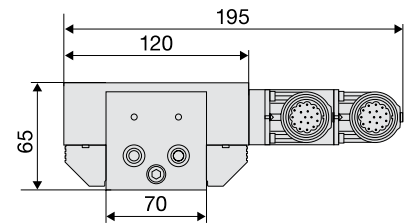
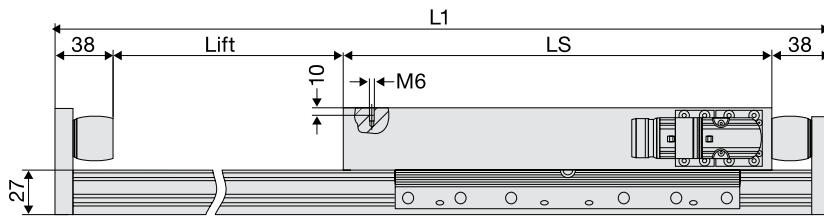

Performance overview / designs

	FTH25A	FTH25B	Optional	
Max. speed	m/s	9	4.5	
Max. acceleration	m/s ²	100	100	
Max. traverse path	mm	3625	3530	longer traverse paths on request
Weight rail	kg/m	6	6	
Weight slide bed	kg	3	5	second slide bed
Power continuous	N	61	115	
Power peak	N	162	323	
Positioning accuracy*	mm/m	0.02	0.02	
Run accuracy	mm/m	0.04	0.04	
Repeat accuracy (resolution)	mm	0.02	0.02	
Input voltage U _{dc}	V	310	310	
Continuous current I _{nc}	A	2.1	2.1	
Peak current I _{peak}	A	6	6	
Coil resistance R _{u-v}		3.8	7.6	
Coil inductance L _{u-v}	mH	20.4	40.7	
Width of pole pair	mm	24	24	
Temperature sensor	KTY81 (2000 Ohm/25 °C)			
Measuring system	1 Vpp (Auflösung 1 µm, Teilung 1 mm)			
End switch	-	-	2 end positions / 1 reference (PNP-Ö, PNP-S)	
Brakes	-	-	pneumatic	
Cover	-	-	bellows	
Cable drag chain	-	-	plastic / metal	

Special designs (e. g. water cooling, extended slide beds for greater loads, 2 slide beds etc.) on request.

Materials

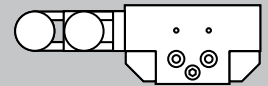

	Body material	Balls	Wipers	Cable
Standard	High-strength, anodized aluminium, steel raceways	Antifriction bearing steel 100Cr6	Plastic plate with felt wiper	
Special	Corrosion-resistant raceways	Corrosion-resistant rollers		Servoflex, drag chain-suitable up to 100 m/s ² , highly flexible

Dimensions

Stroke	Load ratings		Torque				Dimensions				Order no.		
	N		Nm		mm		mm		L1	LS		DD	EE
C	Co	Mcx	Mcy, Mcz	Mox	Moy, Moz								
FTH25A													
265	7500	3700	293	165	145	82	506	165	75	150	-	93220A	
505	7500	3700	293	165	145	82	746	165	75	150	-	93221A	
745	7500	3700	293	165	145	82	986	165	75	150	-	93222A	
985	7500	3700	293	165	145	82	1226	165	75	150	-	93223A	
1225	7500	3700	293	165	145	82	1466	165	75	150	-	93224A	
1465	7500	3700	293	165	145	82	1706	165	75	150	-	93225A	
1705	7500	3700	293	165	145	82	1946	165	75	150	-	93226A	
1945	7500	3700	293	165	145	82	2186	165	75	150	-	93227A	
2185	7500	3700	293	165	145	82	2426	165	75	150	-	93228A	
2425	7500	3700	293	165	145	82	2666	165	75	150	-	93229A	
2665	7500	3700	293	165	145	82	2906	165	75	150	-	93230A	
2905	7500	3700	293	165	145	82	3146	165	75	150	-	93231A	
3145	7500	3700	293	165	145	82	3386	165	75	150	-	93232A	
3385	7500	3700	293	165	145	82	3626	165	75	150	-	93233A	
3625	7500	3700	293	165	145	82	3866	165	75	150	-	93234A	
FTH25B													
170	15000	7400	293	461	145	228	506	260	75	150	225	93235A	
410	15000	7400	293	461	145	228	746	260	75	150	225	93236A	
650	15000	7400	293	461	145	228	986	260	75	150	225	93237A	
890	15000	7400	293	461	145	228	1226	260	75	150	225	93238A	
1130	15000	7400	293	461	145	228	1466	260	75	150	225	93239A	
1370	15000	7400	293	461	145	228	1706	260	75	150	225	93240A	
1610	15000	7400	293	461	145	228	1946	260	75	150	225	93241A	
1850	15000	7400	293	461	145	228	2186	260	75	150	225	93242A	
2090	15000	7400	293	461	145	228	2426	260	75	150	225	93243A	
2330	15000	7400	293	461	145	228	2666	260	75	150	225	93244A	
2570	15000	7400	293	461	145	228	2906	260	75	150	225	93245A	
2810	15000	7400	293	461	145	228	3146	260	75	150	225	93246A	
3050	15000	7400	293	461	145	228	3386	260	75	150	225	93247A	
3290	15000	7400	293	461	145	228	3626	260	75	150	225	93248A	
3530	15000	7400	293	461	145	228	3866	260	75	150	225	93249A	

Linear Motor Modules

Type FTH



FTH35A / FTH35B

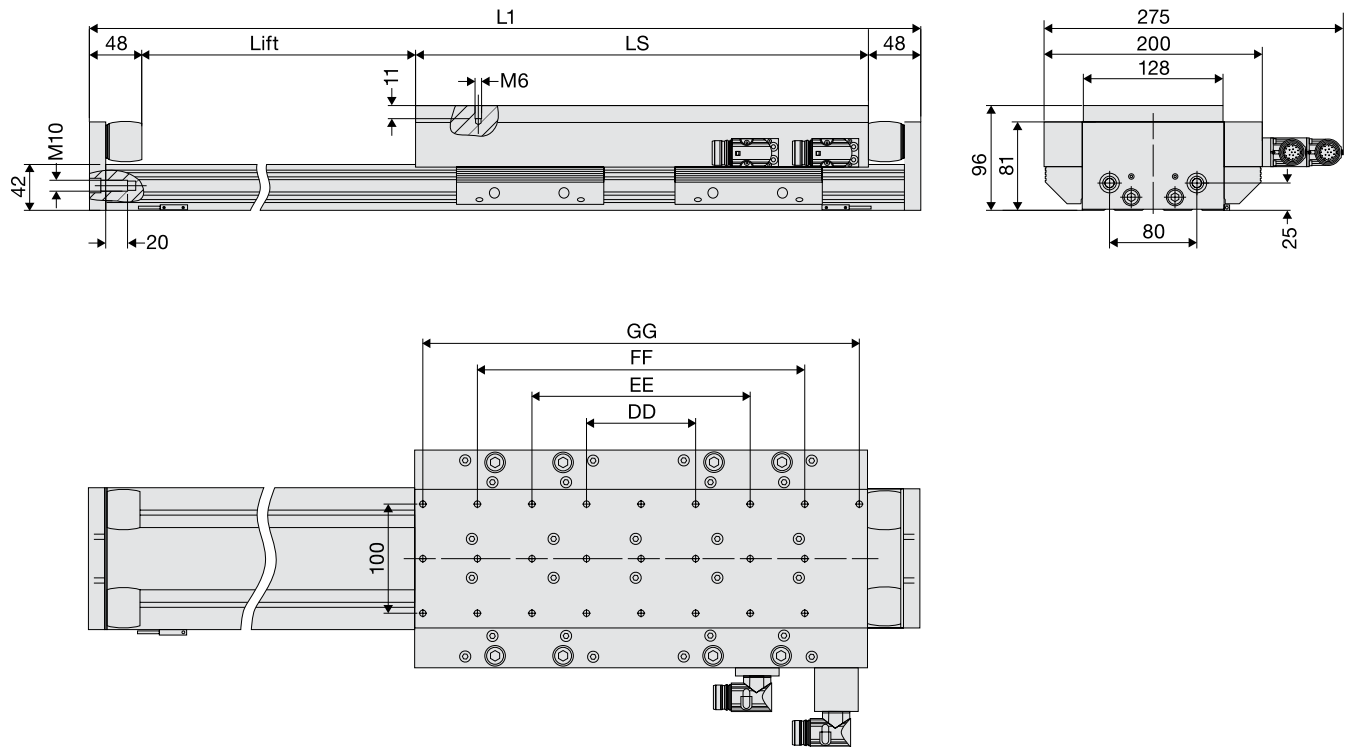

Performance overview / designs

		FTH35A	FTH35B	Optional
Max. speed	m/s	6	6	
Max. acceleration	m/s ²	100	100	
Max. traverse path	mm	3536	3361	longer traverse paths on request
Weight rail	kg/m	10	10	
Weight slide bed	kg	9	16	second slide bed
Power continuous	N	280	560	
Power peak	N	650	1300	
Positioning accuracy*	mm/m	0.02	0.02	
Run accuracy	mm/m	0.04	0.04	
Repeat accuracy (resolution)	mm	0.02	0.02	
Input voltage U _{dc}	V	560	560	
Continuous current I _{nc}	A	2.8	5.7	
Peak current I _{peak}	A	8.0	16.0	
Coil resistance R _{u-v}	Ω	7.4	3.7	
Coil inductance L _{u-v}	mH	55	27	
Width of pole pair	mm	32	32	
Temperature sensor	KTY81 (2,000 Ohm/25 °C)			
Measuring system	1 Vpp (Resolution 1 μm, pitch 1 mm)		absolute measuring system	
End switch	-		2 end positions / 1 reference (PNP-Ö, PNP-S)	
Brakes	-		pneumatic	
Cover	-		bellows	
Cable drag chain	-		plastic / metal	

Special designs (e. g. water cooling, extended slide beds for greater loads, 2 slide beds etc.) on request.

Materials

	Body material	Balls	Wipers	Cable
Standard	High-strength, anodized aluminium, steel raceways	Antifriction bearing steel 100Cr6	Plastic plate with felt wiper	
Special	Corrosion-resistant raceways	Corrosion-resistant rollers		Servoflex, drag chain-suitable up to 100 m/s ² , highly flexible

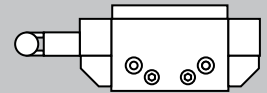

Dimensions

Stroke	Load ratings		Torque				Dimensions						Order no.
	N		Nm				mm						
	C	Co	Mcx	Mcy, Mcz	Mox	Moy, Moz	L1	LS	DD	EE	FF	GG	
FTH35A													
208	29900	34500	1100	1000	1250	1150	544	240	100	200	-	-	92870A
464	29900	34500	1100	1000	1250	1150	800	240	100	200	-	-	92871A
720	29900	34500	1100	1000	1250	1150	1056	240	100	200	-	-	92872A
976	29900	34500	1100	1000	1250	1150	1312	240	100	200	-	-	92873A
1232	29900	34500	1100	1000	1250	1150	1568	240	100	200	-	-	92874A
1488	29900	34500	1100	1000	1250	1150	1824	240	100	200	-	-	92875A
1744	29900	34500	1100	1000	1250	1150	2080	240	100	200	-	-	92876A
2000	29900	34500	1100	1000	1250	1150	2336	240	100	200	-	-	92877A
2256	29900	34500	1100	1000	1250	1150	2592	240	100	200	-	-	92878A
2512	29900	34500	1100	1000	1250	1150	2848	240	100	200	-	-	92879A
2768	29900	34500	1100	1000	1250	1150	3104	240	100	200	-	-	92880A
3024	29900	34500	1100	1000	1250	1150	3360	240	100	200	-	-	92881A
3280	29900	34500	1100	1000	1250	1150	3616	240	100	200	-	-	92882A
3536	29900	34500	1100	1000	1250	1150	3872	240	100	200	-	-	92883A
FTH35B													
289	29900	34500	2150	3000	2500	3450	800	415	100	200	300	400	92884A
545	29900	34500	2150	3000	2500	3450	1056	415	100	200	300	400	92885A
801	29900	34500	2150	3000	2500	3450	1312	415	100	200	300	400	92886A
1057	29900	34500	2150	3000	2500	3450	1568	415	100	200	300	400	92887A
1313	29900	34500	2150	3000	2500	3450	1824	415	100	200	300	400	92888A
1569	29900	34500	2150	3000	2500	3450	2080	415	100	200	300	400	92889A
1825	29900	34500	2150	3000	2500	3450	2336	415	100	200	300	400	92890A
2081	29900	34500	2150	3000	2500	3450	2592	415	100	200	300	400	92891A
2337	29900	34500	2150	3000	2500	3450	2848	415	100	200	300	400	92892A
2593	29900	34500	2150	3000	2500	3450	3104	415	100	200	300	400	92893A
2849	29900	34500	2150	3000	2500	3450	3360	415	100	200	300	400	92894A
3105	29900	34500	2150	3000	2500	3450	3616	415	100	200	300	400	92895A
3361	29900	34500	2150	3000	2500	3450	3872	415	100	200	300	400	92896A

FTH35B is also available as a heavy duty version with double load rating.

Clamping

Cassette with star grip or clamping lever for fixing to any position on the guide section. The clamping does not apply any force to the

guide system. It is used for manual devices, clamping and holding stops, instead of tools and machining parts. Let us advise you.

with star grip

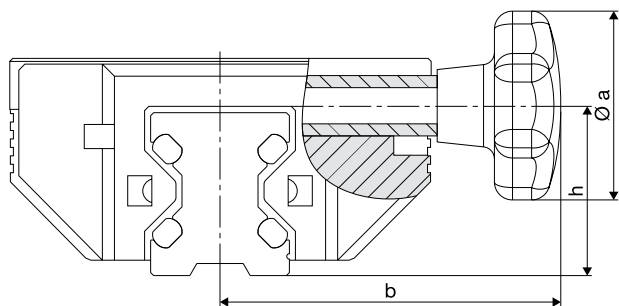

Size	Dimensions				Order no.	
	Ø a	b	h	N	Standard	Non-corrosive
15	25	41	19.0	200	84396AK	84396NK
20	25	49	23.0	250	84441AK	84441NK
25	32	56	28.0	250	84363AK	84363NK
35	50	83	38.5	350	84364AK	84364NK
45	63	101	48.0	750	84365AK	84365NK

with clamping lever

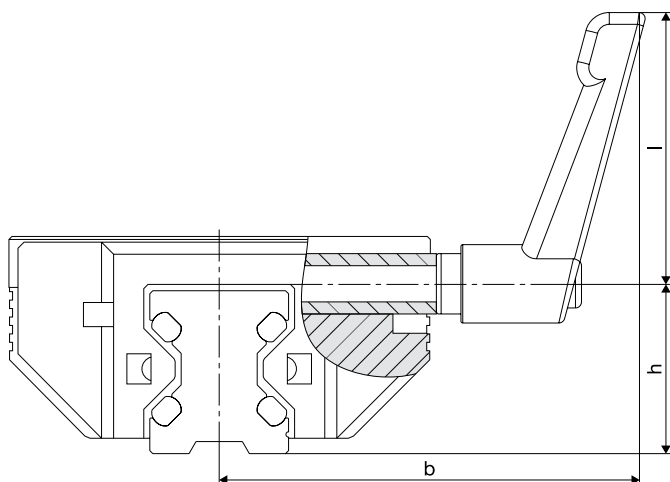

Size	Dimensions					Order no.	
	l	Wt.	b	h	N	Standard	Non-corrosive
15	45	M 5	59.5	64.0	200	84396AH	84396NH
20	45	M 5	67.5	68.0	250	84441AH	84441NH
25	45	M 6	71.0	73.0	250	84363AH	84363NH
35	63	M 8	96.0	101.5	350	84364AH	84364NH
45	78	M10	116.0	126.0	750	84365AH	84365NH

Metal Wipers

The metal wipers are inserted in the wiper plate in addition to the felt wipers and clipped. They assist removal of coarse dirt, such as metal chips, welding chips or sawdust.

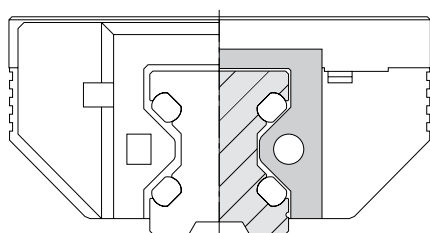

Size	Order no.
12	69126A
15	69127A
20	69128A
25	69129A
35	69130A
45	69131A

Bellows

The bellows for Aluminium Roller Guides protect the guide system from coarse dirt. They are available in any length. Fixing to the cassette and end plate is effected using glued Velcro®. The

cassette wipers are not needed. Material: synthetic cloth with one-sided polyurethane coating, temperature: contact heat +80 °C, radiant heat +120 °C.

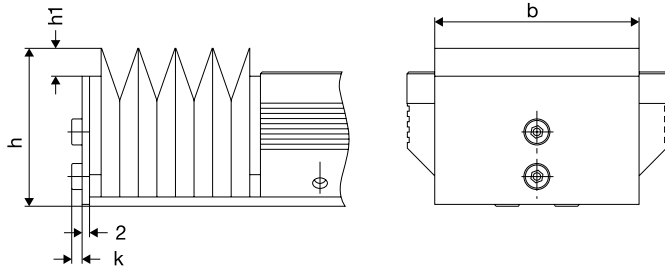

Size	Dimensions mm				Order no.
	b	h	h1	k	
15	42	31.0	7.0	2.8	on request
20	47	35.0	5.0	2.8	
25	55	42.5	6.5	2.8	
35	68	55.0	7.0	3.5	
45	87	67.0	7.0	3.5	

Stop Screws

The stop screws are screwed to the guide rails in thread (option). A fitted rubber cap cushions impact. The bore shape is delivered

offset by a half bore jump for rail lengths with initial bore dimensions less than L11 min. Material: Chloroprene rubber (Cr), colour black.

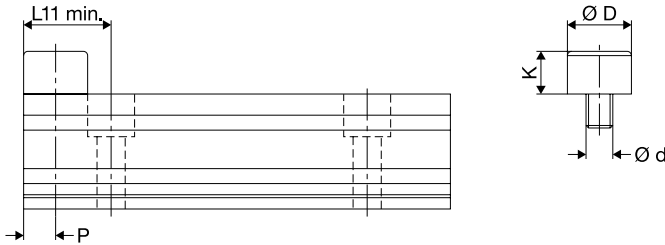

Size	Dimensions mm					Order no.
	d	D	K	L11 min.	P	
12	M 5	12	8	15.0	6.0	63504A
15	M 5	12	8	16.0	6.0	63504A
20	M 5	12	8	17.0	6.0	63504A
25	M 6	15	10	20.5	7.5	63505A
35	M 8	19	13	26.5	9.5	63506A
45	M10	24	16	33.0	12.0	63507A

Caps

The borings of the guide rails should be closed with plastic caps for best function of the wipers. These caps are included in every

delivery. They can also be ordered separately as replacements. Material: POM wear-resistant plastic, oil and ageing-resistant.

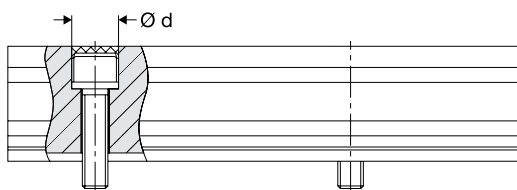

Size	Dimensions mm		Order no.
	Cylinder screw DIN912	D	
12	M 3	6	87752A
15	M 4	8	87753A
20	M 5	10	87754A
25	M 6	11	87755A
35	M 8	15	87756A
45	M10	18	87757A

Linear Modules Type FTC/FTD

Profile Fixings

MAE

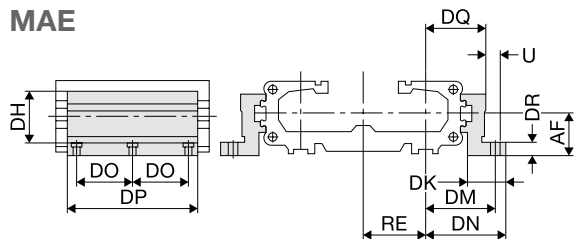

T-assembly rail

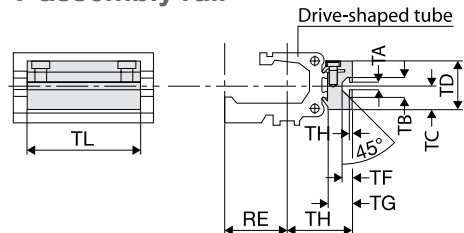

Size	Dimensions mm																		Order no.
	R	U	AF	DF	DH	DK	DM	DN	DO	DP	DQ	DR	DT	EF	EM	EN	EQ	RE	
15	M5	5.5	22	27	38	26	40	47.5	40	92	34.5	8	10	41.5	28.5	49	36	26	92981A
20	M5	5.5	30	33	46	27	46	54.5	40	92	40.5	10	10	48.5	35.5	57	43	32	92982A
25/35	M6	7.0	48	40	71	34	59	67.0	45	112	52.0	10	11	64.0	45.0	72	57	44	92983A

Size	Dimensions mm											Order no.
	RE	TA	TB	TC	TD	TE	TF	TG	TH	TL		
15	26	5.0	11.5	16	32	1.8	6.4	14.5	34.5	50	92835A	
20	32	5.0	11.5	16	32	1.8	6.4	14.5	40.5	50	92836A	
25/35	44	8.2	20.0	20	43	4.5	12.3	20.0	58.0	80	92837A	

E1

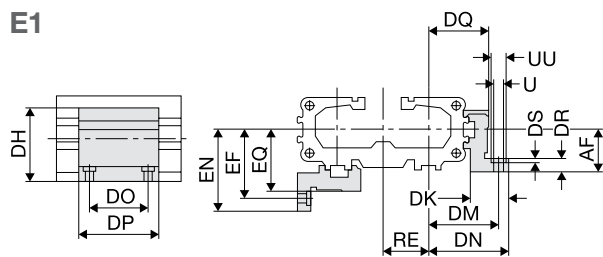

D1

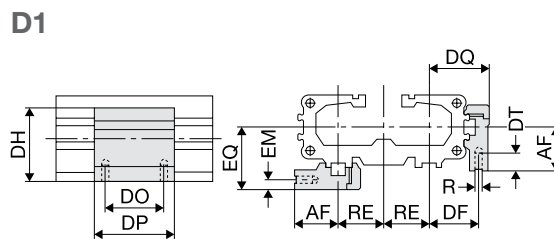

Size	Dimensions mm																			Order no.	
	R	U	UU	AF	DF	DH	DK	DM	DN	DO	DP	DQ	DR	DS	DT	EF	EM	EN	EQ		RE
E1																					
15	M5	5.5	10	22	27	38	26	40	47.5	36	50	34.5	8	5.7	10	41.5	28.5	49	36	26	92821A
20	M5	5.5	10	30	33	46	27	46	54.5	36	50	40.5	10	5.7	10	48.5	35.5	57	43	32	92826A
25/35	M6	7.0	-	48	40	71	34	59	67.0	45	60	52.0	10	-	11	64.0	45.0	72	57	44	92831A

Size	Dimensions mm																			Order no.	
	R	U	UU	AF	DF	DH	DK	DM	DN	DO	DP	DQ	DR	DS	DT	EF	EM	EN	EQ		RE
D1																					
15	M5	5.5	10	22	27	38	26	40	47.5	36	50	34.5	8	5.7	10	41.5	28.5	49	36	26	92820A
20	M5	5.5	10	30	33	46	27	46	54.5	36	50	40.5	10	5.7	10	48.5	35.5	57	43	32	92825A
25/35	M6	7.0	-	48	40	71	34	59	67.0	45	60	52.0	10	-	11	64.0	45.0	72	57	44	92830A

Cover Fixings

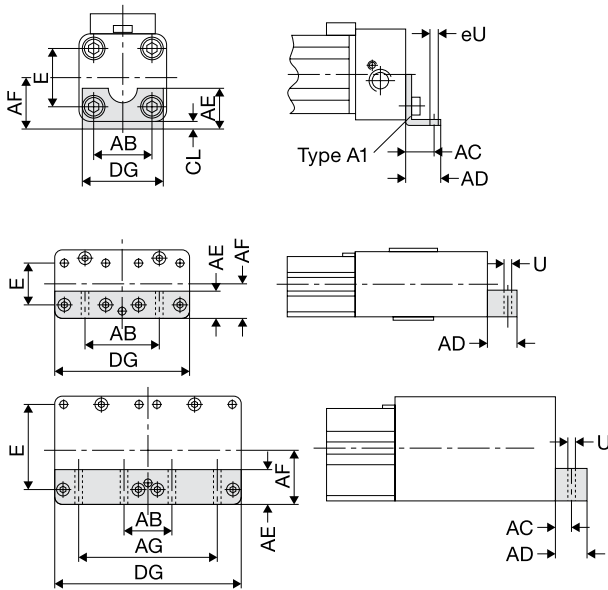

Size	Dimensions								Order no.
	E	Ø U	AB	AC	AD	AE	AF	DG	
A1	27	5.8	27	16	22	18	22	39	92810A
20	36	6.6	36	18	26	20	30	50	92813A

Size	Dimensions									Order no.
	E	Ø U	AB	AC	AD	AE	AF	AG	DG	
15	27	6.6	52	16.0	25	25	22	-	91	92978A
20	36	9.0	64	18.0	25	25	30	-	114	92979A
25/35	70	9.0	48	12.5	30	30	48	128	174	92980A

Intermediate Drive Shaft

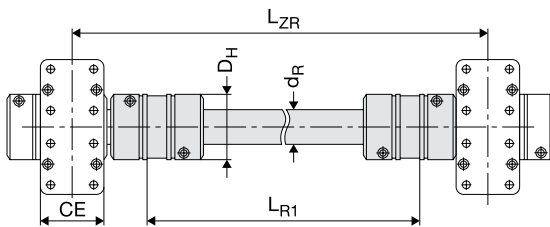

Size	Max. torque Nm	Dimensions						Order no.
		DH	Kb _{max}	LD	L _{r1}	L _{ZR}	d _R	
15	60	55	16 _{h7}	5	<3000	L _{r1} +112	30x4.0	92997A
20	60	55	22 _{h7}	5	<3000	L _{r1} +126	30x4.0	92998A
35	160	65	32 _{h7}	5	<3000	L _{r1} +167	35x4.0	92999A

End Switch

RS	RS	ES	ES
Reed closer	Reed opener	PNP closer	NPN closer
Type: RS-K	Type: RS-K	Type: ES-S	Type: ES-S
92841A	92842A	92844A	92845A
RS-S	RS-S		
92847A	92843A		
Connection cable 5 m with coupling and open end			
Signal transmitter type ES-S/RS-S			
			92846A

Type FD – Franke Dynamic

1 Designs and System Description

Aluminium Roller Guides from Franke are available as double rails with cassette or as a pair of single rails with a pair of roller shoes:

Double rail with cassette:

The double rail with cassette design is a Linear Guide ready-aligned as standard. Cassette and rail have standard connection borings.

Pair of single rails with pair of roller shoes (illustration 1):

Single rails with roller shoes are part of the construction with the advantage of a variable guide width. The mating plate is specified by the customer.



Illustration 1: Pair of Single Rails with Pair of Roller Shoes

The cassette or the pair of roller shoes of standard type FDA run on 4 crosswise needle bearing rollers on rails of tough spring steel. Other types are available for individual cases with special requirements, e.g. non-corrosive rails or also customer-specific special designs.

The Aluminium Roller Guides have lifetime lubrication. Traverse speeds of 10 m/s and accelerations of 40 m/s² can be realised. The operating temperature of the guides lies between -20 °C and +100 °C. Franke is happy to advise when solutions are requested that are suitable for temperatures outside of this range.

Cassettes mounted on rails are adjusted ex works free from clearance. It is possible to adjust the Aluminium Roller Guides to the individual load situation retrospectively using an integrated adjusting screw. The adjustment setting is best determined by measuring the slide resistance in the unloaded state (see illustration 2).



Illustration 2: Measuring Slide Resistance

The screwing of the cassette plate to the adjusting side is loosened slightly to adjust. Afterwards, the headless pin integrated in the cassette long side is readjusted. Turning the headless pin moves the roller shoe and, thus, increases or reduces the preload.

The adjustment values for the individual types are shown in table 3.6 Slide Resistances. Further details on fitting and adjusting the guide are given in the instruction manual for the Aluminium Roller Guides.

2 Dimensioning the Guides

The following parameters are needed for correct dimensioning of the guide:

- Selection of formation
- All invasive or emerging forces / torques (dynamic / static), (see illustration 3)
- Type of load (stationary, swelling, changing)
- Environmental influences (e.g. temperature, moisture) or special operation conditions (e.g. clean room, vacuum)
- Traverse speed and acceleration
- Stroke length
- Target lifetime in km

All forces and torques must be within the permissible limits. The relevant data are on the pages for the types.

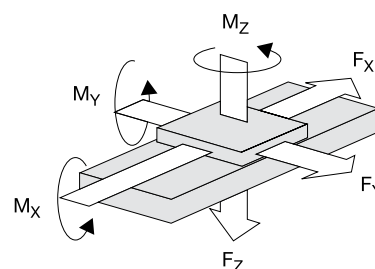

Illustration 3: Arrangement of forces and moments

Recommended safeties (for screw quality 8.8):

- Pressure load: $s > 1.2$
- Tension load: $s > 2.5$
- Moment load: $s > 4.0$

3 Notes for Mating Structure

3.1 Mating Plate for Type FD

A mating plate (bridging the roller shoes) must also be used when using single rails and roller shoes. The roller shoes and the mating plate together form the carriage.

Note on layout of the mating plate of the carriage: the roller shoes have centering grooves for better alignment during assembly. You apply a centering bar to the mating plate for this purpose (illustration 4). The dimensions for producing the centering bar are in table 1. All other dimensions, tolerances and accuracies for the guides are given on the relevant pages of the catalogue.

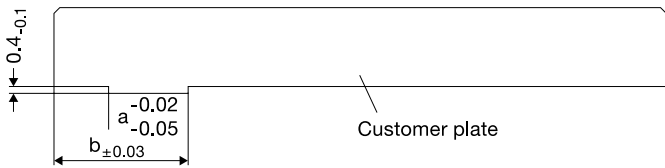

Illustration 4: Centering Shoulder

Size	a mm	b mm
12	4.5	9.6
15	5.0	12.6
20	7.5	16.1
25	10.5	17.6
35	12.5	26.1
45	15.5	31.1

Table 1: Dimensions Centering Bar

3.2 Multi-Track Formations

It is recommended to define a fixed and movable bearing site on the carriage plate for multi-track formations. This is the best way to equalise tolerances between the rails.

For example, the movable bearing side can be designed with a carrier and a stroke safety. The fixed bearing side takes on the guide function, the movable bearing side equalises parallelism and height tolerances. It is recommended to locate the drive in direct proximity to the guide side, as the drive torque is taken from this.

3.3 Mounting Surfaces

Contact and support surfaces essentially determine the function and precision of the guide. Inaccuracies can be added for running accuracy of the guide system. For example, double-track formations require precise parallelism and height alignment. The accuracies for the mounting and contact surfaces of the guides from table 2 must be maintained to guarantee running accuracy of the guide:

Size	12–20 mm	25–45 mm
Max. tolerance for parallelism	0.03	0.05
Max. evenness mounting surface	0.10	0.20

Table 2: Accuracies Contact and Support Surfaces

3.4 Fixing the Rails

Depending on the type of load the guide rails should either:

1. be screwed
2. be screwed and dowelled
3. be laid against a contact shoulder and screwed (illustration 5).

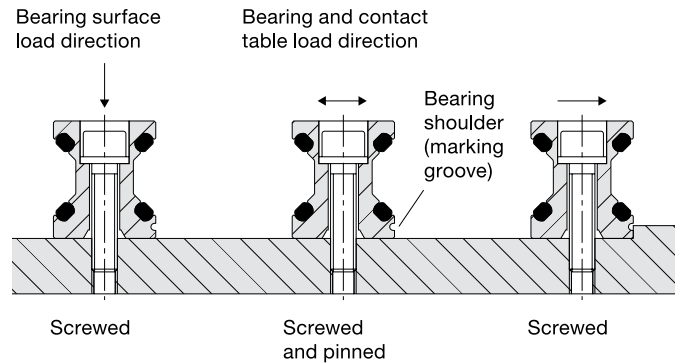

Illustration 5: Fixing Rails

The load capacity of the rails is influenced by the connections between the guide elements and the mating structure. Fixing to the mating structure is effected using screws of quality 8.8 with plain washers DIN 433.

3.5 Fitting Instructions Coupled Rails

Rails over a length of 4000 mm are coupled according to Franke standards. Butt jointing according to Franke standards guarantees a universally even bore shape and optimum usage of the rail length. Divisions are also possible to customer specifications.

Coupled rails are specially aligned with one another. Therefore, the rails have sequential numbering for the right fitting (e.g. A/1-1/1-2/2-2/E).



Illustration 6: Coupled Rails / Auxiliary Cylinders

The rails are also marked with a groove on the rail underside, which must always be on the same side. The rails must be arranged free of play. The corresponding auxiliary cylinders (illustration 6) are used for this. The dimensions for the design of the auxiliary cylinders are in table 3. The cylinders are inserted at the joints of the rails in the raceway and preloaded using a device.

Size	Auxiliary Cylinder mm
12	11
15	11
20	14
25	16
35	27
45	35

Table 3: Dimensions Auxiliary Cylinder

The relevant tightening torques for the individual screws are given in table 4.

Screws	Tightening Torque
M 3	1.1
M 4	2.5
M 5	5.0
M 6	8.5
M 8	21.0
M10	41.0
M12	71.0

Table 4: Tightening Torques Screws

3.6 Slide Resistances

Size	Slide Resistance N							
	FDA	FDB	FDC	FDD	FDE	FDG	FDH	
12	Min.	0.2	0.2	0.5	-	0.5	0.6	-
	Max.	0.4	0.4	1.0	-	3.0	0.9	-
15	Min.	0.5	0.5	0.5	-	1.0	0.5	-
	Max.	2.0	1.0	2.0	-	3.0	1.5	-
20	Min.	1.0	0.5	1.0	-	1.0	1.0	-
	Max.	2.5	1.5	2.5	-	3.0	3.0	-
25	Min.	1.5	0.5	1.5	1.5	1.5	0.5	2.5
	Max.	3.0	2.0	3.0	3.0	3.0	2.0	5.0
35	Min.	2.0	1.0	2.0	-	2.0	1.0	4.0
	Max.	4.0	2.5	4.0	-	4.0	2.5	7.0
45	Min.	2.5	2.0	2.5	-	2.5	2.0	5.0
	Max.	5.0	4.0	5.0	-	5.0	4.0	8.0

3.7 Running Accuracy and Stiffness

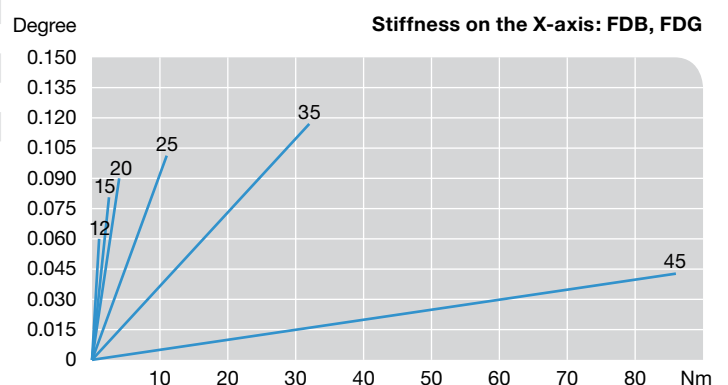
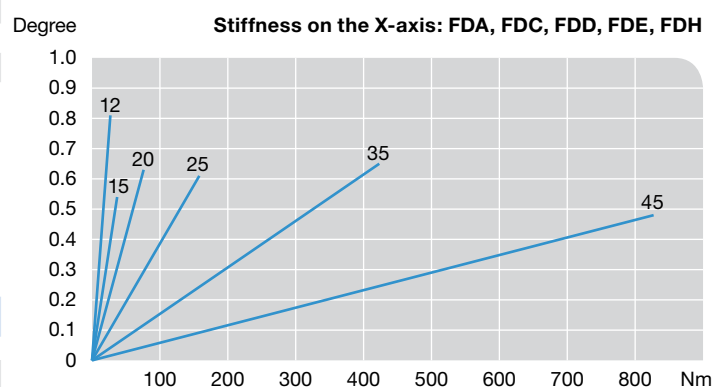
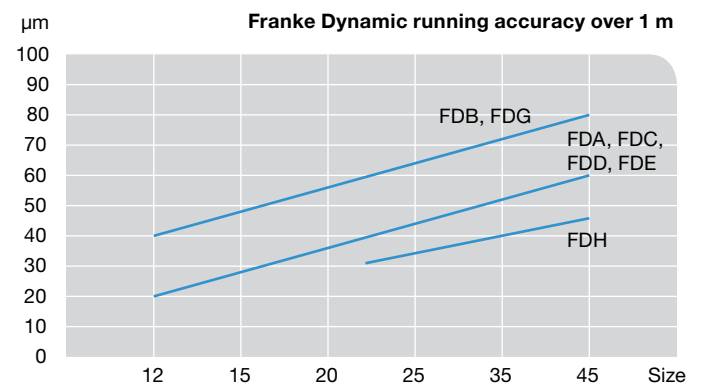

Type FP – Franke Power

1 Designs and System Description

Franke Linear Guides of the type FPA comprise double rails with cassette. The cassette has integrated recirculating rollers for high load ratings and stiffness. The rails of the type FPA are interchangeable with the rails of the Franke Aluminium Roller Guide.

Franke Recirculating Roller Guides are available in one preload class. Traverse speeds of 3 m/s and accelerations of 30 m/s² are possible. The operating temperature of the guides lies between -20 °C and +80 °C.

2 Dimensioning the Guides

The following parameters are needed for correct dimensioning of the guide:

- Selection of formation
- All invasive or emerging forces / torques (dynamic / static), (see illustration 1)
- Type of load (stationary, swelling, changing)
- Environmental influences (e.g. temperature, moisture) or special operating conditions (e.g. clean room, vacuum)
- Traverse speed and acceleration
- Stroke length
- Target lifetime in km

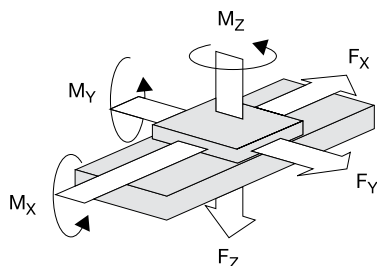

Illustration 1: Arrangement of forces and moments

All forces and torques must be within the permissible limits. The relevant data are on the pages for the individual types.

Recommended safeties (for screw quality 8.8):

- Pressure load: $s > 1.2$
- Tension load: $s > 2.5$
- Moment load: $s > 4.0$

Calculations can be performed by Franke.

3 Notes for Mating Structure

3.1 Multi-Track Formations

It is recommended to define a fixed and movable bearing site on the carriage plate for multi-track formations. This is the best way to equalise tolerances between the rails.

For example, the movable bearing side can be designed with a carrier and a stroke safety. The fixed bearing side takes on the guide function, the movable bearing side equalises parallelism and height tolerances. It is recommended to locate the drive in direct proximity to the guide side, as the drive torque is taken from this.

3.2 Mounting Surfaces

Contact and support surfaces essentially determine the function and precision of the guide. Inaccuracies can be added for running accuracy of the guide system. For example, double-track formations require precise parallelism and height alignment. The accuracies for the mounting and contact surfaces of the guides from table 1 must be maintained to guarantee running accuracy of the guide:

Size	25 mm
Max. tolerance for parallelism	0.05
Max. evenness mounting surface	0.20

Table 1: Accuracies Bearing and Contact Surfaces

All other dimensions, tolerances and accuracies for the guides are given on the relevant pages of the catalogue.

3.3 Fixing the Rails

Depending on the type of load the guide rails should either:

1. be screwed
2. be screwed and dowelled
3. be laid against a contact shoulder and screwed (illustration 2).

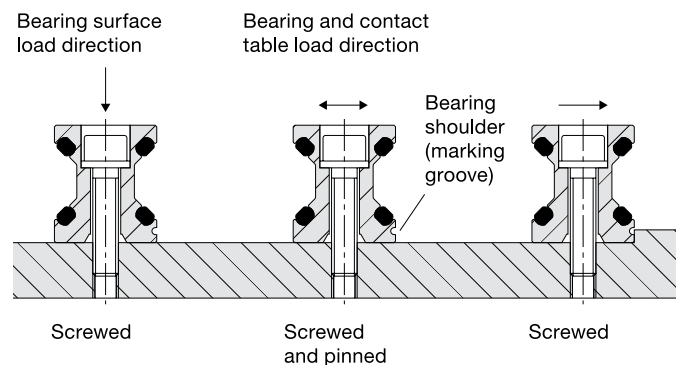

Illustration 2: Fixing Rails

The load capacity of the rails is influenced by the connections between the guide elements and the mating structure. Fixing to the mating structure is effected using screws of quality 8.8 with plain washers DIN 433.

3.4 Fitting Instructions Coupled Rails

Rails over a length of 4000 mm are coupled according to Franke standards. Butt jointing according to Franke standards guarantees a universally even bore shape and optimum usage of the rail length. Divisions are also possible to customer specifications.

Coupled rails are specially aligned with one another. Therefore, the rails have sequential production numbering for the right fitting (e.g. A/1-1/1-2/2-2/E).

The rails are also marked with a groove on the rail underside, which must always be on the same side. The rails must be arranged free of play. The corresponding auxiliary cylinders (illustration 3) are used for this. The dimensions for the design of the auxiliary cylinders are in table 2. The cylinders are inserted at the joints of the rails in the raceway and preloaded using a device.



Illustration 3: Coupled Rails/Auxiliary Cylinders

Size	Auxiliary Cylinder mm
25	16

Table 2: Dimensions Auxiliary Cylinder

The relevant tightening torques for the individual screws are given in table 3.

Screws	Tightening Torque
M6	8.5
M8	21.0

Table 3: Tightening Torques Screws

4 Lubrication

The Recirculating Roller Guides are initially lubricated ex works. After approx. 2000 km of running performance, the guides must be relubricated with 1 to 2 grams of lubricant.

5 Slide Resistances

Size	Slide resistance N	
		FP
25	Min.	17.5
	Max.	30.0

6 Running Accuracy and Stiffness

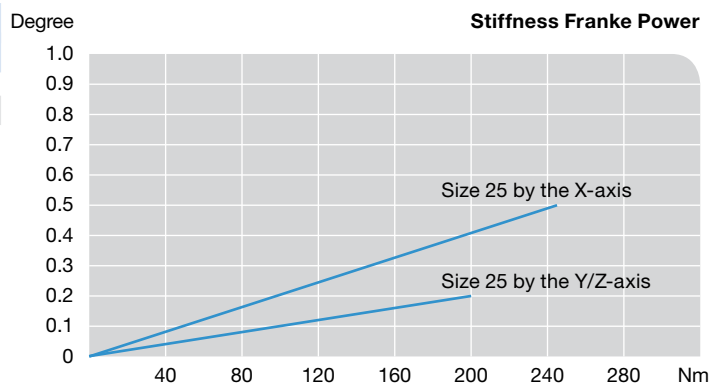
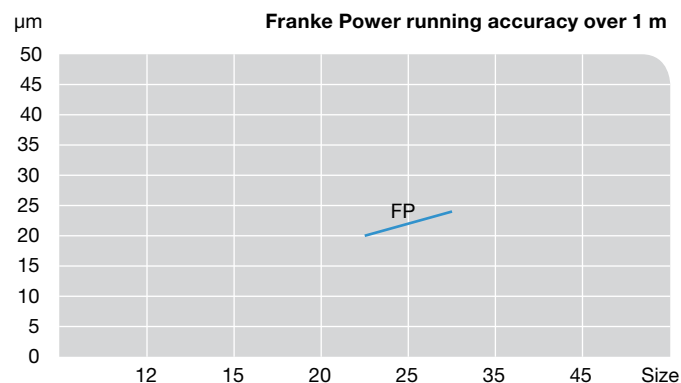

Type FR – Franke Robust

1 Designs and System Description

Aluminium Recirculating Ball Guides of type FRA comprise two individual rails and recirculating elements. The recirculating elements are mounted on the mating plate and together form the carriage. The construction of the mating plate is specified by the customer.

Guides of the type FRA are particularly robust and have high load capacity. The max. traverse speed is 3 m/s, the max. acceleration is 30 m/s². Use is possible in a temperature range of -10 °C to +80 °C.

The slide resistance can be adjusted for Linear Guides of the type FRA. The fixing screws on the slider plate on the adjustment side must be loosened. Using an optional tool the recirculating element can be moved towards the carriage plate and the adjustment is altered. The adjustment setting is best determined by measuring the slide resistance in the unloaded state.

The adjustment values are shown in table 5 Slide Resistances. Further details on fitting and adjusting the guide are given in the instruction manual for the Aluminium Recirculating Ball Guides.

2 Dimensioning the Guides

The following parameters are needed for correct dimensioning of the guide:

- Selection of formation
- All invasive or emerging forces / torques (dynamic / static), (see illustration 1)
- Type of load (stationary, swelling, changing)
- Environmental influences (e.g. temperature, moisture) or special operating conditions (e.g. clean room, vacuum)
- Traverse speed and acceleration
- Stroke length
- Target lifetime in km

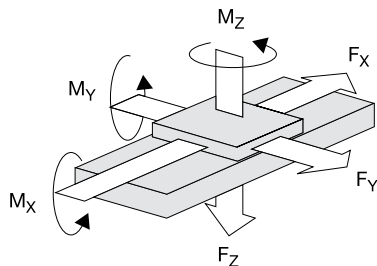

Illustration 1: Arrangement of forces and moments

All forces and torques must be within the permissible limits. The relevant data are on the pages for the individual types.

Recommended safeties (for screw quality 8.8):

- Pressure load: $s > 1.2$
- Tension load: $s > 2.5$
- Moment load: $s > 4.0$

Calculations can be performed by Franke.

3 Notes for Mating Structure

3.1 Mounting Surfaces

Contact and support surfaces essentially determine the function and precision of the guide. Inaccuracies can be added for running accuracy of the guide system. Therefore, the linearity and parallelism of the mating structure must be considered. The maximum permissible deviation across the whole stroke is 0.04 mm.

3.2 Fixing the Rails

The rails are fixed against a bearing shoulder and screwed (see illustration 2). The two guide rails must be fitted parallel to one another. This is how you control the linearity and parallelism of the rails. The maximum total error must be less than 0.06 mm.

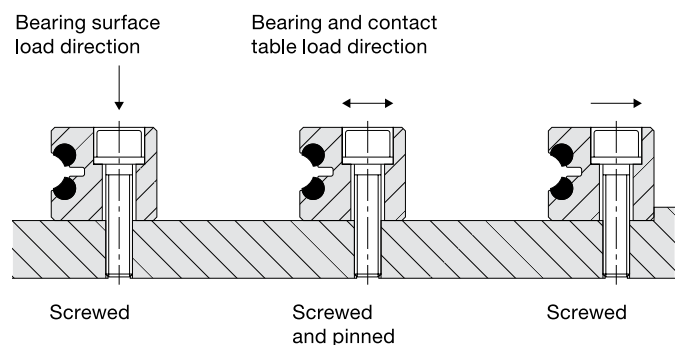

Illustration 2: Fixing Rails

The load capacity of the rails is influenced by the connections between the guide elements and the mating structure. Fixing to the mating structure is effected using screws of quality 8.8 with plain washers DIN 433.

Note: the raceways of the type FRA 08-13 can be exchanged in the event of wear. A rail's raceways must always be completely exchanged. The new raceways are ordered according to the original order or the item number of the rail.

3.3 Fitting Instructions Coupled Rails

Rails over a length of 4000 mm are coupled according to Franke standards. Butt jointing according to Franke standards guarantees a universally even bore shape and optimum usage of the rail length. Divisions are also possible to customer specifications.

Coupled rails are specially aligned with one another. Therefore, the rails have sequential production numbering for the right fitting (e.g. A/1-1/1-2/2-2/E). The top side of the rails is consistently marked with a bevel.

The rails must be evenly aligned during fitting. There must be a fitting gap between the rails. The rails should be fitted at a temperature of approx. 20 °C. The screw tightening torques from table 1 apply in this instance:

Screw	Tightening Torque
M 5	6.0
M 6	10.0
M 8	25.0
M 10	49.0

Table 1: Tightening Torques Screws FRA

There are more detailed instructions on fitting the rails in the instruction manual for Franke Linear Guides with Recirculating Balls.

4 Lubrication

The Aluminium Recirculating Ball Guides must always be coated with a film of lubricant. The system needs to be lubricated every 500 to 700 operating hours or 1 to 2 times a year.

Recirculating elements are connected to central lubrication as standard. This provides relubrication via the boring on the mounting surface.

5 Slide Resistances

Size	Slide Resistance per Pair of Recirculating Elements	
	N	FR
6	35–	45
8	60–	80
10	90–	120
13	150–	200

6 Running Accuracy

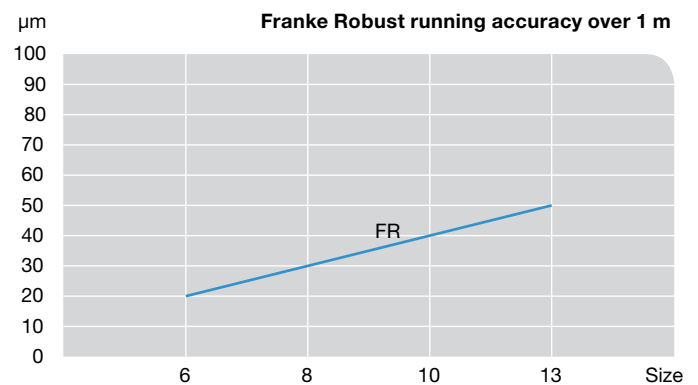

Linear Tables/Modules

1 Design

Franke Linear Systems are suitable for example for automation tasks in measuring and testing processes or for rationalisation in the handling and fitting sector. The selection ranges from strokes from 100 mm to 7000 mm, drive is effected via a spindle or belt drive. The light aluminium construction combined with the integrated Franke guide system allows high load ratings and torque loads. Precise technical details are on the relevant pages in the catalogue.

2 Area of Use

We recommend use of Franke Linear Systems with safety $s \geq 3$ for simple loads or acceleration and moment loads. A safety of $s \geq 6$ should be used for dynamic torques. You can choose any installation position. We recommend a bedstop or a brake for vertical operation.

The position accuracy of the type FTB Linear Systems is $\pm 0.025/300\text{mm}$ (IT7) in accordance with the spindle stiffness accuracy. Other accuracies are possible on request. The repeat accuracy is $\leq 0.01\text{mm}$. The run accuracy of the FTB Linear Tables is $0.02/300\text{ mm}$. Franke Linear Tables can be used in a temperature range of $-20\text{ }^{\circ}\text{C}$ to $+80\text{ }^{\circ}\text{C}$. The FTD 15 – 35 Linear Systems are suitable for permanent operation at temperatures of $-30\text{ }^{\circ}\text{C}$ to $+80\text{ }^{\circ}\text{C}$. Please contact us concerning use in other temperature ranges.

3 End Switches and Reference Switches

- Reference switches: Franke Linear Systems of type FTB have inductive proximity switches, which are set to the final stroke position. A further proximity switch can be provided as a reference switch if desired. With the type FTC and FTD Linear Modules there is the possibility of attaching a freely adjustable end switch to the outside. Franke Linear Systems are equipped with inductive end and reference switches PNP-nc 10-30VDC as standard. PNP-no, NPN-no and NPN-nc switches are available on request. The addition or integration of a length measuring system with sinus or square wave signal is possible on request. Shaft encoders can be mounted on the motor.
- Multi axis units: Franke Linear Systems can be combined to form multi-axle units. The necessary angles and adaptor plates are selected according to your needs. We supply completely fitted units, ready cabled and aligned, with other accessories on request.
- Motorisation: An array of step or servo motors can be connected to the Linear Systems. Connection flanges and couplings are modified accordingly. The customer's own motors can also be considered.

- Motor Redirection, Gears: the motor is mounted in the extension of the stroke axle as standard. For special applications, e.g. in limited space, a motor redirection can be integrated on request using a toothed belt or reversing gears.

Please call us.

4 Maintenance and Lubrication

Franke Linear Systems are low-maintenance and have lifetime lubrication ex works. No relubrication is required up to the ball screw. In the event of grease escaping through the spindle, relubrication – depending on the individual case – is required. We recommend relubrication at intervals of approx. 700 working hours with approx. 1–2 g grease. If necessary clean the inner areas and the guide tracks and coat these with grease.

Fully synthetic lubricants are preferred for long-term lubrication. Franke uses the fully synthetic special lubricant ISOFLEX TOPAS NCA52 at the factory (manuf. Klüber). We recommend high-quality lithium-saponificate grease based on mineral oil. When mixing lubricants, the compatibility of the variants must be considered with regard to type of base oil, thickening agent, base oil viscosity and NLGI class. For extreme conditions or extraordinary operating conditions (vacuum, radiation, high temperature), you should speak to us or the lubricant manufacturer.

5 Definitions

- The running accuracy is the greatest possible deviation of any one place on the moved table surface from the ideal straight lines when the entire stroke track passes (subject to the unevenness of the subconstruction).
- The position accuracy is the greatest possible deviation from the achievement of a preselected point, which is passed from a predefined point of origin.
- The repeat accuracy is the greatest possible deviation from the multiple achievement of a preselected point. The measuring system used is crucial for the level of accuracy.
- The resolution is the smallest possible traverse path. It depends on the spindle pitch, the ratio, the step angle and the classification of the measuring system. Errors in the positioning or repeat can be neutralised using the resolution. Therefore, it should always be greater than the deviation from the permissible position accuracy.

Please follow assembly and maintenance instructions. They are included with every delivery.

Type FTH

1 Design

Franke Linear Motor Modules FTH Drive are suitable for example for tasks in measuring and testing processes as well as in the handling and fitting sector. Strokes from 200 mm to 5,300 mm are available. Drive is effected via an integrated linear motor. The light aluminum construction of the integrated Franke guide system allows high load ratings and torque loads.

2 Area of Use

We recommend use with safety $S \geq 3$ for simple loads or acceleration and moment loads. A safety of $S \geq 6$ should be used for dynamic torques. You can choose any installation position. We recommend a bedstop or a brake for vertical operation.

Franke Linear Motor Modules FTH Drive can be used in a temperature range of -20 °C to $+80\text{ °C}$. Please speak to us about use in other temperature ranges.

3 Accuracy

The positioning accuracy is $\pm 0.01\text{ mm/m}$ and depends on the measuring system used. Other accuracies and measuring systems are possible. The repeat accuracy is $\leq 0.02\text{ mm}$. The running accuracy is 0.04 mm/m .

4 Dynamic

The performance given in the diagrams (page 119) can be realized with Franke Linear Motor Modules FTH Drive. These are guide values that relate to the horizontal feed motion in the trapeze and triangle positioning. We are happy to design the perfect linear motor for your application.

5 Motorization

The Linear Motor Modules FTH Drive are powered by linear servomotors without mechanical drive components. The linear motor consists of a slide element and guide element. The slide element houses the coils, the position acquisition and temperature monitoring. The drive magnets are located in the guide element.

The linear motors used are characterized by extremely high power density (highest dynamic with smallest size), thus, facilitating acceleration up to 100 m/s^2 and movement speeds up to 9 m/s .

6 Control



Dimensions		
mm		
h (incl. ventilator)	w	d (incl. connector)
345	70	243

We recommend the S700 amplifier from Kollmorgen to power the Linear Motor Modules FTH Drive. The S700 offers many special features, e. g. the free graphic Windows® software to operate the amplifier. The Auto-Tuning function also simplifies operation. A Safe Torque Off is included as standard. The S700 can memorize many different return systems and can evaluate up to three lots of position information in parallel.

You can get more information from our service team or in the internet at www.kollmorgen.com.

7 Measuring System and End and Reference Switches

Franke Linear Motor Modules are equipped with an integrated, magnetic length measuring system as standard. The positioning accuracy is $\pm 10\text{ }\mu\text{m}$ with a resolution of $\pm 1\text{ }\mu\text{m}$. Absolute measuring systems can also be fitted.

Inductive proximity switches are available to record end or reference positions, which can be freely positioned in the guide profile.

8 Multi-Module Units

Linear Motor Modules of type FTH Drive can be combined into multi-module units. The necessary angles and adaptor plates are selected according to your needs. We supply completely fitted units, ready cabled and aligned, with other accessories on request.

Please follow assembly and maintenance instructions. They are included with every delivery.

