

FERSA SOLUTIONS

NORTH AMERICAN HEAVY DUTY VEHICLES

SUMMARY

DIFFERENTIAL \ TRANSMISSION \ WHEEL END



FERSA SOLUTIONS

NORTH AMERICAN HEAVY DUTY VEHICLES

DIFFERENTIAL \ TRANSMISSION \ WHEEL END





ABOUT US

FERSA BEARINGS IS A SPANISH MULTINATIONAL COMPANY DEDICATED TO THE DESIGN, DEVELOPMENT, MANUFACTURING AND DISTRIBUTION OF HIGH PERFORMANCE BEARINGS

COMMERCIAL VEHICLE EXPERTS

The most complete range for major heavy vehicle applications.

As experts in bearings, we can offer specific bearing designs and complete solutions according to their final application: transmission, differential and wheel end.

We manufacture bearings for American, Asian and European vehicles.

INDEX

1\

DIFFERENTIAL

1.1 HEAVY DUTY DIFFERENTIAL INDEX

1.2 F-BOX DIFFERENTIAL REBUILD KIT

\Pg.06

\Pg.08

\Pg.54

2\

TRANSMISSION

2.1 HEAVY DUTY TRANSMISSION INDEX

2.2 F-BOX TRANSMISSION REBUILD KIT

\Pg.76

\Pg.78

\Pg.94

3\

WHEEL END

\Pg.130

4\

MANUFACTURER PART NUMBERS

\Pg.134



Position Identification

DIFFERENTIAL	ES
Bevel pinion front	Piñón delantero
Bevel pinion pilot	Piñón piloto
Bevel pinion rear	Piñón trasero
Cross Shaft Left	Cruceta izquierda
Cross Shaft Right	Cruceta derecha
Differential Left	Diferencial izquierda
Differential Right	Diferencial derecha
Drive Gear	Engranaje impulsor
Drive Gear Front	Engranaje impulsor delantero
Drive Gear Rear	Engranaje impulsor trasero
Drive shaft	Eje impulsor
Electric Shift	Cambio eléctrico
Helical Gear	Engranaje helicoidal
Idler Gear	Engranaje
Idler Gear Front	Engranaje loco delantero
Idler Gear Rear	Engranaje loco trasero
Input Gear	Engranaje de entrada
Input Shaft	Eje de entrada
Input Shaft Front	Eje de entrada delantero
Input Shaft Rear	Eje de entrada trasero
Inter Axle	Eje intermedio
Inter Differential	Interdiferencial
Oil Pump Idler Gear	Engranaje bomba aceite
Outer Pinion Support	Soporte piñón exterior
Output Shaft	Eje de salida
Output Shaft Front	Eje de salida delantero
Output Shaft Rear	Eje de salida trasero
Pinion Forward	Piñón delantero
Power Divider	Divisor de potencia
Power Divider Case Intermediate	Carcasa divisor de potencia - intermedio
Power Divider Front Side Gear Thrust	Engranaje axial del divisor de potencia - delantero
Power Divider Intermedial Disc Rear	Disco intermedio divisor potencia - trasero
Rear Side Gear	Engranaje trasero
Thrushaft	Eje intermedio

TRANSMISSION	ES
1st Gear	1ª marcha
2nd Gear	2ª marcha
3rd Gear	3ª marcha
4th Gear	4ª marcha
5th Gear	5ª marcha
6th Gear	6ª marcha
Aux. 1st Gear	1ª marcha auxiliar
Aux. 2nd Gear	2ª marcha auxiliar
Aux. 3rd Gear	3ª marcha auxiliar
Aux. Countershaft	Eje intermedio auxiliar
Aux. Countershaft Front	Eje secundario delantero auxiliar
Aux. Countershaft Rear	Eje secundario trasero auxiliar
Aux. Drive Gear	Engranaje auxiliar impulsor
Aux. Mainshaft	Eje principal auxiliar
Aux. Mainshaft Front	Eje principal auxiliar delantero
Aux. Mainshaft Pilot	Eje principal auxiliar piloto
Aux. Mainshaft Rear	Eje principal auxiliar trasero
Aux. Mainshaft Thrust	Eje principal auxiliar axial
Aux. Range Shaft Quill Front	Acoplamiento del eje de distribución auxiliar delantero
Clutch Pilot	Embrague
Clutch Release	Embrague
Clutch Release Shaft	Embrague
Compound Case Countershaft Front	Carcasa eje secundario delantero
Compound Case Countershaft Rear	Carcasa eje secundario trasero
Constant Gear	Engranaje
Countershaft Center	Eje intermedio central
Countershaft Front	Eje intermedio delantero
Countershaft High Range	Eje intermedio de alto rango
Countershaft Low Range	Eje intermedio de bajo rango
Countershaft Rear	Eje intermedio trasero
Crossover Lever	Palanca
Driveshaft Rear	Eje impulsor trasero
Front Cover	Cubierta delantera
Front Driveshaft Front	Eje impulsor delantero - delantero

Position Identification

TRANSMISSION	ES
Front Driveshaft Rear	Eje impulsor delantero - trasero
Front Output Shaft Front	Eje salida delantero - delantero
Front Output Shaft Rear	Eje salida delantero - trasero
High-Low Hub	Buje
Idler Gear Front	Engranaje loco delantero
Idler Gear Rear	Engranaje loco trasero
Idler Shaft Front	Eje loco delantero
Idler Shaft Rear	Eje loco trasero
Input Shaft	Eje de entrada
Input Shaft Front	Eje de entrada delantero
Input Shaft Pilot	Eje de entrada piloto
Input Shaft Rear	Eje de entrada trasero
Intermediate Gear	Engranaje intermedio
Intermediate Shaft	Eje intermedio
Intermediate Shaft Front	Eje intermedio delantero
Intermediate Shaft Rear	Eje intermedio trasero
Low Range	Low Range
Lower Output Shaft Front	Eje de salida inferior - delantero
Lower Output Shaft Rear	Eje de salida inferior - trasero
Main Drive Gear	Engranaje eje principal impulsor
Main Drive Gear Pilot	Engranaje eje principal impulsor - piloto
Mainshaft	Eje principal
Mainshaft Front	Eje principal delantero
Mainshaft Gear	Engranaje eje principal
Mainshaft Pilot	Piloto eje principal
Mainshaft Rear	Eje principal trasero
Mainshaft Rev. Gear	Eje principal marcha atrás
Output Shaft	Eje de salida
Output Shaft Center	Eje de salida central
Output Shaft Front	Eje de salida delantero
Output Shaft Pilot	Eje de salida piloto
Output Shaft Rear	Eje de salida trasero
Range Gear	Engranaje de distribución

TRANSMISSION	ES
Range Shaft Quill Front	Acoplamiento del eje de distribución delantero
Rear Countershaft	Eje secundario trasero
Rear Countershaft Front	Eje secundario trasero - delantero
Rear Countershaft Rear	Eje secundario trasero - trasero
Rear Driveshaft Front	Eje impulsor trasero - delantero
Rear Driveshaft Rear	Eje impulsor trasero - trasero
Rev. Gear	Marcha atrás
Rev. Gear Thrust	Marcha atrás axial
Rev. Idler Front	Marcha atrás delantero
Rev. Idler Gear	Engranaje marcha atrás
Rev. Idler Rear	Marcha atrás trasero
Rev. Idler Thrust	Marcha atrás axial
Rev. Shaft	Eje marcha atrás
Shift Rail	Eje de la palanca de cambios
Speed Gear	Engranaje directo
Splitter	Splitter
Splitter Gear Sleeve	Acoplamiento
Synchro Hub Thrust	Buje sincronizador
Upper Output Shaft Front	Eje salida superior delantero
Upper Output Shaft Rear	Eje salida superior trasero

1\

1.1 HEAVY DUTY DIFFERENTIAL INDEX

BRAND	Pg.
ALLIANCE / DETROIT / FREIGHTLINER	8
DANA	8
EATON	13
GMC	28
INTERNATIONAL HARVESTER/ NAVISTAR	28
MACK	29
MERITOR	32
VOLVO	53
WHITE	53

1.2 F-BOX DIFFERENTIAL REBUILD KIT

Pg.
54



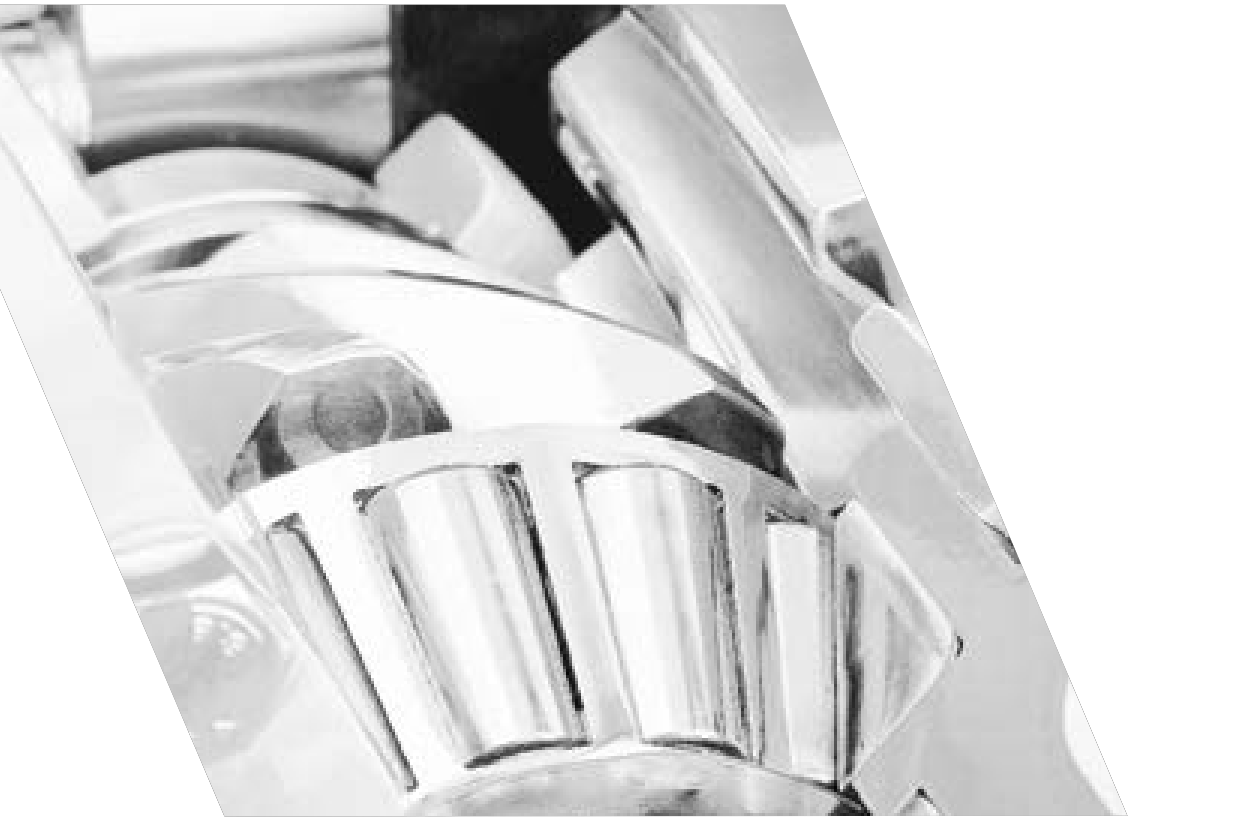

1.1 \

Heavy Duty Differential Index

Axle Model	Type/Cap.	Notes	Fersa Bearing Kit	Pg.
Alliance / Detroit / Freightliner				
ARS13-2	R-13,000		FDRK 651 OB	69
ARS15-2	R-15,000		FDRK 651 OB	69
ARS17.5-2	R-17,500		FDRK 651 OB	69
ARS17.5-4	R-17,500		FDRK 650R OB	69
ARS19-2	R-19,000		FDRK 651 OB	69
ARS19-4	R-19,000		FDRK 650R OB	69
ARS20-4	R-20,000		FDRK 650R OB	69
ARS21-2	R-21,000		FDRK 651 OB	69
ARS23-4	R-23,000		FDRK 650R OB	69
ART34-4	RF-34,000	Before 2008	FDRK 650F OB	69
	RF-34,000	After 2008	FDRK 650FA OB	
	RR-34,000		FDRK 650R OB	
ART40-4	RF-44,000	Before 2008	FDRK 650F OB	69
	RF-44,000	After 2008	FDRK 650FA OB	
	RR-44,000		FDRK 650R OB	
ART44-4	RF-44,000	Before 2008	FDRK 650F OB	69
	RF-44,000	After 2008	FDRK 650FA OB	
	RR-44,000		FDRK 650R OB	
Dana				
S14-110	R-14,500		FDRK 434 OB	66
S14-111	R-14,500		FDRK 434 OB	66
S16-130	R-16,500		FDRK 434 OB	66
S16-132	R-16,500		FDRK 434 OB	66
S17-140	R-17,000		FDRK 452 OB	68
S19-140	R-19,000		FDRK 452 OB	68
S21-170	R-21,000	Before 6-10-13 and w/2.69-3.91 Ratios	FDRK 438A OB	66
	R-21,000	Before 6-10-13 and w/4.10-7.17 Ratios	FDRK 439A OB	67
	R-21,000	After 6-9-13 and w/2.69-3.91 Ratios	FDRK 438 OB	66
	R-21,000	After 6-9-13 and w/4.10-7.17 Ratios	FDRK 439 OB	66
S21-170D	R-21,000	Before 6-10-13 and w/2.69-3.91 Ratios	FDRK 443A OB	67
	R-21,000	Before 6-10-13 and w/4.10-7.17 Ratios	FDRK 444A OB	67
	R-21,000	After 6-9-13 and w/2.69-3.91 Ratios	FDRK 443 OB	67
	R-21,000	After 6-9-13 and w/4.10-7.17 Ratios	FDRK 444 OB	67
S21-170DE	R-21,000	Before 6-10-13	FDRK 454 OB	68
	R-21,000	After 6-9-13	FDRK 454A OB	68
S21-170D	R-21,000	Before 6-10-13	FDRK 454 OB	68
	R-21,000	After 6-9-13	FDRK 454A OB	68
S23-170	R-23,000	Before 6-10-13 and w/2.69-3.91 Ratios	FDRK 438A OB	66
	R-23,000	Before 6-10-13 and w/4.10-7.17 Ratios	FDRK 439A OB	67
	R-23,000	After 6-9-13 and w/2.69-3.91 Ratios	FDRK 438 OB	66
	R-23,000	After 6-9-13 and w/4.10-7.17 Ratios	FDRK 439 OB	66
S23-170D	R-23,000	Before 6-10-13 and w/2.69-3.91 Ratios	FDRK 443A OB	67
	R-23,000	Before 6-10-13 and w/4.10-7.17 Ratios	FDRK 444A OB	67
	R-23,000	After 6-9-13 and w/2.69-3.91 Ratios	FDRK 443 OB	67
	R-23,000	After 6-9-13 and w/4.10-7.17 Ratios	FDRK 444 OB	67
S23-170DE	R-23,000	Before 6-10-13	FDRK 454 OB	68
	R-23,000	After 6-9-13	FDRK 454A OB	68
S23-170E	R-23,000	Before 6-10-13	FDRK 454 OB	68
	R-23,000	After 6-9-13	FDRK 454A OB	68
S25-170	R-25,000	Before 6-10-13 and w/2.69-3.91 Ratios	FDRK 438 OB	66
	R-25,000	Before 6-10-13 and w/4.10-7.17 Ratios	FDRK 439 OB	66
	R-25,000	After 6-9-13 and w/2.69-3.91 Ratios	FDRK 438A OB	66
	R-25,000	After 6-10-13 and w/4.10-7.17 Ratios	FDRK 439A OB	67

Axle Model	Type/Cap.	Notes	Fersa Bearing Kit	Pg.
Dana				
S25-170D	R-25,000	Before 6-10-13 and w/2.69-3.91 Ratios	FDRK 443 OB	67
	R-25,000	Before 6-10-13 and w/4.10-7.17 Ratios	FDRK 444 OB	67
	R-25,000	After 6-9-13 and w/2.69-3.91 Ratios	FDRK 443A OB	67
	R-25,000	After 6-10-13 and w/4.10-7.17 Ratios	FDRK 444A OB	67
S25-170DE	R-25,000	Before 6-10-13	FDRK 454 OB	68
	R-25,000	After 6-9-13	FDRK 454A OB	68
S25-170E	R-25,000	Before 6-10-13	FDRK 454 OB	68
	R-25,000	After 6-9-13	FDRK 454A OB	68
S21-190	R-21,000	Before 6-10-13 and w/2.53-4.78 Ratios	FDRK 443 OB	67
	R-21,000	Before 6-10-13 and w/5.25-7.83 Ratios	FDRK 441 OB	67
	R-21,000	After 6-10-13 and w/2.53-4.78 Ratios	FDRK 443A OB	67
	R-21,000	After 6-10-13 and w/5.25-7.83 Ratios	FDRK 441A OB	67
S21-190D	R-21,000	Before 6-10-13 and w/2.53-4.78 Ratios	FDRK 443 OB	67
	R-21,000	Before 6-10-13 and w/5.25-7.83 Ratios	FDRK 441 OB	67
	R-21,000	After 6-10-13 and w/2.53-4.78 Ratios	FDRK 443A OB	67
	R-21,000	After 6-10-13 and w/5.25-7.83 Ratios	FDRK 441A OB	67
S23-190	R-23,000	Before 6-10-13 and w/2.53-4.78 Ratios	FDRK 443 OB	67
	R-23,000	Before 6-10-13 and w/5.25-7.83 Ratios	FDRK 441 OB	67
	R-23,000	After 6-10-13 and w/2.53-4.78 Ratios	FDRK 443A OB	67
	R-23,000	After 6-10-13 and w/5.25-7.83 Ratios	FDRK 441A OB	67
S23-190D	R-23,000	Before 6-10-13 and w/2.53-4.78 Ratios	FDRK 443 OB	67
	R-23,000	Before 6-10-13 and w/5.25-7.83 Ratios	FDRK 441 OB	67
	R-23,000	After 6-10-13 and w/2.53-4.78 Ratios	FDRK 443A OB	67
	R-23,000	After 6-10-13 and w/5.25-7.83 Ratios	FDRK 441A OB	67
S23-190DE	R-23,000	Before 6-10-13	FDRK 453 OB	68
	R-23,000	After 6-9-13	FDRK 453A OB	68
S23-190E	R-23,000	Before 6-10-13	FDRK 453 OB	68
	R-23,000	After 6-9-13	FDRK 453A OB	68
S26-190	R-26,000	Before 6-10-13 and w/2.53-4.78 Ratios	FDRK 443 OB	67
	R-26,000	Before 6-10-13 and w/5.25-7.83 Ratios	FDRK 441 OB	67
	R-26,000	After 6-10-13 and w/2.53-4.78 Ratios	FDRK 443A OB	67
	R-26,000	After 6-10-13 and w/5.25-7.83 Ratios	FDRK 441A OB	67
S26-190D	R-26,000	Before 6-10-13 and w/2.53-4.78 Ratios	FDRK 443 OB	67
	R-26,000	Before 6-10-13 and w/5.25-7.83 Ratios	FDRK 441 OB	67
	R-26,000	After 6-10-13 and w/2.53-4.78 Ratios	FDRK 443A OB	67
	R-26,000	After 6-10-13 and w/5.25-7.83 Ratios	FDRK 441A OB	67
S26-190DE	R-26,000	Before 6-10-13	FDRK 453 OB	68
	R-26,000	After 6-9-13	FDRK 453A OB	68
S26-190E	R-26,000	Before 6-10-13	FDRK 453 OB	68
	R-26,000	After 6-9-13	FDRK 453A OB	68
S30-190	R-30,000	Before 6-10-13 and w/2.53-4.78 Ratios	FDRK 443 OB	67
	R-30,000	Before 6-10-13 and w/5.25-7.83 Ratios	FDRK 441 OB	67
	R-30,000	After 6-9-13 and w/2.53-4.78 Ratios	FDRK 443A OB	67
	R-30,000	After 6-9-13 and w/5.25-7.83 Ratios	FDRK 441A OB	67
S30-190D	R-30,000	Before 6-10-13 and w/2.53-4.78 Ratios	FDRK 443 OB	67
	R-30,000	Before 6-10-13 and w/5.25-7.83 Ratios	FDRK 441 OB	67
	R-30,000	After 6-9-13 and w/2.53-4.78 Ratios	FDRK 443A OB	67
	R-30,000	After 6-9-13 and w/5.25-7.83 Ratios	FDRK 441A OB	67
S30-190DE	R-30,000	Before 6-10-13	FDRK 453 OB	68
	R-30,000	After 6-9-13	FDRK 453A OB	68
S30-190E	R-30,000	Before 6-10-13	FDRK 453 OB	68
	R-30,000	After 6-9-13	FDRK 453A OB	68
S23-590	R-23,000	Before 6-10-13	FDRK 453 OB	68
	R-23,000	After 6-9-13	FDRK 453A OB	68

1.1 \

Heavy Duty Differential Index

Axle Model	Type/Cap.	Notes	Fersa Bearing Kit	Pg.
Dana				
S23-590D	R-23,000	Before 6-10-13	FDRK 453 OB	68
	R-23,000	After 6-9-13	FDRK 453A OB	68
S26-590	R-26,000	Before 6-10-13	FDRK 453 OB	68
	R-26,000	After 6-9-13	FDRK 453A OB	68
S26-590D	R-26,000	Before 6-10-13	FDRK 453 OB	68
	R-26,000	After 6-9-13	FDRK 453A OB	68
S30-590	R-30,000	Before 6-10-13	FDRK 453 OB	68
	R-30,000	After 6-9-13	FDRK 453A OB	68
S30-590D	R-30,000	Before 6-10-13	FDRK 453 OB	68
	R-30,000	After 6-9-13	FDRK 453A OB	68
S35-590	R-35,000	Before 6-10-13	FDRK 453 OB	68
	R-35,000	After 6-9-13	FDRK 453A OB	68
S35-590D	R-35,000	Before 6-10-13	FDRK 453 OB	68
	R-35,000	After 6-9-13	FDRK 453A OB	68
D40-145S	F-40,000		FDRK 427A OB	65
D40-145X	F-40,000		FDRK 427A OB	65
R40-145S	R-40,000		FDRK 452 OB	68
D40-170	F-40,000	Before 6-10-13	FDRK 442 OB	67
	F-40,000	After 6-9-13	FDRK 442A OB	67
D40-170D	F-40,000	Before 6-10-13	FDRK 436 OB	66
	F-40,000	After 6-9-13	FDRK 436A OB	66
D40-170DP	F-40,000	Before 6-10-13	FDRK 436 OB	66
	F-40,000	After 6-9-13	FDRK 436A OB	66
D50-170D	F-50,000	Before 6-10-13	FDRK 436 OB	66
	F-50,000	After 6-9-13	FDRK 436A OB	66
D50-170DP	F-50,000	Before 6-10-13	FDRK 436 OB	66
	F-50,000	After 6-9-13	FDRK 436A OB	66
D50-170P	F-50,000	Before 6-10-13	FDRK 442 OB	67
	F-50,000	After 6-9-13	FDRK 442A OB	67
R50-170	F-50,000	Before 6-10-13 and w/2.69-3.91 Ratios	FDRK 438 OB	66
	F-50,000	Before 6-10-13 and w/4.10-7.17 Ratios	FDRK 439 OB	66
	F-50,000	After 6-9-13 and w/2.69-3.91 Ratios	FDRK 438A OB	66
	F-50,000	After 6-9-13 and w/4.10-7.17 Ratios	FDRK 439A OB	67
R50-170D	R-50,000	Before 6-10-13 and w/2.69-3.91 Ratios	FDRK 443 OB	67
	R-50,000	Before 6-10-13 and w/4.10-7.17 Ratios	FDRK 444 OB	67
	R-50,000	After 6-9-13 and w/2.69-3.91 Ratios	FDRK 443A OB	67
	R-50,000	After 6-9-13 and w/4.10-7.17 Ratios	FDRK 444A OB	67
D40-170P	F-40,000	Before 6-10-13	FDRK 442 OB	67
	F-40,000	After 6-9-13	FDRK 442A OB	67
R40-170	R-40,000	Before 6-10-13 and w/2.69-3.91 Ratios	FDRK 438 OB	66
	R-40,000	Before 6-10-13 and w/4.10-7.17 Ratios	FDRK 439 OB	66
	R-40,000	After 6-9-13 and w/2.69-3.91 Ratios	FDRK 438A OB	66
	R-40,000	After 6-9-13 and w/4.10-7.17 Ratios	FDRK 439A OB	67
R40-170D	R-40,000	Before 6-10-13 and w/2.69-3.91 Ratios	FDRK 443A OB	67
	R-40,000	Before 6-10-13 and w/4.10-7.17 Ratios	FDRK 444A OB	67
	R-40,000	After 6-9-13 and w/2.69-3.91 Ratios	FDRK 443 OB	67
	R-40,000	After 6-9-13 and w/4.10-7.17 Ratios	FDRK 444 OB	67
D46-170	F-46,000	Before 6-10-13	FDRK 442 OB	67
	F-46,000	After 6-9-13	FDRK 442A OB	67
D46-170D	F-46,000	Before 6-10-13	FDRK 436 OB	66
	F-46,000	After 6-9-13	FDRK 436A OB	66

Axle Model	Type/Cap.	Notes	Fersa Bearing Kit	Pg.
Dana				
D46-170DP	F-46,000	Before 6-10-13	FDRK 436 OB	66
	F-46,000	After 6-9-13	FDRK 436A OB	66
D46-170H	F-46,000	Before 6-10-13	FDRK 442 OB	67
	F-46,000	After 6-9-13	FDRK 442A OB	67
D46-170HP	F-46,000	Before 6-10-13	FDRK 442 OB	67
	F-46,000	After 6-9-13	FDRK 442A OB	67
D46-170P	F-46,000	Before 6-10-13	FDRK 442 OB	67
	F-46,000	After 6-9-13	FDRK 442A OB	67
R46-170	R-46,000	Before 6-10-13 and w/2.69-3.91 Ratios	FDRK 438 OB	66
	R-46,000	Before 6-10-13 and w/4.10-7.17 Ratios	FDRK 439 OB	66
	R-46,000	After 6-9-13 and w/2.69-3.91 Ratios	FDRK 438A OB	66
	R-46,000	After 6-9-13 and w/4.10-7.17 Ratios	FDRK 439A OB	67
R46-170D	R-46,000	Before 6-10-13 and w/2.69-3.91 Ratios	FDRK 443 OB	67
	R-46,000	Before 6-10-13 and w/4.10-7.17 Ratios	FDRK 444 OB	67
	R-46,000	After 6-9-13 and w/2.69-3.91 Ratios	FDRK 443A OB	67
	R-46,000	After 6-9-13 and w/4.10-7.17 Ratios	FDRK 444A OB	67
D50-170	F-50,000	Before 6-10-13	FDRK 442 OB	67
	F-50,000	After 6-9-13	FDRK 442A OB	67
D52-190DP	F-52,000	After 6-9-13	FDRK 437 OB	66
	F-52,000	Before 6-10-13	FDRK 437A OB	66
D52-190P	F-52,000	After 6-9-13	FDRK 437 OB	66
	F-52,000	Before 6-10-13	FDRK 437A OB	66
R52-190	R-52,000	Before 6-10-13 and w/2.53-4.78 Ratios	FDRK 443 OB	67
	R-52,000	Before 6-10-13 and w/5.25-7.83 Ratios	FDRK 441 OB	67
	R-52,000	After 6-9-13 and w/2.53-4.78 Ratios	FDRK 443A OB	67
	R-52,000	After 6-9-13 and w/5.25-7.83 Ratios	FDRK 441A OB	67
R52-190D	R-52,000	Before 6-10-13 and w/2.53-4.78 Ratios	FDRK 443 OB	67
	R-52,000	Before 6-10-13 and w/5.25-7.83 Ratios	FDRK 441 OB	67
	R-52,000	After 6-9-13 and w/2.53-4.78 Ratios	FDRK 443A OB	67
	R-52,000	After 6-9-13 and w/5.25-7.83 Ratios	FDRK 441A OB	67
D60-190DP	F-60,000	After 6-9-13	FDRK 437 OB	66
	F-60,000	Before 6-10-13	FDRK 437A OB	66
D60-190P	F-60,000	After 6-9-13	FDRK 437 OB	66
	F-60,000	Before 6-10-13	FDRK 437A OB	66
R60-190	R-60,000	Before 6-10-13 and w/2.53-4.78 Ratios	FDRK 443 OB	67
	R-60,000	Before 6-10-13 and w/5.25-7.83 Ratios	FDRK 441 OB	67
	R-60,000	After 6-9-13 and w/2.53-4.78 Ratios	FDRK 443A OB	67
	R-60,000	After 6-9-13 and w/5.25-7.83 Ratios	FDRK 441A OB	67
R60-190D	R-60,000	Before 6-10-13 and w/2.53-4.78 Ratios	FDRK 443 OB	67
	R-60,000	Before 6-10-13 and w/5.25-7.83 Ratios	FDRK 441 OB	67
	R-60,000	After 6-9-13 and w/2.53-4.78 Ratios	FDRK 443A OB	67
	R-60,000	After 6-9-13 and w/5.25-7.83 Ratios	FDRK 441A OB	67
D46-590DHP	F-46,000	Before 6-10-13	FDRK 437 OB	66
	F-46,000	After 6-9-13	FDRK 437A OB	66
D46-590HP	F-46,000	Before 6-10-13	FDRK 437 OB	66
	F-46,000	After 6-9-13	FDRK 437A OB	66
R46-590	R-46,000	Before 6-10-13	FDRK 453 OB	68
	R-46,000	After 6-9-13	FDRK 453A OB	68
R46-590D	R-46,000	Before 6-10-13	FDRK 453 OB	68
	R-46,000	After 6-9-13	FDRK 453A OB	68
D52-590DP	F-52,000	Before 6-10-13	FDRK 437 OB	66
	F-52,000	After 6-9-13	FDRK 437A OB	66
D52-590P	F-52,000	Before 6-10-13	FDRK 437 OB	66
	F-52,000	After 6-9-13	FDRK 437A OB	66

1.1 \

Heavy Duty Differential Index

Axle Model	Type/Cap.	Notes	Fersa Bearing Kit	Pg.
Dana				
R52-590	R-52,000	Before 6-10-13	FDRK 453 OB	68
	R-52,000	After 6-9-13	FDRK 453A OB	68
R52-590D	R-52,000	Before 6-10-13	FDRK 453 OB	68
	R-52,000	After 6-9-13	FDRK 453A OB	68
D60-590DP	F-60,000	Before 6-10-13	FDRK 437 OB	66
	F-60,000	After 6-9-13	FDRK 437A OB	66
D60-590P	F-60,000	Before 6-10-13	FDRK 437 OB	66
	F-60,000	After 6-9-13	FDRK 437A OB	66
R60-590	R-60,000	Before 6-10-13	FDRK 453 OB	68
	R-60,000	After 6-9-13	FDRK 453A OB	68
R60-590D	R-60,000	Before 6-10-13	FDRK 453 OB	68
	R-60,000	After 6-9-13	FDRK 453A OB	68
D70-590DP	F-70,000	Before 6-10-13	FDRK 437 OB	66
	F-70,000	After 6-9-13	FDRK 437A OB	66
D70-590P	F-70,000	Before 6-10-13	FDRK 437 OB	66
	F-70,000	After 6-9-13	FDRK 437A OB	66
R70-590	R-70,000	Before 6-10-13	FDRK 453 OB	68
	R-70,000	After 6-9-13	FDRK 453A OB	68
R70-590D	R-70,000	Before 6-10-13	FDRK 453 OB	68
	R-70,000	After 6-9-13	FDRK 453A OB	68
S135-S	R-13,500		FDRK 414 OB	63
S150-S	R-15,500		FDRK 414 OB	63
F155-S	R-15,500		FDRK 191R OB	56
G155-T	R-15,500		FDRK 213 OB	60
G160-D	R-16,000		FDRK 213 OB	60
G160-T	R-16,000		FDRK 213 OB	60
F170-S	R-17,000		FDRK 191R OB	56
F175-D	R-17,500		FDRK 213 OB	60
G175-R	R-17,500		FDRK 213 OB	60
G175-T	R-17,500		FDRK 213 OB	60
J175-S	R-17,500		FDRK 192RB OB	57
N175	R-17,500		FDRK 223R OB	61
G185-S	R-18,500		FDRK 213 OB	60
M185-D	R-18,500		FDRK 214 OB	60
M185-T	R-18,500		FDRK 214 OB	60
G190-S	R-19,000		FDRK 213 OB	60
J190-S	R-19,000		FDRK 192RB OB	57
M190-T	R-19,000		FDRK 214 OB	60
N190	R-19,000		FDRK 223R OB	61
M200-D	R-20,000		FDRK 214 OB	60
M200-T	R-20,000		FDRK 214 OB	60
J210-S	R-21,000		FDRK 192RB OB	57
M210-T	R-21,000		FDRK 214 OB	60
J220-S	R-22,000		FDRK 192RB OB	57
M220-D	R-22,000		FDRK 214 OB	60
M220-T	R-22,000		FDRK 214 OB	60
J230-S	R-23,000		FDRK 192RB OB	57
J230-SB	R-23,000		FDRK 192RB OB	57
M230-T	R-23,000		FDRK 214 OB	60
S230-S	R-23,000		FDRK 416 OB	63
S230-SB	R-23,000		FDRK 416 OB	63
S230-SL	R-23,000		FDRK 416 OB	63
W230-S	R-23,000		FDRK 201R OB	58

Axle Model	Type/Cap.	Notes	Fersa Bearing Kit	Pg.
Dana				
S260-SB	R-26,000		FDRK 416 OB	63
G340-S	F-34,000		FDRK 192FB OB	57
J340-S	F-34,000		FDRK 200FA OB	58
	R-34,000		FDRK 192RB OB	57
N340-S	F-34,000		FDRK 223F OB	61
	R-34,000		FDRK 223R OB	61
G380-S	F-38,000		FDRK 192FB OB	57
J380-S	F-38,000		FDRK 200FA OB	58
	R-38,000		FDRK 192RB OB	57
J400-S	F-40,000		FDRK 200FA OB	58
	R-40,000		FDRK 192RB OB	57
N400-I	F-40,000		FDRK 223F OB	61
	R-40,000		FDRK 223R OB	61
S400-S	F-40,000		FDRK 411F OB	63
	R-40,000		FDRK 411R OB	63
W440-S	F-44,000		FDRK 201FA OB	58
	R-44,000		FDRK 201R OB	58
W460-S	F-46,000		FDRK 201FA OB	58
	R-46,000		FDRK 201R OB	58

Eaton				
30R3	R-30,000		FDRK 23 OB	54
30RP	R-30,000		FDRK 23 OB	54
30RS	R-30,000	w/ Conical Carrier	FDRK 23B OB	54
	R-30,000	w/ Ribbed Carrier	FDRK 23 OB	54
30RT	R-30,000		FDRK 23 OB	54
34D3	F-34,000	w/ Ball On Input Shaft	FDRK 64F OB	55
	F-34,000	w/ Taper On Input Shaft	FDRK 64FE OB	55
34DP	F-34,000	w/ Ball On Input Shaft	FDRK 64F OB	55
	F-34,000	w/ Taper On Input Shaft	FDRK 64FE OB	55
34DS	F-34,000	w/ Conical Carrier & Ball On Input Shaft	FDRK 64FC OB	55
	F-34,000	w/ Conical Carrier & Taper On Input Shaft	FDRK 64FD OB	55
	F-34,000	w/ Ribbed Carrier & Ball On Input Shaft	FDRK 64F OB	55
	F-34,000	w/ Ribbed Carrier & Taper On Input Shaft	FDRK 64FE OB	55
34DT	F-34,000	w/ Ball On Input Shaft	FDRK 64F OB	55
	F-34,000	w/ Taper On Input Shaft	FDRK 64FE OB	55
34R3	R-34,000		FDRK 1 OB	54
34RP	R-34,000	w/ Conical Carrier	FDRK 1A OB	54
	R-34,000	w/ Ribbed Carrier	FDRK 1 OB	54
34RS	R-34,000	w/ Conical Carrier	FDRK 1A OB	54
34RSB	R-34,000		FDRK 1A OB	54
34RT	R-34,000		FDRK 1 OB	54
38D3	F-38,000	w/ Ball On Input Shaft	FDRK 64F OB	55
	F-38,000	w/ Taper On Input Shaft	FDRK 64FE OB	55
38DP	F-38,000	w/ Ball On Input Shaft	FDRK 64F OB	55
	F-38,000	w/ Taper On Input Shaft	FDRK 64FE OB	55
38DS	F-38,000	w/ Conical Carrier & Ball On Input Shaft	FDRK 64FC OB	55
	F-38,000	w/ Conical Carrier & Taper On Input Shaft	FDRK 64FD OB	55
	F-38,000	w/ Ribbed Carrier & Ball On Input Shaft	FDRK 64F OB	55
	F-38,000	w/ Ribbed Carrier & Taper On Input Shaft	FDRK 64FE OB	55
38DT	F-38,000	w/ Ball On Input Shaft	FDRK 64F OB	55
	F-38,000	w/ Taper On Input Shaft	FDRK 64FE OB	55

1.1 \

Heavy Duty Differential Index

Axle Model	Type/Cap.	Notes	Fersa Bearing Kit	Pg.
Eaton				
38R3	R-38,000		FDRK 1 OB	54
38RP	R-38,000	w/ Conical Carrier	FDRK 1A OB	54
	R-38,000	w/ Ribbed Carrier	FDRK 1 OB	54
38RS	R-38,000		FDRK 1A OB	54
38RSB	R-38,000		FDRK 1A OB	54
38RT	R-38,000		FDRK 1 OB	54
DDH40(P)	F-40,000	After 6/16/08	FDRK 428A OB	65
	F-40,000	Before 6/16/08	FDRK 428 OB	65
DDP40(P)	F-40,000	After 6/16/08	FDRK 428A OB	65
	F-40,000	Before 6/16/08	FDRK 428 OB	65
DDS40(P)	F-40,000		FDRK 435 OB	66
DDT40-P	F-40,000	After 6/16/08	FDRK 405FA OB	62
	F-40,000	Before 6/16/08	FDRK 405F OB	62
DSH40(P)	F-40,000	After 6/16/08	FDRK 427A OB	65
	F-40,000	Before 6/16/08	FDRK 427 OB	65
DSP40(P)	F-40,000	After 6/16/08	FDRK 427A OB	65
	F-40,000	Before 6/16/08	FDRK 427 OB	65
DSS40(P)	F-40,000		FDRK 431 OB	65
DST40(P)	F-40,000	After 6/16/08	FDRK 404FA OB	62
	F-40,000	Before 6/16/08	FDRK 404F OB	61
RDH40	R-40,000		FDRK 430 OB	65
RDP40	R-40,000		FDRK 430 OB	65
RDS40	R-40,000		FDRK 219R OB	60
RDT40	R-40,000		FDRK 445 OB	67
RSH40	R-40,000		FDRK 429 OB	65
RSP40	R-40,000		FDRK 429 OB	65
RSS40	R-40,000		FDRK 449 OB	68
RST40	R-40,000	After 4/1/05 & 2.64-5.57 Ratios	FDRK 447 OB	67
	R-40,000	After 4/1/05 & 6.17-7.17 Ratios	FDRK 448 OB	68
	R-40,000	Before 4/1/05 & 2.64-5.57 Ratios	FDRK 445 OB	67
	R-40,000	Before 4/1/05 & 6.17-7.17 Ratios	FDRK 446 OB	67
DDP41(P)	F-41,000	After 6/16/08	FDRK 428A OB	65
	F-41,000	Before 6/16/08	FDRK 428 OB	65
DDS41(P)	F-41,000		FDRK 435 OB	66
DDT41(P)	F-41,000	After 6/16/08	FDRK 405FA OB	62
	F-41,000	Before 6/16/08	FDRK 405F OB	62
DSP41(P)	F-41,000	After 6/16/08	FDRK 427A OB	65
	F-41,000	Before 6/16/08	FDRK 427 OB	65
DST41(P)	F-41,000	After 6/16/08	FDRK 404FA OB	62
	F-41,000	Before 6/16/08	FDRK 404F OB	61
RDP41	R-41,000		FDRK 430 OB	65
RDT41	R-41,000		FDRK 445 OB	67
RSP41	R-41,000		FDRK 429 OB	65
RST41	R-41,000	After 4/1/05 & 2.64-5.57 Ratios	FDRK 447 OB	67
	R-41,000	After 4/1/05 & 6.17-7.17 Ratios	FDRK 448 OB	68
	R-41,000	Before 4/1/05 & 2.64-5.57 Ratios	FDRK 445 OB	67
	R-41,000	Before 4/1/05 & 6.17-7.17 Ratios	FDRK 446 OB	67
42D3	F-42,000	w/ Ball On Input Shaft	FDRK 64F OB	55
	F-42,000	w/ Taper On Input Shaft	FDRK 64FE OB	55
42DP	F-42,000	w/ Ball On Input Shaft	FDRK 64F OB	55
	F-42,000	w/ Taper On Input Shaft	FDRK 64FE OB	55
42DT	F-42,000	w/ Ball On Input Shaft	FDRK 64F OB	55
	F-42,000	w/ Taper On Input Shaft	FDRK 64FE OB	55

Axle Model	Type/Cap.	Notes	Fersa Bearing Kit	Pg.
Eaton				
42R3	R-42,000		FDRK 1 OB	54
42RP	R-42,000		FDRK 1 OB	54
42RS	R-42,000		FDRK 18D OB	54
42RT	R-42,000		FDRK 1 OB	54
44DP	F-44,000		FDRK 209A OB	59
44DS	F-44,000		FDRK 208A OB	59
44DSM	F-44,000		FDRK 208A OB	59
44DT	F-44,000		FDRK 72A OB	55
	F-44,000		FDRK 209A OB	59
44RPB	R-44,000		FDRK 72A OB	55
44RS	R-44,000	w/ Casting # C67854 / Bef. 2-1-79	FDRK 413 OB	63
	R-44,000	w/ Casting # C98493 / Aft. 2-1-79	FDRK 219R OB	60
44RSB	R-44,000	w/ Large Spherical Diff	FDRK 18E OB	54
44RSM	R-44,000		FDRK 413 OB	63
44RT	R-44,000	w/ 103537 Case	FDRK 72B OB	55
	R-44,000	w/o 103537 Case	FDRK 72A OB	55
44RTB	R-44,000		FDRK 72A OB	55
DDH44(P)	F-44,000		FDRK 427 OB	65
DSH44(P)	F-44,000		FDRK 428 OB	65
RDH44	R-44,000		FDRK 429 OB	65
RSH44	R-44,000		FDRK 429 OB	65
50DP	F-50,000		FDRK 193 OB	57
50DT	F-50,000		FDRK 193 OB	57
50RP	R-50,000		FDRK 1 OB	54
50RT	R-50,000		FDRK 1 OB	54
190C4	R-19,000		FDRK 419 OB	64
190P4	R-19,000		FDRK 419 OB	64
190S4	R-19,000		FDRK 417 OB	63
190T4	R-19,000		FDRK 419 OB	64
220C4	R-22,000		FDRK 419 OB	64
220P4	R-22,000		FDRK 419 OB	64
220S4	R-22,000		FDRK 417 OB	63
220T4	R-22,000		FDRK 419 OB	64
230C4	R-23,000		FDRK 420 OB	64
230P4	R-23,000		FDRK 421 OB	64
230S4	R-23,000		FDRK 418 OB	64
230T4	R-23,000		FDRK 421 OB	64
260C4	R-26,000		FDRK 420 OB	64
260P4	R-26,000		FDRK 421 OB	64
260S4	R-26,000		FDRK 418 OB	64
260T4	R-26,000		FDRK 421 OB	64
300C4	R-30,000		FDRK 420 OB	64
300P4	R-30,000		FDRK 420 OB	64
300S4	R-30,000		FDRK 418 OB	64
300T4	R-30,000		FDRK 421 OB	64
DP340	F-34,000		FDRK 193 OB	57
DS340	F-34,000	1-Speed Carrier / Aft. 4-30-78	FDRK 193A OB	57
	F-34,000	2-Speed Carrier / Bef. 4-30-78	FDRK 193 OB	57
DT340	F-34,000		FDRK 193 OB	57
RP340	R-34,000		FDRK 1 OB	54
RS340	R-34,000	1-Speed Carrier / Aft. 4-30-78	FDRK 1A OB	54
	R-34,000	2-Speed Carrier / Bef. 4-30-78	FDRK 1 OB	54
RT340	R-34,000		FDRK 1 OB	54

1.1 \

Heavy Duty Differential Index

Axle Model	Type/Cap.	Notes	Fersa Bearing Kit	Pg.
Eaton				
DC341(P)	F-34,000		FDRK 207 OB	59
DP341(P)	F-34,000		FDRK 207 OB	59
DS341(P)	F-34,000	4-6-89 thru 12-31-94	FDRK 222F OB	61
	F-34,000	After 1-1-95	FDRK 196 OB	58
	F-34,000	Before 4-6-89	FDRK 196 OB	58
DT341(P)	F-34,000		FDRK 207 OB	59
RC341	R-34,000		FDRK 1 OB	54
RP341	R-34,000		FDRK 1 OB	54
RS341	R-34,000	4-6-89 thru 12-31-94	FDRK 222R OB	61
	R-34,000	After 1-1-95	FDRK 412 OB	63
	R-34,000	Before 4-6-89	FDRK 1A OB	54
RT341	R-34,000		FDRK 1 OB	54
DA344	F-34,000		FDRK 404F OB	61
DS344	F-34,000	After 6/16/08	FDRK 404FA OB	62
	F-34,000	Before 6/16/08	FDRK 404F OB	61
RA344	R-34,000		FDRK 404R OB	62
RS344	R-34,000		FDRK 404R OB	62
350C4	R-35,000		FDRK 420 OB	64
	R-35,000		FDRK 420 OB	64
350S4	R-35,000		FDRK 418 OB	64
350T4	R-35,000		FDRK 420 OB	64
DP380-P	F-38,000		FDRK 193 OB	57
DS380(P)	F-38,000	1-Speed Carrier / Aft 4-30-78	FDRK 193A OB	57
	F-38,000	2-Speed Carrier / Bef 4-30-78	FDRK 193 OB	57
DT380(P)	F-38,000		FDRK 193 OB	57
RP380(P)	R-38,000		FDRK 1 OB	54
RS380	R-38,000	1-Speed Carrier / Aft 4-30-78	FDRK 1A OB	54
	R-38,000	2-Speed Carrier / Bef 4-30-78	FDRK 1 OB	54
RT380(P)	R-38,000		FDRK 1 OB	54
DC381(P)	F-38,000		FDRK 207 OB	59
DP381(P)	F-38,000		FDRK 207 OB	59
DS381(P)	F-38,000		FDRK 196 OB	58
DT381(P)	F-38,000		FDRK 207 OB	59
RC381	R-38,000		FDRK 1 OB	54
RP381(P)	R-38,000		FDRK 1 OB	54
RS381	R-38,000		FDRK 1A OB	54
RT381(P)	R-38,000		FDRK 1 OB	54
DS385	F-38,000		FDRK 1 OB	54
DC386-P	F-38,000		FDRK 424 OB	64
DP386-P	F-38,000		FDRK 424 OB	64
DS386-P	F-38,000		FDRK 422 OB	64
DT386-P	F-38,000		FDRK 424 OB	64
RC386	R-38,000		FDRK 1 OB	54
RP386-P	R-38,000		FDRK 1 OB	54
RS386	R-38,000		FDRK 1A OB	54
RT386-P	R-38,000		FDRK 1 OB	54
DP400(P)	F-40,000		FDRK 193 OB	57
DS400-P	F-40,000	1-Speed Carrier / Aft 4-30-78	FDRK 193A OB	57
	F-40,000	2-Speed Carrier / Bef 4-30-78	FDRK 193 OB	57
DT400(P)	F-40,000		FDRK 193 OB	57
RP400(P)	R-40,000		FDRK 1 OB	54
RS400	R-40,000	1-Speed Carrier / Aft 4-30-78	FDRK 1A OB	54
	R-40,000	2-Speed Carrier / Bef 4-30-78	FDRK 1 OB	54

Axle Model	Type/Cap.	Notes	Fersa Bearing Kit	Pg.
Eaton				
RT400(P)	R-40,000		FDRK 1 OB	54
DC401-P	F-40,000		FDRK 207 OB	59
DP401(P)	F-40,000		FDRK 207 OB	59
DS401-P	F-40,000		FDRK 196 OB	58
DT401(P)	F-40,000		FDRK 207 OB	59
RC401	R-40,000		FDRK 1 OB	54
RP401(P)	R-40,000		FDRK 1 OB	54
RS401	R-40,000		FDRK 1A OB	54
RT401(P)	R-40,000		FDRK 1 OB	54
DA402(P)	F-40,000	4-6-89 thru 12-31-94	FDRK 222F OB	61
	F-40,000	After 1-1-95	FDRK 196 OB	58
DC402(P)	F-40,000		FDRK 207 OB	59
DP402(P)	F-40,000		FDRK 207 OB	59
DS402(P)	F-40,000	4-6-89 thru 12-31-94	FDRK 222F OB	61
	F-40,000	After 1-1-95	FDRK 196 OB	58
	F-40,000	Before 4-6-89	FDRK 196 OB	58
DT402(P)	F-40,000		FDRK 207 OB	59
RA402	R-40,000	4-6-89 thru 12-31-94	FDRK 222R OB	61
	R-40,000	After 1-1-95	FDRK 412 OB	63
RC402	R-40,000		FDRK 1 OB	54
RP402(P)	R-40,000		FDRK 1 OB	54
RS402	R-40,000	4-6-89 thru 12-31-94	FDRK 222R OB	61
	R-40,000	After 1-1-95	FDRK 412 OB	63
	R-40,000	Before 4-6-89	FDRK 1A OB	54
RT402(P)	R-40,000		FDRK 1 OB	54
DS403(P)	F-40,000	4-6-89 thru 12-31-94	FDRK 222F OB	61
	F-40,000	After 1-1-95	FDRK 196 OB	58
	F-40,000	Before 4-6-89	FDRK 196 OB	58
RS403	R-40,000	4-6-89 thru 12-31-94	FDRK 222R OB	61
	R-40,000	After 1-1-95	FDRK 412 OB	63
	R-40,000	Before 4-6-89	FDRK 1A OB	54
DA404(P)	F-40,000	After 6/16/08	FDRK 404FA OB	62
	F-40,000	Before 6/16/08	FDRK 404F OB	61
DD404(P)	F-40,000	After 6/16/08	FDRK 405FA OB	62
	F-40,000	Before 6/16/08	FDRK 405F OB	62
DS404(P)	F-40,000	After 6/16/08	FDRK 404FA OB	62
	F-40,000	Before 6/16/08	FDRK 404F OB	61
RA404	R-40,000		FDRK 404R OB	62
RD404	R-40,000		FDRK 405R OB	62
RS404	R-40,000		FDRK 404R OB	62
DA405(P)	F-40,000	After 6/16/08	FDRK 404FA OB	62
	F-40,000	Before 6/16/08	FDRK 404F OB	61
DD405(P)	F-40,000	After 6/16/08	FDRK 405FA OB	62
	F-40,000	Before 6/16/08	FDRK 405F OB	62
DS405(P)	F-40,000	After 6/16/08	FDRK 404FA OB	62
	F-40,000	Before 6/16/08	FDRK 404F OB	61
RA405	R-40,000		FDRK 404R OB	62
RD405	R-40,000		FDRK 405R OB	62
RS405	R-40,000		FDRK 404R OB	62
DC406-P	F-40,000		FDRK 424 OB	64
DP406-P	F-40,000		FDRK 424 OB	64
DS406-P	F-40,000		FDRK 422 OB	64
DT406-P	F-40,000		FDRK 424 OB	64

1.1 \

Heavy Duty Differential Index

Axle Model	Type/Cap.	Notes	Fersa Bearing Kit	Pg.
Eaton				
RC406	R-40,000		FDRK 1 OB	54
RP406-P	R-40,000		FDRK 1 OB	54
RS406	R-40,000		FDRK 1A OB	54
RT406-P	R-40,000		FDRK 1 OB	54
DP440-P	F-44,000	22 Spline & Case # 103530	FDRK 209 OB	59
	F-44,000	36 Spline & Case # 110500	FDRK 210 OB	59
DS440-P	F-44,000	22 Spline & Case # 103530	FDRK 208A OB	59
	F-44,000	36 Spline & Case # 110500	FDRK 208 OB	59
DT440-P	F-44,000	22 Spline & Case # 103530	FDRK 209 OB	59
	F-44,000	36 Spline & Case # 110500	FDRK 210 OB	59
RP440	R-44,000		FDRK 72B OB	55
RS440	R-44,000		FDRK 18E OB	54
RT440	R-44,000		FDRK 72B OB	55
DP446-P	F-44,000		FDRK 426 OB	65
DS446-P	F-44,000	w/ Traction Control	FDRK 426 OB	65
	F-44,000	w/o Traction Control	FDRK 425 OB	65
DT446-P	F-44,000		FDRK 426 OB	65
RP446-P	R-44,000		FDRK 72B OB	55
RS446	R-44,000	w/ Traction Control	FDRK 72B OB	55
	R-44,000	w/o Traction Control	FDRK 18E OB	54
RT446-P	R-44,000		FDRK 72B OB	55
DC451-P	F-45,000		FDRK 207 OB	59
DP451-P	F-45,000		FDRK 207 OB	59
DS451-P	F-45,000	4-6-89 thru 12-31-94	FDRK 222F OB	61
	F-45,000	After 1-1-95	FDRK 196 OB	58
	F-45,000	Before 4-6-89	FDRK 196 OB	58
DT451-P	F-45,000		FDRK 207 OB	59
RC451	R-45,000		FDRK 1 OB	54
RP451-P	R-45,000		FDRK 1 OB	54
RS451	R-45,000	4-6-89 thru 12-31-94	FDRK 222R OB	61
	R-45,000	After 1-1-95	FDRK 412 OB	63
	R-45,000	Before 4-6-89	FDRK 1A OB	54
RT451-P	R-45,000		FDRK 1 OB	54
DA454(P)	F-45,000		FDRK 404F OB	61
DD454(P)	F-45,000		FDRK 405F OB	62
DS454(P)	F-45,000		FDRK 404F OB	61
RA454	R-45,000		FDRK 404R OB	62
RD454	R-45,000		FDRK 405R OB	62
RS454	R-45,000		FDRK 404R OB	62
DC460-P	F-46,000		FDRK 211F OB	60
DP460-P	F-46,000	22 Spline & Case # 103530	FDRK 209 OB	59
	F-46,000	36 Spline & Case # 110500	FDRK 210 OB	59
DS460-P	F-46,000	22 Spline & Case # 103530	FDRK 208A OB	59
	F-46,000	36 Spline & Case # 110500	FDRK 208 OB	59
DT460-P	F-46,000	22 Spline & Case # 103530	FDRK 209 OB	59
	F-46,000	36 Spline & Case # 110500	FDRK 210 OB	59
RC460	R-46,000		FDRK 219R OB	60
RP460	R-46,000		FDRK 72B OB	55
RS460	R-46,000		FDRK 18E OB	54
RT460	R-46,000		FDRK 72B OB	55
DC461-P	F-46,000	After 2/2000	FDRK 432 OB	66
	F-46,000	Prior 2/2000	FDRK 211F OB	60

Axle Model	Type/Cap.	Notes	Fersa Bearing Kit	Pg.
Eaton				
DD461-P	F-46,000	After 2/2000	FDRK 432 OB	66
	F-46,000	Prior 2/2000	FDRK 211F OB	60
DP461-P	F-46,000	After 2/2000	FDRK 432 OB	66
	F-46,000	Prior 2/2000	FDRK 211F OB	60
DS461-P	F-46,000	After 2/2000	FDRK 433 OB	66
	F-46,000	Prior 2/2000	FDRK 208 OB	59
DT461-P	F-46,000	After 2/2000	FDRK 432 OB	66
	F-46,000	Prior 2/2000	FDRK 211F OB	60
RC461	R-46,000		FDRK 219R OB	60
RD461	R-46,000		FDRK 219R OB	60
RP461	R-46,000		FDRK 219R OB	60
RS461	R-46,000		FDRK 449 OB	68
RT461	R-46,000		FDRK 219R OB	60
SP461	R-46,000		FDRK 220F OB	60
TP461	F-46,000		FDRK 220F OB	60
DC462-P	F-46,000	After 2/2000	FDRK 432 OB	66
	F-46,000	Prior 2/2000	FDRK 211F OB	60
DD462-P	F-46,000	After 2/2000	FDRK 432 OB	66
	F-46,000	Prior 2/2000	FDRK 211F OB	60
DP462-P	F-46,000	After 2/2000	FDRK 432 OB	66
	F-46,000	Prior 2/2000	FDRK 211F OB	60
DS462-P	F-46,000	After 2/2000	FDRK 433 OB	66
	F-46,000	Prior 2/2000	FDRK 208 OB	59
DT462-P	F-46,000	After 2/2000	FDRK 432 OB	66
	F-46,000	Prior 2/2000	FDRK 211F OB	60
RC462	R-46,000		FDRK 219R OB	60
RD462	R-46,000		FDRK 219R OB	60
RP462	R-46,000		FDRK 219R OB	60
RS462	R-46,000		FDRK 449 OB	68
RT462	R-46,000		FDRK 219R OB	60
SP462	R-46,000		FDRK 220F OB	60
TP462	F-46,000		FDRK 220F OB	60
DC463-P	F-46,000	After 2/2000	FDRK 432 OB	66
	F-46,000	Prior 2/2000	FDRK 211F OB	60
DD463-P	F-46,000	After 2/2000	FDRK 432 OB	66
	F-46,000	Prior 2/2000	FDRK 211F OB	60
DP463-P	F-46,000	After 2/2000	FDRK 432 OB	66
	F-46,000	Prior 2/2000	FDRK 211F OB	60
DS463-P	F-46,000	After 2/2000	FDRK 433 OB	66
	F-46,000	Prior 2/2000	FDRK 208 OB	59
DT463-P	F-46,000	After 2/2000	FDRK 432 OB	66
	F-46,000	Prior 2/2000	FDRK 211F OB	60
RC463	R-46,000		FDRK 219R OB	60
RD463	R-46,000		FDRK 219R OB	60
RP463	R-46,000		FDRK 219R OB	60
RS463	R-46,000		FDRK 449 OB	68
RT463	R-46,000		FDRK 219R OB	60
SP463	R-46,000		FDRK 220F OB	60
TP463	F-46,000		FDRK 220F OB	60
DP466-P	F-46,000		FDRK 426 OB	65
DS466-P	F-46,000	w/ Traction Control	FDRK 426 OB	65
	F-46,000	w/o Traction Control	FDRK 425 OB	65
DT466-P	F-46,000		FDRK 426 OB	65
RP466-P	R-46,000		FDRK 72B OB	55

1.1 \

Heavy Duty Differential Index

Axle Model	Type/Cap.	Notes	Fersa Bearing Kit	Pg.
Eaton				
RS466	R-46,000	w/ Traction Control	FDRK 72B OB	55
	R-46,000	w/o Traction Control	FDRK 18E OB	54
RT466-P	R-46,000		FDRK 72B OB	55
DC480-P	F-48,000		FDRK 211F OB	60
DP480-P	F-48,000	22 Spline & Case # 103530	FDRK 209 OB	59
	F-48,000	36 Spline & Case # 110500	FDRK 210 OB	59
DS480-P	F-48,000	22 Spline & Case # 103530	FDRK 208A OB	59
	F-48,000	36 Spline & Case # 110500	FDRK 208 OB	59
DT480-P	F-48,000	22 Spline & Case # 103530	FDRK 209 OB	59
	F-48,000	36 Spline & Case # 110500	FDRK 210 OB	59
RC480	R-48,000		FDRK 219R OB	60
RP480	R-48,000		FDRK 72B OB	55
RS480	R-48,000		FDRK 18E OB	54
RT480	R-48,000		FDRK 72B OB	55
DP485-P	F-48,000		FDRK 211F OB	60
DT485-P	F-48,000		FDRK 211F OB	60
RP485	R-48,000		FDRK 72B OB	55
RT485	R-48,000		FDRK 72B OB	55
DC521-P	F-52,000	After 2/2000	FDRK 432 OB	66
	F-52,000	Prior 2/2000	FDRK 211F OB	60
DD521-P	F-52,000	After 2/2000	FDRK 432 OB	66
	F-52,000	Prior 2/2000	FDRK 211F OB	60
DP521-P	F-52,000	After 2/2000	FDRK 432 OB	66
	F-52,000	Prior 2/2000	FDRK 211F OB	60
DS521-P	F-52,000	After 2/2000	FDRK 433 OB	66
	F-52,000	Prior 2/2000	FDRK 208 OB	59
DT521-P	F-52,000	After 2/2000	FDRK 432 OB	66
	F-52,000	Prior 2/2000	FDRK 211F OB	60
RC521	R-52,000		FDRK 219R OB	60
RD521	R-52,000		FDRK 219R OB	60
RP521	R-52,000		FDRK 219R OB	60
RS521	R-52,000		FDRK 449 OB	68
RT521	R-52,000		FDRK 219R OB	60
SP521	R-52,000		FDRK 220F OB	60
TP521	F-52,000		FDRK 220F OB	60
DP550	F-55,000	22 Spline & Case # 103530	FDRK 211FA OB	60
	F-55,000	36 Spline & Case # 110500	FDRK 211F OB	60
RP550	R-55,000		FDRK 72B OB	55
RT550	R-55,000		FDRK 72B OB	55
SP550	F-55,000		FDRK 220FA OB	61
TP550	F-55,000		FDRK 220FA OB	61
DP580-P	F-58,000	22 Spline & Case # 103530	FDRK 211FA OB	60
	F-58,000	36 Spline & Case # 110500	FDRK 211F OB	60
DT580-P	F-58,000	22 Spline & Case # 103530	FDRK 211FA OB	60
	F-58,000	36 Spline & Case # 110500	FDRK 211F OB	60
RP580	R-58,000		FDRK 219R OB	60
RS580	R-58,000	w/ Traction Control	FDRK 219R OB	60
RT580	R-58,000		FDRK 219R OB	60
SP580	F-58,000		FDRK 220FA OB	61
TP580	F-58,000		FDRK 220FA OB	61
DD581-P	F-58,000	After 2/2000	FDRK 432 OB	66
	F-58,000	Prior 2/2000	FDRK 211F OB	60
DS581-P	F-58,000	After 2/2000	FDRK 433 OB	66
	F-58,000	Prior 2/2000	FDRK 208 OB	59

Axle Model	Type/Cap.	Notes	Fersa Bearing Kit	Pg.
Eaton				
RD581	R-58,000		FDRK 219R OB	60
RS581	R-58,000		FDRK 449 OB	68
DD601(P)	F-60,000	After 2/2000	FDRK 432 OB	66
	F-60,000	Prior 2/2000	FDRK 211F OB	60
DP601-P	F-60,000	After 2/2000	FDRK 432 OB	66
	F-60,000	Prior 2/2000	FDRK 211F OB	60
DS601(P)	F-60,000	After 2/2000	FDRK 433 OB	66
	F-60,000	Prior 2/2000	FDRK 208 OB	59
DT601-P	F-60,000	After 2/2000	FDRK 432 OB	66
	F-60,000	Prior 2/2000	FDRK 211F OB	60
RC601	R-60,000		FDRK 219R OB	60
RP601	R-60,000		FDRK 219R OB	60
RS601	R-60,000		FDRK 449 OB	68
RT601	R-60,000		FDRK 219R OB	60
SP601	R-60,000		FDRK 220F OB	60
TP601	F-60,000		FDRK 220F OB	60
DP650-P	F-65,000	22 Spline & Case # 103530	FDRK 211FA OB	60
	F-65,000	36 Spline & Case # 110500	FDRK 211F OB	60
DT650-P	F-65,000	22 Spline & Case # 103530	FDRK 211FA OB	60
	F-65,000	36 Spline & Case # 110500	FDRK 211F OB	60
RP650	R-65,000		FDRK 219R OB	60
RS650	R-65,000	w/ Traction Control	FDRK 219R OB	60
RT650	R-65,000		FDRK 219R OB	60
SP650	F-65,000		FDRK 220FA OB	61
TP650	F-65,000		FDRK 220FA OB	61
DD651(P)	F-65,000	After 2/2000	FDRK 432 OB	66
	F-65,000	Prior 2/2000	FDRK 211F OB	60
DP651-P	F-65,000	After 2/2000	FDRK 432 OB	66
	F-65,000	Prior 2/2000	FDRK 211F OB	60
DS651-P	F-65,000	After 2/2000	FDRK 433 OB	66
	F-65,000	Prior 2/2000	FDRK 208 OB	59
DT651-P	F-65,000	After 2/2000	FDRK 432 OB	66
	F-65,000	Prior 2/2000	FDRK 211F OB	60
RC651	R-65,000		FDRK 219R OB	60
RP651	R-65,000		FDRK 219R OB	60
RS651	R-65,000		FDRK 449 OB	68
RT651	R-65,000		FDRK 219R OB	60
SP651	R-65,000		FDRK 220F OB	60
TP651	F-65,000		FDRK 220F OB	60
DP652-P	F-65,000	Prior 2/2000	FDRK 211F OB	60
	F-65,000	After 2/2000	FDRK 432 OB	66
RP652	R-65,000		FDRK 219R OB	60
DC3416-P	F-34,000		FDRK 424 OB	64
DP3416-P	F-34,000		FDRK 424 OB	64
DS3416-P	F-34,000		FDRK 422 OB	64
DT3416-P	F-34,000		FDRK 424 OB	64
RC3416	R-34,000		FDRK 1 OB	54
RP3416-P	R-34,000		FDRK 1 OB	54
RS3416	R-34,000		FDRK 1A OB	54
RT3416-P	R-34,000		FDRK 1 OB	54
DC4026-P	F-40,000		FDRK 424 OB	64
DP4026-P	F-40,000		FDRK 424 OB	64

1.1 \ Heavy Duty Differential Index

Axle Model	Type/Cap.	Notes	Fersa Bearing Kit	Pg.
Eaton				
DS4026-P	F-40,000		FDRK 422 OB	64
DT4026-P	F-40,000		FDRK 424 OB	64
RC4026	R-40,000		FDRK 1 OB	54
RP4026-P	R-40,000		FDRK 1 OB	54
RS4026	R-40,000		FDRK 1A OB	54
RT4026-P	R-40,000		FDRK 1 OB	54
DC4616-P	F-46,000		FDRK 426 OB	65
DP4616-P	F-46,000		FDRK 426 OB	65
DS4616-P	F-46,000		FDRK 423 OB	64
DT4616-P	F-46,000		FDRK 426 OB	65
RC4616	R-46,000		FDRK 72B OB	55
RP4616-P	R-46,000		FDRK 219R OB	60
RS4616	R-46,000		FDRK 449 OB	68
RT4616-P	R-46,000		FDRK 219R OB	60
DC5216-P	F-52,000		FDRK 426 OB	65
DP5216-P	F-52,000		FDRK 426 OB	65
DS5216-P	F-52,000		FDRK 423 OB	64
DT5216-P	F-52,000		FDRK 426 OB	65
RC5216	R-52,000		FDRK 72B OB	55
RP5216-P	R-52,000		FDRK 219R OB	60
RS5216	R-52,000		FDRK 449 OB	68
RT5216-P	R-52,000		FDRK 219R OB	60
DP6016-P	F-60,000		FDRK 426 OB	65
DT6016-P	F-60,000		FDRK 426 OB	65
RP6016-P	R-60,000		FDRK 219R OB	60
RT6016-P	R-60,000		FDRK 219R OB	60
DP6516-P	F-65,000		FDRK 426 OB	65
DT6516-P	F-65,000		FDRK 426 OB	65
RP6516-P	R-65,000		FDRK 219R OB	60
RT6516-P	R-65,000		FDRK 219R OB	60
350	R-		FDRK 24 OB	55
502	R-		FDRK 72 OB	55
503	R-		FDRK 72 OB	55
1350	R-10-15,000	Exc. Dodge 1957-1958	FDRK 24 OB	55
1618	R-16-17,000		FDRK 23 OB	54
1619	R-16-17,000		FDRK 23 OB	54
1880	R-19-22,000		FDRK 1 OB	54
1881	R-19-22,000		FDRK 1 OB	54
3800	R-15,000		FDRK 24 OB	55
3802	R-15,000		FDRK 24 OB	55
6802	R-16,000		FDRK 23 OB	54
6803	R-16,000		FDRK 23 OB	54
7500	F-		FDRK 202 OB	58
7800	R-18,000		FDRK 1 OB	54
7801	R-18,000		FDRK 1 OB	54
7810	R-18,000		FDRK 1 OB	54
8800	R-22,000		FDRK 1 OB	54
8802	R-22,000		FDRK 1 OB	54
8803	R-22,000		FDRK 1 OB	54
9000	F-		FDRK 202 OB	58
9502	R-23,000		FDRK 72 OB	55
9503	R-23,000		FDRK 72 OB	55
9512	R-23,000		FDRK 72 OB	55

Axle Model	Type/Cap.	Notes	Fersa Bearing Kit	Pg.
Eaton				
10000	F-		FDRK 202 OB	58
12000	F-		FDRK 202 OB	58
13600	R-13,000		FDRK 411 OB	63
13602	R-13,000		FDRK 411 OB	63
13800	R-13,000		FDRK 24 OB	55
13802	R-13,000		FDRK 24 OB	55
13803	R-13,000		FDRK 24 OB	55
15040-P	R-15,000		FDRK 24 OB	55
15040-S	R-15,000		FDRK 400 OB	61
15040-T	R-15,000		FDRK 24 OB	55
15101	R-15,000		FDRK 24 OB	55
15200	R-15,000		FDRK 24 OB	55
15201	R-15,000		FDRK 24 OB	55
15300	R-15,000		FDRK 24 OB	55
15301	R-15,000		FDRK 24 OB	55
16120	R-16,000		FDRK 23D OB	55
16123	R-16,000		FDRK 23D OB	55
16220	R-16,000	w/ 15" Ring Gear	FDRK 23 OB	54
	R-16,000	w/ 15-1/2" Ring Gear	FDRK 23D OB	55
16244	R-16,000		FDRK 23D OB	55
16247	R-17,500		FDRK 23D OB	55
16320	R-16,000		FDRK 23 OB	54
16321	R-16,000		FDRK 23 OB	54
16344	R-16,000		FDRK 23D OB	55
16500	R-16,000		FDRK 23 OB	54
16501	R-16,000		FDRK 23 OB	54
16800	R-16,000		FDRK 23 OB	54
16802	R-16,000		FDRK 23 OB	54
16803	R-16,000		FDRK 23 OB	54
17060-S	R-17,000		FDRK 404R OB	62
17100	R-17,000		FDRK 1A OB	54
17101	R-17,000		FDRK 1A OB	54
17120	R-17,000		FDRK 1A OB	54
17121	R-17,000		FDRK 1A OB	54
17123	R-17,000		FDRK 1A OB	54
17200	R-17,000		FDRK 1 OB	54
17201	R-17,000		FDRK 1 OB	54
17202	R-17,000		FDRK 1 OB	54
17220	R-17,000		FDRK 1 OB	54
17221	R-17,000		FDRK 1 OB	54
17300	R-17,000		FDRK 1 OB	54
17301	R-17,000		FDRK 1 OB	54
17302	R-17,000		FDRK 1 OB	54
17320	R-17,000		FDRK 1 OB	54
17321	R-17,000		FDRK 1 OB	54
17322	R-17,000		FDRK 1 OB	54
17401	R-17,000		FDRK 1 OB	54
17421	R-17,000		FDRK 1 OB	54
17500	R-17,000		FDRK 1 OB	54
17501	R-17,000		FDRK 1 OB	54
17800	R-17,000		FDRK 1 OB	54
17810	R-17,000		FDRK 1 OB	54
18100	R-18,000		FDRK 1A OB	54

1.1 \ Heavy Duty Differential Index

Axle Model	Type/Cap.	Notes	Fersa Bearing Kit	Pg.
Eaton				
18101	R-18,000		FDRK 1A OB	54
18103	R-18,000		FDRK 1A OB	54
18120	R-18,000		FDRK 1A OB	54
18121	R-18,000		FDRK 1A OB	54
18123	R-18,000		FDRK 1A OB	54
18200	R-18,000		FDRK 1 OB	54
18201	R-18,000		FDRK 1 OB	54
18202	R-18,000		FDRK 1 OB	54
18207	R-18,000		FDRK 1 OB	54
18220	R-18,000		FDRK 1 OB	54
18221	R-18,000		FDRK 1 OB	54
18227	R-18,000		FDRK 1 OB	54
18300	R-18,000		FDRK 1 OB	54
18301	R-18,000		FDRK 1 OB	54
18302	R-18,000		FDRK 1 OB	54
18320	R-18,000		FDRK 1 OB	54
18321	R-18,000		FDRK 1 OB	54
18322	R-18,000		FDRK 1 OB	54
18500	R-18,000		FDRK 1 OB	54
18501	R-18,000		FDRK 1 OB	54
18502	R-18,000		FDRK 1 OB	54
18503	R-18,000		FDRK 1 OB	54
18800	R-18,000		FDRK 1 OB	54
18802	R-18,000		FDRK 1 OB	54
18803	R-18,000		FDRK 1 OB	54
18812	R-18,000		FDRK 1 OB	54
18813	R-18,000		FDRK 1 OB	54
19050-D	R-19,000		FDRK 221 OB	61
19050-P	R-19,000		FDRK 23D OB	55
19050-S	R-19,000		FDRK 221 OB	61
19050-T	R-19,000		FDRK 23D OB	55
19055-D	R-19,000		FDRK 406 OB	62
19055-P	R-19,000		FDRK 403 OB	61
19055-S	R-19,000		FDRK 406 OB	62
19055-T	R-19,000		FDRK 403 OB	61
19060-D	R-19,000		FDRK 405R OB	62
19060-S	R-19,000		FDRK 404R OB	62
19060-T	R-19,000		FDRK 1 OB	54
19100	R-19,000		FDRK 415 OB	63
19120	R-19,000		FDRK 18D OB	54
19121	R-19,000	Exc. Dodge	FDRK 18D OB	54
19123	R-19,000		FDRK 18D OB	54
19200	R-19,000		FDRK 72 OB	55
19201	R-19,000		FDRK 72 OB	55
19202	R-19,000		FDRK 72 OB	55
19220	R-19,000	w/ 103537 Case	FDRK 72B OB	55
	R-19,000	w/o 103537 Case	FDRK 72A OB	55
19221	R-19,000	w/ 103537 Case	FDRK 72B OB	55
	R-19,000	w/o 103537 Case	FDRK 72A OB	55
19223	R-19,000		FDRK 72A OB	55
19227	R-19,000	After 2-1-79	FDRK 219R OB	60
	R-19,000	Before 2-1-79	FDRK 413 OB	63
19237	R-19,000	After 2-1-79	FDRK 219R OB	60

Axle Model	Type/Cap.	Notes	Fersa Bearing Kit	Pg.
Eaton				
19300	R-19,000		FDRK 72 OB	55
19301	R-19,000		FDRK 72 OB	55
19320	R-19,000		FDRK 72A OB	55
19321	R-19,000	w/ 103537 Case	FDRK 72B OB	55
	R-19,000	w/o 103537 Case	FDRK 72A OB	55
19323	R-19,000		FDRK 72A OB	55
19327	R-19,000		FDRK 413 OB	63
19420	R-19,000		FDRK 413 OB	63
19426	R-19,000		FDRK 413 OB	63
19500	R-19,000		FDRK 72 OB	55
19501	R-19,000		FDRK 72 OB	55
19502	R-19,000		FDRK 72 OB	55
19503	R-19,000		FDRK 72 OB	55
19512	R-19,000		FDRK 72 OB	55
19513	R-19,000		FDRK 72 OB	55
19515	R-19,000		FDRK 72 OB	55
20000	R-20,000		FDRK 72 OB	55
P20060-D	R-20,000		FDRK 430 OB	65
P20060-S	R-20,000		FDRK 429 OB	65
20100	R-20,000		FDRK 415 OB	63
20120	R-20,000		FDRK 18D OB	54
20121	R-20,000		FDRK 18D OB	54
20123	R-20,000		FDRK 18D OB	54
20200	R-20,000		FDRK 72 OB	55
20201	R-20,000		FDRK 72 OB	55
20220	R-20,000	w/ 103537 Case	FDRK 72B OB	55
	R-20,000	w/o 103537 Case	FDRK 72A OB	55
20221	R-20,000	w/ 103537 Case	FDRK 72B OB	55
	R-20,000	w/o 103537 Case	FDRK 72A OB	55
20223	R-20,000		FDRK 72A OB	55
20300	R-20,000		FDRK 72 OB	55
20301	R-20,000		FDRK 72 OB	55
20320	R-20,000	w/ 103537 Case	FDRK 72B OB	55
	R-20,000	w/o 103537 Case	FDRK 72A OB	55
20321	R-20,000	w/ 103537 Case	FDRK 72B OB	55
	R-20,000	w/o 103537 Case	FDRK 72A OB	55
20323	R-20,000		FDRK 72A OB	55
20500	R-20,000		FDRK 72 OB	55
20501	R-20,000		FDRK 72 OB	55
20502	R-20,000		FDRK 72 OB	55
20503	R-20,000		FDRK 72 OB	55
21060-D	R-21,000		FDRK 405R OB	62
21060-S	R-21,000		FDRK 404R OB	62
21060-T	R-21,000		FDRK 1 OB	54
21065-D	R-21,000		FDRK 406 OB	62
21065-P	R-21,000		FDRK 403 OB	61
21065-S	R-21,000		FDRK 406 OB	62
21065-T	R-21,000		FDRK 403 OB	61
21065-Y	R-21,000		FDRK 403 OB	61
21080-D	R-21,000	Before 12-99	FDRK 410 OB	63
	R-21,000	After 12-99	FDRK 451 OB	68
21080-S	R-21,000	Before 12-99	FDRK 410 OB	63
	R-21,000	After 12-99	FDRK 451 OB	68

1.1 \

Heavy Duty Differential Index

Axle Model	Type/Cap.	Notes	Fersa Bearing Kit	Pg.
Eaton				
21090-D	R-21,000	Before 12-99	FDRK 410 OB	63
	R-21,000	After 12-99	FDRK 451 OB	68
21121	R-21,000		FDRK 1A OB	54
	R-21,000		FDRK 1 OB	54
21321	R-21,000		FDRK 1 OB	54
21421	R-21,000		FDRK 1 OB	54
22060-D	R-22,000		FDRK 405R OB	62
P22060-D	R-22,000		FDRK 430 OB	65
22060-S	R-22,000		FDRK 404R OB	62
P22060-S	R-22,000		FDRK 429 OB	65
22060-SH	R-22,000		FDRK 429 OB	65
22065-D	R-22,000		FDRK 406 OB	62
22065-P	R-22,000		FDRK 403 OB	61
22065-S	R-22,000		FDRK 406 OB	62
22065-T	R-22,000		FDRK 403 OB	61
22120	R-22,000		FDRK 412 OB	63
22121	R-22,000		FDRK 412 OB	63
22220	R-22,000		FDRK 403 OB	61
22221	R-22,000		FDRK 403 OB	61
22320	R-22,000		FDRK 403 OB	61
22321	R-22,000		FDRK 403 OB	61
22420	R-22,000		FDRK 403 OB	61
22421	R-22,000		FDRK 403 OB	61
22427	R-22,000		FDRK 403 OB	61
23060-SH	R-23,000		FDRK 429 OB	65
23070-D	R-23,000		FDRK 407 OB	63
23070-P	R-23,000		FDRK 408 OB	63
23070-S	R-23,000		FDRK 407 OB	63
23070-T	R-23,000		FDRK 408 OB	63
23080-D	R-23,000	Before 12-99	FDRK 410 OB	63
	R-23,000	After 12-99	FDRK 451 OB	68
23080-P	R-23,000	After 4-6-88	FDRK 219R OB	60
	R-23,000	Before 4-6-88	FDRK 72B OB	55
23080-S	R-23,000	Before 12-99	FDRK 410 OB	63
	R-23,000	After 12-99	FDRK 451 OB	68
23080-T	R-23,000	After 4-6-88	FDRK 219R OB	60
	R-23,000	Before 4-6-88	FDRK 72B OB	55
23082-P	R-23,000		FDRK 219R OB	60
23082-T	R-23,000		FDRK 219R OB	60
23085-C	R-23,000		FDRK 219R OB	60
23085-D	R-23,000		FDRK 410 OB	63
23085-S	R-23,000		FDRK 410 OB	63
23085-T	R-23,000	After 4-6-88	FDRK 219R OB	60
23090-D	R-23,000	After 12-99	FDRK 451 OB	68
23090-S	R-23,000	After 12-99	FDRK 451 OB	68
23105-C	R-23,000		FDRK 401 OB	61
23105-D	R-23,000		FDRK 409 OB	63
23105-S	R-23,000		FDRK 402 OB	61
23120	R-23,000	Large Spherical Differential	FDRK 18E OB	54
23121	R-23,000	GMC Trucks	FDRK 415 OB	63
	R-23,000	Non-GMC Trucks	FDRK 18E OB	54
23202	R-23,000		FDRK 72 OB	55
23220	R-23,000	w/ 27950 Case	FDRK 72A OB	55
	R-23,000	w/103537 Case	FDRK 72B OB	55

Axle Model	Type/Cap.	Notes	Fersa Bearing Kit	Pg.
Eaton				
23221	R-23,000	w/ 27950 Case	FDRK 72A OB	55
	R-23,000	w/103537 Case	FDRK 72B OB	55
23227	R-23,000	After 2-1-79	FDRK 219R OB	60
	R-23,000	Before 2-1-79	FDRK 413 OB	63
23302	R-23,000		FDRK 72 OB	55
23320	R-23,000	w/ 27950 Case	FDRK 72A OB	55
	R-23,000	w/103537 Case	FDRK 72B OB	55
23321	R-23,000	w/ 27950 Case	FDRK 72A OB	55
	R-23,000	w/103537 Case	FDRK 72B OB	55
23327	R-23,000	After 2-1-79	FDRK 219R OB	60
	R-23,000	Before 2-1-79	FDRK 413 OB	63
23420	R-23,000	After 2-1-79	FDRK 219R OB	60
	R-23,000	Before 2-1-79	FDRK 413 OB	63
23421	R-23,000		FDRK 219R OB	60
23427	R-23,000		FDRK 219R OB	60
23430	R-23,000	w/ CTD	FDRK 219R OB	60
23433	R-23,000		FDRK 219R OB	60
23437	R-23,000		FDRK 219R OB	60
26080-D	R-26,000	Before 12-99	FDRK 410 OB	63
	R-26,000	After 12-99	FDRK 451 OB	68
26080-P	R-26,000		FDRK 219R OB	60
26080-T	R-26,000		FDRK 219R OB	60
26085-D	R-26,000	Before 12-99	FDRK 410 OB	63
26085-S	R-26,000	Before 12-99	FDRK 410 OB	63
26085-P	R-26,000	After 4-6-88	FDRK 219R OB	60
	R-26,000	Before 4-6-88	FDRK 72B OB	55
26085-T	R-26,000	After 4-6-88	FDRK 219R OB	60
	R-26,000	Before 4-6-88	FDRK 72B OB	55
26090-D	R-26,000	After 12-99	FDRK 451 OB	68
26090-S	R-26,000	Before 12-99	FDRK 451 OB	68
26105-C	R-26,000		FDRK 401 OB	61
26105-S	R-26,000		FDRK 402 OB	61
26120	R-26,000	Large Spherical Differential	FDRK 18E OB	54
	R-26,000	Small Spherical Differential	FDRK 18D OB	54
26121	R-26,000	Large Spherical Differential	FDRK 18E OB	54
	R-26,000	Small Spherical Differential	FDRK 18D OB	54
26123	R-26,000	Large Spherical	FDRK 18E OB	54
	R-26,000	Small Spherical Differential	FDRK 18D OB	54
26220	R-26,000	w/ 27950 Case	FDRK 72A OB	55
	R-26,000	w/103537 Case	FDRK 72B OB	55
26221	R-26,000	w/ 27950 Case	FDRK 72A OB	55
	R-26,000	w/103537 Case	FDRK 72B OB	55
26223	R-26,000	w/ 27950 Case	FDRK 72A OB	55
	R-26,000	w/103537 Case	FDRK 72B OB	55
26320	R-26,000	w/ 27950 Case	FDRK 72A OB	55
	R-26,000	w/103537 Case	FDRK 72B OB	55
26321	R-26,000	w/ 27950 Case	FDRK 72A OB	55
	R-26,000	w/103537 Case	FDRK 72B OB	55
26323	R-26,000	w/ 27950 Case	FDRK 72A OB	55
	R-26,000	w/103537 Case	FDRK 72B OB	55
26420	R-26,000		FDRK 413 OB	63
26421	R-26,000		FDRK 219R OB	60

1.1 \

Heavy Duty Differential Index

Axle Model	Type/Cap.	Notes	Fersa Bearing Kit	Pg.
Eaton				
26426	R-26,000		FDRK 413 OB	63
30055-P	R-30,000		FDRK 219R OB	60
30105-C	R-30,000		FDRK 401 OB	61
30105-S	R-30,000		FDRK 402 OB	61
33321	R-33,000	w/ 27950 Case	FDRK 72A OB	55
	R-33,000	w/103537 Case	FDRK 72B OB	55
35055-P	R-35,000		FDRK 219R OB	60
35227	R-35,000	w/ 27950 Case	FDRK 413 OB	63
	R-35,000	w/103537 Case	FDRK 219R OB	60
	R-35,000	w/ 27950 Case	FDRK 413 OB	63
	R-35,000	w/103537 Case	FDRK 219R OB	60
GMC				
H052	R-5,200	1968-On	FDRK 700 OB	69
H072	R-7,200	1968-On	FDRK 700 OB	69
H110	R-11,000	Before 1983	FDRK 701 OB	69
H130	R-13,000	Late Models	FDRK 701 OB	69
H150	R-15,000	Before 1982	FDRK 702 OB	70
T150	R-15,000	1996-1983	FDRK 170 OB	56
H170	R-17,000	Before 1979	FDRK 702 OB	70
T170	R-17,000	1966-On	FDRK 170 OB	56
International Harvester/ Navistar				
RA15	R-6,000		FDRK 195 OB	58
RA25	R-13,500		FDRK 202 OB	58
RA29	R-15,500		FDRK 191R OB	56
RA30	R-15,000		FDRK 202 OB	58
RA35	R-16,000		FDRK 191R OB	56
RA39	R-16,000		FDRK 191R OB	56
RA42	R-	w/ Involute Splines	FDRK 192RB OB	57
	R-	w/o Involute Splines and Below Serial # 5141	FDRK 192RA OB	57
	R-	w/o Involute Splines and Serial # 5141 & Above	FDRK 192R OB	57
RA43	R-18,500	w/ Involute Splines	FDRK 192RB OB	57
	R-18,500	w/o Involute Splines and Below Serial # 5141	FDRK 192RA OB	57
	R-18,500	w/o Involute Splines and Serial # 5141 & Above	FDRK 192R OB	57
RA44	R-18,500	w/ Involute Splines	FDRK 192RB OB	57
	R-18,500	w/o Involute Splines and Below Serial # 5141	FDRK 192RA OB	57
	R-18,500	w/o Involute Splines and Serial # 5141 & Above	FDRK 192R OB	57
RA47	R-18,500	w/ Involute Splines	FDRK 192RB OB	57
	R-18,500	w/o Involute Splines and Below Serial # 5141	FDRK 192RA OB	57
	R-18,500	w/o Involute Splines and Serial # 5141 & Above	FDRK 192R OB	57
RA48	R-18,500	w/ Involute Splines	FDRK 192RB OB	57
	R-18,500	w/o Involute Splines and Below Serial # 5141	FDRK 192RA OB	57
	R-18,500	w/o Involute Splines and Serial # 5141 & Above	FDRK 192R OB	57
RA57	R-23,000	# G261412 & Up	FDRK 198 OB	58
	R-23,000	w/Involute Splines	FDRK 201R OB	58
RA341	RF-30,000		FDRK 191F OB	56
	RR-30,000		FDRK 191R OB	56
RA351	RF-34,000	Below Diff Ser . #21453	FDRK 192FC OB	57
	RF-34,000	Diff Ser . #21453 & Higher w/Tapered Drive Bearings	FDRK 192FB OB	57
	RR-34,000	Below Serial # 18798	FDRK 192RA OB	57
	RR-34,000	Involute Splines	FDRK 192RB OB	57
	RR-34,000	Serial # 18798 & Above	FDRK 192R OB	57

Axle Model	Type/Cap.	Notes	Fersa Bearing Kit	Pg.
International Harvester/ Navistar				
RA355	RF-38,000	Below Diff Ser . #21453	FDRK 192FC OB	57
	RF-38,000	Diff Ser . #21453 & Higher w/Tapered Drive Bearings	FDRK 192FB OB	57
	RR-38,000	Below Diff Ser. # 18798	FDRK 192RA OB	57
	RR-38,000	Diff Ser. # 19798 & Up	FDRK 192R OB	57
	RR-38,000	Involute Splines	FDRK 192RB OB	57
RA386	RF-	Below Diff Ser . #21453	FDRK 192FC OB	57
	RF-	Diff Ser . #21453 & Higher w/Tapered Drive Bearings	FDRK 192FB OB	57
	RR-	Below Diff Ser. # 18798	FDRK 192RA OB	57
	RR-	Diff Ser. # 18798 & Up	FDRK 192R OB	57
	RR-	w/Involute Splines	FDRK 192RB OB	57
RA387	RF-	Below Diff Ser . #21453	FDRK 192FC OB	57
	RF-	Diff Ser . #21453 & Higher w/Tapered Drive Bearings	FDRK 192FB OB	57
	RR-	Below Diff Ser. # 18798	FDRK 192RA OB	57
	RR-	Diff Ser. # 18798 & Up	FDRK 192R OB	57
	RR-	w/Involute Splines	FDRK 192RB OB	57
RA429	RF-		FDRK 198 OB	58
	RR-	w/Involute Splines	FDRK 201R OB	58
RA472	RF-	Involute Splines	FDRK 200F OB	58
	RF-	Involute Splines (Late Design)	FDRK 200FA OB	58
	RR-	Involute Splines	FDRK 192RB OB	57
RA474	RF-46,000	Involute Splines	FDRK 201F OB	58
	RF-46,000	Involute Splines (Late Design)	FDRK 201FA OB	58
	RR-46,000	Involute Splines	FDRK 201R OB	58

Mack

RAD23	R-		FDRK 117 OB	56
SW29	RF-& RR-		FDRK 205 OB	59
SW30	RF-& RR-		FDRK 205 OB	59
SW31	RF-& RR-		FDRK 205 OB	59
CRDP32			FDRK 504 OB	69
SWD32	RF-& RR-		FDRK 206 OB	59
CRD33			FDRK 505 OB	69
AWDR48	RF-& RR-		FDRK 117 OB	56
SWS59	RF-		FDRK 212F OB	60
	RR-		FDRK 212R OB	60
SWW59	RF-		FDRK 212F OB	60
	RR-		FDRK 212R OB	60
SS65	RF-		FDRK 212F OB	60
	RR-		FDRK 212R OB	60
SW65	RF-		FDRK 212F OB	60
	RR-		FDRK 212R OB	60
SWD69	RF-		FDRK 212F OB	60
	RR-		FDRK 212R OB	60
SWW69	RF-		FDRK 212F OB	60
	RR-		FDRK 212R OB	60
SWW69W	RF-		FDRK 212F OB	60
	RR-		FDRK 212R OB	60
CRD78	R-22,000		FDRK 117 OB	56
SW80	RF-		FDRK 212F OB	60
	RR-		FDRK 212R OB	60
CRDLP92		w/11KH5312, 5313	FDRK 206 OB	59
		w/11KH5313	FDRK 206 OB	59
		w/11KH5316, 5317, 5318, 5319	FDRK 206 OB	59
SWS92	RF-		FDRK 212F OB	60
	RR-		FDRK 212R OB	60

1.1 \ Heavy Duty Differential Index

Axle Model	Type/Cap.	Notes	Fersa Bearing Kit	Pg.
Mack				
CRD93		Non-Current w/11KH5326, 5327, 5330	FDRK 502 OB FDRK 205 OB	68 59
CRD93A			FDRK 503 OB	68
CRDLP93			FDRK 205 OB	59
SWS93	RF- RR-		FDRK 212F OB FDRK 212R OB	60 60
CRD94			FDRK 117 OB	56
CRDP95			FDRK 212F OB	60
SWWP95	RF- RR-		FDRK 212F OB FDRK 212R OB	60 60
CRD96			FDRK 212R OB	60
CRDPC112		w/11KH5333, 5334, 5336	FDRK 206 OB	59
CRD113		Non-Current w/11KH5341, 5342	FDRK 502 OB FDRK 205 OB	68 59
CRD116	R-22,000 R-22,000	Non-Current w/11KHA4165, 4165A	FDRK 117A OB FDRK 117 OB	56 56
CRD117		Non-Current w/11KHA4159API-AP14 w/11KHA45159CP12	FDRK 117A OB FDRK 117 OB FDRK 117 OB	56 56 56
CRD118			FDRK 506 OB	69
C150	F-		FDRK 507 OB	69
CRD150	F-		FDRK 507 OB	69
CRDPC150	F-		FDRK 507 OB	69
C151	R-		FDRK 508 OB	69
CRD151	R-		FDRK 508 OB	69
CRDP200			FDRK 500 OB	68
CRD201			FDRK 501 OB	68
CRD202			FDRK 500 OB	68
CRD203			FDRK 501 OB	68
RAD303	R-		FDRK 117 OB	56
RAD305	R-		FDRK 117 OB	56
RAD500	R-		FDRK 117 OB	56
RAS500	R-		FDRK 117 OB	56
RAD501	R-		FDRK 117 OB	56
RAD507	R-22,000		FDRK 117 OB	56
RAD508	R-22,000		FDRK 117 OB	56
RAD509	R-22,000		FDRK 117 OB	56
RAD512	R-22,000		FDRK 117 OB	56
RAD529	R-23,000		FDRK 117 OB	56
RAD529CW	R-		FDRK 117 OB	56
RADL529	R-23,000		FDRK 117 OB	56
RAD530	R-23,000		FDRK 117 OB	56
RAD530C	R-		FDRK 117 OB	56
SWS592	RF- RR-		FDRK 212F OB FDRK 212R OB	60 60
SWW592	RF- RR-		FDRK 212F OB FDRK 212R OB	60 60
RAD606	R-27,000		FDRK 117 OB	56
RAD606C	R-		FDRK 117 OB	56
SWD691	RF- RR-		FDRK 212F OB FDRK 212R OB	60 60
RAD705	R-41,000		FDRK 117 OB	56

Axle Model	Type/Cap.	Notes	Fersa Bearing Kit	Pg.
Mack				
CRD781	R-22,000		FDRK 117 OB	56
SWP801	RF-		FDRK 212F OB	60
	RR-		FDRK 212R OB	60
RADF1000	R-		FDRK 117 OB	56
	R-		FDRK 117 OB	56
RADP1001	R-		FDRK 117 OB	56
CRD1161	R-22,000	Non-Current	FDRK 117A OB	56
	R-22,000	w/11KHA4159,4159A,4 166,4166A	FDRK 117 OB	56
CRD1171	R-22,000	Non-Current	FDRK 117A OB	56
	R-22,000	w/11KHA4159C, 4167B	FDRK 117 OB	56
	R-22,000	w/11KHA4167, 4167A	FDRK 117 OB	56
CRDPC1501	F-		FDRK 507 OB	69
CRD1511	R-		FDRK 508 OB	69
RAD5291	R-23,000		FDRK 117 OB	56
RADL5291	R-23,000		FDRK 117 OB	56



A series of horizontal dotted lines for handwritten notes or comments.

1.1 \ Heavy Duty Differential Index

Axle Model	Sub Model	Type/Cap.	Carrier	Notes	Fersa Bearing Kit	Pg.
------------	-----------	-----------	---------	-------	-------------------	-----

Meritor

14X Series Single Axles						
MS-17-14X		R-17,000	All	Hypoid w/o Diff Lock	FDRK 4843 OB	75
		R-17,000		Hypoid w/ Diff Lock	FDRK 4844 OB	75
MS-19-14X		R-17,000	All	Hypoid w/o Diff Lock	FDRK 4843 OB	75
		R-17,000		Hypoid w/ Diff Lock	FDRK 4844 OB	75
MS-21-14X		R-17,000	All	Hypoid w/o Diff Lock	FDRK 4843 OB	75
		R-17,000		Hypoid w/ Diff Lock	FDRK 4844 OB	75

14X Series Tandem Axles						
MD-34-14X	MD-17-14X	RF-17,000	All	Amboid Hypoid w/o Diff Lock Hypoid w/ Diff Lock	FDRK 4841 OB	75
	MR-17-14X	RR-17,000	All		FDRK 4842 OB	75
	MR-17-14X	RR-17,000			FDRK 4843 OB	75
	MR-17-14X	RR-17,000			FDRK 4844 OB	75
MD-40-14X	MD-20-14X	RF-20,000	All	Amboid Hypoid w/o Diff Lock Hypoid w/ Diff Lock	FDRK 4841 OB	75
	MR-20-14X	RR-20,000	All		FDRK 4842 OB	75
	MR-20-14X	RR-20,000			FDRK 4843 OB	75
	MR-20-14X	RR-20,000			FDRK 4844 OB	75
MT-44-14X	MD-22-14X	RF-22,000	All	Hypoid w/o Diff Lock Hypoid w/ Diff Lock	FDRK 4841 OB	75
	MR-22-14X	RR-22,000	All		FDRK 4843 OB	75
	MR-22-14X	RR-22,000			FDRK 4844 OB	75

113 Series Single Axle						
MS-10-113		R-10,000	All		FDRK 4753 OB	75
MS-11-113		R-11,000	All		FDRK 4753 OB	75
MS-12-113		R-12,000	All		FDRK 4753 OB	75

120, 125 Series Single Axle						
RS-13-120		R-13,000	All		FDRK 218 OB	60
RS-15-120		R-15,000	All		FDRK 218 OB	60
RS-15-125		R-15,000	All		FDRK 218 OB	60

140,141,143,144 & 145 Series Single Axle						
RS-16-140		R-16,000	L1676		FDRK 4350 OB	73
		R-16,000	M1547		FDRK 4345 OB	73
RS-16-141		R-16,000	All		FDRK 217R OB	60
RS-17-140		R-17,000	L1676		FDRK 4350 OB	73
		R-17,000	M1547		FDRK 4345 OB	73
RS-17-141		R-17,000	All		FDRK 217R OB	60
RS-17-144		R-17,000	D1850		FDRK 217R OB	60
		R-17,000	E1851		FDRK 217R OB	60
		R-17,000	G1879		FDRK 4390 OB	73
		R-17,000	L1676		FDRK 217R OB	60
		R-17,000	M1885		FDRK 217R OB	60
		R-17,000	Q1785		FDRK 217R OB	60
		R-17,000	R1500		FDRK 224 OB	61
		R-17,000	S1895		FDRK 217R OB	60
		R-17,000	X1558		FDRK 4390 OB	73
		RS-17-145		R-17,000	All	
RS-19-144		R-19,000	D1850		FDRK 217R OB	60
		R-19,000	E1851		FDRK 217R OB	60
		R-19,000	G1879		FDRK 4390 OB	73
		R-19,000	L1676		FDRK 217R OB	60
		R-19,000	M1885		FDRK 217R OB	60
		R-19,000	Q1785		FDRK 217R OB	60
		R-19,000	R1500		FDRK 224 OB	61
		R-19,000	S1895		FDRK 217R OB	60
		R-19,000	X1558		FDRK 4390 OB	73

Axle Model	Sub Model	Type/Cap.	Carrier	Notes	Fersa Bearing Kit	Pg.
------------	-----------	-----------	---------	-------	-------------------	-----

Meritor

140,141,143,144 & 145 Series Single Axle

RS-19-145		R-19,000	All		FDRK 217R OB	60
RS-21-145		R-21,000	D1850		FDRK 217R OB	60
		R-21,000	E1851		FDRK 217R OB	60
		R-21,000	G1879		FDRK 4390 OB	73
		R-21,000	L1676		FDRK 217R OB	60
		R-21,000	M1885		FDRK 217R OB	60
		R-21,000	Q1785		FDRK 217R OB	60
		R-21,000	R1500		FDRK 224 OB	61
		R-21,000	S1895		FDRK 217R OB	60
		R-21,000	X1558		FDRK 4390 OB	73

140,141,143,144 & 145 Series Tandem Axle

RT-34-144	RD-17-144	RF-17,000	B1978	Prior to 11/93 w/ Original 39 Spline Input	FDRK 217F OB	60
	RD-17-144	RF-17,000	B1978	Prior to 11/93 w/ New 46 Spline Input	FDRK 4395 OB	73
	RD-17-144	RF-17,000	B1978	After 11/93	FDRK 4396 OB	74
	RD-17-144	RF-17,000	C1979	Prior to 11/93 w/ Original 39 Spline Input	FDRK 217F OB	60
	RD-17-144	RF-17,000	C1979	Prior to 11/93 w/ New 46 Spline Input	FDRK 4395 OB	73
	RD-17-144	RF-17,000	C1979	After 11/93	FDRK 4396 OB	74
	RD-17-144	RF-17,000	E1903	Prior to 11/93	FDRK 4405 OB	74
	RD-17-144	RF-17,000	E1903	After 11/93	FDRK 4406 OB	74
	RD-17-144	RF-17,000	E1981	Prior to 11/93	FDRK 4405 OB	74
	RD-17-144	RF-17,000	E1981	After 11/93	FDRK 4406 OB	74
	RD-17-144	RF-17,000	F1852	Prior to 11/93 w/ Original 39 Spline Input	FDRK 217F OB	60
	RD-17-144	RF-17,000	F1852	Prior to 11/93 w/ New 46 Spline Input	FDRK 4395 OB	73
	RD-17-144	RF-17,000	F1852	After 11/93	FDRK 4396 OB	74
	RD-17-144	RF-17,000	G1645	Prior to 11/93 w/ Original 39 Spline Input	FDRK 217F OB	60
	RD-17-144	RF-17,000	G1645	Prior to 11/93 w/ New 46 Spline Input	FDRK 4395 OB	73
	RD-17-144	RF-17,000	G1645	After 11/93	FDRK 4396 OB	74
	RD-17-144	RF-17,000	M1677	Prior to 11/93	FDRK 4405 OB	74
	RD-17-144	RF-17,000	M1677	After 11/93	FDRK 4406 OB	74
	RD-17-144	RF-17,000	N1860	Prior to 11/93 w/ Original 39 Spline Input	FDRK 217F OB	60
	RD-17-144	RF-17,000	N1860	Prior to 11/93 w/ New 46 Spline Input	FDRK 4395 OB	73
	RD-17-144	RF-17,000	N1860	After 11/93	FDRK 4396 OB	74
	RD-17-144	RF-17,000	R1890	Prior to 11/93	FDRK 4405 OB	74
	RD-17-144	RF-17,000	R1890	After 11/93	FDRK 4406 OB	74
	RD-17-144	RF-17,000	S1917	Prior to 11/93 w/ Original 39 Spline Input	FDRK 217F OB	60
	RD-17-144	RF-17,000	S1917	Prior to 11/93 w/ New 46 Spline Input	FDRK 4395 OB	73
	RD-17-144	RF-17,000	S1917	After 11/93	FDRK 4396 OB	74
	RD-17-144	RF-17,000	T1814	Prior to 11/93 w/ Original 39 Spline Input	FDRK 217F OB	60
	RD-17-144	RF-17,000	T1814	Prior to 11/93 w/ New 46 Spline Input	FDRK 4395 OB	73
	RD-17-144	RF-17,000	T1814	After 11/93	FDRK 4396 OB	74
	RD-17-144	RF-17,000	U1815	Prior to 11/93	FDRK 4405 OB	74
	RD-17-144	RF-17,000	U1815	After 11/93	FDRK 4406 OB	74
	RP-17-144	RF-17,000	D1902	Prior to 11/93	FDRK 4405 OB	74
	RP-17-144	RF-17,000	D1902	After 11/93	FDRK 4406 OB	74
	RP-17-144	RF-17,000	G1853	Prior to 11/93 w/ Original 39 Spline Input	FDRK 217F OB	60
	RP-17-144	RF-17,000	G1853	Prior to 11/93 w/ New 46 Spline Input	FDRK 4395 OB	73

1.1 \ Heavy Duty Differential Index

Axle Model	Sub Model	Type/Cap.	Carrier	Notes	Fersa Bearing Kit	Pg.	
Meritor							
140,141,143,144 & 145 Series Tandem Axle							
RT-34-144	RP-17-144	RF-17,000	G1853	After 11/93	FDRK 4396 OB	74	
	RP-17-144	RF-17,000	H1984	Prior to 11/93 w/Original 39 Spline Input	FDRK 217F OB	60	
	RP-17-144	RF-17,000	H1984	Prior to 11/93 w/ New 46 Spline Input	FDRK 4395 OB	73	
	RP-17-144	RF-17,000	H1984	After 11/93	FDRK 4396 OB	74	
	RP-17-144	RF-17,000	K1987	Prior to 11/93	FDRK 4405 OB	60	
	RP-17-144	RF-17,000	K1987	After 11/93	FDRK 4406 OB	73	
	RP-17-144	RF-17,000	L1624	Prior to 11/93	FDRK 4405 OB	74	
	RP-17-144	RF-17,000	L1624	After 11/93	FDRK 4406 OB	74	
	RP-17-144	RF-17,000	P1888	Prior to 11/93	FDRK 4405 OB	74	
	RP-17-144	RF-17,000	P1888	After 11/93	FDRK 4406 OB	74	
	RP-17-144	RF-17,000	V1816	Prior to 11/93 w/Original 39 Spline Input	FDRK 217F OB	60	
	RP-17-144	RF-17,000	V1816	Prior to 11/93 w/ New 46 Spline Input	FDRK 4395 OB	73	
	RP-17-144	RF-17,000	V1816	After 11/93	FDRK 4396 OB	74	
	RP-17-144	RF-17,000	W1817	Prior to 11/93	FDRK 4405 OB	74	
	RP-17-144	RF-17,000	W1817	After 11/93	FDRK 4406 OB	74	
	RP-17-144	RF-17,000	X1662	Prior to 11/93 w/Original 39 Spline Input	FDRK 217F OB	60	
	RP-17-144	RF-17,000	X1662	Prior to 11/93 w/ New 46 Spline Input	FDRK 4395 OB	73	
	RP-17-144	RF-17,000	X1662	After 11/93	FDRK 4396 OB	74	
	RR-17-144	RR-17,000	D1850		FDRK 217R OB	60	
	RR-17-144	RR-17,000	E1851		FDRK 217R OB	60	
	RR-17-144	RR-17,000	G1879		FDRK 4390 OB	73	
	RR-17-144	RR-17,000	L1676		FDRK 217R OB	60	
	RR-17-144	RR-17,000	M1885		FDRK 217R OB	60	
	RR-17-144	RR-17,000	Q1785		FDRK 217R OB	60	
	RR-17-144	RR-17,000	S1865		FDRK 217R OB	60	
	RR-17-144	RR-17,000	X1558		FDRK 4390 OB	73	
	RT-34-145	RT-34,000	All		Prior to 11/93 w/Original 39 Spline Input	FDRK 217F OB	60
	RT-34-145	RD-17-145	RF-17,000	All	Prior to 11/93 w/ New 46 Spline Input	FDRK 4395 OB	73
		RD-17-145	RF-17,000	All	After 11/93	FDRK 4396 OB	74
		RP-17-145	RF-17,000	All	Prior to 11/93	FDRK 4395 OB	73
RP-17-145		RF-17,000	All	After 11/93	FDRK 4396 OB	74	
RR-17-145		RR-17,000	All		FDRK 217R OB	60	
RT-38-144	RD-19-144	RF-19,000	B1978	Prior to 11/93 w/Original 39 Spline Input	FDRK 217F OB	60	
	RD-19-144	RF-19,000	B1978	Prior to 11/93 w/ New 46 Spline Input	FDRK 4395 OB	73	
	RD-19-144	RF-19,000	B1978	After 11/93	FDRK 4396 OB	74	
	RD-19-144	RF-19,000	C1979	Prior to 11/93 w/Original 39 Spline Input	FDRK 217F OB	60	
	RD-19-144	RF-19,000	C1979	Prior to 11/93 w/ New 46 Spline Input	FDRK 4395 OB	73	
	RD-19-144	RF-19,000	C1979	After 11/93	FDRK 4396 OB	74	
	RD-19-144	RF-19,000	E1903	Prior to 11/93	FDRK 4405 OB	74	
	RD-19-144	RF-19,000	E1903	After 11/93	FDRK 4406 OB	74	
	RD-19-144	RF-19,000	E1981	Prior to 11/93	FDRK 4405 OB	74	
	RD-19-144	RF-19,000	E1981	After 11/93	FDRK 4406 OB	74	
	RD-19-144	RF-19,000	F1852	Prior to 11/93 w/Original 39 Spline Input	FDRK 217F OB	60	
	RD-19-144	RF-19,000	F1852	Prior to 11/93 w/ New 46 Spline Input	FDRK 4395 OB	73	
	RD-19-144	RF-19,000	F1852	After 11/93	FDRK 4396 OB	74	

Axle Model	Sub Model	Type/Cap.	Carrier	Notes	Fersa Bearing Kit	Pg.
Meritor						
140,141,143,144 & 145 Series Tandem Axle						
RT-38-144	RD-19-144	RF-19,000	G1645	Prior to 11/93 w/Original 39 Spline Input	FDRK 217F OB	60
	RD-19-144	RF-19,000	G1645	Prior to 11/93 w/ New 46 Spline Input	FDRK 4395 OB	73
	RD-19-144	RF-19,000	G1645	After 11/93	FDRK 4396 OB	74
	RD-19-144	RF-19,000	M1677	Prior to 11/93	FDRK 4405 OB	74
	RD-19-144	RF-19,000	M1677	After 11/93	FDRK 4406 OB	74
	RD-19-144	RF-19,000	N1860	Prior to 11/93 w/Original 39 Spline Input	FDRK 217F OB	60
	RD-19-144	RF-19,000	N1860	Prior to 11/93 w/ New 46 Spline Input	FDRK 4395 OB	73
	RD-19-144	RF-19,000	N1860	After 11/93	FDRK 4396 OB	74
	RD-19-144	RF-19,000	R1890	Prior to 11/93	FDRK 4405 OB	74
	RD-19-144	RF-19,000	R1890	After 11/93	FDRK 4406 OB	74
	RD-19-144	RF-19,000	S1917	Prior to 11/93 w/Original 39 Spline Input	FDRK 217F OB	60
	RD-19-144	RF-19,000	S1917	Prior to 11/93 w/ New 46 Spline Input	FDRK 4395 OB	73
	RD-19-144	RF-19,000	S1917	After 11/93	FDRK 4396 OB	74
	RD-19-144	RF-19,000	T1814	Prior to 11/93 w/Original 39 Spline Input	FDRK 217F OB	60
	RD-19-144	RF-19,000	T1814	Prior to 11/93 w/ New 46 Spline Input	FDRK 4395 OB	73
	RD-19-144	RF-19,000	T1814	After 11/93	FDRK 4396 OB	74
	RD-19-144	RF-19,000	U1815	Prior to 11/93	FDRK 4405 OB	74
	RD-19-144	RF-19,000	U1815	After 11/93	FDRK 4406 OB	74
	RP-19-144	RF-19,000	D1902	Prior to 11/93	FDRK 4405 OB	74
	RP-19-144	RF-19,000	D1902	After 11/93	FDRK 4406 OB	74
	RP-19-144	RF-19,000	G1853	Prior to 11/93 w/Original 39 Spline Input	FDRK 217F OB	60
	RP-19-144	RF-19,000	G1853	Prior to 11/93 w/ New 46 Spline Input	FDRK 4395 OB	73
	RP-19-144	RF-19,000	G1853	After 11/93	FDRK 4396 OB	74
	RP-19-144	RF-19,000	H1984	Prior to 11/93 w/Original 39 Spline Input	FDRK 217F OB	60
	RP-19-144	RF-19,000	H1984	Prior to 11/93 w/ New 46 Spline Input	FDRK 4395 OB	73
	RP-19-144	RF-19,000	H1984	After 11/93	FDRK 4396 OB	74
	RP-19-144	RF-19,000	K1987	Prior to 11/93	FDRK 4405 OB	74
	RP-19-144	RF-19,000	K1987	After 11/93	FDRK 4406 OB	74
	RP-19-144	RF-19,000	L1624	Prior to 11/93	FDRK 4405 OB	74
	RP-19-144	RF-19,000	L1624	After 11/93	FDRK 4406 OB	74
	RP-19-144	RF-19,000	P1888	Prior to 11/93	FDRK 4405 OB	74
	RP-19-144	RF-19,000	P1888	After 11/93	FDRK 4406 OB	74
	RP-19-144	RF-19,000	V1816	Prior to 11/93 w/Original 39 Spline Input	FDRK 217F OB	60
	RP-19-144	RF-19,000	V1816	Prior to 11/93 w/ New 46 Spline Input	FDRK 4395 OB	73
	RP-19-144	RF-19,000	V1816	After 11/93	FDRK 4396 OB	74
	RP-19-144	RF-19,000	W1817	Prior to 11/93	FDRK 4405 OB	74
	RP-19-144	RF-19,000	W1817	After 11/93	FDRK 4406 OB	74
	RP-19-144	RF-19,000	X1662	Prior to 11/93 w/Original 39 Spline Input	FDRK 217F OB	60
	RP-19-144	RF-19,000	X1662	Prior to 11/93 w/ New 46 Spline Input	FDRK 4395 OB	73
	RP-19-144	RF-19,000	X1662	After 11/93	FDRK 4396 OB	74
	RR-19-144	RR-19,000	D1850		FDRK 217R OB	60
	RR-19-144	RR-19,000	E1851		FDRK 217R OB	60
	RR-19-144	RR-19,000	G1879		FDRK 4390 OB	73
	RR-19-144	RR-19,000	L1676		FDRK 217R OB	60

1.1 \ Heavy Duty Differential Index

Axle Model	Sub Model	Type/Cap.	Carrier	Notes	Fersa Bearing Kit	Pg.
Meritor						
140,141,143,144 & 145 Series Tandem Axle						
RT-38-144	RR-19-144	RR-19,000	M1885		FDRK 217R OB	60
	RR-19-144	RR-19,000	Q1785		FDRK 217R OB	60
	RR-19-144	RR-19,000	S1865		FDRK 217R OB	60
	RR-19-144	RR-19,000	X1558		FDRK 4390 OB	73
RT-40-140	RD-20-140	RF-20,000	All	Prior to 11/93	FDRK 4355 OB	73
	RD-20-140	RF-20,000	All	After 11/93	FDRK 4356 OB	73
	RR-20-140	RR-20,000	All		FDRK 217R OB	60
MT-40-143	MD-20-143	RF-20,000	B1978	Prior to 11/93 w/Original 39 Spline Input	FDRK 217F OB	60
	MD-20-143	RF-20,000	B1978	Prior to 11/93 w/ New 46 Spline Input	FDRK 4395 OB	73
	MD-20-143	RF-20,000	B1978	After 11/93	FDRK 4396 OB	74
	MD-20-143	RF-20,000	C1979	Prior to 11/93 w/Original 39 Spline Input	FDRK 217F OB	60
	MD-20-143	RF-20,000	C1979	Prior to 11/93 w/ New 46 Spline Input	FDRK 4395 OB	73
	MD-20-143	RF-20,000	C1979	After 11/93	FDRK 4396 OB	74
	MD-20-143	RF-20,000	E1903	Prior to 11/93	FDRK 4405 OB	74
	MD-20-143	RF-20,000	E1903	After 11/93	FDRK 4406 OB	74
	MD-20-143	RF-20,000	E1981	Prior to 11/93	FDRK 4405 OB	74
	MD-20-143	RF-20,000	E1981	After 11/93	FDRK 4406 OB	74
	MD-20-143	RF-20,000	F1852	Prior to 11/93 w/Original 39 Spline Input	FDRK 217F OB	60
	MD-20-143	RF-20,000	F1852	Prior to 11/93 w/ New 46 Spline Input	FDRK 4395 OB	73
	MD-20-143	RF-20,000	F1852	After 11/93	FDRK 4396 OB	74
	MD-20-143	RF-20,000	G1645	Prior to 11/93 w/Original 39 Spline Input	FDRK 217F OB	60
	MD-20-143	RF-20,000	G1645	Prior to 11/93 w/ New 46 Spline Input	FDRK 4395 OB	73
	MD-20-143	RF-20,000	G1645	After 11/93	FDRK 4396 OB	74
	MD-20-143	RF-20,000	M1677	Prior to 11/93	FDRK 4405 OB	74
	MD-20-143	RF-20,000	M1677	After 11/93	FDRK 4406 OB	74
	MD-20-143	RF-20,000	N1860	Prior to 11/93 w/Original 39 Spline Input	FDRK 217F OB	60
	MD-20-143	RF-20,000	N1860	Prior to 11/93 w/ New 46 Spline Input	FDRK 4395 OB	73
	MD-20-143	RF-20,000	N1860	After 11/93	FDRK 4396 OB	74
	MD-20-143	RF-20,000	R1890	Prior to 11/93	FDRK 4405 OB	74
	MD-20-143	RF-20,000	R1890	After 11/93	FDRK 4406 OB	74
	MD-20-143	RF-20,000	S1917	Prior to 11/93 w/Original 39 Spline Input	FDRK 217F OB	60
	MD-20-143	RF-20,000	S1917	Prior to 11/93 w/ New 46 Spline Input	FDRK 4395 OB	73
	MD-20-143	RF-20,000	S1917	After 11/93	FDRK 4396 OB	74
	MD-20-143	RF-20,000	T1814	Prior to 11/93 w/Original 39 Spline Input	FDRK 217F OB	60
	MD-20-143	RF-20,000	T1814	Prior to 11/93 w/ New 46 Spline Input	FDRK 4395 OB	73
	MD-20-143	RF-20,000	T1814	After 11/93	FDRK 4396 OB	74
	MD-20-143	RF-20,000	U1815	Prior to 11/93	FDRK 4405 OB	74
	MD-20-143	RF-20,000	U1815	After 11/93	FDRK 4406 OB	74
	MP-20-143	RF-20,000	D1902	Prior to 11/93	FDRK 4405 OB	74
	MP-20-143	RF-20,000	D1902	After 11/93	FDRK 4406 OB	74
	MP-20-143	RF-20,000	G1853	Prior to 11/93 w/Original 39 Spline Input	FDRK 217F OB	60
	MP-20-143	RF-20,000	G1853	Prior to 11/93 w/ New 46 Spline Input	FDRK 4395 OB	73
	MP-20-143	RF-20,000	G1853	After 11/93	FDRK 4396 OB	74
	MP-20-143	RF-20,000	H1984	Prior to 11/93 w/Original 39 Spline Input	FDRK 217F OB	60

Axle Model	Sub Model	Type/Cap.	Carrier	Notes	Fersa Bearing Kit	Pg.	
Meritor							
140,141,143,144 & 145 Series Tandem Axle							
MT-40-143	MP-20-143	RF-20,000	H1984	Prior to 11/93 w/ New 46 Spline Input	FDRK 4395 OB	73	
	MP-20-143	RF-20,000	H1984	After 11/93	FDRK 4396 OB	74	
	MP-20-143	RF-20,000	K1987	Prior to 11/93	FDRK 4405 OB	74	
	MP-20-143	RF-20,000	K1987	After 11/93	FDRK 4406 OB	74	
	MP-20-143	RF-20,000	L1624	Prior to 11/93	FDRK 4405 OB	74	
	MP-20-143	RF-20,000	L1624	After 11/93	FDRK 4406 OB	74	
	MP-20-143	RF-20,000	P1888	Prior to 11/93	FDRK 4405 OB	74	
	MP-20-143	RF-20,000	P1888	After 11/93	FDRK 4406 OB	74	
	MP-20-143	RF-20,000	V1816	Prior to 11/93 w/Original 39 Spline Input	FDRK 217F OB	60	
	MP-20-143	RF-20,000	V1816	Prior to 11/93 w/ New 46 Spline Input	FDRK 4395 OB	73	
	MP-20-143	RF-20,000	V1816	After 11/93	FDRK 4396 OB	74	
	MP-20-143	RF-20,000	W1817	Prior to 11/93	FDRK 4405 OB	74	
	MP-20-143	RF-20,000	W1817	After 11/93	FDRK 4406 OB	74	
	MP-20-143	RF-20,000	X1662	Prior to 11/93 w/Original 39 Spline Input	FDRK 217F OB	60	
	MP-20-143	RF-20,000	X1662	Prior to 11/93 w/ New 46 Spline Input	FDRK 4395 OB	73	
	MP-20-143	RF-20,000	X1662	After 11/93	FDRK 4396 OB	74	
	MR-20-143	RR-20,000	All		FDRK 4461 OB	75	
	MR-20-143M	RR-20,000	All		FDRK 4461 OB	75	
	RT-40-145	RD-20-145	RF-20,000	B1978	Prior to 11/93 w/Original 39 Spline Input	FDRK 217F OB	60
		RD-20-145	RF-20,000	B1978	Prior to 11/93 w/ New 46 Spline Input	FDRK 4395 OB	73
RD-20-145		RF-20,000	B1978	After 11/93	FDRK 4396 OB	74	
RD-20-145		RF-20,000	C1979	Prior to 11/93 w/Original 39 Spline Input	FDRK 217F OB	60	
RD-20-145		RF-20,000	C1979	Prior to 11/93 w/ New 46 Spline Input	FDRK 4395 OB	73	
RD-20-145		RF-20,000	C1979	After 11/93	FDRK 4396 OB	74	
RD-20-145		RF-20,000	E1903	Prior to 11/93	FDRK 4405 OB	74	
RD-20-145		RF-20,000	E1903	After 11/93	FDRK 4406 OB	74	
RD-20-145		RF-20,000	E1981	Prior to 11/93	FDRK 4405 OB	74	
RD-20-145		RF-20,000	E1981	After 11/93	FDRK 4406 OB	74	
RD-20-145		RF-20,000	F1852	Prior to 11/93 w/Original 39 Spline Input	FDRK 217F OB	60	
RD-20-145		RF-20,000	F1852	Prior to 11/93 w/ New 46 Spline Input	FDRK 4395 OB	73	
RD-20-145		RF-20,000	F1852	After 11/93	FDRK 4396 OB	74	
RD-20-145		RF-20,000	G1645	Prior to 11/93 w/Original 39 Spline Input	FDRK 217F OB	60	
RD-20-145		RF-20,000	G1645	Prior to 11/93 w/ New 46 Spline Input	FDRK 4395 OB	73	
RD-20-145		RF-20,000	G1645	After 11/93	FDRK 4396 OB	74	
RD-20-145		RF-20,000	M1677	Prior to 11/93	FDRK 4405 OB	74	
RD-20-145		RF-20,000	M1677	After 11/93	FDRK 4406 OB	74	
RD-20-145		RF-20,000	N1860	Prior to 11/93 w/Original 39 Spline Input	FDRK 217F OB	60	
RD-20-145		RF-20,000	N1860	Prior to 11/93 w/ New 46 Spline Input	FDRK 4395 OB	73	
RD-20-145		RF-20,000	N1860	After 11/93	FDRK 4396 OB	74	
RD-20-145		RF-20,000	R1890	Prior to 11/93	FDRK 4405 OB	74	
RD-20-145		RF-20,000	R1890	After 11/93	FDRK 4406 OB	74	
RD-20-145		RF-20,000	S1917	Prior to 11/93 w/Original 39 Spline Input	FDRK 217F OB	60	
RD-20-145		RF-20,000	S1917	Prior to 11/93 w/ New 46 Spline Input	FDRK 4395 OB	73	
RD-20-145		RF-20,000	S1917	After 11/93	FDRK 4396 OB	74	
RD-20-145		RF-20,000	T1814	Prior to 11/93 w/Original 39 Spline Input	FDRK 217F OB	60	

1.1 \ Heavy Duty Differential Index

Axle Model	Sub Model	Type/Cap.	Carrier	Notes	Fersa Bearing Kit	Pg.
Meritor						
140,141,143,144 & 145 Series Tandem Axle						
RT-40-145	RD-20-145	RF-20,000	T1814	Prior to 11/93 w/ New 46 Spline Input	FDRK 4395 OB	73
	RD-20-145	RF-20,000	T1814	After 11/93	FDRK 4396 OB	74
	RD-20-145	RF-20,000	U1815	Prior to 11/93	FDRK 4405 OB	74
	RD-20-145	RF-20,000	U1815	After 11/93	FDRK 4406 OB	74
	RP-20-145	RF-20,000	D1902	Prior to 11/93	FDRK 4405 OB	74
	RP-20-145	RF-20,000	D1902	After 11/93	FDRK 4406 OB	74
	RP-20-145	RF-20,000	G1853	Prior to 11/93 w/Original 39 Spline Input	FDRK 217F OB	60
	RP-20-145	RF-20,000	G1853	Prior to 11/93 w/ New 46 Spline Input	FDRK 4395 OB	73
	RP-20-145	RF-20,000	G1853	After 11/93	FDRK 4396 OB	74
	RP-20-145	RF-20,000	H1984	Prior to 11/93 w/Original 39 Spline Input	FDRK 217F OB	60
	RP-20-145	RF-20,000	H1984	Prior to 11/93 w/ New 46 Spline Input	FDRK 4395 OB	73
	RP-20-145	RF-20,000	H1984	After 11/93	FDRK 4396 OB	74
	RP-20-145	RF-20,000	K1987	Prior to 11/93	FDRK 4405 OB	74
	RP-20-145	RF-20,000	K1987	After 11/93	FDRK 4406 OB	74
	RP-20-145	RF-20,000	L1624	Prior to 11/93	FDRK 4405 OB	74
	RP-20-145	RF-20,000	L1624	After 11/93	FDRK 4406 OB	74
	RP-20-145	RF-20,000	P1888	Prior to 11/93	FDRK 4405 OB	74
	RP-20-145	RF-20,000	P1888	After 11/93	FDRK 4406 OB	74
	RP-20-145	RF-20,000	V1816	Prior to 11/93 w/Original 39 Spline Input	FDRK 217F OB	60
	RP-20-145	RF-20,000	V1816	Prior to 11/93 w/ New 46 Spline Input	FDRK 4395 OB	73
	RP-20-145	RF-20,000	V1816	After 11/93	FDRK 4396 OB	74
	RP-20-145	RF-20,000	W1817	Prior to 11/93	FDRK 4405 OB	74
	RP-20-145	RF-20,000	W1817	After 11/93	FDRK 4406 OB	74
	RP-20-145	RF-20,000	X1662	Prior to 11/93 w/Original 39 Spline Input	FDRK 217F OB	60
	RP-20-145	RF-20,000	X1662	Prior to 11/93 w/ New 46 Spline Input	FDRK 4395 OB	73
	RP-20-145	RF-20,000	X1662	After 11/93	FDRK 4396 OB	74
	RR-20-145	RR-20,000	D1850		FDRK 217R OB	60
	RR-20-145	RR-20,000	E1851		FDRK 217R OB	60
	RR-20-145	RR-20,000	G1879		FDRK 4390 OB	73
	RR-20-145	RR-20,000	L1676		FDRK 217R OB	60
	RR-20-145	RR-20,000	M1885		FDRK 217R OB	60
	RR-20-145	RR-20,000	Q1785		FDRK 217R OB	60
	RR-20-145	RR-20,000	S1865		FDRK 217R OB	60
	RR-20-145	RR-20,000	X1558		FDRK 4390 OB	73
RT-44-145	RD-22-145	RF-22,000	B1874	Prior to 11/93 w/Original 39 Spline Input	FDRK 217F OB	60
	RD-22-145	RF-22,000	B1874	Prior to 11/93 w/ New 46 Spline Input	FDRK 4395 OB	73
	RD-22-145	RF-22,000	B1874	After 11/93	FDRK 4396 OB	74
	RD-22-145	RF-22,000	C1875	Prior to 11/93	FDRK 4405 OB	74
	RD-22-145	RF-22,000	C1875	After 11/93	FDRK 4406 OB	74
	RD-22-145	RF-22,000	D1980	Prior to 11/93 w/Original 39 Spline Input	FDRK 217F OB	60
	RD-22-145	RF-22,000	D1980	Prior to 11/93 w/ New 46 Spline Input	FDRK 4395 OB	73
	RD-22-145	RF-22,000	D1980	After 11/93	FDRK 4396 OB	74
	RD-22-145	RF-22,000	F1982	Prior to 11/93	FDRK 4405 OB	74
	RD-22-145	RF-22,000	F1982	After 11/93	FDRK 4406 OB	74
	RD-22-145	RF-22,000	G1905	Prior to 11/93	FDRK 4405 OB	74
	RD-22-145	RF-22,000	G1905	After 11/93	FDRK 4406 OB	74

Axle Model	Sub Model	Type/Cap.	Carrier	Notes	Fersa Bearing Kit	Pg.
Meritor						
140,141,143,144 & 145 Series Tandem Axle						
RT-44-145	RP-22-145	RF-22,000	D1876	Prior to 11/93 w/Original 39 Spline Input	FDRK 217F OB	60
	RP-22-145	RF-22,000	D1876	Prior to 11/93 w/ New 46 Spline Input	FDRK 4395 OB	73
	RP-22-145	RF-22,000	D1876	After 11/93	FDRK 4396 OB	74
	RP-22-145	RF-22,000	E1877	Prior to 11/93	FDRK 4405 OB	74
	RP-22-145	RF-22,000	E1877	After 11/93	FDRK 4406 OB	74
	RP-22-145	RF-22,000	H1906	Prior to 11/93	FDRK 4405 OB	74
	RP-22-145	RF-22,000	H1906	After 11/93	FDRK 4406 OB	74
	RP-22-145	RF-22,000	J1986	Prior to 11/93 w/Original 39 Spline Input	FDRK 217F OB	60
	RP-22-145	RF-22,000	J1986	Prior to 11/93 w/ New 46 Spline Input	FDRK 4395 OB	73
	RP-22-145	RF-22,000	J1986	After 11/93	FDRK 4396 OB	74
	RP-22-145	RF-22,000	M1911	Prior to 11/93	FDRK 4405 OB	74
	RP-22-145	RF-22,000	M1911	After 11/93	FDRK 4406 OB	74
	RP-22-145	RF-22,000	P1914	Prior to 11/93 w/Original 39 Spline Input	FDRK 217F OB	60
	RP-22-145	RF-22,000	P1914	Prior to 11/93 w/ New 46 Spline Input	FDRK 4395 OB	73
	RP-22-145	RF-22,000	P1914	After 11/93	FDRK 4396 OB	74
	RP-22-145	RF-22,000	T1918	Prior to 11/93	FDRK 4405 OB	74
	RP-22-145	RF-22,000	T1918	After 11/93	FDRK 4406 OB	74
	RR-22-145	RR-22,000	A1873		FDRK 217R OB	60
	RR-22-145	RR-22,000	F1904		FDRK 4390 OB	73

160, 161 & 164 Series Single Axles						
RC-23-160		R-23,000	A1821		FDRK 4426 OB	74
		R-23,000	C1511		FDRK 4415 OB	74
		R-23,000	C1823		FDRK 4428 OB	74
		R-23,000	D1928		FDRK 4428 OB	74
		R-23,000	E1825		FDRK 4428 OB	74
		R-23,000	E1929		FDRK 4428 OB	74
		R-23,000	H1854		FDRK 4426 OB	74
		R-23,000	J1856		FDRK 4426 OB	74
		R-23,000	P1706		FDRK 4426 OB	74
		R-23,000	R1708		FDRK 4428 OB	74
		R-23,000	T1658		FDRK 4415 OB	74
		R-23,000	T1892		FDRK 4428 OB	74
		R-23,000	V1660		FDRK 4415 OB	74
		R-23,000	V1712		FDRK 4428 OB	74
		R-23,000	Y1897		FDRK 4428 OB	74
		R-23,000	Z1560		FDRK 4415 OB	74
RS-20-160		R-20,000	A1821		FDRK 4426 OB	74
		R-20,000	C1511		FDRK 4415 OB	74
		R-20,000	C1823		FDRK 4428 OB	74
		R-20,000	D1928		FDRK 4428 OB	74
		R-20,000	E1825		FDRK 4428 OB	74
		R-20,000	E1929		FDRK 4428 OB	74
		R-20,000	H1854		FDRK 4426 OB	74
		R-20,000	J1856		FDRK 4426 OB	74
		R-20,000	P1706		FDRK 4426 OB	74
		R-20,000	R1708		FDRK 4428 OB	74
		R-20,000	T1658		FDRK 4415 OB	74
		R-20,000	T1892		FDRK 4428 OB	74
		R-20,000	V1660		FDRK 4415 OB	74

1.1 \ Heavy Duty Differential Index

Axle Model	Sub Model	Type/Cap.	Carrier	Notes	Fersa Bearing Kit	Pg.
Meritor						
160, 161 & 164 Series Single Axles						
RS-20-160		R-20,000	V1712		FDRK 4428 OB	74
		R-20,000	Y1897		FDRK 4428 OB	74
		R-20,000	Z1560		FDRK 4415 OB	74
RS-21-160		R-21,000	A1821		FDRK 4426 OB	74
		R-21,000	C1511		FDRK 4415 OB	74
		R-21,000	C1823		FDRK 4428 OB	74
		R-21,000	D1928		FDRK 4428 OB	74
		R-21,000	E1825		FDRK 4428 OB	74
		R-21,000	E1929		FDRK 4428 OB	74
		R-21,000	H1854		FDRK 4426 OB	74
		R-21,000	J1856		FDRK 4426 OB	74
		R-21,000	P1706		FDRK 4426 OB	74
		R-21,000	R1708		FDRK 4428 OB	74
		R-21,000	T1658		FDRK 4415 OB	74
		R-21,000	T1892		FDRK 4428 OB	74
		R-21,000	V1660		FDRK 4415 OB	74
		R-21,000	V1712		FDRK 4428 OB	74
		R-21,000	Y1897		FDRK 4428 OB	74
	R-21,000	Z1560		FDRK 4415 OB	74	
RS-23-160		R-23,000	A1821		FDRK 4426 OB	74
		R-23,000	C1511		FDRK 4415 OB	74
		R-23,000	C1823		FDRK 4428 OB	74
		R-23,000	D1928		FDRK 4428 OB	74
		R-23,000	E1825		FDRK 4428 OB	74
		R-23,000	E1929		FDRK 4428 OB	74
		R-23,000	H1854		FDRK 4426 OB	74
		R-23,000	J1856		FDRK 4426 OB	74
		R-23,000	P1706		FDRK 4426 OB	74
		R-23,000	R1708		FDRK 4428 OB	74
		R-23,000	T1658		FDRK 4415 OB	74
		R-23,000	T1892		FDRK 4428 OB	74
		R-23,000	V1660		FDRK 4415 OB	74
		R-23,000	V1712		FDRK 4428 OB	74
		R-23,000	Y1897		FDRK 4428 OB	74
	R-23,000	Z1560		FDRK 4415 OB	74	
RS-23-161		R-23,000	A1821		FDRK 4426 OB	74
		R-23,000	C1511		FDRK 4415 OB	74
		R-23,000	C1823		FDRK 4428 OB	74
		R-23,000	D1928		FDRK 4428 OB	74
		R-23,000	E1825		FDRK 4428 OB	74
		R-23,000	E1929		FDRK 4428 OB	74
		R-23,000	H1854		FDRK 4426 OB	74
		R-23,000	J1856		FDRK 4426 OB	74
		R-23,000	P1706		FDRK 4426 OB	74
		R-23,000	R1708		FDRK 4428 OB	74
		R-23,000	T1658		FDRK 4415 OB	74
		R-23,000	T1892		FDRK 4428 OB	74
		R-23,000	V1660		FDRK 4415 OB	74
		R-23,000	V1712		FDRK 4428 OB	74
		R-23,000	Y1897		FDRK 4428 OB	74
	R-23,000	Z1560		FDRK 4415 OB	74	

Axle Model	Sub Model	Type/Cap.	Carrier	Notes	Fersa Bearing Kit	Pg.
Meritor						
160, 161 & 164 Series Single Axles						
RS-24-160		R-24,000	A1821		FDRK 4426 OB	74
		R-24,000	C1511		FDRK 4415 OB	74
		R-24,000	C1823		FDRK 4428 OB	74
		R-24,000	D1928		FDRK 4428 OB	74
		R-24,000	E1825		FDRK 4428 OB	74
		R-24,000	E1929		FDRK 4428 OB	74
		R-24,000	H1854		FDRK 4426 OB	74
		R-24,000	J1856		FDRK 4426 OB	74
		R-24,000	P1706		FDRK 4426 OB	74
		R-24,000	R1708		FDRK 4428 OB	74
		R-24,000	T1658		FDRK 4415 OB	74
		R-24,000	T1892		FDRK 4428 OB	74
		R-24,000	V1660		FDRK 4415 OB	74
		R-24,000	V1712		FDRK 4428 OB	74
		R-24,000	Y1897		FDRK 4428 OB	74
		R-24,000	Z1560		FDRK 4415 OB	74
RS-25-160		R-25,000	A1821		FDRK 4426 OB	74
		R-25,000	C1511		FDRK 4415 OB	74
		R-25,000	C1823		FDRK 4428 OB	74
		R-25,000	D1928		FDRK 4428 OB	74
		R-25,000	E1825		FDRK 4428 OB	74
		R-25,000	E1929		FDRK 4428 OB	74
		R-25,000	H1854		FDRK 4426 OB	74
		R-25,000	J1856		FDRK 4426 OB	74
		R-25,000	P1706		FDRK 4426 OB	74
		R-25,000	R1708		FDRK 4428 OB	74
		R-25,000	T1658		FDRK 4415 OB	74
		R-25,000	T1892		FDRK 4428 OB	74
		R-25,000	V1660		FDRK 4415 OB	74
		R-25,000	V1712		FDRK 4428 OB	74
		R-25,000	Y1897		FDRK 4428 OB	74
		R-25,000	Z1560		FDRK 4415 OB	74
RS-26-160		R-26,000	A1821		FDRK 4426 OB	74
		R-26,000	C1511		FDRK 4415 OB	74
		R-26,000	C1823		FDRK 4428 OB	74
		R-26,000	D1928		FDRK 4428 OB	74
		R-26,000	E1825		FDRK 4428 OB	74
		R-26,000	E1929		FDRK 4428 OB	74
		R-26,000	H1854		FDRK 4426 OB	74
		R-26,000	J1856		FDRK 4426 OB	74
		R-26,000	P1706		FDRK 4426 OB	74
		R-26,000	R1708		FDRK 4428 OB	74
		R-26,000	T1658		FDRK 4415 OB	74
		R-26,000	T1892		FDRK 4428 OB	74
		R-26,000	V1660		FDRK 4415 OB	74
		R-26,000	V1712		FDRK 4428 OB	74
		R-26,000	Y1897		FDRK 4428 OB	74
		R-26,000	Z1560		FDRK 4415 OB	74

1.1 \ Heavy Duty Differential Index

Axle Model	Sub Model	Type/Cap.	Carrier	Notes	Fersa Bearing Kit	Pg.
Meritor						
160, 161 & 164 Series Tandem Axles						
RT-40-160	RD-20-160	RF-20,000	J1648		FDRK 4420 OB	74
	RD-20-160	RF-20,000	J2116		FDRK 4422 OB	74
	RD-20-160	RF-20,000	K1857		FDRK 4422 OB	74
	RD-20-160	RF-20,000	L2118		FDRK 4423 OB	74
	RD-20-160	RF-20,000	M1703		FDRK 4422 OB	74
	RD-20-160	RF-20,000	P1628		FDRK 4420 OB	74
	RD-20-160	RF-20,000	Q1837		FDRK 4422 OB	74
	RD-20-160	RF-20,000	W1713		FDRK 4423 OB	74
	RD-20-160	RF-20,000	W1895		FDRK 4423 OB	74
	RD-20-160	RF-20,000	X1818		FDRK 4422 OB	74
	RD-20-160	RF-20,000	Y1819		FDRK 4423 OB	74
	RP-20-160	RF-20,000	K1701		FDRK 4423 OB	74
	RP-20-160	RF-20,000	K2117		FDRK 4423 OB	74
	RP-20-160	RF-20,000	V1894		FDRK 4423 OB	74
	RP-20-160	RF-20,000	Z1820		FDRK 4423 OB	74
	RR-20-160	RR-20,000	A1821		FDRK 4426 OB	74
	RR-20-160	RR-20,000	C1511		FDRK 4415 OB	74
	RR-20-160	RR-20,000	C1823		FDRK 4428 OB	74
	RR-20-160	RR-20,000	D1928		FDRK 4428 OB	74
	RR-20-160	RR-20,000	E1825		FDRK 4428 OB	74
	RR-20-160	RR-20,000	E1929		FDRK 4428 OB	74
	RR-20-160	RR-20,000	H1854		FDRK 4426 OB	74
	RR-20-160	RR-20,000	J1856		FDRK 4426 OB	74
	RR-20-160	RR-20,000	P1706		FDRK 4426 OB	74
	RR-20-160	RR-20,000	R1708		FDRK 4428 OB	74
	RR-20-160	RR-20,000	T1658		FDRK 4415 OB	74
	RR-20-160	RR-20,000	T1892		FDRK 4428 OB	74
	RR-20-160	RR-20,000	V1660		FDRK 4415 OB	74
	RR-20-160	RR-20,000	V1712		FDRK 4428 OB	74
	RR-20-160	RR-20,000	Y1897		FDRK 4428 OB	74
	RR-20-160	RR-20,000	Z1560		FDRK 4415 OB	74
	RT-46-160	RD-23-160	RF-23,000	J1648		FDRK 4420 OB
RD-23-160		RF-23,000	J2116		FDRK 4422 OB	74
RD-23-160		RF-23,000	K1857		FDRK 4422 OB	74
RD-23-160		RF-23,000	L2118		FDRK 4423 OB	74
RD-23-160		RF-23,000	M1703		FDRK 4422 OB	74
RD-23-160		RF-23,000	P1628		FDRK 4420 OB	74
RD-23-160		RF-23,000	Q1837		FDRK 4422 OB	74
RD-23-160		RF-23,000	W1713		FDRK 4423 OB	74
RD-23-160		RF-23,000	W1895		FDRK 4423 OB	74
RD-23-160		RF-23,000	X1818		FDRK 4422 OB	74
RD-23-160		RF-23,000	Y1819		FDRK 4423 OB	74
RP-23-160		RF-23,000	K1701		FDRK 4423 OB	74
RP-23-160		RF-23,000	K2117		FDRK 4423 OB	74
RP-23-160		RF-23,000	V1894		FDRK 4423 OB	74
RP-23-160		RF-23,000	Z1820		FDRK 4423 OB	74
RR-23-160		RR-23,000	A1821		FDRK 4426 OB	74
RR-23-160		RR-23,000	C1511		FDRK 4415 OB	74
RR-23-160		RR-23,000	C1823		FDRK 4428 OB	74
RR-23-160		RR-23,000	D1928		FDRK 4428 OB	74
RR-23-160		RR-23,000	E1825		FDRK 4428 OB	74
RR-23-160		RR-23,000	E1929		FDRK 4428 OB	74

Axle Model	Sub Model	Type/Cap.	Carrier	Notes	Fersa Bearing Kit	Pg.
Meritor						
160, 161 & 164 Series Tandem Axles						
RT-46-160	RR-23-160	RR-23,000	H1854		FDRK 4426 OB	74
	RR-23-160	RR-23,000	J1856		FDRK 4426 OB	74
	RR-23-160	RR-23,000	P1706		FDRK 4426 OB	74
	RR-23-160	RR-23,000	R1708		FDRK 4428 OB	74
	RR-23-160	RR-23,000	T1658		FDRK 4415 OB	74
	RR-23-160	RR-23,000	T1892		FDRK 4428 OB	74
	RR-23-160	RR-23,000	V1660		FDRK 4415 OB	74
	RR-23-160	RR-23,000	V1712		FDRK 4428 OB	74
	RR-23-160	RR-23,000	Y1897		FDRK 4428 OB	74
RR-23-160	RR-23,000	Z1560		FDRK 4415 OB	74	
RT-46-164	RD-23-164	RF-23,000	J1648		FDRK 4420 OB	74
	RD-23-164	RF-23,000	J2116		FDRK 4422 OB	74
	RD-23-164	RF-23,000	K1857		FDRK 4422 OB	74
	RD-23-164	RF-23,000	L2118		FDRK 4423 OB	74
	RD-23-164	RF-23,000	M1703		FDRK 4422 OB	74
	RD-23-164	RF-23,000	P1628		FDRK 4420 OB	74
	RD-23-164	RF-23,000	Q1837		FDRK 4422 OB	74
	RD-23-164	RF-23,000	W1713		FDRK 4423 OB	74
	RD-23-164	RF-23,000	W1895		FDRK 4423 OB	74
	RD-23-164	RF-23,000	X1818		FDRK 4422 OB	74
	RD-23-164	RF-23,000	Y1819		FDRK 4423 OB	74
	RP-23-164	RF-23,000	K1701		FDRK 4423 OB	74
	RP-23-164	RF-23,000	K2117		FDRK 4423 OB	74
	RP-23-164	RF-23,000	V1894		FDRK 4423 OB	74
	RP-23-164	RF-23,000	Z1820		FDRK 4423 OB	74
	RR-23-164	RR-23,000	A1821		FDRK 4426 OB	74
	RR-23-164	RR-23,000	C1511		FDRK 4415 OB	74
	RR-23-164	RR-23,000	C1823		FDRK 4428 OB	74
	RR-23-164	RR-23,000	D1928		FDRK 4428 OB	74
	RR-23-164	RR-23,000	E1825		FDRK 4428 OB	74
	RR-23-164	RR-23,000	E1929		FDRK 4428 OB	74
	RR-23-164	RR-23,000	H1854		FDRK 4426 OB	74
	RR-23-164	RR-23,000	J1856		FDRK 4426 OB	74
	RR-23-164	RR-23,000	P1706		FDRK 4426 OB	74
	RR-23-164	RR-23,000	R1708		FDRK 4428 OB	74
	RR-23-164	RR-23,000	T1658		FDRK 4415 OB	74
	RR-23-164	RR-23,000	T1892		FDRK 4428 OB	74
	RR-23-164	RR-23,000	V1660		FDRK 4415 OB	74
	RR-23-164	RR-23,000	V1712		FDRK 4428 OB	74
	RR-23-164	RR-23,000	Y1897		FDRK 4428 OB	74
RR-23-164	RR-23,000	Z1560		FDRK 4415 OB	74	
RT-50-160	RD-25-160	RF-25,000	J1648		FDRK 4420 OB	74
	RD-25-160	RF-25,000	J2116		FDRK 4422 OB	74
	RD-25-160	RF-25,000	K1857		FDRK 4422 OB	74
	RD-25-160	RF-25,000	L2118		FDRK 4423 OB	74
	RD-25-160	RF-25,000	M1703		FDRK 4422 OB	74
	RD-25-160	RF-25,000	P1628		FDRK 4420 OB	74
	RD-25-160	RF-25,000	Q1837		FDRK 4422 OB	74
	RD-25-160	RF-25,000	W1713		FDRK 4423 OB	74
	RD-25-160	RF-25,000	W1895		FDRK 4423 OB	74
	RD-25-160	RF-25,000	X1818		FDRK 4422 OB	74
	RD-25-160	RF-25,000	Y1819		FDRK 4423 OB	74

1.1 \ Heavy Duty Differential Index

Axle Model	Sub Model	Type/Cap.	Carrier	Notes	Fersa Bearing Kit	Pg.
Meritor						
160, 161 & 164 Series Tandem Axles						
RT-50-160	RP-25-160	RF-25,000	K1701		FDRK 4423 OB	74
	RP-25-160	RF-25,000	K2117		FDRK 4423 OB	74
	RP-25-160	RF-25,000	V1894		FDRK 4423 OB	74
	RP-25-160	RF-25,000	Z1820		FDRK 4423 OB	74
	RR-25-160	RR-25,000	A1821		FDRK 4426 OB	74
	RR-25-160	RR-25,000	C1511		FDRK 4415 OB	74
	RR-25-160	RR-25,000	C1823		FDRK 4428 OB	74
	RR-25-160	RR-25,000	D1928		FDRK 4428 OB	74
	RR-25-160	RR-25,000	E1825		FDRK 4428 OB	74
	RR-25-160	RR-25,000	E1929		FDRK 4428 OB	74
	RR-25-160	RR-25,000	H1854		FDRK 4426 OB	74
	RR-25-160	RR-25,000	J1856		FDRK 4426 OB	74
	RR-25-160	RR-25,000	P1706		FDRK 4426 OB	74
	RR-25-160	RR-25,000	R1708		FDRK 4428 OB	74
	RR-25-160	RR-25,000	T1658		FDRK 4415 OB	74
	RR-25-160	RR-25,000	T1892		FDRK 4428 OB	74
	RR-25-160	RR-25,000	V1660		FDRK 4415 OB	74
	RR-25-160	RR-25,000	V1712		FDRK 4428 OB	74
	RR-25-160	RR-25,000	Y1897		FDRK 4428 OB	74
	RR-25-160	RR-25,000	Z1560		FDRK 4415 OB	74
RT-50-164	RD-25-164	RF-25,000	J1648		FDRK 4420 OB	74
	RD-25-164	RF-25,000	J2116		FDRK 4422 OB	74
	RD-25-164	RF-25,000	K1857		FDRK 4422 OB	74
	RD-25-164	RF-25,000	L2118		FDRK 4423 OB	74
	RD-25-164	RF-25,000	M1703		FDRK 4422 OB	74
	RD-25-164	RF-25,000	P1628		FDRK 4420 OB	74
	RD-25-164	RF-25,000	Q1837		FDRK 4422 OB	74
	RD-25-164	RF-25,000	W1713		FDRK 4423 OB	74
	RD-25-164	RF-25,000	W1895		FDRK 4423 OB	74
	RD-25-164	RF-25,000	X1818		FDRK 4422 OB	74
	RD-25-164	RF-25,000	Y1819		FDRK 4423 OB	74
	RP-25-164	RF-25,000	K1701		FDRK 4423 OB	74
	RP-25-164	RF-25,000	K2117		FDRK 4423 OB	74
	RP-25-164	RF-25,000	V1894		FDRK 4423 OB	74
	RP-25-164	RF-25,000	Z1820		FDRK 4423 OB	74
	RR-25-164	RR-25,000	A1821		FDRK 4426 OB	74
	RR-25-164	RR-25,000	C1511		FDRK 4415 OB	74
	RR-25-164	RR-25,000	C1823		FDRK 4428 OB	74
	RR-25-164	RR-25,000	D1928		FDRK 4428 OB	74
	RR-25-164	RR-25,000	E1825		FDRK 4428 OB	74
	RR-25-164	RR-25,000	E1929		FDRK 4428 OB	74
	RR-25-164	RR-25,000	H1854		FDRK 4426 OB	74
	RR-25-164	RR-25,000	J1856		FDRK 4426 OB	74
	RR-25-164	RR-25,000	P1706		FDRK 4426 OB	74
	RR-25-164	RR-25,000	R1708		FDRK 4428 OB	74
	RR-25-164	RR-25,000	T1658		FDRK 4415 OB	74
	RR-25-164	RR-25,000	T1892		FDRK 4428 OB	74
	RR-25-164	RR-25,000	V1660		FDRK 4415 OB	74
	RR-25-164	RR-25,000	V1712		FDRK 4428 OB	74
	RR-25-164	RR-25,000	Y1897		FDRK 4428 OB	74
	RR-25-164	RR-25,000	Z1560		FDRK 4415 OB	74

Axle Model	Sub Model	Type/Cap.	Carrier	Notes	Fersa Bearing Kit	Pg.
------------	-----------	-----------	---------	-------	-------------------	-----

Meritor

160, 161 & 164 Series Tandem Axles

RT-52-160	RD-26-160	RF-26,000	J1648		FDRK 4420 OB	74
	RD-26-160	RF-26,000	J2116		FDRK 4422 OB	74
	RD-26-160	RF-26,000	K1857		FDRK 4422 OB	74
	RD-26-160	RF-26,000	L2118		FDRK 4423 OB	74
	RD-26-160	RF-26,000	M1703		FDRK 4422 OB	74
	RD-26-160	RF-26,000	P1628		FDRK 4420 OB	74
	RD-26-160	RF-26,000	Q1837		FDRK 4422 OB	74
	RD-26-160	RF-26,000	W1713		FDRK 4423 OB	74
	RD-26-160	RF-26,000	W1895		FDRK 4423 OB	74
	RD-26-160	RF-26,000	X1818		FDRK 4422 OB	74
	RD-26-160	RF-26,000	Y1819		FDRK 4423 OB	74
	RP-26-160	RF-26,000	K1701		FDRK 4423 OB	74
	RP-26-160	RF-26,000	K2117		FDRK 4423 OB	74
	RP-26-160	RF-26,000	V1894		FDRK 4423 OB	74
	RP-26-160	RF-26,000	Z1820		FDRK 4423 OB	74
	RR-26-160	RR-26,000	A1821		FDRK 4426 OB	74
	RR-26-160	RR-26,000	C1511		FDRK 4415 OB	74
	RR-26-160	RR-26,000	C1823		FDRK 4428 OB	74
	RR-26-160	RR-26,000	D1928		FDRK 4428 OB	74
	RR-26-160	RR-26,000	E1825		FDRK 4428 OB	74
	RR-26-160	RR-26,000	E1929		FDRK 4428 OB	74
	RR-26-160	RR-26,000	H1854		FDRK 4426 OB	74
	RR-26-160	RR-26,000	J1856		FDRK 4426 OB	74
	RR-26-160	RR-26,000	P1706		FDRK 4426 OB	74
	RR-26-160	RR-26,000	R1708		FDRK 4428 OB	74
	RR-26-160	RR-26,000	T1658		FDRK 4415 OB	74
	RR-26-160	RR-26,000	T1892		FDRK 4428 OB	74
	RR-26-160	RR-26,000	V1660		FDRK 4415 OB	74
	RR-26-160	RR-26,000	V1712		FDRK 4428 OB	74
	RR-26-160	RR-26,000	Y1897		FDRK 4428 OB	74
RR-26-160	RR-26,000	Z1560		FDRK 4415 OB	74	
RT-52-164	RD-26-164	RF-26,000	J1648		FDRK 4420 OB	74
	RD-26-164	RF-26,000	J2116		FDRK 4422 OB	74
	RD-26-164	RF-26,000	K1857		FDRK 4422 OB	74
	RD-26-164	RF-26,000	L2118		FDRK 4423 OB	74
	RD-26-164	RF-26,000	M1703		FDRK 4422 OB	74
	RD-26-164	RF-26,000	P1628		FDRK 4420 OB	74
	RD-26-164	RF-26,000	Q1837		FDRK 4422 OB	74
	RD-26-164	RF-26,000	W1713		FDRK 4423 OB	74
	RD-26-164	RF-26,000	W1895		FDRK 4423 OB	74
	RD-26-164	RF-26,000	X1818		FDRK 4422 OB	74
	RD-26-164	RF-26,000	Y1819		FDRK 4423 OB	74
	RP-26-164	RF-26,000	K1701		FDRK 4423 OB	74
	RP-26-164	RF-26,000	K2117		FDRK 4423 OB	74
	RP-26-164	RF-26,000	V1894		FDRK 4423 OB	74
	RP-26-164	RF-26,000	Z1820		FDRK 4423 OB	74
	RR-26-164	RR-26,000	A1821		FDRK 4426 OB	74
	RR-26-164	RR-26,000	C1511		FDRK 4415 OB	74
	RR-26-164	RR-26,000	C1823		FDRK 4428 OB	74
	RR-26-164	RR-26,000	D1928		FDRK 4428 OB	74
	RR-26-164	RR-26,000	E1825		FDRK 4428 OB	74
	RR-26-164	RR-26,000	E1929		FDRK 4428 OB	74

1.1 \ Heavy Duty Differential Index

Axle Model	Sub Model	Type/Cap.	Carrier	Notes	Fersa Bearing Kit	Pg.
Meritor						
160, 161 & 164 Series Tandem Axles						
RT-52-164	RR-26-164	RR-26,000	H1854		FDRK 4426 OB	74
	RR-26-164	RR-26,000	J1856		FDRK 4426 OB	74
	RR-26-164	RR-26,000	P1706		FDRK 4426 OB	74
	RR-26-164	RR-26,000	R1708		FDRK 4428 OB	74
	RR-26-164	RR-26,000	T1658		FDRK 4415 OB	74
	RR-26-164	RR-26,000	T1892		FDRK 4428 OB	74
	RR-26-164	RR-26,000	V1660		FDRK 4415 OB	74
	RR-26-164	RR-26,000	V1712		FDRK 4428 OB	74
	RR-26-164	RR-26,000	Y1897		FDRK 4428 OB	74
RR-26-164	RR-26,000	Z1560		FDRK 4415 OB	74	
180, 185, 186 & 380 Series Single Axles						
RS-23-180	R-23,000	A1899	6.83, 7.17, 7.40 & 7.83 Ratios	FDRK 4438 OB	74	
	R-23,000	A1899	All Other Ratios	FDRK 4437 OB	74	
	R-23,000	C1381	6.83, 7.17, 7.40 & 7.83 Ratios	FDRK 4436 OB	74	
	R-23,000	C1381	All Other Ratios	FDRK 4435 OB	74	
	R-23,000	J1804	6.83, 7.17, 7.40 & 7.83 Ratios	FDRK 4438 OB	74	
	R-23,000	J1804	All Other Ratios	FDRK 4437 OB	74	
	R-23,000	K1753	6.83, 7.17, 7.40 & 7.83 Ratios	FDRK 4436 OB	74	
	R-23,000	K1753	All Other Ratios	FDRK 4435 OB	74	
	R-23,000	U1399	6.83, 7.17, 7.40 & 7.83 Ratios	FDRK 4436 OB	74	
	R-23,000	U1399	All Other Ratios	FDRK 4435 OB	74	
	R-23,000	W1791	6.83, 7.17, 7.40 & 7.83 Ratios	FDRK 4438 OB	74	
	R-23,000	W1791	All Other Ratios	FDRK 4437 OB	74	
RS-23-185	R-23,000	A1899	6.83, 7.17, 7.40 & 7.83 Ratios	FDRK 4438 OB	74	
	R-23,000	A1899	All Other Ratios	FDRK 4437 OB	74	
	R-23,000	C1381	6.83, 7.17, 7.40 & 7.83 Ratios	FDRK 4436 OB	74	
	R-23,000	C1381	All Other Ratios	FDRK 4435 OB	74	
	R-23,000	J1804	6.83, 7.17, 7.40 & 7.83 Ratios	FDRK 4438 OB	74	
	R-23,000	J1804	All Other Ratios	FDRK 4437 OB	74	
	R-23,000	K1753	6.83, 7.17, 7.40 & 7.83 Ratios	FDRK 4436 OB	74	
	R-23,000	K1753	All Other Ratios	FDRK 4435 OB	74	
	R-23,000	U1399	6.83, 7.17, 7.40 & 7.83 Ratios	FDRK 4436 OB	74	
	R-23,000	U1399	All Other Ratios	FDRK 4435 OB	74	
	R-23,000	W1791	6.83, 7.17, 7.40 & 7.83 Ratios	FDRK 4438 OB	74	
	R-23,000	W1791	All Other Ratios	FDRK 4437 OB	74	
RS-23-186	R-23,000	A1899	6.83, 7.17, 7.40 & 7.83 Ratios	FDRK 4438 OB	74	
	R-23,000	A1899	All Other Ratios	FDRK 4437 OB	74	
	R-23,000	C1381	6.83, 7.17, 7.40 & 7.83 Ratios	FDRK 4436 OB	74	
	R-23,000	C1381	All Other Ratios	FDRK 4435 OB	74	
	R-23,000	J1804	6.83, 7.17, 7.40 & 7.83 Ratios	FDRK 4438 OB	74	
	R-23,000	J1804	All Other Ratios	FDRK 4437 OB	74	
	R-23,000	K1753	6.83, 7.17, 7.40 & 7.83 Ratios	FDRK 4436 OB	74	
	R-23,000	K1753	All Other Ratios	FDRK 4435 OB	74	
	R-23,000	U1399	6.83, 7.17, 7.40 & 7.83 Ratios	FDRK 4436 OB	74	
	R-23,000	U1399	All Other Ratios	FDRK 4435 OB	74	
	R-23,000	W1791	6.83, 7.17, 7.40 & 7.83 Ratios	FDRK 4438 OB	74	
	R-23,000	W1791	All Other Ratios	FDRK 4437 OB	74	
RS-23-280	R-23,000	M1625	All Ratios	FDRK 4450 OB	75	
	R-23,000	M1833	6.83, 7.17, 7.40 & 7.83 Ratios	FDRK 4442 OB	75	
	R-23,000	M1833	All Other Ratios	FDRK 4441 OB	75	

Axle Model	Sub Model	Type/Cap.	Carrier	Notes	Fersa Bearing Kit	Pg.
Meritor						
180, 185, 186 & 380 Series Single Axles						
RS-26-180		R-26,000	A1899	6.83, 7.17, 7.40 & 7.83 Ratios	FDRK 4438 OB	74
		R-26,000	A1899	All Other Ratios	FDRK 4437 OB	74
		R-26,000	C1381	All Other Ratios	FDRK 4435 OB	74
		R-26,000	J1804	6.83, 7.17, 7.40 & 7.83 Ratios	FDRK 4438 OB	74
		R-26,000	J1804	All Other Ratios	FDRK 4437 OB	74
		R-26,000	U1399	6.83, 7.17, 7.40 & 7.83 Ratios	FDRK 4436 OB	74
		R-26,000	U1399	All Other Ratios	FDRK 4435 OB	74
		R-26,000	W1791	6.83, 7.17, 7.40 & 7.83 Ratios	FDRK 4438 OB	74
		R-26,000	W1791	All Other Ratios	FDRK 4437 OB	74
RS-26-185		R-26,000	A1899	6.83, 7.17, 7.40 & 7.83 Ratios	FDRK 4438 OB	74
		R-26,000	A1899	All Other Ratios	FDRK 4437 OB	74
		R-26,000	C1381	All Other Ratios	FDRK 4435 OB	74
		R-26,000	J1804	6.83, 7.17, 7.40 & 7.83 Ratios	FDRK 4438 OB	74
		R-26,000	J1804	All Other Ratios	FDRK 4437 OB	74
		R-26,000	U1399	6.83, 7.17, 7.40 & 7.83 Ratios	FDRK 4436 OB	74
		R-26,000	U1399	All Other Ratios	FDRK 4435 OB	74
		R-26,000	W1791	6.83, 7.17, 7.40 & 7.83 Ratios	FDRK 4438 OB	74
		R-26,000	W1791	All Other Ratios	FDRK 4437 OB	74
RS-26-380		R-26,000	M1625	All Ratios	FDRK 4450 OB	75
		R-26,000	M1833	6.83, 7.17, 7.40 & 7.83 Ratios	FDRK 4442 OB	75
		R-26,000	M1833	All Other Ratios	FDRK 4441 OB	75
RS-30-180		R-30,000	A1899	6.83, 7.17, 7.40 & 7.83 Ratios	FDRK 4438 OB	74
		R-30,000	A1899	All Other Ratios	FDRK 4437 OB	74
		R-30,000	C1381	6.83, 7.17, 7.40 & 7.83 Ratios	FDRK 4436 OB	74
		R-30,000	C1381	All Other Ratios	FDRK 4435 OB	74
		R-30,000	J1804	6.83, 7.17, 7.40 & 7.83 Ratios	FDRK 4438 OB	74
		R-30,000	J1804	All Other Ratios	FDRK 4437 OB	74
		R-30,000	K1753	6.83, 7.17, 7.40 & 7.83 Ratios	FDRK 4436 OB	74
		R-30,000	K1753	All Other Ratios	FDRK 4435 OB	74
		R-30,000	U1399	6.83, 7.17, 7.40 & 7.83 Ratios	FDRK 4436 OB	74
		R-30,000	U1399	All Other Ratios	FDRK 4435 OB	74
		R-30,000	W1791	6.83, 7.17, 7.40 & 7.83 Ratios	FDRK 4438 OB	74
		R-30,000	W1791	All Other Ratios	FDRK 4437 OB	74
		RS-30-185		R-30,000	A1899	6.83, 7.17, 7.40 & 7.83 Ratios
R-30,000	A1899			All Other Ratios	FDRK 4437 OB	74
R-30,000	C1381			6.83, 7.17, 7.40 & 7.83 Ratios	FDRK 4436 OB	74
R-30,000	C1381			All Other Ratios	FDRK 4435 OB	74
R-30,000	J1804			6.83, 7.17, 7.40 & 7.83 Ratios	FDRK 4438 OB	74
R-30,000	J1804			All Other Ratios	FDRK 4437 OB	74
R-30,000	K1753			6.83, 7.17, 7.40 & 7.83 Ratios	FDRK 4436 OB	74
R-30,000	K1753			All Other Ratios	FDRK 4435 OB	74
R-30,000	U1399			6.83, 7.17, 7.40 & 7.83 Ratios	FDRK 4436 OB	74
R-30,000	U1399			All Other Ratios	FDRK 4435 OB	74
R-30,000	W1791			6.83, 7.17, 7.40 & 7.83 Ratios	FDRK 4438 OB	74
R-30,000	W1791			All Other Ratios	FDRK 4437 OB	74
RS-30-380				R-30,000	M1625	All Ratios
		R-30,000	M1833	6.83, 7.17, 7.40 & 7.83 Ratios	FDRK 4442 OB	75
		R-30,000	M1833	All Other Ratios	FDRK 4441 OB	75

1.1 \ Heavy Duty Differential Index

Axle Model	Sub Model	Type/Cap.	Carrier	Notes	Fersa Bearing Kit	Pg.
Meritor						
180, 185 & 380 Series Tandem Axles						
RT-48-180	RP-24-180	RF-24,000	M1625	All Ratios	FDRK 4440 OB	75
	RP-24-180	RF-24,000	M1833	6.83, 7.17, 7.40 & 7.83 Ratios	FDRK 4442 OB	75
	RP-24-180	RF-24,000	M1833	All Other Ratios	FDRK 4441 OB	75
	RR-24-180	RR-24,000	A1899	6.83, 7.17, 7.40 & 7.83 Ratios	FDRK 4438 OB	74
	RR-24-180	RR-24,000	A1899	All Other Ratios	FDRK 4437 OB	74
	RR-24-180	RR-24,000	C1381	6.83, 7.17, 7.40 & 7.83 Ratios	FDRK 4436 OB	74
	RR-24-180	RR-24,000	C1381	All Other Ratios	FDRK 4435 OB	74
	RR-24-180	RR-24,000	J1804	6.83, 7.17, 7.40 & 7.83 Ratios	FDRK 4438 OB	74
	RR-24-180	RR-24,000	J1804	All Other Ratios	FDRK 4437 OB	74
	RR-24-180	RR-24,000	U1399	6.83, 7.17, 7.40 & 7.83 Ratios	FDRK 4436 OB	74
	RR-24-180	RR-24,000	U1399	All Other Ratios	FDRK 4435 OB	74
	RR-24-180	RR-24,000	W1791	6.83, 7.17, 7.40 & 7.83 Ratios	FDRK 4438 OB	74
	RR-24-180	RR-24,000	W1791	All Other Ratios	FDRK 4437 OB	74
	RT-48-185	RP-24-185	RF-24,000	M1625	All Ratios	FDRK 4440 OB
RP-24-185		RF-24,000	M1833	6.83, 7.17, 7.40 & 7.83 Ratios	FDRK 4442 OB	75
RP-24-185		RF-24,000	M1833	All Other Ratios	FDRK 4441 OB	75
RR-24-185		RR-24,000	A1899	6.83, 7.17, 7.40 & 7.83 Ratios	FDRK 4438 OB	74
RR-24-185		RR-24,000	A1899	All Other Ratios	FDRK 4437 OB	74
RR-24-185		RR-24,000	C1381	6.83, 7.17, 7.40 & 7.83 Ratios	FDRK 4436 OB	74
RR-24-185		RR-24,000	C1381	All Other Ratios	FDRK 4435 OB	74
RR-24-185		RR-24,000	J1804	6.83, 7.17, 7.40 & 7.83 Ratios	FDRK 4438 OB	74
RR-24-185		RR-24,000	J1804	All Other Ratios	FDRK 4437 OB	74
RR-24-185		RR-24,000	U1399	6.83, 7.17, 7.40 & 7.83 Ratios	FDRK 4436 OB	74
RR-24-185		RR-24,000	U1399	All Other Ratios	FDRK 4435 OB	74
RR-24-185		RR-24,000	W1791	6.83, 7.17, 7.40 & 7.83 Ratios	FDRK 4438 OB	74
RR-24-185		RR-24,000	W1791	All Other Ratios	FDRK 4437 OB	74
RT-48-380		RP-24-380	RF-24,000	All	All Ratios	FDRK 4440 OB
	RR-24-380	RR-24,000	M1625	All Ratios	FDRK 4450 OB	75
	RR-24-380	RR-24,000	M1833	6.83, 7.17, 7.40 & 7.83 Ratios	FDRK 4442 OB	75
	RR-24-380	RR-24,000	M1833	All Other Ratios	FDRK 4441 OB	75
RT-52-180	RP-26-180	RF-26,000	M1625	All Ratios	FDRK 4440 OB	75
	RP-26-180	RF-26,000	M1833	6.83, 7.17, 7.40 & 7.83 Ratios	FDRK 4442 OB	75
	RP-26-180	RF-26,000	M1833	All Other Ratios	FDRK 4441 OB	75
	RR-26-180	RR-26,000	A1899	6.83, 7.17, 7.40 & 7.83 Ratios	FDRK 4438 OB	74
	RR-26-180	RR-26,000	A1899	All Other Ratios	FDRK 4437 OB	74
	RR-26-180	RR-26,000	C1381	6.83, 7.17, 7.40 & 7.83 Ratios	FDRK 4436 OB	74
	RR-26-180	RR-26,000	C1381	All Other Ratios	FDRK 4435 OB	74
	RR-26-180	RR-26,000	J1804	6.83, 7.17, 7.40 & 7.83 Ratios	FDRK 4438 OB	74
	RR-26-180	RR-26,000	J1804	All Other Ratios	FDRK 4437 OB	74
	RR-26-180	RR-26,000	U1399	6.83, 7.17, 7.40 & 7.83 Ratios	FDRK 4436 OB	74
	RR-26-180	RR-26,000	U1399	All Other Ratios	FDRK 4435 OB	74
	RR-26-180	RR-26,000	W1791	6.83, 7.17, 7.40 & 7.83 Ratios	FDRK 4438 OB	74
	RR-26-180	RR-26,000	W1791	All Other Ratios	FDRK 4437 OB	74
	RT-52-185	RP-26-185	RF-26,000	M1625	All Ratios	FDRK 4440 OB
RP-26-185		RF-26,000	M1833	6.83, 7.17, 7.40 & 7.83 Ratios	FDRK 4442 OB	75
RP-26-185		RF-26,000	M1833	All Other Ratios	FDRK 4441 OB	75
RR-26-185		RR-26,000	A1899	6.83, 7.17, 7.40 & 7.83 Ratios	FDRK 4438 OB	74
RR-26-185		RR-26,000	A1899	All Other Ratios	FDRK 4437 OB	74
RR-26-185		RR-26,000	C1381	6.83, 7.17, 7.40 & 7.83 Ratios	FDRK 4436 OB	74
RR-26-185		RR-26,000	C1381	All Other Ratios	FDRK 4435 OB	74
RR-26-185		RR-26,000	J1804	6.83, 7.17, 7.40 & 7.83 Ratios	FDRK 4438 OB	74
RR-26-185		RR-26,000	J1804	All Other Ratios	FDRK 4437 OB	74
RR-26-185		RR-26,000	U1399	6.83, 7.17, 7.40 & 7.83 Ratios	FDRK 4436 OB	74

Axle Model	Sub Model	Type/Cap.	Carrier	Notes	Fersa Bearing Kit	Pg.
------------	-----------	-----------	---------	-------	-------------------	-----

Meritor

180, 185 & 380 Series Tandem Axles

RT-52-185	RR-26-185	RR-26,000	U1399	All Other Ratios	FDRK 4435 OB	74
	RR-26-185	RR-26,000	W1791	6.83, 7.17, 7.40 & 7.83 Ratios	FDRK 4438 OB	74
	RR-26-185	RR-26,000	W1791	All Other Ratios	FDRK 4437 OB	74
RT-52-380	RP-26-380	RF-26,000	All		FDRK 4440 OB	75
	RR-26-380	RR-26,000	M1625	All Ratios	FDRK 4450 OB	75
	RR-26-380	RR-26,000	M1833	6.83, 7.17, 7.40 & 7.83 Ratios	FDRK 4442 OB	75
	RR-26-380	RR-26,000	M1833	All Other Ratios	FDRK 4441 OB	75
RT-58-180	RP-29-180	RF-29,000	M1625	All Ratios	FDRK 4440 OB	75
	RP-29-180	RF-29,000	M1833	6.83, 7.17, 7.40 & 7.83 Ratios	FDRK 4442 OB	75
	RP-29-180	RF-29,000	M1833	All Other Ratios	FDRK 4441 OB	75
	RR-29-180	RR-29,000	A1899	6.83, 7.17, 7.40 & 7.83 Ratios	FDRK 4438 OB	74
	RR-29-180	RR-29,000	A1899	All Other Ratios	FDRK 4437 OB	74
	RR-29-180	RR-29,000	C1381	6.83, 7.17, 7.40 & 7.83 Ratios	FDRK 4436 OB	74
	RR-29-180	RR-29,000	C1381	All Other Ratios	FDRK 4435 OB	74
	RR-29-180	RR-29,000	J1804	6.83, 7.17, 7.40 & 7.83 Ratios	FDRK 4438 OB	74
	RR-29-180	RR-29,000	J1804	All Other Ratios	FDRK 4437 OB	74
	RR-29-180	RR-29,000	U1399	6.83, 7.17, 7.40 & 7.83 Ratios	FDRK 4436 OB	74
	RR-29-180	RR-29,000	U1399	All Other Ratios	FDRK 4435 OB	74
	RR-29-180	RR-29,000	W1791	6.83, 7.17, 7.40 & 7.83 Ratios	FDRK 4438 OB	74
	RR-29-180	RR-29,000	W1791	All Other Ratios	FDRK 4437 OB	74
	RT-58-185	RP-29-185	RF-29,000	M1625	All Ratios	FDRK 4440 OB
RP-29-185		RF-29,000	M1833	6.83, 7.17, 7.40 & 7.83 Ratios	FDRK 4442 OB	75
RT-70-380	RN-35-380	RF-35,000	M1625	All Ratios	FDRK 4440 OB	75
	RN-35-380	RF-35,000	M1833	6.83, 7.17, 7.40 & 7.83 Ratios	FDRK 4442 OB	75
	RN-35-380	RF-35,000	M1833	All Other Ratios	FDRK 4441 OB	75
	RP-35-380	RF-35,000	M1625	All Ratios	FDRK 4440 OB	75
	RP-35-380	RF-35,000	M1833	6.83, 7.17, 7.40 & 7.83 Ratios	FDRK 4442 OB	75
	RP-35-380	RF-35,000	M1833	All Other Ratios	FDRK 4441 OB	75
	RR-35-380	RR-34,000	M1625	All Ratios	FDRK 4440 OB	75
	RR-35-380	RR-34,000	M1833	6.83, 7.17, 7.40 & 7.83 Ratios	FDRK 4442 OB	75
	RR-35-380	RR-34,000	M1833	All Other Ratios	FDRK 4441 OB	75

210, 220, 224, 230 & 240 Series Single Axles

RS-15-210		R-15,000	All		FDRK 4360 OB	73
RS-15-220		R-15,000	All		FDRK 216 OB	60
RS-17-220		R-17,000	All		FDRK 216 OB	60
RS-17-224		R-17,000	All		FDRK 216 OB	60
RS-19-220		R-19,000	All		FDRK 216 OB	60
RS-19-224		R-19,000	All		FDRK 216 OB	60
RS-21-230		R-21,000	All		FDRK 225 OB	61
RS-23-240		R-23,000	All		FDRK 4375 OB	73

720 Series Single Axles

RC-26-720		R-26,000	All		FDRK 601 OB	69
-----------	--	----------	-----	--	--------------------	----

Out of Production Double Reduction Axles

SFDD4640	FDD	R-26,000	3200C122		FDRK 4260 OB	72
	FDD	R-26,000	3800F604		FDRK 4255 OB	72
	FDR	R-26,000	3200C122		FDRK 4270 OB	72
	FDR	R-26,000	3800F604		FDRK 1910 OB	70
SQDD	QDD	R-26,000	3800E473		FDRK 4180 OB	72
	QDD	R-26,000	3800H554		FDRK 4180 OB	72
	QDR	R-26,000	3800K557		FDRK 11R OB	54

1.1 \ Heavy Duty Differential Index

Axle Model	Sub Model	Type/Cap.	Carrier	Notes	Fersa Bearing Kit	Pg.
Meritor						
Out of Production Double Reduction Axles						
SRDD	RDD	RF-22,000	3200D122		FDRK 4220 OB	72
	RDD	RF-22,000	3800A755		FDRK 11FA OB	54
	RDD	RF-22,000	3800H554		FDRK 11FA OB	54
	RDR	RR-22,000	3200D122		FDRK 4190 OB	72
	RDR	RR-22,000	3800A755		FDRK 11R OB	54
	RDR	RR-22,000	3800E473		FDRK 11R OB	54
	RDR	RR-22,000	3800H554		FDRK 11R OB	54
STDD	TDD	RF-25,000	3200D122		FDRK 4220 OB	72
	TDD	RF-25,000	3800D758		FDRK 187F OB	56
	TDR	RR-25,000	3200D122		FDRK 4190 OB	72
	TDR	RR-25,000	3800D758		FDRK 187R OB	56
SUDD	UDD	RF-29,000	3200E122		FDRK 204F OB	59
	UDD	RF-29,000	3800G579		FDRK 4245 OB	72
	UDR	RR-29,000	3800G579		FDRK 4240 OB	72

Out of Production Single Reduction Single Axles						
59722		RR-29,000			FDRK 2108 OB	71
59723		RR-29,000			FDRK 2108 OB	71
59733		RR-29,000			FDRK 2108 OB	71
C100		RR-29,000			FDRK 2111 OB	71
C102		RR-29,000			FDRK 2111 OB	71
C103		RR-29,000			FDRK 2111 OB	71
D140		R-13,000	A1093	Prior to 1985	FDRK 4290 OB	72
		R-13,000	A1093	Prior to 1985	FDRK 4295 OB	73
		R-13,000	A1093	After 1985	FDRK 4300 OB	73
		R-13,000	R1110	After 1985	FDRK 4300 OB	73
F105		R-15,000			FDRK 4315 OB	73
F106		R-15,000			FDRK 4315 OB	73
F140		R-15,000			FDRK 4310 OB	73
F145		R-15,000			FDRK 4310 OB	73
F146		R-15,000			FDRK 4310 OB	73
F147		R-15,000			FDRK 4310 OB	73
F149		R-15,000			FDRK 4310 OB	73
H120		R-17,000		3.55 - 4.63 Ratios	FDRK 9RC OB	54
H140		R-17,000			FDRK 1918 OB	70
H170		R-17,000			FDRK 4325 OB	73
H172		R-17,000			FDRK 4330 OB	73
H173		R-17,000			FDRK 4330 OB	73
L100		R-18,500		3.55 - 4.63 Ratios	FDRK 9RC OB	54
L100A		R-18,500		3.55 - 4.63 Ratios	FDRK 9RC OB	54
		R-18,500		Ratios above 4.63	FDRK 9RB OB	54
L101		R-18,500		3.55 - 4.63 Ratios	FDRK 9RC OB	54
L110		R-18,500		3.55 - 4.63 Ratios	FDRK 9RC OB	54
L110A		R-18,500		3.55 - 4.63 Ratios	FDRK 9RC OB	54
L140		R-18,500			FDRK 1926 OB	70
L145		R-18,500			FDRK 1926 OB	70
L172		R-18,500			FDRK 4330 OB	73
L173		R-18,500			FDRK 4330 OB	73
P174		R-20,000			FDRK 4330 OB	73
PL143		R-18,500			FDRK 172R OB	56
QT140		R-22,000			FDRK 600 OB	69
QT143		R-22,000			FDRK 600 OB	69
QT145		R-22,000			FDRK 600 OB	69

Axle Model	Sub Model	Type/Cap.	Carrier	Notes	Fersa Bearing Kit	Pg.
Meritor						
Out of Production Single Reduction Single Axles						
QT148		R-22,000			FDRK 600 OB	69
R100		R-23,000			FDRK 172R OB	56
R100A		R-23,000			FDRK 172R OB	56
R110		R-23,000			FDRK 172R OB	56
R110A		R-23,000			FDRK 172R OB	56
R112		R-23,000			FDRK 172R OB	56
R113		R-23,000			FDRK 172R OB	56
R114		R-23,000			FDRK 172R OB	56
R115		R-23,000			FDRK 172R OB	56
R120		R-23,000			FDRK 172R OB	56
R140		R-23,000			FDRK 172R OB	56
R141		R-23,000			FDRK 172R OB	56
R143		R-23,000			FDRK 172R OB	56
R155		R-23,000			FDRK 172R OB	56
R162		R-23,000	A1431		FDRK 1984 OB	70
		R-23,000	C679		FDRK 1984 OB	70
		R-23,000	Z1430		FDRK 1984 OB	70
		R-23,000	Z806		FDRK 1984 OB	70
R164		R-23,000	A1431		FDRK 1984 OB	70
		R-23,000	C679		FDRK 1984 OB	70
		R-23,000	Z1430		FDRK 1984 OB	70
		R-23,000	Z806		FDRK 1984 OB	70
R170		R-23,000		Prior to 12/1/83 Exc. 7.40 Ratio	FDRK 50 OB	55
R171		R-23,000			FDRK 50A OB	55
R173		R-23,000			FDRK 50A OB	55
R200		R-23,000		Old Style	FDRK 1925 OB	70
		R-23,000		New Style	FDRK 1925A OB	70
RL170		R-20,000		Prior to 12/1/83 Exc. 7.40 Ratio	FDRK 50 OB	55
RT140		R-23,000			FDRK 172R OB	56
S162		R-23,000	A1431		FDRK 1984 OB	70
		R-23,000	C679		FDRK 1984 OB	70
		R-23,000	Z1430		FDRK 1984 OB	70
		R-23,000	Z806		FDRK 1984 OB	70
S170		R-26,000		Prior to 12/1/83 Exc. 7.40 Ratio	FDRK 50 OB	55
U140		R-23,000			FDRK 172R OB	56
U240		R-29,000		Old Style	FDRK 1925 OB	70
		R-29,000		New Style	FDRK 1925A OB	70
U340		R-29,000		Old Style	FDRK 1925 OB	70
		R-29,000		New Style	FDRK 1925A OB	70
W170		R-36-38,000			FDRK 50 OB	55

Out of Production Single Reduction Tandem Axles						
SL100	LD100	RF-17,000			FDRK 194F OB	57
	LR100	RR-17,000			FDRK 194RB OB	57
SL100P	LP100	RF-17,000			FDRK 194F OB	57
	LR100	RR-17,000			FDRK 194RB OB	57
SLHD	LHD	RF-17,000		3.55 - 4.63 Ratios	FDRK 900F OB	70
	LHR	RR-17,000		3.55 - 4.63 Ratios	FDRK 9RC OB	54
SQ100	QD100	RF-20,000			FDRK 194F OB	57
	QR100	RR-20,000			FDRK 194RB OB	57
SQ100P	QP100	RF-20,000			FDRK 194F OB	57
	QR100	RR-20,000			FDRK 194RB OB	57

1.1 \ Heavy Duty Differential Index

Axle Model	Sub Model	Type/Cap.	Carrier	Notes	Fersa Bearing Kit	Pg.
Meritor						
Out of Production Single Reduction Tandem Axles						
SQHD	QHD	RF-20,000		3.55 - 4.63 Ratios	FDRK 900F OB	70
	QHR	RR-20,000		3.55 - 4.63 Ratios	FDRK 9RC OB	54
SQHP	QAR	RR-20,000			FDRK 194RA OB	57
	QHP	RF-20,000			FDRK 194F OB	57
SQR100	QRD100	RF-22,000			FDRK 194F OB	57
	QRR100	RR-22,000			FDRK 194RB OB	57
SQR100P	QRP100	RF-22,000			FDRK 194F OB	57
	QRR100	RR-22,000			FDRK 194RB OB	57
SR170	R170	RR-22,000	G1255	7.40 Ratio Only	FDRK 4125 OB	71
	R170	RR-22,000	G1255	All ratios Exc. 7.40	FDRK 203F OB	58
	R170	RR-22,000	M1625	7.40 Ratio Only	FDRK 4145 OB	71
	R170	RR-22,000	M1625	All ratios Exc. 7.40	FDRK 4140 OB	71
	R170	RR-22,000	X1324	All ratios Exc. 7.40	FDRK 4135 OB	71
	R170R	RR-24,000		7.40 Ratio Only	FDRK 4130 OB	71
SR270	R270	RF-24,000	G1255	7.40 Ratio Only	FDRK 4125 OB	71
	R270	RF-24,000	G1255	All ratios Exc. 7.40	FDRK 203F OB	58
	R270	RF-24,000	J1076	7.40 Ratio Only	FDRK 4125 OB	71
	R270	RF-24,000	J1076	All ratios Exc. 7.40	FDRK 203F OB	58
	R270	RF-24,000	M1625	7.40 Ratio Only	FDRK 4145 OB	71
	R270	RF-24,000	M1625	All ratios Exc. 7.40	FDRK 4140 OB	71
	R270	RF-24,000	X1324	All ratios Exc. 7.40	FDRK 4135 OB	71
	R270R	RR-24,000	M1625	7.40 Ratio Only	FDRK 4155A OB	72
	R270R	RR-24,000	M1625	All ratios Exc. 7.40	FDRK 4155 OB	71
	SR280	R280	RF-24,000	G1255	7.40 Ratio Only	FDRK 4125 OB
R280		RF-24,000	G1255	All ratios Exc. 7.40	FDRK 203F OB	58
R280		RF-24,000	J1076	7.40 Ratio Only	FDRK 4125 OB	71
R280		RF-24,000	J1076	All ratios Exc. 7.40	FDRK 203F OB	58
R280		RF-24,000	M1625	7.40 Ratio Only	FDRK 4145 OB	71
R280		RF-24,000	M1625	All ratios Exc. 7.40	FDRK 4140 OB	71
R280		RF-24,000	X1324	All ratios Exc. 7.40	FDRK 4135 OB	71
R280R		RR-24,000	M1625	7.40 Ratio Only	FDRK 4155A OB	72
R280R		RR-24,000	M1625	All ratios Exc. 7.40	FDRK 4155 OB	71
SSH		SHD	RF-23,000		Ball Bearing Input & Output Shaft	FDRK 172F OB
	SHR	RR-23,000		Early Style Seal	FDRK 172R OB	56
SSHP	SHP	RF-23,000		Ball Bearing Input & Output Shaft	FDRK 172F OB	56
	SHP	RF-23,000		Taper Bearing Input Output Shaft w/ Upgraded O/S Seal	FDRK 4095 OB	71
	SHR	RR-23,000		Early Style Seal	FDRK 172R OB	56
STHD	THD	RF-25,000		Ball Bearing Input & Output Shaft	FDRK 172F OB	56
	THR	RR-25,000		Early Style Seal	FDRK 172R OB	56
SU170	U170	RF-29,000	G1255	7.40 Ratio Only	FDRK 4125 OB	71
	U170	RF-29,000	G1255	All ratios Exc. 7.40	FDRK 203F OB	58
	U170	RF-29,000	M1625	7.40 Ratio Only	FDRK 4145 OB	71
	U170	RF-29,000	M1625	All ratios Exc. 7.40	FDRK 4140 OB	71
	U170	RF-29,000	X1324	All ratios Exc. 7.40	FDRK 4135 OB	71
	U170R	RR-29,000		7.40 Ratio Only	FDRK 4130 OB	71
SU270	U270	RF-29,000	G1255	7.40 Ratio Only	FDRK 4125 OB	71
	U270	RF-29,000	G1255	All ratios Exc. 7.40	FDRK 203F OB	58
	U270	RF-29,000	J1076	7.40 Ratio Only	FDRK 4125 OB	71
	U270	RF-29,000	J1076	All ratios Exc. 7.40	FDRK 203F OB	58
	U270	RF-29,000	M1625	7.40 Ratio Only	FDRK 4145 OB	71
	U270	RF-29,000	M1625	All ratios Exc. 7.40	FDRK 4140 OB	71
	U270	RF-29,000	X1324	All ratios Exc. 7.40	FDRK 4135 OB	71
	U270	RF-29,000		7.40 Ratio Only	FDRK 4130 OB	71

Axle Model	Sub Model	Type/Cap.	Carrier	Notes	Fersa Bearing Kit	Pg.
------------	-----------	-----------	---------	-------	-------------------	-----

Meritor

Out of Production Single Reduction Tandem Axles

SU270	U270R	RR-29,000	M1625	7.40 Ratio Only	FDRK 4155A OB	72
	U270R	RR-29,000	M1625	All ratios Exc. 7.40	FDRK 4155 OB	71
SU280	U280	RF-29,000	G1255	7.40 Ratio Only	FDRK 4125 OB	71
	U280	RF-29,000	G1255	All ratios Exc. 7.40	FDRK 203F OB	58
	U280	RF-29,000	J1076	7.40 Ratio Only	FDRK 4125 OB	71
	U280	RF-29,000	J1076	All ratios Exc. 7.40	FDRK 203F OB	58
	U280	RF-29,000	M1625	7.40 Ratio Only	FDRK 4145 OB	71
	U280	RF-29,000	M1625	All ratios Exc. 7.40	FDRK 4140 OB	71
	U280	RF-29,000	X1324	All ratios Exc. 7.40	FDRK 4135 OB	71
	U280R	RR-29,000	M1625	7.40 Ratio Only	FDRK 4155A OB	72
	U280R	RR-29,000	M1625	All ratios Exc. 7.40	FDRK 4155 OB	71
SUHD	UHD	RF-29,000		Ball Bearing Input & Output Shaft	FDRK 172F OB	56
	UHR	RR-29,000		Early Style Seal	FDRK 172R OB	56
SW170	W170	RF-35,000	G1255	7.40 Ratio Only	FDRK 4125 OB	71
	W170	RF-35,000	G1255	All ratios Exc. 7.40	FDRK 203F OB	58
	W170	RF-35,000	J1076	7.40 Ratio Only	FDRK 4125 OB	71
	W170	RF-35,000	J1076	All ratios Exc. 7.40	FDRK 203F OB	58
	W170	RF-35,000	M1625	7.40 Ratio Only	FDRK 4145 OB	71
	W170	RF-35,000	M1625	All ratios Exc. 7.40	FDRK 4140 OB	71
	W170	RF-35,000	X1324	All ratios Exc. 7.40	FDRK 4135 OB	71
	W170R	RR-34,000		7.40 Ratio Only	FDRK 4130 OB	71
SW270	W270	RF-35,000	G1255	7.40 Ratio Only	FDRK 4125 OB	71
	W270	RF-35,000	G1255	All ratios Exc. 7.40	FDRK 203F OB	58
	W270	RF-35,000	J1076	7.40 Ratio Only	FDRK 4125 OB	71
	W270	RF-35,000	J1076	All ratios Exc. 7.40	FDRK 203F OB	58
	W270	RF-35,000	M1625	7.40 Ratio Only	FDRK 4145 OB	71
	W270	RF-35,000	M1625	All ratios Exc. 7.40	FDRK 4140 OB	71
	W270	RF-35,000	X1324	All ratios Exc. 7.40	FDRK 4135 OB	71
	W270R	RR-34,000	M1625	7.40 Ratio Only	FDRK 4155A OB	72
	W270R	RR-34,000	M1625	All ratios Exc. 7.40	FDRK 4155 OB	71
SW280	W280	RF-35,000	G1255	7.40 Ratio Only	FDRK 4125 OB	71
	W280	RF-35,000	G1255	All ratios Exc. 7.40	FDRK 203F OB	58
	W280	RF-35,000	J1076	7.40 Ratio Only	FDRK 4125 OB	71
	W280	RF-35,000	J1076	All ratios Exc. 7.40	FDRK 203F OB	58
	W280	RF-35,000	M1625	7.40 Ratio Only	FDRK 4145 OB	71
	W280	RF-35,000	M1625	All ratios Exc. 7.40	FDRK 4140 OB	71
	W280	RF-35,000	X1324	All ratios Exc. 7.40	FDRK 4135 OB	71
	W280R	RR-34,000	M1625	7.40 Ratio Only	FDRK 4155A OB	72
	W280R	RR-34,000	M1625	All ratios Exc. 7.40	FDRK 4155 OB	71

Volvo

EV-80		Front			FDRK 801 OB	70
		Rear			FDRK 802 OB	70
EV-87		Front			FDRK 801 OB	70
		Rear			FDRK 802 OB	70

White

124C		R-21,000			FDRK 111 OB	55
134C		R-23,000			FDRK 111 OB	55

1.2 \ F-Box Differential Rebuild Kit

POSITION	FERSA	QTY
FDRK 1 OB		
Differential Left	56425/56650	1
Differential Right	497/493	1
Electric Shift	6200 ZNR	1
Bevel Pinion Rear	55200 C/55437	1
Bevel Pinion Pilot	F 19083	1
Bevel Pinion Front	55200 C/55437	1

FDRK 1A OB		
Differential Left	567/563	1
Differential Right	497/493	1
Bevel Pinion Rear	55200 C/55437	1
Bevel Pinion Pilot	F 19083	1
Bevel Pinion Front	55200 C/55437	1

FDRK 9F OB		
Differential Left	496/493	1
Differential Right	496/493	1
Drive Gear Front	29675/29630	1
Drive Gear Rear	29675/29630	1
Idler Gear	31597/31520	2
Input Shaft	*	1
Bevel Pinion Rear	72200 C/72487	1
Bevel Pinion Pilot	*	1
Bevel Pinion Front	72200 C/72487	1
Thrushaft	6209	1

FDRK 9R OB		
Differential Left	496/493	1
Differential Right	496/493	1
Bevel Pinion Rear	72200 C/72487	1
Bevel Pinion Pilot	*	1
Bevel Pinion Front	72188 C/72487	1

FDRK 9RB OB		
Differential Left	496/493	1
Differential Right	496/493	1
Bevel Pinion Rear	72200 C/72487	1
Bevel Pinion Pilot	F 19035	1
Bevel Pinion Front	72188 C/72487	1

FDRK 9RC OB		
Differential Left	497/493	1
Differential Right	496/493	1
Bevel Pinion Rear	72200 C/72487	1
Bevel Pinion Pilot	F 19035	1
Bevel Pinion Front	72188 C/72487	1

POSITION	FERSA	QTY
FDRK 11FA OB		
Cross Shaft Left	*	1
Cross Shaft Left	*	1
Cross Shaft Right	66225/66462	2
Differential Left	581/572	1
Differential Right	581/572	1
Bevel Pinion Rear	42350/42584	1
Bevel Pinion Pilot	*	1
Bevel Pinion Front	497/493	1
Thrushaft	6212	1

FDRK 11R OB		
Cross Shaft Left	*	1
Cross Shaft Right	66225/66462	2
Differential Left	581/572	1
Differential Right	581/572	1
Bevel Pinion Rear	42350/42584	1
Bevel Pinion Pilot	*	1
Bevel Pinion Front	497/493	1

FDRK 18D OB		
Differential Left	665/653	1
Differential Right	42381/42584	1
Bevel Pinion Rear	78215 C/78551	1
Bevel Pinion Pilot	*	1
Bevel Pinion Front	72212 C/72487	1

FDRK 18E OB		
Differential Left	665/653	1
Differential Right	42381/42584	1
Bevel Pinion Rear	78215 C/78551	1
Bevel Pinion Pilot	F 19084	1
Bevel Pinion Front	72212 C/72487	1

FDRK 23 OB		
Differential Left	42381/42584	1
Differential Right	495 A/493	1
Electric Shift	6200 ZNR	1
Bevel Pinion Rear	HM 903249/HM 903210	1
Bevel Pinion Pilot	F 19083	1
Bevel Pinion Front	HM 903249/HM 903210	1

FDRK 23B OB		
Differential Left	567/563	1
Differential Right	3994/3920	1
Bevel Pinion Rear	HM 903249/HM 903210	1
Bevel Pinion Pilot	F 19083	1
Bevel Pinion Front	HM 903249/HM 903210	1

POSITION	FERSA	QTY
FDRK 23D OB		
Differential Left	42381/42584	1
Differential Right	495 A/493	1
Electric Shift	6200 ZNR	1
Bevel Pinion Rear	55175 C/55437	1
Bevel Pinion Pilot	F 19083	1
Bevel Pinion Front	55175 C/55437	1

FDRK 24 OB		
Differential Left	498/493	1
Differential Right	33275/33472	1
Electric Shift	6200 ZNR	1
Bevel Pinion Rear	HM 903249/HM 903210	1
Bevel Pinion Pilot	F 19040	1
Bevel Pinion Front	HM 903249/HM 903210	1

FDRK 50 OB		
Differential Left	52387/52618	1
Differential Right	598/592 A	1
Bevel Pinion Rear	H 715343/H 715311	1
Bevel Pinion Pilot	*	1
Bevel Pinion Front	H 715334/H 715311	1

FDRK 50A OB		
Differential Left	52387/52618	1
Differential Right	598/592 A	1
Bevel Pinion Rear	H 715343/H 715311	1
Bevel Pinion Pilot	*	1
Bevel Pinion Front	HM 813843/HM 813810	1

FDRK 64F OB		
Differential Left	497/493	1
Differential Right	56425/56650	1
Input Shaft Front	6311	1
Output Shaft Front	34274/34492 A	1
Output Shaft Rear	*	1
Bevel Pinion Rear	72200 C/72487	1
Bevel Pinion Pilot	F 19083	1
Bevel Pinion Front	72200 C/72487	1

FDRK 64FC OB		
Differential Left	497/493	1
Differential Right	567/563	1
Input Shaft Front	6311	1
Output Shaft Front	34274/34492 A	1
Output Shaft Rear	*	1
Bevel Pinion Rear	72200 C/72487	1
Bevel Pinion Pilot	F 19083	1
Bevel Pinion Front	72200 C/72487	1

POSITION	FERSA	QTY
FDRK 64FD OB		
Differential Left	497/493	1
Differential Right	567/563	1
Input Shaft Front	JM 207049/JM 207010	1
Output Shaft Front	34274/34492 A	1
Output Shaft Rear	*	1
Bevel Pinion Rear	72200 C/72487	1
Bevel Pinion Pilot	F 19083	1
Bevel Pinion Front	72200 C/72487	1

FDRK 64FE OB		
Differential Left	497/493	1
Differential Right	56425/56650	1
Input Shaft Front	JM 207049/JM 207010	1
Output Shaft Front	34274/34492 A	1
Output Shaft Rear	*	1
Bevel Pinion Rear	72200 C/72487	1
Bevel Pinion Pilot	F 19083	1
Bevel Pinion Front	72200 C/72487	1

FDRK 72 OB		
Differential Left	68450/68712	1
Differential Right	42346/42584	1
Electric Shift	6200 ZNR	1
Bevel Pinion Rear	72212 C/72487	1
Bevel Pinion Pilot	F 19084	1
Bevel Pinion Front	72212 C/72487	1

FDRK 72A OB		
Differential Left	68450/68712	1
Differential Right	42346/42584	1
Bevel Pinion Rear	78215 C/78551	1
Bevel Pinion Pilot	F 19084	1
Bevel Pinion Front	72212 C/72487	1

FDRK 72B OB		
Differential Left	68462/68712	1
Differential Right	42346/42584	1
Bevel Pinion Rear	78215 C/78551	1
Bevel Pinion Pilot	F 19084	1
Bevel Pinion Front	72212 C/72487	1

FDRK 111 OB		
Differential Left	685/672	1
Differential Right	685/672	1
Bevel Pinion Rear	H 913842/H 913810	1
Bevel Pinion Pilot	*	1
Bevel Pinion Front	HM 911245/HM 911210	1

1.2 \ F-Box Differential Rebuild Kit

POSITION	FERSA	QTY
FDRK 117 OB		
Cross Shaft Left	6379/6320	1
Cross Shaft Right	6379/6320	1
Differential Left	598 A/592 A	1
Differential Right	598 A/592 A	1
Bevel Pinion Rear	H 715340/H 715310	1
Bevel Pinion Front	65212/65500	1

FDRK 117A OB		
Cross Shaft Left	6379/6320	1
Cross Shaft Right	6379/6320	1
Differential Left	598 A/592 A	1
Differential Right	598 A/592 A	1
Bevel Pinion Rear	H 715340/H 715310	1
Bevel Pinion Front	65212/65500	1

FDRK 170 OB		
Differential Left	42381/42584	1
Differential Right	33287/33472	1
Electric Shift	6200 ZNR	1
Bevel Pinion Rear	55200 C/55437	1
Bevel Pinion Pilot	*	1
Bevel Pinion Front	HM 804848/HM 804810	1

FDRK 172F OB		
Differential Left	47890/47820	1
Differential Right	47890/47820	1
Drive Gear Front	*	1
Input Shaft	6313	1
Bevel Pinion Rear	H 715343/H 715311	1
Bevel Pinion Front	65237/65500	1
Thrushaft	6210	1

FDRK 172FA OB		
Differential Left	47890/47820	1
Differential Right	47890/47820	1
Drive Gear Front	*	1
Input Shaft	*	1
Bevel Pinion Rear	H 715343/H 715311	1
Bevel Pinion Front	65237/65500	1
Thrushaft	6210	1

FDRK 172FB OB		
Differential Left	47890/47820	1
Differential Right	47890/47820	1
Input Shaft	JH 211749/JH 211710	1
Inter Differential	JLM 714149/JLM 714110	1
Bevel Pinion Rear	H 715343/H 715311	1
Bevel Pinion Front	65237/65500	1
Thrushaft	LM 104949/JLM 104910	2

POSITION	FERSA	QTY
FDRK 172R OB		
Differential Left	47890/47820	1
Differential Right	47890/47820	1
Bevel Pinion Rear	H 715343/H 715311	1
Bevel Pinion Pilot	F 19034	1
Bevel Pinion Front	H 715334/H 715311	1

FDRK 187F OB		
Cross Shaft Left	*	1
Cross Shaft Right	66225/66462	2
Differential Left	HM 516449 C/HM 516410	1
Differential Right	HM 516449 C/HM 516410	1
Input Shaft	387 A/382 A	2
Bevel Pinion Rear	42350/42584	1
Bevel Pinion Pilot	*	1
Bevel Pinion Front	497/493	1
Thrushaft	6212	1

FDRK 187R OB		
Cross Shaft Left	*	1
Cross Shaft Right	66225/66462	2
Differential Left	HM 516449 C/HM 516410	1
Differential Right	HM 516449 C/HM 516410	1
Bevel Pinion Rear	42350/42584	1
Bevel Pinion Pilot	*	1
Bevel Pinion Front	497/493	1

FDRK 191F OB		
Differential Left	3984/3925	1
Differential Right	3984/3925	1
Drive Gear	6213 ZNR	1
Idler Gear	25877/25821	2
Input Shaft	6022 NR	1
Input Shaft	*	1
Output Shaft	6210	1
Bevel Pinion Rear	55175 C/55437	1
Bevel Pinion Pilot	*	1
Bevel Pinion Front	55175 C/55437	1
Thrust Race	*	2
Thrust Race	*	1

FDRK 191R OB		
Differential Left	3984/3925	1
Differential Right	3984/3925	1
Bevel Pinion Rear	55175 C/55437	1
Bevel Pinion Pilot	*	1
Bevel Pinion Front	55175 C/55437	1

POSITION	FERSA	QTY
FDRK 192FB OB		
Differential Left	47890/47820	1
Differential Right	47890/47820	1
Driveshaft	L 610549/L 610510	2
Idler Gear	25877/25821	2
Input Shaft	6022 NR	1
Input Shaft	*	1
Output Shaft	6210	1
Bevel Pinion Rear	72225 C/72487	1
Bevel Pinion Pilot	F 19100	1
Bevel Pinion Front	72225 C/72487	1
Thrust Race	*	2
Thrust Race	*	1

FDRK 192FC OB		
Differential Left	47890/47820	1
Differential Right	47890/47820	1
Driveshaft	L 610549/L 610510	2
Idler Gear	25877/25821	2
Input Shaft	6022 NR/C3	1
Input Shaft	*	1
Output Shaft	6210	1
Bevel Pinion Rear	78225 C/78551	1
Bevel Pinion Pilot	F 19100	1
Bevel Pinion Front	78225 C/78551	1

FDRK 192R OB		
Differential Left	47890/47820	1
Differential Right	47890/47820	1
Bevel Pinion Rear	72225 C/72487	1
Bevel Pinion Pilot	F 19100	1
Bevel Pinion Front	72225 C/72487	1

FDRK 192RA OB		
Differential Left	47890/47820	1
Differential Right	47890/47820	1
Bevel Pinion Rear	78225 C/78551	1
Bevel Pinion Pilot	F 19100	1
Bevel Pinion Front	78225 C/78551	1

FDRK 192RB OB		
Differential Left	47890/47820	1
Differential Right	47890/47820	1
Bevel Pinion Rear	72225 C/72487	1
Bevel Pinion Pilot	F 19100	1
Bevel Pinion Front	72225 C/72487	1

POSITION	FERSA	QTY
FDRK 193 OB		
Differential Left	497/493	1
Differential Right	56425/56650	1
Input Shaft	JH 307749/JH 307710	1
Output Shaft Front	34274/34492 A	1
Output Shaft Rear	*	1
Bevel Pinion Rear	72218 C/72487	1
Bevel Pinion Pilot	F 19083	1
Bevel Pinion Front	72200 C/72487	1

FDRK 193A OB		
Differential Left	497/493	1
Differential Right	567/563	1
Input Shaft Front	JH 307749/JH 307710	1
Output Shaft Front	34274/34492 A	1
Output Shaft Rear	*	1
Bevel Pinion Rear	72218 C/72487	1
Bevel Pinion Pilot	F 19083	1
Bevel Pinion Front	72200 C/72487	1

FDRK 194F OB		
Differential Left	JM 716649/JM 716610	1
Differential Right	JM 716649/JM 716610	1
Drive Gear Front	JLM 710949 C/JLM 710910	1
Input Shaft	JM 511946/JM 511910	1
Bevel Pinion Rear	72212 C/72487	1
Bevel Pinion Pilot	F 19035	1
Bevel Pinion Front	72212 C/72487	1
Thrushaft	LM 603049/LM 603011	2

FDRK 194R OB		
Differential Left	JM 716649/JM 716610	1
Differential Right	JM 716649/JM 716610	1
Bevel Pinion Rear	65237/65500	1
Bevel Pinion Front	72201 C/72487	1

FDRK 194RA OB		
Differential Left	JM 716649/JM 716610	1
Differential Right	JM 716649/JM 716610	1
Bevel Pinion Rear	65237/65500	1
Bevel Pinion Front	72225 C/72487	1

FDRK 194RB OB		
Differential Left	JM 716649/JM 716610	1
Differential Right	JM 716649/JM 716610	1
Bevel Pinion Rear	72212 C/72487	1
Bevel Pinion Pilot	F 19035	1
Bevel Pinion Front	72212 C/72487	1

1.2 \ F-Box Differential Rebuild Kit

POSITION	FERSA	QTY
FDRK 195 OB		
Differential Left	28584/28521	1
Differential Right	28584/28521	1
Bevel Pinion Rear	27881/27820	1
Bevel Pinion Pilot	*	1
Bevel Pinion Front	27880/27820	1

POSITION	FERSA	QTY
FDRK 196 OB		
Differential Left	497/493	1
Differential Right	567/563	1
Input Shaft	3979/JM 511910	1
Output Shaft Front	29675/29620	1
Output Shaft Rear	*	1
Bevel Pinion Rear	72218 C/72487	1
Bevel Pinion Pilot	F 19083	1
Bevel Pinion Front	HM 807049/HM 807010	1

POSITION	FERSA	QTY
FDRK 198 OB		
Differential Left	56425/56650	1
Differential Right	56425/56650	1
Bevel Pinion Rear	H 715343/H 715311	1
Bevel Pinion Pilot	F 19034	1
Bevel Pinion Front	H 715343/H 715311	1

POSITION	FERSA	QTY
FDRK 200F OB		
Differential Left	47890/47820	1
Differential Right	47890/47820	1
Idler Gear	3877/3820	2
Output Shaft	6210	1
Bevel Pinion Rear	72225 C/72487	1
Bevel Pinion Pilot	F 19100	1
Bevel Pinion Front	72225 C/72487	1
Power Divider	JLM 710949 C/JLM 710910	2
Power Divider Case Intermediate	28985/28921	1
Power Divider Front Side Gear Thrust	*	2
Power Divider Intermedial Disc Rear	*	1

POSITION	FERSA	QTY
FDRK 200FA OB		
Differential Left	47890/47820	1
Differential Right	47890/47820	1
Idler Gear	M 802048/M 802011	2
Output Shaft	6210	1
Bevel Pinion Rear	72225 C/72487	1
Bevel Pinion Pilot	F 19100	1
Bevel Pinion Front	72225 C/72487	1
Power Divider	JLM 710949 C/JLM 710910	2
Power Divider Case Intermediate	28985/28921	1
Power Divider Front Side Gear Thrust	*	2
Power Divider Intermedial Disc Rear	*	1

POSITION	FERSA	QTY
FDRK 201F OB		
Differential Left	56425/56650	1
Differential Right	56425/56650	1
Idler Gear	3877/3820	2
Output Shaft	6210	1
Bevel Pinion Rear	H 715343/H 715311	1
Bevel Pinion Pilot	F 19034	1
Bevel Pinion Front	HM 813844/HM 813810	1
Power Divider	JLM 710949 C/JLM 710910	2
Power Divider Case Intermediate	28985/28921	1
Power Divider Front Side Gear Thrust	*	2
Power Divider Intermedial Disc Rear	*	1

POSITION	FERSA	QTY
FDRK 201FA OB		
Differential Left	56425/56650	1
Differential Right	56425/56650	1
Idler Gear	M 802048/M 802011	2
Output Shaft	6210	1
Bevel Pinion Rear	H 715343/H 715311	1
Bevel Pinion Pilot	F 19034	1
Bevel Pinion Front	HM 813844/HM 813810	1
Power Divider	JLM 710949 C/JLM 710910	2
Power Divider Case Intermediate	28985/28921	1
Power Divider Front Side Gear Thrust	*	2
Power Divider Intermedial Disc Rear	*	1

POSITION	FERSA	QTY
FDRK 201R OB		
Differential Left	56425/56650	1
Differential Right	56425/56650	1
Bevel Pinion Rear	H 715343/H 715311	1
Bevel Pinion Pilot	F 19034	1
Bevel Pinion Front	HM 813844/HM 813810	1

POSITION	FERSA	QTY
FDRK 202 OB		
Differential Left	3984/3925	1
Differential Right	3984/3925	1
Bevel Pinion Rear	HM 903249 A/HM 903210	1
Bevel Pinion Pilot	*	1
Bevel Pinion Front	HM 903249 A/HM 903210	1

POSITION	FERSA	QTY
FDRK 203F OB		
Differential Left	52387/52618	1
Differential Right	598/592 A	1
Input Shaft Front	HM 813841/HM 813810	1
Input Shaft Rear	JM 515649/JM 515610	1
Oil Pump Idler Gear	*	1
Bevel Pinion Rear	78250 AC/78551	1
Bevel Pinion Pilot	*	1
Bevel Pinion Front	78250 AC/78551	1
Thrushaft	385 A/382 A	2

POSITION	FERSA	QTY
FDRK 204F OB		
Cross Shaft Left	*	1
Cross Shaft Right	641/632	2
Differential Left	HM 516449 C/HM 516410	1
Differential Right	HM 516449 C/HM 516410	1
Input Shaft	394 A/392	2
Bevel Pinion Rear	42350/42584	1
Bevel Pinion Pilot	*	1
Bevel Pinion Front	42350/42584	1
Thrushaft	385 A/382 A	2

FDRK 204R OB		
Cross Shaft Left	65237/65500	1
Cross Shaft Right	65237/65500	1
Differential Left	HM 516449 C/HM 516410	1
Differential Right	HM 516449 C/HM 516410	1
Bevel Pinion Rear	H 715345/H 715311	1
Bevel Pinion Front	HM 807046/HM 807010	1

FDRK 205 OB		
Cross Shaft Left	*	1
Cross Shaft Right	621/612	1
Differential Left	*	1
Differential Right	47687/47623 A	1
Bevel Pinion Rear	5760/5735	1
Bevel Pinion Front	5575/552 A	1

FDRK 206 OB		
Cross Shaft Left	*	1
Cross Shaft Right	621/612	1
Differential Left	*	1
Differential Right	47687/47623 A	1
Drive Gear Front	6211	1
Input Shaft	6213 NR	1
Bevel Pinion Rear	497/492 A	1
Bevel Pinion Front	576/572	1

FDRK 207 OB		
Differential Left	497/493	1
Differential Right	56425/56650	1
Input Shaft	3979/JM 511910	1
Output Shaft Front	29675/29620	1
Output Shaft Rear	*	1
Bevel Pinion Rear	72218 C/72487	1
Bevel Pinion Pilot	F 19083	1
Bevel Pinion Front	HM 807049/HM 807010	1

POSITION	FERSA	QTY
FDRK 208 OB		
Differential Left	42381/42584	1
Differential Right	665/653	1
Input Shaft	JM 511946/JM 511910	1
Output Shaft Front	33275/33472	1
Output Shaft Rear	*	1
Pinion Forward	*	1
Bevel Pinion Rear	72212 C/72487	1
Bevel Pinion Pilot	F 19084	1
Bevel Pinion Front	72212 C/72487	1

FDRK 208A OB		
Differential Left	42381/42584	1
Differential Right	665/653	1
Input Shaft	6313	1
Output Shaft Front	33275/33472	1
Output Shaft Rear	*	1
Pinion Forward	*	1
Bevel Pinion Rear	72212 C/72487	1
Bevel Pinion Pilot	F 19084	1
Bevel Pinion Front	72212 C/72487	1

FDRK 209 OB		
Differential Left	42346/42584	1
Differential Right	68462/68712	1
Input Shaft	6313	1
Output Shaft Front	33275/33472	1
Output Shaft Rear	*	1
Pinion Forward	*	1
Bevel Pinion Rear	72212 C/72487	1
Bevel Pinion Pilot	F 19084	1
Bevel Pinion Front	72212 C/72487	1

FDRK 209A OB		
Differential Left	42346/42584	1
Differential Right	68450/68712	1
Input Shaft	6313	1
Output Shaft Front	33275/33472	1
Output Shaft Rear	*	1
Pinion Forward	*	1
Bevel Pinion Rear	72212 C/72487	1
Bevel Pinion Pilot	F 19084	1
Bevel Pinion Front	72212 C/72487	1

FDRK 210 OB		
Differential Left	42346/42584	1
Differential Right	68462/68712	1
Input Shaft	JM 511946/JM 511910	1
Output Shaft Front	33275/33472	1
Output Shaft Rear	*	1
Pinion Forward	*	1
Bevel Pinion Rear	72212 C/72487	1
Bevel Pinion Pilot	F 19084	1
Bevel Pinion Front	72212 C/72487	1

1.2 \ F-Box Differential Rebuild Kit

POSITION	FERSA	QTY
FDRK 211F OB		
Differential Left	42381/42584	1
Differential Right	68462/68712	1
Input Shaft	JM 511946/JM 511910	1
Output Shaft Front	33275/33472	1
Output Shaft Rear	*	1
Pinion Forward	*	1
Bevel Pinion Rear	72212 C/72487	1
Bevel Pinion Pilot	F 19084	1
Bevel Pinion Front	72212 C/72487	1

FDRK 211FA OB		
Differential Left	42381/42584	1
Differential Right	68450/68712	1
Input Shaft	JM 511946/JM 511910	1
Output Shaft Front	33275/33472	1
Output Shaft Rear	*	1
Pinion Forward	*	1
Bevel Pinion Rear	72212 C/72487	1
Bevel Pinion Pilot	F 19084	1
Bevel Pinion Front	72212 C/72487	1

FDRK 212F OB		
Cross Shaft Left	*	1
Cross Shaft Left	H 414235/H 414210	1
Differential Left	*	1
Differential Right	766/753 A	1
Output Shaft	6212	1
Bevel Pinion Rear	740/742	1
Bevel Pinion Front	661/653	1
Power Divider	*	2

FDRK 212R OB		
Cross Shaft Left	*	1
Cross Shaft Right	H 414235/H 414210	1
Differential Left	*	1
Differential Right	766/753 A	1
Bevel Pinion Rear	6466/6420	1
Bevel Pinion Front	65225/65500	1

FDRK 213 OB		
Differential Left	42381/42584	1
Differential Right	495/493	1
Bevel Pinion Rear	55200 C/55437	1
Bevel Pinion Pilot	F 19083	1
Bevel Pinion Front	55200 C/55437	1

FDRK 214 OB		
Differential Left	JM 822049/JM 822010	1
Differential Right	JM 716649/JM 716610	1
Bevel Pinion Rear	72225 C/72487	1
Bevel Pinion Pilot	F 19084	1
Bevel Pinion Front	55200 C/55437	1

POSITION	FERSA	QTY
FDRK 216 OB		
Differential Left	42381/42584	1
Differential Right	JLM 714149/JLM 714110	1
Bevel Pinion Rear	55200 C/55437	1
Bevel Pinion Pilot	F 19035	1
Bevel Pinion Front	M 804049/M 804010	1

FDRK 217F OB		
Differential Left	JM 716649/JM 716610	1
Differential Right	JM 716649/JM 716610	1
Input Shaft Front	JM 511946/JM 511910	1
Input Shaft Rear	JLM 710949 C/JLM 710910	1
Output Shaft	LM 104949/JLM 104910	2
Bevel Pinion Rear	H 715334/H 715311	1
Bevel Pinion Front	72212 C/72487	1

FDRK 217R OB		
Differential Left	JM 716649/JM 716610	1
Differential Right	JM 716649/JM 716610	1
Bevel Pinion Rear	72212 C/72487	1
Bevel Pinion Pilot	F 19035	1
Bevel Pinion Front	55206 C/55437	1

FDRK 218 OB		
Differential Left	3994/JM 511910	1
Differential Right	34306/34478	1
Bevel Pinion Rear	55200 C/55437	1
Bevel Pinion Pilot	*	1
Bevel Pinion Front	HM 804846/HM 804810	1

FDRK 219R OB		
Differential Left	68462/68712	1
Differential Right	42381/42584	1
Bevel Pinion Rear	78215 C/78551	1
Bevel Pinion Pilot	F 19084	1
Bevel Pinion Front	72212 C/72487	1

FDRK 220F OB		
Differential Left	42381/42584	1
Differential Right	68450/68712	1
Input Shaft Front	JM 511946/JM 511910	1
Input Shaft Rear	JH 211749/JH 211710	1
Output Shaft	*	1
Pinion Forward	*	1
Bevel Pinion Rear	72212 C/72487	1
Bevel Pinion Pilot	F 19084	1
Bevel Pinion Front	72212 C/72487	1

POSITION	FERSA	QTY
FDRK 220FA OB		
Differential Left	42381/42584	1
Differential Right	68462/68712	1
Input Shaft Front	JM 511946/JM 511910	1
Input Shaft Rear	JH 211749/JH 211710	1
Output Shaft	*	1
Pinion Forward	*	1
Bevel Pinion Rear	72212 C/72487	1
Bevel Pinion Pilot	F 19084	1
Bevel Pinion Front	72212 C/72487	1

FDRK 221 OB		
Differential Left	497/493	1
Differential Right	3994/3920	1
Bevel Pinion Rear	72200 C/72487	1
Bevel Pinion Pilot	*	1
Bevel Pinion Front	HM 903249/HM 903210	1

FDRK 222F OB		
Differential Left	497/493	1
Differential Right	567/563	1
Input Shaft	3979/JM 511910	1
Output Shaft Front	29675/29620	1
Output Shaft Rear	*	1
Bevel Pinion Rear	72218 C/72487	1
Bevel Pinion Pilot	*	1
Bevel Pinion Front	HM 807049/HM 807010	1

FDRK 222R OB		
Differential Left	567/563	1
Differential Right	497/493	1
Bevel Pinion Rear	72200 C/72487	1
Bevel Pinion Pilot	*	1
Bevel Pinion Front	55200 C/55437	1

FDRK 223F OB		
Differential Left	495/493	1
Differential Right	495/493	1
Input Gear	*	1
Input Shaft	HM 807049/HM 807010	1
Inter Axle	JLM 710949 C/JLM 710910	1
Output Shaft	*	1
Bevel Pinion Rear	72225 C/72487	1
Bevel Pinion Pilot	F 19035	1
Bevel Pinion Front	72225 C/72487	1

FDRK 223R OB		
Differential Left	495/493	1
Differential Right	495/493	1
Bevel Pinion Rear	72225 C/72487	1
Bevel Pinion Pilot	F 19035	1
Bevel Pinion Front	72225 C/72487	1

POSITION	FERSA	QTY
FDRK 224 OB		
Differential Left	32020 XF	1
Differential Right	32020 XF	1
Bevel Pinion Rear	72212 C/72487	1
Bevel Pinion Pilot	F 19035	1
Bevel Pinion Front	55206 C/55437	1

FDRK 225 OB		
Differential Left	52400/52618	1
Differential Right	JM 716649/JM 716610	1
Bevel Pinion Rear	HM 804846/HM 804810	1
Bevel Pinion Pilot	F 19100	1
Bevel Pinion Front	55200 C/55437	1

FDRK 400 OB		
Differential Left	497/493	1
Differential Right	3994/3920	1
Bevel Pinion Rear	55175 C/55437	1
Bevel Pinion Pilot	*	1
Bevel Pinion Front	HM 903249/HM 903210	1

FDRK 401 OB		
Differential Left	32024 XF	1
Differential Right	JM 822049/JM 822010	1
Bevel Pinion Rear	H 914841/H 914811	1
Bevel Pinion Pilot	*	1
Bevel Pinion Front	HM 813841/HM 813810	1

FDRK 402 OB		
Differential Left	52400/52618	1
Differential Right	JM 822049/JM 822010	1
Bevel Pinion Rear	H 914841/H 914811	1
Bevel Pinion Pilot	*	1
Bevel Pinion Front	HM 813841/HM 813810	1

FDRK 403 OB		
Differential Left	56425/56650	1
Differential Right	497/493	1
Bevel Pinion Rear	72200 C/72487	1
Bevel Pinion Pilot	F 19083	1
Bevel Pinion Front	55200 C/55437	1

FDRK 404F OB		
Differential Left	497/493	1
Differential Right	567/563	1
Input Shaft	5555/552 A	1
Output Shaft	29675/29630	1
Bevel Pinion Rear	72218 C/72487	1
Bevel Pinion Pilot	F 19100	1
Bevel Pinion Front	55212 C/55437	1

1.2 \ F-Box Differential Rebuild Kit

POSITION	FERSA	QTY
FDRK 404FA OB		
Differential Left	497/493	1
Differential Right	567/563	1
Input Shaft	5555/552 A	1
Output Shaft	29688/29620	1
Bevel Pinion Rear	72218 C/72487	1
Bevel Pinion Pilot	F 19100	1
Bevel Pinion Front	55212 C/55437	1

FDRK 404FAMK OB		
Differential Left	497/493	1
Differential Right	567/563	1
Input Shaft	5555/552 A	1
Output Shaft	29688/29620	1
Bevel Pinion Rear	72218 C/72487	1
Bevel Pinion Pilot	F 19100	1
Bevel Pinion Front	55212 C/55437	1

FDRK 404FMK OB		
Differential Left	497/493	1
Differential Right	567/563	1
Input Shaft	5555/552 A	1
Output Shaft	29675/29630	1
Bevel Pinion Rear	72218 C/72487	1
Bevel Pinion Pilot	F 19100	1
Bevel Pinion Front	55212 C/55437	1

FDRK 404R OB		
Differential Left	567/563	1
Differential Right	497/493	1
Bevel Pinion Rear	72212 C/72487	1
Bevel Pinion Pilot	F 19099	1
Bevel Pinion Front	55200 C/55437	1

FDRK 404RMK OB		
Differential Left	567/563	1
Differential Right	497/493	1
Bevel Pinion Rear	72212 C/72487	1
Bevel Pinion Pilot	F 19099	1
Bevel Pinion Front	55200 C/55437	1

FDRK 405F OB		
Differential Left	42362/42584	1
Differential Right	567/563	1
Input Shaft	5555/552 A	1
Output Shaft	29675/29630	1
Bevel Pinion Rear	72218 C/72487	1
Bevel Pinion Pilot	F 19100	1
Bevel Pinion Front	55212 C/55437	1

POSITION	FERSA	QTY
FDRK 405FA OB		
Differential Left	42362/42584	1
Differential Right	567/563	1
Input Shaft	5555/552 A	1
Output Shaft	29688/29620	1
Bevel Pinion Rear	72218 C/72487	1
Bevel Pinion Pilot	F 19100	1
Bevel Pinion Front	55212 C/55437	1

FDRK 405FAMK OB		
Differential Left	42362/42584	1
Differential Right	567/563	1
Input Shaft	5555/552 A	1
Output Shaft	29688/29620	1
Bevel Pinion Rear	72218 C/72487	1
Bevel Pinion Pilot	F 19100	1
Bevel Pinion Front	55212 C/55437	1
Thrushaft	LM 104949/JLM 104910	2

FDRK 405FMK OB		
Differential Left	42362/42584	1
Differential Right	567/563	1
Input Shaft	5555/552 A	1
Output Shaft	29675/29630	1
Bevel Pinion Rear	72218 C/72487	1
Bevel Pinion Pilot	F 19100	1
Bevel Pinion Front	55212 C/55437	1
Thrushaft	LM 104949/JLM 104910	2

FDRK 405R OB		
Differential Left	567/563	1
Differential Right	42362/42584	1
Bevel Pinion Rear	72212 C/72487	1
Bevel Pinion Pilot	F 19099	1
Bevel Pinion Front	55200 C/55437	1

FDRK 405RMK OB		
Differential Left	567/563	1
Differential Right	42362/42584	1
Bevel Pinion Rear	72212 C/72487	1
Bevel Pinion Pilot	F 19099	1
Bevel Pinion Front	55200 C/55437	1

FDRK 406 OB		
Differential Left	497/493	1
Differential Right	598/592 A	1
Bevel Pinion Rear	78215 C/78551	1
Bevel Pinion Pilot	F 19084	1
Bevel Pinion Front	55200 C/55437	1

POSITION	FERSA	QTY
FDRK 407 OB		
Differential Left	598/592 A	1
Differential Right	497/493	1
Bevel Pinion Rear	H 913842/H 913810	1
Bevel Pinion Pilot	F 19084	1
Bevel Pinion Front	72212 C/72487	1

POSITION	FERSA	QTY
FDRK 408 OB		
Differential Left	56425/56650	1
Differential Right	497/493	1
Bevel Pinion Rear	78215 C/78551	1
Bevel Pinion Pilot	F 19086	1
Bevel Pinion Front	72212 C/72487	1

POSITION	FERSA	QTY
FDRK 409 OB		
Differential Left	56425/56662	1
Differential Right	JM 822049/JM 822010	1
Bevel Pinion Rear	H 914841/H 914811	1
Bevel Pinion Pilot	*	1
Bevel Pinion Front	HM 813841/HM 813810	1

POSITION	FERSA	QTY
FDRK 410 OB		
Differential Left	598/592 A	1
Differential Right	497/493	1
Bevel Pinion Rear	H 914841/H 914811	1
Bevel Pinion Pilot	F 19033	1
Bevel Pinion Front	HM 813841/HM 813810	1

POSITION	FERSA	QTY
FDRK 411 OB		
Differential Left	498/493	1
Differential Right	33275/33472	1
Bevel Pinion Rear	5583/5535	1
Bevel Pinion Front	49576/49520	1

POSITION	FERSA	QTY
FDRK 411F OB		
Differential Left	495/493	1
Differential Right	495/493	1
Input Gear	*	1
Input Shaft	HM 807049/HM 807010	1
Inter Axle	JLM 710949 C/JLM 710910	1
Bevel Pinion Rear	72225 C/72487	1
Bevel Pinion Pilot	*	1
Bevel Pinion Front	72225 C/72487	1

POSITION	FERSA	QTY
FDRK 411R OB		
Differential Left	495/493	1
Differential Right	495/493	1
Bevel Pinion Rear	72225 C/72487	1
Bevel Pinion Pilot	*	1
Bevel Pinion Front	72225 C/72487	1

POSITION	FERSA	QTY
FDRK 412 OB		
Differential Left	567/563	1
Differential Right	497/493	1
Bevel Pinion Rear	72200 C/72487	1
Bevel Pinion Pilot	F 19083	1
Bevel Pinion Front	55200 C/55437	1

POSITION	FERSA	QTY
FDRK 413 OB		
Differential Left	68450/68712	1
Differential Right	42381/42584	1
Bevel Pinion Rear	78215 C/78551	1
Bevel Pinion Pilot	F 19084	1
Bevel Pinion Front	72212 C/72487	1

POSITION	FERSA	QTY
FDRK 414 OB		
Differential Left	3984/3920	1
Differential Right	3984/3920	1
Bevel Pinion Rear	72225 C/72487	1
Bevel Pinion Front	55175 C/55437	1

POSITION	FERSA	QTY
FDRK 415 OB		
Differential Left	665/653	1
Differential Right	42381/42584	1
Bevel Pinion Rear	72212 C/72487	1
Bevel Pinion Pilot	*	1
Bevel Pinion Front	72212 C/72487	1

POSITION	FERSA	QTY
FDRK 416 OB		
Differential Left	56425/56650	1
Differential Right	56425/56650	1
Bevel Pinion Rear	9185/9121	1
Bevel Pinion Pilot	F 19033	1
Bevel Pinion Front	H 715343/H 715311	1

POSITION	FERSA	QTY
FDRK 417 OB		
Differential Left	497/493	1
Differential Right	567/563	1
Front Output Shaft Front	3780/3720	1
Front Output Shaft Rear	LM 501349/LM 501310	1
Input Shaft Front	3979/JM 511910	1
Input Shaft Rear	3979/3920	1
Outer Pinion Support	*	1
Bevel Pinion Rear	72218 C/72487	1
Bevel Pinion Pilot	F 19083	1
Bevel Pinion Front	HM 807049/HM 807010	1

1.2 \ F-Box Differential Rebuild Kit

POSITION	FERSA	QTY
FDRK 418 OB		
Differential Left	42381/42584	1
Differential Right	665/653	1
Front Output Shaft Front	3979/3920	1
Front Output Shaft Rear	3872/3820	1
Input Shaft Front	JH 211749/JH 211710	1
Input Shaft Rear	JM 511946/JM 511910	1
Outer Pinion Support	*	1
Bevel Pinion Rear	72212 C/72487	1
Bevel Pinion Pilot	F 19084	1
Bevel Pinion Front	72212 C/72487	1

FDRK 419 OB		
Differential Left	56425/56650	1
Differential Right	497/493	1
Front Output Shaft Front	3780/3720	1
Front Output Shaft Rear	LM 501349/LM 501310	1
Input Shaft Front	3979/JM 511910	1
Input Shaft Rear	3979/3920	1
Outer Pinion Support	*	1
Bevel Pinion Rear	72218 C/72487	1
Bevel Pinion Pilot	F 19083	1
Bevel Pinion Front	HM 807049/HM 807010	1

FDRK 420 OB		
Differential Left	68462/68712	1
Differential Right	42381/42584	1
Front Output Shaft Front	3979/3920	1
Front Output Shaft Rear	3872/3820	1
Input Shaft Front	JH 211749/JH 211710	1
Input Shaft Rear	JM 511946/JM 511910	1
Outer Pinion Support	*	1
Bevel Pinion Rear	72212 C/72487	1
Bevel Pinion Pilot	F 19084	1
Bevel Pinion Front	72212 C/72487	1

FDRK 421 OB		
Differential Left	68462/68712	1
Differential Right	42346/42584	1
Front Output Shaft Front	3979/3920	1
Front Output Shaft Rear	3872/3820	1
Input Shaft Front	JH 211749/JH 211710	1
Input Shaft Rear	JM 511946/JM 511910	1
Outer Pinion Support	*	1
Bevel Pinion Rear	72212 C/72487	1
Bevel Pinion Pilot	F 19084	1
Bevel Pinion Front	72212 C/72487	1

POSITION	FERSA	QTY
FDRK 422 OB		
Differential Left	497/493	1
Differential Right	567/563	1
Front Output Shaft Front	3780/3720	1
Front Output Shaft Rear	LM 501349/LM 501310	1
Input Shaft Front	3979/JM 511910	1
Input Shaft Rear	29675/29620	1
Outer Pinion Support	*	1
Bevel Pinion Rear	72218 C/72487	1
Bevel Pinion Pilot	F 19083	1
Bevel Pinion Front	HM 807049/HM 807010	1
Rear Output Shaft	*	1

FDRK 423 OB		
Differential Left	42381/42584	1
Differential Right	665/653	1
Front Output Shaft Front	3979/3920	1
Front Output Shaft Rear	HM 88649/HM 88610	1
Input Shaft Front	JM 511946/JM 511910	1
Input Shaft Rear	33275/33472	1
Outer Pinion Support	*	1
Bevel Pinion Rear	72212 C/72487	1
Bevel Pinion Pilot	F 19084	1
Bevel Pinion Front	72212 C/72487	1
Rear Output Shaft	*	1

FDRK 424 OB		
Differential Left	497/493	1
Differential Right	56425/56650	1
Front Output Shaft Front	3780/3720	1
Front Output Shaft Rear	LM 501349/LM 501310	1
Input Shaft Front	3979/JM 511910	1
Input Shaft Rear	29675/29620	1
Outer Pinion Support	*	1
Bevel Pinion Rear	72218 C/72487	1
Bevel Pinion Pilot	F 19083	1
Bevel Pinion Front	HM 807049/HM 807010	1
Rear Output Shaft	*	1

POSITION	FERSA	QTY
FDRK 425 OB		
Differential Left	68462/68712	1
Differential Right	42381/42584	1
Front Output Shaft Front	3979/3920	1
Front Output Shaft Rear	HM 88649/HM 88610	1
Input Shaft Front	JM 511946/JM 511910	1
Input Shaft Rear	33275/33472	1
Outer Pinion Support	*	1
Bevel Pinion Rear	72212 C/72487	1
Bevel Pinion Pilot	F 19084	1
Bevel Pinion Front	72212 C/72487	1
Rear Output Shaft	*	1

FDRK 426 OB		
Differential Left	68462/68712	1
Differential Right	42346/42584	1
Front Output Shaft Front	3979/3920	1
Front Output Shaft Rear	HM 88649/HM 88610	1
Input Shaft Front	JM 511946/JM 511910	1
Input Shaft Rear	33275/33472	1
Outer Pinion Support	*	1
Bevel Pinion Rear	72212 C/72487	1
Bevel Pinion Pilot	F 19084	1
Bevel Pinion Front	72212 C/72487	1
Rear Output Shaft	*	1

FDRK 427 OB		
Differential Left Cone	*	1
Differential Left Cup	*	1
Differential Right	*	1
Input Shaft Front	*	1
Input Shaft Rear	29675/29630	1
Output Shaft Front	LM 104949/JLM 104910	1
Output Shaft Rear	LM 104949/JLM 104910	1
Bevel Pinion Rear	*	1
Bevel Pinion Pilot	F 19100	1
Bevel Pinion Front	55212 C/55437	1

FDRK 427A OB		
Differential Left Cone	*	1
Differential Left Cup	*	1
Differential Right	*	1
Input Shaft Front	*	1
Input Shaft Rear	29688/29620	1
Output Shaft Front	LM 104949/JLM 104910	1
Output Shaft Rear	LM 104949/JLM 104910	1
Bevel Pinion Rear	*	1
Bevel Pinion Pilot	F 19100	1
Bevel Pinion Front	55212 C/55437	1

POSITION	FERSA	QTY
FDRK 428 OB		
Differential Left	42362/42584	1
Differential Right	*	1
Input Shaft Front	*	1
Input Shaft Rear	29675/29630	1
Output Shaft Front	LM 104949/JLM 104910	1
Output Shaft Rear	LM 104949/JLM 104910	1
Bevel Pinion Rear	*	1
Bevel Pinion Pilot	F 19100	1
Bevel Pinion Front	55212 C/55437	1

FDRK 428A OB		
Differential Left	42362/42584	1
Differential Right	*	1
Input Shaft Front	*	1
Input Shaft Rear	29688/29620	1
Output Shaft Front	LM 104949/JLM 104910	1
Output Shaft Rear	LM 104949/JLM 104910	1
Bevel Pinion Rear	*	1
Bevel Pinion Pilot	F 19100	1
Bevel Pinion Front	55212 C/55437	1

FDRK 429 OB		
Differential Left Cone	*	1
Differential Left Cup	*	1
Differential Right	*	1
Bevel Pinion Rear	*	1
Bevel Pinion Pilot	F 19099	1
Bevel Pinion Front	55200 C/55437	1

FDRK 430 OB		
Differential Left	42362/42584	1
Differential Right	*	1
Bevel Pinion Rear	*	1
Bevel Pinion Pilot	F 19099	1
Bevel Pinion Front	55200 C/55437	1

FDRK 431 OB		
Differential Left	42381/42584	1
Differential Right	665/653	1
Input Shaft Front	JM 511946/JM 511910	1
Outer Pinion Support (Aft 2/2000)	*	1
Outer Pinion Support (Pre 2/2000)	*	1
Output Shaft Front	33275/33472	1
Output Shaft Rear	*	1
Bevel Pinion Rear	*	1
Bevel Pinion Pilot	F 19084	1
Bevel Pinion Front	*	1

1.2 \ F-Box Differential Rebuild Kit

POSITION	FERSA	QTY
FDRK 432 OB		
Differential Left	42381/42584	1
Differential Right	68462/68712	1
Input Shaft	JM 511946/JM 511910	1
Outer Pinion Support	*	1
Output Shaft Front	33275/33472	1
Output Shaft Rear	*	1
Bevel Pinion Rear	72212 C/72487	1
Bevel Pinion Pilot	F 19084	1
Bevel Pinion Front	72212 C/72487	1

FDRK 433 OB		
Differential Left	42381/42584	1
Differential Right	665/653	1
Input Shaft	JM 511946/JM 511910	1
Outer Pinion Support	*	1
Output Shaft Front	33275/33472	1
Output Shaft Rear	*	1
Bevel Pinion Rear	72212 C/72487	1
Bevel Pinion Pilot	F 19084	1
Bevel Pinion Front	72212 C/72487	1

FDRK 434 OB		
Differential Left	3984/3920	1
Differential Right	3984/3920	1
Bevel Pinion Rear	72212 C/72487	1
Bevel Pinion Front	55200 C/55437	1

FDRK 435 OB		
Differential Left	42381/42584	1
Differential Right	68462/68712	1
Input Shaft Front	JM 511946/JM 511910	1
Outer Pinion Support (Aft 2/2000)	*	1
Outer Pinion Support (Pre 2/2000)	*	1
Output Shaft Front	33275/33472	1
Output Shaft Rear	*	1
Bevel Pinion Rear	*	1
Bevel Pinion Pilot	F 19084	1
Bevel Pinion Front	*	1

FDRK 436 OB		
Differential Left Cone	CONE 64452 A	1
Differential Left Cup	*	1
Differential Right Cone	CONE F 15362	1
Differential Right Cup	*	1
Input Shaft Front	HM 813844/HM 813810	1
Input Shaft Rear	JM 714249/JM 714210	1
Bevel Pinion Rear	F 15328	1
Bevel Pinion Front	65237/65500	1

POSITION	FERSA	QTY
FDRK 436A OB		
Differential Left	*	1
Differential Right Cone	CONE 33024 F	1
Differential Right Cup	*	1
Input Shaft Front	HM 813844/HM 813810	1
Input Shaft Rear	JM 714249/JM 714210	1
Bevel Pinion Rear	F 15328	1
Bevel Pinion Front	65237/65500	1

FDRK 437 OB		
Differential Left Cone	CONE 64452 A	1
Differential Left Cup	*	1
Differential Right Cone	CONE F 15362	1
Differential Right Cup	*	1
Input Shaft Front	HM 813844/HM 813810	1
Input Shaft Rear	JM 714249/JM 714210	1
Bevel Pinion Rear	F 15328	1
Bevel Pinion Pilot	*	1
Bevel Pinion Front	65237/65500	1

FDRK 437A OB		
Differential Left	*	1
Differential Right Cone	CONE 33024 F	1
Differential Right Cup	*	1
Input Shaft Front	HM 813844/HM 813810	1
Input Shaft Rear	JM 714249/JM 714210	1
Bevel Pinion Rear	F 15328	1
Bevel Pinion Pilot	*	1
Bevel Pinion Front	65237/65500	1

FDRK 438 OB		
Differential Left Cone	CONE 64452 A	1
Differential Left Cup	*	1
Differential Right Cone	CONE 64452 A	1
Differential Right Cup	*	1
Bevel Pinion Rear	F 15328	1
Bevel Pinion Pilot	*	1
Bevel Pinion Front	F 15327	1

FDRK 438A OB		
Differential Left	*	1
Differential Right	*	1
Bevel Pinion Rear	F 15328	1
Bevel Pinion Pilot	*	1
Bevel Pinion Front	F 15327	1

FDRK 439 OB		
Differential Left Cone	CONE 64452 A	1
Differential Left Cup	*	1
Differential Right Cone	CONE 64452 A	1
Differential Right Cup	*	1
Bevel Pinion Rear	F 15328	1
Bevel Pinion Front	F 15327	1

POSITION	FERSA	QTY
FDRK 439A OB		
Differential Left	*	1
Differential Right	*	1
Bevel Pinion Rear	F 15328	1
Bevel Pinion Front	F 15327	1

FDRK 441 OB		
Differential Left Cone	CONE 64452 A	1
Differential Left Cup	*	1
Differential Right Cone	CONE F 15362	1
Differential Right Cup	*	1
Bevel Pinion Rear	F 15328	1
Bevel Pinion Pilot	F 19084	1
Bevel Pinion Front	F 15327	1

FDRK 441A OB		
Differential Left	*	1
Differential Right Cone	CONE 33024 F	1
Differential Right Cup	*	1
Bevel Pinion Rear	F 15328	1
Bevel Pinion Pilot	F 19084	1
Bevel Pinion Front	F 15327	1

FDRK 442 OB		
Differential Left Cone	CONE 64452 A	1
Differential Left Cup	*	1
Differential Right Cone	CONE 64452 A	1
Differential Right Cup	*	1
Input Shaft Front	HM 813844/HM 813810	1
Input Shaft Rear	JM 714249/JM 714210	1
Bevel Pinion Rear	F 15328	1
Bevel Pinion Front	65237/65500	1

FDRK 442A OB		
Differential Left	*	1
Differential Right	*	1
Input Shaft Front	HM 813844/HM 813810	1
Input Shaft Rear	JM 714249/JM 714210	1
Bevel Pinion Rear	F 15328	1
Bevel Pinion Front	65237/65500	1

FDRK 443 OB		
Differential Left Cone	CONE 64452 A	1
Differential Left Cup	*	1
Differential Right Cone	CONE F 15362	1
Differential Right Cup	*	1
Bevel Pinion Rear	F 15328	1
Bevel Pinion Pilot	*	1
Bevel Pinion Front	F 15327	1

POSITION	FERSA	QTY
FDRK 443A OB		
Differential Left	*	1
Differential Right Cone	CONE 33024 F	1
Differential Right Cup	*	1
Bevel Pinion Rear	F 15328	1
Bevel Pinion Pilot	*	1
Bevel Pinion Front	F 15327	1

FDRK 444 OB		
Differential Left Cone	CONE 64452 A	1
Differential Left Cup	*	1
Differential Right Cone	CONE F 15362	1
Differential Right Cup	*	1
Bevel Pinion Rear	F 15328	1
Bevel Pinion Front	F 15327	1
Bevel Pinion Front	F 15327	1

FDRK 444A OB		
Differential Left	*	1
Differential Right Cone	CONE 33024 F	1
Differential Right Cup	*	1
Bevel Pinion Rear	F 15328	1
Bevel Pinion Front	F 15327	1

FDRK 445 OB		
Differential Left Cone	*	1
Differential Right Cup	*	1
Differential Right	567/563	1
Bevel Pinion Rear	*	1
Bevel Pinion Pilot	F 19099	1
Bevel Pinion Front	55200 C/55437	1

FDRK 446 OB		
Differential Left Cone	*	1
Differential Left Cup	*	1
Differential Right	567/563	1
Bevel Pinion Rear	*	1
Bevel Pinion Pilot	*	1
Bevel Pinion Front	55200 C/55437	1

FDRK 447 OB		
Differential Left Cone	*	1
Differential Left Cup	*	1
Differential Right	567/563	1
Bevel Pinion Rear	*	1
Bevel Pinion Pilot	F 19099	1
Bevel Pinion Front	55200 C/55437	1

1.2 \ F-Box Differential Rebuild Kit

POSITION	FERSA	QTY
FDRK 448 OB		
Differential Left Cone	*	1
Differential Left Cup	*	1
Differential Right	567/563	1
Bevel Pinion Rear	*	1
Bevel Pinion Pilot	*	1
Bevel Pinion Front	55200 C/55437	1

FDRK 449 OB		
Differential Left	665/653	1
Differential Right	42381/42584	1
Bevel Pinion Rear	78215 C/78551	1
Bevel Pinion Pilot	F 19084	1
Bevel Pinion Front	72212 C/72487	1

FDRK 451 OB		
Differential Right	497/493	1
Differential Left	598/592 A	1
Bevel Pinion Rear	H 715343/H 715311	1
Bevel Pinion Front	HM 813841/HM 813810	1
Bevel Pinion Pilot	*	1

FDRK 452 OB		
Differential Right	3984/3920	1
Differential Left	594 A/592 A	1
Bevel Pinion Rear	*	1
Bevel Pinion Front	55200 C/55437	1

FDRK 453 OB		
Differential Right Cone	CONE F 15362	1
Differential Right Cup	*	1
Differential Left Cone	CONE 64452 A	1
Differential Left Cup	*	1
Bevel Pinion Rear	F 15328	1
Bevel Pinion Front	65237/65500	1
Bevel Pinion Pilot	*	1
Input Shaft Front	HM 813844/HM 813810	1
Input Shaft Rear	JM 714249/JM 714210	1

FDRK 453A OB		
Differential Right Cone	CONE 33024 F	1
Differential Right Cup	*	1
Differential Left	*	1
Bevel Pinion Rear	F 15328	1
Bevel Pinion Front	65237/65500	1
Bevel Pinion Pilot	*	1
Input Shaft Front	HM 813844/HM 813810	1
Input Shaft Rear	JM 714249/JM 714210	1

POSITION	FERSA	QTY
FDRK 454 OB		
Differential Left Cone	CONE 64452 A	1
Differential Left Cup	*	1
Differential Right Cone	CONE 64452 A	1
Differential Right Cup	*	1
Bevel Pinion Rear	F 15328	1
Bevel Pinion Front	65237/65500	1
Input Shaft Front	HM 813844/HM 813810	1
Input Shaft Rear	JM 714249/JM 714210	1

FDRK 454A OB		
Differential Right	*	1
Differential Left	*	1
Bevel Pinion Rear	F 15328	1
Bevel Pinion Front	65237/65500	1
Input Shaft Front	HM 813844/HM 813810	1
Input Shaft Rear	JM 714249/JM 714210	1

FDRK 500 OB		
Cross Shaft Left	H 715345/H 715311	1
Cross Shaft Right	H 715334/H 715311	1
Differential Left	*	1
Differential Right	47687/47623 A	1
Input Shaft	6213 NR	1
Inter Axle	6211	1
Bevel Pinion Rear	596/592 A	1
Bevel Pinion Front	H 715348/H 715311	1

FDRK 501 OB		
Cross Shaft Left	H 715345/H 715311	1
Cross Shaft Right	H 715334/H 715311	1
Differential Left	*	1
Differential Right	47687/47623 A	1
Bevel Pinion Rear	6466/6420	1
Bevel Pinion Front	H 715334/H 715311	1

FDRK 502 OB		
Cross Shaft Left	*	1
Cross Shaft Right	624/612	1
Differential Left	*	1
Differential Right	47681/47623 A	1
Bevel Pinion Rear	5760/5735	1
Bevel Pinion Front	49585/49520	1

FDRK 503 OB		
Cross Shaft Left	*	1
Cross Shaft Right	621/612	1
Differential Left	*	1
Differential Right	47687/47623 A	1
Bevel Pinion Rear	5760/5735	1
Bevel Pinion Front	559/552 A	1

POSITION	FERSA	QTY
FDRK 504 OB		
Cross Shaft Left	645 X/634W	1
Cross Shaft Right	624/612	1
Differential Left	*	1
Differential Right	*	1
Input Shaft	6310	1
Inter Axle	6309	1
Bevel Pinion Rear	643/632	1
Bevel Pinion Front	559/552 A	1
Power Divider	*	1

FDRK 505 OB		
Cross Shaft Left	645 X/634W	1
Cross Shaft Right	624/612	1
Differential Left	*	1
Differential Right	*	1
Bevel Pinion Rear	643/632	1
Bevel Pinion Front	555/552 A	1

FDRK 506 OB		
Cross Shaft Left	*	1
Cross Shaft Right	*	1
Differential Left	*	1
Differential Right	*	1
Bevel Pinion Rear	6460/6420	1
Bevel Pinion Front	65225/65550	1

FDRK 507 OB		
Cross Shaft Left	*	1
Cross Shaft Right	621/612	1
Differential Left	*	1
Differential Right	47687/47623 A	1
Input Shaft	6213 NR	1
Bevel Pinion Rear	HM 518437/HM 518411	1
Bevel Pinion Front	495S/492 A	1
Thrushaft	6211	1

FDRK 508 OB		
Cross Shaft Left	*	1
Cross Shaft Right	621/612	1
Differential Left	*	1
Differential Right	47687/47623 A	1
Bevel Pinion Rear	HM 518437/HM 518411	1
Bevel Pinion Front	495S/492 A	1

FDRK 600 OB		
Differential Left	495/493	1
Differential Right	495/493	1
Bevel Pinion Rear	72225 C/72487	1
Bevel Pinion Pilot	F 19100	1
Bevel Pinion Front	66212/66462	1

POSITION	FERSA	QTY
FDRK 601 OB		
Differential Left	33214 F	1
Differential Right	*	1
Bevel Pinion Rear	*	1
Bevel Pinion Front	*	1

FDRK 650F OB		
Differential Left	32017 XF	1
Differential Right	32022 XF	1
Helical Gear Needle	*	2
Helical Gear Thrust	*	1
Input Shaft Front	JM 511945/3920	1
Input Shaft Rear	JLM 714149/JLM 714110	1
Bevel Pinion Rear	F 15255	1
Bevel Pinion Front	F 15256	1

FDRK 650FA OB		
Differential Left	32017 XF	1
Differential Right	32022 XF	1
Helical Gear Needle	*	1
Helical Gear Thrust	*	1
Input Shaft Front	*	1
Input Shaft Rear	JLM 714149/JLM 714110	1
Bevel Pinion Rear	F 15255	1
Bevel Pinion Front	F 15256	1

FDRK 650R OB		
Differential Left	32017 XF	1
Differential Right	32022 XF	1
Bevel Pinion Rear	F 15255	1
Bevel Pinion Front	F 15256	1

FDRK 651 OB		
Differential Left	32014 XF	1
Differential Right	32020 XF	1
Bevel Pinion Rear	JW 6049/JW 6010	1
Bevel Pinion Front	JW 6049/JW 6010	1

FDRK 700 OB		
Differential Left	388 A/382	1
Differential Right	388 A/382	1
Bevel Pinion Rear and Tail	*	1
Bevel Pinion Pilot	*	1
Differential Left	28990/28919	1
Differential Right	28990/28919	1
Bevel Pinion Rear	*	1
Bevel Pinion Front	*	1

FDRK 701 OB		
Differential Left	28990/28919	1
Differential Right	28990/28919	1
Pinion Head	*	1
Pinion Tail	*	1

1.2 \ F-Box Differential Rebuild Kit

POSITION	FERSA	QTY
FDRK 702 OB		
Differential Left	*	1
Differential Right	*	1
Bevel Pinion Rear and Tail	*	1
Bevel Pinion Pilot	*	1

FDRK 801 OB		
Differential Left	594/592 A	1
Differential Right	594/592 A	1
Input Shaft Front	30214 F	1
Input Shaft Front Needle	*	1
Input Shaft Rear	JLM 714149/JLM 714110	1
Input Shaft Rear Needle	*	1
Output Shaft	6310	1
Bevel Pinion Rear	31315 F	1
Bevel Pinion Pilot	F 19034	1
Bevel Pinion Front	HM 911245/HM 911210	1

FDRK 802 OB		
Differential Left	594/592 A	1
Differential Right	594/592 A	1
Bevel Pinion Rear	H 913843/H 913810	1
Bevel Pinion Pilot	F 19034	1
Bevel Pinion Front	HM 911245/HM 911210	1

FDRK 900F OB		
Differential Left	497/493	1
Differential Right	496/493	1
Drive Gear Front	29675/29630	1
Drive Gear Rear	29675/29630	1
Idler Gear Cone	CONE 31597	2
Idler Gear Cup	CONE 31520	2
Input Shaft	*	1
Bevel Pinion Rear	72200 C/72487	1
Bevel Pinion Pilot	F 19035	1
Bevel Pinion Front	72200 C/72487	1
Thrushaft	LM 603049/LM 603011	2

FDRK 900FA OB		
Differential Left	497/493	1
Differential Right	496/493	1
Drive Gear Front	29675/29630	1
Drive Gear Rear	29675/29630	1
Idler Gear	31597/31520	2
Input Shaft	*	1
Bevel Pinion Rear	72200 C/72487	1
Bevel Pinion Pilot	F 19035	1
Bevel Pinion Front	72200 C/72487	1
Thrushaft	LM 603049/LM 603011	2

POSITION	FERSA	QTY
FDRK 1910 OB		
Cross Shaft Left	*	1
Cross Shaft Right	641/632	2
Differential Left	683/672	1
Differential Right	683/672	1
Bevel Pinion Rear	42350/42584	1
Bevel Pinion Front	42350/42584	1
Rear Pinion	*	1

FDRK 1918 OB		
Differential Left	33281/33472	1
Differential Right	33281/33472	1
Bevel Pinion Rear	55187 C/55443	1
Bevel Pinion Pilot	F 19035	1
Bevel Pinion Front	55176 C/55443	1

FDRK 1925 OB		
Cross Shaft Left	65225/65500	1
Cross Shaft Right	65225/65500	1
Differential Left	47686/47620	1
Differential Right	47686/47620	1
Bevel Pinion Rear	H 715345/H 715311	1
Bevel Pinion Front	HM 807046/HM 807010	1

FDRK 1925A OB		
Cross Shaft Left	65225/65500	1
Cross Shaft Right	65225/65500	1
Differential Left	HM 516449 C/HM 516410	1
Differential Right	HM 516449 C/HM 516410	1
Bevel Pinion Rear	H 715345/H 715311	1
Bevel Pinion Front	HM 807046/HM 807010	1

FDRK 1926 OB		
Differential Left	42688/42620	1
Differential Right	34301/34500	1
Bevel Pinion Rear	55200 C/55437	1
Bevel Pinion Pilot	F 19035	1
Bevel Pinion Front	55187 C/55437	1

FDRK 1984 OB		
Differential Left	47890/47820	1
Differential Right	47890/47820	1
Idler Gear Front	49585/49520	1
Idler Gear Rear	HM 807046/HM 807010	1
Input Shaft Front	3767/3720	1
Input Shaft Rear	3775/3720	1
Bevel Pinion Rear	H 715343/H 715311	1
Bevel Pinion Pilot	F 19034	1
Bevel Pinion Front	H 715343/H 715311	1

POSITION	FERSA	QTY
FDRK 2108 OB		
Differential Left	687/672	1
Differential Right	687/672	1
Bevel Pinion Rear	HM 813844/HM 813810	1
Bevel Pinion Pilot	*	1
Bevel Pinion Front	H 715341/H 715311	1

FDRK 2111 OB		
Differential Left	395/394 A	1
Differential Right	395/394 A	1
Bevel Pinion Rear	M 903345/M 903310	1
Bevel Pinion Pilot	F 19040	1
Bevel Pinion Front	44143/44348	1

FDRK 4095 OB		
Differential Left	47890/47820	1
Differential Right	47890/47820	1
Input Shaft	JH 211749/JH 211710	1
Inter Differential	JLM 714149/JLM 714110	1
Output Shaft	LM 104949/JLM 104910	2
Bevel Pinion Rear	H 715343/H 715311	1
Bevel Pinion Front	65237/65500	1

FDRK 4100 OB		
Differential Left	47890/47820	1
Differential Right	47890/47820	1
Input Shaft	JH 211749/JH 211710	1
Inter Differential	JLM 714149/JLM 714110	1
Bevel Pinion Rear	H 715343/H 715311	1
Bevel Pinion Front	65237/65500	1
Thrushaft	6210	1

FDRK 4105 OB		
Differential Left	47890/47820	1
Differential Right	47890/47820	1
Bevel Pinion Rear	H 715343/H 715311	1
Bevel Pinion Pilot	F 19084	1
Bevel Pinion Front	H 715334/H 715311	1
Differential Left	52387/52618	1

FDRK 4125 OB		
Differential Right	598/592 A	1
Input Shaft Front	HM 813841/HM 813810	1
Input Shaft Rear	JM 515649/JM 515610	1
Oil Pump Idler Gear	*	1
Bevel Pinion Rear	78250 AC/78551	1
Bevel Pinion Pilot	*	1
Bevel Pinion Front	78250 AC/78551	1
Thrushaft	385 A/382 A	2

POSITION	FERSA	QTY
FDRK 4130 OB		
Differential Left	52387/52618	1
Differential Right	598/592 A	1
Bevel Pinion Rear	H 715343/H 715311	1
Bevel Pinion Pilot	*	1
Bevel Pinion Front	H 715334/H 715311	1

FDRK 4135 OB		
Differential Left	52387/52618	1
Differential Right	598/592 A	1
Input Shaft Front	HM 813844/HM 813810	1
Input Shaft Rear	JM 515649/JM 515610	1
Oil Pump Idler Gear	*	1
Bevel Pinion Rear	78250 AC/78551	1
Bevel Pinion Pilot	*	1
Bevel Pinion Front	78250 AC/78551	1
Thrushaft	385 A/382 A	2

FDRK 4140 OB		
Differential Left	52387/52618	1
Differential Right	598/592 A	1
Input Shaft Front	HM 813844/HM 813810	1
Input Shaft Rear	JM 515649/JM 515610	1
Oil Pump Idler Gear	*	1
Bevel Pinion Rear	78250 AC/78551	1
Bevel Pinion Pilot	*	1
Bevel Pinion Front	78250 AC/78551	1
Thrushaft	385 A/382 A	2

FDRK 4145 OB		
Differential Left	52387/52618	1
Differential Right	598/592 A	1
Input Shaft Front	HM 813844/HM 813810	1
Input Shaft Rear	JM 515649/JM 515610	1
Oil Pump Idler Gear	*	1
Bevel Pinion Rear	78250 AC/78551	1
Bevel Pinion Pilot	*	1
Bevel Pinion Front	78250 AC/78551	1
Thrushaft	385 A/382 A	2

FDRK 4150 OB		
Differential Left	52387/52618	1
Differential Right	598/592 A	1
Bevel Pinion Rear	H 715343/H 715311	1
Bevel Pinion Pilot	*	1
Bevel Pinion Front	H 715334/H 715311	1

FDRK 4155 OB		
Differential Left	52387/52618	1
Differential Right	598/592 A	1
Input Shaft Front	496/493	1
Input Shaft Rear	29685/29620	1
Bevel Pinion Rear	78250 AC/78551	1
Bevel Pinion Pilot	*	1
Bevel Pinion Front	78250 AC/78551	1

1.2 \ F-Box Differential Rebuild Kit

POSITION	FERSA	QTY
FDRK 4155A OB		
Differential Left	52387/52618	1
Differential Right	598/592 A	1
Input Shaft Front	496/493	1
Input Shaft Rear	29685/29620	1
Bevel Pinion Rear	78250 AC/78551	1
Bevel Pinion Pilot	*	1
Bevel Pinion Front	78250 AC/78551	1

FDRK 4180 OB		
Cross Shaft Left	*	1
Cross Shaft Right	*	1
Cross Shaft Right	66225/66462	2
Differential Left	581/572	1
Differential Right	581/572	1
Bevel Pinion Rear	42350/42584	1
Bevel Pinion Pilot	*	1
Bevel Pinion Front	497/493	1
Thrushaft	6210	1

FDRK 4190 OB		
Cross Shaft Left	*	1
Cross Shaft Right	66225/66462	2
Differential Left	HM 516449 C/HM 516410	1
Differential Right	HM 516449 C/HM 516410	1
Bevel Pinion Rear	42350/42584	1
Bevel Pinion Pilot	*	1
Bevel Pinion Front	497/493	1

FDRK 4220 OB		
Cross Shaft Left	*	1
Cross Shaft Right	66225/66462	2
Differential Left	HM 516449 C/HM 516410	1
Differential Right	HM 516449 C/HM 516410	1
Input Shaft	394 A/392	2
Bevel Pinion Rear	42350/42584	1
Bevel Pinion Pilot	*	1
Bevel Pinion Front	497/493	1
Thrushaft	385 A/382 A	2

FDRK 4240 OB		
Cross Shaft Left	*	1
Cross Shaft Right	641/632	2
Differential Left	HM 516449 C/HM 516410	1
Differential Right	HM 516449 C/HM 516410	1
Bevel Pinion Rear	42350/42584	1
Bevel Pinion Pilot	*	1
Bevel Pinion Front	497/493	1

POSITION	FERSA	QTY
FDRK 4245 OB		
Cross Shaft Left	*	1
Cross Shaft Right	641/632	2
Differential Left	HM 516449 C/HM 516410	1
Differential Right	HM 516449 C/HM 516410	1
Input Shaft	387 A/382 A	1
Bevel Pinion Rear	42350/42584	1
Bevel Pinion Pilot	*	1
Bevel Pinion Front	497/493	1
Thrushaft	6210	1

FDRK 4255 OB		
Cross Shaft Left	*	1
Cross Shaft Right	641/632	2
Differential Left	683/672	1
Differential Right	683/672	1
Input Shaft	*	1
Bevel Pinion Rear	42350/42584	1
Bevel Pinion Pilot	*	1
Bevel Pinion Front	42350/42584	1
Thrushaft	6212	1

FDRK 4260 OB		
Cross Shaft Left	*	1
Cross Shaft Right	641/632	2
Differential Left	683/672	1
Differential Right	683/672	1
Input Shaft	394 A/392	2
Bevel Pinion Rear	42350/42584	1
Bevel Pinion Pilot	*	1
Bevel Pinion Front	42350/42584	1
Thrushaft	385 A/382 A	2

FDRK 4270 OB		
Cross Shaft Left	*	1
Cross Shaft Right	641/632	2
Differential Left	683/672	1
Differential Right	683/672	1
Bevel Pinion Rear	42350/42584	1
Bevel Pinion Pilot	*	1
Bevel Pinion Front	497/493	1

FDRK 4290 OB		
Differential Left	3994/JM 511910	1
Differential Right	3994/JM 511910	1
Bevel Pinion Rear	HM 903244/HM 903210	1
Bevel Pinion Pilot	F 19040	1
Bevel Pinion Front	44143/44348	1

POSITION	FERSA	QTY
FDRK 4295 OB		
Differential Left	3994/JM 511910	1
Differential Right	3994/JM 511910	1
Bevel Pinion Rear	HM 903244/HM 903216	1
Bevel Pinion Pilot	F 19040	1
Bevel Pinion Front	44143/44348	1

FDRK 4300 OB		
Differential Left	3994/JM 511910	1
Differential Right	3994/JM 511910	1
Bevel Pinion Rear	HM 803146/HM 803110	1
Bevel Pinion Pilot	F 19040	1
Bevel Pinion Front	44143/44348	1

FDRK 4310 OB		
Differential Left	3994/JM 511910	1
Differential Right	3994/JM 511910	1
Bevel Pinion Rear	HM 903249 A/HM 903216	1
Bevel Pinion Pilot	*	1
Bevel Pinion Front	HM 903249 A/HM 903216	1

FDRK 4315 OB		
Differential Left	3994/JM 511910	1
Differential Right	3994/JM 511910	1
Bevel Pinion Rear	HM 803149/HM 803110	1
Bevel Pinion Pilot	*	1
Bevel Pinion Front	HM 803149/HM 803110	1

FDRK 4325 OB		
Differential Left	47490/47420	1
Differential Right	33275/33472	1
Bevel Pinion Rear	HM 807044/HM 807010	1
Bevel Pinion Pilot	F 19035	1
Bevel Pinion Front	M 804049/M 804010	1

FDRK 4330 OB		
Differential Left	JLM 714149/JLM 714110	1
Differential Right	JLM 714149/JLM 714110	1
Bevel Pinion Rear	55200 C/55437	1
Bevel Pinion Pilot	F 19035	1
Bevel Pinion Front	HM 804846/HM 804810	1

FDRK 4345 OB		
Differential Left	JM 716649/JM 716610	1
Differential Right	JP 10049/JP 10010 A	1
Bevel Pinion Rear	55200 C/55437	1
Bevel Pinion Pilot	F 19035	1
Bevel Pinion Front	M 804049/M 804010	1

POSITION	FERSA	QTY
FDRK 4350 OB		
Differential Left	JM 716649/JM 716610	1
Differential Right	JM 716649/JM 716610	1
Bevel Pinion Rear	55200 C/55437	1
Bevel Pinion Pilot	F 19035	1
Bevel Pinion Front	M 804049/M 804010	1

FDRK 4355 OB		
Differential Left	JM 716649/JM 716610	1
Differential Right	JM 716649/JM 716610	1
Input Shaft Front	JM 511946/JM 511910	1
Input Shaft Rear	JLM 710949 C/JLM 710910	1
Output Shaft	LM 603049/LM 603011	2
Bevel Pinion Rear	H 715334/H 715311	1
Bevel Pinion Front	72212 C/72487	1

FDRK 4356 OB		
Differential Left	JM 716649/JM 716610	1
Differential Right	JM 716649/JM 716610	1
Input Shaft Front	JM 511945/JM 511910	1
Input Shaft Rear	JLM 710949 C/JLM 710910	1
Output Shaft	LM 603049/LM 603011	2
Bevel Pinion Rear	H 715334/H 715311	1
Bevel Pinion Front	72212 C/72487	1

FDRK 4360 OB		
Differential Left	JP 10049/JP 10010 A	1
Differential Right	JLM 714149/JLM 714110	1
Bevel Pinion Rear	55200 C/55437	1
Bevel Pinion Pilot	*	1
Bevel Pinion Front	M 804049/M 804010	1

FDRK 4375 OB		
Differential Left	JP 12049/JP 12010	1
Differential Right	JM 716649/JM 716610	1
Bevel Pinion Rear	78225 C/78551	1
Bevel Pinion Pilot	F 19100	1
Bevel Pinion Front	55206 C/55437	1

FDRK 4390 OB		
Differential Left	JP 10049/JP 10010 A	1
Differential Right	JM 716649/JM 716610	1
Bevel Pinion Rear	72212 C/72487	1
Bevel Pinion Pilot	F 19035	1
Bevel Pinion Front	55206 C/55437	1

FDRK 4395 OB		
Differential Left	JM 716649/JM 716610	1
Differential Right	JM 716649/JM 716610	1
Input Shaft Front	JM 511946/3920	1
Input Shaft Rear	JLM 710949 C/JLM 710910	1
Output Shaft	LM 104949/JLM 104910	2
Bevel Pinion Rear	H 715334/H 715311	1
Bevel Pinion Front	72212 C/72487	1

1.2\ F-Box Differential Rebuild Kit

POSITION	FERSA	QTY
FDRK 4396 OB		
Differential Left	JM 716649/JM 716610	1
Differential Right	JM 716649/JM 716610	1
Input Shaft Front	JM 511945/3920	1
Input Shaft Rear	JLM 710949 C/JLM 710910	1
Output Shaft	LM 104949/JLM 104910	2
Bevel Pinion Rear	H 715334/H 715311	1
Bevel Pinion Front	72212 C/72487	1

FDRK 4405 OB		
Differential Left	JP 10049/JP 10010 A	1
Differential Right	JM 716649/JM 716610	1
Input Shaft Front	JM 511946/JM 511910	1
Input Shaft Front Cup - New	CUP 3920	1
Input Shaft Rear	JLM 710949 C/JLM 710910	1
Output Shaft	LM 104949/JLM 104910	2
Bevel Pinion Rear	H 715334/H 715311	1
Bevel Pinion Front	72212 C/72487	1

FDRK 4406 OB		
Differential Left	JP 10049/JP 10010 A	1
Differential Right	JM 716649/JM 716610	1
Input Shaft Front	JM 511945/3920	1
Input Shaft Rear	JLM 710949 C/JLM 710910	1
Output Shaft	LM 104949/JLM 104910	2
Bevel Pinion Rear	H 715334/H 715311	1
Bevel Pinion Front	72212 C/72487	1

FDRK 4415 OB		
Differential Left	32021 XF	1
Differential Right	32021 XF	1
Bevel Pinion Rear	9278/9220	1
Bevel Pinion Pilot	*	1
Bevel Pinion Front	HM 813843/HM 813810	1

FDRK 4420 OB		
Differential Left	32021 XF	1
Differential Right	32021 XF	1
Input Shaft Front	HM 813843/HM 813810	1
Input Shaft Rear	JLM 714149/JLM 714110	1
Bevel Pinion Rear	H 715343/H 715311	1
Bevel Pinion Front	65237/65500	1

FDRK 4422 OB		
Differential Left	594 A/592 A	1
Differential Right	594 A/592 A	1
Input Shaft Front	HM 813843/HM 813810	1
Input Shaft Rear	JLM 714149/JLM 714110	1
Bevel Pinion Rear	H 715343/H 715311	1
Bevel Pinion Front	65237/65500	1

POSITION	FERSA	QTY
FDRK 4423 OB		
Differential Left	52400/52618	1
Differential Right	594 A/592 A	1
Input Shaft Front	HM 813843/HM 813810	1
Input Shaft Rear	JLM 714149/JLM 714110	1
Bevel Pinion Rear	H 715343/H 715311	1
Bevel Pinion Front	65237/65500	1

FDRK 4426 OB		
Differential Left	594 A/592 A	1
Differential Right	594 A/592 A	1
Bevel Pinion Rear	9278/9220	1
Bevel Pinion Pilot	F 19033	1
Bevel Pinion Front	HM 813843/HM 813810	1

FDRK 4428 OB		
Differential Left	52400/52618	1
Differential Right	594 A/592 A	1
Bevel Pinion Rear	9278/9220	1
Bevel Pinion Pilot	F 19033	1
Bevel Pinion Front	HM 813843/HM 813810	1

FDRK 4435 OB		
Differential Left	JHM 720249/JHM 720210	1
Differential Right	64450/64700	1
Bevel Pinion Rear	9278/9220	1
Bevel Pinion Pilot	F 19063	1
Bevel Pinion Front	H 715334/H 715311	1

FDRK 4436 OB		
Differential Left	JHM 720249/JHM 720210	1
Differential Right	64450/64700	1
Bevel Pinion Rear	9278/9220	1
Bevel Pinion Pilot	*	1
Bevel Pinion Front	H 715334/H 715311	1

FDRK 4437 OB		
Differential Left	*	1
Differential Right	JM 822049/JM 822010	1
Bevel Pinion Rear	9278/9220	1
Bevel Pinion Pilot	F 19063	1
Bevel Pinion Front	H 715334/H 715311	1

FDRK 4438 OB		
Differential Left	*	1
Differential Right	JM 822049/JM 822010	1
Bevel Pinion Rear	9278/9220	1
Bevel Pinion Pilot	*	1
Bevel Pinion Front	H 715334/H 715311	1

POSITION	FERSA	QTY
FDRK 4440 OB		
Differential Left	52387/52618	1
Differential Right	*	1
Input Shaft	HM 813844/HM 813810	1
Oil Pump Idler Gear	*	1
Output Shaft	385 A/382 A	2
Bevel Pinion Rear	78250 AC/78551	1
Bevel Pinion Pilot	*	1
Bevel Pinion Pilot	*	1
Bevel Pinion Front	78250 AC/78551	1
Rear Side Gear	JM 515649/JM 515610	1

FDRK 4441 OB		
Differential Left	52387/52618	1
Differential Right	*	1
Input Shaft	HM 813844/HM 813810	1
Oil Pump Idler Gear	*	1
Output Shaft	385 A/382 A	2
Bevel Pinion Rear	78250 AC/78551	1
Bevel Pinion Pilot	F 19063	1
Bevel Pinion Front	78250 AC/78551	1
Rear Side Gear	JM 515649/JM 515610	1

FDRK 4442 OB		
Differential Left	52387/52618	1
Differential Right	*	1
Input Shaft	HM 813844/HM 813810	1
Oil Pump Idler Gear	*	1
Output Shaft	385 A/382 A	2
Bevel Pinion Rear	78250 AC/78551	1
Bevel Pinion Pilot	*	1
Bevel Pinion Front	78250 AC/78551	1
Rear Side Gear	JM 515649/JM 515610	1

FDRK 4443 OB		
Differential Left	52387/52618	1
Differential Right	*	1
Input Shaft Front	496/493	1
Input Shaft Rear	29685/29620	1
Bevel Pinion Rear	78250 AC/78551	1
Bevel Pinion Pilot	F 19063	1
Bevel Pinion Front	78250 AC/78551	1

FDRK 4444 OB		
Differential Left	52387/52618	1
Differential Right	*	1
Input Shaft Front	496/493	1
Input Shaft Rear	29685/29620	1
Bevel Pinion Rear	78250 AC/78551	1
Bevel Pinion Pilot	*	1
Bevel Pinion Front	78250 AC/78551	1

POSITION	FERSA	QTY
FDRK 4450 OB		
Differential Left	52387/52618	1
Differential Right	*	1
Input Shaft Front	496/493	1
Input Shaft Rear	29685/29620	1
Bevel Pinion Rear	78250 AC/78551	1
Bevel Pinion Pilot	*	1
Bevel Pinion Pilot	*	1
Bevel Pinion Front	78250 AC/78551	1

FDRK 4461 OB		
Differential Left	JM 716649/JM 716610	1
Differential Right	JM 716649/JM 716610	1
Bevel Pinion Rear	H 715334/H 715311	1
Bevel Pinion Front	72225 C/72487	1

FDRK 4753 OB		
Differential Left	28682/28622	1
Differential Right	28682/28622	1
Bevel Pinion Rear	HM 803149/HM 803110	1
Bevel Pinion Front	M 86649/M 86610	1

FDRK 4841 OB		
Differential Left	594 A/592 A	1
Differential Right	594 A/592 A	1
Helical Gear Needle	*	2
Helical Gear Thrust	*	1
Input Shaft Front	JM 511945/3920	1
Input Shaft Rear	JLM 714149/JLM 714110	1
Bevel Pinion Rear	H 715334/H 715311	1
Bevel Pinion Front	72212 C/72487	1

FDRK 4842 OB		
Differential Left	594 A/592 A	1
Differential Right	594 A/592 A	1
Bevel Pinion Rear	H 715334/H 715311	1
Bevel Pinion Front	72212 C/72487	1

FDRK 4843 OB		
Differential Left	*	1
Differential Right	*	1
Bevel Pinion Rear	72212 C/72487	1
Bevel Pinion Pilot	F 19035	1
Bevel Pinion Front	55206 C/55437	1

FDRK 4844 OB		
Differential Left	*	1
Differential Right	*	1
Bevel Pinion Rear	72212 C/72487	1
Bevel Pinion Pilot	F 19035	1
Bevel Pinion Front	55206 C/55437	1

2\

2.1 HEAVY DUTY TRANSMISSION INDEX

BRAND	Pg.
CLARK	78
EATON/FULLER	79
GMC	90
INTERNATIONAL HARVESTER/NAVISTAR	90
MACK	90
MERITOR/ROCKWELL	90
NEW PROCESS TRANSMISSIONS	90
SPICER/TTC TRANSMISSIONS	91
VOLVO	93
WARNER	93

2.2 F-BOX TRANSMISSION REBUILD KIT

	Pg.
	94

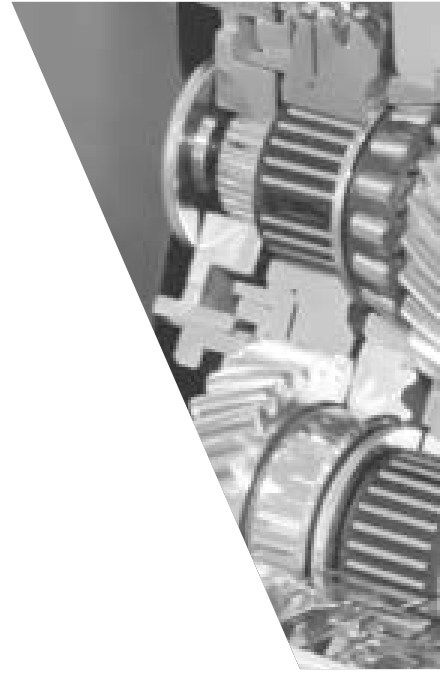

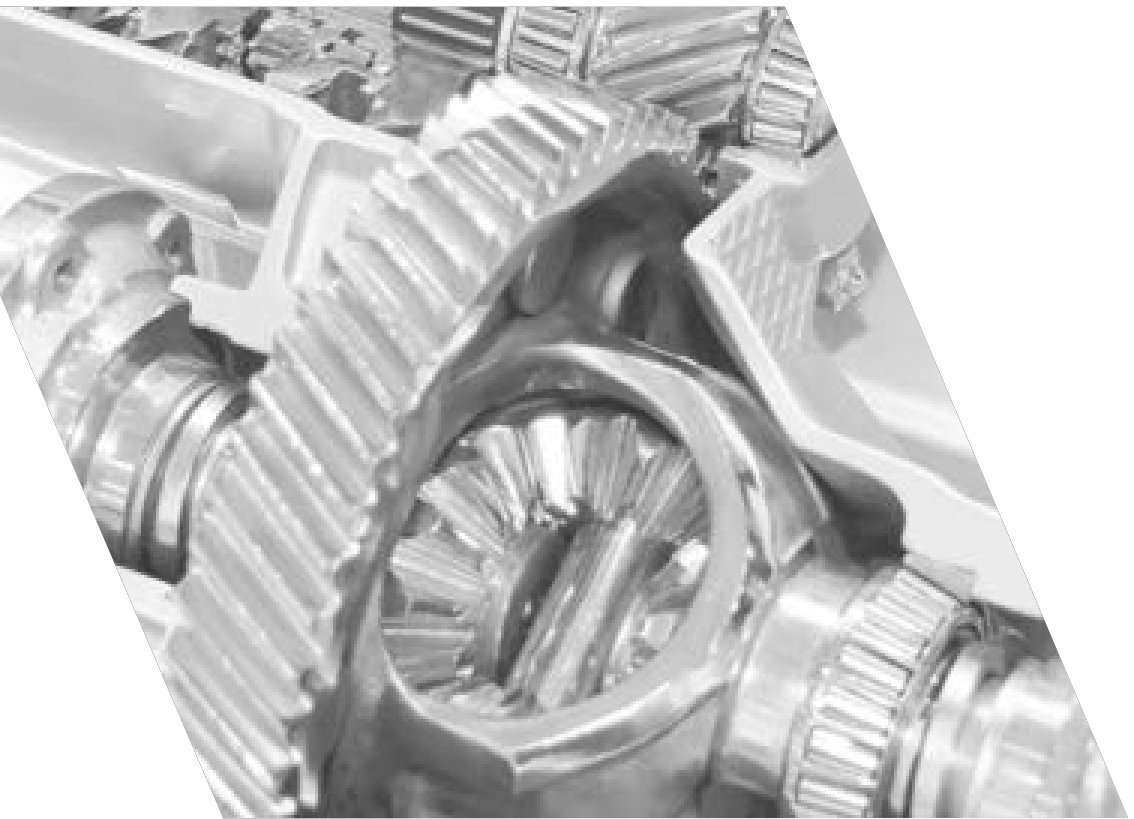
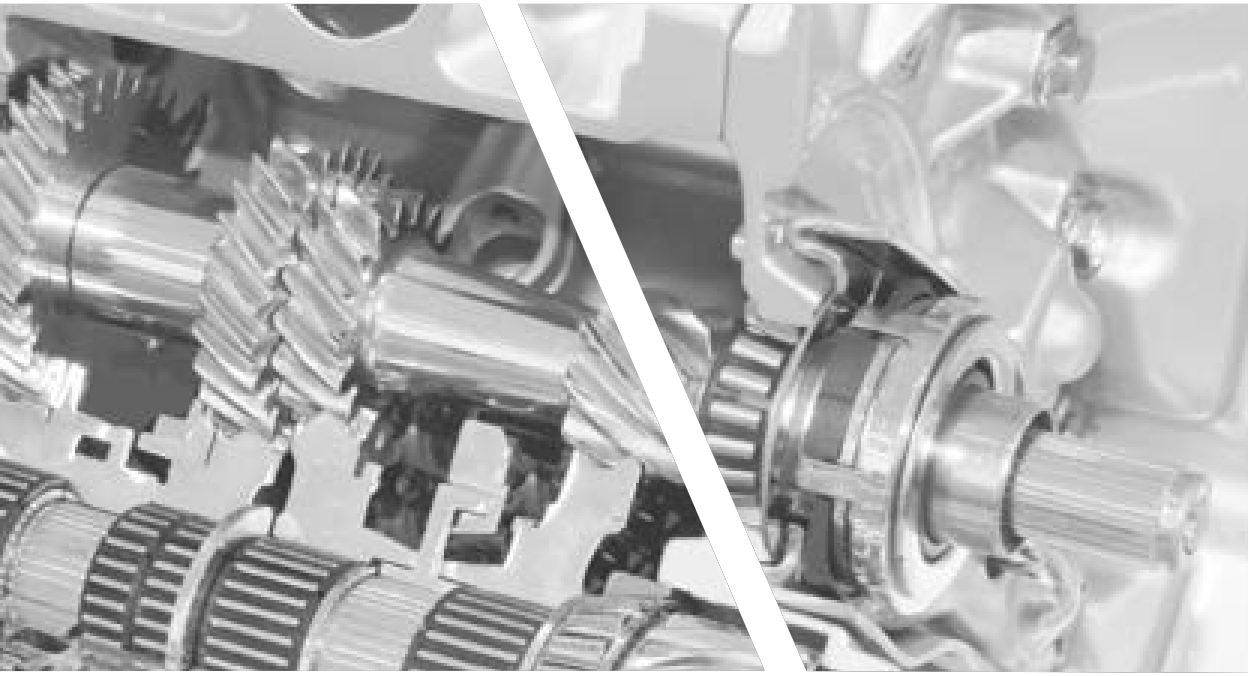

2.1 \ Heavy Duty Transmission Index

Model n°	Comments	Fersa Bearing Kit	Pg.
CLARK			
Clark 5 Speed Models			
250-V	1959 & Later	FTRK 23 OB	94
250-V18		FTRK 23B OB	94
250-VO	1959 & Later	FTRK 23 OB	94
251-V	1959 & Later	FTRK 23 OB	94
251-VO	1959 & Later	FTRK 23 OB	94
251-VO18		FTRK 23B OB	94
259-V		FTRK 23B OB	94
264-V	1959 & Later	FTRK 23 OB	94
264-VO	1959 & Later	FTRK 23 OB	94
264-VO48		FTRK 23 OB	94
264-VO49		FTRK 23 OB	94
265-V	1959 & Later	FTRK 23 OB	94
265-VO	1959 & Later	FTRK 23 OB	94
267-V	1959 & Later	FTRK 23 OB	94
267-VO	1959 & Later	FTRK 23 OB	94
268-V	1959 & Later	FTRK 23 OB	94
269-V	1959 & Later w/ Narrow Output Shaft	FTRK 23B OB	94
	1959 & Later w/o Narrow Output Shaft	FTRK 23 OB	94
269-V35	1959 & Later	FTRK 23 OB	94
280-V	1959 & Later	FTRK 148 OB	97
280-VHD	1959 & Later	FTRK 190 OB	100
280-VO	1959 & Later	FTRK 148 OB	97
280-VO18	1959 & Later	FTRK 148 OB	97
280-VO3	1959 & Later	FTRK 148 OB	97
280-VO4	1959 & Later	FTRK 148 OB	97
282-V		FTRK 148 OB	97
282-V11		FTRK 148 OB	97
282-V55		FTRK 148 OB	97
282-VHD		FTRK 190 OB	100
282-VHD12		FTRK 190 OB	100
282-VHD13		FTRK 190 OB	100
282-VHD2		FTRK 190 OB	100
285-V		FTRK 148 OB	97
285-V54		FTRK 148 OB	97
285-V9		FTRK 148 OB	97
285-VHD		FTRK 190 OB	100
285-VHD13		FTRK 190 OB	100
285-VHD2		FTRK 190 OB	100
305-V		FTRK 48 OB	95
307-V		FTRK 48 OB	95
315-V		FTRK 48 OB	95
318-V		FTRK 48 OB	95
320-V		FTRK 132 OB	97
325-V		FTRK 132 OB	97
327-V		FTRK 132 OB	97
328-V		FTRK 132 OB	97
380-V		FTRK 133 OB	97
380-VO		FTRK 133 OB	97
381-V		FTRK 133 OB	97
385-V		FTRK 133 OB	97

Model n°	Comments	Fersa Bearing Kit	Pg.
387-V		FTRK 133 OB	97
388-V		FTRK 133 OB	97
390-V	1-1/2" Input Shaft & 2" Output Shaft	FTRK 390F OB	104
	1-3/4" Input Shaft & 2" Output Shaft	FTRK 390G OB	104
	1-1/2" Input Shaft & 1-3/4" Output Shaft	FTRK 390H OB	104
397-V	1-1/2" Input Shaft & 2" Output Shaft	FTRK 390F OB	104
	1-3/4" Input Shaft & 2" Output Shaft	FTRK 390G OB	104
	1-1/2" Input Shaft & 1-3/4" Output Shaft	FTRK 390H OB	104
2621-V	w/ Narrow Output Shaft w/o Narrow Output Shaft	FTRK 23B OB FTRK 23 OB	94 94
2621-V1	w/ Narrow Output Shaft w/o Narrow Output Shaft	FTRK 23B OB FTRK 23 OB	94 94
2622-V12		FTRK 23B OB	94
2622-V7		FTRK 23B OB	94
2651-V	w/ Narrow Output Shaft w/o Narrow Output Shaft	FTRK 23B OB FTRK 23 OB	94 94
2651-V1	w/ Narrow Output Shaft w/o Narrow Output Shaft	FTRK 23B OB FTRK 23 OB	94 94
2653-V		FTRK 23B OB	94
2653-V10		FTRK 23B OB	94
2653-V5		FTRK 23B OB	94
2653-V9		FTRK 23B OB	94
2653-VO		FTRK 23B OB	94
CL450	1-1/4" or 1-1/2" Input Shaft	FTRK 208 OB	102
	1-3/4" Input Shaft	FTRK 208D OB	102
CL455	1-1/4" or 1-1/2" Input Shaft	FTRK 208 OB	102
	1-3/4" Input Shaft	FTRK 208D OB	102
CL457	1-1/4" or 1-1/2" Input Shaft	FTRK 208 OB	102
	1-3/4" Input Shaft	FTRK 208D OB	102
CL550	1-1/2" Input Shaft & 2" Output Shaft	FTRK 390F OB	104
	1-3/4" Input Shaft & 2" Output Shaft	FTRK 390G OB	104
	1-1/2" Input Shaft & 1-3/4" Output Shaft	FTRK 390H OB	104
CL551	1-1/2" Input Shaft & 2" Output Shaft	FTRK 390F OB	104
	1-3/4" Input Shaft & 2" Output Shaft	FTRK 390G OB	104
	1-1/2" Input Shaft & 1-3/4" Output Shaft	FTRK 390H OB	104
CL557	1-1/2" Input Shaft & 2" Output Shaft	FTRK 390F OB	104
	1-3/4" Input Shaft & 2" Output Shaft	FTRK 390G OB	104
	1-1/2" Input Shaft & 1-3/4" Output Shaft	FTRK 390H OB	104

Model n°	Comments	Fersa Bearing Kit	Pg.
----------	----------	-------------------	-----

CLARK

Clark 5 Speed Models

CL558	1-1/2" Input Shaft & 2" Output Shaft	FTRK 390F OB	104
	1-3/4" Input Shaft & 2" Output Shaft	FTRK 390G OB	104
	1-1/2" Input Shaft & 1-3/4" Output Shaft	FTRK 390H OB	104

EATON/FULLER

2 Speed Auxiliary Models

2-A-92		FTRK 400 OB	104
AT-1202		FTRK 401 OB	104

5 Speed Auxiliary Models

F-5405B-DM3		FTRK 3440 OB	122
F-5505B-DM3		FTRK 3440 OB	122
F-6405B-DM3		FTRK 3440 OB	122
F-6505B-DM3		FTRK 3440 OB	122
FS-4005A	w/ 1.375" or 1.5" I/S	FTRK 208 OB	102
	w/ 1.75" I/S	FTRK 208D OB	102
FS-4005B	w/ 1.375" or 1.5" I/S	FTRK 208 OB	102
	w/ 1.75" I/S	FTRK 208D OB	102
FS-4005C	w/ 1.375" or 1.5" I/S	FTRK 208 OB	102
	w/ 1.75" I/S	FTRK 208D OB	102
FS-4205A	w/ 1.5" I/S & 2" O/S	FTRK 7000 OB	127
	w/ 1.75" I/S	FTRK 7013 OB	127
FS-4205B	w/ 1.5" I/S & 2" O/S	FTRK 7000 OB	127
	w/ 1.75" I/S	FTRK 7013 OB	127
FS-4205C	w/ 1.5" I/S & 2" O/S	FTRK 7000 OB	127
	w/ 1.75" I/S	FTRK 7013 OB	127
FS-5005A	w/ 1.5" I/S & 2" O/S	FTRK 395F OB	104
	w/ 1.5" I/S & 1.75" O/S	FTRK 395G OB	104
	w/ 1.75" I/S & 2" O/S	FTRK 395H OB	104
FS-5005B	w/ 1.5" I/S & 2" O/S	FTRK 395F OB	104
	w/ 1.5" I/S & 1.75" O/S	FTRK 395G OB	104
	w/ 1.75" I/S & 2" O/S	FTRK 395H OB	104
FS-5005C	w/ 1.5" I/S & 2" O/S	FTRK 395F OB	104
	w/ 1.5" I/S & 1.75" O/S	FTRK 395G OB	104
	w/ 1.75" I/S & 2" O/S	FTRK 395H OB	104
FS-5205A	w/ 1.5" I/S	FTRK 7032 OB	127
	w/ 1.75" I/S	FTRK 7033 OB	127
FS-5205B	w/ 1.5" I/S	FTRK 7032 OB	127
	w/ 1.75" I/S	FTRK 7033 OB	127
FS-5205C	w/ 1.5" I/S	FTRK 7032 OB	127
	w/ 1.75" I/S	FTRK 7033 OB	127
FS-6205A		FTRK 7035 OB	127
FS-6205B		FTRK 7035 OB	127
FS-6305A		FTRK 7035 OB	127
FS-6305B		FTRK 7035 OB	127
T-11605A	w/ 2" Pull Type I/S	FTRK 58A OB	95

Model n°	Comments	Fersa Bearing Kit	Pg.
----------	----------	-------------------	-----

T-11605B	w/ 2" Pull Type I/S	FTRK 58A OB	95
T-11605C	w/ 2" Pull Type I/S	FTRK 58A OB	95
T-11605D	w/ 2" Pull Type I/S	FTRK 58A OB	95
T-11605F	w/ 2" Pull Type I/S	FTRK 58A OB	95
T-11605M	w/ 2" Pull Type I/S	FTRK 58A OB	95
T-905		FTRK 58 OB	95
T-955		FTRK 1000 OB	107
T-955LL		FTRK 1000 OB	108
TO-11605A	w/ 2" Pull Type I/S	FTRK 58A OB	95
TO-11605B	w/ 2" Pull Type I/S	FTRK 58A OB	95
TO-11605C	w/ 2" Pull Type I/S	FTRK 58A OB	95
TO-11605D	w/ 2" Pull Type I/S	FTRK 58A OB	95

6 Speed Models

FO-5406B-DM3		FTRK 3440 OB	122
FO-5506B-DM3		FTRK 3440 OB	122
FO-6406A-ASX		FTRK 3440 OB	122
FO-6406B-DM3		FTRK 3440 OB	122
FO-6506B-DMW		FTRK 3440 OB	122
FO-8406A-ASX		FTRK 3440 OB	122
FS-5106A		FTRK 2041 OB	112
FS-5306A		FTRK 7052 OB	127
FS-5406A		FTRK 3423 OB	122
FS-5406N		FTRK 3423 OB	122
FS-6206A		FTRK 2041 OB	112
FS-6306A		FTRK 7052 OB	127
FS-6406A		FTRK 3423 OB	122
FS-6406N		FTRK 3423 OB	122
FS-7206		FTRK 2130 OB	114
FS-8206A		FTRK 2490 OB	116
FSB-5406B		FTRK 3423 OB	122
FSO-6406A		FTRK 3423 OB	122
FSO-8206		FTRK 2464 OB	116
FSO-8406A		FTRK 3423 OB	122
RT-906		FTRK 1000 OB	107

7 Speed Models

RTO-1157DL		FTRK 188 OB	100
RTO-1157DLL		FTRK 184 OB	100
RTO-11607L		FTRK 201 OB	101
RTO-11607LL		FTRK 1867 OB	110
RTO-11707DLL		FTRK 2045 OB	112
RTO-11707LL		FTRK 2045 OB	112
RTO-13707DLL		FTRK 2855 OB	118
RTO-13707MLL		FTRK 2855 OB	118
RTOF-11607L		FTRK 201 OB	101

2.1 \ Heavy Duty Transmission Index

Model n°	Comments	Fersa Bearing Kit	Pg.
EATON/FULLER			
7 Speed Models			
RTOF-11607LL		FTRK 1867 OB	110
RTOF-11707LL		FTRK 2045 OB	112
RTOF-13707DLL		FTRK 2855 OB	118
RTOF-13707MLL		FTRK 2855 OB	118
T-11607A		FTRK 2771 OB	117
T-11607B		FTRK 2771 OB	117
T-14607A		FTRK 2771 OB	117
T-14607B		FTRK 2771 OB	117
T-8607A		FTRK 1877 OB	110
T-8607B		FTRK 1877 OB	110
TX-14607B		FTRK 2771 OB	117
TX-8607B		FTRK 1877 OB	110

8 Speed Models			
FO-10E308LL-VCS		FTRK 3942 OB	126
FO-11E308LL-VCS		FTRK 3942 OB	126
FO-12E308LL-VCS		FTRK 3942 OB	126
FO-14E308LL-VCS		FTRK 3942 OB	126
FO-16E308LL-VCS		FTRK 3942 OB	126
FO-17E308LL-VCS		FTRK 3942 OB	126
RT-11608	w/ 1.75" Push Type I/S w/ 2" Pull Type I/S	FTRK 202 OB	101
		FTRK 202 OB	101
RT-7608LL		FTRK 2047 OB	112
RT-8608L	w/ 1.75" Push Type I/S w/ 2" Pull Type I/S	FTRK 202 OB	101
		FTRK 202 OB	101
RT-8908LL		FTRK 3273 OB	119
RT-9508		FTRK 1000 OB	107
RTF-11608	w/ 1.75" Push Type I/S w/ 2" Pull Type I/S	FTRK 202 OB	101
		FTRK 202 OB	101
RTF-8608L	w/ 1.75" Push Type I/S w/ 2" Pull Type I/S	FTRK 202 OB	101
		FTRK 202 OB	101
RTF-8908LL		FTRK 3273 OB	120
RTO-11608L	w/ 1.75" Push Type I/S w/ 2" Pull Type I/S	FTRK 203 OB	101
		FTRK 203 OB	101
RTO-11708LL		FTRK 3660 OB	125
RTO-11908LL		FTRK 3256 OB	119
RTO-14608LL		FTRK 207 OB	102
RTO-14708LL		FTRK 2043 OB	112
RTO-14908LL	w/ 85mm Aux Drive Gear w/ 90mm Aux Drive Gear	FTRK 3233 OB	119
		FTRK 3256 OB	119
RTO-16908LL		FTRK 3233 OB	119
RTO-9508		FTRK 1000 OB	107

Model n°	Comments	Fersa Bearing Kit	Pg.
RTOF-11608LL	w/ 1.75" Push Type I/S	FTRK 203 OB	101
RTOF-11608LL	w/ 2" Pull Type I/S	FTRK 203 OB	101
RTOF-11708LL		FTRK 3660 OB	125
RTOF-11908LL		FTRK 3256 OB	119
RTOF-14608LL		FTRK 207 OB	102
RTOF-14708LL		FTRK 2043 OB	112
RTOF-14908LL	w/ 85mm Aux Drive Gear w/ 90mm Aux Drive Gear	FTRK 3233 OB	119
		FTRK 3256 OB	119
RTOF-16908LL		FTRK 3233 OB	119
RTX-11608LL	w/ 1.75" Push Type I/S w/ 2" Pull Type I/S	FTRK 203 OB	101
		FTRK 203 OB	101
RTX-11708LL		FTRK 3660 OB	125
RTX-14608LL		FTRK 207 OB	102
RTX-14708LL		FTRK 2043 OB	112
RTXF-11608LL	w/ 1.75" Push Type I/S w/ 2" Pull Type I/S	FTRK 203 OB	101
		FTRK 203 OB	101
RTXF-11708LL		FTRK 3660 OB	125
RTXF-14608LL		FTRK 207 OB	102
RTXF-14708LL		FTRK 2043 OB	112

9 Speed Models			
FO-10E309ALL-VMW		FTRK 3942 OB	126
FO-11309ALL-VMS		FTRK 3942 OB	126
FO-12E309ALL-VMS		FTRK 3942 OB	126
FO-14E309ALL-VMS		FTRK 3942 OB	126
FO-16E309ALL-VMS		FTRK 3942 OB	126
FO-17E309ALL-VMS		FTRK 3942 OB	126
RT-11509		FTRK 1858 OB	109
RT-11609A	w/ 1.75" Push Type I/S w/ 2" Pull Type I/S	FTRK 202 OB	101
		FTRK 202 OB	101
RT-11709A		FTRK 2049 OB	113
RT-11709H		FTRK 2049 OB	113
RT-12509		FTRK 160 OB	99
RT-12609A	w/ 1.75" Push Type I/S w/ 2" Pull Type I/S	FTRK 202 OB	101
		FTRK 202 OB	101
RT-12709A		FTRK 2049 OB	113

Model n°	Comments	Fersa Bearing Kit	Pg.
EATON/FULLER			
9 Speed Models			
RT-12709H		FTRK 2049 OB	113
RT-13609A		FTRK 2282 OB	114
RT-13709H		FTRK 2284 OB	115
RT-14609A		FTRK 205 OB	101
RT-14709A		FTRK 2275 OB	114
RT-14709H		FTRK 2275 OB	114
RT-6609		FTRK 2048 OB	112
RT-8609		FTRK 1876 OB	110
RT-8709B		FTRK 3322 OB	120
RTF-11509		FTRK 1858 OB	109
RTF-11609A	w/ 1.75" Push Type I/S	FTRK 202 OB	101
RTF-11609A	w/ 2" Pull Type I/S	FTRK 202 OB	101
RTF-11709H		FTRK 2049 OB	113
RTF-12509		FTRK 160 OB	99
RTF-12609A	w/ 1.75" Push Type I/S	FTRK 202 OB	101
	w/ 2" Pull Type I/S	FTRK 202 OB	101
RTF-12709H		FTRK 2049 OB	113
RTF-13609A		FTRK 2282 OB	114
RTF-13709H		FTRK 2284 OB	115
RTF-14609A		FTRK 205 OB	101
RTF-14709H		FTRK 2275 OB	114
RTF-8709B		FTRK 3322 OB	120
RTL-16609E		FTRK 3586 OB	124
RTLFC-16609E		FTRK 3586 OB	124
RTL-16609E		FTRK 3586 OB	124
RTLOC-16909A-T2		FTRK 3598 OB	124
RTLOCFC-16909A-T2		FTRK 3598 OB	124
RTO-11509		FTRK 1858 OB	109
RTO-11609A	w/ 1.75" Push Type I/S	FTRK 202 OB	101
	w/ 2" Pull Type I/S	FTRK 202 OB	101
RTO-11609B	w/ 1.75" Push Type I/S	FTRK 202 OB	101
	w/ 2" Pull Type I/S	FTRK 202 OB	101
RTO-11709A		FTRK 2284 OB	115
RTO-11709B		FTRK 2284 OB	115
RTO-11709MLL		FTRK 2847 OB	118
RTO-11909ALL		FTRK 3283 OB	120
RTO-11909MLL		FTRK 3283 OB	120
RTO-12509		FTRK 160 OB	99
RTO-12609A	w/ 1.75" Push Type I/S	FTRK 202 OB	101
	w/ 2" Pull Type I/S	FTRK 202 OB	101
RTO-12609B	w/ 1.75" Push Type I/S	FTRK 202 OB	101
	w/ 2" Pull Type I/S	FTRK 202 OB	101
RTO-12709A		FTRK 2284 OB	115
RTO-12709B		FTRK 2284 OB	115
RTO-14609A		FTRK 205 OB	101
RTO-14609B		FTRK 205 OB	101
RTO-14709A		FTRK 2275 OB	114
RTO-14709B		FTRK 2275 OB	114

Model n°	Comments	Fersa Bearing Kit	Pg.
RTO-14709H		FTRK 2275 OB	114
RTO-14709MLL		FTRK 2847 OB	118
RTO-14909ALL	w/ 90mm Aux Drive Gear	FTRK 3283 OB	120
	w/ 85mm Aux Drive Gear	FTRK 3413 OB	121
RTO-14909MLL		FTRK 3283 OB	120
RTO-16909ALL		FTRK 3413 OB	121
RTO-909		FTRK 1000 OB	107
RTO-9509		FTRK 1000 OB	107
RTOC-16709A		FTRK 3596 OB	124
RTOC-16909A		FTRK 3598 OB	124
RTOC-18909A		FTRK 4057 OB	126
RTOCF-16709A		FTRK 3596 OB	124
RTOF-11509		FTRK 1858 OB	109
RTOF-11609A	w/ 1.75" Push Type I/S	FTRK 202 OB	101
	w/ 2" Pull Type I/S	FTRK 202 OB	101
RTOF-11609B	w/ 1.75" Push Type I/S	FTRK 202 OB	101
	w/ 2" Pull Type I/S	FTRK 202 OB	101
RTOF-11709MLL		FTRK 2847 OB	118
RTOF-11909ALL		FTRK 3283 OB	120
RTOF-11909MLL		FTRK 3283 OB	120
RTOF-12509		FTRK 160 OB	99
RTOF-12609A	w/ 1.75" Push Type I/S	FTRK 202 OB	101
	w/ 2" Pull Type I/S	FTRK 202 OB	101
RTOF-12609B	w/ 1.75" Push Type I/S	FTRK 202 OB	101
	w/ 2" Pull Type I/S	FTRK 202 OB	101
RTOF-14609A		FTRK 205 OB	101
RTOF-14609B		FTRK 205 OB	101
RTOF-14709MLL		FTRK 2847 OB	118
RTOF-14909ALL	w/ 90mm Aux Drive Gear	FTRK 3283 OB	120
RTOF-14909ALL	w/ 85mm Aux Drive Gear	FTRK 3413 OB	121
RTOF-14909MLL		FTRK 3283 OB	120
RTOF-16909ALL		FTRK 3413 OB	121
RTOFC-16909A		FTRK 3598 OB	124
RTX-11509		FTRK 1858 OB	109
RTX-11609A	w/ 1.75" Push Type I/S	FTRK 202 OB	101
RTX-11609A	w/ 2" Pull Type I/S	FTRK 202 OB	101
RTX-11609B	w/ 1.75" Push Type I/S	FTRK 202 OB	101
	w/ 2" Pull Type I/S	FTRK 202 OB	101
RTX-11609P	w/ 1.75" Push Type I/S	FTRK 202 OB	101
	w/ 2" Pull Type I/S	FTRK 202 OB	101

2.1 \ Heavy Duty Transmission Index

Model n°	Comments	Fersa Bearing Kit	Pg.
EATON/FULLER			
9 Speed Models			
RTX-11609R	w/ 1.75" Push Type I/S w/ 2" Pull Type I/S	FTRK 202 OB FTRK 202 OB	101 101
RTX-11709A		FTRK 2284 OB	115
RTX-11709B		FTRK 2284 OB	115
RTX-11709H		FTRK 2284 OB	115
RTX-12509		FTRK 160 OB	99
RTX-12609A	w/ 1.75" Push Type I/S w/ 2" Pull Type I/S	FTRK 202 OB FTRK 202 OB	101 101
RTX-12609B	w/ 1.75" Push Type I/S w/ 2" Pull Type I/S	FTRK 202 OB FTRK 202 OB	101 101
RTX-12609P	w/ 1.75" Push Type I/S w/ 2" Pull Type I/S	FTRK 202 OB FTRK 202 OB	101 101
RTX-12609R	w/ 1.75" Push Type I/S w/ 2" Pull Type I/S	FTRK 202 OB FTRK 202 OB	101 101
RTX-12709A		FTRK 2284 OB	115
RTX-12709B		FTRK 2284 OB	115
RTX-12709H		FTRK 2284 OB	115
RTX-13609A		FTRK 2282 OB	114
RTX-13609B		FTRK 2282 OB	114
RTX-13609P		FTRK 2282 OB	114
RTX-13609R		FTRK 2282 OB	114
RTX-13709H		FTRK 2284 OB	115
RTX-14609A		FTRK 205 OB	101
RTX-14609B		FTRK 205 OB	101
RTX-14609P		FTRK 205 OB	101
RTX-14609R		FTRK 205 OB	101
RTX-16709B		FTRK 2275 OB	114
RTX-16709H		FTRK 2275 OB	114
RTXF-11509		FTRK 1858 OB	109
RTXF-11609A	w/ 1.75" Push Type I/S w/ 2" Pull Type I/S	FTRK 202 OB FTRK 202 OB	101 101
RTXF-11609B	w/ 1.75" Push Type I/S w/ 2" Pull Type I/S	FTRK 202 OB FTRK 202 OB	101 101
RTXF-11609P	w/ 1.75" Push Type I/S w/ 2" Pull Type I/S	FTRK 202 OB FTRK 202 OB	101 101
RTXF-11609R	w/ 1.75" Push Type I/S w/ 2" Pull Type I/S	FTRK 202 OB FTRK 202 OB	101 101
RTXF-11709H		FTRK 2284 OB	115
RTXF-12509		FTRK 160 OB	99
RTXF-12609A	w/ 1.75" Push Type I/S w/ 2" Pull Type I/S	FTRK 202 OB FTRK 202 OB	101 101
RTXF-12609B	w/ 1.75" Push Type I/S w/ 2" Pull Type I/S	FTRK 202 OB FTRK 202 OB	101 101
RTXF-12609P	w/ 1.75" Push Type I/S w/ 2" Pull Type I/S	FTRK 202 OB FTRK 202 OB	101 101
RTXF-12609R	w/ 1.75" Push Type I/S w/ 2" Pull Type I/S	FTRK 202 OB FTRK 202 OB	101 101
RTXF-12709H		FTRK 2284 OB	115
RTXF-13609A		FTRK 2282 OB	114
RTXF-13609B		FTRK 2282 OB	114
RTXF-13609P		FTRK 2282 OB	114
RTXF-13609R		FTRK 2282 OB	114

Model n°	Comments	Fersa Bearing Kit	Pg.
RTXF-13709H		FTRK 2284 OB	115
RTXF-14609A		FTRK 205 OB	101
RTXF-14609B		FTRK 205 OB	101
RTXF-14609P		FTRK 205 OB	101
RTXF-14609R		FTRK 205 OB	101
RTXF-14709H		FTRK 2275 OB	114
RTXF-16709B		FTRK 2275 OB	114
RTXF-16709H		FTRK 2275 OB	114

10 Speed Models			
FM-14D310B-LST		FTRK 3522 OB	123
FM-14E310B-LAS		FTRK 4010 OB	126
FM-15D310B-LST		FTRK 3522 OB	123
FM-15E310B-LAS		FTRK 4010 OB	126
FO-10E310C-VAS		FTRK 4010 OB	126
FO-12E310C-VAS		FTRK 4010 OB	126
FO-14E310C-LAS		FTRK 4010 OB	126
FO-14E310C-VAS		FTRK 4010 OB	126
FO-16E310C-LAS		FTRK 4010 OB	126
FO-16E310C-VAS		FTRK 4010 OB	126
FOM-14E310C-LAS		FTRK 4010 OB	126
FOM-14E310C-VAS		FTRK 4010 OB	126
FOM-15E310C-LAS		FTRK 4010 OB	126
FOM-15E310C-VAS		FTRK 4010 OB	126
FOM-16E310C-LAS		FTRK 4010 OB	126
FOM-16E310C-VAS		FTRK 4010 OB	126
FR-11210B	w/ Electronic Speedometer w/ Mechanical Speedometer	FTRK 2924 OB FTRK 3132 OB	118 119
FR-12210B	w/ Electronic Speedometer w/ Mechanical Speedometer	FTRK 2924 OB FTRK 3132 OB	118 119
FR-13210B	w/ Electronic Speedometer w/ Mechanical Speedometer	FTRK 2924 OB FTRK 3132 OB	118 119
FR-14210B	w/ Electronic Speedometer w/ Mechanical Speedometer	FTRK 2924 OB FTRK 3132 OB	118 119
FR-15210B	w/ Electronic Speedometer w/ Mechanical Speedometer	FTRK 2924 OB FTRK 3132 OB	118 119
FR-9210B	w/ Electronic Speedometer w/ Mechanical Speedometer	FTRK 2924 OB FTRK 3132 OB	118 119
FRF-11210B	w/ Electronic Speedometer w/ Mechanical Speedometer	FTRK 2924 OB FTRK 3132 OB	118 119

Model n°	Comments	Fersa Bearing Kit	Pg.
EATON/FULLER			
10 Speed Models			
FRF-12210B	w/ Electronic Speedometer w/ Mechanical Speedometer	FTRK 2924 OB FTRK 3132 OB	118 119
FRF-13210B	w/ Electronic Speedometer w/ Mechanical Speedometer	FTRK 2924 OB FTRK 3132 OB	118 119
FRF-14210B	w/ Electronic Speedometer w/ Mechanical Speedometer	FTRK 2924 OB FTRK 3132 OB	118 119
FRF-15210B	w/ Electronic Speedometer w/ Mechanical Speedometer	FTRK 2924 OB FTRK 3132 OB	118 119
FRF-9210B	w/ Electronic Speedometer w/ Mechanical Speedometer	FTRK 2924 OB FTRK 3132 OB	118 119
FRO-11210B	w/ Electronic Speedometer w/ Mechanical Speedometer	FTRK 2924 OB FTRK 3132 OB	118 119
FRO-11210C	w/ Electronic Speedometer w/ Mechanical Speedometer	FTRK 2924 OB FTRK 3132 OB	118 119
FRO-12210B	w/ Electronic Speedometer w/ Mechanical Speedometer	FTRK 2924 OB FTRK 3132 OB	118 119
FRO-12210C	w/ Electronic Speedometer w/ Mechanical Speedometer	FTRK 2924 OB FTRK 3132 OB	118 119
FRO-13210B	w/ Electronic Speedometer w/ Mechanical Speedometer	FTRK 2924 OB FTRK 3132 OB	118 119
FRO-13210C	w/ Electronic Speedometer w/ Mechanical Speedometer	FTRK 2924 OB FTRK 3132 OB	118 119
FRO-14210B	w/ Electronic Speedometer w/ Mechanical Speedometer	FTRK 2924 OB FTRK 3132 OB	118 119
FRO-14210C	w/ Electronic Speedometer w/ Mechanical Speedometer	FTRK 2924 OB FTRK 3132 OB	118 119
FRO-15210B	w/ Electronic Speedometer w/ Mechanical Speedometer	FTRK 2924 OB FTRK 3132 OB	118 119
FRO-15210C	w/ Electronic Speedometer w/ Mechanical Speedometer	FTRK 2924 OB FTRK 3132 OB	118 119
FRO-16210B	w/ Electronic Speedometer w/ Mechanical Speedometer	FTRK 2924 OB FTRK 3132 OB	118 119
FRO-16210C	w/ Electronic Speedometer w/ Mechanical Speedometer	FTRK 2924 OB FTRK 3132 OB	118 119
FRO-17210C	w/ Electronic Speedometer w/ Mechanical Speedometer	FTRK 2924 OB FTRK 3132 OB	118 119
FRO-18210C	w/ Electronic Speedometer w/ Mechanical Speedometer	FTRK 2924 OB FTRK 3132 OB	118 119
FROF-11210B	w/ Electronic Speedometer w/ Mechanical Speedometer	FTRK 2924 OB FTRK 3132 OB	118 119
FROF-11210C	w/ Electronic Speedometer w/ Mechanical Speedometer	FTRK 2924 OB FTRK 3132 OB	118 119
FROF-12210B	w/ Electronic Speedometer w/ Mechanical Speedometer	FTRK 2924 OB FTRK 3132 OB	118 119
FROF-12210C	w/ Electronic Speedometer w/ Mechanical Speedometer	FTRK 2924 OB FTRK 3132 OB	118 119
FROF-13210B	w/ Electronic Speedometer w/ Mechanical Speedometer	FTRK 2924 OB FTRK 3132 OB	118 119
FROF-13210C	w/ Electronic Speedometer w/ Mechanical Speedometer	FTRK 2924 OB FTRK 3132 OB	118 119
FROF-14210B	w/ Electronic Speedometer w/ Mechanical Speedometer	FTRK 2924 OB FTRK 3132 OB	118 119

Model n°	Comments	Fersa Bearing Kit	Pg.
FROF-14210C	w/ Electronic Speedometer w/ Mechanical Speedometer	FTRK 2924 OB FTRK 3132 OB	118 119
FROF-15210B	w/ Electronic Speedometer w/ Mechanical Speedometer	FTRK 2924 OB FTRK 3132 OB	118 119
FROF-15210C	w/ Electronic Speedometer w/ Mechanical Speedometer	FTRK 2924 OB FTRK 3132 OB	118 119
FROF-16210B	w/ Electronic Speedometer w/ Mechanical Speedometer	FTRK 2924 OB FTRK 3132 OB	118 119
FROF-16210C	w/ Electronic Speedometer w/ Mechanical Speedometer	FTRK 2924 OB FTRK 3132 OB	118 119
FRW-15210B		FTRK 2924 OB	118
FRWF-15210B		FTRK 2924 OB	118
RT-11610	w/ 1.75" Push Type I/S w/ 2" Pull Type I/S	FTRK 202 OB FTRK 202 OB	101 101
RT-11710B		FTRK 2049 OB	113
RT-12510		FTRK 160 OB	99
RT-12610	w/ 1.75" Push Type I/S w/ 2" Pull Type I/S	FTRK 202 OB FTRK 2761 OB	101 116
RT-12710B		FTRK 2049 OB	113
RT-13710B		FTRK 2284 OB	115
RT-14610		FTRK 205 OB	101
RT-14710B		FTRK 2277 OB	114
RT-14910B-AS2		FTRK 3522 OB	123
RT-6610	w/ 30mm Aux C/S Front Bearg.	FTRK 145A OB	97
RT-6610	w/ 25mm Aux C/S Front Bearg.	FTRK 145 OB	97
RT-9710B		FTRK 3322 OB	120
RTF-11610	w/ 1.75" Push Type I/S w/ 2" Pull Type I/S	FTRK 202 OB FTRK 202 OB	101 101
RTF-11710B		FTRK 2049 OB	113
RTF-12510		FTRK 160 OB	99
RTF-12610		FTRK 202 OB FTRK 202 OB	101 101
RTF-12710B		FTRK 2049 OB	113
RTF-13710B		FTRK 2284 OB	115
RTF-14610		FTRK 205 OB	101
RTF-14710B		FTRK 2277 OB	114
RTF-9710B		FTRK 3322 OB	120
RTL-13710B		FTRK 2284 OB	115
RTL-14710B		FTRK 3553 OB	124
RTLF-13710B		FTRK 2284 OB	115
RTLF-14710B		FTRK 3553 OB	124
RTLO-11610B		FTRK 2772 OB	117
RTLO-11610B-T2		FTRK 2772 OB	117
RTLO-12610B		FTRK 2772 OB	117
RTLO-12610B-T2		FTRK 2772 OB	117
RTLO-13610B		FTRK 2772 OB	117
RTLO-13610B-T2		FTRK 2772 OB	117
RTLO-14610A		FTRK 2998 OB	119

2

2.1 \ Heavy Duty Transmission Index

Model n°	Comments	Fersa Bearing Kit	Pg.
EATON/FULLER			
10 Speed Models			
RTLO-14610B		FTRK 2773 OB	117
RTLO-14610B-T2		FTRK 2773 OB	117
RTLO-15610B		FTRK 2773 OB	117
RTLO-15610B-T2		FTRK 2773 OB	117
RTLO-16610B		FTRK 2773 OB	117
RTLO-16610B-T2		FTRK 2773 OB	117
RTLO-17610B		FTRK 2773 OB	117
RTLO-17610B-T2		FTRK 2773 OB	117
RTLO-18610B		FTRK 2773 OB	117
RTLO-18610B-T2		FTRK 2773 OB	117
RTLO-18610B-T2		FTRK 3522 OB	123
RTLOF-11610B		FTRK 2772 OB	117
RTLOF-11610B-T2		FTRK 2772 OB	117
RTLOF-12610B		FTRK 2772 OB	117
RTLOF-12610B-T2		FTRK 2772 OB	117
RTLOF-13610B		FTRK 2772 OB	117
RTLOF-13610B-T2		FTRK 2772 OB	117
RTLOF-14610B		FTRK 2773 OB	117
RTLOF-14610B-T2		FTRK 2773 OB	117
RTLOF-15610B		FTRK 2773 OB	117
RTLOF-15610B-T2		FTRK 2773 OB	117
RTLOF-16610B		FTRK 2773 OB	117
RTLOF-16610B-T2		FTRK 2773 OB	117
RTLOF-17610B		FTRK 2773 OB	117
RTLOF-17610B-T2		FTRK 2773 OB	117
RTLOF-18610B		FTRK 2773 OB	117
RTO-10710B-AS2		FTRK 3488 OB	123
RTO-10910B-AS2		FTRK 3522 OB	123
RTO-10910B-AS3		FTRK 3522 OB	123
RTO-10910B-DM2		FTRK 3522 OB	123

Model n°	Comments	Fersa Bearing Kit	Pg.
RTO-10910B-DM3		FTRK 3522 OB	123
RTO-11610	w/ 1.75" Push Type I/S w/ 2" Pull Type I/S	FTRK 202 OB FTRK 202 OB	101 101
RTO-12510		FTRK 160 OB	99
RTO-12610	w/ 1.75" Push Type I/S w/ 2" Pull Type I/S	FTRK 202 OB FTRK 202 OB	101 101
RTO-12710B-AS2		FTRK 3488 OB	123
RTO-12910B-AS2		FTRK 3522 OB	123
RTO-12910B-AS3		FTRK 3522 OB	123
RTO-12910B-DM2		FTRK 3522 OB	123
RTO-12910B-DM3		FTRK 3522 OB	123
RTO-14610		FTRK 205 OB	101
RTO-14710B-AS2		FTRK 3487 OB	123
RTO-14710C-AS2		FTRK 3487 OB	123
RTO-14910B-AS2		FTRK 3522 OB	123
RTO-14910B-AS3		FTRK 3522 OB	123
RTO-14910B-DM2		FTRK 3522 OB	123
RTO-14910B-DM3		FTRK 3522 OB	123
RTO-14910C-AS2		FTRK 3522 OB	123
RTO-14910C-AS3		FTRK 3522 OB	123
RTO-15210C	w/ Electronic Speedometer w/ Mechanical Speedometer	FTRK 2924 OB FTRK 3132 OB	118 119
RTO-16210C	w/ Electronic Speedometer w/ Mechanical Speedometer	FTRK 2924 OB FTRK 3132 OB	118 119
RTO-16710B-AS2		FTRK 3487 OB	123
RTO-16710C-AS2		FTRK 3487 OB	123
RTO-16910B-AS2		FTRK 3522 OB	123
RTO-16910B-AS3		FTRK 3522 OB	123
RTO-16910B-DM2		FTRK 3522 OB	123
RTO-16910B-DM3		FTRK 3522 OB	123
RTO-16910C-AS2		FTRK 3522 OB	123
RTO-16910C-AS3		FTRK 3522 OB	123
RTO-18910B-AS2		FTRK 3522 OB	123
RTO-18910B-AS3		FTRK 3522 OB	123

Model n°	Comments	Fersa Bearing Kit	Pg.
----------	----------	-------------------	-----

EATON/FULLER

10 Speed Models

RT-6610	w/ 25mm Aux C/S Front Bearg.	FTRK 145 OB	97
RTO-6610	w/ 30mm Aux C/S Front Bearg.	FTRK 145A OB	97
RTOF-11610	w/ 1.75" Push Type I/S	FTRK 202 OB	101
	w/ 2" Pull Type I/S	FTRK 202 OB	101
RTOF-12510		FTRK 160 OB	99
RTOF-12610	w/ 1.75" Push Type I/S	FTRK 202 OB	101
	w/ 2" Pull Type I/S	FTRK 202 OB	101
RTOF-14610		FTRK 205 OB	101
RTOF-15210C	w/ Electronic Speedometer	FTRK 2924 OB	118
	w/ Mechanical Speedometer	FTRK 3132 OB	119
RTOF-16210C	w/ Electronic Speedometer	FTRK 2924 OB	118
	w/ Mechanical Speedometer	FTRK 3132 OB	119
RTOM-16910B-DM3		FTRK 3522 OB	123
RTX-11610	w/ 1.75" Push Type I/S	FTRK 202 OB	101
	w/ 2" Pull Type I/S	FTRK 202 OB	101
RTX-11710B		FTRK 2284 OB	115
RTX-11710C		FTRK 2284 OB	115
RTX-12510		FTRK 160 OB	99
RTX-12610	w/ 1.75" Push Type I/S	FTRK 202 OB	101
	w/ 2" Pull Type I/S	FTRK 202 OB	101
RTX-12710B		FTRK 2284 OB	115
RTX-12710C		FTRK 2284 OB	115
RTX-13710B		FTRK 2284 OB	115
RTX-13710C		FTRK 2284 OB	115
RTX-14610		FTRK 205 OB	101
RTX-14710B		FTRK 2277 OB	114
RTX-14710C		FTRK 2277 OB	114
RTX-15710B		FTRK 2277 OB	114
RTX-15710C		FTRK 2277 OB	114
RTX-16710B		FTRK 2277 OB	114
RTX-16710C		FTRK 2277 OB	114
RTXF-11610	w/ 1.75" Push Type I/S	FTRK 202 OB	101
	w/ 2" Pull Type I/S	FTRK 202 OB	101
RTXF-11710B		FTRK 2284 OB	115
RTXF-11710C		FTRK 2284 OB	115
RTXF-12510		FTRK 160 OB	99
RTXF-12610	w/ 1.75" Push Type I/S	FTRK 2283 OB	115
	w/ 2" Pull Type I/S	FTRK 2283 OB	115
RTXF-12710B		FTRK 2284 OB	115
RTXF-12710C		FTRK 2284 OB	115
RTXF-13710B		FTRK 2284 OB	115
RTXF-13710C		FTRK 2284 OB	115
RTXF-14610		FTRK 205 OB	101
RTXF-14710C		FTRK 2277 OB	114
RTXF-15710B		FTRK 2277 OB	114
RTXF-15710C		FTRK 2277 OB	114
RTXF-16710B		FTRK 2277 OB	114
RTXF-16710C		FTRK 2277 OB	114

Model n°	Comments	Fersa Bearing Kit	Pg.
----------	----------	-------------------	-----

13 Speed Models

FO-14E313A-MHP		FTRK 3941 OB	125
FO-16D313E-LEP		FTRK 3512 OB	123
FO-16E313A-MHP		FTRK 3941 OB	125
FO-16E313A-VHP		FTRK 3941 OB	125
FO-18E313A-MHP		FTRK 3941 OB	125
FO-18E313A-VHP		FTRK 3941 OB	125
FO-20E313A-MHP		FTRK 3941 OB	125
FO-20E313A-VHP		FTRK 3941 OB	125
FOM-16D313E-LEP		FTRK 3512 OB	123
RT-11613	w/ Tapered Aux. C/S Brgs.	FTRK 2281 OB	114
	w/ 1.75" Push Type I/S & w/o Tapered Aux. C/S Brgs.	FTRK 202 OB	101
	w/ 2" Pull Type I/S & w/o Tapered Aux. C/S Brgs.	FTRK 202 OB	101
RT-14613	w/o Tapered Aux. C/S Brgs.	FTRK 206 OB	102
	w/ Tapered Aux. C/S Brgs.	FTRK 2280 OB	114
RT-15613	w/o Tapered Aux. C/S Brgs.	FTRK 1874 OB	110
	w/ Tapered Aux. C/S Brgs.	FTRK 2280 OB	114
RT-6613		FTRK 146 OB	97
RT-913		FTRK 1000 OB	107
RT-9513		FTRK 1000 OB	107
RTF-11613	w/ Tapered Aux. C/S Brgs.	FTRK 2281 OB	114
	w/ 1.75" Push Type I/S & w/o Tapered Aux. C/S Brgs.	FTRK 202 OB	101
	w/ 2" Pull Type I/S & w/o Tapered Aux. C/S Brgs.	FTRK 202 OB	101
RTF-12513		FTRK 149 OB	98
RTF-14613	w/o Tapered Aux. C/S Brgs.	FTRK 206 OB	102
	w/ Tapered Aux. C/S Brgs.	FTRK 2280 OB	114
RTF-15613	w/o Tapered Aux. C/S Brgs.	FTRK 1874 OB	110
	w/ Tapered Aux. C/S Brgs.	FTRK 2280 OB	114
RTLO-12713A		FTRK 2285 OB	115
RTLO-12913A	w/ Forced Lubrication	FTRK 3343 OB	120
RTLO-12913A	w/o Forced Lubrication	FTRK 3351 OB	121
RTLO-14613B		FTRK 2996 OB	118
RTLO-14713A		FTRK 2286 OB	115
RTLO-14913A	w/ Forced Lubrication	FTRK 3343 OB	120
RTLO-14913A	w/o Forced Lubrication	FTRK 3348 OB	121
RTLO-16713A	w/ Serial # 51126220 & Lower	FTRK 2287 OB	115
	w/ Serial # 51126221 & Higher or Beginning with a Letter	FTRK 3346 OB	121

2.1 \ Heavy Duty Transmission Index

Model n°	Comments	Fersa Bearing Kit	Pg.
EATON/FULLER			
13 Speed Models			
RTLO-16713A-T2		FTRK 3596 OB	124
RTLO-16913A		FTRK 3343 OB	120
RTLO-16913A-T2		FTRK 3426 OB	122
RTLO-16913L-DM3		FTRK 3512 OB	123
RTLO-18913A	w/ Serial # 51126220 & Lower	FTRK 3286 OB	120
RTLO-18913A	w/ Serial # 51126221 & Higher or Beginning with a Letter	FTRK 3343 OB	120
RTLO-18913A-T2	w/ Serial # 51126220 & Lower	FTRK 3286 OB	120
	w/ Serial # 51126221 & Higher or Beginning with a Letter	FTRK 3426 OB	122
RTLO-20913A		FTRK 3460 OB	122
RTLOF-12713A		FTRK 2285 OB	115
RTLOF-12913A	w/ Forced Lubrication	FTRK 3343 OB	120
RTLOF-12913A	w/o Forced Lubrication	FTRK 3351 OB	121
RTLOF-14613B		FTRK 2996 OB	118
RTLOF-14713A		FTRK 2286 OB	115
RTLOF-14913A	w/ Forced Lubrication	FTRK 3343 OB	121
	w/o Forced Lubrication	FTRK 3348 OB	121
RTLOF-16713A	w/ Serial # 51126220 & Lower	FTRK 2287 OB	115
	w/ Serial # 51126221 & Higher or Beginning with a Letter	FTRK 3346 OB	121
RTLOF-16713A-T2		FTRK 3596 OB	124
RTLOF-16913A		FTRK 3343 OB	120
RTLOF-16913A-T2		FTRK 3426 OB	122
RTLOF-18913A	w/ Serial # 51126220 & Lower	FTRK 3286 OB	120
	w/ Serial # 51126221 & Higher or Beginning with a Letter	FTRK 3343 OB	120
RTLOF-18913A-T2	w/ Serial # 51126220 & Lower	FTRK 3286 OB	120
	w/ Serial # 51126221 & Higher or Beginning with a Letter	FTRK 3426 OB	122
RTLOF-20913A		FTRK 3460 OB	122
RTL0M-16913L-DM3		FTRK 3512 OB	123
RTO-11613	w/ Tapered Aux. C/S Brgs.	FTRK 2281 OB	114
	w/ 1.75" Push Type I/S & w/o Tapered Aux. C/S Brgs.	FTRK 2283 OB	115
	w/ 2" Pull Type I/S & w/o Tapered Aux. C/S Brgs.	FTRK 2283 OB	115

Model n°	Comments	Fersa Bearing Kit	Pg.
RTO-11813	w/ Tapered Aux. C/S Brgs.	FTRK 2281 OB	114
	w/ 1.75" Push Type I/S & w/o Tapered Aux. C/S Brgs.	FTRK 2283 OB	115
	w/ 2" Pull Type I/S & w/o Tapered Aux. C/S Brgs.	FTRK 2283 OB	115
RTO-12513		FTRK 149 OB	98
RTO-14613	w/o Tapered Aux. C/S Brgs.	FTRK 206 OB	102
	w/ Tapered Aux. C/S Brgs.	FTRK 2280 OB	114
RTO-14813	w/o Tapered Aux. C/S Brgs.	FTRK 206 OB	102
	w/ Tapered Aux. C/S Brgs.	FTRK 2280 OB	114
RTO-15613	w/o Tapered Aux. C/S Brgs.	FTRK 1874 OB	110
	w/ Tapered Aux. C/S Brgs.	FTRK 2280 OB	114
RTO-15813	w/o Tapered Aux. C/S Brgs.	FTRK 1874 OB	110
	w/ Tapered Aux. C/S Brgs.	FTRK 2280 OB	114
RTO-6613		FTRK 146 OB	97
RTOF-11613	w/ Tapered Aux. C/S Brgs.	FTRK 2281 OB	114
	w/ 1.75" Push Type I/S & w/o Tapered Aux. C/S Brgs.	FTRK 202 OB	101
	w/ 2" Pull Type I/S & w/o Tapered Aux. C/S Brgs.	FTRK 202 OB	101
RTOF-11813	w/ Tapered Aux. C/S Brgs.	FTRK 2281 OB	114
	w/ 1.75" Push Type I/S & w/o Tapered Aux. C/S Brgs.	FTRK 202 OB	101
	w/ 2" Pull Type I/S & w/o Tapered Aux. C/S Brgs.	FTRK 202 OB	101
RTOF-12513		FTRK 149 OB	98
RTOF-14613	w/o Tapered Aux. C/S Brgs.	FTRK 206 OB	102
	w/ Tapered Aux. C/S Brgs.	FTRK 2280 OB	114
RTOF-14813	w/o Tapered Aux. C/S Brgs.	FTRK 206 OB	102
	w/ Tapered Aux. C/S Brgs.	FTRK 2280 OB	114
RTOF-15613	w/o Tapered Aux. C/S Brgs.	FTRK 1874 OB	110
	w/ Tapered Aux. C/S Brgs.	FTRK 2280 OB	114
RTOF-15813	w/o Tapered Aux. C/S Brgs.	FTRK 1874 OB	110
	w/ Tapered Aux. C/S Brgs.	FTRK 2280 OB	114
RTOO-11613	w/ Tapered Aux. C/S Brgs.	FTRK 2281 OB	114
	w/ 1.75" Push Type I/S & w/o Tapered Aux. C/S Brgs.	FTRK 202 OB	101
	w/ 2" Pull Type I/S & w/o Tapered Aux. C/S Brgs.	FTRK 202 OB	101
RTOO-14613	w/o Tapered Aux. C/S Brgs.	FTRK 206 OB	102
	w/ Tapered Aux. C/S Brgs.	FTRK 2280 OB	114
RTOOF-11613	w/ Tapered Aux. C/S Brgs.	FTRK 2281 OB	114
	w/ 1.75" Push Type I/S & w/o Tapered Aux. C/S Brgs.	FTRK 202 OB	101
	w/ 2" Pull Type I/S & w/o Tapered Aux. C/S Brgs.	FTRK 202 OB	101
RTOOF-14613	w/o Tapered Aux. C/S Brgs.	FTRK 206 OB	102
	w/ Tapered Aux. C/S Brgs.	FTRK 2280 OB	114
RTOX-11613	w/ Tapered Aux. C/S Brgs.	FTRK 2281 OB	114
RTOX-11613	w/ 1.75" Push Type I/S & w/o Tapered Aux. C/S Brgs.	FTRK 202 OB	101
RTOX-11613	w/ 2" Pull Type I/S & w/o Tapered Aux. C/S Brgs.	FTRK 202 OB	101
RTOX-14613	w/o Tapered Aux. C/S Brgs.	FTRK 206 OB	102
RTOX-14613	w/ Tapered Aux. C/S Brgs.	FTRK 2280 OB	114

Model n°	Comments	Fersa Bearing Kit	Pg.
EATON/FULLER			
13 Speed Models			
RTOXF-11613	w/ Tapered Aux. C/S Brgs.	FTRK 2281 OB	114
	w/ 1.75" Push Type I/S & w/o Tapered Aux. C/S Brgs.	FTRK 202 OB	101
	w/ 2" Pull Type I/S & w/o Tapered Aux. C/S Brgs.	FTRK 202 OB	101
RTOXF-14613	w/o Tapered Aux. C/S Brgs.	FTRK 206 OB	102
	w/ Tapered Aux. C/S Brgs.	FTRK 2280 OB	114

13 Speed Models Aux Section Only			
RT-11613 AUX		FTRK 1000AUX OB	108
RT-14613 AUX	w/o Tapered Aux. C/S Brgs.	FTRK 149AUX OB	98
	w/ Tapered Aux. C/S Brgs.	FTRK 2340 OB	115
RT-15613 AUX	w/o Tapered Aux. C/S Brgs.	FTRK 149AUX OB	98
	w/ Tapered Aux. C/S Brgs.	FTRK 2340 OB	115
RTF-11613 AUX		FTRK 1000AUX OB	108
RTF-14613 AUX	w/o Tapered Aux. C/S Brgs.	FTRK 149AUX OB	98
	w/ Tapered Aux. C/S Brgs.	FTRK 2340 OB	115
RTF-15613 AUX	w/o Tapered Aux. C/S Brgs.	FTRK 149AUX OB	98
	w/ Tapered Aux. C/S Brgs.	FTRK 2340 OB	115
RTLO-12713A AUX		FTRK 2768 OB	117
RTLO-14613B AUX		FTRK 2338 OB	115
RTLO-14713A AUX		FTRK 2759 OB	116
RTLO-16713A AUX	w/ Serial # 51126220 & Lower	FTRK 2769 OB	117
	w/ Serial # 51126221 & Higher or Beginning with a Letter	FTRK 3344 OB	121
RTLOF-12713A AUX		FTRK 2768 OB	117
RTLOF-14613B AUX		FTRK 2338 OB	115
RTLOF-14713A AUX		FTRK 2759 OB	116
RTLOF-16713A AUX	w/ Serial # 51126220 & Lower	FTRK 2769 OB	117
	w/ Serial # 51126221 & Higher or Beginning with a Letter	FTRK 3344 OB	121
RTO-11613 AUX		FTRK 1555 OB	108
		FTRK 1555 OB	108
RTO-14613 AUX	w/o Tapered Aux. C/S Brgs.	FTRK 149AUX OB	98
	w/ Tapered Aux. C/S Brgs.	FTRK 2340 OB	115
RTO-14813 AUX	w/o Tapered Aux. C/S Brgs.	FTRK 149AUX OB	98

Model n°	Comments	Fersa Bearing Kit	Pg.
RTO-14813 AUX	w/ Tapered Aux. C/S Brgs.	FTRK 2340 OB	116
RTO-15613 AUX	w/o Tapered Aux. C/S Brgs.	FTRK 149AUX OB	98
	w/ Tapered Aux. C/S Brgs.	FTRK 2340 OB	116
RTO-15813 AUX	w/o Tapered Aux. C/S Brgs.	FTRK 149AUX OB	98
	w/ Tapered Aux. C/S Brgs.	FTRK 2340 OB	116
RTOF-11613 AUX		FTRK 1000AUX OB	107
RTOF-11813 AUX		FTRK 1000AUX OB	108
RTOF-14613 AUX	w/o Tapered Aux. C/S Brgs.	FTRK 149AUX OB	98
	w/ Tapered Aux. C/S Brgs.	FTRK 2340 OB	116
RTOF-14813 AUX	w/o Tapered Aux. C/S Brgs.	FTRK 149AUX OB	98
	w/ Tapered Aux. C/S Brgs.	FTRK 2340 OB	116
RTOF-15613 AUX	w/o Tapered Aux. C/S Brgs.	FTRK 149AUX OB	98
RTOF-15613 AUX	w/ Tapered Aux. C/S Brgs.	FTRK 2340 OB	116
RTOF-15813 AUX	w/o Tapered Aux. C/S Brgs.	FTRK 149AUX OB	98
	w/ Tapered Aux. C/S Brgs.	FTRK 2340 OB	116
RTO0-11613 AUX		FTRK 1000AUX OB	108
RTO0-14613 AUX	w/o Tapered Aux. C/S Brgs.	FTRK 149AUX OB	98
	w/ Tapered Aux. C/S Brgs.	FTRK 2340 OB	116
RTO0F-11613 AUX		FTRK 1000AUX OB	108
RTO0F-14613 AUX	w/o Tapered Aux. C/S Brgs.	FTRK 149AUX OB	98
	w/ Tapered Aux. C/S Brgs.	FTRK 2340 OB	116
RTOX-11613 AUX		FTRK 1000AUX OB	108
RTOX-14613 AUX	w/o Tapered Aux. C/S Brgs.	FTRK 149AUX OB	98
	w/ Tapered Aux. C/S Brgs.	FTRK 2340 OB	116
RTOXF-11613 AUX		FTRK 1000AUX OB	108
RTOXF-14613 AUX	w/o Tapered Aux. C/S Brgs.	FTRK 149AUX OB	98
	w/ Tapered Aux. C/S Brgs.	FTRK 2340 OB	116

15 Speed Models			
RT-11615	w/ 1.75" Push Type I/S	FTRK 203 OB	101
	w/ 2" Pull Type I/S	FTRK 203 OB	101
RT-11715		FTRK 3660 OB	125
RT-12515	w/ 55mm Front Countershaft Brgs.	FTRK 159 OB	99
	w/ 45mm Front Countershaft Brgs.	FTRK 159A OB	99
RT-14615		FTRK 207 OB	102
RT-14715		FTRK 2043 OB	112
RT-14915		FTRK 3256 OB	119

2.1 \ Heavy Duty Transmission Index

Model n°	Comments	Fersa Bearing Kit	Pg.
EATON/FULLER			
15 Speed Models			
RT-15615		FTRK 202 OB	101
RT-15715		FTRK 2043 OB	112
RT-915		FTRK 1000 OB	108
RTF-11615	w/ 1.75" Push Type I/S	FTRK 203 OB	101
	w/ 2" Pull Type I/S	FTRK 203 OB	101
RTF-11715		FTRK 3660 OB	125
RTF-12515	w/ 55mm Front Countershaft Brgs.	FTRK 159 OB	99
	w/ 45mm Front Countershaft Brgs.	FTRK 159A OB	99
RTF-14615		FTRK 207 OB	102
RTF-14715		FTRK 2043 OB	112
RTF-14915		FTRK 3256 OB	119
RTF-15615		FTRK 202 OB	101
RTF-15715		FTRK 2043 OB	112
RTO-11615	w/ 1.75" Push Type I/S	FTRK 203 OB	101
	w/ 2" Pull Type I/S	FTRK 203 OB	101
RTO-11715		FTRK 3660 OB	125
RTO-12515	w/ 45mm Front Countershaft Brgs.	FTRK 159A OB	99
	w/ 55mm Front Countershaft Brgs.	FTRK 159 OB	99
RTO-14615		FTRK 207 OB	102
RTO-14715		FTRK 2043 OB	112
RTO-14915	w/ 85mm Aux Drive Gear	FTRK 3233 OB	119
	w/ 90mm Aux Drive Gear	FTRK 3256 OB	119
RTO-15615		FTRK 202 OB	101
RTO-15715		FTRK 2043 OB	112
RTO-16915		FTRK 3233 OB	119
RTOF-11615	w/ 1.75" Push Type I/S	FTRK 203 OB	101
	w/ 2" Pull Type I/S	FTRK 203 OB	101
RTOF-11715		FTRK 3660 OB	125
RTOF-12515	w/ 45mm Front Countershaft Brgs.	FTRK 159A OB	99
RTOF-12515	w/ 55mm Front Countershaft Brgs.	FTRK 159 OB	99
RTOF-14615		FTRK 207 OB	102
RTOF-14715		FTRK 2043 OB	112
RTOF-14915	w/ 85mm Aux Drive Gear	FTRK 3233 OB	119
	w/ 90mm Aux Drive Gear	FTRK 3256 OB	119
RTOF-15615		FTRK 202 OB	101
RTOF-15715		FTRK 2043 OB	112
RTOF-16915		FTRK 3233 OB	119
RTX-11615	w/ 1.75" Push Type I/S	FTRK 203 OB	101
	w/ 2" Pull Type I/S	FTRK 203 OB	101
RTX-11715		FTRK 3660 OB	125
RTX-12515		FTRK 159A OB	99
RTX-14615		FTRK 207 OB	102
RTX-14715		FTRK 2043 OB	112
RTX-15615		FTRK 202 OB	101
RTX-15715		FTRK 2043 OB	112
RTXF-11615	w/ 1.75" Push Type I/S	FTRK 203 OB	101
	w/ 2" Pull Type I/S	FTRK 203 OB	101

Model n°	Comments	Fersa Bearing Kit	Pg.
RTXF-11715		FTRK 3660 OB	125
RTXF-12515		FTRK 159A OB	99
RTXF-14615		FTRK 207 OB	102
RTXF-14715		FTRK 2043 OB	112
RTXF-15615		FTRK 202 OB	101
RTXF-15715		FTRK 2043 OB	112

18 Speed Models			
FO-14E318B-MXP		FTRK 3941 OB	125
FO-14E318B-VXP		FTRK 3941 OB	125
FO-16E318B-MXP		FTRK 3941 OB	125
FO-16E318B-VXP		FTRK 3941 OB	125
FO-18E318B-MXP		FTRK 3941 OB	125
FO-18E318B-VXP		FTRK 3941 OB	125
FO-20E318B-MXP		FTRK 3941 OB	125
FO-20E318B-VXP		FTRK 3941 OB	125
FO-22E318B-MXP		FTRK 3941 OB	125
FO-22E318B-VXP		FTRK 3941 OB	125
RTLO-14618A		FTRK 2996 OB	118
RTLO-14718B		FTRK 2288 OB	115
RTLO-14918A-AS2		FTRK 3512 OB	123
RTLO-14918A-AS3		FTRK 3512 OB	123
RTLO-14918B	w/ Forced Lubrication w/o Forced Lubrication	FTRK 3340 OB FTRK 3355 OB	120 121
RTLO-14918B-AS		FTRK 3534 OB	124
RTLO-14918B-T2		FTRK 3355 OB	121
RTLO-16618A		FTRK 2996 OB	118
RTLO-16718B		FTRK 2288 OB	115
RTLO-16918A-AS2		FTRK 3512 OB	123
RTLO-16918A-AS3		FTRK 3512 OB	123
RTLO-16918B		FTRK 3340 OB	120
RTLO-16918B-AS		FTRK 3534 OB	124
RTLO-16918B-T2		FTRK 3340 OB	120
RTLO-18718B		FTRK 2865 OB	118
RTLO-18718B-T2		FTRK 2865 OB	118
RTLO-18918A-AS2		FTRK 3512 OB	123

2.1 \ Heavy Duty Transmission Index

Model No.	Speeds	Comments	Bearing Kit	Pg.
GMC				
CH465	4	Early/Late	FTRK 157A OB	98
	4	1979 - 1990	FTRK 157L OB	98
	4	1990 and Later	FTRK 157B OB	98
SM465	4	Early/Late	FTRK 157A OB	98
	4	1979 - 1990	FTRK 157L OB	98
	4	1990 and Later	FTRK 157B OB	98

International Harvester/Navistar

T32	5		FTRK 156 OB	98
T33	5		FTRK 156 OB	98
T34	5		FTRK 156 OB	98
T35	5		FTRK 156 OB	98
T36	5		FTRK 156 OB	98
T494	5		FTRK 156 OB	98
T495	5		FTRK 156 OB	98
T496	5		FTRK 156 OB	98
T698	5		FTRK 183 OB	100
T699	5		FTRK 183 OB	100

MACK

TRQP72	20	w/o Clutch Brake	FTRK 65 OB	95
TR107	5		FTRK 185 OB	100
TRDXL107	6		FTRK 500 OB	105
TRTXL107	12	Super Duty	FTRK 213SD OB	102
TRXL107	6		FTRK 187 OB	100
TRXL107A	6		FTRK 187 OB	100
TC150	-	Transfer Case	FTRK 504 OB	105
T309L	9		FTRK 505 OB	105
	9	Master Kit	FTRK 505MK OB	105
T310	10		FTRK 506 OB	106
	10	Master Kit	FTRK 506 OB	106
T318	18		FTRK 507 OB	106
	18	Master Kit	FTRK 507MK OB	106
TRQ720	20	w/o Clutch Brake	FTRK 65 OB	95
TRQP720	20	w/o Clutch Brake	FTRK 65 OB	95
TRDL1070	10		FTRK 187 OB	100
TRTXL1070	12	Super Duty	FTRK 213SD OB	102
	12		FTRK 213 OB	102
TRXL1070	-		FTRK 502 OB	105
TRTXL1070	12		FTRK 213 OB	102
TRXL1071	6		FTRK 187 OB	100
TRXL1071A	6		FTRK 187 OB	100
TRL1076	5		FTRK 185 OB	100
TRL1078	5		FTRK 185 OB	100
T2090	9		FTRK 214 OB	103
T2050	5		FTRK 503 OB	105
T2060	6		FTRK 214 OB	103
T2060	6	Master Kit	FTRK 214MK OB	103
T2070	7		FTRK 214 OB	103
T2070	7	Master Kit	FTRK 214MK OB	103
T2080	8		FTRK 214 OB	103
T2090	9		FTRK 214 OB	103
	9	Master Kit	FTRK 214MK OB	103

Model No.	Speeds	Comments	Bearing Kit	Pg.
T2100	10		FTRK 214 OB	103
	10	Master Kit	FTRK 214MK OB	103
T2130	13		FTRK 214 OB	103
	13	Master Kit	FTRK 214MK OB	103
T2180	18		FTRK 214 OB	103
	18	Master Kit	FTRK 214MK1 OB	103
TRQ7210	20	w/o Clutch Brake	FTRK 65 OB	95
TRQL7220	20	w/o Clutch Brake	FTRK 65 OB	95
TRXL10710	-		FTRK 502 OB	105
TRL10760	-		FTRK 501 OB	105
TRL10780	-		FTRK 501 OB	105

Meritor/Rockwell

RM9-115	9		FTRK 5356 OB	126
RM9-125	9		FTRK 5356 OB	126
RM9-135	9		FTRK 5357 OB	126
RM9-145	9		FTRK 5357 OB	126
RM9-155	9		FTRK 5357 OB	126
RM10-115	10		FTRK 5356 OB	126
RM10-125	10		FTRK 5356 OB	126
RM10-135	10		FTRK 5357 OB	126
RM10-145	10		FTRK 5357 OB	126
RM10-155	10		FTRK 5357 OB	126
RM10-165	10		FTRK 5357 OB	126
RM13-145	10		FTRK 5358 OB	126
M-15G9	9		FTRK 5406 OB	126
M-15G10	10		FTRK 5406 OB	126
MO-14G9	9		FTRK 5406 OB	126
MO-15G9	9		FTRK 5406 OB	126
MO-16G10	10		FTRK 5406 OB	126

New Process Transmissions

435	4	w/ Tapered Bearing on Drive Shaft	FTRK 127 OB	96
	4	Ford only w/ Tapered Bearing on Drive Shaft	FTRK 127F OB	96
	4	w/ Ball Bearing on Drive Shaft	FTRK 127G OB	96
435FE	4	w/ Tapered Bearing on Drive Shaft	FTRK 127 OB	96
435FL	4	w/ Tapered Bearing on Drive Shaft	FTRK 127 OB	96
435GL	4	w/ Tapered Bearing on Drive Shaft	FTRK 127 OB	96
436	4	w/ Tapered Bearing on Drive Shaft	FTRK 127 OB	96
	4	Ford only w/ Tapered Bearing on Drive Shaft	FTRK 127F OB	96
	4	w/ Ball Bearing on Drive Shaft	FTRK 127G OB	96
540	5		FTRK 27 OB	94

Model No.	Speeds	Comments	Bearing Kit	Pg.
Spicer/TTC Transmissions				
540C	5		FTRK 27 OB	94
540D	5		FTRK 27 OB	94
540G	5		FTRK 27 OB	94
540GD	5		FTRK 27 OB	94
540GL	5		FTRK 27 OB	94
540GO	5		FTRK 27 OB	94
541	5	Early	FTRK 27 OB	94
	5	Late (Exc. Ford)	FTRK 29 OB	94
541DD11	5		FTRK 29 OB	94
541DD12	5		FTRK 29 OB	94
541DD13	5		FTRK 29 OB	94
541DD14	5		FTRK 29 OB	94
541DD15	5		FTRK 29 OB	94
541DD16	5		FTRK 29 OB	94
541DD17	5		FTRK 29 OB	94
541FD	5	Early	FTRK 27 OB	94
	5	Late	FTRK 29 OB	94
541FL	5	Early	FTRK 27 OB	94
	5	Late	FTRK 29 OB	94
541FO	5	Early	FTRK 27 OB	94
	5	Late	FTRK 29 OB	94
541G	5	Early	FTRK 27 OB	94
	5	Late	FTRK 29 OB	94
541GD	5	Early	FTRK 27 OB	94
	5	Late	FTRK 29 OB	94
541GD24	5	Early	FTRK 27 OB	94
	5	Late	FTRK 29 OB	94
541GL	5	Early	FTRK 27 OB	94
	5	Late	FTRK 29 OB	94
541GO	5	Early	FTRK 27 OB	94
	5	Late	FTRK 29 OB	94
541GO-11	5	Early	FTRK 27 OB	94
	5	Late	FTRK 29 OB	94
542	5	Early	FTRK 27 OB	94
	5	Late (Exc. Ford)	FTRK 29 OB	94
	5	Late (w/Ford)	FTRK 29B OB	95
542D	5	w/GMC	FTRK 29 OB	94
542FD	5	Early	FTRK 27 OB	94
	5	Late (Exc. Ford)	FTRK 29 OB	94
	5	Late (w/Ford)	FTRK 29B OB	95
542FL	5	Early	FTRK 27 OB	94
	5	Late (Exc. Ford)	FTRK 29 OB	94
	5	Late (w/Ford)	FTRK 29B OB	95
542FO	5	Early	FTRK 27 OB	94
	5	Late (Exc. Ford)	FTRK 29 OB	94
	5	Late (w/Ford)	FTRK 29B OB	95
542GD	5	w/GMC	FTRK 29 OB	94
542GL	5	w/GMC	FTRK 29 OB	94
542L	5	w/GMC	FTRK 29 OB	94
4590(IH)	4		FTRK 174 OB	99
7531	5		FTRK 177 OB	99
7550	5		FTRK 177 OB	99
7551	5		FTRK 177 OB	99
7590	5		FTRK 177 OB	99

Model No.	Speeds	Comments	Bearing Kit	Pg.
7591	5		FTRK 177 OB	99
1007	7		FTRK 189 OB	100
1010	10		FTRK 152 OB	98
1020	20		FTRK 189 OB	100
1052	5		FTRK 147 OB	97
1062	6		FTRK 147 OB	97
1064	6		FTRK 147 OB	97
1107	7		FTRK 181 OB	99
1207	7		FTRK 191 OB	101
1214	14		FTRK 189 OB	100
1252	5		FTRK 147 OB	97
1253	5		FTRK 147 OB	97
1262	6		FTRK 147 OB	97
1263	6		FTRK 147 OB	97
1272	7		FTRK 189 OB	100
1352	5		FTRK 192 OB	101
1362	6		FTRK 192 OB	101
1364	6		FTRK 192 OB	101
1372	7		FTRK 193 OB	101
1412	12		FTRK 194 OB	101
1414	14		FTRK 194 OB	101
1420	20		FTRK 194 OB	101
1452	5		FTRK 192 OB	101
1453	5		FTRK 192 OB	101
1463	6		FTRK 192 OB	101
4054	5		FTRK 210 OB	102
4652	5		FTRK 28 OB	94
4752	5		FTRK 28 OB	94
4753	5		FTRK 28 OB	94
4756	5		FTRK 28 OB	94
4852	5		FTRK 28 OB	94
4853	5		FTRK 28 OB	94
4954	5		FTRK 221 OB	103
5052	5		FTRK 180 OB	99
5252	5		FTRK 180 OB	99
5552	5		FTRK 180 OB	99
5650	5		FTRK 28 OB	94
5652	5		FTRK 28 OB	94
5750	5		FTRK 28 OB	94
5752	5		FTRK 28 OB	94
5753	5		FTRK 28 OB	94
5756	5		FTRK 28 OB	94
5850	5		FTRK 28 OB	94
5852	5		FTRK 180 OB	99
5853	5		FTRK 28 OB	94
6052	5		FTRK 186 OB	100
6252	5		FTRK 186 OB	100
6253	5		FTRK 186 OB	100
6350	5		FTRK 72 OB	95
6352	5		FTRK 72 OB	95
6354	5		FTRK 72 OB	95
6450	5		FTRK 72 OB	95
6452	5		FTRK 72 OB	95
6453	5		FTRK 72 OB	95
6454	5		FTRK 72 OB	95

2.1 \ Heavy Duty Transmission Index

Model No.	Speeds	Comments	Bearing Kit	Pg.	Model No.	Speeds	Comments	Bearing Kit	Pg.
Spicer/TTC Transmissions					CM62	5		FTRK 186 OB	100
6455	5		FTRK 72 OB	95	CM4054	5		FTRK 210 OB	102
6456	5		FTRK 72 OB	95	CM4954	5		FTRK 221 OB	103
6458	5		FTRK 72 OB	95	CM5052	5		FTRK 180 OB	99
6850	5		FTRK 72 OB	95	CM5252	5		FTRK 180 OB	99
6852	5		FTRK 72 OB	95	CM5552	5		FTRK 180 OB	99
6853	5		FTRK 72 OB	95	CM5852	5		FTRK 180 OB	99
6854	5		FTRK 72 OB	95	CM5952	5		FTRK 180 OB	99
6855	5		FTRK 72 OB	95	CM6052	5		FTRK 186 OB	100
7041	4		FTRK 73 OB	95	CM6253	5		FTRK 186 OB	100
8012	12		FTRK 74 OB	96	ES066-7B	7		FTRK 222 OB	103
8016	16		FTRK 74 OB	96	ES42-5	5		FTRK 219 OB	103
8051	5	w/ Spherical Pilot ,exc. some late models	FTRK 2 OB	94	ES43-5	5		FTRK 221 OB	103
	5	w/ Cylindrical Pilot ,exc. some late models	FTRK 2A OB	94	ES46-5A	5		FTRK 704 OB	107
8055	5	w/ Spherical Pilot ,exc. some late models	FTRK 2 OB	94	ES52-5	5		FTRK 221 OB	103
	5	w/ Cylindrical Pilot ,exc. some late models	FTRK 2A OB	94	ES52-7	7		FTRK 222 OB	103
8212	12		FTRK 74 OB	96	ES53-5	5		FTRK 221 OB	103
8216	16		FTRK 74 OB	96	ES56-5A	5		FTRK 704 OB	107
8251	5	w/ Spherical Pilot ,exc. some late models	FTRK 2 OB	94	ES56-7	7		FTRK 222 OB	103
	5	w/ Cylindrical Pilot ,exc. some late models	FTRK 2A OB	94	ES60-5	5		FTRK 180 OB	99
8255	5	w/ Spherical Pilot ,exc. some late models	FTRK 2 OB	94	ES62-5	5		FTRK 180 OB	99
	5	w/ Cylindrical Pilot ,exc. some late models	FTRK 2A OB	94	ES65-5	5		FTRK 186 OB	100
8516	16		FTRK 130 OB	96	ES65-7	7		FTRK 222 OB	103
8542	4		FTRK 139 OB	97	ES066-7	7		FTRK 222 OB	103
8544	4		FTRK 139 OB	97	ES70-5	5		FTRK 186 OB	100
8552	5		FTRK 140 OB	97	LLPS145-10	10		FTRK 700 OB	107
8553	5		FTRK 141 OB	97	LLPS0140-10	10		FTRK 700 OB	107
8554	5		FTRK 140 OB	97	LLPS0150-10	10		FTRK 700 OB	107
8555	5		FTRK 141 OB	97	LPS100-10	10		FTRK 700 OB	107
8716	16		FTRK 130 OB	96	LPS125-10	10		FTRK 700 OB	107
8742	4		FTRK 139 OB	97	LPS125-9	9		FTRK 700 OB	107
8744	4		FTRK 139 OB	97	LPS135-10	10		FTRK 700 OB	107
8753	5		FTRK 141 OB	97	LPS145-10	10		FTRK 700 OB	107
8755	5		FTRK 141 OB	97	LPS0125-10	10		FTRK 700 OB	107
8842	4		FTRK 139 OB	97	LPS0140-10	10		FTRK 700 OB	107
8844	4		FTRK 139 OB	97	LPS0150-10	10		FTRK 700 OB	107
CM40	5		FTRK 210 OB	102	PS100-10	10		FTRK 700 OB	107
CM49	5		FTRK 221 OB	103	PS105-7LL	7		FTRK 705 OB	107
CM50	5		FTRK 180 OB	99	PS110-7	7		FTRK 702 OB	107
CM55	5		FTRK 180 OB	99	PS125-9	9		FTRK 700 OB	107
CM60	5		FTRK 186 OB	100	PS130-6L	6		FTRK 705 OB	107
					PS135-10	10		FTRK 700 OB	107
					PS145-10	10		FTRK 700 OB	107
					PS145-7	7		FTRK 702 OB	107
					PS95-9	9		FTRK 700 OB	107
					PS97-7	7		FTRK 706 OB	107
					PS0100-10	10		FTRK 700 OB	107
					PS0125-10	10		FTRK 700 OB	107
					PS0140-10	10		FTRK 700 OB	107
					PS0140-9	9		FTRK 700 OB	107
					PS0150-10	10		FTRK 700 OB	107
					PS0150-16	16		FTRK 194 OB	101
					PS0150-9	9		FTRK 700 OB	107
					PS0165-10	10		FTRK 700 OB	107

Model No.	Speeds	Comments	Bearing Kit	Pg.
Spicer/TTC Transmissions				
PSO165-16	16		FTRK 194 OB	101
PSO175-16	16		FTRK 194 OB	101
SST5	5	Old Version	FTRK 147 OB	97
SST6	6	Old Version	FTRK 147 OB	97
	6	New Version	FTRK 192 OB	101
SST6+1	7	New Version	FTRK 191 OB	101
SST7	7	Old Version	FTRK 181 OB	99
	7	New Version	FTRK 193 OB	101
SST10	10	Old Version	FTRK 152 OB	98
SST12	12	New Version	FTRK 194 OB	101
SST14	14	Old Version	FTRK 189 OB	100
SST14	14	New Version	FTRK 194 OB	101
SST20	20		FTRK 189 OB	100
1241	4		FTRK 158 OB	99
6041	4		FTRK 70 OB	95
7041	4		FTRK 73 OB	95
7231	3		FTRK 86 OB	96
8031	3	w/ Steel Caged Brgs.	FTRK 3 OB	94
	3	w/ Bronze Caged Brgs.	FTRK 4 OB	94
8035	3	w/ Steel Caged Brgs.	FTRK 3 OB	94
	3	w/ Bronze Caged Brgs.	FTRK 4 OB	94
8341	4	w/ Steel Caged Brgs.	FTRK 3 OB	94
	4	w/ Bronze Caged Brgs.	FTRK 4 OB	94
8341L	4		FTRK 155 OB	98
8345	4	w/ Steel Caged Brgs.	FTRK 3 OB	94
	4	w/ Bronze Caged Brgs.	FTRK 4 OB	94
AM01000	4		FTRK 703 OB	107
AM01750	4		FTRK 703 OB	107
AP01000	4		FTRK 703 OB	107
AP01750	4		FTRK 703 OB	107
R8341C	4		FTRK 155 OB	98
R8341L	4		FTRK 155 OB	98
RP8341	4		FTRK 155 OB	98

Volvo

AT2412C	12	Early Planet (70mm O/S)	FTRK 510 OB	106
	12	Late Planet (80mm O/S)	FTRK 510A OB	106
AT2412D	12	Early Planet (70mm O/S)	FTRK 510 OB	106
	12	Late Planet (80mm O/S)	FTRK 510A OB	106
AT2512C	12	Early Planet (70mm O/S)	FTRK 511 OB	106
	12	Late Planet (80mm O/S)	FTRK 511A OB	107
AT02512C	12	Early Planet (70mm O/S)	FTRK 510 OB	106
	12	Late Planet (80mm O/S)	FTRK 510A OB	106

Model No.	Speeds	Comments	Bearing Kit	Pg.
AT2612D	12	Early Planet (70mm O/S)	FTRK 511 OB	106
	12	Late Planet (80mm O/S)	FTRK 511A OB	107
AT02612D	12	Early Planet (70mm O/S)	FTRK 510 OB	106
	12	Late Planet (80mm O/S)	FTRK 510A OB	106
AT2812C	12	Early Planet (70mm O/S)	FTRK 511 OB	106
	12	Late Planet (80mm O/S)	FTRK 511A OB	107
AT2812D	12	Early Planet (70mm O/S)	FTRK 511 OB	106
	12	Late Planet (80mm O/S)	FTRK 511A OB	107
AT03112C	12	Early Planet (70mm O/S)	FTRK 511 OB	106
	12	Late Planet (80mm O/S)	FTRK 511A OB	107
AT03112D	12	Early Planet (70mm O/S)	FTRK 511 OB	106
	12	Late Planet (80mm O/S)	FTRK 511A OB	107

WARNER

T18	4	w/Willys Jeep	FTRK 82F OB	96
	4	w/Ford	FTRK 82F OB	96
T184	4	w/I.H.	FTRK 82D OB	96
T18A	4	w/Willys Jeep	FTRK 82F OB	96
	4	w/Ford	FTRK 82F OB	96
	4	w/I.H.	FTRK 82D OB	96
T18B	4	w/Willys Jeep	FTRK 82F OB	96
	4	w/Ford	FTRK 82F OB	96
	4	w/I.H.	FTRK 82D OB	96
T18C	4	w/Willys Jeep	FTRK 82F OB	96
	4	w/Ford	FTRK 82F OB	96
	4	w/I.H.	FTRK 82D OB	96
T19	4	w/Ford (Gas)	FTRK 82F OB	96
	4	w/Ford (Diesel)	FTRK 82FD OB	96
	4	w/I.H.	FTRK 82D OB	96
T19A	4	w/Ford (Gas)	FTRK 82F OB	96
	4	w/Ford (Diesel)	FTRK 82FD OB	96
	4	w/I.H.	FTRK 82D OB	96
T98	4	w/.9055" Wide Driveshaft Bearing	FTRK 82 OB	96
T98A	4	w/.9055" Wide Driveshaft Bearing w/LH PTO	FTRK 82 OB	96
T98B	4	w/.9055" Wide Driveshaft Bearing	FTRK 82 OB	96
T98D	4	w/.9055" Wide Driveshaft Bearing	FTRK 82 OB	96

2.2 \ F-Box Transmission Rebuild Kit

POSITION	FERSA	QTY
FTRK 2 OB		
Input Shaft	6313 Z	1
Input Shaft Pilot	*	1
Output Shaft Center	*	1
Output Shaft Rear	*	1
Countershaft Front	*	1
Countershaft Rear	*	1
Rev. Idler Gear	*	2
1st Gear	*	1
2nd Gear	*	1
3rd Gear	*	1

FTRK 2A OB		
Input Shaft	6313 Z	1
Input Shaft Pilot	*	1
Output Shaft Center	*	1
Output Shaft Rear	*	1
Countershaft Front	*	1
Countershaft Rear	*	1
Rev. Idler Gear	*	2
1st Gear	*	1
2nd Gear	*	1
3rd Gear	*	1

FTRK 3 OB		
Input Shaft Front	*	1
Input Shaft Rear	*	1
Input Shaft Pilot	*	1
Output Shaft	6412 NR	1
Countershaft Front	*	1
Countershaft Rear	*	1
1st Gear	*	1
2nd Gear	*	1
3rd Gear	*	1

FTRK 4 OB		
Input Shaft Front	*	1
Input Shaft Rear	*	1
Input Shaft Pilot	*	1
Output Shaft	6412 NR	1
Countershaft Front	*	1
Countershaft Rear	*	1
1st Gear	*	1
2nd Gear	*	1
3rd Gear	*	1

FTRK 19 OB		
Input Shaft	6310 ZNR	1
Input Shaft Pilot	*	1
Output Shaft	6310 NR	1
Countershaft Front	*	1
Countershaft Rear	6309 ZNR	1
Rev. Idler Gear	*	2

POSITION	FERSA	QTY
FTRK 23 OB		
Input Shaft	6211 ZNR	1
Input Shaft Pilot	*	1
Output Shaft	6309 ZNR	1
Countershaft Front	*	1
Countershaft Rear	6308 ZNR	1
Rev. Idler Gear	*	2

FTRK 23B OB		
Input Shaft	6211 ZNR	1
Input Shaft Pilot	*	1
Output Shaft	*	1
Countershaft Front	*	1
Countershaft Rear	6308 ZNR	1
Rev. Idler Gear	*	2

FTRK 25 OB		
Input Shaft	6212 ZNR	1
Input Shaft Pilot	*	1
Output Shaft	6309 ZNR	1
Countershaft Front	*	1
Countershaft Rear	6308 ZNR	1
Rev. Idler Gear	*	2

FTRK 27 OB		
Input Shaft	6211 ZNR	1
Input Shaft Pilot	*	1
Output Shaft	6308 NR	1
Countershaft Front	6207 NR	1
Countershaft Rear	*	1

FTRK 28 OB		
Input Shaft	6213 ZNR	1
Output Shaft	6310 NR	1
Countershaft Front	*	1
Countershaft Rear	6308 ZNR	1
Rev. Idler Gear	*	2

FTRK 29 OB		
Input Shaft	6211 ZNR	1
Input Shaft Pilot	*	1
Output Shaft	6308 NR	1
Countershaft Front	6208 NR	1
Countershaft Rear	*	2
Rev. Idler Front	*	1
Rev. Idler Rear	*	1
Rev. Idler Thrust	*	1

POSITION	FERSA	QTY
FTRK 29B OB		
Input Shaft	6211 ZNR	1
Input Shaft Pilot	*	1
Output Shaft	6309 ZNR	1
Countershaft Front	6208 NR	1
Countershaft Rear	*	2
Rev. Idler Front	*	1
Rev. Idler Rear	*	1
Rev. Idler Thrust	*	1

FTRK 43 OB		
Input Shaft Front	6211	1
Input Shaft Rear	6311 NR	1
Input Shaft Pilot	*	1
Output Shaft	6313 NR	1
Countershaft Front	3578/3525	1
Countershaft Rear	3578/3525	1

FTRK 45 OB		
Input Shaft	6311 ZNR	1
Input Shaft Pilot	*	1
Output Shaft	6311 NR	1
Countershaft Front	*	1
Countershaft Rear	6310 ZNR	1
Rev. Idler Gear	*	2

FTRK 48 OB		
Input Shaft	6212 ZNR	1
Input Shaft Pilot	*	1
Output Shaft	6310 NR	1
Countershaft Front	*	1
Countershaft Rear	6309 ZNR	1
Rev. Idler Gear	*	2

FTRK 52 OB		
Input Shaft	*	1
Input Shaft Pilot	*	1
Output Shaft	6312 NR	1
Countershaft Rear	*	1
Countershaft Front	*	1
Crossover Lever	*	1
Rev. Idler Gear	*	2

FTRK 58 OB		
Input Shaft	6212 ZNR/C3	1
Output Shaft Center	6018 NR	1
Output Shaft Rear	6213	1
Countershaft Front	F 19101	2
Countershaft Rear	*	2
Rev. Idler Gear	F 19095	2

POSITION	FERSA	QTY
FTRK 58A OB		
Input Shaft	6212 ZNR/C3	1
Output Shaft Center	6018 NR	1
Output Shaft Rear	6213	1
Countershaft Front	F 19085	2
Countershaft Rear	*	2
Rev. Idler Gear	F 19095	2

FTRK 65 OB		
Input Shaft	6313 ZNR	1
Input Shaft Pilot	*	1
Mainshaft	496/493	2
Mainshaft Pilot	*	1
Output Shaft	*	1
Countershaft Front	*	1
Countershaft Rear	*	1
Rear Countershaft Front	621/612	1
Rear Countershaft Rear	621/612	1
Rev. Idler Gear	*	2

FTRK 70 OB		
Input Shaft Front	28580/28521	1
Input Shaft Rear	28580/28521	1
Input Shaft Pilot	6209	1
Output Shaft	6310	1
Countershaft Front	3479/3420	1
Countershaft Rear	3479/3420	1

FTRK 72 OB		
Input Shaft	6216 ZNR	1
Output Shaft	6311 NR	1
Countershaft Front	*	1
Countershaft Rear	6310 ZNR	1
Rev. Idler Gear	*	2

FTRK 73 OB		
Input Shaft Front	6210	1
Input Shaft Rear	*	1
Input Shaft Pilot	*	1
Output Shaft	6312 NR	1
Countershaft Front	3877/3820	1
Countershaft Rear	462/453 A	1
Speed Gear	*	1

2.2 \ F-Box Transmission Rebuild Kit

POSITION	FERSA	QTY
FTRK 74 OB		
Input Shaft	6313 Z	1
Input Shaft Pilot	*	1
Mainshaft Front	*	1
Mainshaft Rear	*	1
Output Shaft	6412 NR	1
Countershaft Front	*	1
Countershaft Rear	*	1
Rev. Idler Gear	*	2
1st Gear	*	1
2nd Gear	*	1
3rd Gear	*	1
Aux. Countershaft Front	*	1
Aux. Countershaft Rear	*	1
Aux. 1st Gear	*	1
Aux. 2nd Gear	*	1
Aux. 3rd Gear	*	1

FTRK 82 OB		
Input Shaft	6308 NR	1
Input Shaft Pilot	*	1
Output Shaft	6308 NR	1
Countershaft Front	*	1
Countershaft Rear	*	1
Rev. Idler Gear	*	2
2nd Gear	*	1

FTRK 82D OB		
Driveshaft Rear	*	1
Input Shaft	*	1
Input Shaft Pilot	6308 NR	1
Output Shaft	*	1
Countershaft Rear	*	1
Rev. Idler Gear	*	2

FTRK 82F OB		
Input Shaft	*	1
Input Shaft Pilot	*	1
Output Shaft	6308 NR	1
Countershaft Front	*	1
Countershaft Rear	*	1
Rev. Idler Gear	*	2

FTRK 82FD OB		
Input Shaft	M 802048/M 802011	1
Input Shaft Pilot	*	1
Output Shaft	6308 NR	1
Countershaft Front	*	1
Countershaft Rear	*	1
Rev. Idler Gear	*	2

POSITION	FERSA	QTY
FTRK 86 OB		
Input Shaft Front	6210	1
Input Shaft Rear	6311 NR	1
Input Shaft Pilot	*	1
Output Shaft	6311 NR	1
Countershaft Front	3479/3420	1
Countershaft Rear	3479/3420	1

FTRK 127 OB		
Input Shaft	HM 88649/HM 88610	1
Input Shaft Pilot	*	1
Output Shaft	6308 NR	1
Countershaft Front	*	1
Countershaft Rear	*	1
Countershaft Rear Thrust	*	1
Synchro Hub Thrust (3rd & 4th Gears)	*	1
Rev. Idler Gear	*	1

FTRK 127F OB		
Input Shaft	HM 88649/HM 88610	1
Input Shaft Pilot	*	1
Output Shaft	6308 NR	1
Countershaft Front	*	1
Countershaft Rear	*	1
Countershaft Rear Thrust	*	1
Synchro Hub Thrust (3rd & 4th Gears)	*	1
Rev. Idler Gear	*	1

FTRK 127G OB		
Input Shaft	6308 NR	1
Input Shaft Pilot	*	1
Output Shaft	6308 NR	1
Countershaft Front	*	1
Countershaft Rear	*	1
Countershaft Rear Thrust	*	1
Synchro Hub Thrust (3rd & 4th Gears)	*	1

FTRK 130 OB		
Input Shaft	*	1
Input Shaft Pilot	*	1
Mainshaft Front	*	1
Mainshaft Rear	*	1
Output Shaft	6412 NR	1
Countershaft Front	25590/25520	2
Countershaft Rear	*	1
Rev. Idler Gear	*	2
1st Gear	*	1
2nd Gear	*	1
3rd Gear	*	1
Aux. Countershaft Front	*	1
Aux. Countershaft Rear	*	1
Aux. 1st Gear	*	1
Aux. 2nd Gear	*	1
Aux. 3rd Gear	*	1

POSITION	FERSA	QTY
FTRK 132 OB		
Input Shaft	6213 ZNR	1
Input Shaft Pilot	*	1
Output Shaft	*	1
Countershaft Front	*	1
Countershaft Rear	6310 ZNR	1
Rev. Idler Gear	*	2

FTRK 133 OB		
Input Shaft	*	1
Input Shaft Pilot	*	1
Output Shaft	6311 NR	1
Countershaft Front	*	1
Countershaft Rear	6310 ZNR	1
Rev. Idler Gear	*	2

FTRK 139 OB		
Input Shaft	*	1
Input Shaft Pilot	*	1
Output Shaft	6312 NR	1
Countershaft Front	25590/25520	2
Countershaft Rear	*	1
Rev. Idler Gear	*	2
1st Gear	*	1
2nd Gear	*	1
3rd Gear	*	1

FTRK 140 OB		
Input Shaft	*	1
Input Shaft Pilot	*	1
Output Shaft Front	*	1
Output Shaft Rear	*	1
Countershaft Front	25590/25520	2
Countershaft Rear	*	1
Rev. Idler Gear	*	2
1st Gear	*	1
2nd Gear	*	1
3rd Gear	*	1
4th Gear	*	1

FTRK 141 OB		
Input Shaft	*	1
Input Shaft Pilot	*	1
Output Shaft Front	*	1
Output Shaft Rear	*	1
Countershaft Front	25590/25520	2
Countershaft Rear	*	1
Rev. Idler Gear	*	2
1st Gear	*	1
2nd Gear	*	1
3rd Gear	*	1

POSITION	FERSA	QTY
FTRK 145 OB		
Input Shaft	*	1
Aux. Drive Gear	6017 NR	1
Aux. Mainshaft Front	*	1
Aux. Mainshaft Rear	6212 NR	1
Countershaft Front	*	2
Countershaft Rear	*	2
Aux. Countershaft Front	*	2
Aux. Countershaft Rear	*	2
Rev. Idler Gear	*	2

FTRK 145A OB		
Input Shaft	*	1
Aux. Drive Gear	6017 NR	1
Aux. Mainshaft Front	*	1
Aux. Mainshaft Rear	6212 NR	1
Countershaft Front	*	2
Countershaft Rear	*	2
Aux. Countershaft Front	*	2
Aux. Countershaft Rear	*	2
Rev. Idler Gear	*	2

FTRK 146 OB		
Input Shaft	*	1
Aux. Drive Gear	6017 NR	1
Aux. Mainshaft	*	1
Countershaft Front	*	2
Countershaft Rear	*	2
Aux. Countershaft Front	*	2
Aux. Countershaft Rear	6310 NR	2
Rev. Idler Gear	*	2

FTRK 147 OB		
Input Shaft	*	1
Input Shaft Pilot	*	1
Output Shaft	*	1
Countershaft Front	6311 NR	2
Countershaft Rear	*	2
Rev. Idler Gear	*	4

FTRK 148 OB		
Input Shaft	*	1
Input Shaft Pilot	*	1
Output Shaft	*	1
Countershaft Front	*	1
Countershaft Rear	*	1
Rev. Idler Gear	*	2

2.2 \ F-Box Transmission Rebuild Kit

POSITION	FERSA	QTY
FTRK 149 OB		
Input Shaft	6212 ZNR/C3	1
Aux. Drive Gear	6018 NR	1
Aux. Mainshaft	*	1
Countershaft Front	F 19101	2
Countershaft Rear	*	2
Aux. Countershaft Front	*	2
Aux. Countershaft Rear	*	2
Rev. Idler Gear	F 19095	2
Aux. Range Shaft Quill Front	6204	1

FTRK 149/2 OB		
Input Shaft	6212 ZNR/C3	1
Aux. Drive Gear	6018 NR	1
Aux. Mainshaft	*	1
Countershaft Front	F 19101	2
Countershaft Rear	*	2
Aux. Countershaft Front	*	2
Aux. Countershaft Rear	*	2
Rev. Idler Gear	F 19095	2
Aux. Range Shaft Quill Front	6204	1

FTRK 149AUX OB		
Aux. Mainshaft	*	1
Aux. Countershaft Front	*	2
Aux. Countershaft Rear	*	2
Aux. Range Shaft Quill Front	6204	1

FTRK 149AUX/2 OB		
Aux. Mainshaft	*	1
Aux. Countershaft Front	*	2
Aux. Countershaft Rear	*	2
Aux. Range Shaft Quill Front	6204	1

FTRK 152 OB		
Input Shaft Front	*	1
Input Shaft Rear	*	1
Input Shaft Pilot	*	1
Output Shaft	*	1
Countershaft Front	6311 NR	2
Countershaft Rear	*	2
Rev. Idler Gear	*	4

FTRK 155 OB		
Input Shaft Front	*	1
Input Shaft Rear	*	1
Input Shaft Pilot	*	1
Output Shaft	6412 NR	1
Countershaft Front	*	1
Countershaft Rear	*	1
Mainshaft 1st Gear	*	1
Mainshaft 2nd Gear	*	1
Mainshaft 3rd Gear	*	1

POSITION	FERSA	QTY
FTRK 156 OB		
Input Shaft	*	1
Input Shaft Pilot	*	1
Input Shaft Pilot (T-495/ T-496 M o de ls)	*	1
Output Shaft	6309 ZNR	1
Countershaft Front	*	1
Countershaft Rear	6308 ZNR	1
Rev. Idler Gear	*	2

FTRK 157A OB		
Input Shaft	*	1
Input Shaft Pilot	*	1
Output Shaft	6308 NR	1
Countershaft Front (1978 & Earlier)	*	1
Countershaft Front (1979 & Later)	*	1
Countershaft Rear	6308 NR	1

FTRK 157AWS OB		
Input Shaft	*	1
Input Shaft Pilot	*	1
Output Shaft	6308 NR	1
Countershaft Front (1978 & Earlier)	*	1
Countershaft Front (1979 & Later)	*	1
Countershaft Rear	6308 NR	1

FTRK 157B OB		
Input Shaft	*	1
Input Shaft Pilot	*	1
Output Shaft	6308 NR	1
Countershaft Front (1979 & Later)	*	1
Countershaft Rear	6308 NR	1

FTRK 157BWS OB		
Input Shaft	*	1
Input Shaft Pilot	*	1
Output Shaft	6308 NR	1
Countershaft Front	*	1
Countershaft Rear	6308 NR	1

FTRK 157L OB		
Input Shaft	*	1
Input Shaft Pilot	*	1
Output Shaft	6308 NR	1
Countershaft Front (1979 & Later)	*	1
Countershaft Rear	6308 NR	1

POSITION	FERSA	QTY
FTRK 157LWS OB		
Input Shaft	*	1
Input Shaft Pilot	*	1
Output Shaft	6308 NR	1
Countershaft Front	*	1
Countershaft Rear	6308 NR	1

FTRK 158 OB		
Input Shaft Front	6212	1
Input Shaft Rear	*	1
Input Shaft Pilot	*	1
Output Shaft	*	1
Countershaft Front	*	2
Countershaft Rear	*	2

FTRK 159 OB		
Input Shaft	6212 ZNR/C3	1
Aux. Drive Gear	6018 NR	1
Aux. Mainshaft	*	1
Countershaft Front	F 19101	2
Countershaft Rear	*	2
Aux. Countershaft Front	*	2
Aux. Countershaft Rear	*	2
Rev. Idler Gear	F 19095	2
Range Shaft Quill Front	6204	1

FTRK 159A OB		
Input Shaft	6212 ZNR/C3	1
Aux. Drive Gear	6018 NR	1
Aux. Mainshaft	*	1
Countershaft Front	F 19085	2
Countershaft Rear	*	2
Rev. Idler Gear	F 19095	2
Aux. Countershaft	*	2
Aux. Countershaft Rear	*	2
Range Shaft Quill Front	6204	1

FTRK 160 OB		
Input Shaft	6212 ZNR/C3	1
Aux. Drive Gear	6018 NR	1
Aux. Mainshaft	*	1
Countershaft Front	F 19101	2
Countershaft Rear	*	2
Rev. Idler Gear	F 19095	2
Aux. Countershaft Front	*	2
Aux. Countershaft Rear	6311 NR	2

FTRK 161 OB		
Rear Output Shaft Front	14131/14276	1
Rear Output Shaft Rear	14131/14276	1
Intermediate Gear	*	1
Intermediate Shaft Front	*	1
Intermediate Shaft Rear	*	1
Front Output Shaft Front	6206	1

POSITION	FERSA	QTY
FTRK 166A OB		
Front Output Shaft Front	14116/14276	1
Front Output Shaft Rear	14116/14276	1
Rear Output Shaft Front	25877/25821	1
Rear Output Shaft Rear	15117/15245	1
Intermediate Gear	*	1

FTRK 167 OB		
Input Shaft Front	6309 Z	1
Input Shaft Rear	6307 Z	1
Idler Gear Front	HM 89449/HM 89411	1
Idler Gear Rear	31597/31521	1
Upper Output Shaft Front	25878/25821	1
Upper Output Shaft Rear	25584/25520	1
Lower Output Shaft Front	6208 NR	1
Lower Output Shaft Rear	6211 NR	1

FTRK 174 OB		
Input Shaft	HM 88649/HM 88610	1
Input Shaft Pilot	*	1
Output Shaft	25581/25520	1
Countershaft Front	*	1
Countershaft Rear	*	1
Rev. Idler Gear	*	1
Rev. Idler Thrust	*	1

FTRK 177 OB		
Input Shaft	6213 ZNR	1
Input Shaft Pilot	*	1
Output Shaft	*	1
Countershaft Front	*	1
Countershaft Rear	*	1
Rev. Idler Gear	*	4

FTRK 180 OB		
Input Shaft	JM 511946/JM 511910	1
Input Shaft Pilot	CONE 2580	1
Output Shaft	JM 511946/JM 511910	1
Countershaft Front	25584/25520	1
Countershaft Rear	25584/25520	1
Rev. Idler Gear	*	2
Mainshaft 1st Gear	*	1
Mainshaft 2nd Gear	*	1
Mainshaft Rev. Gear	*	1

FTRK 181 OB		
Input Shaft	*	1
Input Shaft Pilot	*	1
Output Shaft	6312 NR	1
Countershaft Front	6311 NR	2
Countershaft Rear	*	2
Rev. Idler Gear	*	4
Output Shaft Rear	6214 NR	1

2.2 \ F-Box Transmission Rebuild Kit

POSITION	FERSA	QTY
FTRK 182 OB		
Input Shaft Front	6209	1
Front Output Shaft Front	M 86649/M 86610	1
Front Output Shaft Rear	M 86649/M 86610	1
Rear Output Shaft Front	25877/25821	1
Rear Output Shaft Rear	15117/15245	1
Rear Output Shaft Pilot	*	1
Intermediate Shaft	*	48

FTRK 183 OB		
Input Shaft	*	1
Input Shaft Pilot	*	1
Output Shaft	6309 ZNR	1
Countershaft Front	*	1
Countershaft Rear	6308 ZNR	1
Rev. Idler Gear	*	4
1st Gear	*	1
2nd Gear	*	1
Rev. Gear	*	1
1st Gear Thrust	*	1
Rev. Gear Thrust	*	1

FTRK 184 OB		
Input Shaft	6212 ZNR/C3	1
Aux. Drive Gear	6017 NR	1
Aux. Mainshaft	*	1
Countershaft Front	F 19101	2
Rev. Idler Gear	F 19095	2
Countershaft Rear	*	2
Aux. Countershaft Front	*	2
Aux. Countershaft Rear	*	2
Range Shaft Quill Front	6204	1

FTRK 185 OB		
Input Shaft	6214 NR	1
Input Shaft Pilot	*	1
Output Shaft	6214 NR	1
Countershaft Front	6308 NR	3
Countershaft Rear	*	3
Rear Countershaft Rear	6208 NR	2
Rev. Idler Gear	*	3
Shift Rail	*	3

FTRK 186 OB		
Input Shaft	JM 511946/JM 511910	1
Input Shaft Pilot	25877/25821	1
Output Shaft	3979/JM 511910	1
Countershaft Front	M 804049/M 804010	1
Countershaft Rear	JLM 506849/JLM 506810	1
Rev. Idler Gear	*	2
Mainshaft 1st & Rev. Gear	*	2

POSITION	FERSA	QTY
FTRK 187 OB		
Input Shaft	6214 ZNR	1
Input Shaft Pilot	*	1
Output Shaft Pilot	*	1
Output Shaft Front	6214 NR	1
Output Shaft Rear	*	1
Countershaft Front	6308 NR	3
Countershaft Rear	*	3
Rear Countershaft Front	*	3
Rear Countershaft Rear	6208 NR	3
Rev. Idler Gear	*	3
Shift Rail	*	3

FTRK 188 OB		
Input Shaft	6212 ZNR/C3	1
Aux. Drive Gear	6017 NR	1
Aux. Mainshaft	*	1
Countershaft Front	F 19101	2
Countershaft Rear	*	2
Rev. Idler Gear	F 19095	2
Aux. Countershaft Front	*	2
Aux. Countershaft Rear	6311 NR	2

FTRK 189 OB		
Input Shaft	*	1
Input Shaft Pilot	*	1
Mainshaft Rear	6312 NR	1
Aux. Mainshaft Pilot	*	1
Aux. Mainshaft Rear	6214 NR	1
Countershaft Front	*	2
Countershaft Rear	*	2
Rev. Idler Gear	*	4
Output Shaft	*	1
Aux. Countershaft Front	JLM 104948/JLM 104910	2
Aux. Countershaft Rear	JLM 104948/JLM 104910	2

FTRK 190 OB		
Input Shaft	M 802048/M 802011	1
Input Shaft Pilot	*	1
Output Shaft	25584/ 25547 RB	1
Countershaft Front	*	1
Countershaft Rear	*	1
Rev. Idler Gear	*	2
4th & 5th Shift Hub	*	1

POSITION	FERSA	QTY
FTRK 191 OB		
Input Shaft	*	1
Input Shaft Pilot	*	1
Mainshaft Rear	6214 NR	1
Aux. Mainshaft Pilot	*	1
Aux. Mainshaft Rear	6214 NR	1
Countershaft Front	6311 NR	2
Countershaft Rear	*	2
Rev. Idler Gear	*	4
Aux. Countershaft Front	JLM 104948/JLM 104910	2
Aux. Countershaft Rear	JLM 506849/JLM 506810	2

FTRK 192 OB		
Input Shaft	*	1
Input Shaft Pilot	*	1
Output Shaft	6214 NR	1
Countershaft Front	6311 NR	2
Countershaft Rear	*	2
Countershaft Rear (GMC Models)	*	2
Rev. Idler Gear	*	4

FTRK 193 OB		
Input Shaft	*	1
Input Shaft Pilot	*	1
Output Shaft	*	1
Countershaft Front	6311 NR	2
Countershaft Rear	*	2
Countershaft Rear (GMC Models)	*	2
Rev. Idler Gear	*	4

FTRK 194 OB		
Input Shaft	*	1
Input Shaft Pilot	*	1
Mainshaft Rear	6214 NR	1
Aux. Mainshaft Pilot	*	1
Aux. Mainshaft Rear	6214 NR	1
Countershaft Front	*	2
Countershaft Rear	*	2
Countershaft Rear (GMC Models)	*	2
Rev. Idler Gear	*	4
Aux. Countershaft Front	JLM 104948/JLM 104910	2
Aux. Countershaft Rear	JLM 506849/JLM 506810	2

POSITION	FERSA	QTY
FTRK 201 OB		
Input Shaft	6212 ZNR/C3	1
Aux. Drive Gear	6018 NR	1
Aux. Mainshaft	*	1
Countershaft Front	F 19085	2
Countershaft Rear	*	2
Rev. Idler Gear	F 19095	2
Aux. Countershaft Front	*	2
Aux. Countershaft Rear	6311 NR	2

FTRK 202 OB		
Input Shaft	6212 ZNR/C3	1
Aux. Drive Gear	6018 NR	1
Aux. Mainshaft	*	1
Countershaft Front	F 19085	2
Countershaft Rear	*	2
Rev. Idler Gear	F 19095	2
Aux. Countershaft Front	*	2
Aux. Countershaft Rear	*	2
Range Shaft Quill Front	6204	1

FTRK 203 OB		
Input Shaft	6212 ZNR/C3	1
Aux. Drive Gear	6018 NR	1
Aux. Mainshaft	*	1
Countershaft Front	F 19085	2
Countershaft Rear	*	2
Countershaft Rear	*	2
Rev. Idler Gear	F 19095	2
Aux. Countershaft Front	*	2
Aux. Countershaft Rear	6310 NR	2
Range Shaft Quill Front	6204	1

FTRK 204 OB		
Input Shaft	6212 ZNR/C3	1
Output Shaft	*	1
Countershaft Front	F 19085	2
Countershaft Rear	F 19085	2
Countershaft Front	6213	1
Countershaft Rear	6213	1
Rev. Idler Gear	*	4

FTRK 205 OB		
Input Shaft	6212 ZNR/C3	1
Aux. Drive Gear	6018 NR	1
Aux. Mainshaft	*	1
Countershaft Front	F 19085	2
Countershaft Rear	*	2
Rev. Idler Gear	F 19095	2
Aux. Countershaft Front	*	2
Aux. Countershaft Rear	6311 NR	2

2.2 \ F-Box Transmission Rebuild Kit

POSITION	FERSA	QTY
FTRK 206 OB		
Input Shaft	6212 ZNR/C3	1
Aux. Drive Gear	6018 NR	1
Aux. Mainshaft	*	1
Countershaft Front	F 19085	2
Countershaft Rear	*	2
Rev. Idler Gear	F 19095	2
Aux. Countershaft Front	*	2
Aux. Countershaft Rear	*	2
Range Shaft Quill Front	6204	1

FTRK 206/2 OB		
Input Shaft	6212 ZNR/C3	1
Aux. Drive Gear	6018 NR	1
Aux. Mainshaft	*	1
Countershaft Front	F 19085	2
Countershaft Rear	*	2
Rev. Idler Gear	F 19095	2
Aux. Countershaft Front	*	2
Aux. Countershaft Rear	*	2
Range Shaft Quill Front	6204	1

FTRK 207 OB		
Input Shaft	6212 ZNR/C3	1
Aux. Drive Gear	6018 NR	1
Aux. Mainshaft	*	1
Countershaft Front	F 19085	2
Countershaft Rear	*	2
Rev. Idler Gear	F 19095	2
Aux. Countershaft Front	*	2
Aux. Countershaft Rear	*	2
Range Shaft Quill Front	6204	1

FTRK 208 OB		
Input Shaft	M 802048/M 802011	1
Input Shaft Pilot	*	1
Output Shaft	25581/25520	1
Countershaft Front	25877/25821	1
Countershaft Rear	2689/2631	1
Rev. Idler Gear	*	1
Mainshaft 1st & 2nd Gear	*	2
Mainshaft 3rd & Rev. Gear	*	2
Mainshaft 4th Gear	*	1
4th & 5th Shift Hub	*	1

POSITION	FERSA	QTY
FTRK 210 OB		
Input Shaft	*	1
Input Shaft Pilot	*	1
Output Shaft	*	1
Countershaft Front	LM 48548/LM 48510	1
Countershaft Rear	LM 102949/LM 102910	1
Mainshaft 1st and Rev. Gear	*	2
Mainshaft 2nd Gear	*	1
Rev. Idler Gear	*	2

FTRK 213 OB		
Input Shaft	6214 ZNR	1
Input Shaft Pilot	*	1
Main Drive Gear	6214 NR	1
Main Drive Gear Pilot	*	1
Output Shaft Pilot	*	1
Output Shaft Front	6214 NR	1
Output Shaft Rear	*	1
Compound Case Countershaft Front	6308 NR	3
Compound Case Countershaft Rear	6206	3
Countershaft Front	*	3
Countershaft Rear	*	3
Rear Countershaft Front	*	3
Rear Countershaft Rear	6208 NR	3
Rev. Idler Gear	*	3
Shift Rail	*	2

FTRK 213SD OB		
Input Shaft	6214 ZNR	1
Input Shaft Pilot	*	1
Main Drive Gear	6214 NR	1
Main Drive Gear Pilot	*	1
Output Shaft Pilot	*	1
Output Shaft Front	6214 NR	1
Output Shaft Rear	*	1
Compound Case Countershaft Front	*	3
Compound Case Countershaft Rear	6206	3
Countershaft Front	*	3
Countershaft Rear	*	3
Rear Countershaft Front	*	3
Rear Countershaft Rear	*	3
Rev. Idler Gear	*	3
Shift Rail	*	2

POSITION	FERSA	QTY
FTRK 214 OB		
Input Shaft	6214 Z	1
Input Shaft Pilot	*	1
Output Shaft Pilot	*	1
Output Shaft Front	6018 NR	1
Output Shaft Rear	*	1
Countershaft Front	JLM 104948/JLM 104910	3
Countershaft Rear	LM 501349/LM 501310	3
Rear Countershaft Front	LM 501349/LM 501310	3
Rear Countershaft Rear	3780/3720	3
Rev. Idler Gear	*	3
Countershaft Rear	*	1
Shift Rail	*	2

FTRK 214MK OB		
Input Shaft	6214 Z	1
Input Shaft Pilot	*	1
Output Shaft Pilot	*	1
Output Shaft Front	6018 NR	1
Output Shaft Rear	*	1
Countershaft Front	JLM 104948/JLM 104910	3
Countershaft Rear	LM 501349/LM 501310	3
Rear Countershaft Front	LM 501349/M 501310	3
Rear Countershaft Rear	3780/3720	3
Rev. Idler Gear	*	3
Countershaft Rear	*	1
Shift Rail	*	2

FTRK 214MK1 OB		
Input Shaft	6214 Z	1
Input Shaft Pilot	*	1
Output Shaft Pilot	*	1
Output Shaft Front	6018 NR	1
Output Shaft Rear	*	1
Countershaft Front	JLM 104948/JLM 104910	3
Countershaft Rear	LM 501349/LM 501310	3
Rear Countershaft Front	LM 501349/LM 501310	3
Rear Countershaft Rear	3780/3720	3
Rev. Idler Gear	*	3
Countershaft Rear	*	1
Shift Rail	*	2

POSITION	FERSA	QTY
FTRK 219 OB		
Input Shaft	*	1
Input Shaft Pilot	*	1
Output Shaft	*	1
Countershaft Front	LM 48548/LM 48510	1
Countershaft Rear	LM 102949/LM 102910	1
1st Gear	*	1
2nd Gear	*	1
3rd Gear	F 17045 K	2
4th Gear	*	2
Rev. Gear	*	1
Rev. Idler Gear	*	2

FTRK 221 OB		
Input Shaft	*	1
Input Shaft Pilot	*	1
Output Shaft	*	1
Countershaft Front	LM 48548/LM 48510	1
Countershaft Rear	2788 A/2729	1
Rev. Idler Gear	*	2
1st Gear	*	1
2nd Gear	*	2
3rd Gear	*	1
4th Gear	*	1

FTRK 222 OB		
Input Shaft	6213 NR	1
Input Shaft Pilot	*	1
Output Shaft Center	6213 NR	1
Output Shaft Rear	*	1
Countershaft Front	2788 A/2729	1
Countershaft Center	*	1
Countershaft Rear	2788 A/2729	1
Rev. Idler Gear	*	2
1st Gear	*	1
2nd Gear	*	1
3rd Gear	*	1
4th Gear	F 17043 K	1
4th Gear	*	1
4th/5th Shift Hub	*	2
6th Gear	*	2
Rev. Gear	*	1

FTRK 226 OB		
Intermediate Shaft Front	2788/2720	1
Intermediate Shaft Rear	25877/25821	1
Output Shaft	*	2
Rev. Shaft	*	2

2.2 \ F-Box Transmission Rebuild Kit

POSITION	FERSA	QTY
FTRK 390F OB		
Input Shaft	M 802048/M 802011	1
Input Shaft Pilot	*	1
Output Shaft	28580/28527 RB	1
Countershaft Front	*	1
Countershaft Rear	*	1
Rev. Idler Gear	*	1
Mainshaft Gear	*	1
4th & 5th Shift Hub	*	1
Mainshaft 4th Gear	*	1
Mainshaft 2nd, 3rd & Rev. Gear	*	3

FTRK 390G OB		
Input Shaft	M 802048/M 802011	1
Input Shaft Pilot	*	1
Output Shaft	25584/25547 RB	1
Countershaft Front	*	1
Countershaft Rear	*	1
Rev. Idler Gear	*	1
Mainshaft Gear	*	1
4th & 5th Shift Hub	*	1
Mainshaft 4th Gear	*	1
Mainshaft 2nd, 3rd & Rev. Gear	*	3

FTRK 390H OB		
Input Shaft	M 804049/M 804010	1
Input Shaft Pilot	*	1
Output Shaft	28580/28527 RB	1
Countershaft Front	*	1
Countershaft Rear	*	1
Rev. Idler Gear	*	1
Mainshaft Gear	*	1
4th & 5th Shift Hub	*	1
Mainshaft 4th Gear	*	1
Mainshaft 2nd, 3rd & Rev. Gear	*	3

FTRK 395F OB		
Input Shaft	M 802048/M 802011	1
Input Shaft Pilot	*	1
Output Shaft	28580/28527 RB	1
Countershaft Front & Rear	25590/25520	2
4th & 5th Shift Hub	*	1
Mainshaft 1st Gear	*	2
Mainshaft 2nd, 3rd & Rev. Gear	*	3
Mainshaft 4th Gear	*	1
Rev. Idler Gear	*	1

POSITION	FERSA	QTY
FTRK 395G OB		
Input Shaft	M 802048/M 802011	1
Input Shaft Pilot	*	1
Output Shaft	25584/25547 RB	1
Countershaft Front & Rear	25590/25520	2
4th & 5th Shift Hub	*	1
Mainshaft 1st Gear	*	2
Mainshaft 2nd, 3rd & Rev. Gear	*	3
Mainshaft 4th Gear	*	1
Rev. Idler Gear	*	1

FTRK 395H OB		
Input Shaft	M 804049/M 804010	1
Input Shaft Pilot	*	1
Output Shaft	28580/28527 RB	1
Countershaft Front & Rear	25590/25520	2
4th & 5th Shift Hub	*	1
Mainshaft 1st Gear	*	2
Mainshaft 2nd, 3rd & Rev. Gear	*	3
Mainshaft 4th Gear	*	1
Rev. Idler Gear	*	1

FTRK 400 OB		
Input Shaft	6212 Z	1
Input Shaft Rear	*	1
Aux. Mainshaft Front	*	1
Aux. Mainshaft Rear	F 19034	1
Aux. Countershaft Front	*	1
Aux. Countershaft Rear	*	1

FTRK 401 OB		
Input Shaft	*	1
Aux. Drive Gear	6017 NR	1
Aux. Mainshaft Front	*	1
Aux. Mainshaft Rear	*	1
Aux. Countershaft Front	*	2
Aux. Countershaft Rear	6311 NR	2

POSITION	FERSA	QTY
FTRK 500 OB		
Clutch Release	*	1
Input Shaft	6214 ZNR	1
Input Shaft Pilot	*	1
Main Drive Gear	6214 NR	1
Main Drive Gear Pilot	*	1
Output Shaft	6214 NR	1
Compound Case Countershaft Front	6308 NR	3
Compound Case Countershaft Rear	6206	3
Countershaft Front	6308 NR	3
Countershaft Rear	*	3
Rear Countershaft	6208 NR	3
Rev. Idler Gear	*	3
Shift Rail	*	3

FTRK 501 OB		
Input Shaft	6218 NR	1
Input Shaft Pilot	*	1
Output Shaft	6214 NR	1
Countershaft Front	6308 NR	3
Countershaft Rear	*	3
Rear Countershaft Rear	6208 NR	3
Rev. Idler Gear	*	3
Shift Rail	*	2

FTRK 502 OB		
Input Shaft	6218 NR	1
Input Shaft Pilot	*	2
Countershaft Front	6308 NR	3
Countershaft Rear	*	3
Rear Countershaft Front	*	3
Rear Countershaft Rear	6208 NR	3
Rev. Idler Gear	*	3

FTRK 503 OB		
Input Shaft	6214 NR	1
Input Shaft Pilot	*	1
Output Shaft	6213	1
Countershaft Front	JLM 104948/JLM 104910	3
Countershaft Rear	LM 501349/LM 501310	3
Rev. Idler Gear	*	3
Clutch Release Shaft	*	2

POSITION	FERSA	QTY
FTRK 503MK OB		
Input Shaft	6214 NR	1
Input Shaft Pilot	*	1
Output Shaft	6213	1
Countershaft Front	JLM 104948/JLM 104910	3
Countershaft Rear	LM 501349/LM 501310	3
Rev. Idler Gear	*	3
Clutch Release Shaft	*	2

FTRK 504 OB		
Input Shaft Front	H 715341/H 715311	1
Input Shaft Rear	H 715341/H 715311	1
Countershaft Front	H 715341/H 715311	1
Countershaft Rear	H 715341/ H 715311	1
Countershaft High - Low Range	*	4
Front Driveshaft Front	458S/453 X	1
Front Driveshaft Rear	4559/4535	1
Rear Driveshaft Front	6461 A/JH 415610	1
Rear Driveshaft Rear	HM 516449 C/HM 516410	1
Rear Output Shaft Front	570/563	1
Rear Output Shaft Rear	570/563	1
Front Output Shaft Front	JH 307749/JH 307710	1
Front Output Shaft Rear	JH 307749/JH 307710	1

FTRK 505 OB		
Input Shaft	6214 Z	1
Input Shaft Pilot	*	1
Output Shaft Pilot	*	1
Output Shaft Front	6018 NR	1
Output Shaft Rear	*	1
Countershaft Front	JLM 104948/JLM 104910	3
Countershaft Rear	LM 501349/LM 501310	3
Rear Countershaft Front	LM 501349/LM 501310	3
Rear Countershaft Rear	3780/3720	3
Rev. Idler Gear	*	3
Countershaft Rear	*	1
Shift Rail	*	2

FTRK 505MK OB		
Input Shaft	6214 Z	1
Input Shaft Pilot	*	1
Output Shaft Pilot	*	1
Output Shaft Front	6018 NR	1
Output Shaft Rear	*	1
Countershaft Front	JLM 104948/JLM 104910	3
Countershaft Rear	LM 501349/LM 501310	3
Rear Countershaft Front	LM 501349/LM 501310	3
Rear Countershaft Rear	3780/3720	3
Rev. Idler Gear	*	3
Countershaft Rear	*	1
Shift Rail	*	2

2.2 \ F-Box Transmission Rebuild Kit

POSITION	FERSA	QTY
FTRK 506 OB		
Input Shaft	6214 NR	1
Input Shaft Pilot	*	1
Output Shaft Pilot	*	1
Output Shaft Front	6018 NR	1
Output Shaft Rear	*	1
Countershaft Front	JLM 104948/JLM 104910	3
Countershaft Rear	LM 501349/LM 501310	3
Rear Countershaft Front	LM 501349/LM 501310	3
Rear Countershaft Rear	3780/3720	3
Rev. Idler Gear	*	3
Countershaft Rear	*	1
High-Low Hub	*	1
Shift Rail	*	2

FTRK 506MK OB		
Input Shaft	6214 NR	1
Input Shaft Pilot	*	1
Output Shaft Pilot	*	1
Output Shaft Front	6018 NR	1
Output Shaft Rear	*	1
Countershaft Front	JLM 104948/JLM 104910	3
Countershaft Rear	LM 501349/LM 501310	3
Rear Countershaft Front	LM 501349/LM 501310	3
Rear Countershaft Rear	3780/3720	3
Rev. Idler Gear	*	3
Countershaft Rear	*	1
High-Low Hub	*	1
Shift Rail	*	2

FTRK 507 OB		
Input Shaft	6214 NR	1
Input Shaft Pilot	*	1
Output Shaft Pilot	*	1
Output Shaft Front	6018 NR	1
Output Shaft Rear	*	1
Countershaft Front	JLM 104948/JLM 104910	3
Countershaft Rear	LM 501349/LM 501310	3
Rear Countershaft Front	LM 501349/LM 501310	3
Rear Countershaft Rear	3780/3720	3
Rev. Idler Gear	*	3
Countershaft Rear	*	1
High-Low Hub	*	1
Shift Rail	*	2

POSITION	FERSA	QTY
FTRK 507MK OB		
Input Shaft	6214 NR	1
Input Shaft Pilot	*	1
Output Shaft Pilot	*	1
Output Shaft Front	6018 NR	1
Output Shaft Rear	*	1
Countershaft Front	JLM 104948/JLM 104910	3
Countershaft Rear	LM 501349/LM 501310	3
Rear Countershaft Front	LM 501349/LM 501310	3
Rear Countershaft Rear	3780/3720	3
Rev. Idler Gear	*	3
Countershaft Rear	*	1
High-Low Hub	*	1
Shift Rail	*	2

FTRK 510 OB		
Input Shaft	F 15345	1
Constant Gear	F 17094 K	1
Input Shaft Pilot	CONE F 15150 A	1
Output Shaft Front	F 15326	1
Output Shaft Rear	F 18053	1
Countershaft Front Brg	F 15347	1
Countershaft Rear	F 15346	1
1st Gear	F 17092 K	1
2nd Gear	F 17095 K	1
Rev. Gear	F 17095 K	1
Rev. Idler Gear	F 17105 K	2

FTRK 510A OB		
Input Shaft	F 15345	1
Constant Gear	F 17094 K	1
Input Shaft Pilot	CONE F 15150 A	1
Output Shaft Front	F 15326	1
Output Shaft Rear	F 18059	1
Countershaft Front Brg	F 15347	1
Countershaft Rear	F 15346	1
1st Gear	F 17092 K	1
2nd Gear	F 17095 K	1
Rev. Gear	F 17095 K	1
Rev. Idler Gear	F 17105 K	2

FTRK 511 OB		
Input Shaft	F 15326	1
Constant Gear Brg	F 17094 K	1
Input Shaft Pilot	CONE F 15150 A	1
Output Shaft Front	F 15326	1
Output Shaft Rear	F 18053	1
Countershaft Front	F 15348	1
Countershaft Rear	F 15346	1
1st Gear	F 17092 K	1
2nd Gear	F 17095 K	1
Rev. Gear	F 17095 K	1
Rev. Idler Gear	F 17105 K	2

POSITION	FERSA	QTY
FTRK 511A OB		
Input Shaft	F 15326	1
Constant Gear Brg	F 17094 K	1
Input Shaft Pilot	CONE F 15150 A	1
Output Shaft Front	F 15326	1
Output Shaft Rear	F 18059	1
Countershaft Front	F 15348	1
Countershaft Rear	F 15346	1
1st Gear	F 17092 K	1
2nd Gear	F 17095 K	1
Rev. Gear	F 17095 K	1
Rev. Idler Gear	F 17105 K	2

FTRK 700 OB		
Input Shaft	*	1
Countershaft Front	25581/25520	2
Countershaft Rear	25590/25520	2
Aux. Countershaft Front	*	2
Aux. Countershaft Rear	*	2
Aux. Mainshaft	CONE JLM 710949 C	1
Rev. Idler Gear	*	2
Low Range	*	2

FTRK 702 OB		
Input Shaft	*	1
Input Shaft Pilot	*	1
Output Shaft	*	1
Countershaft Front	6311 NR	2
Countershaft Rear	*	2
Rev. Idler Gear	*	2

FTRK 703 OB		
Input Shaft Front	6014	1
Input Shaft Rear	*	1
Input Shaft Pilot	*	1
Output Shaft	*	1
Countershaft Front	*	2
Countershaft Rear	*	2

FTRK 704 OB		
Input Shaft	6213 NR	1
Input Shaft Pilot	*	1
Output Shaft	*	1
Countershaft Front	2788 A/2729	1
Countershaft Rear	2788 A/2729	1
1st Gear	*	1
2nd Gear	*	1
3rd Gear	*	1
4th Gear	*	1
Rev. Gear	*	1
Rev. Idler Gear	*	2

POSITION	FERSA	QTY
FTRK 705 OB		
Input Shaft	*	1
Input Shaft Pilot	*	1
Mainshaft Rear	*	1
Output Shaft Front	*	1
Output Shaft Rear	*	1
Countershaft Front	6311 NR	2
Countershaft Rear	*	2
Aux. Countershaft Front	JLM 104948/JLM 104910	2
Aux. Countershaft Rear	JLM 506849/JLM 506810	2
Rev. Idler Gear	*	4
Range Gear	*	1

FTRK 706 OB		
Input Shaft Front	*	1
Input Shaft Pilot	*	1
Output Shaft	*	1
Countershaft Front	*	2
Countershaft Rear	*	2
Rev. Idler Gear	*	4

FTRK 707 OB		
Intermediate Shaft Front	2788/2720	1
Intermediate Shaft Rear	25877/25821	1
Output Shaft	23691/23620	2
Rev. Shaft	26883/26824	2

FTRK 708 OB		
Intermediate Shaft Front	*	1
Intermediate Shaft Rear	*	1
Output Shaft	23691/23620	2
Rev. Shaft	26883/26824	2

FTRK 709 OB		
Intermediate Shaft Front	*	1
Intermediate Shaft Rear	*	1
Output Shaft	*	2
Rev. Shaft	*	2

FTRK 1000 OB		
Input Shaft	6212 ZNR/C3	1
Aux. Drive Gear	6017 NR	1
Aux. Mainshaft	*	1
Countershaft Front	F 19101	2
Countershaft Rear	*	2
Aux. Countershaft Front	*	2
Aux. Countershaft Rear	6310 NR	2
Rev. Idler Gear	F 19095	2
Aux. Range Shaft Quill Front	6204	1

2.2 \ F-Box Transmission Rebuild Kit

POSITION	FERSA	QTY
FTRK 1000AUX OB		
Aux. Mainshaft	*	1
Aux. Countershaft Front	*	2
Aux. Countershaft Rear	6310 NR	2
Aux. Range Shaft Quill Front	6204	1

FTRK 1063 OB		
Input Shaft	6212 ZNR/C3	1
Aux. Drive Gear	*	1
Aux. Mainshaft	*	1
Countershaft Front	F 19101	2
Countershaft Rear	*	2
Rev. Idler Gear	F 19095	2
Aux. Countershaft Front	*	2
Aux. Countershaft Rear	6310 NR	2

FTRK 1064 OB		
Input Shaft	6212 ZNR/C3	1
Aux. Drive Gear	*	1
Aux. Mainshaft	*	1
Countershaft Front	F 19101	2
Countershaft Rear	*	2
Rev. Idler Gear	F 19095	2
Aux. Countershaft Front	*	2
Aux. Countershaft Rear	6311 NR	2

FTRK 1079 OB		
Input Shaft	F 19088	1
Aux. Drive Gear	*	1
Aux. Mainshaft	*	1
Countershaft Front	F 19085	2
Countershaft Rear	*	2
Rev. Idler Gear	F 19095	2
Aux. Countershaft Front	*	2
Aux. Countershaft Rear	*	2
Aux. Range Shaft Quill Front	6204	1

FTRK 1554 OB		
Aux. Mainshaft	*	1
Aux. Countershaft Front	*	2
Aux. Countershaft Rear	*	2
Aux. Range Shaft Quill Front	6204	1

FTRK 1555 OB		
Aux. Mainshaft	*	1
Aux. Countershaft Front	*	2
Aux. Countershaft Rear	6310 NR	2
Aux. Range Shaft Quill Front	6204	1

POSITION	FERSA	QTY
FTRK 1763 OB		
Input Shaft	F 19088	1
Aux. Drive Gear	*	1
Aux. Mainshaft	*	1
Aux. Mainshaft Front	F 19085	1
Aux. Mainshaft Rear	*	1
Rev. Idler Gear	F 19095	2
Aux. Countershaft Front	*	2
Aux. Countershaft Rear	*	2
Aux. Range Shaft Quill Front	6204	1

FTRK 1765 OB		
Input Shaft	6212 ZNR/C3	1
Output Shaft	6212 NR	1
Countershaft Front	6309 NR	2
Countershaft Rear	6309 NR	2
Aux. Countershaft	*	2
Rev. Idler Gear	*	4

FTRK 1766 OB		
Input Shaft	*	1
Input Shaft Pilot	*	1
Output Shaft	*	1
Countershaft Front	*	1
Countershaft Rear	*	1
1st, 2nd, 3rd & Rev. Gear	*	4
4th Gear	*	1
5th Gear	*	1
Rev. Idler Gear	*	2

FTRK 1850 OB		
Input Shaft	*	1
Aux. Drive Gear	6017 NR	1
Aux. Mainshaft Front	*	1
Aux. Mainshaft Rear	6212 NR	1
Countershaft Front	*	2
Countershaft Rear	*	2
Rev. Idler Gear	*	2
Aux. Countershaft Front	*	2
Aux. Countershaft Rear	*	2

FTRK 1851 OB		
Input Shaft	*	1
Aux. Drive Gear	6017 NR	1
Aux. Mainshaft	*	1
Countershaft Front	*	2
Countershaft Rear	*	2
Rev. Idler Gear	*	2
Aux. Countershaft Front	*	2
Aux. Countershaft Rear	6310 NR	2

POSITION	FERSA	QTY
FTRK 1852 OB		
Input Shaft	6212 ZNR/C3	1
Output Shaft Front	*	1
Output Shaft Rear	6213	1
Countershaft Front	F 19101	2
Countershaft Rear	*	2
Rev. Idler Gear	F 19095	2

FTRK 1855 OB		
Input Shaft	6212 ZNR/C3	1
Aux. Drive Gear	6017 NR	1
Aux. Mainshaft	*	1
Countershaft Front	F 19101	2
Countershaft Rear	*	2
Rev. Idler Gear	F 19095	2
Aux. Countershaft Front	*	2
Aux. Countershaft Rear	6310 NR	2
Aux. Range Shaft Quill Front	6204	1

FTRK 1857 OB		
Input Shaft	6212 ZNR/C3	1
Output Shaft	*	1
Countershaft Front	F 19101	2
Countershaft Rear	*	2
Rev. Idler Gear	F 19095	2

FTRK 1858 OB		
Input Shaft	6212 ZNR/C3	1
Aux. Drive Gear	*	1
Aux. Mainshaft	*	1
Countershaft Front	F 19101	2
Countershaft Rear	*	2
Rev. Idler Gear	F 19095	2
Aux. Countershaft Front	*	2
Aux. Countershaft Rear	6310 NR	2

FTRK 1859 OB		
Input Shaft	6212 ZNR/C3	1
Aux. Drive Gear	6017 NR	1
Aux. Mainshaft	*	1
Countershaft Front	F 19101	2
Countershaft Rear	*	2
Rev. Idler Gear	F 19095	2
Aux. Countershaft Front	*	2
Aux. Countershaft Rear	6311 NR	2

POSITION	FERSA	QTY
FTRK 1860 OB		
Input Shaft	6212 ZNR/C3	1
Aux. Drive Gear	6017 NR	1
Aux. Mainshaft	*	1
Countershaft Front	F 19101	2
Countershaft Rear	*	2
Rev. Idler Gear	F 19095	2
Aux. Countershaft Front	*	2
Aux. Countershaft Rear	*	2
Aux. Range Shaft Quill Front	6204	1

FTRK 1861 OB		
Input Shaft	6212 ZNR/C3	1
Aux. Drive Gear	*	1
Aux. Mainshaft	*	1
Countershaft Front	F 19101	2
Countershaft Rear	*	2
Rev. Idler Gear	F 19095	2
Aux. Countershaft Front	*	2
Aux. Countershaft Rear	6311 NR	2

FTRK 1862 OB		
Input Shaft	6212 ZNR/C3	1
Aux. Drive Gear	*	1
Aux. Mainshaft	*	1
Countershaft Front	F 19101	2
Countershaft Rear	*	2
Rev. Idler Gear	F 19095	2
Aux. Countershaft Front	*	2
Aux. Countershaft Rear	*	2
Aux. Range Shaft Quill Front	6204	1

FTRK 1863 OB		
Input Shaft	F 19088	1
Aux. Drive Gear	*	1
Aux. Mainshaft	*	1
Countershaft Front	F 19085	2
Countershaft Rear	*	2
Rev. Idler Gear	F 19095	2
Aux. Countershaft Front	*	2
Aux. Countershaft Rear	*	2
Aux. Range Shaft Quill Front	6204	1

FTRK 1864 OB		
Input Shaft	6212 ZNR/C3	1
Output Shaft	*	1
Countershaft Front	6309 NR	2
Countershaft Rear	*	2
Rev. Idler Gear	F 19095	2

2.2 \ F-Box Transmission Rebuild Kit

POSITION	FERSA	QTY
FTRK 1866 OB		
Input Shaft	6212 ZNR/C3	1
Aux. Drive Gear	*	1
Aux. Mainshaft	*	1
Countershaft Front	6309 NR	2
Countershaft Rear	*	2
Rev. Idler Gear	F 19095	2
Aux. Countershaft Front	*	2
Aux. Countershaft Rear	6311 NR	2

FTRK 1867 OB		
Input Shaft	6212 ZNR/C3	1
Aux. Drive Gear	*	1
Aux. Mainshaft	*	1
Countershaft Front	6309 NR	2
Countershaft Rear	*	2
Rev. Idler Gear	F 19095	2
Aux. Countershaft Front	*	2
Aux. Countershaft Rear	*	2
Aux. Range Shaft Quill Front	6204	1

FTRK 1870 OB		
Input Shaft	6212 ZNR/C3	1
Aux. Drive Gear	*	1
Aux. Mainshaft	*	1
Countershaft Front	F 19085	2
Countershaft Rear	*	2
Rev. Idler Gear	F 19095	2
Aux. Countershaft Front	*	2
Aux. Countershaft Rear	6311 NR	2

FTRK 1871 OB		
Input Shaft	6212 ZNR/C3	1
Aux. Drive Gear	*	1
Aux. Mainshaft	*	1
Countershaft Front	F 19085	2
Countershaft Rear	*	2
Rev. Idler Gear	F 19095	2
Aux. Countershaft Front	*	2
Aux. Countershaft Rear	*	2
Aux. Range Shaft Quill Front	6204	1

FTRK 1872 OB		
Input Shaft	F 19088	1
Aux. Drive Gear	*	1
Aux. Mainshaft	*	1
Countershaft Front	F 19085	2
Countershaft Rear	*	2
Rev. Idler Gear	F 19095	2
Aux. Countershaft Front	*	2
Aux. Countershaft Rear	*	2
Aux. Range Shaft Quill Front	6204	1

POSITION	FERSA	QTY
FTRK 1873 OB		
Input Shaft	6212 ZNR/C3	1
Output Shaft Front	*	1
Output Shaft Rear	6213	1
Countershaft Front	6309 NR	2
Countershaft Rear	*	2
Rev. Idler Gear	F 19095	2

FTRK 1874 OB		
Input Shaft	6212 ZNR/C3	1
Aux. Drive Gear	*	1
Aux. Mainshaft	*	1
Countershaft Front	F 19085	2
Countershaft Rear	*	2
Rev. Idler Gear	F 19095	2
Aux. Countershaft Front	*	2
Aux. Countershaft Rear	*	2
Aux. Range Shaft Quill Front	6204	1

FTRK 1875 OB		
Input Shaft	F 19088	1
Aux. Drive Gear	*	1
Aux. Mainshaft	*	1
Aux. Mainshaft Front	F 19085	1
Aux. Mainshaft Rear	*	1
Rev. Idler Gear	F 19095	2
Aux. Countershaft Front	*	2
Aux. Countershaft Rear	*	2
Aux. Range Shaft Quill Front	6204	1

FTRK 1876 OB		
Input Shaft	*	1
Aux. Drive Gear	6017 NR	1
Aux. Mainshaft Front	*	1
Aux. Mainshaft Rear	6212 ZNR/C3	1
Rev. Idler Gear	*	2
Countershaft Front	*	2
Countershaft Rear	*	2
Aux. Countershaft Front	*	2
Aux. Countershaft Rear	F 19034	2

FTRK 1877 OB		
Input Shaft	6212 ZNR/C3	1
Output Shaft	6212 NR	1
Countershaft Front	6309 NR	2
Countershaft Rear	6309 NR	2
Aux. Countershaft	*	2
Rev. Idler Gear	*	4

POSITION	FERSA	QTY
FTRK 1971 OB		
Input Shaft	6212 ZNR/C3	1
Aux. Drive Gear	*	1
Aux. Mainshaft	*	1
Countershaft Front	F 19085	2
Countershaft Rear	*	2
Rev. Idler Gear	F 19095	2
Aux. Countershaft Front	*	2
Aux. Countershaft Rear	6311 NR	2
Front Cover	*	1

FTRK 1972 OB		
Input Shaft	6212 ZNR/C3	1
Aux. Drive Gear	*	1
Aux. Mainshaft	*	1
Countershaft Front	F 19085	2
Countershaft Rear	*	2
Rev. Idler Gear	F 19095	2
Aux. Countershaft Front	*	2
Aux. Countershaft Rear	*	2
Aux. Range Shaft Quill Front	6204	1
Front Cover	*	1

FTRK 1979 OB		
Input Shaft	F 19088	1
Aux. Drive Gear	*	1
Aux. Mainshaft	*	1
Countershaft Front	F 19085	2
Countershaft Rear	*	2
Rev. Idler Gear	F 19095	2
Aux. Countershaft Front	*	2
Aux. Countershaft Rear	*	2
Aux. Range Shaft Quill Front	6204	1

FTRK 1980 OB		
Input Shaft	6212 ZNR/C3	1
Aux. Drive Gear	*	1
Aux. Mainshaft	*	1
Countershaft Front	6309 NR	2
Countershaft Rear	*	2
Rev. Idler Gear	F 19095	2
Aux. Countershaft Front	*	2
Aux. Countershaft Rear	6311 NR	2
Front Cover	*	1

POSITION	FERSA	QTY
FTRK 1981 OB		
Input Shaft	6212 ZNR/C3	1
Aux. Drive Gear	*	1
Aux. Mainshaft	*	1
Countershaft Front	6309 NR	2
Countershaft Rear	*	2
Rev. Idler Gear	F 19095	2
Aux. Countershaft Front	*	2
Aux. Countershaft Rear	*	2
Aux. Range Shaft Quill Front	6204	1
Front Cover	*	1

FTRK 1982 OB		
Input Shaft	6212 ZNR/C3	1
Output Shaft	*	1
Countershaft Front	6309 NR	2
Countershaft Rear	6309 NR	2
Aux. Countershaft	*	2
Rev. Idler Gear	*	4
Front Cover	*	1

FTRK 1984 OB		
Input Shaft	6212 ZNR/C3	1
Output Shaft Front	*	1
Output Shaft Rear	6213	1
Countershaft Front	6309 NR	2
Countershaft Rear	*	2
Rev. Idler Gear	F 19095	2
Front Cover	*	1

FTRK 1986 OB		
Input Shaft	6212 ZNR/C3	1
Aux. Drive Gear	*	1
Aux. Mainshaft	*	1
Countershaft Front	6309 NR	2
Countershaft Rear	*	2
Rev. Idler Gear	F 19095	2
Aux. Countershaft Front	F 15112	2
Aux. Countershaft Rear	F 15112	2

FTRK 1991 OB		
Input Shaft	F 19088	1
Aux. Drive Gear	*	1
Aux. Mainshaft	*	1
Countershaft Front	F 19085	2
Countershaft Rear	*	2
Rev. Idler Gear	F 19095	2
Aux. Countershaft Front	F 15112	2
Aux. Countershaft Rear	F 15112	2

2.2 \ F-Box Transmission Rebuild Kit

POSITION	FERSA	QTY
FTRK 1992 OB		
Input Shaft	F 19088	1
Aux. Drive Gear	*	1
Aux. Mainshaft	*	1
Countershaft Front	F 19085	2
Countershaft Rear	*	2
Rev. Idler Gear	F 19095	2
Aux. Countershaft Front	F 15112	2
Aux. Countershaft Rear	F 15112	2

FTRK 1993 OB		
Aux. Mainshaft	*	1
Aux. Countershaft Front	*	2
Aux. Countershaft Rear	*	2

FTRK 1995 OB		
Input Shaft	*	1
Aux. Drive Gear	6017 NR	1
Aux. Mainshaft	*	1
Countershaft Front	*	2
Countershaft Rear	*	2
Rev. Idler Gear	*	2
Aux. Countershaft Front	*	2
Aux. Countershaft Rear	6310 NR	2
Range Shaft Quill Front	6204	1

FTRK 1996 OB		
Input Shaft	6212 ZNR/C3	1
Aux. Drive Gear	*	1
Aux. Mainshaft	*	1
Countershaft Front	F 19085	2
Countershaft Rear	*	2
Rev. Idler Gear	F 19095	2
Aux. Countershaft Front	F 15112	2
Aux. Countershaft Rear	F 15112	2

FTRK 1999 OB		
Input Shaft	6212 ZNR/C3	1
Aux. Drive Gear	*	1
Aux. Mainshaft	*	1
Countershaft Front	F 19085	2
Countershaft Rear	*	2
Rev. Idler Gear	F 19095	2
Aux. Countershaft Front	F 15112	2
Aux. Countershaft Rear	F 15112	2

POSITION	FERSA	QTY
FTRK 2041 OB		
Input Shaft	39590/39520	1
Mainshaft Pilot	CONE 31594	1
Output Shaft	45284/45220	1
Countershaft Front	25590/25522	1
Countershaft Rear	3782/3720	1
1st, 2nd & Rev. Gear	F 17044 K	6
3rd Gear	F 17043 K	2
4th Gear	F 17046 K	2
5th Gear	F 17045 K	2
Rev. Idler Gear	F 17106 K	2

FTRK 2043 OB		
Input Shaft	F 19088	1
Aux. Drive Gear	*	1
Aux. Mainshaft	*	1
Countershaft Front	F 19085	2
Countershaft Rear	*	2
Rev. Idler Gear	F 19095	2
Aux. Countershaft Front	F 15112	2
Aux. Countershaft Rear	F 15112	2

FTRK 2045 OB		
Input Shaft	6212 ZNR/C3	1
Aux. Drive Gear	*	1
Aux. Mainshaft	*	1
Countershaft Front	6309 NR	2
Countershaft Rear	*	2
Rev. Idler Gear	F 19095	2
Aux. Countershaft Front	F 15112	2
Aux. Countershaft Rear	F 15112	2

FTRK 2047 OB		
Input Shaft	*	1
Aux. Drive Gear	6017 NR	1
Aux. Mainshaft	*	1
Countershaft Front	*	2
Countershaft Rear	*	2
Rev. Idler Gear	*	2
Aux. Countershaft Front	*	2
Aux. Countershaft Rear	6310 NR	2
Range Shaft Quill Front	6204	1

FTRK 2048 OB		
Input Shaft	*	1
Mainshaft Rear	6017 NR	1
Aux. Mainshaft Pilot	*	1
Aux. Mainshaft Rear	F 19088	1
Countershaft Front	*	2
Countershaft Rear	*	2
Rev. Idler Gear	*	2
Aux. Countershaft Front	*	2
Aux. Countershaft Rear	*	2

POSITION	FERSA	QTY
FTRK 2049 OB		
Input Shaft	6212 ZNR/C3	1
Aux. Drive Gear	*	1
Aux. Mainshaft	*	1
Countershaft Front	F 19085	2
Countershaft Rear	*	2
Rev. Idler Gear	F 19095	2
Aux. Countershaft Front	F 15112	2
Aux. Countershaft Rear	F 15112	2

FTRK 2120 OB		
Input Shaft	M 802048/M 802011	1
Input Shaft Pilot	*	1
Output Shaft	25581/25520	1
Countershaft Front	25877/25821	1
Countershaft Rear	2689/2631	1
Rev. Idler Gear	*	1
Mainshaft 1st & 2nd Gear	*	2
Mainshaft 3rd & Rev. Gear	*	2
Mainshaft 4th Gear	*	1
4th & 5th Shift Hub	*	1

FTRK 2121 OB		
Input Shaft	M 802048/M 802011	1
Input Shaft Pilot	*	1
Output Shaft	28580 A/28527 RB	1
Countershaft Front & Rear	25590/25520	2
4th & 5th Shift Hub	*	1
Mainshaft 1st Gear	*	2
Mainshaft 2nd, 3rd & Rev. Gear	*	3
Mainshaft 4th Gear	*	1
Rev. Idler Gear	*	1

FTRK 2122 OB		
Input Shaft	M 802048/M 802011	1
Input Shaft Pilot	*	1
Output Shaft	25584/25547 RB	1
Countershaft Front & Rear	25590/25520	2
4th & 5th Shift Hub	*	1
Mainshaft 1st Gear	*	2
Mainshaft 2nd, 3rd & Rev. Gear	*	3
Mainshaft 4th Gear	*	1
Rev. Idler Gear	*	1

POSITION	FERSA	QTY
FTRK 2123 OB		
Input Shaft	M 804049/M 804010	1
Input Shaft Pilot	*	1
Output Shaft	28580 A/28527 RB	1
Countershaft Front & Rear	25590/25520	2
4th & 5th Shift Hub	*	1
Mainshaft 1st Gear	*	2
Mainshaft 2nd, 3rd & Rev. Gear	*	3
Mainshaft 4th Gear	*	1
Rev. Idler Gear	*	1

FTRK 2124 OB		
Input Shaft	M 802048/M 802011	1
Input Shaft Pilot	*	1
Output Shaft	28580 A/28527 RB	1
Countershaft Front	*	1
Countershaft Rear	*	1
Rev. Idler Gear	*	1
Mainshaft Gear	*	2
4th & 5th Shift Hub	*	1
Mainshaft 2nd, 3rd & Rev. Gear	*	3
Mainshaft 4th Gear	*	1

FTRK 2125 OB		
Input Shaft	M 804049/M 804010	1
Input Shaft Pilot	*	1
Output Shaft	28580 A/28527 RB	1
Countershaft Front	*	1
Countershaft Rear	*	1
Rev. Idler Gear	*	1
Mainshaft Gear	*	2
4th & 5th Shift Hub	*	1
Mainshaft 2nd, 3rd & Rev. Gear	*	3
Mainshaft 4th Gear	*	1

FTRK 2126 OB		
Input Shaft	M 802048/M 802011	1
Input Shaft Pilot	*	1
Output Shaft	25584/25547 RB	1
Countershaft Front	*	1
Countershaft Rear	*	1
Rev. Idler Gear	*	1
Mainshaft Gear	*	2
4th & 5th Shift Hub	*	1
Mainshaft 2nd, 3rd & Rev. Gear	*	3
Mainshaft 4th Gear	*	1

2.2 \ F-Box Transmission Rebuild Kit

POSITION	FERSA	QTY
FTRK 2127 OB		
Input Shaft	*	1
Input Shaft Pilot	*	1
Output Shaft	*	1
Countershaft Front	*	1
Countershaft Rear	*	1
Rev. Idler Gear	*	2

FTRK 2128 OB		
Input Shaft	M 802048/M 802011	1
Input Shaft Pilot	*	1
Output Shaft	25584/25547 RB	1
Countershaft Front	*	1
Countershaft Rear	*	1
Rev. Idler Gear	*	2
4th & 5th Shift Hub	*	1

FTRK 2129 OB		
Input Shaft	M 804049/M 804010	1
Input Shaft Pilot	*	1
Output Shaft	25581/25520	1
Countershaft Front	25877/25821	1
Countershaft Rear	2689/2631	1
4th & 5th Shift Hub	*	1
Rev. Idler Gear	*	1
Mainshaft 1st & 2nd Gear	*	2
Mainshaft 3rd & Rev. Gear	*	2
Mainshaft 4th Gear	*	1

FTRK 2130 OB		
Input Shaft	39590/39520	1
Input Shaft Pilot	CONE 31594	1
Output Shaft	45284/45220	1
Countershaft Front	25590/25522	1
Countershaft Rear	3782/3720	1
1st, 2nd, 3rd & Rev. Gear	*	4
4th Gear	*	1
5th Gear	*	1
Rev. Idler Gear	*	2

FTRK 2131 OB		
Input Shaft	39590/39520	1
Input Shaft Pilot	CONE 31594	1
Output Shaft	45284/45220	1
Countershaft Front	25590/25522	1
Countershaft Rear	3782/3720	1
1st & Rev. Gear	F 17044 K	4
2nd Gear	F 17043 K	2
3rd Gear	F 17046 K	2
4th Gear	F 17045 K	2
Rev. Idler Gear	F 17106 K	2

POSITION	FERSA	QTY
FTRK 2275 OB		
Input Shaft	6212 ZNR/C3	1
Aux. Drive Gear	*	1
Aux. Mainshaft	*	1
Countershaft Front	F 19085	2
Countershaft Rear	*	2
Rev. Idler Gear	F 19095	2
Aux. Countershaft Front	F 15112	2
Aux. Countershaft Rear	F 15112	2

FTRK 2277 OB		
Input Shaft	6212 ZNR/C3	1
Aux. Drive Gear	*	1
Aux. Mainshaft	*	1
Countershaft Front	F 19085	2
Countershaft Rear	*	2
Rev. Idler Gear	F 19095	2
Aux. Countershaft Front	F 15112	2
Aux. Countershaft Rear	F 15112	2

FTRK 2280 OB		
Input Shaft	6212 ZNR/C3	1
Aux. Drive Gear	*	1
Aux. Mainshaft	*	1
Countershaft Front	F 19085	2
Countershaft Rear	*	2
Rev. Idler Gear	F 19095	2
Range Shaft Quill Front	6204	1
Aux. Countershaft Front	F 15112	2
Aux. Countershaft Rear	F 15112	2

FTRK 2281 OB		
Input Shaft	6212 ZNR/C3	1
Aux. Drive Gear	6018 NR	1
Aux. Mainshaft	*	1
Countershaft Front	F 19085	2
Countershaft Rear	*	2
Rev. Idler Gear	F 19095	2
Range Shaft Quill Front	6204	1
Aux. Countershaft Front	F 15112	2
Aux. Countershaft Rear	F 15112	2

FTRK 2282 OB		
Input Shaft	6212 ZNR/C3	1
Aux. Drive Gear	*	1
Aux. Mainshaft	*	1
Countershaft Front	F 19085	2
Countershaft Rear	*	2
Rev. Idler Gear	F 19095	2
Aux. Countershaft Front	*	2
Aux. Countershaft Rear	*	2

POSITION	FERSA	QTY
FTRK 2283 OB		
Input Shaft	6212 ZNR/C3	1
Aux. Drive Gear	*	1
Aux. Mainshaft	*	1
Countershaft Front	F 19085	2
Countershaft Rear	*	2
Rev. Idler Gear	F 19095	2
Range Shaft Quill Front	6204	1
Aux. Countershaft Front	*	2
Aux. Countershaft Rear	6310 NR	2

FTRK 2284 OB		
Input Shaft	6212 ZNR/C3	1
Aux. Drive Gear	*	1
Aux. Mainshaft	*	1
Countershaft Front	F 19085	2
Countershaft Rear	*	2
Rev. Idler Gear	F 19095	2
Aux. Countershaft Front	F 15112	2
Aux. Countershaft Rear	F 15112	2

FTRK 2285 OB		
Input Shaft	6212 ZNR/C3	1
Aux. Drive Gear	F 18036	1
Aux. Mainshaft	*	1
Countershaft Front	F 19085	2
Countershaft Rear	*	2
Rev. Idler Gear	F 19095	2
Aux. Countershaft Front	F 15112	2
Aux. Countershaft Rear	F 15112	2

FTRK 2286 OB		
Input Shaft	6212 ZNR/C3	1
Aux. Drive Gear	F 18036	1
Aux. Mainshaft	*	1
Countershaft Front	F 19085	2
Countershaft Rear	*	2
Rev. Idler Gear	F 19095	2
Aux. Countershaft Front	F 15112	2
Aux. Countershaft Rear	F 15112	2

FTRK 2287 OB		
Input Shaft	6212 ZNR/C3	1
Aux. Drive Gear	F 18036	1
Aux. Mainshaft	*	1
Countershaft Front	F 19085	2
Countershaft Rear	*	2
Rev. Idler Gear	F 19095	2
Aux. Countershaft Front	F 15109	2
Aux. Countershaft Rear	F 15109	2

POSITION	FERSA	QTY
FTRK 2288 OB		
Input Shaft	6212 ZNR/C3	1
Aux. Drive Gear	F 18036	1
Aux. Mainshaft	*	1
Splitter Gear	F 15295	1
Countershaft Front	F 19085	2
Countershaft Rear	*	2
Rev. Idler Gear	F 19095	2
Aux. Countershaft Front	F 15109	2
Aux. Countershaft Rear	F 15109	2

FTRK 2335 OB		
Input Shaft	6212 ZNR/C3	1
Aux. Drive Gear	*	1
Aux. Mainshaft	*	1
Countershaft Front	F 19085	2
Countershaft Rear	*	2
Rev. Idler Gear	F 19095	2
Aux. Countershaft Front	F 15112	2
Aux. Countershaft Rear	F 15112	2

FTRK 2336 OB		
Input Shaft	6212 ZNR/C3	1
Aux. Drive Gear	*	1
Aux. Mainshaft	*	1
Countershaft Front	F 19085	2
Countershaft Rear	*	2
Rev. Idler Gear	F 19095	2
Aux. Countershaft Front	F 15112	2
Aux. Countershaft Rear	F 15112	2

FTRK 2338 OB		
Aux. Mainshaft	*	1
Aux. Countershaft Front	F 15112	2
Aux. Countershaft Rear	F 15112	2

FTRK 2340 OB		
Aux. Mainshaft	*	1
Aux. Countershaft Front	F 15112	2
Aux. Countershaft Rear	F 15112	2
Aux. Range Shaft Quill Front	6204	1

FTRK 2341 OB		
Input Shaft	6212 ZNR/C3	1
Aux. Drive Gear	*	1
Aux. Mainshaft	*	1
Countershaft Front	F 19085	2
Countershaft Rear	*	2
Rev. Idler Gear	F 19095	2
Range Shaft Quill Front	6204	1
Aux. Countershaft Front	F 15112	2
Aux. Countershaft Rear	F 15112	2

2.2 \ F-Box Transmission Rebuild Kit

POSITION	FERSA	QTY
FTRK 2342 OB		
Input Shaft	6212 ZNR/C3	1
Aux. Drive Gear	6018 NR	1
Aux. Mainshaft	*	1
Countershaft Front	F 19085	2
Countershaft Rear	*	2
Rev. Idler Gear	F 19095	2
Range Shaft Quill Front	6204	1
Aux. Countershaft Front	F 15112	2
Aux. Countershaft Rear	F 15112	2

FTRK 2343 OB		
Input Shaft	6212 ZNR/C3	1
Aux. Drive Gear	*	1
Aux. Mainshaft	*	1
Countershaft Front	F 19085	2
Countershaft Rear	*	2
Rev. Idler Gear	F 19095	2
Aux. Countershaft Front	*	2
Aux. Countershaft Rear	*	2

FTRK 2344 OB		
Input Shaft	6212 ZNR/C3	1
Aux. Drive Gear	*	1
Aux. Mainshaft	*	1
Countershaft Front	F 19085	2
Countershaft Rear	*	2
Rev. Idler Gear	F 19095	2
Aux. Countershaft Front	*	2
Aux. Countershaft Rear	*	2

FTRK 2345 OB		
Input Shaft	6212 ZNR/C3	1
Aux. Drive Gear	*	1
Aux. Mainshaft	*	1
Countershaft Front	F 19085	2
Countershaft Rear	*	2
Rev. Idler Gear	F 19095	2
Range Shaft Quill Front	6204	1
Aux. Countershaft Front	*	2
Aux. Countershaft Rear	6310 NR	2
Front Cover	*	1

FTRK 2464 OB		
Input Shaft	39590/39520	1
Input Shaft Pilot	CONE 31594	1
Output Shaft	39585/39520	1
Countershaft Front	25590/25522	1
Countershaft Rear	3782/3720	1
1st, 2nd, 3rd & Rev. Gear	*	4
4th Gear	*	1
5th Gear	F 17045 K	2
Rev. Idler Gear	*	2

POSITION	FERSA	QTY
FTRK 2468 OB		
Clutch Pilot	6306 2RS	1
Input Shaft	6212 ZNR/C3	1
Front Cover	*	1

FTRK 2490 OB		
Input Shaft	39590/39520	1
Input Shaft Pilot	CONE 31594	1
Output Shaft	39585/39520	1
Countershaft Front	25590/25522	1
Countershaft Rear	3782/3720	1
1st, 2nd, 3rd & Rev. Gear	*	4
4th Gear	*	1
5th Gear	*	1
Rev. Idler Gear	*	2

FTRK 2758 OB		
Input Shaft	6212 ZNR/C3	1
Aux. Drive Gear	F 18036	1
Aux. Mainshaft	*	1
Countershaft Front	F 19085	2
Countershaft Rear	*	2
Rev. Idler Gear	F 19095	2
Aux. Countershaft Front	F 15112	2
Aux. Countershaft Rear	F 15112	2

FTRK 2759 OB		
Aux. Mainshaft	*	1
Aux. Countershaft Front	F 15112	2
Aux. Countershaft Rear	F 15112	2

FTRK 2761 OB		
Input Shaft	6212 ZNR/C3	1
Aux. Drive Gear	*	1
Aux. Mainshaft	*	1
Countershaft Front	F 19085	2
Countershaft Rear	*	2
Rev. Idler Gear	F 19095	2
Range Shaft Quill Front	6204	1
Aux. Countershaft Front	*	2
Aux. Countershaft Rear	6310 NR	2
Front Cover	*	1

FTRK 2762 OB		
Input Shaft	6212 ZNR/C3	1
Aux. Drive Gear	*	1
Aux. Mainshaft	*	1
Countershaft Front	F 19085	2
Countershaft Rear	*	2
Rev. Idler Gear	F 19095	2
Aux. Countershaft Front	F 15112	2
Aux. Countershaft Rear	F 15112	2

POSITION	FERSA	QTY
FTRK 2763 OB		
Input Shaft	6212 ZNR/C3	1
Aux. Drive Gear	*	1
Aux. Mainshaft	*	1
Countershaft Front	F 19085	2
Countershaft Rear	*	2
Rev. Idler Gear	F 19095	2
Aux. Countershaft Front	F 15112	2
Aux. Countershaft Rear	F 15112	2

FTRK 2764 OB		
Input Shaft	6212 ZNR/C3	1
Aux. Drive Gear	*	1
Aux. Mainshaft	*	1
Aux. Mainshaft Thrust	*	2
Countershaft Front	F 19085	2
Countershaft Rear	*	2
Rev. Idler Gear	F 19095	2
Aux. Countershaft Front	F 15112	2
Aux. Countershaft Rear	F 15112	2

FTRK 2765 OB		
Input Shaft	6212 ZNR/C3	1
Aux. Drive Gear	*	1
Aux. Mainshaft	*	1
Aux. Mainshaft Thrust	*	2
Countershaft Front	F 19085	2
Countershaft Rear	*	2
Rev. Idler Gear	F 19095	2
Aux. Countershaft	F 15112	4

FTRK 2767 OB		
Input Shaft	6212 ZNR/C3	1
Aux. Drive Gear	F 18036	1
Aux. Mainshaft	*	1
Countershaft Front	F 19085	2
Countershaft Rear	*	2
Rev. Idler Gear	F 19095	2
Aux. Countershaft Front	F 15112	2
Aux. Countershaft Rear	F 15112	2

FTRK 2768 OB		
Aux. Mainshaft	*	1
Aux. Countershaft Front	F 15112	2
Aux. Countershaft Rear	F 15112	2

FTRK 2769 OB		
Aux. Mainshaft	*	1
Aux. Countershaft Front	*	2
Aux. Countershaft Rear	*	2

POSITION	FERSA	QTY
FTRK 2770 OB		
Input Shaft	6212 ZNR/C3	1
Aux. Drive Gear	F 18036	1
Aux. Mainshaft	*	1
Countershaft Front	F 19085	2
Countershaft Rear	*	2
Rev. Idler Gear	F 19095	2
Aux. Countershaft Front	F 15109	2
Aux. Countershaft Rear	F 15109	2

FTRK 2771 OB		
Input Shaft	6212 ZNR/C3	1
Output Shaft	*	1
Countershaft Front	6309 NR	2
Countershaft Rear	6309 NR	2
Aux. Countershaft	*	2
Rev. Idler Gear	*	4

FTRK 2772 OB		
Input Shaft	6212 ZNR/C3	1
Aux. Drive Gear	*	1
Aux. Mainshaft	*	1
Aux. Mainshaft Thrust	*	2
Countershaft Front	F 19085	2
Countershaft Rear	*	2
Rev. Idler Gear	F 19095	2
Aux. Countershaft Front	F 15112	2
Aux. Countershaft Rear	F 15112	2

FTRK 2773 OB		
Input Shaft	6212 ZNR/C3	1
Aux. Drive Gear	*	1
Aux. Mainshaft	*	1
Aux. Mainshaft Thrust	*	2
Countershaft Front	F 19085	2
Countershaft Rear	*	2
Rev. Idler Gear	F 19095	2
Aux. Countershaft	F 15112	4

FTRK 2779 OB		
Input Shaft	6212 ZNR/C3	1
Aux. Drive Gear	F 18036	1
Aux. Mainshaft	*	1
Splitter Gear	F 15295	1
Countershaft Front	F 19085	2
Countershaft Rear	*	2
Rev. Idler Gear	F 19095	2
Aux. Countershaft Front	F 15109	2
Aux. Countershaft Rear	F 15109	2

2.2 \ F-Box Transmission Rebuild Kit

POSITION	FERSA	QTY
FTRK 2780 OB		
Input Shaft	6212 ZNR/C3	1
Aux. Drive Gear	6017 NR	1
Aux. Mainshaft	*	1
Countershaft Front	F 19101	2
Countershaft Rear	*	2
Rev. Idler Gear	F 19095	2
Aux. Countershaft Front	*	2
Aux. Countershaft Rear	6310 NR	2
Aux. Range Shaft Quill Front	6204	1

FTRK 2847 OB		
Input Shaft	6212 ZNR/C3	1
Aux. Drive Gear	*	1
Aux. Mainshaft	*	1
Countershaft Front	F 19085	2
Countershaft Rear	*	2
Rev. Idler Gear	F 19095	2
Aux. Countershaft Front	F 15112	2
Aux. Countershaft Rear	F 15112	2

FTRK 2848 OB		
Input Shaft	6212 ZNR/C3	1
Aux. Drive Gear	*	1
Aux. Mainshaft	*	1
Countershaft Front	F 19085	2
Countershaft Rear	*	2
Rev. Idler Gear	F 19095	2
Aux. Countershaft Front	F 15112	2
Aux. Countershaft Rear	F 15112	2

FTRK 2855 OB		
Input Shaft	6212 ZNR/C3	1
Aux. Drive Gear	*	1
Aux. Mainshaft	*	1
Countershaft Front	6309 NR	2
Countershaft Rear	*	2
Rev. Idler Gear	F 19095	2
Aux. Countershaft Front	F 15112	2
Aux. Countershaft Rear	F 15112	2

FTRK 2865 OB		
Input Shaft	6212 ZNR/C3	1
Aux. Drive Gear	F 18036	1
Aux. Mainshaft	*	1
Splitter Gear	F 15295	1
Countershaft Front	F 19085	2
Countershaft Rear	F 19067	2
Rev. Idler Gear	F 19095	2
Aux. Countershaft Front	F 15109	2
Aux. Countershaft Rear	F 15109	2

POSITION	FERSA	QTY
FTRK 2866 OB		
Input Shaft	6212 ZNR/C3	1
Aux. Drive Gear	F 18036	1
Aux. Mainshaft	*	1
Splitter Gear	F 15295	1
Countershaft Front	F 19085	2
Countershaft Rear	F 19067	2
Rev. Idler Gear	F 19095	2
Aux. Countershaft Front	F 15109	2
Aux. Countershaft Rear	F 15109	2

FTRK 2924 OB		
Input Shaft	F 19088	1
Aux. Drive Gear	*	1
Aux. Mainshaft	F 15330	1
Countershaft Front	F 19094	2
Countershaft Rear	F 19094	2
Rev. Idler Gear	F 19095	2
Aux. Countershaft Front	F 15112	2
Aux. Countershaft Rear	F 15112	2

FTRK 2993 OB		
Input Shaft	6212 ZNR/C3	1
Aux. Drive Gear	*	1
Aux. Mainshaft	*	1
Aux. Mainshaft Thrust	*	2
Countershaft Front	F 19085	2
Countershaft Rear	*	2
Rev. Idler Gear	F 19095	2
Aux. Countershaft Front	F 15112	2
Aux. Countershaft Rear	F 15112	2

FTRK 2994 OB		
Input Shaft	6212 ZNR/C3	1
Aux. Drive Gear	*	1
Aux. Mainshaft	*	1
Aux. Mainshaft Thrust	*	2
Countershaft Front	F 19085	2
Countershaft Rear	*	2
Rev. Idler Gear	F 19095	2
Aux. Countershaft Front	*	2
Aux. Countershaft Rear	*	2

FTRK 2996 OB		
Input Shaft	6212 ZNR/C3	1
Aux. Drive Gear	*	1
Aux. Mainshaft	*	1
Aux. Mainshaft Thrust	*	2
Countershaft Front	F 19085	2
Countershaft Rear	*	2
Rev. Idler Gear	F 19095	2
Aux. Countershaft Front	F 15112	2
Aux. Countershaft Rear	F 15112	2

POSITION	FERSA	QTY
FTRK 2997 OB		
Input Shaft	6212 ZNR/C3	1
Aux. Drive Gear	*	1
Aux. Mainshaft	*	1
Aux. Mainshaft Thrust	*	2
Countershaft Front	F 19085	2
Countershaft Rear	*	2
Rev. Idler Gear	F 19095	2
Aux. Countershaft Front	*	2
Aux. Countershaft Rear	*	2

FTRK 2998 OB		
Input Shaft	6212 ZNR/C3	1
Aux. Drive Gear	*	1
Aux. Mainshaft	*	1
Aux. Mainshaft Thrust	*	2
Countershaft Front	F 19085	2
Countershaft Rear	*	2
Rev. Idler Gear	F 19095	2
Aux. Countershaft Front	*	2
Aux. Countershaft Rear	*	2

FTRK 3132 OB		
Input Shaft	F 19088	1
Aux. Drive Gear	*	1
Aux. Mainshaft	F 15330	1
Countershaft Front	F 19094	2
Countershaft Rear	F 19094	2
Rev. Idler Gear	F 19095	2
Aux. Countershaft Front	F 15112	2
Aux. Countershaft Rear	F 15112	2

FTRK 3233 OB		
Input Shaft	F 19088	1
Aux. Drive Gear	F 18036	1
Aux. Mainshaft	F 15330	1
Countershaft Front	F 19085	2
Countershaft Rear	*	2
Rev. Idler Gear	F 19095	2
Aux. Countershaft Front	F 15112	2
Aux. Countershaft Rear	F 15112	2

FTRK 3234 OB		
Input Shaft	F 19088	1
Aux. Drive Gear	F 18036	1
Aux. Mainshaft	F 15330	1
Countershaft Front	F 19085	2
Countershaft Rear	*	2
Rev. Idler Gear	F 19095	2
Aux. Countershaft Front	F 15112	2
Aux. Countershaft Rear	F 15112	2

POSITION	FERSA	QTY
FTRK 3256 OB		
Input Shaft	F 19088	1
Aux. Drive Gear	*	1
Aux. Mainshaft	F 15330	1
Countershaft Front	F 19085	2
Countershaft Rear	*	2
Rev. Idler Gear	F 19095	2
Aux. Countershaft Front	F 15112	2
Aux. Countershaft Rear	F 15112	2

FTRK 3257 OB		
Input Shaft	F 19088	1
Aux. Drive Gear	*	1
Aux. Mainshaft	F 15330	1
Countershaft Front	F 19085	2
Countershaft Rear	*	2
Rev. Idler Gear	F 19095	2
Aux. Countershaft Front	F 15112	2
Aux. Countershaft Rear	F 15112	2

FTRK 3258 OB		
Input Shaft	F 19088	1
Aux. Drive Gear	*	1
Aux. Mainshaft	F 15330	1
Countershaft Front	F 19085	2
Countershaft Rear	*	2
Rev. Idler Gear	F 19095	2
Aux. Countershaft Front	F 15112	2
Aux. Countershaft Rear	F 15112	2

FTRK 3272 OB		
Input Shaft	F 19088	1
Aux. Drive Gear	*	1
Aux. Mainshaft	F 15330	1
Countershaft Front	F 19085	2
Countershaft Rear	*	2
Rev. Idler Gear	F 19095	2
Aux. Countershaft Front	F 15112	2
Aux. Countershaft Rear	F 15112	2

FTRK 3273 OB		
Input Shaft	F 19088	1
Aux. Drive Gear	*	1
Aux. Mainshaft	F 15330	1
Countershaft Front	F 19085	2
Countershaft Rear	*	2
Rev. Idler Gear	F 19095	2
Aux. Countershaft Front	F 15112	2
Aux. Countershaft Rear	F 15112	2

2.2 \ F-Box Transmission Rebuild Kit

POSITION	FERSA	QTY
FTRK 3282 OB		
Input Shaft	F 19088	1
Aux. Drive Gear	*	1
Aux. Mainshaft	F 15330	1
Countershaft Front	F 19085	2
Countershaft Rear	*	2
Rev. Idler Gear	F 19095	2
Aux. Countershaft Front	F 15112	2
Aux. Countershaft Rear	F 15112	2

FTRK 3283 OB		
Input Shaft	F 19088	1
Aux. Drive Gear	*	1
Aux. Mainshaft	F 15330	1
Countershaft Front	F 19085	2
Countershaft Rear	*	2
Rev. Idler Gear	F 19095	2
Aux. Countershaft Front	F 15112	2
Aux. Countershaft Rear	F 15112	2

FTRK 3286 OB		
Input Shaft	6212 ZNR/C3	1
Aux. Drive Gear	F 18036	1
Aux. Mainshaft	F 15330	1
Splitter Gear	F 15295	1
Countershaft Front	F 19085	2
Countershaft Rear	*	2
Rev. Idler Gear	F 19095	2
Aux. Countershaft Front	F 15112	2
Aux. Countershaft Rear	F 15112	2

FTRK 3287 OB		
Input Shaft	6212 ZNR/C3	1
Aux. Drive Gear	F 18036	1
Aux. Mainshaft	F 15330	1
Splitter Gear	F 15295	1
Countershaft Front	F 19085	2
Countershaft Rear	*	2
Rev. Idler Gear	F 19095	2
Aux. Countershaft Front	F 15112	2
Aux. Countershaft Rear	F 15112	2

FTRK 3322 OB		
Input Shaft	F 19088	1
Aux. Drive Gear	*	1
Aux. Mainshaft	*	1
Countershaft Front	F 19085	2
Countershaft Rear	*	2
Rev. Idler Gear	F 19095	2
Aux. Countershaft Front	F 15112	2
Aux. Countershaft Rear	F 15112	2

POSITION	FERSA	QTY
FTRK 3323 OB		
Input Shaft	F 19088	1
Aux. Drive Gear	*	1
Aux. Mainshaft	*	1
Countershaft Front	F 19085	2
Countershaft Rear	*	2
Rev. Idler Gear	F 19095	2
Aux. Countershaft Front	F 15112	2
Aux. Countershaft Rear	F 15112	2

FTRK 3339 OB		
Input Shaft	6212 ZNR/C3	1
Aux. Drive Gear	F 18037	1
Aux. Mainshaft	F 15330	1
Splitter Gear	F 15295	1
Countershaft Front	F 19085	2
Countershaft Rear	F 19067	2
Rev. Idler Gear	F 19095	2
Aux. Countershaft Front	F 15109	2
Aux. Countershaft Rear	F 15109	2

FTRK 3340 OB		
Input Shaft	6212 ZNR/C3	1
Aux. Drive Gear	F 18037	1
Aux. Mainshaft	F 15330	1
Splitter Gear	F 15295	1
Countershaft Front	F 19085	2
Countershaft Rear	F 19067	2
Rev. Idler Gear	F 19095	2
Aux. Countershaft Front	F 15109	2
Aux. Countershaft Rear	F 15109	2

FTRK 3342 OB		
Input Shaft	6212 ZNR/C3	1
Aux. Drive Gear	F 18036	1
Aux. Mainshaft	F 15330	1
Countershaft Front	F 19085	2
Countershaft Rear	F 19067	2
Rev. Idler Gear	F 19095	2
Aux. Countershaft Front	F 15112	2
Aux. Countershaft Rear	F 15112	2

FTRK 3343 OB		
Input Shaft	6212 ZNR/C3	1
Aux. Drive Gear	F 18036	1
Aux. Mainshaft	F 15330	1
Countershaft Front	F 19085	2
Countershaft Rear	F 19067	2
Rev. Idler Gear	F 19095	2
Aux. Countershaft Front	F 15112	2
Aux. Countershaft Rear	F 15112	2

POSITION	FERSA	QTY
FTRK 3344 OB		
Aux. Mainshaft	*	1
Aux. Countershaft Front	F 15112	2
Aux. Countershaft Rear	F 15112	2

FTRK 3345 OB		
Input Shaft	6212 ZNR/C3	1
Aux. Drive Gear	F 18036	1
Aux. Mainshaft	*	1
Countershaft Front	F 19085	2
Countershaft Rear	*	2
Rev. Idler Gear	F 19095	2
Aux. Countershaft Front	F 15112	2
Aux. Countershaft Rear	F 15112	2

FTRK 3346 OB		
Input Shaft	6212 ZNR/C3	1
Aux. Drive Gear	F 18036	1
Aux. Mainshaft	*	1
Countershaft Front	F 19085	2
Countershaft Rear	*	2
Rev. Idler Gear	F 19095	2
Aux. Countershaft Front	F 15112	2
Aux. Countershaft Rear	F 15112	2

FTRK 3347 OB		
Input Shaft	6212 ZNR/C3	1
Aux. Drive Gear	F 18036	1
Aux. Mainshaft	F 15330	1
Countershaft Front	F 19085	2
Countershaft Rear	*	2
Rev. Idler Gear	F 19095	2
Aux. Countershaft Front	F 15112	2
Aux. Countershaft Rear	F 15112	2

FTRK 3348 OB		
Input Shaft	6212 ZNR/C3	1
Aux. Drive Gear	F 18036	1
Aux. Mainshaft	F 15330	1
Countershaft Front	F 19085	2
Countershaft Rear	*	2
Rev. Idler Gear	F 19095	2
Aux. Countershaft Front	F 15112	2
Aux. Countershaft Rear	F 15112	2

FTRK 3350 OB		
Input Shaft	6212 ZNR/C3	1
Aux. Drive Gear	F 18036	1
Aux. Mainshaft	F 15330	1
Countershaft Front	F 19085	2
Countershaft Rear	*	2
Rev. Idler Gear	F 19095	2
Aux. Countershaft Front	F 15112	2
Aux. Countershaft Rear	F 15112	2

POSITION	FERSA	QTY
FTRK 3351 OB		
Input Shaft	6212 ZNR/C3	1
Aux. Drive Gear	F 18036	1
Aux. Mainshaft	F 15330	1
Countershaft Front	F 19085	2
Countershaft Rear	*	2
Rev. Idler Gear	F 19095	2
Aux. Countershaft Front	F 15112	2
Aux. Countershaft Rear	F 15112	2

FTRK 3354 OB		
Input Shaft	6212 ZNR/C3	1
Aux. Drive Gear	F 18036	1
Aux. Mainshaft	F 15330	1
Splitter Gear	F 15295	1
Countershaft Front	F 19085	2
Countershaft Rear	*	2
Rev. Idler Gear	F 19095	2
Aux. Countershaft Front	F 15109	2
Aux. Countershaft Rear	F 15109	2

FTRK 3355 OB		
Input Shaft	6212 ZNR/C3	1
Aux. Drive Gear	F 18036	1
Aux. Mainshaft	F 15330	1
Splitter Gear	F 15295	1
Countershaft Front	F 19085	2
Countershaft Rear	*	2
Rev. Idler Gear	F 19095	2
Aux. Countershaft Front	F 15109	2
Aux. Countershaft Rear	F 15109	2

FTRK 3413 OB		
Input Shaft	F 19088	1
Aux. Drive Gear	F 18036	1
Aux. Mainshaft	F 15330	1
Countershaft Front	F 19085	2
Countershaft Rear	*	2
Rev. Idler Gear	F 19095	2
Aux. Countershaft Front	F 15112	2
Aux. Countershaft Rear	F 15112	2

FTRK 3414 OB		
Input Shaft	F 19088	1
Aux. Drive Gear	F 18036	1
Aux. Mainshaft	F 15330	1
Countershaft Front	F 19085	2
Countershaft Rear	*	2
Rev. Idler Gear	F 19095	2
Aux. Countershaft Front	F 15112	2
Aux. Countershaft Rear	F 15112	2

2.2 \ F-Box Transmission Rebuild Kit

POSITION	FERSA	QTY
FTRK 3423 OB		
Input Shaft	39590/39520	1
Input Shaft Pilot	CONE 31594	1
Output Shaft	45285 A/45220	1
Mainshaft 6th Gear	F 17045 K	2
Mainshaft 4th Gear	F 17046 K	2
Mainshaft 3rd Gear	F 17043 K	2
Mainshaft 2nd Gear	F 17044 K	2
Mainshaft 1st Gear	F 17044 K	2
Mainshaft Rev. Gear	*	1
Countershaft Front	25590/25522	1
Countershaft Rear	3782/3720	1
Rev. Idler Gear	F 17106 K	2

FTRK 3425 OB		
Input Shaft	6212 ZNR/C3	1
Aux. Drive Gear	F 18036	1
Aux. Mainshaft	*	1
Splitter Gear	F 15295	1
Countershaft Front	F 19085	2
Countershaft Rear	F 19067	2
Rev. Idler Gear	F 19095	2
Aux. Countershaft Front	F 15112	2
Aux. Countershaft Rear	F 15112	2

FTRK 3426 OB		
Input Shaft	6212 ZNR/C3	1
Aux. Drive Gear	F 18036	1
Aux. Mainshaft	*	1
Splitter Gear	F 15295	1
Countershaft Front	F 19085	2
Countershaft Rear	F 19067	2
Rev. Idler Gear	F 19095	2
Aux. Countershaft Front	F 15112	2
Aux. Countershaft Rear	F 15112	2

FTRK 3440 OB		
Input Shaft	39590/39520	1
Input Shaft Pilot	CONE 31594	1
Output Shaft	45285 A/45220	1
Countershaft Front	25590/25522	1
Countershaft Rear	3782/3720	1
1st Gear	F 17044 K	2
2nd Gear	F 17044 K	2
3rd Gear	F 17043 K	2
4th Gear	F 17046 K	2
5th Gear	F 17045 K	2
Rev. Gear	F 17046 K	2
Rev. Idler Gear	F 17106 K	2

POSITION	FERSA	QTY
FTRK 3459 OB		
Input Shaft	6212 ZNR/C3	1
Aux. Drive Gear	F 18037	1
Aux. Mainshaft	F 15330	1
Countershaft Front	F 19085	2
Countershaft Rear	F 19067	2
Rev. Idler Gear	F 19095	2
Aux. Countershaft Front	F 15109	2
Aux. Countershaft Rear	F 15109	2

FTRK 3460 OB		
Input Shaft	6212 ZNR/C3	1
Aux. Drive Gear	F 18037	1
Aux. Mainshaft	F 15330	1
Countershaft Front	F 19085	2
Countershaft Rear	F 19067	2
Rev. Idler Gear	F 19095	2
Aux. Countershaft Front	F 15109	2
Aux. Countershaft Rear	F 15109	2

FTRK 3461 OB		
Input Shaft	F 19088	1
Aux. Drive Gear	F 18037	1
Aux. Mainshaft	F 15330	1
Splitter Gear	F 15295	1
Countershaft Front	F 19085	2
Countershaft Rear	F 19067	2
Rev. Idler Gear	F 19095	2
Aux. Countershaft Front	F 15109	2
Aux. Countershaft Rear	F 15109	2

FTRK 3462 OB		
Input Shaft	F 19088	1
Aux. Drive Gear	F 18037	1
Aux. Mainshaft	F 15330	1
Splitter Gear	F 15295	1
Countershaft Front	F 19085	2
Countershaft Rear	F 19067	2
Rev. Idler Gear	F 19095	2
Aux. Countershaft Front	F 15109	2
Aux. Countershaft Rear	F 15109	2

FTRK 3486 OB		
Input Shaft	6212 ZNR/C3	1
Aux. Drive Gear	*	1
Aux. Mainshaft	*	1
Countershaft Front	F 19085	2
Countershaft Rear	*	2
Rev. Idler Gear	F 19095	2
Aux. Countershaft Front	F 15112	2
Aux. Countershaft Rear	F 15112	2

POSITION	FERSA	QTY
FTRK 3487 OB		
Input Shaft	6212 ZNR/C3	1
Aux. Drive Gear	*	1
Aux. Mainshaft	*	1
Countershaft Front	F 19085	2
Countershaft Rear	*	2
Rev. Idler Gear	F 19095	2
Aux. Countershaft Front	F 15112	2
Aux. Countershaft Rear	F 15112	2

FTRK 3488 OB		
Input Shaft	6212 ZNR/C3	1
Aux. Drive Gear	*	1
Aux. Mainshaft	*	1
Countershaft Front	F 19085	2
Countershaft Rear	*	2
Rev. Idler Gear	F 19095	2
Aux. Countershaft Front	F 15112	2
Aux. Countershaft Rear	F 15112	2

FTRK 3512 OB		
Input Shaft	6212 ZNR/C3	1
Aux. Drive Gear	F 18037	1
Aux. Mainshaft	F 15330	1
Splitter Gear	F 15295	1
Countershaft Front	F 19085	2
Countershaft Rear	F 19067	2
Rev. Idler Gear	F 19095	2
Aux. Countershaft Front	F 15109	2
Aux. Countershaft Rear	F 15109	2

FTRK 3513 OB		
Input Shaft	6212 ZNR/C3	1
Aux. Drive Gear	F 18037	1
Aux. Mainshaft	F 15330	1
Splitter Gear	F 15295	1
Countershaft Front	F 19085	2
Countershaft Rear	F 19067	2
Rev. Idler Gear	F 19095	2
Aux. Countershaft Front	F 15109	2
Aux. Countershaft Rear	F 15109	2

FTRK 3514 OB		
Input Shaft	F 19088	1
Aux. Drive Gear	F 18037	1
Aux. Mainshaft	F 15330	1
Splitter Gear	F 15295	1
Countershaft Front	F 19085	2
Countershaft Rear	F 19067	2
Rev. Idler Gear	F 19095	2
Aux. Countershaft Front	F 15109	2
Aux. Countershaft Rear	F 15109	2

POSITION	FERSA	QTY
FTRK 3515 OB		
Input Shaft	F 19088	1
Aux. Drive Gear	F 18037	1
Aux. Mainshaft	F 15330	1
Splitter Gear	F 15295	1
Countershaft Front	F 19085	2
Countershaft Rear	F 19067	2
Rev. Idler Gear	F 19095	2
Aux. Countershaft Front	F 15109	2
Aux. Countershaft Rear	F 15109	2

FTRK 3519 OB		
Input Shaft	6212 ZNR/C3	1
Aux. Drive Gear	*	1
Aux. Mainshaft	F 15330	1
Countershaft Front	F 19085	2
Countershaft Rear	*	2
Rev. Idler Gear	F 19095	2
Aux. Countershaft	F 15112	4

FTRK 3522 OB		
Input Shaft	6212 ZNR/C3	1
Aux. Drive Gear	*	1
Aux. Mainshaft	F 15330	1
Countershaft Front	F 19085	2
Countershaft Rear	*	2
Rev. Idler Gear	F 19095	2
Aux. Countershaft	F 15112	4

FTRK 3524 OB		
Input Shaft	6212 ZNR/C3	1
Aux. Drive Gear	*	1
Aux. Mainshaft	F 15330	1
Countershaft Front	F 19085	2
Countershaft Rear	*	2
Rev. Idler Gear	F 19095	2
Aux. Countershaft	F 15112	4

FTRK 3533 OB		
Input Shaft	6212 ZNR/C3	1
Aux. Drive Gear	F 18037	1
Aux. Mainshaft	F 15330	1
Splitter Gear	F 15295	1
Countershaft Front	F 19085	2
Countershaft Rear	F 19067	2
Rev. Idler Gear	F 19095	2
Aux. Countershaft Front	F 15112	2
Aux. Countershaft Rear	F 15112	2

* Availability to be advised

2.2 \ F-Box Transmission Rebuild Kit

POSITION	FERSA	QTY
FTRK 3534 OB		
Input Shaft	6212 ZNR/C3	1
Aux. Drive Gear	F 18037	1
Aux. Mainshaft	F 15330	1
Splitter Gear	F 15295	1
Countershaft Front	F 19085	2
Countershaft Rear	F 19067	2
Rev. Idler Gear	F 19095	2
Aux. Countershaft Front	F 15112	2
Aux. Countershaft Rear	F 15112	2

FTRK 3553 OB		
Input Shaft	6212 ZNR/C3	1
Aux. Drive Gear	*	1
Aux. Mainshaft	*	1
Splitter Gear	F 15295	1
Countershaft Front	F 19085	2
Countershaft Rear	*	2
Rev. Idler Gear	F 19095	2
Aux. Countershaft Front	F 15112	2
Aux. Countershaft Rear	F 15112	2

FTRK 3554 OB		
Input Shaft	6212 ZNR/C3	1
Aux. Drive Gear	*	1
Aux. Mainshaft	*	1
Splitter Gear	F 15295	1
Countershaft Front	F 19085	2
Countershaft Rear	*	2
Rev. Idler Gear	F 19095	2
Aux. Countershaft Front	F 15112	2
Aux. Countershaft Rear	F 15112	2

FTRK 3585 OB		
Input Shaft	6212 ZNR/C3	1
Aux. Drive Gear	*	1
Aux. Mainshaft	*	1
Aux. Mainshaft Thrust	*	2
Countershaft Front	F 19085	2
Countershaft Rear	*	2
Rev. Idler Gear	F 19095	2
Aux. Countershaft Front	F 15112	2
Aux. Countershaft Rear	F 15112	2

FTRK 3586 OB		
Input Shaft	6212 ZNR/C3	1
Aux. Drive Gear	*	1
Aux. Mainshaft	*	1
Aux. Mainshaft Thrust	*	2
Countershaft Front	F 19085	2
Countershaft Rear	*	2
Rev. Idler Gear	F 19095	2
Aux. Countershaft Front	F 15112	2
Aux. Countershaft Rear	F 15112	2

POSITION	FERSA	QTY
FTRK 3595 OB		
Input Shaft	6212 ZNR/C3	1
Aux. Drive Gear	F 18036	1
Aux. Mainshaft	*	1
Splitter Gear	F 15295	1
Countershaft Front	F 19085	2
Countershaft Rear	*	2
Rev. Idler Gear	F 19095	2
Aux. Countershaft Front	F 15112	2
Aux. Countershaft Rear	F 15112	2

FTRK 3596 OB		
Input Shaft	6212 ZNR/C3	1
Aux. Drive Gear	F 18036	1
Aux. Mainshaft	*	1
Splitter Gear	F 15295	1
Countershaft Front	F 19085	2
Countershaft Rear	*	2
Rev. Idler Gear	F 19095	2
Aux. Countershaft Front	F 15112	2
Aux. Countershaft Rear	F 15112	2

FTRK 3597 OB		
Input Shaft	6212 ZNR/C3	1
Aux. Drive Gear	F 18036	1
Aux. Mainshaft	F 15330	1
Splitter Gear	F 15295	1
Countershaft Front	F 19085	2
Countershaft Rear	F 19067	2
Rev. Idler Gear	F 19095	2
Aux. Countershaft Front	F 15112	2
Aux. Countershaft Rear	F 15112	2

FTRK 3598 OB		
Input Shaft	6212 ZNR/C3	1
Aux. Drive Gear	F 18036	1
Aux. Mainshaft	F 15330	1
Splitter Gear	F 15295	1
Countershaft Front	F 19085	2
Countershaft Rear	F 19067	2
Rev. Idler Gear	F 19095	2
Aux. Countershaft Front	F 15112	2
Aux. Countershaft Rear	F 15112	2

FTRK 3599 OB		
Clutch Pilot	6306 2RS NR	1
Input Shaft	6212 ZNR/C3	1
Front Cover	*	1

FTRK 3600 OB		
Clutch Pilot	6306 2RS	1
Input Shaft	F 19088	1
Front Cover	*	1

POSITION	FERSA	QTY
FTRK 3601 OB		
Clutch Pilot	6306 2RS NR	1
Input Shaft	F 19088	1
Front Cover	*	1

FTRK 3655 OB		
Input Shaft	F 19088	1
Aux. Drive Gear	*	1
Aux. Mainshaft	*	1
Countershaft Front	F 19085	2
Countershaft Rear	*	2
Rev. Idler Gear	F 19095	2
Range Shaft Quill Front	6204	1
Aux. Countershaft Front	*	2
Aux. Countershaft Rear	6310 NR	2
Front Cover	*	1

FTRK 3656 OB		
Input Shaft	F 19088	1
Aux. Drive Gear	*	1
Aux. Mainshaft	*	1
Countershaft Front	F 19085	2
Countershaft Rear	*	2
Rev. Idler Gear	F 19095	2
Range Shaft Quill Front	6204	1
Aux. Countershaft Front	*	2
Aux. Countershaft Rear	6310 NR	2
Front Cover	*	1

FTRK 3657 OB		
Input Shaft	F 19088	1
Aux. Drive Gear	*	1
Aux. Mainshaft	*	1
Countershaft Front	F 19085	2
Countershaft Rear	*	2
Rev. Idler Gear	F 19095	2
Aux. Countershaft Front	F 15112	2
Aux. Countershaft Rear	F 15112	2

FTRK 3658 OB		
Input Shaft	F 19088	1
Aux. Drive Gear	*	1
Aux. Mainshaft	*	1
Countershaft Front	F 19085	2
Countershaft Rear	*	2
Rev. Idler Gear	F 19095	2
Aux. Countershaft Front	F 15112	2
Aux. Countershaft Rear	F 15112	2

POSITION	FERSA	QTY
FTRK 3659 OB		
Input Shaft	F 19088	1
Aux. Drive Gear	*	1
Aux. Mainshaft	*	1
Countershaft Front	F 19085	2
Countershaft Rear	*	2
Rev. Idler Gear	F 19095	2
Range Shaft Quill Front	6204	1
Aux. Countershaft Front	*	2
Aux. Countershaft Rear	6310 NR	2

FTRK 3660 OB		
Input Shaft	F 19088	1
Aux. Drive Gear	*	1
Aux. Mainshaft	*	1
Countershaft Front	F 19085	2
Countershaft Rear	*	2
Rev. Idler Gear	F 19095	2
Aux. Countershaft Front	F 15112	2
Aux. Countershaft Rear	F 15112	2

FTRK 3661 OB		
Input Shaft	F 19088	1
Aux. Drive Gear	*	1
Aux. Mainshaft	F 15330	1
Countershaft Front	F 19085	2
Countershaft Rear	*	2
Rev. Idler Gear	F 19095	2
Aux. Countershaft Front	F 15112	2
Aux. Countershaft Rear	F 15112	2

FTRK 3762 OB		
Clutch Pilot	6306 2RS	1
Input Shaft	F 19088	1
Front Cover	*	1

FTRK 3941 OB		
Input Shaft	*	1
Aux. Drive Gear	F 18037	1
Aux. Mainshaft	*	1
Splitter Gear	F 15295	1
Splitter Gear Sleeve	*	1
Countershaft Front	F 19085	2
Countershaft Rear	F 19067	2
Rev. Idler Gear	F 19095	2
Aux. Countershaft Front	F 15109	2
Aux. Countershaft Rear	F 15109	2

2.2 \ F-Box Transmission Rebuild Kit

POSITION	FERSA	QTY
FTRK 3942 OB		
Input Shaft	*	1
Aux. Drive Gear	F 18036	1
Aux. Mainshaft	*	1
Countershaft Front	F 19085	2
Countershaft Rear	*	2
Rev. Idler Gear	F 19095	2
Aux. Countershaft Front	F 15112	2
Aux. Countershaft Rear	F 15112	2

FTRK 4010 OB		
Input Shaft	*	1
Aux. Drive Gear	F 18036	1
Aux. Mainshaft	*	1
Countershaft Front	F 19085	2
Countershaft Rear	F 19067	2
Rev. Idler Gear	F 19095	2
Aux. Countershaft Front	F 15112	2
Aux. Countershaft Rear	F 15112	2

FTRK 4056 OB		
Input Shaft	F 19088	1
Aux. Drive Gear	F 18036	1
Aux. Mainshaft	F 15330	1
Splitter Gear	F 15295	1
Countershaft Front	F 19085	2
Countershaft Rear	F 19067	2
Rev. Idler Gear	F 19095	2
Aux. Countershaft Front	F 15112	2
Aux. Countershaft Rear	F 15112	2

FTRK 4057 OB		
Input Shaft	F 19088	1
Aux. Drive Gear	F 18036	1
Aux. Mainshaft	F 15330	1
Splitter Gear	F 15295	1
Countershaft Front	F 19085	2
Countershaft Rear	F 19067	2
Rev. Idler Gear	F 19095	2
Aux. Countershaft Front	F 15112	2
Aux. Countershaft Rear	F 15112	2

FTRK 4092 OB		
Input Shaft	F 19088	1
Aux. Drive Gear	F 18036	1
Aux. Mainshaft	F 15330	1
Countershaft Front	F 19085	2
Countershaft Rear	*	2
Rev. Idler Gear	F 19095	2
Aux. Countershaft Front	F 15112	2
Aux. Countershaft Rear	F 15112	2

POSITION	FERSA	QTY
FTRK 5000CK OB		
Clutch Pilot	6306 2RS	1
Input Shaft	6212 ZNR/C3	1
Front Cover	*	1

FTRK 5356 OB		
Input Shaft	6212 ZNR/C3	1
Input Shaft Pilot	*	1
Aux. Drive Gear	6019 NR	1
Aux. Mainshaft	*	1
Countershaft Front	*	2
Countershaft Rear	*	2
Rev. Idler Gear	*	2
Aux. Countershaft Front	*	2
Aux. Countershaft Rear	3782/3720	2

FTRK 5357 OB		
Input Shaft	6212 ZNR/C3	1
Input Shaft Pilot	*	1
Aux. Drive Gear	6019 NR	1
Aux. Mainshaft	*	1
Countershaft Front	*	2
Countershaft Rear	*	2
Rev. Idler Gear	*	2
Aux. Countershaft Front	*	2
Aux. Countershaft Rear	3782/3720	2

FTRK 5358 OB		
Input Shaft	6212 ZNR/C3	1
Input Shaft Pilot	*	1
Aux. Drive Gear	6019 NR	1
Aux. Mainshaft	*	1
Countershaft Front	*	2
Countershaft Rear	*	2
Rev. Idler Gear	*	2
Aux. Countershaft Front	*	2
Aux. Countershaft Rear	3782/3720	2

FTRK 5406 OB		
Input Shaft	6212 ZNR/C3	1
Input Shaft Pilot	*	1
Aux. Drive Gear	6019 NR	1
Aux. Mainshaft	*	1
Countershaft Front	*	2
Countershaft Rear	*	2
Rev. Idler Gear	*	2
Aux. Countershaft Front	*	2
Aux. Countershaft Rear	*	2

POSITION	FERSA	QTY
FTRK 7000 OB		
Input Shaft	M 802048/M 802011	1
Input Shaft Pilot	*	1
Output Shaft	25581/25520	1
Countershaft Front	25877/25821	1
Countershaft Rear	2689/2631	1
Rev. Idler Gear	*	1
Mainshaft 1st & 2nd Gear	*	2
Mainshaft 3rd & Rev. Gear	*	2
Mainshaft 4th Gear	*	1
4th & 5th Shift Hub	*	1

FTRK 7013 OB		
Input Shaft	M 804049/M 804010	1
Input Shaft Pilot	*	1
Output Shaft	25581/25520	1
Countershaft Front	25877/25821	1
Countershaft Rear	2689/2631	1
Rev. Idler Gear	*	1
Mainshaft 1st & 2nd Gear	*	2
Mainshaft 3rd & Rev. Gear	*	2
Mainshaft 4th Gear	*	1
4th & 5th Shift Hub	*	1

FTRK 7032 OB		
Input Shaft	M 802048/M 802011	1
Input Shaft Pilot	*	1
Output Shaft	28580 A/28527 RB	1
Countershaft Front & Rear	25590/25520	2
4th & 5th Shift Hub	*	1
Mainshaft 1st Gear	*	1
Mainshaft 2nd, 3rd & Rev. Gear	*	3
Mainshaft 4th Gear	*	1
Rev. Idler Gear	*	1

FTRK 7033 OB		
Input Shaft	M 804049/M 804010	1
Input Shaft Pilot	*	1
Output Shaft	28580 A/28527 RB	1
Countershaft Front & Rear	25590/25520	2
4th & 5th Shift Hub	*	1
Mainshaft 1st Gear	*	1
Mainshaft 2nd, 3rd & Rev. Gear	*	3
Mainshaft 4th Gear	*	1
Rev. Idler Gear	*	1

POSITION	FERSA	QTY
FTRK 7035 OB		
Input Shaft	39590/39520	1
Input Shaft Pilot	CONE 31594	1
Output Shaft	45285 A/45220	1
Countershaft Front	25590/25522	1
Countershaft Rear	3782/3720	1
1st & Rev. Gear	F 17044 K	4
2nd Gear	F 17043 K	2
3rd Gear	F 17046 K	2
4th Gear	F 17045 K	2
Rev. Idler Gear	F 17106 K	2

FTRK 7052 OB		
Input Shaft 1.750"	39590/39520	1
Input Shaft 1.500"	45284/45220	1
Input Shaft Pilot	CONE 31594	1
Output Shaft	45285 A/45220	1
Countershaft Front	25590/25522	1
Countershaft Rear	3782/3720	1
1st & 2nd Gear	F 17044 K	4
3rd Gear	F 17043 K	2
4th & Rev. Gear	F 17046 K	2
5th Gear	F 17045 K	2
Rev. Idler Gear	F 17106 K	2

FTRK 101-432-1X OB		
Input Shaft	6213 NR	1
Input Shaft Pilot	*	1
Output Shaft Center	6213 NR	1
Output Shaft Rear	*	1
Countershaft Front	2788 A/2729	1
Countershaft Center	*	1
Countershaft Rear	2788 A/2729	1
Rev. Idler Gear	*	2
1st Gear	*	1
2nd Gear	*	1
3rd Gear	*	1
4th Gear	F 17043 K	1
4th Gear	*	1
4th/5th Shift Hub	*	2
6th Gear	*	2
Rev. Gear	*	1

FTRK 312476-22X OB		
Intermediate Shaft Front	2788/2720	1
Intermediate Shaft Rear	25877/25821	1
Output Shaft	*	2
Rev. Shaft	*	2

2.2 \ F-Box Transmission Rebuild Kit

POSITION	FERSA	QTY
FTRK 313432-10X OB		
Input Shaft	JM 511946/JM 511910	1
Input Shaft Pilot	CONE 2580	1
Output Shaft	JM 511946/JM 511910	1
Countershaft Front	25584/25520	1
Countershaft Rear	25584/25520	1
Rev. Idler Gear	*	2
Mainshaft 1st Gear	*	1
Mainshaft 2nd Gear	*	1
Mainshaft Rev. Gear	*	1

FTRK 313432-11X OB		
Input Shaft	*	1
Input Shaft Pilot	*	1
Output Shaft	*	1
Countershaft Front	LM 48548/LM 48510	1
Countershaft Rear	LM 102949/LM 102910	1
Mainshaft 1st and Rev. Gear	*	2
Mainshaft 2nd Gear	*	1
Rev. Idler Gear	*	2

FTRK 313432-14X OB		
Input Shaft Front	*	1
Input Shaft Pilot	*	1
Output Shaft	*	1
Countershaft Front	*	2
Countershaft Rear	*	2
Rev. Idler Gear	*	4

FTRK 313432-1X OB		
Input Shaft	*	1
Input Shaft Pilot	*	1
Output Shaft	*	1
Countershaft Front	6311 NR	2
Countershaft Rear	*	2
Rev. Idler Gear	*	4

FTRK 313432-20X OB		
Input Shaft	JM 511946/JM 511910	1
Input Shaft Pilot	25877/25821	1
Output Shaft	3979/JM 511910	1
Countershaft Front	M 804049/M 804010	1
Countershaft Rear	JLM 506849/JLM 506810	1
Rev. Idler Gear	*	2
Mainshaft 1st & Rev. Gear	*	2
Mainshaft 2nd Gear Needle	*	1

POSITION	FERSA	QTY
FTRK 313432-21X OB		
Input Shaft Front	6210	1
Input Shaft Rear	*	1
Input Shaft Pilot	*	1
Output Shaft	6312 NR	1
Countershaft Front	3877/3820	1
Countershaft Rear	462/453 A	1
Speed Gear	*	1

FTRK 313432-25X OB		
Input Shaft	*	1
Input Shaft Pilot	*	1
Output Shaft	*	1
Countershaft Front	6311 NR	2
Countershaft Rear	*	2
Rev. Idler Gear	*	4

FTRK 313432-2X OB		
Input Shaft	*	1
Input Shaft Pilot	*	1
Output Shaft	*	1
Countershaft Front	6311 NR	2
Countershaft Rear	*	2
Rev. Idler Gear	*	4

FTRK 313432-30X OB		
Input Shaft	*	1
Input Shaft Pilot	*	1
Output Shaft	*	1
Countershaft Front	LM 48548/LM 48510	1
Countershaft Rear	2788 A/2729	1
Rev. Idler Gear	*	2
1st Gear	*	1
2nd Gear	*	2
3rd Gear	*	1
4th Gear	*	1

FTRK 313432-31X OB		
Input Shaft	JM 511946/JM 511910	1
Input Shaft Pilot	CONE 2580	1
Output Shaft	JM 511946/JM 511910	1
Countershaft Front	25584/25520	1
Countershaft Rear	25584/25520	1
Rev. Idler Gear	*	2
Mainshaft 1st Gear	*	1
Mainshaft 2nd Gear	*	1
Mainshaft Rev. Gear	*	1

3 \

WHEEL END





3 Wheel End

SET	Fersa	POSITION MODEL
SET 401	580/572	R Drive Axle - Outer
SET 402	582/572	R Drive Axle - Outer - Mack
SET 403	594 A/592 A	R Drive Axle - Inner
SET 404	598 A/ 592 A	R Drive Axle - Inner - Mack
SET 405	663/653	Trailer Axle Inner & Rear Drive Axle/Trailer -Outer
SET 406	3782/3720	FF Steer Axle - Outer
SET 407	28682/28622	Rear Axle - Inner& Front Steer Axle-Outer
SET 408	39590/39520	L Drive Axle - Outer
SET 409	45280/45220	Front Steer Axle-Outer-Mack
SET 410	45284/45220	Front Steer Axle- Inner
SET 411	47686/47620	L Drive Axle - Inner
SET 412	HM 212047/HM 212011	FF Steer Axle-Inner& N Trailer Axle-Outer
SET 413	HM 212049/HM 212011	FF Steer Axle-Inner & N Trailer-Outer
SET 414	HM 218248/HM 218210	N Trailer Axle - Inner
SET 415	HM 518445/HM 518410	P Trailer Axle- Inner & Outer
SET 416	45291/45220	Trailer Axle
SET 417	47890/47820	Trailer Axle
SET 418	H 715334/H 715311	Front Steer Axle - Inner
SET 419	H 715343/H 715311	Front Steer Axle - Inner
SET 420	H 715345/H 715311	Front Steer Axle - Inner
SET 421	HM 516449A/HM 516410	Rear Axle - Inner - Mack
SET 422	HM 516449 C/HM 516410	Rear Axle - Inner - Mack
SET 423	6461 A/6420	FL Steer Axle - Inner
SET 424	555 S/552 A	FL Steer Axle - Outer
SET 425	567/563	Front Steer Axle/Trailer Axle-Inner & Rear Axle -Outer - Mack
SET 426	47679/47620	Rear Axle - Outer - Mack





A large area of the page is filled with horizontal dotted lines, providing a template for writing or drawing.

4 \

MANUFACTURER
PART NUMBERS



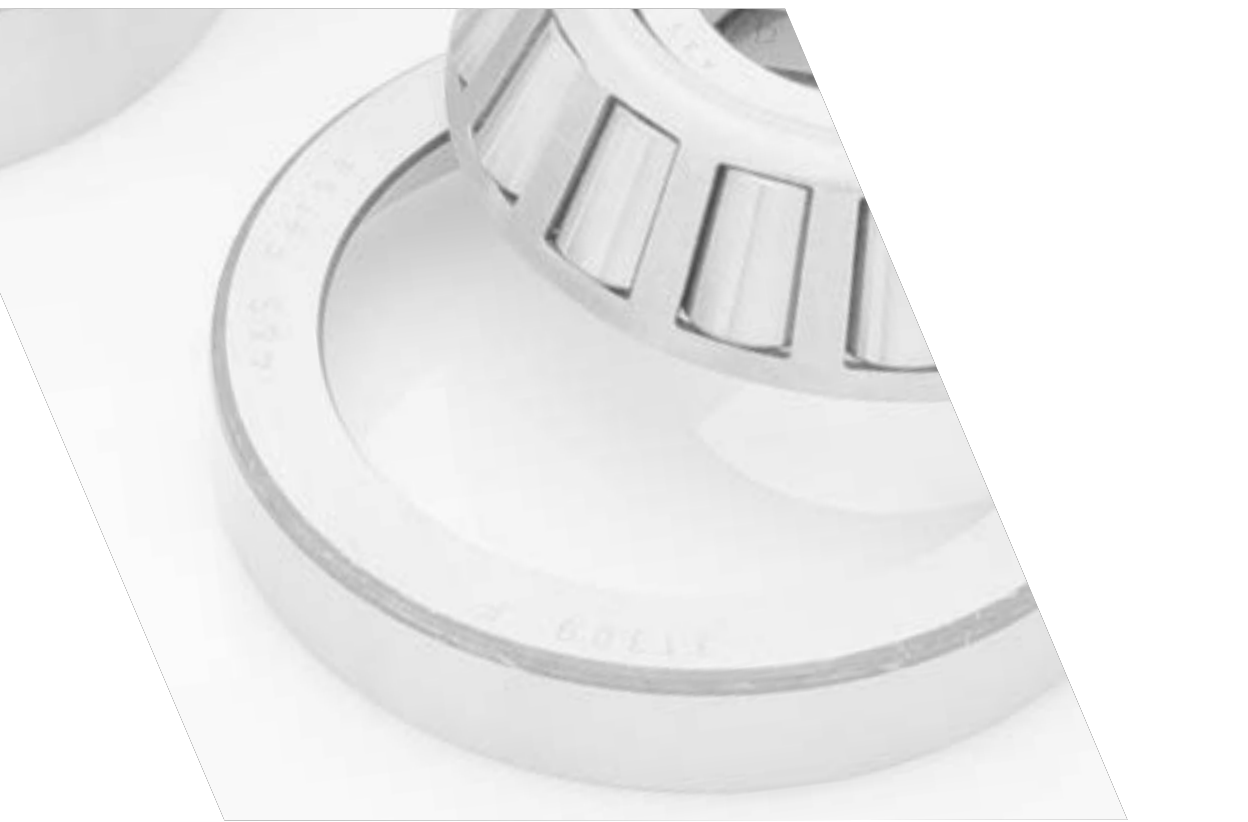

4 \ Manufacturer Part Numbers

Manufacturer Parts	FERSA
Dana	
6082	CONE 567
9803	CUP 493
9804	CONE 498
10737	CUP 3820
12495	CUP 55437
12496	CONE 55200 C
12500	CUP 52618
12501	CONE 52400
14218	CONE 72212 C
15092	CUP 42584
15094	CONE 495 A
19529	CUP 653
21632	CUP 68712
24328	CUP 33472
24330	CONE 33275
27238	CUP 78551
27813	CONE 497
27816	CUP 56650
27817	CONE 56425
27876	CONE 42381
30689	CONE 39590
30692	CONE 47686
31824	CUP 592 A
31825	CONE 598
34368	CONE 580
34539	CONE 749
35502	CUP HM 807010
40679	CONE 3994
45460	CONE 72200 C
49848	CONE HM 903249
49849	CUP HM 903210
78930	6313
83824	CUP JM 822010
83825	CONE JM 822049
85439	CONE 72218 C
90943	CUP 563
90951	CUP 3920
90954	CONE 575
90955	CUP 572
91136	CONE 3979
98384	CONE JH 211749
98385	CUP JH 211710
98387	CONE JM 511946
98388	CUP JM 511910
99041	FDRK 1A
99048	FDRK 24
99050	FDRK 23D
99051	FDRK 1
99053	FDRK 72A
99096	FDRK 18E
99906	CONE 594 A
102660	CONE 68462
107670	FDRK 72B

Manufacturer Parts	FERSA
109368	FDRK 412
110555	FDRK 1AMK
110811	CUP 29620
110812	CONE 29675
110846	CONE HM 807049
111355	CUP HM 88610
111356	CONE HM 88649
113868	CONE HM 813841
113869	CUP HM 813810
114394	FDRK 196
114399	FDRK 196MK
115125	FDRK 207
118118	FDRK 210
118122	FDRK 208
119681	CONE 33262
119797	FDRK 402
122421	FDRK 211FMK1
122437	FDRK 208MK
122448	FDRK 219RMK
122657	FDRK 211FMK2
123297	FDRK 409MK
124487	FDRK 222FMK
126187	F 19084
126987	CONE 6580
126988	CUP 6535
127484	F 19100
127485	F 19099
127535	CONE 55212 C
127536	CUP 29630
127539	CUP JLM 104910
127540	CONE LM 104949
128604	CONE 42362
131041	CONE 64452 A
131042	CONE F 15362
131050	CONE F 15328
131052	CONE F 15327
132060	CONE 29688
210474	CUP H 913810
210475	CONE H 913842
210588	F 19086
211218	FDRK 222RMK
211222	FDRK 222F
211223	FDRK 222R
216220	FDRK 404FMK
216221	FDRK 404RMK
216234	FDRK 404F
216248	FDRK 404R
217463	FDRK 405FMK
217464	FDRK 405RMK
217621	FDRK 211FMK
217622	FDRK 219RMK1
504030	FDRK 427AMK
504031	FDRK 405FAMK
504033	FDRK 427AMK

Manufacturer Parts	FERSA
Dana	
504034	FDRK 405FAMK
504117	FDRK 405F
504118	FDRK 404FMK
504119	FDRK 404R
504120	FDRK 404F
504121	FDRK 404RMK
504126	FDRK 442A
504127	FDRK 436A
504128	FDRK 437A
504129	FDRK 438A
504130	FDRK 439A
504131	FDRK 443A
504132	FDRK 444A
504133	FDRK 441A
509689	FDRK 412
509690	FDRK 412MK
509691	FDRK 196MK1
510393	FDRK 427MK
510398	FDRK 429MK
510399	FDRK 428MK
510400	FDRK 430MK
511891	FDRK 451MK
512800	FDRK 428
512803	FDRK 400
512804	FDRK 221
512805	FDRK 430
512806	FDRK 429
512812	FDRK 427
512814	FDRK 449
512828	FDRK 445
512829	FDRK 446
514011	FDRK 436
514012	FDRK 437
514013	FDRK 438
514014	FDRK 439
514015	FDRK 443
514016	FDRK 441
514059	FDRK 447
514238	FDRK 442
514240	FDRK 444
550182	CONE 25590
550225	CUP 25523
550348	CUP 39520
566071	CONE 33281
708244	M 802048/M 802011
820642	CONE 6461 A
820643	CONE 555 S
1008585	CONE HM 212049
1008586	CONE 3782
1008911	CUP HM 212011
2005082	JLM 104948/JLM 104910
2007293	JLM 704649/JLM 704610
258452C1	CUP 28921

Manufacturer Parts	FERSA
258453C91	CONE 28985
300HD100	F 19033
300KS100-X	FDRK 416
341KS101	FDRK 191R
360HA100	CUP 72487
360HB100	CONE 72225 C
360KS100-X	FDRK 414
390HA100	CUP JLM 710910
390HB101	CONE JLM 71949
390KS103-X	FDRK 411R
390KS105-X	FDRK 411F
401HA100	CUP HM 807010
401KS100-X	FDRK 223F
401KS101-X	FDRK 223R
472KS101	FDRK 192RB
472KS113	FDRK 200FA
474KS101	FDRK 201R
474KS102	FDRK 201FA
483067C91	CONE HM 813844
483068C1	CUP HM 813810
706015X	HM 88649/HM 88610
706030X	02872/02820
706045X	HM 88542/HM 88510
706046X	HM 803146/HM 803110
706060X	HM 807040/HM 807010
706861X	HM 803149/HM 803110
706894X	M 86649/M 86610
707064X	M 802048/M 802011
707065X	M 802048/M 802011
707066X	HM 807046/HM 807010
707162X	HM 88648/HM 88610
917217R1	CUP HM 903210
GGAHA100	CUP 42584
GGAHA101	CUP 493
GGAHA109	CUP M 802011
GGAHB100	CONE 42381
GGAHB101	CONE 495
GGAHB102	CONE 39590
GGAHB104	CONE 555 S
GGAHB105	CONE HM 807049
GGAHB106	CONE M 802048
GGAKA101-X	FDRK 213
H500445	CONE 3782
HA100	CUP H 715311
HA101	CUP 56650
HA102	CUP 3920
HA105	CUP 6420
HB102	CONE 56425
HB103	CONE H 715343
HB104	CONE 55175 C
HB105	CONE 3984
HB106	CONE H 715343
MJAHA100	CUP JM 822010
MJAHA103	CUP JM 716610

4 \ Manufacturer Part Numbers

Manufacturer Parts	FERSA
Dana	
MJAHB100	CONE JM 822049
MJAHB103	CONE JM 716649
MJAKA101-X	FDRK 214
ST2161	CUP 47820
ST2162	CONE 47890
ST264	6210
ST741	6022 NR
ST791	CONE 3877
ST951	CUP 3820

Eaton	
14287	F 19095
20607	F 19034
20899	F 19101
81012	6311 NR
81017	6212 Z
81022	6309 NR
81029	6212 NR
81052	6310 NR
81504	6212 ZNR/C3
81505	6017 NR
81511	6308
81547	6204
81549	6213
81559	6017
710787	CONE 31594
3315674	F 17106 K
3315703	F 17044 K
3315722	F 17043 K
3315737	F 17045 K
4124075	F 17046 K
4301417	F 19088
4301851	F 15109
4301851	F 15109
4302074	F 15112
4302712	F 19067
4304080	F 19094
4304599	F 19085
4308403	F 19095
5556503	F 15330
5566505	6306 2RS C3
5566508	F 18036
5566510	F 18037
5566511	6306 2RS NR
K-1063	FTRK 1063
K-1064	FTRK 1064
K-1079	FTRK 1079
K-1554	FTRK 1554
K-1555	FTRK 1555
K-1763	FTRK 1763
K-1765	FTRK 1765
K-1850	FTRK 1850
K-1851	FTRK 1851
K-1852	FTRK 1852
K-1855	FTRK 1855

Manufacturer Parts	FERSA
K-1858	FTRK 1858
K-1859	FTRK 1859
K-1860	FTRK 1860
K-1861	FTRK 1861
K-1862	FTRK 1862
K-1863	FTRK 1863
K-1866	FTRK 1866
K-1867	FTRK 1867
K-1870	FTRK 1870
K-1871	FTRK 1871
K-1872	FTRK 1872
K-1873	FTRK 1873
K-1874	FTRK 1874
K-1875	FTRK 1875
K-1876	FTRK 1876
K-1877	FTRK 1877
K-1971	FTRK 1971
K-1972	FTRK 1972
K-1979	FTRK 1979
K-1980	FTRK 1980
K-1981	FTRK 1981
K-1982	FTRK 1982
K-1984	FTRK 1984
K-1986	FTRK 1986
K-1991	FTRK 1991
K-1992	FTRK 1992
K-1993	FTRK 1993
K-1995	FTRK 1995
K-1996	FTRK 1996
K-1999	FTRK 1999
K-2041	FTRK 2041
K-2043	FTRK 2043
K-2045	FTRK 2045
K-2047	FTRK 2047
K-2048	FTRK 2048
K-2049	FTRK 2049
K-2120	FTRK 2120
K-2121	FTRK 2121
K-2122	FTRK 2122
K-2123	FTRK 2123
K-2124	FTRK 2124
K-2125	FTRK 2125
K-2126	FTRK 2126
K-2127	FTRK 2127
K-2128	FTRK 2128
K-2129	FTRK 2129
K-2130	FTRK 2130
K-2131	FTRK 2131
K-2275	FTRK 2275
K-2277	FTRK 2277
K-2280	FTRK 2280
K-2281	FTRK 2281
K-2282	FTRK 2282
K-2283	FTRK 2283

Manufacturer Parts	FERSA
Eaton	
K-2284	FTRK 2284
K-2285	FTRK 2285
K-2286	FTRK 2286
K-2287	FTRK 2287
K-2288	FTRK 2288
K-2335	FTRK 2335
K-2336	FTRK 2336
K-2338	FTRK 2338
K-2340	FTRK 2340
K-2341	FTRK 2341
K-2342	FTRK 2342
K-2343	FTRK 2343
K-2344	FTRK 2344
K-2345	FTRK 2345
K-2464	FTRK 2464
K-2468	FTRK 2468
K-2490	FTRK 2490
K-2758	FTRK 2758
K-2759	FTRK 2759
K-2761	FTRK 2761
K-2762	FTRK 2762
K-2763	FTRK 2763
K-2764	FTRK 2764
K-2765	FTRK 2765
K-2767	FTRK 2767
K-2768	FTRK 2768
K-2769	FTRK 2769
K-2770	FTRK 2770
K-2771	FTRK 2771
K-2772	FTRK 2772
K-2773	FTRK 2773
K-2779	FTRK 2779
K-2780	FTRK 2780
K-2838	FTRK 2838
K-2847	FTRK 2847
K-2848	FTRK 2848
K-2855	FTRK 2855
K-2865	FTRK 2865
K-2866	FTRK 2866
K-2924	FTRK 2924
K-2993	FTRK 2993
K-2994	FTRK 2994
K-2996	FTRK 2996
K-2997	FTRK 2997
K-2998	FTRK 2998
K-3132	FTRK 3132
K-3233	FTRK 3233
K-3234	FTRK 3234
K-3256	FTRK 3256
K-3257	FTRK 3257
K-3258	FTRK 3258
K-3272	FTRK 3272
K-3273	FTRK 3273

Manufacturer Parts	FERSA
K-3282	FTRK 3282
K-3283	FTRK 3283
K-3286	FTRK 3286
K-3287	FTRK 3287
K-3322	FTRK 3322
K-3323	FTRK 3323
K-3339	FTRK 3339
K-3340	FTRK 3340
K-3342	FTRK 3342
K-3343	FTRK 3343
K-3344	FTRK 3344
K-3345	FTRK 3345
K-3346	FTRK 3346
K-3347	FTRK 3347
K-3348	FTRK 3348
K-3350	FTRK 3350
K-3351	FTRK 3351
K-3354	FTRK 3354
K-3355	FTRK 3355
K-3413	FTRK 3413
K-3414	FTRK 3414
K-3423	FTRK 3423
K-3425	FTRK 3425
K-3426	FTRK 3426
K-3440	FTRK 3440
K-3459	FTRK 3459
K-3460	FTRK 3460
K-3461	FTRK 3461
K-3462	FTRK 3462
K-3486	FTRK 3486
K-3487	FTRK 3487
K-3488	FTRK 3488
K-3512	FTRK 3512
K-3513	FTRK 3513
K-3514	FTRK 3514
K-3515	FTRK 3515
K-3519	FTRK 3519
K-3522	FTRK 3522
K-3524	FTRK 3524
K-3533	FTRK 3533
K-3534	FTRK 3534
K-3553	FTRK 3553
K-3554	FTRK 3554
K-3585	FTRK 3585
K-3586	FTRK 3586
K-3595	FTRK 3595
K-3596	FTRK 3596
K-3597	FTRK 3597
K-3598	FTRK 3598
K-3600	FTRK 3600
K-3655	FTRK 3655
K-3656	FTRK 3656
K-3657	FTRK 3657
K-3658	FTRK 3658

4 \ Manufacturer Part Numbers

Manufacturer Parts	FERSA
Eaton	
K-3659	FTRK 3659
K-3660	FTRK 3660
K-3661	FTRK 3661
K-3919	25581/25520
K-3941	FTRK 3941
K-3942	FTRK 3942
K-4010	FTRK 4010
K-4011	FTRK 4011
K-4056	FTRK 4056
K-4057	FTRK 4057
K-4092	FTRK 4092
K-4152	39590/39520
K-4154	M 802048/M 802011
K-7000	FTRK 7000
K-7013	FTRK 7013
K-7032	FTRK 7032
K-7033	FTRK 7033
K-7035	FTRK 7035
K-7052	FTRK 7052

Meritor	
332	CUP 332
339	CONE 339
353	CUP 353
382	CUP 382
382A	CUP 382 A
382S	CUP 382 S
385	CONE 385
385A	CONE 385 A
387	CONE 387
387A	CONE 387 A
387AS	CONE 387 AS
390	CONE 390
392	CONE 392
394A	CUP 394 A
395	CONE 395
395A	CONE 395 A
396	CONE 396
399A	CONE 399 A
453X	CUP 453 X
454	CUP 454
462	CONE 462
469	CONE 469
492A	CUP 492 A
493	CUP 493
495	CONE 495
495A	CONE 495 A
496	CONE 496
497	CONE 497
522	CONE 522
552A	CUP 552 A
528	CONE 528
555S	CONE 555 S

Manufacturer Parts	FERSA
563	CUP 563
566	CONE 566
567	CONE 567
572	CUP 572
572A	CUP 572 A
575	CONE 575
576	CONE 576
580	CONE 580
581	CONE 581
582	CONE 582
592	CUP 592
592A	CUP 592 A
593	CUP 593
593X	CUP 593 X
594	CONE 594
594A	CONE 594 A
595	CONE 595
596	CONE 596
598	CONE 598
598A	CONE 598 A
612	CUP 612
621	CONE 621
632	CUP 632
633	CUP 633
641	CONE 641
643	CONE 643
652	CUP 652
653	CUP 653
663	CONE 663
665A	CONE 665 A
672	CUP 672
681A	CONE 681 A
683	CONE 683
687	CONE 687
740	CONE 740
742	CUP 742
749	CONE 749
752	CUP 752
759	CONE 759
749A	CONE 749 A
2580	CONE 2580
2720	CUP 2720
3520	CUP 3520
3525	CUP 3525
3585	CONE 3585
3720	CUP 3720
3767	CONE 3767
3775	CONE 3775
3782	CONE 3782
3820	CUP 3820
3877	CONE 3877
3920	CUP 3920
3925	CUP 3925
3979	CONE 3979

Manufacturer Parts	FERSA
Meritor	
3982	CONE 3982
3984	CONE 3984
3994	CONE 3994
4535	CUP 4535
5735	CUP 5735
5760	CONE 5760
6320	CUP 6320
6379	CONE 6379
6420	CUP 6420
6461	CONE 6461
6461A	CONE 6461 A
6535	CUP 6535
6580	CONE 6580
9220	CUP 9220
9278	CONE 9278
14276	CUP 14276
15101	CONE 15101
15117	CONE 15117
15126	CONE 15126
15243	CUP 15243
15245	CUP 15245
18720	CUP 18720
21075	CONE 21075
25520	CUP 25520
25523	CUP 25523
25580	CONE 25580
25584	CONE 25584
25820	CUP 25820
25821	CUP 25821
25877	CONE 25877
25878	CONE 25878
25880	CONE 25880
28521	CUP 28521
28580	CONE 28580
28622	CUP 28622
28682	CONE 28682
28921	CUP 28921
28985	CONE 28985
29620	CUP 29620
29630	CUP 29630
29675	CONE 29675
29685	CONE 29685
31520	CUP 31520
31594	CONE 31594
31597	CONE 31597
32210	32210 F
33208	33208 F
33211	33211 F
33212	33212 F
33275	CONE 33275
33281	CONE 33281
33287	CONE 33287
33462	CUP 33462

Manufacturer Parts	FERSA
33472	CUP 33472
34300	CONE 34300
34306	CONE 34306
34478	CUP 34478
37625	CUP 37625
39520	CUP 39520
39580	CONE 39580
39581	CONE 39581
39585	CONE 39585
39590	CONE 39590
42350	CONE 42350
42381	CONE 42381
42584	CUP 42584
42620	CUP 42620
42688	CONE 42688
44348	CUP 44348
45220	CUP 45220
45280	CONE 45280
45284	CONE 45284
45291	CONE 45291
47420	CUP 47420
47490	CONE 47490
47620	CUP 47620
47623A	CUP 47623 A
47679	CONE 47679
47686	CONE 47686
47687	CONE 47687
47820	CUP 47820
47890	CONE 47890
48220	CUP 48220
48290	CONE 48290
52400	CONE 52400
52618	CUP 52618
55175C	CONE 55175 C
55187C	CONE 55187 C
55200C	CONE 55200 C
55206C	CONE 55206 C
55437	CUP 55437
56650	CUP 56650
59412	CUP 59412
64450	CONE 64450
64700	CUP 64700
65237	CONE 65237
65500	CUP 65500
67322	CUP 67322
67391	CONE 67391
68462	CONE 68462
68712	CUP 68712
72200C	CONE 72200 C
72212C	CONE 72212 C
72218C	CONE 72218 C
72225C	CONE 72225 C
72487	CUP 72487
78215C	CONE 78215 C

4 \ Manufacturer Part Numbers

Manufacturer Parts	FERSA
Meritor	
78225C	CONE 78225 C
78551	CUP 78551
1228B1042	F 19033
1228C3	6209
1228C55	F 19040
1228E1045	F 19100
1228F136	F 19077
1228F552	F 19035
1228G1203	6212 ZNR/C3
1228J192	6210
1228L1130	CUP JP 10010
1228L194	6212
1228N1262	6211
1228N1938	CUP JLM 714110
1228P250	6313
1228Q1473	CUP 592 A
1228R200	6209
1228S1267	F 19063
1228U645	CUP 55437
1228U1217	CUP 3920
1228V594	CONE 9278
1228X154	F 19034
1228Z1716	CUP H 715311
1828K219	6311 NR
1828S149	6211 NR
1828S201	6309 Z
1828V74	6208 NR
A11228B600	32021 XF
A1228A1717	CONE H 715334
A1228H1204	6019 NR
A1228L1130	CONE JP 10049
A1228N2068	CONE 55206 C
A1228P1940	CONE JLM 714149
A1228R1474	CONE 594 A
A1228U1347	3782/3720
A1228W1713	CONE JM 511945
H715311	CUP H 715311
H715334	CONE H 715334
H715341	CONE H 715341
H715343	CONE H 715343
H715345	CONE H 715345
HM212010	CUP HM 212010
HM212011	CUP HM 212011
HM212044	CONE HM 212044
HM212047	CONE HM 212047
HM212049	CONE HM 212049
HM218210	CUP HM 218210
HM218248	CONE HM 218248
HM516410	CUP HM 516410
HM516448	CONE HM 516448
HM516449A	CONE HM 516449 A
HM516449C	CONE HM 516449 C
HM518410	CUP HM 518410
HM518445	CONE HM 518445

Manufacturer Parts	FERSA
HM801310	CUP HM 801310
HM803110	CUP HM 803110
HM803146	CONE HM 803146
HM803149	CONE HM 803149
HM804810	CUP HM 804810
HM804840	CONE HM 804840
HM804846	CONE HM 804846
HM807010	CUP HM 807010
HM807040	CONE HM 807040
HM807046	CONE HM 807046
HM807049	CONE HM 807049
HM813810	CUP HM 813810
HM813842	CONE HM 813842
HM813843	CONE HM 813843
HM813844	CONE HM 813844
HM88510	CUP HM 88510
HM88542	CONE HM 88542
HM88610	CUP HM 88610
HM88649	CONE HM 88649
HM89411	CONE HM 89411
HM89448	CONE HM 89448
HM89449	CONE HM 89449
HM903210	CUP HM 903210
HM903249	CONE HM 903249
HM911210	CUP HM 911210
HM911245	CONE HM 911245
JH211710	CUP JH 211710
JH211749	CONE JH 211749
JH415610	CUP JH 415610
JH415647	CONE JH 415647
JHM720210	CUP JHM 720210
JHM720249	CONE JHM 720249
JL69310	CUP JL 69310
JL69349	CONE JL 69349
JLM104910	CUP JLM 104910
JLM104948	CONE JLM 104948
JLM506810	CUP JLM 506810
JLM506849	CONE JLM 506849
JLM508748	CONE JLM 508748
JLM710910	CUP JLM 710910
JLM710949C	CONE JLM 71949
JLM714110	CUP JLM 714110
JLM714149	CONE JLM 714149
JM205110	CUP JM 205110
JM205149A	CONE JM 205149 A
JM207010	CUP JM 207010
JM207049	CONE JM 207049
JM207049A	CONE JM 207049 A
JM511910	CUP JM 511910
JM511945	CONE JM 511945
JM511946	CONE JM 511946
JM515610	CUP JM 515610
JM515649	CONE JM 515649
JM612910	CUP JM 612910

Manufacturer Parts	FERSA
Meritor	
JM612949	CONE JM 612949
JM716610	CUP JM 716610
JM716649	CONE JM 716649
JM720210	CUP JM 720210
JM720249	CONE JM 720249
JM822010	CUP JM 822010
JM822049	CONE JM 822049
JP12010	CUP JP 12010
JP12049	CONE JP 12049
KIT1918	FDRK 1918
KIT1984	FDRK 1984
KIT2108	FDRK 2108
KIT2111	FDRK 2111
KIT4005	FDRK 9RC
KIT4010	FDRK 9RB
KIT4015	FDRK 900F
KIT4020	FDRK 9F
KIT4025	FDRK 9R
KIT4035	FDRK 194F
KIT4040	FDRK 194R
KIT4045	FDRK 194RA
KIT4050	FDRK 194RA
KIT4055	FDRK 194F
KIT4060	FDRK 194RB
KIT4065	FDRK 194RB
KIT4075	FDRK 172R
KIT4080	FDRK 172FB
KIT4095	FDRK 4095
KIT4100	FDRK 4100
KIT4105	FDRK 4105
KIT4110	FDRK 50
KIT4115	FDRK 50A
KIT4120	FDRK 203F
KIT4135	FDRK 4135
KIT4140	FDRK 4140
KIT4145	FDRK 4145
KIT4150	FDRK 4150
KIT4155	FDRK 4155
KIT4190	FDRK 4190
KIT4220	FDRK 4220
KIT4230	FDRK 204F
KIT4235	FDRK 204R
KIT4240	FDRK 4240
KIT4245	FDRK 4245
KIT4260	FDRK 4260
KIT4265	FDRK 1910
KIT4270	FDRK 4270
KIT4300	FDRK 4300
KIT4315	FDRK 4315
KIT4330	FDRK 4330
KIT4340	FDRK 218
KIT4345	FDRK 4345
KIT4350	FDRK 4350

Manufacturer Parts	FERSA
KIT4355	FDRK 4355
KIT4356	FDRK 4356
KIT4360	FDRK 4360
KIT4365	FDRK 216
KIT4370	FDRK 225
KIT4375	FDRK 4375
KIT4385	FDRK 224
KIT4390	FDRK 4390
KIT4395	FDRK 4395
KIT4396	FDRK 4396
KIT4400	FDRK 217R
KIT4405	FDRK 4405
KIT4406	FDRK 4406
KIT4415	FDRK 4415
KIT4420	FDRK 4420
KIT4422	FDRK 4422
KIT4423	FDRK 4423
KIT4426	FDRK 4426
KIT4428	FDRK 4428
KIT4437	FDRK 4437
KIT4438	FDRK 4438
KIT4440	FDRK 4440
KIT4441	FDRK 4441
KIT4442	FDRK 4442
KIT4443	FDRK 4443
KIT4444	FDRK 4444
KIT4450	FDRK 4450
KIT4459	FDRK 4435
KIT4460	FDRK 4436
KIT4461	FDRK 4461
KIT4753	FDRK 4753
KIT4841	FDRK 4841
KIT4842	FDRK 4842
KIT4843	FDRK 4843
KIT4844	FDRK 4844
KIT5356	FTRK 5356
KIT5357	FTRK 5357
KIT5406	FTRK 5406
L44610	CUP L 44610
L44643	CONE L 44643
L44649	CONE L 44649
L68111	CUP L 68111
L68149	CONE L 68149
LM102910	CUP LM 102910
LM102949	CONE LM 102949
LM11910	CUP LM 11910
LM11949	CONE LM 11949
LM12710	CUP LM 12710
LM48510	CUP LM 48510
LM48548	CONE LM 48548
LM501310	CUP LM 501310
LM501314	CUP LM 501314
LM501349	CONE LM 501349
LM603011	CUP LM 603011

4 \ Manufacturer Part Numbers

Manufacturer Parts	FERSA
Meritor	
LM603049	CONE LM 603049
LM67010	CUP LM 67010
LM67048	CONE LM 67048
M802011	CUP M 802011
M802048	CONE M 802048
M804010	CUP M 804010
M804049	CONE M 804049
M86610	CUP M 86610
M86649	CONE M 86649
M88010	CUP M 88010
M88048	CONE M 88048
SET6	LM 67048/10
SET45	LM 501349/10
SET401	580/572
SET402	582/572
SET403	594 A/592 A
SET404	598 A/592 A
SET405	663/653
SET406	3782/3720
SET407	28682/28622
SET408	39590/39520
SET409	45280/45220
SET410	45284/45220
SET411	47686/47620
SET412	HM 212047/HM 212011
SET413	HM 212049/HM 212011
SET414	HM 218248/HM 218210
SET415	HM 518445/HM 518410
SET416	45291/45220
SET417	47890/47820
SET418	H 715334/H 715311
SET419	H 715343/H 715311
SET420	H 715345/H 715311
SET421	HN 516449 A/HM 516410
SET422	HM 516449 C/HM 516410
SET423	6461 A/6420
SET424	555 S/552 A
SET425	567/563
SET426	47679/47620
SET430	580/572
SET431	HM 218248/HM 218210

PAI	
ABG-9121	CONE 45280
ABG-9122	CONE 555 S
ABG-9130	CONE HM 212049
ABG-9131	CONE 6461 A
ACU-9061	CUP 563
BBG-6039	CONE LM 104949
BBG-6149	CONE 495
BBG-7070	6310
BBG-7090	CONE 559
BBG-7150	CONE 643

Manufacturer Parts	FERSA
BBG-7154	CONE JM 511945
BBG-7155	CONE JLM 71949
BBG-7157	CONE JM 511946
BBG-7159	CONE 3979
BBG-7160	6309
BBG-7257	CONE 64450
BBG-7277	CONE JM 822049
BBG-7320	6213 NR
BBG-7330	CONE HM 516448
BBG-7331	CONE JM 716649
BBG-7336	CONE JH 211749
BBG-7338	CONE JLM 714149
BBG-7340	CONE 47687
BBG-7341	CONE 47686
BBG-7343	CONE 47890
BBG-7372	CONE 567
BBG-7419	CONE 55206 C
BBG-7421	CONE 598 A
BBG-7430	CONE 5760
BBG-7435	CONE H 715334
BBG-7436	CONE H 715343
BBG-7470	CONE H 715345
BBG-7490	CONE 497
BBG-7510	CONE 576
BBG-7511	CONE 65237
BBG-7623	CONE HM 813843
BBG-7634	CONE 42362
BBG-7640	6211
BBG-7642	6213
BBG-7750	CONE 555
BBG-8941	CONE 28985
BBG-8943	CONE 3877
BBK-7119	FDRK 500
BBK-7121	FDRK 206
BBK-7124	FDRK 212F
BBK-7124-100	FDRK 212F
BBK-7125	FDRK 206
BBK-7139	FDRK 501
BBK-7141	FDRK 205
BBK-7142	FDRK 502
BBK-7143	FDRK 212R
BBK-7144	FDRK 117
BBK-7145	FDRK 117A
BBK-7153	FDRK 503
BCU-7112	CUP HM 807010
BCU-7120	CUP 552 A
BCU-7140	CUP 632
BCU-7170	CUP 612
BCU-7252	CUP 9220
BCU-7256	CUP 64700
BCU-7276	CUP JM 822010
BCU-7332	CUP JM 207010
BCU-7337	CUP JLM 714110
BCU-7342	CUP 47820

Manufacturer Parts	FERSA
PAI	
BCU-7353	CUP 592 A
BCU-7356	CUP 56650
BCU-7390	CUP 47623 A
BCU-7392	CUP JM 716610
BCU-7480	CUP 572
BCU-7481	CUP 6420
BCU-7500	CUP 492 A
BCU-7501	CUP 65500
BCU-7502	CUP 653
BCU-7622	CUP HM 813810
BCU-8942	CUP 28921
BCU-8944	CUP 3820
BCU-8973	CUP 25821
GBG-6033	CONE 3780
GBG-6035	CONE JLM 104948
GBG-6040	CONE 621
GBG-6087	6212 ZNR/C3
GBG-6089	F 19095
GBG-6590	6214 ZNR
GBG-6593	6214 NR
GBG-6594	6214 Z
GBG-6610	6208 NR
GBG-6621	6205
GBG-8954	F 19067
GBG-8965	F 19094
GBG-8966	F 19088
GBG-8968	CONE 399 A
GBK-6560	FTRK 185
GBK-6561	FTRK 187
GBK-6562	FTRK 213
GBK-6563	FTRK 185
GBK-6564	FTRK 500
GBK-6565	FTRK 214MK
GBK-6571	FTRK 501
GBK-6572	FTRK 502
GBK-6573	FTRK 503
GBK-6574	FTRK 213SD
GBK-6605	FTRK 504
GBK-6637	FTRK 214MK1
GCU-6020	CUP 493
GCU-6034	CUP 3720
GCU-6036	CUP JLM 104910
GCU-7453	CUP H 715311
HBG-4815	CONE 582
HBG-4817	CONE 594 A
HBG-4840	CONE 596
HBG-4850	CONE 594
HBG-4860	CONE 580
HBG-6029	CONE 3782
HBG-7163	CONE 28682
HBG-7174	CONE 39581
HBG-7175	CONE 39590
HBG-7371	CONE 52400
HBG-7520	CONE 663

Manufacturer Parts	FERSA
HBG-7550	CONE 47679
HBG-7570	CONE HM 516449
HBG-7571	CONE HM 516449 A
HBG-9065	CONE 560
HBG-9129	CONE HM 212047
HCU-4830	CUP 592
HCU-4880	CUP HM 212010
HCU-5010	CUP 47620
HCU-5020	CUP HM 516410
HCU-7162	CUP 28622
KBG-4816	CONE HM 518445
KBG-9127	CONE HM 218248
KCU-4814	CUP HM 518410
KCU-9128	CUP HM 218210
PAP806869	FTRK 505MK
PAP806870	FTRK 506MK
PAP806871	FTRK 507MK
PAP806933	CUP 382 A
PAP806934	CUP JM 515610
PAP806994	CONE 385 A
PAP806996	CONE JM 515649

TTC	
550031	6311 NR
550182	CONE 25590
550228	CUP 25821
550375	CUP 25520
550900	CONE JLM 104948
550908	6212
550927	CONE 25584
550929	CUP JM 511910
550930	CONE JM 511946
550931	CONE 2580
550978	CUP 2729
550982	6014
551006	F 17043 K
551013	CONE 25581
56-432-1X	FTRK 56-432-1X
98-432-1X	FTRK 98-432-1X
101-432-1X	FTRK 101-432-1X
101-482-1	6213 NR
312476-22X	FTRK 312476-22X
313432-10X	FTRK 313432-10X
313432-1X	FTRK 192
313432-20X	FTRK 313432-20X
313432-25X	FTRK 313432-25X
313432-30X	FTRK 313432-30X
313432-31X	FTRK 313432-31X
313432-33X	FTRK 313432-33X
313432-34X	FTRK 313432-34X
313432-35X	FTRK 313432-35X
313432-43X	FTRK 313432-43X
313432-46X	FTRK 313432-46X
313628X	CONE JLM 71949 C

4 \ Manufacturer Part Numbers

Manufacturer Parts	FERSA
Volvo	
1521452	F 17092 K
1652575	F 17095 K
1654088	F 17094 K
1656116	CONE F 15150 A
20483574	F 17105 K
20785448	F 18059
21170624	F 18053
21626057	F 15326
21626061	F 15347
21626063	F 15345
21627792	F 15348
22283632	F 15346



Handwriting practice area with horizontal dotted lines.



Handwriting practice area with horizontal dotted lines.

EXPERTS IN BEARING SOLUTIONS

EUROPE
Spain \ Zaragoza

Headquarters Tif: +34 976 333 850
fersa@fersa.com
Regional branch Tif: +34 876 269 571
fersaiberia@fersa.com

NORTH AMERICA
U.S.A \ Ohio

fersa.usa@fersa.com

ASIA
China \ Jiaxing

Tif: +86 (0) 573 8271 6335
fersa.cn@fersa.com

SOUTH AMERICA
Brazil \ Pinhais

Pinhais
Tif: +55 41 3132 5100
São Paulo
Tif: +55 11 2325 3938
fersa.brasil@fersa.com



www.fersa.com

