

FAG



**added
competence**

Fast, Quiet, Efficient: Spindle Bearings with a Polyamide Cage

New series B70..-TVP-P4

SCHAEFFLER

Fast, quiet, efficient



Figure 1: FAG spindle bearing with ball-guided polyamide cage

Significant reduction in mounting and commissioning time

FAG spindle bearings are manufactured under the highest cleanliness conditions and using state-of-the-art washing technologies. Furthermore, their quality is assured by means of 100% “end-of-line” noise testing.



Figure 2: In numerous sizes from $d = 25$ mm to $d = 100$ mm

Due to the cleanliness conditions and the preservation methods and agents applied, they can be directly greased and mounted by the end user without the need for additional intermediate cleaning processes. The use of cages guided by the rolling elements in FAG spindle bearings with the suffix P4 allows an increase of up to 30% in the speed of grease distribution.

Spindle bearings with numerous advantages

- higher limiting speeds compared to competitor products, *Figure 3*
- rapid availability
- minimal noise
- efficient in mounting and commissioning

- new ball-guided polyamide cage TVP
- data matrix code on the bearing: high level of security against counterfeit bearings
- marking of the width tolerance on the bearing and the packaging
- available in numerous sizes, *Figure 2*
- for high continuous loads.

Areas of application

- milling spindles in the medium speed range
- main spindles with external drive
- spindles in machining centres
- high speed electric motors.

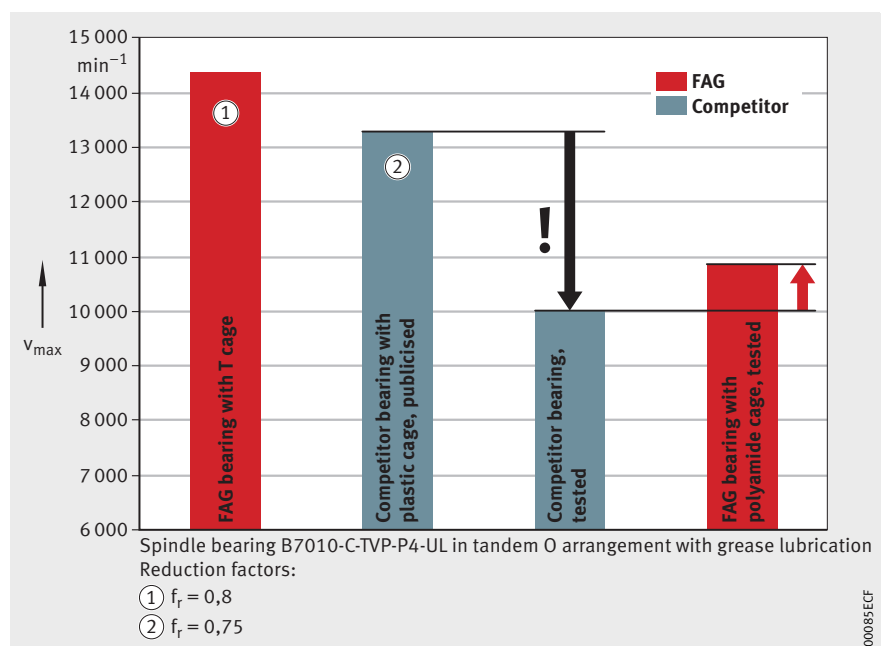

Figure 3: Comparison of speeds

Rigidity

The rigidity of a bearing set is dependent on the arrangement of the bearings and the preload. The rigidity of the complete system is determined not only by the rigidity of the bearing arrangement but also significantly by the rigidity of the shaft and housing. In the application, the rigidity can be increased by means of the mounting and operating conditions.

Axial rigidity

The axial rigidity c_a is the quotient derived from the axial load and axial displacement.

$$c_a = \frac{F_a}{\delta_a}$$

c_a	N/ μm
Axial rigidity, see <i>Dimension table</i>	
F_a	N
Axial force	
δ_a	μm
Axial displacement.	

Lift-off force

The lift-off force K_{aE} corresponds to an external axial load F_a above which the preload ceases to have an effect.

In the example, bearing 2 is relieved of load and is thus free of preload, *Figure 4*.

Speeds

Achievable speeds

The achievable speeds are dependent on the overall energy balance in the system.

The decisive factors are:

- the number of bearings
- the arrangement of the bearings
- the internal load (preload class)
- the external load
- the lubrication
- the heat dissipation.

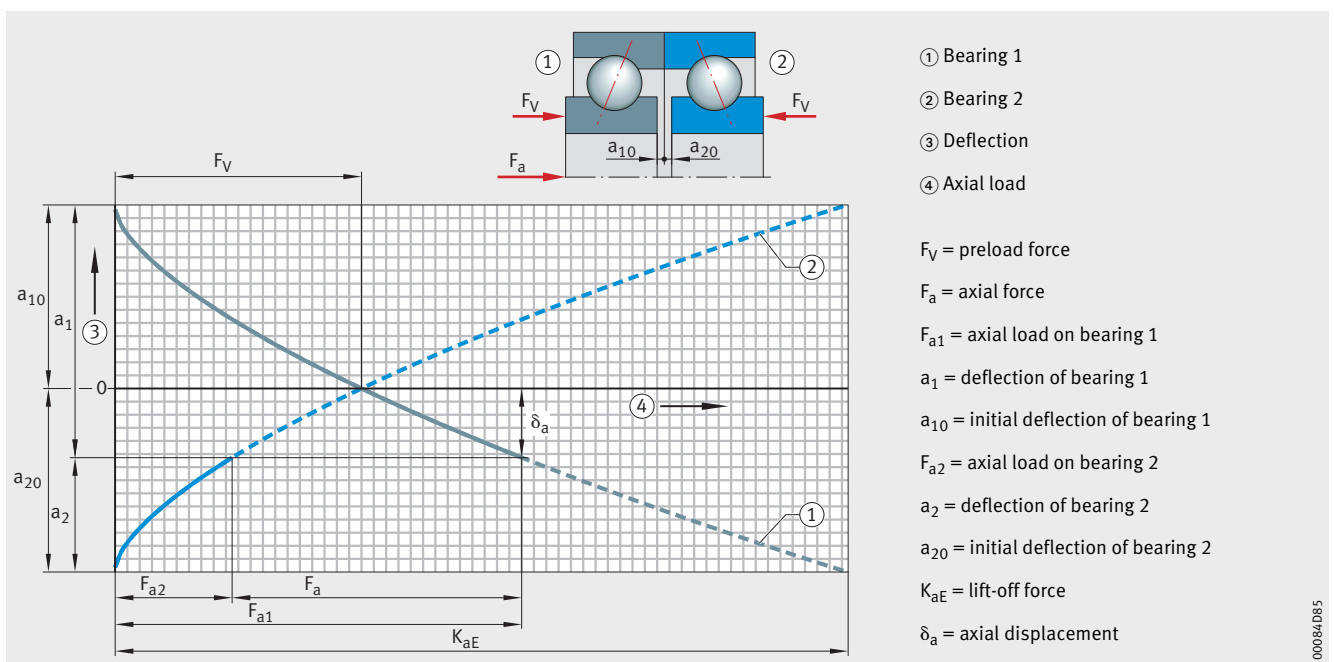

Figure 4: Preload force, axial load, lift-off force



The limiting speeds in the dimension tables are based on elastically preloaded single bearings and are guide values that may deviate up or down depending on the operating conditions. However, they give an indication of the speed capacity under relatively low load and when using elastically preloaded single bearings with good heat dissipation.

The data for grease lubrication are valid when using the correct quantity as recommended by Schaeffler of the high speed grease.

Reduction factors

The speed limits stated are reduced in the case of bearings fitted with rigid preload or high preload (in order to achieve better rigidity of the spindle) as well as in bearing pairs and bearing groups. The speeds in the dimension tables must therefore be multiplied by reduction factors. The factors f_r to be used in this case are shown in *Table 1*.



The factors indicated for speed reduction are valid for bearings with steel balls and a polyamide cage TVP for continuous operation < 5 h at constant speed. In the case of continuous operation > 5 h and grease lubrication, it is recommended that an additional reduction factor $f_r = 0,85$ is applied to these bearings.

Calculation example

$$\begin{aligned} n_{G \text{ grease}} &= 12\,000 \text{ min}^{-1} \\ n_{>5 \text{ h}} &= 12\,000 \text{ min}^{-1} \cdot 0,8 \cdot 0,85 \\ &= 8\,160 \text{ min}^{-1} \end{aligned}$$

Lubrication

Grease quantities

The individual bearing series require different grease quantities. The recommendations are matched to the space within the bearing that is not disturbed by rotating parts, see *Table 2*.

Table 1: Speed reduction for spindle bearing sets

Arrangement of bearings	Bearing preload Factor f_r
Spacing greater than twice bearing bore	
	0,85
	0,8
	0,75
Spacing 0 to bearing bore	
	0,75
	0,65
	0,65
	0,72
	0,54

Table 2: Recommended grease quantities for spindle bearings B70

Bore code	Grease quantity cm^3
05	0,86
06	1,12
07	1,74
08	2,35
09	3
10	3,3
11	4,6
12	4,95
13	5,3
14	7,1
15	7,5
16	9,65
17	10,3
18	13,3
19	13,9
20	14,6

Design of bearing arrangements

Machining tolerances of shaft and housing

Recommendations for the machining tolerances of the shaft and housing as parts adjacent to the bearing, see *Table 3* and *Table 4*.



In order to make comprehensive use of the performance capacity of spindle bearings, the adjacent construction must be of an appropriate design.

Tolerances of spindle bearings

Tolerances of the inner and outer ring in spindle bearings, see *Table 5* and *Table 6*.

Table 3: Machining tolerances of the shaft

Nominal shaft diameter		Deviation for d		Cylin- dricity	Flat- ness	Axial runout	Coaxi- ality	Mean rough- ness
d mm		μm		t_1	t_3	t_4	t_5	Ra
over	incl.			μm	μm	μm	μm	μm
25	30	3	-3	1	1	1,5	4	0,2
30	50	3,5	-3,5	1	1	1,5	4	0,2
50	80	4	-4	1,2	1,2	2	5	0,4
80	100	5	-5	1,5	1,5	2,5	6	0,4

Table 4: Machining tolerances of housing

Nominal housing bore diameter		Deviation for D				Cylin- dricity	Flat- ness	Axial runout	Coaxi- ality	Mean rough- ness
D mm		μm				t_1	t_3	t_4	t_5	Ra
over	incl.	Locating bearing		Non-locating bearing		μm	μm	μm	μm	μm
25	30	+4	-2	+8	+2	1,5	1,5	2,5	4	0,4
30	50	+4	-3	+10	+3	1,5	1,5	2,5	4	0,4
50	80	+5	-3	+11	+3	2	2	3	5	0,4
80	100	+6	-4	+14	+4	2,5	2,5	4	6	0,8

Table 5: Tolerances of inner ring (tolerance class P4)

Nominal bearing bore diameter		Deviation		Width variation	Width deviation		Variation		Radial runout	Axial runout	
d mm		Δ_{dmp}		V_{Bs}	Δ_{Bs}		out of roundness	of mean diameter	K_{ia}	S_d	S_{ia}
over	incl.	μm		μm	μm		V_{dp}	V_{dmp}		μm	μm
25	30	0	-5	2,5	0	-120	4	2,5	3	4	4
30	50	0	-6	3	0	-120	5	3	5	4	4
50	80	0	-7	4	0	-150	5	3,5	4	5	5
80	100	0	-8	4	0	-200	6	4	5	5	5

Table 6: Tolerances of outer ring (tolerance class P4)

Nominal outside diameter		Deviation		Width variation	Variation		Radial runout	Axial runout	
D mm		$\Delta_{Ds}, \Delta_{Dmp}$		V_{Cs}	out of roundness	of mean diameter	K_{ea}	S_D	S_{ea}
over	incl.	μm		μm	V_{Dp}	V_{dmp}		μm	μm
30	50	0	-6	2,5	5	3	5	4	5
50	80	0	-7	3	5	3,5	5	4	5
80	120	0	-8	4	6	4	6	5	6
120	150	0	-9	5	7	5	7	5	7

The width deviation Δ_{Cs} is identical to Δ_{Bs} of the corresponding inner ring.

Machining tolerances of spacer sleeves

Recommendations for the machining tolerances of the inner and outer spacer sleeve, see *Table 7* and *Table 8*.

Unless stated otherwise in the drawing, both spacer sleeves should be of the same length. The end faces of both sleeves should therefore be finish ground in a single clamping operation.

Table 7: Machining tolerances of inner spacer sleeve

Nominal sleeve bore diameter d_2 mm		Deviation for d_2		Cylin- dricity t_1	Axial runout t_4	Paral- lelism t_6	Radial runout t_7	Mean roughness ¹⁾ Ra
over	incl.	μm		μm	μm	μm	μm	μm
25	30	13	0	4	1,5	1,5	4	0,4
30	50	16	0	4	1,5	1,5	4	0,4
50	80	19	0	5	2	2	5	0,4
80	100	22	0	6	2,5	2,5	6	0,8

¹⁾ Including end faces.

Table 8: Machining tolerances of outer spacer sleeve

Nominal sleeve outside diameter D_2 mm		Deviation for D_2		Cylin- dricity t_1	Axial runout t_4	Parallelism t_6	Mean roughness ¹⁾ Ra
over	incl.	μm		μm	μm	μm	μm
30	50	-9	-25	4	2,5	1,5	0,4
50	80	-10	-29	5	3	2	0,4
80	120	-12	-34	6	4	2,5	0,8
120	150	-14	-39	8	5	3,5	0,8

¹⁾ Including end faces.

Bearing designation

The structure of the short designation for spindle bearings is shown in *Figure 6*.

Marking of bearings

FAG spindle bearings for machine tools have a uniform designation system on the end faces of the bearing rings, *Figure 7*.

In addition to the actual bearing designation, this also contains information as follows:

- the tolerance of the bore and outside diameter
- the width tolerance of the bearing
- the mounting position indicated by the marking on the lateral surface of the outer ring (indication of the contact angle).

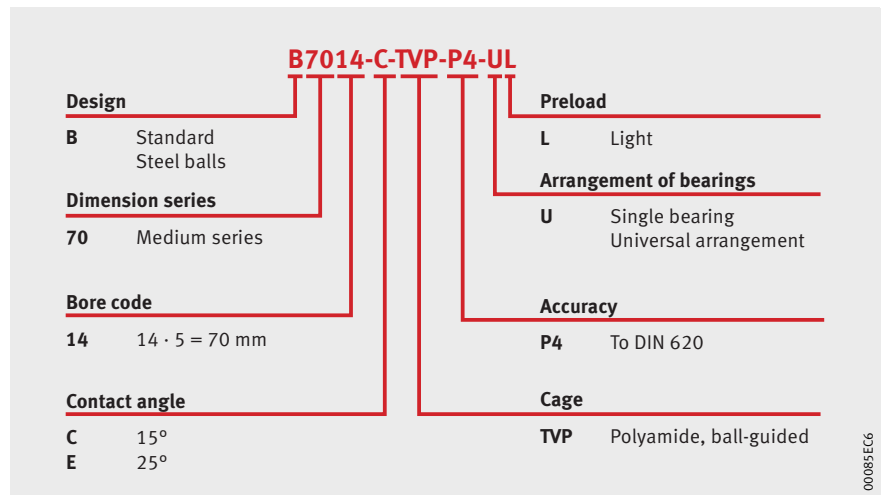

Figure 6: Bearing designation



Figure 5: High quality packaging and labelling, including marking on the end face

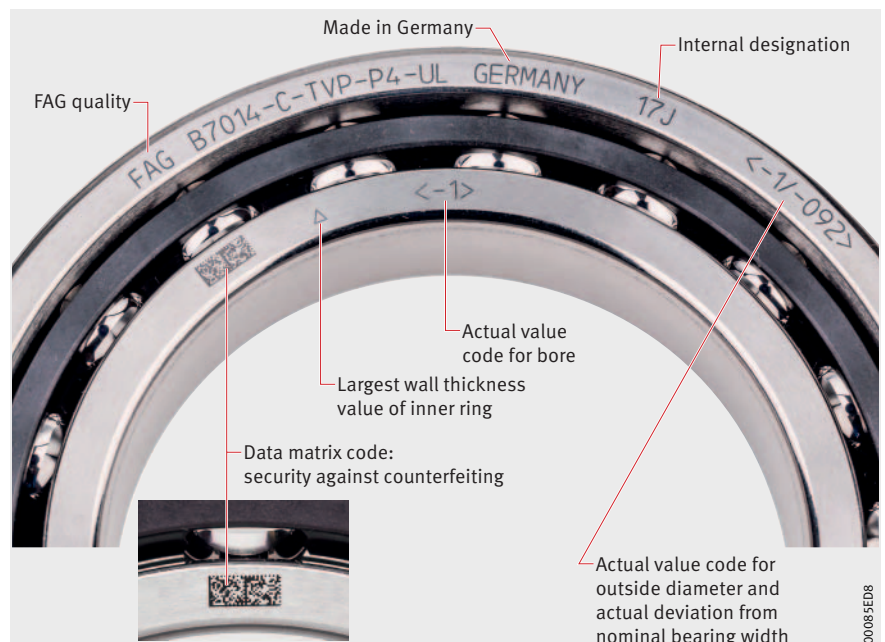
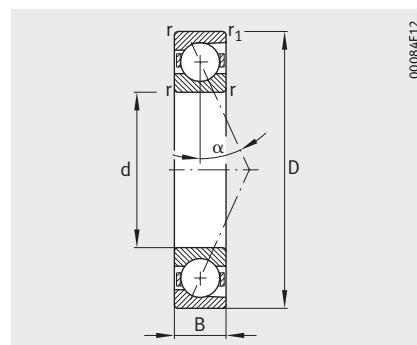

Figure 7: Marking on open spindle bearings

Spindle bearings with polyamide cage

With large size balls

Steel balls



B70

Dimension table - Dimensions in mm

Designation	Mass m ≈ kg	Dimensions				Contact angle α °	Mounting dimensions			
		d	D	B	r, r ₁ min.		d _a h12	D _a H12	r _a , r _{a1} max.	E _{tk} nom.
B7006-C-TVP-P4-UL	0,11	30	55	13	1	15	36	49	1	40,6
B7006-E-TVP-P4-UL	0,11	30	55	13	1	25	36	49	1	40,6
B7008-C-TVP-P4-UL	0,18	40	68	15	1	15	46	62	1	50,9
B7008-E-TVP-P4-UL	0,18	40	68	15	1	25	46	62	1	50,9
B7010-C-TVP-P4-UL	0,25	50	80	16	1	15	56	74	1	61,3
B7010-E-TVP-P4-UL	0,25	50	80	16	1	25	56	74	1	61,3
B7012-C-TVP-P4-UL	0,39	60	95	18	1,1	15	67	88	1,1	73,3
B7012-E-TVP-P4-UL	0,39	60	95	18	1,1	25	67	88	1,1	73,3
B7014-C-TVP-P4-UL	0,58	70	110	20	1,1	15	77	102	1,1	85,5
B7014-E-TVP-P4-UL	0,58	70	110	20	1,1	25	77	102	1,1	85,5
B7016-C-TVP-P4-UL	0,82	80	125	22	1,1	15	88	117	1,1	97,1
B7016-E-TVP-P4-UL	0,82	80	125	22	1,1	25	88	117	1,1	97,1
B7018-C-TVP-P4-UL	1,12	90	140	24	1,5	15	100	131	1,5	108,8
B7018-E-TVP-P4-UL	1,12	90	140	24	1,5	25	100	131	1,5	108,8
B7020-C-TVP-P4-UL	1,23	100	150	24	1,5	15	110	141	1,5	118,8
B7020-E-TVP-P4-UL	1,23	100	150	24	1,5	25	110	141	1,5	118,8

1) The limiting speeds in the dimension tables are based on elastically preloaded single bearings.

2) Light preload series L.

3) Minimal quantity oil lubrication.

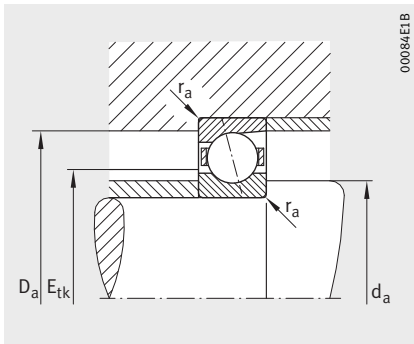

Mounting dimensions

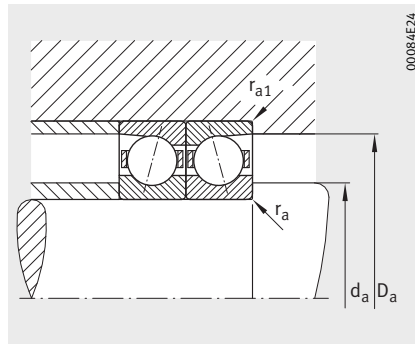

Mounting dimensions

Basic load ratings		Limiting speeds ¹⁾		Preload force ²⁾ F_v N	Lift-off force K_{aE} N	Axial rigidity c_a N/ μ m
dyn. C_r N	stat. C_{0r} N	n_G grease min^{-1}	n_G oil ³⁾ min^{-1}			
14 600	6 700	24 000	28 000	73	224	31,6
14 000	6 400	20 000	24 000	102	298	73,8
20 200	10 600	20 000	22 000	102	315	42,1
19 200	10 100	16 000	20 000	144	420	97,7
30 500	17 200	16 000	18 000	160	496	56,2
29 000	16 400	14 000	16 000	233	679	131,7
40 000	23 500	14 000	16 000	218	674	65,5
38 000	22 400	12 000	14 000	322	938	154,4
51 000	31 000	12 000	14 000	285	883	74,9
48 000	29 500	10 000	12 000	423	1 232	176,9
63 000	39 000	10 000	12 000	359	1 111	84,1
59 000	37 000	9 000	10 000	537	1 563	199,2
75 000	48 500	9 000	10 000	435	1 343	92,6
72 000	46 000	8 000	9 000	672	1 959	222,5
80 000	55 000	8 000	9 000	461	1 422	101
76 000	52 000	7 000	8 000	704	2 048	241,9

Spindle bearings with polyamide cage

With large size balls

Steel balls

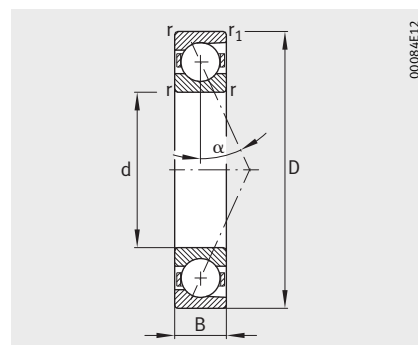

B70

Dimension table (continued) · Dimensions in mm

Designation	Mass m ≈ kg	Dimensions				Contact angle α °	Mounting dimensions			
		d	D	B	r, r ₁ min.		d _a h12	D _a H12	r _a , r _{a1} max.	E _{tk} nom.
B7005-C-TVP-P4-UL ⁴⁾	0,08	25	47	12	0,6	15	30	42	0,6	33,6
B7005-E-TVP-P4-UL ⁴⁾	0,08	25	47	12	0,6	25	30	42	0,6	33,6
B7007-C-TVP-P4-UL ⁴⁾	0,15	35	62	14	1	15	41	56	1	45,8
B7007-E-TVP-P4-UL ⁴⁾	0,15	35	62	14	1	25	41	56	1	45,8
B7009-C-TVP-P4-UL	0,21	45	75	16	1	15	51	69	1	56,3
B7009-E-TVP-P4-UL	0,21	45	75	16	1	25	51	69	1	56,3
B7011-C-TVP-P4-UL	0,36	55	90	18	1,1	15	62	83	1,1	68,5
B7011-E-TVP-P4-UL	0,36	55	90	18	1,1	25	62	83	1,1	68,5
B7013-C-TVP-P4-UL	0,42	65	100	18	1,1	15	72	93	1,1	78,2
B7013-E-TVP-P4-UL	0,42	65	100	18	1,1	25	72	93	1,1	78,2
B7015-C-TVP-P4-UL ⁴⁾	0,62	75	115	20	1,1	15	82	107	1,1	91,3
B7015-E-TVP-P4-UL ⁴⁾	0,62	75	115	20	1,1	25	82	107	1,1	91,3

¹⁾ The limiting speeds in the dimension tables are based on elastically preloaded single bearings.

²⁾ Light preload series L.

³⁾ Minimal quantity oil lubrication.

⁴⁾ Available by agreement.

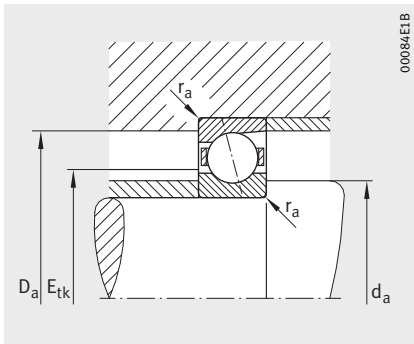

Mounting dimensions

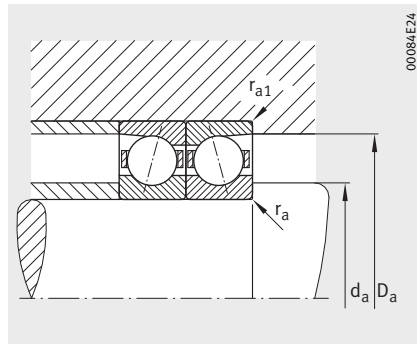

Mounting dimensions

Basic load ratings		Limiting speeds ¹⁾		Preload force ²⁾ F_v N	Lift-off force K_{aE} N	Axial rigidity c_a N/ μm
dyn. C_r N	stat. C_{0r} N	n_G grease min^{-1}	n_G oil ³⁾ min^{-1}			
13 200	5 500	28 000	34 000	66	204	27,8
12 600	5 300	24 000	28 000	94	273	64,9
19 500	9 700	22 000	24 000	101	313	38,8
17 700	8 600	18 000	22 000	136	396	87,7
25 500	13 100	18 000	20 000	133	411	48,5
24 500	12 500	15 000	18 000	202	588	106,4
37 000	20 600	15 000	17 000	203	628	59,3
35 000	19 600	13 000	15 000	299	873	139,6
39 500	23 900	13 000	15 000	215	665	65,1
37 500	22 700	11 000	13 000	316	921	153,5
50 000	31 000	11 000	13 000	279	862	74,2
48 000	29 500	9 500	11 000	423	1 232	176,9



Would you like to know more about Schaeffler bearing solutions for main spindles?

Visit our Media Library, using the search term “Super Precision Bearings” or “SP1”: <http://medien.schaeffler.com>



Your contact

Dr.-Ing. Michael Pausch

Telephone +49 9721 91-2863

michael.pausch@schaeffler.com

**Schaeffler Technologies
GmbH & Co. KG**

Georg-Schäfer-Straße 30

97421 Schweinfurt (Germany)

www.schaeffler.com

Log vCard:

Scan the QR code and load the contact data on your smartphone.

