

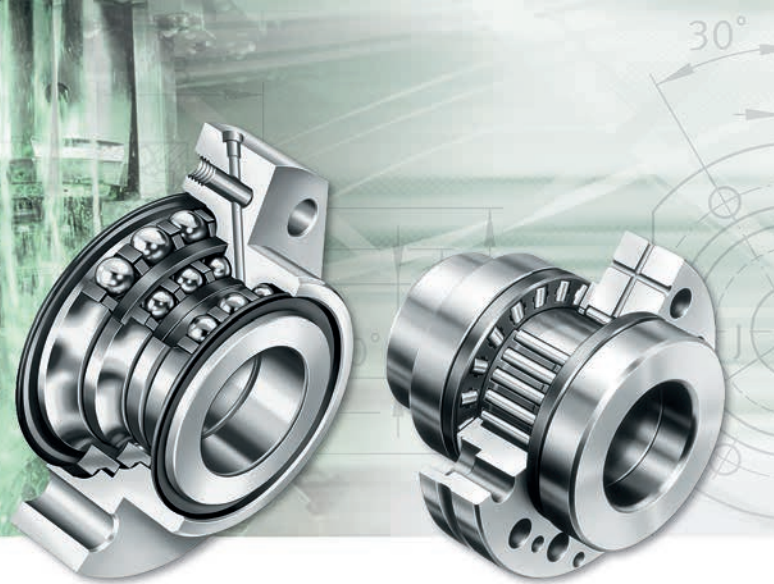

**FAG**

added  
competence



## Bearings for Screw Drives

Axial angular contact ball bearings  
Needle roller/axial cylindrical roller bearings  
Accessories

**SCHAEFFLER**





**added  
competence**

**“added competence”  
for your success**

With their forward-looking bearing arrangement solutions for feed spindles, main spindles, rotary tables and linear guidance units, INA and FAG have been at the forefront of the world market for decades. Nevertheless, bearing components alone are often no longer the decisive factor for the success of these machine subsystems.

Indeed, our customers are continuing to benefit directly from significant performance improvements and unique selling points thanks to our “ready-to-fit” products, since these follow the efficient basic concept: unpack, screw mount, use. In order to optimise the entire machine tool system, however, it is also becoming ever more important to integrate important functions such as measurement, sealing, lubrication, braking etc. in the components themselves. This intellectual approach is fulfilled comprehensively by the new concept “added competence” in the Business Unit Production Machinery since it attaches central importance to systems solution thinking for the bearing, bearing position and entire system. This means that you can now access a product range that gives optimum coverage for all your applications in the machine tool.

In addition, there is increasingly frequent usage of direct drives and mechatronic solutions in machine tools. We have therefore incorporated IDAM – INA Drives & Mechatronics – as a further strong partner in our provider network. In this way, we can now supply you from a single source with not only bearing elements but also components precisely matched to the drive system.

This opens up completely new technical and economic design possibilities for your requirements as well as significant advantages in the time and process chain.

In terms of products, we can offer you a comprehensive, precisely balanced range, precision technology and top product quality. In order to match the pulse of your developments as closely as possible, we also have a worldwide network of engineers and service and sales technicians working for you and ensuring that we maintain close contact with you in your own location.

We are therefore confident that we have the right product for you, from a robust individual component right through to the defining high end system solution.

Perhaps you would like to talk to us about this?



**added  
competence**

# Bearings for screw drives

<b>Matrix for preselection of bearings</b>	4
--	---

The application-oriented matrix allows rapid preselection of the suitable bearing.

<b>Axial angular contact ball bearings</b>	6
--	---

Axial angular contact ball bearings are precision bearings for screw drive bearing arrangements. Depending on the series, they can support radial forces as well as axial forces in one or both directions. Contact seals protect the rolling element system against contamination and moisture. For higher speeds, minimal gap seals can be used.

The bearings are available with and without fixing holes in the outer ring. Bearings with holes are screw mounted directly on the adjacent construction. This solution is particularly economical since there is then no need for the locating bore that would otherwise be required or for the bearing cover with the associated matching work.

For some areas of application, a bearing arrangement of lower precision is often sufficient. For this purpose, bearings with less stringent tolerances are available.

<b>Needle roller/axial cylindrical roller bearings</b>	100
--	-----

These precision bearings are double direction axial cylindrical roller bearings with a radial bearing component.

The bearings are available with and without fixing holes in the outer ring. Bearings with holes are screw mounted directly on the adjacent construction. The large contact surface and the small pitch of the holes allows a connection to the adjacent construction that is extremely rigid and with low tendency to settling. There is therefore no need for the bearing cover that would otherwise be required to hold the bearing, and the matching work required.

If the axial abutment of the shaft locating washer is not sufficient or a seal raceway is required, bearings with a stepped shaft locating washer extended on one side are suitable.

<b>Accessories</b>	134
--------------------	-----

Seal carrier assemblies	Seal carrier assemblies DRS are complete sealing sets that are screw mounted on the outer ring of needle roller/axial cylindrical roller bearings ZARF(L). They are precisely centred in this position and seal the bearings against external influences.
Precision locknuts	
Sockets	

BEARINX-online Easy BallScrew

Precision locknuts are used to achieve a defined axial preload in bearings for screw drives. They are also used where high axial forces must be supported and high axial runout accuracy and rigidity are required.

Calculations on screw drive bearing arrangements can be carried out free of charge using BEARINX-online Easy BallScrew.





ZKLF

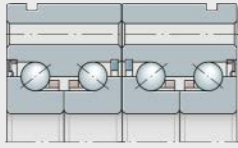

ZKLF..-2RS-2AP

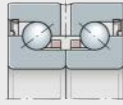

ZKLN



ZKLN..-2RS-2AP



7602, 7603,  
BSB

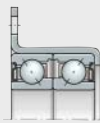

ZKLR

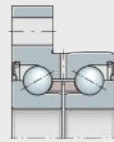

ZKLFA

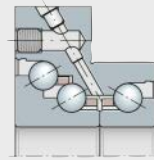

DKLFA

0008292A

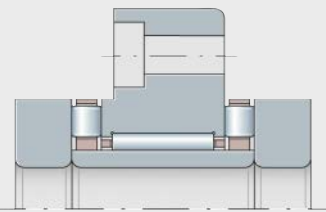

ZARF

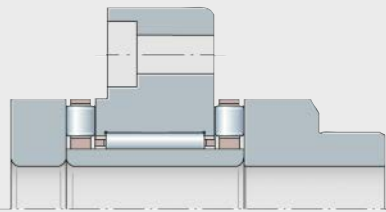

ZARF..-L

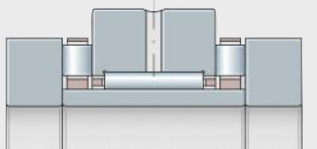

ZARN

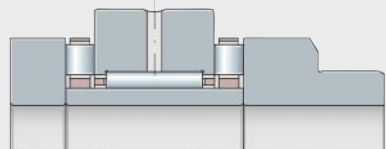

ZARN..-L

00082935

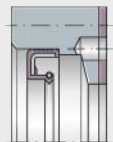

DRS

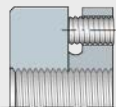

AM



ZM

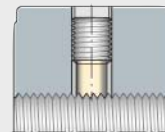

ZMA



AMS

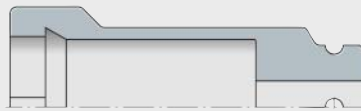

LOCKNUT-SOCKET-KM

00086074

**Matrix for preselection of bearings**

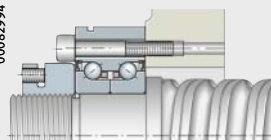
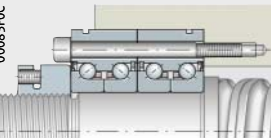
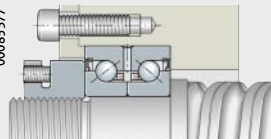
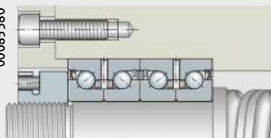
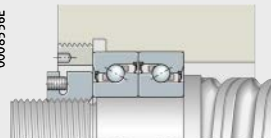
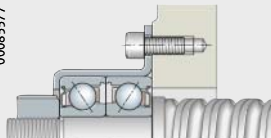
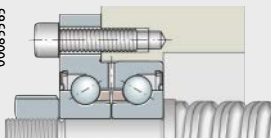
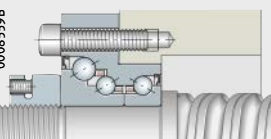
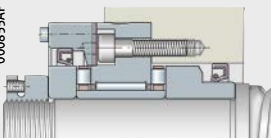
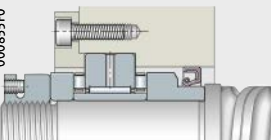
Application	Series	
<b>For standard applications</b>	 <p>00082994</p>	<p>ZKLF...-2Z ZKLF...-2RS ZKLF...-2RS-PE</p>
	 <p>00083FOC</p>	<p>ZKLF...-2RS-2AP</p>
	 <p>00085377</p>	<p>ZKLN...-2Z ZKLN...-2RS ZKLN...-2RS-PE</p>
	 <p>00085380</p>	<p>ZKLN...-2RS-2AP</p>
	 <p>0008556E</p>	<p>7602 7602...-2RS 7603 7603...-2RS BSB BSB...-2RS</p>
<b>For special applications</b>	 <p>00085577</p>	<p>ZKLR...-2Z ZKLR...-2RS</p>
	 <p>00085565</p>	<p>ZKLFA...-2Z ZKLFA...-2RS</p>
	 <p>0008559B</p>	<p>DKLFA...-2RS</p>
<b>For applications requiring very high accuracy and rigidity</b>	 <p>000855AF</p>	<p>ZARF ZARF...-L</p>
	 <p>000855F0</p>	<p>ZARN ZARN...-L</p>

**Definition of symbols**

- +++ Very good
- ++ Good
- + Satisfactory
- Adequate

**Attention!**

This selection matrix is a general overview for preliminary assessment of whether bearings can be considered for the required purpose. For the specific application, the data in the product sections and the technical principles must always be taken into consideration.

Features	Characteristics					Description, page
	High radial runout accuracy	High speeds and low friction	High rigidity and load carrying capacity	Work on adjacent construction and mounting	Low lubricant consumption	
<ul style="list-style-type: none"> <li>■ Outer ring for flange mounting</li> <li>■ Gap seals or contact seals on both sides</li> <li>■ Greased, with relubrication facility</li> <li>■ Most economical type of screw drive bearing arrangement</li> </ul>	++ ++ +	+++ ++ ++	+ + +	+++ +++ +++	++ ++ ++	13
<ul style="list-style-type: none"> <li>■ As ZKLF, but in matched pair</li> <li>■ Significantly higher load carrying capacity and rigidity than ZKLF</li> </ul>	++	++	++	++	++	15
<ul style="list-style-type: none"> <li>■ Gap seals or contact seals on both sides</li> <li>■ Greased, with relubrication facility</li> <li>■ Easier mounting than single row bearings, e.g. for plummer block housings</li> </ul>	++ ++ +	+++ ++ ++	+ + +	+ + +	++ ++ ++	16
<ul style="list-style-type: none"> <li>■ As ZKLN, but in matched pair</li> <li>■ Significantly higher load carrying capacity and rigidity than ZKLN</li> </ul>	++	++	++	+	++	17
<ul style="list-style-type: none"> <li>■ Open or sealed on both sides</li> <li>■ Highly suitable for mounting in pairs to form wide range of contact angle combinations</li> </ul>	++ ++ ++ ++ ++	+++ ++ +++ ++ +++ ++	+ + + + +	- - - - -	++ ++ ++ ++ ++	20
<ul style="list-style-type: none"> <li>■ Particularly economical alternative to solutions comprising individual ball bearings</li> <li>■ Gap seals or contact seals on both sides</li> <li>■ For applications with comparatively low loads, but high positional accuracy</li> </ul>	+ +	+++ ++	- -	+++ +++	++ ++	22
<ul style="list-style-type: none"> <li>■ Outer ring for flange mounting</li> <li>■ Stepped outer ring with flattened areas on both sides</li> <li>■ Gap seals or contact seals on both sides</li> </ul>	++ ++	+++ ++	+ +	+++ +++	++ ++	24
<ul style="list-style-type: none"> <li>■ Higher load carrying capacity on one side</li> <li>■ Outer ring for flange mounting</li> <li>■ Sealed on both sides</li> <li>■ For vertical axes</li> <li>■ For locating bearing arrangements on both sides</li> </ul>	+	++	++	+++	++	24
<ul style="list-style-type: none"> <li>■ Outer ring for flange mounting</li> <li>■ Very high accuracy, rigidity and load carrying capacity</li> <li>■ Bearing prepared for sealing</li> </ul>	+++	+	+++	+	-	103
<ul style="list-style-type: none"> <li>■ Very high accuracy, rigidity and load carrying capacity</li> <li>■ Bearing prepared for sealing</li> </ul>	+++	+	+++	-	-	104



**FAG**



## Axial angular contact ball bearings

# Axial angular contact ball bearings

		Page
<b>Product overview</b>	Axial angular contact ball bearings .....	8
<b>Features</b>	Single row and multiple row designs .....	10
	X-life .....	12
	Double row design, for screw mounting.....	13
	Double row design, not for screw mounting.....	16
	Hybrid design HC.....	18
	Single row design, suitable for any combination.....	20
	Angular contact ball bearing unit, for screw mounting .....	22
	Double row design, with flange, for screw mounting .....	24
	Triple row design, with flange, for screw mounting.....	24
	Operating temperature .....	26
	Cages.....	26
	Suffixes.....	26
	Structure and meaning of designations.....	27
<b>Design and safety guidelines</b>	Basic rating life .....	29
	Static load safety factor .....	29
	Resultant and equivalent bearing load .....	30
	Maximum radial load on screw connections for ZKLF .....	38
	Permissible static axial load for ZKLF.....	39
	Design of screw drive bearing arrangements .....	39
	Design of a locating/locating bearing arrangement.....	44
	Design of adjacent construction.....	47
	Speeds.....	51
	Friction.....	52
	Lubrication .....	53
	Mounting guidelines.....	54
	Calculation example	
	f screw drive bearing ZKLF30100-2Z-XL .....	58
<b>Dimension tables</b>	Axial angular contact ball bearings	
	For screw mounting.....	66
	For screw mounting, less stringent tolerances.....	74
	For screw mounting, matched pair.....	76
	Not for screw mounting .....	78
	Not for screw mounting, less stringent tolerances .....	82
	Not for screw mounting, matched pair .....	84
	Single direction, open .....	86
	Single direction, sealed on both sides .....	90
	Angular contact ball bearing units, for screw mounting.....	92
	Double row axial angular contact ball bearings with flange, for screw mounting.....	94
	Triple row axial angular contact ball bearings with flange, for screw mounting.....	98



# Product overview Axial angular contact ball bearings

**Double row design,  
for screw mounting**  
Lip seals or minimal gap seals

ZKLF..-2RS, ZKLF..-2Z,  
ZKLF..-2RS-PE

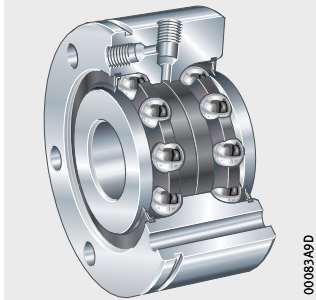

Matched pair design

ZKLF..-2RS-2AP

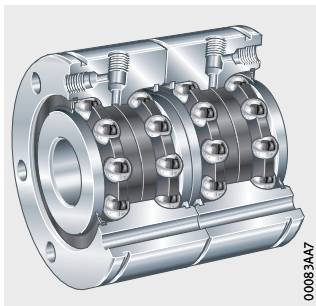

**Double row design,  
not for screw mounting**  
Lip seals or minimal gap seals

ZKLN..-2RS, ZKLN..-2Z,  
ZKLN..-2RS-PE

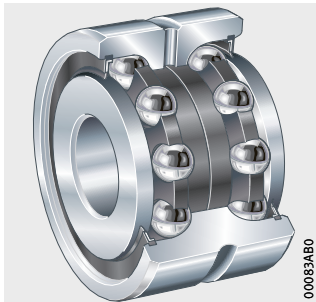

Matched pair design

ZKLN..-2RS-2AP

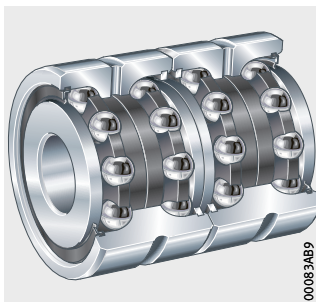

**Single row design,  
for any combination**

With or without seals

7602, 7603,  
BSB, BSB..-SU

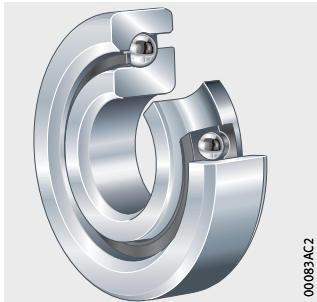

00083AC2

7602..-2RS, 7603..-2RS,  
BSB..-2RS, BSB..-2Z-SU

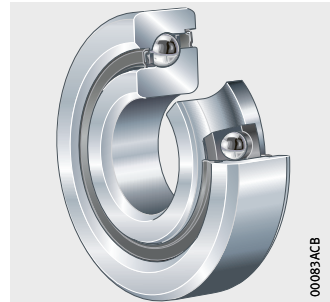

00083ACB



**Angular contact ball  
bearing unit,  
for screw mounting**

Lip seals or gap seals

ZKLR..-2RS, ZKLR..-2Z

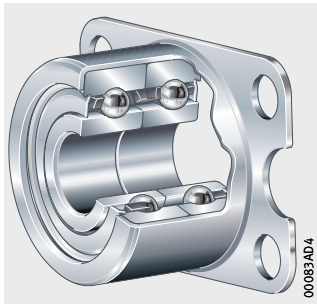

00083AD4

**Double row or  
triple row design,  
flange with flattened areas,  
for screw mounting**

Double row design,  
lip seals or minimal gap seals

ZKLFA..-2RS, ZKLFA..-2Z

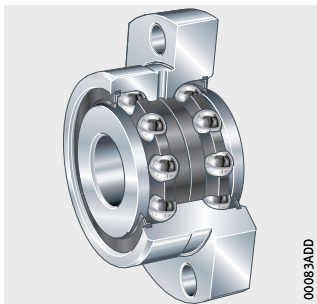

00083ADD

**Triple row design,  
lip seals**

DKLFA..-2RS

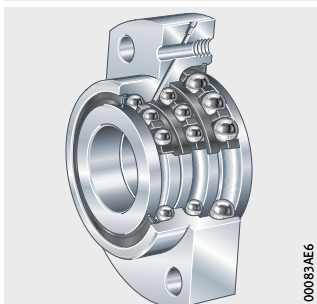

00083AE6



# Axial angular contact ball bearings

## Features

Screw drive bearing arrangements are subjected to requirements that often cannot be optimally fulfilled by the design construction of conventional bearings.

For the design of bearing arrangements that have high accuracy, high load carrying capacity, high rigidity, low friction, are easy to fit and maintenance-free or low-maintenance and are suitable for the highly dynamic operating conditions of threaded spindles, there is a wide range of INA and FAG axial angular contact ball bearings. With this product range, solutions can be found to all the technical and economic demands placed on the bearing arrangements of screw drives.

## Single row and multiple row designs

Axial angular contact ball bearings are available as single, double or triple row ready-to-fit units. They are self-retaining and comprise thick-walled, geometrically stable outer rings, ball and cage assemblies and one-piece or two-piece inner rings. In several series, the outer ring has through holes for simple flange mounting to the adjacent construction.

The bearing rings are matched to each other such that a defined preload is achieved when the rings are clamped in place using a precision locknut.

## Axial and radial load capacity

Due to the 60° contact angle, the bearings can support high axial forces as well as radial forces.

## Contact angle arrangement in X and O arrangements

In arrangements of multiple row angular contact ball bearings, a distinction is made between O, X and tandem arrangements in relation to the arrangement of contact angles. The arrangement of contact angles has an essential influence on the tilting rigidity of the bearing position, *Figure 1*, page 11, and *Figure 2*, page 11.

The characteristics of the O arrangement are:

- high tilting rigidity
- higher critical whirling speed of the threaded spindle due to the high tilting rigidity of the bearing position
- longer rating life under additional radial loads due, for example, to a belt drive

The characteristics of the X arrangement are:

- low tilting rigidity
- lower critical whirling speed of the threaded spindle
- shorter rating life under additional radial loads due, for example, to a belt drive.

Calculation example with BSB3062-SU  
 $n = 500 \text{ min}^{-1}$

$L_h$  = basic rating life  
 $\psi$  = misalignment

- ① X arrangement
- ② O arrangement

**Figure 1**  
 Identical rating life of bearings  
 in X and O arrangement  
 with misalignments between  
 bearing seat and threaded spindle

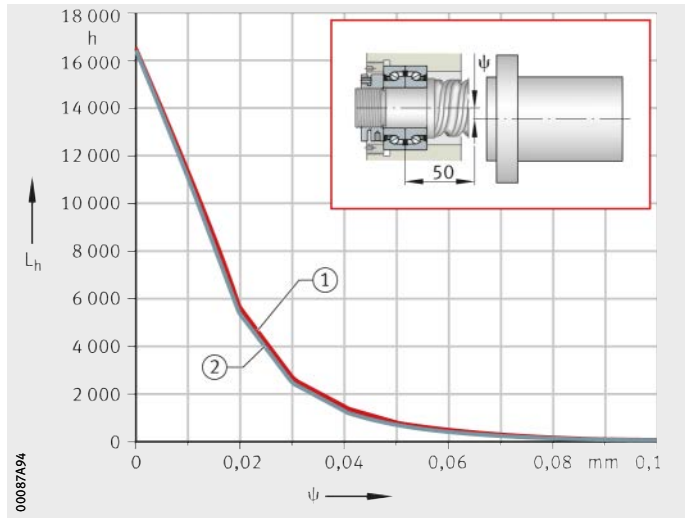

Calculation example with BSB3062-SU  
 $n = 500 \text{ min}^{-1}$

$L_h$  = basic rating life  
 $F_y$  = additional radial load due to belt drive

- ① X arrangement
- ② O arrangement

**Figure 2**  
 Longer rating life of bearings  
 in O arrangement  
 with additional radial loads

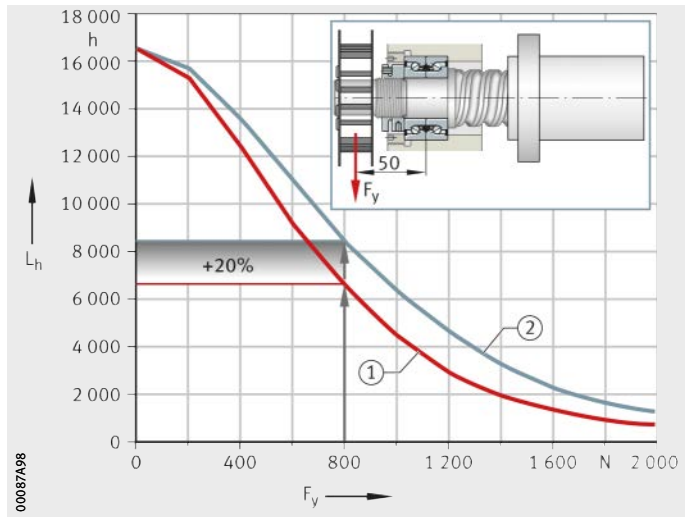

# Axial angular contact ball bearings

## X-life

Axial angular contact ball bearings ZKLF and ZKLN are supplied in the X-life design.

As a result of increased raceway accuracy and raceway quality, there is a significant reduction in the stress conditions present on the rolling elements and raceway under the same load, compared to the standard bearings. The improved quality gives reduced friction in the bearing and lower bearing temperatures; running resistance is lower, less strain is placed on the lubricant and the grease operating life and, where applicable, necessary re-lubrication intervals are extended. As a result of the lower frictional energy, there is a simultaneous increase in the energy efficiency of the bearing arrangement.

## Higher basic load ratings and limiting speeds with X-life

The basic dynamic load ratings  $C_a$  of axial angular contact ball bearings in the X-life design are 10% higher than those of the previous standard designs. This leads to a longer rating life  $L_{10}$  or can be used to allow higher loads on the bearing arrangement while achieving the same rating life.

The lower bearing friction and associated reduction in heat generation in the bearing permit significantly higher limiting speeds  $n_{G \text{ grease}}$ .

## Further information

- Reprint SSD32, Bearings for Screw Drives in X-life Quality
- Download and ordering: <http://medien.schaeffler.de>.

**Double row design,  
for screw mounting**

Axial angular contact ball bearings ZKLF are screw mounted directly on the adjacent construction or in a locating bore, *Figure 3* and *Figure 4*.

When axial angular contact ball bearings ZKLF are mounted without radial centring, *Figure 3*, the bearing is aligned in a radial direction using linear guidance systems and screw drive as a datum.

This prevents misalignments between the screw drive and bearing position. As a result, constraining forces that reduce the rating life cannot occur.

For easier dismounting of the bearings from a locating bore, the outer ring has a circumferential extraction slot, *Figure 4*.

Relubrication is facilitated by radial and axial threaded connectors with detachable grub screws.



ZKLF.-2RS  
ZKLF.-2Z  
ZKLF.-2RS-PE

① Locknut

*Figure 3*

Outer ring screw mounted  
on flat adjacent construction,  
preloaded by locknut AM

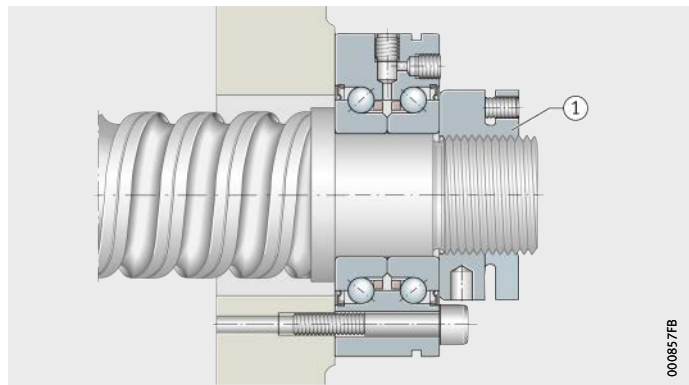

000857FB

ZKLF.-2RS  
ZKLF.-2Z  
ZKLF.-2RS-PE

① Extraction slot

*Figure 4*

Outer ring screw mounted in bore,  
preloaded by locknut AM

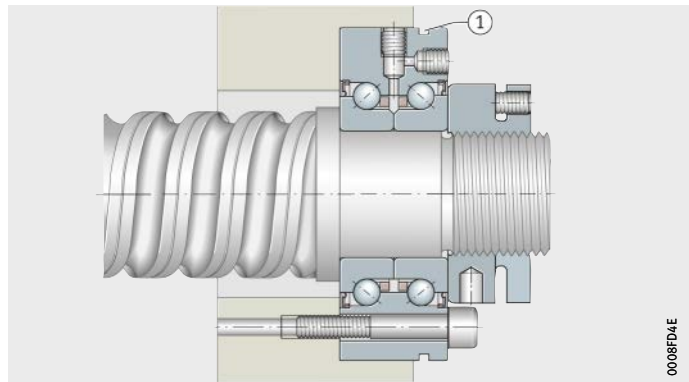

0008FD4E

**With less stringent tolerances**

Axial angular contact ball bearings ZKLF.-2RS-PE correspond to series ZKLF but have an axial runout tolerance within tolerance class 5 to ISO 492 (DIN 620-2), less stringent diameter tolerances and the suffix PE. They are used where a lower positional accuracy is acceptable. As a result, the requirement for accuracy of the adjacent construction is lower with these bearings.

**Heavy series**

Axial angular contact ball bearings ZKLF.-2RS and ZKLF.-2Z are also available in a heavy series. For the same shaft diameter, they have a larger cross-section and thus higher basic load ratings.

# Axial angular contact ball bearings

## Advantages of axial angular contact ball bearings ZKLf compared with solutions based on single bearings

The aim of the designer must be to achieve a combination of a drive spindle function with the longest possible operating life and the lowest possible overall costs.

The operating life is dependent on the correct preloading of the bearings and effective sealing. A reduction in the mechanical interfaces (the number of components) also means a reduction in possible mounting errors.

This is made possible by the use of axial angular contact ball bearings ZKLf. The bearings are supplied already correctly matched and sealed. This eliminates the need for mounting of individual bearings with its associated errors. Through flange mounting on a flat surface, alignment of the threaded spindle is a very simple process.

In the analysis of overall costs, it must also be taken into consideration that the use of single bearings involves not only the bearing costs themselves but also the following outlays, *Figure 5*:

- manufacturing costs for additional components (housing, cover)
- costs for seals
- mounting costs for the bearing unit
- costs for matching work in alignment of the spindle
- corresponding stockholding costs and logistics outlay.

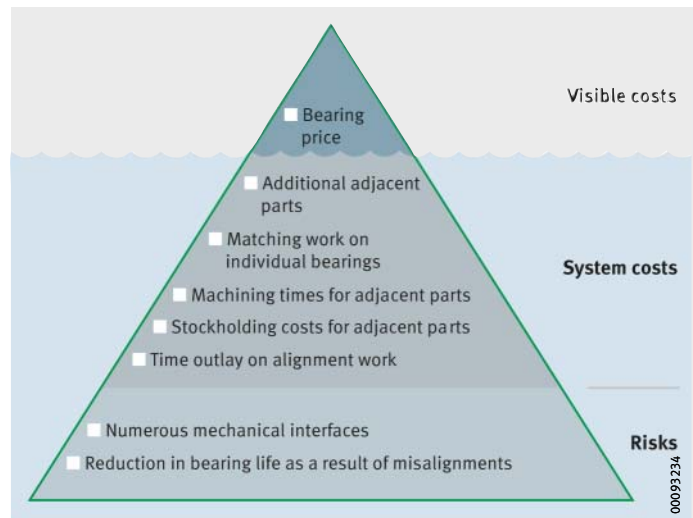

*Figure 5*  
Outlay in single bearing solutions,  
presented as an iceberg diagram

### Matched pair design

Bearings of series ZKLF..-2RS-2AP comprise a matched pair of bearings ZKLF..-2RS, *Figure 6* and *Figure 7*. The individual bearings are matched to each other.

Matched bearings have an arrow marking on the outside surface of the outer rings. When the bearings are arranged correctly, the lip seals face outwards. During fitting, the hole pattern of the two bearings must match, not the marking.

#### ZKLF..-2RS-2AP

*Figure 6*  
Matched pair,  
outer ring screw mounted in bore,  
preloaded by locknut AM

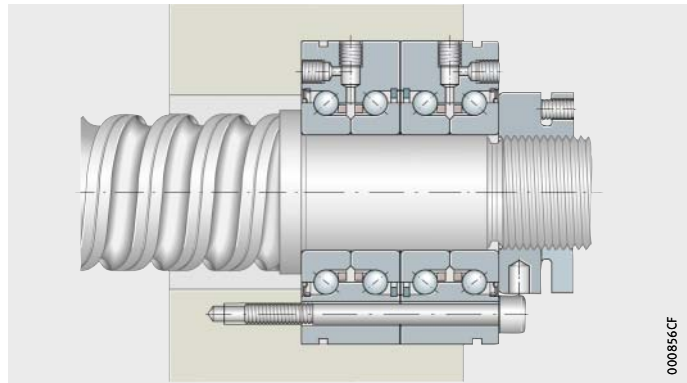

#### ZKLF..-2RS-2AP

① Support ring  
(not included in scope of delivery)

*Figure 7*  
Matched pair, screw mounted  
on face of adjacent construction,  
preloaded by locknut AM

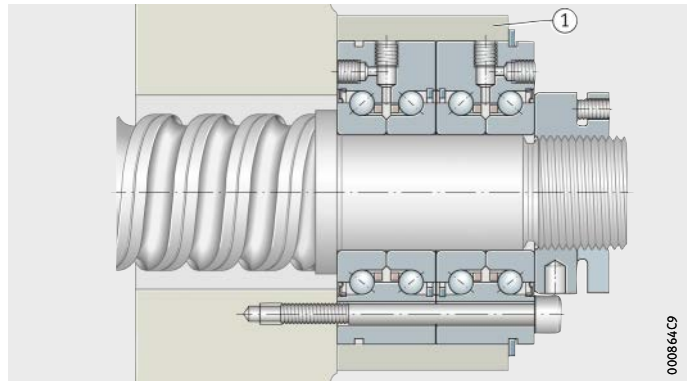

### Seals

Bearings with the suffix 2RS have lip seals and highly effective sealing.

Bearings with the suffix 2Z are sealed using minimal gap seals and are suitable for higher speeds.

### Lubrication

The bearings are greased using a lithium soap grease to GA28 and can be lubricated via the lubrication connectors in the outer ring. For the majority of applications, the initial greasing is sufficient for the whole bearing operating life.



# Axial angular contact ball bearings

## Double row design, not for screw mounting

Axial angular contact ball bearings ZKLN are mounted in a housing bore, *Figure 8* and *Figure 9*. The bearing outer ring is axially located by a ring nut or flange cover.

ZKLN..-2RS  
ZKLN..-2Z

*Figure 8*

Outer ring located by ring nut, preloaded by locknut AM

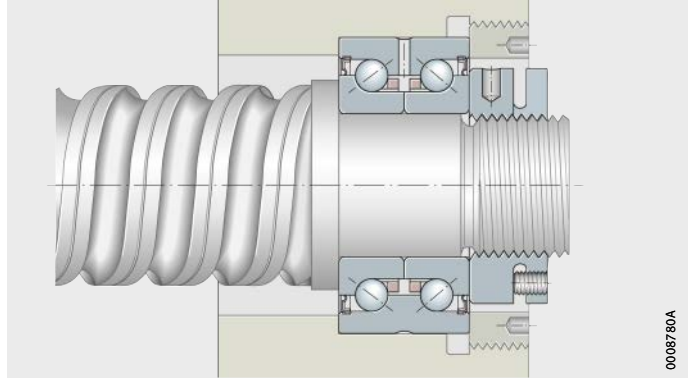

ZKLN..-2RS  
ZKLN..-2Z

*Figure 9*

Outer ring located by flange cover, preloaded by locknut AM

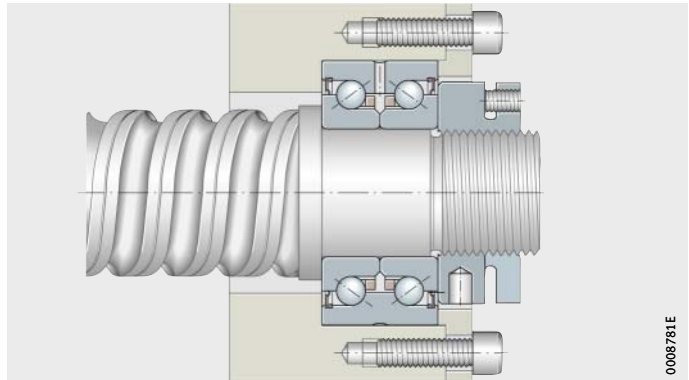

## With less stringent tolerances

Axial angular contact ball bearings ZKLN..-2RS-PE correspond to series ZKLN but have an axial runout tolerance within tolerance class 5 to ISO 492 (DIN 620-2), less stringent diameter tolerances and the suffix PE. They are used where a lower positional accuracy is acceptable. As a result, the requirement for accuracy of the adjacent construction is lower with these bearings.

## Heavy series

Axial angular contact ball bearings ZKLN..-2RS and ZKLN..-2Z are also available in a heavy series. For the same shaft diameter, they have a larger cross-section and thus higher basic load ratings.



### Matched pair design

Bearings of series ZKLN...-2RS-2AP comprise a matched pair of bearings ZKLN...-2RS, *Figure 10*. The individual bearings are matched to each other.

Matched bearings have an arrow marking on the outside surface of the outer rings. When the bearings are arranged correctly, the lip seals face outwards.

The bearing outer ring is axially located by a ring nut or flange cover, *Figure 10*.

### ZKLN...-2RS-2AP

*Figure 10*  
Matched pair,  
outer ring located by ring nut,  
preloaded by locknut AM

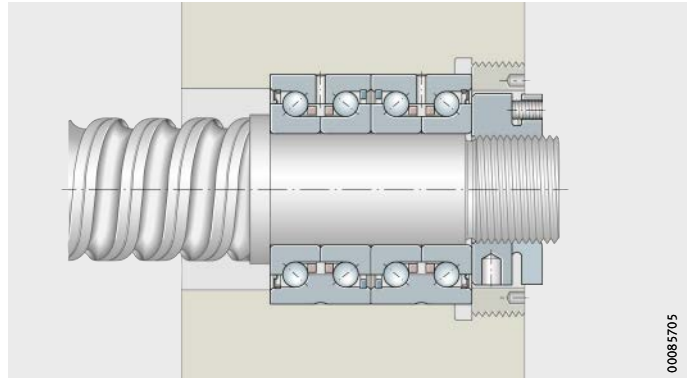

### Seals

Bearings with the suffix 2RS have lip seals and highly effective sealing.

Bearings with the suffix 2Z are sealed using minimal gap seals and are suitable for higher speeds.

### Lubrication

The bearings are greased using a lithium soap grease to GA28 and can be lubricated via a lubrication slot and lubrication holes in the outer ring. For the majority of applications, the initial greasing is sufficient for the whole bearing operating life.

The axial angular contact ball bearing ZKLN0619-2Z cannot be relubricated.

## Axial angular contact ball bearings

### Hybrid design HC



With the hybrid axial angular contact ball bearings ZKLF..-HC and ZKLN..-HC, Schaeffler offers reliable solutions to the problem of “false brinelling”, known in relation to and occasionally occurring in feed axes with ball screw drives, in which balls are thought to cause indentations in the raceways. Premature bearing failures due to this type of damage, often described as fluting, can thus be avoided.

If operating conditions are present, however, where there is insufficient relative motion between the rolling contact partners, the lubricant film at the rolling contact is interrupted and partial dry running occurs (direct steel/steel contact). Such operating conditions occur, for example, with small swivel angles, highly dynamic positional regulation or vibrations in a stationary state. This can occasionally lead, within a few hours, to premature bearing failure through false brinelling.

Ceramic rolling elements offer the possibility of permanently eliminating this harmful steel/steel contact, *Figure 11*.



*Figure 11*  
Hybrid axial angular contact  
ball bearing ZKLF..-HC

Advantages of hybrid bearings	<p>The advantages of hybrid bearings in comparison with steel bearings are:</p> <ul style="list-style-type: none"> <li>■ reliability, even in short stroke operation for long periods</li> <li>■ a three-fold increase in grease operating life</li> <li>■ higher speed capability.</li> </ul> <p>Other characteristics are as follows:</p> <ul style="list-style-type: none"> <li>■ They give the same basic rating life</li> <li>■ The fact that the basic static load ratings are approx. 30% lower is irrelevant in many screw drive applications</li> <li>■ The axial rigidity in the raceway system is only 5% lower.</li> </ul>	
Availability	<p>The following series and sizes are available as standard in the hybrid design:</p> <ul style="list-style-type: none"> <li>■ ZKLF..-2RS, ZKLF..-2Z, ZKLN..-2RS, ZKLN..-2Z</li> <li>■ bearings with d = 20 mm to 100 mm</li> <li>■ all other series and sizes can be offered by agreement with Triondur coating in order to prevent false brinelling.</li> </ul>	
Ordering example	<p>Double row axial angular contact ball bearing ZKLF with rings made from rolling bearing steel and balls made from ceramic (Hybrid Ceramic), minimal gap seals</p>	
Ordering designation	<b>ZKLF40100-2Z-HC</b>	
<b>Further information</b>	<ul style="list-style-type: none"> <li>■ Detailed information on “false brinelling” in feed axes and hybrid designs: see reprint SSD 26, Hybrid Axial Angular Contact Ball Bearings for Screw Drives</li> <li>■ Download and ordering: <a href="http://medien.schaeffler.de">http://medien.schaeffler.de</a>.</li> </ul>	

# Axial angular contact ball bearings

**Single row design,  
suitable for any combination**

The axial angular contact ball bearings 7602, 7603 and BSB are designed as universal bearings, *Figure 12* and *Figure 13*. They can be used in sets in any combination for different requirements, *Figure 13*.

**7602, 7603  
BSB**

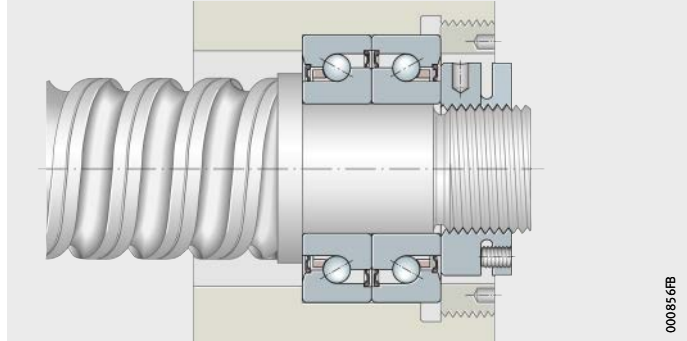

*Figure 12*  
Single row axial angular  
contact ball bearings,  
2 bearing set in X arrangement

000856FB

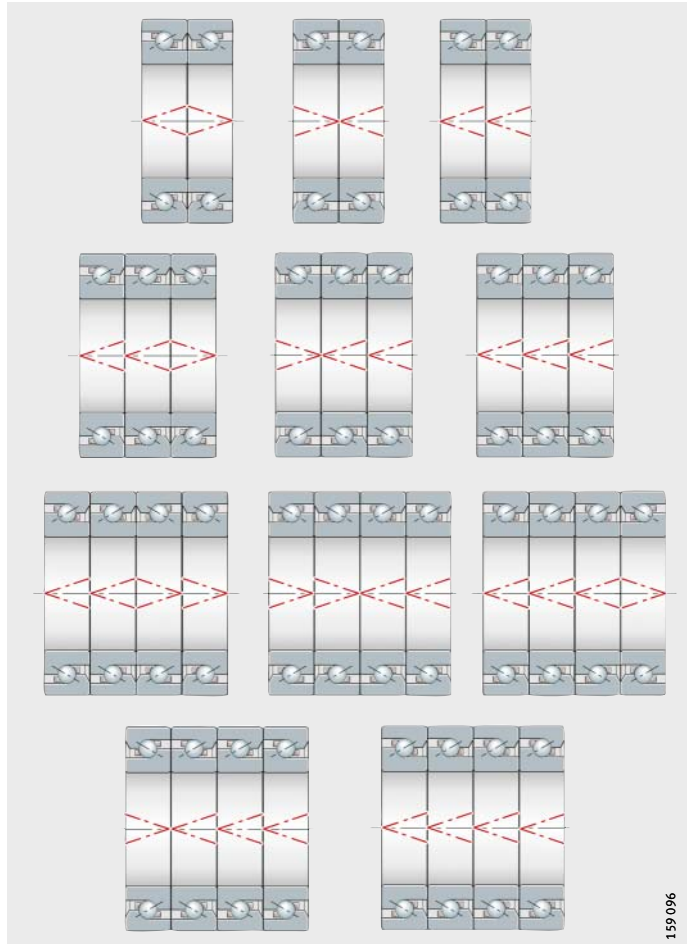

**7602, 7603  
BSB**

*Figure 13*  
Bearing set combinations

159 096

### Marking of the mounting position

The bearings have arrow marks on the outside diameter to indicate the contact angle arrangement:

- <> is an O arrangement
- >< is an X arrangement
- << is a tandem arrangement.

In bearings with seals (BSB...-2Z-SU), the contact angle can also be recognised from the seal colour after mounting:

- A brown seal on the outside indicates an O arrangement (side with high inner ring shoulder)
- A red seal on the outside indicates an X arrangement (side with low inner ring shoulder).



### Precision matched to requirements

The dimension tables contain the two axial angular contact ball bearings BSB...-T and BSB...-SU with identical dimensions. Both series differ slightly in their rolling element system. The essential difference lies in the precision of the raceways.

Axial angular contact ball bearings BSB...-T and 760 are manufactured to high requirements comparable with those of main spindle bearings. As a result, running noise is extremely low even at high speeds. These bearings are therefore used in high precision screw drive applications and in devices used in low-noise environments such as laboratories.

For applications in general machine building, for example in machine tools and handling systems, axial angular contact ball bearings BSB...-SU have adequate precision.



### Seals

Single row axial angular contact ball bearings of the basic design are not sealed.

The most common bearing sizes are also available in sealed versions:

- 760...-2RS and BSB...-2RS  
contact lip seals 2RS with minimal contact force
- BSB...-2Z-SU  
minimal gap seals 2Z.

### Lubrication

Single row axial angular contact ball bearings of the open basic design are not greased. These bearings are used in preference for applications with oil lubrication.

Alternatively, the bearings can be ordered with the suffix L055. These are greased with the high performance grease Arcanol MULTITOP and can be relubricated via the open raceway gap in the end face.

Single row, sealed axial angular contact ball bearings are greased for life with this grease.

# Axial angular contact ball bearings

## Angular contact ball bearing unit, for screw mounting

Angular contact ball bearing units ZKLR are low-cost bearings and particularly economical. They comprise a deep drawn sheet steel housing with an integral matched pair of angular contact ball bearings in an X arrangement, *Figure 14*. The housing has a Corotect coating and is thus protected against corrosion. The ball bearings are sealed on both sides by lip seals or gap seals. The bearing assembly is preloaded clearance-free.

ZKLR..-2Z  
ZKLR..-2RS

*Figure 14*  
Angular contact ball bearing unit

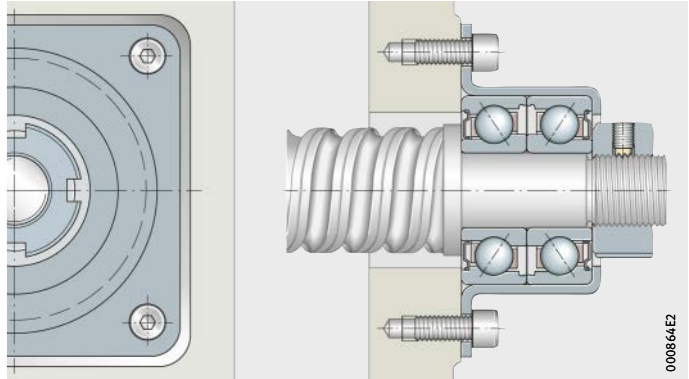

### Particularly easy to fit

The units are particularly easy to mount:

- They are directly flange mounted on the, for example, milled face of the adjacent construction. This eliminates the need for precise, costly fits and additional flange covers for seating and axial location of the bearings.
- No additional components are required for location of the bearings in the housing.
- The possible errors in mounting are reduced due to the smaller number of components compared to conventional solutions.
- They align themselves by means of the screw drive nut during mounting. This effectively eliminates any distortion due to misalignment of the bearing seats.
- They have a defined preload. There is thus no need for preloading of the bearings during mounting.
- Axially clearance-free location on the spindle is sufficient.

- Seals** Bearings with the suffix 2RS have lip seals and highly effective sealing. Bearings with the suffix 2Z are sealed using gap seals and are suitable for higher speeds.
- Lubrication** The bearings are greased for life using a lithium soap grease to DIN 51825–K2N–40.
- Operating limits** The units are highly suitable, due to their dimensions and design, for space-saving and simple bearing arrangements in highly dynamic feed screw drives.
- Areas of application include:
- inspection and measuring machines
  - small machining equipment
  - medical and laboratory equipment
  - machines in precision engineering and electronic component manufacture
  - simplification of the bearing arrangement through the use of complete units.





# Axial angular contact ball bearings

## Double row design, with flange, for screw mounting

Series ZKLFA has a stepped outer ring. It can therefore be screw mounted easily on the adjacent construction, *Figure 15*. The flange has flattened areas on both sides, so the radial design envelope in the adjacent construction can be kept very small.

ZKLFA..-2RS  
ZKLFA..-2Z

*Figure 15*  
Outer ring screw mounted on adjacent construction, preloaded by locknut ZM

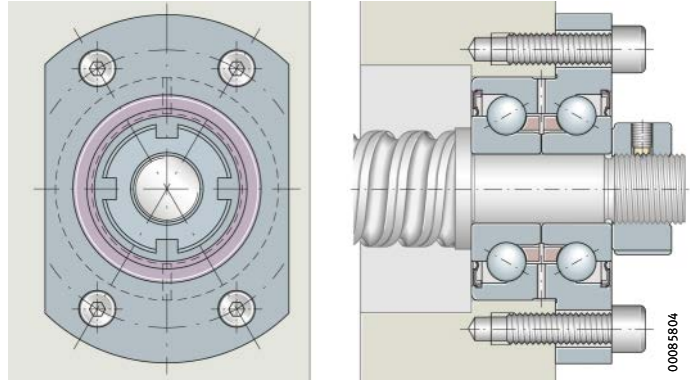

### Seals

Bearings with the suffix 2RS have lip seals and highly effective sealing. Bearings with the suffix 2Z are sealed using gap seals and are suitable for higher speeds.

### Lubrication

The bearings are greased using a lithium soap grease to GA28 and can be lubricated via a lubrication slot and lubrication holes in the outer ring. For the majority of applications, the initial greasing is sufficient for the whole bearing operating life.

The axial angular contact ball bearing ZKLFA0630-2Z cannot be relubricated.

## Triple row design, with flange, for screw mounting

Axial angular contact ball bearings DKLFA..-2RS have, in addition to two rows of balls with a contact angle of  $60^\circ$  in an O arrangement, a further row of balls, *Figure 16* and *Figure 17*. Due to this additional row, the bearings can support higher axial loads in one direction.

Due to the stepped outer ring, the bearings can be easily flange mounted on the adjacent construction. The flange has flattened areas on both sides. As a result, it requires only a small design envelope in the adjacent construction.



In order to make full use of the load carrying capacity of bearings DKLFA..-2RS, their design requires that they are subjected to continuous load in the main load direction. They are therefore used mainly in screw drives with a locating/locating bearing arrangement and tensioned spindles or in vertically arranged screw drive bearing arrangements.

For axial angular contact ball bearing units DKLFA, the locknut tightening torque must be configured in accordance with the load data.

For design of the bearing arrangement, please contact us.

**DKLFA...-2RS**

*Figure 16*  
Outer ring screw  
mounted on adjacent construction  
without radial centring,  
preloaded by locknut AM

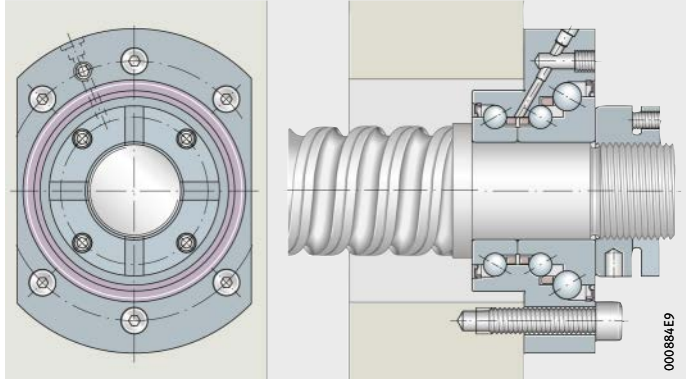

**DKLFA...-2RS**

*Figure 17*  
Outer ring screw  
mounted on adjacent construction,  
preloaded by locknut AM

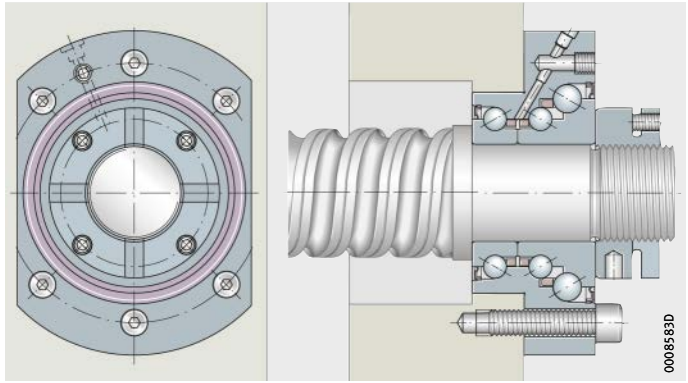

**Seals**

Triple row axial angular contact ball bearings have lip seals on both sides.

**Lubrication**

The bearings are greased using a lithium soap grease to GA28. If necessary, lubrication can be carried out via a threaded connector for central lubrication systems on the flange side.

# Axial angular contact ball bearings

## Operating temperature

Axial angular contact ball bearings are suitable for operating temperatures from  $-30\text{ }^{\circ}\text{C}$  to  $+120\text{ }^{\circ}\text{C}$ , restricted by the grease, the seal material and the plastic cages in the ball and cage assemblies.



The operating temperature influences the dynamic bearing characteristics. The values given in the dimension table are based on a room temperature of  $+20\text{ }^{\circ}\text{C}$ .

## Cages

The axial angular contact ball bearings have plastic cages. The cage design is not indicated in the suffix.

In axial angular contact ball bearings 7602, 7603 and BSB, the polyamide cages are indicated by the suffix TVP or T.

## Suffixes

Suffixes for available designs: see table.

## Available designs

Suffix	Description	Design
PE	Less stringent bearing design	Standard
T, TVP	Polyamide cage	
2AP	Axial angular contact ball bearings, matched pair (ZKLN, ZKLF)	
2RS	Contact lip seals on both sides	
2Z	Minimal gap seals on both sides	
L055	Greased with high performance grease Arcanol MULTITOP	
SU	Universal bearing; single bearings can be used in sets in any combination required	
HC	Hybrid Ceramic, rings made from rolling bearing steel, balls made from ceramic	Special design, available by agreement

## Structure and meaning of designations

The structure of the designations of axial angular contact ball bearings is specific to the series. The designation of the series is followed by indications of the bearing size and finally indications of the design variants and seals, see tables, *Figure 18* and *Figure 19*, page 28.

### Structure of designations of axial angular contact ball bearings

Feature	Indication, example	Series ①				
		ZKLF	ZKLN	ZKLFA	DKLFA	ZKLR
② Inside diameter	15	●	●	●	●	●
③ Outside diameter	30	●	●	–	–	–
Flange outside diameter	63	–	–	●	●	–
Flange height	24	–	–	–	–	●
④ Minimal gap seals	2Z	●	●	●	–	●
Lip seals	2RS	●	●	●	●	●
⑤ Standard design	–	●	●	●	●	●
Less stringent accuracy	PE	●	●	–	–	–
Two bearings in matched pair	2AP	●	●	–	–	–
With ceramic balls	HC	●	●	–	–	–

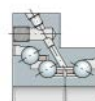

### Structure of designations of axial angular contact ball bearings (continued)

Feature	Indication, example	Series ①		
		76	BSB...-T	BSB...-SU
① ISO diameter series 2	02	●	–	–
ISO diameter series 3	03	–	–	–
② Inside diameter	25	●	●	●
③ Outside diameter	62	–	●	●
④ Without seals	–	●	●	●
Lip seals and greased with Arcanol MULTITOP	2RS	●	●	–
Minimal gap seals and greased with Arcanol MULTITOP	2Z	–	–	●
⑤ Polyamide cage	T, TVP	●	●	–
⑥ Universal single bearings suitable for use in sets in any combination required				
Single bearing	–	●	●	–
	SU	–	–	●
2 bearing set	D	●	●	●
3 bearing set	T	●	●	●
4 bearing set	Q	●	●	●
⑦ Ungreased (bearing without seals)	–	●	●	●
Bearing greased with Arcanol MULTITOP	L055	●	●	●

● Indicated in ordering designation.

# Axial angular contact ball bearings

ZKLFA1563-2RS = example,  
see table, page 27

*Figure 18*  
Structure of ordering designations  
of axial angular contact ball  
bearings ZKLF, ZKLN, ZKLFA,  
DKLFA and ZKLR

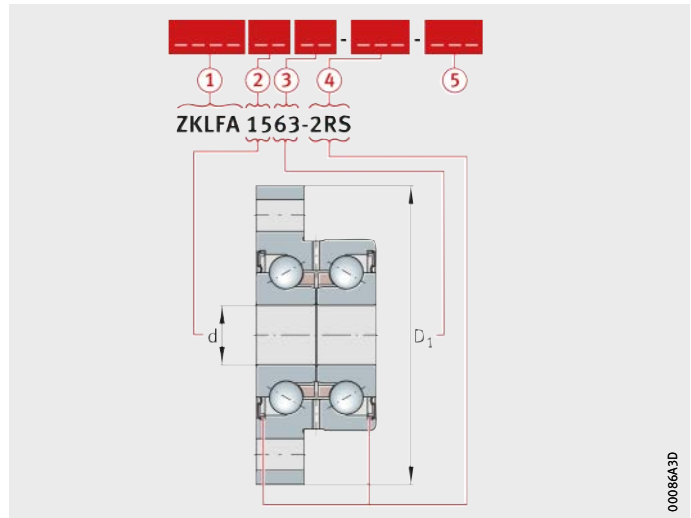

BSB025062-T = example,  
see table, page 27

*Figure 19*  
Structure of ordering designations  
of axial angular contact ball  
bearings 76, BSB...-T, BSB...-SU

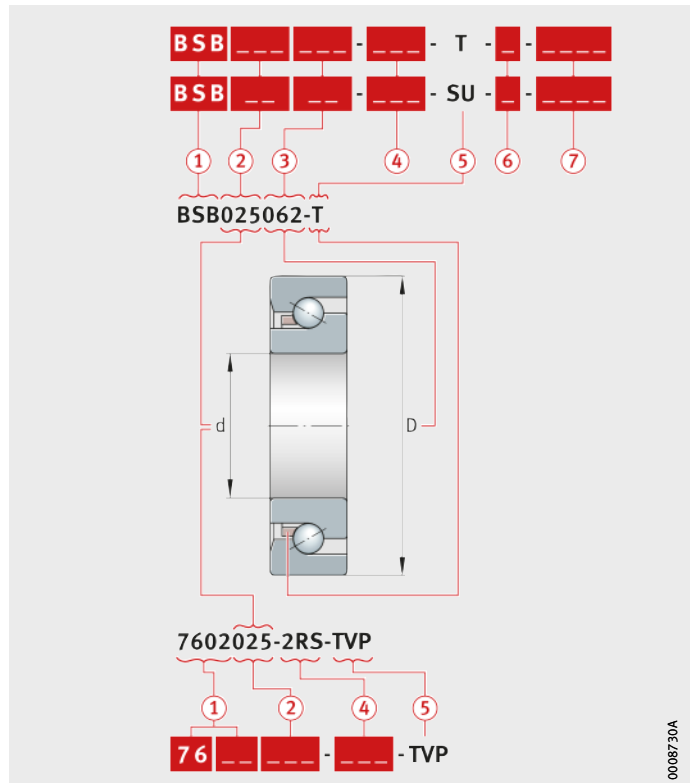

## Design and safety guidelines

### Basic rating life

The decisive factors in determining the bearing size are the basic rating life, the static load safety factor and the axial limiting load.

The rating life  $L_{10}$  or  $L_{10h}$  is calculated as follows:

$$L_{10} = \left( \frac{C}{P} \right)^p$$

$$L_{10h} = \frac{16\,666}{n} \cdot \left( \frac{C}{P} \right)^p$$

$L_{10}$  Basic rating life in millions of revolutions

$L_{10h}$  Basic rating life in operating hours

$C_r, C_a$  Basic dynamic radial or axial load rating, see dimension table

$C_r$  is valid for a contact angle  $\alpha \leq 45^\circ$ ,

$C_a$  is valid for a contact angle  $\alpha > 45^\circ$

$P$  Equivalent dynamic bearing load

$p$  Life exponent  $p = 3$

$n$  Operating speed.  $\text{min}^{-1}$



### Static load safety factor

The static load safety factor  $S_0$  indicates the security against impermissible permanent deformations in the bearing:

$$S_0 = \frac{C_0}{P_0}$$

$S_0$  Static load safety factor

$C_{0r}, C_{0a}$  Basic dynamic radial or axial load rating, see dimension table

$C_{0r}$  is valid for a contact angle  $\alpha \leq 45^\circ$ ,  $C_{0a}$  is valid for a contact angle  $\alpha > 45^\circ$

$P_0$  Maximum static load of bearing.



In machine tools,  $S_0$  should be  $\geq 4$ .

A value below this limit is only possible after analysis of the individual case. This will include a calculation study of the contact ellipse value  $k_s$ . The value describes the position of the contact ellipse in the bearing with complete ( $k_s = 1$ ) or partial support ( $k_s < 1$ ).

We recommend that the calculation should be requested from Schaeffler, stating the load and speed duty cycle.

# Axial angular contact ball bearings

## Resultant and equivalent bearing load

The resultant axial bearing load  $F_{a\ res}$  is determined from the axial operating load  $F_{aB}$  and taking account of the axial preload.

## Axial and radial operating loads

Under pure axial load,  $P = F_{a\ res}$ . If additional radial operating loads are present, P must be calculated as follows:

$$P = X \cdot F_r + Y \cdot F_{a\ res}$$

P  
Equivalent dynamic bearing load  
 $F_r$   
Radial dynamic bearing load  
 $F_{a\ res}$   
Resultant axial dynamic bearing load  
X, Y  
Radial load factor, axial load factor.

The load factors X and Y can be taken from the following table.

## Load factors X and Y

Load ratio	Load factors	
	X	Y
$\frac{F_{a\ res}}{F_r} \leq 2,17$	1,9	0,55
$\frac{F_{a\ res}}{F_r} > 2,17$	0,92	1

## Load varying in steps

In this case, P and n are calculated as follows:

$$P = p \sqrt{\frac{q_1 \cdot n_1 \cdot P_1^p + \dots + q_z \cdot n_z \cdot P_z^p}{q_1 \cdot n_1 + \dots + q_z \cdot n_z}}$$

$$n = \frac{q_1 \cdot n_1 + \dots + q_z \cdot n_z}{100}$$

P  
Equivalent dynamic bearing load  
p  
Life exponent  $p = 3$   
q  
Time proportion  
n  
Operating speed.  $\text{min}^{-1}$



**Static limiting load diagrams for ZKLR**

The easy-to-use static limiting load diagrams allow quick verification of the bearing size of angular contact ball bearing units ZKLR, as a function of the axial and radial operating load, *Figure 21*, page 32 and *Figure 22*, page 32. The decisive requirement is that the intersection between the axial and radial load must be below the limit line.

Example, *Figure 20*: If the operating loads  $F_a$  and  $F_r$  are below the limit line, the bearing size is suitable for the application.

For some angular contact ball bearing units ZKLR, equations are available instead of the diagrams, see table.



**Resultant and equivalent bearing load P for ZKLR**

Designation	Equivalent bearing load P
ZKLR0624-2Z	$P = 140 + 0,11 \cdot F_a^{1,45} + 0,012 \cdot F_r^{1,66}$
ZKLR0828-2Z	$P = 215 + 0,21 \cdot F_a^{1,32} + 0,0053 \cdot F_r^{1,74}$
ZKLR1035-2Z	$P = 240 + 0,49 \cdot F_a^{1,18} + 0,016 \cdot F_r^{1,55}$
ZKLR1244-2RS	$P = 720 + 0,34 \cdot F_a^{1,32} + 0,095 \cdot F_r^{1,54}$
ZKLR1547-2RS	$P = 550 + 0,0074 \cdot F_a^{1,55} + 0,045 \cdot F_r^{1,35}$
ZKLR2060-2RS	$P = 930 + 0,0059 \cdot F_a^{1,54} + 0,038 \cdot F_r^{1,35}$

$F_r = 600 \text{ N}$   
 $F_a = 300 \text{ N}$

The bearing is suitable in static terms since the intersection  $F_a/F_r$  is below the limit line.

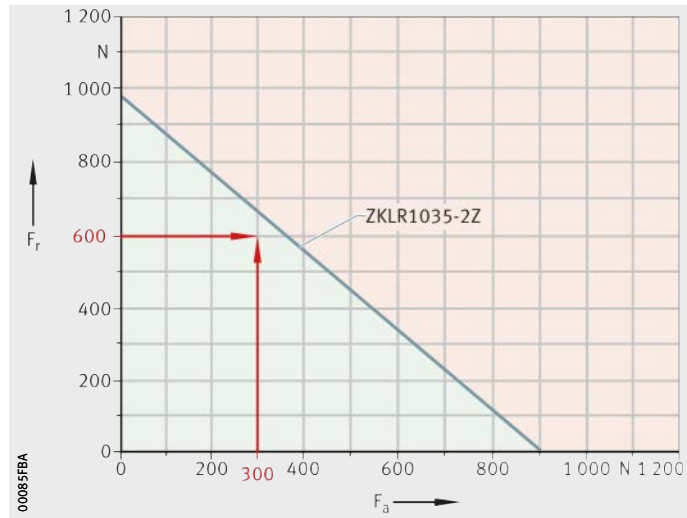
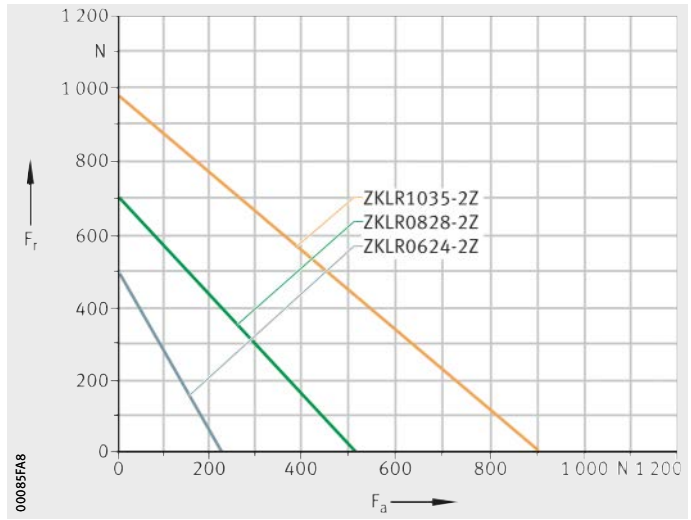

*Figure 20*  
 Static limiting load diagram, example ZKLR1035-2Z

# Axial angular contact ball bearings

$F_r$  = radial load  
 $F_a$  = axial load

*Figure 21*  
 Static limiting load diagram  
 for ZKLR...-2Z



$F_r$  = radial load  
 $F_a$  = axial load

*Figure 22*  
 Static limiting load diagram  
 for ZKLR...-2RS

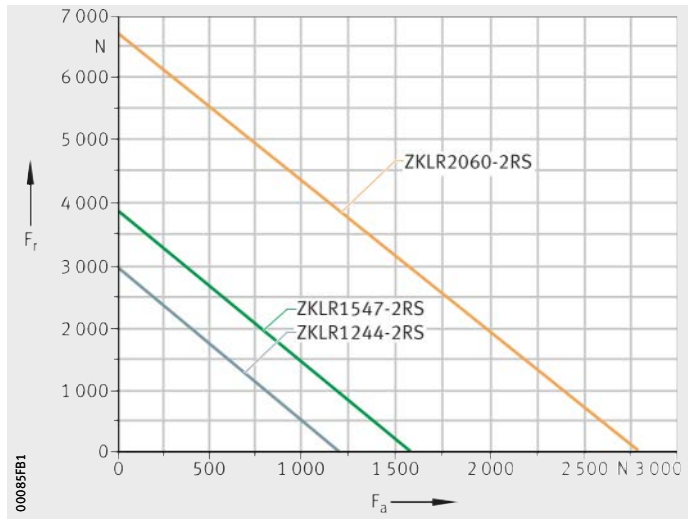

**Resultant and equivalent bearing load P for ZKLN, ZKLF, ZKLFA, DKLFA, BSB, 7602, 7603**

The bearings are axially preloaded to a defined value if the recommended precision locknuts are used and the correct nut tightening torque is applied. The resultant axial bearing load  $F_{a\ res}$  is determined from the axial operating load  $F_{aB}$  and taking account of the axial preload, *Figure 23* to *Figure 34*, page 37. For 7602, 7603 and BSB, the diagrams for  $F_{a\ res}$  are based on two-bearing sets in an O or X arrangement, see page 20. For other set combinations, please contact us.



A load in excess of the limiting load will cause the rolling element without load to lift off the raceway, in which case the bearing is no longer under preload. As a result, slippage will occur during highly dynamic acceleration events, which will lead to wear. Based on experience, the effect is less pronounced in the case of ball bearings and is therefore non-critical.

For extreme moment loads and statically overdefined systems (locating/locating bearing arrangements), please contact us. The calculation program BEARINX can give a precise design in this case, see page 154.



$F_{aB}$  = operating load  
 $F_{a\ res}$  = resultant bearing load  
 $\circ$  = limiting load

*Figure 23*  
 Resultant bearing load for ZKLN and ZKLFA, up to  $d = 10\text{ mm}$

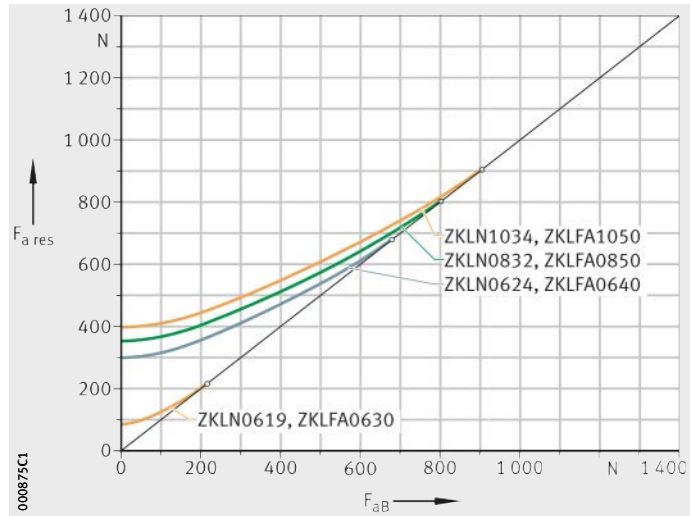

# Axial angular contact ball bearings

**Example** (red line):  
 Axial angular contact ball bearing ZKLN1545  
 $F_{aB} = 1500 \text{ N}$   
 $F_{a \text{ res}} \approx 1750 \text{ N}$   
 Loading by operating load and preload

$F_{aB}$  = operating load  
 $F_{a \text{ res}}$  = resultant bearing load  
 $\circ$  = limiting load

**Figure 24**  
 Resultant bearing load for ZKLN, ZKLF and ZKLFA, up to  $d = 17 \text{ mm}$

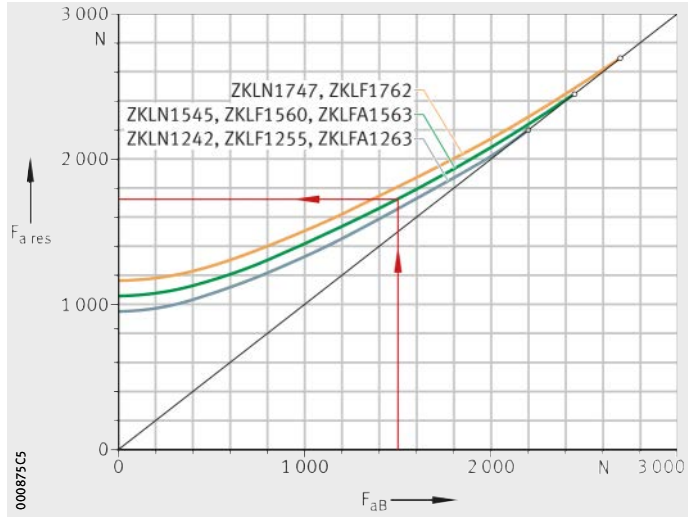

$F_{aB}$  = operating load  
 $F_{a \text{ res}}$  = resultant bearing load  
 $\circ$  = limiting load

**Figure 25**  
 Resultant bearing load for ZKLN, ZKLF, from  $d = 20 \text{ mm}$  to  $50 \text{ mm}$

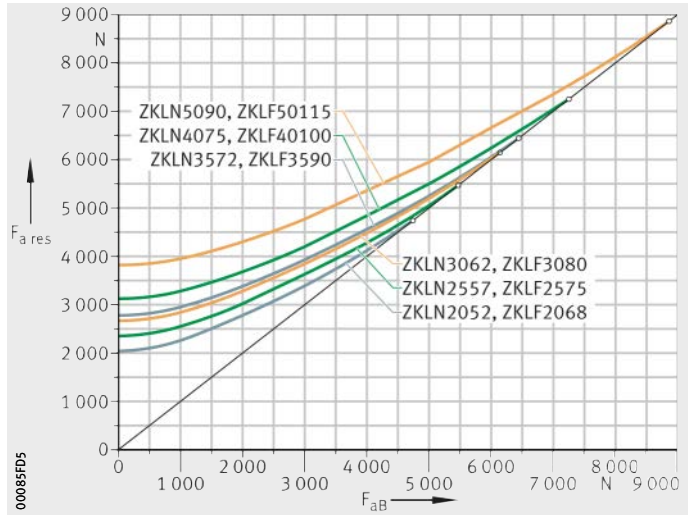

$F_{aB}$  = operating load  
 $F_{a \text{ res}}$  = resultant bearing load  
 $\circ$  = limiting load

**Figure 26**  
 Resultant bearing load for ZKLN, ZKLF, heavy series

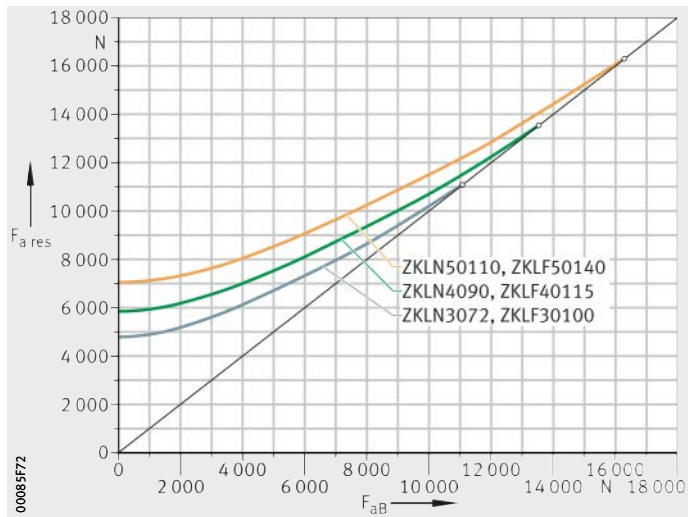

$F_{aB}$  = operating load  
 $F_{a\text{res}}$  = resultant bearing load  
 $\circ$  = limiting load

**Figure 27**  
 Resultant bearing load  
 for ZKLN, ZKLF,  
 from  $d = 60$  mm

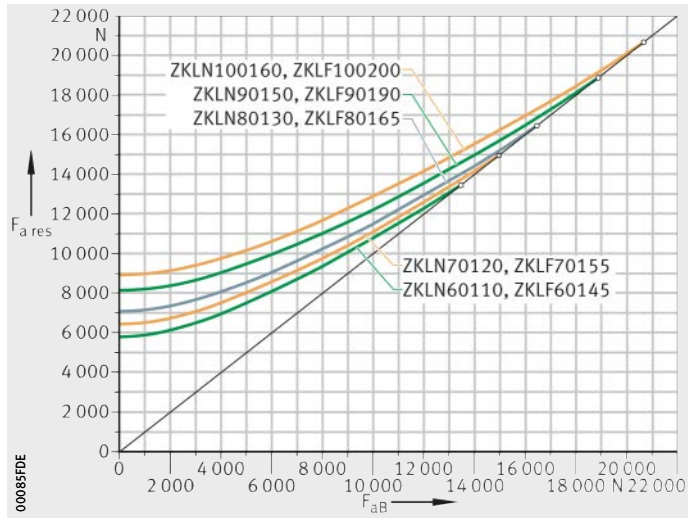

$F_{aB}$  = operating load  
 $F_{a\text{res}}$  = resultant bearing load  
 $\circ$  = limiting load

**Figure 28**  
 Resultant bearing load  
 for ZKLF,  
 $d = 100$  mm

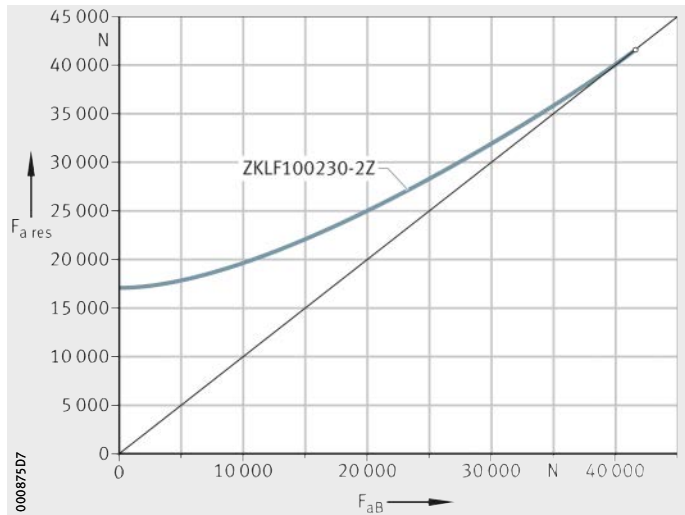

$F_{aB}$  = operating load  
 $F_{a\text{res}}$  = resultant bearing load  
 $\circ$  = limiting load

**Figure 29**  
 Resultant bearing load  
 for ZKLN...2AP and ZKLF...2AP

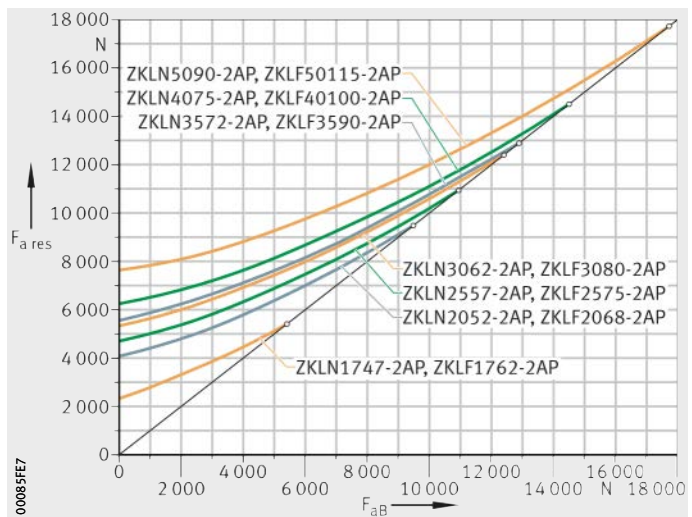

# Axial angular contact ball bearings

$F_{aB}$  = operating load  
 $F_{a\ res}$  = resultant bearing load  
 $\circ$  = limiting load

**Figure 30**  
 Resultant bearing load  
 for BSB...-T

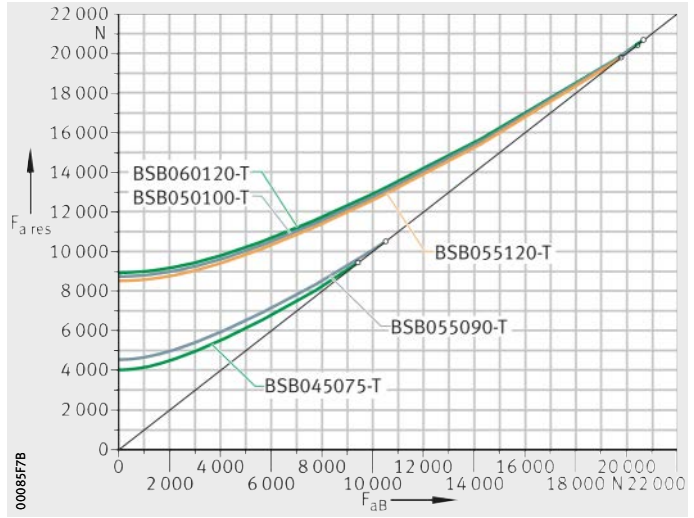

$F_{aB}$  = operating load  
 $F_{a\ res}$  = resultant bearing load  
 $\circ$  = limiting load

**Figure 31**  
 Resultant bearing load  
 for BSB...-SU

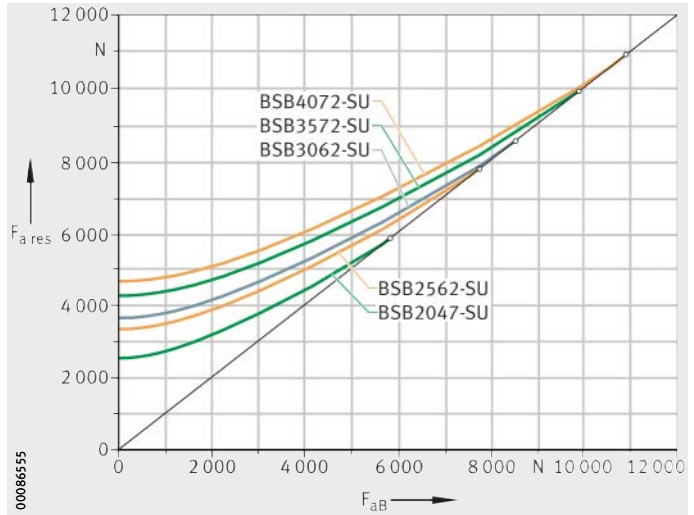

$F_{aB}$  = operating load  
 $F_{a\ res}$  = resultant bearing load  
 $\circ$  = limiting load

**Figure 32**  
 Resultant bearing load  
 for 7602012 to 7602045

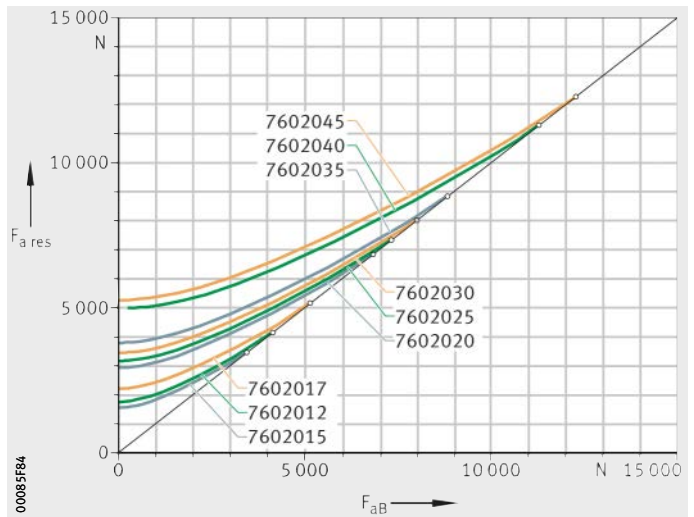

$F_{aB}$  = operating load  
 $F_{a\text{ res}}$  = resultant bearing load  
 $^\circ$  = limiting load

**Figure 33**  
 Resultant bearing load  
 for 7602050 to 7602060

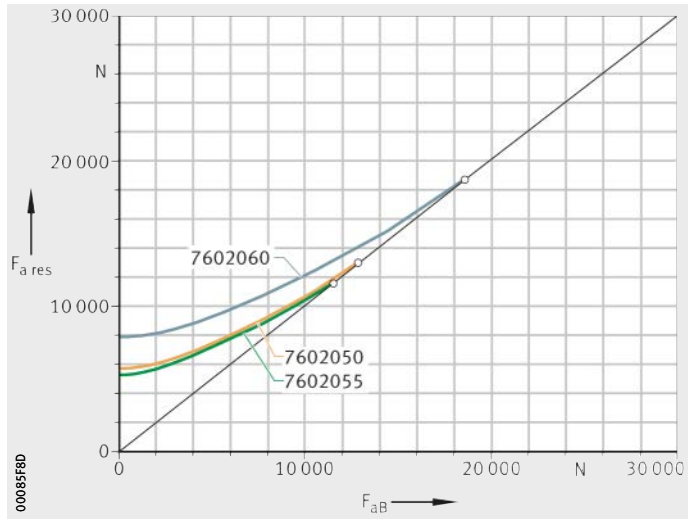

$F_{aB}$  = operating load  
 $F_{a\text{ res}}$  = resultant bearing load  
 $^\circ$  = limiting load

**Figure 34**  
 Resultant bearing load  
 for 7603020 to 7603065

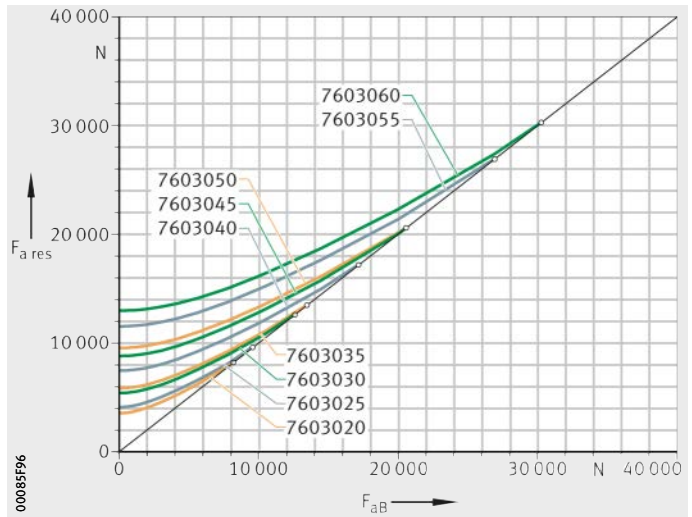

# Axial angular contact ball bearings

## Maximum radial load on screw connections for ZKLF

If bearings of series ZKLF are screw mounted on a flat adjacent construction, the maximum radial load that can be supported by the screw connections must be taken into consideration.

If the screws used are to DIN EN ISO 4762 as stated in the dimension tables, the maximum radial load that can be supported before the outer ring moves, in the case of dry components, is restricted to  $\approx 0,1 \times C_{0a}$ . If the outer ring is additionally bonded in place using, for example, Loctite 638, the maximum radial load that can be supported increases to approx.  $\approx 0,5 \times C_{0a}$ .

## Influence of the rolling element set on permissible radial loads

If the maximum radial loads that can be supported (without any axial load content) are considered in relation to the rolling element set, it can be seen that:

- With a static load safety factor of  $S_0 \geq 4$  as required for machine tools, the load that can be supported by the screw connections of the outer ring is in any case greater than the radial load restricted by the rolling element set.
- This means that (at least in theory) radial loads can be supported that, in relation to the rolling element set, will lead to a static load safety factor of  $S_0 \leq 1$  (incipient plastic deformation of rolling elements), if the outer ring is additionally bonded in place.
- This means that, under normal design criteria and with the decisive static load safety factor for the corresponding areas of application (e.g.  $S_0 = 4$  for machine tools), the rolling element set is always the decisive criterion.



## Permissible static axial load for ZKLF

For axial angular contact ball bearings ZKLF, the permissible static axial load in the direction of the screw connections, *Figure 35*, is defined as follows:

$$P_{0\text{ per}} \leq \frac{C_{0a}}{2}$$

$P_{0\text{ per}}$  N  
Permissible static axial load

$C_{0a}$  N  
Basic static axial load rating  $C_{0a}$ , see dimension tables.

ZKLF

*Figure 35*  
Static axial load in the direction of the screw connections

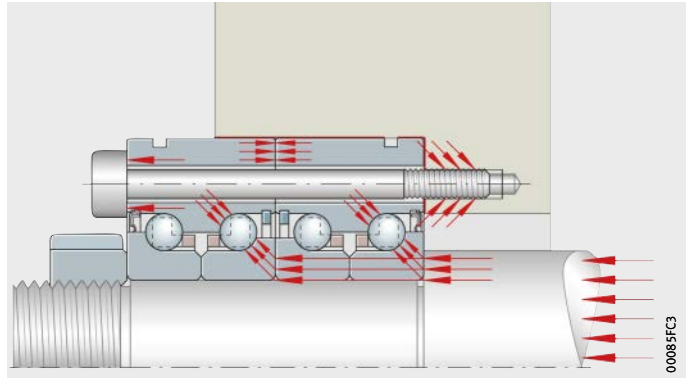

## Design of screw drive bearing arrangements

For screw drive bearing arrangements, a distinction is made between two design principles, a screw drive with a rotating spindle and a screw drive with a rotating nut. The type of bearing arrangement has an influence on the critical whirling speed, *Figure 36*.

Calculation example:  
diameter of threaded spindle = 40 mm  
spindle length = 2 000 mm

X = X arrangement  
O = O arrangement

- ① Critical whirling speed, calculated
- ② Locating/non-locating bearing arrangement
- ③ Locating/locating bearing arrangement

*Figure 36*  
Effect of bearing arrangement on critical whirling speed

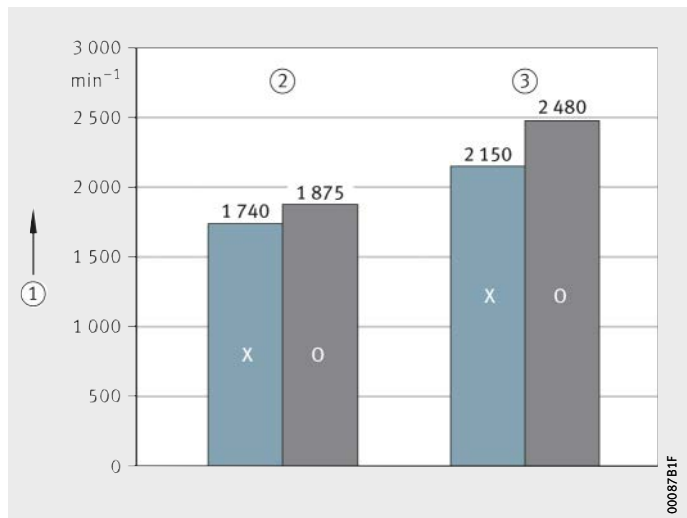

# Axial angular contact ball bearings

## Screw drive rigidity

The axial overall rigidity of the screw drive is of decisive importance for the machining accuracy and performance capability of machine tools. The axial system rigidity of a screw drive is heavily influenced by the design layout.

The highest axial system rigidity is achieved with the design “rotating screw drive nut”. In the design “rotating threaded spindle”, a significantly higher axial system rigidity is achieved with a locating/locating bearing arrangement on both sides and with increasing spindle length than with a locating/non-locating bearing arrangement, *Figure 37*.

- ① Axial overall rigidity
- ② Axial position of screw drive nut
- ③ Locating/locating bearing arrangement
- ④ Locating/non-locating bearing arrangement

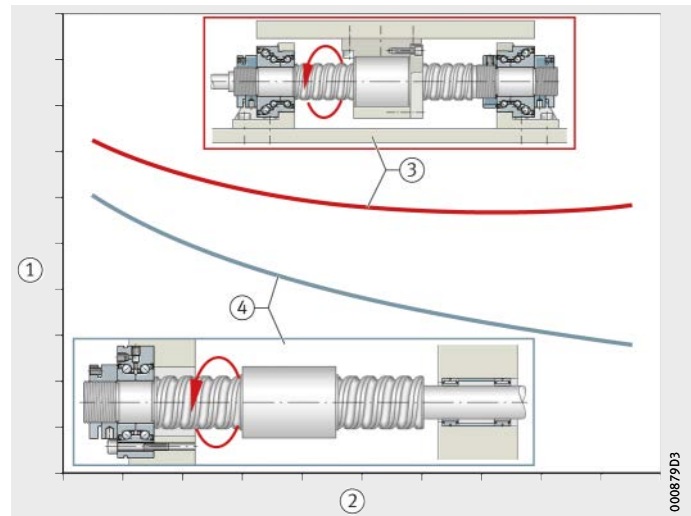

*Figure 37*

Axial overall rigidity

## Locating bearing arrangement on one side

Locating bearing arrangement on one side for rotating threaded spindle, *Figure 38*:

- for short threaded spindles
- preconditions for use with longer threaded spindles:
  - low demands on axial system rigidity
  - sufficiently high critical whirling speed.

- ① Rotating threaded spindle

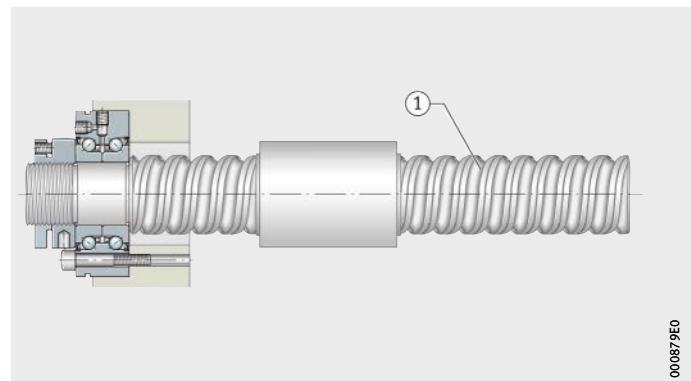

*Figure 38*

Locating bearing arrangement on one side

**Locating/non-locating bearing arrangement**

Locating/non-locating bearing arrangement for rotating threaded spindle, *Figure 39*:

- for longer threaded spindles
- low demands on axial system rigidity
- sufficiently high critical whirling speed of the threaded spindle
- if the tilting rigidity on the locating bearing side is increased by means of a second bearing, an increase in the critical whirling speed of the threaded spindle can be achieved in this bearing arrangement, *Figure 40*. As non-locating bearings, deep groove ball bearings or needle roller bearings are normally used.

① Rotating threaded spindle

*Figure 39*  
Locating/non-locating bearing arrangement

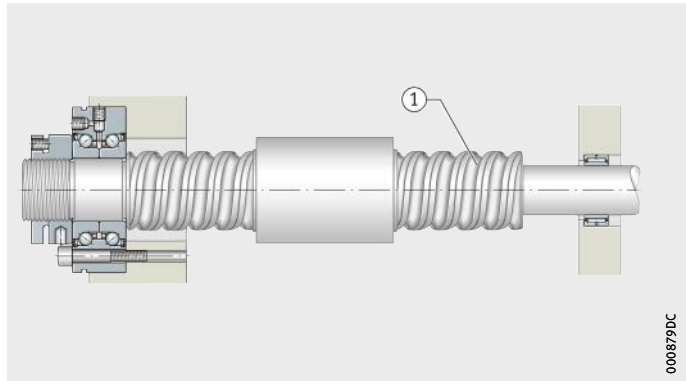

① Rotating threaded spindle

*Figure 40*  
Locating/non-locating bearing arrangement, higher tilting rigidity on non-locating bearing side

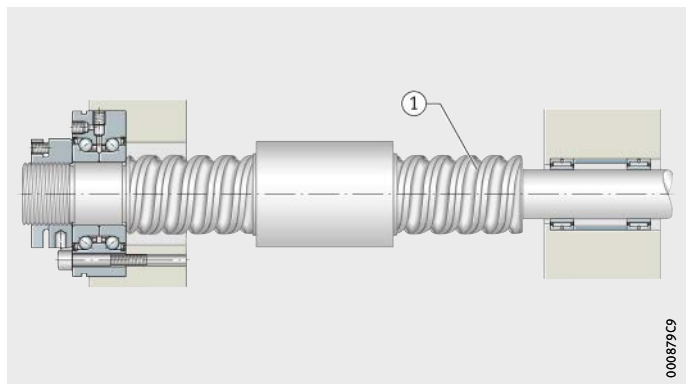

000879DC

000879C9

# Axial angular contact ball bearings

## Locating/locating bearing arrangement

Locating/locating bearing arrangement for rotating threaded spindle, *Figure 41* and *Figure 42*:

- for medium length and long threaded spindles
- high axial system rigidity, *Figure 37*, page 40
- high critical whirling speed of the threaded spindle
- little effect of length changes under heating on the positioning.

Spindle firmly clamped on both sides with rotating screw drive nut, *Figure 43* and *Figure 44*, page 43:

- for long threaded spindles
- for highly dynamic screw drives
- increased spindle tensioning possible
- no influence of spindle tensioning on the bearing rating life.

- ① Rotating threaded spindle
- ② Locknut for preloading of bearing on left side
- ③ Locknut for tensioning of threaded spindle
- ④ Locknut for preloading of bearing on right side

*Figure 41*  
Locating/locating bearing arrangement, tensioned spindle, adjustment using locknut

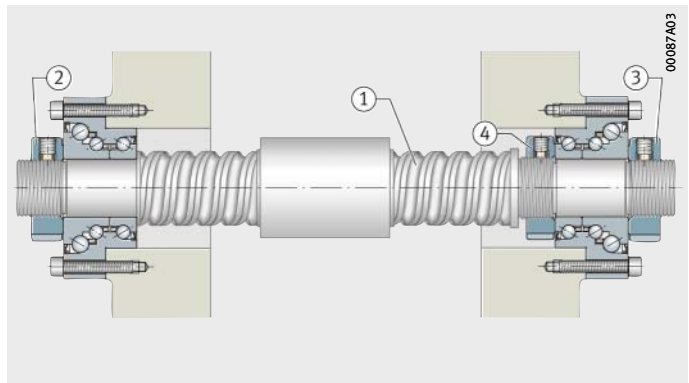

- ① Rotating threaded spindle
- ② Locknut for preloading of bearing on left side
- ③ Locknut for tensioning of threaded spindle
- ④ Shim

*Figure 42*  
Locating/locating bearing arrangement, tensioned spindle, adjustment using shim

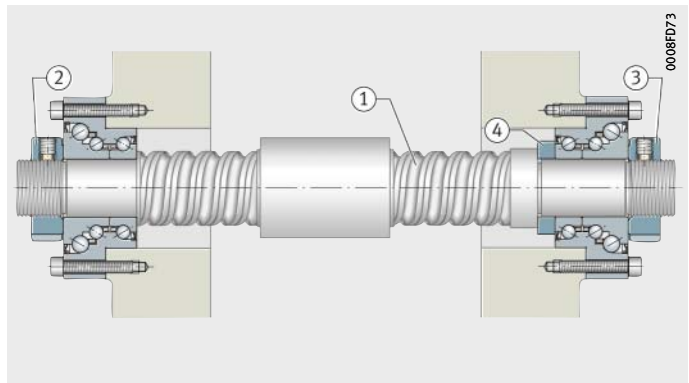

① Rotating screw drive nut

*Figure 43*  
Design example,  
rotating screw drive nut,  
tensioned spindle

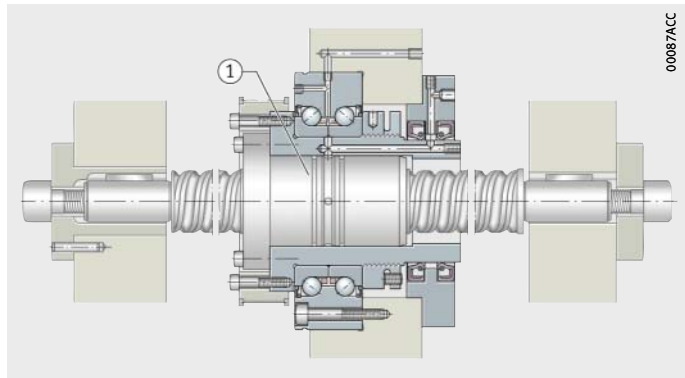

- ① Motor with toothed belt drive
- ② Hollow shaft motor as direct drive

*Figure 44*  
Application examples,  
rotating screw drive nut

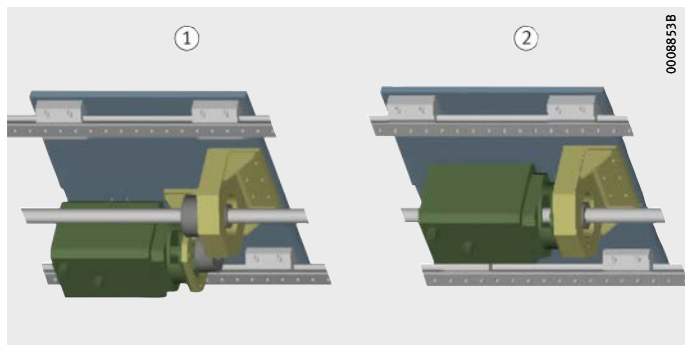

**Advantages  
of a locating/locating  
bearing arrangement**

In addition to axial rigidity, the dynamic characteristics of a screw drive are also important. A locating/locating bearing arrangement can be used to increase the critical whirling speed of the threaded spindle by up to 40% over a comparable locating/non-locating bearing arrangement.

A further aspect is the positional accuracy. If direct linear measuring systems are not used, a locating/locating bearing arrangement can be used to compensate the positional errors arising from spindle heating as long as the threaded spindle is in the tensioned state.

In the design of threaded spindles firmly clamped on both sides, tensioned and with a rotating screw drive nut, increased spindle tensioning is possible without this affecting the bearing rating life. As a result, particularly long threaded spindles with highly dynamic characteristics can be designed. For advice on and the preparation of mounting proposals, please make enquiries with Schaeffler.

# Axial angular contact ball bearings

## Design of a locating/locating bearing arrangement

Where there is a locating bearing arrangement on one side (with or without a non-locating bearing on the opposing side, the threaded spindle may undergo thermal expansion without this changing the load on the bearing position. This does not apply in the case of the locating/locating bearing arrangement.



In order to allow the described advantages of a locating/locating bearing arrangement on both sides, some guidelines on design must be observed. If this is not done, it may lead to a reduced rating life or premature failure of the screw drive bearings.

## Principles of a locating/locating bearing arrangement on both sides

A locating/locating bearing arrangement on both sides of a threaded spindle results in a statically overdefined system. In this case, the threaded spindle undergoes heating in operation and expands in length. This increase in length of the threaded spindle is, however, suppressed by the locating/locating bearing arrangement on both sides, with the result that high compressive forces occur in the spindle. These can lead to buckling of the spindle and overloading of the screw drive bearings.

## Tensioning of the threaded spindle

In order to avoid overloading of the screw drive bearings, threaded spindles with a locating/locating bearing arrangement on both sides are elastically tensioned while they are cold. This is carried out during mounting by means of either a precision locknut and a calculated tightening torque, *Figure 41*, page 42, or a shim with a calculated adjustment gap, *Figure 42*, page 42.

The dimension for tensioning must be calculated for each application and is based on the expected mean operating temperature of the threaded spindle. The threaded spindle is tensioned while cold to at least the extent that no compressive forces will occur in the spindle when warm from operation. For design, either our calculation service or the free-of-charge calculation tool BEARINX-online accessible via an Internet connection can be used.

## Highly dynamic or difficult-to-predict operating conditions

If considerable heating is present or the spindle operating conditions cannot be defined, tempering of the threaded spindle is necessary.

Alternatively, the design principle based on a rotating screw drive nut has proved effective. This is a technically high quality and high performance solution that allows higher tensioning forces to be used, since these do not have an effect on the bearing rating life, *Figure 43*, page 43.

In more economical solutions, the compressive forces occurring in the spindle change the function of the bearing arrangement to a locating/non-locating bearing arrangement. If the losses in terms of axial rigidity and critical whirling speed are accepted, this method allows economical prevention of total failure of the system, *Figure 46* and *Figure 47*, page 46.

## Influence of the design on bearing rating life

Through tensioning of the spindle, the screw drive bearings are subjected to high load on one side while cold. In this case, the triple row axial angular contact ball bearings DKLFA are suitable, since these have particularly high load carrying capacity on one side.

The bearing rating life is directly dependent on the deviation between the assumed design temperature for spindle tensioning and the actual mean operating temperature of the threaded spindle, *Figure 45*.

The following statements can be derived as a result:

- Cold starting of the machine reduces the bearing rating life, since the spindle tensioning forces then apply a high degree of load to the bearing positions.
- If the operating temperature actually present deviates too much from the operating temperature assumed for the design of spindle tensioning, this will reduce the bearing rating life.
- In applications where operating conditions are difficult to predict, unpredictably high heating of the threaded spindle can lead to compressive loading of the spindle with the risk of buckling.



$L_{10h}$  = bearing rating life  
 $\Delta T$  = deviation of actual operating temperature from design temperature

- ① Optimum operating range
- ② Cold, high spindle tensioning forces
- ③ Compressive load in threaded spindle

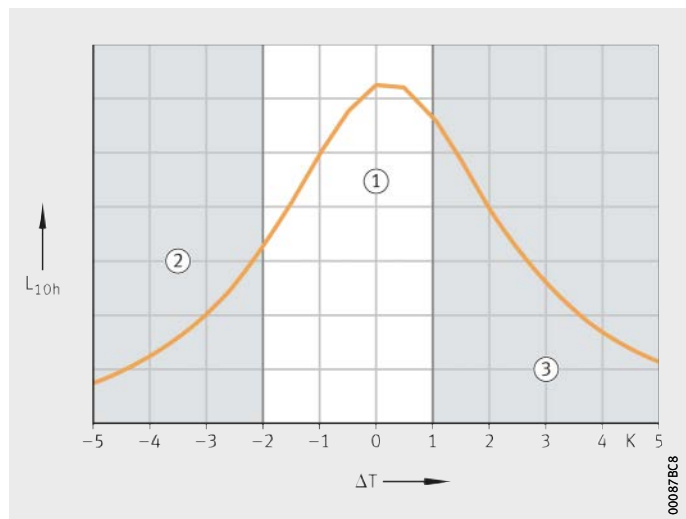

*Figure 45*  
 Calculation of bearing rating life

# Axial angular contact ball bearings

## Economical overload protection in O arrangement

At one of the two bearing positions (generally the one opposing the drive), disc springs are added to the fixing screws and lightly preloaded with the screws, *Figure 46*. The screws are secured against loosening by means of suitable adhesive.

① Disc springs to DIN 2093; the quantity required must be calculated

*Figure 46*  
Overload protection by means of disc springs (design example)

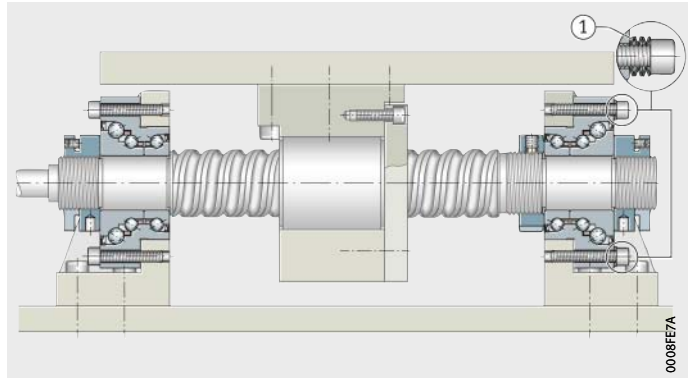

## Economical overload protection in X arrangement

At one of the two bearing positions, the bearing seat on the shaft is designed as a sliding seat, *Figure 47*. If the spindle operating temperature changes within the scope of the design temperature for spindle tensioning, a locating/locating bearing arrangement is present. If higher temperatures occur, the spindle can expand without constraint, as a result of which the bearing arrangement becomes a locating/non-locating bearing arrangement. In order to prevent fretting corrosion at the sliding seat, suitable coatings such as hard chromium must be used.

① Sliding seat of bearing on shaft

*Figure 47*  
Overload protection by means of sliding seat of bearing on shaft (design example)

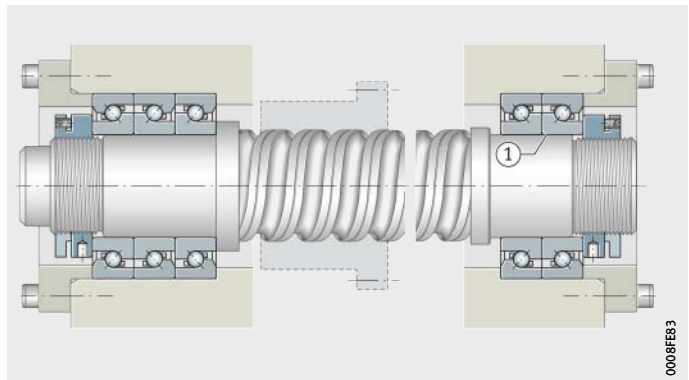



## Design of adjacent construction



The adjacent construction (the shaft and housing) must be designed in accordance with the data in the dimension tables.

The abutment diameters for the shaft and housing shoulders  $d_a$  and  $D_a$  must be in accordance with the dimension tables.

$D_a$  and  $d_a$  are recommended minimum abutment diameters. If these values are not used, the rib diameter  $d_1$  according to the dimension table must be observed.

Pitch and quantity of fixing screws

The data in the dimension tables must be observed:

- For the axial angular contact ball bearings ZKLF for screw mounting, the dimension tables give both the quantity and pitch of the fixing screws for the bearing as well as the quantity and pitch of the threaded fixing holes in the adjacent construction.
- In the case of the sizes of axial angular contact ball bearings ZKLF that are also available in the matched pair design 2AP, the individual bearings can have twice as many fixing holes in comparison with the adjacent construction. In these cases, the bearings are mounted leaving every second fixing hole unused.



For matched pairs of bearings

In matched pairs of axial angular contact ball bearings ZKLN and ZKLF, the depth of the housing bore must be defined such that the outer ring of the outermost bearing is radially supported to at least  $1/4$  of its width.

The extraction slot for damage-free dismantling of the innermost bearing cannot be used, *Figure 48*, page 47. If the bearing is to be dismantled without damage, threaded extraction holes must be present in the screw mounting face of the adjacent construction.

### ZKLF..-2AP

- ① Radial support
- ② Extraction slot not available for use
- ③ Thread optionally available as threaded extraction hole for damage-free bearing dismantling

*Figure 48*  
Design example of adjacent construction for ZKLF..-2AP

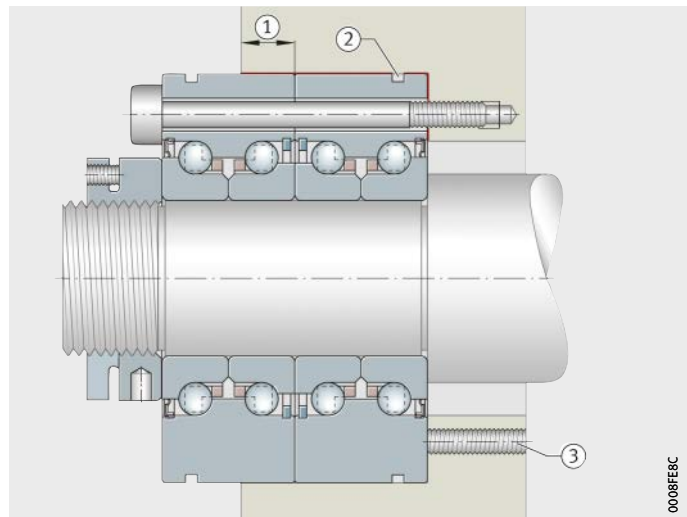

# Axial angular contact ball bearings

## Location of outer ring using ring nut for ZKLN, 7602, 7603, BSB

Axial angular contact ball bearings ZKLN, 7602, 7603 and BSB must be located clearance-free in the housing and on the shaft and must be axially preloaded during mounting. The axial preload force must be distributed evenly over the circumference in order to avoid deformation of the raceways.

Outer rings are axially tensioned to the preload force given in the dimension table by means of a ring nut (not included in the scope of delivery), *Figure 49*. The ring nut must be secured against loosening (for example using Loctite 638).

Ring nuts with an axial runout of max. 5 µm apply the preload force evenly over the bearing rings and should therefore be used in preference to location by means of a cover.

ZKLN, 7602, 7603, BSB

① Ring nut

*Figure 49*

2 bearing set in X arrangement, locknut AM, ring nut

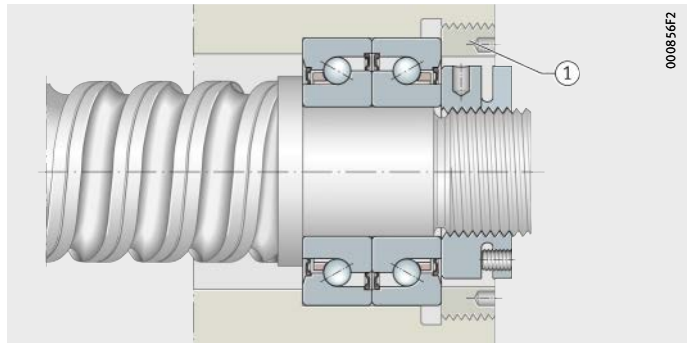

## Location of outer ring using a cover

Clamping of the outer rings using a cover and cap screws leads to deformation of the raceways, *Figure 50*. In order to minimise the deformation and achieve the calculated rating life:

- The cover should be designed with adequate rigidity
- The number of fixing screws should be selected in accordance with the load but at least four should be used
- Tighten the screws in a cross-wise sequence in four stages (finger tight, 40%, 70%, 100% of  $M_A$ ).



Observe the outer axial preload force in the dimension table. If other values are used, this will influence the bearing preload, bearing friction and heat generation in the bearing position.

ZKLN, 7602, 7603, BSB

① Cover

② Locknut

③ Gap before tightening of the cover fixing screws

*Figure 50*

2 bearing set in O arrangement, locknut AM, cover

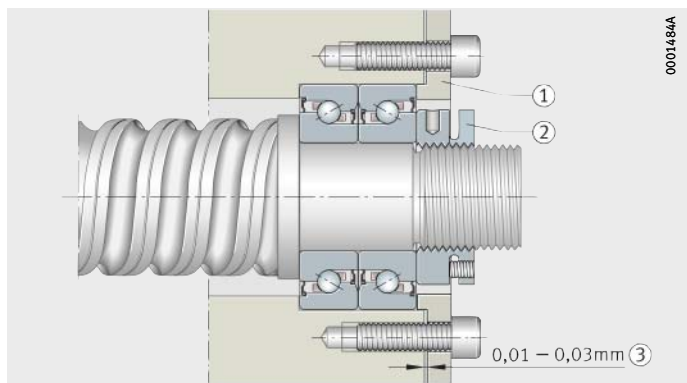

**Radial centring of matched pairs of bearings ZKLf..-2AP screw mounted on a flat surface using a centring ring**

Matched pairs of axial angular contact ball bearings ZKLf..-2AP screw mounted on a flat surface must be radially centred, *Figure 51*.

**Radial centring of bearings**

- ▶ Prepare a centring ring and push it over the joint between the two bearings. The ring must be in contact with the screw mounting face of the adjacent construction.
- ▶ Secure the ring axially using a commercially available retaining ring in the extraction groove of the bearing.

**Dimensions of the ring**

Guidelines on the dimensions of the ring, *Figure 52*:

- The dimensions D and d relate to the outside diameter D of the bearing, see dimension table.
- The width of the ring is the dimension l, see dimension table.

- ① Centring ring
- ② Retaining ring

*Figure 51*  
Radial centring of matched pair of axial angular contact ball bearings ZKLf during mounting on face

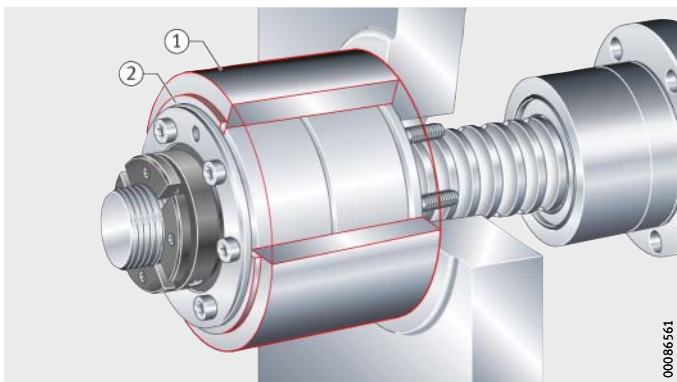

00086561

*Figure 52*  
Dimensions of centring ring

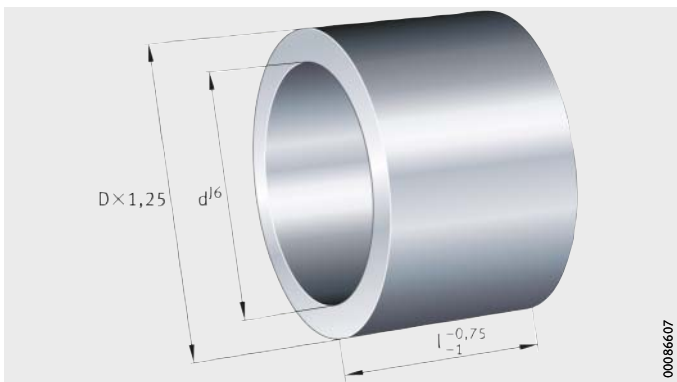

00086607

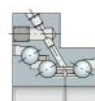

## Axial angular contact ball bearings

### Screw mounting of triple row angular contact ball bearings

Triple row angular contact ball bearings DKLFA are located on the adjacent construction as follows, *Figure 53*:

- in the centring bore
- on the face and thus radially capable of radial alignment using the linear guidance system and screw drive as a datum.

- DKLFA**
- ① Bearing centred in adjacent construction
  - ② Bearing capable of radial alignment

*Figure 53*  
Mounting variants  
of bearing unit DKLFA

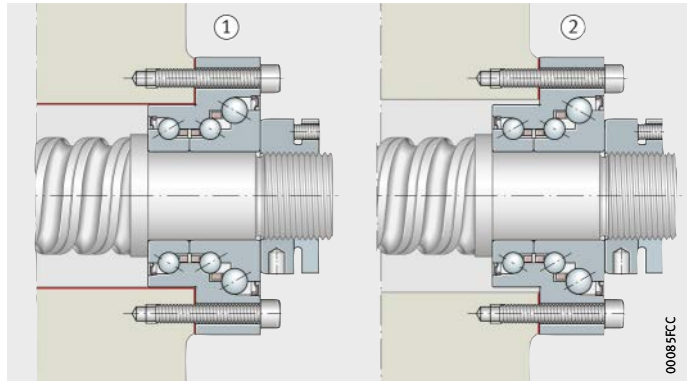

## Speeds

The dimension tables give two different speed parameters:

- the maximum permissible limiting speed  $n_G$
- the thermally safe operating speed  $n_{\vartheta}$  for precision applications.

### Limiting speed $n_G$

The limiting speed  $n_G$  is based on practical experience and test rig runs. It is the speed limit up to which the bearings can be operated as a maximum without kinematic processes in the rolling bearing leading to premature damage to the bearing. In bearings with contact seal lips 2RS, the speed is restricted by the seal material and its maximum permissible sliding velocity at the seal lip.

Under favourable environmental influences, higher limiting speeds can be achieved by using a bearing with minimal gap seals (suffix 2Z) instead of contact seals.



### Thermally safe operating speed $n_{\vartheta}$

The limiting speed  $n_G$  described allows heating of the bearing, which is generally undesirable for precision applications such as in machine tools. The guide value  $n_{\vartheta}$  proven in practice for maximum speeds in machine tool applications is an empirical value at which, for an operating duration of max. 25% and without external operating loads, the bearing temperature is max. 50 °C. In this case, only the bearing preload is present.

If the environmental conditions are known, the equilibrium temperature to be anticipated at the bearing position can be determined by means of a thermal balance calculation.



# Axial angular contact ball bearings

**Friction** In most applications, preloading of bearings by means of the locknut tightening torque gives sufficiently accurate setting values. The reference here is the tightening torque  $M_A$  in accordance with the dimension tables in conjunction with an INA precision locknut.

The bearing frictional torque  $M_{RL}$  given in the dimension tables is a guide value for design of the drive. The actual values are generally lower. The values for bearing frictional torque relate in the case of axial angular contact ball bearings ZKLN, ZKLF, ZKLFA, DKLFA, 7602..-2RS, 7603..-2RS, BSB..-2RS and ZKLR to grease lubrication and are measured at a speed of  $n = 5 \text{ min}^{-1}$  and at room temperature ( $\vartheta = 20 \text{ °C}$ ).

In the case of open axial angular contact ball bearings 7602, 7603 and BSB, the bearing frictional torque  $M_{RL}$  relates to lightly oiled raceways.

For dimensioning of the drive, the starting frictional torque and the frictional torque at high speeds in each case of  $2 \cdot M_{RL}$  to  $3 \cdot M_{RL}$  must be taken into consideration.

**Seal friction** In axial angular contact ball bearings with contact seals (suffix 2RS), the extent of seal friction cannot be disregarded. Sealing influences the limiting speeds and the heating of the bearing.

**Frictional energy** In any analysis of the thermal balance, the various operating speeds  $n_i$  must be taken into consideration with their time durations  $q_i$ .

The frictional energy  $N_R$  of the bearings can be calculated as follows:

$$N_R = \frac{M_{RL} \cdot n}{9,55}$$

$N_R$	W
Frictional energy	
$M_{RL}$	Nm
Bearing frictional torque	
$n$	$\text{min}^{-1}$
Operating speed.	

## Lubrication

Bearings for screw drives can be lubricated with grease or oil. In machine tools, however, the mean bearing temperature should not exceed +50 °C. If this is the case, a lubrication method without heat dissipation such as grease lubrication or oil impulse lubrication can be selected.



For higher bearing temperatures and open bearings, recirculating oil lubrication should be used.

## Grease lubrication

Bearings with a relubrication facility of series ZKLN, ZKLF, ZKLFA and DKLFA are greased with a lithium soap grease GA28 and are preferably run with grease lubrication. In most cases, the initial greasing is sufficient for the operating life of the bearings.

Under certain application conditions, relubrication may be necessary. In this case, Arcanol MULTITOP is suitable. The initial greasing is compatible with greases with a mineral oil base.

For checking by calculation of the grease operating life, relubrication interval and relubrication quantity on the basis of a duty cycle (speed, load, operating duration, environmental conditions), please contact us.



## Relubrication interval

The relubrication intervals cannot be determined precisely in advance. They are essentially dependent on the operating conditions and the environmental influences such as temperature, contamination, dust, water, etc.



Bearings must always be relubricated:

- before and after long stoppage periods
- in conditions of high humidity
- within the defined lubrication intervals as stated in the technical proposal letter.

For the following conditions, please contact us:

- stationary bearings
- vibrations
- very small oscillating movements.



## Relubrication quantity

If axial angular contact ball bearings ZKLN, ZKLF, ZKLFA and DKLFA must be relubricated due to the application conditions, please contact us regarding the relubrication quantities.

## Oil lubrication

Other lubrication methods such as oil impulse lubrication or recirculating oil lubrication are also possible. Oils CLP to DIN 51517-3 and HLP to DIN 51524-2 of ISO VG 32 to ISO VG 100 have proved effective for oil lubrication.

If oil impulse lubrication is intended for axial angular contact ball bearings ZKLN and ZKLF, gap seals are advantageous. They prevent contamination entering the bearing and allow oil to leave the bearing. This prevents overlubrication.

# Axial angular contact ball bearings

## Mounting guidelines

Axial angular contact ball bearings are self-retaining and the individual bearing components are matched to each other. The inner rings must not be removed from the bearing during mounting and dismounting. If individual bearing components are removed from the bearing, please contact Schaeffler before carrying out any reassembly.

The characteristics of the bearings are only valid when used in combination with INA precision locknuts and the associated tightening torques given in the dimension tables.



During the mounting of bearings, mounting forces should be applied only to the bearing ring to be mounted. Mounting forces must never be directed through the rolling elements or sealing rings.

Bearings should only be mounted and dismantled in accordance with the Mounting and Maintenance Manual TPI 100.

## Further information

- TPI 100, Bearings for Screw Drives, Mounting and Maintenance Manual
- Download and ordering: <http://medien.schaeffler.de>.

## Location of inner ring using locknut

Axial angular contact ball bearings must be axially preloaded during mounting by means of a precision locknut.

The performance data given in the dimension tables are only valid if the specified preload forces are observed. The tightening torques for INA precision locknuts required for this purpose are also given in the dimension tables.

The tightening torques for the individual bearing sizes are only valid for the INA precision locknuts listed.

For locating/non-locating bearing arrangements and bearing arrangements for rotating ball screw drive nuts, the tightening torques can be taken directly from the dimension tables.

For locating/locating bearing arrangements, the value in the dimension table can only be used for the locknut ①, *Figure 54*, page 55, and *Figure 55*, page 55. For the other locknuts ② and ③, the tightening torques must be calculated using BEARINX, taking account of the application-specific design criteria.



Calculation can be carried out free of charge using BEARINX-online Easy BallScrew or can be requested. The tightening torques calculated must be observed.



### Preventing settling

In order to counteract settling, the following tightening sequence must be observed:

- ▶ Tighten the precision locknut to twice the tightening torque  $M_A$  and then relieve the load again.
- ▶ Tighten the precision locknut to the stated tightening torque  $M_A$ .
- ▶ Secure the precision locknut against rotation by the torque-controlled tightening of the grub screws.



If other suitable locknuts are used, the manufacturer's guidance on calculation of the necessary tightening torque must be observed. Only use locknuts with a minimum radial runout accuracy of the end face to the thread of 5  $\mu\text{m}$ .

- ①  $M_A$  taken from dimension table
- ②, ③  $M_A$  calculated using BEARINX

*Figure 54*  
Tightening torques of locknuts  
in locating/locating bearing  
arrangement for angular contact  
ball bearing units

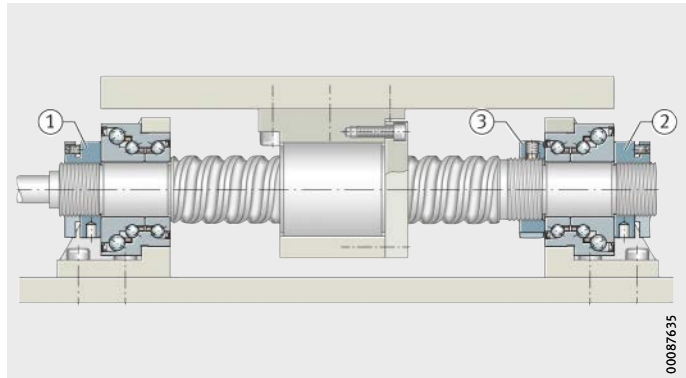

- ①  $M_A$  taken from dimension table
- ②  $M_A$  calculated using BEARINX

*Figure 55*  
Tightening torques of locknuts  
in locating/locating bearing  
arrangement for angular contact  
ball bearing units in X arrangement

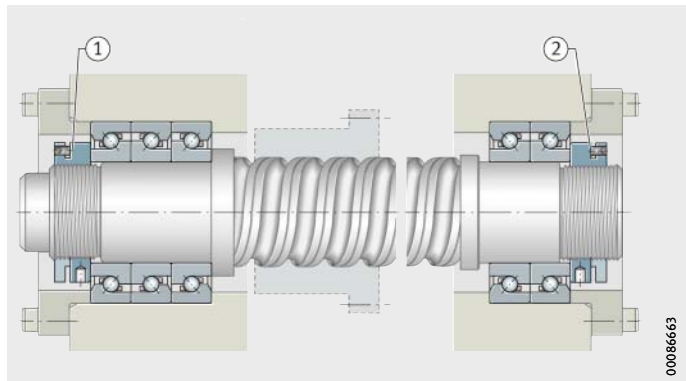

# Axial angular contact ball bearings

## Fixing screws

For location of the outer ring, screws of grade 10.9 should be used. Screws should be fully tightened with torque control in accordance with the manufacturer's instructions and in a crosswise sequence.

If the bearing outer ring is supported by an additional housing cover, it must be ensured that the fixing screws are sufficiently well dimensioned.

## Radial alignment of bearing position

Radial alignment of the bearing position to the threaded spindle with axial angular contact ball bearings ZKLF, ZKLFA, DKLFA and ZKLR, *Figure 56* and *Figure 57*, page 57:

- ▶ Screw mount the bearing directly on the adjacent construction. Tighten the screws only loosely, since the bearing must still be capable of radial displacement.
- ▶ Move the screw drive nut towards the bearing position (the position of the screw drive is the datum via the linear guidance system, the nut serves as a functional element for alignment). The bearing will align itself to the optimum radial position (due to the constraining forces exerted by the datum).
- ▶ Tighten the fixing screws in a crosswise sequence to the specified tightening torque.

- ① Axial angular contact ball bearing ZKLF
- ② Fixing screws
- ③ Screw drive nut

*Figure 56*  
Radial alignment of the bearing position to the threaded spindle with axial angular contact ball bearings suitable for screw mounting

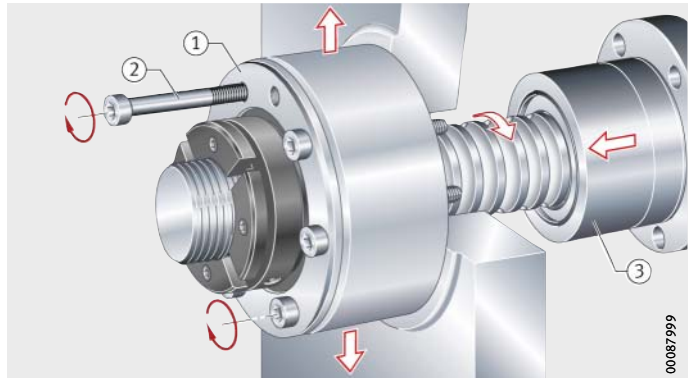

**Mounting of angular contact ball bearing units**

Angular contact ball bearing units ZKLR require no additional preload after mounting, see page 56. They can often therefore be located on the threaded spindle simply by means of clearance-free clamping, *Figure 57*.



The type of axial location depends on the load to be supported. The adjacent construction can be a milled flat face or, if necessary, even an unmachined screw mounting surface without radial centring.

**ZKLR**

- ① Bearing unit with locknut
- ② Threaded spindle
- ③ Tightening of fixing screws finger tight
- ④ Nut of screw drive
- ⑤ Tightening of fixing screws

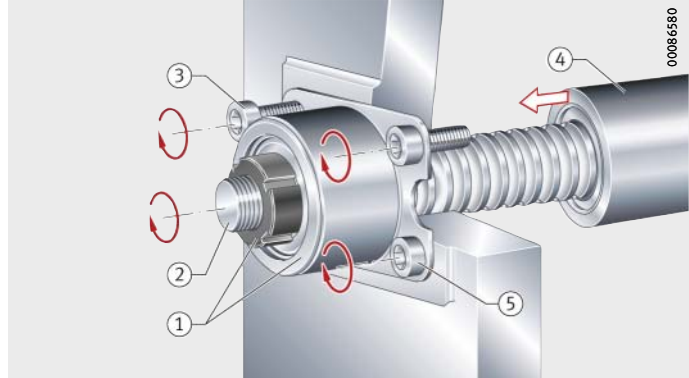

*Figure 57*  
Mounting of bearing unit ZKLR

# Axial angular contact ball bearings

## Calculation example of screw drive bearing ZKLF30100-2Z-XL

Arrangements of screw drive bearings with a locating bearing arrangement on one side and a locating/non-locating bearing arrangement can be calculated, unless the bearing arrangement is subjected to tilting moment load, using either the following equations or with the calculation software BEARINX-online Easy BallScrew.

If a tilting moment load on the bearing arrangement is to be taken into consideration or statically overdefined systems such as arrangements with locating/locating bearings, calculation must be carried out using the calculation program BEARINX. This also applies if, instead of the basic rating life  $L_{10h}$ , the expanded rating life  $L_{nm}$  is to be calculated. In this case, please consult Schaeffler or use the freely available program BEARINX-online Easy BallScrew: <http://bearinx-online-easy-ballscrew.schaeffler.com>.

Given data

The given data for calculation of the rating life are as follows:

- arrangement of screw drive bearings with locating bearing arrangement on one side
- pure axial load.

- ① Locknut
- ② Axial angular contact ball bearing ZKLF30100-2Z-XL
- ③ Nut

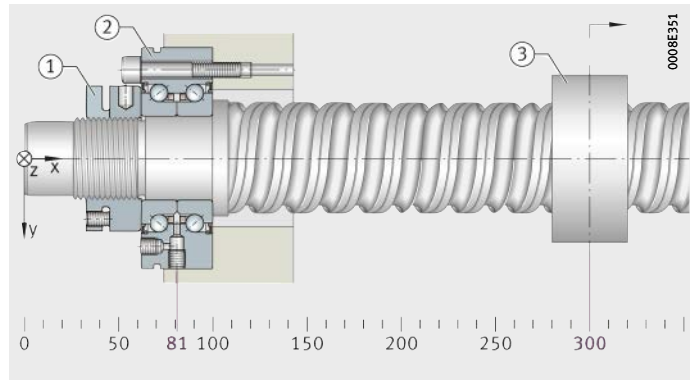

Figure 58  
Specified screw drive bearing  
arrangement

Operating parameters

Operating temperature  $\vartheta = +40\text{ °C}$   
 Nominal viscosity at  $+40\text{ °C}$   $\nu_{40} = 55\text{ mm}^2 \cdot \text{s}^{-1}$   
 Life exponent for ball bearings  $p = 3$   
 Contamination factor  $e_c = 0,5$   
 (normal cleanliness)

Bearing data

Axial angular contact ball bearing = ZKLF30100-2Z-XL  
 Basic dynamic load rating  $C_a = 65\ 000$   
 Basic static load rating  $C_{0a} = 108\ 000$   
 Fatigue limit load  $C_u = 6\ 400\ \text{N}$

Required

- Expanded rating life.

**Permissible limiting load**

The checking of limiting loads is carried out with the aid of the diagrams for determining the resultant bearing load  $F_{a\ res}$ , see page 33.

The limiting load of 11 000 N taken from the diagrams is greater than the maximum operating load occurring  $F_{aB\ max} = 10\ 500\ N$ , which means that all the rows in the load are under preload at maximum load.

**Static load safety factor  $S_0$**

The static load safety factor  $S_0$  of the bearing should be  $\geq 4$  in machine tools. Under pure axial load,  $P_0 = F_{a\ res} \approx 10\ 500\ N$ .

$$S_0 = \frac{C_0}{P_0}$$

$$S_{0a} = \frac{108\ 000\ N}{10\ 500\ N} = 10,3$$

The result of the calculation shows that the static load safety factor is sufficiently high.

**Dynamic forces due to the machining cycle**

Calculation of the rating life  $L_{10h}$  is carried out using the values from the speed and load duty cycle, see table. The resultant bearing load  $F_{a\ res}$  is determined from the diagram, *Figure 26*, page 34.

**Speed and load spectrum for the machining cycle, dynamic values**

Load case i	Time proportion $q_i$ %	Speed $n_i$ $\text{min}^{-1}$	Operating load $F_{aB}$ N	Resultant bearing load N
1 rapid traverse	15	3 000	1 000	5 000
2 acceleration	15	1 500	10 500	10 500
3 rough machining	55	500	6 000	7 100
4 fine machining	15	100	1 000	5 000

**Basic rating life**

The basic rating life in millions of revolutions is the fatigue life reached or exceeded by 90% of a sufficiently large group of apparently identical bearings before the first evidence of material fatigue develops.

**Equivalent bearing load**

The equivalent bearing load for variation in steps is calculated as follows:

$$P = \sqrt[3]{\frac{q_1 \cdot n_1 \cdot P_1^3 + \dots + q_z \cdot n_z \cdot P_z^3}{q_1 \cdot n_1 + \dots + q_z \cdot n_z}}$$

$$P_a = \sqrt[3]{\frac{15 \cdot 3\ 000 \cdot 5\ 000^3 + 15 \cdot 1\ 500 \cdot 10\ 500^3 + \dots}{15 \cdot 3\ 000 + 15 \cdot 1\ 500 + \dots} + \frac{55 \cdot 500 \cdot 7\ 100^3 + 15 \cdot 100 \cdot 5\ 000^3}{55 \cdot 500 + 15 \cdot 100}} = 7\ 560\ N$$



## Axial angular contact ball bearings

### Equivalent speed

The equivalent speed for variation in steps is calculated as follows:

$$n = \frac{q_1 \cdot n_1 + q_2 \cdot n_2 + \dots + q_z \cdot n_z}{100}$$

$$n = \frac{15 \cdot 3\,000 + 15 \cdot 1\,500 + 55 \cdot 500 + 15 \cdot 100}{100} = 965 \text{ min}^{-1}$$

### Rating life in revolutions

$$L_{10} = \left( \frac{C_a}{P_a} \right)^p$$

$$L_{10} = \left( \frac{65\,000}{7\,560} \right)^3 = 636 \cdot 10^6$$

### Rating life in operating hours

$$L_{10h} = \frac{16\,666}{n} \cdot \left( \frac{C_a}{P_a} \right)^p$$

$$L_{10h} = \frac{16\,666}{965 \text{ min}^{-1}} \cdot \left( \frac{65\,000}{7\,560} \right)^3 = 10\,975 \text{ h}$$

## Expanded rating life calculation

Calculation of the basic rating life  $L$  only takes into consideration the influence of load at the rolling contacts. In addition to the load, the lubrication regime and stress increases due to contamination of the lubricant also have a considerable influence on the fatigue life of a rolling bearing.

The method for calculating the expanded rating life was fundamentally changed in 2007 with the revision of ISO 281.

The term “expanded rating life” was included for the first time in ISO 281:2010 and replaced the “adjusted rating life”.

## Expanded rating life

$$L_{nm} = a_1 \cdot a_{ISO} \cdot L_{10}$$

## Life adjustment factor $a_{ISO}$

The life adjustment factor  $a_{ISO}$  takes into consideration the lubrication regime, the contamination of the lubrication and the fatigue limit of the raceway material, *Figure 59*.

$$a_{ISO} = f \left[ \frac{e_C \cdot C_U}{P}, \kappa \right]$$

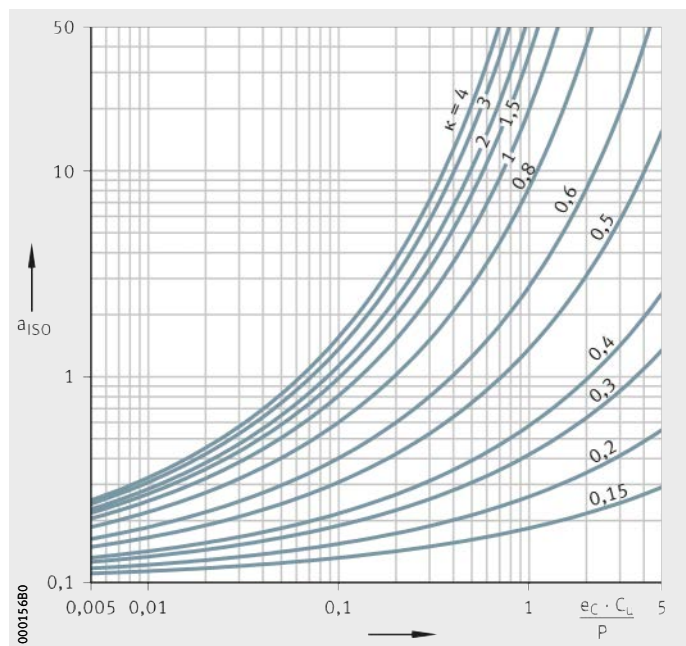

*Figure 59*  
Life adjustment factor  $a_{ISO}$   
for axial ball bearings



# Axial angular contact ball bearings

Calculation of the life adjustment factor  $a_{ISO}$  for load case 1

Based on the contamination factor  $e_C = 0,5$  for normal cleanliness in accordance with ISO 281, the ratio  $(e_C \cdot C_{u1})/P_1$  is determined first.

Based on the nominal viscosity  $\nu_{40} = 55 \text{ mm}^2 \cdot \text{s}^{-1}$ , the operating temperature  $\vartheta = 40 \text{ }^\circ\text{C}$  and the mean bearing diameter  $d_M = d_1$ , the operating viscosity  $\nu$  and the reference viscosity  $\nu_1$  are read from the diagrams, *Figure 60* and *Figure 61*, page 63.



If values  $\kappa > 4$  are determined, calculation should be continued in accordance with ISO 281 using a viscosity ratio  $\kappa = 4$ . If  $\kappa < 0,1$ , the calculation is not valid. In this case, please consult Schaeffler.

**Ratio  $(e_C \cdot C_u)/P_1$**

In conjunction with the fatigue limit load  $C_u$  and the equivalent load in load case 1, this gives:

$$\frac{e_C \cdot C_u}{P_1} = \frac{0,5 \cdot 6\,400 \text{ N}}{5\,000 \text{ N}} = 0,64$$

**Viscosity ratio  $\kappa$**

The viscosity ratio  $\kappa = \nu/\nu_1$  is calculated as follows:

$$\kappa = \frac{55 \text{ mm}^2 \cdot \text{s}^{-1}}{12 \text{ mm}^2 \cdot \text{s}^{-1}} = 4,6$$

$\nu/\vartheta$  diagram for mineral oils

$\nu$  = operating viscosity  
 $\vartheta$  = operating temperature  
 $\nu_{40}$  = viscosity at +40 °C

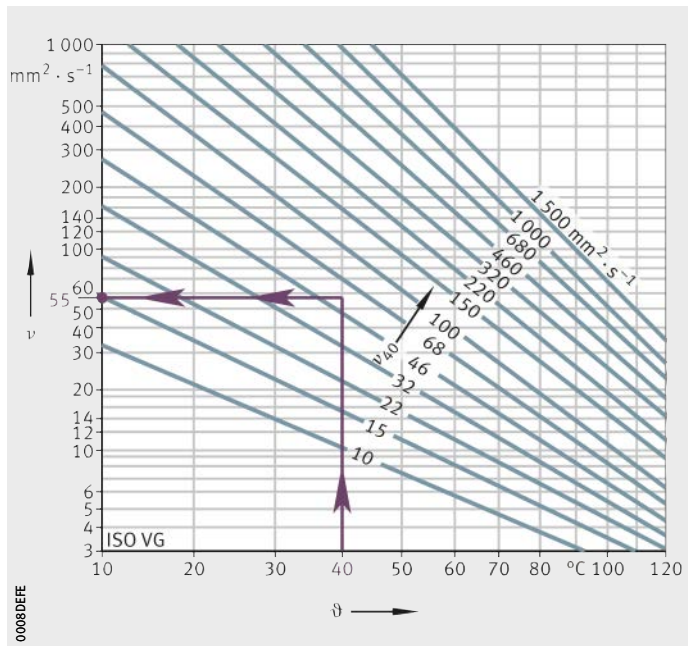

*Figure 60*

Calculation of operating viscosity  $\nu$  at operating temperature  $\vartheta$



For ZKLF30100:  
 $d_M = d_1 = 51 \text{ mm}$

$\nu_1$  = reference viscosity  
 $d_M$  = mean bearing diameter  
 $n$  = speed

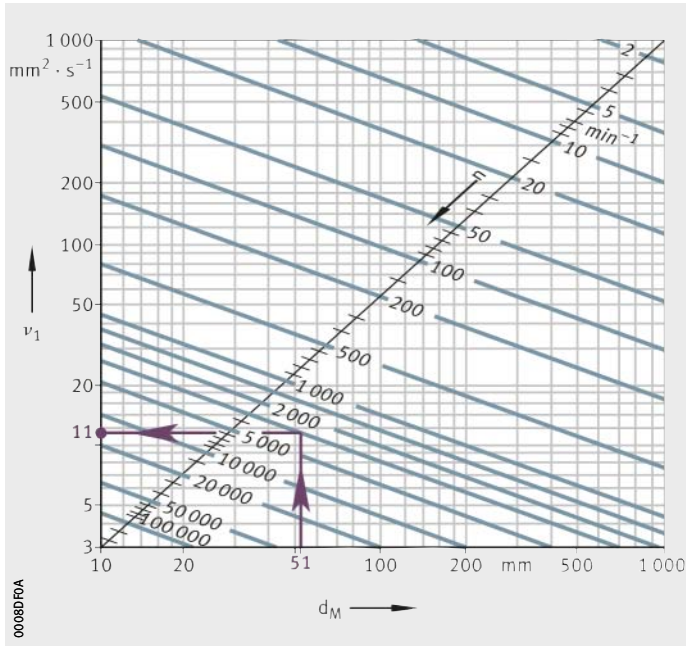

Figure 61  
 Calculation of reference viscosity  $\nu_1$

**Life adjustment factors  $a_{150}$   
 for current operating condition**

Calculation of	Load case			
	1	2	3	4
$(e_C \cdot C_U) / P$	0,64	0,30	0,45	0,64
Operating viscosity $\nu$	55	55	55	55
Reference viscosity $\nu_1$	12	16	32	130
Viscosity ratio $\kappa = \nu / \nu_1$	(5) 4	3,4	1,7	0,4
Life adjustment factor $a_{150}$	$a_1$ 35	$a_2$ 6,5	$a_3$ 8,5	$a_4$ 0,5

## Axial angular contact ball bearings

### Calculation of expanded rating life

Calculation of the expanded rating life incorporates not only the life adjustment factor  $a_{ISO}$  but also a life adjustment factor for the reliability  $a_1$ . A reliability of 90% corresponds here to an achievable rating life with a commonly used, high quality material and under normal operating conditions that have proved sufficient over many years. In accordance with ISO 281, the life adjustment factor in this case is  $a_1 = 1$ .

### Equivalent bearing load

The equivalent bearing load for a variation in steps is calculated, taking account of the life adjustment factors, as follows:

$$P = \sqrt[p]{\frac{\frac{1}{a_i} \cdot q_i \cdot n_i \cdot F_i^p + \dots + \frac{1}{a_z} \cdot q_z \cdot n_z \cdot F_z^p}{q_i \cdot n_i + \dots + q_z \cdot n_z}}$$

$$P_a = \sqrt[3]{\frac{\frac{1}{35} \cdot 15 \cdot 3\,000 \cdot 5\,000^3 + \frac{1}{6,5} \cdot 15 \cdot 1\,500 \cdot 10\,500^3}{15 \cdot 3\,000 + 15 \cdot 1\,500} + \dots + \frac{1}{8,5} \cdot 55 \cdot 500 \cdot 7\,100^3 + \frac{1}{0,5} \cdot 15 \cdot 100 \cdot 5\,000^3}{55 \cdot 500 + 15 \cdot 100}}$$

$$= 3\,895 \text{ N}$$

### Expanded rating life

The rating life is calculated as follows, see page 60 and page 61:

$$L_{10m} = \frac{16\,666}{965 \text{ min}^{-1}} \cdot \left( \frac{65\,000 \text{ N}}{3\,895 \text{ N}} \right)^3 = 80\,264 \text{ h}$$

**Comparison with BEARINX-online Easy BallScrew**

The catalogue calculation method in accordance with ISO 281 does not reflect the influence of bearing clearance, tilting or other influencing factors. As a result, deviations may arise compared to the more detailed calculation method in accordance with ISO/TS 16281, which is used in BEARINX-online.

In this example, calculation using BEARINX-online gives a minimum rating life  $L_{h\ min} = 64\ 729$  h.

Calculation using BEARINX is not carried out with a static  $e_c$  value; the contamination factor is calculated for each load case in accordance with ISO 281. This gives a more accurate result in rating life calculation.

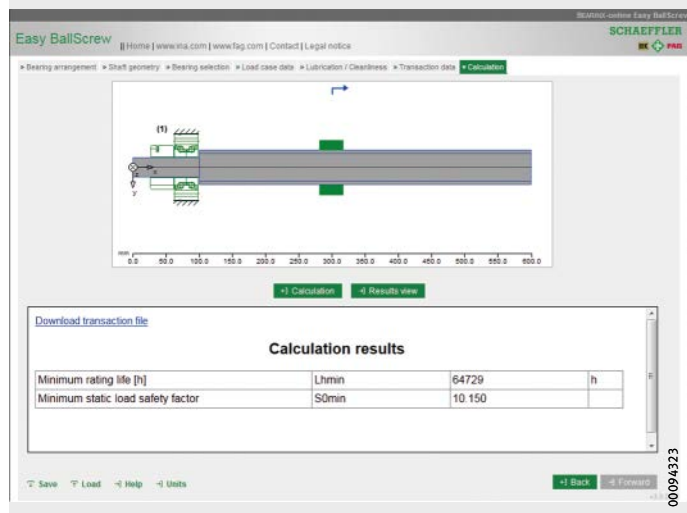
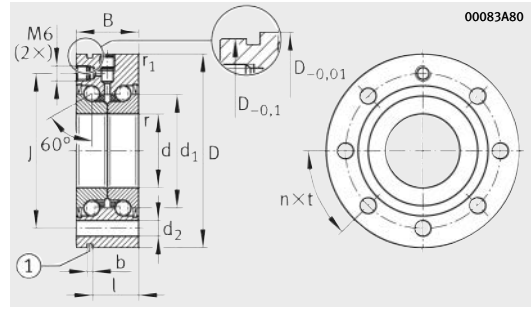

*Figure 62*  
Calculation result using BEARINX-online



# Axial angular contact ball bearings

For screw mounting



ZKLF..-2RS, ZKLF..-2Z (d ≤ 50 mm)

**Dimension table** - Dimensions in mm

Designation	X-life	Mass m ≈ kg	Dimensions					
			d -0,005	D -0,01	B -0,25	d <sub>1</sub>	r min.	r <sub>1</sub> min.
ZKLF1255-2RS	XL	0,37	12	55	25	25	0,3	0,6
ZKLF1255-2Z	XL	0,37	12	55	25	25	0,3	0,6
ZKLF1560-2RS	XL	0,43	15	60	25	28	0,3	0,6
ZKLF1560-2Z	XL	0,43	15	60	25	28	0,3	0,6
ZKLF1762-2RS	XL	0,45	17	62	25	30	0,3	0,6
ZKLF1762-2Z	XL	0,45	17	62	25	30	0,3	0,6
ZKLF2068-2RS	XL	0,61	20	68	28	34,5	0,3	0,6
ZKLF2068-2Z	XL	0,61	20	68	28	34,5	0,3	0,6

**Performance data**

Designation	X-life	Basic load ratings axial		Fatigue limit load C <sub>u</sub> N	Limiting speeds		Bearing frictional torque M <sub>RL</sub> Nm
		dyn. C <sub>a</sub> N	stat. C <sub>0a</sub> N		n <sub>G</sub> grease min <sup>-1</sup>	n <sub>∅</sub> min <sup>-1</sup>	
ZKLF1255-2RS	XL	18 600	24 700	1 460	9 200	3 800	0,16
ZKLF1255-2Z	XL	18 600	24 700	1 460	12 000	7 600	0,08
ZKLF1560-2RS	XL	19 600	28 000	1 650	8 200	3 500	0,2
ZKLF1560-2Z	XL	19 600	28 000	1 650	10 800	7 000	0,1
ZKLF1762-2RS	XL	20 700	31 000	1 840	7 600	3 300	0,24
ZKLF1762-2Z	XL	20 700	31 000	1 840	10 100	6 600	0,12
ZKLF2068-2RS	XL	28 500	47 000	2 750	6 600	3 000	0,3
ZKLF2068-2Z	XL	28 500	47 000	2 750	8 700	5 400	0,15

① Extraction slot; ② Adjacent construction, bearing screw mounted on flat surface; ③ Adjacent construction, bearing screw mounted in bore; ④ Only valid in assembled condition

- 1) The screws are not included in the scope of delivery. Tightening torque in accordance with manufacturer's data. Number of holes in adjacent construction corresponds to t<sub>a</sub>.
- 2) Based on rotating inner ring.
- 3) The recommended INA precision locknuts are not included in the scope of delivery and must be ordered separately.
- 4) The required axial locknut force must be observed when using other locknuts.
- 5) Only valid in conjunction with INA precision locknuts. Note the guidelines on locating/locating bearing arrangements, see page 54.

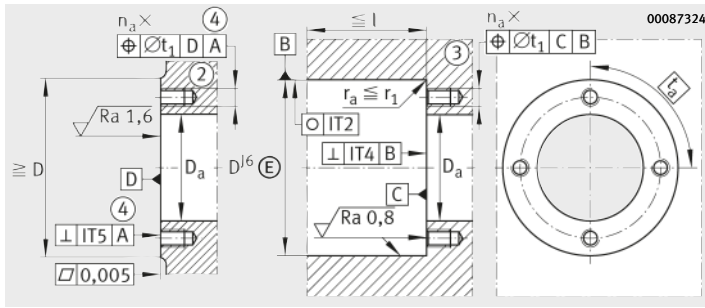

Housing design

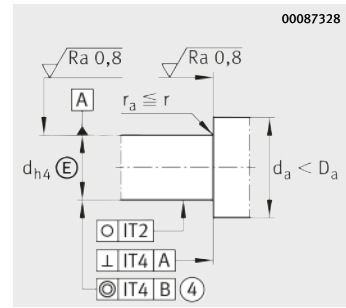

Shaft design  
(threaded spindle)



				Pitch n×t	Mounting dimensions			Fixing screws <sup>1)</sup> DIN EN ISO 4762 10.9	
J	d <sub>2</sub>	b	l		D <sub>a</sub> max.	d <sub>a</sub> min.	t <sub>1</sub>	Size	n <sub>a</sub> ×t <sub>a</sub>
42	6,8	3	17	3×120°	33	16	0,1	M6	3×120°
42	6,8	3	17	3×120°	33	16	0,1	M6	3×120°
46	6,8	3	17	3×120°	35	20	0,1	M6	3×120°
46	6,8	3	17	3×120°	35	20	0,1	M6	3×120°
48	6,8	3	17	6×60°	37	23	0,1	M6	3×120°
48	6,8	3	17	6×60°	37	23	0,1	M6	3×120°
53	6,8	3	19	8×45°	43	25	0,1	M6	4×90°
53	6,8	3	19	8×45°	43	25	0,1	M6	4×90°

Rigidity axial c <sub>aL</sub> N/μm	Tilting rigidity c <sub>kL</sub>	Mass moment of inertia <sup>2)</sup> M <sub>m</sub>	Axial runout <sup>2)</sup> μm	Recommended INA precision locknut <sup>3)</sup>			Required locknut force <sup>4)</sup> axial N
				For radial locking	For axial locking	Tightening torque <sup>5)</sup> M <sub>A</sub> Nm	
375	50	0,068	2	<b>ZM12</b>	–	8	5 307
375	50	0,068	2	<b>ZM12</b>	–	8	5 307
400	65	0,102	2	<b>ZM15</b>	<b>AM15</b>	10	5 484
400	65	0,102	2	<b>ZM15</b>	<b>AM15</b>	10	5 484
450	80	0,132	2	<b>ZM17</b>	<b>AM17</b>	15	7 514
450	80	0,132	2	<b>ZM17</b>	<b>AM17</b>	15	7 514
650	140	0,273	2	<b>ZM20</b>	<b>AM20</b>	18	8 258
650	140	0,273	2	<b>ZM20</b>	<b>AM20</b>	18	8 258

# Axial angular contact ball bearings

For screw mounting

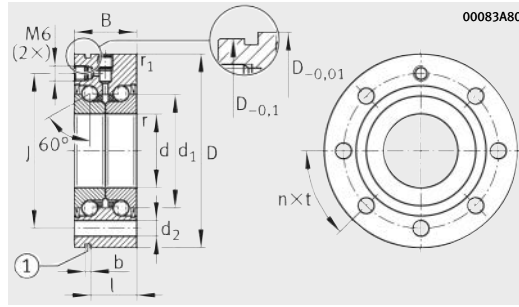

ZKLF..-2RS, ZKLF..-2Z (d ≤ 50 mm)

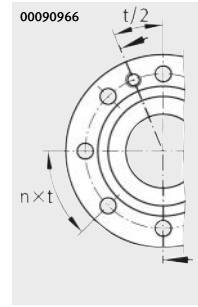

ZKLF30100

**Dimension table** (continued) · Dimensions in mm

Designation	X-life	Mass m ≈ kg	Dimensions					
			d -0,005	D -0,01	B -0,25	d <sub>1</sub>	r min.	r <sub>1</sub> min.
ZKLF2575-2RS	XL	0,72	25	75	28	40,5	0,3	0,6
ZKLF2575-2Z	XL	0,72	25	75	28	40,5	0,3	0,6
ZKLF3080-2RS	XL	0,78	30	80	28	45,5	0,3	0,6
ZKLF3080-2Z	XL	0,78	30	80	28	45,5	0,3	0,6
ZKLF30100-2RS <sup>2)</sup>	XL	1,63	30	100	38	51	0,3	0,6
ZKLF30100-2Z <sup>2)</sup>	XL	1,63	30	100	38	51	0,3	0,6
ZKLF3590-2RS	XL	1,13	35	90	34	52	0,3	0,6
ZKLF3590-2Z	XL	1,13	35	90	34	52	0,3	0,6

**Performance data**

Designation	X-life	Basic load ratings axial		Fatigue limit load C <sub>u</sub> N	Limiting speeds		Bearing frictional torque M <sub>RL</sub> Nm
		dyn. C <sub>a</sub> N	stat. C <sub>0a</sub> N		n <sub>G</sub> grease min <sup>-1</sup>	n <sub>θ</sub> min <sup>-1</sup>	
ZKLF2575-2RS	XL	30 500	55 000	3 250	5 700	2 600	0,4
ZKLF2575-2Z	XL	30 500	55 000	3 250	7 500	4 700	0,2
ZKLF3080-2RS	XL	32 000	64 000	3 750	5 000	2 200	0,5
ZKLF3080-2Z	XL	32 000	64 000	3 750	6 700	4 300	0,25
ZKLF30100-2RS <sup>2)</sup>	XL	65 000	108 000	6 400	4 500	2 100	0,8
ZKLF30100-2Z <sup>2)</sup>	XL	65 000	108 000	6 400	5 600	4 000	0,4
ZKLF3590-2RS	XL	45 000	89 000	5 200	4 400	2 000	0,6
ZKLF3590-2Z	XL	45 000	89 000	5 200	5 800	3 800	0,3

① Extraction slot; ② Adjacent construction, bearing screw mounted on flat surface; ③ Adjacent construction, bearing screw mounted in bore; ④ Only valid in assembled condition

1) The screws are not included in the scope of delivery. Tightening torque in accordance with manufacturer's data. Number of holes in adjacent construction corresponds to t<sub>a</sub>.

2) Heavy series.

3) Based on rotating inner ring.

4) The recommended INA precision locknuts are not included in the scope of delivery and must be ordered separately.

5) The required axial locknut force must be observed when using other locknuts.

6) Only valid in conjunction with INA precision locknuts. Note the guidelines on locating/locating bearing arrangements, see page 54.

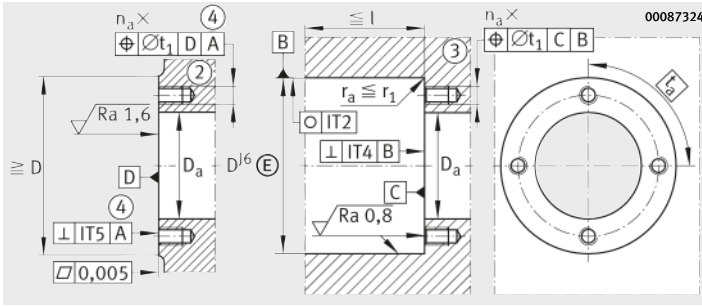

Housing design

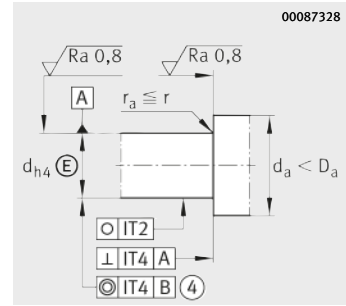

Shaft design  
(threaded spindle)



				Pitch $n \times t$	Mounting dimensions			Fixing screws <sup>1)</sup> DIN EN ISO 4762 10.9	
J	$d_2$	b	l		$D_a$ max.	$d_a$ min.	$t_1$	Size	$n_a \times t_a$
58	6,8	3	19	$8 \times 45^\circ$	48	32	0,1	M6	$4 \times 90^\circ$
58	6,8	3	19	$8 \times 45^\circ$	48	32	0,1	M6	$4 \times 90^\circ$
63	6,8	3	19	$12 \times 30^\circ$	53	40	0,1	M6	$6 \times 60^\circ$
63	6,8	3	19	$12 \times 30^\circ$	53	40	0,1	M6	$6 \times 60^\circ$
80	8,8	3	30	$8 \times 45^\circ$	64	47	0,2	M8	$8 \times 45^\circ$
80	8,8	3	30	$8 \times 45^\circ$	64	47	0,2	M8	$8 \times 45^\circ$
75	8,8	3	25	$8 \times 45^\circ$	62	45	0,2	M8	$4 \times 90^\circ$
75	8,8	3	25	$8 \times 45^\circ$	62	45	0,2	M8	$4 \times 90^\circ$

Rigidity axial	Tilting rigidity	Mass moment of inertia <sup>3)</sup>	Axial runout <sup>3)</sup>	Recommended INA precision locknut <sup>4)</sup>			Required locknut force <sup>5)</sup>
				For radial locking	For axial locking	Tightening torque <sup>6)</sup>	
$c_{aL}$	$c_{kL}$	$M_m$	$\mu\text{m}$			$M_A$	axial
$\text{N}/\mu\text{m}$						Nm	N
750	200	0,486	2	<b>ZM25</b>	<b>AM25</b>	25	9 123
750	200	0,486	2	<b>ZM25</b>	<b>AM25</b>	25	9 123
850	300	0,73	2,5	<b>ZM30</b>	<b>AM30</b>	32	9 947
850	300	0,73	2,5	<b>ZM30</b>	<b>AM30</b>	32	9 947
950	400	1,91	2,5	<b>ZMA30/52</b>	<b>AM30</b>	65	19 509
950	400	1,91	2,5	<b>ZMA30/52</b>	<b>AM30</b>	65	19 509
900	400	1,51	2,5	<b>ZM35</b>	<b>AM35/58</b>	40	10 770
900	400	1,51	2,5	<b>ZM35</b>	<b>AM35/58</b>	40	10 770

# Axial angular contact ball bearings

For screw mounting

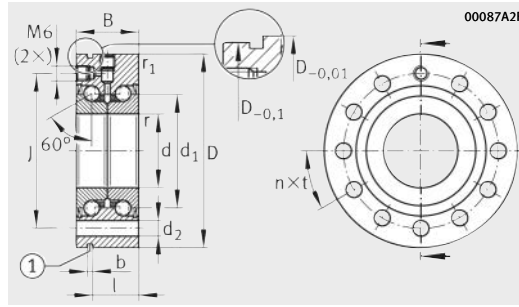

ZKLF..-2RS, ZKLF..-2Z (d ≤ 50 mm)

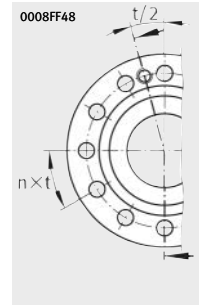

ZKLF40115  
ZKLF50140

**Dimension table** (continued) · Dimensions in mm

Designation	X-life	Mass m ≈ kg	Dimensions					
			d -0,005	D -0,01	B -0,25	d <sub>1</sub>	r min.	r <sub>1</sub> min.
ZKLF40100-2RS	XL	1,46	40	100	34	58	0,3	0,6
ZKLF40100-2Z	XL	1,46	40	100	34	58	0,3	0,6
ZKLF40115-2RS <sup>2)</sup>	XL	2,2	40	115	46	65	0,6	0,6
ZKLF40115-2Z <sup>2)</sup>	XL	2,2	40	115	46	65	0,6	0,6
ZKLF50115-2RS	XL	1,86	50	115	34	72	0,3	0,6
ZKLF50115-2Z	XL	1,86	50	115	34	72	0,3	0,6
ZKLF50140-2RS <sup>2)</sup>	XL	4,7	50	140	54	80	0,6	0,6
ZKLF50140-2Z <sup>2)</sup>	XL	4,7	50	140	54	80	0,6	0,6

**Performance data**

Designation	X-life	Basic load ratings axial		Fatigue limit load C <sub>u</sub> N	Limiting speeds		Bearing frictional torque M <sub>RL</sub> Nm
		dyn. C <sub>a</sub> N	stat. C <sub>0a</sub> N		n <sub>G</sub> grease min <sup>-1</sup>	n <sub>0</sub> min <sup>-1</sup>	
ZKLF40100-2RS	XL	47 500	101 000	6 000	4 000	1 800	0,7
ZKLF40100-2Z	XL	47 500	101 000	6 000	5 200	3 300	0,35
ZKLF40115-2RS <sup>2)</sup>	XL	79 000	149 000	8 800	3 500	1 600	1,3
ZKLF40115-2Z <sup>2)</sup>	XL	79 000	149 000	8 800	4 400	3 100	0,65
ZKLF50115-2RS	XL	51 000	126 000	7 400	3 200	1 500	0,9
ZKLF50115-2Z	XL	51 000	126 000	7 400	4 200	3 000	0,45
ZKLF50140-2RS <sup>2)</sup>	XL	125 000	250 000	14 800	2 900	1 200	2,6
ZKLF50140-2Z <sup>2)</sup>	XL	125 000	250 000	14 800	3 500	2 500	1,3

① Extraction slot; ② Adjacent construction, bearing screw mounted on flat surface; ③ Adjacent construction, bearing screw mounted in bore; ④ Only valid in assembled condition

1) The screws are not included in the scope of delivery. Tightening torque in accordance with manufacturer's data. Number of holes in adjacent construction corresponds to t<sub>a</sub>.

2) Heavy series.

3) Based on rotating inner ring.

4) The recommended INA precision locknuts are not included in the scope of delivery and must be ordered separately.

5) The required axial locknut force must be observed when using other locknuts.

6) Only valid in conjunction with INA precision locknuts. Note the guidelines on locating/locating bearing arrangements, see page 54.



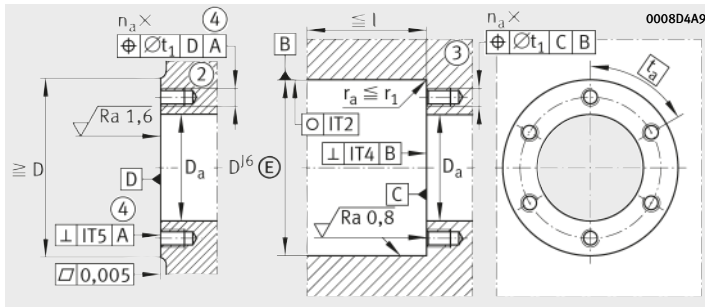

Housing design

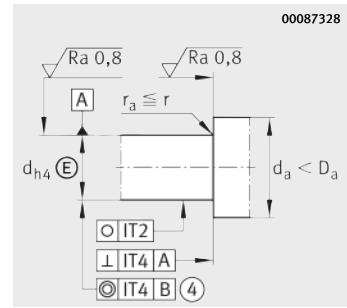

Shaft design  
(threaded spindle)



J	d <sub>2</sub>	b	l	Pitch n×t	Mounting dimensions			Fixing screws <sup>1)</sup> DIN EN ISO 4762 10.9	
					D <sub>a</sub> max.	d <sub>a</sub> min.	t <sub>1</sub>	Size	n <sub>a</sub> ×t <sub>a</sub>
80	8,8	3	25	8×45°	67	50	0,2	M8	4×90°
80	8,8	3	25	8×45°	67	50	0,2	M8	4×90°
94	8,8	3	36	12×30°	80	56	0,2	M8	12×30°
94	8,8	3	36	12×30°	80	56	0,2	M8	12×30°
94	8,8	3	25	12×30°	82	63	0,2	M8	6×60°
94	8,8	3	25	12×30°	82	63	0,2	M8	6×60°
113	11	3	45	12×30°	98	63	0,2	M10	12×30°
113	11	3	45	12×30°	98	63	0,2	M10	12×30°

Rigidity axial	Tilting rigidity	Mass moment of inertia <sup>3)</sup>	Axial runout <sup>3)</sup>	Recommended INA precision locknut <sup>4)</sup>			Required locknut force <sup>5)</sup> axial
				For radial locking	For axial locking	Tightening torque <sup>6)</sup> M <sub>A</sub>	
c <sub>aL</sub>	c <sub>kL</sub>	M <sub>m</sub>	μm			Nm	N
1000	550	2,26	2,5	<b>ZM40</b>	<b>AM40</b>	55	13 412
1000	550	2,26	2,5	<b>ZM40</b>	<b>AM40</b>	55	13 412
1200	750	5,5	2,5	<b>ZMA40/62</b>	<b>AM40</b>	110	25 185
1200	750	5,5	2,5	<b>ZMA40/62</b>	<b>AM40</b>	110	25 815
1250	1000	5,24	2,5	<b>ZM50</b>	<b>AM50</b>	85	16 280
1250	1000	5,24	2,5	<b>ZM50</b>	<b>AM50</b>	85	16 280
1400	1500	15,2	2,5	<b>ZMA50/75</b>	<b>AM50</b>	150	28 451
1400	1500	15,2	2,5	<b>ZMA50/75</b>	<b>AM50</b>	150	28 451

# Axial angular contact ball bearings

For screw mounting

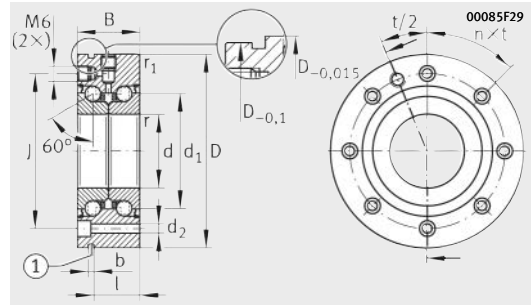

ZKLF..-2Z (60 mm ≤ d ≤ 100 mm)

**Dimension table** (continued) · Dimensions in mm

Designation	X-life	Mass m ≈ kg	Dimensions					
			d	D	B	d <sub>1</sub>	r min.	r <sub>1</sub> min.
ZKLF60145-2Z	XL	4,3	60	145	45	85	0,6	0,6
ZKLF70155-2Z	XL	4,9	70	155	45	95	0,6	0,6
ZKLF80165-2Z	XL	5,3	80	165	45	105	0,6	0,6
ZKLF90190-2Z	XL	8,7	90	190	55	120	0,6	0,6
ZKLF100200-2Z	XL	9,3	100	200	55	132	0,6	0,6
ZKLF100200-2Z	-	17,6	100	230	85	146	0,6	0,6

**Performance data**

Designation	X-life	Basic load ratings axial		Fatigue limit load C <sub>u</sub> N	Limiting speeds		Bearing frictional torque M <sub>RL</sub> Nm
		dyn. C <sub>a</sub> N	stat. C <sub>0a</sub> N		n <sub>G grease</sub> min <sup>-1</sup>	n <sub>ø</sub> min <sup>-1</sup>	
ZKLF60145-2Z	XL	93 000	214 000	12 600	4 000	3 000	1
ZKLF70155-2Z	XL	97 000	241 000	14 200	3 800	2 800	1,2
ZKLF80165-2Z	XL	100 000	265 000	15 400	3 600	2 700	1,4
ZKLF90190-2Z	XL	149 000	395 000	21 300	3 500	2 300	2,3
ZKLF100200-2Z	XL	154 000	435 000	22 400	3 300	2 150	2,6
ZKLF100200-2Z	-	295 000	790 000	29 000	2 900	2 000	3

① Extraction slot; ② Adjacent construction, bearing screw mounted on flat surface; ③ Adjacent construction, bearing screw mounted in bore; ④ Only valid in assembled condition

- 1) The screws are not included in the scope of delivery. Tightening torque in accordance with manufacturer's data. Number of holes in adjacent construction corresponds to t<sub>a</sub>.
- 2) Based on rotating inner ring.
- 3) The recommended INA precision locknuts are not included in the scope of delivery and must be ordered separately.
- 4) The required axial locknut force must be observed when using other locknuts.
- 5) Only valid in conjunction with INA precision locknuts. Note the guidelines on locating/locating bearing arrangements, see page 54.

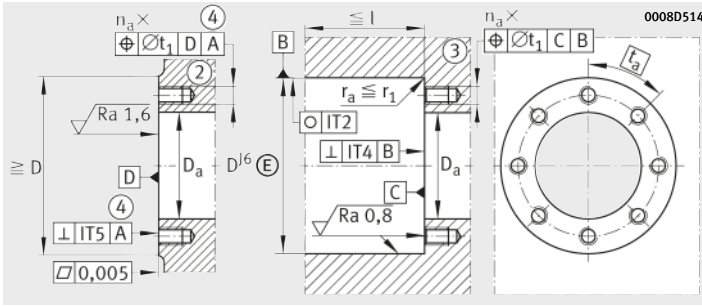

Housing design

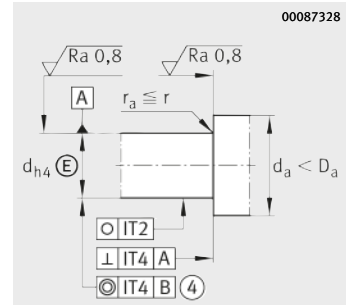

Shaft design  
(threaded spindle)



				Pitch n × t	Mounting dimensions			Fixing screws <sup>1)</sup> DIN EN ISO 4762 10.9	
J	d <sub>2</sub>	b	l		D <sub>a</sub> max.	d <sub>a</sub> min.	t <sub>1</sub>	Size	n <sub>a</sub> × t <sub>a</sub>
120	8,8	3	35	8 × 45°	100	82	0,2	M8	8 × 45°
130	8,8	3	35	8 × 45°	110	92	0,2	M8	8 × 45°
140	8,8	3	35	8 × 45°	120	102	0,2	M8	8 × 45°
165	11	3	45	8 × 45°	138	116	0,2	M10	8 × 45°
175	11	3	45	8 × 45°	150	128	0,2	M10	8 × 45°
200	14	3	73	12 × 30°	175	130	0,4	M12	12 × 30°

Rigidity axial c <sub>aL</sub> N/μm	Tilting rigidity c <sub>kL</sub>	Mass moment of inertia <sup>2)</sup> M <sub>m</sub>	Axial runout <sup>2)</sup> μm	Recommended INA precision locknut <sup>3)</sup>			Required locknut force <sup>4)</sup> axial N
				For radial locking	For axial locking	Tightening torque <sup>5)</sup> M <sub>A</sub> Nm	
1300	1650	13,7	3	<b>ZMA60/98</b>	<b>AM60</b>	100	16 700
1450	2250	19,8	3	<b>ZMA70/110</b>	<b>AM70</b>	130	19 031
1600	3000	27,6	3	<b>ZMA80/120</b>	<b>AM80</b>	160	20 604
1700	4400	59,9	3	<b>ZMA90/130</b>	<b>AM90</b>	200	22 731
1900	5800	85,3	3	<b>ZMA100/140</b>	<b>AM100</b>	250	25 624
2450	8200	185	3	–	<b>AM100</b>	500	52 000

# Axial angular contact ball bearings

For screw mounting  
Less stringent tolerances

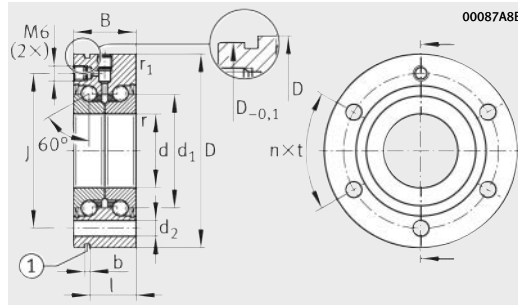

ZKLF..-2RS-PE

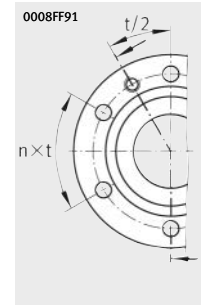

ZKLF12, ZKLF15

**Dimension table** - Dimensions in mm

Designation	Mass m ≈ kg	Dimensions					
		d -0,01	D	B -0,25	d <sub>1</sub>	r min.	r <sub>1</sub> min.
ZKLF1255-2RS-PE	0,37	12	55 <sub>-0,013</sub>	25	25	0,3	0,6
ZKLF1560-2RS-PE	0,43	15	60 <sub>-0,013</sub>	25	28	0,3	0,6
ZKLF1762-2RS-PE	0,45	17	62 <sub>-0,013</sub>	25	30	0,3	0,6
ZKLF2068-2RS-PE	0,61	20	68 <sub>-0,013</sub>	28	34,5	0,3	0,6
ZKLF2575-2RS-PE	0,72	25	75 <sub>-0,013</sub>	28	40,5	0,3	0,6
ZKLF3080-2RS-PE	0,78	30	80 <sub>-0,013</sub>	28	45,5	0,3	0,6
ZKLF3590-2RS-PE	1,13	35	90 <sub>-0,015</sub>	34	52	0,3	0,6
ZKLF40100-2RS-PE	1,46	40	100 <sub>-0,015</sub>	34	58	0,3	0,6
ZKLF50115-2RS-PE	1,86	50	115 <sub>-0,015</sub>	34	72	0,3	0,6

**Performance data**

Designation	Basic load ratings		Fatigue limit load C <sub>u</sub> N	Limiting speeds		Bearing frictional torque M <sub>RL</sub> Nm
	axial dyn. C <sub>a</sub> N	stat. C <sub>0a</sub> N		n <sub>G</sub> grease min <sup>-1</sup>	n <sub>θ</sub> min <sup>-1</sup>	
ZKLF1255-2RS-PE	16 900	24 700	1 090	9 200	3 800	0,16
ZKLF1560-2RS-PE	17 900	28 000	1 240	8 200	3 500	0,2
ZKLF1762-2RS-PE	18 800	31 000	1 380	7 600	3 300	0,24
ZKLF2068-2RS-PE	26 000	47 000	2 070	6 600	3 000	0,3
ZKLF2575-2RS-PE	27 500	55 000	2 450	5 700	2 600	0,4
ZKLF3080-2RS-PE	29 000	64 000	2 800	5 000	2 200	0,5
ZKLF3590-2RS-PE	41 000	89 000	3 950	4 400	2 000	0,6
ZKLF40100-2RS-PE	43 000	101 000	4 450	4 000	1 800	0,7
ZKLF50115-2RS-PE	46 500	126 000	5 600	3 200	1 500	0,9

① Extraction slot; ② Adjacent construction, bearing screw mounted on flat surface; ③ Adjacent construction, bearing screw mounted in bore; ④ Only valid in assembled condition

- The screws are not included in the scope of delivery. Tightening torque in accordance with manufacturer's data. Number of holes in adjacent construction corresponds to t<sub>a</sub>.
- Based on rotating inner ring.
- The recommended INA precision locknuts are not included in the scope of delivery and must be ordered separately.
- The required axial locknut force must be observed when using other locknuts.
- Only valid in conjunction with INA precision locknuts. Note the guidelines on locating/locating bearing arrangements, see page 54.

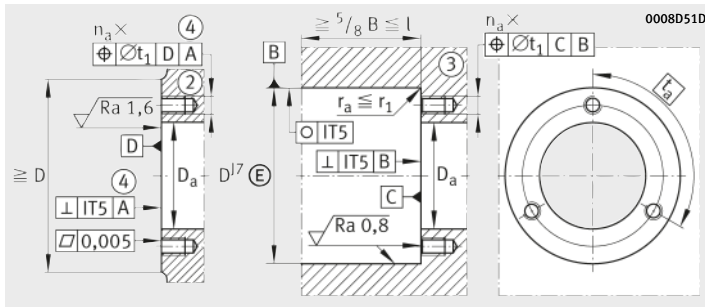

Housing design

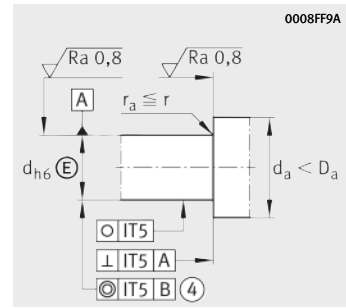

Shaft design  
(threaded spindle)

J	d <sub>2</sub>	b	l	Pitch n×t	Mounting dimensions			Fixing screws <sup>1)</sup> DIN EN ISO 4762 10.9	
					D <sub>a</sub> max.	d <sub>a</sub> min.	t <sub>1</sub>	Size	n <sub>a</sub> ×t <sub>a</sub>
42	6,8	3	17	3×120°	33	16	0,1	M6	3×120°
46	6,8	3	17	3×120°	35	20	0,1	M6	3×120°
48	6,8	3	17	6×60°	37	23	0,1	M6	3×120°
53	6,8	3	19	8×45°	43	25	0,1	M6	4×90°
58	6,8	3	19	8×45°	48	32	0,1	M6	4×90°
63	6,8	3	19	12×30°	53	40	0,1	M6	6×60°
75	8,8	3	25	8×45°	62	45	0,2	M8	4×90°
80	8,8	3	25	8×45°	67	50	0,2	M8	4×90°
94	8,8	3	25	12×30°	82	63	0,2	M8	6×60°

Rigidity axial c <sub>aL</sub> N/μm	Tilting rigidity c <sub>kL</sub>	Mass moment of inertia <sup>2)</sup> M <sub>m</sub>	Axial runout <sup>2)</sup> μm	Recommended INA precision locknut <sup>3)</sup>			Required locknut force <sup>4)</sup> axial N
				For radial locking	For axial locking	Tightening torque <sup>5)</sup> M <sub>A</sub> Nm	
375	50	0,068	5	<b>ZM12</b>	–	8	5 307
400	65	0,102	5	<b>ZM15</b>	<b>AM15</b>	10	5 484
450	80	0,132	5	<b>ZM17</b>	<b>AM17</b>	15	7 514
650	140	0,273	5	<b>ZM20</b>	<b>AM20</b>	18	8 258
750	200	0,486	5	<b>ZM25</b>	<b>AM25</b>	25	9 123
850	300	0,73	5	<b>ZM30</b>	<b>AM30</b>	32	9 947
900	400	1,51	5	<b>ZM35</b>	<b>AM35/58</b>	40	10 770
1 000	550	2,26	5	<b>ZM40</b>	<b>AM40</b>	55	13 412
1 250	1 000	5,24	5	<b>ZM50</b>	<b>AM50</b>	85	16 280

# Axial angular contact ball bearings

For screw mounting  
Matched pair

**X-life**

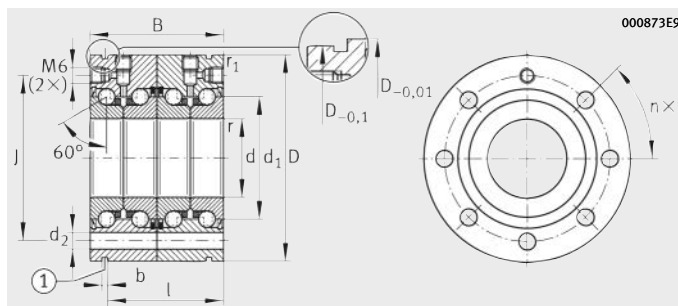

ZKLF.-2RS-2AP

**Dimension table** - Dimensions in mm

Designation	X-life	Mass m ≈ kg	Dimensions					
			d -0,005	D -0,01	B -0,25	d <sub>1</sub>	r min.	r <sub>1</sub> min.
ZKLF1762-2RS-2AP	XL	0,9	17	62	50	30	0,3	0,6
ZKLF2068-2RS-2AP	XL	1,22	20	68	56	34,5	0,3	0,6
ZKLF2575-2RS-2AP	XL	1,44	25	75	56	40,5	0,3	0,6
ZKLF3080-2RS-2AP	XL	1,56	30	80	56	45,5	0,3	0,6
ZKLF3590-2RS-2AP	XL	2,26	35	90	68	52	0,3	0,6
ZKLF40100-2RS-2AP	XL	2,92	40	100	68	58	0,3	0,6
ZKLF50115-2RS-2AP	XL	3,72	50	115	68	72	0,3	0,6

**Performance data**

Designation	X-life	Basic load ratings axial		Fatigue limit load C <sub>u</sub> N	Limiting speeds		Bearing frictional torque M <sub>RL</sub> Nm
		dyn. C <sub>a</sub> N	stat. C <sub>0a</sub> N		n <sub>G</sub> grease min <sup>-1</sup>	n <sub>B</sub> min <sup>-1</sup>	
ZKLF1762-2RS-2AP	XL	33 500	62 000	3 700	7 600	3 300	0,36
ZKLF2068-2RS-2AP	XL	46 000	94 000	5 500	6 600	3 000	0,45
ZKLF2575-2RS-2AP	XL	49 000	111 000	6 500	5 700	2 600	0,6
ZKLF3080-2RS-2AP	XL	52 000	127 000	7 500	5 000	2 200	0,75
ZKLF3590-2RS-2AP	XL	73 000	177 000	10 500	4 400	2 000	0,9
ZKLF40100-2RS-2AP	XL	77 000	202 000	11 900	4 000	1 800	1,05
ZKLF50115-2RS-2AP	XL	83 000	250 000	14 900	3 200	1 500	1,35

Further sizes and designs with seals 2Z available by agreement.

① Extraction slot; ② Adjacent construction, bearing screw mounted on flat surface; ③ Adjacent construction, bearing screw mounted in bore; ④ Only valid in assembled condition; ⑤ Threaded extraction holes, see page 47

- 1) The screws are not included in the scope of delivery. Tightening torque in accordance with manufacturer's data. Number of holes in adjacent construction corresponds to t<sub>a</sub>.
- 2) Based on rotating inner ring.
- 3) The recommended INA precision locknuts are not included in the scope of delivery and must be ordered separately.
- 4) The required axial locknut force must be observed when using other locknuts.
- 5) Only valid in conjunction with INA precision locknuts. Note the guidelines on locating/locating bearing arrangements, see page 54.

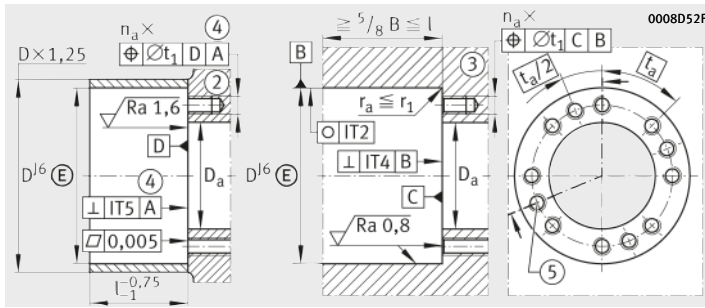

Housing design

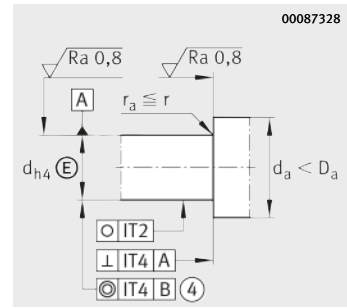

Shaft design  
(threaded spindle)



J	d <sub>2</sub>	b	l	Pitch n×t	Mounting dimensions			Fixing screws <sup>1)</sup> DIN EN ISO 4762 10.9	
					D <sub>a</sub> max.	d <sub>a</sub> min.	t <sub>1</sub>	Size	n <sub>a</sub> ×t <sub>a</sub>
48	6,8	3	42	6×60°	37	23	0,1	M6×60	6×60°
53	6,8	3	47	8×45°	43	25	0,1	M6×70	8×45°
58	6,8	3	47	8×45°	48	32	0,1	M6×70	8×45°
63	6,8	3	47	12×30°	53	40	0,1	M6×70	12×30°
75	8,8	3	59	8×45°	62	45	0,2	M8×80	8×45°
80	8,8	3	59	8×45°	67	50	0,2	M8×80	8×45°
94	8,8	3	59	12×30°	82	63	0,2	M8×80	12×30°

Rigidity axial c <sub>aL</sub> N/μm	Tilting rigidity c <sub>kL</sub>	Mass moment of inertia <sup>2)</sup> M <sub>m</sub>	Axial runout <sup>2)</sup> μm	Recommended INA precision locknut <sup>3)</sup>			Required locknut force <sup>4)</sup> axial N
				For radial locking	For axial locking	Tightening torque <sup>5)</sup> M <sub>A</sub> Nm	
800	200	0,264	2	<b>ZM17</b>	<b>AM17</b>	15	7 514
1 150	320	0,564	2	<b>ZMA20/38</b>	<b>AM20</b>	18	8 258
1 300	450	0,972	2	<b>ZMA25/45</b>	<b>AM25</b>	25	9 123
1 500	620	1,46	2,5	<b>ZMA30/52</b>	<b>AM30</b>	32	9 947
1 600	900	3,02	2,5	<b>ZMA35/58</b>	<b>AM35/58</b>	40	10 770
1 750	1 200	4,52	2,5	<b>ZMA40/62</b>	<b>AM40</b>	55	13 412
2 200	2 250	10,48	2,5	<b>ZMA50/75</b>	<b>AM50</b>	85	16 280

# Axial angular contact ball bearings

Not for screw mounting

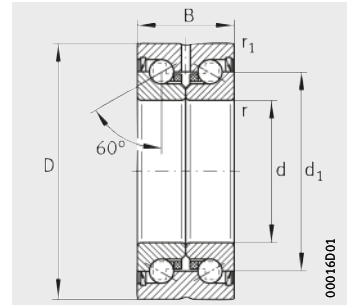

ZKLN...-2RS, ZKLN...-2Z



Dimension table - Dimensions in mm

Designation	X-life	Mass m ≈ kg	Dimensions						Mounting dimensions		Basic load ratings axial	
			d	D	B	d <sub>1</sub>	r	r <sub>1</sub>	D <sub>a</sub>	d <sub>a</sub>	dyn. C <sub>a</sub> N	stat. C <sub>0a</sub> N
ZKLN0619-2Z <sup>5)</sup>	XL	0,02	6 <sup>+0,002</sup> <sub>-0,003</sub>	19	12	12	0,3	0,3	16	9	5 400	6 100
ZKLN0624-2RS	XL	0,03	6 <sup>+0,002</sup> <sub>-0,003</sub>	24	15	14	0,3	0,6	19	9	7 600	8 500
ZKLN0624-2Z	XL	0,03	6 <sup>+0,002</sup> <sub>-0,003</sub>	24	15	14	0,3	0,6	19	9	7 600	8 500
ZKLN0832-2RS	XL	0,09	8 <sub>-0,005</sub>	32	20	19	0,3	0,6	26	11	13 800	16 300
ZKLN0832-2Z	XL	0,09	8 <sub>-0,005</sub>	32	20	19	0,3	0,6	26	11	13 800	16 300
ZKLN1034-2RS	XL	0,1	10 <sub>-0,005</sub>	34	20	21	0,3	0,6	28	14	14 700	18 800
ZKLN1034-2Z	XL	0,1	10 <sub>-0,005</sub>	34	20	21	0,3	0,6	28	14	14 700	18 800
ZKLN1242-2RS	XL	0,2	12 <sub>-0,005</sub>	42	25	25	0,3	0,6	33	16	18 600	24 700
ZKLN1242-2Z	XL	0,2	12 <sub>-0,005</sub>	42	25	25	0,3	0,6	33	16	18 600	24 700
ZKLN1545-2RS	XL	0,21	15 <sub>-0,005</sub>	45	25	28	0,3	0,6	35	20	19 600	28 000
ZKLN1545-2Z	XL	0,21	15 <sub>-0,005</sub>	45	25	28	0,3	0,6	35	20	19 600	28 000
ZKLN1747-2RS	XL	0,22	17 <sub>-0,005</sub>	47	25	30	0,3	0,6	37	23	20 700	31 000
ZKLN1747-2Z	XL	0,22	17 <sub>-0,005</sub>	47	25	30	0,3	0,6	37	23	20 700	31 000
ZKLN2052-2RS	XL	0,31	20 <sub>-0,005</sub>	52	28	34,5	0,3	0,6	43	25	28 500	47 000
ZKLN2052-2Z	XL	0,31	20 <sub>-0,005</sub>	52	28	34,5	0,3	0,6	43	25	28 500	47 000
ZKLN2557-2RS	XL	0,34	25 <sub>-0,005</sub>	57	28	40,5	0,3	0,6	48	32	30 500	55 000
ZKLN2557-2Z	XL	0,34	25 <sub>-0,005</sub>	57	28	40,5	0,3	0,6	48	32	30 500	55 000
ZKLN3062-2RS	XL	0,39	30 <sub>-0,005</sub>	62	28	45,5	0,3	0,6	53	40	32 000	64 000
ZKLN3062-2Z	XL	0,39	30 <sub>-0,005</sub>	62	28	45,5	0,3	0,6	53	40	32 000	64 000
ZKLN3072-2RS <sup>6)</sup>	XL	0,72	30 <sub>-0,005</sub>	72	38	51	0,3	0,6	64	47	65 000	108 000
ZKLN3072-2Z <sup>6)</sup>	XL	0,72	30 <sub>-0,005</sub>	72	38	51	0,3	0,6	64	47	65 000	108 000
ZKLN3572-2RS	XL	0,51	35 <sub>-0,005</sub>	72	34	52	0,3	0,6	62	45	45 000	89 000
ZKLN3572-2Z	XL	0,51	35 <sub>-0,005</sub>	72	34	52	0,3	0,6	62	45	45 000	89 000

④ Only valid in assembled condition

1) Based on rotating inner ring.

2) The recommended INA precision locknuts are not included in the scope of delivery and must be ordered separately.

3) The required axial locknut force must be observed when using other locknuts.

4) Only valid in conjunction with INA precision locknuts. Note the guidelines on locating/locating bearing arrangements, see page 54.

5) No relubrication facility.

6) Heavy series.



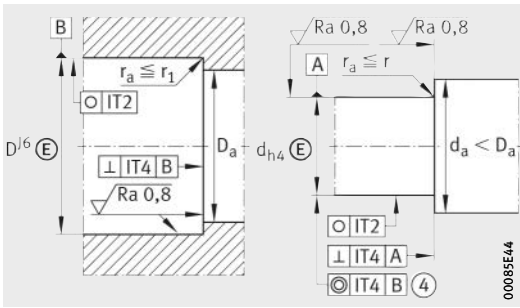

Design of housing and shaft (threaded spindle)

Fatigue limit load  $C_u$  N	Limiting speeds		Bearing frictional torque  $M_{RL}$  Nm	Rigidity axial  $c_{aL}$  N/ $\mu$ m	Tilting rigidity  $c_{kL}$  Nm/mrad	Mass moment of inertia <sup>1)</sup>  $M_m$  kg · cm <sup>2</sup>	Axial run-out <sup>1)</sup>  $\mu$ m	Recommended INA precision locknut <sup>2)</sup>			Required locknut force <sup>3)</sup>  axial  N
	$n_G$ grease min <sup>-1</sup>	$n_\theta$ min <sup>-1</sup>						For radial locking	For axial locking	Tightening torque <sup>4)</sup>  $M_A$  Nm	
360	22 800	14 000	0,01	150	4	0,0019	2	<b>ZM06</b>	–	1	2 010
500	16 400	6 800	0,04	200	8	0,0044	2	<b>ZM06</b>	–	2	2 404
500	19 900	12 000	0,02	200	8	0,0044	2	<b>ZM06</b>	–	2	2 404
960	12 100	5 100	0,08	250	20	0,02	2	<b>ZM08</b>	–	4	3 468
960	15 500	9 500	0,04	250	20	0,02	2	<b>ZM08</b>	–	4	3 468
1 110	10 900	4 600	0,12	325	25	0,029	2	<b>ZM10</b>	–	6	4 891
1 110	14 400	8 600	0,06	325	25	0,029	2	<b>ZM10</b>	–	6	4 891
1 460	9 200	3 800	0,16	375	50	0,068	2	<b>ZM12</b>	–	8	5 307
1 460	12 000	7 600	0,08	375	50	0,068	2	<b>ZM12</b>	–	8	5 307
1 650	8 200	3 500	0,2	400	65	0,102	2	<b>ZM15</b>	<b>AM15</b>	10	5 484
1 650	10 800	7 000	0,1	400	65	0,102	2	<b>ZM15</b>	<b>AM15</b>	10	5 484
1 840	7 600	3 300	0,24	450	80	0,132	2	<b>ZM17</b>	<b>AM17</b>	15	7 514
1 840	10 100	6 600	0,12	450	80	0,132	2	<b>ZM17</b>	<b>AM17</b>	15	7 514
2 750	6 600	3 000	0,3	650	140	0,273	2	<b>ZM20</b>	<b>AM20</b>	18	8 258
2 750	8 700	5 400	0,15	650	140	0,273	2	<b>ZM20</b>	<b>AM20</b>	18	8 258
3 250	5 700	2 600	0,4	750	200	0,486	2	<b>ZM25</b>	<b>AM25</b>	25	9 123
3 250	7 500	4 700	0,2	750	200	0,486	2	<b>ZM25</b>	<b>AM25</b>	25	9 123
3 750	5 000	2 200	0,5	850	300	0,73	2,5	<b>ZM30</b>	<b>AM30</b>	32	9 947
3 750	6 700	4 300	0,25	850	300	0,73	2,5	<b>ZM30</b>	<b>AM30</b>	32	9 947
6 400	4 500	2 100	0,8	950	400	1,91	2,5	<b>ZMA30/52</b>	<b>AM30</b>	65	19 509
6 400	5 600	4 000	0,4	950	400	1,91	2,5	<b>ZMA30/52</b>	<b>AM30</b>	65	19 509
5 200	4 400	2 000	0,6	900	400	1,51	2,5	<b>ZM35</b>	<b>AM35/58</b>	40	10 770
5 200	5 800	3 800	0,3	900	400	1,51	2,5	<b>ZM35</b>	<b>AM35/58</b>	40	10 770



# Axial angular contact ball bearings

Not for screw mounting

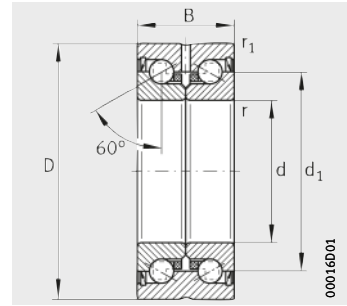

ZKLN...-2RS, ZKLN...-ZZ

Dimension table (continued) · Dimensions in mm

Designation	X-life	Mass m ≈ kg	Dimensions						Mounting dimensions		Basic load ratings axial	
			d	D	B	d <sub>1</sub>	r	r <sub>1</sub>	D <sub>a</sub> max.	d <sub>a</sub> min.	dyn. C <sub>a</sub> N	stat. C <sub>0a</sub> N
ZKLN4075-2RS	XL	0,61	40 <sub>-0,005</sub>	75 <sub>-0,01</sub>	34	58	0,3	0,6	67	50	47 500	101 000
ZKLN4075-ZZ	XL	0,61	40 <sub>-0,005</sub>	75 <sub>-0,01</sub>	34	58	0,3	0,6	67	50	47 500	101 000
ZKLN4090-2RS <sup>5)</sup>	XL	0,95	40 <sub>-0,005</sub>	90 <sub>-0,01</sub>	46	65	0,6	0,6	80	56	79 000	149 000
ZKLN4090-ZZ <sup>5)</sup>	XL	0,95	40 <sub>-0,005</sub>	90 <sub>-0,01</sub>	46	65	0,6	0,6	80	56	79 000	149 000
ZKLN5090-2RS	XL	0,88	50 <sub>-0,005</sub>	90 <sub>-0,01</sub>	34	72	0,3	0,6	82	63	51 000	126 000
ZKLN5090-ZZ	XL	0,88	50 <sub>-0,005</sub>	90 <sub>-0,01</sub>	34	72	0,3	0,6	82	63	51 000	126 000
ZKLN50110-2RS <sup>5)</sup>	XL	2,5	50 <sub>-0,005</sub>	110 <sub>-0,01</sub>	54	80	0,6	0,6	98	63	125 000	250 000
ZKLN50110-ZZ <sup>5)</sup>	XL	2,5	50 <sub>-0,005</sub>	110 <sub>-0,01</sub>	54	80	0,6	0,6	98	63	125 000	250 000
ZKLN60110-ZZ	XL	2,2	60 <sub>-0,008</sub>	110 <sub>-0,015</sub>	45	85	0,6	0,6	100	82	93 000	214 000
ZKLN70120-ZZ	XL	2,4	70 <sub>-0,008</sub>	120 <sub>-0,015</sub>	45	95	0,6	0,6	110	92	97 000	241 000
ZKLN80130-ZZ	XL	2,7	80 <sub>-0,008</sub>	130 <sub>-0,015</sub>	45	105	0,6	0,6	120	102	100 000	265 000
ZKLN90150-ZZ	XL	4,5	90 <sub>-0,008</sub>	150 <sub>-0,015</sub>	55	120	0,6	0,6	138	116	149 000	395 000
ZKLN100160-ZZ	XL	4,9	100 <sub>-0,008</sub>	160 <sub>-0,015</sub>	55	132	0,6	0,6	150	128	154 000	435 000

④ Only valid in assembled condition

- 1) Based on rotating inner ring.
- 2) The recommended INA precision locknuts are not included in the scope of delivery and must be ordered separately.
- 3) The required axial locknut force must be observed when using other locknuts.
- 4) Only valid in conjunction with INA precision locknuts. Note the guidelines on locating/locating bearing arrangements, see page 54.
- 5) Heavy series.

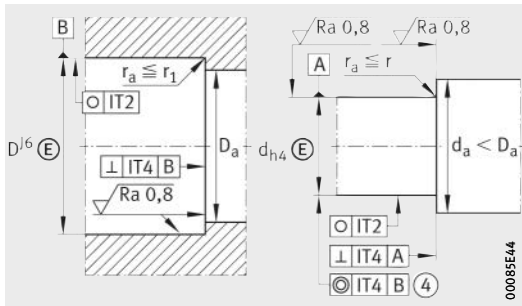

Design of housing and shaft (threaded spindle)



Fatigue limit load	Limiting speeds		Bearing frictional torque	Rigidity axial	Tilting rigidity	Mass moment of inertia <sup>1)</sup>	Axial run-out <sup>1)</sup>	Recommended INA precision locknut <sup>2)</sup>			Required locknut force <sup>3)</sup> axial
								For radial locking	For axial locking	Tightening torque <sup>4)</sup> M <sub>A</sub>	
C <sub>u</sub>	n <sub>G</sub> grease	n <sub>ø</sub>	M <sub>RL</sub>	c <sub>aL</sub>	c <sub>kL</sub>	M <sub>m</sub>			M <sub>A</sub>		
N	min <sup>-1</sup>	min <sup>-1</sup>	Nm	N/μm	Nm/mrad	kg · cm <sup>2</sup>	μm		Nm	N	
6 000	4 000	1 800	0,7	1 000	550	2,26	2,5	<b>ZM40</b>	<b>AM40</b>	55	13 412
6 000	5 200	3 300	0,35	1 000	550	2,26	2,5	<b>ZM40</b>	<b>AM40</b>	55	13 412
8 800	3 500	1 600	1,3	1 200	750	5,5	2,5	<b>ZMA40/62</b>	<b>AM40</b>	110	25 185
8 800	4 400	3 100	0,65	1 200	750	5,5	2,5	<b>ZMA40/62</b>	<b>AM40</b>	110	25 185
7 400	3 200	1 500	0,9	1 250	1 000	5,24	2,5	<b>ZM50</b>	<b>AM50</b>	85	16 280
7 400	4 200	3 000	0,45	1 250	1 000	5,24	2,5	<b>ZM50</b>	<b>AM50</b>	85	16 280
14 800	2 900	1 200	2,6	1 400	1 500	15,2	2,5	<b>ZMA50/75</b>	<b>AM50</b>	150	28 451
14 800	3 500	2 500	1,3	1 400	1 500	15,2	2,5	<b>ZMA50/75</b>	<b>AM50</b>	150	28 451
12 600	4 000	3 000	1	1 300	1 650	13,7	3	<b>ZMA60/98</b>	<b>AM60</b>	100	16 700
14 200	3 800	2 800	1,2	1 450	2 250	19,8	3	<b>ZMA70/110</b>	<b>AM70</b>	130	19 031
15 400	3 600	2 700	1,4	1 600	3 000	27,6	3	<b>ZMA80/120</b>	<b>AM80</b>	160	20 604
21 300	3 500	2 300	2,3	1 700	4 400	59,9	3	<b>ZMA90/130</b>	<b>AM90</b>	200	22 731
22 400	3 300	2 150	2,6	1 900	5 800	85,3	3	<b>ZMA100/140</b>	<b>AM100</b>	250	25 624

# Axial angular contact ball bearings

Not for screw mounting  
Less stringent tolerances

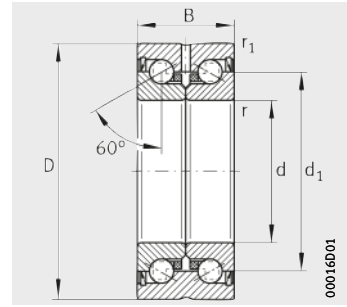

ZKLN...-2RS-PE

**Dimension table** - Dimensions in mm

Designation	Mass m ≈ kg	Dimensions						Mounting dimensions		Basic load ratings axial		Fatigue limit load C <sub>u</sub> N
		d	D	B	d <sub>1</sub>	r	r <sub>1</sub>	D <sub>a</sub> max.	d <sub>a</sub> min.	dyn. C <sub>a</sub> N	stat. C <sub>0a</sub> N	
ZKLN0624-2RS-PE	0,03	6 <sup>+0,003</sup> <sub>-0,005</sub>	24 <sub>-0,01</sub>	15	14	0,3	0,6	19	9	6 900	8 500	375
ZKLN1034-2RS-PE	0,1	10 <sub>-0,008</sub>	34 <sub>-0,011</sub>	20	21	0,3	0,6	28	14	13 400	18 800	830
ZKLN1242-2RS-PE	0,2	12 <sub>-0,01</sub>	42 <sub>-0,011</sub>	25	25	0,3	0,6	33	16	16 900	24 700	1 090
ZKLN1545-2RS-PE	0,21	15 <sub>-0,01</sub>	45 <sub>-0,011</sub>	25	28	0,3	0,6	35	20	17 900	28 000	1 240
ZKLN1747-2RS-PE	0,22	17 <sub>-0,01</sub>	47 <sub>-0,011</sub>	25	30	0,3	0,6	37	23	18 800	31 000	1 380
ZKLN2052-2RS-PE	0,31	20 <sub>-0,01</sub>	52 <sub>-0,013</sub>	28	34,5	0,3	0,6	43	25	26 000	47 000	2 070
ZKLN2557-2RS-PE	0,34	25 <sub>-0,01</sub>	57 <sub>-0,013</sub>	28	40,5	0,3	0,6	48	32	27 500	55 000	2 450
ZKLN3062-2RS-PE	0,39	30 <sub>-0,01</sub>	62 <sub>-0,013</sub>	28	45,5	0,3	0,6	53	40	29 000	64 000	2 800
ZKLN3572-2RS-PE	0,51	35 <sub>-0,01</sub>	72 <sub>-0,013</sub>	34	52	0,3	0,6	62	45	41 000	89 000	3 950
ZKLN5090-2RS-PE	0,88	50 <sub>-0,01</sub>	90 <sub>-0,015</sub>	34	72	0,3	0,6	82	63	46 500	126 000	5 600

④ Only valid in assembled condition

- 1) Based on rotating inner ring.
- 2) The recommended INA precision locknuts are not included in the scope of delivery and must be ordered separately.
- 3) The required axial locknut force must be observed when using other locknuts.
- 4) Only valid in conjunction with INA precision locknuts. Note the guidelines on locating/locating bearing arrangements, see page 54.

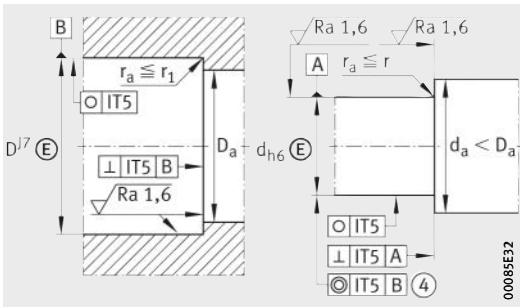

Design of housing and shaft (threaded spindle)



Limiting speeds		Bearing frictional torque	Rigidity axial	Tilting rigidity	Mass moment of inertia <sup>1)</sup>	Axial run-out <sup>1)</sup>	Recommended INA precision locknut <sup>2)</sup>			Required locknut force <sup>3)</sup> axial
$n_G$ grease	$n_{\theta}$						$M_{RL}$	$c_{aL}$	$c_{kL}$	
$\text{min}^{-1}$	$\text{min}^{-1}$	Nm	$\text{N}/\mu\text{m}$	$\text{Nm}/\text{mrad}$	$\text{kg} \cdot \text{cm}^2$	$\mu\text{m}$		$M_A$	N	
16 400	6 800	0,04	200	8	0,0044	5	<b>ZM06</b>	–	2	2 404
10 900	4 600	0,12	325	25	0,029	5	<b>ZM10</b>	–	6	4 891
9 200	3 800	0,16	375	50	0,068	5	<b>ZM12</b>	–	8	5 307
8 200	3 500	0,2	400	65	0,102	5	<b>ZM15</b>	<b>AM15</b>	10	5 484
7 600	3 300	0,24	450	80	0,132	5	<b>ZM17</b>	<b>AM17</b>	15	7 514
6 600	3 000	0,3	650	140	0,273	5	<b>ZM20</b>	<b>AM20</b>	18	8 258
5 700	2 600	0,4	750	200	0,486	5	<b>ZM25</b>	<b>AM25</b>	25	9 123
5 000	2 200	0,5	850	300	0,73	5	<b>ZM30</b>	<b>AM30</b>	32	9 947
4 400	2 000	0,6	900	400	1,51	5	<b>ZM35</b>	<b>AM35/38</b>	40	10 770
3 200	1 500	0,9	1 250	1 000	5,24	5	<b>ZM50</b>	<b>AM50</b>	85	16 280

# Axial angular contact ball bearings

Not for screw mounting  
Matched pair

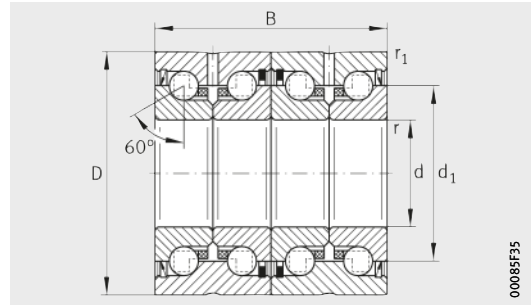

ZKLN..-2RS-2AP



**Dimension table** - Dimensions in mm

Designation	Mass	Dimensions							Mounting dimensions		Basic load ratings axial		Fatigue limit load
		m ≈ kg	d -0,005	D -0,01	B -0,5	d <sub>1</sub>	r min.	r <sub>1</sub> min.	D <sub>a</sub> max.	d <sub>a</sub> min.	dyn. C <sub>a</sub> N	stat. C <sub>0a</sub> N	C <sub>u</sub> N
<b>ZKLN1747-2RS-2AP</b>	<b>XL</b> 0,44	<b>17</b>	47	50	30	0,3	0,6	37	23	33 500	62 000	3 700	
<b>ZKLN2052-2RS-2AP</b>	<b>XL</b> 0,62	<b>20</b>	52	56	34,5	0,3	0,6	43	25	46 000	94 000	5 500	
<b>ZKLN2557-2RS-2AP</b>	<b>XL</b> 0,68	<b>25</b>	57	56	40,5	0,3	0,6	48	32	49 000	111 000	6 500	
<b>ZKLN3062-2RS-2AP</b>	<b>XL</b> 0,78	<b>30</b>	62	56	45,5	0,3	0,6	53	40	52 000	127 000	7 500	
<b>ZKLN3572-2RS-2AP</b>	<b>XL</b> 1,02	<b>35</b>	72	68	52	0,3	0,6	62	45	73 000	177 000	10 500	
<b>ZKLN4075-2RS-2AP</b>	<b>XL</b> 1,22	<b>40</b>	75	68	58	0,3	0,6	67	50	77 000	202 000	11 900	
<b>ZKLN5090-2RS-2AP</b>	<b>XL</b> 1,76	<b>50</b>	90	68	72	0,3	0,6	82	63	83 000	250 000	14 900	

Further sizes and designs with seals 2Z available by agreement.

④ Only valid in assembled condition

- 1) Based on rotating inner ring.
- 2) The recommended INA precision locknuts are not included in the scope of delivery and must be ordered separately.
- 3) The required axial locknut force must be observed when using other locknuts.
- 4) Only valid in conjunction with INA precision locknuts. Note the guidelines on locating/locating bearing arrangements, see page 54.

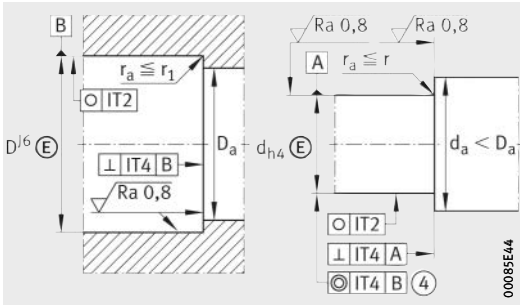

Design of housing and shaft (threaded spindle)



Limiting speeds		Bearing frictional torque $M_{RL}$ Nm	Rigidity axial $c_{aL}$ N/ $\mu$ m	Tilting rigidity $c_{kL}$ Nm/mrad	Mass moment of inertia <sup>1)</sup> $M_m$ kg · cm <sup>2</sup>	Axial run-out <sup>1)</sup> $\mu$ m	Recommended INA precision locknut <sup>2)</sup>			Required locknut force <sup>3)</sup> axial N
$n_G$ grease min <sup>-1</sup>	$n_\theta$ min <sup>-1</sup>						For radial locking	For axial locking	Tightening torque <sup>4)</sup> $M_A$ Nm	
7 600	3 300	0,36	800	200	0,264	2	<b>ZM17</b>	<b>AM17</b>	15	7 514
6 600	3 000	0,45	1 150	320	0,546	2	<b>ZMA20/38</b>	<b>AM20</b>	18	8 258
5 700	2 600	0,6	1 300	450	0,972	2	<b>ZMA25/45</b>	<b>AM25</b>	25	9 123
5 000	2 200	0,75	1 500	620	1,46	2,5	<b>ZMA30/52</b>	<b>AM30</b>	32	9 947
4 400	2 000	0,9	1 600	900	3,02	2,5	<b>ZMA35/58</b>	<b>AM35/58</b>	40	10 770
4 000	1 800	1,05	1 750	1 200	4,52	2,5	<b>ZMA40/62</b>	<b>AM40</b>	55	13 412
3 200	1 500	1,35	2 200	2 250	10,48	2,5	<b>ZMA50/75</b>	<b>AM50</b>	85	16 280

# Axial angular contact ball bearings

Single direction  
Open

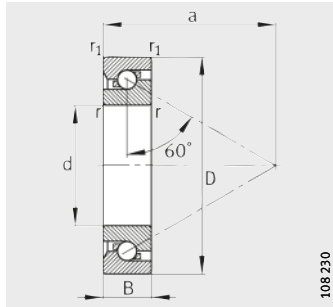

7602, 7603, BSB

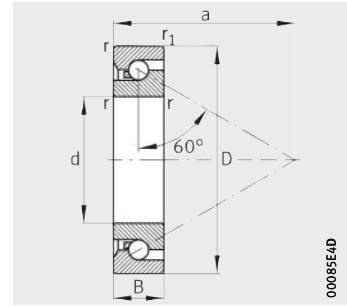

BSB..-SU

**Dimension table** - Dimensions in mm

Designation	Mass m ≈ kg	Dimensions						Mounting dimensions			Basic load ratings axial	
		d	D	B	r	r <sub>1</sub>	a	D <sub>a</sub> H12	d <sub>a</sub> h12	dyn. C <sub>a</sub> N	stat. C <sub>0a</sub> N	
<b>7602012-TVP</b>	0,042	<b>12<sub>-0,004</sub></b>	32 <sub>-0,006</sub>	10 <sub>-0,08</sub>	0,6	0,6	24	27	17	12 200	20 700	
<b>7602015-TVP</b>	0,052	<b>15<sub>-0,004</sub></b>	35 <sub>-0,006</sub>	11 <sub>-0,08</sub>	0,6	0,6	27,5	30	20,5	13 100	24 700	
<b>7602017-TVP</b>	0,074	<b>17<sub>-0,004</sub></b>	40 <sub>-0,006</sub>	12 <sub>-0,08</sub>	0,6	0,6	31	34,5	23	17 200	32 500	
<b>BSB1747-SU</b>	0,13	<b>17<sub>-0,004</sub></b>	47 <sub>-0,006</sub>	15 <sub>-0,12</sub>	1	0,6	29,9	43	27	26 000	47 000	
<b>BSB1747-SU-L055</b>	0,13	<b>17<sub>-0,004</sub></b>	47 <sub>-0,006</sub>	15 <sub>-0,12</sub>	1	0,6	29,9	43	27	26 000	47 000	
<b>7602020-TVP</b>	0,139	<b>20<sub>-0,005</sub></b>	47 <sub>-0,006</sub>	14 <sub>-0,12</sub>	1	1	36	39,5	27,5	19 100	38 000	
<b>BSB2047-SU</b>	0,12	<b>20<sub>-0,005</sub></b>	47 <sub>-0,006</sub>	15 <sub>-0,12</sub>	1	0,6	29,9	43	27	26 000	47 000	
<b>BSB2047-SU-L055</b>	0,12	<b>20<sub>-0,005</sub></b>	47 <sub>-0,006</sub>	15 <sub>-0,12</sub>	1	0,6	29,9	43	27	26 000	47 000	
<b>7603020-TVP</b>	0,17	<b>20<sub>-0,005</sub></b>	52 <sub>-0,007</sub>	15 <sub>-0,12</sub>	1,1	1,1	39,5	43,5	30,5	25 500	53 000	
<b>7602025-TVP</b>	0,147	<b>25<sub>-0,005</sub></b>	52 <sub>-0,007</sub>	15 <sub>-0,12</sub>	1	1	41	45	32	23 200	50 000	
<b>BSB2562-SU</b>	0,24	<b>25<sub>-0,005</sub></b>	62 <sub>-0,007</sub>	15 <sub>-0,12</sub>	1	0,6	39,4	54	38	29 000	64 000	
<b>BSB2562-SU-L055</b>	0,24	<b>25<sub>-0,005</sub></b>	62 <sub>-0,007</sub>	15 <sub>-0,12</sub>	1	0,6	39,4	54	38	29 000	64 000	
<b>7603025-TVP</b>	0,275	<b>25<sub>-0,005</sub></b>	62 <sub>-0,007</sub>	17 <sub>-0,12</sub>	1,1	1,1	47,5	52	38	29 500	68 000	
<b>BSB3062-SU</b>	0,22	<b>30<sub>-0,005</sub></b>	62 <sub>-0,007</sub>	15 <sub>-0,12</sub>	1	0,6	39,4	54	38	29 000	64 000	
<b>BSB3062-SU-L055</b>	0,22	<b>30<sub>-0,005</sub></b>	62 <sub>-0,007</sub>	15 <sub>-0,12</sub>	1	0,6	39,4	54	38	29 000	64 000	
<b>7602030-TVP</b>	0,232	<b>30<sub>-0,005</sub></b>	62 <sub>-0,007</sub>	16 <sub>-0,12</sub>	1	1	48	52,5	39,5	27 500	66 000	
<b>7603030-TVP</b>	0,409	<b>30<sub>-0,005</sub></b>	72 <sub>-0,007</sub>	19 <sub>-0,12</sub>	1,1	1,1	55,5	61	45	36 500	89 000	

④ Only valid in assembled condition

- 1) Valid for single bearings with stated preload.
- 2) Valid for matched pair of bearings in O or X arrangement.
- 3) Based on rotating inner ring.
- 4) The recommended INA precision locknuts are not included in the scope of delivery and must be ordered separately.
- 5) The required axial locknut force must be observed when using other locknuts.
- 6) Only valid in conjunction with INA precision locknuts. Note the guidelines on locating/locating bearing arrangements, see page 54.



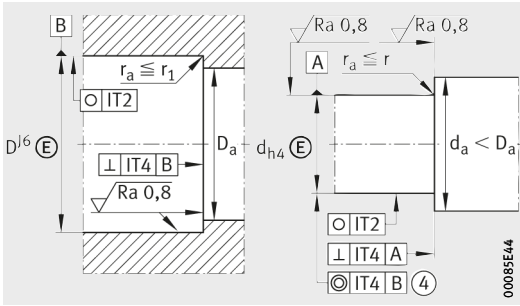

Design of housing and shaft (threaded spindle)

Fatigue limit load  $C_u$  N	Limiting speeds		Bearing frictional torque <sup>1)</sup>		Rigidity <sup>2)</sup> axial $C_{aL}$	Axial run-out <sup>3)</sup> $\mu\text{m}$	Recommended INA precision locknut <sup>4)</sup>			Required locknut force <sup>5)</sup> axial N
			lightly oiled $M_{RL}$	greased $M_{RL}$			For radial locking	For axial locking	Tightening torque <sup>6)</sup> $M_A$	
	$n_G$ grease $\text{min}^{-1}$	$n_\theta$ $\text{min}^{-1}$	Nm	Nm	N/ $\mu\text{m}$	Nm				N
920	14 100	8 000	0,015	–	476	2	ZM12	–	8	6 110
1 090	12 300	6 700	0,02	–	516	2	ZM15	AM15	10	5 740
1 430	10 600	6 000	0,03	–	596	2	ZM17	AM17	15	8 060
2 070	8 700	6 200	–	0,2	764	2	ZM17	AM17	15	9 000
2 070	8 700	6 200	–	0,2	764	2	ZM17	AM17	15	9 000
1 670	9 200	5 000	0,05	–	703	2	ZM20	AM20	18	8 490
2 070	8 700	6 200	–	0,2	764	2	ZM20	AM20	18	9 000
2 070	8 700	6 200	–	0,2	764	2	ZM20	AM20	18	9 000
2 360	8 200	4 500	0,06	–	787	2	ZM20	AM20	25	11 600
2 220	8 000	4 500	0,065	–	772	2	ZM25	AM25	25	9 430
2 800	6 700	5 400	–	0,25	1 001	2	ZMA25/45	AM25	30	11 810
2 800	6 700	5 400	–	0,25	1 001	2	ZMA25/45	AM25	30	11 810
3 000	6 800	3 800	0,085	–	917	2	ZM25	AM25	40	14 480
2 800	6 700	5 400	–	0,25	1 034	2,5	ZM30	AM30	32	11 080
2 800	6 700	5 400	–	0,25	1 034	2,5	ZM30	AM30	32	11 080
2 900	6 700	3 800	0,085	–	893	2	ZM30	AM30	32	10 240
3 950	5 700	3 200	0,13	–	1 073	2	ZM30	AM30	55	16 180



# Axial angular contact ball bearings

Single direction  
Open

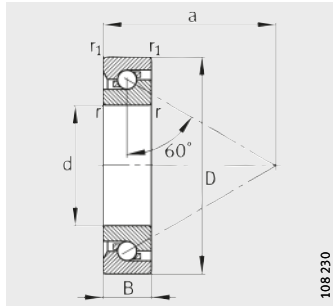

7602, 7603, BSB

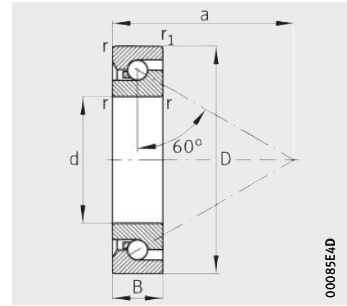

BSB..-SU

Dimension table (continued) · Dimensions in mm

Designation	Mass m ≈ kg	Dimensions						Mounting dimensions			Basic load ratings axial	
		d	D	B	r	r <sub>1</sub>	a	D <sub>a</sub> H12	d <sub>a</sub> h12	dyn. C <sub>a</sub> N	stat. C <sub>0a</sub> N	
<b>BSB3572-SU</b>	0,3	<b>35<sub>-0,006</sub></b>	72 <sub>-0,007</sub>	15 <sub>-0,12</sub>	1	0,6	48,5	65	47	37 000	89 000	
<b>BSB3572-SU-L055</b>	0,3	<b>35<sub>-0,006</sub></b>	72 <sub>-0,007</sub>	15 <sub>-0,12</sub>	1	0,6	48,5	65	47	37 000	89 000	
<b>7602035-TVP</b>	0,339	<b>35<sub>-0,006</sub></b>	72 <sub>-0,007</sub>	17 <sub>-0,12</sub>	1,1	1,1	55	60,5	46,5	31 500	81 000	
<b>7603035-TVP</b>	0,546	<b>35<sub>-0,006</sub></b>	80 <sub>-0,007</sub>	21 <sub>-0,12</sub>	1,5	1,5	61,5	67	51	38 000	100 000	
<b>BSB4072-SU</b>	0,26	<b>40<sub>-0,006</sub></b>	72 <sub>-0,007</sub>	15 <sub>-0,12</sub>	1	0,6	48,5	65	47	37 000	89 000	
<b>BSB4072-SU-L055</b>	0,26	<b>40<sub>-0,006</sub></b>	72 <sub>-0,007</sub>	15 <sub>-0,12</sub>	1	0,6	48,5	65	47	37 000	89 000	
<b>7602040-TVP</b>	0,418	<b>40<sub>-0,006</sub></b>	80 <sub>-0,007</sub>	18 <sub>-0,12</sub>	1,1	1,1	62,5	69,5	53,5	39 000	106 000	
<b>BSB040090-T</b>	0,65	<b>40<sub>-0,006</sub></b>	90 <sub>-0,008</sub>	20 <sub>-0,12</sub>	1,5	1,5	67	75,5	56,5	52 000	138 000	
<b>7603040-TVP</b>	0,751	<b>40<sub>-0,006</sub></b>	90 <sub>-0,008</sub>	23 <sub>-0,12</sub>	1,5	1,5	68,5	75,5	56,5	52 000	138 000	
<b>BSB045075-T</b>	0,26	<b>45<sub>-0,006</sub></b>	75 <sub>-0,007</sub>	15 <sub>-0,12</sub>	1	1	59,5	68	52	30 000	85 000	
<b>7602045-TVP</b>	0,488	<b>45<sub>-0,006</sub></b>	85 <sub>-0,008</sub>	19 <sub>-0,12</sub>	1,1	1,1	66	73	57	39 500	111 000	
<b>BSB045100-T</b>	0,81	<b>45<sub>-0,006</sub></b>	100 <sub>-0,008</sub>	20 <sub>-0,12</sub>	1,5	1,5	75	85,5	64,5	62 000	172 000	
<b>7603045-TVP</b>	0,992	<b>45<sub>-0,006</sub></b>	100 <sub>-0,008</sub>	25 <sub>-0,12</sub>	1,5	1,5	77,5	85,5	64,5	62 000	172 000	
<b>7602050-TVP</b>	0,557	<b>50<sub>-0,006</sub></b>	90 <sub>-0,008</sub>	20 <sub>-0,12</sub>	1,1	1,1	71,5	79	63	41 000	122 000	
<b>BSB050100-T</b>	0,75	<b>50<sub>-0,006</sub></b>	100 <sub>-0,008</sub>	20 <sub>-0,12</sub>	1,5	1,5	75	85,5	64,5	62 000	172 000	
<b>7603050-TVP</b>	1,29	<b>50<sub>-0,006</sub></b>	110 <sub>-0,008</sub>	27 <sub>-0,12</sub>	2	2	85,5	94	72	72 000	203 000	
<b>BSB055090-T</b>	0,38	<b>55<sub>-0,007</sub></b>	90 <sub>-0,008</sub>	15 <sub>-0,15</sub>	1,0	1,0	70,5	80	65	33 500	98 000	
<b>7602055-TVP</b>	0,74	<b>55<sub>-0,007</sub></b>	100 <sub>-0,008</sub>	21 <sub>-0,15</sub>	1,5	1,5	77,5	85,5	69,5	42 000	132 000	
<b>BSB055120-T<sup>7)</sup></b>	1,2	<b>55<sub>-0,007</sub></b>	120 <sub>-0,008</sub>	20 <sub>-0,15</sub>	2,0	2,0	86	97,5	77	63 000	188 000	
<b>7603055-TVP<sup>7)</sup></b>	1,67	<b>55<sub>-0,007</sub></b>	120 <sub>-0,008</sub>	29 <sub>-0,15</sub>	2	2	91,5	101	77	85 000	255 000	
<b>BSB060120-T</b>	1,1	<b>60<sub>-0,007</sub></b>	120 <sub>-0,008</sub>	20 <sub>-0,15</sub>	1,5	1,5	88	100,5	79,5	64 000	196 000	

④ Only valid in assembled condition

1) Valid for single bearings with stated preload.

2) Valid for matched pair of bearings in O or X arrangement.

3) Based on rotating inner ring.

4) The recommended INA precision locknuts are not included in the scope of delivery and must be ordered separately.

5) The required axial locknut force must be observed when using other locknuts.

6) Only valid in conjunction with INA precision locknuts. Note the guidelines on locating/locating bearing arrangements, see page 54.

7) Delivery possibility by agreement.

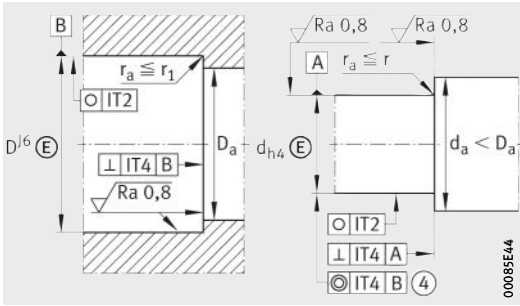

Design of housing and shaft (threaded spindle)



Fatigue limit load $C_u$ N	Limiting speeds		Bearing frictional torque <sup>1)</sup>		Rigidity <sup>2)</sup> axial $C_{aL}$ N/ $\mu$ m	Axial run-out <sup>3)</sup> $\mu$ m	Recommended INA precision locknut <sup>4)</sup>			Required locknut force <sup>5)</sup> axial N
			lightly oiled $M_{RL}$ Nm	greased $M_{RL}$ Nm			For radial locking	For axial locking	Tightening torque <sup>6)</sup> $M_A$ Nm	
	$n_G$ grease $\text{min}^{-1}$	$n_B$ $\text{min}^{-1}$								
3 950	5 400	4 700	–	0,35	1 196	2,5	<b>ZM35</b>	<b>AM35</b>	50	15 220
3 950	5 400	4 700	–	0,35	1 196	2,5	<b>ZM35</b>	<b>AM35</b>	50	15 220
3 600	5 700	3 200	0,115	–	1 020	2	<b>ZM35</b>	<b>AM35</b>	40	11 310
4 450	5 100	3 000	0,17	–	1 192	2	<b>ZM35</b>	<b>AM35</b>	65	17 380
3 950	5 400	4 700	–	0,35	1 235	2,5	<b>ZM40</b>	<b>AM40</b>	60	15 650
3 950	5 400	4 700	–	0,35	1 235	2,5	<b>ZM40</b>	<b>AM40</b>	60	15 650
4 650	4 900	2 800	0,17	–	1 190	2	<b>ZM40</b>	<b>AM40</b>	55	13 330
6 100	4 500	3 100	0,225	–	1 292	2	<b>ZM40</b>	<b>AM40</b>	110	25 120
6 100	4 500	2 600	0,225	–	1 292	2	<b>ZM40</b>	<b>AM40</b>	110	25 120
3 750	5 100	3 300	0,13	–	1 072	2	<b>ZM45</b>	<b>AM45</b>	50	11 140
4 900	4 700	2 600	0,19	–	1 247	2	<b>ZM45</b>	<b>AM45</b>	65	14 410
7 600	4 000	2 700	0,3	–	1 473	2	<b>ZM45</b>	<b>AM45</b>	120	25 160
7 600	4 000	2 200	0,3	–	1 473	2	<b>ZM45</b>	<b>AM45</b>	120	25 160
5 400	4 300	2 400	0,23	–	1 360	2	<b>ZM50</b>	<b>AM50</b>	85	16 810
7 600	4 000	2 700	0,33	–	1 473	2	<b>ZM50</b>	<b>AM50</b>	120	23 770
9 000	3 600	2 000	0,36	–	1 601	2	<b>ZM50</b>	<b>AM50</b>	150	28 930
4 300	4 200	2 800	0,19	–	1 246	3	<b>ZM55</b>	<b>AM55</b>	60	12 040
5 800	3 900	2 200	0,25	–	1 394	3	<b>ZM55</b>	<b>AM55</b>	85	15 060
8 300	3 400	2 400	0,36	–	1 553	3	<b>ZM55</b>	<b>AM55</b>	110	20 070
11 200	3 300	1 900	0,46	–	1 723	3	<b>ZM55</b>	<b>AM55</b>	130	24 120
8 700	3 800	2 300	0,38	–	1 623	3	<b>ZM60</b>	<b>AM60</b>	120	20 020

# Axial angular contact ball bearings

Single direction  
Sealed on both sides

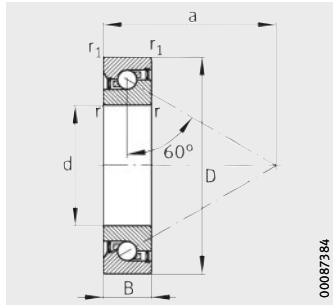

7602...-2RS, 7603...-2RS,  
BSB...-2RS

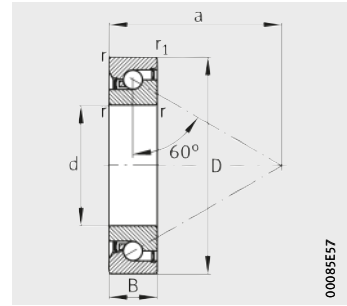

BSB...-2Z-SU

**Dimension table** - Dimensions in mm

Designation	Mass m ≈ kg	Dimensions						Mounting dimensions			Basic load ratings axial	
		d	D	B	r, min.	r <sub>1</sub> min.	a ≈	D <sub>a</sub> H12	d <sub>a</sub> h12	dyn. C <sub>a</sub> N	stat. C <sub>0a</sub> N	
<b>7602012-2RS-TVP</b>	0,042	<b>12</b> <sub>-0,004</sub>	32 <sub>-0,006</sub>	10 <sub>-0,08</sub>	0,6	0,6	24	27	17	12 200	20 700	
<b>7602015-2RS-TVP</b>	0,052	<b>15</b> <sub>-0,004</sub>	35 <sub>-0,006</sub>	11 <sub>-0,08</sub>	0,6	0,6	27,5	30	20,5	13 100	24 700	
<b>BSB1747-2Z-SU</b>	0,13	<b>17</b> <sub>-0,004</sub>	47 <sub>-0,006</sub>	15 <sub>-0,12</sub>	1	0,6	29,9	43	27	26 000	47 000	
<b>7602020-2RS-TVP</b>	0,12	<b>20</b> <sub>-0,005</sub>	47 <sub>-0,006</sub>	14 <sub>-0,12</sub>	1	1	36	39,5	27,5	19 100	38 000	
<b>BSB2047-2Z-SU</b>	0,12	<b>20</b> <sub>-0,005</sub>	47 <sub>-0,006</sub>	15 <sub>-0,12</sub>	1	0,6	29,9	43	27	26 000	47 000	
<b>7603020-2RS-TVP</b>	0,17	<b>20</b> <sub>-0,005</sub>	52 <sub>-0,007</sub>	15 <sub>-0,12</sub>	1,1	1,1	36,5	43,5	30,5	25 500	53 000	
<b>7602025-2RS-TVP</b>	0,15	<b>25</b> <sub>-0,005</sub>	52 <sub>-0,007</sub>	15 <sub>-0,12</sub>	1	1	41	45	32	23 200	50 000	
<b>BSB2562-2Z-SU</b>	0,24	<b>25</b> <sub>-0,005</sub>	62 <sub>-0,007</sub>	15 <sub>-0,12</sub>	1	0,6	39,4	54	38	29 000	64 000	
<b>7603025-2RS-TVP</b>	0,27	<b>25</b> <sub>-0,005</sub>	62 <sub>-0,007</sub>	17 <sub>-0,12</sub>	1,1	1,1	47,5	52	38	29 500	68 000	
<b>BSB3062-2Z-SU</b>	0,22	<b>30</b> <sub>-0,005</sub>	62 <sub>-0,007</sub>	15 <sub>-0,12</sub>	1	0,6	39,4	54	38	29 000	64 000	
<b>7602030-2RS-TVP</b>	0,23	<b>30</b> <sub>-0,005</sub>	62 <sub>-0,007</sub>	16 <sub>-0,12</sub>	1	1	48	52,5	39,5	27 500	66 000	
<b>BSB3572-2Z-SU</b>	0,3	<b>35</b> <sub>-0,006</sub>	72 <sub>-0,007</sub>	15 <sub>-0,12</sub>	1	0,6	48,5	65	47	37 000	89 000	
<b>BSB4072-2Z-SU</b>	0,26	<b>40</b> <sub>-0,006</sub>	72 <sub>-0,007</sub>	15 <sub>-0,12</sub>	1	0,6	48,5	65	47	37 000	89 000	

④ Only valid in assembled condition

- 1) Valid for single bearings with stated preload.
- 2) Valid for matched pair of bearings in O or X arrangement.
- 3) Based on rotating inner ring.
- 4) The recommended INA precision locknuts are not included in the scope of delivery and must be ordered separately.
- 5) The required axial locknut force must be observed when using other locknuts.
- 6) Only valid in conjunction with INA precision locknuts. Note the guidelines on locating/locating bearing arrangements, see page 54.

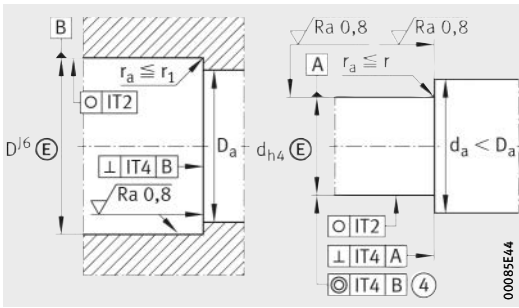

Design of housing and shaft (threaded spindle)



Fatigue limit load	Limiting speeds		Bearing frictional torque <sup>1)</sup>	Rigidity <sup>2)</sup>	Axial runout <sup>3)</sup>	Recommended INA precision locknut <sup>4)</sup>			Required locknut force <sup>5)</sup>
						axial	For radial locking	For axial locking	
$C_u$	$n_G$ grease	$n_B$	$M_{RL}$	$c_{aL}$	$\mu m$			$M_A$	
N	min <sup>-1</sup>	min <sup>-1</sup>	Nm	N/ $\mu m$	$\mu m$			Nm	N
920	10 400	8 000	0,018	476	2	<b>ZM12</b>	<b>AM12</b>	8	6 110
1 090	9 000	6 700	0,024	516	2	<b>ZM15</b>	<b>AM15</b>	10	5 740
2 750	8 700	6 200	0,2	764	2	<b>ZM20</b>	<b>AM20</b>	18	9 000
1 670	6 800	5 000	0,06	703	2	<b>ZM20</b>	<b>AM20</b>	18	8 490
2 070	8 700	6 200	0,2	764	2	<b>ZM20</b>	<b>AM20</b>	18	9 000
2 360	6 200	4 500	0,07	787	2	<b>ZM20</b>	<b>AM20</b>	18	11 600
2 220	5 100	3 800	0,08	772	2	<b>ZM25</b>	<b>AM25</b>	25	9 430
2 800	6 700	5 400	0,25	1 001	2	<b>ZMA25/45</b>	<b>AM25</b>	30	11 810
3 000	5 100	3 800	0,1	917	2	<b>ZM25</b>	<b>AM25</b>	40	14 480
2 800	6 700	5 400	0,25	1 034	2,5	<b>ZM30</b>	<b>AM30</b>	32	11 080
2 900	5 000	3 800	0,1	893	2	<b>ZM30</b>	<b>AM30</b>	32	10 240
3 950	5 400	4 700	0,35	1 196	2,5	<b>ZM35</b>	<b>AM35</b>	50	15 220
3 950	5 400	4 700	0,35	1 235	2,5	<b>ZM40</b>	<b>AM40</b>	60	15 650

# Angular contact ball bearing units

For screw mounting

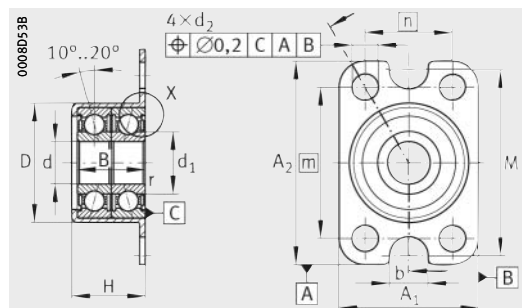

ZKLR0624-2Z, ZKLR0828-2Z

**Dimension table** - Dimensions in mm

Designation	Mass m ≈ kg	Dimensions							
		d	A <sub>1</sub>	A <sub>2</sub>	D +0,03 -0,01	B ±0,25	d <sub>1</sub>	r min.	d <sub>2</sub>
<b>ZKLR0624-2Z</b>	0,023	<b>6<sub>-0,008</sub></b>	24	35	20,5	12	9	0,3	4,5
<b>ZKLR0828-2Z</b>	0,03	<b>8<sub>-0,008</sub></b>	28	35	23,9	14	11	0,3	4,5
<b>ZKLR1035-2Z</b>	0,05	<b>10<sub>-0,008</sub></b>	35	35	28,14	16	13,55	0,3	4,5
<b>ZKLR1244-2RS</b>	0,12	<b>12<sub>-0,007</sub></b>	44	50	35,45	20	16,6	0,3	6,6
<b>ZKLR1547-2RS</b>	0,14	<b>15<sub>-0,007</sub></b>	47	51	38,45	22	18	0,3	6,6
<b>ZKLR2060-2RS</b>	0,3	<b>20<sub>-0,008</sub></b>	60	60	50,45	28	24,4	0,3	6,6

**Performance data**

Designation	Basic load ratings				Fatigue limit load C <sub>u</sub> N	Limiting speed n <sub>G</sub> grease min <sup>-1</sup>
	radial		axial			
	dyn. C <sub>r</sub> N	stat. C <sub>0r</sub> N	dyn. C <sub>a</sub> N	stat. C <sub>0a</sub> N		
<b>ZKLR0624-2Z</b>	4 100	2 060	1 650	1 520	104	7 300
<b>ZKLR0828-2Z</b>	5 000	2 700	2 060	1 850	138	6 200
<b>ZKLR1035-2Z</b>	7 000	3 900	2 430	2 420	197	5 100
<b>ZKLR1244-2RS</b>	13 600	8 500	13 200	17 900	430	3 700
<b>ZKLR1547-2RS</b>	16 700	10 700	16 400	22 400	540	3 400
<b>ZKLR2060-2RS</b>	28 000	19 100	27 500	40 000	970	2 800

② Adjacent construction, bearing screw mounted on flat surface; ④ Only valid in assembled condition

1) The screws are not included in the scope of delivery.  
Tightening torque according to manufacturer's data.

2) Statistically determined mean values from measurements on the complete bearing. Due to the specific design, larger fluctuations in rigidity should be expected with axial angular contact ball bearing units ZKLR.

3) Based on rotating inner ring.

4) The locknut is only used to axially locate the bearing unit. It has no influence on the bearing preload.

5) The recommended INA precision locknuts are not included in the scope of delivery and must be ordered separately.

6) Only valid in conjunction with INA precision locknuts.

7) The geometrical tolerances stated are only required in the area of the diameter between D<sub>ai</sub> and D<sub>aa</sub>.

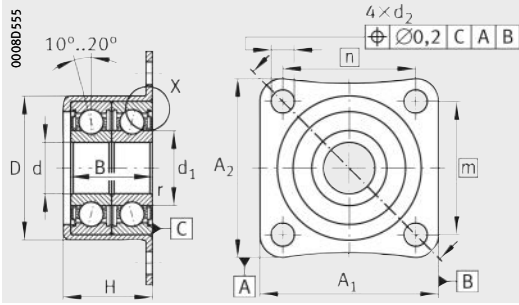

ZKLR1035-2Z

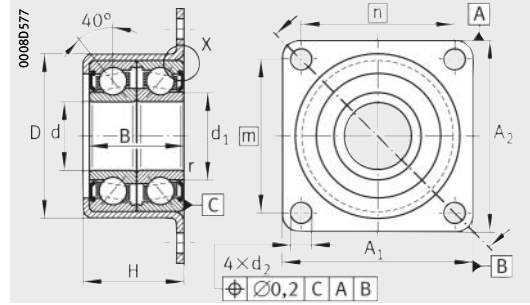

ZKLR1244-2RS, ZKLR1547-2RS, ZKLR2060-2RS

b	m	n	M	H	d <sub>a</sub>	D <sub>ai</sub>	D <sub>aa</sub>	Fixing screws <sup>1)</sup> DIN EN ISO 4762		
				-0,5				Size	n	t <sub>1</sub>
6,6	26	15	32	13	8	16	19	M4 M6	4 2	0,2
6,6	26	20	35	15,5	10,4	18	22	M4 M6	4 2	0,2
-	26	26	-	17,5	12,4	22	26	M4	4	0,2
-	38	32	-	22	14	27	32	M6	4	0,2
-	39	35	-	24	17,5	29	35	M6	4	0,2
-	47	47	-	30	24	39	47	M6	4	0,2

Bearing frictional torque	Rigidity <sup>2)</sup> axial	Mass moment of inertia <sup>3)</sup>	Axial runout <sup>3)</sup>	Recommended INA precision locknut <sup>4)5)</sup>		
				For radial locking	For axial locking	Tightening torque <sup>6)</sup>
M <sub>RL</sub>	c <sub>aL</sub>	M <sub>m</sub>				M <sub>A</sub>
Nm	N/μm	kg · cm <sup>2</sup>	μm			Nm
0,04	14	0,0014	7	<b>ZM06</b>	-	2
0,08	16	0,0028	7	<b>ZM08</b>	-	4
0,12	19	0,0075	7	<b>ZM10</b>	-	6
0,16	170	0,0102	7	<b>ZM12</b>	-	8
0,2	200	0,0178	7	<b>ZM15</b>	<b>AM15</b>	10
0,3	250	0,263	8	<b>ZM20</b>	<b>AM20</b>	18

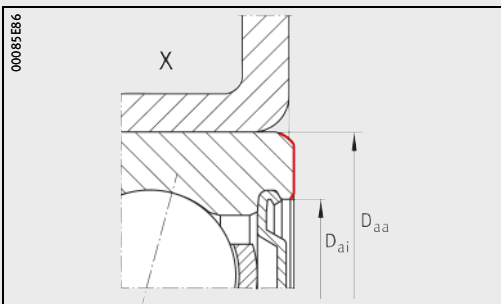

Axial abutment area of outer ring

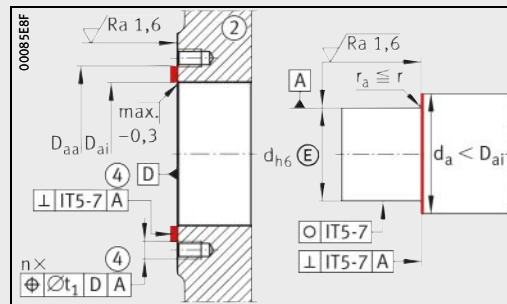

Design of housing and shaft<sup>7)</sup>

# Double row axial angular contact ball bearings with flange

For screw mounting

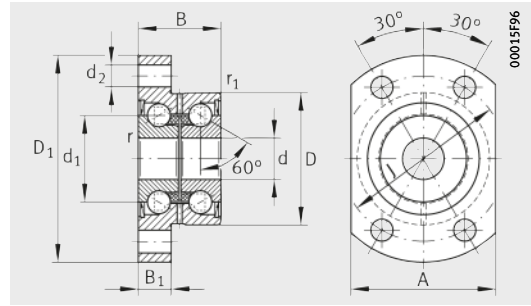

ZKLFA...-2RS, ZKLFA...-2Z

**Dimension table** - Dimensions in mm

Designation	Mass m ≈ kg	Dimensions					
		d	D -0,01	B -0,25	d <sub>1</sub>	D <sub>1</sub>	r min.
ZKLFA0630-2Z <sup>2)</sup>	0,05	6 <sup>+0,002</sup> <sub>-0,003</sub>	19	12	12	30	0,3
ZKLFA0640-2RS	0,08	6 <sup>+0,002</sup> <sub>-0,003</sub>	24	15	14	40	0,3
ZKLFA0640-2Z	0,08	6 <sup>+0,002</sup> <sub>-0,003</sub>	24	15	14	40	0,3
ZKLFA0850-2RS	0,17	8 <sup>0</sup> <sub>-0,005</sub>	32	20	19	50	0,3
ZKLFA0850-2Z	0,17	8 <sup>0</sup> <sub>-0,005</sub>	32	20	19	50	0,3

**Performance data**

Designation	Basic load ratings		Fatigue limit load C <sub>u</sub> N	Limiting speeds		Bearing frictional torque M <sub>RL</sub> Nm
	axial			n <sub>G grease</sub> min <sup>-1</sup>	n <sub>ø</sub> min <sup>-1</sup>	
	dyn. C <sub>a</sub> N	stat. C <sub>0a</sub> N				
ZKLFA0630-2Z <sup>2)</sup>	4 900	6 100	270	22 800	14 000	0,01
ZKLFA0640-2RS	6 900	8 500	375	16 400	6 800	0,04
ZKLFA0640-2Z	6 900	8 500	375	19 900	12 000	0,02
ZKLFA0850-2RS	12 500	16 300	720	12 100	5 100	0,08
ZKLFA0850-2Z	12 500	16 300	720	15 500	9 500	0,04

② Adjacent construction, bearing screw mounted on flat surface; ④ Only valid in assembled condition

1) The screws are not included in the scope of delivery. Tightening torque according to manufacturer's data.

2) No relubrication facility.

3) Based on rotating inner ring.

4) The recommended INA precision locknuts are not included in the scope of delivery and must be ordered separately.

5) The required axial locknut force must be observed when using other locknuts.

6) Only valid in conjunction with INA precision locknuts. Note the guidelines on locating/locating bearing arrangements, see page 54.



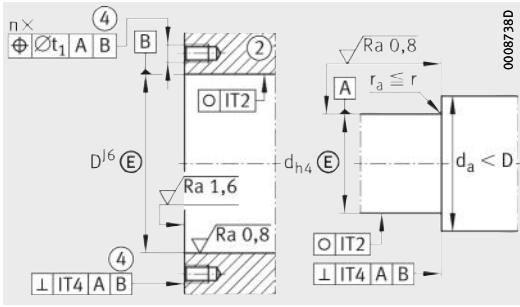

Design of housing and shaft (threaded spindle)



					Mounting dimensions			Fixing screws <sup>1)</sup> DIN EN ISO 4762 10.9	
r <sub>1</sub> min.	B <sub>1</sub>	d <sub>2</sub>	J	A	d <sub>a</sub>		t <sub>1</sub>	Size	n
					min.	max.			
0,3	5	3,5	24	22	9	15	0,1	M3	4
0,6	6	4,5	32	27	9	18	0,1	M4	4
0,6	6	4,5	32	27	9	18	0,1	M4	4
0,6	8	5,5	40	35	11	25	0,1	M5	4
0,6	8	5,5	40	35	11	25	0,1	M5	4

Rigidity  axial c <sub>aL</sub> N/μm	Tilting rigidity c <sub>kL</sub> Nm/ mrad	Mass moment of inertia <sup>3)</sup> M <sub>m</sub> kg · cm <sup>2</sup>	Axial runout <sup>3)</sup> μm	Recommended INA precision locknut <sup>4)</sup>			Required locknut force <sup>5)</sup> axial N
				For radial locking	For axial locking	Tightening torque <sup>6)</sup> M <sub>A</sub> Nm	
150	4	0,0019	2	<b>ZM06</b>	–	2	2 010
200	8	0,0044	2	<b>ZM06</b>	–	2	2 404
200	8	0,0044	2	<b>ZM06</b>	–	2	2 404
250	20	0,02	2	<b>ZM08</b>	–	4	3 468
250	20	0,02	2	<b>ZM08</b>	–	4	3 468

# Double row axial angular contact ball bearings with flange

For screw mounting

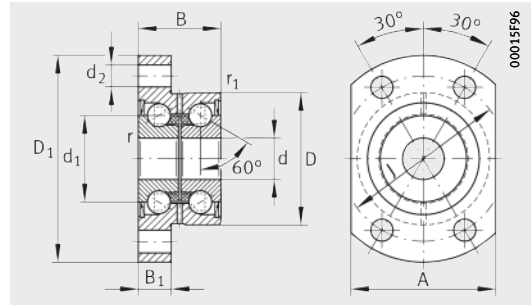

ZKLFA..-2RS, ZKLFA..-2Z

**Dimension table** (continued) · Dimensions in mm

Designation	Mass m ≈ kg	Dimensions					
		d -0,005	D -0,01	B -0,25	d <sub>1</sub>	D <sub>1</sub>	r min.
<b>ZKLFA1050-2RS</b>	0,18	<b>10</b>	32	20	21	50	0,3
<b>ZKLFA1050-2Z</b>	0,18	<b>10</b>	32	20	21	50	0,3
<b>ZKLFA1263-2RS</b>	0,3	<b>12</b>	42	25	25	63	0,3
<b>ZKLFA1263-2Z</b>	0,3	<b>12</b>	42	25	25	63	0,3
<b>ZKLFA1563-2RS</b>	0,31	<b>15</b>	42	25	28	63	0,3
<b>ZKLFA1563-2Z</b>	0,31	<b>15</b>	42	25	28	63	0,3

**Performance data**

Designation	Basic load ratings		Fatigue limit load C <sub>u</sub> N	Limiting speeds		Bearing frictional torque M <sub>RL</sub> Nm
	axial			n <sub>G</sub> grease min <sup>-1</sup>	n <sub>ø</sub> min <sup>-1</sup>	
	dyn. C <sub>a</sub> N	stat. C <sub>0a</sub> N				
<b>ZKLFA1050-2RS</b>	13 400	18 800	830	10 900	4 600	0,12
<b>ZKLFA1050-2Z</b>	13 400	18 800	830	14 400	8 600	0,06
<b>ZKLFA1263-2RS</b>	16 900	24 700	1 090	9 200	3 800	0,16
<b>ZKLFA1263-2Z</b>	16 900	24 700	1 090	12 000	7 600	0,08
<b>ZKLFA1563-2RS</b>	17 900	28 000	1 240	8 200	3 500	0,2
<b>ZKLFA1563-2Z</b>	17 900	28 000	1 240	10 800	7 000	0,1

② Adjacent construction, bearing screw mounted on flat surface; ④ Only valid in assembled condition

1) The screws are not included in the scope of delivery. Tightening torque according to manufacturer's data.

2) Based on rotating inner ring.

3) The recommended INA precision locknuts are not included in the scope of delivery and must be ordered separately.

4) The required axial locknut force must be observed when using other locknuts.

5) Only valid in conjunction with INA precision locknuts. Note the guidelines on locating/locating bearing arrangements, see page 54.

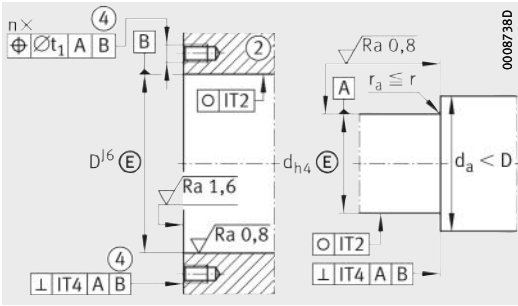

Design of housing and shaft (threaded spindle)



					Mounting dimensions			Fixing screws <sup>1)</sup> DIN EN ISO 4762 10.9	
r <sub>1</sub> min.	B <sub>1</sub>	d <sub>2</sub>	J	A	d <sub>a</sub>		t <sub>1</sub>	Size	n
					min.	max.			
0,6	8	5,5	40	35	14	27	0,1	M5	4
0,6	8	5,5	40	35	14	27	0,1	M5	4
0,6	10	6,8	53	45	16	31	0,1	M6	4
0,6	10	6,8	53	45	16	31	0,1	M6	4
0,6	10	6,8	53	45	20	34	0,1	M6	4
0,6	10	6,8	53	45	20	34	0,1	M6	4

Rigidity axial c <sub>aL</sub> N/μm	Tilting rigidity c <sub>kL</sub> Nm/ mrad	Mass moment of inertia <sup>2)</sup> M <sub>m</sub> kg · cm <sup>2</sup>	Axial runout <sup>2)</sup> μm	Recommended INA precision locknut <sup>3)</sup>			Required locknut force <sup>4)</sup> axial N
				For radial locking	For axial locking	Tightening torque <sup>5)</sup> M <sub>A</sub> Nm	
325	25	0,029	2	<b>ZM10</b>	–	6	4 891
325	25	0,029	2	<b>ZM10</b>	–	6	4 891
375	50	0,068	2	<b>ZM12</b>	–	8	5 307
375	50	0,068	2	<b>ZM12</b>	–	8	5 307
400	65	0,102	2	<b>ZM15</b>	<b>AM15</b>	10	5 484
400	65	0,102	2	<b>ZM15</b>	<b>AM15</b>	10	5 484

# Triple row axial angular contact ball bearings with flange

For screw mounting

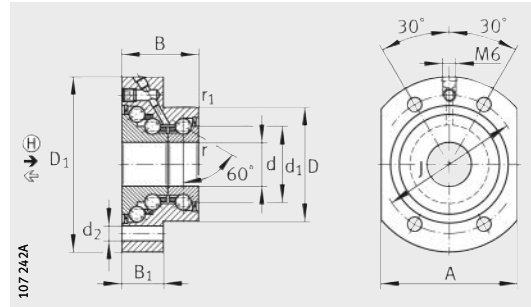

DKLFA...-2RS ( $d \leq 20 \text{ mm}$ )

### Attention!

The bearings require continuous load in the main load direction  $\oplus$ .

Dimension table - Dimensions in mm

Designation	Mass m ≈ kg	Dimensions											Mounting dimensions	
		d	D	B	d <sub>1</sub>	D <sub>1</sub>	r	r <sub>1</sub>	B <sub>1</sub>	d <sub>2</sub>	J	A	d <sub>a</sub>	
		-0,010	-0,013	-0,25			min.	min.					min.	max.
<b>DKLFA1575-2RS</b>	0,53	<b>15</b>	45	32	28	75	0,3	0,6	18	6,8	58	55	20	35
<b>DKLFA2080-2RS</b>	0,7	<b>20</b>	52	35	34,5	80	0,3	0,6	19	6,8	63	62	25	43
<b>DKLFA2590-2RS</b>	0,9	<b>25</b>	57	38	40,5	90	0,3	0,6	22	8,8	75	70	32	48
<b>DKLFA30100-2RS</b>	1	<b>30</b>	62	38	45,5	100	0,3	0,6	22	8,8	80	72	40	53
<b>DKLFA30110-2RS<sup>3)</sup></b>	2,5	<b>30</b>	75	56	51	110	0,3	0,6	35	8,8	95	85	47	64
<b>DKLFA40115-2RS</b>	1,5	<b>40</b>	72	42	58	115	0,3	0,6	23	8,8	94	90	50	67
<b>DKLFA40140-2RS<sup>3)</sup></b>	4,2	<b>40</b>	90	60	65	140	0,3	0,6	35	11	118	110	56	80

④ Only valid in assembled condition; ⑤ Adjacent construction, bearing screw mounted on flat surface;

⑥ Adjacent construction, bearing centred in adjacent construction

1) The screws are not included in the scope of delivery. Tightening torque according to manufacturer's data.

2) Based on rotating inner ring.

3) Heavy series.

4) The recommended INA precision locknuts are not included in the scope of delivery and must be ordered separately.

5) The required axial locknut force must be observed when using other locknuts.

6) Only valid in conjunction with INA precision locknuts in locating/non-locating bearing arrangements and for ① in locating/locating bearing arrangements. Note the guidelines on locating/locating bearing arrangements, see page 54.

### INA precision locknuts (accessories)

Triple row angular contact ball bearing	Recommended INA precision locknut <sup>4)</sup>				Required locknut force <sup>5)</sup> axial ① N
	For radial locking		For axial locking	Tightening torque <sup>6)</sup> ① M <sub>A</sub> Nm	
	①, ②	③	①, ②		
<b>DKLFA1575-2RS</b>	<b>ZMA15/33</b>	<b>ZM17</b>	<b>AM15</b>	10	6 270
<b>DKLFA2080-2RS</b>	<b>ZMA20/38</b>	<b>ZM25</b>	<b>AM20</b>	18	8 580
<b>DKLFA2590-2RS</b>	<b>ZMA25/45</b>	<b>ZM30</b>	<b>AM25</b>	25	9 670
<b>DKLFA30100-2RS</b>	<b>ZMA30/52</b>	<b>ZM35</b>	<b>AM30</b>	32	10 350
<b>DKLFA30110-2RS</b>	–	<b>ZM35</b>	<b>AM30/65</b>	65	20 500
<b>DKLFA40115-2RS</b>	<b>ZMA40/62</b>	<b>ZM45</b>	<b>AM40</b>	55	13 420
<b>DKLFA40140-2RS</b>	–	<b>ZM45</b>	<b>AM40/85</b>	110	26 600

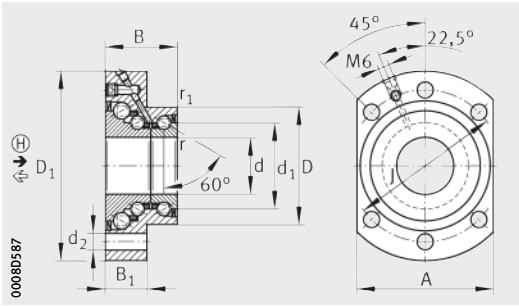

DKLFA..-2RS ( $d \geq 25 \text{ mm}$ )

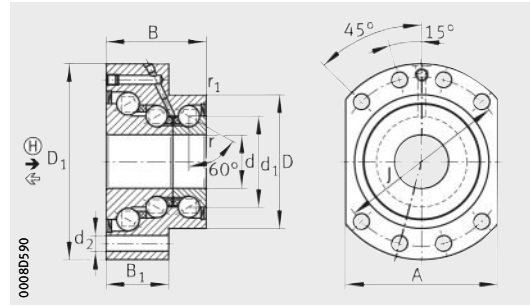

DKLFA..-2RS  
Heavy series

Fixing screws <sup>1)</sup> DIN EN ISO 4762		Basic load ratings				Fatigue limit load	Limiting speeds		Bearing fric- tional torque	Rigidity		Tilt- ing rigid- ity	Mass mo- ment of inertia <sup>2)</sup>	Axial run- out <sup>2)</sup>
		axial ←		axial →						axial ←	axial →			
		dyn. C <sub>a</sub>	stat. C <sub>0a</sub>	dyn. C <sub>a</sub>	stat. C <sub>0a</sub>					C <sub>aL</sub>	C <sub>aR</sub>			
10.9														
Size	n	N	N	N	N	N	n <sub>G</sub> grease min <sup>-1</sup>	n <sub>ø</sub> min <sup>-1</sup>	M <sub>RL</sub> Nm	C <sub>aL</sub> N/μm	C <sub>aR</sub> N/μm	C <sub>kL</sub> Nm/ mrad	M <sub>m</sub> kg · cm <sup>2</sup>	μm
M6	4	17 900	28 000	37 000	83 000	2 480	5 700	2 600	0,35	500	950	140	0,278	5
M6	4	26 000	47 000	44 500	110 000	2 850	5 000	2 200	0,45	750	1 100	260	0,553	5
M8	6	27 500	55 000	52 000	144 000	4 000	4 400	2 000	0,6	850	1 200	370	1,12	5
M8	6	29 000	64 000	55 000	165 000	4 550	4 000	1 800	0,75	900	1 400	500	1,7	5
M8	8	59 000	108 000	106 000	257 000	6 700	3 500	1 600	1,5	1 300	1 600	650	3,23	5
M8	6	43 000	101 000	73 000	227 000	5 700	3 200	1 500	1	1 100	1 700	1 000	4,23	5
M10	8	72 000	149 000	126 000	363 000	9 600	2 900	1 200	2,5	1 800	2 000	1 370	9,32	5

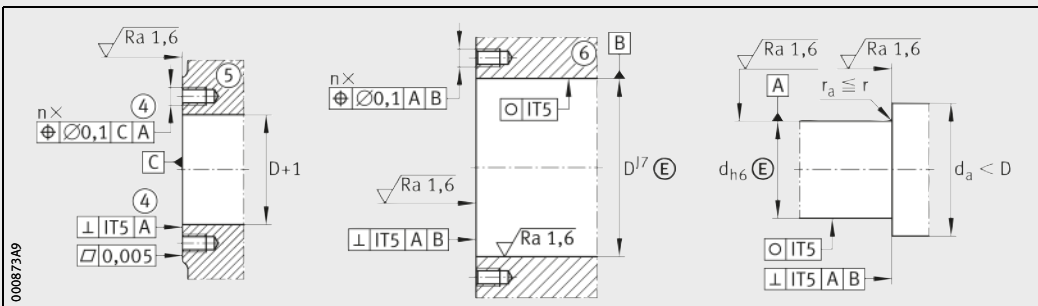

Design of housing and shaft (threaded spindle)

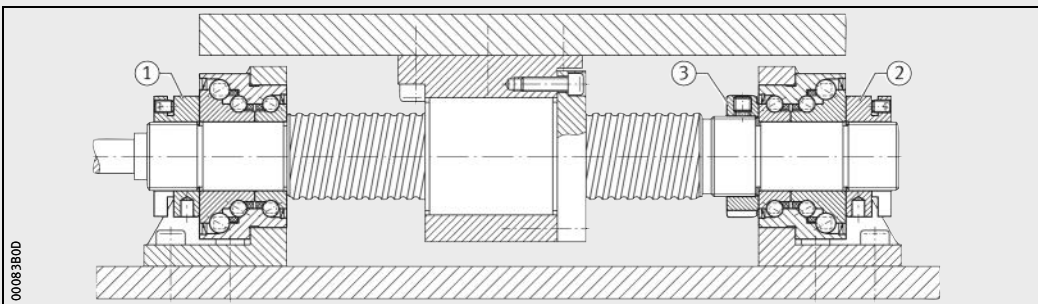

Ball screw drive spindle with locating bearing arrangement on both sides  
Numbers in circles: see table INA precision locknuts (accessories), see page 98



## Needle roller/axial cylindrical roller bearings

For screw mounting

Not for screw mounting

# Needle roller/axial cylindrical roller bearings

		Page
<b>Product overview</b>	Needle roller/axial cylindrical roller bearings .....	102
<b>Features</b>	Radial and axial load carrying capacity.....	103
	Preload and internal clearance.....	103
	Bearings for screw mounting.....	103
	Bearings not for screw mounting .....	104
	Operating temperature .....	104
	Suffixes .....	104
<b>Design and safety guidelines</b>	Basic rating life .....	105
	Static load safety factor .....	105
	Resultant and equivalent bearing load .....	106
	Design of adjacent construction.....	108
	Speeds.....	108
	Friction.....	109
	Lubrication .....	109
	Mounting guidelines.....	111
<b>Accuracy</b>	.....	112
<b>Dimension tables</b>	Needle roller/axial cylindrical roller bearings, light series, for screw mounting .....	114
	Needle roller/axial cylindrical roller bearings, heavy series, for screw mounting .....	118
	Needle roller/axial cylindrical roller bearings, light series, not for screw mounting .....	124
	Needle roller/axial cylindrical roller bearings, heavy series, not for screw mounting .....	128

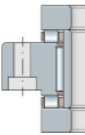

# Product overview Needle roller/axial cylindrical roller bearings

## For screw mounting

ZARF

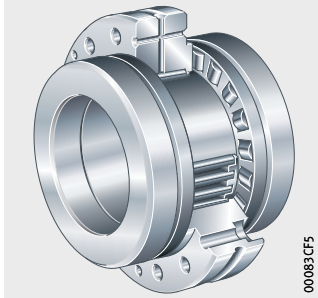

With stepped shaft locating washer extended on one side

ZARF..-L

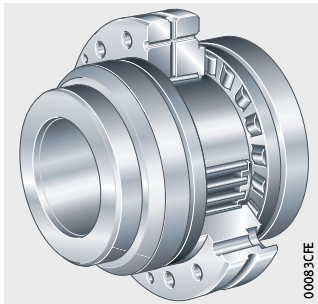

## Not for screw mounting

ZARN

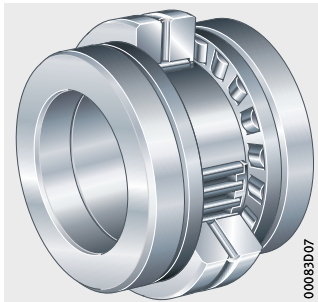

With stepped shaft locating washer extended on one side

ZARN..-L

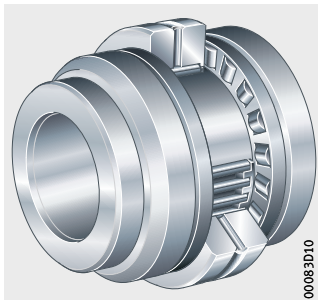



# Needle roller/axial cylindrical roller bearings

**Features** Needle roller/axial cylindrical roller bearings comprise an outer ring with radial and axial raceways, shaft locating washers, an inner ring, a radial needle roller and cage assembly and axial cylindrical roller and cage assemblies. The bearings are available in versions for screw mounting and not for screw mounting.

**Radial and axial load carrying capacity** In addition to radial forces, the bearings can also support axial forces from both directions and tilting moments.

**Preload and internal clearance** The outer ring, inner ring and axial cages are matched to each other such that the bearing is axially clearance-free after preloading by means of an INA precision locknut. The radial internal clearance conforms to Group 2 in accordance with ISO 5753-1 (DIN 620-4).

**Bearings for screw mounting** Needle roller/axial cylindrical roller bearings ZARF(L) have holes in the outer ring. These are used for screw mounting directly on the adjacent construction or in a radial locating bore, *Figure 1*.

Due to screw mounting of the outer ring, the cover that would otherwise be required and the matching work can therefore be dispensed with. The bearings are preloaded against the shaft shoulder by means of a locknut AM or ZM(A).

**With seal carrier assembly** In the interests of a simpler design, a seal carrier assembly DRS, *Figure 1* is recommended. The seal carrier assembly is centred on the outer ring and seals the bearing against outside influences.

## ZARF.-L

- ① Seal carrier assembly DRS
- ② Locknut AM
- ③ Stepped shaft locating washer extended on one side
- ④ Rotary shaft seal DIN 3760-...NBR

*Figure 1*  
Stepped shaft locating washer with sealing ring

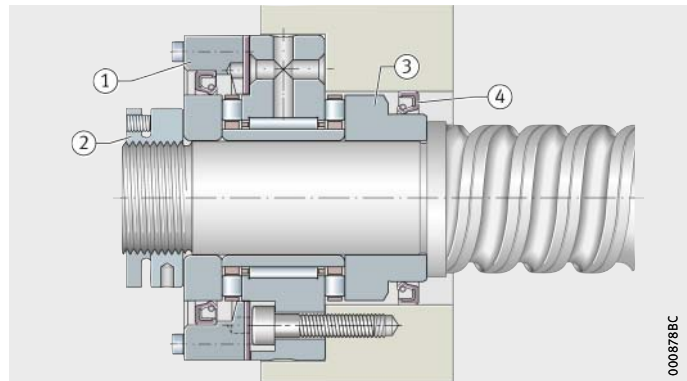

**With stepped shaft locating washer** ZARF.-L has a stepped shaft locating washer extended on one side, *Figure 1*. These series are used in preference where the shaft locating washers are not adequately supported axially by the shaft shoulder or the bearing unit cannot be sealed on the outside surface of the normal shaft locating washer due to space conditions in the adjacent construction.

**Heavy series** ZARF(L) is also available in a heavy series. This series has a larger cross-section for the same shaft diameter and therefore higher basic load ratings.

# Needle roller/axial cylindrical roller bearings

## Bearings not for screw mounting

Bearings ZARN(L) are mounted in a housing bore and the outer ring is located using a cover, *Figure 2*. They are preloaded against the shaft shoulder by means of a locknut AM or ZM(A).

**ZARN**

① Cover

*Figure 2*  
Bearing outer ring located using cover

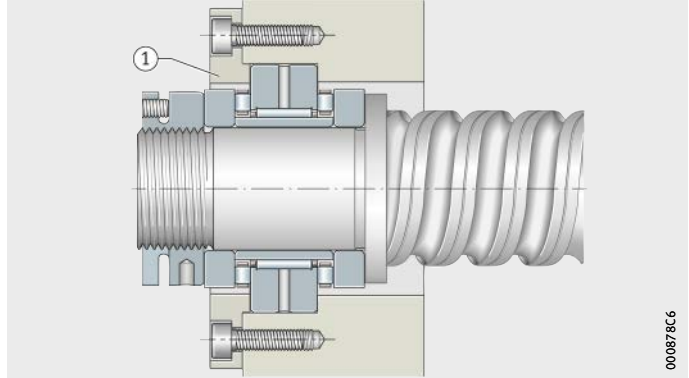

## With stepped shaft locating washer

ZARF..-L has a stepped shaft locating washer extended on one side, *Figure 3*. This series is used in preference where the shaft locating washer is not adequately supported axially by the shaft shoulder or the bearing unit cannot be sealed on the outside surface of the normal shaft locating washer due to space conditions in the adjacent construction.

**ZARN..-L**

- ① Stepped shaft locating washer extended on one side
- ② Rotary shaft seal DIN 3760

*Figure 3*  
Stepped shaft locating washer with sealing ring

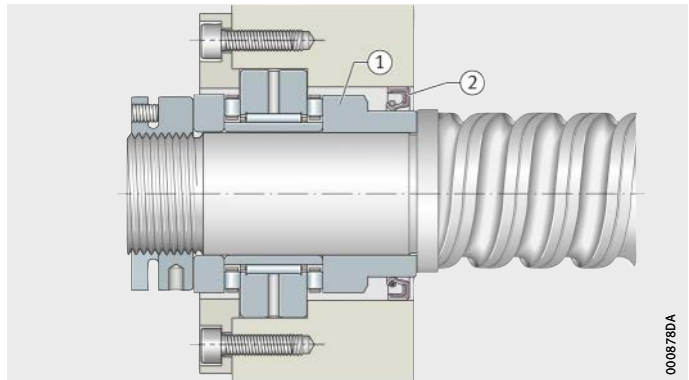

## Heavy series

ZARN(L) is also available in a heavy series. This series has a larger cross-section for the same shaft diameter and therefore higher basic load ratings.

## Operating temperature

The bearings are suitable for temperatures from  $-30\text{ °C}$  to  $+120\text{ °C}$ .

## Suffixes

Suffixes for available designs, see table.

## Available designs

Suffix	Description	Design
L	Stepped shaft locating washer extended on one side	Standard
TV	Axial bearing cages made from polyamide PA66	

## Design and safety guidelines

### Basic rating life

The decisive factors in determining the bearing size are the basic rating life, the static load safety factor and the axial limiting load.

The rating life  $L_{10}$  or  $L_{10h}$  is calculated as follows:

$$L_{10} = \left(\frac{C}{P}\right)^p$$

$$L_{10h} = \frac{16\,666}{n} \cdot \left(\frac{C}{P}\right)^p$$

$L_{10}$   $10^6$  revolutions  
Basic rating life in millions of revolutions

$L_{10h}$  h  
Basic rating life in operating hours

$C_r, C_a$  N  
Basic dynamic radial or axial load rating, see dimension tables

$C_r$  is valid for a contact angle  $\alpha \leq 45^\circ$ ,

$C_a$  is valid for a contact angle  $\alpha > 45^\circ$

P N  
Equivalent dynamic bearing load

p –  
Life exponent  $p = 10/3$

n  $\text{min}^{-1}$   
Operating speed.

### Static load safety factor

The static load safety factor  $S_0$  indicates the security against impermissible permanent deformations in the bearing, see page 29:

$$S_0 = \frac{C_0}{P_0}$$

$S_0$  –  
Static load safety factor

$C_{0r}, C_{0a}$  N  
Basic dynamic radial or axial load rating, see dimension tables

$C_{0r}$  is valid for a contact angle  $\alpha \leq 45^\circ$ ,

$C_{0a}$  is valid for a contact angle  $\alpha > 45^\circ$

$P_0$  N  
Maximum static load of bearing.



In machine tools,  $S_0$  should be  $\geq 4$ .

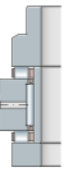
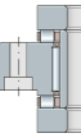

# Needle roller/axial cylindrical roller bearings

## Resultant and equivalent bearing load

The resultant axial bearing load  $F_{a\ res}$  is determined from the axial operating load  $F_{aB}$  and taking account of the axial preload, *Figure 4*, page 107, to *Figure 6*, page 107.

Under pure axial load,  $P = F_{a\ res}$ . If additional radial operating loads are present, these must be calculated separately using the basic radial load ratings. The limiting loads up to which the axial load can be supported without clearance are shown, *Figure 4*, page 107, to *Figure 6*, page 107.

The needle roller/axial cylindrical roller bearings ZARN and ZARF can be subjected to higher axial preload in order to increase the lift-off load. In this case, it must be taken into consideration that this will cause an increase in friction and temperature as well as a reduction in the basic rating life. The increase in preload is achieved by using a higher tightening torque for the locknut.



In the case of roller bearings, the lift-off load must not be exceeded during highly dynamic acceleration events. As a result, higher wear will occur under rapid acceleration.

For extreme moment loads and statically overdefined systems (locating/locating bearing arrangements), please contact us. The calculation program BEARINX can give a precise design in this case.

## Load varying in steps

In this case,  $P$  and  $n$  are calculated as follows:

$$P = p \sqrt{\frac{q_1 \cdot n_1 \cdot P_1^p + \dots + q_z \cdot n_z \cdot P_z^p}{q_1 \cdot n_1 + \dots + q_z \cdot n_z}}$$

$$n = \frac{q_1 \cdot n_1 + \dots + q_z \cdot n_z}{100}$$

$P$	N
Equivalent dynamic bearing load	
$p$	-
Life exponent $p = 10/3$	
$q$	%
Time proportion	
$n$	$\text{min}^{-1}$
Operating speed.	

$F_{aB}$  = operating load  
 $F_{a\text{ res}}$  = resultant bearing load  
 $\circ$  = limiting load

**Figure 4**  
 Resultant bearing load  
 for ZARN, ZARF, light series

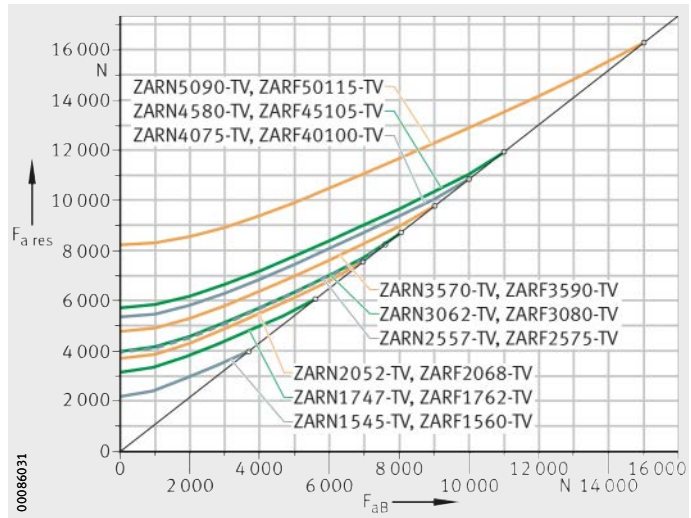

$F_{aB}$  = operating load  
 $F_{a\text{ res}}$  = resultant bearing load  
 $\circ$  = limiting load

**Figure 5**  
 Resultant bearing load  
 for ZARN, ZARF, heavy series  
 up to  $d = 50\text{ mm}$

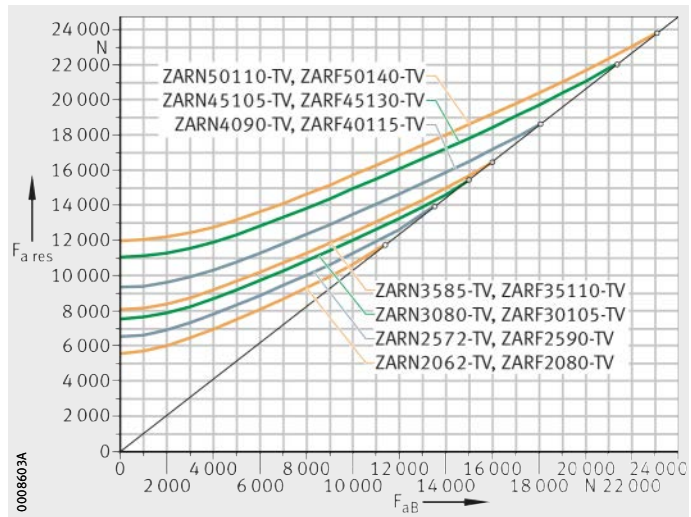

$F_{aB}$  = operating load  
 $F_{a\text{ res}}$  = resultant bearing load  
 $\circ$  = limiting load

**Figure 6**  
 Resultant bearing load  
 for ZARN, ZARF, heavy series  
 starting from  $d = 55\text{ mm}$

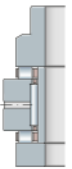
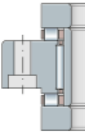
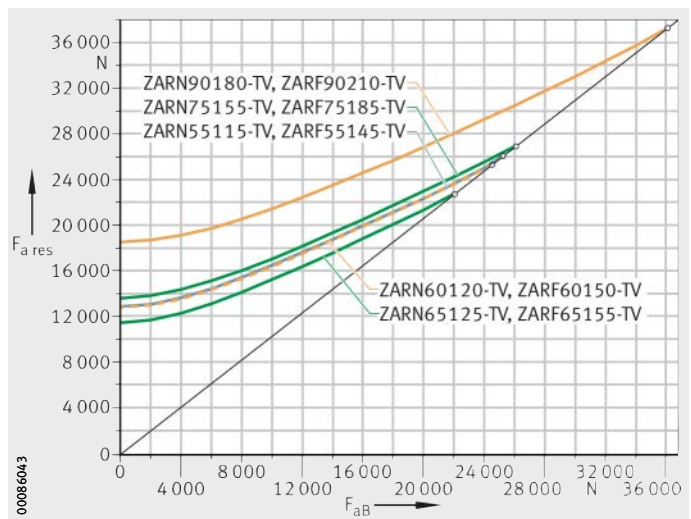

# Needle roller/axial cylindrical roller bearings

## Design of adjacent construction

The adjacent construction (the shaft and housing) must be designed in accordance with the data in the dimension tables.

The abutment diameters for the shaft and housing shoulders  $d_a$  and  $D_a$  must be in accordance with the dimension tables.



The permissible contact pressure for the adjacent construction must be observed.

The design of the adjacent construction must include the provision of lubricant feeds to page 110.

## Sealing of the bearing position

The bearings are sealed, *Figure 1*, page 103:

- sealing in the direction of the threaded spindle by a rotary shaft seal on the outside surface machined free from spiral marks of the stepped shaft locating washer (ZARN..-L, ZARF..-L)
- sealing in the direction of the drive by the seal carrier assembly DRS.

## Speeds

The limiting speeds  $n_G$  given in the dimension tables are based on the following conditions:

- bearing preloaded, no external operating load
- operating duration 25%
- maximum equilibrium temperature +50 °C.



The limiting speeds  $n_G$  are valid for oil lubrication with adequate cooling.

**Friction** In most applications, preloading of bearings by means of the locknut tightening torque gives sufficiently accurate setting values. The reference here is the tightening torque  $M_A$  in accordance with the dimension tables in conjunction with an INA precision locknut. The frictional torque  $M_{RL}$  given in the dimension tables is a guide value. It is based on lightly oiled bearings, measured at a speed of  $n = 5 \text{ min}^{-1}$ . For dimensioning of the drive, the starting frictional torque and the frictional torque at high speeds in each case of  $2 \cdot M_{RL}$  to  $3 \cdot M_{RL}$  must be taken into consideration.

**Frictional torque and bearing preload** For applications in which the frictional torque is decisive for example temperature development, frictional torque compensation between different bearing positions, etc.), it is recommended that the bearing preload should be set in accordance with the bearing frictional torque  $M_{RL}$ .

**Frictional energy** The frictional energy  $N_R$  of the bearings can be calculated as follows:

$$N_R = \frac{M_{RL} \cdot n}{9,55}$$

$N_R$	W
Frictional energy	
$M_{RL}$	Nm
Bearing frictional torque	
$n$	$\text{min}^{-1}$
Operating speed.	

In any analysis of the thermal balance, the various operating speeds  $n_i$  must be taken into consideration with their time durations  $q_i$ .

**Lubrication** Needle roller/axial cylindrical roller bearings can be relubricated via the outer ring. They are supplied with oil-based or dry preservative and should preferably be lubricated with oil.

Oils CLP to DIN 51517 and HLP to DIN 51524 of viscosity classes ISO VG 32 to ISO VG 100 have proved effective.

**Relubrication for grease lubrication** Relubrication should be carried out with the bearing rotating and still warm from operation in order to achieve good replacement and distribution of grease.

The relubrication interval and quantity can only be determined under operating conditions since it is not possible to calculate all the influences in advance. For information on relubrication, see TPI 100, Bearings for Screw Drives, Mounting and Maintenance Manual.



Where a vertical axis of rotation is used in conjunction with automatic lubrication systems, the lubrication impulse should be selected such that the supply to the upper axial bearing is sufficient.

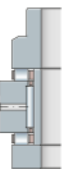
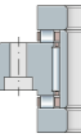

# Needle roller/axial cylindrical roller bearings

## Lubricant feed

In the selection of lubricant feeds for ZARF(L), the mounting position must be observed, *Figure 7* and *Figure 8*.



Before commissioning, it must be ensured that all raceways are adequately supplied with lubricant.

- ZARF..-L**
- ① Oil inlet
  - ② Oil outlet
  - ③ Rotary shaft seal
  - ④ Cover
  - ⑤ Seal carrier assembly

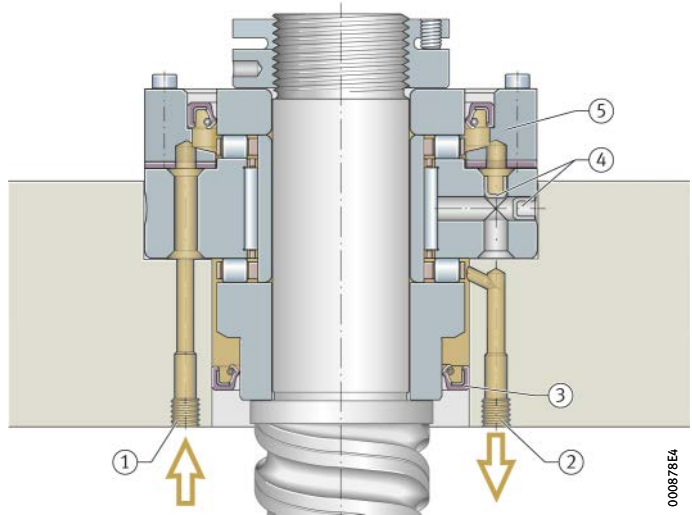

*Figure 7*  
Lubricant feed  
for vertical mounting position

- ZARF..-L**
- ① Oil inlet
  - ② Oil outlet
  - ③ Rotary shaft seal
  - ④ Cover
  - ⑤ Seal carrier assembly

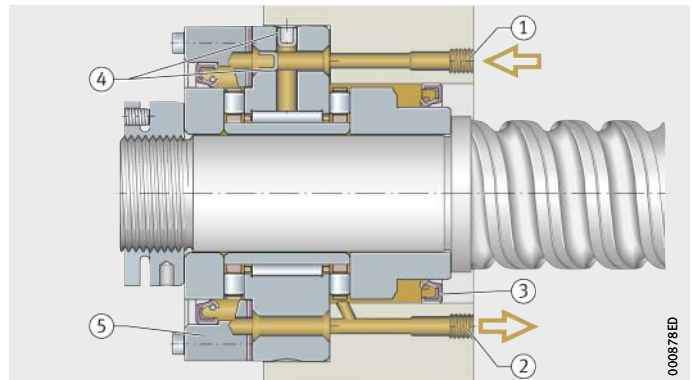

*Figure 8*  
Lubricant feed  
for horizontal mounting position



## Mounting guidelines

Needle roller/axial cylindrical roller bearings ZARN and ZARF are not self-retaining. The individual bearing components are matched to each other. The individual parts of different bearings must not be interchanged during mounting.

The characteristics of the bearings are only valid when used in combination with INA precision locknuts and the associated tightening torques given in the dimension tables.



During mounting of bearings, mounting forces should be applied only to the bearing ring to be mounted. Mounting forces must never be directed through the rolling elements.

Bearings should only be mounted and dismounted in accordance with the Mounting and Maintenance Manual.

## Further information

- TPI 100, Bearings for Screw Drives, Mounting and Maintenance Manual
- Download and ordering: <http://medien.schaeffler.de>.

## Setting the axial preload

Since direct force measurement of this value during mounting operation is not cost-effective, the axial preload is set indirectly and using one of the following methods:

- by means of the tightening torque  $M_A$  of the precision locknut. The frictional torque may deviate from the value given in the dimension table
- by means of the bearing frictional torque  $M_{RL}$ .



In the axial component of needle roller/axial cylindrical roller bearings ZARF(L), the preload is a decisive factor for correct functioning. It must therefore be set with sufficient accuracy.

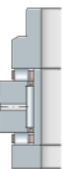
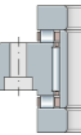

# Needle roller/axial cylindrical roller bearings

- Preloading by locknut** Needle roller/axial cylindrical roller bearings must be axially preloaded during mounting by means of a precision locknut. If the bearing unit is preloaded via the bearing inner rings using the recommended precision locknut, the tightening torques given in the dimension tables must be observed or the preload must be set using the bearing frictional torque given in the dimension tables. The tightening torques given for the individual bearing sizes are only valid for the precision locknuts listed.
- For locating/non-locating bearing arrangements and bearing arrangements for rotating ball screw drive nuts, the tightening torques can be taken directly from the dimension tables.
- In the case of needle roller/axial cylindrical roller bearings ZARN and ZARF, this tightening torque can be increased if a higher axial limiting load is required. The increase must take account of the increasing bearing friction, increase in bearing temperature and the decreased basic rating life. For information on limit values, please consult Schaeffler.
- For locating/locating bearing arrangements, the locknut tightening torques must be calculated by means of BEARINX. In this case, please contact us or use BEARINX-online.
- In order to counteract settling, it is recommended that the locknut should initially be tightened to twice the tightening torque  $M_A$  and then relieved of load again. It should only then be tightened again to the stated tightening torque  $M_A$ . Finally, the precision locknut should be secured against rotation by the torque-controlled tightening of the grub screws.
- Fixing screws** For location of the outer ring, screws of grade 10.9 should be used. Screws should be fully tightened with torque control in accordance with the manufacturer's instructions and in a crosswise sequence.
- If the bearing outer ring is supported by an additional housing cover, it must be ensured that the fixing screws are sufficiently well dimensioned.
- Accuracy** The accuracy of dimensions must be configured as follows:
- axial: tolerance class 4 to ISO 199
  - radial: tolerance class 6 to ISO 492.

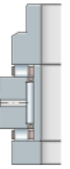
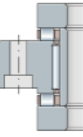

# Needle roller/axial cylindrical roller bearings

Light series  
For screw mounting

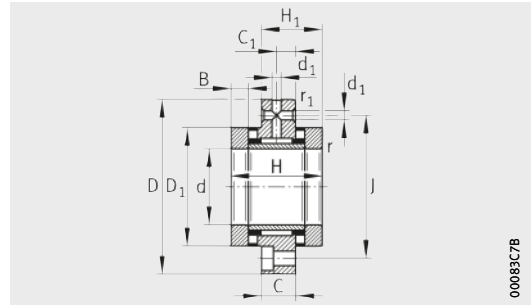

ZARF

00083C7B

**Dimension table** - Dimensions in mm

Designation	Mass m ≈ kg	Dimensions																	
		d	D	H	H <sub>1</sub>	H <sub>2</sub>	H <sub>3</sub>	C	C <sub>1</sub>	D <sub>1</sub>	D <sub>2</sub>	D <sub>3</sub>	B	B <sub>1</sub>	B <sub>2</sub>	r	r <sub>1</sub>	d <sub>1</sub>	J
ZARF1560-TV	0,42	15	60	40	26	-	-	14	8	35	-	-	7,5	-	-	0,3	0,6	3,2	46
ZARF1560-L-TV	0,45	15	60	-	-	53	39	14	8	35	24	34	7,5	20,5	11	0,3	0,6	3,2	46
ZARF1762-TV	0,49	17	62	43	27,5	-	-	14	8	38	-	-	9	-	-	0,3	0,6	3,2	48
ZARF1762-L-TV	0,52	17	62	-	-	57	41,5	14	8	38	28	38	9	23	11	0,3	0,6	3,2	48
ZARF2068-TV	0,56	20	68	46	29	-	-	14	8	42	-	-	10	-	-	0,3	0,6	3,2	53
ZARF2068-L-TV	0,61	20	68	-	-	60	43	14	8	42	30	40	10	24	12	0,3	0,6	3,2	53
ZARF2575-TV	0,78	25	75	50	33	-	-	18	10	47	-	-	10	-	-	0,3	0,6	3,2	58
ZARF2575-L-TV	0,84	25	75	-	-	65	48	18	10	47	36	45	10	25	12	0,3	0,6	3,2	58
ZARF3080-TV	0,85	30	80	50	33	-	-	18	10	52	-	-	10	-	-	0,3	0,6	3,2	63
ZARF3080-L-TV	0,9	30	80	-	-	65	48	18	10	52	40	50	10	25	13	0,3	0,6	3,2	63

① Mounting dimension for seal carrier assembly DRS, see page 146; ③ Adjacent construction, bearing screw mounted in bore;  
④ Only valid in assembled condition

- 1) If rotary shaft seals are used, the outside diameter of the sealing ring must be taken into consideration.
- 2) Based on rotating inner ring.
- 3) The recommended INA precision locknuts are not included in the scope of delivery and must be ordered separately.
- 4) The required axial locknut force must be observed when using other locknuts.
- 5) The screws are not included in the scope of delivery. Tightening torque according to manufacturer's data.
- 6) Only valid in conjunction with INA precision locknuts. Note the guidelines on locating/locating bearing arrangements, see page 54.

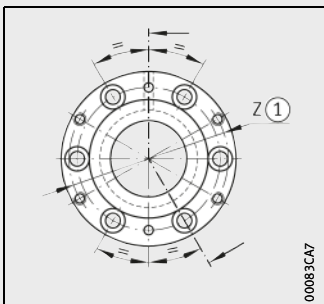

Hole pattern  
ZARF1560, ZARF1762

00083CA7

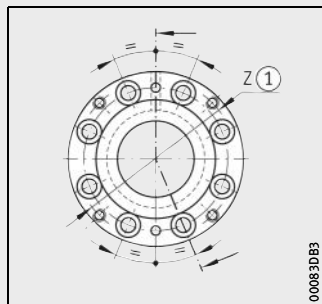

Hole pattern  
ZARF2068, ZARF2575

00083DB3

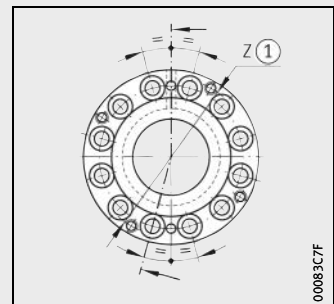

Hole pattern  
ZARF3080

00083C7F

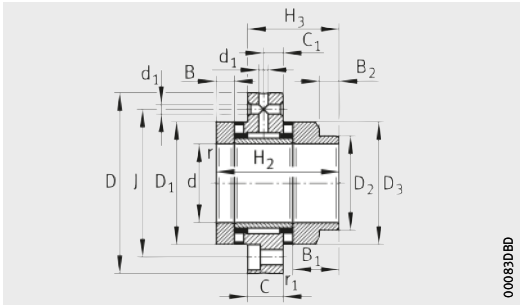

ZARF.-L

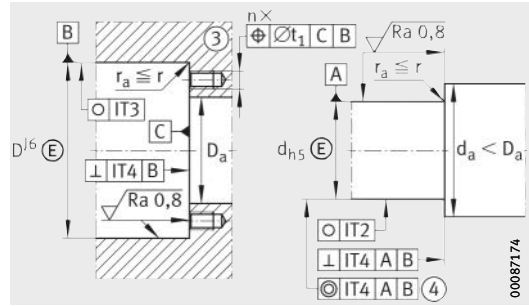

Design of housing and shaft (threaded spindle)

Mounting dimensions <sup>1)</sup>			Basic load ratings				Fatigue limit load		Limiting speeds		Bearing frictional torque	Rigidity axial	Tilting rigidity
			axial		radial		axial	radial	n <sub>G</sub> oil min <sup>-1</sup>	n <sub>G</sub> grease min <sup>-1</sup>			
D <sub>a</sub> max.	d <sub>a</sub> min.	t <sub>1</sub>	dyn. C <sub>a</sub> N	stat. C <sub>0a</sub> N	dyn. C <sub>r</sub> N	stat. C <sub>0r</sub> N	C <sub>ua</sub> N	C <sub>ur</sub> N			M <sub>RL</sub> Nm	c <sub>aL</sub> N/μm	c <sub>kL</sub> Nm/mrad
36	28	0,1	24 900	53 000	13 000	17 500	7 300	2 600	8 500	2 200	0,35	1 400	110
36	22	0,1	24 900	53 000	13 000	17 500	7 300	2 600	8 500	2 200	0,35	1 400	110
39	28	0,1	26 000	57 000	14 000	19 900	7 900	2 950	7 800	2 100	0,4	1 600	160
39	26	0,1	26 000	57 000	14 000	19 900	7 900	2 950	7 800	2 100	0,4	1 600	160
43	33	0,1	33 500	76 000	14 900	22 400	6 300	3 350	7 000	2 000	0,5	1 800	230
43	28	0,1	33 500	76 000	14 900	22 400	6 300	3 350	7 000	2 000	0,5	1 800	230
48	39	0,1	35 500	86 000	22 600	36 000	7 100	5 100	6 000	1 900	0,55	1 900	350
48	34	0,1	35 500	86 000	22 600	36 000	7 100	5 100	6 000	1 900	0,55	1 900	350
53	44	0,1	39 000	101 000	24 300	41 500	8 400	5 900	5 500	1 800	0,65	2 200	520
53	38	0,1	39 000	101 000	24 300	41 500	8 400	5 900	5 500	1 800	0,65	2 200	520

Dimension table (continued) · Dimensions in mm

Designation	Mass moment of inertia <sup>2)</sup> M <sub>m</sub> kg · cm <sup>2</sup>	Axial run-out <sup>2)</sup> μm	Recommended INA precision locknut <sup>3)</sup>			Required locknut force <sup>4)</sup> axial N	Rotary shaft seal to DIN 3760; to be ordered separately	Fixing screws <sup>5)</sup> DIN EN ISO 4762 10.9	
			For radial locking	For axial locking	Tightening torque <sup>6)</sup> M <sub>A</sub> Nm			Size	n
ZARF1560-TV	0,24	1	ZMA15/33	AM15	10	6 506	–	M6	6
ZARF1560-L-TV	0,274	1	ZMA15/33	AM15	10	6 506	24×35×7	M6	6
ZARF1762-TV	0,373	1	ZM17	AM17	12	7 078	–	M6	6
ZARF1762-L-TV	0,464	1	ZM17	AM17	12	7 078	28×40×7	M6	6
ZARF2068-TV	0,615	1	ZMA20/38	AM20	18	8 972	–	M6	8
ZARF2068-L-TV	0,683	1	ZMA20/38	AM20	18	8 972	30×42×7	M6	8
ZARF2575-TV	0,989	1	ZMA25/45	AM25	25	9 745	–	M6	8
ZARF2575-L-TV	1,15	1	ZMA25/45	AM25	25	9 745	36×47×7	M6	8
ZARF3080-TV	1,46	1	ZMA30/52	AM30	32	10 662	–	M6	12
ZARF3080-L-TV	1,7	1	ZMA30/52	AM30	32	10 662	40×52×7	M6	12

# Needle roller/axial cylindrical roller bearings

Light series  
For screw mounting

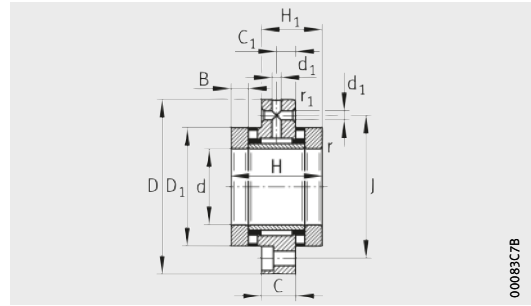

ZARF

00083C7B

**Dimension table** (continued) · Dimensions in mm

Designation	Mass m ≈ kg	Dimensions																	
		d	D	H	H <sub>1</sub>	H <sub>2</sub>	H <sub>3</sub>	C	C <sub>1</sub>	D <sub>1</sub>	D <sub>2</sub>	D <sub>3</sub>	B	B <sub>1</sub>	B <sub>2</sub>	r	r <sub>1</sub>	d <sub>1</sub>	J
ZARF3590-TV	1,12	35	90	54	35	-	-	18	10	60	-	-	11	-	-	0,3	0,6	3,2	73
ZARF3590-L-TV	1,25	35	90	-	-	70	51	18	10	60	45	58	11	27	13	0,3	0,6	3,2	73
ZARF40100-TV	1,35	40	100	54	35	-	-	18	10	65	-	-	11	-	-	0,3	0,6	3,2	80
ZARF40100-L-TV	1,45	40	100	-	-	70	51	18	10	65	50	63	11	27	14	0,3	0,6	3,2	80
ZARF45105-TV	1,7	45	105	60	40	-	-	22,5	12,5	70	-	-	11,5	-	-	0,3	0,6	6	85
ZARF45105-L-TV	1,85	45	105	-	-	75	55	22,5	12,5	70	56	68	11,5	26,5	13	0,3	0,6	6	85
ZARF50115-TV	2,1	50	115	60	40	-	-	22,5	12,5	78	-	-	11,5	-	-	0,3	0,6	6	94
ZARF50115-L-TV	2,45	50	115	-	-	78	58	22,5	12,5	78	60	78	11,5	29,5	14	0,3	0,6	6	94

- ① Mounting dimension for seal carrier assembly DRS, see page 146; ③ Adjacent construction, bearing screw mounted in bore;
- ④ Only valid in assembled condition

- 1) If rotary shaft seals are used, the outside diameter of the sealing ring must be taken into consideration.
- 2) Based on rotating inner ring.
- 3) The recommended INA precision locknuts are not included in the scope of delivery and must be ordered separately.
- 4) The required axial locknut force must be observed when using other locknuts.
- 5) Tightening torque of fixing screws according to manufacturer's data.  
The screws are not included in the scope of delivery.
- 6) Only valid in conjunction with INA precision locknuts. Note the guidelines on locating/locating bearing arrangements, see page 54.

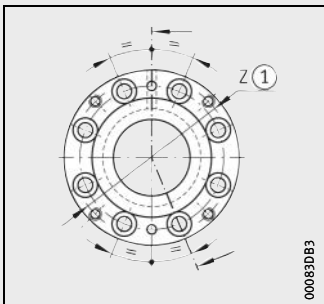

Hole pattern  
ZARF40100, ZARF45105

00083D83

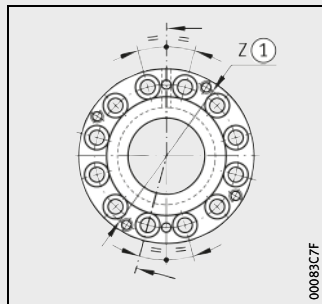

Hole pattern  
ZARF3590, ZARF50115

00083C7F

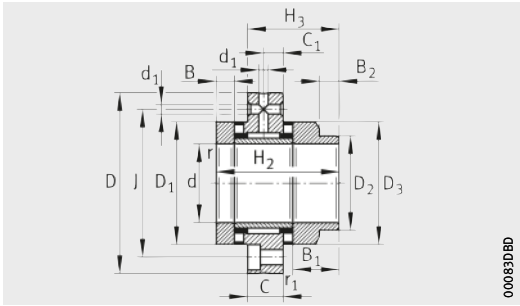

ZARF..L

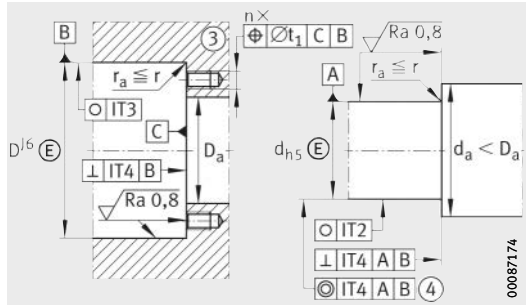

Design of housing and shaft (threaded spindle)

Mounting dimensions <sup>1)</sup>			Basic load ratings				Fatigue limit load		Limiting speeds		Bearing frictional torque	Rigidity axial	Tilting rigidity
			axial		radial		axial	radial	n <sub>G</sub> oil	n <sub>G</sub> grease			
D <sub>a</sub>	d <sub>a</sub>	t <sub>1</sub>	dyn. C <sub>a</sub>	stat. C <sub>0a</sub>	dyn. C <sub>r</sub>	stat. C <sub>0r</sub>	C <sub>ua</sub>	C <sub>ur</sub>	min <sup>-1</sup>	min <sup>-1</sup>	M <sub>RL</sub>	c <sub>aL</sub>	c <sub>kL</sub>
max.	min.		N	N	N	N	N	N			Nm	N/μm	Nm/mrad
61	50	0,1	56 000	148 000	26 000	47 000	12 800	6 700	4 800	1 700	0,9	2 600	740
61	43	0,1	56 000	148 000	26 000	47 000	12 800	6 700	4 800	1 700	0,9	2 600	740
66	55	0,2	59 000	163 000	27 500	53 000	14 100	7 500	4 400	1 600	1	2 800	1 030
66	48	0,2	59 000	163 000	27 500	53 000	14 100	7 500	4 400	1 600	1	2 800	1 030
71	60	0,2	61 000	177 000	38 000	74 000	15 400	10 200	4 000	1 500	1,2	3 000	1 340
71	54	0,2	61 000	177 000	38 000	74 000	15 400	10 200	4 000	1 500	1,2	3 000	1 340
79	67	0,2	90 000	300 000	40 000	82 000	27 500	11 300	3 600	1 200	2,2	4 800	2 470
79	58	0,2	90 000	300 000	40 000	82 000	27 500	11 300	3 600	1 200	2,2	4 800	2 470

Dimension table (continued) · Dimensions in mm

Designation	Mass moment of inertia <sup>2)</sup>	Axial run-out <sup>2)</sup>	Recommended INA precision locknut <sup>3)</sup>			Required locknut force <sup>4)</sup>	Rotary shaft seal to DIN 3760; to be ordered separately	Fixing screws <sup>5)</sup>	
			For radial locking	For axial locking	Tightening torque <sup>6)</sup>			Size	n
	M <sub>m</sub> kg · cm <sup>2</sup>	μm			M <sub>A</sub> Nm	N			
ZARF3590-TV	2,8	1	ZMA35/58	AM35/58	40	12 143	–	M6	12
ZARF3590-L-TV	3,21	1	ZMA35/58	AM35/58	40	12 143	45×60×8	M6	12
ZARF40100-TV	3,78	1	ZMA40/62	AM40	55	14 240	–	M8	8
ZARF40100-L-TV	4,35	1	ZMA40/62	AM40	55	14 240	50×65×8	M8	8
ZARF45105-TV	5,33	1	ZMA45/68	AM45	65	15 112	–	M8	8
ZARF45105-L-TV	6,03	1	ZMA45/68	AM45	65	15 112	56×70×8	M8	8
ZARF50115-TV	8,42	1	ZMA50/75	AM50	85	18 410	–	M8	12
ZARF50115-L-TV	10,46	1	ZMA50/75	AM50	85	18 410	60×80×8	M8	12

# Needle roller/axial cylindrical roller bearings

Heavy series  
For screw mounting

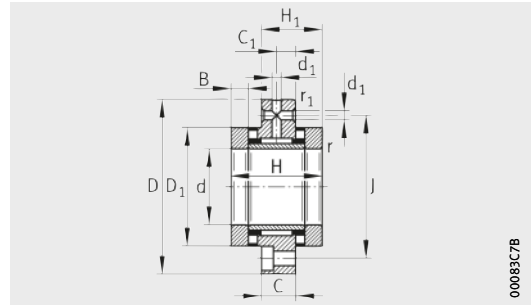

ZARF

00083C7B

**Dimension table** - Dimensions in mm

Designation	Mass m ≈ kg	Dimensions																	
		d	D	H	H <sub>1</sub>	H <sub>2</sub>	H <sub>3</sub>	C	C <sub>1</sub>	D <sub>1</sub>	D <sub>2</sub>	D <sub>3</sub>	B	B <sub>1</sub>	B <sub>2</sub>	r	r <sub>1</sub>	d <sub>1</sub>	J
ZARF2080-TV	1,1	20	80	60	38	-	-	18	10	52	-	-	12,5	-	-	0,3	0,6	3,2	63
ZARF2080-L-TV	1,22	20	80	-	-	75	53	18	10	52	40	50	12,5	27,5	13	0,3	0,6	3,2	63
ZARF2590-TV	1,6	25	90	60	38	-	-	18	10	62	-	-	12,5	-	-	0,3	0,6	3,2	73
ZARF2590-L-TV	1,75	25	90	-	-	75	53	18	10	62	48	60	12,5	27,5	13	0,3	0,6	3,2	73
ZARF30105-TV	1,95	30	105	66	41	-	-	18	10	68	-	-	14	-	-	0,3	0,6	3,2	85
ZARF30105-L-TV	2,15	30	105	-	-	82	57	18	10	68	52	66	14	30	13	0,3	0,6	3,2	85
ZARF35110-TV	1,6	35	110	66	41	-	-	18	10	73	-	-	14	-	-	0,3	0,6	3,2	88
ZARF35110-L-TV	1,85	35	110	-	-	82	57	18	10	73	60	73	14	30	13	0,3	0,6	3,2	88
ZARF40115-TV	2,7	40	115	75	47,5	-	-	22,5	12,5	78	-	-	16	-	-	0,3	0,6	6	94
ZARF40115-L-TV	3	40	115	-	-	93	65,5	22,5	12,5	78	60	78	16	34	14	0,3	0,6	6	94
ZARF45130-TV	3,9	45	130	82	51	-	-	22,5	12,5	90	-	-	17,5	-	-	0,3	0,6	6	105
ZARF45130-L-TV	4,3	45	130	-	-	103	72	22,5	12,5	90	70	88	17,5	38,5	18	0,3	0,6	6	105

- ① Mounting dimension for seal carrier assembly DRS, see page 146; ③ Adjacent construction, bearing screw mounted in bore;
- ④ Only valid in assembled condition.

- 1) If rotary shaft seals are used, the outside diameter of the sealing ring must be taken into consideration.
- 2) Based on rotating inner ring.
- 3) The recommended INA precision locknuts are not included in the scope of delivery and must be ordered separately.
- 4) The required axial locknut force must be observed when using other locknuts.
- 5) Tightening torque of fixing screws according to manufacturer's data.  
Screws are not included in the delivery.
- 6) Only valid in conjunction with INA precision locknuts. Note the guidelines on locating/locating bearing arrangements, see page 54.

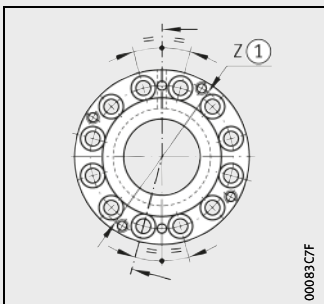

Hole pattern



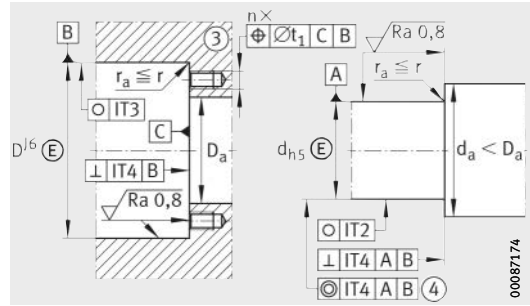
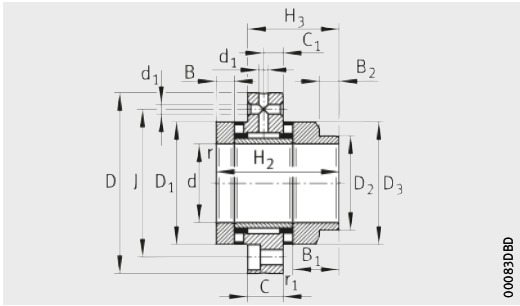

ZARF.-L

Design of housing and shaft (threaded spindle)

Mounting dimensions <sup>1)</sup>			Basic load ratings				Fatigue limit load		Limiting speeds		Bearing frictional torque	Rigidity	Tilting rigidity
			axial		radial		axial	radial					
D <sub>a</sub>	d <sub>a</sub>	t <sub>1</sub>	dyn. C <sub>a</sub>	stat. C <sub>0a</sub>	dyn. C <sub>r</sub>	stat. C <sub>0r</sub>	C <sub>ua</sub>	C <sub>ur</sub>	n <sub>G</sub> oil	n <sub>G</sub> grease	M <sub>RL</sub>	c <sub>aL</sub>	c <sub>kL</sub>
max.	min.		N	N	N	N	N	N	min <sup>-1</sup>	min <sup>-1</sup>	Nm	N/μm	Nm/mrad
53	38	0,1	64 000	141 000	22 600	36 000	12 900	5 100	6 000	1 500	1,3	2 300	400
53	38	0,1	64 000	141 000	22 600	36 000	12 900	5 100	6 000	1 500	1,3	2 300	400
63	45	0,1	80 000	199 000	24 300	41 500	18 300	5 900	4 900	1 400	1,6	3 000	800
63	45	0,1	80 000	199 000	24 300	41 500	18 300	5 900	4 900	1 400	1,6	3 000	800
69	52	0,2	107 000	265 000	26 000	47 000	22 500	6 700	4 400	1 300	2,1	3 300	1 100
69	50	0,2	107 000	265 000	26 000	47 000	22 500	6 700	4 400	1 300	2,1	3 300	1 100
74	60	0,2	105 000	265 000	27 500	53 000	22 500	7 500	4 000	1 250	2,3	3 500	1 300
74	58	0,2	105 000	265 000	27 500	53 000	22 500	7 500	4 000	1 250	2,3	3 500	1 300
79	65	0,2	117 000	315 000	38 000	74 000	26 500	10 200	3 700	1 200	2,5	3 800	1 800
79	58	0,2	117 000	315 000	38 000	74 000	26 500	10 200	3 700	1 200	2,5	3 800	1 800
91	70	0,2	154 000	405 000	40 000	82 000	36 500	11 300	3 300	1 150	3,5	4 000	2 100
91	68	0,2	154 000	405 000	40 000	82 000	36 500	11 300	3 300	1 150	3,5	4 000	2 100

Dimension table (continued) · Dimensions in mm

Designation	Mass moment of inertia <sup>2)</sup>	Axial run-out <sup>2)</sup>	Recommended INA precision locknut <sup>3)</sup>			Required locknut force <sup>4)</sup>	Rotary shaft seal to DIN 3760; to be ordered separately	Fixing screws <sup>5)</sup> DIN EN ISO 4762 10.9	
			For radial locking	For axial locking	Tightening torque <sup>6)</sup>			Size	n
	M <sub>m</sub> kg · cm <sup>2</sup>	μm			M <sub>A</sub> Nm	N			
ZARF2080-TV	1,98	1	ZMA20/52	AM20	38	17 623	—	M6	12
ZARF2080-L-TV	2,27	1	ZMA20/52	AM20	38	17 623	40×52×7	M6	12
ZARF2590-TV	3,88	1	ZMA25/58	AM25	55	20 790	—	M6	12
ZARF2590-L-TV	4,51	1	ZMA25/58	AM25	55	20 790	48×62×8	M6	12
ZARF30105-TV	6,53	1	ZMA30/65	AM30	75	24 287	—	M8	12
ZARF30105-L-TV	7,43	1	ZMA30/65	AM30	75	24 287	52×68×8	M8	12
ZARF35110-TV	8,47	1	ZMA35/70	AM35	100	27 480	—	M8	12
ZARF35110-L-TV	10,4	1	ZMA35/70	AM35	100	27 480	60×75×8	M8	12
ZARF40115-TV	13,3	1	ZMA40/75	AM40	120	29 834	—	M8	12
ZARF40115-L-TV	15,5	1	ZMA40/75	AM40	120	29 834	60×80×8	M8	12
ZARF45130-TV	23,7	1	ZMA45/85	AM45	150	33 549	—	M8	12
ZARF45130-L-TV	28,1	1	ZMA45/85	AM45	150	33 549	70×90×10	M8	12

# Needle roller/axial cylindrical roller bearings

Heavy series  
For screw mounting

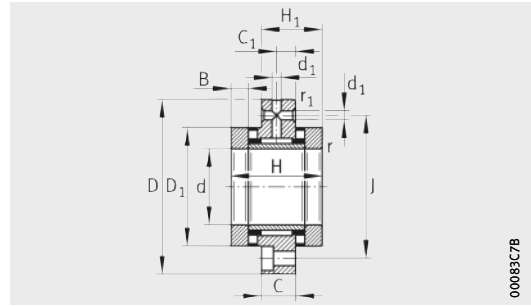

ZARF

00083C7B

**Dimension table** (continued) · Dimensions in mm

Designation	Mass m ≈ kg	Dimensions																	
		d	D	H	H <sub>1</sub>	H <sub>2</sub>	H <sub>3</sub>	C	C <sub>1</sub>	D <sub>1</sub>	D <sub>2</sub>	D <sub>3</sub>	B	B <sub>1</sub>	B <sub>2</sub>	r	r <sub>1</sub>	d <sub>1</sub>	J
<b>ZARF50140-TV</b>	4,2	<b>50</b>	140	82	51	–	–	22,5	12,5	95	–	–	17,5	–	–	0,3	0,6	6	113
<b>ZARF50140-L-TV</b>	4,65	<b>50</b>	140	–	–	103	72	22,5	12,5	95	75	93	17,5	38,5	18	0,3	0,6	6	113
<b>ZARF55145-TV</b>	4,5	<b>55</b>	145	82	51	–	–	22,5	12,5	100	–	–	17,5	–	–	0,3	0,6	6	118
<b>ZARF55145-L-TV</b>	5	<b>55</b>	145	–	–	103	72	22,5	12,5	100	80	98	17,5	38,5	18	0,3	0,6	6	118
<b>ZARF60150-TV</b>	4,7	<b>60</b>	150	82	51	–	–	22,5	12,5	105	–	–	17,5	–	–	0,3	0,6	6	123
<b>ZARF60150-L-TV</b>	5,35	<b>60</b>	150	–	–	103	72	22,5	12,5	105	90	105	17,5	38,5	18	0,3	0,6	6	123
<b>ZARF65155-TV</b>	5,1	<b>65</b>	155	82	51	–	–	22,5	12,5	110	–	–	17,5	–	–	0,3	0,6	6	128
<b>ZARF65155-L-TV</b>	5,7	<b>65</b>	155	–	–	103	72	22,5	12,5	110	90	108	17,5	38,5	18	0,3	0,6	6	128

- ① Mounting dimension for seal carrier assembly DRS, see page 146; ③ Adjacent construction, bearing screw mounted in bore;
- ④ Only valid in assembled condition.

- 1) If rotary shaft seals are used, the outside diameter of the sealing ring must be taken into consideration.
- 2) Based on rotating inner ring.
- 3) The recommended INA precision locknuts are not included in the scope of delivery and must be ordered separately.
- 4) The required axial locknut force must be observed when using other locknuts.
- 5) Tightening torque of fixing screws according to manufacturer's data. The screws are not included in the scope of delivery.
- 6) Only valid in conjunction with INA precision locknuts. Note the guidelines on locating/locating bearing arrangements, see page 54.

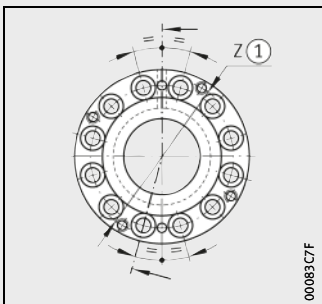

Hole pattern  
ZARF5, ZARF6

00083C7F

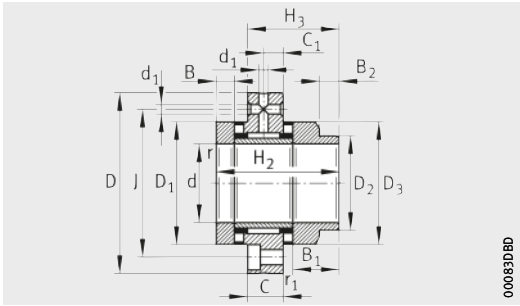

ZARF.-L

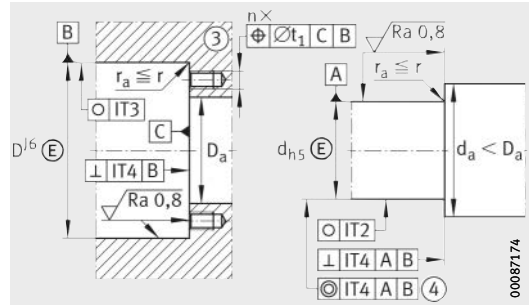

Design of housing and shaft (threaded spindle)

Mounting dimensions <sup>1)</sup>			Basic load ratings				Fatigue limit load		Limiting speeds		Bearing frictional torque	Rigidity	Tilting rigidity
			axial		radial		axial	radial					
D <sub>a</sub>	d <sub>a</sub>	t <sub>1</sub>	dyn. C <sub>a</sub>	stat. C <sub>0a</sub>	dyn. C <sub>r</sub>	stat. C <sub>0r</sub>	C <sub>ua</sub>	C <sub>ur</sub>	n <sub>G</sub> oil	n <sub>G</sub> grease	M <sub>RL</sub>	C <sub>aL</sub>	C <sub>kL</sub>
max.	min.		N	N	N	N	N	N	min <sup>-1</sup>	min <sup>-1</sup>	Nm	N/μm	Nm/mrad
96	75	0,2	172 000	480 000	42 000	90 000	43 500	12 400	3 100	1 100	3,8	4 600	2 900
96	73	0,2	172 000	480 000	42 000	90 000	43 500	12 400	3 100	1 100	3,8	4 600	2 900
101	85	0,2	177 000	500 000	44 000	98 000	46 000	13 500	2 900	1 000	4	4 900	3 600
101	78	0,2	177 000	500 000	44 000	98 000	46 000	13 500	2 900	1 000	4	4 900	3 600
106	90	0,2	187 000	550 000	44 500	92 000	50 000	12 600	2 700	950	4,2	5 300	4 300
106	88	0,2	187 000	550 000	44 500	92 000	50 000	12 600	2 700	950	4,2	5 300	4 300
111	97	0,2	172 000	500 000	54 000	104 000	46 000	14 600	2 600	900	4	4 800	4 000
111	88	0,2	172 000	500 000	54 000	104 000	46 000	14 600	2 600	900	4	4 800	4 000

Dimension table (continued) · Dimensions in mm

Designation	Mass moment of inertia <sup>2)</sup>	Axial run-out <sup>2)</sup>	Recommended INA precision locknut <sup>3)</sup>			Required locknut force <sup>4)</sup>	Rotary shaft seal to DIN 3760; to be ordered separately	Fixing screws <sup>5)</sup> DIN EN ISO 4762 10.9	
			For radial locking	For axial locking	Tightening torque <sup>6)</sup>			Size	n
	M <sub>m</sub> kg · cm <sup>2</sup>	μm			M <sub>A</sub> Nm	N			
ZARF50140-TV	29,8	1	ZMA50/92	AM50	180	36 224	–	M10	12
ZARF50140-L-TV	35,3	1	ZMA50/92	AM50	180	36 224	75×95×10	M10	12
ZARF55145-TV	36,1	1	ZMA55/98	AM55	220	39 807	–	M10	12
ZARF55145-L-TV	43	1	ZMA55/98	AM55	220	39 807	80×100×10	M10	12
ZARF60150-TV	43,8	1	ZMA60/98	AM60	250	41 144	–	M10	12
ZARF60150-L-TV	54,5	1	ZMA60/98	AM60	250	41 144	90×110×12	M10	12
ZARF65155-TV	51	1	ZMA65/105	AM65	270	40 652	–	M10	12
ZARF65155-L-TV	60,1	1	ZMA65/105	AM65	270	40 652	90×110×12	M10	12

# Needle roller/axial cylindrical roller bearings

Heavy series  
For screw mounting

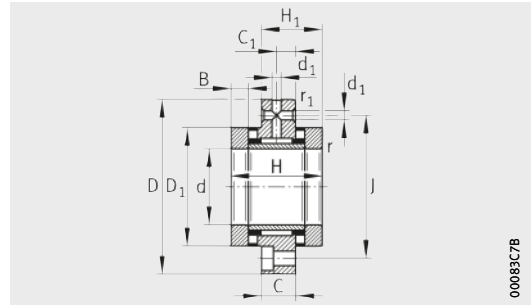

ZARF

00083C7B

**Dimension table** (continued) · Dimensions in mm

Designation	Mass m ≈ kg	Dimensions																	
		d	D	H	H <sub>1</sub>	H <sub>2</sub>	H <sub>3</sub>	C	C <sub>1</sub>	D <sub>1</sub>	D <sub>2</sub>	D <sub>3</sub>	B	B <sub>1</sub>	B <sub>2</sub>	r	r <sub>1</sub>	d <sub>1</sub>	J
<b>ZARF70160-TV</b>	5,2	<b>70</b>	160	82	51	–	–	22,5	12,5	115	–	–	17,5	–	–	0,3	0,6	6	133
<b>ZARF70160-L-TV</b>	5,95	<b>70</b>	160	–	–	103	72	22,5	12,5	115	100	115	17,5	38,5	18	0,3	0,6	6	133
<b>ZARF75185-TV</b>	9,4	<b>75</b>	185	100	62	–	–	27	15	135	–	–	21	–	–	0,3	1	6	155
<b>ZARF75185-L-TV</b>	10,6	<b>75</b>	185	–	–	125	87	27	15	135	115	135	21	46	20	0,3	1	6	155
<b>ZARF90210-TV</b>	13,7	<b>90</b>	210	110	69,5	–	–	32	17,5	160	–	–	22,5	–	–	0,3	1	8	180
<b>ZARF90210-L-TV</b>	15,1	<b>90</b>	210	–	–	135	94,5	32	17,5	160	130	158	22,5	47,5	18	0,3	1	8	180

① Mounting dimension for seal carrier assembly DRS, see page 146; ③ Adjacent construction, bearing screw mounted in bore;  
④ Only valid in assembled condition.

- 1) If rotary shaft seals are used, the outside diameter of the sealing ring must be taken into consideration.
- 2) Based on rotating inner ring.
- 3) The recommended INA precision locknuts are not included in the scope of delivery and must be ordered separately.
- 4) The required axial locknut force must be observed when using other locknuts.
- 5) Tightening torque of fixing screws according to manufacturer's data. The screws are not included in the scope of delivery.
- 6) Only valid in conjunction with INA precision locknuts. Note the guidelines on locating/locating arrangements, see page 54.

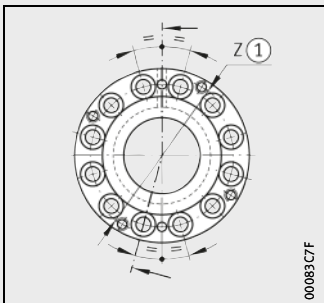

Hole pattern  
ZARF7

00083C7F

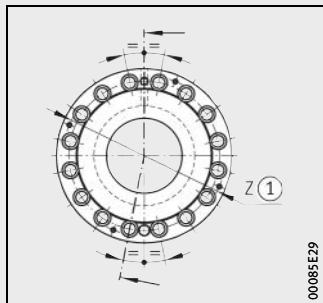

Hole pattern  
ZARF90210

00085E29

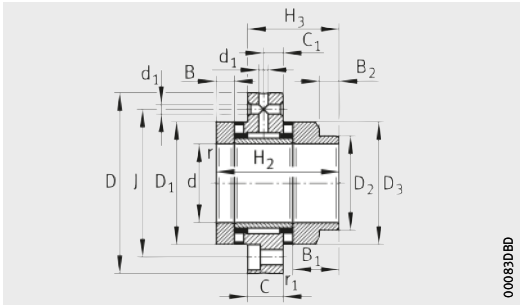

ZARF.-L

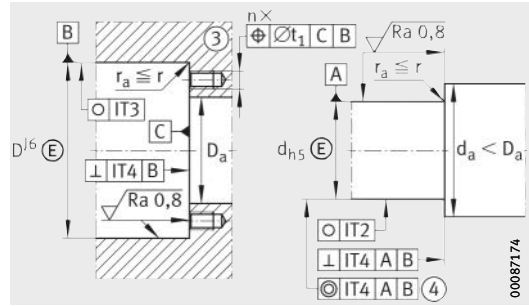

Design of housing and shaft (threaded spindle)

Mounting dimensions <sup>1)</sup>			Basic load ratings				Fatigue limit load		Limiting speeds		Bearing frictional torque	Rigidity	Tilting rigidity
			axial		radial		axial	radial					
D <sub>a</sub>	d <sub>a</sub>	t <sub>1</sub>	dyn. C <sub>a</sub>	stat. C <sub>0a</sub>	dyn. C <sub>r</sub>	stat. C <sub>0r</sub>	C <sub>ua</sub>	C <sub>ur</sub>	n <sub>G</sub> oil	n <sub>G</sub> grease	M <sub>RL</sub>	C <sub>aL</sub>	C <sub>kL</sub>
max.	min.		N	N	N	N	N	N	min <sup>-1</sup>	min <sup>-1</sup>	Nm	N/μm	Nm/mrad
116	100	0,2	201 000	630 000	56 000	119 000	57 000	15 800	2 400	800	4,8	5 800	6 000
116	98	0,2	201 000	630 000	56 000	119 000	57 000	15 800	2 400	800	4,8	5 800	6 000
136	113	0,4	290 000	890 000	72 000	132 000	84 000	18 800	2 100	700	8	6 600	8 500
136	110	0,4	290 000	890 000	72 000	132 000	84 000	18 800	2 100	700	8	6 600	8 500
161	130	0,4	325 000	1 030 000	98 000	210 000	93 000	28 500	1 800	700	10,5	7 700	14 500
161	125	0,4	325 000	1 030 000	98 000	210 000	93 000	28 500	1 800	700	10,5	7 700	14 500

Dimension table (continued) · Dimensions in mm

Designation	Mass moment of inertia <sup>2)</sup> M <sub>m</sub> kg · cm <sup>2</sup>	Axial run-out <sup>2)</sup> μm	Recommended INA precision locknut <sup>3)</sup>			Required locknut force <sup>4)</sup> axial N	Rotary shaft seal to DIN 3760; to be ordered separately	Fixing screws <sup>5)</sup> DIN EN ISO 4762 10.9	
			For radial locking	For axial locking	Tightening torque <sup>6)</sup> M <sub>A</sub> Nm			Size	n
ZARF70160-TV	62,2	1	ZMA70/110	AM70	330	46 786	-	M10	12
ZARF70160-L-TV	77,3	1	ZMA70/110	AM70	330	46 786	100×120×12	M10	12
ZARF75185-TV	149	2	ZMA75/125	AM75	580	72 971	-	M12	12
ZARF75185-L-TV	188	2	ZMA75/125	AM75	580	72 971	115×140×12	M12	12
ZARF90210-TV	312	2	ZMA90/155	AM90	960	100 669	-	M12	16
ZARF90210-L-TV	372	2	ZMA90/155	AM90	960	100 669	130×160×12	M12	16

# Needle roller/axial cylindrical roller bearings

Light series

Not for screw mounting

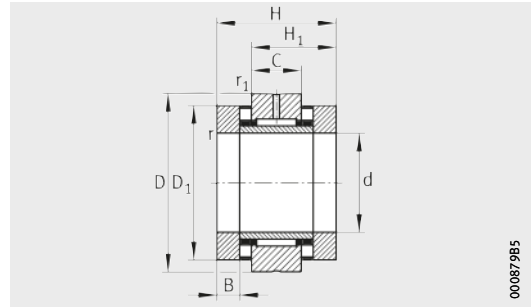

ZARN

000879B5

**Dimension table** - Dimensions in mm

Designation	Mass m ≈ kg	Dimensions														
		d	D	H	H <sub>1</sub>	H <sub>2</sub>	H <sub>3</sub>	C	D <sub>1</sub>	D <sub>2</sub>	D <sub>3</sub>	B	B <sub>1</sub>	B <sub>2</sub>	r	r <sub>1</sub>
															min.	min.
<b>ZARN1545-TV</b>	0,34	<b>15</b>	45	40	28	–	–	16	35	–	–	7,5	–	–	0,3	0,6
<b>ZARN1545-L-TV</b>	0,37	<b>15</b>	45	–	–	53	41	16	35	24	34	7,5	20,5	11	0,3	0,6
<b>ZARN1747-TV</b>	0,37	<b>17</b>	47	43	29,5	–	–	16	38	–	–	9	–	–	0,3	0,6
<b>ZARN1747-L-TV</b>	0,41	<b>17</b>	47	–	–	57	43,5	16	38	28	38	9	23	11	0,3	0,6
<b>ZARN2052-TV</b>	0,41	<b>20</b>	52	46	31	–	–	16	42	–	–	10	–	–	0,3	0,6
<b>ZARN2052-L-TV</b>	0,46	<b>20</b>	52	–	–	60	45	16	42	30	40	10	24	12	0,3	0,6
<b>ZARN2557-TV</b>	0,53	<b>25</b>	57	50	35	–	–	20	47	–	–	10	–	–	0,3	0,6
<b>ZARN2557-L-TV</b>	0,59	<b>25</b>	57	–	–	65	50	20	47	36	45	10	25	12	0,3	0,6
<b>ZARN3062-TV</b>	0,6	<b>30</b>	62	50	35	–	–	20	52	–	–	10	–	–	0,3	0,6
<b>ZARN3062-L-TV</b>	0,75	<b>30</b>	62	–	–	65	50	20	52	40	50	10	25	13	0,3	0,6

- 1) If rotary shaft seals are used, the outside diameter of the sealing ring must be taken into consideration.
- 2) Based on rotating inner ring.
- 3) The recommended INA precision locknuts are not included in the scope of delivery and must be ordered separately.
- 4) The required axial locknut force must be observed when using other locknuts.
- 5) Only valid in conjunction with INA precision locknuts. Note the guidelines on locating/locating bearing arrangements, see page 54.

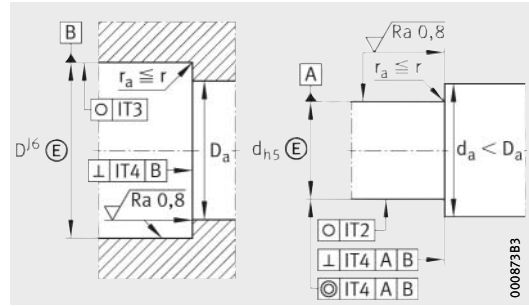
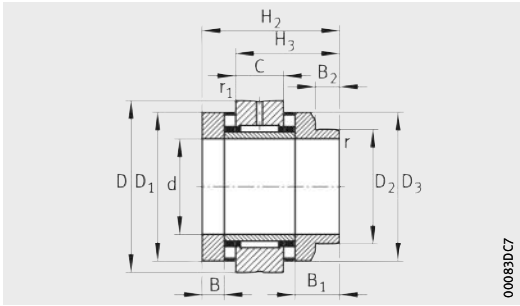

ZARN..L

Design of housing and shaft (threaded spindle)

Mounting dimensions <sup>1)</sup>		Basic load ratings				Fatigue limit load		Limiting speeds		Bearing frictional torque	Rigidity axial
		axial		radial		axial	radial	n <sub>G</sub> oil min <sup>-1</sup>	n <sub>G</sub> grease min <sup>-1</sup>		
D <sub>a</sub>	d <sub>a</sub>	dyn. C <sub>a</sub>	stat. C <sub>0a</sub>	dyn. C <sub>r</sub>	stat. C <sub>0r</sub>	C <sub>ua</sub>	C <sub>ur</sub>				
max.	min.	N	N	N	N	N	N			Nm	N/μm
36	28	24 900	53 000	13 000	17 500	7 300	2 600	8 500	2 200	0,35	1 400
36	22	24 900	53 000	13 000	17 500	7 300	2 600	8 500	2 200	0,35	1 400
39	28	26 000	57 000	14 000	19 900	7 900	2 950	7 800	2 100	0,4	1 600
39	26	26 000	57 000	14 000	19 900	7 900	2 950	7 800	2 100	0,4	1 600
43	33	33 500	76 000	14 900	22 400	6 300	3 350	7 000	2 000	0,5	1 800
43	28	33 500	76 000	14 900	22 400	6 300	3 350	7 000	2 000	0,5	1 800
48	39	35 500	86 000	22 600	36 000	7 100	5 100	6 000	1 900	0,55	1 900
48	34	35 500	86 000	22 600	36 000	7 100	5 100	6 000	1 900	0,55	1 900
53	44	39 000	101 000	24 300	41 500	8 400	5 900	5 500	1 800	0,65	2 200
53	38	39 000	101 000	24 300	41 500	8 400	5 900	5 500	1 800	0,65	2 200

Dimension table (continued) · Dimensions in mm

Designation	Tilting rigidity  c <sub>kL</sub> Nm/mrad	Mass moment of inertia <sup>2)</sup>  M <sub>m</sub> kg · cm <sup>2</sup>	Axial run-out <sup>2)</sup>  μm	Recommended INA precision locknut <sup>3)</sup>			Required locknut force <sup>4)</sup> axial N	Rotary shaft seal to DIN 3760; to be ordered separately
				For radial locking	For axial locking	Tightening torque <sup>5)</sup> M <sub>A</sub> Nm		
ZARN1545-TV	110	0,24	1	ZMA15/33	AM15	10	6 506	–
ZARN1545-L-TV	110	0,274	1	ZMA15/33	AM15	10	6 506	24×35×7
ZARN1747-TV	160	0,373	1	ZM17	AM17	12	7 078	–
ZARN1747-L-TV	160	0,464	1	ZM17	AM17	12	7 078	28×40×7
ZARN2052-TV	230	0,615	1	ZMA20/38	AM20	18	8 972	–
ZARN2052-L-TV	230	0,683	1	ZMA20/38	AM20	18	8 972	30×42×7
ZARN2557-TV	350	0,989	1	ZMA25/45	AM25	25	9 745	–
ZARN2557-L-TV	350	1,15	1	ZMA25/45	AM25	25	9 745	36×47×7
ZARN3062-TV	520	1,46	1	ZMA30/52	AM30	32	10 662	–
ZARN3062-L-TV	520	1,7	1	ZMA30/52	AM30	32	10 662	40×52×7

# Needle roller/axial cylindrical roller bearings

Light series

Not for screw mounting

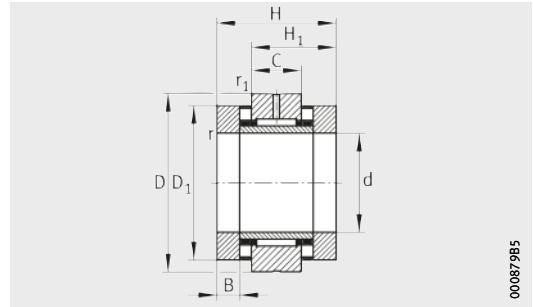

ZARN

000879B5

**Dimension table** (continued) · Dimensions in mm

Designation	Mass m ≈ kg	Dimensions														
		d	D	H	H <sub>1</sub>	H <sub>2</sub>	H <sub>3</sub>	C	D <sub>1</sub>	D <sub>2</sub>	D <sub>3</sub>	B	B <sub>1</sub>	B <sub>2</sub>	r	r <sub>1</sub>
															min.	min.
<b>ZARN3570-TV</b>	0,8	<b>35</b>	70	54	37	–	–	20	60	–	–	11	–	–	0,3	0,6
<b>ZARN3570-L-TV</b>	0,93	<b>35</b>	70	–	–	70	53	20	60	45	58	11	27	13	0,3	0,6
<b>ZARN4075-TV</b>	0,9	<b>40</b>	75	54	37	–	–	20	65	–	–	11	–	–	0,3	0,6
<b>ZARN4075-L-TV</b>	1	<b>40</b>	75	–	–	70	53	20	65	50	63	11	27	14	0,3	0,6
<b>ZARN4580-TV</b>	1,12	<b>45</b>	80	60	42,5	–	–	25	70	–	–	11,5	–	–	0,3	0,6
<b>ZARN4580-L-TV</b>	1,27	<b>45</b>	80	–	–	75	57,5	25	70	56	68	11,5	26,5	13	0,3	0,6
<b>ZARN5090-TV</b>	1,43	<b>50</b>	90	60	42,5	–	–	25	78	–	–	11,5	–	–	0,3	0,6
<b>ZARN5090-L-TV</b>	1,78	<b>50</b>	90	–	–	78	60,5	25	78	60	78	11,5	29,5	14	0,3	0,6

<sup>1)</sup> If rotary shaft seals are used, the outside diameter of the sealing ring must be taken into consideration.

<sup>2)</sup> Based on rotating inner ring.

<sup>3)</sup> The recommended INA precision locknuts are not included in the scope of delivery and must be ordered separately.

<sup>4)</sup> The required axial locknut force must be observed when using other locknuts.

<sup>5)</sup> Only valid in conjunction with INA precision locknuts. Note the guidelines on locating/locating bearing arrangements, see page 54.



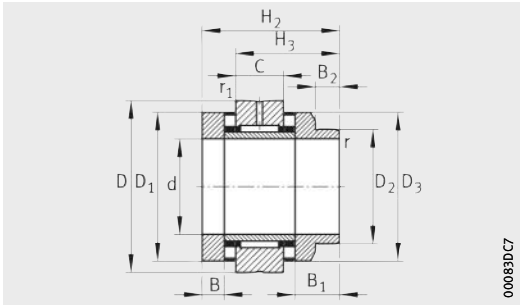

ZARN..L

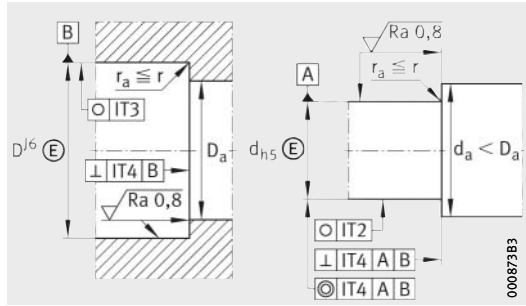

Design of housing and shaft (threaded spindle)

Mounting dimensions <sup>1)</sup>		Basic load ratings				Fatigue limit load		Limiting speeds		Bearing frictional torque	Rigidity
D <sub>a</sub>	d <sub>a</sub>	axial		radial		axial	radial	n <sub>G</sub> oil min <sup>-1</sup>	n <sub>G</sub> grease min <sup>-1</sup>	M <sub>RL</sub> Nm	axial
		dyn. C <sub>a</sub> N	stat. C <sub>0a</sub> N	dyn. C <sub>r</sub> N	stat. C <sub>0r</sub> N	C <sub>ua</sub> N	C <sub>ur</sub> N				C <sub>aL</sub> N/μm
61	50	56 000	148 000	26 000	47 000	12 800	6 700	4 800	1 700	0,9	2 600
61	43	56 000	148 000	26 000	47 000	12 800	6 700	4 800	1 700	0,9	2 600
66	55	59 000	163 000	27 500	53 000	14 100	7 500	4 400	1 600	1	2 800
66	48	59 000	163 000	27 500	53 000	14 100	7 500	4 400	1 600	1	2 800
71	60	61 000	177 000	38 000	74 000	15 400	10 200	4 000	1 500	1,2	3 000
71	54	61 000	177 000	38 000	74 000	15 400	10 200	4 000	1 500	1,2	3 000
79	67	90 000	300 000	40 000	82 000	27 500	11 300	3 600	1 200	2,2	4 800
79	58	90 000	300 000	40 000	82 000	27 500	11 300	3 600	1 200	2,2	4 800

Dimension table (continued) · Dimensions in mm

Designation	Tilting rigidity c <sub>KL</sub> Nm/mrad	Mass moment of inertia <sup>2)</sup> M <sub>m</sub> kg · cm <sup>2</sup>	Axial run-out <sup>2)</sup> μm	Recommended INA precision locknut <sup>3)</sup>			Required locknut force <sup>4)</sup> axial N	Rotary shaft seal to DIN 3760; to be ordered separately
				For radial locking	For axial locking	Tightening torque <sup>5)</sup> M <sub>A</sub> Nm		
ZARN3570-TV	740	2,8	1	ZMA35/58	AM35/58	40	12 143	-
ZARN3570-L-TV	740	3,21	1	ZMA35/58	AM35/58	40	12 143	45×60×8
ZARN4075-TV	1 030	3,78	1	ZMA40/62	AM40	55	14 240	-
ZARN4075-L-TV	1 030	4,35	1	ZMA40/62	AM40	55	14 240	50×65×8
ZARN4580-TV	1 340	5,33	1	ZMA45/68	AM45	65	15 112	-
ZARN4580-L-TV	1 340	6,03	1	ZMA45/68	AM45	65	15 112	56×70×8
ZARN5090-TV	2 470	8,42	1	ZMA50/75	AM50	85	18 410	-
ZARN5090-L-TV	2 470	10,46	1	ZMA50/75	AM50	85	18 410	60×80×8

# Needle roller/axial cylindrical roller bearings

Heavy series

Not for screw mounting

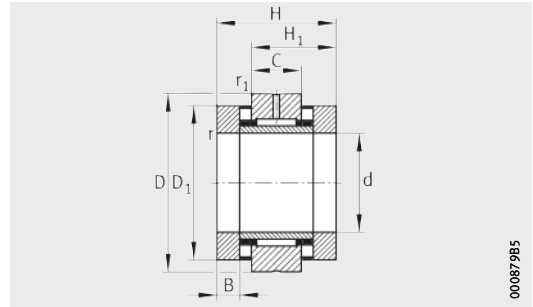

ZARN

000879B5

**Dimension table** - Dimensions in mm

Designation	Mass m ≈ kg	Dimensions															
		d	D	H	H <sub>1</sub>	H <sub>2</sub>	H <sub>3</sub>	C	D <sub>1</sub>	D <sub>2</sub>	D <sub>3</sub>	B	B <sub>1</sub>	B <sub>2</sub>	r	r <sub>1</sub>	
																min.	min.
<b>ZARN2062-TV</b>	0,87	<b>20</b>	62	60	40	–	–	20	52	–	–	12,5	–	–	0,3	0,6	
<b>ZARN2062-L-TV</b>	0,99	<b>20</b>	62	–	–	75	55	20	52	40	50	12,5	27,5	13	0,3	0,6	
<b>ZARN2572-TV</b>	1,17	<b>25</b>	72	60	40	–	–	20	62	–	–	12,5	–	–	0,3	0,6	
<b>ZARN2572-L-TV</b>	1,32	<b>25</b>	72	–	–	75	55	20	62	48	60	12,5	27,5	13	0,3	0,6	
<b>ZARN3080-TV</b>	1,5	<b>30</b>	80	66	43	–	–	20	68	–	–	14	–	–	0,3	0,6	
<b>ZARN3080-L-TV</b>	1,7	<b>30</b>	80	–	–	82	59	20	68	52	66	14	30	13	0,3	0,6	
<b>ZARN3585-TV</b>	1,65	<b>35</b>	85	66	43	–	–	20	73	–	–	14	–	–	0,3	0,6	
<b>ZARN3585-L-TV</b>	1,8	<b>35</b>	85	–	–	82	59	20	73	60	73	14	30	13	0,3	0,6	

<sup>1)</sup> If rotary shaft seals are used, the outside diameter of the sealing ring must be taken into consideration.

<sup>2)</sup> Based on rotating inner ring.

<sup>3)</sup> The recommended INA precision locknuts are not included in the scope of delivery and must be ordered separately.

<sup>4)</sup> The required axial locknut force must be observed when using other locknuts.

<sup>5)</sup> Only valid in conjunction with INA precision locknuts. Note the guidelines on locating/locating bearing arrangements, see page 54.

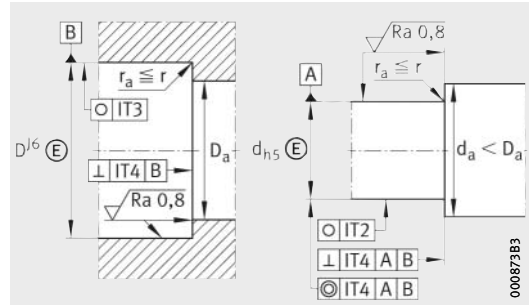
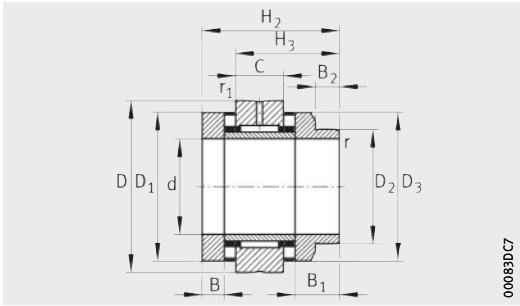

ZARN..L

Design of housing and shaft (threaded spindle)

Mounting dimensions <sup>1)</sup>		Basic load ratings				Fatigue limit load		Limiting speeds		Bearing frictional torque	Rigidity
D <sub>a</sub> max.	d <sub>a</sub> min.	axial		radial		C <sub>ua</sub> N	C <sub>ur</sub> N	n <sub>G</sub> oil min <sup>-1</sup>	n <sub>G</sub> grease min <sup>-1</sup>	M <sub>RL</sub> Nm	c <sub>aL</sub> N/μm
		dyn. C <sub>a</sub> N	stat. C <sub>0a</sub> N	dyn. C <sub>r</sub> N	stat. C <sub>0r</sub> N						
53	38	64 000	141 000	22 600	36 000	12 900	5 100	6 000	1 500	1,3	2 300
53	38	64 000	141 000	22 600	36 000	12 900	5 100	6 000	1 500	1,3	2 300
63	45	80 000	199 000	24 300	41 500	18 300	5 900	4 900	1 400	1,6	3 000
63	45	80 000	199 000	24 300	41 500	18 300	5 900	4 900	1 400	1,6	3 000
69	52	107 000	265 000	26 000	47 000	22 500	6 700	4 400	1 300	2,1	3 300
69	50	107 000	265 000	26 000	47 000	22 500	6 700	4 400	1 300	2,1	3 300
74	60	105 000	265 000	27 500	53 000	22 500	7 500	4 000	1 250	2,3	3 500
74	58	105 000	265 000	27 500	53 000	22 500	7 500	4 000	1 250	2,3	3 500

Dimension table (continued) · Dimensions in mm

Designation	Tilting rigidity  c <sub>KL</sub> Nm/mrad	Mass moment of inertia <sup>2)</sup>  M <sub>m</sub> kg · cm <sup>2</sup>	Axial run-out <sup>2)</sup>  μm	Recommended INA precision locknut <sup>3)</sup>			Required locknut force <sup>4)</sup>  axial N	Rotary shaft seal to DIN 3760; to be ordered separately
				For radial locking	For axial locking	Tightening torque <sup>5)</sup> M <sub>A</sub> Nm		
ZARN2062-TV	400	1,98	1	ZMA20/52	AM20	38	17 623	-
ZARN2062-L-TV	400	2,27	1	ZMA20/52	AM20	38	17 623	40×52×7
ZARN2572-TV	800	3,88	1	ZMA25/58	AM25	55	20 790	-
ZARN2572-L-TV	800	4,51	1	ZMA25/58	AM25	55	20 790	48×62×8
ZARN3080-TV	1 100	6,53	1	ZMA30/65	AM30	75	24 287	-
ZARN3080-L-TV	1 100	7,43	1	ZMA30/65	AM30	75	24 287	52×68×8
ZARN3585-TV	1 300	8,47	1	ZMA35/70	AM35	100	27 480	-
ZARN3585-L-TV	1 300	10,4	1	ZMA35/70	AM35	100	27 480	60×75×8

# Needle roller/axial cylindrical roller bearings

Heavy series

Not for screw mounting

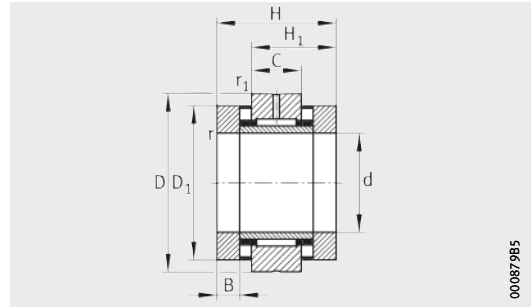

ZARN

000879B5

**Dimension table** (continued) · Dimensions in mm

Designation	Mass m ≈ kg	Dimensions															
		d	D	H	H <sub>1</sub>	H <sub>2</sub>	H <sub>3</sub>	C	D <sub>1</sub>	D <sub>2</sub>	D <sub>3</sub>	B	B <sub>1</sub>	B <sub>2</sub>	r	r <sub>1</sub>	
																min.	min.
<b>ZARN4090-TV</b>	2,09	<b>40</b>	90	75	50	–	–	25	78	–	–	16	–	–	0,3	0,6	
<b>ZARN4090-L-TV</b>	2,39	<b>40</b>	90	–	–	93	68	25	78	60	78	16	34	14	0,3	0,6	
<b>ZARN45105-TV</b>	3,02	<b>45</b>	105	82	53,5	–	–	25	90	–	–	17,5	–	–	0,3	0,6	
<b>ZARN45105-L-TV</b>	3,42	<b>45</b>	105	–	–	103	74,5	25	90	70	88	17,5	38,5	18	0,3	0,6	
<b>ZARN50110-TV</b>	3,3	<b>50</b>	110	82	53,5	–	–	25	95	–	–	17,5	–	–	0,3	0,6	
<b>ZARN50110-L-TV</b>	3,75	<b>50</b>	110	–	–	103	74,5	25	95	75	93	17,5	38,5	18	0,3	0,6	
<b>ZARN55115-TV</b>	3,5	<b>55</b>	115	82	53,5	–	–	25	100	–	–	17,5	–	–	0,3	0,6	
<b>ZARN55115-L-TV</b>	4	<b>55</b>	115	–	–	103	74,5	25	100	80	98	17,5	38,5	18	0,3	0,6	

<sup>1)</sup> If rotary shaft seals are used, the outside diameter of the sealing ring must be taken into consideration.

<sup>2)</sup> Based on rotating inner ring.

<sup>3)</sup> The recommended INA precision locknuts are not included in the scope of delivery and must be ordered separately.

<sup>4)</sup> The required axial locknut force must be observed when using other locknuts.

<sup>5)</sup> Only valid in conjunction with INA precision locknuts. Note the guidelines on locating/locating bearing arrangements, see page 54.

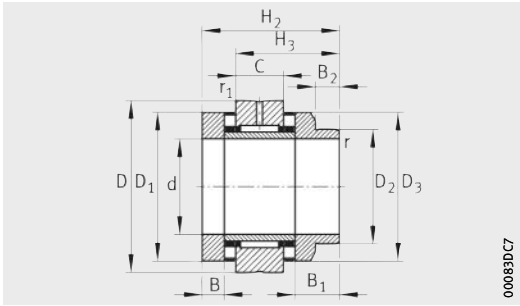

ZARN..L

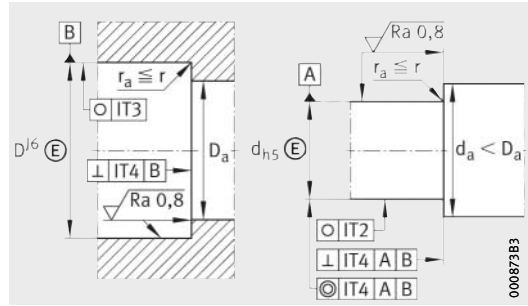

Design of housing and shaft (threaded spindle)

Mounting dimensions <sup>1)</sup>		Basic load ratings				Fatigue limit load		Limiting speeds		Bearing frictional torque	Rigidity axial
		axial		radial		axial	radial	n <sub>G</sub> oil min <sup>-1</sup>	n <sub>G</sub> grease min <sup>-1</sup>		
D <sub>a</sub> max.	d <sub>a</sub> min.	dyn. C <sub>a</sub> N	stat. C <sub>0a</sub> N	dyn. C <sub>r</sub> N	stat. C <sub>0r</sub> N	C <sub>ua</sub> N	C <sub>ur</sub> N				
79	65	117 000	315 000	38 000	74 000	26 500	10 200	3 700	1 200	2,5	3 800
79	58	117 000	315 000	38 000	74 000	26 500	10 200	3 700	1 200	2,5	3 800
91	70	154 000	405 000	40 000	82 000	36 500	11 300	3 300	1 150	3,5	4 000
91	68	154 000	405 000	40 000	82 000	36 500	11 300	3 300	1 150	3,5	4 000
96	75	172 000	480 000	42 000	90 000	43 500	12 400	3 100	1 100	3,8	4 600
96	73	172 000	480 000	42 000	90 000	43 500	12 400	3 100	1 100	3,8	4 600
101	85	177 000	500 000	44 000	98 000	46 000	13 500	2 900	1 000	4	4 900
101	78	177 000	500 000	44 000	98 000	46 000	13 500	2 900	1 000	4	4 900

Dimension table (continued) · Dimensions in mm

Designation	Tilting rigidity  c <sub>kL</sub> Nm/mrad	Mass moment of inertia <sup>2)</sup>  M <sub>m</sub> kg · cm <sup>2</sup>	Axial run-out <sup>2)</sup>  μm	Recommended INA precision locknut <sup>3)</sup>			Required locknut force <sup>4)</sup> axial N	Rotary shaft seal to DIN 3760; to be ordered separately
				For radial locking	For axial locking	Tightening torque <sup>5)</sup> M <sub>A</sub> Nm		
<b>ZARN4090-TV</b>	1 800	13,3	1	<b>ZMA40/75</b>	<b>AM40</b>	120	29 834	–
<b>ZARN4090-L-TV</b>	1 800	15,5	1	<b>ZMA40/75</b>	<b>AM40</b>	120	29 834	60×80×8
<b>ZARN45105-TV</b>	2 100	23,7	1	<b>ZMA45/85</b>	<b>AM45</b>	150	33 549	–
<b>ZARN45105-L-TV</b>	2 100	28,1	1	<b>ZMA45/85</b>	<b>AM45</b>	150	33 549	70×90×10
<b>ZARN50110-TV</b>	2 900	29,8	1	<b>ZMA50/92</b>	<b>AM50</b>	180	36 224	–
<b>ZARN50110-L-TV</b>	2 900	35,3	1	<b>ZMA50/92</b>	<b>AM50</b>	180	36 224	75×95×10
<b>ZARN55115-TV</b>	3 600	36,1	1	<b>ZMA55/98</b>	<b>AM55</b>	220	39 807	–
<b>ZARN55115-L-TV</b>	3 600	43	1	<b>ZMA55/98</b>	<b>AM55</b>	220	39 807	80×100×10

# Needle roller/axial cylindrical roller bearings

Heavy series

Not for screw mounting

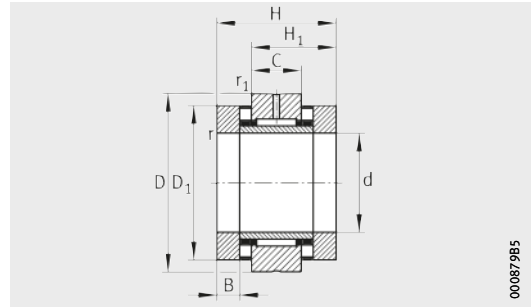

ZARN

000879B5

**Dimension table** (continued) · Dimensions in mm

Designation	Mass m ≈ kg	Dimensions															
		d	D	H	H <sub>1</sub>	H <sub>2</sub>	H <sub>3</sub>	C	D <sub>1</sub>	D <sub>2</sub>	D <sub>3</sub>	B	B <sub>1</sub>	B <sub>2</sub>	r	r <sub>1</sub>	
																min.	min.
<b>ZARN60120-TV</b>	3,7	<b>60</b>	120	82	53,5	–	–	25	105	–	–	17,5	–	–	0,3	0,6	
<b>ZARN60120-L-TV</b>	4,85	<b>60</b>	120	–	–	103	74,5	25	105	90	105	17,5	38,5	18	0,3	0,6	
<b>ZARN65125-TV</b>	4	<b>65</b>	125	82	53,5	–	–	25	110	–	–	17,5	–	–	0,3	0,6	
<b>ZARN65125-L-TV</b>	4,6	<b>65</b>	125	–	–	103	74,5	25	110	90	108	17,5	38,5	18	0,3	0,6	
<b>ZARN70130-TV</b>	4,1	<b>70</b>	130	82	53,5	–	–	25	115	–	–	17,5	–	–	0,3	0,6	
<b>ZARN70130-L-TV</b>	4,85	<b>70</b>	130	–	–	103	74,5	25	115	100	115	17,5	38,5	18	0,3	0,6	
<b>ZARN75155-TV</b>	7,9	<b>75</b>	155	100	65	–	–	30	135	–	–	21	–	–	0,3	1	
<b>ZARN75155-L-TV</b>	9,1	<b>75</b>	155	–	–	125	90	30	135	115	135	21	46	20	0,3	1	
<b>ZARN90180-TV</b>	11,8	<b>90</b>	180	110	72,5	–	–	35	160	–	–	22,5	–	–	0,3	1	
<b>ZARN90180-L-TV</b>	13,2	<b>90</b>	180	–	–	135	97,5	35	160	130	158	22,5	47,5	18	0,3	1	

- 1) If rotary shaft seals are used, the outside diameter of the sealing ring must be taken into consideration.
- 2) Based on rotating inner ring.
- 3) The recommended INA precision locknuts are not included in the scope of delivery and must be ordered separately.
- 4) The required axial locknut force must be observed when using other locknuts.
- 5) Only valid in conjunction with INA precision locknuts. Note the guidelines on locating/locating bearing arrangements, see page 54.

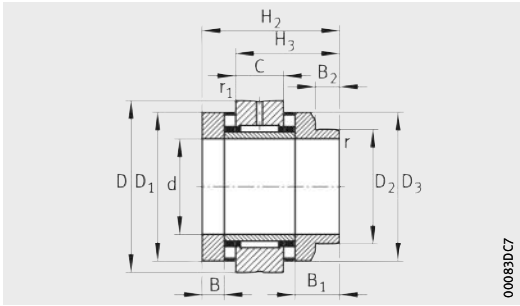

ZARN..L

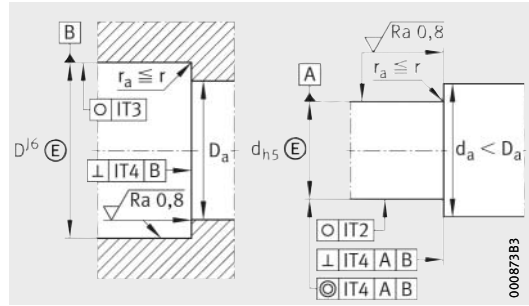

Design of housing and shaft (threaded spindle)

Mounting dimensions <sup>1)</sup>		Basic load ratings				Fatigue limit load		Limiting speeds		Bearing frictional torque	Rigidity
		axial		radial		axial	radial	n <sub>G</sub> oil min <sup>-1</sup>	n <sub>G</sub> grease min <sup>-1</sup>		
D <sub>a</sub> max.	d <sub>a</sub> min.	dyn. C <sub>a</sub> N	stat. C <sub>0a</sub> N	dyn. C <sub>r</sub> N	stat. C <sub>0r</sub> N	C <sub>ua</sub> N	C <sub>ur</sub> N			M <sub>RL</sub> Nm	C <sub>aL</sub> N/μm
106	90	187 000	550 000	44 500	92 000	50 000	12 600	2 700	950	4,2	5 300
106	88	187 000	550 000	44 500	92 000	50 000	12 600	2 700	950	4,2	5 300
111	97	172 000	500 000	54 000	104 000	46 000	14 600	2 600	900	4	4 800
111	88	172 000	500 000	54 000	104 000	46 000	14 600	2 600	900	4	4 800
116	100	201 000	630 000	56 000	119 000	57 000	15 800	2 400	800	4,8	5 800
116	98	201 000	630 000	56 000	119 000	57 000	15 800	2 400	800	4,8	5 800
136	113	290 000	890 000	72 000	132 000	84 000	18 800	2 100	700	8	6 600
136	110	290 000	890 000	72 000	132 000	84 000	18 800	2 100	700	8	6 600
161	130	325 000	1 030 000	98 000	210 000	93 000	28 500	1 800	700	10,5	7 700
161	125	325 000	1 030 000	98 000	210 000	93 000	28 500	1 800	700	10,5	7 700

Dimension table (continued) · Dimensions in mm

Designation	Tilting rigidity c <sub>kL</sub> Nm/mrad	Mass moment of inertia <sup>2)</sup> M <sub>m</sub> kg · cm <sup>2</sup>	Axial run-out <sup>2)</sup> μm	Recommended INA precision locknut <sup>3)</sup>			Required locknut force <sup>4)</sup> axial N	Rotary shaft seal to DIN 3760; to be ordered separately
				For radial locking	For axial locking	Tightening torque <sup>5)</sup> M <sub>A</sub> Nm		
ZARN60120-TV	4 300	43,8	1	ZMA60/98	AM60	250	41 144	–
ZARN60120-L-TV	4 300	54,5	1	ZMA60/98	AM60	250	41 144	90×110×12
ZARN65125-TV	4 000	51	1	ZMA65/105	AM65	270	40 652	–
ZARN65125-L-TV	4 000	60,1	1	ZMA65/105	AM65	270	40 652	90×110×12
ZARN70130-TV	6 000	62,2	1	ZMA70/110	AM70	330	46 786	–
ZARN70130-L-TV	6 000	77,3	1	ZMA70/110	AM70	330	46 786	100×120×12
ZARN75155-TV	8 500	149	2	ZMA75/125	AM75	580	72 971	–
ZARN75155-L-TV	8 500	188	2	ZMA75/125	AM75	580	72 971	115×140×12
ZARN90180-TV	14 500	312	2	ZMA90/155	AM90	960	100 669	–
ZARN90180-L-TV	14 500	372	2	ZMA90/155	AM90	960	100 669	130×160×12



**FAG**



## Accessories

Seal carrier assemblies

Precision locknuts

Sockets

BEARINX-online Easy BallScrew



# Accessories

	Page
<b>Product overview</b>	Seal carrier assemblies, precision locknuts, sockets, calculation of screw drive bearing arrangements ..... 136
<b>Features</b>	Seal carrier assemblies..... 137
	Operating temperature ..... 137
	Limiting speeds..... 138
	Precision locknuts ..... 139
<b>Design and safety guidelines</b>	Breakaway torque..... 141
	Ultimate axial load ..... 141
	Mounting guidelines..... 141
<b>Accuracy</b>	..... 145
<b>Dimension tables</b>	Seal carrier assemblies DRS..... 146
	Precision locknuts AM, for axial locking ..... 148
	Precision locknuts ZM, ZMA, for radial locking..... 149
	Sockets ..... 151
<b>Calculation of screw drive bearing arrangements</b>	BEARINX-online ..... 154
	Module Easy BallScrew..... 154
	User-friendly interface ..... 155
	Data interchange with Schaeffler ..... 156



# Product overview Accessories

## Seal carrier assemblies

DRS

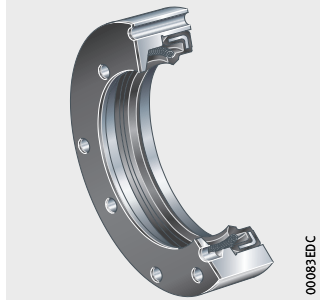

## Precision locknuts

For axial locking  
For radial locking

AM

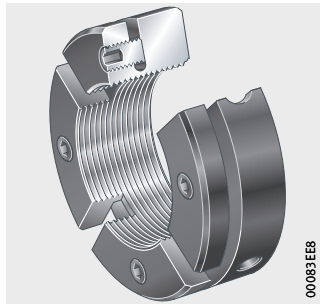

ZM, ZMA

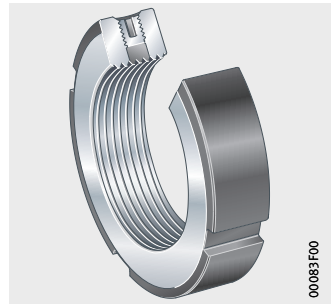

## Sockets

AMS

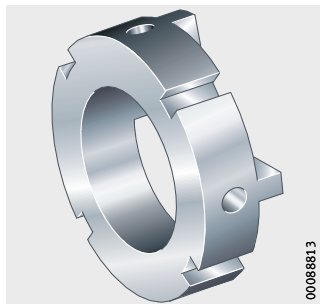

LOCKNUT-SOCKET-KM

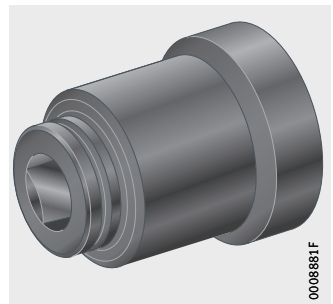

## Calculation of screw drive bearing arrangements

BEARINX-online Easy BallScrew



# Accessories

## Features

### Seal carrier assemblies

Seal carrier assemblies DRS are screw mounted to the outer ring of needle roller/axial cylindrical roller bearings ZARF(L) and precisely centred in this position, *Figure 1*. They seal the bearings against outside influences.

The sealing elements are supplied as a complete set of individual parts and comprise:

- a seal carrier
- a rotary shaft seal to DIN 3760, with an elastomer part made from NBR
- a gasket
- hexagonal socket head screws for fixing the carrier to the central washer of the bearing.

DRS  
ZMA  
ZARF.-L

- ① Seal carrier assembly DRS
- ② Precision locknut ZM or ZMA
- ③ Rotary shaft seal DIN 3760

*Figure 1*  
Needle roller/axial  
cylindrical roller bearing  
with seal carrier assembly

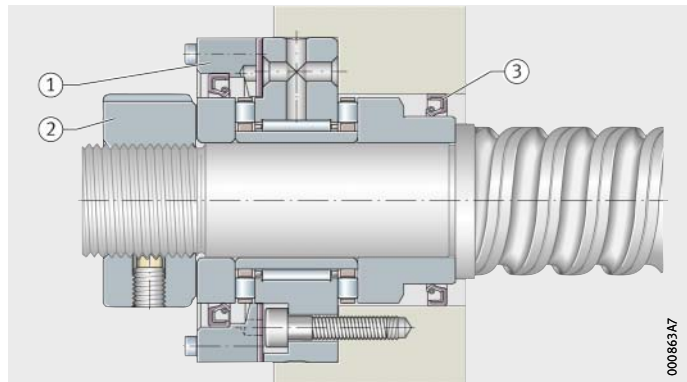

### Operating temperature

Seal carrier assemblies are suitable for operating temperatures from  $-30\text{ }^{\circ}\text{C}$  to  $+120\text{ }^{\circ}\text{C}$ , restricted by the seal material.



# Accessories

## Limiting speeds

The limiting speeds for rotary shaft seals made from NBR conform to DIN 3760, *Figure 2*. These may be lower than the limiting speeds of the bearings. For the bearing arrangement, the lower of the two limiting speeds is always the decisive factor.

$v$  = circumferential velocity  
 $d$  = seal lip diameter of seal carrier assembly DRS  
 $n$  = speed

*Figure 2*  
 Limiting speeds under pressure-free operation for rotary shaft seals

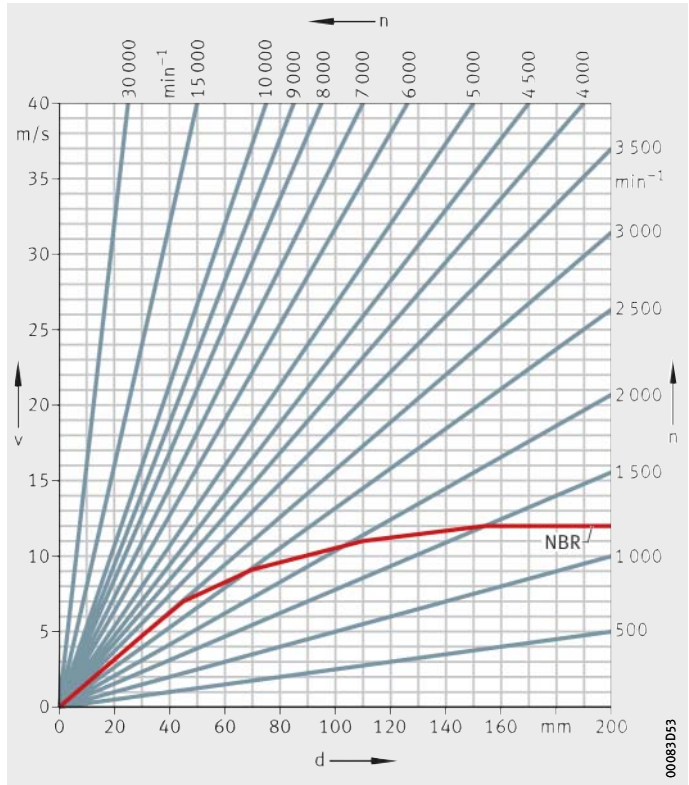

## Precision locknuts

Precision locknuts are used where high axial forces must be supported and high axial runout accuracy and rigidity are required, *Figure 3, Figure 4, page 140.*

The thread and the axial face of the locknut in contact with the rolling bearing are produced in a single clamping operation. This allows very high axial runout accuracy to be achieved.

The available precision locknuts AM, ZM and ZMA can be used several times if handled correctly.

## Axial locking by segments

Precision locknuts AM with axial locking are divided into several segments for applying the locking forces. When the hexagonal socket grub screws are tightened, the segments are elastically deformed. As a result, the thread flanks of the segments are pressed against the flanks of the shaft thread and give a high frictional force that acts to prevent loosening of the nut. The axial runout of the nut is not affected by this method of locking.

**AM**  
**ZKLF..-2RS**

① Precision locknut AM

*Figure 3*  
Mounting clearance  
with locknut AM for axial locking

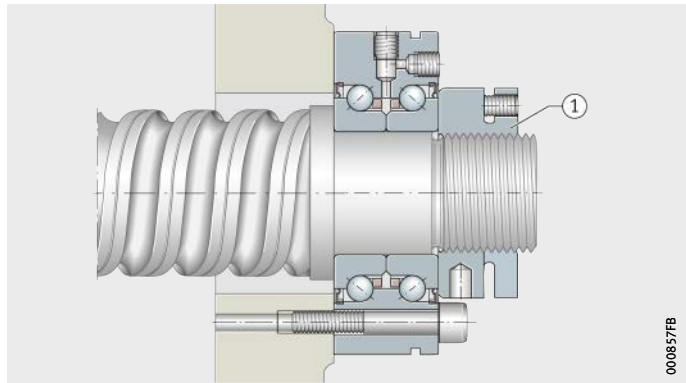

## Accessories

### Locking by radial locking pegs

Precision locknuts ZM and ZMA are secured against rotation by means of two radially acting locking pegs, *Figure 4*. ZMA is the heavy series.

The locking pegs are manufactured together with the internal thread of the locknut. They mesh like comb teeth in the thread of the shaft without affecting the axial runout or damaging the thread.

The locking pegs are secured by grub screws with a hexagonal socket arranged concentrically over the locking pegs.

- DRS**  
**ZMA**  
**ZARF..L**
- ① Precision locknut ZM or ZMA
  - ② Locking peg
  - ③ Grub screw

*Figure 4*  
Mounting clearance  
with locknut ZM, ZMA  
for radial locking

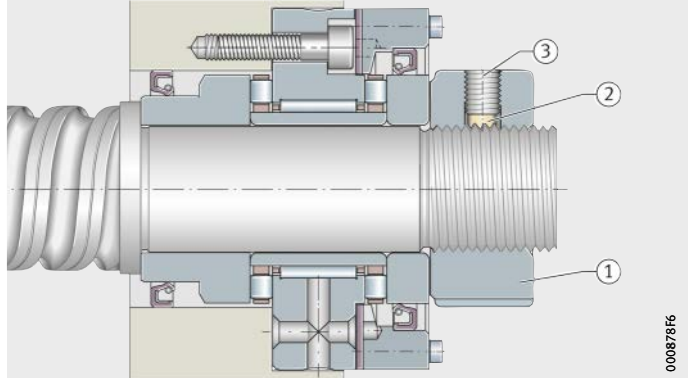

## Design and safety guidelines

Shaft threads for the precision locknuts must be precision machined, see table.

### Recommended shaft thread

Shaft thread to DIN 13-21 to DIN 13-24	
Tolerance class	
Medium	Fine
6g	4h



The journal thread must support the locknut over its whole width.

### Breakaway torque

The breakaway torques  $M_L$  given in the dimension tables are based on a locknut tightened against a rigid shaft shoulder to the reference tightening torque  $M_{AL}$  and secured.

### Ultimate axial load

The axial ultimate loads  $F_{aB}$  are valid for a journal thread of tolerance class 6g or better and a minimum strength of  $700 \text{ N/mm}^2$ .

For dynamic loading, the permissible value can be taken as 75% of the ultimate load  $F_{aB}$ .

### Mounting guidelines

The characteristics of the bearings are only valid when used in combination with INA precision locknuts and the associated tightening torques given in the dimension tables.



Locknuts must be fully screwed onto the shaft thread.

Bearings should only be mounted and dismantled in accordance with the Mounting and Maintenance Manual TPI 100.

### Further information

- TPI 100, Bearings for Screw Drives, Mounting and Maintenance Manual
- Download and ordering: <http://medien.schaeffler.de>.



## Accessories

### Precision locknuts for axial locking

Precision locknuts AM for axial locking can be tightened using a hook wrench of type B to DIN 1810 that engages in four, six or eight holes around the circumference, *Figure 5*.

The grub screws are then tightened in a crosswise sequence to the specified tightening torque  $M_A$  using an Allen key. Dismounting is carried out by uniformly loosening the grub screws of all segments in order to prevent a single segment being left tensioned.



Tightening by means of just one segment is not permissible. For tightening, a socket AMS can be used that ensures uniform loading of all segments. The socket AMS must be ordered separately, see page 151.

For tightening using the socket AMS, a hook wrench of type B or type A to DIN 1810 or an FAG socket can be used, see page 144.

If precision locknuts AM are fitted using the socket AMS, a maximum of twice the tightening torque of the bearing according to the dimension table is permissible.

Segments can be axially deformed if the grub screws are not tightened uniformly in a crosswise sequence or the locknut AM is not fully screwed onto the shaft thread. The specified tightening torque  $M_A$  in the dimension table must be observed.

- ① Socket AMS
- ② Hook wrench type A to DIN 1810
- ③ Hook wrench type B to DIN 1810
- ④ FAG socket LOCKNUT-SOCKET-KM
- ⑤ Torque wrench

*Figure 5*  
Mounting tools  
for precision locknuts AM

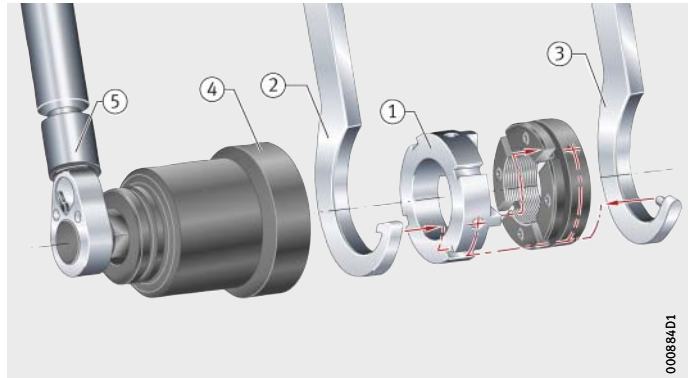



### Precision locknuts for radial locking

For tightening of locknuts ZM and ZMA, a hook wrench to DIN 1810A that engages in one of the four slots around the circumference or an FAG socket can be used, *Figure 6*.

The two grub screws are then tightened alternately to the specified tightening torque  $M_A$  using an Allen key; for  $M_A$ , see dimension tables for the bearings.

For dismounting, the two grub screws are first loosened and the locking pegs loosened by light impacts with a plastic hammer on the outside surface of the locknut (in the vicinity of the screw holes).

The locknut can then be easily unscrewed without damaging the journal thread.

- ① Hook wrench type A to DIN 1810
- ② FAG socket LOCKNUT-SOCKET-KM
- ③ Torque wrench

*Figure 6*  
Mounting tools  
for precision locknuts ZM

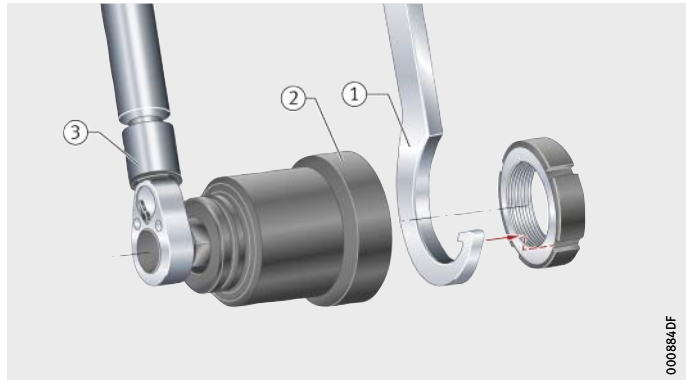

## Accessories

### FAG sockets

For simple tightening and loosening of precision locknuts ZM on shafts, the sockets LOCKNUT-SOCKET-KM, *Figure 7* are suitable. In combination with the socket AMS, this socket is also suitable for precision locknuts AM. They require less space on the circumference of the nut than hook wrenches and allow the use of ratchets and torque wrenches.

For increased reliability, FAG sockets should be secured using a locking pin and rubber washer. They therefore have a hole for the locking pin and a groove for the rubber washer. The locking pin and rubber washer are included in the scope of delivery.



*Figure 7*  
FAG socket  
for precision locknuts ZM  
and sockets AMS

**Accuracy** Accuracy of precision locknuts: see table.

**Axial runout**

Axial runout of axial face to thread <sup>1)</sup>	Metric thread in accordance with DIN 13-21 to DIN 13-24 Tolerance class
μm	Fine
5	5H

<sup>1)</sup> The axial face and thread are machined in a single clamping operation, in order to achieve very high accuracy. Before measurement, the precision locknut is clamped against a rigid shoulder on a threaded mandrel to a defined tightening torque. The grub screws remain loosened.



# Seal carrier assemblies

For ZARF, light series

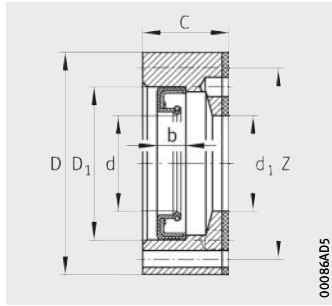

DRS<sup>1)</sup>

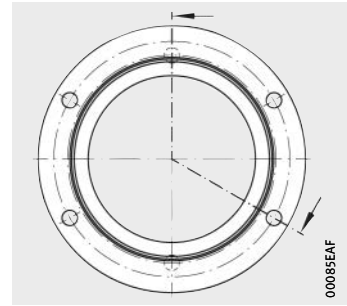

Hole pattern DRS1560, DRS1762

**Dimension table** - Dimensions in mm

Designation	Mass m  ≈ kg	Dimensions				Rotary shaft seal				Matching bearing
		D	C	d <sub>1</sub>	Z	d	D <sub>1</sub>	b	Socket head screw to DIN EN ISO 4762 each 4 piece	
<b>DRS1560</b>	0,16	60	14	35	52,4	<b>35</b>	45	7	M3×20	<b>ZARF1560(-L)-TV</b>
<b>DRS1762</b>	0,18	62	15,5	38	54,4	<b>38</b>	47	7	M3×25	<b>ZARF1762(-L)-TV</b>
<b>DRS2068</b>	0,2	68	17	42	60,4	<b>42</b>	55	8	M3×25	<b>ZARF2068(-L)-TV</b>
<b>DRS2575</b>	0,22	75	17	47	67,4	<b>47</b>	62	6	M3×25	<b>ZARF2575(-L)-TV</b>
<b>DRS3080</b>	0,26	80	17	52	73,4	<b>52</b>	68	8	M3×25	<b>ZARF3080(-L)-TV</b>
<b>DRS3590</b>	0,38	90	19	60	80	<b>60</b>	72	8	M4×25	<b>ZARF3590(-L)-TV</b>
<b>DRS40100</b>	0,47	100	19	65	90	<b>65</b>	80	8	M4×30	<b>ZARF40100(-L)-TV</b>
<b>DRS45105</b>	0,53	105	20	70	95	<b>70</b>	85	8	M4×30	<b>ZARF45105(-L)-TV</b>
<b>DRS50115</b>	0,54	115	20	78	106	<b>78</b>	100	10	M3×30	<b>ZARF50115(-L)-TV</b>

<sup>1)</sup> The seal carrier assembly is supplied as a sealing set in individual parts comprising:

- a seal carrier
- a rotary shaft seal
- a gasket
- socket head screws.

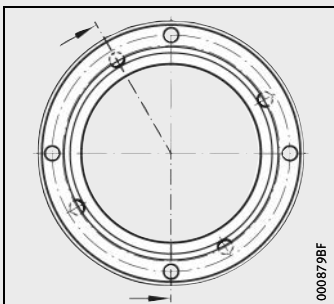

Hole pattern DRS3080, DRS3590, DRS50115

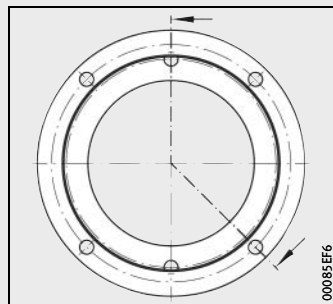

Hole pattern DRS2068, DRS2575, DRS40100, DRS45105

# Seal carrier assemblies

For ZARF, heavy series

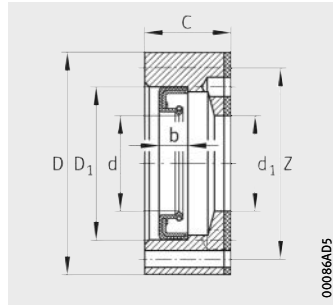

DRS<sup>1)</sup>

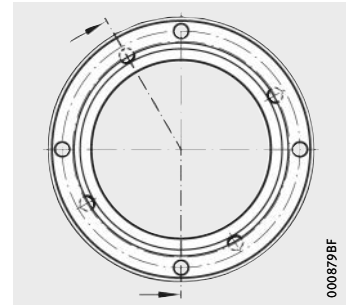

Hole pattern

**Dimension table** · Dimensions in mm

Designation	Mass m ≈ kg	Dimensions				Rotary shaft seal				Matching bearing
		D	C	d <sub>1</sub>	Z	d	D <sub>1</sub>	b	Socket head screw to DIN EN ISO 4762 each 4 piece	
<b>DRS2080</b>	0,3	80	22	52	73,4	<b>52</b>	68	8	M3×30	<b>ZARF2080(-L)-TV</b>
<b>DRS2590</b>	0,38	90	22	62	81	<b>62</b>	75	10	M3×30	<b>ZARF2590(-L)-TV</b>
<b>DRS30105</b>	0,67	105	25	68	95	<b>68</b>	85	10	M4×35	<b>ZARF30105(-L)-TV</b>
<b>DRS35110</b>	0,6	110	25	73	101	<b>73</b>	95	10	M3×30	<b>ZARF35110(-L)-TV</b>
<b>DRS40115</b>	0,7	115	27,5	78	106	<b>78</b>	100	10	M3×35	<b>ZARF40115(-L)-TV</b>
<b>DRS45130</b>	1,1	130	31	90	120	<b>90</b>	110	12	M4×40	<b>ZARF45130(-L)-TV</b>
<b>DRS50140</b>	1,4	140	30	95	127,5	<b>95</b>	115	13	M5×40	<b>ZARF50140(-L)-TV</b>
<b>DRS55145</b>	1,42	145	30	100	132,5	<b>100</b>	120	12	M5×40	<b>ZARF55145(-L)-TV</b>
<b>DRS60150</b>	1,42	150	30	105	137,5	<b>105</b>	125	12	M5×40	<b>ZARF60150(-L)-TV</b>
<b>DRS65155</b>	1,43	155	30	110	142,5	<b>110</b>	130	12	M5×40	<b>ZARF65155(-L)-TV</b>
<b>DRS70160</b>	1,5	160	30	115	147,5	<b>115</b>	135	13	M5×40	<b>ZARF70160(-L)-TV</b>
<b>DRS75185</b>	2,4	185	36	135	172,5	<b>135</b>	160	15	M5×50	<b>ZARF75185(-L)-TV</b>
<b>DRS90210</b>	2,7	210	38	160	194	<b>160</b>	180	15	M5×50	<b>ZARF90210(-L)-TV</b>

<sup>1)</sup> The seal carrier assembly is supplied as a sealing set in individual parts comprising:

- a seal carrier
- a rotary shaft seal
- a gasket
- socket head screws.



# Precision locknuts

For axial locking

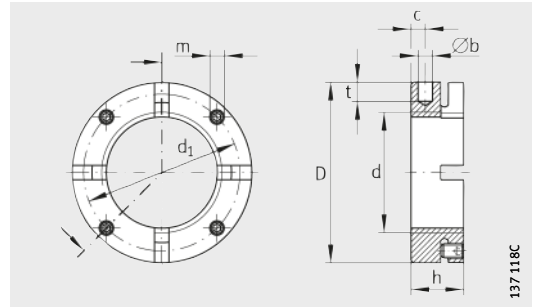

AM15 to AM40 with 4 segments  
 AM45 to AM90 with 6 segments  
 AM100 to AM130 with 8 segments

**Dimension table** - Dimensions in mm

Designation	Mass m ≈ kg	Dimensions									Grub screw Tightening torque M <sub>A</sub> Nm	Locknut <sup>1)</sup>			
		d	D	h	b H11	t	d <sub>1</sub>	c	m	Axial rupture load F <sub>aB</sub> N		Break-away torque M <sub>L</sub> at M <sub>AL</sub> Nm	Reference tightening torque Nm	Mass moment of inertia M <sub>M</sub> kg · cm <sup>2</sup>	
AM15	0,06	M15×1	30	18	4	5	24	5	M5	3	100 000	20	10	0,09	
AM17	0,07	M17×1	32	18	4	5	26	5	M5	3	120 000	25	15	0,11	
AM20	0,13	M20×1	38	18	4	6	31	5	M6	5	145 000	45	18	0,23	
AM25	0,16	M25×1,5	45	20	5	6	38	6	M6	5	205 000	60	25	0,49	
AM30	0,20	M30×1,5	52	20	5	7	45	6	M6	5	250 000	70	32	0,86	
AM30/65	0,50	M30×1,5	65	30	6	8	45	6	M6	5	400 000	70	32	2,8	
AM35/58	0,23	M35×1,5	58	20	5	7	51	6	M6	5	280 000	90	40	1,3	
AM35	0,33	M35×1,5	65	22	6	8	58	6	M6	5	330 000	100	40	2,4	
AM40	0,30	M40×1,5	65	22	6	8	58	6	M6	5	350 000	120	55	2,3	
AM40/85	0,75	M40×1,5	85	32	6	8	58	6	M6	5	570 000	120	55	7,6	
AM45	0,34	M45×1,5	70	22	6	8	63	6	M6	5	360 000	220	65	2,9	
AM50	0,43	M50×1,5	75	25	6	8	68	8	M6	5	450 000	280	85	4,3	
AM55	0,60	M55×2	85	26	6	8	75	8	M8	15	520 000	320	95	7,7	
AM60	0,65	M60×2	90	26	6	8	80	8	M8	15	550 000	365	100	9,4	
AM65	0,83	M65×2	100	26	8	10	88	8	M8	15	560 000	400	120	14,6	
AM70	0,79	M70×2	100	28	8	10	90	9	M8	15	650 000	450	130	14,7	
AM75	1,23	M75×2	115	30	8	10	102	10	M10	20	750 000	610	150	29	
AM80	0,93	M80×2	110	30	8	10	98	10	M10	20	670 000	770	160	21,3	
AM85	0,97	M85×2	115	30	8	10	102	10	M10	20	690 000	930	180	24,8	
AM90	1,53	M90×2	130	32	8	10	118	13	M10	20	900 000	1 100	200	48	
AM100	1,12	M100×2	130	30	8	10	118	10	M10	20	740 000	1 200	250	38	
AM110	1,22	M110×2	140	30	8	10	128	10	M10	20	770 000	1 300	250	48	
AM120	1,56	M120×2	155	30	8	10	142	10	M10	20	880 000	1 450	250	75	
AM130	1,67	M130×2	165	30	8	10	152	10	M10	20	900 000	1 600	250	92	

<sup>1)</sup> Attention!

If precision locknuts AM are fitted using the socket AMS, a maximum of twice the tightening torque of the bearing according to the dimension table is permissible.

# Precision locknuts

For radial locking

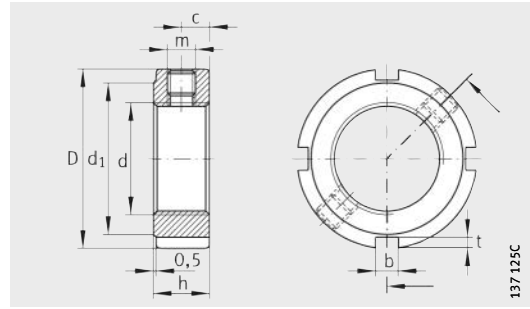

ZM, ZMA

137125C

Dimension table · Dimensions in mm

Designation	Mass m ≈ kg	Dimensions								Grub screw Tightening torque M <sub>A</sub> Nm	Locknut			
		d	D	h	b	t	d <sub>1</sub>	c	m		Axial rupture load F <sub>aB</sub> N	Break-away torque M <sub>L</sub> at M <sub>AL</sub> Nm	Reference tightening torque Nm	Mass moment of inertia M <sub>M</sub> kg · cm <sup>2</sup>
ZM06	0,01	M6×0,5	16	8	3	2	11	4	M4	1	17 000	20	2	0,004
ZM08 <sup>1)</sup>	0,01	M8×0,75	16	8	3	2	11	4	M4	1	23 000	25	4	0,004
ZM10 <sup>1)</sup>	0,01	M10×1	18	8	3	2	14	4	M4	1	31 000	30	6	0,006
ZM12	0,015	M12×1	22	8	3	2	18	4	M4	1	38 000	30	8	0,013
ZM15	0,018	M15×1	25	8	3	2	21	4	M4	1	50 000	30	10	0,021
ZMA15/33	0,08	M15×1	33	16	4	2	28	8	M5	3	106 000	30	10	0,14
ZM17	0,028	M17×1	28	10	4	2	23	5	M5	3	57 000	30	15	0,401
ZM20	0,035	M20×1	32	10	4	2	27	5	M5	3	69 000	40	18	0,068
ZMA20/38	0,12	M20×1	38	20	5	2	33	10	M5	3	174 000	40	18	0,297
ZMA20/52	0,32	M20×1	52	25	5	2	47	12,5	M5	3	218 000	40	18	1,38
ZM25	0,055	M25×1,5	38	12	5	2	33	6	M6	5	90 000	60	25	0,157
ZMA25/45	0,16	M25×1,5	45	20	5	2	40	10	M6	5	211 000	60	25	0,572
ZMA25/58	0,43	M25×1,5	58	28	6	2,5	52	14	M6	5	305 000	60	25	2,36
ZM30	0,075	M30×1,5	45	12	5	2	40	6	M6	5	112 000	70	32	0,304
ZMA30/52	0,22	M30×1,5	52	22	5	2	47	11	M6	5	270 000	70	32	1,1
ZMA30/65	0,55	M30×1,5	65	30	6	2,5	59	15	M6	5	390 000	70	32	3,94
ZM35	0,099	M35×1,5	52	12	5	2	47	6	M6	5	134 000	80	40	0,537
ZMA35/58	0,26	M35×1,5	58	22	6	2,5	52	11	M6	5	300 000	80	40	1,66
ZMA35/70	0,61	M35×1,5	70	30	6	2,5	64	15	M6	5	460 000	80	40	5,2
ZM40	0,14	M40×1,5	58	14	6	2,5	52	7	M6	5	157 000	95	55	0,945
ZMA40/62	0,27	M40×1,5	62	22	6	2,5	56	11	M8	15	310 000	95	55	2,07
ZMA40/75	0,67	M40×1,5	75	30	6	2,5	69	15	M8	15	520 000	95	55	6,72
ZM45	0,17	M45×1,5	65	14	6	2,5	59	7	M6	5	181 000	110	65	1,48
ZMA45/68	0,35	M45×1,5	68	24	6	2,5	62	12	M8	15	360 000	110	65	3,2
ZMA45/85	0,92	M45×1,5	85	32	7	3	78	16	M8	15	630 000	110	65	11,9
ZM50	0,19	M50×1,5	70	14	6	2,5	64	7	M6	5	205 000	130	85	1,92
ZMA50/75	0,43	M50×1,5	75	25	6	2,5	68	12,5	M8	15	415 000	130	85	4,89
ZMA50/92	1,06	M50×1,5	92	32	8	3,5	84	16	M8	15	680 000	130	85	16,1
ZM55	0,23	M55×2	75	16	7	3	68	8	M6	5	229 000	150	95	2,77
ZMA55/98	1,17	M55×2	98	32	8	3,5	90	16	M8	15	620 000	150	95	20,5

1) When clamped, the grub screw protrudes by ≈ 0,5 mm.



# Precision locknuts

For radial locking

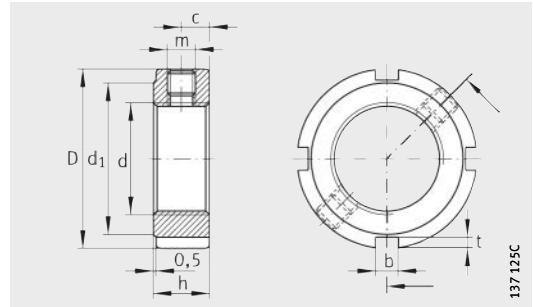

ZM, ZMA

**Dimension table** (continued) · Dimensions in mm

Designation	Mass m ≈ kg	Dimensions								Grub screw Tightening torque M <sub>A</sub> Nm	Locknut			
		d	D	h	b	t	d <sub>1</sub>	c	m		Axial rupture load F <sub>aB</sub> N	Break-away torque M <sub>L</sub> at M <sub>AL</sub> Nm	Reference tightening torque M <sub>AL</sub> Nm	Mass moment of inertia M <sub>M</sub> kg · cm <sup>2</sup>
ZM60	0,25	M60×2	80	16	7	3	73	8	M6	5	255 000	180	100	3,45
ZMA60/98	1,07	M60×2	98	32	8	3,5	90	16	M8	15	680 000	180	100	19,6
ZM65	0,27	M65×2	85	16	7	3	78	8	M6	5	280 000	200	120	4,24
ZMA65/105	1,21	M65×2	105	32	8	3,5	97	16	M8	15	750 000	200	120	25,6
ZM70	0,36	M70×2	92	18	8	3,5	85	9	M8	15	305 000	220	130	6,61
ZMA70/110	1,4	M70×2	110	35	8	3,5	102	17,5	M8	15	810 000	220	130	33
ZM75	0,4	M75×2	98	18	8	3,5	90	9	M8	15	331 000	260	150	8,41
ZMA75/125	2,11	M75×2	125	38	8	3,5	117	19	M8	15	880 000	260	150	62,2
ZM80	0,46	M80×2	105	18	8	3,5	95	9	M8	15	355 000	285	160	11,2
ZMA80/120	1,33	M80×2	120	35	8	4	105	17,5	M8	15	810 000	285	160	44,6
ZM85	0,49	M85×2	110	18	8	3,5	102	9	M8	15	385 000	320	190	13,1
ZM90	0,7	M90×2	120	20	10	4	108	10	M8	15	410 000	360	200	21,8
ZMA90/130	2,01	M90×2	130	38	10	4	120	19	M8	15	910 000	360	200	64,1
ZMA90/155	3,36	M90×2	155	38	10	4	146	19	M8	15	1 080 000	360	200	150
ZM100	0,77	M100×2	130	20	10	4	120	10	M8	15	465 000	425	250	28,6
ZMA100/140	2,23	M100×2	140	38	12	5	128	19	M10	20	940 000	425	250	82,8
ZM105	1,05	M105×2	140	22	12	5	126	11	M10	20	495 000	475	300	44,5
ZM110	1,09	M110×2	145	22	12	5	133	11	M10	20	520 000	510	350	50,1
ZM115	1,13	M115×2	150	22	12	5	137	11	M10	20	550 000	550	400	56,2
ZM120	1,28	M120×2	155	24	12	5	138	12	M10	20	580 000	600	450	68,4
ZM125	1,33	M125×2	160	24	12	5	148	12	M10	20	610 000	640	500	76,1
ZM130	1,36	M130×2	165	24	12	5	149	12	M10	20	630 000	700	550	84,3
ZM140	1,85	M140×2	180	26	14	6	160	13	M12	38	690 000	800	600	133
ZM150	2,24	M150×2	195	26	14	6	171	13	M12	38	750 000	900	650	188



# Sockets

For precision locknuts  
suitable for axial locking

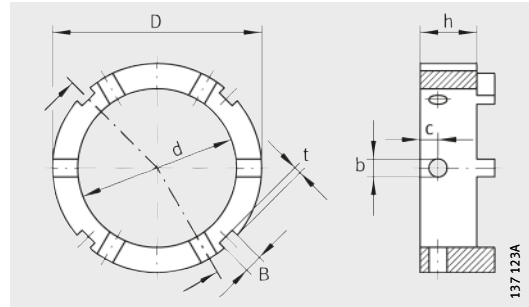

AMS

**Dimension table** · Dimensions in mm

Designation	Mass m ≈ kg	Dimensions							For precision locknuts
		d	D	h	b H11	c	B	t	
<b>AMS20</b>	0,047	<b>22</b>	32	14	4	5	4	2	<b>AM15, AM17, AM20</b>
<b>AMS30</b>	0,093	<b>35</b>	45	15	5	5	5	2	<b>AM25, AM30, AM35/58, AM30/65</b>
<b>AMS40</b>	0,217	<b>45</b>	65	16	6	6	6	2,5	<b>AM35, AM40</b>
<b>AMS50</b>	0,245	<b>53</b>	70	19	6	6	6	2,5	<b>AM45, AM50</b>
<b>AMS60</b>	0,37	<b>65</b>	85	20	6	6	7	3	<b>AM55, AM60</b>
<b>AMS70</b>	0,615	<b>75</b>	98	25	8	10	8	3,5	<b>AM65, AM70</b>
<b>AMS80</b>	0,755	<b>85</b>	110	25	8	10	8	3,5	<b>AM75, AM80, AM85</b>
<b>AMS90</b>	1,215	<b>95</b>	130	25	8	10	10	4	<b>AM90</b>
<b>AMS110</b>	0,74	<b>110</b>	130	25	8	10	10	4	<b>AM100, AM110</b>
<b>AMS130</b>	1,485	<b>130</b>	155	25	8	10	12	5	<b>AM120, AM130</b>



# Sockets

For precision locknuts  
 suitable for radial or axial locking  
 For torque wrench  
 Suitable for combination with sockets AMS

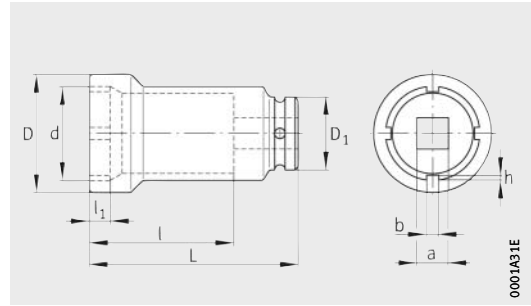

LOCKNUT-SOCKET-KM

Dimension table - Dimensions in mm										
Designation	Mass ≈ kg	Dimensions						Suitable for		Suitable in combination with AMS for AM
		d	D	D <sub>1</sub>	L	l	a <i>inch</i>	Precision locknut	Socket	
								ZM	AMS	
LOCKNUT-SOCKET-KM0	0,1	18,1	22	22	57	44	3/8	ZM10	-	-
LOCKNUT-SOCKET-KM1	0,1	22,2	28	22	57	44	3/8	ZM12	-	-
LOCKNUT-SOCKET-KM2	0,2	25,2	33	30	82	60	1/2	ZM15	-	-
LOCKNUT-SOCKET-KM3	0,24	28,2	36	30	82	60	1/2	-	AMS20	AM15 AM17 AM20
								ZM17		
								-		
LOCKNUT-SOCKET-KM4	0,28	32,2	38	30	82	56	1/2	ZM20	-	-
LOCKNUT-SOCKET-KM5	0,38	38,2	46	30	82	56	1/2	ZMA20/38	-	-
								ZM25		
LOCKNUT-SOCKET-KM6	0,42	45,2	53	30	82	56	1/2	ZMA25/45	AMS30	AM25 AM30 AM35/58 AM30/65
								ZM30		
								-		
								-		
LOCKNUT-SOCKET-KM7	0,45	52,2	60	30	82	56	1/2	ZMA20/52	-	-
								ZMA30/52		
								ZM35		
LOCKNUT-SOCKET-KM8	0,61	58,3	68	30	82	56	1/2	ZMA25/58	-	-
								ZMA35/58		
								ZM40		
LOCKNUT-SOCKET-KM9	0,8	65,4	73,5	44	90	62	3/4	ZMA30/65	AMS40	AM35 AM40
								-		
								-		
								ZM45		
LOCKNUT-SOCKET-KM10	0,85	70,4	78,5	44	90	62	3/4	ZMA35/70	AMS50	AM45 AM50
								-		
								ZM50		
LOCKNUT-SOCKET-KM11	0,9	75,4	83,5	44	90	62	3/4	ZMA40/75	-	-
								ZMA50/75		
								ZM55		

# Sockets

For precision locknuts  
 suitable for radial or axial locking  
 For torque wrench  
 Suitable for combination with sockets AMS

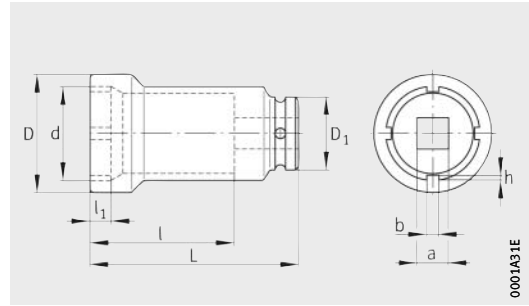

LOCKNUT-SOCKET-KM

Dimension table (continued) - Dimensions in mm										
Designation	Mass ≈ kg	Dimensions						Suitable for		Suitable in combination with AMS for AM
		d	D	D <sub>1</sub>	L	l	a <i>inch</i>	Precision locknut ZM	Socket AMS	
LOCKNUT-SOCKET-KM13	1,1	85,6	94	44	90	60	3/4	ZMA45/85	–	–
								–	AMS60	AM55
								–	–	AM60
LOCKNUT-SOCKET-KM14	2,2	92,5	103	76	110	74	1	ZMA50/92	–	–
								ZM70	–	–
LOCKNUT-SOCKET-KM15	2,3	98,5	109	76	110	74	1	ZMA55/98	–	–
								ZMA60/98	–	–
								–	AMS70	AM65
								–	–	AM70
LOCKNUT-SOCKET-KM16	2,45	105,6	116	76	110	74	1	ZMA65/105	–	–
								ZM80	–	–
LOCKNUT-SOCKET-KM17	2,6	110,6	121	76	110	74	1	ZMA70/110	–	–
								–	AMS80	AM75
								–	–	AM80
								ZM85	–	AM85
LOCKNUT-SOCKET-KM18	2,9	120,6	131	76	110	74	1	ZMA80/120	–	–
								ZM90	–	–
LOCKNUT-SOCKET-KM19	3,05	125,6	137	76	110	74	1	ZMA75/125	–	–
LOCKNUT-SOCKET-KM20	3,3	130,6	143	76	110	74	1	ZMA90/130	AMS90	AM90
								ZM100	AMS110	AM100
								–	–	AM110
LOCKNUT-SOCKET-KM21	3,43	115	153	76	110	80	1	ZMA100/140	–	–
								ZM105	–	–
LOCKNUT-SOCKET-KM22	3,54	120	158	76	110	80	1	ZM110	–	–
LOCKNUT-SOCKET-KM24	4,15	130	170	76	110	80	1	ZMA90/155	–	–
								ZM120	AMS130	AM120
								–	–	AM130



# BEARINX-online Easy BallScrew

## Calculation of screw drive bearing arrangements

In order to ensure the correct use of products, Schaeffler offers the necessary support in partnership with the customer, from the very first design idea to delivery of the products. A key aspect of design advisory work is the selection and design of rolling bearings. The optimum selection and design of products gives Schaeffler customers a competitive advantage. To this end, Schaeffler has been successfully using calculation programs for many years.

### BEARINX-online

Through the use of BEARINX, specific bearing loads can be calculated in detail, represented and documented taking account of operating and environmental conditions. The contact pressure on each individual rolling element is included in the calculation process.

BEARINX takes account of factors including the following:

- the non-linear elastic deflection behaviour of rolling elements
- elasticity of the bearing rings
- displacements in contact angle induced by load
- the actual contact pressure taking account of the misalignment and profiling of rolling elements.

### Module Easy BallScrew

For the calculation of screw drive bearing arrangements, there is a separate BEARINX-online module which can be used to calculate the most commonly used arrangements of bearings, *Figure 1*.

In addition to the existing BEARINX-online software, the new module Easy BallScrew fits logically into the proven range of Easy calculation programs.

With Easy BallScrew, it is possible to calculate the minimum static load safety factor and the adjusted reference rating life for all arrangements of bearings. For locating/locating bearing arrangements, the spindle tensioning force and the value for effective spindle elongation due to tensioning as well as all adjustment values for mounting are also outputted.

Easy BallScrew has access to the Schaeffler bearing database. Axial angular contact ball bearings and needle roller/axial cylindrical roller bearings as well as other screw drive bearings can be easily integrated.



*Figure 1*  
BEARINX-online,  
module Easy BallScrew

Influencing factors typical for the application

The following influencing factors typical for the application are taken into consideration:

- location of the bearing on the shaft
- consideration of shaft material
- consideration of bearing set combinations
- operating temperature range
- lubrication and severity of contamination.

## User-friendly interface

The program provides four common arrangements of bearings for screw drives as preconfigured calculation models, *Figure 2*:

- locating bearing arrangement on one side
- locating/non-locating bearing arrangement
- locating/locating bearing arrangement (spindle tensioning by locknut)
- locating/locating bearing arrangement (spindle tensioning by shim).

All the necessary operating data can be inputted separately, with navigation by means of user-friendly menus:

- arrangement of bearings
- bearing selection
- load case data
- lubrication.

Data can be inputted quickly and easily thanks to the self-explanatory menu navigation, *Figure 3*, page 156. The geometrical data of INA and FAG rolling bearings are easily loaded from an integrated database. Operating conditions are inputted in the form of a duty cycle in a table, *Figure 4*, page 156.

- ① Locating bearing arrangement, one side
- ② Locating/non-locating bearing arrangement
- ③ Locating/locating bearing arrangement (spindle tensioning by locknut)
- ④ Locating/locating bearing arrangement (spindle tensioning by shim)

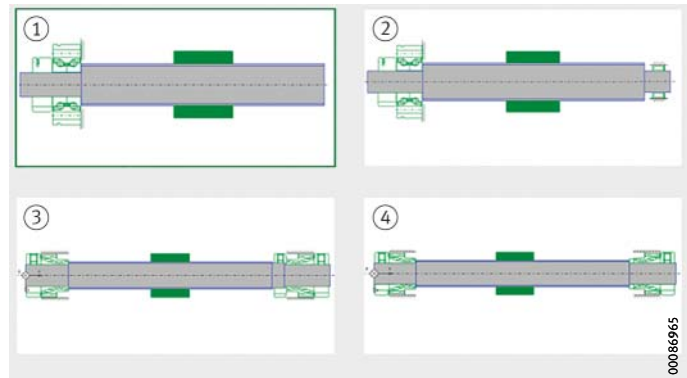

*Figure 2*  
Preconfigured calculation models



# BEARINX-online Easy BallScrew

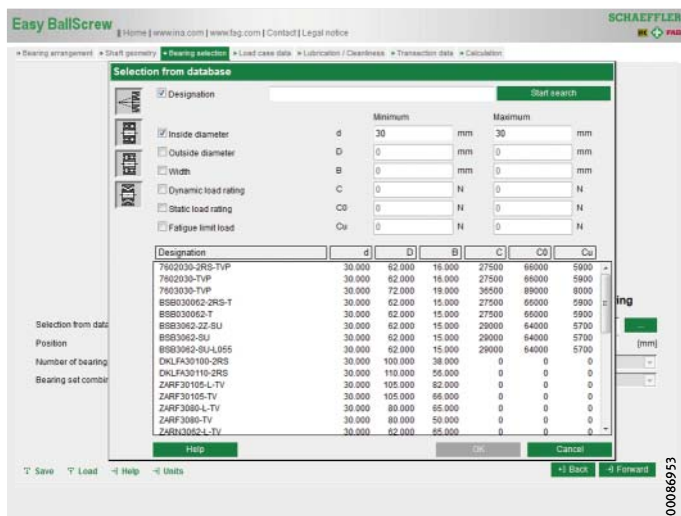

Figure 3  
Bearing selection from database

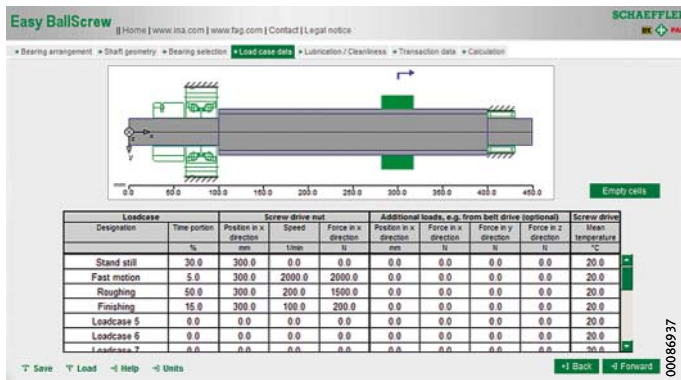

Figure 4  
Input of speed/load cycle

## Data interchange with Schaeffler

All input data can be stored. As a result, relevant modifications can be quickly made to an existing application case without the need for duplicated input of data. Furthermore, the stored file can be exchanged with the Schaeffler engineering service in order to achieve an optimum bearing design.

The BEARINX-online modules run on the powerful calculation servers at Schaeffler. Once calculation has been successfully carried out, the most significant calculation results are displayed. In addition, a comprehensive results view can be called up.

Registration for the calculation program

<http://bearinx-online-easy-ballscrew.schaeffler.com>



The module BEARINX-online Easy BallScrew is available only in an online format and can be used free of charge.

Initial registration takes only a short time and you can then start your calculation work straight away.

# Addresses

## Worldwide

You can find all the addresses and contacts for Schaeffler at [www.schaeffler.com](http://www.schaeffler.com)

## Argentina

Schaeffler Argentina S.r.l.  
Av. Alvarez Jonte 1938  
C1416EXR Buenos Aires  
Tel. +(54) 11 / 40 16 15 00  
Fax +(54) 11 / 45 82 33 20  
[info-ar@schaeffler.com](mailto:info-ar@schaeffler.com)

## Armenia

Schaeffler Ukraine GmbH  
Zhylyanskaya Str. 75, 5. Stock,  
Businesscenter «Eurasia»  
01032 Kiev  
Ukraine  
Tel. +(380) 44 520 13 80  
Fax +(380) 44 520 13 81  
[info.ua@schaeffler.com](mailto:info.ua@schaeffler.com)

## Australia

Schaeffler Australia Pty Ltd  
Level 1, Bldg 8, Forest Central  
Business Park  
49 Frenchs Forest Road  
Frenchs Forst, NSW 2086  
Tel. +(61) 2 8977 1000  
Fax +(61) 2 9452 4242  
[sales.au@schaeffler.com](mailto:sales.au@schaeffler.com)

Schaeffler Australia Pty Limited  
Suite 14, Level 3  
74 Doncaster Road  
North Balwyn, VIC 3104  
Tel. +(61) 3 9859 8020  
Fax +(61) 3 9859 8767  
[milos.grujic@schaeffler.com](mailto:milos.grujic@schaeffler.com)

Schaeffler Australia Pty Ltd  
Unit 3, 47 Steel Place  
Morningside, QLD 4170  
Tel. +(61) 7 3399 9161  
Fax +(61) 7 3399 9351  
[martin.grosvenor@schaeffler.com](mailto:martin.grosvenor@schaeffler.com)

## Austria

Schaeffler Austria GmbH  
Ferdinand-Pözl-Straße 2  
2560 Berndorf-St. Veit  
Tel. +(43) 2672 202-0  
Fax +(43) 2672 202-1003  
[info.at@schaeffler.com](mailto:info.at@schaeffler.com)

## Belarus

Schaeffler Technologies AG & Co. KG  
Repräsentanz Weißrussland  
Odoewskogo 117, office 317  
220015 Minsk  
Tel. +(375) 17 336 94 81  
Fax +(375) 17 336 94 82  
[info.by@schaeffler.com](mailto:info.by@schaeffler.com)

## Belgium

Schaeffler Belgium S.P.R.L./B.V.B.A.  
Avenue du Commerce, 38  
1420 Braine L'Alleud  
Tel. +(32) 2 3 89 13 89  
Fax +(32) 2 3 89 13 99  
[info.be@schaeffler.com](mailto:info.be@schaeffler.com)

## Bolivia

Schaeffler Chile Ltda.  
Jose Tomas Rider 1051  
Providencia  
7501037 Santiago  
Chile  
Tel. +(56) 2 477 5000  
Fax +(56) 2 2223 9941  
[info-cl@schaeffler.com](mailto:info-cl@schaeffler.com)

## Bosnia-Herzegovina

Schaeffler Hrvatska d.o.o.  
Ogrizovićeva 28b  
10000 Zagreb  
Croatia  
Tel. +(385) 1 37 01 943  
Fax +(385) 1 37 64 473  
[info.hr@schaeffler.com](mailto:info.hr@schaeffler.com)

## Brazil

Schaeffler Brasil Ltda.  
Av. Independência, 3500-A  
Bairro Eden  
18087-101 Sorocaba, SP  
Tel. +(55) 15 3335 1422  
Tel. 0800 11 10 29  
Fax +(55) 1533 35 19 60  
[sac.br@schaeffler.com](mailto:sac.br@schaeffler.com)

## Bulgaria

Schaeffler Bulgaria OOD  
Dondukov-Bldv. No 62  
Eing. A, 6. Etage, App. 10  
1504 Sofia  
Tel. +(359) 2 946 3900  
+(359) 2 943 4008  
Fax +(359) 2 943 4134  
[info.bg@schaeffler.com](mailto:info.bg@schaeffler.com)

## Canada

Schaeffler Canada Inc.  
100 Alexis Nihon Suite 390  
Montréal, QC H4M 2N8  
Tel. +(1) 514-748-5111  
Tel. 800-361-5841 Toll Free  
Fax +(1) 514-748-6111  
[info.ca@schaeffler.com](mailto:info.ca@schaeffler.com)

Schaeffler Canada Inc.  
2871 Plymouth Drive  
Oakville, ON L6H 5S5  
Tel. +(1) 905-829-2750  
Tel. 800-263-4397 Toll Free  
Fax +(1) 905-829-2563  
[info.ca@schaeffler.com](mailto:info.ca@schaeffler.com)

Schaeffler Canada Inc.  
#106, 7611 Sparrow Drive  
Leduc, AB T9E 0H3  
Tel. +(1) 780-980-3016  
Tel. 800-663-9006 Toll Free  
Fax +(1) 780-980-3037  
[info.ca@schaeffler.com](mailto:info.ca@schaeffler.com)

## Chile

Schaeffler Chile Ltda.  
Jose Tomas Rider 1051  
Providencia  
7501037 Santiago  
Chile  
Tel. +(56) 2 477 5000  
Fax +(56) 2 2223 9941  
[info-cl@schaeffler.com](mailto:info-cl@schaeffler.com)

## China

Schaeffler Holding (China) Co., Ltd.  
No. 1 Antuo Road  
(west side of Anhong Road)  
AnTing, JiaDing District  
201804 Shanghai  
Tel. +(86) 21 3957 6666  
Fax +(86) 21 3957 6600  
[info\\_china@schaeffler.com](mailto:info_china@schaeffler.com)

## Colombia

Schaeffler Colômbia Ltda.  
Cra. 10 Nº 97A 13 Torre A  
Ofic 209 Bogotá Trade Center  
Bogotá  
Tel. +(57) 1 621 53 00  
Fax +(57) 1 621 03 22  
[info-co@schaeffler.com](mailto:info-co@schaeffler.com)

# Addresses

## Croatia

Schaeffler Hrvatska d.o.o.  
Ogrizovićeva 28b  
10000 Zagreb  
Tel. +(385) 1 37 01 943  
Fax +(385) 1 37 64 473  
info.hr@schaeffler.com

## Czech Republic

Schaeffler CZ s.r.o.  
Průběžná 74a  
100 00 Praha 10  
Tel. +(420) 267 298 111  
Fax +(420) 267 298 110  
info.cz@schaeffler.com

## Denmark

Schaeffler Danmark ApS  
Jens Baggesens Vej 90P  
8200 Aarhus N  
Tel. +(45) 70 15 44 44  
Fax +(45) 70 15 22 02  
info.dk@schaeffler.com

## Egypt

Delegation Office  
Schaeffler Technologies  
25, El Obour Buildings – Floor 18 – Flat 4  
Salah Salem St.  
11371 Cairo  
Tel. +(20) 2 24012432  
Fax +(20) 2 22612637  
schaeffleregypt@schaeffleregypt.com

## Estonia

Schaeffler Technologies  
Repräsentanz Baltikum  
Duntes iela 23a  
1005 Riga  
Latvia  
Tel. +(371) 67 06 37 95  
Fax +(371) 67 06 37 96  
info.lv@schaeffler.com

## Finland

Schaeffler Finland Oy  
Lautamiehentie 3  
02770 Espoo  
Tel. +(358) 207 36 6204  
Fax +(358) 207 36 6205  
info.fi@schaeffler.com

## France

Schaeffler France SAS  
93, route de Bitche, BP 30186  
67506 Haguenau  
Tel. +(33) 3 88 63 40 40  
Fax +(33) 3 88 63 40 41  
info.fr@schaeffler.com

## Germany

Schaeffler Technologies AG & Co. KG  
Industriestraße 1 – 3  
91074 Herzogenaurach  
Tel. +(49) 9132 82-0  
Fax +(49) 9132 82-4950  
info.de@schaeffler.com

Schaeffler Technologies AG & Co. KG  
Georg-Schäfer-Str. 30  
97421 Schweinfurt  
Tel. +(49) (9721) 91-0  
Fax +(49) (9721) 91-3435  
faginfo@schaeffler.com

FAG Aerospace GmbH & Co. KG  
Georg-Schäfer-Str. 30  
97421 Schweinfurt  
Tel. +49 (0 97 21) 91-33 72  
astrid.hofmann@schaeffler.com

## Hungary

Schaeffler Magyarország Ipari Kft.  
Rétköz u.5  
1118 Budapest  
Tel. +(36) 1 4 81 30 50  
Fax +(36) 1 4 81 30 53  
budapest@schaeffler.com

## India

FAG Bearings India Limited  
Maneja  
Vadodara 390 013  
Tel. +(91) 26 52 6426-51  
Fax +(91) 26 52 6388-04/-10  
info.fag.in@schaeffler.com

## Italy

Schaeffler Italia S.r.l.  
Via Dr. Georg Schaeffler, 7  
28015 Momo (Novara)  
Tel. +(39) 3 21 92 92 11  
Fax +(39) 3 21 92 93 00  
info.it@schaeffler.com

## Japan

Schaeffler Japan Co., Ltd.  
Schaeffler R&D Center Building,  
Yokohama Business Park,  
134 Godo-cho, Hodogaya-ku,  
240-0005 Yokohama  
Tel. +(81) 45 287 9001  
Fax +(81) 45 287 9011  
info-japan@schaeffler.com

## Korea

Schaeffler Korea Corporation –  
Guro Office  
A-501, 1258, Guro-dong, Guro-gu,  
Seoul, 152-721  
Tel. +(82) 2 2625-8572  
Fax +(82) 2 2611-6075

## Latvia

Schaeffler Technologies  
Repräsentanz Baltikum  
Duntes iela 23a  
1005 Riga  
Tel. +(371) 7 06 37 95  
Fax +(371) 7 06 37 96  
info.lv@schaeffler.com

## Lithuania

Schaeffler Technologies  
Repräsentanz Baltikum  
Duntes iela 23a  
1005 Riga  
Latvia  
Tel. +(371) 7 06 37 95  
Fax +(371) 7 06 37 96  
info.lv@schaeffler.com

## Luxembourg

Schaeffler Belgium S.P.R.L./B.V.B.A.  
Avenue du Commerce, 38  
1420 Braine L'Alleud  
Belgium  
Tel. +(32) 2 3 89 13 89  
Fax +(32) 2 3 89 13 99  
info.be@schaeffler.com

## Malaysia

Schaeffler Bearings (Malaysia) Sdn. Bhd.  
5-2 Wisma Fiamma, No. 20 Jalan 7A/62A  
Bandar Menjalara  
52200 Kuala Lumpur  
Tel. +(60) 3-6275 0620  
Fax +(60) 3 6275 6421  
marketing\_my@schaeffler.com

Schaeffler Bearings (Malaysia) Sdn. Bhd.  
(Penang Branch)  
No. B-02-28, 2nd Floor, Krystal Point  
303, Jalan Sultan Azlan Shah  
11900 Sungai Nibong  
Tel. +(60) 4 642 3708/3781  
Fax +(60) 4 642 3724

## Mexico

INA México, S.A. de C.V. -  
Rodamientos FAG, S.A. de C.V.  
Henry Ford #141  
Col. Bondonjito  
Deleg. Gustavo A. Madero  
07850 Mexico D.F.  
Tel. +(52) 55 5062 6085  
Fax +(52) 55 5739 5850  
distr.indl.mx@schaeffler.com



## Netherlands

Schaeffler Nederland B.V.  
Gildeweg 31  
3771 NB Barneveld  
Tel. +(31) 342 40 30 00  
Fax +(31) 342 40 32 80  
info.nl@schaeffler.com

## New Zealand

Schaeffler New Zealand  
(Unit R, Cain Commercial Centre)  
20 Cain Road  
1135 Penrose  
Tel. +(64) 9 583 1280  
Fax +(64) 9 583 1288  
sales.nz@schaeffler.com

## Norway

Schaeffler Norge AS  
Grønseveien 107B  
0663 Oslo  
Tel. +(47) 23 24 93 30  
Fax +(47) 23 24 93 31  
info.no@schaeffler.com

## Philippines

Schaeffler Philippines Inc  
5th Floor, Optima Building  
221 Saicedo Street, Legaspi Village  
1229 Makati City  
Tel. +(63) 2 759 3583  
Fax +(63) 2 779 8703  
marketing\_ph@schaeffler.com

## Poland

Schaeffler Polska Sp. z o.o.  
Budynek E  
ul. Szyszkowa 35/37  
02-285 Warszawa  
Tel. +(48) 22 8 78 41 20  
Fax +(48) 22 8 78 41 22  
info.pl@schaeffler.com

## Portugal

INA Rolamentos Lda.  
Arrábida Lake Towers  
Rua Daciano Baptista Marques Torre C,  
181, 2º piso  
4400-617 Vila Nova de Gaia  
Tel. +(351) 22 5 32 08 00  
Fax +(351) 22 5 32 08 60  
info.pt@schaeffler.com

Schaeffler Portugal S.A.  
Rua Estrada do Lavradio 25  
2500-294 Caldas da Rainha  
Tel. +(351) 262 837000  
Fax +(351) 262 837011

## Romania

S.C. Schaeffler Romania S.R.L.  
Aleea Schaeffler Nr. 3  
507055 Cristian/Brasov  
Tel. +(40) 268 504816  
Fax +(40) 268 505848  
info.ro@schaeffler.com

## Russia

Schaeffler Russland GmbH  
Leningradsky Prospekt 47, Bau 3  
Business-Center Avion  
125167 Moscow  
Tel. +(7) 495 7 37 76 60  
Fax +(7) 495 7 37 76 61  
info.ru@schaeffler.com

## Saudi Arabia

Schaeffler Middle East FZE  
Road SE101, Schaeffler Building  
Jebel Ali Free Zone – Southside  
Postbox 261808  
Dubai UAE  
United Arab Emirates  
Tel. +(971) 4 81 44 500  
Fax +(971) 4 81 44 601  
info.ae@schaeffler.com

## Serbia

Schaeffler Technologies  
Repräsentanz Serbien  
Branka Krsmanovica 12  
11118 Beograd  
Tel. +(381) 11 308 87 82  
Fax +(381) 11 308 87 75  
fagbgdyu@orion.rs

## Singapore

Schaeffler (Singapore) Pte. Ltd.  
151 Lorong Chuan, #06-01  
New Tech Park, Lobby A  
556741 Singapore  
Tel. +(65) 6540 8600  
Fax +(65) 6540 8668  
info.sg@schaeffler.com

## Slovak Republic

Schaeffler Slovensko, spol. s r.o.  
Ulica Dr. G. Schaefflera 1  
02401 Kysucké Nové Mesto  
Tel. +(421) 41 4 20 51 11  
Fax +(421) 41 4 20 59 18  
info.sk@schaeffler.com

Schaeffler Slovensko, spol. s r.o.  
Nevádzova 5  
821 01 Bratislava  
Tel. +(421) 2 43 294 260  
Fax +(421) 2 48 287 820  
info.sk@schaeffler.com

## Slovenia

Schaeffler Slovenija d.o.o.  
Glavni trg 17/b  
2000 Maribor  
Tel. +(386) 2 22 82 070  
Fax +(386) 2 22 82 075  
info@schaeffler.si

## South Africa

Schaeffler South Africa (Pty.) Ltd.  
1 End Street Ext. Corner Heidelberg Road  
2000 Johannesburg  
Tel. +(27) 11 225 3000  
Fax +(27) 11 334 1755  
info.co.za@schaeffler.com

## Spain

Schaeffler Iberia, S.L.U. –  
División Industria  
C/ Foment, 2  
Polígono Ind. Pont Reixat  
08960 Sant Just Desvern – Barcelona  
Tel. +(34) 93 4 80 34 10  
Fax +(34) 93 3 72 92 50  
info.es@schaeffler.com

## Sweden

Schaeffler Sverige AB  
Charles gata 10  
195 61 Arlandastad  
Tel. +(46) 8 59 51 09 00  
Fax +(46) 8 59 51 09 60  
info.se@schaeffler.com

## Switzerland

HYDREL GmbH  
Badstrasse 14  
8590 Romanshorn  
Tel. +(41) 71 4 66 66 66  
Fax +(41) 71 4 66 63 33  
info.ch@schaeffler.com

## Taiwan

Schaeffler Taiwan Co. Ltd.  
23F, No.76, Sec. 2, Dunhua S. Rd.,  
Da'an Dist.  
Taipei 106  
Tel. +886 2 7730 1911  
Fax +886 2 2707 9964  
info.tw@schaeffler.com

## Thailand

Schaeffler (Thailand) Co., Ltd.  
388 Exchange Tower 31st, 34th Floor,  
Unit 3103, 3403-3404 Sukhumvit Rd.,  
Klongtoey  
Bangkok, 10110  
Tel. +(66) 2697 0000  
Fax +(66) 2697 0001  
info.th@schaeffler.com

# Addresses

## Turkey

Schaeffler Rulmanlari Ticaret Limited  
Sirketi  
Ömer Faik Atakan cad. Saray Mah. Yılmaz  
Plaza No:3  
34768 Istanbul  
Tel. +(90) 212 2 79 27 41  
Fax +(90) 212 2 81 66 45  
info.tr@schaeffler.com

## Ukraine

Schaeffler Ukraine GmbH  
Zhylyanskaya Str. 75, 5. Stock,  
Businesscenter «Eurasia»  
01032 Kiev  
Ukraine  
Tel. +(380) 44 520 13 80  
Fax +(380) 44 520 13 81  
info.ua@schaeffler.com

## United Kingdom

Schaeffler (UK) Ltd  
Forge Lane, Minworth  
Sutton Coldfield B76 1AP  
Tel. +(44) 121 3 13 58 70  
Fax +(44) 121 3 13 00 80  
info.uk@schaeffler.com

The Barden Corporation (UK) Limited  
Plymbridge Road, Estover  
Plymouth, PL6 7LH  
Tel. +(44) 1752 73 55 55  
Fax +(44) 1752 73 34 81  
bardenbearings@schaeffler.com

## United Arab Emirates

Schaeffler Middle East FZE  
Road SE101, Schaeffler Building  
Jebel Ali Free Zone - Southside  
Postbox 261808  
Dubai UAE  
Tel. +971 4 81 44 500  
Fax +971 4 81 44 601  
info.ae@schaeffler.com

## USA

Schaeffler Group USA Inc.  
200 Park Avenue  
P.O. Box 1933  
Danbury, CT 06813-1933  
Tel. +(1) 203 790 5474  
Fax +(1) 203 830 8171  
Walter.Newton@schaeffler.com

The Barden Corporation  
200 Park Avenue  
P.O. Box 2449  
Danbury, CT 06813-2449  
Tel. +(1) 203 744 2211  
Fax +(1) 203 744 3756  
sales@bardenbearings.com

Schaeffler Group USA Inc.  
308 Springhill Farm Road  
Corporate Offices  
Fort Mill, SC 29715  
Tel. +(1) 803 548 8500  
Fax +(1) 803 548 8599  
info.us@schaeffler.com

Schaeffler Group USA Inc.  
5370 Wegman Drive  
Valley City, OH 44280-9700  
Tel. +(1) 800 274 5001  
Fax +(1) 330 273 3522  
luk-ina-fag-as.us@schaeffler.com

## Venezuela

Schaeffler Venezuela C.A.  
Urbanización San José de Tarbes  
Torre BOD, Piso 14, Oficina 14-1  
Valencia  
Tel. +(58) 58 241 825 9250  
Fax +(58) 58 241 825 9705  
ana.acevedo@schaeffler.com

## Vietnam

Schaeffler Vietnam Co., Ltd –  
Ho Chi Minh Sales Office  
6th Floor, TMS Building,  
172 Hai Ba Trung street, Da Kao Ward,  
District 1.  
Ho Chi Minh City  
Tel. +(84) 8 22 20 2777  
Fax +(84) 8 22 20 2776  
marketing\_vn@schaeffler.com

Schaeffler Vietnam Co., Ltd –  
Hanoi Sales Office  
MIPEC Tower, 12th Floor No. 229  
Tay Son Street, Dong Da District  
Ha Noi  
Tel. +(84) 4 3556 0930  
Fax +(84) 4 3556 0931  
marketing\_vn@schaeffler.com





**Schaeffler Technologies  
AG & Co. KG**

Industriestraße 1 – 3  
91074 Herzogenaurach  
Germany  
Internet [www.ina.com](http://www.ina.com)  
E-mail [info.de@schaeffler.com](mailto:info.de@schaeffler.com)

In Germany:

Phone 0180 5003872  
Fax 0180 5003873

From other countries:

Phone +49 9132 82-0  
Fax +49 9132 82-4950



**Schaeffler Technologies  
AG & Co. KG**

Georg-Schäfer-Straße 30  
97421 Schweinfurt  
Germany  
Internet [www.fag.com](http://www.fag.com)  
E-mail [faginfo@schaeffler.com](mailto:faginfo@schaeffler.com)

In Germany:

Phone 0180 5003872  
Fax 0180 5003873

From other countries:

Phone +49 9721 91-0  
Fax +49 9721 91-3435



Every care has been taken to ensure the correctness of the information contained in this publication but no liability can be accepted for any errors or omissions. We reserve the right to make technical changes.

© Schaeffler Technologies AG & Co. KG  
Issued: 2015, September

This publication or parts thereof may not be reproduced without our permission.