



FAG



Mounting and Maintenance of Rolling Bearings

Products
Services
Training

SCHAEFFLER

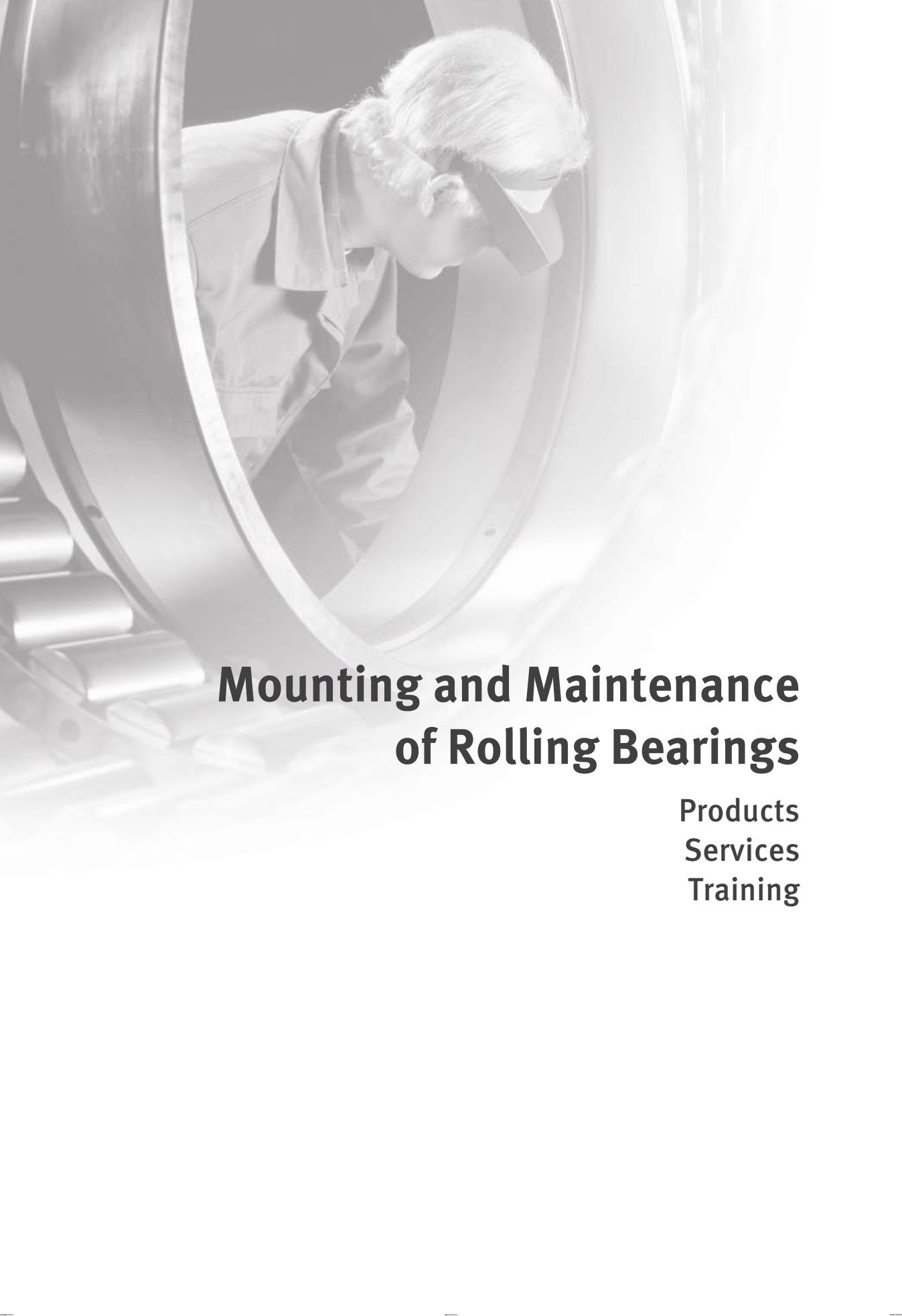

Mounting and Maintenance of Rolling Bearings

**Products
Services
Training**

All data have been prepared with a great deal of care and checked for their accuracy. However, no liability can be assumed for any incorrect or incomplete data. We reserve the right to make technical modifications.

© Schaeffler Technologies AG & Co. KG

Issued: 2015, July

Reproduction in whole or in part without our authorisation is prohibited.

Foreword

Industrial Service

This catalogue is aimed principally at maintenance managers and operators of plant in which rolling bearings and other rotating machine components play a critical role in determining the quality of products and processes. Those responsible for maintenance and production processes must be able to rely every day on the quality of their tools and the expertise of their service providers.

Within its Industrial Service concept, Schaeffler therefore offers high quality products, services and training, *Figure 1*.

Portfolio

This catalogue gives an overview of the portfolio:

- Mechanical maintenance
- Lubrication
- Condition monitoring
- Reconditioning.

The employees of Schaeffler worldwide will be pleased to help you select the ideal products, services and training courses, *Figure 1*.



Figure 1
Portfolio

Foreword

Industrial Aftermarket

Schaeffler Industrial Aftermarket (IAM) is responsible for replacement parts and service business for end customers and sales partners in all significant industrial sectors. On the basis of innovative solutions, products and services relating to rolling and plain bearings, the service function of Schaeffler Industrial Aftermarket offers a comprehensive portfolio that covers all phases in the lifecycle of the rolling bearing and takes account of the total costs (TCO).

The aim is to help customers save on maintenance costs, optimise plant availability and avoid unforeseen machine downtime. Schaeffler Industrial Aftermarket offers each customer an individual concept solution.

Schaeffler has centres of competence all around the world. This means we can provide customers worldwide with products, services and training quickly and professionally. All service employees undergo a comprehensive training programme and are audited regularly by officially certified specialists. This ensures that services throughout the world conform to a uniformly high standard of quality.

The quality requirements are strongly influenced by a long history of high precision rolling bearing manufacture. The production and provision of products and all services in this catalogue is proven in practice and is secured by a quality management system certified to ISO 9001:2008.

Sales partners

In order to achieve this objective, we have created a network of Schaeffler sales partners. This network makes it possible to support all end customers worldwide with the same high level of expertise and is thus the optimum supply strategy.

The addresses of all sales partners certified by Schaeffler can be found at www.schaeffler.de/sales.

Mounting Toolbox – mounting made easy

The Schaeffler Mounting Toolbox, *Figure 2*, brings together valuable knowledge relating to the mounting and dismantling of rolling bearings. In individual video sequences, the service experts present step by step the points that must be paid close attention for correct mounting, lubrication and alignment. The interface is a “Virtual Plant” and offers the user easy, rapid navigation. With just a few clicks of the mouse, it is possible to gain an overview of the tools and accessories as well as to select individual video sequences. Internet access is all that is needed to enter the “Virtual Plant” and watch the Schaeffler fitting personnel at work.

Here is the link to the Mounting Toolbox:
<http://mtb.schaeffler.de>

Figure 2
Mounting Toolbox

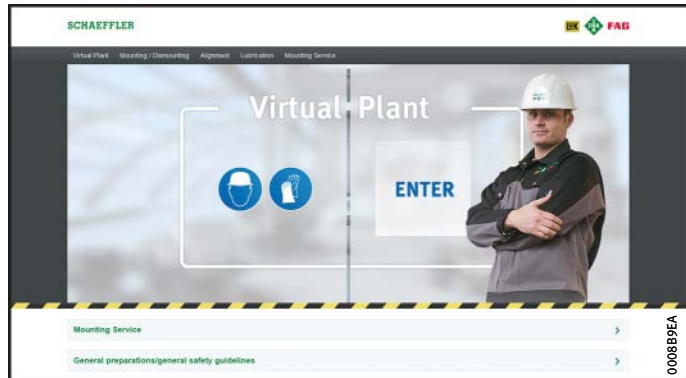

Contents

	Page
Product index	8
Tab index	12
Products: Mounting	15
Products: Lubrication	77
Products: Condition Monitoring	95
Services	130
Training.....	150
Appendix	
Publications	158
Addresses	160

Product index

	Page
ARCA-GREASE-GUN	Lever grease gun..... 87
ARCA-PUMP	Grease dispensing unit 87
ARCA-PUMP-BARREL	Drum pump 87
ARCA-PUMP-BARREL.GUN-METER	Pistol grease gun 86
ARCA-PUMP-WIND-SERVICE-KIT	Service pump for wind turbines 86
ARCANOL-ANTICORROSIONOIL	Anti-corrosion oil 72
ARCANOL-MOUNTINGPASTE	Mounting paste 72
ARCANOL-BIO2	Special grease for environmentally hazardous applications 82
ARCANOL-CLEAN-M	Special grease for clean room applications..... 82
ARCANOL-FOOD2	Special grease for applications with food contact 82
ARCANOL-LOAD150	Greases for high loads, high speed 80
ARCANOL-LOAD220	Greases for high loads, high speed 80
ARCANOL-LOAD400	Greases for high loads, moderate speed..... 80
ARCANOL-LOAD460	Greases for high loads, moderate speed..... 80
ARCANOL-LOAD1000	Greases for high loads, low speed 80
ARCANOL-MULTITOP	Multi-purpose grease for high speed, high loads, high temperatures..... 80
ARCANOL-MULTI2	Multi-purpose grease for bearings under normal loads ($D \leq 62$) 80
ARCANOL-MULTI3	Multi-purpose grease for bearings under normal loads ($D > 62$) 80
ARCANOL-SPEED2,6	Special grease for very high speeds, low temperatures 82
ARCANOL-TEMP90	Special grease for low and high temperatures..... 82
ARCANOL-TEMP110	Special grease for low and high temperatures, high speed..... 82
ARCANOL-TEMP120	Special grease for high temperatures, high speed..... 82
ARCANOL-TEMP200	Special grease for very high temperatures 82
ARCANOL-VIB3	Special grease for high loads, high temperatures, oscillating motion 82
BEARING-MATE	Transport and mounting tool 72
CONCEPT2	Two-point lubricator CONCEPT2 with grease cartridge 86
CONCEPT8	Multi-point lubrication system CONCEPT8 with LC unit 86

	Page
DETECT3-KIT	Vibration measuring device Detector III 116
DETECT3-KIT-RFID	Vibration measuring device Detector III with automatic measurement point detection..... 116
DETECT3.BALANCE-KIT	Balancing function for Detector III 116
DTECTX1-S	Online monitoring system DTECT X1 _s 116
DTECTX1-S-WIPRO	Online monitoring system WiPro _s 116
FEELER-GAUGE-100	Feeler gauge 66
FEELER-GAUGE-300	Feeler gauge 66
FITTING-TOOL-ALU-10-50	Mounting tool set 18
GLOVE-PRO	Heat-resistant gloves 72
GLOVE-PRO-CUT	Heat-resistant and cut-resistant gloves 72
GLOVE-PRO-TEMP	Heat-resistant and oil-resistant gloves 72
GREASE-CHECK	Grease sensor GreaseCheck..... 126
HEATING-RING	Heating ring..... 48
HEATING-RING.PASTE	Heat-conducting paste..... 48
HEATER10	Induction heating device for workpieces up to a mass of 10 kg..... 52
HEATER20	Induction heating device for workpieces up to a mass of 20 kg..... 52
HEATER40	Induction heating device for workpieces up to a mass of 40 kg..... 52
HEATER150	Induction heating device for workpieces up to a mass of 150 kg..... 52
HEATER300	Induction heating device for workpieces up to a mass of 300 kg..... 52
HEATER600	Induction heating device for workpieces up to a mass of 600 kg..... 53
HEATER1200	Induction heating device for workpieces up to a mass of 1 200 kg 53
HEATER-PLATE	Electric heating plate 48
HEATER-PLATE-370C	Electric heating plate 48
HEAT-GENERATOR	Generator for heating device with medium frequency technology 62
HEAT-INDUCTOR	Inductor for heating device with medium frequency technology 62
HYDNUT	Hydraulic nut..... 32
INJECT1600	Oil injector 1 600 bar 32
INJECT2500	Oil injector 2 500 bar 32
KLR	Taper ring gauge..... 66

Product index

	Page
LASER-EQUILIGN	Shaft alignment device Top-Laser EQUILIGN 98
LASER-SHIM	Shim Top-Laser SHIM 98
LASER-SMARTY2	Belt pulley alignment device Top-Laser SMARTY2 98
LASER-TRUMMY2	Belt tension measuring device Top-Laser TRUMMY2..... 98
LOCKNUT-DOUBLEHOOK	Double hook wrench 19
LOCKNUT-DOUBLEHOOK-...-SET	Double hook wrench set..... 19
LOCKNUT-FACEPIN	Jointed face wrench 19
LOCKNUT-FLEXIHOOK	Jointed hook wrench 18
LOCKNUT-FLEXIPIN	Jointed pin wrench 18
LOCKNUT-HOOK	Hook wrench..... 18
LOCKNUT-HOOK-KM0-16-SET	Hook wrench set 18
LOCKNUT-SOCKET	Socket wrench 18
MGA31	Enveloping circle gauge for external enveloping circle..... 66
MGI21	Enveloping circle gauge for internal enveloping circle 66
MGK132	Taper gauge..... 66
MGK133	Taper gauge..... 66
PRO-CHECK	Online monitoring system ProCheck 116
PRO-TORQ	Online monitoring system ProTorq..... 124
PULLER-BORE...-SET	Internal extractor 20
PULLER-HYD	Hydraulic extractor..... 20
PULLER-INTERNAL10-100-SET	Internal extractor 20
PULLER-SEPARATOR	Separation and extraction device 19
PULLER-SPECIAL	Special bearing extractor 20
PULLER-SPECIAL-BASIC	Special bearing extractor 20
PULLER-SPECIAL-CUSTOM	Special bearing extractor 20
PULLER-SUPPORT	Hydraulic pressure tool 19
PULLER-TRISECTION	Three-section extraction plate 20
PULLER-2ARM	Two-arm extractor 19
PULLER-2ARM-SEPARATOR	Two-arm extractor 19
PULLER-2ARM-SET	Two-arm extractor 19
PULLER-3ARM	Three-arm extractor..... 19

	Page
PUMP1000-0,7L	Single stage hand pump 32
PUMP1000-4L	Twin stage hand pump..... 32
PUMP1000-4L-CONTROL	Twin stage hand pump with digital manometer..... 32
PUMP1000-8L	Twin stage hand pump..... 32
PUMP1000.MANO-DIGI	Digital manometer 33
PUMP1000.MANO-G1/2	Manometer..... 34
PUMP1600-4L	Twin stage hand pump..... 32
PUMP1600-8L	Twin stage hand pump..... 32
PUMP1600.MANO-G1/2	Manometer..... 34
PUMP1600.VALVE-NIPPLE	Nipple for rapid push fit couplings 33
PUMP1600.VALVE-SOCKET	Socket for rapid push fit couplings..... 33
PUMP2500-0,2L-KIT	High pressure pump 33
PUMP2500-4L	Twin stage hand pump..... 32
PUMP2500-8L	Twin stage hand pump..... 32
PUMP2500.MANO-G1/2	Manometer..... 34
PUMP4000-0,2L	High pressure pump 33
PUMP.ADAPTER	Adapter 33
PUMP.HOLDER-2	Pump holder..... 33
PUMP.HOLDER-3	Pump holder..... 33
PUMP.NIPPLE	Adapter and reduction nipple 33
PUMP.PIPE	High pressure pipe 34
PUMP.SLEEVE-CONNECTOR	Sleeve connector 34
SMART-CHECK	Online monitoring system SmartCheck..... 116
SNAP-GAUGE	Snap gauge 66
SOUND-CHECK	Sonar device 110
TACHOMETER	Digital hand tachometer 110
TEMP-CHECK-PLUS	Temperature measuring device TempCheck PLUS 110
TEMP-CHECK-PRO	Temperature measuring device TempCheck PRO..... 110
TOOL-RAILWAY-AGGREGATE	Mobile hydraulic unit for batch mounting of TAROL bearings.... 33
WEAR-DEBRIS-CHECK	Oil sensor Wear Debris Check 126



00019349

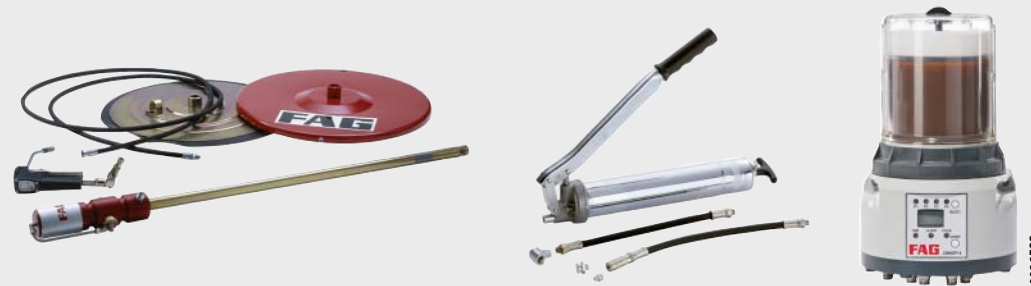

00089FCC



00019DD4



00019344

Products: Mounting



00084942

Products: Lubrication



00019DD6

Products: Condition Monitoring



00017AF2

Services



00017B16

Training courses



0001A281

Appendix

- Publications
- Addresses

FAG



Products: Mounting

Products: Mounting

	Page
Mechanical mounting and dismounting	Product overview 18
	Features
	Mounting tool sets 21
	Socket wrenches 22
	Hook and pin wrenches 23
	Mechanical extractors 25
	Hydraulic extractors 30
	Three-section extraction plates 31
Hydraulic mounting and dismounting	Product overview 32
	Features
	Software Mounting Manager 35
	Hydraulic nuts 36
	Pressure generation devices 38
	Mobile hydraulic unit 43
	Connectors, accessories 45
Thermal mounting and dismounting, contact heating	Product overview 48
	Features
	Electric heating plates 49
	Heating rings 50
	Heat-conducting paste 51
Thermal mounting, induction heating devices	Product overview 52
	Features
	Induction heating devices HEATER 54
	Function 56
	FAG Heating Manager 57
	Dimension tables
	Heating devices HEATER, product range 58

	Page
Thermal mounting and dismounting, medium frequency technology	
Product overview	62
Features	
Induction units with medium frequency technology	63
Measurement and inspection	
Product overview	66
Features	
Feeler gauges.....	67
Taper ring gauges and taper gauges	67
Snap gauges.....	69
Enveloping circle gauges.....	70
Accessories	
Product overview	72
Features	
Transport and mounting tool	73
Gloves	74
Mounting paste.....	75
Anti-corrosion oil	75



Product overview Mechanical mounting and dismounting

Mounting tool sets

FITTING-TOOL-ALU-10-50



Socket wrenches

LOCKNUT-SOCKET



Hook and pin wrenches

Hook wrenches

LOCKNUT-HOOK



LOCKNUT-HOOK-KM0-16-SET



Jointed hook wrenches
Jointed pin wrenches

LOCKNUT-FLEXIHOOK



LOCKNUT-FLEXIPIN



Jointed face wrenches
Double hook wrenches

LOCKNUT-FACEPIN



LOCKNUT-DOUBLEHOOK



Double hook wrench sets

LOCKNUT-DOUBLEHOOK...-SET



Mechanical extractors

Two-arm extractors
Two-arm extractor set

PULLER-2ARM,
PULLER-2ARM-SEPARATOR



PULLER-2ARM-SET



Three-arm extractors
Hydraulic pressure tool

PULLER-3ARM

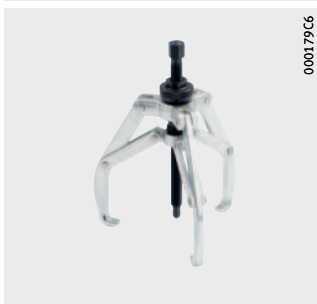

PULLER-SUPPORT



Product overview Mechanical mounting and dismounting

Special bearing extractors
Separation and extraction devices

PULLER-SPECIAL-BASIC,
PULLER-SPECIAL



00017AD5

PULLER-SPECIAL-CUSTOM

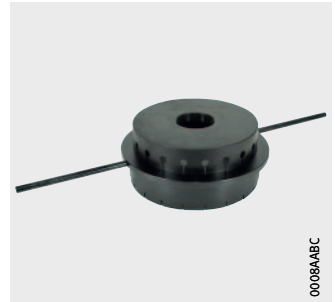

0008A4BC

Internal extractors

PULLER-BORE...-SET



00019290

PULLER-INTERNAL10-100-SET



00019292

Hydraulic extractors

PULLER-HYD



0008A4DB

PULLER-HYD175,
PULLER-HYD400



0008A4CS

Three-section
extraction plates

PULLER-TRISECTION



00017995

Mechanical mounting and dismantling



Features	These mechanical tools are designed for the mounting and dismantling of bearings. The mounting forces are transmitted by the form fit effect.
Mounting tool sets	<p>The mounting tool sets are suitable for the simple mounting of rolling bearings up to 50 mm bore. They can also be used for the mounting of sleeves, intermediate rings, seals and similar parts.</p> <p>A mounting tool set contains mounting sleeves made from aluminium and mounting rings made from plastic.</p> <p>An error frequently made during mounting is to transmit the mounting forces through the rolling elements and raceways. This error can be avoided by driving the inner ring onto the shaft or driving the outer ring into the housing by applying hammer blows to an appropriate mounting sleeve. The carefully matched precision parts ensure that the forces are uniformly transmitted to the side faces of the bearing rings.</p>
Scope of delivery	Mounting tool set comprising 33 mounting rings for bearing bore 10 mm to 50 mm and outside diameter up to 110 mm 3 mounting sleeves 1 recoilless hammer, mass 1 kg 1 case
Ordering designation	FITTING-TOOL-ALU-10-50 Also available as individual parts.
Further information	<ul style="list-style-type: none">■ For detailed information, see TPI 216, FAG Tools for Mechanical Mounting and Dismounting of Rolling Bearings.■ Enquiries: industrial-services@schaeffler.com, +49 2407 9149-66.

Mechanical mounting and dismounting

Socket wrenches	<p>Socket wrenches LOCKNUT-SOCKET are suitable for easily tightening and loosening locknuts on shafts, adapter sleeves and withdrawal sleeves. They require less space on the circumference of the nut than hook wrenches and allow the use of ratchets and torque wrenches.</p> <p>For increased reliability, socket wrenches should be secured using a locking pin and rubber washer. They therefore have a hole for the locking pin and a groove for the rubber washer. The locking pin and rubber washer are included in the scope of delivery.</p> <p>Socket wrenches are available in sizes suitable for locknuts KM0 to KM20. Other sizes and special solutions are available by agreement.</p>
Scope of delivery	<p>1 socket 1 locking pin 1 rubber washer</p>
Ordering example	Socket wrench, suitable for locknut KM5
Ordering designation	LOCKNUT-SOCKET-KM5 Special sizes available by agreement.
Further information	<ul style="list-style-type: none">■ For detailed information, see TPI 216, FAG Tools for Mechanical Mounting and Dismounting of Rolling Bearings.■ Enquiries: industrial-services@schaeffler.com, +49 2407 9149-66.

Hook and pin wrenches

These wrenches can be used for the mounting and dismounting of small bearings on shaft seats, adapter sleeves or withdrawal sleeves. In addition to the sizes named here, other sizes are available by agreement.



Hook wrenches

Hook wrenches LOCKNUT-HOOK can be used to dismount not only bearings but also withdrawal sleeves with the aid of extraction nuts. Hook wrenches are available in sizes suitable for locknuts KM0 to KM40, suitable for diameters from 16 mm to 245 mm.

Ordering example
Ordering designation

Hook wrench, suitable for locknuts KM18, KM19 and KM20

LOCKNUT-HOOK-KM18-20

Hook wrenches can also be ordered as a set. The set comprises ten hook wrenches of sizes KM0 to KM16 in a roll-up pouch and is suitable for diameters from 16 mm to 100 mm.

Ordering example
Ordering designation

Set of ten hook wrenches

LOCKNUT-HOOK-KM0-16-SET

Jointed hook wrenches

The joint allows one hook wrench LOCKNUT-FLEXIHOOK to be used for mounting or dismounting locknuts of various sizes.

Jointed hook wrenches are available in sizes suitable for locknuts KM1 to KM36, suitable for diameters from 20 mm to 230 mm.

Ordering example
Ordering designation

Jointed hook wrench, suitable for locknuts KM14 to KM24

LOCKNUT-FLEXIHOOK-KM14-24

Jointed pin wrenches

The jointed pin wrench LOCKNUT-FLEXIPIN is hooked into radially arranged holes in the nut.

Jointed pin wrenches are available in sizes suitable for locknuts AM15 to AM90, suitable for diameters from 35 mm to 155 mm.

Ordering example
Ordering designation

Jointed pin wrench, suitable for precision locknuts AM35 to AM60

LOCKNUT-FLEXIPIN-AM35-60

Mechanical mounting and dismounting

Jointed face wrenches	<p>The jointed face wrench LOCKNUT-FACEPIN is hooked into axially arranged holes in the nut.</p> <p>Jointed face wrenches are available in sizes suitable for precision locknuts LNP017 to LNP170, suitable for diameters from 18 mm to 200 mm.</p>
Ordering example	Jointed face wrench, suitable for precision locknuts LPN017 to LPN025
Ordering designation	LOCKNUT-FACEPIN-LNP17-25
Double hook wrenches	<p>Double hook wrenches LOCKNUT-DOUBLEHOOK are intended for the mounting of spherical roller bearings and self-aligning ball bearings with a tapered bore. The individual wrenches are available as a set.</p> <p>The double hook wrench sets contain a torque wrench. This allows a precisely defined tightening torque to be achieved at the start of the mounting operation.</p> <p>Double hook wrench sets are suitable for several sizes of locknuts. There is one set each for locknuts KM3 to KM8 and for locknuts KM9 to KM15. All the parts in the scope of delivery are also available individually.</p> <p>Each double hook wrench is engraved with the torsion angles for the appropriate spherical roller bearings and self-aligning ball bearings. The drive-up distance and reduction in radial internal clearance can therefore be precisely set.</p>
Scope of delivery of double hook wrench set	<p>Several double hook wrenches</p> <ul style="list-style-type: none">1 torque wrench1 mounting lever1 user manual1 case1 mounting paste (20 g)
Ordering example	4 double hook wrenches, suitable for locknuts KM3 to KM8
Ordering designation	LOCKNUT-DOUBLEHOOK-KM3-8-SET
Ordering example	5 double hook wrenches, suitable for locknuts KM9 to KM15
Ordering designation	LOCKNUT-DOUBLEHOOK-KM9-15-SET
Further information	<ul style="list-style-type: none">■ For detailed information, see TPI 216, FAG Tools for Mechanical Mounting and Dismounting of Rolling Bearings.■ Enquiries: industrial-services@schaeffler.com, +49 2407 9149-66.

Mechanical extractors

Mechanical extractors can be used to dismount small and medium sized rolling bearings that are located with a tight fit on a shaft or in a housing. The bearing can be dismounted without damage if the extractor is in contact with the tightly fitted bearing ring.

In the case of mechanical extractors, the extraction force is normally applied by means of threaded spindles.

In addition to the two-arm and three-arm devices as well as a hydraulic pressure tool, special solutions are also possible.

For dismounting of larger bearings, hydraulic extractors should be used, see page 30.



Two-arm and three-arm extractors

Two-arm and three-arm extractors, *Figure 1* and tables, page 26, are used for the extraction of complete rolling bearings or tightly fitted inner rings.

The two-arm extractor PULLER-2ARM and three-arm extractor PULLER-3ARM can also be used to extract other parts such as gears.

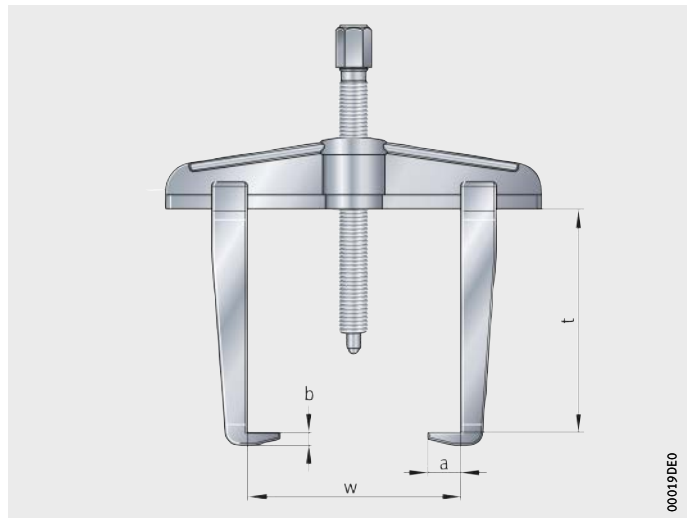

Figure 1
Dimensions of the gripper

Mechanical mounting and dismounting

Available two-arm extractors

Designation	Grip width	Grip depth	Dimensions		Extraction force kN
	w mm	t mm	a mm	b mm	
PULLER-2ARM90	90	100	15	22	30
PULLER-2ARM130	130	100	15	22	30
PULLER-2ARM160	160	150	24	30	50
PULLER-2ARM200	200	150	24	30	50
PULLER-2ARM250	250	200	32	36	75
PULLER-2ARM350	350	200	32	36	75
PULLER-2ARM-SEPARATOR45	45	65	2,5	12 + 1	10
PULLER-2ARM-SEPARATOR90	90	100	2,5	14 + 1	40
PULLER-2ARM-SEPARATOR150	150	150	2,5	28 + 1	40

Available two-arm extractor set

Designation: PULLER-2ARM-SET
Two-arm extractors included
PULLER-2ARM130, PULLER-2ARM200, PULLER-2ARM350
Accessories included
Narrow extraction hook for size 130 and 200, tube of spindle grease, carry case

Available three-arm extractors

Designation	Grip width	Grip depth	Dimensions		Extraction force kN
	mm	mm	a mm	b mm	
PULLER-3ARM160	160	100	14 + 1	15 + 1	45
PULLER-3ARM230	230	165	19 + 1	22 + 1	100
PULLER-3ARM310	310	235	19 + 1	22 + 1	100
PULLER-3ARM430	430	240	20 + 2	30 + 2	150
PULLER-3ARM660	660	340	22 + 2	34 + 2	150

Hydraulic pressure tool

The pressure tool PULLER-SUPPORT, see table, is used to loosen tightly fitted parts in conjunction with mechanical extractors. It is applied between the shaft end and extractor spindle.



The spindle diameter of the extractor must not be less than the stated minimum value, see table.

The maximum torque must be observed.

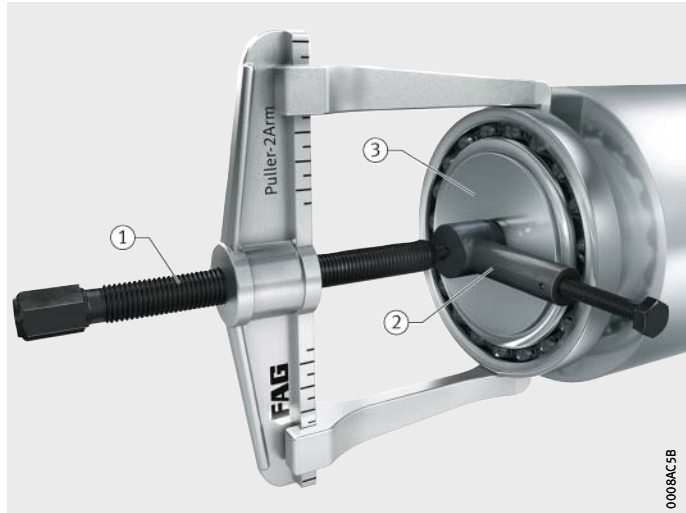

- ① Extractor spindle
- ② Pressure tool
- ③ Shaft end

Figure 2
Pressure tool

Available pressure tools

Designation	Axial force	Minimum spindle diameter mm	Maximum torque Nm
	kN		
PULLER-SUPPORT80	80	M22	25
PULLER-SUPPORT150	150	M30	50

Mechanical mounting and dismounting

Special bearing extractors	<p>Special bearing extractors PULLER-SPECIAL can be used to dismount radial bearings of the following types: deep groove ball bearings, self-aligning ball bearings, cylindrical roller, tapered roller and spherical roller bearings (inner rings only), angular contact ball bearings and four point contact bearings.</p> <p>The special bearing extractor comprises the base device and a collet. When the base device is progressively screwed down, this closes the collet and clamps it against the inner ring.</p> <p>The base device is available in four sizes. The collet must be specifically ordered to match the bearing. Large collets are operated using hydraulic cylinders; these collets are available by agreement.</p>
Ordering example Base device	Base device for bearings with inside diameter up to 30 mm
Ordering designation	PULLER-SPECIAL-BASIC30
Ordering example Collet	Collet for deep groove ball bearing 6005
Ordering designation	PULLER-SPECIAL-A-6005
Ordering example Collets	Collets for pair of tapered roller bearings 30203-A in X arrangement
Ordering designation	PULLER-SPECIAL-B-30203A, PULLER-SPECIAL-C-30203A

Internal extractor sets

The internal extractor set PULLER-BORE, see table, can be used for the dismantling of small deep groove and angular contact ball bearings where the outer ring has a tight fit. The inner ring bore must be easily accessible.

The internal extractors can also be ordered individually.

The internal extractor set PULLER-INTERNAL can be used for the dismantling of standard deep groove ball bearings where the outer ring has a tight fit. It is not necessary to dismantle the shaft.

Internal extractors, countersupports and impact extractors can also be ordered individually.



Available internal extractor sets

Designation	Diameter range		Scope of delivery
	min. mm	max. mm	
PULLER-BORE5-39-SET	5	39	6 internal extractors 1 countersupports 1 impact extractor 1 carry case
PULLER-BORE40-79-SET	40	79	4 internal extractors 1 countersupport 1 impact extractor 1 carry case
PULLER-INTERNAL-10-100-SET	10	100	6 extraction legs 2 screw spindles 1 carry case

Further information

- For detailed information, see TPI 216, FAG Tools for Mechanical Mounting and Dismounting of Rolling Bearings.
- Enquiries: industrial-services@schaeffler.com, +49 2407 9149-66.

Mechanical mounting and dismounting

Hydraulic extractors

The hydraulic extractors, see tables, are used where higher extraction forces are required.

These devices allow rolling bearings, gears, sleeves and many other shrink fitted parts to be quickly and easily dismounted.

For larger grip depths, longer extraction arms are available (accessories).

Operating personnel can be protected by means of a safety grid or a safety cover.

The advantageous features of hydraulic extractors are as follows:

- parts under mechanical load are made from high quality chromium-molybdenum steel
- the smooth-running piston is made from chromium plated, hardened and tempered steel
- stroke travel adjustable by means of standard adapter
- screw thread for setting of optimum grip depth
- simple centring by spring-loaded steel cone
- simple conversion to two-arm operation if there is insufficient space for three arms
- optimum operating position due to rotatable pump hand lever or separate pump.

Available hydraulic extractors with integral hand pump

Designation	Extraction force kN	Grip width		Grip depth		Stroke mm
		Standard mm	XL mm	Standard mm	XL mm	
PULLER-HYD40	40	200	–	165	–	55
PULLER-HYD60 (-XL)	60	200	220	165	195	80
PULLER-HYD80 (-XL)	80	250	300	210	240	80
PULLER-HYD100 (-XL)	100	250	280	195	250	80
PULLER-HYD120 (-XL)	120	300	330	240	280	80
PULLER-HYD200 (-XL)	200	360	380	275	330	80
PULLER-HYD250 (-XL)	250	410	440	315	385	100
PULLER-HYD300 (-XL)	300	540	610	375	405	100

Available hydraulic extractors with separate hand pump

Designation	Extraction force kN	Grip width		Grip depth		Stroke mm
		Standard mm	XL mm	Standard mm	XL mm	
PULLER-HYD400 (-XL)	400	580	1 000	420	635	120

Further information

- For detailed information, see TPI 216, FAG Tools for Mechanical Mounting and Dismounting of Rolling Bearings.
- Enquiries: industrial-services@schaeffler.com, +49 2407 9149-66.

Three-section extraction plates

Three-section extraction plates PULLER-TRISECTION, see table, can be used with hydraulic and mechanical extractors.

These allow the extraction of complete bearings, tightly fitted inner rings and other components. The load capacity and extraction force are precisely matched to each other.

The extraction claws grip directly under the screw studs of the extraction plates and give uniform distribution of force. Even where parts have a tight fit, there is no tilting or bending. The high extraction forces are concentrated on the bearing inner ring. In general, the bearing and shaft remain intact and can be used again.

The extraction plates can be fitted under the bearing with just a few movements.

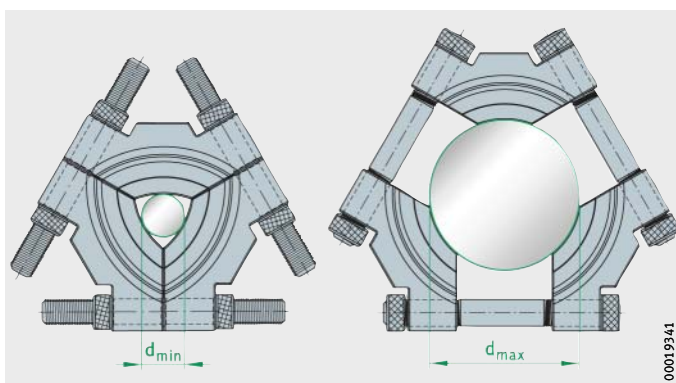

Figure 3
Maximum and minimum diameter of extraction plates, see table

Available extraction plates, d_{min} and d_{max} see Figure 3

Designation	Dimensions		Recommended for extractor	
	d_{min} mm	d_{max} mm	PULLER-HYD	PULLER-3ARM
PULLER-TRISECTION-50	12	50	–	160
PULLER-TRISECTION-100	26	100	40, 60, 80, 100	230
PULLER-TRISECTION-160	50	160	80, 100, 120, 175, 200	310
PULLER-TRISECTION-260	90	260	175, 200, 250, 300	430
PULLER-TRISECTION-380	140	380	250, 300, 400	660

Further information

- For detailed information, see TPI 216, FAG Tools for Mechanical Mounting and Dismounting of Rolling Bearings.
- Enquiries: industrial-services@schaeffler.com, +49 2407 9149-66.

Product overview Hydraulic mounting and dismounting

Hydraulic nuts Oil injectors

HYDNUT



INJECT2500, INJECT1600



Hand pumps Single stage

PUMP1000-0,7L



Twin stage

PUMP1000-4L, PUMP1000-8L, PUMP1600-4L, PUMP1600-8L,
PUMP2500-4L, PUMP2500-8L



For drive-up distance

PUMP1000-4L-CONTROL



High pressure pumps

PUMP4000-0,2L



PUMP2500-0,2L-KIT



Mobile hydraulic unit Tool set

TOOL-RAILWAY-AGGREGATE



TOOL-RAILWAY-AXLE



Connectors, accessories Adapters and reduction nipples Rapid push fit coupling

PUMP.NIPPLE,
PUMP.ADAPTER



PUMP1600.VALVE-NIPPLE,
PUMP1600.VALVE-SOCKET



Pump holder Digital manometer

PUMP.HOLDER-2,
PUMP.HOLDER-3



PUMP1000.MANO-DIGI



Product overview Hydraulic mounting and dismounting

Manometer
High pressure pipe

PUMP1000.MANO-G1/2,
PUMP1600.MANO-G1/2,
PUMP2500.MANO-G1/2



PUMP.PIPE

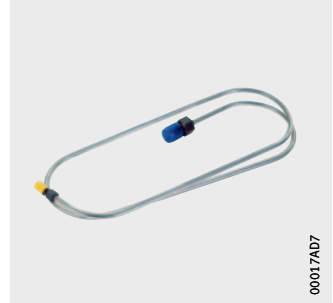

Sleeve connector

PUMP.SLEEVE-CONNECTOR



Hydraulic mounting and dismantling



Features Hydraulic tools can be used to apply large forces. These tools are therefore particularly suitable for the mounting and dismantling of large bearings or parts with a tapered bore.

Hydraulic nuts are used as a mounting tool. Pressure can be generated using oil injectors, hand pumps or hydraulic units.

Software Mounting Manager

The software Mounting Manager gives assistance in selecting the correct mounting of bearings and offers the following options:

- It shows various mechanical and hydraulic mounting methods.
- It calculates the data required for mounting in relation to reduction in radial internal clearance, drive-up distance and start pressure.
- It gives advice on mounting.
- It generates a list of the accessories and tools required.

It also contains a library with references to publications giving further information and an electronic learning system.

The software Mounting Manager is available online at mountingmanager.schaeffler.com

Mounting methods

Bearings with a tapered bore are mounted either directly on the tapered shaft or journal or by means of an adapter sleeve or withdrawal sleeve on the cylindrical shaft. The internal clearance is set either by measurement of the axial drive-up distance or by conventional means using feeler gauges.

Measurement of the axial drive-up distance

The bearing is placed in its start position on the tapered bearing seat using a hydraulic nut. The start pressure, which is defined for each bearing, is checked using a digital manometer on the hand pump PUMP1000-4L-CONTROL. A certain quantity of oil is required in order to reach the specified drive-up distance. This is achieved by using a defined number of strokes. The number of strokes can be read off from the stroke counter on this hand pump.

The advantages of this mounting method are as follows:

- simplified mounting
- very high security and accuracy
- correct mounting of sealed bearings.

Measurement of the reduction in radial internal clearance

When the bearing is driven onto the tapered seat, the inner ring is expanded and the radial internal clearance is thereby reduced. This reduction in radial internal clearance is an indication of the tight fit of the bearing. Measurement is carried out using a feeler gauge.

Hydraulic mounting and dismounting

Hydraulic nuts

Hydraulic nuts HYDNUT, *Figure 1* and table, are used to press components with a tapered bore onto their tapered seat. Presses are mainly used if the drive-up forces required cannot be applied using other accessories, e.g. shaft nuts or pressure screws.

- ① Handling holes
- ② Oil connector

Figure 1
Hydraulic nut with thread

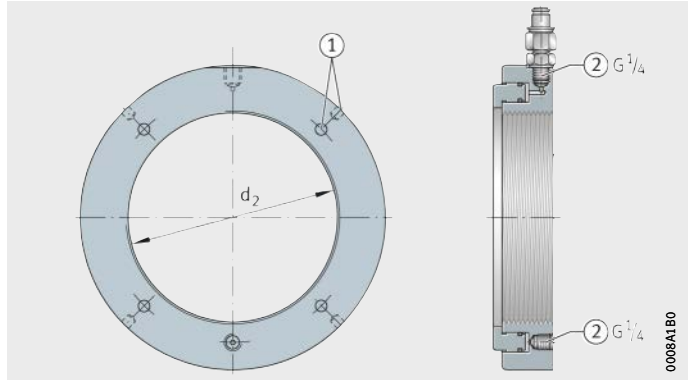

The main applications are as follows:

- mounting and dismounting of rolling bearings with tapered bore.
The bearings can be seated directly on a tapered shaft, an adapter sleeve or a withdrawal sleeve. The hydraulic nut can also be used for the dismounting of adapter or withdrawal sleeves.
- mounting and dismounting of components such as couplings, gears and ships' propellers.

Available hydraulic nuts

Designation	Design	Application
HYDNUT50 to HYDNUT200	With metric fine pitch thread to DIN 13	Standardised adapter and withdrawal sleeves
HYDNUT205 to HYDNUT1180	With trapezoidal thread to DIN 103	With metric dimensions
HYDNUT90-INCH to HYDNUT530-INCH	With inch size thread to ABMA "Standards for Mounting Accessories, Section 8, Locknut Series N-00"	Sleeves with inch dimensions
HYDNUT100-HEAVY to HYDNUT900-HEAVY	Increased capacity design with smooth bore	For high mounting forces, for example in shipbuilding



- ① Hydraulic nut
- ② Replacement seals
- ③ Screw plug
- ④ Eye bolt
- ⑤ Connecting nipple
- ⑥ Hand lever
- ⑦ Mounting paste
- ⑧ User manual

Figure 2
Scope of delivery
Hydraulic nut

Scope of delivery

- 1 hydraulic nut
- 2 replacement seals
- 1 screw plug
- 1 connecting nipple
- 1 eye bolt
- 1 hand lever
- 1 mounting paste
- 1 user manual

Ordering designation

HYDNUT

Further information

- For detailed information, see TPI 196, FAG Hydraulic Nuts.
- Enquiries: industrial-services@schaeffler.com, +49 2407 9149-66.

Hydraulic mounting and dismounting

Pressure generation devices

Pressure generation devices are available in various designs: from oil injectors, through hand pump sets, to high pressure pumps.

Use of pressure generation devices

Type	Designation	Application
Oil injector	INJECT2500	<ul style="list-style-type: none"> Mounting and dismounting of bearings with tapered bore
	INJECT1600	<ul style="list-style-type: none"> Mounting and dismounting of bearings with tapered bore
Hand pump	PUMP1000-0,7L	<ul style="list-style-type: none"> Mounting and dismounting of rolling bearings For driving hydraulic nuts up to HYDNUT395 or HYDNUT300-HEAVY
	PUMP1000-4L	<ul style="list-style-type: none"> Mounting and dismounting of rolling bearings Mounting and dismounting of components such as ships' propellers For driving hydraulic nuts up to HYDNUT800
	PUMP1000-4L-CONTROL	<ul style="list-style-type: none"> Mounting and dismounting of rolling bearings in conjunction with a hydraulic nut
	PUMP1600-4L	<ul style="list-style-type: none"> Mounting and dismounting of rolling bearings Mounting and dismounting of components such as rudder splines and rudder blades
	PUMP2500-4L	<ul style="list-style-type: none"> Mounting and dismounting of bearings Mounting and dismounting of components such as gears and couplings
High pressure pump	PUMP4000-0,2L	<ul style="list-style-type: none"> Dismounting of bearings For interference fits with high contact pressure Delivery rate and oil reservoir are small
	PUMP2500-0,2L-KIT	<ul style="list-style-type: none"> Dismounting of bearings For interference fits with high contact pressure Delivery rate and oil reservoir are small

Further information

- For detailed information, see TPI 195, FAG Pressure Generation Devices.

Oil injectors

Oil injectors have only a small delivery volume, see table. They are suitable for the dismantling of rolling bearings and other press fits with direct seating on tapered shafts, *Figure 3*.



- ① Oil injector
- ② Valve nipple
- ③ Shaft

Figure 3
Oil injector

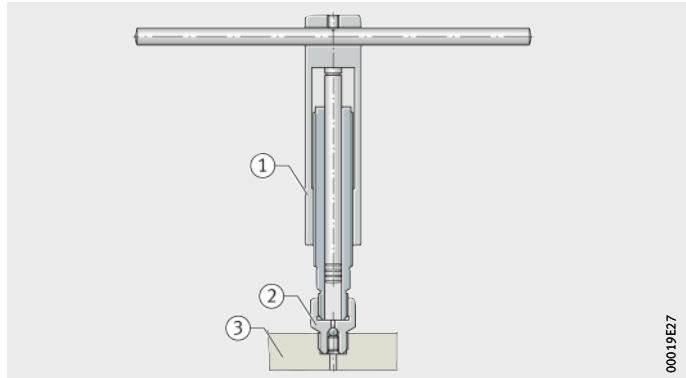

Conventional O rings can be used as replacement seals: OR6~1,5 (for INJECT2500), OR10~2,0 (for INJECT1600).

The oil injector can be refilled with oil without losses by connecting a valve nipple.

Available oil injectors

Designation Set		Connector	Oil volume cm ³	Maximum oil pressure bar	For shaft diameter up to mm
Oil injector	Valve nipple				
INJECT2500.SET					
INJECT2500	INJECT2500.VALVE	G ^{3/8}	8	2 500	80
INJECT1600.SET					
INJECT1600	INJECT1600.VALVE	G ^{3/4}	27	1 600	150

Ordering example for set

Oil injector with maximum oil pressure of 2 500 bar

Valve nipple

Ordering designation

INJECT2500-SET

Oil injectors and valve nipples can also be ordered individually.

Hydraulic mounting and dismantling

Hand pumps Hand pumps have a single stage or twin stage pump with a manometer.

Single stage pump The hand pump PUMP1000-0,7L has an oil container with a volume of 0,7 l. The maximum pressure is 1 000 bar, see table. A digital manometer is available as an accessory.

Available single stage pump

Designation	Maximum oil pressure bar
PUMP1000-0,7L	1 000

Twin stage pump The twin stage pumps, *Figure 4* and table, have a high delivery rate up to 50 bar and then switch automatically to the high pressure stage. This gives a high work rate.



Figure 4
Twin stage pump,
4-l oil container

Where there is an increased oil requirement, the twin stage pumps are available with an 8 l oil container (suffix 8L). If the type of installation of the adapter or withdrawal sleeve requires a separate oil supply, a two-way valve is available (suffix D).

For pumps with an oil pressure of 1 000 bar and a connector, digital manometers are also available as accessories.

Available twin stage pumps

Designation	Maximum oil pressure bar
PUMP1000-4L	1 000
PUMP1600-4L	1 600
PUMP2500-4L	2 500

Pump for drive-up distance

The hand pump PUMP1000-4L-CONTROL is particularly suitable as a pressure generation device where rolling bearings are to be driven onto their tapered seat using a hydraulic nut, *Figure 5*.



First, the bearing is driven smoothly onto the tapered seat as far as the initial position. A suitable hydraulic nut is then screwed onto the shaft and the hand pump is connected. The hand pump is then operated until the pressure to reach the start position is achieved. The pump is then operated further to drive the bearing by the required drive-up distance and thus achieve the final position.



Always operate the pump together with a manometer.

The user manual for the pump PUMP1000-4L-CONTROL contains a table that shows the number of strokes necessary to achieve the required drive-up distance of the bearing. The required drive-up distance is calculated using the software Mounting Manager.

- ① Hand pump
- ② Hydraulic nut
- ③ Rolling bearing
- ④ Tapered seat
- ⑤ Initial position
- ⑥ Start position
- ⑦ Drive-up distance
- ⑧ Final position

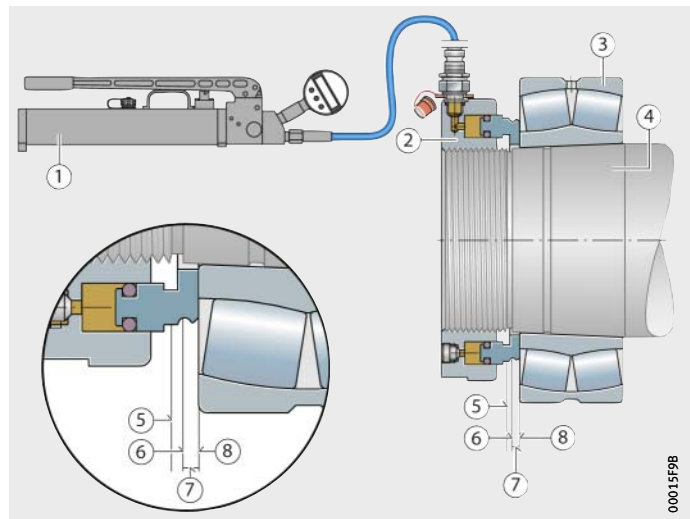

Figure 5
Mounting of a rolling bearing using PUMP1000-4L-CONTROL

Scope of delivery

- 1 hand pump with digital manometer
- 1 high pressure hose with coupling sleeve
- 1 spacer ring (HYDNUT50 to HYDNUT150)
- 1 push fit coupling nipple
- 1 user manual
- 1 metal case

Ordering designation

PUMP1000-4L-CONTROL

Hydraulic mounting and dismounting

High pressure pump

The high pressure pump, *Figure 6*, is suitable for the mounting and dismounting of rolling bearings for shaft diameters up to 250 mm. Due to the high oil pressure available, the pump can also be used to expand and mount heavy shaft couplings and gears by means of the hydraulic method.

The high pressure pump can be connected directly or by means of thick-walled adapters. It can also be connected by means of a pump holder and a 2 m long, flexible high pressure pipe. The oil pressure in this case must not exceed the maximum oil pressure, see table.



Always operate the pump together with a manometer.

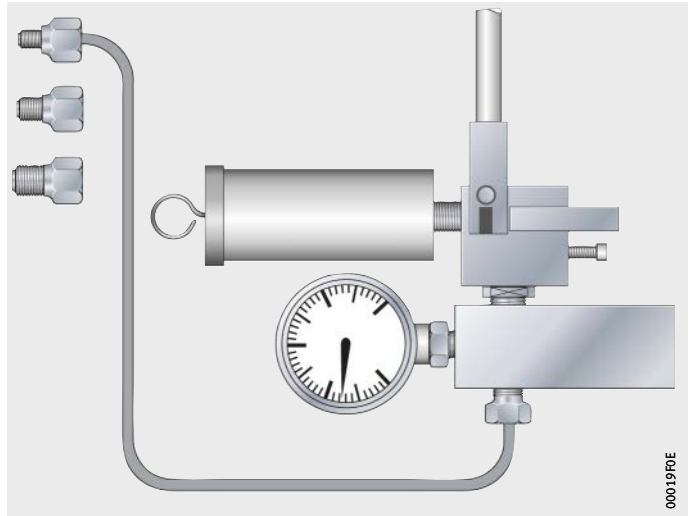

Figure 6
High pressure pump

Available high pressure pump

Designation	Connector	Oil container capacity l	Delivery volume per stroke cm ³	Maximum oil pressure bar
PUMP2500-0,2L	G ^{3/4}	0,2	0,3	2 500
PUMP4000-0,2L	G ^{3/4}	0,2	0,3	4 000

Ordering example
Ordering designation

High pressure pump with maximum oil pressure of 4 000 bar
PUMP4000-0,2L

Further information

- For detailed information, see TPI 195, FAG Pressure Generation Devices.
- Enquiries: industrial-services@schaeffler.com, +49 2407 9149-66.

Mobile hydraulic unit

The mobile hydraulic unit, *Figure 7*, is used for the mounting and dismounting of tapered roller bearing units, also known as TAROL units. These units are used as wheelset bearings in rail vehicles such as goods wagons and passenger carriages.

The mobile unit has a valve-controlled, double direction pressure cylinder driven by a motor pump. The pressure cylinder is adjustable in height.

When making enquiries or placing orders, information on the power connection is required.



Figure 7
Mobile hydraulic unit

Ordering designation

TOOL-RAILWAY-AGGREGATE

00017A51

Hydraulic mounting and dismounting

Tool set Tool sets are produced for a specific application, *Figure 8*. When making enquiries or placing orders, information on the bearing type and installation drawings (shaft, housing, additional parts) are required.



Figure 8
Tool set

Ordering designation

TOOL-RAILWAY-AXLE

Further information

- For detailed information, see:
 - TPI 195, FAG Pressure Generation Devices
 - TPI 156, Tapered Roller Bearing Units TAROL – Mounting, Maintenance, Repair.
- Enquiries: industrial-services@schaeffler.com, +49 2407 9149-66.

Connectors, accessories

Various connectors and accessories are available for use with the devices for hydraulic mounting and dismounting.



Adapters and reduction nipples

Adapters and reduction nipples are matched to the threads of high pressure hoses and pipes, *Figure 9* and tables.

Adapters and reduction nipples of type A (with sealing ring) are suitable for oil pressures up to 800 bar, *Figure 9*. Type B (with blade sealing) is suitable for oil pressures up to 2 500 bar, *Figure 9*.

- ① Type A
- ② Type B

Figure 9

Adapters and reduction nipples

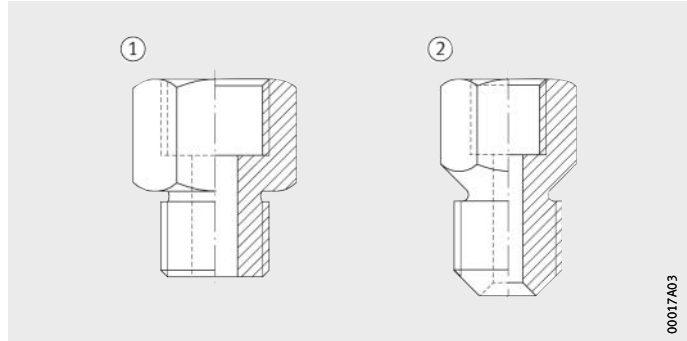

Available adapters and reduction nipples

Designation	Designation
PUMP.NIPPLE-A-G1/4-G1/8	PUMP.NIPPLE-A-G3/4-G1/8
PUMP.NIPPLE-B-G1/4-G1/8	PUMP.NIPPLE-B-G3/4-G1/8
PUMP.NIPPLE-A-G1/4-G1/2	PUMP.NIPPLE-A-G3/4-G1/4
PUMP.NIPPLE-B-G1/4-G1/2	PUMP.NIPPLE-B-G3/4-G1/4
PUMP.NIPPLE-A-G1/4-G3/4	PUMP.NIPPLE-A-G3/4-G3/8
PUMP.NIPPLE-B-G1/4-G3/4	PUMP.NIPPLE-B-G3/4-G3/8
PUMP.NIPPLE-A-G1/4-M14	PUMP.NIPPLE-A-M18×1,5-G1/4
PUMP.NIPPLE-B-G1/4-M14	PUMP.NIPPLE-A-M18×1,5-G3/8
PUMP.NIPPLE-A-G1/4-M18×1,5	PUMP.NIPPLE-A-M18×1,5-G3/8
PUMP.NIPPLE-A-G3/8-G1/4	–
PUMP.NIPPLE-B-G3/8-G1/4	–

Available adapters

Designation	Designation
PUMP.ADAPTER-A-G1/4	PUMP.ADAPTER-A-G3/4
PUMP.ADAPTER-B-G1/4	PUMP.ADAPTER-B-G3/4

Hydraulic mounting and dismantling

Rapid push fit coupling

A suitable connecting nipple is always included in the delivery of a hydraulic nut. Each hand pump with an oil pressure up to 1 600 bar is supplied with a rapid push fit coupling. The rapid push fit coupling allows rapid connection and disconnection of a hose and is suitable for oil pressures up to 1 600 bar, *Figure 10* and table.



After the coupling has been fitted, the high pressure hose must be secured to the connection point by means of a chain or cord.

- ① Nipple
- ② Socket

Figure 10
Rapid push fit coupling



Available nipple and socket

Designation	Threaded connector	Component
PUMP1600.VALVE-NIPPLE	G1/4	Nipple
PUMP1600.VALVE-SOCKET	G1/4	Socket

Pump holders

Pump holders are available with and without a connector G¹/₂ for a manometer, see table.

Available pump holders

Designation	Design
PUMP.HOLDER-2	Pump holder without connector for manometer
PUMP.HOLDER-3	Pump holder with connector for manometer

Manometers

In addition to the manometer with digital display, there are three analogue manometers with an indicator, see table.



When selecting a manometer, pay attention to the maximum oil pressure.



Available manometers

Designation	Threaded connector mm	Maximum oil pressure bar
PUMP1000.MANO-DIGI	G ^{1/4}	1 000
PUMP1000.MANO-G1/2	G ^{1/2}	1 000
PUMP1600.MANO-G1/2	G ^{1/2}	1 600
PUMP2500.MANO-G1/2	G ^{1/2}	2 500

High pressure pipes

High pressure pipes used with high pressure pumps are sheathed in a PVC hose. The maximum permissible oil pressure is 2 500 bar.

The connector to the pump holder is G^{3/4}. The connector to the consumer device is available in the sizes G^{1/4}, G^{3/8}, G^{1/2} and G^{3/4}. For other thread sizes, a reduction nipple can be used.



Check the oil pressure using a manometer.

Ordering example

High pressure pipe with a connector G^{1/4} on the consumer device side

Ordering designation

PUMP.PIPE-G1/4

Sleeve connectors

Sleeve connectors can be used at pressures up to 800 bar.

The connector to the pump holder is G^{1/4}. The connector to the consumer device is available in the sizes M6, M8, G^{1/8} and G^{1/4}. For other thread sizes, a reduction nipple can be used.



Check the oil pressure using a manometer.

Ordering example

Sleeve connector with a connector G^{1/8} on the consumer device side

Ordering designation

PUMP.SLEEVE-CONNECTOR-G1/8

Product overview Thermal mounting and dismounting, contact heating

Electric heating plates

HEATER-PLATE



HEATER-PLATE-370C



Heating rings Heat-conducting paste

HEATING-RING

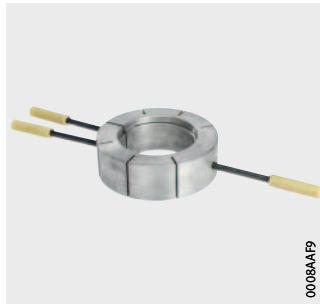

HEATING-RING.PASTE



Thermal mounting and dismounting, contact heating



Features Electric heating plates and heating rings are used to heat rolling bearings and other components with a cylindrical bore where a tight fit on the shaft or in the housing is intended.

Adequate expansion of the bearings is achieved in most cases at +80 °C to +100 °C. During the heating operation, the maximum heating temperature must be observed. The temperature of rolling bearings must not normally exceed +120 °C, in order to prevent changes to the structure and hardness of the bearing. In all devices for heating, the temperature can be steplessly controlled.



Wear protective gloves during mounting and dismounting of heated parts.

Electric heating plates

Heating plates, see table, are used to heat rolling bearings or small machine parts by means of contact heat. Heating plates are maintenance-free and easy to use.

The heating plate HEATER-PLATE-370C is suitable principally for the heating of heating rings HEATING-RING.

Both heating plates are also available as a version with 115 V/60 Hz (suffix 115V).

Available heating plates

Designation	Dimensions		Power at 230 V/50 Hz	Temperature	
	Device	Heating plate		min. °C	max. °C
	mm	mm	W		
HEATER-PLATE	390×270×56	380×180	1 500	+50	+200
HEATER-PLATE-370C	360×360×170	350×350	2 200	+100	+370

Further information

- For detailed information, see TPI 200, FAG Heating Devices for the Mounting of Rolling Bearings.
- Enquiries: industrial-services@schaeffler.com, +49 2407 9149-66.

Thermal mounting and dismantling, contact heating

Heating rings

Heating rings HEATING-RING are suitable for the dismantling of inner rings with a rib and the inner rings of cylindrical and needle roller bearings without ribs. Heating rings are particularly advantageous for the occasional extraction of small and medium-sized bearing rings with a bore diameter of 50 mm to 200 mm.

The heating rings are made from aluminium alloy. They are easy to handle due to the heat-insulated handles.

Heating rings are heated using an electric heating plate to a temperature between +200 °C and +300 °C, *Figure 1*.



- ① Heating ring
- ② Heating plate
- ③ Temperature measuring device

Figure 1
Heating of the heating ring

Each bearing size requires a specific heating ring.

In order to prepare a quotation, we require the following information:

- the bearing designation or ring dimensions
- a drawing of the mounting position including information on fits
- the approximate number of parts to be extracted per day.

Recommended accessories	<ul style="list-style-type: none"> ■ Electric heating plate HEATER-PLATE-370C ■ Temperature measuring device TEMP-CHECK-PLUS or TEMP-CHECK-PRO ■ Gloves GLOVE-PRO-CUT ■ Heat conducting paste HEATING-RING.PASTE-20ML.
Ordering example	Heating ring for the inner ring of a cylindrical roller bearing NU320-E, NJ320E and similar components
Ordering designation	20 ml heat conducting paste in expendable syringe HEATING-RING-320E
Further information	<ul style="list-style-type: none"> ■ For detailed information, see TPI 180, FAG Devices for Thermal Dismounting. ■ Enquiries: industrial-services@schaeffler.com, +49 2407 9149-66.
Heat conducting paste	
	The silicone-free heat conducting paste HEATING-RING.PASTE is used as an aid in the dismantling of bearing inner rings by means of heating rings.
	The cylindrical outside surface of the bearing inner ring is coated with the heat conducting paste before it is extracted. This gives optimum heat transfer.
Ordering example	20 ml heat conducting paste in expendable syringe
Ordering designation	HEATING-RING.PASTE-20ML
Further information	<ul style="list-style-type: none"> ■ For detailed information, see TPI 180, FAG Devices for Thermal Dismounting ■ Enquiries: industrial-services@schaeffler.com, +49 2407 9149-66.



Product overview Thermal mounting, induction heating devices

Tabletop devices

HEATER10



HEATER20



HEATER40

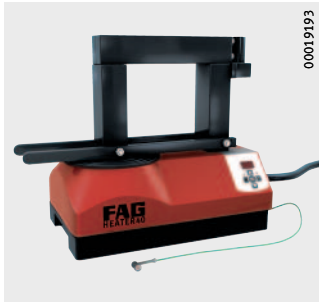

HEATER150

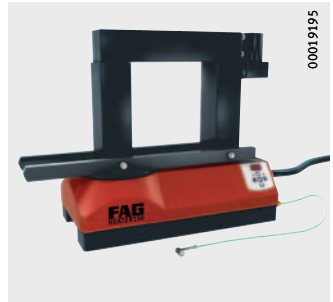

HEATER300

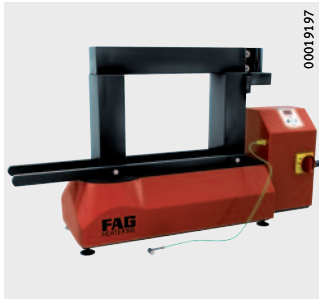

Standalone devices

HEATER600



00018A0A



HEATER1200



00018A0B

Thermal mounting, induction heating devices

Features

Induction heating devices HEATER with mains frequency technology are used to heat rolling bearings and other components with a cylindrical bore where a tight fit on the shaft or in the housing is intended.

Adequate expansion of the bearings is achieved in most cases at +80 °C to +100 °C. During the heating operation, the maximum heating temperature must be observed. The temperature of rolling bearings must not normally exceed +120 °C, in order to prevent changes to the structure and hardness of the bearing. In all devices for heating, the temperature can be steplessly controlled.



Wear protective gloves during mounting and dismantling of heated parts.

Induction heating devices HEATER

The induction heating devices HEATER for bearings up to a mass of 1 200 kg have been improved further in terms of their performance capability and safety compared with their predecessors. They can also be used to heat sealed and greased rolling bearings. In addition to the tabletop devices HEATER10 to HEATER300, the range also includes the standalone devices HEATER600 and HEATER1200 for larger rolling bearings. HEATER300 can also be converted to a mobile unit by means of accessories.

The scope of delivery of the induction heating devices HEATER covers a basic setup for the initial applications, *Figure 1*.

- ① Heating device
- ② Ledges
- ③ Temperature sensor
- ④ Remote control
- ⑤ Rolling bearing grease
- ⑥ Protective gloves
- ⑦ Cover
- ⑧ User manual

Figure 1
Scope of delivery:
Induction heating device HEATER



The rolling bearing to be heated is either suspended from the ledge or is placed horizontally on the support rails, *Figure 2*.



Figure 2
Heating a rolling bearing

Advantages of FAG heating devices

The advantages of induction heating devices are as follows:

- very safe operation
- high reliability (certified in accordance with the German inspection and certification body TÜV)
- effective, energy-efficient heating (high efficiency level)
- uniform, controlled heating
- automatic demagnetisation
- simple operation
- high cost-effectiveness through selection of the device size most suitable for the particular application.

The heating devices have various functions, see table.

Functions

Function	HEATER						
	10	20	40	150	300	600	1200
Demagnetisation	●	●	●	●	●	●	●
Program shutdown	●	●	●	●	●	●	●
Display of actual temperature value	●	●	●	●	●	●	●
Temperature display in °C or °F	●	●	●	●	●	●	●
Display of actual temperature value and time	–	–	●	●	●	●	●

● present

Thermal mounting, induction heating devices

Operating modes The induction heating devices can be operated in the following modes:

- temperature control
- time control (size HEATER40 and above)
- ramp control (size HEATER40 and above).

Function The principle of the heating device is based on a current-carrying coil with an iron core (primary coil), which generates a high induction current at low voltage in a short-circuited secondary circuit (rolling bearing or other steel part), *Figure 3*. As a result, the rolling bearing to be mounted is heated. Non-metallic components and the device itself remain cold.

- ① Primary coil
- ② Secondary circuit
- ③ U-shaped iron core
- ④ Slewing ledge
- ⑤ Electromagnetic field

Figure 3
Functional principle

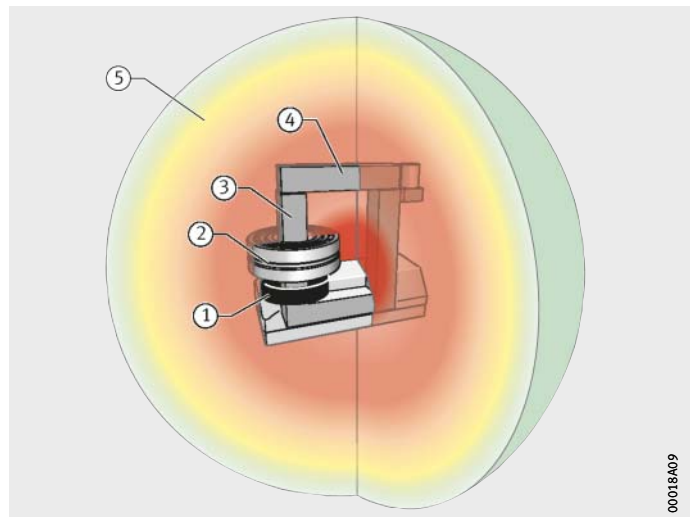

Further information

- For detailed information, see TPI 200, FAG Heating Devices for Mounting of Rolling Bearings.
- Enquiries: industrial-services@schaeffler.com, +49 2407 9149-66.

FAG Heating Manager

The software FAG Heating Manager is a user-friendly tool for selection of the optimum heating device for the heating of rolling bearings.

Once the rolling bearing to be heated has been selected, the bearing type, dimensions, mass and the suitable heating device are shown, *Figure 4*.

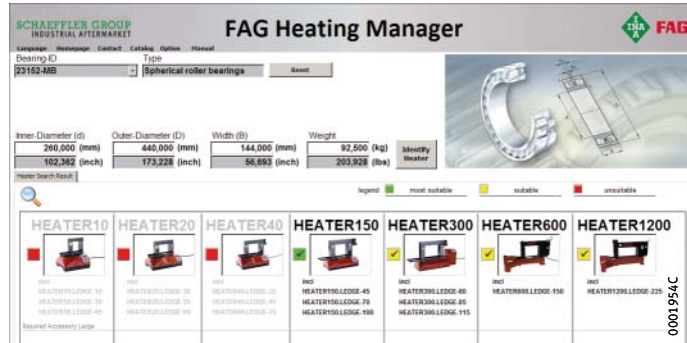
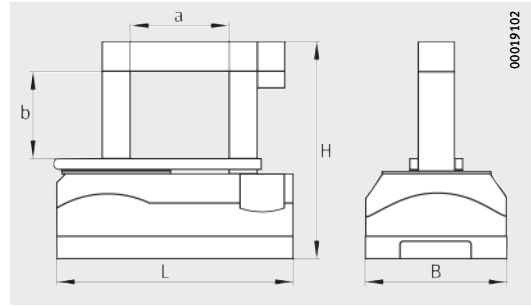

Figure 4
FAG Heating Manager

The FAG Heating Manager is available online at www.schaeffler.com under the menu Media Library.

Heating devices HEATER

Product range



Dimension table

Characteristics		Unit	HEATER10	HEATER20
				
Operating voltage	U	V	230	230
Frequency	F	Hz	50	50
Power consumption	P	kVA	2,3	3,6
Nominal current	I	A	10	16
Residual magnetism	H	A/cm	< 2	< 2
Duty cycle	ED	%	100	100
Mass	m	kg	7	14
Length	L	mm	240	345
Width	B	mm	200	205
Height	H	mm	255	230
Dimension	a	mm	65	120
Dimension	b	mm	100	100
Maximum rolling bearing mass	m	kg	10	20
Minimum rolling bearing bore (ledge)	d	mm	15	20
Minimum rolling bearing bore with accessories	d	mm	10	10
Minimum rolling bearing bore (lying flat)	d	mm	45	65
Maximum rolling bearing outside diameter	D	mm	165 (with LEDGE-45)	290 (with LEDGE-60)
Temperature control adjustable, with safety mechanism for rolling bearings	-	-	+40 °C to +240 °C	+40 °C to +240 °C
Time control	-	-	-	-
Ramp control	-	-	-	-





HEATER40	HEATER150	HEATER300	HEATER600	HEATER1200
				
230	400	400	400	400
50	50	50	50	50
3,6	12,8	12,8	25	40
16	25	32	63	100
< 2	< 2	< 2	< 2	< 2
100	100	100	100	100
26	57	75	350	850
420	500	1 045	1 300	1 660
240	290	310	820	1 040
295	480	570	1 080	1 250
180	210	330	430	700
160	210	265	400	450
40	150	300	600	1 200
20	45	60	150	225
15	20	30	55	95
80	110	125	–	–
410 (with LEDGE-70)	515 (with LEDGE-100)	740 (with LEDGE-115)	900 (with LEDGE-150)	1 500 (with LEDGE-225)
+40 °C to +240 °C	+40 °C to +240 °C	+40 °C to +240 °C	+40 °C to +240 °C	+40 °C to +240 °C
adjustable up to 99 min	adjustable up to 99 min	adjustable up to 99 min	adjustable up to 99 min	adjustable up to 99 min
adjustable up to 99 min and 240 °C	adjustable up to 99 min and 240 °C	adjustable up to 99 min and 240 °C	adjustable up to 99 min and 240 °C	adjustable up to 99 min and 240 °C

Heating devices HEATER

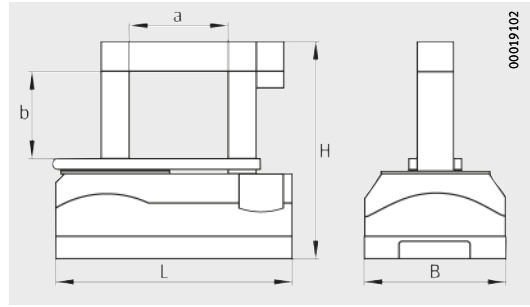
Product range



Dimension table

Characteristics		Unit	HEATER10-115V-UL	HEATER20-115V-UL
				
Operating voltage	U	V	115	115
Frequency	F	Hz	60	60
Power consumption	P	kVA	2,2	2,2
Nominal current	I	A	10	15
Residual magnetism	H	A/cm	< 2	< 2
Duty cycle	ED	%	100	100



HEATER40-115V-UL	HEATER150-460V-UL	HEATER300-460V-UL	HEATER600-460V-UL	HEATER1200-460V-UL
				
115	460	460	460	460
60	60	60	60	60
2,2	9,2	14,7	28,9	46
15	20	30	50	85
< 2	< 2	< 2	< 2	< 2
100	100	100	100	100

Product overview Thermal mounting and dismounting, medium frequency technology

Medium frequency devices

HEAT-GENERATOR, HEAT-INDUCTOR

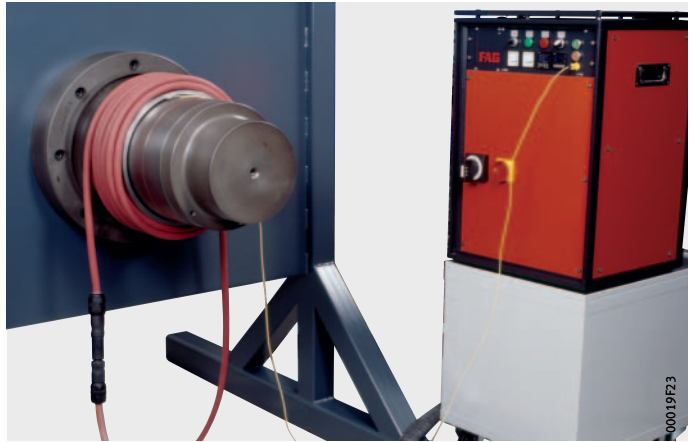

HEAT-GENERATOR, HEAT-INDUCTOR



Thermal mounting and dismantling, medium frequency technology

Features

Induction heating devices with medium frequency technology are used to heat rolling bearings and other components with a cylindrical bore where a tight fit on the shaft or in the housing is intended. Adequate expansion of the bearings is achieved in most cases at +80 °C to +100 °C. During the heating operation, the maximum heating temperature must be observed. The temperature of rolling bearings must not normally exceed +120 °C, in order to prevent changes to the structure and hardness of the bearing. In all devices for heating, the temperature can be steplessly controlled.



Wear protective gloves during mounting and dismantling of heated parts.

Induction units with medium frequency technology

The FAG heating device with medium frequency technology gives rapid, simple and effective heating of medium-sized to large rolling bearings and similar steel parts for mounting and dismantling. The device always comprises two parts: an inductor and a generator.

The inductor can be of a flexible design, *Figure 1*, or rigid design, *Figure 2*, page 64. The rigid design is particularly suitable for batch applications. The flexible design of inductor can be wound around the components, *Figure 1*. The flexible inductor can also be used with subframes, *Figure 3*, page 65, to rationalise repetitive work. Overall, this gives a wide range of applications, see table, page 64.

Each device is designed for the specific application and is fitted, depending on the workpiece, with flexible or rigid inductors. The necessary information can be seen in the table, page 65.

Due to its compact construction, the device can also be used for mobile operation. The device can therefore be moved to the location of the workpiece. It can therefore be used, for example, at construction sites for wind turbines or for other large components that are difficult to transport.



Figure 1

The flexible inductor can be wrapped around the component

Thermal mounting and dismounting, medium frequency technology



Figure 2
Rigid inductor
in the dismounting
of labyrinth rings

Versatile in application

Workpieces	
Inner rings of cylindrical roller bearings	Machine supports
Labyrinth rings	Gears
Couplings	Rotationally symmetrical steel parts
Ring rolls	Housings
Medium-sized to very large bearings	–

Advantages

The advantages of the heating device with medium frequency technology are as follows:

- suitable for mounting
- suitable for dismounting
- operating frequency from 10 kHz to 25 kHz
- efficiency of the generator higher than 90%
- low energy requirements
- short heating times
- control of heating according to time and temperature
- automatic demagnetisation
- flexible and fixed inductors available
- suitable for use either inside or outside component
- lower mains connection power than heating devices with mains frequency
- almost silent
- air-cooled system.

Figure 3
Rigid inductor
in the dismantling
of wheelset bearings



Application

Examples of the use of medium frequency technology include:

- heating of bearings for mounting and dismantling
- batch dismantling of bearing inner rings and labyrinth rings, for example in the case of wheelset bearings in rail vehicles, *Figure 2*, page 64
- dismantling of bearing inner rings from traction motors in rail vehicles
- heating of large components, for example bearings or bearing seats in wind turbines
- heating of roll rings and couplings, for example in steelworks
- loosening of shrink fit connections.

Data required in enquiries

Ordering information
Bearing dimensions, if possible with drawings
Representation of the adjacent construction
Data on the fit conditions
Description of the mounting process and its frequency
Power supply data
Ambient conditions
Your address

Further information

- For detailed information, see TPI 217, FAG Tools for Thermal Mounting and Dismounting, Medium Frequency Devices.
- Enquiries: industrial-services@schaeffler.com, +49 2407 9149-66.

Product overview Measurement and inspection

Feeler gauges Taper ring gauges

FEELER-GAUGE-100,
FEELER-GAUGE-300



KLR



Taper gauges

MGK133

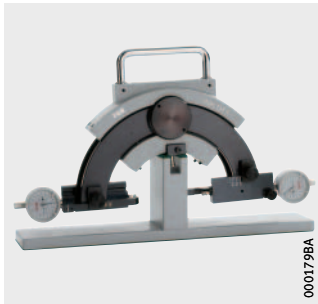

MGK132



Snap gauges

SNAP-GAUGE



Enveloping circle gauges

MGI21



MGA31



Measurement and inspection



Features Feeler gauges and measurement gauges can be used to inspect the production of bearing seats and the mounting of bearings.

Feeler gauges Feeler gauges FEELER-GAUGE, see table, are used to measure the radial internal clearance, especially in mounting on tapered shaft seats and on adapter and withdrawal sleeves.

Available feeler gauges

Designation	Feeler length mm	Feeler thickness		
		mm		
FEELER-GAUGE-100	100	0,03	0,08	0,14
		0,04	0,09	0,16
		0,05	0,1	0,18
		0,06	0,12	0,2
		0,07	–	–
FEELER-GAUGE-300	300	0,03	0,12	0,2
		0,04	0,13	0,25
		0,05	0,14	0,3
		0,06	0,15	0,35
		0,07	0,16	0,4
		0,08	0,17	0,45
		0,09	0,18	0,5
		0,1	0,19	–

Taper ring gauges and taper gauges These gauges are used to inspect tapered bearing seats in production facilities. This is necessary to ensure a good match between the fit surfaces of the bearing and bearing seat.

With the exception of taper ring gauges, gauges are available for different taper angles.

Taper ring gauges Taper ring gauges KLR are the simplest option for inspecting the bearing seat on small bearings. Inking is used to determine the matching of the ring gauge and bearing seat. The bearing seat is machined until the ring gauge is supported over its whole width. The inner rings of bearings are not suitable, since they can be damaged during inking.

Taper ring gauges are available in designs for taper diameters of 30 mm to 240 mm.

Ordering example Taper ring gauge for bearings with 100 mm bore and 37 mm taper length, for example double row cylindrical roller bearings NN3020-AS-K

Ordering designation **KLR-D100-L37**

Measurement and inspection

Taper gauge for tapers 1:12 and 1:30

The taper gauge MGK133 is used for the measurement of external tapers 1:12 and 1:30 with a taper diameter of 27 mm to 205 mm.

The reproducibility of the measurement results is less than 1 μm .

The gauge rests on the workpiece with four hardened and polished pins. The position of the gauge on the taper is defined by these pins and a stop. The stop can be attached to either the front or back of the gauge.

The gauge has two movable measuring brackets. One of these is in contact with the small taper diameter, the other with the large taper diameter. There is a fixed spacing between the measuring brackets. The deviation of the taper diameter from the nominal value is displayed in both measurement planes by a precision indicator.

The gauge is set using a reference taper (available by agreement).

Ordering designation

Available by agreement

Taper gauge for taper angle 0° to 6°

The taper gauge MGK132 is used for the measurement of external tapers with a taper angle of 0° to 6° and a taper diameter of 90 mm to 360 mm.

The reproducibility of the measurement results is less than 1 μm .

The gauge rests on the workpiece with four hardened, ground and lapped ledges. The ledges form an angle of 90°. The position of the gauge on the taper is defined by a stop on the front or back of the gauge.

The measurement slide runs between the support ledges.

A dial gauge in the housing acts against the measurement slide and displays the deviation of the taper diameter from the nominal value.

The deviation of the taper from the nominal value is displayed by a precision indicator on the measurement slide.

The gauge is set using a reference taper (available by agreement).

Ordering designation

Available by agreement

Snap gauges

Snap gauges SNAP-GAUGE, see table, can be used to inspect the diameter of cylindrical workpieces directly on the machine tool. The snap gauge is also used to set the enveloping circle gauge MGI21. The snap gauge functions as a comparator gauge. It is set using shims. The deviation from the set value can then be determined.



Available snap gauges

Designation	Diameter range	
	min. mm	max. mm
SNAP-GAUGE-30/60	30	60
SNAP-GAUGE-60/100	60	100
SNAP-GAUGE-100/150	100	150
SNAP-GAUGE-150/200	150	200
SNAP-GAUGE-200/250	200	250
SNAP-GAUGE-250/300	250	300

Shims for numerous diameters are available as accessories.

Ordering example	Snap gauge for shaft diameter 120 mm
Ordering designation	SNAP-GAUGE-100/150
Ordering example	Shim for shaft diameter 120 mm
Ordering designation	SNAP-GAUGE.MASTER120

Measurement and inspection

Enveloping circle gauges

Enveloping circle gauges, see table, can be used to set the radial internal clearance or preload of cylindrical roller bearings.

Available enveloping circle gauges

Designation	Type	For bearings	
		from	to
MGI21	For cylindrical roller bearings with separable inner ring	NNU4920-K	NNU4948-K
		NNU4920	NNU4948
MGA31	For cylindrical roller bearings with separable outer ring	NN3006-K	NNU3048-K
		N1006-K	N1048-K

Bearings with separable inner rings

The enveloping circle gauge MGI21 is used to measure, by means of two hardened and precision ground surfaces, the internal enveloping circle of a roller and cage assembly. One measurement surface is movable.

Before measurement, the gauge is set to the internal enveloping circle of the roller and cage assembly. This setting operation requires a snap gauge such as SNAP-GAUGE.

After mounting of the outer ring together with the roller and cage assembly, the enveloping circle diameter is then determined using the gauge MGI in a comparative measurement.

In the case of a bearing with a tapered bore, the enveloping circle measurement is used to calculate its position on the tapered seat of the shaft. During mounting, the bearing is driven to this position. This results in the internal clearance or the preload.

In the case of bearings with a cylindrical bore, preground inner rings (suffix F12) are used and finish ground to the required bearing diameter.

Ordering example
Ordering designation

Enveloping circle gauge for cylindrical roller bearing NNU4920
MGI21-NNU4920

Bearings with separable outer rings

The enveloping circle gauge MGA31 is used to measure, by means of two hardened and precision ground surfaces, the external enveloping circle of the roller and cage assembly.

The gauge is set to the raceway diameter of the mounted outer ring. This dimension is determined using a conventional internal gauge.

The tapered shaft with the premounted inner ring and roller and cage assembly is then inserted in the gauge. The shaft is driven axially by the hydraulic method until the required radial internal clearance or preload is achieved.

Ordering example
Ordering designation

Enveloping circle gauge for cylindrical roller bearing NN3006-K
MGA31-NN3006



Product overview Accessories

Transport and mounting tool

BEARING-MATE



Gloves

GLOVE-PRO, GLOVE-PRO-CUT, GLOVE-PRO-TEMP



Mounting paste

ARCANOL-MOUNTINGPASTE



Anti-corrosion oil

ARCANOL-ANTICORROSIONOIL



Accessories

Features Accessories are used to assist in the storage, transport and mounting of rolling bearings.



Transport and mounting tool

The transport and mounting tool BEARING-MATE, see table, is an accessory for the easy handling of medium-sized and large rolling bearings. It can also be used in the heating of bearings prior to mounting.

The tool comprises two handles and two steel strips. The steel strips are tightly clamped on the outer ring of the bearing. During transport of spherical roller bearings and self-aligning ball bearings, tilting of the inner rings is prevented by the brackets supplied.

The bearing together with the tool is carried by either two people or by means of a crane. While it is being transported by crane, the bearing is suspended by the tool using the carrying slings and can be rotated into any position required.

The bearing can remain in the tool during heating. It expands to the same extent as the bearing.

The tool can be used for bearings up to a mass of 500 kg and at temperatures up to +160 °C.

Available tools

Designation	Bearing outside diameter mm		Mass of tool kg
	over	incl.	
BEARING-MATE250-450	250	450	6,3
BEARING-MATE450-650	450	650	6,4
BEARING-MATE650-850	650	850	6,5

Ordering example Transport and mounting tool for bearings with outside diameter from 250 mm to 450 mm using 2 short brackets and a pair of gloves GLOVE-PRO-CUT

Ordering designation **BEARING-MATE250-450**

Accessories

Accessories, brackets	2 long brackets to prevent tilting of the inner rings of spherical roller bearings
Ordering designation	BEARING-MATE-LOCKBAR270
Accessories, carrying slings	2 carrying slings, 1 m long
Ordering designation	BEARING-MATE.SLING-1M
Accessories, pack of small parts	Pack of small parts
Ordering designation	BEARING-MATE.SERVICE-KIT
Gloves	The heat-resistant gloves are particularly suitable for the handling of heated rolling bearings or other heated components in mounting and dismounting. The gloves are cut-resistant and durable.
Resistant up to +150 °C	Gloves GLOVE-PRO are resistant up to +150 °C.
Ordering designation	GLOVE-PRO
Resistant up to +200 °C	If the main priority is protection of hands against high temperatures, the heat-insulating gloves GLOVE-PRO-TEMP are suitable. They comprise several layers, are cotton-free, oil-resistant and suitable for temperatures up to +200 °C. The gloves are non-flammable and are also heat-resistant even when damp. They are authorised in accordance with DIN EN 388 for mechanical influences and in accordance with DIN EN 407 for thermal influences.
Ordering designation	GLOVE-PRO-TEMP
Resistant up to +250 °C, highly resistant to cutting	If the main priority is not only good protection against high temperatures but also protection against burrs and edges, the particularly cut-resistant gloves GLOVE-PRO-CUT are suitable. They comprise several layers, are oil-resistant and suitable for temperatures up to +250 °C. The gloves are non-flammable and are also heat-resistant even when damp. They are authorised in accordance with DIN EN 388 for mechanical influences and in accordance with DIN EN 407 for thermal influences.
Ordering designation	GLOVE-PRO-CUT

Mounting paste

The mounting paste, see table, facilitates the sliding of bearing rings and prevents stick/slip effects, scoring, wear and fretting corrosion. It also gives protection against corrosion.

The operating temperature range is between $-30\text{ }^{\circ}\text{C}$ and $+150\text{ }^{\circ}\text{C}$.

The paste is resistant to water, water vapour and many alkaline and acidic media.



Available mounting pastes

Designation	Container
ARCANOL-MOUNTINGPASTE-70G	Tube containing 70 g
ARCANOL-MOUNTINGPASTE-250G	Tube containing 250 g
ARCANOL-MOUNTINGPASTE-400G	Cartridge containing 400 g
ARCANOL-MOUNTINGPASTE-1KG	Can containing 1 kg

Anti-corrosion oil

This oil gives protection of bearings that have been unpacked. It also gives long term protection against corrosion of bright metallic surfaces, for example on devices and machinery, during storage indoors.

In general, it is not necessary to wash the anti-corrosion oil out of rolling bearings. It gives neutral behaviour towards conventional rolling bearing greases and oils.

The oil can be removed using alkaline solvents or neutral cleaning agents.

Ordering example

Spray can containing 0,4 l

Ordering designation

ARCANOL-ANTICORROSIONOIL-400G

FAG



Products: Lubrication

Products: Lubrication

	Page
Lubricants	
Matrix	
Multipurpose greases	80
Greases for high loads	80
Greases for wide temperature ranges	82
Special greases	82
Features	
Rolling bearing greases Arcanol.....	84
Lubrication devices	
Product overview	86
Features	
Automatic relubrication devices	88
Pistol grease guns.....	92
Service pump for wind turbines	92
Grease pumps.....	93



Multipurpose greases

Designation	Thickener	Base oil	Base oil viscosity at +40 °C mm ² /s	Consistency NLGI	Operating temperature °C	
					from	to
MULTIOP	Lithium soap	Partially synthetic oil	82	2	-50 ¹⁾	+140
MULTI2	Lithium soap	Mineral oil	110	2	-30	+120
MULTI3	Lithium soap	Mineral oil	110	3	-20	+120

Definition of symbols
 ++ extremely suitable
 + highly suitable
 o suitable
 – less suitable
 -- not suitable

Greases for high loads

Designation	Thickener	Base oil	Base oil viscosity at +40 °C mm ² /s	Consistency NLGI	Operating temperature °C	
					from	to
LOAD150	Lithium complex soap	Mineral oil	160	2	-20	+140
LOAD220	Lithium/calcium soap	Mineral oil	245	1 – 2	-20	+140
LOAD400	Lithium/calcium soap	Mineral oil	400	2	-30 ¹⁾	+130
LOAD460	Lithium/calcium soap	Mineral oil	400	1	-30 ¹⁾	+130
LOAD1000	Lithium/calcium soap	Mineral oil	1 000	2	-20	+130

Definition of symbols
 ++ extremely suitable
 + highly suitable
 o suitable
 – less suitable
 -- not suitable

¹⁾ Measurement values according to Schaeffler FE8 low temperature test.

Continuous limit temperature °C	Characteristic applications	Temperatures		Low friction, high speed	High load, low speed	Vibrations	Support for seals	Relubrication facility
		Low	High					
+85	Ball and roller bearings in rolling mills, construction machinery, automotive engineering, spinning and grinding spindles	++	+	+	++	+	o	++
+75	Ball bearings up to 62 mm diameter in small electric motors, agricultural and construction machinery, household appliances	+	o	o	o	o	o	++
+75	Ball bearings from 62 mm diameter in large electric motors, agricultural and construction machinery, ventilators	+	o	o	o	+	+	+

Continuous limit temperature °C	Characteristic applications	Temperatures		Low friction, high speed	High load, low speed	Vibrations	Support for seals	Relubrication facility
		Low	High					
+90	Ball, roller and needle roller bearings, linear guidance systems in machine tools	o	+	-	++	+	+	+
+80	Ball and roller bearings in rolling mills, rail vehicles, paper machinery	o	o	-	++	+	+	+
+80	Ball and roller bearings in mining machinery, construction machinery, main bearings for wind turbines	o	o	-	++	+	+	+
+80	Ball and roller bearings, wind turbines, bearings with pin-type cage	+	o	-	++	+	-	+
+80	Ball and roller bearings in mining machinery, construction machinery, cement plant	o	o	--	++	+	+	+



Greases for wide temperature ranges

Definition of symbols
 ++ extremely suitable
 + highly suitable
 o suitable
 – less suitable
 -- not suitable

Designation	Thickener	Base oil	Base oil viscosity at +40 °C mm ² /s	Consistency NLGI	Operating temperature	
					°C	
					from	to
TEMP90	Poly-carbamide	Partially synthetic oil	148	3	-40	+160
TEMP110	Lithium complex soap	Partially synthetic oil	130	2	-40	+160
TEMP120	Poly-carbamide	Partially synthetic oil	400	2	-30	+180
TEMP200	PTFE	Fluoridated polyether oil	550	2	-30	+250

Special greases

Definition of symbols
 ++ extremely suitable
 + highly suitable
 o suitable
 – less suitable
 -- not suitable

Designation	Thickener	Base oil	Base oil viscosity at +40 °C mm ² /s	Consistency NLGI	Operating temperature	
					°C	
					from	to
SPEED2,6	Lithium complex soap	Synthetic oil	25	2 – 3	-40	+120
VIB3	Lithium complex soap	Mineral oil	170	3	-30	+150
BIO2	Lithium/calcium soap	Synthetic oil	55	2	-30	+120
FOOD2	Aluminium complex soap	Synthetic oil	150	2	-30	+120
CLEAN-M	Poly-carbamide	Ester	103	2	-30	+180
MOTION2	Lithium soap	Synthetic oil	50	2	-40	+130

Continuous limit temperature °C	Characteristic applications	Temperatures		Low friction, high speed	High load, low speed	Vibrations	Support for seals	Relubrication facility
		Low	High					
+90	Ball and roller bearings in couplings, electric motors, automotive engineering	++	+	o	o	o	+	+
+110	Ball and roller bearings in electrical equipment, automotive engineering	++	++	+	o	o	o	o
+120	Ball and roller bearings in continuous casting plant, paper machinery	+	++	-	++	o	+	o
+200	Ball and roller bearings in guide rollers in baking machinery, kiln trucks and chemical plant, piston pins in compressors	+	++	---	+	o	o	o

Continuous limit temperature °C	Characteristic applications	Temperatures		Low friction, high speed	High load, low speed	Vibrations	Support for seals	Relubrication facility
		Low	High					
+70	Ball bearings in machine tools, spindle bearings, rotary table bearings, instrument bearings	++	o	++	--	-	o	o
+90	Ball and roller bearings in blade adjusters in wind turbine rotors, packaging machinery, rail vehicles	+	+	-	+	++	+	-
+80	Ball and roller bearings in environmentally hazardous applications	o	o	o	o	o	o	++
+70	Ball and roller bearings in applications with food contact (NSF-H1 registration, kosher and halal certification)	+	-	o	o	o	o	++
+90	Ball, roller and needle roller bearings as well as linear guidance systems in clean room applications	++	++	o	o	o	o	+
+70	Ball and roller bearings in oscillating operation, slewing rings in wind turbines	++	o	-	+	++	+	o



Lubricants

Features

The lubricants available from Schaeffler are designed and tested for bearing arrangement engineering.

Rolling bearing greases Arcanol

The Arcanol rolling bearing greases offer very good preconditions for favourable running behaviour of bearings and a long operating life and high operational security of the bearing arrangement. The lubricant range is graduated such that almost all areas of application are covered.

The areas of application of Arcanol greases were determined under widely differing operating conditions and with rolling bearings of all types by means of modern testing methods and testing systems. Arcanol rolling bearing greases have superior characteristics in all areas compared to normal greases, *Figure 1*.

L = rating life
n = speed
R = mixed friction
t = lubrication interval

① Normal grease

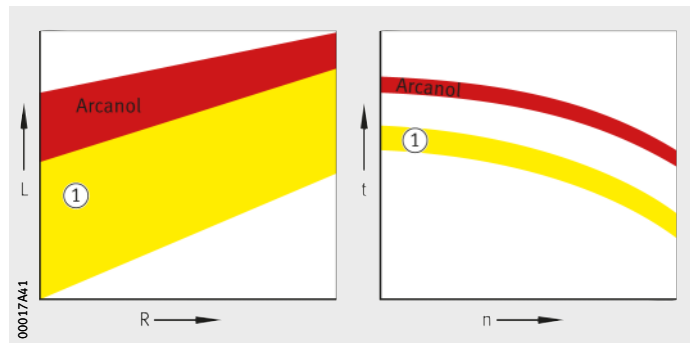

Figure 1
Characteristics of lubricants

Grease container sizes

Arcanol grease ¹⁾	Tube		Cartridge 400 g	Can 1 kg
	70 g	250 g		
MULTITOP	–	●	●	●
MULTI2	–	●	●	●
MULTI3	–	●	●	●
LOAD150	–	–	●	●
LOAD220	–	–	●	●
LOAD400	–	–	●	●
LOAD460	–	–	●	●
LOAD1000	–	–	–	–
TEMP90	–	–	●	●
TEMP110	–	–	●	●
TEMP120	–	–	–	●
TEMP200	●	–	–	●
SPEED2,6	–	●	●	●
VIB3	–	–	●	●
BIO2	–	–	●	●
FOOD2	–	–	●	●
MOTION2	–	–	●	●
MOUNTINGPASTE	●	●	●	●

¹⁾ Other containers are available by agreement.

Grease container sizes (continued)

Arcanol grease ¹⁾	Bucket			Hobcock		Drum 180 kg
	5 kg	12,5 kg	15 kg	25 kg	50 kg	
MULTITOP	●	●	–	●	–	●
MULTI2	●	●	–	●	–	●
MULTI3	●	●	–	●	–	●
LOAD150	–	●	–	–	●	–
LOAD220	–	●	–	●	–	●
LOAD400	●	●	–	●	●	●
LOAD460	●	●	–	●	●	●
LOAD1000	●	–	–	●	●	●
TEMP90	●	–	–	●	–	●
TEMP110	–	–	–	–	●	–
TEMP120	●	–	–	●	–	–
TEMP200	–	–	–	–	–	–
SPEED2,6	–	–	–	●	–	–
VIB3	–	–	–	●	●	–
BIO2	–	●	–	●	–	–
FOOD2	●	●	●	●	●	●
MOTION2	●	●	–	●	●	●
MOUNTINGPASTE	–	–	–	–	–	–

¹⁾ Other containers are available by agreement.

Further information

- For detailed information, see TPI 168, Arcanol Rolling Bearing Greases.
- Enquiries: industrial-services@schaeffler.com, +49 2407 9149-66.

Product overview Lubrication devices

Lubricator

CONCEPT2



Lubrication system

CONCEPT8



Pistol grease guns

ARCA-PUMP-BARREL.GUN-METER



Service pumps for wind turbines

ARCA-PUMP-WIND-SERVICE-KIT



Grease pumps

Grease dispensing units

Drum pumps

ARCA-PUMP



ARCA-PUMP-BARREL

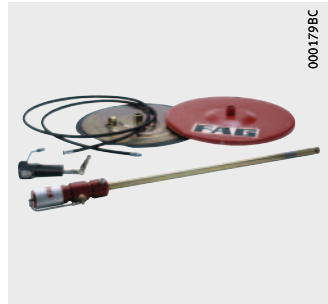

Lever grease guns

ARCA-GREASE-GUN



Lubrication devices

Features Rolling bearings are automatically provided with the correct quantity of lubricant by lubricators and lubrication systems. This prevents the most frequent cause of rolling bearing failure: inadequate or incorrect lubrication. Approximately 90% of bearings are lubricated with grease. Relubrication with the correct quantity of grease at the appropriate intervals gives a significant increase in the life of rolling bearings. For manual relubrication, grease guns are suitable.

Automatic relubrication devices

Automatic relubrication devices convey fresh lubricant in the defined quantity at the correct time to the contact points of the rolling bearing. The devices adhere to the lubrication and maintenance intervals and prevent undersupply or oversupply of grease. Plant downtime and maintenance costs are reduced as a result.

The relubrication devices are matched to the bearing positions. They have a wide range of applications, for example on electric motors, gearboxes, pumps, compressors and fans, in linear systems, conveying equipment, machine tools etc.

Lubricator CONCEPT2

This lubricator from protection class IP65 has a very compact design. It has one or two pump bodies that can be individually controlled, depending on the design. This means it can supply one or two lubrication points with lubricant. LC units are available in the size 250 cm³. The lubricator is supplied with voltage either from a battery or via a mains power pack. It can work independently or can be optionally controlled by an external control system.

Advantages

The advantages of the lubricator are as follows:

- supply of up to two lubrication points
- supply of set lubricant quantity independent of temperature
- reliable piston pump as delivery pump
- reduced personnel costs compared to manual relubrication
- favourable price/performance ratio
- operating temperature from -20 °C to +70 °C
- different lubrication intervals can be set for each lubrication point
- battery or mains operation (DC 24 V) possible
- pressure build-up to 50 bar
- coupling with machine operation possible
- can be controlled via an external control system.

**Available lubrication systems
CONCEPT2**

Designation	Design
CONCEPT2-1P	Battery version with one outlet
CONCEPT2-2P	Battery version with two outlets
CONCEPT2-1P-24VDC	24 V version with one outlet
CONCEPT2-2P-24VDC	24 V version with two outlets

Available LC units

Designation	
ARCALUB-C2.LC250-MULTITOP	ARCALUB-C2.LC250-TEMP90
ARCALUB-C2.LC250-MULTI2	ARCALUB-C2.LC250-TEMP110
ARCALUB-C2.LC250-LOAD150	ARCALUB-C2.LC250-TEMP120
ARCALUB-C2.LC250-LOAD220	ARCALUB-C2.LC250-TEMP200
ARCALUB-C2.LC250-LOAD400	ARCALUB-C2.LC250-SPEED2,6
ARCALUB-C2.LC250-LOAD460	ARCALUB-C2.LC250-BIO2
ARCALUB-C2.LC250-LOAD1000	ARCALUB-C2.LC250-FOOD2
–	ARCALUB-C2.LC250-CLEAN-M

Further information

- LC units are also available by agreement with other greases



Lubrication devices

Lubrication system CONCEPT8

This single-point and multi-point lubrication system offers high flexibility. It has one, two, three or four pump bodies that can be individually controlled, depending on the design. Each pump body has two outlets and, as a result, up to eight lubrication points can be flexibly provided with the required quantity of lubricant in the correct lubrication interval using just one lubrication system.

The lubrication system CONCEPT8 is designed for a wide variety of operating conditions. Designs for linear systems, the use of oils as lubricant or with an internal heating facility are also available. Lubricant cartridges (LC units) provide the device with lubricant. LC units are available in the size 800 cm³.

The lubrication system is supplied with voltage from a mains power pack. Coupling with machine operation is possible. If the voltage supply to machine and lubrication system is coupled, then the relubrication interval will always be dependent on the number of operating hours.

Advantages

The advantages of the lubrication system are as follows:

- suitable for oil and grease up to NLGI 3
- supply of up to eight lubrication points
- supply of set lubricant quantity independent of temperature
- reliable piston pump as delivery pump
- reduced personnel costs compared to manual relubrication
- favourable price/performance ratio
- operating temperature from -20 °C to +70 °C
- individual lubrication intervals and lubricant quantities can be set
- low operating voltage of DC 24 V
- pressure build-up to 70 bar
- coupling with machine operation possible
- can be controlled via an external control system.

**Available lubrication systems
CONCEPT8**

Designation	
CONCEPT8-1P	CONCEPT8-1P-CC
CONCEPT8-2P	CONCEPT8-2P-CC
CONCEPT8-3P	CONCEPT8-3P-CC
CONCEPT8-4P	CONCEPT8-4P-CC
CONCEPT8-1P-LIN	CONCEPT8-1P-OIL
CONCEPT8-2P-LIN	CONCEPT8-2P-OIL
CONCEPT8-3P-LIN	CONCEPT8-3P-OIL
CONCEPT8-4P-LIN	CONCEPT8-4P-OIL

LIN = for linear applications
 CC = with internal heating facility
 OIL = oil version

Available LC units

Designation	
ARCALUB-C8.LC800-MULTITOP	ARCALUB-C8.LC800-TEMP90
ARCALUB-C8.LC800-MULTI2	ARCALUB-C8.LC800-TEMP110
ARCALUB-C8.LC800-MULTI3	ARCALUB-C8.LC800-TEMP120
ARCALUB-C8.LC800-LOAD150	ARCALUB-C8.LC800-TEMP200
ARCALUB-C8.LC800-LOAD220	ARCALUB-C8.LC800-SPEED2,6
ARCALUB-C8.LC800-LOAD400	ARCALUB-C8.LC800-VIB3
ARCALUB-C8.LC800-LOAD460	ARCALUB-C8.LC800-BIO2
ARCALUB-C8.LC800-LOAD1000	ARCALUB-C8.LC800-FOOD2
–	ARCALUB-C8.LC800-CLEAN-M

Further information

- LC units are also available by agreement with other greases or with oils
- Other accessories available by agreement
- Enquiries: industrial-services@schaeffler.com, +49 2407 9149-66.

Lubrication devices

Pistol grease guns

Pistol grease guns have a 4 digit digital counter that displays the lubricant quantity in grams. The specific mass of the lubricant can be set.

Ordering designation

ARCA-PUMP-BARREL.GUN-METER

Service pumps for wind turbines

These service pumps, see table, are particularly suitable for the relubrication of bearings in wind turbines. They comprise a rigid frame with rollers, an electrically driven grease pump, a holder for the grease container and a pistol grease gun with a 4 m long hose.

A hook and eye on the frame can be used to transport the service pump securely into the nacelle. The rollers, one of which can be anchored, can be used to move the device within the nacelle.

The service pump can be used at temperatures from +10 °C to +40 °C. It can be filled with the greases Arcanol LOAD400, LOAD460 and MULTITOP in 12,5 kg buckets.

Available service pumps for wind turbines

Designation	Maximum delivery pressure bar	Delivery rate cm ³ /min
ARCA-PUMP-WIND-SERVICE-KIT	200	280

Grease pumps Grease pumps are driven by pneumatic, electrical or manual means.

Grease dispensing units Grease dispensing units ARCA-PUMP, see table, are used for the metered greasing of rolling bearings. The metering range is between 10 cm³ and 133 cm³ per stroke. Larger metering ranges can also be achieved by operating the devices several times. By means of a pneumatically driven, double direction piston pump, the medium is conveyed directly from the grease container (25 kg or 180 kg) via the metering valve to the application point.

A grease dispensing unit comprises a:

- cover
- piston
- metering valve
- hose connecting the pump and valve
- hose, 2,5 m long
- metering pistol.

Available grease dispensing units

Designation	Pump ratio	Delivery rate cm ³ /min	Metering range		Suitable for container sizes kg
			min. cm ³	max. cm ³	
ARCA-PUMP-25	10:1	400	10	133	25
ARCA-PUMP-180	10:1	400	10	133	180



Drum pumps Drum pumps ARCA-PUMP-BARREL, see table, are pneumatically driven and suitable for delivering large quantities of grease under high pressure over long distances. Drum pumps can be used either as delivery pumps for individual greasing stations or as a supply pump for central lubrication systems.

Available drum pumps

Designation	Pump ratio	Delivery rate at 6 bar g/min	Air consumption l/min	Suitable for container sizes kg
ARCA-PUMP-BARREL-25-S	70:1	1 100	150	25
ARCA-PUMP-BARREL-50-S	70:1	1 100	150	50
ARCA-PUMP-BARREL-180-S	70:1	1 100	150	180

The following accessories are available for the drum pumps: drum cover (dust cover), follower plate, high pressure delivery hoses and pistol grease guns.

Lubrication devices

Lever grease gun and reinforced hose

The lever grease gun, see table, can be used to manually relubricate rolling bearings via lubrication nipples.

The container on the lever grease gun can be filled with 500 g loose grease or with a 400-g cartridge. The cartridge must conform to DIN 1284 (diameter 53,5 mm, length 235 mm).

The lever grease gun is connected to the lubrication nipple via a reinforced hose. The reinforced hose must be ordered separately, see table. The connector thread is G^{1/8}. The reinforced hose has a hydraulic grip coupling for connection to the taper type lubrication nipple in accordance with DIN 71412.

Alternatively, the reinforced hose can be fitted with a connector for cylindrical lubrication nipples in accordance with DIN 3404.

In place of the hydraulic grip coupling, slide couplings for button head lubrication nipples in accordance with DIN 3404 or other nozzles can be connected. These connectors are available from normal trade outlets.

Available lever grease guns

Designation	Maximum delivery pressure bar	Delivery quantity per stroke cm ³
ARCA-GREASE-GUN	800	2

Available reinforced hoses

Designation	Length mm	Connector
ARCA-GREASE-GUN.HOOK-ON-HOSE	300	Cylindrical lubrication nipple with head 16 mm to DIN 3404
ARCA-GREASE-GUN.HOSE	300	Taper type lubrication nipple to DIN 71412



Products: Condition monitoring



Products: Condition monitoring

		Page
Alignment	Product overview	98
	Features	
	Belt pulley alignment device Top-Laser SMARTY2.....	99
	Belt tension measuring device Top-Laser TRUMMY2.....	101
	Shaft alignment device Top-Laser EQUILIGN.....	103
	Shims Top-Laser SHIM	108
Checking the operating condition	Product overview	110
	Features	
	Infrared thermometer TempCheck PLUS.....	111
	Infrared thermometer TempCheck PRO	112
	Digital hand tachometer FAG TACHOMETER.....	114
	Sonar device SOUND-CHECK.....	115
Vibration diagnosis	Product overview	116
	Features	
	Monitoring devices – offline and online.....	117
	Worldwide service.....	117
	Vibration measuring device Detector III	117
	Online monitoring system SmartCheck	120
	Online monitoring system DTECT X1 _s	121
	Online monitoring system WiPro _s	122
	Online monitoring system ProCheck	123
	Other online monitoring systems.....	123
Monitoring of components	Product overview	124
	Features	
	Online monitoring system ProTorq	125
Monitoring of lubricants	Product overview	126
	Features	
	Grease sensor GreaseCheck	127
	Oil sensor Wear Debris Check.....	128



Product overview Alignment

Belt pulley alignment device
Top-Laser SMARTY2
Belt tension measuring device
Top-Laser TRUMMY2

LASER-SMARTY2



LASER-TRUMMY2



Shaft alignment device
Top-Laser EQUILIGN
Shims
Top-Laser SHIM

LASER-EQUILIGN



LASER-SHIM



Alignment

Features These products assist in the alignment of shafts and belt pulleys and the checking of belt tension.

Belt pulley alignment device FAG Top-Laser SMARTY2

FAG Top-Laser SMARTY2 is a line laser for the alignment of belt pulleys and chain sprockets with a diameter larger than 60 mm. Alignment of belt pulleys and chain sprockets reduces wear and energy losses in traction drives and the associated bearings and seals. Less heat is generated and the running time and reliability of the machinery is increased.

The features of the line laser are as follows:

- The parallelism and misalignment of both pulleys are displayed.
- Both horizontally and vertically mounted belt pulleys can be aligned.
- Alignment is significantly quicker and more precise than with conventional methods.
- Only one person is required for alignment.
- The measuring device adheres by magnetism to the pulleys.

The laser beam can be clearly seen on the target marks. Once the laser beam is adjusted to coincide with the slots in the target marks, the machine is correctly aligned.

The target marks are available in optical and electronic versions, *Figure 1*. In the case of electronic target marks, the adjustment values are shown in the digital display in real time. Misalignments are presented in degrees, the parallelism offset is presented in mm.

Caution 

Do not look into the laser beam or point the laser beam into another person's eyes.



Figure 1
Electronic target mark

000192A8

Alignment

All the parts are supplied in a lined case, *Figure 2*.

Scope of delivery	1 transmitter 2 optical target marks, attached by magnetism 1 battery 1 lined case
Ordering designation	LASER-SMARTY2

- ① Transmitter
- ② Optical target mark
- ③ Battery
- ④ Lined case

Figure 2
Scope of delivery
FAG Top-Laser SMARTY2



Spare parts	1 optical target mark, attached by magnetism
Ordering designation	LASER-SMARTY2.TARGET
Accessories	1 electronic target mark, attached by magnetism 1 case
Ordering designation	LASER-SMARTY2.TARGET-DIGITAL

**Belt tension measuring device
FAG Top-Laser TRUMMY2**

The robust, handy FAG Top-Laser TRUMMY2 is an optical-electronic manual measuring instrument for belt tension (strand force).

The correct belt tension is an essential prerequisite for achieving the maximum life of the belt drive. In addition, this also gives reduced wear of the drive components, lower energy costs and increased cost-efficiency.

The FAG Top-Laser TRUMMY2 comprises a cableless measurement probe for direct connection, a measurement probe with cable for difficult to access locations and a manual control device that displays the relevant measurables for belt tension as a frequency in Hz or force in N.

Caution 

Do not look into the laser beam or point the laser beam into another person's eyes.

The simple and reliable user menu is given in several languages.

All the parts of the belt tension measuring device are supplied packed in a case, *Figure 3*.

Scope of delivery

- 1 manual control device
- 1 measurement probe for direct connection
- 1 measurement probe with cable
- 1 case

Ordering designation

LASER-TRUMMY2

- ① Manual control device
- ② Measurement probe, direct connection
- ③ Measurement probe, cable connection
- ④ Case

Figure 3
Scope of delivery
FAG Top-Laser TRUMMY2



The belt tension measuring device should be calibrated at least every 2 years. The FAG Top-Laser TRUMMY2 should be sent to us for this purpose.

Service
Ordering designation

Calibration
LASER-TRUMMY.CALI-CHECK

Alignment

Application Before calculating the belt tension, the belt mass and length must be entered. Vibration of the belt is then induced. The device measures the natural frequency by means of clock pulse light and uses this to determine the belt tension, *Figure 4*. This technique is less prone to disruptive influences in comparison with measurement sound waves.



- ① Belt
- ② TRUMMY2, cableless measurement probe

Figure 4
Measurement

Shaft alignment device FAG Top-Laser EQUILIGN

The FAG Top-Laser EQUILIGN, *Figure 5*, is an alignment system for coupled and decoupled shafts in motors, pumps, ventilators and gearboxes with rolling bearings.

The advantages of the system are as follows:

- simple mounting
- error-free handling even by untrained personnel using step-by-step display on the manual control device
- automatic tolerance checking.
A symbol indicates when the shafts are correctly aligned.
- more precise alignment than with conventional methods
- rapid, simple measurement by means of Active Clock measurement mode
- robust control device.
Watertight and insensitive to contamination in accordance with IP 65
- user interface in 20 languages
- easy generation of reports
- real time display of displacement in all axes.

Caution 

Do not look into the laser beam or point the laser beam into another person's eyes.



Figure 5
Shaft alignment device
FAG Top-Laser EQUILIGN

Alignment

All the parts of the shaft alignment device are supplied packed in a case, *Figure 6*.

- Scope of delivery
- 1 manual control device
 - 1 transmitter and receiver including cable 2 m long
 - 1 reflector
 - 5 batteries
 - 1 Allen key
 - 1 cable for connecting USB memory stick to device
 - 1 cable for connecting device to PC via USB port
 - 2 brackets
 - 2 chains, 300 mm long
 - 4 posts, 115 mm long
 - 1 tape measure
 - 1 case

Ordering designation **LASER-EQUILIGN**

- ① Manual control device
- ② Transmitter/receiver
- ③ Reflector
- ④ Batteries, LR6 (AA) DC 1,5 V, 5 pieces
- ⑤ Allen key, 4 mm
- ⑥ Cable for USB memory stick
- ⑦ Cable for PC
- ⑧ Bracket
- ⑨ Chain, 300 mm long
- ⑩ Post, 115 mm long
- ⑪ Tape measure
- ⑫ Case

Figure 6
Scope of delivery
FAG Top-Laser EQUILIGN



Replacement parts

Description	Scope of delivery Quantity	Designation
Manual control device	1	LASER-EQUILIGN-DEVICE
Transmitter/receiver with cable	1	LASER-EQUILIGN.TRANS
Reflector	1	LASER-EQUILIGN.REFLECT
Cable for USB memory stick, 2 m long	1	LASER-EQUILIGN.USB-CABLE
Cable for PC, 2 m long	1	LASER-EQUILIGN.PC-CABLE
Bracket	2	LASER.BRACKET
Chain, 300 mm long	2	LASER.CHAIN300-SET
Post, 115 mm long	4	LASER.POST115-SET
Tape measure, 1 m long	1	LASER.TAPE
Case	1	LASER-EQUILIGN.CASE

Comprehensive range of accessories

A comprehensive range of accessories is available in order to expand the possible applications of the base device
FAG Top-Laser EQUILIGN, see table and *Figure 7*, page 106.

The accessories can be ordered as a set in a handy, robust case or as individual parts.

Accessories, individual parts

Description	Scope of delivery Quantity	Designation
Chain, 600 mm long	2	LASER.CHAIN600-SET
Chain, 1500 mm long	2	LASER.CHAIN1500-SET
Post, 150 mm long	4	LASER.POST150-SET
Post, 200 mm long	4	LASER.POST200-SET
Post, 250 mm long	4	LASER.POST250-SET
Post, 300 mm long	4	LASER.POST300-SET
Magnetic holder including 2 posts, 150 mm long	1	LASER.BRACKET-MAGNET



Alignment

Accessories, set

Description	Scope of delivery Quantity	Designation
Chain, 600 mm long	2	LASER.ACCESS-SET
Chain, 1500 mm long	2	
Post, 150 mm long	4	
Post, 200 mm long	4	
Post, 250 mm long	4	
Post, 300 mm long	4	
Magnetic holder including 2 posts, 150 mm long	2	
Case	1	

- ① Chains, 600 mm
- ② Chains, 1500 mm
- ③ Posts, 150 mm
- ④ Posts, 200 mm
- ⑤ Posts, 250 mm
- ⑥ Posts, 300 mm
- ⑦ Magnetic holder
- ⑧ Case

Figure 7
Accessories, set



000151000

Alignment

Before alignment is carried out, any soft foot must be eliminated. FAG Top-Laser EQUILIGN clearly indicates the soft foot. Each individual foot screw connection is loosened and the device is monitored to see if it displays any changes between the foot screwed firmly into place and the loosened foot. The soft foot can then be eliminated using shims. This eliminates any tendency towards vibration and bearing damage as a result of housing deformation. During measurement, at least three positions are approached at different angles. These must be measured at an angle of at least 90°. The intelligent control system prevents incorrect usage here. The actual condition of the subassembly is then displayed, *Figure 8*.

- ① Display of actual condition
- ② Foot screw connection
- ③ Direction of vertical displacement
- ④ Direction of horizontal displacement



Figure 8
Alignment

When the foot screw connections have been loosened, the vertical misalignment is first eliminated by means of shims. FAG Top-Laser EQUILIGN shows the displacement in real time. This means that the user can monitor on the display how the measurement results change as soon as the subassembly is moved. Horizontal adjustment is then carried out until the symbol with the thumb pointing upwards is displayed. Once the foot screw connections are tightened, the shafts are aligned.

Alignment

Shims FAG Top-Laser SHIM

Shims FAG Top-Laser SHIM are used to eliminate vertical misalignment or soft feet.

These shims are made from corrosion-resistant alloy steel and are available in seven thicknesses (0,05 mm, 0,1 mm, 0,2 mm, 0,5 mm, 0,7 mm, 1 mm, 2 mm) and in four sizes (dimension $c = 15$ mm, 23 mm, 32 mm, 44 mm), see *Figure 9* and table, page 109.

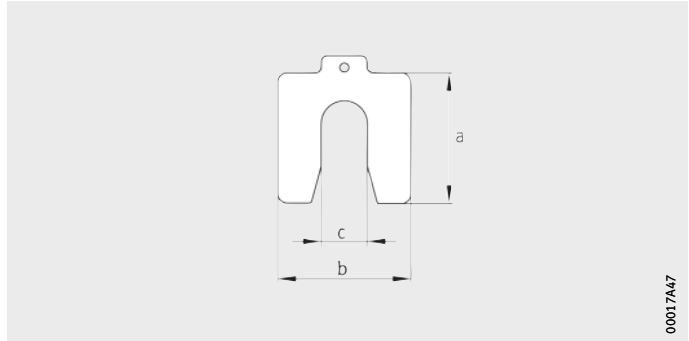

Figure 9
Shim, dimensions

Scope of delivery	Case
Basic set	360 shims: 20 shims each in 3 sizes (dimension $c = 15$ mm, 23 mm, 32 mm) and 6 thicknesses (0,05 mm to 1 mm) 1 extraction hook
Ordering designation	LASER.SHIM-SET
Replacement parts	As replacement parts, we can supply 10 shims each in one of the 4 sizes and one of the 7 thicknesses stated above. Ordering example 1: 10 shims with dimension $c = 15$ mm and 0,2 mm thickness
Ordering designation	LASER.SHIM15×0,20 Ordering example 2: 10 shims with dimension $c = 44$ mm and 0,1 mm thickness
Ordering designation	LASER.SHIM44×0,10

Available shims

Designation	Mass m g	Dimensions in mm			
		a	b	c	Thick- ness
LASER.SHIM15×0,05	11	55	50	15	0,05
LASER.SHIM15×0,10	22	55	50	15	0,1
LASER.SHIM15×0,20	44	55	50	15	0,2
LASER.SHIM15×0,50	110	55	50	15	0,5
LASER.SHIM15×0,70	155	55	50	15	0,7
LASER.SHIM15×1,00	220	55	50	15	1
LASER.SHIM15×2,00	440	55	50	15	2
LASER.SHIM23×0,05	21	75	70	23	0,05
LASER.SHIM23×0,10	42	75	70	23	0,1
LASER.SHIM23×0,20	84	75	70	23	0,2
LASER.SHIM23×0,50	210	75	70	23	0,5
LASER.SHIM23×0,70	295	75	70	23	0,7
LASER.SHIM23×1,00	420	75	70	23	1
LASER.SHIM23×2,00	840	75	70	23	2
LASER.SHIM32×0,05	29	90	80	32	0,05
LASER.SHIM32×0,10	58	90	80	32	0,1
LASER.SHIM32×0,20	115	90	80	32	0,2
LASER.SHIM32×0,50	290	90	80	32	0,5
LASER.SHIM32×0,70	410	90	80	32	0,7
LASER.SHIM32×1,00	580	90	80	32	1
LASER.SHIM32×2,00	1 160	90	80	32	2
LASER.SHIM44×0,05	53	125	105	44	0,05
LASER.SHIM44×0,10	106	125	105	44	0,1
LASER.SHIM44×0,20	212	125	105	44	0,2
LASER.SHIM44×0,50	530	125	105	44	0,5
LASER.SHIM44×0,70	742	125	105	44	0,7
LASER.SHIM44×1,00	1 050	125	105	44	1
LASER.SHIM44×2,00	2 100	125	105	44	2



Further information

- For further information on FAG alignment devices, see TPI 182, FAG Alignment Devices – Top-Laser: SMARTY2 · TRUMMY2 · EQUILIGN · SHIM.
- Enquiries: industrial-services@schaeffler.com, +49 2407 9149-66.

Product overview Checking the operating condition

Temperature measuring device
TempCheck PLUS
TempCheck PRO

TEMP-CHECK-PLUS



TEMP-CHECK-PRO



Digital hand tachometer
TACHOMETER
Sonar device
SOUND-CHECK

TACHOMETER



SOUND-CHECK



Checking the operating condition

Features These devices can be used to manually check the following parameters of rolling bearing arrangements: temperature, speed and noise.

Infrared thermometer FAG TempCheck PLUS

The infrared thermometer FAG TempCheck PLUS is suitable for the thermal monitoring of machine components. This prevents unplanned downtime of machinery.

The infrared thermometer measures the infrared radiation emitted by an object and uses this to calculate the surface temperature. The non-contact measurement makes it possible to easily determine the temperature of difficult to access or moving objects.

The features of FAG TempCheck PLUS are as follows:

- up-to-date infrared temperature technology with high precision glass optics for precise non-contact temperature measurement
- small measurement spot of 13 mm at a distance of up to 140 mm
- measurement spot size corresponds to 20:1 (distance: measurement spot size) at a distance of more than 140 mm
- rapid, precise temperature measurement over a temperature range of -32 °C to $+530\text{ °C}$
- degree of emission adjustable to material
- low mass (150 g)
- USB interface
- report software
- simple to use
- low purchase costs.

Caution 

Do not look into the laser beam or point the laser beam into another person's eyes.



Scope of delivery
Base device

- 1 measuring device
- 1 battery
- 1 wrist strap
- 1 adapter for camera tripod
- 1 carry case
- 1 protective rubber slip cover
- 1 user manual
- 1 report software
- 1 case

Ordering designation

TEMP-CHECK-PLUS

Further information

- For detailed information, see publication WL 80 377, FAG Temperature Measuring Devices.
- Enquiries: industrial-services@schaeffler.com, +49 2407 9149-66.

Checking the operating condition

Infrared thermometer FAG TempCheck PRO

The infrared thermometer FAG TempCheck PRO is suitable for the thermal monitoring of machine components and fluids. Temperatures can be measured by either non-contact or contact means.

The infrared thermometer measures the infrared radiation emitted by an object and uses this to calculate the surface temperature. The non-contact measurement makes it possible to easily determine the temperature of difficult to access or moving objects.

Compared with the FAG TempCheck PLUS, the FAG TempCheck PRO has a wider measurement range, higher optical resolution, a data memory and two additional temperature sensors for contact temperature measurement. The surface temperature sensor can be used to measure the temperature of surfaces by contact means. The immersion sensor can be used to measure the temperature of, for example, fluids or lubricants.

The features of FAG TempCheck PRO are as follows:

- up-to-date infrared temperature technology with high precision glass optics for precise non-contact temperature measurement
- small measurement spot of 13 mm at a distance of up to 260 mm
- measurement spot size corresponds to 40:1 (distance: measurement spot size) at distance of more than 260 mm
- rapid, precise temperature measurement over a temperature range of -32 °C to $+760\text{ °C}$
- degree of emission adjustable to material
- additional temperature sensors for contact measurements
- low mass (150 g), simple handling
- USB interface, memory, report software
- low purchase costs.

Caution



Do not look into the laser beam or point the laser beam into another person's eyes.

Scope of delivery	1 measuring device
Base device	1 battery
	1 wrist strap
	1 adapter for camera tripod
	1 carry case
	1 protective rubber slip cover
	1 immersion sensor for temperature measurement of fluids
	1 surface temperature sensor
	1 user manual
	1 report software
	1 case
Ordering designation	TEMP-CHECK-PRO
Further information	<ul style="list-style-type: none"> ■ For detailed information, see publication WL 80 377, FAG Temperature Measuring Devices. ■ Enquiries: industrial-services@schaeffler.com, +49 2407 9149-66.



Checking the operating condition

Digital hand tachometer FAG TACHOMETER

The speed counter is suitable for two types of operation:

- direct speed measurement using an adapter, track wheel and measurement stylus
- non-contact optical speed measurement using a reflective mark.

Direct speed measurement

For direct speed measurement, the supplied adapter must be fitted. The rubber stylus of the adapter tracks the end face and this is used to determine the speed. The track wheel, which is in contact with the circumference of the shaft or the surface of the belt, measures the surface velocity.

Non-contact speed measurement

For non-contact measurement, a reflective mark is applied to the machine part to be measured. This mark is detected by photoelectric means using visible red light. The device displays the speed in revolutions per minute.

Scope of delivery Base device

- 1 digital hand tachometer
- 1 adapter for direct measurement 1:1
- 1 measurement wheel 6 inch
- 1 measurement wheel 100 mm
- 1 rubber stylus
- 10 reflective marks
- 1 user manual
- 1 case

Ordering designation

TACHOMETER

Replacement parts

- 10 reflective marks

Ordering designation

TACHOMETER.MARKS-REFLEX

Sonar device
FAG SOUND-CHECK

The sonar detector can be used to check rolling bearing noise very easily, quickly and reliably.

Changes in noise due to wear, pitting formation or distortion of the bearing can be detected at an early stage if regular inspection is carried out. In this way, unforeseen operational stoppages and more significant machine damage can be prevented.

The device is used in the same way as a doctor's stethoscope. The tips of the earpiece are placed in the ear canals to provide insulation against background noise. The insulated grip is held between the thumb and index finger like a pencil. The sensor is placed firmly on the part to be measured. If a noise is heard, the sensor is moved until its volume reaches a maximum.

Scope of delivery 1 sonar device

Base device 1 case

Ordering designation **SOUND-CHECK**



Product overview Vibration diagnosis

Vibration measuring device Detector III

DETECT3-KIT, DETECT3-KIT-RFID, DETECT3.BALANCE-KIT



000190B1

Online monitoring system SmartCheck

SMART-CHECK



00017A65

Online monitoring system DTECT X1_s WiPro_s

DTECTX1-S, DTECTX1-S-WIPRO



000193BA

Online monitoring system ProCheck

PRO-CHECK

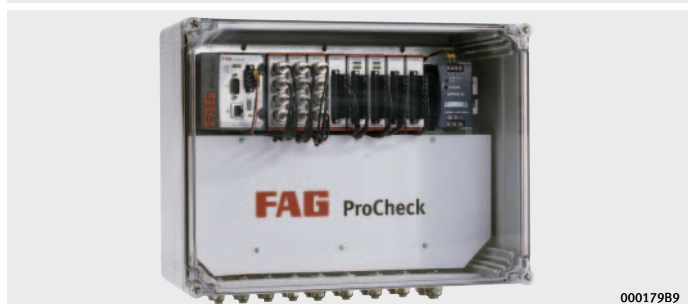

000179B9

Vibration diagnosis

Features Vibration diagnosis is the most reliable method for identifying the start of machine damage at an early stage. It can be used to precisely detect not only imbalance and misalignment but also rolling bearing damage and gear tooth defects.

FAG vibration measuring devices help in planning maintenance work, increasing bearing life and reducing costs. As a result, plant availability is increased and the risk of unplanned downtime is reduced.

Monitoring devices – offline and online In the field of offline monitoring devices (regular monitoring), Schaeffler offers the FAG Detector III.

The online monitoring systems (continuous measurement) include FAG SmartCheck, FAG DTECT X1_s, FAG WiPro_s and FAG ProCheck.

In order to achieve optimum networking to plant control facilities or monitoring centres, all online systems have versatile communication options as standard.

Worldwide service On all devices relating to condition monitoring, Schaeffler offers a worldwide service – from the customer hotline to customer-specific service contracts.

Vibration measuring device FAG Detector III FAG Detector III is a handy, easy to use vibration measuring device. Due to preinstalled standard configurations in accordance with DIN ISO 10816, this is a plug-and-play solution allowing early and authoritative information on the condition of machinery, entirely without time-consuming training or system configuration work.

This allows, for example, rapid inspection of ventilators, pumps, electric motors, compressors or vacuum pumps. All the user must do is start the measurement process by pressing a few buttons and wait until it is completed. The device evaluates the measurement results and presents the results, with self-explanatory symbols, on the device display, *Figure 1*.



- ① Value OK
- ② Prealarm
- ③ Main alarm



Figure 1
Symbols in the device display

Vibration diagnosis

The system also has the following features:

- non-contact temperature measurement
- speed detection
- route function
- report generator.

Analysis software

For more detailed analysis, the PC software Trendline is available free of charge and includes comprehensive functions.

These include the Viewer, which gives the user a wide range of tools for data evaluation. The integrated rolling bearing database, containing approximately 20 000 bearings from various manufacturers, facilitates easier and more efficient analysis of the measured data. Since the damage frequencies can be incorporated in the measurement results, simple damage analysis is possible.

Automatic detection of measurement points

The automatic detection of measurement points through the use of RFID technology gives error-free and precise identification of the measurement points on a measurement route. FAG Detector III identifies the measurement points by means of RFID tags on the machinery. With the proven FAG Detector III, mobile vibration and temperature monitoring is thus quicker, simpler and more reliable. The functionality of automatic measurement point detection is not available worldwide.

Further information

- Enquiries: industrial-services@schaeffler.com, +49 2407 9149-66.

Balancing function

A further special feature of FAG Detector III is the balancing function. For this purpose, the optionally available Balancing Kit is required. This makes it possible to not only detect but also eliminate imbalances.

The results of the balancing process are also transferred to the Trendline software for evaluation.

Ordering examples The vibration measuring device FAG Detector III is available in two variants, with the balancing function available for ordering in an upgraded version.

Scope of delivery
Base device

- 1 base device with rechargeable battery
- 1 accelerometer, attached by magnetism, and sensor cable
- 1 infrared temperature sensor
- 1 charger with worldwide compatibility
- 1 PC data cable (serial and USB)
- 1 user manual
- 1 protective bag with holder for temperature sensor
- 1 free of charge PC software Trendline
- 1 case

Ordering designation **DETECT3-KIT**

Scope of delivery
Device with automatic measurement point detection

- As DETECT3-KIT
- 1 RFID reader (integrated)
- 5 RFID tags for identifying the measurement point

Ordering designation **DETECT3-KIT-RFID**

Scope of delivery
Upgrade level with balancing function

- 1 accelerometer, attached by magnetism, and sensor cable
- 1 trigger sensor, optical
- 1 trigger sensor, induction
- 1 reflex mark for trigger sensor
- 1 cable for trigger sensor, 10 m
- 1 magnetic holder for trigger sensor
- 1 extension for magnetic holder
- 1 balance
- 1 dongle for activation of balancing function
- 1 case

Ordering designation **DETECT3.BALANCE-KIT**

Accessories Sensor extension cables 5 m or 15 m long are available by agreement.
The charging dock, mounting pads and additional RFID tags are available by agreement.

Further information

- For detailed information, see TPI WL 80-64, FAG Detector III – The Solution for Monitoring and Balancing or www.FAG-DetectorIII.de
- Enquiries: industrial-services@schaeffler.com, +49 2407 9149-66.



Vibration diagnosis

Online monitoring system FAG SmartCheck

FAG SmartCheck is a compact, innovative, modular online measuring system for continuous monitoring of machinery and process parameters on a decentralised basis. It can be used on assemblies where such monitoring was previously too cost-intensive.

FAG SmartCheck is suitable, for example, for early detection of rolling bearing damage, imbalances and misalignments on:

- electric and geared motors
- vacuum and fluid pumps
- ventilators and fans
- gearboxes and compressors
- spindles and machine tools
- separators and decanters.

Plug-and-play system

FAG SmartCheck is ready for immediate use. When supplied, it already has a set of key data that facilitate general, reliable machinery monitoring.

In addition, predefined configuration templates are available for monitoring of items such as fans, pumps and bearings.

These can easily be matched to individual requirements. Due to the integrated bearing database of FAG and INA standard bearings, data configuration and later analysis are simpler. The system has an independent learning mode that identifies the alarm thresholds.

Parameters monitored

In addition to the standard parameters of vibration and temperature, it is possible to record other classic operating parameters such as pressure or flow rate. All parameters can be correlated with each other and included in the alarm configuration.

The data are recorded and analysed centrally by the system. The current machine condition can be displayed directly on the device or transferred to any control facility as required. It is only necessary to integrate FAG SmartCheck in the existing network structure.

Control using Mitsubishi controllers

General communication with controllers can be carried out through connection of the analogue and digital interfaces with the controller. The communication protocol SLMP has been implemented specially for Mitsubishi controllers of the L and Q series. This allows direct transfer of the measurables status and gives information, for example, on rolling bearing damage, imbalance, misalignments or temperature fluctuations that can be notified in plain text to the operator by means of the controller.

Access via the Internet FAG SmartCheck has an intuitive user concept designed as a Web interface. It is therefore possible to access the system via the Internet using any standard Internet browser. The Web interface can be used to configure the system and view current data.

Remote monitoring The data can be transferred to other locations by remote access and analysed there by the operator or external service providers such as the Schaeffler vibration experts. This is particularly important for customers who still have little experience of data analysis or wish to outsource this function.

Further information

- For detailed information, see TPI 214, FAG SmartCheck or www.FAG-SmartCheck.com
- Enquiries: industrial-services@schaeffler.com, +49 2407 9149-66.

Online monitoring system FAG DTECT X1_s

FAG DTECT X1_s is a flexible online system for the monitoring of rotating components and elements in the machinery and plant industry. Typical applications can be found, for example, in the steel, raw materials, paper and marine industries.

The system gives early, reliable detection of possible damage and thus helps to prevent unplanned and expensive downtime. This reduces the risk of possible production shutdowns. As a result, the capacity utilisation of machinery and plant is increased.

Versatile system The system can be tailored to customer-specific requirements by means of the software.

The base device is available as a 2 and an 8 channel system. The system is suitable for connection of all conventional acceleration, speed and proximity probes.

Due to its compact size and robust housing (class IP 67), it is suitable for a wide range of monitoring applications. It has standardised connectors allowing easy installation on machinery and plant.

Remote monitoring Defects and damage can be detected on machinery without the need for a diagnosis expert on site. The data can be transferred to other locations by remote access and analysed there, for example by the Schaeffler vibration experts.

Further information

- For detailed information, see TPI 170, FAG DTECT X1_s.
- Enquiries: industrial-services@schaeffler.com, +49 2407 9149-66.



Vibration diagnosis

Online monitoring system FAG WiPro_s

FAG WiPro_s allows online monitoring of wind farms – onshore and offshore. The system gives early and reliable detection of possible machine damage. This helps to prevent unplanned downtime and expensive secondary damage. Due to its small size, it can easily be accommodated in small spaces such as the nacelle of a wind turbine.

Versatile system

FAG WiPro_s is equipped with a signal processor and evaluates all measurement signals internally. Due to the intelligent linking of expert knowledge with information from the turbine, it is possible to keep the transferred data volume very small. This is particularly important where a large number of turbines must be continuously monitored over a long period.

Any wind farm can be networked using the system, whether the turbines are connected using copper cables, fibre optics, ISDN or analogue lines or even if no telephone connection at all is present.

Certification

The system is certified by Germanischer Lloyd.

Remote monitoring

The automatic messaging function by means of TCP/IP, wifi modem (optional), landline modem or DSL router allows efficient worldwide monitoring. The data can be transferred to other locations by remote access and analysed there, for example by the Schaeffler vibration experts.

Further information

- For detailed information, see WL 80 373, Flyer FAG WiPro_s.
- Enquiries: industrial-services@schaeffler.com, +49 2407 9149-66.

Online monitoring system FAG ProCheck

FAG ProCheck is an online monitoring system. It can be used to prevent unplanned downtime and for quality control. The system offers a high level of functionality and is available in a range of variants – from an 8 channel to a 16 channel system.

Parameters monitored

FAG ProCheck continuously records data on vibration, temperature and other process parameters and subsequently carries out their evaluation. As a result, incipient damage and its causes can be detected at a very early stage and the appropriate countermeasures can be introduced in good time. This gives a considerable reduction in operating costs.

In addition, FAG ProCheck offers the possibility of correlating a large number of analogue and digital input and output signals to the vibration data. These channels also allow simple communication with higher level systems such as process control systems.

Versatile system

Due to its extremely robust and compact design, this system is ideally suited for use in almost all industrial segments. The system can be used in steelworks, paper machinery, cement plants or in the oil and gas industry.

Remote monitoring

Defects and damage can be detected on machinery without the need for a diagnosis expert on site. The data can be transferred to other locations by remote access and analysed there, for example by the Schaeffler vibration experts.

Explosion-protected variant

An explosion-protected version of FAG ProCheck is available by agreement. In this version, a specially pressure-encapsulated housing prevents the system coming into contact with an explosive atmosphere. This is because wherever flammable gases, vapours, fluids or dust occur, the presence of oxygen and an ignition source can rapidly cause an explosion.

Further information

- For detailed information, see TPI WL 80-69, FAG ProCheck – State of the Art Machine Monitoring for Maximum Availability.
- Enquiries: industrial-services@schaeffler.com, +49 2407 9149-66.

Customer-specific solutions

The plant visualization, which is individually tailored to the customer's requirements, gives a user interface that allows a rapid overview of the condition of the plant. Depending on the complexity of the plant, this display can be arranged on several levels.

Other online monitoring systems

Other monitoring systems for the requirements of specific sectors are available by agreement.



Product overview Monitoring of components

Online monitoring system ProTorq

ProTorq



Monitoring of components

Features	Online monitoring systems of this type are used for estimating the remaining life of heavily loaded components as well as for process monitoring.
Online monitoring system FAG ProTorq	<p>The online monitoring system FAG ProTorq is suitable for monitoring applications in many sectors due to its versatility.</p> <p>It facilitates:</p> <ul style="list-style-type: none">■ early detection of overload and possible failure of components■ reliable estimates of remaining life■ optimised component utilisation and maintenance planning■ increased quality and production performance■ design verification and optimisation of power train elements.
Function	<p>FAG ProTorq can be used to detect signals such as torque, elongation, force, pressure, temperature and displacement changes in parallel on up to 32 channels. These can be correlated with product-specific data for evaluation of the signals. In addition, the system allows calculation and comparison of signals with each other as well as automatic analysis. As a result, the user receives a reliable statement on the condition of the component or process.</p> <p>The measurement sensor system is also suitable for harsh ambient conditions such as those in rolling mill or offshore applications.</p>
Customer-specific solutions	<p>The versatile application possibilities covered by FAG ProTorq require precise definition of the key values to be monitored when configuring the hardware and software. In this way, the system can be individually matched to the monitoring task. Schaeffler accompanies the customer throughout the project phase. Following system configuration by Schaeffler, the user receives intensive training that equips him to use the system independently. Upon customer request, the Schaeffler can undertake evaluation of the measurement data.</p>
Troubleshooting	<p>If a permanent installation is not required, there is also the option of temporary measurement carried out by Schaeffler. The objective here is to find short term approaches to solutions where unexpected component failure occurs.</p>
Further information	<ul style="list-style-type: none">■ For detailed information, see TPI 199, FAG ProTorq.■ Enquiries: industrial-services@schaeffler.com, +49 2407 9149-66.



Product overview Monitoring of lubricants

Grease sensor GreaseCheck

GREASE-CHECK



Oil sensor Wear Debris Check

WEAR-DEBRIS-CHECK



Monitoring of lubricants

Features The operating life of the lubricant is the decisive value for the bearing life. Depending on the application, either a grease or oil sensor can be used for monitoring. The lubricant can be topped up or replaced in good time before damage occurs.

Grease sensor FAG GreaseCheck

The grease sensor has a diameter of 5 mm and is inserted in a hole in the housing as close as possible to the rolling bearing. The sensor is positioned in the lubricant. This grease sensor optically measures the water content, turbidity, thermal and mechanical wear and the grease temperature directly in the bearing arrangement. This information is transferred by cable to the evaluation unit, *Figure 1*. The evaluation unit generates an analogue signal that gives the user information rapidly and easily on the condition of the grease.

- ① Grease sensor
- ② Electronic evaluation system

Figure 1
Grease sensor and
electronic evaluation system



In the past, bearings were regreased as a function of time. The grease quantities and lubrication intervals were calculated numerically. If the grease sensor is used, regreasing can be carried out as a function of condition.



- Advantages** The grease sensor facilitates:
- lubrication appropriate to needs
 - lower lubricant costs
 - prevention of unplanned downtime
 - lower maintenance costs
 - lower equipment costs.

- Further information**
- For detailed information, see TPI 234, FAG GreaseCheck.
 - Enquiries: industrial-services@schaeffler.com
+49 2407 9149-66.

Monitoring of lubricants

Oil sensor FAG Wear Debris Check

Oil sensors of this type can be used to determine wear at an early stage in heavily loaded industrial gearboxes on the basis of particles in the oil. The debris particles that can indicate a failure can be detected in the oil several months in advance. Such particles can be identified at an early stage through monitoring of the lubricant. This helps to prevent failures and downtime. The oil sensor is installed in an ancillary flow of the recirculating lubrication system in the gearbox ahead of the filter or in a separate circuit.

Typical applications for the FAG Wear Debris can be found, for example, in gearboxes in raw material extraction plant, planetary gearboxes in wind turbines or in ship propulsion systems.

The features of the oil sensor are as follows:

- monitoring of the number of particles in the oil
- differentiation of the particles into ferrous and non-ferrous metals
- classification of the particles according to size
- possible integration in an online monitoring system for linking of oil particle and vibration data.

Where oil and vibration monitoring facilities are combined, damage in gearboxes with recirculating oil lubrication can be detected at an early stage and the source can be determined. In this way, it is possible to prevent production shutdowns or secondary damage.

Further information

- For detailed information, see WL 80 366, Flyer FAG Wear Debris Check.
- Enquiries: industrial-services@schaeffler.com, +49 2407 9149-66.





FAG



Services

Services

	Page
Features	
Mounting and dismounting.....	132
Lubrication.....	135
Condition Monitoring.....	136
Corrective maintenance.....	142
Rolling bearing reconditioning.....	143
Technical consultancy.....	146
TCO approach.....	148



Services

Features

Schaeffler offers, irrespective of the manufacturer of the bearing arrangement, a wide range of services relevant to the lifecycle of a rolling bearing: starting with mounting and progressing through maintenance to the reconditioning of rolling bearings.

During the operational phase, the Schaeffler experts provide support through services in the fields of condition monitoring and corrective maintenance. Companies that wish to build up their knowledge in the areas of rolling bearings and condition monitoring also have access to the Schaeffler training and consultancy portfolio on site, centrally or online. Our e-learning portfolio on the Internet provides the first steps into this field. In this way, customers benefit from the expertise of a leading supplier of rolling and plain bearings.

Mounting and dismounting

The Schaeffler industrial service experts offer mounting and dismounting services for rolling bearings that are applicable across industrial sectors. They have detailed knowledge and extensive experience in all industrial sectors.

The experts in the Industrial Service function are trained and skilled personnel who can provide reliable, rapid and competent assistance. The services are provided worldwide, either on site at your location or in Schaeffler workshop facilities.

Mounting and dismounting services

The mounting and dismounting services, *Figure 1*, page 133, include:

- mounting and dismounting of rolling bearings, plain bearings and bearing systems of all types by experts available worldwide
- measurement and condition analysis of bearing arrangements
- problem solving and preparation of concept solutions
- design and manufacture of special tools
- leasing of tools (only available in Europe)
- emergency service
- training courses on products and mounting
- certification of mounting and dismounting processes.

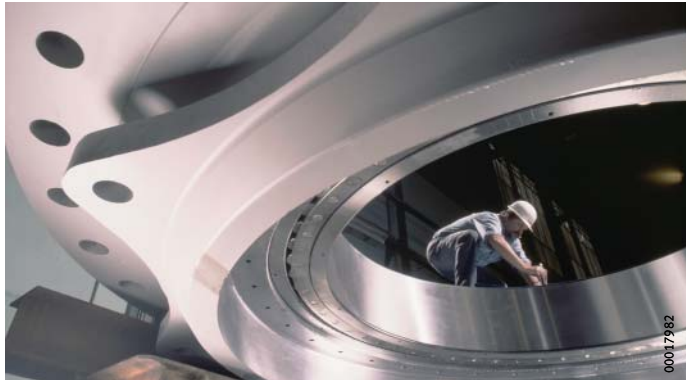

Figure 1
Mounting services

Advantages

The mounting services give the following advantages:

- readily available service worldwide
- rapid mounting or dismounting through precise preparation
- professional mounting and dismounting using special high-quality tools
- increased plant availability and productivity as a result of reduced unplanned downtime
- correct use of bearings of all types as a result of customer training.

Rental of tools

European customers, who require special mounting and dismounting tools or measuring equipment only infrequently can rent these from Schaeffler on a weekly basis.

Our service includes:

- rapid delivery to the installation site
- rental costs include shipment costs
- checked quality products in keeping with the latest technological developments
- delivery of the tools, including all add-on parts
- user manuals available in several languages.

If one of our qualified experts in the Industrial Service function is commissioned to carry out the particular activity, rental costs are not generally incurred.



Services

Certification Mounting errors are the cause of approximately 25% of all premature bearing failures. In addition to basic knowledge of rolling bearings, it is particularly important to have theoretical and practical knowledge of the correct mounting and dismounting procedures in order to achieve a long bearing operating life, *Figure 2*.



Figure 2
Training on dismounting
Inner ring of wheelset bearing

In order to ensure that the training received by mounting personnel is as close to reality as possible, Schaeffler offers certification of individual mounting and dismounting processes.

Here, information on handling rolling bearings correctly and avoiding errors during mounting and dismounting is imparted by Schaeffler experts. This is carried out with direct reference to the specific application and the individual circumstances of the customer. A practical demonstration of the mounting and dismounting process is then provided, which also covers adherence to the necessary processes and specifications.

Finally, the training participants must put their acquired knowledge to the test. Only then do they receive application-specific certification from Schaeffler.

Further information ■ tel. +49 9721 91-4995, fax +49 9721 91-3639.

Lubrication In more than half of all cases, inadequate lubrication is the cause of unplanned machine downtime. The life of rotating machine elements can be significantly extended by the use of greases appropriate to the different operating and environmental conditions as well as the definition of and adherence to lubrication intervals and quantities.

- Services Services relating to lubrication, *Figure 3*, include:
- the selection of lubricants and lubrication systems
 - the preparation of lubrication and maintenance plans
 - lubrication point management
 - consultancy on lubricants
 - lubricant investigations and tests.

- Advantages The Schaeffler lubrication service helps to:
- prevent failures of rotating components
 - increase productivity
 - reduce lubrication costs.

An extensive selection of high quality rolling bearing greases is available. These greases were specially tested and selected for use in rolling bearings.



Figure 3
Support from the lubrication service: large grease selection

Services

- Condition Monitoring** The malfunction-free and optimised operation of complex machinery and plant can normally only be achieved by means of condition-based maintenance. Schaeffler uses various methods for this task.
- Vibration measurements** The measurement of vibrations is a proven method here. Vibrations reveal damage in machinery at a very early stage. The vibration expert can assess the condition of the machine without the need for any dismantling work. A large proportion of possible causes of damage can thus be detected and assessed with little work. As a result, damaged components can be replaced as part of planned downtime. Depending on the type of machine and its importance for the production process, condition monitoring can be carried out by means of either continuous (online) monitoring or regular (offline) monitoring.
- Continuous monitoring** For production-critical machinery, continuous monitoring, *Figure 4*, page 137, by means of vibration diagnosis is indispensable in many cases. Investment in such monitoring systems often pays for itself after a few months due to the reduced failure costs. Depending on the area of application, Schaeffler offers a wide range of solutions, including single channel standalone solutions for smaller equipment and medium-sized systems with up to 8 channels that can be extended on a modular basis. In addition to giving advice on selecting the right system, Schaeffler also implements monitoring of the machine. This includes not only hardware selection but also system configuration and, where necessary, its integration into existing systems. The customer can decide whether to carry out plant monitoring himself or to enlist the services of Schaeffler for online monitoring. Due to the communication options of the monitoring systems, remote analysis can be carried out by the Schaeffler experts.

Figure 4
Continuous monitoring



Regular monitoring

The failure of so-called “B” or “C” category plant items does not lead directly to downtime and therefore does not necessarily lead to expensive secondary damage. For such machine parts, offline monitoring is generally recommended as a more economical option. The Schaeffler experts can assist in identifying the most economically appropriate solution between cost-effective continuous monitoring and regular monitoring.

In this type of monitoring, machinery is examined and assessed by vibration analysis at regular intervals, for example every four weeks. This regularity gives more in-depth knowledge of the normal condition of the machine. Deviations can thus be detected. For the monitoring concept, the selection of measurement points and monitoring accessories as well as the measurement interval play a decisive role. If deviations occur during measurement or if trends are to be investigated, the data can be sent to the Schaeffler Diagnosis Centre. Vibration experts will then analyse the data and prepare a diagnosis report. Through working with the Schaeffler experts, customers can build up their own know-how in analysis.

If no personnel are available for data logging, Schaeffler can also offer support in data logging. The company’s experts can carry out regular measurements on site.



Services

Troubleshooting Where malfunctions occur on a machine, defects must be detected and rectified very quickly. Based on many years of experience with different sectors and applications, the Schaeffler diagnosis experts are well versed in such troubleshooting tasks. Various types of information are fed into the analysis. These include earlier measurement records or repair reports. If no measurement records are available, the diagnosis experts orient themselves to the specific task through observation, perusing the machine documentation and discussions with the machine operators.

Problems or malfunctions in machine operation often become apparent through changes in vibration behaviour, unusual temperature patterns or similar phenomena. Where the diagnosis experts carry out measurements on the machine themselves, the measurement method is selected as a function of the specific machine and the type of malfunction. The Schaeffler diagnosis experts are familiar with all analytical techniques, from vibration measurement to torque analysis or endoscopy. As a result, they can quickly identify malfunctions and prepare proposed solutions. The investigation is closed out by a handover discussion between the diagnosis experts and all relevant employees on site. In addition to the results of the investigation, the recommended countermeasures are discussed in particular.

Modal analysis Modal analysis is a particular form of vibration diagnosis. This method does not examine individual components of a machine but the machine as a whole. The aim is to determine the overall vibration behaviour of the machine. A model of the machine is created on the computer and a large number of measurement points are defined. The machine is then specifically excited to vibration using an impulse hammer. Based on parallel measurement of the excitation and resulting machine vibrations at the various measurement points, a vibration model of the machine can be determined by the computer and presented in three dimensions.

Modal analysis has a wide variety of possible applications:

- determination of natural frequencies or resonance frequencies:
 - Due to design-related factors such as mass and rigidity, each machine has one or more natural frequencies. If the speed of the motor in a machine is within the range of a natural frequency, extreme vibrations may occur in the machine. With the aid of modal analysis, the Schaeffler vibration experts can submit recommendations for design improvements to the machine.
- detection of the “soft spot” in a machine:
 - If a high level of vibration occurs during initial operation or after a technical modification of a machine, this may be due to a so-called “soft spot”. This is defined as a rigidity problem, often caused by a poor quality connection between two machine parts, for example at a screw connection. For analysis, the measurements are used to produce an animation showing the movements of the machine. Showing the movement of the individual machine parts in relation to each other quickly leads to the “soft spot” in the machine. A joint discussion can be held to prepare proposals for improving the design of the machine.



Services

Endoscopy Digital, optical endoscopes can be used to examine the interior of a machine, *Figure 5*, to determine the extent of damage. The images can be stored as a digital photograph or video and form the basis of diagnosis by Schaeffler experts. The condition of individual components such as rolling bearings and gear teeth can be assessed. If the bearings inspected are Schaeffler products, the customer also has access to the knowledge of the Schaeffler application engineers. These experts will prepare a detailed damage analysis and submit proposals for improvement.



Figure 5
Endoscopy

Thermography Thermography is one of the most important non-destructive diagnostic techniques, *Figure 6*. Many technical problems manifest themselves in the form of heat generation, which can be detected with the aid of a high resolution infrared camera. The major advantage of thermography is the rapid, non-contact collection of temperature data. If a photograph is taken at the same time, the temperature patterns present in a machine part can be assigned on site.

Thermography can be used for assessment in relation to numerous objects, such as in the case of:

- non-contact monitoring of rolling bearings during operation
- thermal monitoring of processes.

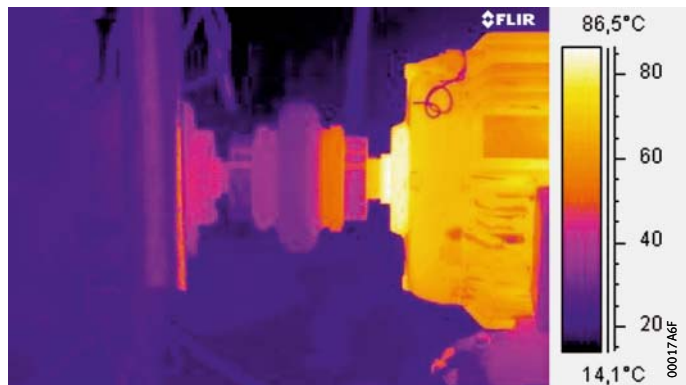

Figure 6
Thermography® FLIR systems
Approval inspection of new plant

The combination of different diagnostic techniques enables the Schaeffler experts to carry out assessment of new plant irrespective of the manufacturer. Frequently occurring installation defects can thus be detected in the commissioning phase. These defects include: misalignment of motors, pumps or fans as well as incorrect electrical connections in switch cabinets. The Schaeffler experts check the most common problems and record the actual status. Where necessary, corrective measures can then be requested from the plant manufacturer or operator in good time. If such defects remain undetected over the period of the warranty, their removal and the secondary damage may incur considerable costs and downtime.

Further information

- Enquiries: industrial-services@schaeffler.com, +49 2407 9149-66.



Services

Corrective maintenance

Once a machine problem has been diagnosed, it should be eliminated as quickly as possible. Two of the most frequent problems, namely imbalance in pumps and fans as well as misalignment of machine components to each other, can be corrected directly by the Schaeffler experts.

Balancing

Imbalance is one of the most frequent defects that lead to unexpected failure of rotating machine elements. Correct balancing gives a decisive increase in the life of rotating machine parts. This increases the productivity and availability of the machine. The Schaeffler experts reduce to a normal level the imbalances that, for example, occur as a result of contamination, wear and repairs. They can detect and eliminate the causes on machinery operating at a speed of 40 min^{-1} to $10\,000 \text{ min}^{-1}$. Typical examples of such machines include pumps, ventilators, compressors, turbines and motors. Schaeffler offers not only a detailed analysis of the causes of the problem but also the elimination of imbalances.

Alignment

Many machines consist of different components, such as electric motors and pumps. After installation, repair or overhaul, the components of such machines must be aligned with each other, *Figure 7*. If this is carried out incorrectly or not at all, this results in high loads being placed on the bearings as well as increased energy demand and wear.

In addition to laser alignment systems, Schaeffler offers the alignment of machinery as a service. Where necessary, the Schaeffler service technicians will take the necessary laser alignment system to the customer and carry out alignment of the machine in accordance with the manufacturer's specifications. The work is then documented.



Figure 7
Alignment

Further information

■ Enquiries: industrial-services@schaeffler.com,
+49 2407 9149-66.

Rolling bearing reconditioning

It is often the case that new rolling bearings are fitted although the existing bearings could be restored to as-new condition by means of appropriate reconditioning. In many cases, reconditioning of rolling bearings is significantly more cost-effective than using new bearings, *Figure 8*.

- ① Before reconditioning
- ② After reconditioning

Figure 8
Rolling bearing raceway and rollers before and after reconditioning



Advantages

Reconditioning is carried out irrespective of manufacturer and is thus not restricted to products of Schaeffler Technologies. Before reconditioning, the condition of the bearings can be assessed on site in consultation with experts from the Global Technology Network.

The advantages for the customer are as follows:

- reductions in life cycle costs (LCC = Life Cycle Costs)
- increases in operating life
- savings in material and energy costs
- reductions in inventory costs
- high flexibility through short lead times
- feedback on the characteristics and frequencies of damage.

Quality

Schaeffler performs reconditioning of rolling bearings to uniform standards throughout the world. All sites apply identical processes and guidelines. Schaeffler rolling bearings are processed in accordance with the original drawings. In the case of all bearings, work is carried out using only original components and original replacement parts. High quality reconditioning is achieved as a result of our comprehensive knowledge of rolling bearings.



Services

- Market sectors** Reconditioning of rolling bearings is of particular interest if these are used in machinery or vehicles in the following market sectors:
- raw material extraction and processing
 - metal extraction and processing
 - pulp and paper
 - railways.
- Dimensions** Reconditioning and, where required, modification can be carried out on rolling bearings with an outside diameter D from 100 mm to 4 500 mm. Please contact us for information on reconditioning or modifying bearings with other outside diameters.
- Overview** The operations necessary in reconditioning are dependent on the condition of the rolling bearing. In order to allow a reliable statement of the work required, the rolling bearing must be disassembled, cleaned and then carefully examined.
- Beyond this requalifying process (Level I), which is always necessary, further reconditioning steps may be appropriate, *Figure 9*.

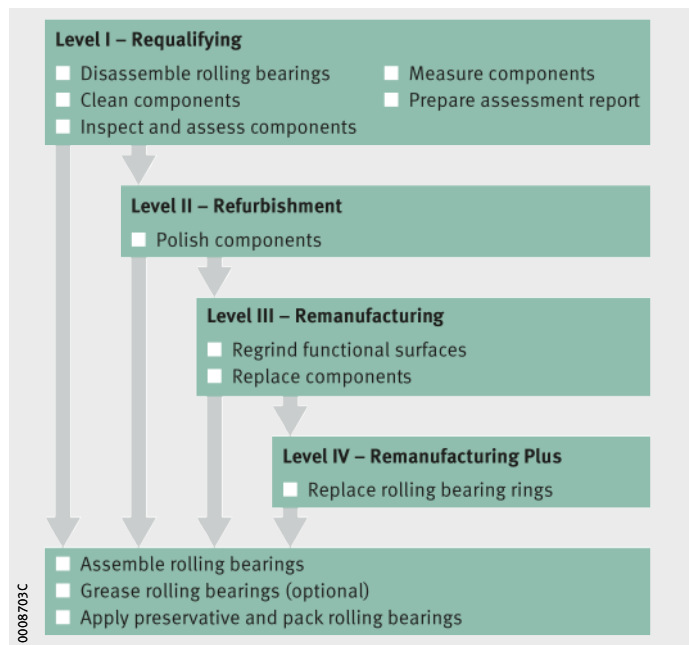

Figure 9
Level I to Level IV

Worldwide reconditioning

Schaeffler offers the reconditioning of rolling bearings at several locations worldwide, *Figure 10*.



Figure 10
Reconditioning locations

Addresses

Europe	China
<p>Schaeffler Technologies AG & Co. KG</p> <ul style="list-style-type: none"> ■ Georg-Schäfer-Straße 30 97421 Schweinfurt¹⁾ Tel. +(49) 9721 91-1919 reconditioning@schaeffler.com ■ Mettmanner Straße 79 42115 Wuppertal²⁾ Tel. +(49) 202 293-2226 reconditioning@schaeffler.com 	<p>Schaeffler (China) Co., Ltd. (Taicang) Schaeffler Trading (Shanghai) Co., Ltd.</p> <ul style="list-style-type: none"> ■ No. 1 Antuo Road, Anting, Jiading District 201804 Shanghai Tel. +(86) 21 3957 6500 reconditioning@schaeffler.com <p>Schaeffler (Ningxia) Co., Ltd.</p> <ul style="list-style-type: none"> ■ Wenchang South Road 86 Xixia District 750021 Yinchuan Tel. +(86) 95 1207 2333 reconditioning@schaeffler.com
USA, Canada	Australia
<p>Schaeffler Group USA Inc.</p> <ul style="list-style-type: none"> ■ 308 Springhill Farm Road Fort Mill, SC 29715 Tel. +(1) 888 462-8227 reconditioning@schaeffler.com 	<p>Bearing Engineering Services (BES) (A Division of Schaeffler Australia PTY Ltd)</p> <ul style="list-style-type: none"> ■ 10 Melissa Street, Auburn, NSW 2144 Tel. +(61) 2 987 17 81 11 BES.au@schaeffler.com www.schaeffler.com.au/bes

¹⁾ Reconditioning for bearings with $D \leq 500$ mm.

²⁾ Reconditioning for bearings with $D > 500$ mm.

Further information

- TPI 207, Reconditioning and Repair of Rolling Bearings.



Services

Technical consultancy

Companies that wish to change to the concept of condition-based maintenance are supported by Schaeffler with training, attendance during the introductory phase, ongoing advice during the period of use and service contracts.

Condition-oriented maintenance

In condition-oriented maintenance, machinery and plant no longer undergo maintenance work on the basis of failures or times but on their assessed condition. In partnership with the customer, the Schaeffler advisory experts prepare plans that give recommendations for action on the basis of the results of condition monitoring. These recommendations result in targeted maintenance measures and thus to reduced costs.

Service concepts for plant manufacturers and operators

Services are not “off the peg” products and the requirements vary according to the machine and the knowledge on site. Due to the wide portfolio of Schaeffler services, local certified Schaeffler employees can weave together the right package of Schaeffler training and services together with in-house activities. The scope is enormous and dependent on the prior knowledge and usable work capability as well as the requirements for quality of monitoring.

The following four examples show the extent of the scope and how widely service concepts can vary. Starting from the customer requirements, the Schaeffler experts prepare a concept to meet the needs and assist in its implementation.

Example 1: Instruction

Company A has employees with experience in the field of condition diagnosis.

In this case, it is sufficient to instruct the employees of the company in the use of the systems and accompany them while making the initial steps. In difficult cases, assistance can be requested from the Schaeffler experts. They will help in the analysis and formulation of measures.

Example 2: Learning Company B would like to build up its own knowledge in the field of condition diagnosis.

Condition diagnosis is a complex subject. Building up knowledge therefore takes time. In such cases, Schaeffler offers a two-year programme, after which even customers without prior knowledge can themselves monitor the condition of their machinery. Once the standardised training has been carried out, the support given by the Schaeffler experts is progressively reduced in stages and the customer's employees use their new knowledge directly in their daily work.

Example 3: Outsourcing Company C would like to completely outsource the area of condition diagnosis.

Schaeffler offers complete packages under which Schaeffler provides the entire service. This begins with the initial operation of systems and progresses through continuous monitoring to complete leasing of the hardware, such that no initial costs are incurred by the customer. Such monitoring packages are very attractive, for example, to operators of wind turbines.

Example 4: Offering a service Company D is a plant manufacturer and would like to offer condition monitoring as a service itself.

In this case, Schaeffler acts as a subcontractor for the mostly portable monitoring systems, as a trainer to the service employees of the plant manufacturer and as an expert team. The expert team always moves into action when machines show sets of characteristics that cannot be clearly assessed by the employees of the plant manufacturer. The plant manufacturer can thus offer its customers a highly qualified monitoring service without having to establish its own experts.

Further information ■ Enquiries: industrial-services@schaeffler.com, +49 2407 9149-66.



Services

TCO approach

The Schaeffler approach to reducing total costs (TCO, Total Cost of Ownership) is a practically based concept for plant operators (MRO) and plant manufacturers (OEM). The aim is to reduce operating costs associated with rolling bearings and increase plant availability on a continuing basis. The costs incurred are objectively and measurably compared with the benefits to be accrued by means of appropriate parameters.

In the case of MRO, Schaeffler works as a partner with employees from production and maintenance facilities to optimise and conserve the value of the plant. With the user, Schaeffler works on specifically named problems and submits technical approaches to solutions. Furthermore, Schaeffler provides proposals for cost reductions that are based on experience within specific sectors and spanning different sectors. This analysis covers plant components, operations and qualification measures as well as their practical implementation.

Schaeffler is also interested in advising OEMs on product design with favourable maintenance-related characteristics, in order to achieve a significant contribution to reductions in operating costs as early as the plant design phase.





FAG



Training

Training

	Page
Product overview	
Training.....	152
Features	
Target groups	153
Structure	153
Training locations	154
Quality assurance.....	154
Training courses, standard and individual	155
Training material	156



Product overview Training

Rolling bearing technology Training example

TRAINING-BEARING-BASIC-TECH-2



Mounting of rolling bearings Training example

TRAINING-BEARING-MOUNTING-PRACT



Machinery monitoring Training example

TRAINING-CM-D3-BASIC



Training

Features Appreciating the use of rolling bearings, linear guidance systems and plain bearings as indispensable elements in thousands of applications requires the necessary understanding of these machine elements. Courses provided by Schaeffler Technologies guide the participant through the complete product portfolio. Starting from product knowledge, it is possible to advance into subject areas such as mounting and dismounting of rolling bearings using the optimum tools and the condition monitoring of bearing arrangements, especially through the use of noise, vibration and torque measurements.

Systematic learning processes, in conjunction with the appropriate methods, assist the training participant to discover the world of bearing arrangements. With the support of machine building engineers and technicians who have undergone didactic and methodological training, there is no longer any obstacle to effective learning progress.

Target groups Our training courses cover the information needs of employees in a very wide variety of areas of activity within a company. In this way, the technically oriented employee, whether a designer, fitter or maintenance person can find the right training course, in the same way as the employee in business administration, for example in purchasing.

Structure All target groups are considered using a uniform training approach. In general, the initial steps are provided by basic training covering the different characteristics, features and types of rolling bearings, plain bearings and linear guidance systems as well as their combination to form systems, extending all the way to mechatronic units. Application examples reflect the selection criteria and the customer benefits achieved.

These product-oriented training courses are followed by modules covering rolling bearing theory as well as selected applications. Rolling bearing theory conveys the necessary knowledge on subjects such as bearing clearance, load distribution in the bearing, rating life and lubrication.

In workshops, the participants concentrate on applications, for example the bearing arrangements in a machine tool or a shaft bearing arrangement. All process steps are covered, from bearing selection and bearing calculation through to mounting. We also offer workshops in the field of mechatronics.

Optionally, we offer training courses on condition-based maintenance in the field of vibration analysis. These courses include product training, as well as the certification of personnel to DIN ISO 18436-2.



Training

Several training modules cover the mounting and dismounting of rolling bearings and linear guidance systems. Based on perception and exercises, the participant gains the mounting knowledge and skills that he will require in practice. Our training courses on mounting cover a large number of applications. Mounting exercises on individual products are followed by work on more complex systems such as gearboxes or wheelsets.

The possibilities for plannable and economical design of maintenance work on machines, plant and rolling bearings are communicated to the training participant in appropriate courses. Our trainers communicate the theoretical principles of vibration analysis, the practical use of measurement systems and the handling of configuration and analysis software. The theoretical knowledge acquired is consolidated by means of practical exercises.

Training locations

Schaeffler has its own training centres worldwide. Qualified presenters with considerable experience ensure practice-oriented knowledge transfer in various languages at local sites. Alternatively, we will be pleased to train your employees at your location.

Training centres worldwide

The Schaeffler training centres (headquarters in Eltmann, Germany) offer theoretical and practical training courses in their modern training facilities. All product and services portfolios of Schaeffler Technologies are covered in detail. Starting from the principles and progressing to more detailed special knowledge, training courses communicate knowledge of rolling bearing theory, mounting and dismounting as well as all levels of condition monitoring and mechatronics.

Quality assurance

Through continuous market monitoring and exchange of experience, Schaeffler is in a position to continuously improve its training courses. What is particularly important to us is the ideas and suggestions that we receive through feedback from our training participants. Certification of the Schaeffler Technical Training Centres to ISO 9001:2008 underlines our continuous aspiration to increasing quality.

Training courses, standard and individual

The standard programme of training courses is sufficient in most cases to achieve acquisition of the knowledge necessary for day-to-day work. Upon customer request, Schaeffler also offers individually tailored training courses. In these cases, customers can themselves define the key components of the content. The standard training portfolio for the areas of rolling bearing technology and mounting as well as condition monitoring is already comprehensive; an excerpt is shown in the table.

Excerpt from the Schaeffler training portfolio

Training courses	
Rolling bearing technology and mounting	Basic training: Rolling bearing technology
	Mounting of rotary bearings
	Basic training: Mounting of rolling bearings (in gearboxes)
	Practical training: Mounting of rolling bearings (using large rolling bearings)
	Linear – Products and applications
	Mounting of linear bearings
	Rolling bearing failures: Identifying causes – Optimising operation
	Mounting and maintenance of rolling bearings for rail vehicle maintenance personnel (customer location)
	Maintenance of spindle bearings
Condition Monitoring	Detector III: introduction, advanced level, machine diagnosis, balancing
	SmartCheck: introduction, advanced level
	Vibration-based condition monitoring to ISO 18436-2 with certification
	DTECT X1s
	ProCheck
	Administrator 4
Mechatronics	Basic training: Mechatronics
	Follow-on training: Mechatronics
	Practical training: Mechatronics
Special training	Training completely oriented to the application



Training

Training material

Literature on the correct mounting of bearings is readily available, however there is a general lack of appropriate equipment on which apprentices can practise in as practical a sense as possible.

As a result, trainers from the Schaeffler training workshops have developed a mounting cabinet and a mounting cross for practising the mounting and dismounting of rolling bearings.

Mounting cabinet

The mounting cabinet is used in the basic course. The aim of this rolling bearing course is to communicate knowledge on the selection of the correct bearing, correct mounting and dismounting and the maintenance of bearing positions. Material from the mounting cabinet is, however, also used to provide instruction on individual contents with the aid of various mounting sets, *Figure 1*.



Figure 1
Basic course:
Mounting cabinet

Mounting cross

In order to provide professional training courses on the correct mounting and dismounting of rolling bearings, Schaeffler has developed the mounting cross, *Figure 2*. This piece of equipment allows the expert to communicate the correct handling procedure visually, using a variety of different bearings, and under realistic conditions.



Figure 2
Mounting cross

Further information on the Internet

- Comprehensive information can be found at www.schaeffler.de in the menu Products & Services ➔ INA/FAG Products ➔ Training
- Enquiries: schulungszentrum@schaeffler.com, +49 9522 71-503.



Ordering designation	Title
Mounting	
TPI 156	Tapered Roller Bearing Units TAROL – Mounting, Maintenance, Repair
TPI 180	FAG Tools for Thermal Dismounting
TPI 195	FAG Pressure Generation Devices
TPI 196	FAG Hydraulic Nuts
TPI 200	FAG Heating Devices for Mounting of Rolling Bearings
MH 1	Mounting of Rolling Bearings
WL 80 369	Services flyer: Heating of Bearings using Medium Frequency Technology
WL 80 376	FAG Medium Frequency Heating Device
Lubrication	
TPI 168	Arcanol Rolling Bearing Greases
TPI 176	Lubrication of Rolling Bearings
Training	
WL 80 386	Certified Vibration Expert DIN ISO 18436-2

Ordering designation	Title
Condition Monitoring	
TPI 170	FAG DTECT X1 _s – Continuous Monitoring of Plant and Machinery
TPI 182	FAG Alignment Tools – Top-Laser: SMARTY2 · TRUMMY2 · EQUILIGN · SHIM
TPI 199	FAG ProTorq
TPI 214	FAG SmartCheck
TPI 234	FAG GreaseCheck – Condition Monitoring of Greases in Rolling Bearings
TPI WL 80-64	FAG Detector III – The Solution for Monitoring and Balancing
TPI WL 80-69	FAG ProCheck – State of the Art Machinery Monitoring for Maximum Availability
WL 80 362	Flyer: FAG ProCheck
WL 80 363	Flyer: FAG ProCheck Ex
WL 80 365	Flyer: FAG ProTorq
WL 80 366	Flyer: FAG Wear Debris Check
WL 80 368	Services flyer: Thermography
WL 80 373	Flyer: FAG WiPro _s
WL 80 374	Services flyer: Endoscopy
WL 80 375	Flyer: FAG SmartCheck
WL 80 377	Flyer: FAG Temperature Measuring Devices
WL 80 378	Flyer: FAG Top-Laser EQUILIGN
WL 80 380	Flyer: FAG GreaseCheck
Rolling bearing reconditioning	
TPI 207	Reconditioning and Repair of Rolling Bearings
WL 80 367	Flyer: Maintenance Service of Wheelset Bearings
WL 80 383	Flyer: Mounting and Reconditioning Services



Addresses

Germany Schaeffler Technologies AG & Co. KG
Postfach 1260
97419 Schweinfurt
Georg-Schäfer-Straße 30
97421 Schweinfurt
Tel. +49 2407 9149-66
Fax +49 2407 9149-59
industrial-services@schaeffler.com
www.schaeffler.com/services

Schaeffler Technologies AG & Co. KG
Industriestraße 1–3
91074 Herzogenaurach
Tel. +49 91 32 82-0
Fax +49 91 32 82-49 50
info.de@schaeffler.com

Schaeffler Technologies AG & Co. KG
Industriestraße 2
97483 Eltmann
Tel. +49 9522 71-503
Fax +49 9522 71-511
schulungszentrum@schaeffler.com

Worldwide You can find all the addresses and contacts for Schaeffler at www.schaeffler.com

Schaeffler Technologies AG & Co. KG

Postfach 1260

97419 Schweinfurt

Georg-Schäfer-Straße 30

97421 Schweinfurt

Germany

Internet www.schaeffler.com/services

E-mail industrial-services@schaeffler.com

Phone +49 2407 9149-66

Fax +49 2407 9149-59

